

Winter 1998

Synthesis of vicinal bisamidines and bisaminals for the preparation of tetraazamacrocycles and the synthesis of cross-bridged cyclam derivatives and studies on their complexation of small cations

David Philip Reed

University of New Hampshire, Durham

Follow this and additional works at: <https://scholars.unh.edu/dissertation>

Recommended Citation

Reed, David Philip, "Synthesis of vicinal bisamidines and bisaminals for the preparation of tetraazamacrocycles and the synthesis of cross-bridged cyclam derivatives and studies on their complexation of small cations" (1998). *Doctoral Dissertations*. 2057.
<https://scholars.unh.edu/dissertation/2057>

This Dissertation is brought to you for free and open access by the Student Scholarship at University of New Hampshire Scholars' Repository. It has been accepted for inclusion in Doctoral Dissertations by an authorized administrator of University of New Hampshire Scholars' Repository. For more information, please contact nicole.hentz@unh.edu.

INFORMATION TO USERS

This manuscript has been reproduced from the microfilm master. UMI films the text directly from the original or copy submitted. Thus, some thesis and dissertation copies are in typewriter face, while others may be from any type of computer printer.

The quality of this reproduction is dependent upon the quality of the copy submitted. Broken or indistinct print, colored or poor quality illustrations and photographs, print bleedthrough, substandard margins, and improper alignment can adversely affect reproduction.

In the unlikely event that the author did not send UMI a complete manuscript and there are missing pages, these will be noted. Also, if unauthorized copyright material had to be removed, a note will indicate the deletion.

Oversize materials (e.g., maps, drawings, charts) are reproduced by sectioning the original, beginning at the upper left-hand corner and continuing from left to right in equal sections with small overlaps. Each original is also photographed in one exposure and is included in reduced form at the back of the book.

Photographs included in the original manuscript have been reproduced xerographically in this copy. Higher quality 6" x 9" black and white photographic prints are available for any photographs or illustrations appearing in this copy for an additional charge. Contact UMI directly to order.

UMI

A Bell & Howell Information Company
300 North Zeeb Road, Ann Arbor MI 48106-1346 USA
313/761-4700 800/521-0600

**SYNTHESIS OF VICINAL BISAMIDINES AND BISAMINALS
FOR THE PREPARATION OF TETRAAZAMACROCYCLES**

AND

**THE SYNTHESIS OF CROSS-BRIDGED CYCLAM DERIVATIVES
AND STUDIES ON THEIR COMPLEXATION OF SMALL CATIONS**

BY

**David P. Reed
B.S., Saint Michael's College, 1993**

DISSERTATION

**Submitted to the University of New Hampshire
in Partial Fulfillment of
the Requirements for the Degree of**

Doctor of Philosophy

in

Chemistry

December, 1998

UMI Number: 9923837

UMI Microform 9923837
Copyright 1999, by UMI Company. All rights reserved.

**This microform edition is protected against unauthorized
copying under Title 17, United States Code.**

UMI
300 North Zeeb Road
Ann Arbor, MI 48103

This dissertation has been examined and approved.

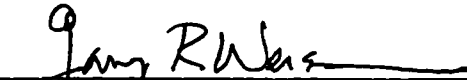

Dissertation Director,
Gary R. Weisman,
Professor of Chemistry

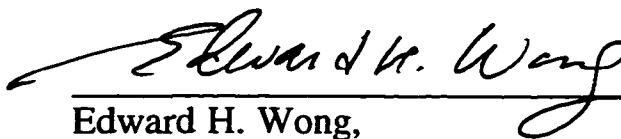

Edward H. Wong,
Professor of Chemistry

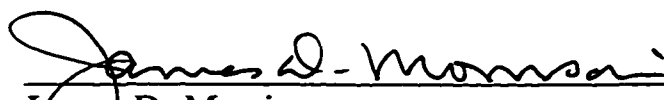

James D. Morrison,
Professor of Chemistry

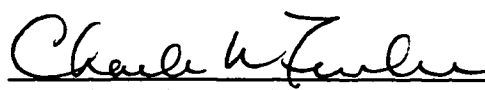

Charles K. Zercher,
Associate Professor of Chemistry

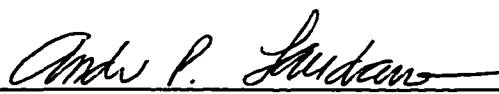

Andrew P. Laudano,
Associate Professor of Biochemistry

November 2, 1998.
Date

DEDICATION

It would not have been possible to complete this dissertation without the love and support of my wife, Coreen, who I love very much.

ACKNOWLEDGMENTS

There were many people who have contributed to my life in the past few years at UNH. I would like to thank them all. Your support and friendship has made UNH a wonderful place to learn and live for the past five years.

The members of the Weisman group, past and present, have created a enjoyable and challenging environment. I particularly thank Dan Hill and Craig West for their patience and guidance. I owe a great deal to the both of them for helping me develop the lab skills I have acquired. I personally thank Craig for the fine example he set for me. In my mind he is and always will be a role model, and a good friend. Mike Hines has also been an invaluable friend and colleague in the past 4 years. I will always remember the time we worked together in the lab as some of the best of my life.

I am extremely proud to say that I earned my Ph. D. under the guidance of Gary R. Weisman. I know that everything he has done in the last five years was done with my best interest at heart and I could never thank him enough for what he has done form me, professionally and personally. I was very fortunate to have two advisors. Ed Wong provided me with unending support whenever I needed it. I am appreciative for his guidance and patience, particularly while Gary was on sabbatical.

I must also thank the members of the faculty of the Chemistry Department and the University Instrumentation Center. Without the patience of Kathy Gallagher, I could not

have completed the experiments in this dissertation.

Finally, this work has been financially supported by Dupont-Merck and the National Institutes of Health. This support has provided me with two research assistantships. I am also very grateful to the UNH Chemistry Department for financial support during my time here.

TABLE OF CONTENTS

DEDICATION.....	iii
ACKNOWLEDGEMENTS.....	iv
TABLE OF CONTENTS.....	vi
LIST OF FIGURES.....	x
LIST OF SCHEMES.....	xi
LIST OF TABLES.....	xvi
ABSTRACT.....	xviii

CHAPTER I - STUDIES OF VICINAL BISAMIDINES AND BISAMINALS AND THEIR UTILITY AS PRECURSORS FOR MACROCYCLIC TETRAAMINES

I. INTRODUCTION.....	1
II. BACKGROUND.....	3
Preparative Methods for Tetraazacycloalkanes.....	3
Regioselective Reduction of Aminals and Amidines.....	9
Preparative Methods for Bisaminals and Bisamidines.....	12
III. RESULTS AND DISCUSSION.....	16
Synthesis of Cyclen (2).....	16

Synthesis of 1,4,7,10-Tetraazacyclotridecane (19).....	25
Synthesis of Cyclam (1).....	26
Synthesis of Benzocyclam (34).....	30
Attempted Synthesis of 35 and 36.....	34
Investigation of Reagents for Bisamidine Formation	
Other Than Dithiooxamide.....	35
Attempted Preparation of Dibenzotetraaza Macrocycles.....	38
Attempted Bisamidine Preparation from 11.....	40
Hydrolysis of Bisaminals.....	42
Attempted Transamidation Reaction of 51.....	46
Protonation of 16.....	50
Preparation of Derivatives of 16.....	50
Attempted Diels-Alder Chemistry with 16.....	55

CHAPTER II - SYNTHESIS OF CROSS-BRIDGED CYCLAM DERIVATIVES

I. INTRODUCTION.....	57
II. BACKGROUND.....	60
Preparation of 83 and 92.....	60
III. RESULTS AND DISCUSSION.....	65
Synthesis of Amide Armed Cross-Bridged Cyclam Derivatives.....	65
Attempted Synthesis of Hexaaza Cross-Bridged Cyclam Derivatives.....	67

Reaction of 85 with 108 and 109	70
Attempted Preparation of 115	73
Reaction of 92 with 109	75
Cross-Bridged Cyclam Derivatives with Decreased Basicity.....	76
Preparation of Aryl Armed Cross-Bridged Cyclam Derivatives.....	78
Preparation of 125	83
Reaction of Methyl Iodide and Benzyl Bromide with 125	93

CHAPTER III - STUDIES OF THE COMPLEXATION OF SMALL CATIONS BY
CROSS-BRIDGED CYCLAM DERIVATIVES

I. INTRODUCTION.....	97
II. BACKGROUND.....	99
III. RESULTS AND DISCUSSION.....	104
General Method for the Calculation of K_{rel}	104
Complexation of $LiClO_4$ and $NaClO_4$ by 95	106
Competition of $LiClO_4$ vs. $NaClO_4$ for 95	107
Competition of 95 vs. 83 for $LiClO_4$	110
Complexation of $LiClO_4$ and $NaClO_4$ by 137	113
Competition of $LiClO_4$ vs. $NaClO_4$ for 137	114
Competition of 137 vs. 83 for $LiClO_4$	116
Complexation of H^+ , $LiClO_4$ and $NaClO_4$ by 92	120

Competition of 92 vs. 83 for LiClO ₄	123
Competition of 92 vs. 88 for LiClO ₄	126
Complexation of LiClO ₄ and NaClO ₄ by 114	130
Competition of LiClO ₄ vs. NaClO ₄ for 114	131
Competition of 114 vs. 83 for LiClO ₄	134
Competition of 95 vs. 137 for LiClO ₄	134
Determination of Thermodynamic Mixtures Over Kinetic Mixtures in competition Experiments.....	135
Complexation of Cu ²⁺ by Cross-Bridged Cyclam Derivatives.....	137
CHAPTER IV - EXPERIMENTAL SECTION	
I. GENERAL METHODS.....	139
II. SOLVENTS.....	140
III. REAGENTS.....	142
IV. SYNTHESES.....	146
V. VARIABLE TEMPERATURE NMR EXPERIMENTS.....	211
APPENDICES.....	212
I. ORGANIC SYNTHESES SUBMISSION.....	213
II. SPECTRAL APPENDIX.....	226
III. COMPOUND INDEX.....	360
LIST OF REFERENCES.....	366

LIST OF FIGURES

<u>Figure</u>	<u>Page</u>
1.1 Cyclization Using “Endo-Templating” and “Exo-Templating”.....	12
1.2 ¹ H NMR Spectra for 16 and 50	44
1.3 Endo-Templated “Zip Reaction”.....	47
2.1 ¹³ C NMR Spectra of 123 at 25 °C.....	85
2.2 Simulated Spectra for the Enantiomerization of 125	88
2.3 Enantiomerization of 125	92
2.4 Molecular Model of 125 and 85 (MM2).....	93
3.1 ¹ H NMR Spectra for the Competition of 137 vs. 83 for LiClO ₄ in CD ₃ CN.....	118
4.1 Eyring Plot for 125	213

LIST OF SCHEMES

<u>Number</u>		<u>Page</u>
1.1	Van Alphen's Synthesis of Cyclam (1).....	3
1.2	Stetter and Maeyer's Synthesis of Cyclam (1).....	4
1.3	Richman-Atkins Synthesis of Cyclen (2).....	6
1.4	Barefield's Synthesis of Cyclam (1).....	8
1.5	Mechanism for the Regioselective Reduction of Amidines and Aminals.....	9
1.6	Examples of Regioselective Reductions of Cyclic Bisaminals and Bisamidines to Diamines.....	10
1.7	Retrosynthetic Approach to the Synthesis of Tetraaza- Macrocycles Using Regioselective Reduction Methodology.....	11
1.8	Synthesis of 11 from Ethylenediamine and Dithiooxamide.....	13
1.9	Synthesis of 11 from Ethylenediamine and Li ^o Metal.....	14
1.10	Synthesis of 11 from Ethylenediamine and Cyanogen via 12	15
1.11	Reported Results for the Reaction of Triethylenetetraamine and Glyoxal.....	16
1.12	Experimental Results for the Reaction of Triethylenetetraamine and Glyoxal....	17
1.13	Proposed Products (11 , 15) for the Reaction of Ethylenediamine and Dithiooxamine.....	17
1.14	Preparation of 16	18
1.15	Preparation of Cyclen (2) by Regioselective Reduction of 16	22

1.16	Hervé's New Synthesis of 1 , 2 , and 19	24
1.17	Preparation of [13]aneN ₄ (19) by Regioselective Reduction of 18	25
1.18	Preparation of <i>cis/trans</i> - 21 from 20	26
1.19	Reduction of <i>cis/trans</i> - 21 with DIBALH.....	27
1.20	Preparation of 23	27
1.21	Hydrolysis of 23	28
1.22	Reduction of 23 with DIBALH and LiAlH ₄	29
1.23	Proposed Reduction Mechanism for the Reduction of 23 to <i>trans</i> - 21 and <i>cis</i> - 21 to Cyclen (2).....	30
1.24	Proposed Reduction of 28	31
1.25	Preparation of 31 from 32	32
1.26	Attempted Preparation of 28 from 31	33
1.27	Preparation of <i>cis/trans</i> - 33 from 31	33
1.28	Preparation of Benzocyclam (34).....	33
1.29	Attempted Preparation of 35	34
1.30	Attempted Preparation of 36	35
1.31	Kantlehner's Alkylation of 38 with (CH ₃) ₃ OBF ₄	37
1.32	Proposed Bisamidine Synthesis Using 42	37
1.33	Preparation of 44 and Attempted Preparation of 16 from 44	38
1.34	Preparation of 45 and 46	39
1.35	Attempted Reduction of 46 and 47	40

1.36	Proposed Approach to the Synthesis of Carbon-Functionalized Tetraaza Macrocycles.....	41
1.37	Attempted Cyclization Reactions Using 11	42
1.38	Hydrolysis of 16	43
1.39	Hydrolysis of 18 and 23	45
1.40	Azeotropic Dehydration to Afford 16 and 23	45
1.41	Proposed Hydrolysis of 23 to 55 as an Alternative Synthesis to Cyclam (1).....	46
1.42	Proposed Transamidation Reaction of 50 to 51	47
1.43	Example of the “Zip Reaction”.....	48
1.44	Mechanism of the Transamidation of 50 to 51	49
1.45	Attempted Transamidation of 50 to 51	49
1.46	Preparation of 60 from 16 with Benzyl Bromide.....	51
1.47	Reduction of 60 with DIBALH.....	52
1.48	Hydrolysis of 60	52
1.49	Mechanistic Aspects of the Reduction of 60 and 69	53
1.50	Reaction of 16 with <i>p</i> -Toluenesulfonylchloride.....	54
1.51	Cyclization of 16 to 75	55
1.52	Attempted Diels-Alder Reaction with 16 as the Diene.....	56
2.1	Wainwright’s Synthesis of Adjacent-Bridged Cyclam Derivatives.....	58
2.2	Weisman and Wong’s Dimethyl Cross-Bridged Cyclam.....	58

2.3	Campolini's Synthesis of Dimethyl Cross-Bridged Cyclen.....	59
2.4	Synthesis of Dimethyl Cross-Bridged Cyclam (83) from Cyclam (1).....	60
2.5	Enantiomerization of 85.....	61
2.6	Regioselective Alkylation of 85 with Methyl Iodide.....	61
2.7	Reduction of 86 with NaBD ₄	62
2.8	Preparation of 92 from 85.....	64
2.9	Synthesis of 93 and 94.....	65
2.10	Preparation of 95 and 96 from 92.....	66
2.11	Hill's Synthesis of 97 from 92.....	66
2.12	Preparation of 98.....	67
2.13	Attempted Reduction of 96 with BH ₃ •THF.....	68
2.14	Reduction of 97 as Reported by Hill.....	68
2.15	Attempted Reduction of 97 with BH ₃ •THF.....	68
2.16	Proposed reduction of 97 with AlCl ₃ /NaBH ₄ in THF.....	69
2.17	Synthesis of 105.....	69
2.18	Preparation of N-Tosylaziridine (104).....	70
2.19	Preparation of 107 from 92 and 104.....	70
2.20	Synthetic Method for the Preparation of Cross-Bridged Cyclam Derivatives.....	71
2.21	Synthesis of 114 Reported by Hill.....	73
2.22	Attempted Preparation of 115.....	74

2.23	Preparation of 116	75
2.24	Protonation of 83 , 83•H⁺ and 83•2H⁺	76
2.25	Preparation of 118	79
2.26	Preparation of 119	79
2.27	Attempted Preparation of 122	81
2.28	Mechanism of Nucleophilic Aromatic Substitution through a Benzyne Intermediate.....	81
2.29	Examples of Nucleophilic Aromatic Substitution Using N-Lithioamide Nucleophiles.....	82
2.30	Attempted Arylation of 92 with Bromobenzene.....	83
2.31	Preparation of 125 from Benzocyclam (34).....	83
2.32	Regioselective Methylation of 125	94
2.33	Proposed Reduction of 126	95
2.34	Benylation of 125	95
2.35	Proposed Reduction of 130	95
2.36	Proposed Targets Available from 131	96

LIST OF TABLES

<u>Table</u>	<u>Page</u>
1.1 Yields for the Cyclization Step for the Richman-Atkins Method.....	7
1.2 Reaction of Dithiooxamide and Bromoethane. Reaction Conditions and NMR Data.....	21
1.3 NMR Data for the Protonation of 16 with TFA.....	44
2.1 Reaction Conditions and Results for the Reaction of 85 with 108 and 109	72
2.2 ¹³ C NMR Chemical Shifts for 125 at Various Probe Temperatures.....	86
2.3 Results of DNMR Simulations of 125	90
3.1 ¹³ C NMR Chemical Shifts for Complexation Experiments on 95 in CD ₃ CN.....	109
3.2 ¹³ C NMR Chemical Shifts for the Competition of 95 vs. 83 for LiClO ₄ in CD ₃ CN.....	112
3.3 Results of LiClO ₄ vs. NaClO ₄ for 137 in CD ₃ CN.....	115
3.4 ¹³ C NMR Chemical Shifts for the Competition of 83 vs. 92 for LiClO ₄ in CD ₃ CN.....	124
3.5 Results of the Competition of 83 vs. 92 for LiClO ₄ in CD ₃ CN.....	125
3.6 ¹³ C NMR Chemical Shifts for the Competition 88 vs. 92 for LiClO ₄ in CD ₃ CN.....	127
3.7 Results of the Competition 88 vs. 92 for LiClO ₄ in CD ₃ CN.....	128

3.8	¹³C NMR Chemical Shifts for the Complexation of 114 with LiClO₄ and NaClO₄.....	133
4.1	Data Used for the DNMR Simulation of 125.....	214

ABSTRACT

SYNTHESIS OF VICINAL BISAMIDINES AND BISAMINALS FOR THE PREPARATION OF TETRAAZAMACROCYCLES

AND

THE SYNTHESIS OF CROSS-BRIDGED CYCLAM DERIVATIVES AND STUDIES ON THEIR COMPLEXATION OF SMALL CATIONS

by

David P. Reed

University of New Hampshire, December, 1998

A new methodology for the preparation of tetraazamacrocycles is presented. This new methodology utilizes a regioselective reduction of vicinal bisaminals (**33**) and bisamidines (**16**) precursors to afford ring expanded tetraamines. This chemistry has provided a synthetic route for the preparation of benzocyclam (**34**), a compound whose preparation is unreported in the literature.

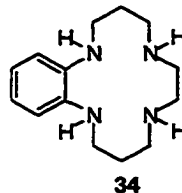
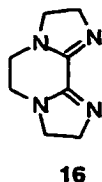
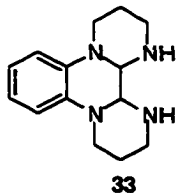

This methodology has aided in the preparation of cross-bridged cyclam derivatives (**83**, **92**, **95**). Cross-bridged cyclam derivatives are bicyclic tetraamines which adopt low energy conformations appropriate for the complexation of small cations. Cross-bridged cyclam derivatives have potential utility in clinical and nuclear medicine as well as bioinorganic chemistry. The preparation of new derivatives of cross-bridged cyclam and studies on their chemistry are presented.

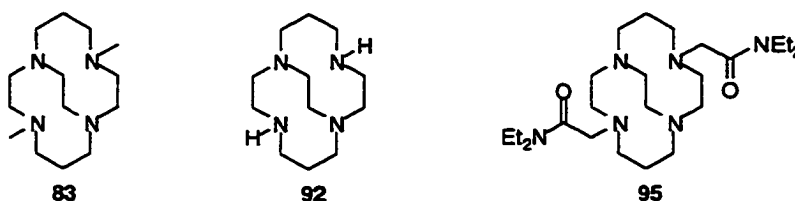

Cross-bridged cyclam derivatives are good complexers of Li^+ . In fact, cross-bridged cyclam derivatives complex Li^+ selectively over Na^+ . Ligands which can selectively bind Li^+ in the presence of Na^+ would have significant utility as Li^+ sensors which could monitor small concentrations of Li^+ in the presence of abundant Na^+ . Experiments on the relative selectivity for cross-bridged cyclam ligands for Li^+ and Na^+ as well as the relative complexation ability between ligands is presented.

CHAPTER I

STUDIES OF VICINAL BISAMIDINES AND BISAMINALS AND THEIR UTILITY AS PRECURSORS FOR MACROCYCLIC TETRAAMINES

I. INTRODUCTION

Cyclic compounds having multiple amino moieties linked by methylene carbon units of various length are classified as polyazacycloalkanes. Many polyazacycloalkanes have been reported and are important in the fields of organic and organometallic chemistry. As nitrogen analogues of crown ethers, polyazacycloalkanes are useful as ligands, particularly for transition metal cations.^{1,2} The replacement of N for O does significantly alter the properties of polyazacycloalkanes with respect to polyether analogues. The decreased electronegativity of nitrogen with respect to oxygen in addition to the difference in the basicity give rise to many of the observed differences in the complexation of various metal cations.³ While both atoms are considered to be “hard” in saturated compounds, polyaza analogues are often found to complex metal ions better than the respective polyethers. Another advantage of polyazacycloalkanes over polyethers in the rational design of ligands is the ability to functionalize nitrogen atoms of the parent cyclic backbone.⁴⁻⁸ The attachment of pendant arms or the formation of bridged polydentate derivatives allows for a variety of ligands to be prepared from one polyazacycloalkane.⁹

The synthesis of a variety of derivatives of polyazacycloalkanes¹⁰⁻¹² has led to many biomedical applications for these ligands.

Clinical applications¹³ for polyazacycloalkane derivatives have been developed as well as applications in the fields of bioinorganic chemistry¹⁴ and nuclear medicine.¹⁵ Some examples of these applications include (1) the use of transition metals such as Fe^{3+} , Gd^{3+} and Mn^{2+} with a ligand as contrast agents in MRI imaging,¹⁶ (2) attachment of antibodies to the polyazacycloalkane structure for various studies,¹⁷ (3) anti-HIV activity has been shown for some compounds having two polyazacycloalkanes linked together through nitrogen atoms.^{18,19} Research in these areas is still extremely active and new applications for these compounds are published frequently.

This chapter will discuss a subset of polyazacycloalkanes which possesses four secondary amino nitrogen atoms. Tetraazacycloalkanes have been well studied and syntheses for their preparation are reported in the chemical literature.^{10-12,20-23} These synthetic methods rely heavily on protecting groups and some require high dilution conditions to facilitate ring closure. These two aspects of a synthetic method are undesirable in modern synthetic design strategy at a time when environmental consequences of chemical reactions are seriously scrutinized. Commercial chemical suppliers also offer some tetraazacycloalkanes but at significantly higher cost.

A new methodology for the preparation of tetraazacycloalkanes which is inexpensive and environmentally favorable is highly desirable. This chapter introduces a new synthetic methodology which avoids the use of protecting groups and high dilution

conditions. This new synthetic strategy is highly “atom economic,” incorporating all of the atoms built into the starting material into the product, reducing the waste stream of the process.²⁴ In the following background section the other methods available for the preparation of tetraazacycloalkanes are reviewed to further establish the rationale for the chemistry reported in this chapter.

II. BACKGROUND

Preparative Methods for Tetraazacycloalkanes

The first preparation of a tetraazacycloalkane was reported over 60 years ago when Van Alphen described what he believed to be cyclam (1) (1,4,8,11-tetraazacyclotetradecane).²⁵ The reaction of ethylenediamine and 1,3-dibromopropane afforded a linear tetraamine which was proposed to have cyclized to 1

Scheme 1.1

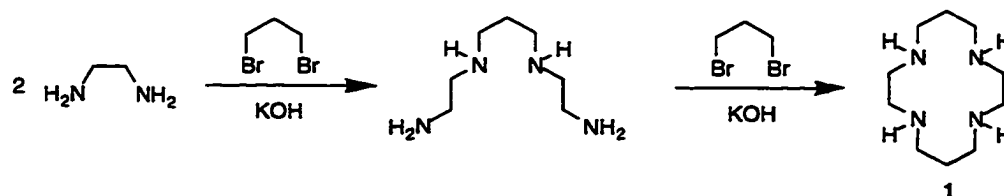

of the preparation of cyclam, the use of protecting groups makes the procedure much longer synthetically and, in conjunction with the high dilution conditions, generates a significant waste stream.

Bosnich later published a modification of Van Alphen's original synthesis. He claimed that the Stetter and Mayer approach, which was synthetically more elegant, was not practical.²⁷ But the yield of cyclam reported by Bosnich was very poor (~5%) making other synthetic approaches desirable.

In 1974 Richman and Atkins published a general route for the preparation of medium-ring and macrocyclic polyheteroatom compounds.^{28,29} This approach utilized nitrogen protecting groups and medium dilution conditions to perform the ring closure (Scheme 1.3). Stetter and Roos had described the utility of tosyl protecting groups for nitrogen atoms in the synthesis of macrocyclic tetraamines in 1954.³⁰ The use of tosyl protecting groups for nitrogen, tosylate leaving groups instead of halides and DMF as the solvent were found to be the optimal reaction conditions for the Richman-Atkins method. Furthermore, this method afforded yields for tetraazacycloalkanes which were much improved with respect to the previous approaches. The obvious advantage of this approach is the convergent nature of the synthesis. Scheme 1.3 shows the synthesis of cyclen (2) (1,4,7,10-tetraazacyclododecane) using this approach. Variation of **A** and **B** allows for the preparation of a variety of macrocycles of different ring sizes with various numbers of heteroatoms. Furthermore, tosylation of amines and alcohols is typically a simple transformation affording solids which can be easily purified by recrystallization.

Scheme 1.3

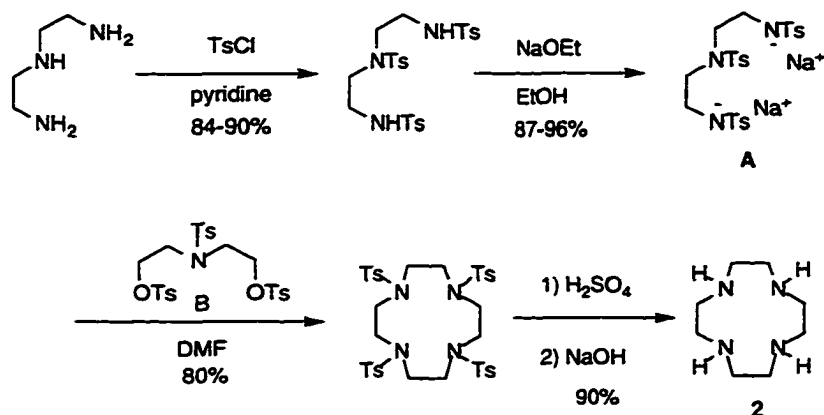
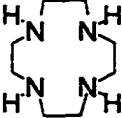
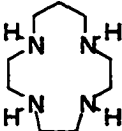
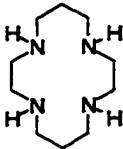
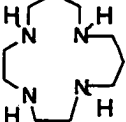
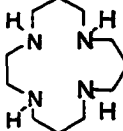
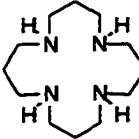

Table 1.1 lists yields for the cyclization step of the Richman-Atkins method for some tetraazacycloalkanes.²⁹ This cyclization reaction, however, has also been shown to be sensitive to small changes in the reaction conditions. A survey of different macrocycles prepared by this general method showed drastic variation in yields. For example, reports from Atkins et al.²⁹ and Rasshofer and Vögtle³¹ have yields which varied up to 50% for the same macrocycle. Careful drying techniques for the DMF must be employed because water has been cited as the major contaminant in these reactions leading to decreased yields. Other factors such as the purity of the starting materials, the reaction temperature and time can cause significant yield variation. Modifications have been reported which have improved the methodology. For example, the use of K₂CO₃ or Cs₂CO₃ as the base *in situ* combines the deprotonation and cyclization steps. This modification shortens the procedure by one step and was shown to afford improved yields.³²⁻³⁴ Lower reaction temperatures and longer reaction times have also shown increased yields.³³ Even with

Table 1.1**Yields for the Cyclization Step for the Richman-Atkins Method
(Detosylation not included in reported yield)**

1,4,7,10- Tetraazacyclododecane (Cyclen) 	1,4,7,10- Tetraazacyclotridecane 	1,4,8,11- Tetraazacyclotetradecane (Cyclam) 
80%	77%	70%
1,4,7,11- Tetraazacyclotetradecane (Isocyclam) 	1,4,8,12- Tetraazacyclopentadecane 	1,4,8,12- Tetraazacyclohexadecane 
80%	58%	90%

these caveats, the Richman-Atkins approach has become the method of choice for the preparation of many tetraazacycloalkanes.

Another approach was published in 1972 which is not as versatile Richman-Atkins method. Barefield utilized a transition metal template in the preparation of cyclam starting from a linear tetraamine and aqueous glyoxal.^{35,36} The transition metal, in this case Ni^{2+} , is used to coordinate to the 4 four amino nitrogen atoms. This effectively preorganizes the 12-atom tetraamine chain so that the two primary amino groups are positioned to facilitate ring closure. The glyoxal condensation gives an α -diimine which can be mildly reduced

with NaBH_4 . Following demetallation, the tetraazacycloalkane is obtained (Scheme 1.4).

This methodology has also allowed for the preparation of

1,4,8,12-tetraazacyclopentadecane from 1,4,8,12-tetraazatridecane (45-48%)³⁷. While this methodology did give better yields of cyclam (**1**) than other methods published at that time, there are some significant drawbacks. This methodology does not work for the preparation of cyclen (**2**). Furthermore, the use of perchlorate salts and the generation of cyanide waste makes this route less attractive.

Scheme 1.4

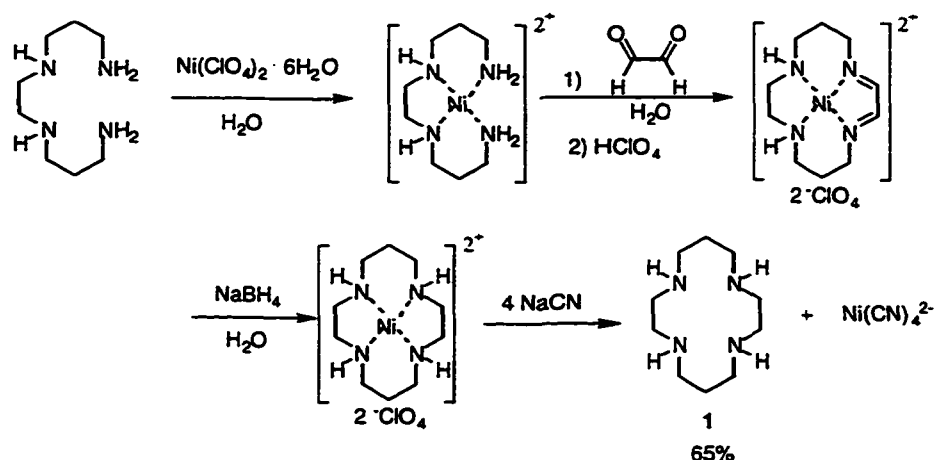

Comparison of all of the published methods for the preparation of tetraazacycloalkanes leads to the conclusion that new chemistry for their preparation would be highly desirable. The variability in the yields and the laborious procedures are inconvenient but can be accommodated. However, the environmentally unfriendly byproducts pose a greater concern, in their very nature and quantity, that cannot be ignored.

Regioselective Reduction of Aminals and Amidines

A possible alternative method based on the work of Yamamoto and Maruoka³⁸ was proposed independently by Gary R. Weisman and Roger W. Alder.³⁹ Yamamoto and Maruoka showed that aminal or amidine moieties could be reduced in a regioselective manner upon treatment with diisobutylaluminum hydride (DIBALH).

Yamamoto maintains that the regioselective reduction takes place directly through C-N σ bond cleavage by DIBALH. Alternatively, a mechanism involving iminium ion intermediates can be proposed. These two ideas are shown in Scheme 1.5. An aminal **3** with the general structure shown is deprotonated upon introduction of DIBALH solution to **4**. Yamamoto proposes, that in the presence of excess DIBALH, the tertiary amine is also

Scheme 1.5

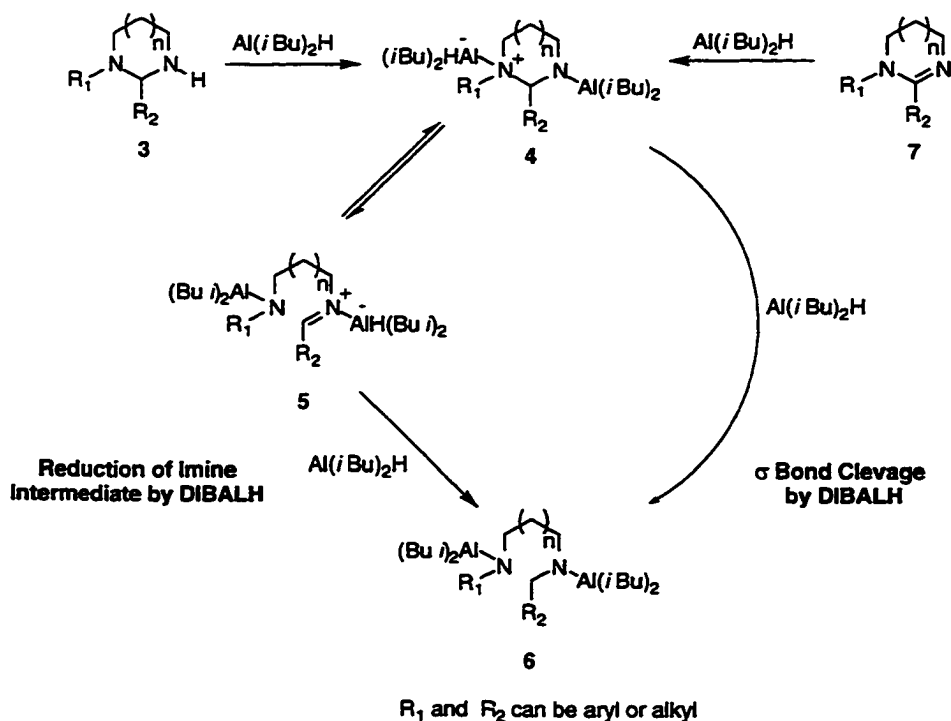

coordinated to an aluminum atom of DIBALH. If this is correct, the equilibrium shown between **4** and **5** could also be facilitated. Imine **5** would then be reduced by DIBALH resulting in species **6**. Upon aqueous workup, **6** affords the desired ring opened product. Direct C-N σ bond reductive cleavage of **4** would also lead to **6** as Yamamoto states in his paper. While it is unknown which mechanism is operative, ring opening is “unidirectional” and preferentially gives a single isomeric product. Amidine moieties also undergo this chemistry to give the same product from the analogous ring system. For example, amidine **7** would react with DIBALH to reduce the amidine moiety affording **4**, which as previously described, yields only one ring opened product. Furthermore, this reduction proceeded in good to excellent yield in almost all cases reported by Yamamoto.

Alder and coworkers^{40,41} and Alder, Weisman and coworkers⁴² have also utilized this chemistry in the preparation of large cyclic diamines. Fused bicyclic ring systems which contained aminal or amidine moieties in the ring fusion were prepared by known methods or purchased commercially. Reduction with DIBALH resulted in regioselective ring opening as predicted. Some examples of this chemistry are shown in Scheme 1.6.

Scheme 1.6

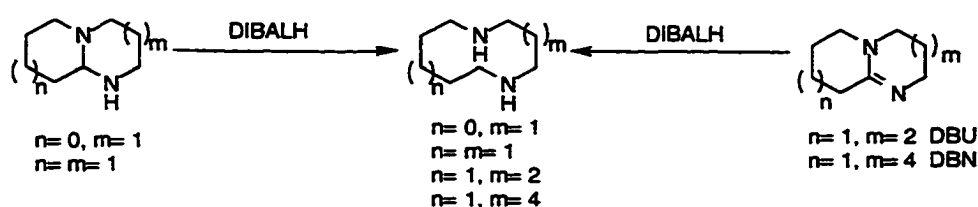

Application of this reductive ring expansion methodology to the synthesis of macrocyclic tetraamines would require that the amina or amidine moieties be incorporated into the ring fusion of a tricyclic precursor. Scheme 1.7 illustrates this idea in retrosynthetic form. The two carbon unit inserted in the cyclization step functions as an endo-template.⁴³ Unlike an exo or external template (Figure 1.1c), an endo template is not removed following the ring closure reaction. This concept is illustrated in Figure 1.1. There are two types of endo-templates which operate by forming smaller rings which are later expanded. The first type of templating operates by insertion of a side chain into a smaller ring (Figure 1.1a). This type will be discussed later in this chapter. The second type of templating involves cleaving a bond of a bicyclic ring system to afford a larger monocyclic ring (Figure 1.1b). The regioselective reduction with DIBALH of a vicinal bisaminal such as **8** or bisamidine **9** should perform this operation twice resulting in the expected doubly ring expanded target shown in Scheme 1.7. The endo-template becomes

Scheme 1.7

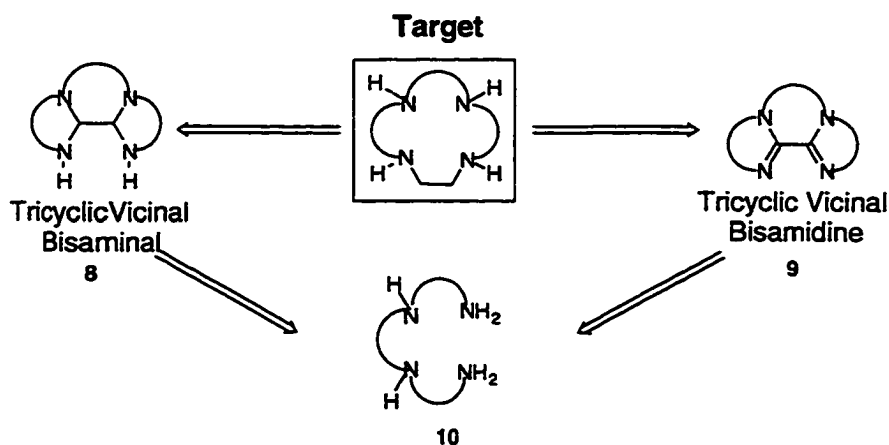
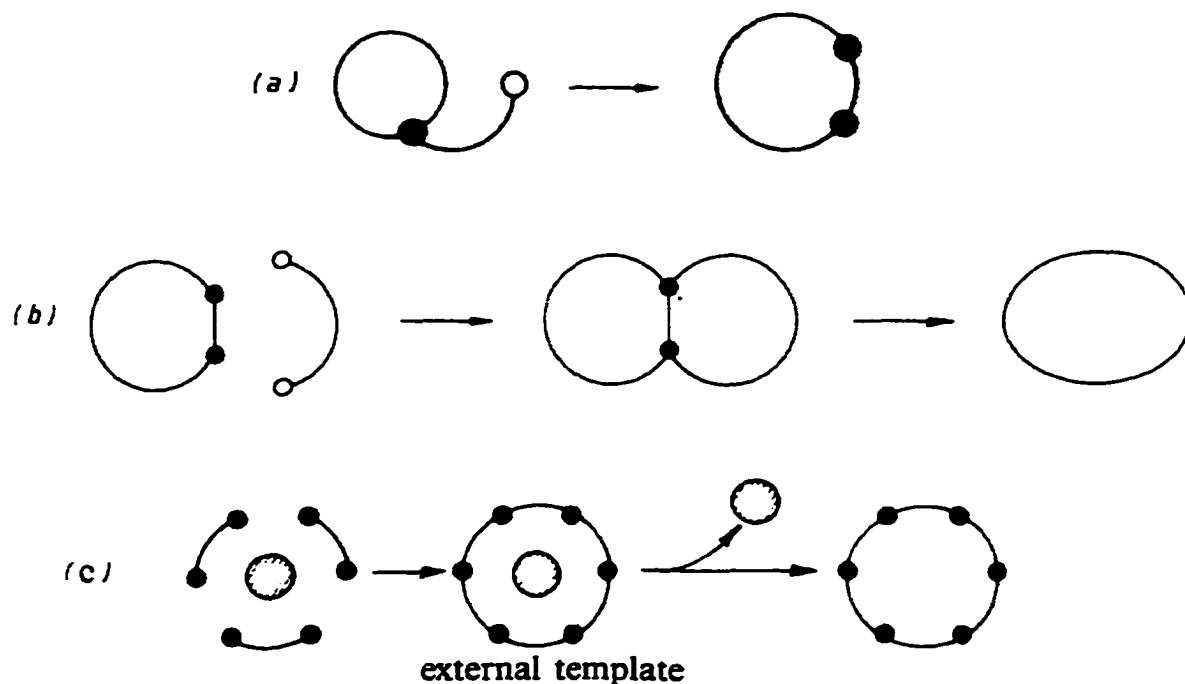

Figure 1.1⁴³: Cyclization Using “Endo-Templating” and “Exo-Templating”



incorporated into the macrocyclic structure by means of this potentially highly regioselective ring expansion reaction. This idea avoids difficult macrocyclic ring closure reactions by closing normal-sized rings and the macrocyclic tetraamine is formed in a highly atom economic manner. Therefore, to investigate this chemistry, linear tetraamine **10** must be cyclized in some manner to give the respective vicinal bisaminal or bisamidine.

Preparative Methods for Bisaminals and Bisamidines

The formation of aminals is usually effected by the reaction of a diamine to an aldehyde or a ketone.⁴⁴ The condensation of glyoxal with acyclic tetraamines of various chain length has been reported in the literature to be a simple way to prepare tricyclic bisaminals.⁴⁵⁻⁴⁸

The preparation of cyclic vicinal bisamidines suitable for reduction to tetraazacycloalkanes has not been reported in the literature.^{49,50} However, there have been some reports on vicinal bisamidines of oxalic acid. In 1898 Forssell reported that the reaction of ethylenediamine with dithioamide produced 2,2'-biimidazoline (**11**), a bicyclic vicinal bisamidine.⁵¹ The synthesis of **11** is shown in Scheme 1.8. This result was later confirmed by Lehr and Erlenmeyer in 1944.⁵² Wang and Bauman later modified this procedure by introducing bromoethane to dithioamide prior to the addition of the diamine.⁵³ The S-alkylation of thioamides has been well documented to result in improved reactivity of the thioamide carbon towards nucleophilic attack.⁵⁴ Under these modified conditions, Wang and Bauman prepared 2,2'-biimidazoline in 77% yield.

Reggel et al. also reported the preparation of **11**.⁵⁵ N-Lithioethylenediamine was reported to catalyze the reaction of ethylenediamine to afford **11**, hydrogen and ammonia in a variety of aromatic hydrocarbons. N-Sodioethylenediamine was also reported to provide **11** in addition to other unidentified products. The identity of the aromatic hydrocarbon

Scheme 1.8

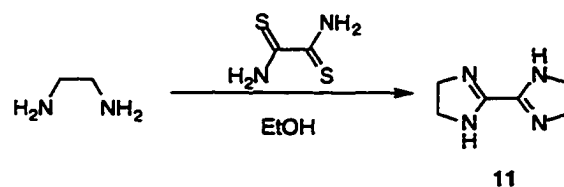

was reported to be significant and the best results were found when tetralin was used. Similar results were reported when toluene, ethylbenzene, isopropylbenzene and stilbene (*cis* and *trans*) were substituted for tetralin. There were few conclusions drawn by the authors to explain these results. Wotiz et al. also report that **11** was among the many products that were formed when ethylenediamine was treated with a strong base or alkali metal in the absence of an aromatic hydrocarbon.⁵⁶ Wotiz proposes that N-lithioethylenediamine can undergo a β hydride elimination to form a metal hydride and an imine. The metal hydride can then regenerate N-lithioethylenediamine. Through a series of elimination and substitution reactions, **11** is formed in addition to NH_3 and H_2 . This approach, however, is not an appropriate synthetic pathway to prepare tricyclic vicinal bisamidines because of the many products which would be formed when a substrate other than a symmetrical diamine was used.

Scheme 1.9

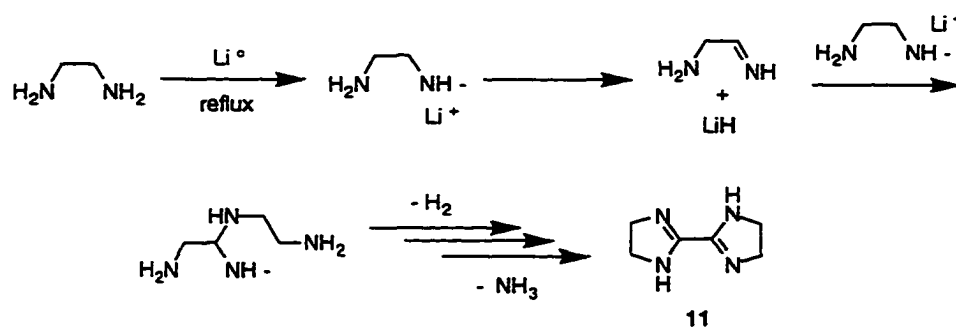

Cyanogen and derivatives thereof have also been reported in the literature to react with amines to afford bisamidines. Woodburn reported the synthesis of **11** from ethylenediamine and cyanogen, as well as the synthesis of the analogous bisamidine product from the reaction of 1,3-propanediamine and cyanogen.^{57,58} Weidinger and Kranz prepared 2,2'-biimidazoline (**11**) from ethylenediamine and ethane diimidic acid dimethylester **12**.⁵⁹ The nitrile carbons of cyanogen undergo nucleophilic attack by sodium methoxide in methanol to afford **12**. (Scheme 1.10). Searches of the chemical literature did not identify other methods for the preparation of cyclic vicinal bisamidines.

Scheme 1.10

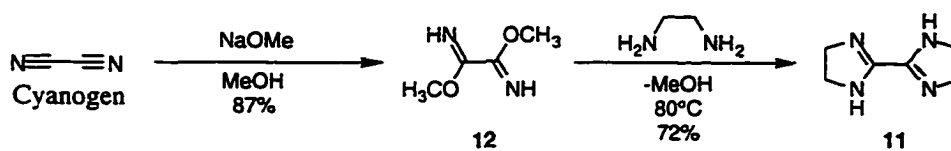

III. RESULTS AND DISCUSSION

Synthesis of 1,4,7,10-Tetraazacyclododecane (Cyclen)

The first target chosen for this study was cyclen (2). Unfortunately, the bisaminal precursor required was unavailable. Jazwinski reported that condensation of glyoxal with triethylenetetraamine results in the isomer containing more six membered rings **13** and does not afford the desired isomer **14** (Scheme 1.11).⁴⁵

Scheme 1.11

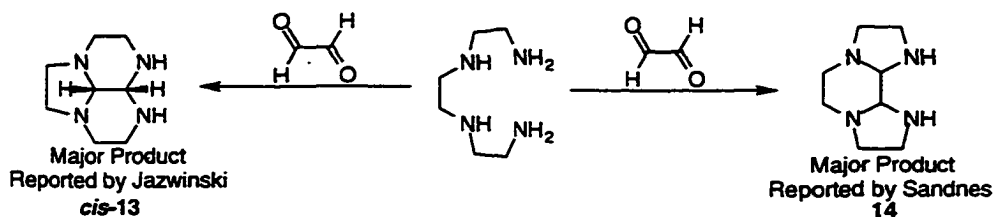

There has been some confusion concerning this reaction in the literature. Jazwinski reports the major product to be *cis*-13. Sandnes et al. report in the patent literature that cyclen was prepared, by a route different from the DIBALH route, via tricyclic precursor **14** which was prepared by reaction of triethylenetetraamine and glyoxal.⁶⁰ The reaction of triethylenetetraamine and glyoxal in CH₃CN was run in our laboratories and evaluated by ¹³C NMR only. There are four possible bisaminal isomers which could be formed in this reaction. They are shown in Scheme 1.12. The major product of the reaction was conclusively assigned as isomer *cis*-13 having two nonequivalent methine carbons and

Scheme 1.12

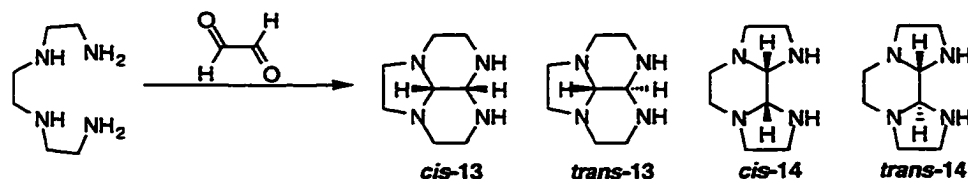

three methylene carbons. Furthermore, these resonances are dynamically broadened as a result of the enantiomerization of *cis*-13. The ^{13}C chemical shifts corresponded to those reported by Jazwinski for *cis*-13.⁴⁵ There were many other resonances which were consistent with the expected chemical shifts for the other isomers. Unfortunately, these resonances could not be assigned to specific species.

As mentioned previously, tricyclic vicinal bisamidines suitable for this project have not been reported in the literature. However, the reaction of ethylenediamine with dithiooxamide or cyanogen derivatives did afford 2,2'-biimidazoline (11) preferentially over 15 (Scheme 1.13). The reaction of dithiooxamide with triethylenetetraamine would in theory force the insertion to proceed with the same regiochemistry as 11 to afford bisamidine 16 (Scheme 1.14) which is the only logical bisamidine product. Dithiooxamide

Scheme 1.13

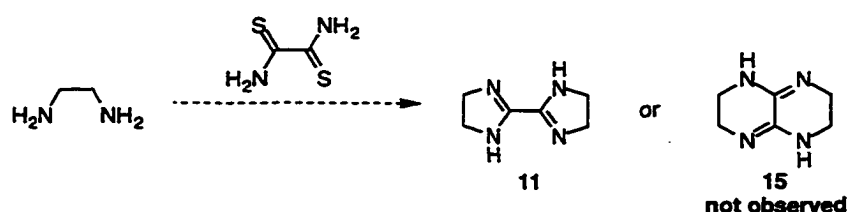

Scheme 1.14

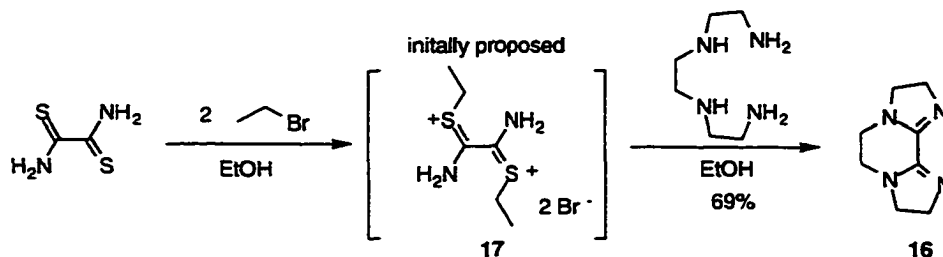

was chosen as the acylating agent because it was commercially available and, furthermore, for this chemistry to be a viable alternative to other methods for the preparation of cyclen, the use of the very hazardous cyanogen must be avoided. Utilizing the conditions for the preparation of 2,2'-biimidazoline (11) reported by Wang and Bauman, bisimidine **16** was prepared (Scheme 1.14). Introduction of bromoethane to a slurry of dithiooxamide in absolute EtOH prepared putative intermediate **17**. Excess bromoethane was removed by short path vacuum distillation to avoid alkylation of species other than dithiooxamide. The orange solid was again suspended in EtOH and a solution of triethylenetetraamine in EtOH was then added. The solution became homogeneous upon heating and afforded **16** as a white solid following sublimation. The volatile byproducts generated in this reaction (presumed EtSH and NH₃) were trapped by a gas scrubber charged with commercial laundry bleach. It was later discovered that the bleach traps were not efficient and 30% aqueous H₂O₂ was found to work more effectively. This procedure was reported in the *Journal of Organic Chemistry*.⁶¹

Upon scale up of this procedure the isolation of putative thioimidoester **17** was

attempted. In theory, this salt could be prepared in large quantities and stored for further conversion to **16** or other bisamidines. Surprisingly, all attempts to isolate **17** resulted in the recovery of dithiooxamide starting material. We contacted Prof. J.E. Bauman who confirmed that, although they stated in their publication⁵³ on the preparation of **11** that ethanethiol was generated, the identities of the volatile reaction byproducts were never determined.^{62,63} If thioimidoester **17** was not present in the reaction mixture, it is unlikely that ethanethiol was evolved in this reaction. This hypothesis is supported by a report that alkylation of dithiooxamide with alkyl halides is not a facile reaction.⁶⁴







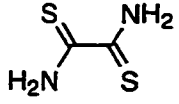

At this juncture, we began a series of experiments to establish what species were synthetically relevant in this reaction. Dithiooxamide was treated with excess bromoethane in EtOH as described for the preparation of **16**. However, when the solvent was removed by distillation, elemental analysis verified that the only species present in the residue was dithiooxamide. Unfortunately this does not prove that **17** was not formed. The alkylation of dithiooxamide by EtBr is a reversible reaction and EtBr is a highly volatile material. These two conditions allow for the possibility that **17** is formed and, in the process of removing the excess EtBr, the equilibrium of the reaction is driven back towards the reagents by the removal of EtBr. Therefore, under the conditions utilized for the preparation of **16**, it is unlikely that **17** is active as the acylating agent.

Furthermore, the reaction of dithiooxamide and triethylenetetraamine in the absence of EtBr afforded the bisamidine with no decrease in yield. Therefore, EtBr is not required in the reaction to prepare **16**. However, EtBr could, in theory, be serving as an activating

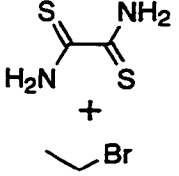
reagent, increasing the rate of the reaction. While this is unlikely because the solvent and excess EtBr are removed prior to the introduction of the tetraamine, a series of NMR experiments were carried out to disprove this hypothesis.

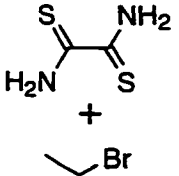
Three controls were run so the identity of all species in solution of significant concentration could be identified in either DMSO- d_6 or EtOD- d_6 . The chemical shifts for dithiooxamide and EtBr are given in Table 1.2. The solubility of dithiooxamide in EtOH at room temperature is so low that it is not detectable by NMR. Therefore, DMSO was used in order to observe all species present in the reaction. However, the reaction solvent is EtOH and it is also relevant to observe those species soluble in the reaction media. The initial experiment was the reaction of dithiooxamide and EtBr in EtOH. This heterogeneous mixture was concentrated by rotary evaporation and the residue was suspended in DMSO- d_6 . All of the EtBr had been removed and only dithiooxamide was observed in the NMR sample (Entry 1 of Table 1.2). This experiment, however, does not prove that **17** was not present prior to rotary evaporation. A second experiment was performed to address this question. The same reaction was carried out using EtOD- d_6 as the reaction solvent. The supernatant was then removed by syringe and evaluated directly by NMR (Entry 2 Table 1.2). An orange insoluble solid remained in the reaction flask. As can be seen in Table 1.1 the only species soluble in EtOD- d_6 was EtBr. DMSO- d_6 was then added to the reaction flask and the orange solid and any remaining supernatant were evaluated by NMR as well (Entry 3 Table 1.2). The NMR spectrum for the ethyl groups of **17** would be expected to be dramatically different than those of EtBr. The observed resonances in the

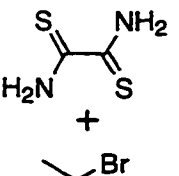
**Table 1.2: Reaction of Dithiooxamide and Bromoethane.
Reaction Conditions and NMR Data for the Reaction Products**

Sample	Reaction	NMR	δ ppm	δ ppm	δ ppm	δ ppm
A		control	DMSO-d ₆		9.58	10.18
B		control	DMSO-d ₆	1.63	3.40	
C		control	EtOD-d ₆	1.63	3.43	
1	 + 	EtOH, 4 h, 60°C remove solvent	DMSO-d ₆		9.59	10.15
2	 + 	EtOD-d ₆ 4 h, 60°C supernatant	EtOD-d ₆	1.63	3.40	
3	 + 	EtOD-d ₆ 4 h, 60°C solids	DMSO-d ₆	1.58	3.49	9.58 10.19

experimental spectrum were consistent with the control spectra for dithiooxamide and EtBr. Therefore, thioimidoester **17** is not present in any quantity detectable by NMR and is not synthetically relevant in the preparation of **16** under the conditions employed.

One significant aspect of these observations is that the volatile reaction products evolved must be ammonia and hydrogen sulfide, not ammonia and ethanethiol. While hydrogen sulfide is convenient to trap (30% aqueous NaOH instead of H₂O₂) it is much more hazardous than ethanethiol.⁶⁵ This information was published as a correction to our original paper in the *Journal of Organic Chemistry*.⁶⁶ The modified reaction has been carried out on up to 10 g of dithiooxamide starting material and **16** was obtained in 78% yield following sublimation (**16** can also be recrystallized from toluene). The bisamidine was found to be hydrolytically labile. This will be discussed later in this section.

The reduction of **16** with DIBALH afforded cyclen (**2**) which was the only product observed in this reaction (Scheme 1.15). We originally used the NaF procedure for the workup of this reaction.⁶¹ The NaF procedure is a common method for the workup of DIBALH reductions⁶⁷ and was also used by Yamamoto.³⁸ The product can be isolated

Scheme 1.15

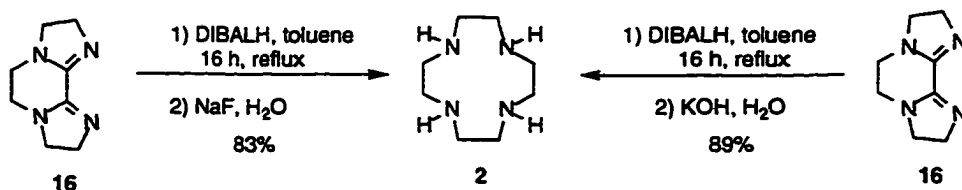

using the NaF procedure, but a Soxhlet extraction of all solids generated in the reaction was required, making this method more laborious. We later modified the reaction employing an aqueous KOH workup for the DIBALH reduction. The aqueous KOH method avoids heterogeneous mixtures allowing for a simple liquid-liquid extraction to isolate the crude product. The reduction has been carried out utilizing the aqueous KOH method on up to 10 g of bisamidine with a yield of 89% (Scheme 1.15).

At the request of the editors of *Organic Syntheses* this new method for the preparation of cyclen has been submitted for publication. The procedure was written to include the modifications in the reduction workup and is currently undergoing the checking process. The procedure as well as the discussion section, as submitted to *Organic Syntheses*,⁶⁸ can be found in the Appendix Section of this dissertation.

This two step preparation of cyclen has an overall yield of 69% from triethylenetetraamine. The starting materials are relatively inexpensive, commercially available materials. The only significant drawback to this chemistry is the evolution of hydrogen sulfide. However, on the modest scale of 10 g, the quantity of hydrogen sulfide generated can be easily trapped with aqueous-base filled gas scrubbing bottles. The simple, inexpensive method reported here to prepare cyclen is a viable alternative to other chemical preparations previously discussed. This two-step approach is synthetically much simpler than the Richman-Atkins method which was considered to be the method of choice to prepare cyclen. A 52% yield was the best result found in the chemical literature for preparation of the tetrahydrochloride salt of cyclen using the Richman-Atkins method.⁶⁹

Scheme 1.16

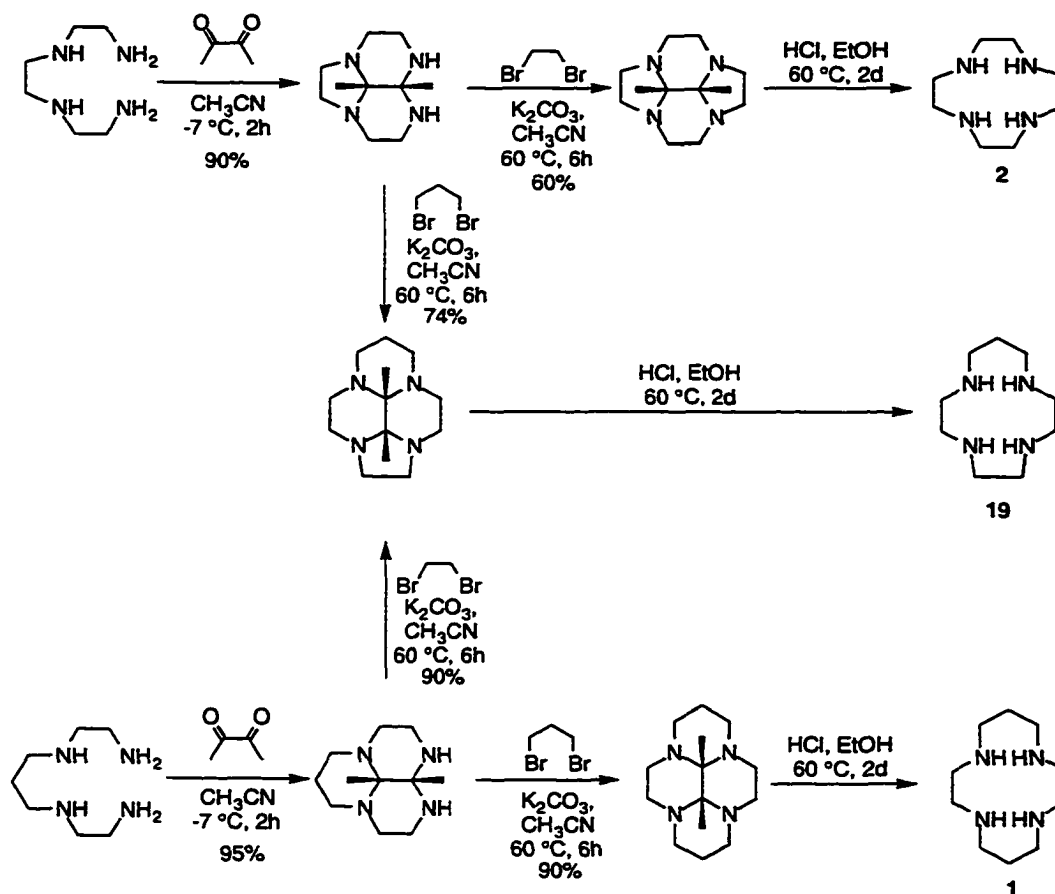

This result was for the cyclization and detosylation steps and does not include the preparation of the two precursors.

Recently, a new route for the preparation of cyclen (**2**), cyclam (**1**) and 13[ane] N_4 (**19**) has recently been developed by Hérve and coworkers.⁷⁰ This new method also boasts high atom economy using a diketone as an exo-template. As shown in Scheme 1.16, a linear tetraamine is reacted with 2,3-butanedione to afford a tricyclic vicinal bisaminal. The bisaminal can then be further cyclized to afford a tetracyclic bisaminal. The exo-template (2,3-butanedione) is then removed in good yield by acidic hydrolysis. This three step

sequence affords cyclen as the hydrochloride salt in an overall yield of approximately 50%.⁷⁰ Cyclam (1) and 13[ane]N₄ (19) were also reported to be prepared in comparable yield. This process, however, includes an extra step and yields are lower, but this method does avoid H₂S and DIBALH which are advantages over our approach. This route is a viable alternative to our methodology.

Synthesis of 1,4,7,10-Tetraazacyclotridecane.

The required tetraamine (1,4,7,10-tetraazaundecane) for the preparation of bisamidine **18** was commercially available as the tetrahydrochloride salt. Isolation of the free amine followed by reaction with dithioamide under the same conditions as used for the preparation of **16** afforded bisamidine **18**. This reaction has been carried out on up to a 4 gram scale in 58% yield. Reduction of bisamidine **18** with DIBALH cleanly gave 1,4,7,10-tetraazacyclotridecane (**19**) in 89% yield after sublimation. This sequence is shown in Scheme 1.17. Hung has reported the synthesis of **19** using the Richman-Atkins-Stetter approach.⁷¹ The synthetic sequence included four steps from 1,4,7,10-

Scheme 1.17

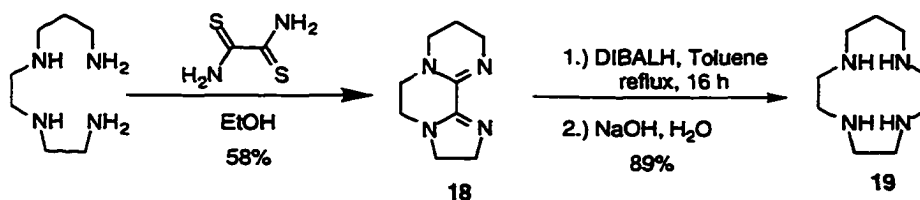

tetraazaundecane and had an overall yield reported to be 17-26%. Our new methodology provided 1,4,7,10-tetraazacyclotridecane in two steps from 1,4,7,10-tetraazaundecane in 52% yield.

Synthesis of 1,4,8,11-Tetraazacyclotetradecane (Cyclam)

Jazwinski reported the condensation of glyoxal with 1,3-propanediamine.⁴⁵ In this case, the major product was reported to be 2,2'-bihexahydropyrimidine **20** whereby the two-carbon unit was inserted such that the desired bisaminal with two 6-membered rings was formed. Jazwinski further elaborated **20** to tricyclic bisaminal **21** and determined the stereochemistry of the ring fusion to be *trans*.

Condensation of glyoxal with 1,3-propanediamine in our laboratory gave 2,2'-bihexahydropyrimidine in a 37% yield under the conditions reported by Jazwinski. In our hands, treatment of 2,2'-bihexahydropyrimidine (**20**), prepared by the literature method, with glyoxal followed by reduction with NaBH₄ did not give a clean reaction product but a mixture of two species (Scheme 1.18). The major product was identified as the *trans*-perhydropyrimidopyrimidine (*trans*-**21**) reported by Jazwinski. The spectral

Scheme 1.18

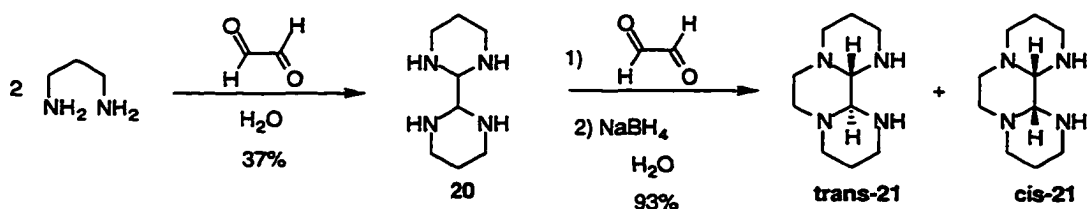

Scheme 1.19

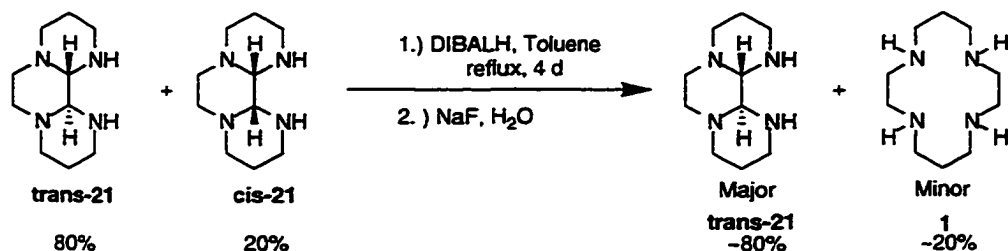

characteristics of the minor product were consistent with the *cis* isomer (*cis*-21). NMR analysis estimated the composition of this mixture to be approximately 80:20 (*trans*:*cis*).

The *trans* isomer was purified by fractional recrystallization, however, the postulated *cis* isomer was never isolated in sufficient purity to be fully characterized.

DIBALH reduction of the crude bisaminal mixture believed to be *trans/cis* perhydrotetraazaphenanthrene afforded a mixture of *trans*-21 and cyclam (1). Surprisingly, the minor component postulated to be *cis*-21 had been completely consumed and the *trans*-21 starting material was almost quantitatively recovered (Scheme 1.19).

Reaction of *N,N'*-bis-(2-aminopropyl)-ethylenediamine (22) with dithiooxamide provided bisamidine 23 (Scheme 1.20). However there was another

Scheme 1.20

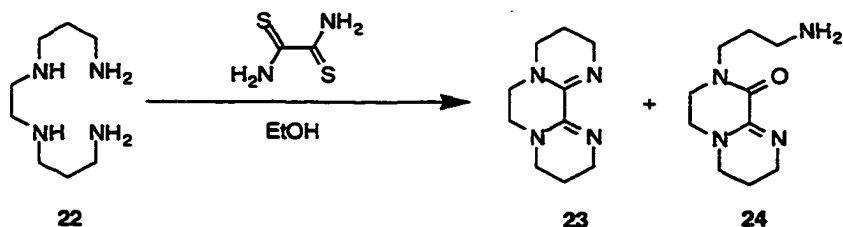

complication which had not occurred in the previously discussed bisamidine syntheses.

The major component of the reaction mixture **23**, was contaminated with a second species.

This species was determined by NMR analysis to be **24**. Hydrolysis of **23** by one equivalent of H_2O could give rise to **24**.

This hypothesis was confirmed by a series of NMR experiments on the crude reaction product. Scheme 1.21 shows the results of these experiments. Hydrolysis of the crude reaction mixture with D_2O in an NMR tube gave a single species in solution consistent with **25**. Rotary evaporation of the solvent with added absolute EtOH to azeotropically remove the water resulted in partial dehydration of bisamide **25**. NMR analysis (CDCl_3) after rotary evaporation identified bisamide **25** as the major component along with dehydrated species **24**. This result suggested that the crude product from the reaction of dithiooxamide and the tetraamine **22** might also be dehydrated to give only bisamidine **23**. Azeotropic distillation of the crude bisamidine mixture with toluene for 3 days gave **23** of sufficient purity (~90%) for attempted reduction. The yield of **23** was approximately 25% following dehydration. Further discussion of the hydrolysis of tricyclic bisamidines can be found later in this section.

Scheme 1.21

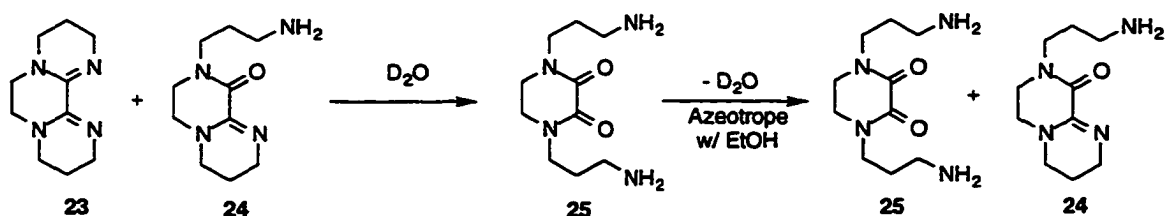

Scheme 1.22

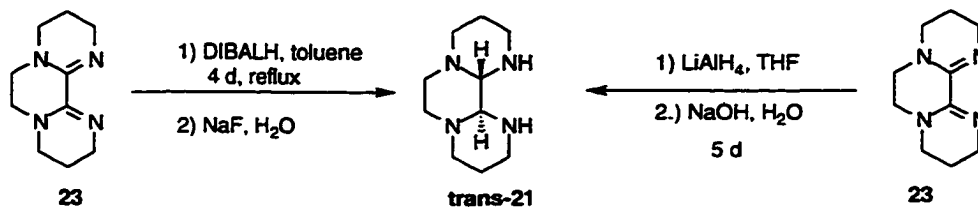

Unfortunately, DIBALH reduction of bisamidine **23** resulted in *trans-21* as the only product. No starting material was observed nor was further reduction to cyclam. Even under conditions using longer reaction times or large excesses of DIBALH only *trans-21* was observed. Reduction of **23** with LiAlH₄ similarly resulted in the formation of *trans-21* only (Scheme 1.22). From these results it is reasonable to propose that bisamidine **23** is initially reduced such that the two hydrides have been delivered *trans* to each other. This intermediate is common to the previously discussed failed reduction of *trans-21* and further reduction of this species to cyclam is apparently unfavorable.

However, the reduction of the crude *trans/cis-21* gave cyclam and unreacted *trans-21*. Therefore, it is reasonable that the *trans* stereochemistry of the ring junction is the controlling factor in the susceptibility of this ring system towards reduction. We have rationalized two qualitative arguments to explain the observed results. As shown in Scheme 1.23, the reduction process for each aminal moiety of the *cis/trans-21* mixture can be divided into three steps. The first step is deprotonation of the aminal to afford *cis-26* and *trans-26*. The second step, for an imine mediated mechanism, is the reversible process to afford imines **27** and **27'**. The final step is the DIBALH reduction of **27** and **27'**. It is

Scheme 1.23

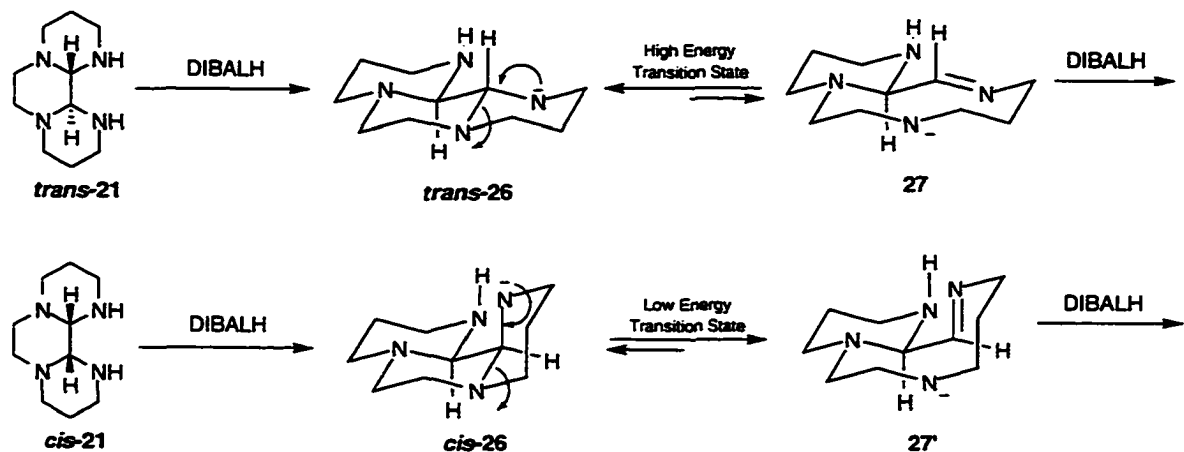

possible that *trans*-21 is robust towards reduction because of strain introduced into the transition state of a rate determining step from *trans*-26 to 27. Alternatively, there is a pre-equilibrium of *trans*-26 and 27 preceding a rate determining step. Strain introduced into 27 may result in a large difference in energy between *trans*-26 and 27 making this equilibrium largely favor *trans*-26 over 27. In either case, the pathway from *cis*-26 to cyclam must not introduce strain in the transition state that leads to 27' or in imine 27' relative to the *trans* isomer.

Synthesis of Benzocyclam

This methodology was extended to the preparation of benzocyclam. The preparation of benzocyclam is unreported in the literature but there is a report on its photoelectron (PE) spectrum.⁷² The introduction of one unsaturation into the central ring of this system will distort the conformation of the reactive intermediate 29, with respect to

Scheme 1.24

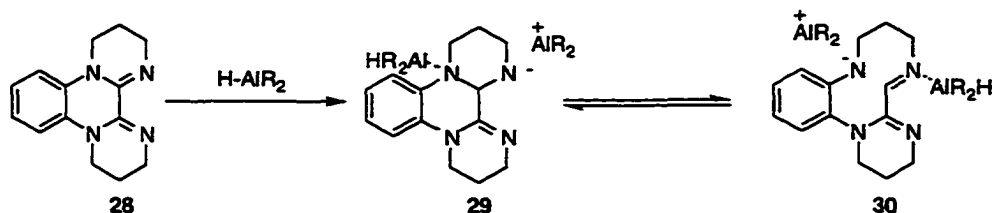

the saturated case (21), which might facilitate ring opening. Furthermore, as can be seen in Scheme 1.24, if an equilibrium between 29 and 30 was established, species 30 should be favored as a result of the electronic effect of the adjacent aromatic ring. Either or both of these factors may be operative. In any event, both factors would facilitate the formation of the ring opened product 30.

N,N'-bis(3-aminopropyl)-1,2-phenylenediamine (31) is the appropriate tetraamine required for the preparation of a tricyclic bisamidine precursor for benzocyclam (Scheme 1.24). This tetraamine was unreported in the literature. However the preparation of a possible precursor, *N,N'*-bis-(2-cyanoethyl)-1,2-phenylenediamine (32), had been reported.⁷³ Reaction of 1,2-phenylenediamine with acrylonitrile in CH₃CN under the catalysis of cupric acetate (Cu(OAc)₂) did afford 32 in 22% yield after recrystallization (Scheme 1.25). Even though this yield is poor, the low cost of the reagents and the ability to easily run this reaction on 50-100 gram scale allows for the preparation of multi-gram quantities of 32.

Reduction of 32 with AlCl₃/NaBH₄⁷⁴ in THF afforded *N,N'*-bis(3-aminopropyl)-1,2-phenylenediamine (31) in 61% yield following Kugelrohr

Scheme 1.25

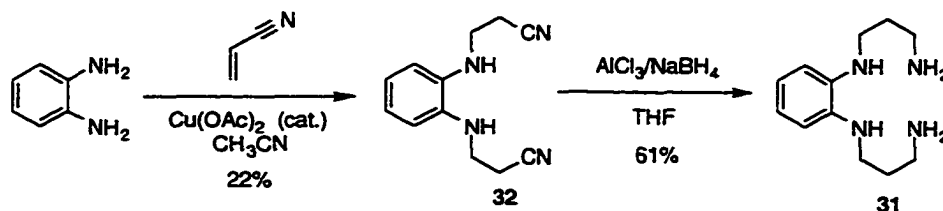

distillation (Scheme 1.24). The reduction was also performed using $\text{BH}_3 \cdot \text{THF}$ in ~95% yield on less than a one gram scale. Upon scale up (~5 gram scale), these yields fell dramatically and typically a 50% yield was realized. The $\text{AlCl}_3/\text{NaBH}_4$ method was chosen because the $\text{BH}_3 \cdot \text{THF}$ method was more laborious and expensive while affording comparable yields. 1,2-Phenylenediamines are susceptible to oxidation as free amines and, as a result, **31** is extremely labile towards oxidation by atmospheric oxygen. This oxidation can be avoided by treating 1,2-phenylenediamines with strong acids and storing them as salts. In the workup of the $\text{AlCl}_3/\text{NaBH}_4$ reduction all solutions were carefully purged of oxygen and kept under N_2 . A continuous extraction was employed in order to isolate the product from the basic reaction medium and the operation was carried out under a N_2 atmosphere. The crude product was a brown oil which was purified to a yellowed oil which solidified in the receiver following Kugelrohr distillation.

Unfortunately, cyclization of **31** with dithiooxamide did not provide desired bisamidine **28** (Scheme 1.26). However, the condensation of **31** with glyoxal in $\text{EtOH}/\text{CH}_3\text{CN}$ (1:1) did afford **33** as a mixture of diastereomers in 89% yield (Scheme 1.27). The diastereomeric ratio of this mixture was estimated to be 3:1 by ^1H NMR

Scheme 1.26

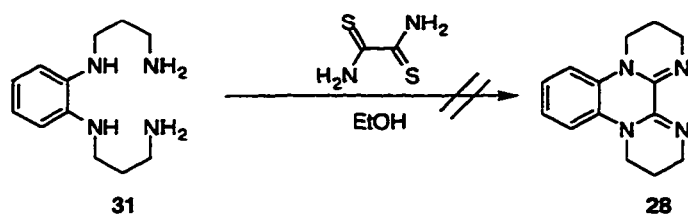

integration. This mixture was robust towards oxidation and showed no signs of oxidative degradation after three weeks of storage. The two diastereomers were never separated and it was never determined conclusively which isomer was in greater abundance in the reaction product.

Scheme 1.27

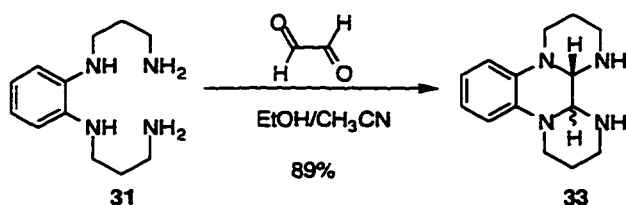

Reduction of **33** with DIBALH gave benzocyclam (**34**) (Scheme 1.28). An ethanolic solution of the crude reaction product was treated with 12M HCl to prohibit oxidation. Concentration of this solution by rotary evaporation gave a pink powder.

Scheme 1.28

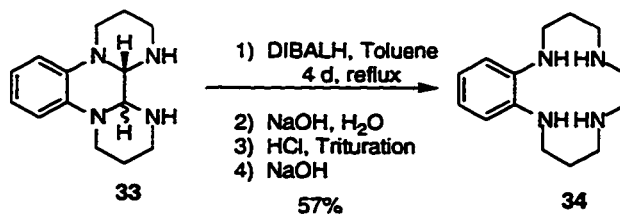

Trituration of this powder with hot EtOH removed the color from the solid and afforded a white powder following vacuum filtration. Liberation of the free amine by base extraction afforded **34** in a 57% yield.

Attempted Synthesis of a Bisamidine Precursor for 1,4,7,11-Tetraazacyclopentadecane and Alternative Precursor for 1,4,7,10-Tetraazacyclotridecane.

Reaction of N,N'-bis(2-aminoethyl)-1,3-propanediamine with dithiooxamide might be expected to afford bisamidine **35**, which would be another precursor to 1,4,7,10-tetraazacyclotridecane (**19**). This sequence is shown in Scheme 1.29.

Unfortunately, this reaction did not proceed cleanly. Spectra of the crude product did support product formation but there were multiple unexplained resonances also present which did not correspond with starting material or hydrolyzed bisamidine product. These signals are most likely due to either product decomposition or alternate chemistry leading to unwanted byproducts. Lengthening or shortening reaction time did not enhance the ratio of product to the impurities and conditions to optimize the yield of the bisamidine formation

Scheme 1.29

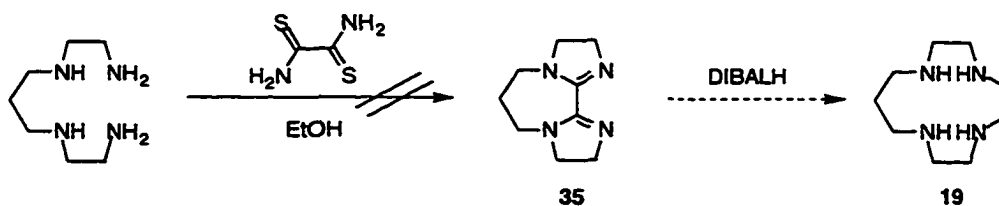

were not found. To further complicate matters, purification of the bisamidine product was unsuccessful.

Similar difficulties were encountered in the reaction of *N,N'*-bis(3-aminopropyl)-1,3-propanediamine with dithiooxamide. This reaction should provide **36** which, following successful DIBALH reduction, would afford **37** (Scheme 1.30). There were NMR data which supported product formation but the identity of the majority of material in the sample is unknown. Purification of this crude mixture was unsuccessful and purified **36** was never obtained.

Scheme 1.30

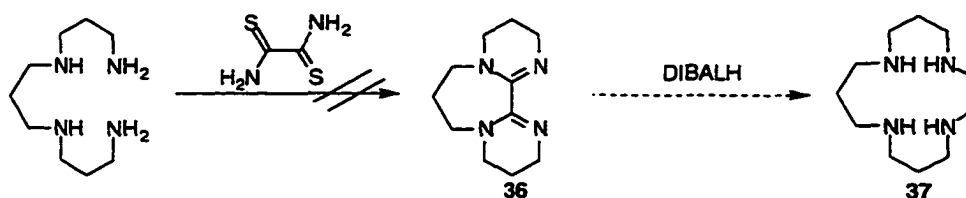

Investigation of Reagents for Bisamidine Formation Other Than Dithiooxamide.

Dithiooxamide, while effective for the preparation tricyclic bisamidines, was by far the most expensive reagent in this new methodology. More significantly, the generation of hydrogen sulfide also makes the scale up of these reactions less attractive because of inefficient trapping of the gaseous byproducts would be dangerous. Therefore, finding an alternative reagent for introduction of the two amidine carbons would be an improvement in the methodology.

Simple, readily available, reagents such as oxamide, diethyloxalate and oxalic acid all failed to provide **16** when reacted with triethylenetetraamine under a variety of conditions. As previously mentioned, another alternative is cyanogen or a derivative thereof. The Pinner method for the formation of amidines from nitriles has been well documented.^{49,75,76} In this method, a nitrile is converted to an imido ester, which is converted to the amidine. A derivative of cyanogen such as ethane diimidic acid dimethylester **12** (Scheme 1.10, pg 15) would be an ideal reagent since the byproducts would be an alcohol and an amine, posing no difficulties. There are procedures for the safe generation and use of cyanogen, but overall cyanogen presents a far greater problem than hydrogen sulfide.⁷⁷⁻⁷⁹ Therefore, another means of preparing **12** is desirable.

Kantlehner et al. have investigated the alkylation of an oxamide derivative with trimethyloxonium tetrafluoroborate.⁸⁰ They have reported that initial treatment of N,N,N',N'-tetramethyloxamide (**38**) with trimethyloxonium tetrafluoroborate affords **39** where one oxygen has undergone alkylation (Scheme 1.31). This species then reacted with an equivalent of amine to give **40**. Further reaction of **40** with trimethyloxonium tetrafluoroborate was incomplete but did provide dication **41**. Introduction of another equivalent of amine however, afforded three products; the expected dication of tetrakis-(dimethylamino)-ethylene **42**, **40** and a quaternary ammonium salt. Therefore **41** would not be an appropriate candidate for a dithiooxamide synthon because introduction of triethylenetetraamine would likely lead to a mixture of products.

However, we hypothesized that the dication of tetrakis-(dimethylamino)-ethylene

Scheme 1.31

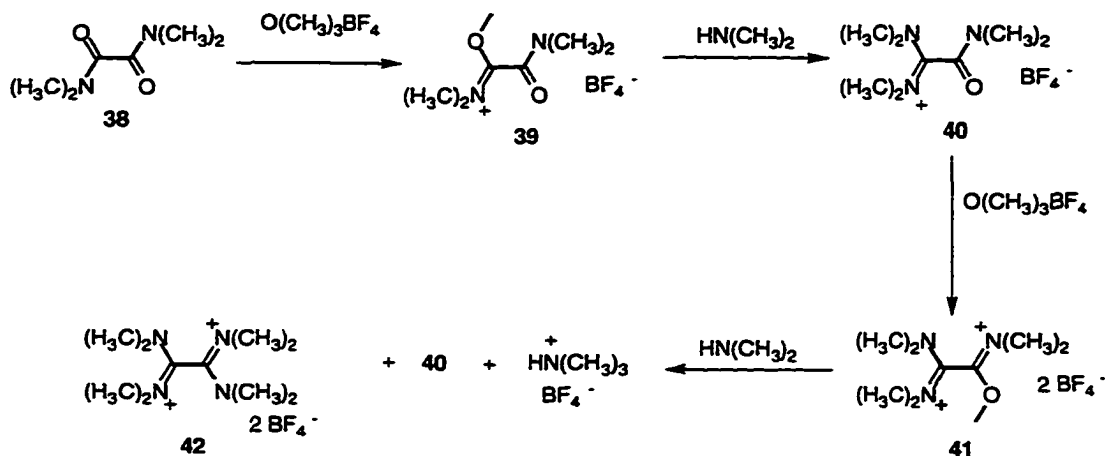

may be a suitable candidate. The appeal of this synthon is, during the acylation reaction, dimethylamine would be the byproduct and the reaction could be driven by the generation of gaseous byproducts. This idea is shown in Scheme 1.32 where dimethylamine is the low molecular weight amine byproduct. Fortunately, dications such as **42** are readily available from oxidation of the appropriate tetraaminoethylene.⁸¹ Treatment of an ether solution of tetrakis-(dimethylamino)-ethylene (**43**) with bromine according to the literature procedure⁸¹ afforded the desired oxidized product **44** in 93% yield (Scheme 1.33).

Scheme 1.32

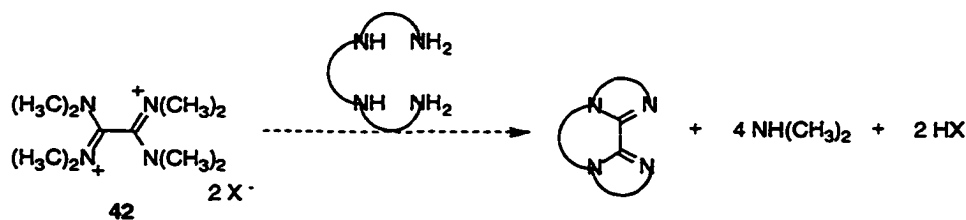

Scheme 1.33

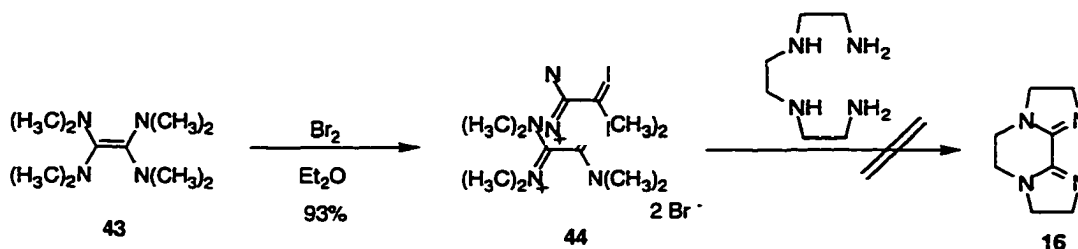

Treatment of **44** with triethylenetetraamine did not cleanly provide **16**. The most promising result was obtained from the neat reaction of **44** and triethylenetetraamine. While evidence for the formation of **16** could be seen by NMR, the majority of the reaction product was unidentified. It is possible that the competing polymerization reaction between **44** and triethylenetetraamine was more facile than the cyclization reaction to afford **16** under the conditions investigated. Furthermore, a dealkylation reaction could take place which would transfer a methyl group to triethylenetetraamine complicating the formation of **16**. Other reaction conditions included the use of alcoholic solvents (ethanol, isopropanol and *n*-butanol) but we were unable to find conditions that gave **16** as the major product. These solvents could also react with **44** to give thioimidic esters causing further complications in the reaction. At this juncture, it was determined that dithiooxamide was the best synthon for this chemistry and further attempts to replace it were abandoned.

Attempted Preparation of Dibenzotetraaza Macrocycles

Thummel has reported the preparation of a number of tricyclic bibenzimidazoles and

the conditions required to prepare these substrates from 2,2'-bibenzimidazole (**45**).⁸²

Thummel et al. also reported that species **46** (see Scheme 1.34), where the central ring is a six membered ring, could not be prepared under any conditions they employed.

Furthermore, there are only two citations in the literature for this compound and both report poor yields (~10%) for the desired product.^{83,84}

2,2'-Bibenzimidazole (**45**) was required for the preparation of 6,7-dihydropyrazino[1,2-a:4,3-a']bisbenzimidazole (**46**). The preparation of 2,2'-bibenzimidazole has been reported by Fieselmann.⁸⁵ The reaction of 1,2-phenylenediamine and oxamide afforded **45** in 68% yield in our hands. A method was developed to cyclize this substrate to **46** by deprotonation of **45** with NaH in DMF followed by the addition of 1,2-bis[*p*-tolylsulfonyl]oxy]ethane. The procedure used was similar to the method reported by Roechling.⁸³ The mixture was heated at reflux for 7 days and afforded 8% yield of **46** after recrystallization. Possible complications leading to the low yield could arise from elimination reactions which take place on the alkylating agent. Ring closure might also be slow as a result of the strain introduced in addition to the poor

Scheme 1.34

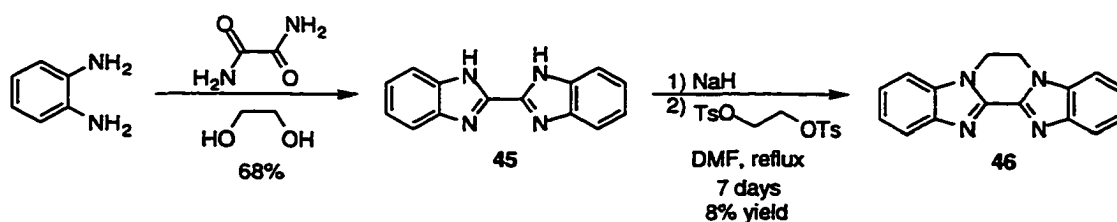

Scheme 1.35

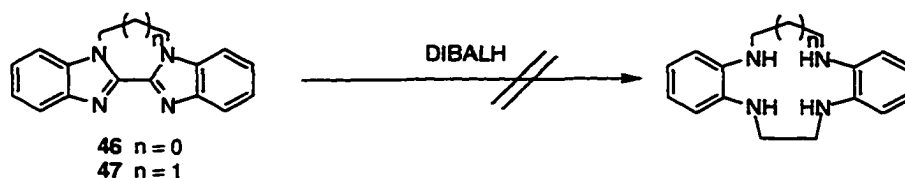

trajectory the incoming nucleophile is forced to accommodate in this S_N2 reaction.

Nevertheless, **46** was obtained in sufficient quantity and purity for attempted reduction.

The regioselective DIBALH reduction of **46** was attempted using the conditions which were found to be successful with other bisamidines. Unfortunately, the reaction did not proceed cleanly and the identities of the reaction product(s) were never conclusively determined (Scheme 1.35). Increased reaction times and increasing the number of equivalents of reducing agent did not improve the results. The best hypothesis for the outcome of this reaction supports incomplete reduction of **46**. MS data gave a molecular ion which was consistent with cleavage of only one amidine moiety of **46**. Furthermore, compound **47**, which was also prepared from 2,2'-bibenzimidazole, also failed to undergo clean reduction by DIBALH. As a result, no dibenzotetraaza-macrocycles have been prepared by this methodology.

Attempted Preparation of Bisamidines from 2,2'-Biimidazoline

There is a potential synthetic pathway to many different bisamidines starting from 2,2'-biimidazoline (**11**). For example, alkylation of **11** with a ditosylate or a dihalide

Scheme 1.36

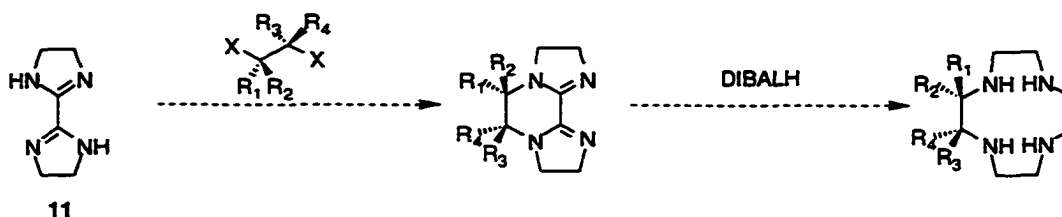

could lead to tricyclic vicinal bisamidines. The significance of establishing this methodology would be that this route could allow for the preparation of C-functionalized tetraazacycloalkanes. This idea is shown in Scheme 1.36. It would be much simpler to prepare C-functionalized analogues from the parent bisimidine, **11**, than to go back into the synthetic method and develop a strategy to incorporate functional groups into the carbon backbone of the linear tetraamine.

The initial target for this idea was to prepare bisamidine **16**, the cyclen precursor. This was an ideal choice because the amidine was already well characterized and the ring closure forms a six membered ring. 2,2'-Biimidazoline was prepared in 56% yield by the reaction of ethylenediamine and dithiooxamide. The product was purified by recrystallization from CH₃CN and was found to be insoluble in most common solvents. 1,2-Dibromoethane was introduced to a suspension of **11**, KI and K₂CO₃ in CH₃CN and the resulting mixture was heated at reflux for 20 hours (Scheme 1.37). Unfortunately, ring closure was not facile and no evidence for the formation of **16** was found by NMR. The ability of the 2,2'-biimidazoline to hydrogen bond intermolecularly might decrease the nucleophilicity of the amidine moiety making the reaction less favorable than anticipated.

Scheme 1.37

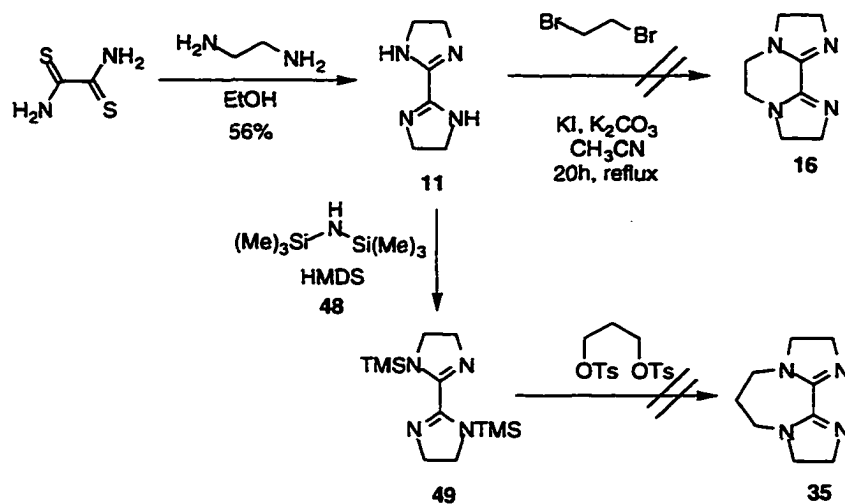

Reaction of 2,2'-biimidazole with hexamethyldisilazane (HMDS) **48** has been reported in the literature to afford **49** in good yield.⁸⁶ **49** was prepared by this method. As shown in Scheme 1.37, the cyclization reaction between **49** and propyleneglycol ditosylate unfortunately did not afford bisamidine **35** after refluxing in CH_3CN for 1 day. While these few attempts at preparing a tricyclic bisamidine from 2,2'-biimidazole were not successful, further attempts under different reaction conditions such as different solvents (DMSO, DMF or DMPU) or using the sodium salt of 2,2'-biimidazole need to be explored.

Hydrolysis of Vicinal Bisamidines

As mentioned previously, tricyclic vicinal bisamidines react with water readily to form bisamides. The hydrolyses of bisamidines **16**, **18** and **23** have been investigated.

Scheme 1.38

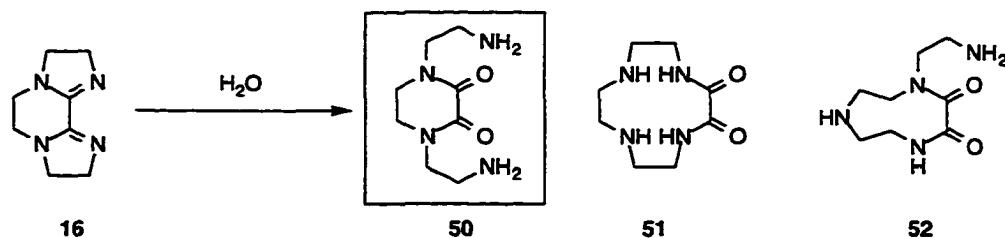

There is the possibility that each amidine moiety can be fully hydrolyzed in either of two ways leading to three possible products from a symmetrical bisamidine. This is shown in Scheme 1.38 for bisamidine **16**. However, for **16**, only one of these isomers was observed. In an NMR experiment, **16** was dissolved in D₂O and only **50** was observed. The ¹H NMR spectrum is shown in Figure 1.1. The unsymmetrical isomer **52**, which would have eight ¹³C resonances (two in the carbonyl region), can be eliminated based on the relatively few resonances in the ¹H and ¹³C NMR spectra which dictate that the product must have a high degree of symmetry. The ¹³C spectrum had only four resonances, which is consistent with either **50** or **51**. The assignment of the structure as **50** rather than **51** is based primarily on the chemical shift of the methylene hydrogens adjacent to the primary amino group at 2.7 ppm. It would be expected that the ¹H chemical shift for the singlet of **51** would be very close to the triplet at 2.7 ppm because they are both adjacent to the secondary amino group. However, the singlet in the observed ¹H spectrum is very close to the downfield triplet for the methylene adjacent to the amide moiety. This is most consistent with isomer **50**. In all cases studied, the bisamidine moiety hydrolyzes regioselectively to give a 6-membered cyclic tertiary bisamide with two primary amino chains. Bisamidines

Figure 1.2: ^1H NMR Spectra for 16 and 50.

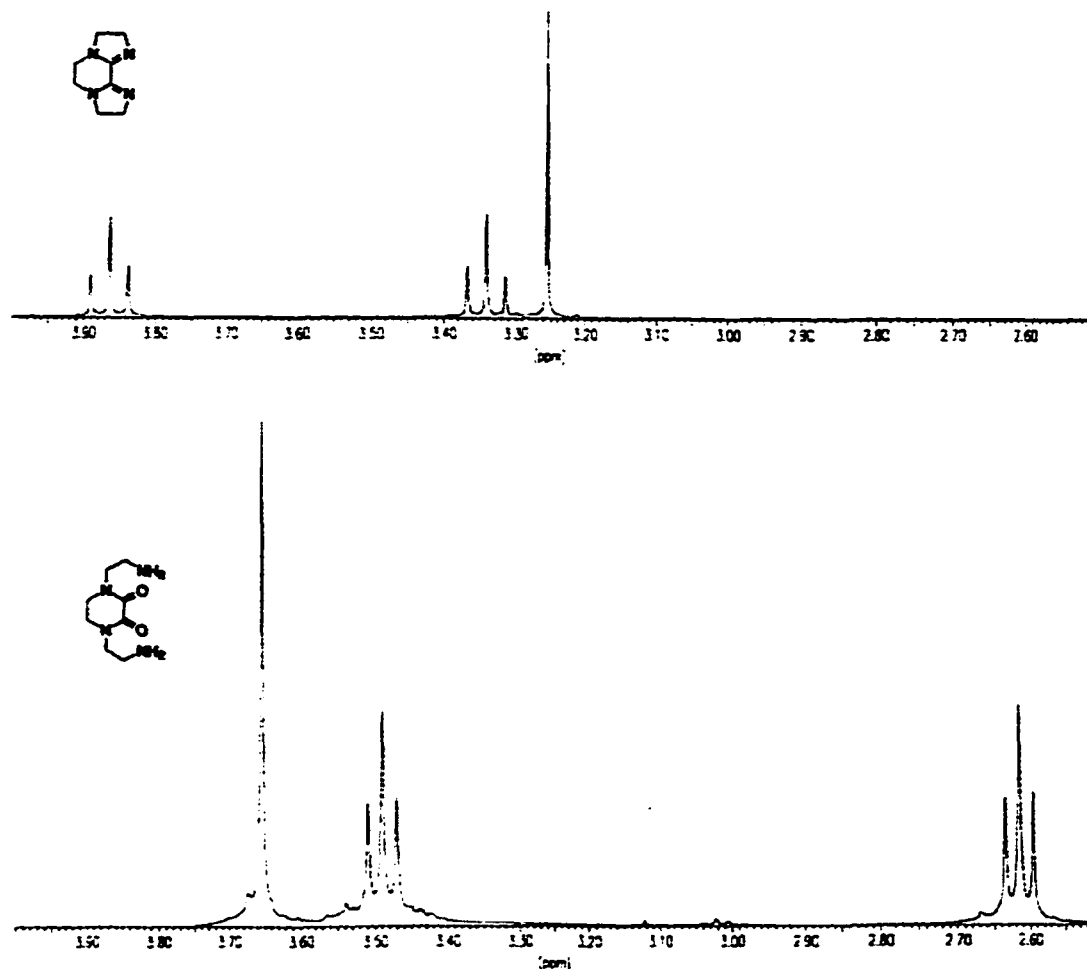

18 and **23** gave results analogous to **16** as shown in Scheme 1.39. Unfortunately, attempts to isolate and characterize these bisamides gave mixtures of amides and monoamide-monoamidines. Furthermore, ^1H NMR data for the material isolated from D_2O for **53** was most consistent with a mixture of **53** and **54**.

Scheme 1.39

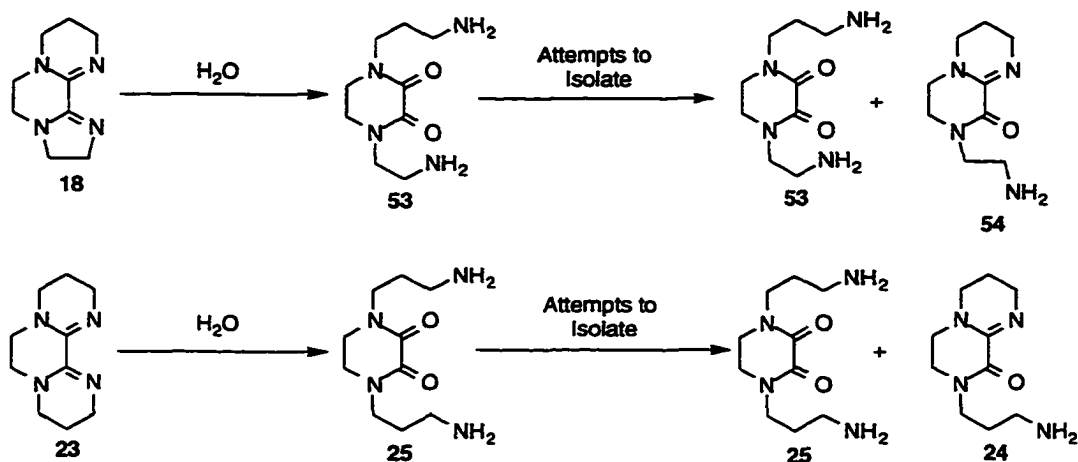

As mentioned briefly in the discussion of the preparation of bisamidine 23, a mixture of bisamidine 23 and monoamide-monoamidine 24 was dehydrated by azeotropic distillation with toluene. This process is shown in Scheme 1.40. Azeotropic distillation of 50 with toluene with a Dean-Stark trap similarly afforded 16. While never investigated, addition of catalytic acid or base should facilitate this process, which may prove to be a useful synthetic tool in future experiments.

Scheme 1.40

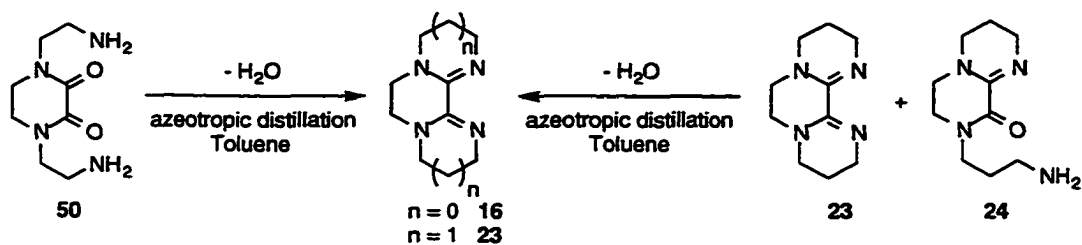

Transamidation (“Zip”) Reaction of Bisamide 51.

It would have been a fortuitous result to have obtained **55** over **25** in the hydrolysis of **23** (Scheme 1.41). For those bisamidines which do not undergo DIBALH reduction efficiently, an alternative synthetic route to the tetraazacycloalkane might have been to reduce the cyclic secondary amides. For example, isolation of **55** could give cyclam (**1**) upon reduction of the amide moieties as shown in Scheme 1.41. Macrocyclic bisamides such as **55** would also be interesting ligands for metal complexation. One example has been reported by Aqra et al., who have described the preparation of **51** (Scheme 1.42) from triethylenetetraamine and diethyloxalate.⁸⁷ This compound was prepared to study complexes with various transition metals. However, sufficient evidence for the characterization of **51** was not presented in this paper. Recently, another group has reported the synthesis of **51** and its subsequent reduction to cyclen (**2**) with $\text{BH}_3\text{-THF}$.⁸⁸ Again **51** was prepared from the reaction of triethylenetetraamine and diethyloxalate. The reaction of these two reagents was briefly investigated as a possible route to tricyclic bisamidine **16** as mentioned previously. Furthermore, this reaction was also investigated

Scheme 1.41

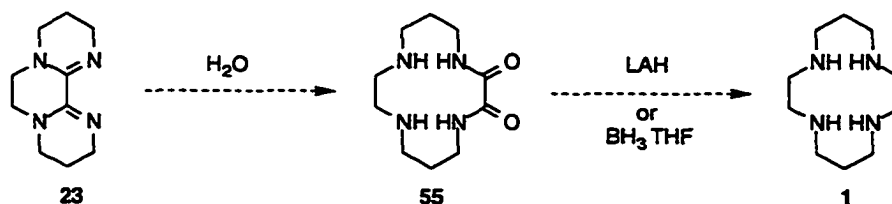

Scheme 1.42

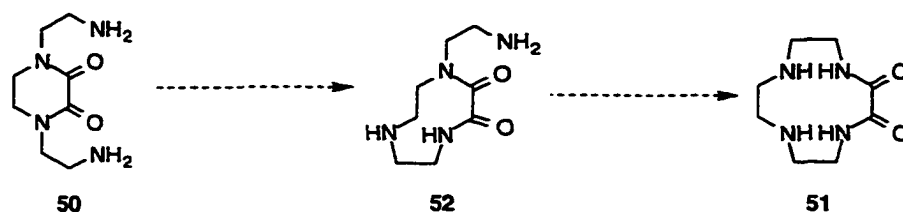

using the conditions reported by Aqra and no conclusive evidence for the formation of **51** was obtained.⁸⁹ Bisamides of other ring sizes, such as **55**, have not been reported.

Hesse has reported transamidation reactions coined as “Zip reactions” which involve amide and amino moieties.⁹⁰⁻⁹² We believed this chemistry might be useful in the conversion of **50** to **51** (Scheme 1.42). “Zip reactions” are also endo-templated reaction (see Figure 1.1, pg 12).⁴³ This type of endo-templated reaction proceeds by the insertion of a side chain into the ring, resulting in a ring expansion. A “Zip reaction” may often takes place repeatedly in a cascade manner. This idea is illustrated in Figure 1.3. An

Figure 1.3: Endo-Templated “Zip Reaction”

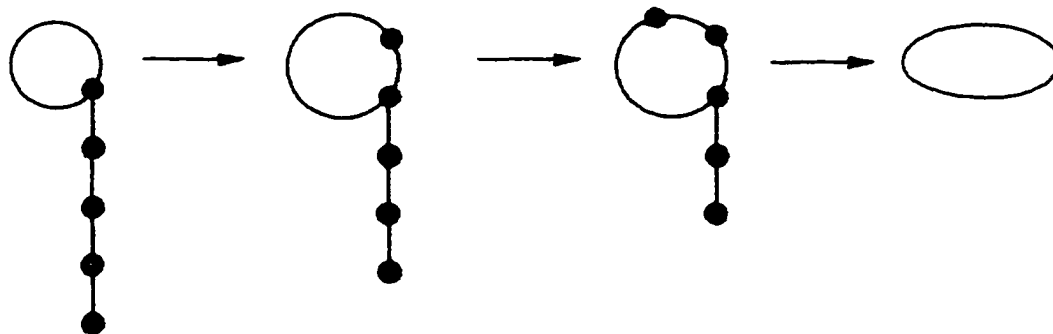

Scheme 1.43

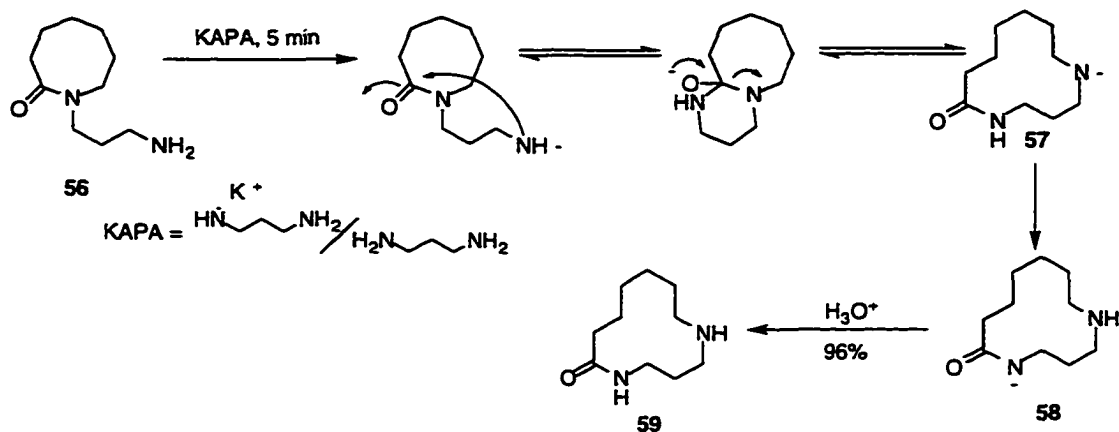

example of this chemistry is shown in Scheme 1.43. The “Zip reactions” proceed by the nucleophilic attack of the amino nitrogen on the amide carbon, forming a tetrahedral intermediate. This intermediate can then close down breaking the C-N bond to transamidate the substrate. These reactions are often run under thermodynamic control and are driven by the difference in acidity between amino and amide protons (approximately 20 orders of magnitude in water). **56** can be ring-expanded to **59** following treatment with KAPA.⁹² **57** is the conjugate base of a secondary amine, which is a much less stable anion than the deprotonated amide **58**. Therefore the equilibrium between **57** and **58** is driven to **58** and the ring expanded amide **59** is the major product.

A similar situation could be set up between **50** and **51** to ring expand the 6-membered ring into the 12-membered ring. The proposed transamidation reaction is shown in Scheme 1.44. Treatment of **50** in toluene with potassium *tert*-butoxide at reflux did not afford **51** as the major product. The presence of the base did not drive the equilibrium to

Scheme 1.44

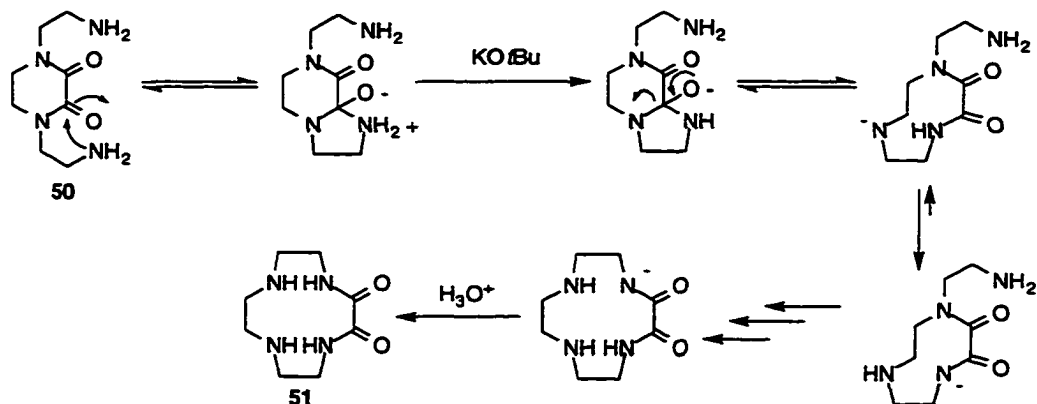

the desired secondary amide but instead facilitated dehydration to give the parent bisamidine (16) (Scheme 1.45). Dehydration was also the more favorable process when the solvent was changed to isopropyl alcohol. Unfortunately, conditions were not found which favor transamidation over dehydration for these compounds. Further work in this area is needed which should include the use of stronger bases, such as KAPA, and other solvents.

Scheme 1.45

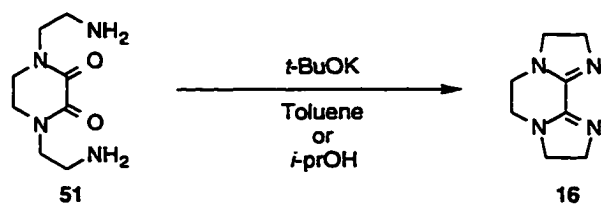

Protonation of 2,3,5,6,8,9-Hexahydrodiimidazo[1,2-a:2',1'-c]pyrazine (16) in CD₃CN.

Protonation of **16** with trifluoroacetic acid (TFA) in CD₃CN was investigated in an NMR experiment. Introduction of 0.5 equivalents of acid to the bisamidine shifted the resonances for each methylene downfield as seen in Table 1.3. A broad singlet for the acidic proton was found at 8.11 ppm. Addition of another 0.5 equivalents of TFA further shifted this resonance to almost 9 ppm. Some sample degradation was observed at this juncture likely due to hydrolysis. There are also significant upfield shifts observed in the ¹³C resonances. The most dramatic change is for the amidine carbon. The protonation of the amidine moiety shifts this resonance almost 2 ppm upfield upon the addition of a full equivalent of acid.

Table 1.3: NMR Data for the Protonation of 16 with TFA.

1H NMR			13C NMR		
0 eq. TFA	0.5 eq. TFA	1 eq. TFA	0 eq. TFA	0.5 eq. TFA	1 eq. TFA
3.20	3.31	3.50	156.5	155.1	153.6
3.27	3.39	3.63	54.63	52.76	51.95
3.70	3.77	3.89	52.74	52.30	50.98
---	8.11	8.93	46.29	45.33	44.58

Preparation and Further Studies of Derivatives of 2,3,5,6,8,9-Hexahydrodiimidazo[1,2-a:2',1'-c]pyrazine (16).

16 can be used as a nucleophilic species to prepare amidinium salts. As can be seen in Scheme 1.46, alkylation of **16** with benzyl bromide in toluene at room temperature for 3

Scheme 1.46

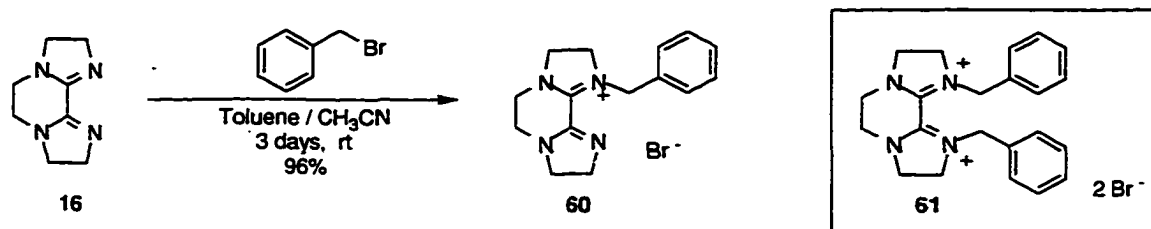

days cleanly afforded amidinium salt **60** in 96%. Changing the reaction conditions such that excess benzyl bromide in refluxing CH₃CN was used did not afford the bisalkylated salt **62**. NMR spectra showed that **60** was the major product. The other resonances observed in the NMR spectrum were complex and were most likely a result of a complicated mixture. This mixture could result from the presence of adventitious water in the reaction mixture which could give rise to many different hydrolysis products. There was no conclusive NMR evidence for the formation of **61** and therefore these data suggest that the second alkylation was not favorable. Benzylation of **60** to afford **61** would be expected to be a slow reaction as a result of the steric bulk provided by presence of the first benzyl group and the positive charge on the adjacent amidinium moiety.

DIBALH reduction of **60** for seven days gave a mixture of three products which were not separated but identified by NMR. As shown in Scheme 1.47, the NMR evidence was consistent with aminal **62** and two isomeric amines, **63** and **64** as the products of the reduction of **61**. Surprisingly, even after extended reaction times, **62** was the major product of this reaction. The other two products, observed in a roughly 1:1 ratio, could arise from cleavage of the aminal moiety by further reaction of **62** with DIBALH. It would

Scheme 1.47

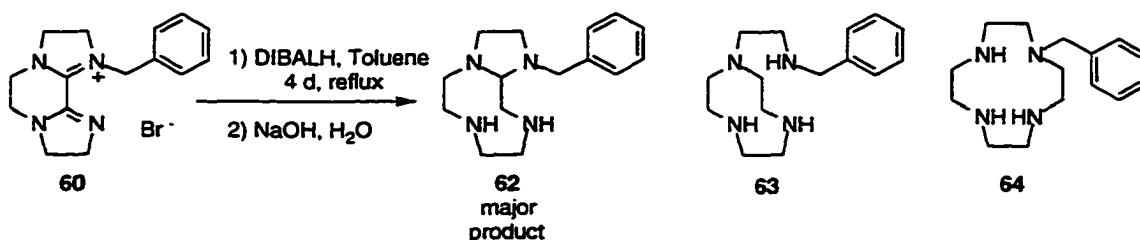

have been fortuitous to have obtained only one of the 2 isomeric amine products (**63** or **64**) but no control of the regiochemistry in the reduction of **62** was observed.

Similar results were obtained in the hydrolysis of **60**, whereby the regiochemical control over the hydrolysis at the amidinium carbon was lost. An NMR experiment was performed by dissolving **60** in D₂O. The NMR data obtained were consistent with a mixture of **65** and **66**. The results of this experiment are shown in Scheme 1.48.

We hypothesized that the mixture of polyamine isomers observed in the DIBALH reduction of amidinium salt **60** might possibly be biased by changing the group which is introduced in the alkylation step. The reduction mechanism is illustrated in Scheme 1.49.

Scheme 1.48

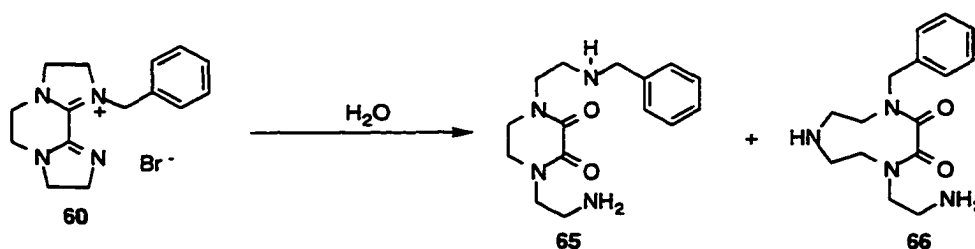

Scheme 1.49

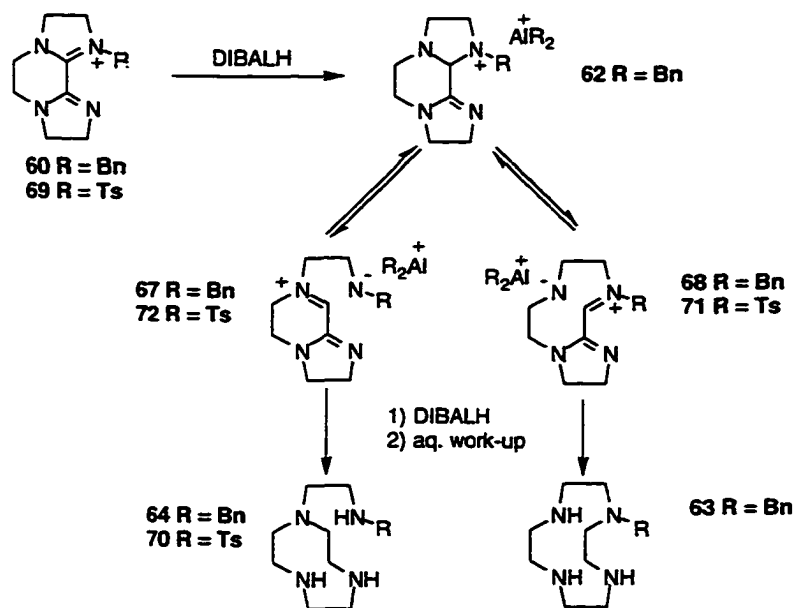

The isomeric products **63** and **64** result from the reduction of **62** to **67** and **62** to **68**. We hypothesized that the DIBALH reduction could be biased to favor either **67** or **68** by changing the group added in the alkylation reaction of **16**. Reaction of **16** with tosyl chloride is expected to afford amidinium salt **69** (Scheme 1.49). The tosyl group should bias the reduction of **69** to favor the 9-membered ring product (**70**) because of the stability of the tosyl amide intermediate (**71**) over the secondary amide intermediate (**72**). Reaction of tosyl chloride with **16** in toluene at room temperature gave a precipitate which was insoluble in all common NMR solvents except DMSO- d_6 . Unfortunately, this experiment has inherent ambiguity in that the DMSO- d_6 was contaminated with trace water. NMR data were consistent with **73**. Therefore, the hydrolysis of the desired product **69** to the

Scheme 1.50

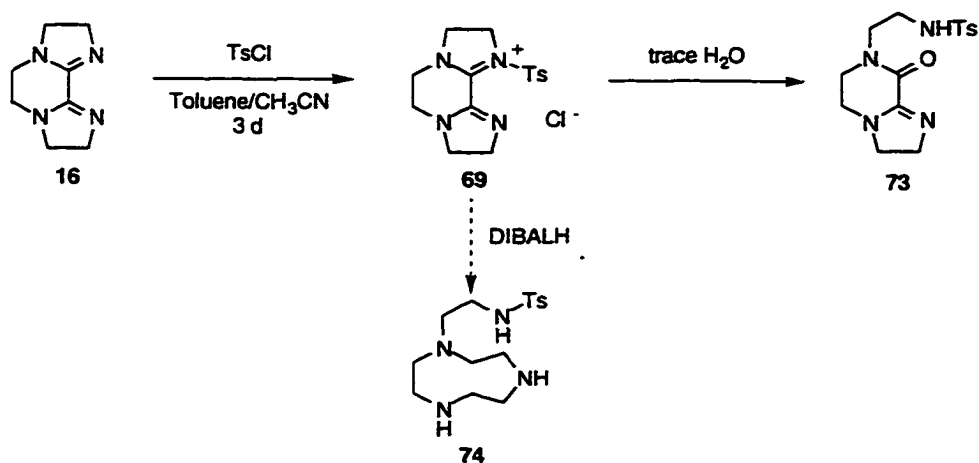

mono-amide/mono-amidine **73** may be taking place in the reaction or in the NMR tube from the water-contaminated solvent. This hypothesis is illustrated in Scheme 1.50. If the hydrolysis is taking place in the NMR tube then the amidinium salt is the species with poor solubility characteristics, which may be problematic. If the hydrolysis is taking place in the reaction then little is known about the amidinium salt at this juncture. The one essential piece of data that was obtained from this experiment is the fact that hydrolysis of **69** gave only one product (**73**) and not a mixture of isomers. This shows great promise that the DIBALH reduction will also proceed regioselectively to afford **74**. If **69** cannot be isolated it is likely that **73** would also undergo DIBALH reduction to afford **74**.

Experiments were also performed aimed at preparing tetraacyclic bisamidinium adducts of bisamidines. An example of this chemistry is shown in Scheme 1.51. Species such as **75** would also be interesting as precursors for tetraazacycloalkanes. Dications such as **75** are known compounds and their chemistry has been studied.⁹³ Reduction of

Scheme 1.51

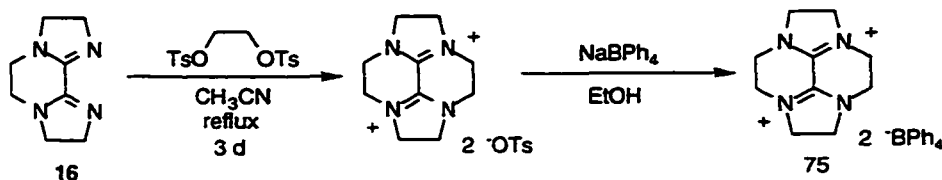

75 would be expected to give rise to interesting substrates for further chemistry. Reaction of **16** with 1,2-bis[*p*-toluenesulfonyloxy]ethane in CH₃CN at reflux did show promising results. Treatment of the crude reaction mixture with a saturated ethanolic solution of NaBPh₄ precipitated a white solid. NMR analysis of this solid was consistent with previously reported spectra for **75**.⁹³

Diels-Alder Chemistry of Vicinal Bisamidines

The tricyclic vicinal bisamidinium structure forces the diene portion of the molecule to be held in a *s-cis* conformation. Therefore these bisamidines may be suitable dienes for Diels-Alder chemistry. However, there are very few examples in the literature of a N=C-C=N diene system.⁹⁴ These novel bisamidines offer the opportunity to investigate this rare diene system. The Diels-Alder adducts which would be formed would be tetraaminoethylenes, highly electron rich species which are very labile.⁹⁵ A Diels-Alder reaction was attempted between **16** and *N*-phenylmaleimide (Scheme 1.52). It was desirable that the dienophile chosen have symmetry in order to minimize the number of regiochemical isomers which could be produced. *N*-Phenylmaleimide was chosen because

Scheme 1.52

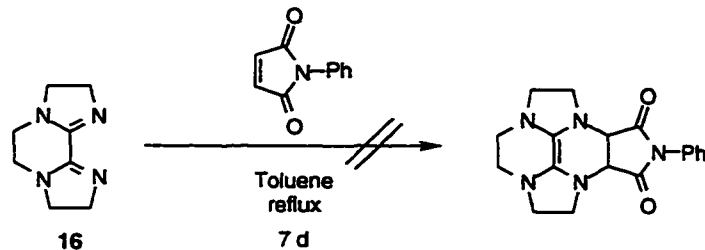

the imide would be hydrolytically more robust than maleic anhydride while retaining good reactivity as a dienophile.⁹⁶ Furthermore, the phenyl group provides an extra NMR handle to aid in the elucidation of the identity of the reaction products. The reaction was run in toluene for 7 days. The reaction mixture did change color to give a slightly orange solid following rotary evaporation. Unfortunately, no reaction was observed and starting material was observed by NMR analysis. Other dienophiles or higher boiling solvents have not been investigated.

CHAPTER II

SYNTHESIS OF CROSS-BRIDGED CYCLAM DERIVATIVES

I. INTRODUCTION

The many applications which have been developed for polyazacycloalkanes have been a direct result of the variety of structurally diverse polyazacycloalkane derivatives which have been prepared. In fact, polyazacycloalkanes are a small subset of ligands which are generally referred to as polyamine macrocycles. A polyamine macrocycle is often designed to be selective for a given cation by a series of structural modifications of a parent structure. These modifications have become essential tools in the rational design of ligands for specialized applications.

A modification which often affects the metal complexing properties of a polyamine macrocycle is restriction of the conformational flexibility of the molecule. One approach to restrict the conformational flexibility of a cyclic structure is to link or "bridge" parts of the ring together. This bridging is often accomplished by the functionalization of adjacent or nonadjacent nitrogen atoms of a polyamine macrocycle.

The first synthesis of a bridged derivative of cyclam (**1**) was reported by Wainwright, who prepared **81a** and **81b** by the reaction of 1,2-dichloroethane with cyclam.⁹⁷ The two nitrogen atoms located *adjacent* to each other in the ring system were

Scheme 2.1

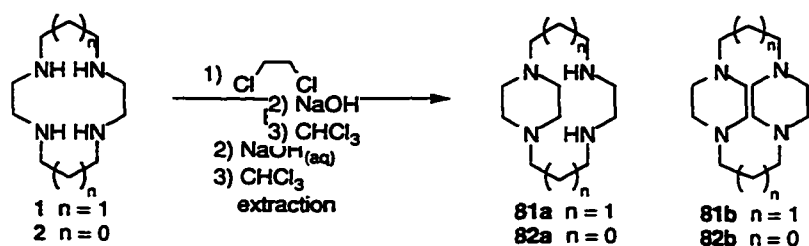

bridged in this reaction. This chemistry is shown in Scheme 2.1. Wainwright later expanded the series of “structurally-reinforced” macrocycles and prepared the cyclen derivatives **82a** and **82b**.⁹⁸ **82a** displayed different coordination chemistry than what was reported for cyclen. For example, the Ni^{2+} complex of **82a** had square planar geometry and the ligand was “*trans*” coordinated⁹⁸ instead of “*cis*” coordination as typically observed for Ni^{2+} complexes of cyclen.^{99,100}

Alternatively, it is also possible to bridge a nonadjacent pair of nitrogen atoms of cyclam (**1**). While synthetically more challenging, bridging of nonadjacent nitrogen atoms of cyclam was accomplished by Weisman and Wong in 1990.¹⁰¹ This “cross-bridged” cyclam is a bicyclic tetraamine which can adopt low energy conformations having all four nitrogen lone pairs convergent upon a cleft (Scheme 2.2). It was shown by Weisman and

Scheme 2.2

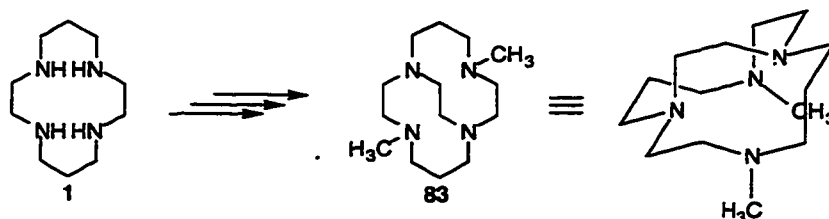

Wong that **83** was strongly basic and formed strong complexes with Li^+ . The synthesis of cross-bridged tetraamine ligands will be discussed in the following background section.

Another approach for the preparation of cross-bridged polyamine macrocycles was reported by Micheloni and coworkers.¹⁰² In this synthesis a selectively protected tetraamine is required as shown in Scheme 2.3. The secondary amino nitrogens react with the acid chloride moieties to install the cross-bridge. Upon reduction, a cross-bridged cyclen (**84**) is obtained. This approach is much less general than the method of Weisman and Wong. Furthermore, preparing the starting material is a multi-step process and the overall reaction sequence does not afford high yields of cross-bridged products.

Scheme 2.3

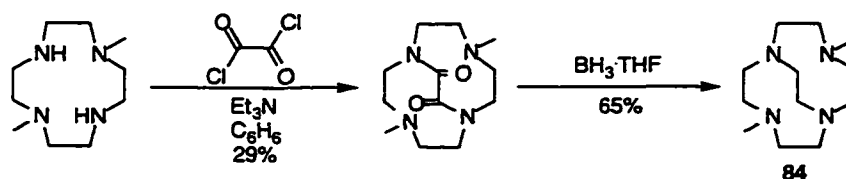

This chapter will discuss the synthesis of derivatives of cross-bridged cyclam. Many cross-bridged tetraamines have already been prepared.¹⁰³ These derivatives were prepared using the general method reported by Weisman, Wong and coworkers for the preparation of the parent diamino cross-bridged tetraamines.¹⁰⁴ This general method and some cross-bridged cyclam derivatives reported by Hill will be reviewed in the following presentation of the preparation of new derivatives of cross-bridged cyclams.

II. BACKGROUND

Synthesis of Cross-bridged Cyclam by Reductive Ring Expansion of Tetracyclic

Bisaminals.

Weisman and Wong reported the first cyclam derivative having nonadjacent nitrogens bridged by an ethanediyl (CH_2CH_2) unit.¹⁰¹ The rational synthesis of *N,N'*-dimethyl-1,4,8,11-tetraazabicyclo[6.6.2]hexadecane (**83**) from cyclam was reported. This synthetic sequence is shown in Scheme 2.4.

Scheme 2.4

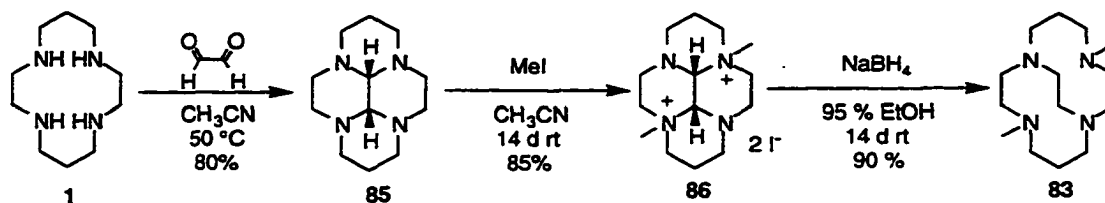

Earlier, the reaction of cyclam with aqueous glyoxal in CH_3CN had been reported by Weisman and coworkers to afford tetracyclic bisaminal (**85**) in 75% yield.¹⁰⁵ The stereochemistry of the ring fusion was found to be *cis*, allowing **85** to adopt a diamond-lattice conformation. As shown in Scheme 2.5, **85** exists as an enantiomeric pair of conformers which undergo an enantiomerization process interconverting **85** with **85'**. This process is slow on the ^{13}C NMR time scale at room temperature. Dynamic NMR experiments were carried out which resulted in broadening of the six ^{13}C NMR resonances (C_2 symmetry) observed for **85** as the probe temperature was increased. At 100°C the six resonances had coalesced to four (time averaged C_{2v} symmetry) and the activation barrier

Scheme 2.5

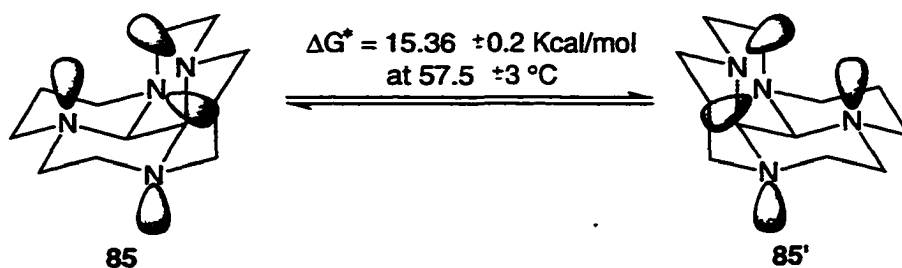

for this process was calculated to be $\Delta G^\ddagger = 15.36 \pm 0.2 \text{ kcal/mol}$ (at $57.5 \pm 3 \text{ }^\circ\text{C}$).¹⁰⁵

Regioselective methylation to afford **86** proceeds as a consequence of the conformation of **85**. Alkylation of one nitrogen shuts down the enantiomerization process because all four nitrogens must be inverted to complete this process. **85** has a concave face and a convex face which exposes only two nitrogen lone pairs for alkylation (Scheme 2.6).

Scheme 2.6

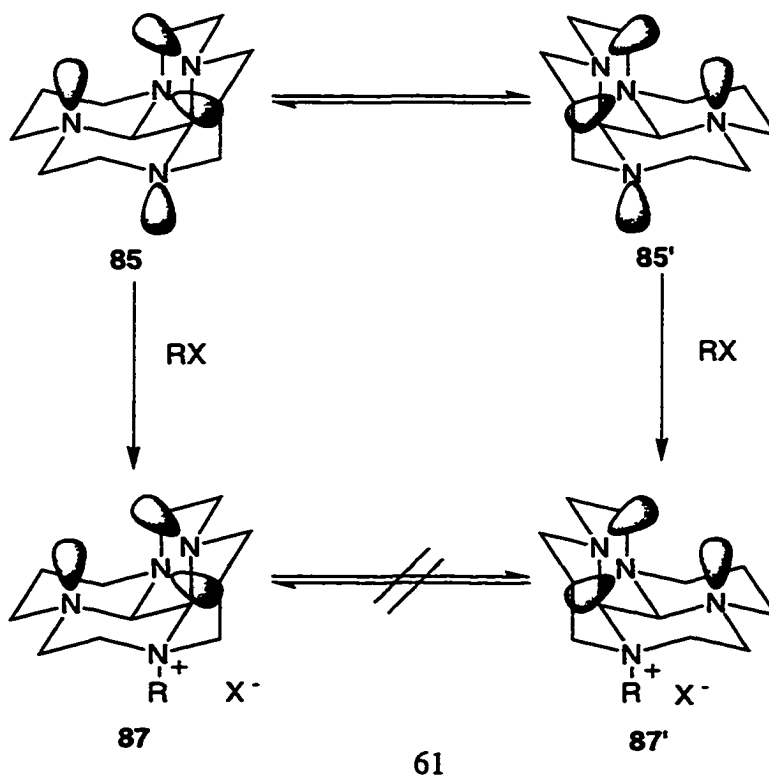

The two lone pairs available for alkylation belong to nonadjacent nitrogen atoms.

Therefore, once the first methylation takes place and enantiomerization is not possible (**87** and **87'**), only one lone pair remains accessible for alkylation resulting in regioselective methylation of **85**. The bis-quaternary bisaminal dimethiodide (**86**) was obtained as a white solid in 85% yield upon methylation of **85** in CH_3CN .

Reduction of **86** with excess NaBH_4 afforded **83** in 90% yield. Evidence later provided by Hines is consistent with this reaction proceeding through iminium ions which are reduced by borohydride.⁸⁹ This conclusion was drawn from the reduction of **86** with NaBD_4 . This chemistry is shown in Scheme 2.7. The reduction of **86** with NaBD_4 could afford a mixture of two *trans* diastereomers and two *cis* enantiomers (with respect to the deuterons of the $-\text{CHDCHD}-$ bridge). The results of the study showed that there was approximately a 60/40 *trans/cis* ratio of products but, more significantly, one *trans* diastereomer was formed almost exclusively over the other *trans* diastereomer. Therefore, this reaction is highly stereoselective for one of the *trans*

Scheme 2.7

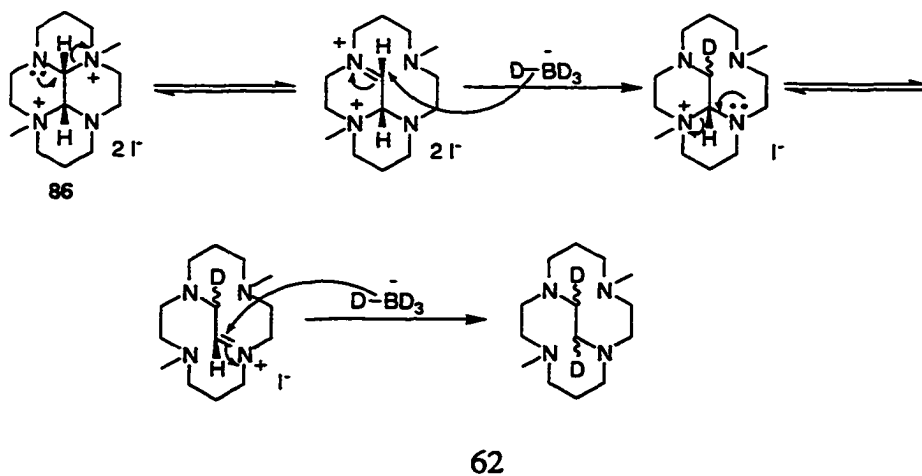

diastereomers. Formation of this diastereomer was most consistent with delivery of deuteride to an iminium ion from the least hindered approach of borodeuteride.

Cross-bridged cyclam **83** was found to be strongly basic. Weisman and coworkers's initial report on **83** calculated, by means of ^{13}C NMR experiments, the $\text{p}K_{\text{a}1}$ of $\mathbf{83}\cdot\text{H}^+$ in CD_3CN to be 24.9.¹⁰¹ The $\text{p}K_{\text{a}1}$ of $\mathbf{83}\cdot\text{H}^+$ in water was estimated to be higher than 13.5 and the $\text{p}K_{\text{a}2}$ for $\mathbf{83}\cdot 2\text{H}^+$ was estimated to be 10.8. In fact, **83** was shown to be much more basic than the analogous monocyclic isomer N,N',N'',N''' -tetramethyl-1,4,8,11-tetraazacyclotetradecane (tetramethylcyclam, **88**) and Alder's proton sponge (1,8-bis(dimethylamino)naphthalene, **89**).^{106,107} This is a crucial factor in the utility of cross-bridged cyclam derivatives for applications, particularly in aqueous media, which will be discussed in more detail later in this chapter.

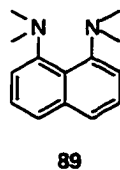
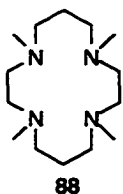

The synthetic strategy to prepare **83** was utilized to develop a general route to other cross-bridged tetraamine derivatives. Alkylation of bisaminal **85** with benzyl bromide was optimized by Hill.¹⁰³ **90** was prepared by Hill in 93% yield by the reaction of benzyl bromide and **85** in CH_3CN at room temperature for 14 days. The bis-quaternary bisaminal dibromide **90** was then reduced to N,N' -dibenzyl-1,4,8,11-tetraazabicyclo[6.6.2]hexadecane in 88% yield by reduction with excess NaBH_4 in 95% EtOH. Removal of the benzyl protecting groups was effected by hydrogenolysis to afford

Scheme 2.8

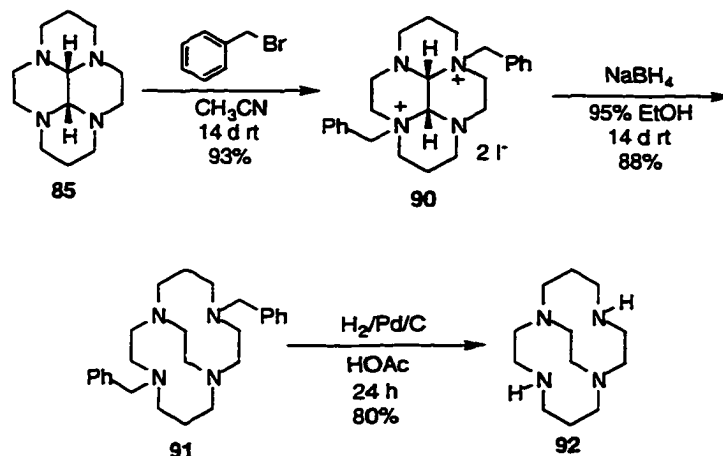

1,4,8,11-tetraazabicyclo[6.6.2]hexadecane (**92**) in 80% yield. This synthetic sequence, as shown in Scheme 2.8, was published in 1996.¹⁰⁴ In that publication the general method for the preparation of cross-bridged tetraamines was presented in addition to preliminary results on the metal complexation of these ligands with Cu^{2+} and Ni^{2+} .

Preparation of **92** has allowed for elaboration of the secondary amino nitrogens to prepare cross-bridged cyclams bearing pendant groups or “arms.” In theory, these arms are capable of influencing the complexation properties of the ligand. The chemistry required to perform the amino chain extension reactions to afford these “armed” derivatives often has been carried out on other polyaza macrocycles. Much of this chemistry has been reported in reviews.^{23,108} Some examples of functionalized cross-bridged cyclam derivatives have been reported by Hill.¹⁰³ The following section will present the syntheses of some of the compounds initially prepared by Hill as well as new cross-bridged cyclam derivatives.

III. RESULTS AND DISCUSSION

Synthesis of Amide Armed Derivatives of Cross-Bridged Cyclam.

In many cases the methodology for attachment of a specific pendant arm to a cross-bridged cyclam has been established for a polyaza macrocycle. Such was the case for the attachment of the acetamido arm to **92**. Tsukube has reported the reaction of *N,N'*-diethylchloroacetamide with cyclam (**1**) to afford **93**.^{109,110} Parker and coworkers also prepared the analogous cyclen derivative **94** by the reaction of *N,N'*-diethylbromoacetamide.¹¹¹ These two reactions are shown in Scheme 2.9.

Scheme 2.9

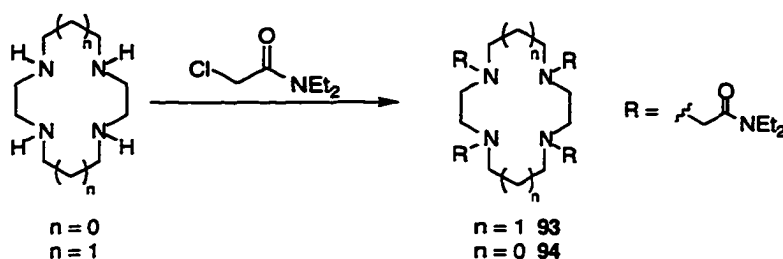

This methodology was applied to the preparation of **95**. *N,N'*-Diethylchloroacetamide was reacted with **92** in the presence of excess K₂CO₃ and catalytic KI (Scheme 2.10). An acidic extraction was performed to remove excess *N,N'*-diethylchloroacetamide prior to the basic extraction required to isolate the product. **95** was obtained in 93% yield as a waxy solid. This ligand was envisioned to be a better ligand for metal cations than the dimethyl derivative **83** as a result of the two additional ligating groups which are now available. The complexation studies performed with this ligand will

Scheme 2.10

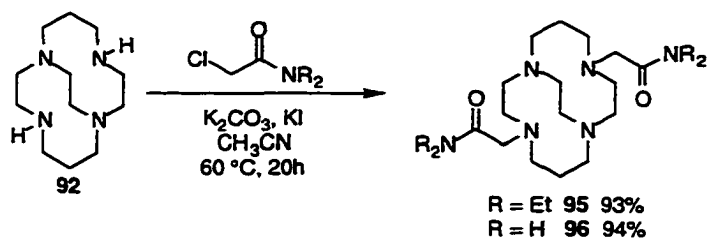

be presented in Chapter 3.

Reaction of 2-chloroacetamide with **92** in CH_3CN in the presence of excess K_2CO_3 and catalytic KI analogously provided **96** (Scheme 2.10). The product was isolated as a white waxy solid in 94% yield. Two NH amide protons were observed in the room temperature ^1H NMR spectrum (5.74, 7.15 ppm). This ligand should also form good complexes with metal cations as a result of the six ligating groups available. Furthermore, the acidity of the amide protons allow for the possibility of neutral complexes with divalent cations to be formed following deprotonation of the amide moieties.

Conjugate addition of amines into an α,β -unsaturated carbonyl or nitrile substrate has been well documented.¹¹² In fact, Hill has used this chemistry in the preparation of **97**.¹⁰³ As shown in Scheme 2.11, the reaction of **92** in neat acrylonitrile afforded essentially a quantitative yield of

Scheme 2.11

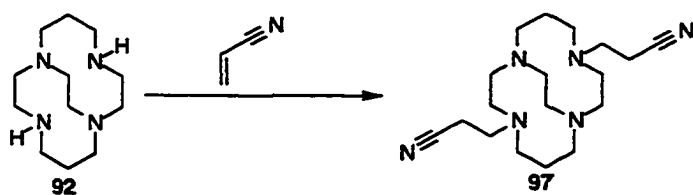

Scheme 2.12

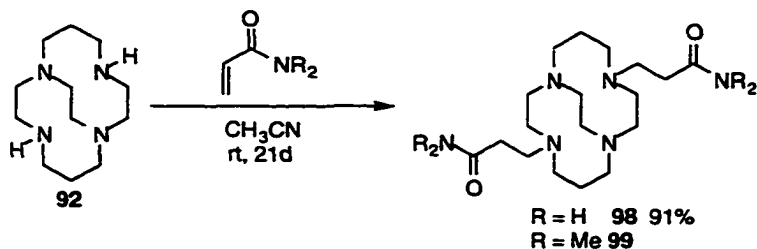

97. One would predict that the reaction would also follow analogously when acrylamide was substituted as the Michael acceptor. Reaction of acrylamide with **92** in CH₃CN at room temperature afforded **98** in 91% yield as a waxy white solid (Scheme 2.12).

Although never attempted, it is reasonable to assume that the reaction of **92** with *N,N'*-dimethylacetamide would also be successful in preparing **99**, a tertiary amide analog of **98**.

Attempted Synthesis of Hexaaza-Cross-Bridged Cyclam Derivatives.

Attempts were made to reduce bisamide-armed cross-bridged cyclam **96** to bis(2-aminoethyl)-cross-bridged cyclam **100**. Reduction was attempted with BH₃•THF and NMR data was consistent with product formation along with a complicated mixture (Scheme 2.13). Unfortunately, conditions were not found which provided **100** cleanly. Following BH₃•THF reduction of amides, a complex is formed between boron and the amine product(s). The workup of these reactions requires an acidic hydrolysis of the B-N bonds of the complex to liberate the free amine. It is likely that reduction was successful but the difficulties in obtaining **100** arose from incomplete hydrolysis of the B-N bonds of

Scheme 2.13

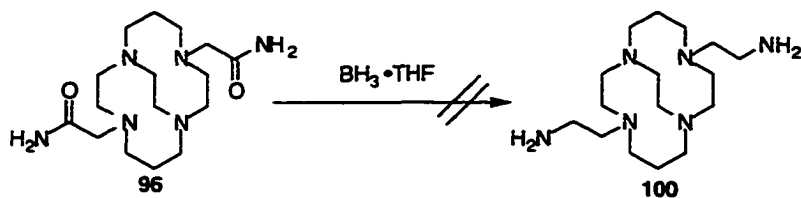

complexes which boron formed with cross-bridged **100**.

Hill attempted the reduction of the nitrile-armed derivative **97** by hydrogenation over Raney Ni.¹⁰³ He discovered that an elimination reaction was competing with the reduction process. This resulted in dealkylation of **97** to afford mono-armed pentaamine **101** in addition to hexaamine **102** (Scheme 2.14). However, there are other published

Scheme 2.14

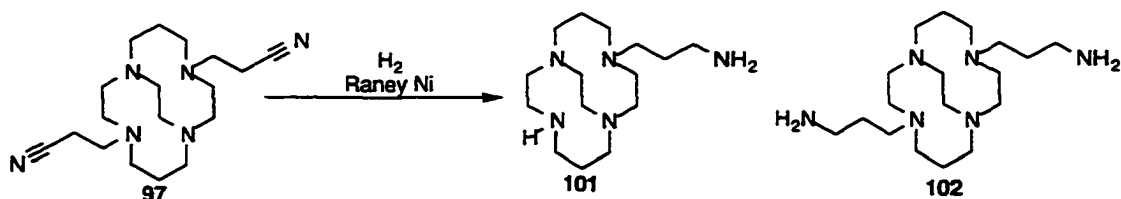

methods for the reduction of nitrile moiety primary amines which may not favor this elimination reaction. One possibility which was investigated was reduction of **97** with $\text{BH}_3 \cdot \text{THF}$ (Scheme 2.15). Unfortunately, these conditions did not provide **102**. It is

Scheme 2.15

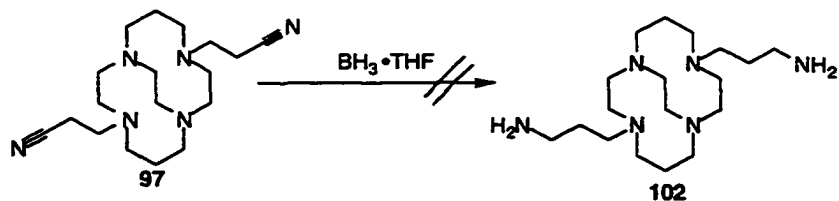

Scheme 2.16

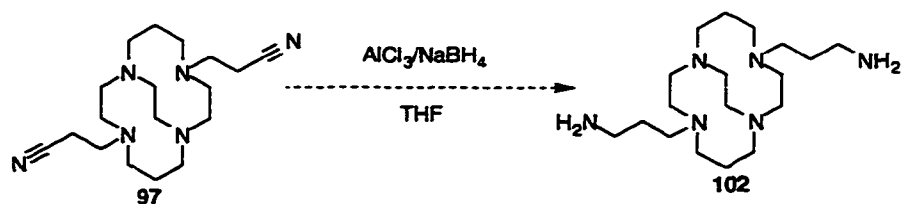

likely that these reaction conditions also afforded a boron-cross-bridge complex with robust B-N bonds towards hydrolysis. Another method which should be investigated is of the nitrile moieties using the conditions reported by Brown.⁷⁴ AlCl₃/NaBH₄ in THF were found to be effective conditions for the reduction of 32 to 31 in the preparation of benzocyclam (34) discussed in Chapter 1. This idea is shown in Scheme 2.16. Under these conditions, robust boron-cross-bridged complexes are avoided. It remains to be determined, however, if this chemistry will also facilitate elimination of the arm or provide a clean method for reduction of the nitrile.

Another approach toward preparation of hexaaza cross-bridged cyclam was attempted using tosylaziridine (103). Murase and coworkers¹¹³ and Kida¹¹⁴ have reported the reaction of tosylaziridine with cyclam to afford 104 and the further detosylation to the octaaza cyclam derivative 105 (Scheme 2.17). Tosylaziridine was

Scheme 2.17

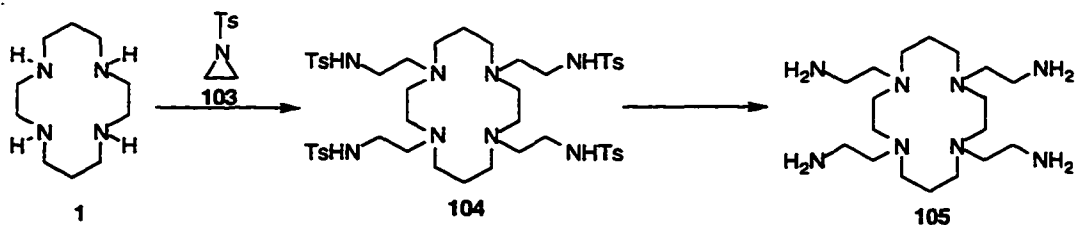

Scheme 2.18

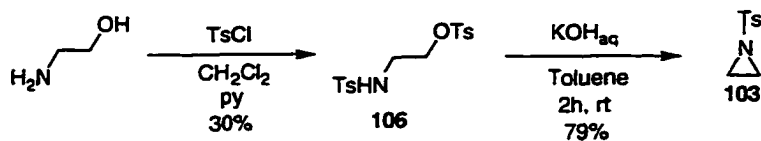

prepared in our laboratories by the method of Lehn.¹¹⁵ Treatment of ethanolamine with tosyl chloride afforded the tosylaziridine precursor **106** which was converted to **103** upon treatment with base in 79% yield (Scheme 2.18). Reaction of **103** with **92** in CH₃CN afforded a powder. ¹³C NMR analysis of the powder supported formation of **107** (Scheme 2.19). It was difficult to estimate the relative purity of **107**. The resonances for the cross-bridge carbons are all dynamically broadened but it is likely that at least 80% of this sample is **107**. Unfortunately, recrystallization methods were not found which gave purified **107**.

Scheme 2.19

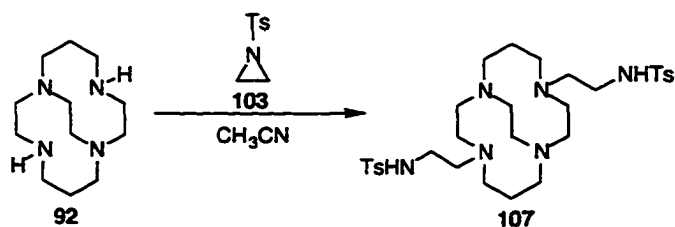

Attempts to Alkylate **85** with Bromobutane and 1-[(*p*-tolylsulfonyl)oxy]-2-methoxyethane.

It would be desirable to improve the synthetic methodology to prepare derivatives of cross-bridged cyclam. More specifically, it would be convenient to derivatize early in the synthetic sequence. This would reduce the number of synthetic steps and potentially

increase the yield for desired products. The methodology employed incorporates functionality into the cross-bridged ligand after the installation of the cross-bridge. As shown in Scheme 2.20, it currently takes 4 steps to prepare **92** from commercially available cyclam (**1**). **92** is the key precursor for the various functionalized cross-bridged cyclam derivatives that have been prepared. We believed that if alkylation of **85** was a facile reaction, and the appended functionality could survive the NaBH_4 reduction, the number of steps in the synthetic method could be decreased for some of our synthetic targets. **85** would then be the key precursor from which many cross-bridged cyclam derivatives might be prepared.

To date, the only alkylating agents which have been used do not have protons located β to the carbon to be alkylated. This is significant because there is no possibility for an elimination reaction competing with the $\text{S}_{\text{N}}2$ reaction. A study was devised to determine if the elimination reaction which would be possible if there were protons β to the halide would cause significant difficulties in the alkylation reaction. Bromobutane (**108**) or

Scheme 2.20

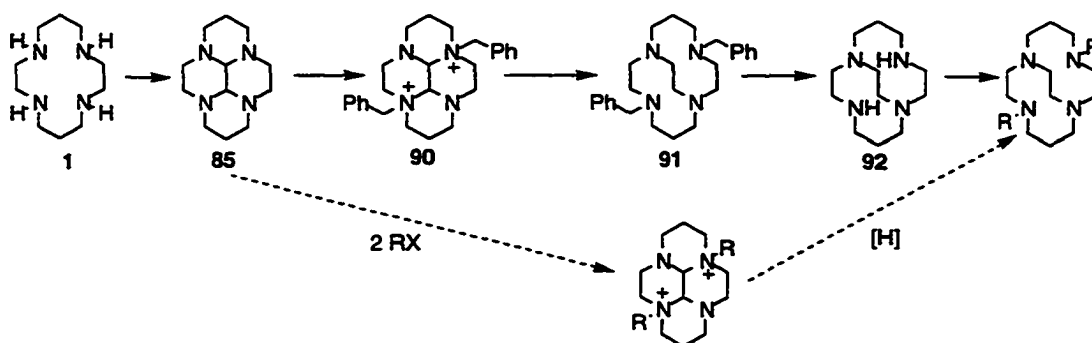
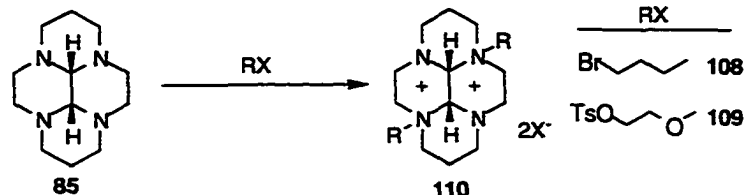

Table 2.1: Reaction Conditions and Results for the Reaction of 85 with Bromobutane (108) and [(*p*-Tolylsulfonyl)oxy]-2-methoxyethane (109)



RX	eq RX	Rxn. Temp.	Solvent (mL)	Time (days)	KI (eq)	Products	
1	108	4	ambient	CH ₃ CN (5)	8	----	mono/sm
2	108	8	ambient	CH ₃ CN (2)	2	----	mono/sm
3	108	8	ambient	CH ₃ CN (2)	5	8	elimination
4	108	8	ambient	DMF (2)	2	---	mono/sm
5	108	8	50 °C	CH ₃ CN (2)	1	8	elimination
6	109	8	ambient	CH ₃ CN (2)	8	----	elimination

mono: monoalkylated product s.m.: starting material

1-[(*p*-tolylsulfonyl)oxy]-2-methoxyethane (**109**) was introduced to **85** in CH₃CN under various conditions in the hope of preparing the bis-quaternary bisaminine **110**. A summary of the reaction conditions which were investigated is given in Table 2.1. In no case was **110** observed by NMR. The reaction either resulted in monoalkylation of **85**, elimination of **108** or **109**, or no reaction. At this juncture it was concluded that it was generally necessary to use alkylating agents which were unable to undergo an elimination reaction for the preparation of bis-quaternary derivatives of bisaminine **85**.

Attempted Monoalkylation of 1,4,8,11-Tetraazabicyclo[6.6.2]hexadecane (112).

The methodology to prepare monofunctionalized derivatives of **92** was reported by Hill. This approach involved monobenylation of **85** to afford **111** as shown in Scheme 2.21. Methylation of **111** afforded **112**, which upon reduction with the standard NaBH_4 conditions, gave **113**. Hydrogenolysis of **113** afforded the monomethylated cross-bridged cyclam derivative **114**. However, we required a method to prepare monobenzylated derivative **115** for other applications. Furthermore, monobenzylated derivative **115** would allow for functionalization of the two secondary amino nitrogens of **92** with different pendant arms. We predicted that benzylated **115** could be prepared by simply controlling the stoichiometry of the reagents without an added base. Without the

Scheme 2.21

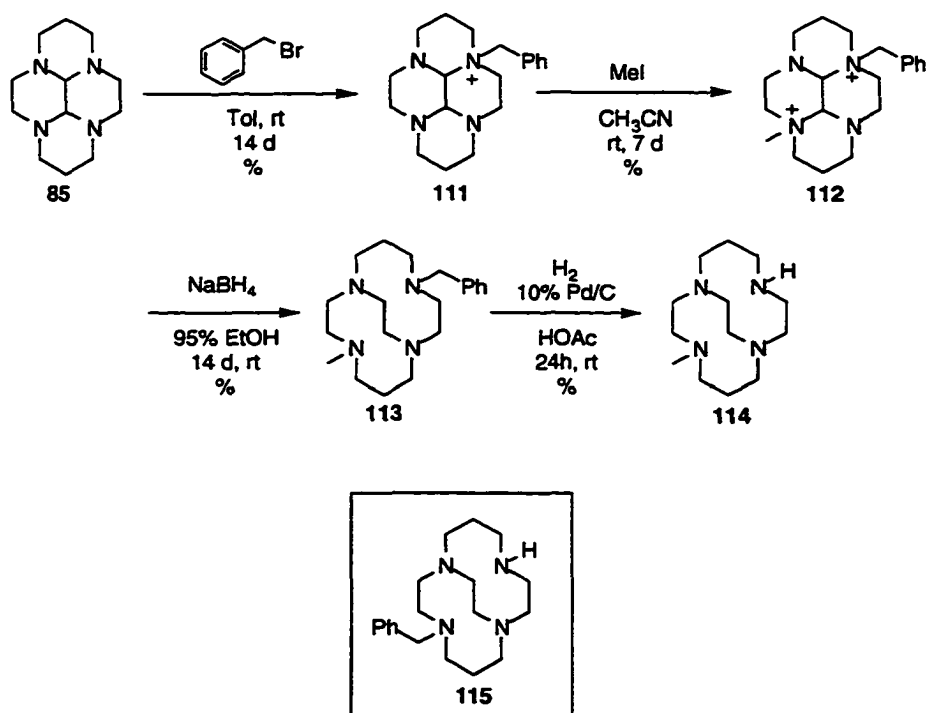

base present, following the first alkylation, the product would likely be protonated. We believed that this would drastically reduce the susceptibility of this species to undergo further S_N2 reaction and afford **115**.

Benzyl bromide was reacted with **92** in a 1:1 stoichiometric ratio in CH_3CN at reflux for 16 hours. The NMR analysis of the reaction mixture following base extraction was consistent with a mixture of three compounds. As shown in Scheme 2.22, the desired product (**115**) was formed in addition to the dibenzylated **91** and unreacted **92**. We then altered the reaction conditions such that further benzylation of **115** would not be favored. **92** was reacted with benzyl bromide in a 1:1 ratio in toluene at room temperature. We believed that these conditions might bring about the precipitation of **115**•HBr. If this were to occur, further benzylation would not be possible and **115** would be isolable following basic extraction of the precipitate. After four days a white precipitate had formed which was collected and evaluated by NMR following a basic extraction. Unfortunately, NMR analysis identified **91** as the product of this reaction. To date, no conditions have been found that result in the preparation and isolation of **115**.

Scheme 2.22

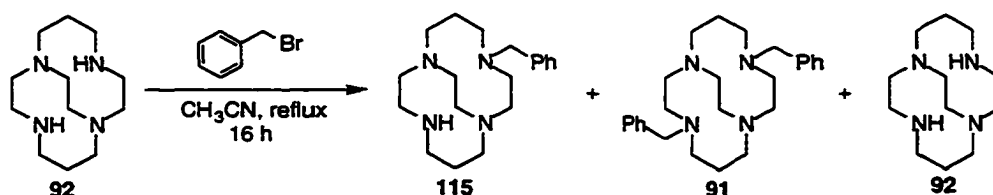

Alkylation of 1,4,8,11-Tetraazabicyclo[6.6.2]hexadecane (92) with 1-[(*p*-tolylsulfonyl)oxy]-2-methoxyethane (109).

We believed that S_N2 alkylation of 92 with simple alkyl halides may not proceed well. The strong basicity of cross-bridged cyclam might promote deprotonation of an alkyl halide facilitating the elimination reaction competing with the S_N2 reaction. The alkylating agent used in this study was 1-[(*p*-tolylsulfonyl)oxy]-2-methoxyethane (109). 109 was chosen because the cross-bridged cyclam derivative which would be formed (116) had been previously prepared by Hill by an independent method.¹⁰³ Reaction of 92 with 109 in CH₃CN with K₂CO₃ at 60 °C for 21 hours afforded 116 in 40% yield (Scheme 2.23). This reaction was run on a small scale (25 mg) and the yield was not optimized. However, this methodology can now be applied to other alkylating agents possessing β protons and does have significant potential utility to afford a wide variety of new cross-bridged cyclam derivatives.

Scheme 2.23

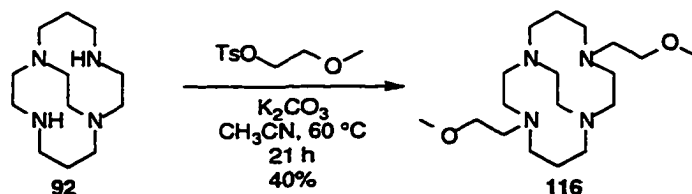

Cross-Bridged Cyclam Derivatives with Decreased Basicity.

As mentioned previously, cross-bridged cyclam derivatives are strongly basic. This unusually strong basicity is attributed to the design of the macrocyclic structure which has all four nitrogen lone pairs convergent upon a cleft. This structural feature leads to strong complexation of small metal cations and therefore also leads to good complexation of protons. This unusual basicity can be attributed to three factors.

The first factor involves the relative energies of the conformations of the bicyclic rings of cross-bridged tetraamines. Molecular mechanics calculations on **83** and **91** performed by Weisman suggest that the low energy conformations for these two species all have convergent nitrogen lone pairs.¹¹⁶ Therefore, since convergent conformations are low in energy, the majority of the populated conformations in solution are convergent.

These convergent conformations, however, do suffer from poor solvation because the lone pairs are not accessible to the surrounding media. The introduction of a proton source effectively solvates the tetraamine by protonating the lone pair located inside the cavity. This idea can be explained in a qualitative manner by the structure shown in

Scheme 2.24

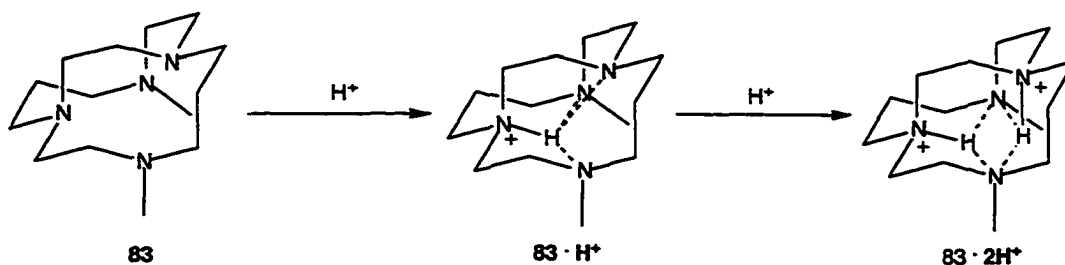

Scheme 2.24. A proposed low energy conformation of **83** is shown. This proposed conformation has the two 10-membered rings of **83** in a [2323] conformation. Protonation of **83** with one equivalent of acid leads to **83•H⁺**. The proton fits into the cavity of **83** taking a position such that it is also hydrogen bonded to the three other nitrogen lone pairs (trifurcated). However, an x-ray crystal structure obtained for the dibenzyl analogue (**91•H⁺**)¹¹⁶ does not show the tetraamine in a [2323]/[2323] conformation. The conformation of the tetraamine is [37]/[37] but all four nitrogen lone pairs are still convergent towards the center of the cavity. Addition of another equivalent of acid places another proton in the cavity of a cross-bridged cyclam. The proposed conformation for **83•2H⁺** has two protons inside the cavity hydrogen bonded to two nitrogen lone pairs (bifurcated) having the two 10-membered rings in a [2323]/[2323] conformation. An x-ray crystal structure of **83•2H⁺** confirms that, in the solid state, the conformation of the two 10-membered rings are [2323/2323].¹⁰¹

Therefore, it is energetically unfavorable to remove the proton from the inside of the cavity. The “proton-solvation” relieves the destabilizing interaction of the convergent lone pairs which is the second factor leading to the unusually high basicity for cross-bridged tetraamines. Furthermore, the proton on the inside of the cavity has very strong hydrogen bonds which must be disrupted in order to deprotonate the tetraamine. All three of these factors combined are responsible for the unusually high pK_{a1} for **83•H⁺** and pK_{a2} for **83•2H⁺**.

Unfortunately, this strong basicity is problematic for applications utilizing cross-

bridged cyclam derivatives as ligands carried out in protic media. Therefore, it would be desirable to develop other derivatives which are less basic while retaining the complexation properties of the previously studied cross-bridged analogues. A number of approaches have been proposed to accomplish this goal.¹¹⁷ Preliminary work on two of these approaches has been initiated. These two approaches include: 1) attachment of aryl arms to **92**; 2) benzo-annulation to NCH₂CH₂N units of **91**. Both of these approaches are aimed at decreasing the basicity of two of the amino nitrogen lone pairs by the presence of the adjacent aromatic ring.

Preparation of Aryl Armed Cross-Bridged Cyclam Derivatives.

The use of nitrogen as a nucleophile in nucleophilic aromatic substitution (NAS) reactions has been well studied.^{118,119} Unfortunately, using a secondary amino nitrogen does require a highly reactive electrophile to effect the NAS reaction. The best group for activating an aromatic ring to accept a nucleophile in an NAS reaction is the nitro group. Arming **92** with a nitroaryl group might also provide the new cross-bridged cyclam derivative with an added benefit in addition to the decreased basicity. The derivative would absorb light in the UV-Vis region of the spectrum. Additionally, the wavelength of light which is absorbed would likely change upon complexation. Ligands which have these properties are called chromogenic hosts¹²⁰⁻¹²² and allow for monitoring of complexation.

2,4-Dinitrofluorobenzene (**117**) has been extensively used in the labeling of amino

Scheme 2.25

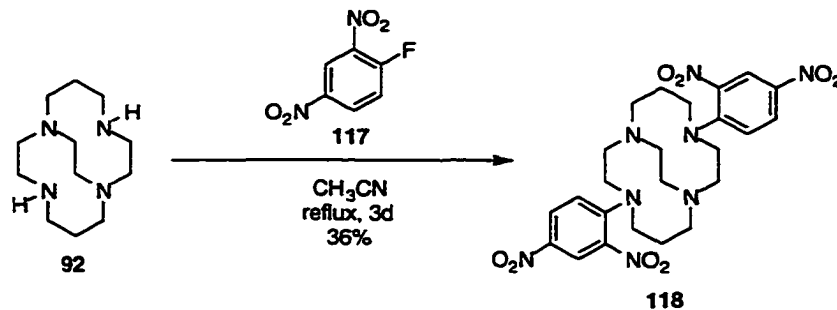

acids.¹²³ Addition of **117** to a solution of **92** in CH_3CN , with K_2CO_3 as the base, resulted in an immediate reaction (Scheme 2.25). The mixture was heated at reflux for three days and afforded 36% of an orange powder. NMR analysis of this powder was consistent with **118**. The powder was recrystallized from toluene to afford purified **118**. The powder had poor solubility in many organic solvents at room temperature (Et_2O , EtOH , CH_3CN , toluene) and was characterized by NMR, IR and low resolution MS.

119 was analogously prepared using *p*-bromonitrobenzene as the electrophilic species. The reaction of **92** with *p*-bromonitrobenzene in CH_3CN , with K_2CO_3 , as the base afforded the *p*-nitrophenyl armed cross-bridged cyclam derivative (**119**) (Scheme 2.26)

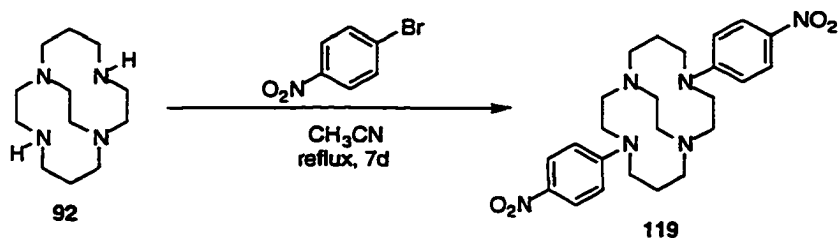

2.26). The reaction was not as facile as in the preparation of **118**, but after 7 days of heating, **119** was obtained. The crude product was purified by recrystallization from DMF. **119** also displayed poor solubility characteristics and was insoluble in many solvents (MeOH, EtOH, *i*prOH, CH₃CN, toluene, benzene, Et₂O). **119** has been characterized by NMR, IR and low resolution MS.

At this juncture it was determined that other aryl derivatives that had better solubility characteristics than the nitroaryl derivatives might be more useful. Unfortunately, the nitro group is the best substituent to activate an aromatic ring towards an NAS reaction. Other electron withdrawing groups which might lead to better solubility, such as CF₃ or F were discussed as possible alternatives to NO₂ but were never investigated. Alternatively, a Pd⁰-catalyzed coupling approach reported by Buchwald^{124,125} and Hartwig¹²⁶ was investigated.

The preparation of arylamines from an amine and a arylbromide under the catalysis of Pd₂(dba)₃ (**120**) and BINAP (**121**) has been reported.^{124,125,126} Buchwald has used this methodology to arylate optically active amines without loss of optical purity.¹²⁴ We believed that this chemistry would provide the tolyl derivative **122** using these conditions with racemic BINAP. This chemistry is shown in Scheme 2.27. The reaction gave a mixture of products. Conditions were not found which separated these components of the reaction mixture. NMR analysis was consistent with the formation of **122** as a minor product but the major product was monoarylated **123**.

Scheme 2.27

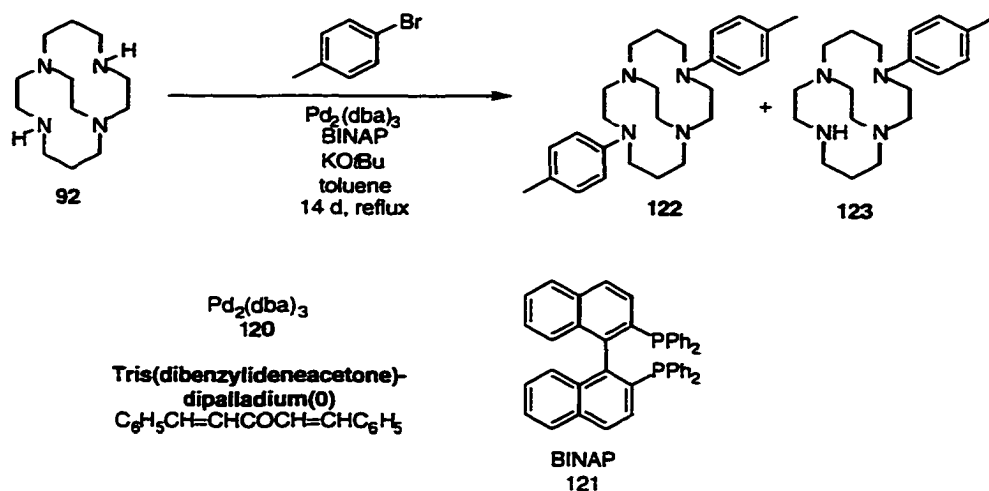

One other approach which was briefly investigated was the use of the amide anion of **92** as a nucleophile in a NAS reaction. Amide anions have been shown to be excellent nucleophiles in NAS reactions and often react readily with unactivated nucleophiles. Furthermore, the mechanism of these NAS reactions has been studied and is most

Scheme 2.28

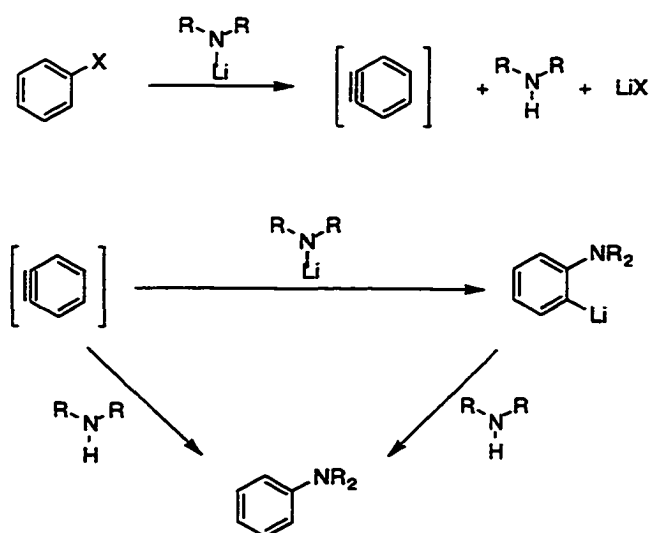

Scheme 2.29

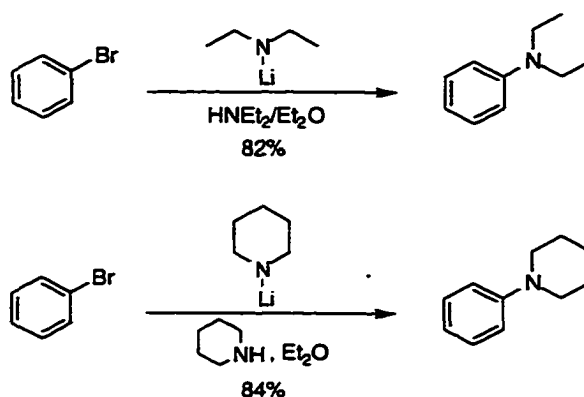

consistent with the generation of a benzyne intermediate.¹²⁷ The proposed pathway for arylamine formation from an alkali amide and an aryl halide is shown in Scheme 2.28. The only caveat to this reaction is that the regiochemistry cannot be controlled. Therefore, either unsubstituted or symmetrically substituted aryls must be used to reduce the number of isomeric products which could be formed. The reaction of an N-lithio secondary amine with bromobenzene in Et₂O has been reported. The reaction of N-lithiodiethylamine with bromobenzene in HNEt₂/Et₂O afforded an 82% yield of N,N-diethylaniline and N-lithiopyrrolidine with bromobenzene in pyrrolidine/Et₂O afforded an 84% yield of N-phenylpyrrolidine.¹²⁸ These reactions are shown in Scheme 2.29.

The addition of bromobenzene to a THF solution of **92** which had been previously treated with two equivalents of n-butyllithium gave an immediate color change from yellow to red. The mixture was stirred under N₂ at room temperature for 12 hours (Scheme 2.30). NMR analysis revealed that the reaction had produced a complex mixture. Attempts were made to try and separate components of this mixture by TLC. Unfortunately, conditions to

Scheme 2.30

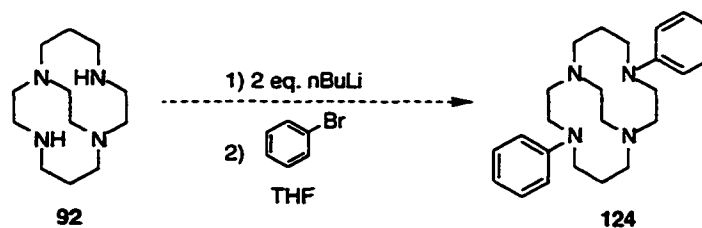

separate these compounds were not found. However, a reaction had taken place and it is unknown if modifications of the reaction conditions might provide 124 after purification.

Preparation of Benzocyclam Derivatives.

Benzocyclam (34) has been prepared using the regioselective reduction as described in Chapter 1. Bisaminal 125 was prepared in 89% yield by the condensation of aqueous glyoxal with benzocyclam in CH_3CN (Scheme 2.31).

As previously observed by Weisman et al. for 85,¹⁰⁵ NMR spectra for 125 displayed dynamic broadening in the ^1H and ^{13}C spectra at ambient probe temperature. The dynamic broadening is the result of the enantiomerization of *cis*-125, which is not

Scheme 2.31

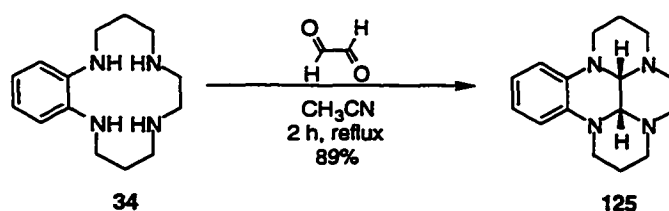

possible for the *trans* isomer. Using Dynamic NMR spectroscopy (DNMR) techniques, the ΔG^\ddagger for the enantiomerization process of **85** was reported by Weisman et al.¹⁰⁵ A similar approach was applied to investigate the dynamic broadening observed for **125**. The results of this study established conclusively the stereochemistry of the ring fusion and allowed for comparison of the estimated ΔG^\ddagger with that of **85**.

A complete line shape analysis was performed on $^{13}\text{C}\{^1\text{H}\}$ spectra of **125** at different probe temperatures. The enantiomerization process corresponds to a two-site mutual exchange process for pairs of carbon resonances. In this process, two nuclei in the same molecule (for this case) exchange environments. Because the process is an enantiomerization, the rate for the forward and reverse reactions are equivalent and the populations of the two species in exchange must also be equivalent. Spectra were acquired over a 100° temperature range (-75 - 25 °C). The ambient temperature spectrum (90.56 MHz) displayed dynamic broadening for some of the eight lines but those resonances were clearly in fast-intermediate exchange on the NMR time-scale (shown in Figure 2.2). Upon cooling the probe to -78 °C, the spectrum resolved into sixteen lines for these spectra of *cis*-**125** in slow-intermediate exchange. Table 2.1 lists the chemical shifts for *cis*-**125** at different temperatures. As determined from the slow-exchange limit spectrum, *cis*-**125** has overall C_1 symmetry whereby all ^{13}C nuclei are magnetically nonequivalent. At ambient temperatures, the enantiomerization process results in time-averaged C_s symmetry for *cis*-**125**.

The ambient temperature spectrum had only two broadened lines, one for a

Figure 2.1: ^{13}C NMR Spectrum of 125 at Ambient Probe Temperature.

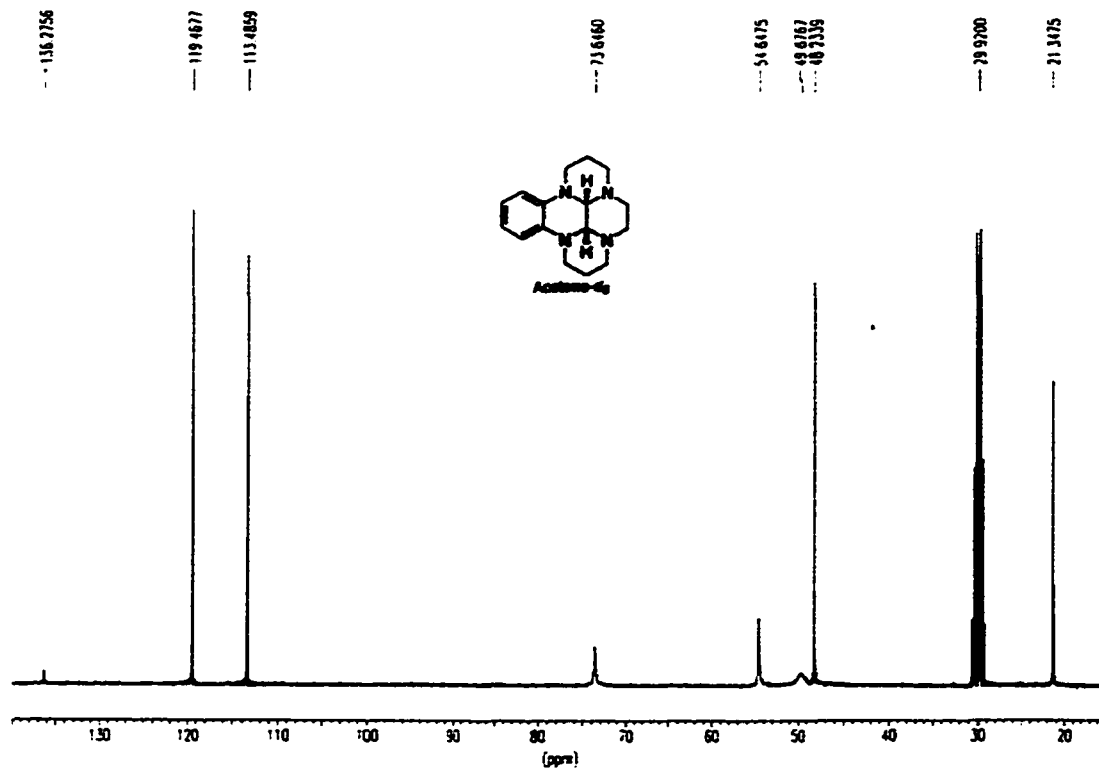
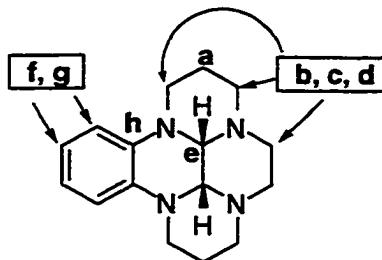

Table 2.2: ^{13}C NMR Chemical Shifts for 125 at Various Probe Temperatures



Temp °C	C_a	C_b	C_c	C_d	C_e	C_f	C_g	C_h
25	21.35	48.23	49.68	54.65 [‡]	73.65 [‡]	113.5	119.5	136.3
15	21.32	48.23 [‡]	∅	54.55 [‡]	73.66 [‡]	113.5	119.5	136.3 [‡]
1	21.29 [‡]	48.19 [‡]	∅	54.52 [‡]	73.46 [‡]	113.6	119.5	∅
-11	21.26	48.17 [‡]	∅	54.35 [‡]	∅	113.6	119.6	∅
-15	21.21 [‡]	48.19 [‡]	∅	∅	∅	113.6	119.6	∅
-34	20.59 [‡]	48.06 [‡]	44.19 [‡]	52.28 [‡]	70.91 [‡]	113.7 [‡]	119.6	∅
	21.85 [‡]		54.91 [‡]	56.68 [‡]	75.83 [‡]			
-43	20.57 [‡]	47.96 [‡]	44.18 [‡]	52.32 [‡]	70.89 [‡]	113.6 [‡]	119.6	134.9 [‡]
	21.86 [‡]		54.90 [‡]	56.57 [‡]	75.78 [‡]			113.9 [‡]
-50	20.56	47.93	44.16	52.26	70.89	114.0	119.6 [‡]	134.9 [‡]
	21.88		54.94	56.60	75.82			113.6
-73	20.56	47.89	44.10	52.29	70.81	113.7	119.7	135.0
	21.82		54.89	56.53	75.74			114.1

[‡] Dynamic broadening observed for this resonance

∅ Resonance broadened into the baseline and δ could not be determined

methylene adjacent to nitrogen ($C_{b, c \text{ or } d}$) and the methine (C_e). However, decreasing the temperature by only 10 ° made dramatic changes in the observed spectrum. One resonance (C_c) had broadened into the baseline such that it could not be detected. C_b and the ipso carbon (C_h) had also begun to broaden at 15 °C. At 1° C all but two aromatic resonances

displayed broadening, including the resonance for C_a which was used for the complete line shape analysis. When the probe temperature was decreased to $-15\text{ }^\circ\text{C}$, four resonances (C_a , C_d , C_e and C_h) were all broadened into the baseline. The spectrum for **125** at $-34\text{ }^\circ\text{C}$ showed that **125** was clearly in fast intermediate exchange because four resonances (C_a , C_c , C_d , C_e) had each coalesced into separate lines. The spectrum for $-43\text{ }^\circ\text{C}$ showed all but one resonance decoalesced into separate lines as the rate of enantiomerization of **125** neared the slow exchange limit. Very little change could be noticed in the $-50\text{ }^\circ\text{C}$ spectrum but when the probe temperature was lowered to $-73\text{ }^\circ\text{C}$, all resonances had coalesced into two distinct lines. The $-73\text{ }^\circ\text{C}$ spectrum was used as the slow exchange limit.

The DNMR spectra were simulated using the gNMR¹²⁹ program in order to obtain data for the rate of enantiomerization at different probe temperatures. The resonance at 21 ppm in the ambient probe temperature spectrum was used for the simulations. This resonance was chosen because it was isolated from the rest of the spectrum, having no overlapping peaks. The NMR spectra and the corresponding simulation are shown in Figure 2.2. Rate constants calculated from these simulations are presented in Table 2.3.

From these data, a free energy of activation can be calculated (ΔG^\ddagger) for this process can be calculated for a given temperature. The rearranged form of Eyring equation (Equation 2.1b) describes the free energy of activation as a function of $(\ln k/T)$ and $(1/T)$. Furthermore, as described in Equation 2.2, the free energy of activation is also related to ΔH^\ddagger and ΔS^\ddagger . These two equations can be used to derive Equation 2.3 which describes the relationship between $(\ln k/T)$, $(1/T)$, ΔH^\ddagger and ΔS^\ddagger used for Eyring plots. An Eyring plot

Figure 2.2: NMR Simulations for $\bar{125}$.

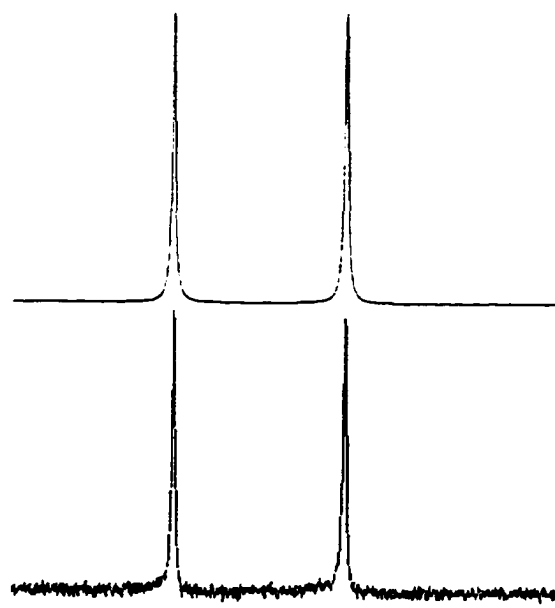

Temp: -72 °C, Rate = 0 Hz

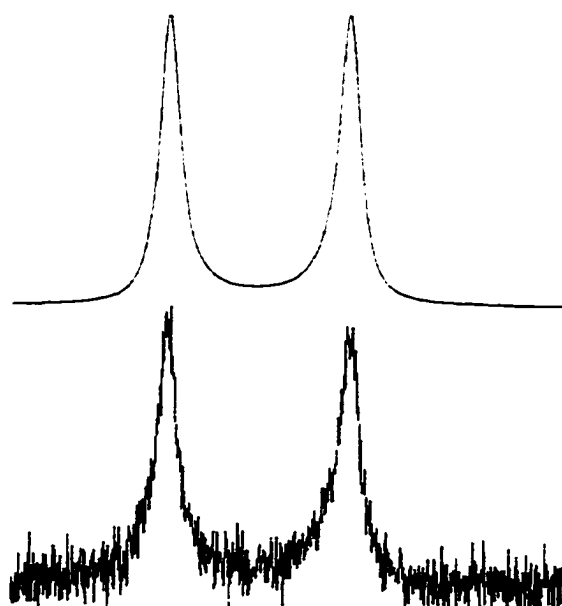

Temp: -44 °C, Rate = 42 Hz

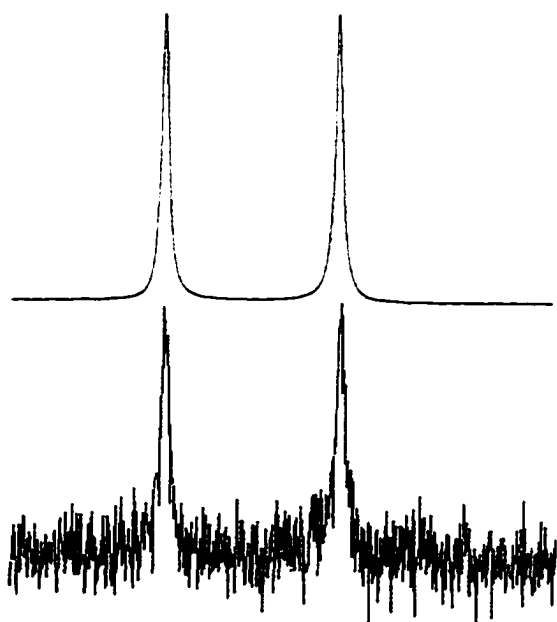

Temp: -50 °C, Rate = 12 Hz

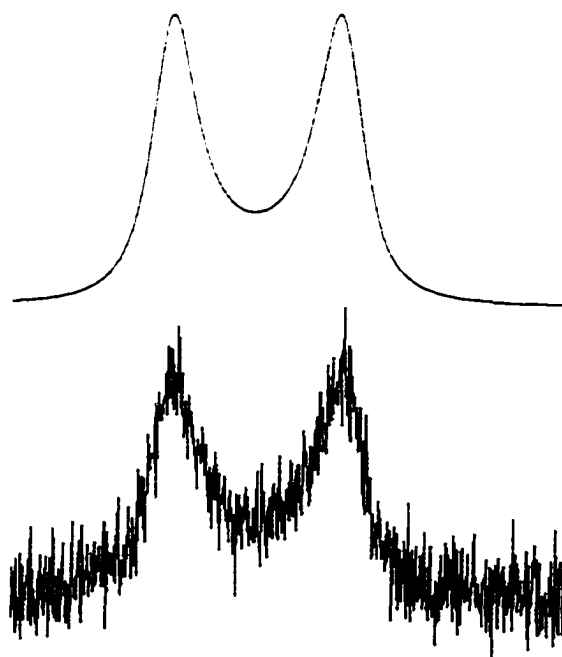

Temp: -34 °C, Rate = 105 Hz

Figure 2.2 (Continued)

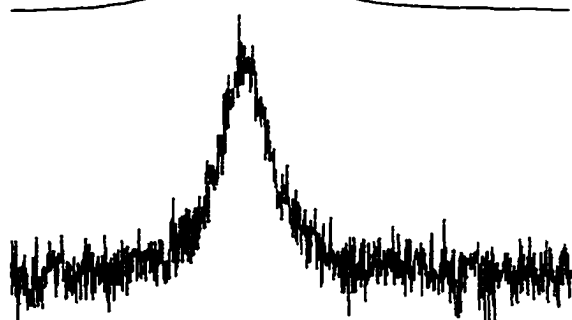
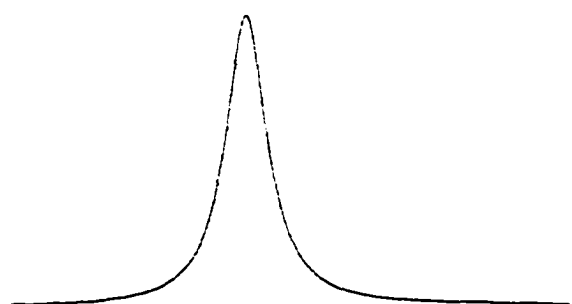

Temp: -15 °C, Rate = 675 Hz

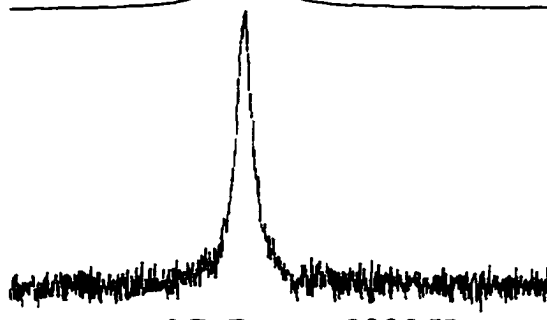
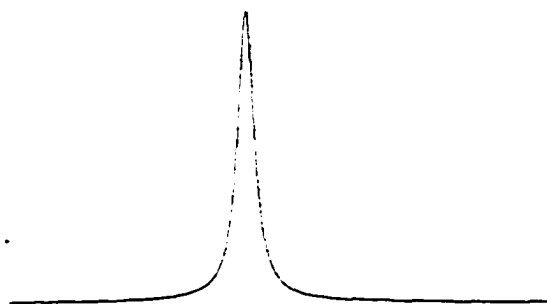

Temp: -1 °C, Rate = 2000 Hz

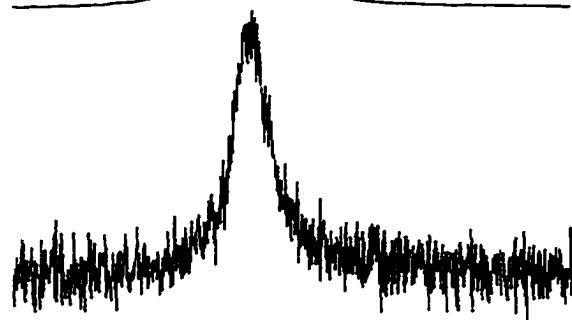
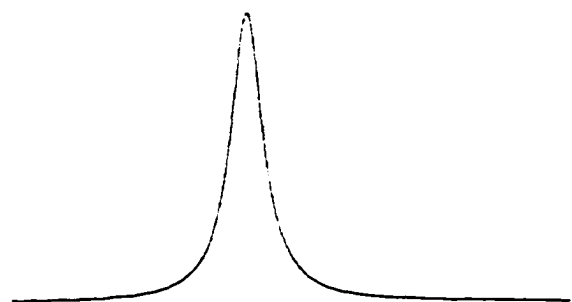

Temp: -11 °C, Rate = 950 Hz

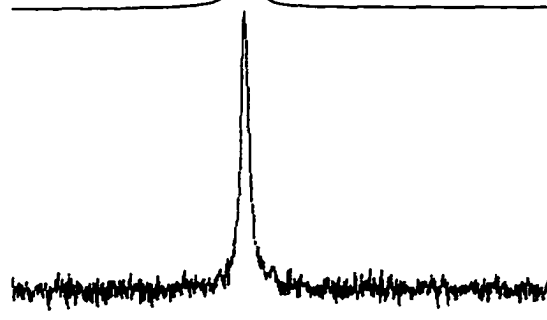
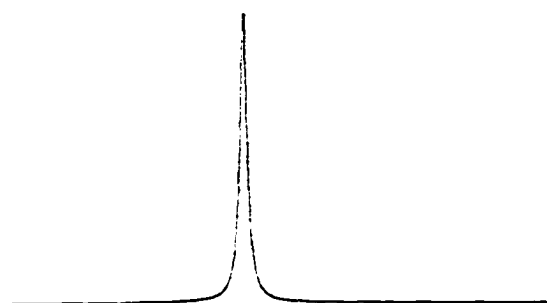

Temp: +15 °C, Rate = 7000 Hz

Table 2.3: Results of DNMR Simulations for 125.

Temp (°C)	Rate Constant (k) (sec ⁻¹)	ln (k/T)	1/T	ΔG [‡] (kcal/mol)
25	§	-----	-----	-----
15	7000	3.19	0.00347	11.78
1	2000	1.99	0.00365	11.86
-11	950	1.29	0.00381	11.71
-15	675	0.962	0.00387	11.70
-34	100	-0.872	0.00418	11.71
-43	42	-1.70	0.00434	11.64
-50	12	-2.92	0.00448	11.83
-73	†	-----	-----	-----

§ Fast exchange limit spectrum

For ln (k/T) vs (1/T)

† Slow exchange limit spectrum

Slope: -581.864 ± 488.451

Intercept: 23.3958 ± 1.94814

Std. Deviation of fit: 0.173459

of (ln k/T) versus (1/T) generates a line having a slope equal to $-\Delta H^\ddagger/R$. Using the data in Table 2.2, ΔH^\ddagger for the enantiomerization of *cis*-125 is 11.6 ± 0.97 kcal/mol.

Furthermore, ΔS^\ddagger can be calculated using the intercept of the Eyring plot. From the data in Table 2.2 ΔS^\ddagger was calculated to be -0.724 ± 1.95 cal/mol K.

$$k = \left(\frac{\kappa k_B T}{h} \right) e^{-(\Delta G^\ddagger/RT)} \quad \text{Equation 2.1a}$$

$$\Delta G^\ddagger = RT \left[\ln \left(\frac{k}{T} \right) + \ln \left(\frac{\kappa k_B}{h} \right) \right] \quad \text{Equation 2.1b}$$

$$\ln \left(\frac{\kappa k_B}{h} \right) = 23.75998(36) \quad \text{for } \kappa = 1$$

$$\Delta G^\ddagger = \Delta H^\ddagger - T\Delta S^\ddagger \quad \text{Equation 2.2}$$

$$\ln\left(\frac{k}{T}\right) = \left(\frac{-\Delta H^\ddagger}{R}\right) \frac{1}{T} + \left(\frac{\kappa k_B}{h}\right) + \left(\frac{\Delta S^\ddagger}{R}\right) \quad \text{Equation 2.3}$$

It is reasonable to assume that ΔG^\ddagger will not vary greatly with temperature based on the relatively low value of ΔS^\ddagger calculated for the enantiomerization. However, an estimated value for ΔG^\ddagger can be obtained at any temperature by extrapolating data from the Eyring plot and using Equation 2.1a. The ΔG^\ddagger for the enantiomerization of **85** was estimated to be 15.36 ± 0.2 kcal/mol at 57.5 ± 3 °C.¹⁰⁵ The estimated ΔG^\ddagger at 57.5 °C for *cis*-**125** is 11.8 kcal/mol. The difference in free energy of enantiomerization is a result of the torsional constraint introduced into one of the central six-membered rings of *cis*-**125** with respect to *cis*-**85**. In both cases, the enantiomerization requires that the ring systems undergo two ring inversions and all four nitrogens must be inverted. The presence of the two sp² carbons pry open the tetracyclic ring system of **125** with respect to **85** requiring less energy to complete the ring inversions. A three dimensional model of **125** is compared with the diamond-lattice conformation of **85** in Figure 2.4.

Figure 2.3: Enantiomerization of 125

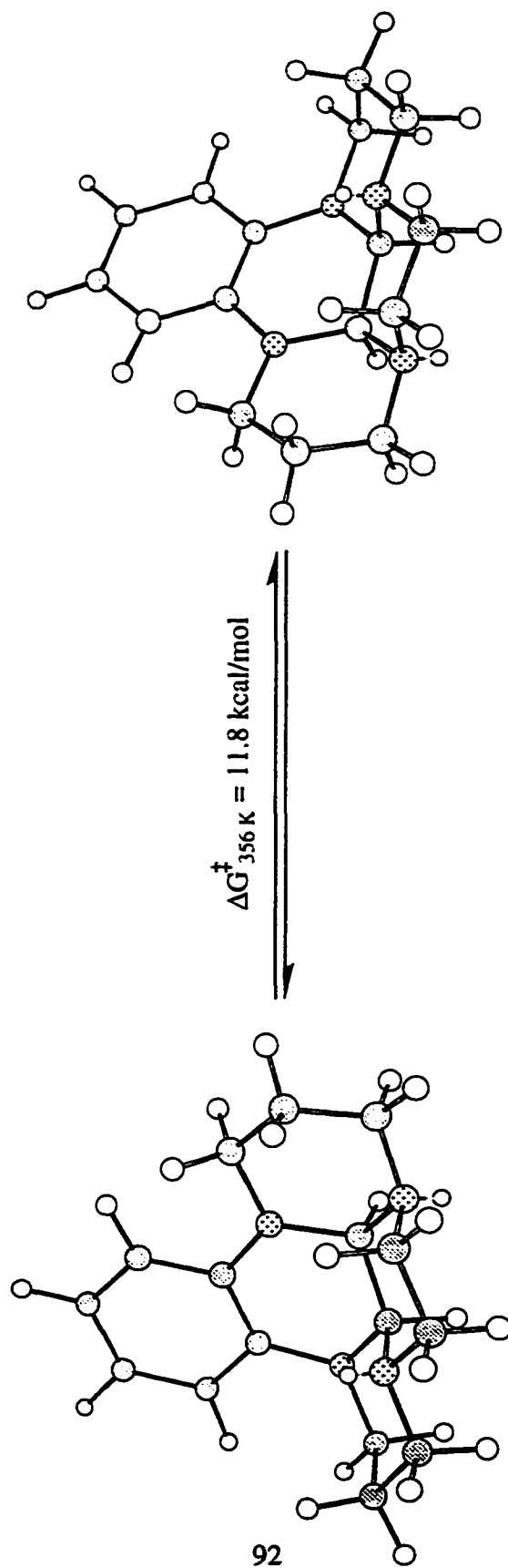
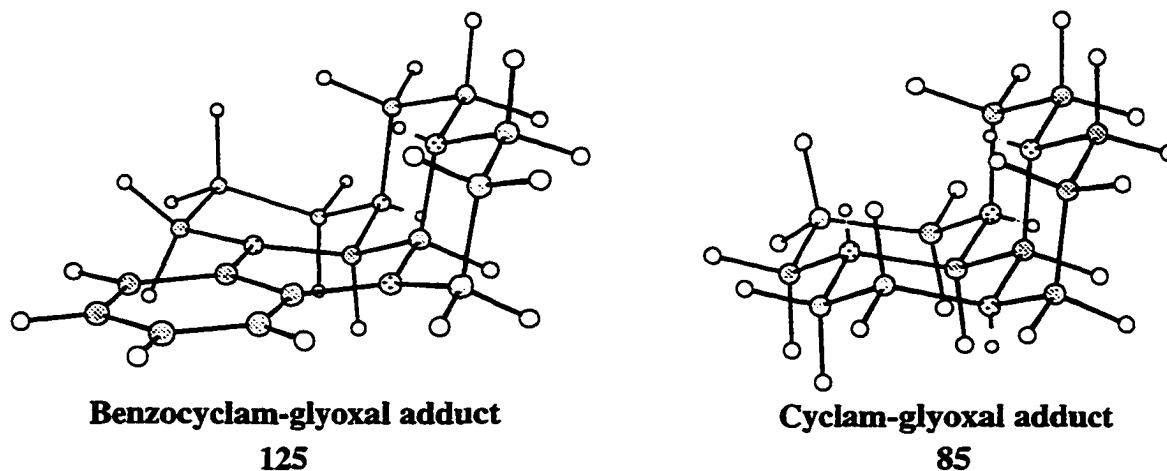

Figure 2.4: Molecular Models of 125 and 85 (MM2).



Reaction of Methyl Iodide and Benzyl Bromide with *Cis*-125.

Reaction of *cis*-125 with excess methyl iodide in CH_3CN at room temperature for 14 days afforded a white precipitate. ^1H NMR analysis of this precipitate was consistent with a mixture of mono and dimethylated *cis*-125. This material was recrystallized from CH_3CN . The recrystallized material gave a ^1H NMR spectrum consistent with the dialkylation of *cis*-125 whereby the product has two different methyl groups.

There are nine different isomeric dimethylated products which could give rise to this NMR spectrum. These isomers are shown in Scheme 2.32 (128a and 128d are excluded from this argument because the two methyl groups are symmetrically equivalent). Based on the MM2 calculated structure for *cis*-125 shown in Figure 2.4, 126a is the most likely product of this reaction. The first methylation should take place on one of the more nucleophilic nitrogens, not attached to the aromatic ring. Furthermore, this methylation

Scheme 2.32

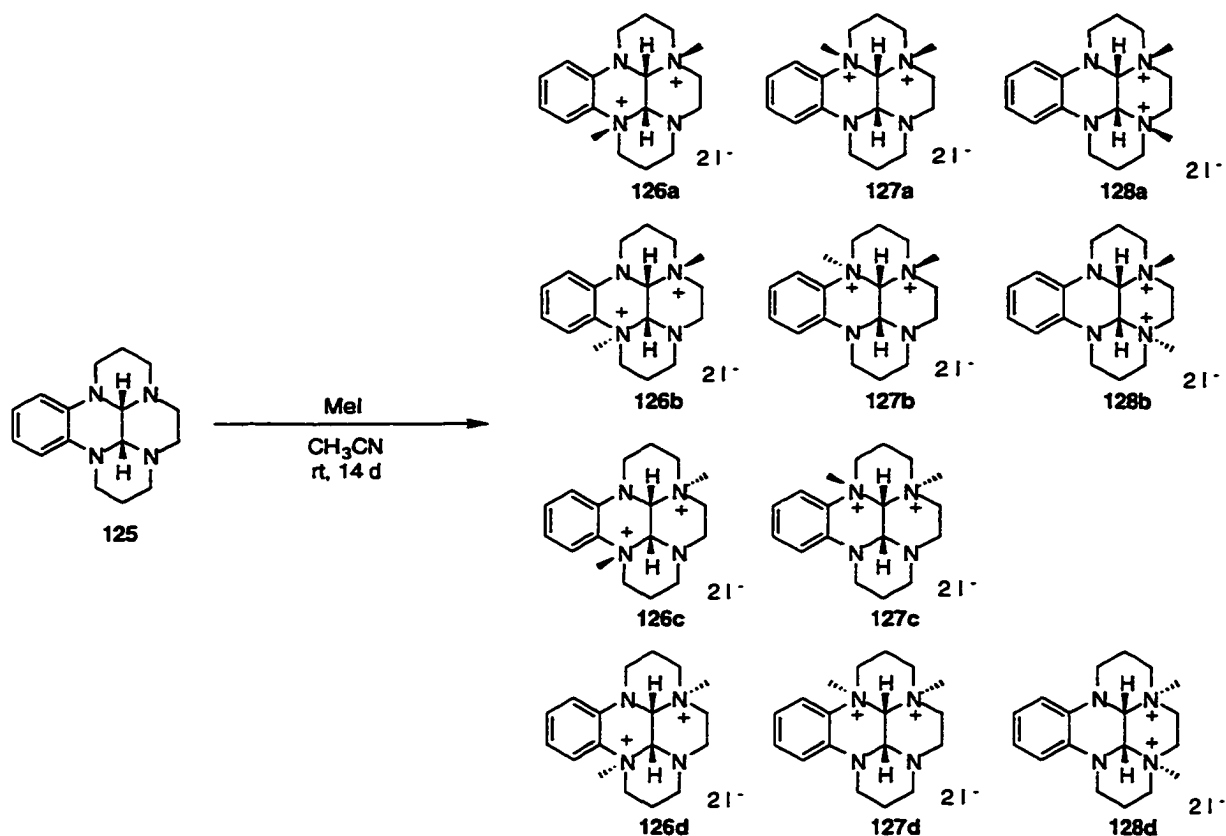

should occur on the most accessible lone pair which is *cis* to the methine hydrogens. The second methylation should take place on the nonadjacent nitrogen to minimize the repulsion of the positive charges. Additionally, methylation should proceed on the same face of the molecule as the first methylation because of sterics. For these reasons, **126a** should be formed preferentially over other isomers of **126** and any of the isomers of **127** and **128**.

Further work to characterize this material is needed. Less than 10 mg of sample were isolated in this reaction. Therefore, ¹³C NMR spectra having high enough signal to noise were not obtained in order to observe all of the resonances. Ideally, the

Scheme 2.33

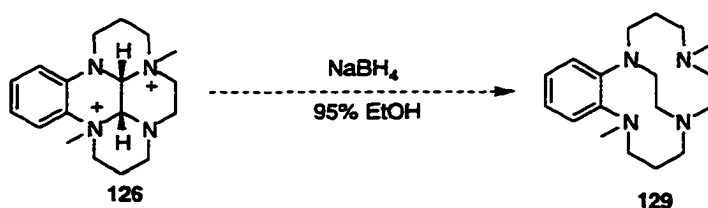

regiochemistry of the methylation of *cis*-**125** should be determined by an x-ray crystal structure. Following the successful preparation of **126a**, it is likely that NaBH_4 reduction of **126** will provide dimethyl cross-bridged benzocyclam (**129**).

Reaction of benzyl bromide (1.5 equivalents) with *cis*-**125** in toluene/ CH_3CN afforded a precipitate after stirring at room temperature for 14 days (Scheme 3.34). NMR

Scheme 2.34

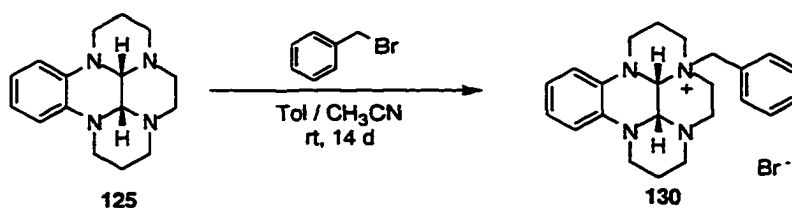

analysis of the solid was consistent with **130**. We believe that a monoalkylated derivative of *cis*-**125** could be reduced directly with DIBALH to give a cross-bridged benzocyclam derivative (**131**). This chemistry is shown in Scheme 2.35. Reaction of DIBALH with

Scheme 2.35

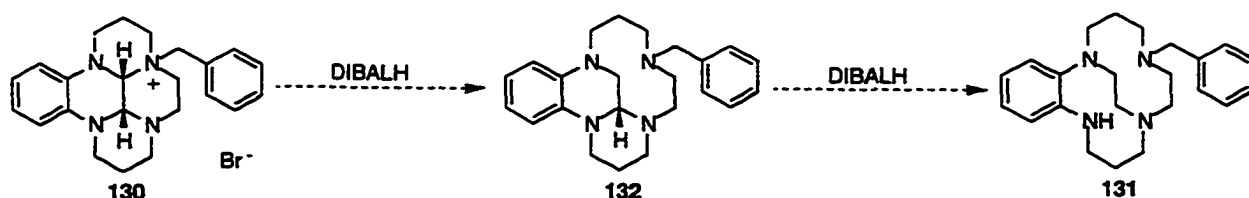

130 should cleave the C-N⁺ bond to afford **132**. Based on the chemistry reported by Yamamoto and Maruoka³⁸ on the regioselective reduction of amins by DIBALH, we believe that reduction of **132** will afford monobenzyl cross-bridged benzocyclam **131**. Preparation of **131** would provide a convenient synthetic pathway to functionalized cross-bridged benzocyclam derivatives. Possible targets which could be derived from **131** are shown in Scheme 2.36. Clearly, further work is needed to fully explore this chemistry.

Scheme 2.36

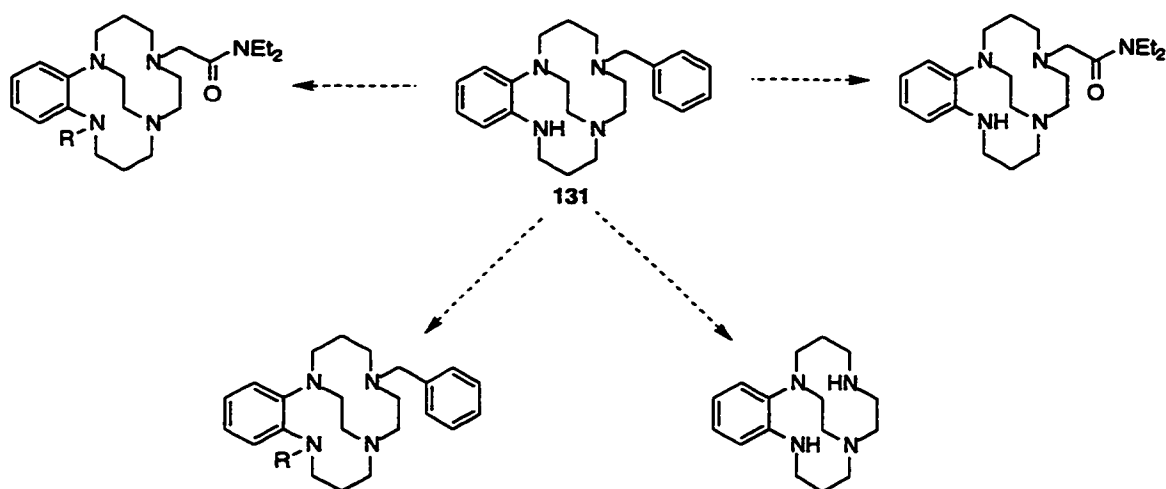

CHAPTER III

STUDIES ON THE COMPLEXATION OF SMALL CATIONS BY CROSS-BRIDGED CYCLAM DERIVATIVES

I. INTRODUCTION

As introduced in the previous chapter, there is a vast literature concerning complexation of cationic species by polyaza macrocyclic derivatives. The driving force behind the research in this area is the potential applications which exist in many different areas of science. Many applications involve the medical field in some manner, which has intensified the research effort to investigate the metal complexation properties of polyaza macrocyclic derivatives.

Significant interest has developed in ligands which complex transition metals having open coordination sites. Such complexes allow for the study of reactions at metal centers that have biological relevance. Other important applications for transition metal complexes center around the complexation of radiopharmaceuticals. Furthermore, there is also interest in main group cation complexes.

The rational design of cross-bridged cyclam derivatives prepared by Weisman, Wong and coworkers¹⁰¹ aimed to improve upon the complexation properties observed for cyclam. Weisman and Wong believed that cross-bridged cyclam derivatives would adopt low energy conformations which have all four nitrogen lone pairs convergent upon a cleft.

The cross-bridging of nonadjacent nitrogen atoms resulted in a cavity which could accommodate appropriately sized cations. It was believed that the cavity size was relatively small and the best ligand-metal interaction would be found for small cations. In fact, Weisman, Wong and coworkers reported that dimethyl cross-bridged cyclam **83** was a good complexer of Li^+ .¹⁰¹ The functionalization of cross-bridged cyclam by the attachment of pendant arms with ligating groups further expanded the potential utility of these ligands. Hill has reported a number of cross-bridged cyclam derivatives and investigated the complexation of Li^+ and Na^+ for some of these ligands.¹⁰³

A proposal to the National Institutes of Health (NIH), which was funded in 1997, outlined the research effort on cross-bridged cyclams.¹¹⁷ This chapter will address the experimental work relevant to this proposal on the complexation of Li^+ , Na^+ and Cu^{2+} .

II. BACKGROUND

As reported in the original publication on **83**,¹⁰¹ dimethyl cross-bridged cyclam formed complexes with LiClO_4 and NaBPh_4 . Furthermore these 1:1 complexes were each found to be in slow exchange with excess free ligand on the NMR time scale. Hill has reported, based on a ^{13}C NMR competition experiment, that **83** is a better complexer of Li^+ than Na^+ . In that ^{13}C NMR experiment, a 1:1:1 mixture of **83**, LiClO_4 and NaBPh_4 was observed in CD_3CN . A lower limit of $1.2\text{-}5.0 \times 10^2$ was placed on K_{rel} .¹⁰³ That is to say, **83** selectively complexes Li^+ in the presence of Na^+ . This work was later repeated by Hines using LiClO_4 and NaClO_4 in order to insure that the counterion was not influencing the experimental results. His results increased the lower limit of K_{rel} to 2.11×10^4 .⁸⁹

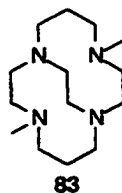

The Li^+/Na^+ selectivity observed in these experiments is very unusual. The development of a Li^+ sensor using cross-bridged cyclam derivatives has been proposed.¹¹⁷ There is a need for a method of detection for low concentrations of Li^+ in the presence of abundant Na^+ . Li^+ has a number of potential applications particularly in the medical field.^{130,131} Li^+ salts have been used in the treatment of some neurological and psychiatric disorders such as manic depression.^{132,133} Li^+ has also been reported to show antiviral activity against DNA type viruses.¹³⁴ Unfortunately, the use of Li^+ as a medicinal agent is limited because of its toxicity and the dosage of Li^+ introduced must be carefully controlled.

The therapeutic concentration of Li^+ in blood is 0.8-1.0 mM, however, side effects arise when the Li^+ concentration reaches 2-2.5 mM.¹³⁵ The presence of the abundant Na^+ ions (~140 mM in blood)¹³⁶ poses significant problems in monitoring the Li^+ concentration precisely. For these reasons, Li^+ ion selective electrodes (ISE's) are among the most investigated ISE's.¹³⁶⁻¹³⁸

Development of Li^+ ISE's has been reported,^{139,140} but they are limited by the inability to obtain very high ($>10^4$) Li^+/Na^+ selectivity.¹⁴¹ Ionophores utilized in ISE's are often either diamides or crown ether derivatives.¹³⁶ Li^+ is considered a hard acid which has a strong interaction with hard oxygen atoms.¹⁴²⁻¹⁴⁴ To a lesser extent, Li^+ also interacts with nitrogen atoms of amines.¹³¹ As shown by Hines⁸⁹ and Hill¹⁰³, dimethyl cross-bridged cyclam (**83**) does form good complexes with Li^+ resulting in high Li^+/Na^+ selectivity ($K_{\text{Li}^+/\text{Na}^+} > 2.11 \times 10^4$ for **83**)⁸⁹ making cross-bridged cyclam derivatives good candidates as Li^+ ISE's. Further investigation of the Li^+/Na^+ selectivity of other cross-bridged cyclam derivatives will be discussed in this chapter.

There is, however, a significant problem which must be overcome in order to investigate the utilization of cross-bridged cyclam derivatives as Li^+ sensors. The high basicity of these compounds severely limits their utility because cross-bridged cyclam derivatives are protonated in protic media. Therefore, new cross-bridged cyclam derivatives¹¹⁷ which should have decreased basicity with respect to **83** have been proposed. However, the structural modifications which lead to decreased basicity may also affect the Li^+ complexation properties of these new ligands. A decrease in the relative

complexation constants for new “less basic” cross-bridged cyclam derivatives would not necessarily pose difficulties in the development of Li⁺ ISE’s. These new ligands will still be very promising if the Li⁺/Na⁺ selectivity is maintained. Synthetic work on “less basic” cross-bridged cyclam derivatives has been described in Chapter II.

In 1996, the first transition metal complexes with cross-bridged ligands were reported.¹⁰⁴ In this communication, the synthesis of bicyclo[5.5.2] (**133**, **134**), [6.5.2] (**135**, **136**) and [6.6.2] (**91**, **92**) ring systems were presented as well as preliminary results on the complexation of Ni²⁺ and Cu²⁺ with these ligands. X-ray crystal structures for complexes of Cu²⁺ with **91** and **92** were reported. The complex with **91** had the Cu²⁺ in the ligand cavity coordinated to all four nitrogens in a distorted octahedral geometry. The Cu²⁺ had an agostic interaction with one of the *ortho*-hydrogens of one benzyl arm. The sixth coordination site was occupied by a Cl⁻. The two rings of the bicyclic ligand were in a slightly distorted [2323]/[2323] conformation as predicted. Similarly, the Cu²⁺ complex of **92** also had all four nitrogens convergent on the metal

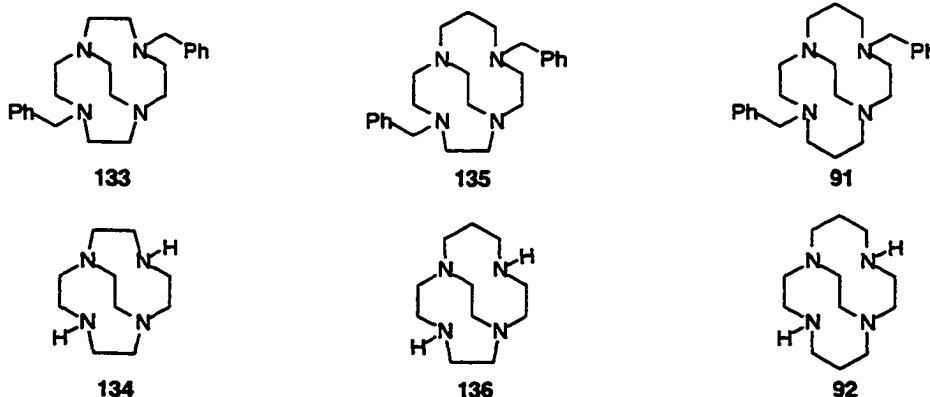

center. The coordination geometry of the copper center was a distorted trigonal bipyramid where a chloride counterion occupied the fifth site. The ligand in this complex was also in a slightly distorted [2323]/[2323] conformation. The study of other transition and main group metal complexes of cross-bridged cyclam ligands derivatives has continued in our group. Niu has prepared complexes of **91** with Zn^{2+} and **92** with Zn^{2+} , Ni^{2+} and Co^{2+} .¹⁴⁵

Another group has also recently published data in this area. Busch, Alcock and coworkers have synthesized **133**, **134**, **135**, **136**, **83**, **91** and **92** using our method and report that they have prepared metal complexes of these ligands with Cr^{2+} , Mn^{2+} , Mn^{3+} , Fe^{2+} , Fe^{3+} , Co^{2+} , Ni^{2+} , Cu^+ , Cu^{2+} and Zn^{2+} .¹⁴⁶ They further claim to have obtained x-ray crystal structures for Mn^{2+} , Mn^{3+} , Fe^{2+} , Fe^{3+} , Co^{2+} , Ni^{2+} , Cu^+ , Cu^{2+} and Zn^{2+} complexes with **133**, **134**, **83**, **91** and **92**. However only data for the $[Mn(83)Cl_2]$ were given. While there are some inconsistencies in this report with respect to our previously published and unpublished results, the conformation of the ligand and coordination of the ligand to the metal center for the Mn^{2+} complex reported by Busch and Alcock was consistent with our Cu^{2+} complexes.

It is not surprising that there is considerable interest in cross-bridged ligands because of the unusual stability observed for the metal complexes. This property is ideal for the development of many biological applications. There is, for example, considerable interest in reactions of biological significance which occur at metal centers. Reactions of this nature may possibly be modeled or mimicked by complexing the particular metal to a

cross-bridged ligand and utilizing the open coordination sites to perform chemical reactions. There are many processes in bioinorganic chemistry and catalysis which could be studied using cross-bridged ligands. Furthermore, metal cations such as In^{3+} as well as Cu^{2+} have utility as metal isotope agents (^{62}Cu , ^{64}Cu , ^{67}Cu , ^{111}In). Suitable radiopharmaceutical carriers^{13,17} must be ligands which have fast formation kinetics which result in complexes that are stable towards metal dissociation. Preliminary work on derivatives of cross-bridged cyclam complexed with Cu^{2+} shows promise that they may be candidates for radiopharmaceutical carriers. Studies on the complexation and the stability of the resulting complexes of other transition metal cations has also been proposed to investigate all of these potential applications.¹¹⁷

II. RESULTS AND DISCUSSION

General Method for the Calculation of K_{rel} and $\Delta\Delta G^\circ_{rel}$ for NMR Competition

Experiments for Cross-Bridged Cyclam Ligands

The complexation of many metal cations by cross-bridged cyclam derivatives can be monitored by NMR and, in most cases, slow exchange spectra for the free ligand and the complex are observed. Hill¹⁰³ and Hines⁸⁹ have reported the methodology used in direct competition experiments to measure or estimate the relative complexing abilities of cross-bridged cyclam ligands. This method has allowed for the comparison of the relative ability to complex Li^+ and Na^+ between ligands as well as the Li^+/Na^+ selectivity for a given ligand. This method has been applied to the new cross-bridged cyclam derivatives reported in Chapter II and a summary of the complexation abilities of all of the ligands which have been studied has been compiled.

The relative Li^+ complexation ability for a given ligand must be reported consistently. Therefore, one ligand was chosen to be the baseline for all of the competition experiments. This ligand is dimethyl cross-bridged cyclam (**83**). The data can then be compared to the monocyclic analog, tetramethylcyclam (**88**) by means of an experiment

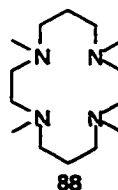
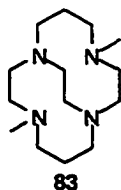

reported by Hines.⁸⁹ Hines performed a direct competition experiment between **83** and **88** for LiClO₄ using ¹H NMR as the method of detection. In that experiment, the competition equilibrium constant (K_{rel}) was determined to be (6.01±0.52) × 10³. This K_{rel} was used to calculate the free energy of competition (ΔΔG°_{rel}) which was reported as -5.10 ± 0.05 kcal/mol. From these data, **83** forms a much stronger complex with Li⁺ than does **88**.

The values of K_{rel} and subsequently ΔΔG°_{rel} were derived from information obtained from ¹H NMR integration. The case described above for the competition of **83** and **88** for LiClO₄ will be used as an example. An NMR sample was prepared in CD₃CN containing **83**, **88** and LiClO₄. The equilibrium expressions describing the species in solution are shown as Equation 3.1 and 3.2. The NMR experiment was set up such that **83**, **88** and LiClO₄ were present in a 1:1:1 molar ratio. Therefore, if essentially all of the Li⁺ is complexed by ligands at equilibrium, the total concentration of free ligands ([**83**] + [**88**]) must be equal to the total concentration of ligands complexed with Li⁺ ([**83**•Li⁺] + [**88**•Li⁺]). Furthermore, [**83**•Li⁺] must be equal to [**88**] and [**88**•Li⁺] must be equal to [**83**]. Having all of these conditions, Equation 3.2 can be simplified to Equation 3.3.

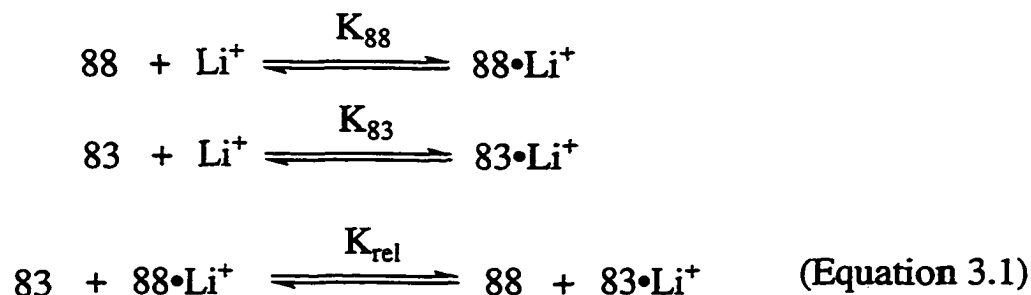

$$K_{\text{rel}} = \frac{K_{83}}{K_{88}} = \frac{[88] [83 \cdot \text{Li}^+]}{[83] [88 \cdot \text{Li}^+]} \quad (\text{Equation 3.2})$$

$$K_{\text{rel}} = \frac{[88]^2}{[83]^2} = \frac{[83 \cdot \text{Li}^+]^2}{[88 \cdot \text{Li}^+]^2} \quad (\text{Equation 3.3})$$

$$\Delta\Delta G^\circ_{\text{rel}} = -RT \ln K_{\text{rel}} \quad (\text{Equation 3.4})$$

$$R = 1.9872 \text{ cal/mol K}$$

$$T = 298.15 \text{ K}$$

Using ^1H NMR integrations for isolated resonances for **83** and **83**• Li^+ , K_{rel} was calculated. From Equation 3.4, $\Delta\Delta G^\circ_{\text{rel}}$ was calculated.

Complexation of 4,11-Bis-(N,N'-diethylacetamido)-1,4,8,11-tetraazabicyclo[6.6.2]hexadecane (**95**) with Li^+ and Na^+ .

Parker and coworkers reported the preparation of a series of [ane] N_3 derivatives and a cyclen derivative with amide arms.¹¹¹ The amide arms were designed to enhance the Li^+/Na^+ selectivity for these ligands over the parent structure.

The preparation of the analogous cross-bridged cyclam derivative (**95**) was reported in Chapter II. The complexation ability for Li^+ of **95** is expected to be much stronger than that of **83** as a result of the two ligating amide arms. Before the competition experiment could be carried out, control experiments were performed to determine which resonances would provide the necessary information. The Li^+ and Na^+ complexes of **95** were prepared in CD_3CN from LiClO_4 and NaClO_4 respectively. For each cation,

approximately 0.5 equivalents of the perchlorate salt was added to an equivalent of **95** in CD_3CN . ^{13}C NMR spectra were consistent with two distinct species whose spectra were consistent with free **95** and the complexed **95**. The complex exhibited twelve ^{13}C resonances (C_2 symmetry) and was in slow exchange with free **95** on the NMR time scale. Addition of another 0.5 equivalents of perchlorate salt afforded the fully complexed **95** in each respective control experiment. The chemical shifts for these complexes are given in Table 3.1. The $[\text{Li}(\mathbf{95})\text{ClO}_4]$ complex was isolated and an IR (KBr) spectrum was obtained. There was a single carbonyl stretching frequency (1631 cm^{-1}) observed at lower energy than that of the free ligand (1644 cm^{-1}). These data support both amide arms are coordinated to Li^+ in the complex. Unfortunately, we were unable to obtain crystals of high enough quality for x-ray crystallography.

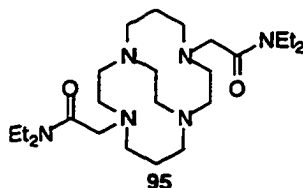

Competition: LiClO_4 and NaClO_4 for 4,11-Bis-(N,N'-diethylacetamido)-1,4,8,11-tetraazabicyclo[6.6.2]hexadecane (**95**).

Method of Detection: $^{13}\text{C}\{^1\text{H}\}$ NMR

Resonance Observed ($\mathbf{95}\cdot\text{Li}^+$): 53.10 ppm

Resonance Observed ($\mathbf{95}\cdot\text{Na}^+$): 51.33 ppm

Initial Concentration of **95**: $6.14 \times 10^{-2}\text{ M}$

Signal to Noise: 302:1

A competition was performed between LiClO_4 and NaClO_4 for **95** in CD_3CN (for sample preparation and data acquisition see Experimental Section). After inspection of the separate control ^1H NMR spectra of **95**, **95**• Li^+ , and **95**• Na^+ in CD_3CN , no isolated resonances which could be accurately integrated were found. Therefore, an estimate of $K_{\text{Li}^+/\text{Na}^+}$ was calculated based on the line heights of ^{13}C NMR resonances. The ^{13}C NMR resonances for **95**, **95**• Li^+ , and **95**• Na^+ in CD_3CN from the control experiments are given in Table 3.1. In the competition experiment, a single set of ^{13}C resonances was observed which was consistent with **95**• Li^+ . These resonances are also listed in Table 3.1. There was no detectable free **95** or **95**• Na^+ . Therefore, the largest resonance of **95**• Na^+ in the sample must be estimated to be less than or equal to the height of the noise of spectrum. A lower limit can be calculated for $K_{\text{Li}^+/\text{Na}^+}$, based on the signal to noise of the spectrum. Based on Equation 3.5, the competition equilibrium constant ($K_{\text{Li}^+/\text{Na}^+}$) for this competition was greater than or equal to 9.1×10^4 . The free energy of competition ($\Delta\Delta G_{\text{rel}}^\circ$) was calculated to be more negative than or equal to -5.4 kcal/mol at 25°C . Therefore, **95** is a much better complexer of Li^+ than Na^+ .

$$K_{\text{rel}} = \frac{K_{\text{Li}^+}}{K_{\text{Na}^+}} = \frac{[\text{95}\cdot\text{Li}^+][\text{Na}^+]}{[\text{95}\cdot\text{Na}^+][\text{Li}^+]} = \frac{[\text{95}\cdot\text{Li}^+]^2}{[\text{95}\cdot\text{Na}^+]^2} = \frac{[302]^2}{[1]^2} > 9 \times 10^4$$

(Equation 3.5)

for

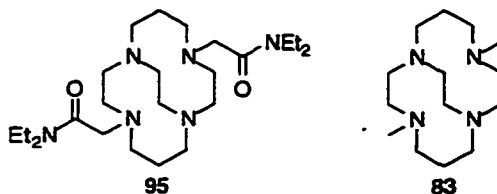

Table 3.1: ^{13}C Chemical Shifts for Complexation Experiments on 95 with LiClO_4 and NaClO_4 in CD_3CN .

95	95•Li⁺	95•Na⁺	Li⁺/Na⁺ Competition
13.40	13.57	13.23	13.54
14.69	14.69	14.67	14.68
28.73	26.15	25.69	26.15
40.24	41.73	41.72	41.73
41.89	42.47	42.77	42.44
52.66	53.10	50.91	53.10
55.03	53.10	51.33	53.10
57.71	59.18	58.09	59.18
57.76	59.75	59.30	59.75
58.15	61.08	59.89	61.08
59.44	62.36	60.26	62.35
170.83	172.23	172.08	172.22

Initial Concentration of 95 in the Competition: 6.14×10^{-2} M

Competition: 4,11-Bis-(N,N'-diethylacetamido)-1,4,8,11-tetraazabicyclo[6.6.2]hexadecane (95) and 4,11-Dimethyl-1,4,8,11-tetraazabicyclo[6.6.2]hexadecane (83) for Li⁺



Method of Detection: ¹³C{¹H} NMR

Resonance Observed (**95**•Li⁺): 26.15 ppm

Resonance Observed (Free **95**): 28.73 ppm

Initial Concentration of a Single Amine Component: 1.64 × 10⁻¹ M

Signal to Noise: 64:1

A competition was performed between **83** and **95** for LiClO₄ in CD₃CN (for sample preparation and data acquisition see Experimental Section). Upon inspection of the control ¹H NMR spectra of **83**, **95**, **83**•Li⁺, and **95**•Li⁺ in CD₃CN, no isolated resonances which could be accurately integrated in the competition were found. Therefore, an estimate of K_{rel} was calculated based on the line height of ¹³C resonances. The ¹³C resonances for **83**, **95**, **83**•Li⁺, and **95**•Li⁺ in CD₃CN are given in Table 3.2. In the competition experiment, two sets of ¹³C resonances were observed which were consistent with **95**•Li⁺ and **83**. These resonances are also listed in Table 3.2. There were minor resonances (~5% by line height) observed in this spectrum but the chemical shifts were consistent with **83**•H⁺. Since there was no detectable **95** or **83**•Li⁺ the largest resonance

$$K_{\text{rel}} = \frac{[95 \cdot \text{Li}^+][83]}{[83 \cdot \text{Li}^+][95]} = \frac{[95 \cdot \text{Li}^+]^2}{[83 \cdot \text{Li}^+]^2} = \frac{[63]^2}{[1]^2} > 4 \times 10^3$$

(Equation 3.6)

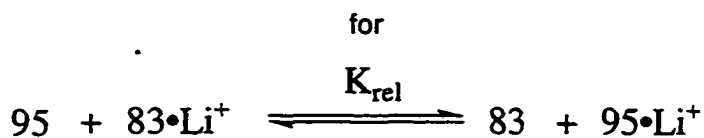

of **95** or $83 \cdot \text{Li}^+$ in the sample was estimated to be less than or equal to the height of the noise of the spectrum. A lower limit can therefore be calculated for K_{rel} , based on the signal/noise of the spectrum. Using Equation 3.6, the competition equilibrium constant (K_{rel}) for this competitions was greater than or equal to 4.1×10^3 . The free energy of competition ($\Delta\Delta G_{\text{rel}}^\circ$) was calculated to be more negative than or equal to -4.9 kcal/mol at 25°C . Therefore, **95** is a much better complexer of Li^+ than **83**.

These data also show that the amide arms enhance the complexation strength of this ligand. Hill performed a competition between **83** and **116** and found that **116** was also a better complexer of Li^+ than **83**.¹⁰³ However, the $\Delta\Delta G_{\text{rel}}^\circ$ was -2.05 ± 0.14 kcal/mol. Therefore **95** is an even better complexer of Li^+ than **116** as a result of the amide arms present on the ligand.

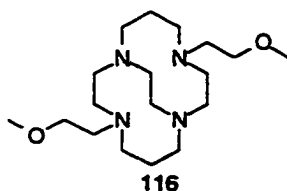

Table 3.2: ^{13}C Chemical Shifts for Competition Experiments on 95 and 83 for LiClO_4 in CD_3CN .

95	95•Li ⁺	83	83•Li ⁺	83•H ⁺	95/83 Competition		
					95•Li ⁺	83	83•H ⁺
13.40	13.57	-----	-----	-----	13.54	-----	-----
14.69	14.69	-----	-----	-----	14.69	-----	-----
28.73	26.15	28.69	24.59	24.99	26.13	28.62	25.01
40.24	41.73	-----	-----	-----	41.70	-----	-----
41.89	42.47	43.02	46.57	43.71	42.47	43.08	43.76
52.66	53.10	52.28	51.75	52.41	53.08	52.33	-----
55.03	53.10	56.81	52.20	52.97	53.08	56.73	-----
57.71	59.18	56.96	58.89	54.16	59.14	56.97	52.24
57.76	59.75	57.77	58.94	58.17	59.73	57.70	58.21
58.15	61.08	61.67	59.64	58.49	61.07	61.53	58.65
59.44	62.36	-----	-----	-----	62.33	-----	-----
170.83	172.23	-----	-----	-----	172.21	-----	-----

Initial Concentration of 95 and 83 in the Competition: 1.64×10^{-1} M

Data for 83 and 83•Li⁺ originally recorded by M.E. Rogers

Complexation of 4,11-Bis-(2-carboethoxymethyl)-1,4,8,11-tetraazabicyclo[6.6.2]hexadecane (137) with LiClO₄ and NaClO₄ in CD₃CN.

Hill prepared ester-armed cross-bridged cyclam derivative **137**.¹⁰³ As observed for **95**, **137** was expected to exhibit enhanced Li⁺ complexation with respect to the dimethyl derivative **83**. Before the competition experiment could be carried out, control experiments were performed to determine which resonances would provide the necessary information. The Li⁺ and Na⁺ complexes of **137** were prepared in CD₃CN from LiClO₄ and NaClO₄ respectively. For each cation, approximately 0.5 equivalents of the perchlorate salt was added to an equivalent of **137** in CD₃CN. In each case, ¹³C NMR spectra exhibited two distinct species whose shifts were consistent with free **137** and the complexed **137**. Each complex exhibited ten ¹³C resonances (C₂ symmetry) and was in slow exchange with free **137** on the NMR time scale. Addition of another 0.5 equivalents of perchlorate salt afforded the fully complexed **137** in each respective control experiment.

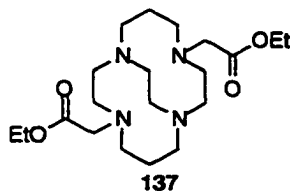

Competition: 4,11-Bis-(2-carboethoxymethyl)-1,4,8,11-tetraazabicyclo[6.6.2]hexadecane (137) for LiClO₄ vs. NaClO₄

Method of Detection: ¹H NMR

Resonance Observed (Complex 137•Li⁺): 3.53 ppm (2H)

Resonance Observed (Complex (137•Na⁺)): 3.49 ppm (2H)

Initial Concentration of a Single Amine Component: 4.24 × 10⁻² M

The relative complexing ability of 137 for LiClO₄ over NaClO₄ was determined by means of an ¹H NMR competition experiment. A 1:1:1 molar mixture of 137, LiClO₄ and NaClO₄ in CD₃CN was prepared. Fortunately, there were resonances for each complex which were not overlapped with other portions of the ¹H NMR spectrum, which allowed for the direct comparison of the quantities of 137•Li⁺ and 137•Na⁺ by integration. From this NMR experiment it is clear that the predominant species is 137•Li⁺ but there is a detectable amount of 137•Na⁺. Multiple integrations of these two resonances were performed to provide the data in Table 3.3.

The competition equilibrium constant (K_{Li^+/Na^+}) was calculated from Equation 3.7 as $(4.94 \pm 0.536) \times 10^1$ at 95% confidence. The free energy of competition ($\Delta\Delta G^\circ_{rel}$) was calculated as -2.31 ± 0.107 kcal/mol. Therefore, as predicted, 137 is a much complexer of Li⁺ than Na⁺. Based on this $\Delta\Delta G^\circ_{rel}$, 137 is equally effective in complexing Li⁺ as the ether-armed derivative (116) reported by Hill.

Table 3.3: Results of the Competition Experiment of LiClO₄ vs. NaClO₄ for 137 in CD₃CN

Integration	¹³⁷ Li ⁺ (δ 3.53)	¹³⁷ Na ⁺ (δ 3.49)	Ratio ¹³⁷ (Li ⁺ /Na ⁺)	(% ¹³⁷ Li ⁺ /% ¹³⁷ Na ⁺)
1	29474.31	3619.631	8.142905	89.1/10.9
2	30593.11	4340.257	7.048686	87.6/12.4
3	29401.75	3514.569	8.365677	89.3/10.7
4	31453.12	5043.202	6.236736	86.2/13.8
5	30090.83	4045.434	7.438220	88.1/11.9
6	31076.23	4780.051	6.501234	86.7/13.3
7	31179.79	4844.420	6.436228	86.6/13.4
8	30301.22	4265.685	7.103483	87.7/12.3
9	31031.99	4713.123	6.584167	86.8/13.2
10	31191.07	4863.574	6.413199	86.5/13.5
Average(\bar{x})	30579.34	4402.995	7.027054	87.5/12.5

Initial Concentration of 137 in the Competition: 4.24×10^{-2} M

Standard Deviation of Ratio ¹³⁷(Li⁺/Na⁺) (\bar{x}): 0.74800

$$K_{\text{rel}} = \frac{K_{\text{Li}^+}}{K_{\text{Na}^+}} = \frac{[^{137}\text{Li}^+][\text{Na}^+]}{[^{137}\text{Na}^+][\text{Li}^+]} = \frac{[^{137}\text{Li}^+]^2}{[^{137}\text{Na}^+]^2} = \frac{[30579.34]^2}{[4402.995]^2} = 49.4 \pm 5.4$$

(Equation 3.7)



Competition: 4,11-Bis-(2-carboethoxymethyl)-1,4,8,11-tetraazabicyclo[6.6.2]hexadecane (137) and 4,11-Dimethyl-1,4,8,11-tetraazabicyclo[6.6.2]hexadecane (83) for LiClO₄

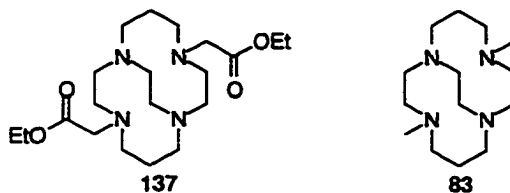

Method of Detection: ¹H NMR

Resonance Observed (137•Li⁺): 3.53 ppm (2H)

Resonance Observed (83•Li⁺): 3.39 ppm (2H)

Initial Concentration of a Single Amine Component: 4.94 x 10⁻² M

Surprisingly, analysis of the ¹H NMR spectrum 30 minutes after the preparation of this competition sample was consistent with 83•Li⁺ as the major component. In fact, the ratio of 83•Li⁺:137•Li⁺ was approximately 86:14 based on ¹H NMR integrations of the two complexes. These results were in contradiction to the expected results based on the other competitions which had been carried out. The same sample was reevaluated three hours later. The ratio of the two complexes had shifted during this time and was much closer to 50:50.

Therefore, thermodynamic equilibrium had not been reached. This result could be rationalized if the experiment had been biased during sample preparation. If the LiClO₄ had been added to 83 forming 83•Li⁺, the 83•Li⁺ complex must then decomplex Li⁺ by some mechanism to allow 137 to complex with Li⁺. Unfortunately, the order of addition was not recorded in the experimental details.

The ^1H NMR spectrum was monitored over time to determine when equilibrium had been reached. The ratio of $83\text{-Li}^+ : 137\text{-Li}^+$ after 18 hours had shifted to favor 137-Li^+ . There was, however, another process taking place during the equilibration. A resonance whose chemical shift was consistent EtOH was detected at 1.11 ppm. This resonance was not observed in the previous spectra for this sample. EtOH was generated by the hydrolysis of the ester arm of 137-Li^+ . It is hypothesized that the Li^+ complexed with the carbonyl of **137** catalyzed the hydrolysis of the ester to a carboxylate by the water present in the sample. In fact, the resonance for water in this sample was also reduced as a function of time, which is consistent with hydrolysis. ^1H NMR spectra after 2 days and 6 days did not show significant further conversion of 83-Li^+ to 137-Li^+ but hydrolysis of the ester had progressed such that the water resonance could not be detected in the 6 day spectrum. Representative spectra from this experiment are shown in Figure 3.1.

Figure 3.1: ^1H NMR Data for the Competition of 137 vs 83 for LiClO_4 .

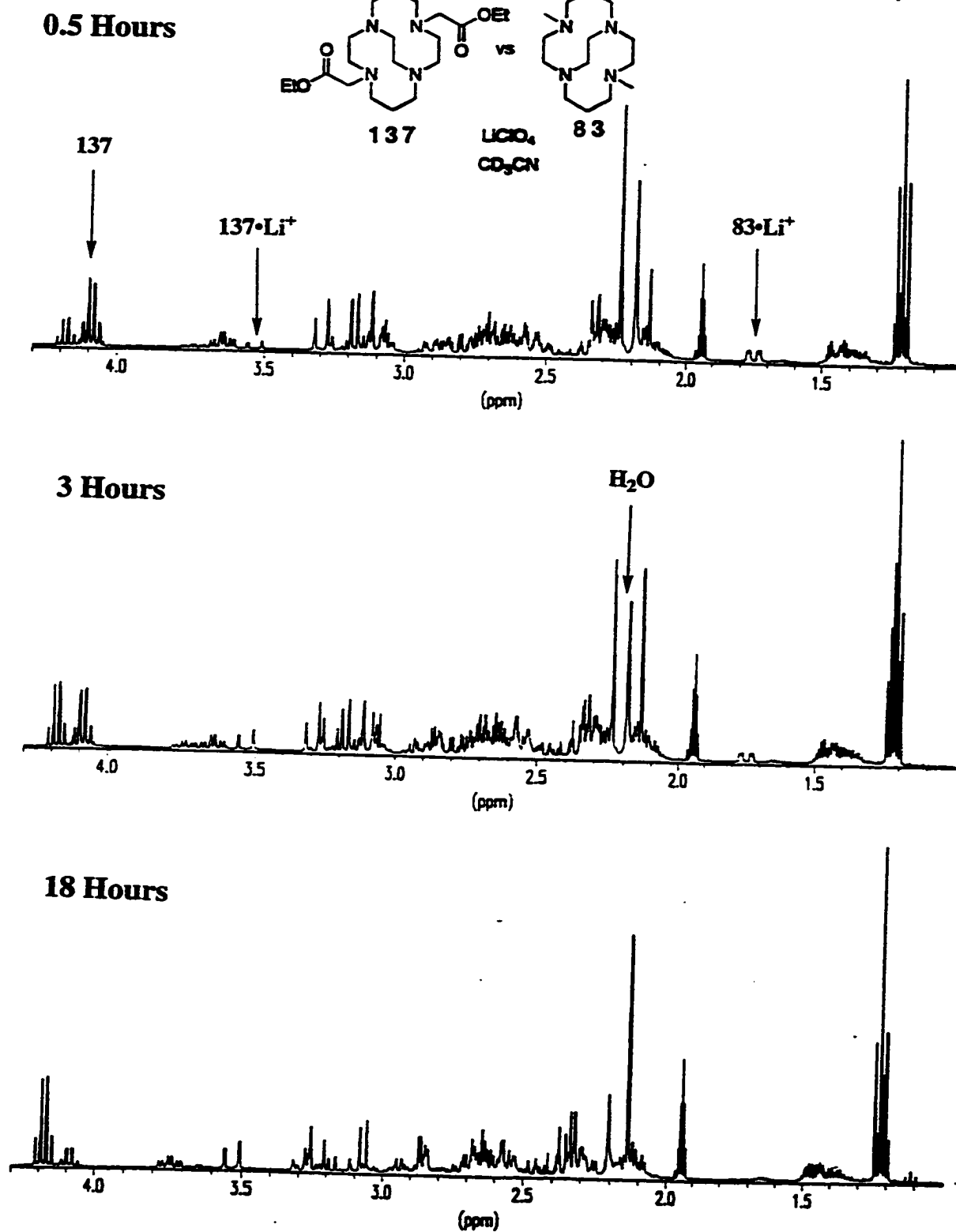
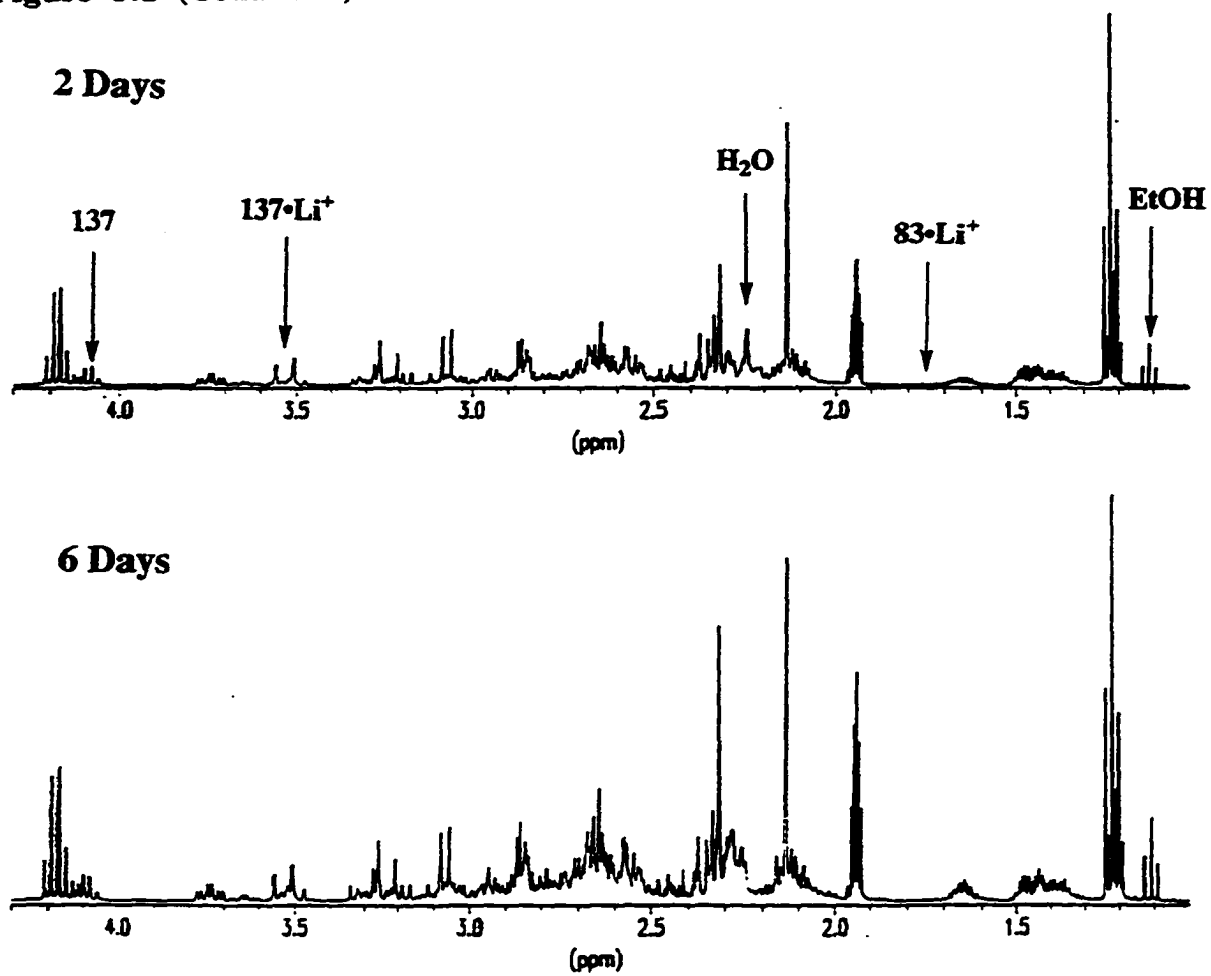
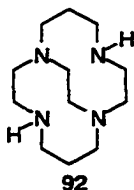

Figure 3.1 (Continued)



Complexation of 1,4,8,11-Tetraazabicyclo[6.6.2]hexadecane (**92**) with H⁺, LiClO₄ and NaClO₄ in CD₃CN.



The ¹H NMR data for **92** is consistent with the two secondary amino hydrogens being inside the cavity of the ligand, hydrogen bonded to the lone pairs of the tertiary nitrogen atoms. The chemical shift for these protons is found downfield at approximately 3.5 ppm in various NMR solvents (CDCl₃, ¹⁰³C₆D₆, ¹⁰³CD₃CN). The fact that this resonance for the NH protons is not significantly shifted in different solvents supports the hypothesis that the protons are located on the inside of the cavity. Therefore, in order for **92** to complex a cation, the two secondary amino nitrogens must be inverted to remove the two protons from the cavity. It is possible that the presence of the two amino protons already inside the cavity may result in **92** being less basic than other fully substituted cross-bridged cyclam derivatives. The protonation of **92** would be expected to occur on one of the secondary amino lone pairs exposed to solvent and *not* a lone pair inside the cavity. Therefore, the pK_a of this species should be closer to that of a typical secondary amine.

To support this argument, an NMR experiment was performed whereby **92** was treated with trifluoroacetic acid (TFA) in CD₃CN. We expected that there might be an exchange process that interconverted the “inside” protons with the “outside” proton. This

exchange process must involve inversion of the secondary amino nitrogens and either intermolecular or intramolecular proton transfers. If this interconversion was slow on the NMR time-scale two separate proton resonances would be observed in a 2:1 ratio. However, this process is not slow and a single proton resonance was observed in the ^1H NMR. Addition of an equivalent of TFA afforded $92\cdot\text{H}^+$ which had a single NH resonance at 7.44 ppm in CD_3CN . Addition of a second equivalent of TFA afforded $92\cdot 2\text{H}^+$. The ^1H NMR spectrum of $92\cdot 2\text{H}^+$ had two distinct NH resonances (9.27, 10.19 ppm), one more broad than the other (10.19 ppm). This species should have both “outside” lone pairs protonated and has no *exposed* lone pairs available to intermolecularly shuffle protons. Therefore, the rate of exchange of protons is slower in this case and two distinct resonances were observed. It is likely that the broader resonance observed further downfield corresponds to the “outside” protons which are in slightly faster exchange than the “inside” protons. The ^1H NMR spectrum is also consistent with diamond lattice conformations for the two 14-membered rings. The two upfield multiplets are nicely resolved into a doublet of pentets (dp, 1.61 ppm) for the pseudo-equatorial protons and a quartet of triplets (qt, 2.18 ppm) for the pseudo-axial protons of the methylenes β to nitrogen atoms in the 14-membered rings. These data further support the hypothesis that there are two protons with bifurcated hydrogen bonds inside the cavity. An aliquot of this NMR sample was removed and diluted (10:1) with CD_3CN . The ^1H NMR of this sample was unchanged with respect to the more concentrated sample. We hoped that addition of D_2O to the NMR sample would provide further insight concerning $92\cdot 2\text{H}^+$. If a small

amount of D₂O was available to exchange with the protons it is reasonable that the “outside” protons must exchange first. Therefore, that resonance should decrease in area faster than the resonance for the “inside” protons. Unfortunately, by the time the 3 μL of D₂O had been added and the ¹H NMR spectrum acquired, both types of protons had exchanged.

In all cases presented to this point, cross-bridged ligands have complexed Li⁺ and Na⁺ so effectively that free ligand has never been observed for 1:1 molar mixtures of ligand:metal. However, **92** was not as effective as a result of the two “inside” protons which are hydrogen bonded to the nitrogen lone pairs in the cavity. A 1:1 molar mixture of **92** and LiClO₄ in CD₃CN was prepared and the NMR data was consistent with **92**•Li⁺ and free **92**. Two sets of ¹³C NMR resonances were observed for this sample, each having six lines, confirming that **92**•Li⁺ and **92** were in slow exchange on the NMR time scale. Addition of another 0.3 equivalents of LiClO₄ gave a ¹³C NMR spectrum consistent with fully complexed **92**•Li⁺ which had only one set of six resonances.

The same experiment between **92** and NaClO₄ did not have similar results. The ¹H NMR spectrum of the 1:1 molar mixture of **92** and NaClO₄ was consistent with **92**. However, the ¹³C NMR chemical shifts observed for this mixture varied slightly from the shifts of authentic **92**. Furthermore, these resonances were slightly broadened. Therefore, the exchange of Na⁺ between free and Na⁺-complexed **92** is fast on the ¹³C NMR time scale. The mixture, however, must be predominantly composed of **92** because the chemical shifts for the mixture are only slightly different than those observed for free **92**.

Competition: 1,4,8,11-Tetraazabicyclo[6.6.2]hexadecane (92) and 4,11-Dimethyl-1,4,8,11-Tetraazabicyclo[6.6.2]hexadecane (83) for LiClO₄

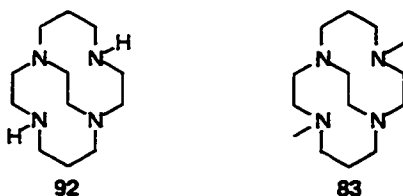

Method of Detection: ¹³C{¹H} NMR

Resonance Observed (**83**•Li⁺): 24.24 ppm (NCH₂CH₂CH₂N)

Resonance Observed (**92**•Li⁺): 24.33 ppm (NCH₂CH₂CH₂N)

Resonance Observed (**83**): 28.70 ppm (NCH₂CH₂CH₂N)

Resonance Observed (**92**): 25.24 ppm (NCH₂CH₂CH₂N)

Initial Concentration of a Single Amine Component: 5.96 × 10⁻² M

A competition was performed between **83** and **92** in CD₃CN (for sample preparation and data acquisition see Experimental Section). Upon inspection of the ¹H NMR spectra of **83**, **92**, **83**•Li⁺, and **92**•Li⁺ in CD₃CN, no isolated resonances which could be accurately integrated were found. Therefore, an estimate of K_{rel} was calculated based on the ¹³C NMR spectrum. The ¹³C NMR resonances for **83**, **92**, **83**•Li⁺, and **92**•Li⁺ in CD₃CN are given in Table 3.4. The most abundant species in the competition experiment were **92** and **83**•Li⁺ but some resonances for **83** and **92**•Li⁺ were also found. Provided the T₁'s and NOE's for the free ligands (**83** and **92**) and the T₁'s and NOE's for the Li⁺ complexes (**83**•Li⁺, and **92**•Li⁺) for respective carbons are not significantly different, K_{rel} can be calculated. The integration for each respective carbon

can be used in Equation 3.8 to calculate K_{rel} . These data are presented in Table 3.5. K_{rel} was calculated to be $(1.73 \pm 0.085) \times 10^2$ (at 95% confidence) which corresponds to a $\Delta\Delta G^\circ_{rel}$ of -3.05 ± 0.028 kcal/mol. Therefore, **83** is a better complexer of Li^+ than **92** as predicted.

Table 3.4: ^{13}C Chemical Shifts for Competition Experiments on **92 and **83** for $LiClO_4$ in CD_3CN .**

92	92•Li ⁺	83	83•Li ⁺	Competition			
				major		minor	
				92	83•Li ⁺	83	92•Li ⁺
25.27	24.32	28.69	24.59	25.24	24.61	28.70	24.32
47.41	43.52	43.02	46.57	47.40	46.59	----	43.54
51.31	48.36	52.28	51.75	51.25	51.76	----	48.37
52.70	52.37	56.81	52.20	52.71	52.21	----	----
56.67	59.75	56.96	58.89	56.61	58.91	----	----
59.99	60.76	57.77	58.94	59.99	58.93	----	----
----	----	61.67	59.64	----	59.67	61.65	----

Initial Concentrations of **92** and **83** in the Competition: 5.96×10^{-2} M

Data for **83** and **83•Li⁺** originally recorded by M.E. Rogers

$$K_{rel} = \frac{[83 \cdot Li^+][92]}{[92 \cdot Li^+][83]} = (1.73 \pm 0.085) \times 10^2$$

(Equation 3.8)

for



Table 3.5: Results for the Competition Experiment of 92 and 83 for LiClO₄ in CD₃CN.

Integration	Free 83 (δ 28.70)	Free 92 (δ 25.24)	83•Li ⁺ (δ 24.61)	92•Li ⁺ (δ 24.32)	K _{rel}
1	42123.39	1435870	1905061	449795.9	144.3727
2	31765.84	1417843	1890356	471506.8	178.9466
3	31489.31	1405029	1892123	485371.3	173.9392
4	31697.71	1414211	1891157	474824.8	177.6972
5	31605.83	1406864	1892889	484819.4	173.7921
6	31900.07	1423293	1890181	464675.9	181.4913
7	31418.51	1396332	1893907	497773.8	169.0946
8	31922.18	1427414	1887262	443874.4	190.1207
9	31489.31	1405029	1892123	485371.3	173.9392
10	31342.34	1395460	1894512	498339.3	169.2615
Average (\bar{x})	32675.45	1412735	1892957	475635.3	173.2655

Initial Concentrations of 92 and 83 in the Competition: 5.96×10^{-2} M

Standard Deviation for K_{rel}: 11.89343

Competition: 1,4,8,11-Tetraazabicyclo[6.6.2]hexadecane (92) and Tetramethylcyclam (88)

(88) for LiClO₄⁻

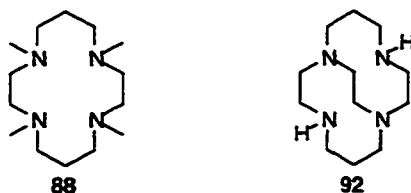

Method of Detection: ¹³C{¹H} NMR

Resonance Observed (**88**•Li⁺): 24.24 ppm (NCH₂CH₂CH₂N)

Resonance Observed (**92**•Li⁺): 24.33 ppm (NCH₂CH₂CH₂N)

Resonance Observed (**88**): 28.70 ppm (NCH₂CH₂CH₂N)

Resonance Observed (**92**): 25.24 ppm (NCH₂CH₂CH₂N)

Initial Concentration of a Single Amine Component: 8.51 × 10⁻² M

The same competition experiment was performed between tetramethylcyclam (**88**) and **92** in CD₃CN (for sample preparation and data acquisition see Experimental Section). An estimate of K_{rel} was calculated base on the ¹³C spectrum. The ¹³C resonances for **88**, **92**, **88**•Li⁺, and **92**•Li⁺ in CD₃CN are given in Table 3.6. The same assumption concerning the T₁'s and NOE's can be made in this case as was made for the competition between **83** and **92** for Li⁺. The data for the integrations is presented in Table 3.7. The integration for each respective carbon was used in Equation 3.9 to calculate K_{rel}. K_{rel} was calculated to be 1.88 ± 0.047 which corresponds to a ΔΔG^o_{rel} of -0.374 ± 0.015 kcal/mol.

As mentioned earlier in this section, Hines performed the competition of **83** and **88** for LiClO₄.⁸⁹ From that experiment, K_{rel} was calculated to be -(6.01±0.52) × 10³ in favor

Table 3.6: ^{13}C Chemical Shifts for the Competition Experiment for **92 and **88** with LiClO_4 in CD_3CN .**

92	92•Li⁺	88	88•Li⁺	92	Competition		88•Li⁺
					92•Li⁺	88	
25.27	24.32	25.80	23.34	25.29	23.44	25.78	23.32
47.41	43.52	43.48	42.64	47.35	43.53 [§]	43.53 [§]	42.73
51.31	48.36	-----	43.19 [†]	51.34	48.37	-----	43.53 [§]
52.70	52.37	55.13	55.91	52.52	52.37	55.16	56.02
56.67	59.75	55.75	57.68	56.24	59.78	55.74	57.78 [§]
59.99	60.76	-----	60.46 [†]	59.78 [§]	60.79 [§]	-----	60.78 [§]

Initial Concentrations of **92** and **88** in the Competition: 8.51×10^{-2} M

Data for **88** and **88•Li⁺** recorded by M.S. Hines

[†] Resonance was broad

[§] Resonances were overlapping

$$K_{\text{rel}} = \frac{[\text{88}\cdot\text{Li}^+][\text{92}]}{[\text{92}\cdot\text{Li}^+][\text{88}]} = 1.88 \pm 0.047$$

(Equation 3.9)



Table 3.7: Results of the Competition Experiment on 88 vs. 92 for LiClO₄ in CD₃CN.

Integration	Free 88 (δ 25.78)	Free 92 (δ 25.29)	92•Li ⁺ (δ 24.32)	88•Li ⁺ (δ 23.42)	K _{rel}
1	3.351253	4.325718	2.348412	3.342709	1.837280
2	3.305257	4.337708	2.376626	3.340714	1.844733
3	3.254040	4.378045	2.398162	3.386639	1.899974
4	3.406156	4.240905	2.316787	3.220567	1.730774
5	3.227081	4.392984	2.408133	3.403123	1.923742
6	3.271995	4.36079	2.387566	3.363103	1.877316
7	3.221981	4.40442	2.415858	3.422006	1.936311
8	3.189891	4.422523	2.427265	3.447087	1.968926
9	3.249717	4.377082	2.397738	3.381875	1.899743
10	3.271995	4.360790	2.387566	3.363103	1.877316
Average (\bar{x})	3.274934	4.360100	2.386411	3.367093	1.879611

Initial Concentrations of 92 and 88 in the Competition: 8.51×10^{-2} M

Standard Deviation for K_{rel}: 0.0659386

of $83 \cdot \text{Li}^+$ over $88 \cdot \text{Li}^+$. However, as reported in this chapter, **88** and **92** complex LiClO_4 approximately equally having a K_{rel} of 1.88 ± 0.047 in favor of **88** complexation. Therefore, one would predict that the K_{rel} for the competition of **83** and **92** for LiClO_4 should have a K_{rel} on the order of 10^3 . The K_{rel} for that experiment was calculated to be $(1.73 \pm 0.085) \times 10^2$. These data are not internally consistent. As far as the competitions between (**88** and **92**) and (**83** and **92**) for LiClO_4 , these experiments allowed for the observation of both free ligands and both complexes. Therefore, the solution for K_{rel} is generated by knowing the relative concentrations of all four species. This makes these data more reliable than Hines' (**83** and **88**) competition experiment for LiClO_4 which was monitored by ^1H NMR resonances for **83** and $83 \cdot \text{Li}^+$. Experimental errors in weighing of samples dramatically alter the value of K_{rel} for that type of experiment. However, integration of ^1H NMR spectra is far more accurate than ^{13}C NMR spectra because of the influence of T_1 's and NOE differences in ^{13}C NMR spectra. These differences could lead to error in the data for the competitions between (**88** and **92**) and (**83** and **92**) for LiClO_4 . Clearly, some experiments must be repeated in order to confirm all of these results.

$$K_{88/92} = \frac{[88 \cdot \text{Li}^+][92]}{[92 \cdot \text{Li}^+][88]} \quad K_{83/88} = \frac{[83 \cdot \text{Li}^+][88]}{[88 \cdot \text{Li}^+][83]}$$

$$K_{83/92} = \frac{[88 \cdot \text{Li}^+][92]}{[92 \cdot \text{Li}^+][88]} \times \frac{[83 \cdot \text{Li}^+][88]}{[88 \cdot \text{Li}^+][83]} = \frac{[83 \cdot \text{Li}^+][92]}{[92 \cdot \text{Li}^+][83]} = 1.13 \times 10^4$$

(Equation 3.10)

Complexation of 1-Methyl-1,4,8,11-tetraazabicyclo[6.6.2]hexadecane (**114**) with LiClO₄ and NaClO₄ in CD₃CN.

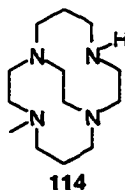

We believed that **114** may have complexing abilities for Li⁺ and Na⁺ which were superior to **92** even though **114** has a hydrogen bonded proton inside the cavity. We also believe that **114** should be less basic than **83** and other fully substituted cross-bridged cyclam derivatives. If this hypothesis is correct, and the complexation properties of **114** were relatively similar to those of **83**, **114** would be a very interesting lead for preparing “less basic” Li⁺ selective cross-bridged ligands. The 1:1 LiClO₄ complex of **114** was prepared in CD₃CN. The **114**•Li⁺ complex had thirteen distinct ¹³C resonances which are listed in Table 3.8. The NMR sample containing a 1:1 molar mixture of NaClO₄ and **114** had only twelve resonances and also displayed dynamic broadening for six of these resonances. These chemical shifts are listed in Table 3.8 This broadening is a result of exchange of Na⁺ between **114**•Na⁺ and free **114**.

Competition: LiClO₄ and NaClO₄ for 1-Methyl-1,4,8,11-tetraazabicyclo[6.6.2]hexadecane (114) in CD₃CN.

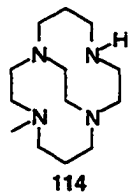

Method of Detection: ¹³C{¹H} NMR

Resonance Observed (**114**•Li⁺): 23.82 ppm (NCH₂CH₂CH₂N)

Resonance Observed ((**1:1**)**114**:NaClO₄): 25.45 ppm (NCH₂CH₂CH₂N)

Initial Concentration of a Single Amine Component: 1.34 × 10⁻¹ M

A competition was performed between Li⁺ and Na⁺ for **114** in a 1:1:1 molar ratio in CD₃CN (for sample preparation and data acquisition see Experimental Section). After inspection of the ¹H NMR spectra of **114**, **114**•Li⁺, and (**1:1**)**114**:NaClO₄ in CD₃CN, no isolated resonances which could be accurately integrated were found. Therefore, an estimate of K_{Li⁺/Na⁺} was calculated based on the line height of ¹³C NMR resonances. The ¹³C NMR resonances for **114**, **114**•Li⁺, and (**1:1**)**114**:NaClO₄ in CD₃CN are given in Table 3.8. A set of ¹³C resonances was observed which was consistent with **114**•Li⁺. There was also a minor component which was consistent with (**1:1**)**114**:NaClO₄. These resonances are also listed in Table 3.8. An estimate can be calculated for K_{Li⁺/Na⁺}, based on the height of the signals for respective carbons for the two complexes. The ratio of the peak heights was 94:6 in favor of **114**•Li⁺. The competition equilibrium constant (K_{Li⁺/Na⁺}) calculated from Equation 3.11 for this competition was estimated as 2.5 × 10²

based on these data. The free energy of competition ($\Delta\Delta G_{\text{rel}}^\circ$) was estimated to be -3.26 kcal/mol at 25 °C. 114 is a better complexer of Li^+ than Na^+ . However, it is reasonable to consider this experimental result questionable. The ^1H NMR of the competition sample clearly shows water present in a relatively large quantity. Therefore, the water must have been introduced from 114 or one or both of the perchlorate salts resulting in error in the stoichiometry of the competition. This competition should be repeated with anhydrous reagents to confirm the observed K_{rel} .

$$K_{\text{rel}} = \frac{K_{\text{Li}^+}}{K_{\text{Na}^+}} = \frac{[\text{114}\cdot\text{Li}^+][\text{Na}^+]}{[\text{114}\cdot\text{Na}^+][\text{Li}^+]} = \frac{[\text{114}\cdot\text{Li}^+]^2}{[\text{114}\cdot\text{Na}^+]^2} = \frac{[94]^2}{[6]^2} = 2.45 \times 10^2$$

(Equation 3.11)

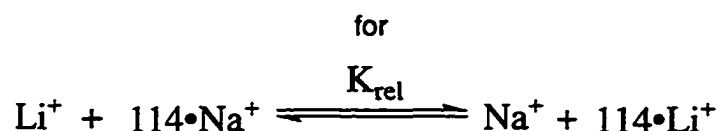

Table 3.8: ^{13}C Chemical Shifts for Complexation Experiments on 114 with LiClO_4 and NaClO_4 in CD_3CN .

114	114•Li⁺	(1:1) 114:NaClO₄	Li⁺/Na⁺ major	Competition minor
26.52	23.84	25.42	23.82	25.45
28.32	24.68	25.90	24.67	-----
41.93	43.40	43.85 (b)	43.40	43.97
49.82	45.59	44.91	45.58	-----
49.93	47.95	49.62 (b)	47.95	48.91
50.37	51.81	51.10	51.81	-----
20.59	52.16	52.04 (b)	52.18	-----
55.00	52.54	53.07 (b)	52.55	53.18
57.10	58.86	57.99 (b)	58.86	57.77
57.10	59.19	58.33 (b)	59.18	58.12
58.01	59.19	59.13	59.18	-----
59.82	59.63	59.37	59.61	-----
62.40	61.52	-----	61.50	-----

Initial Concentration of 114 in the Competition: 1.34×10^{-1} M

Competition: 1-Methyl-1,4,8,11-tetraazabicyclo[6.6.2]hexadecane (114) and 4,11-Dimethyl-1,4,8,11-Tetraazabicyclo[6.6.2]hexadecane (83) for LiClO₄ in CD₃CN.



A competition between **114** and **83** for LiClO₄ was carried out. However, too much LiClO₄ was added in this experiment which negates the possibility to calculate K_{rel} . Since the quantity of **114** on hand was relatively low, further experiments were not possible. The experiment conducted does qualitatively show that **83**•Li⁺ was the dominant complex in solution. There was **114**•Li⁺ present in the competition sample, but no free **83** was detected which verified excess LiClO₄ was present after all of the **83** had been complexed. However, **83** is a much better Li⁺ complexer than **114**.

Competition: 4,11-Bis-(2-carboethoxymethyl)-1,4,8,11-tetraazabicyclo[6.6.2]hexadecane (137) and 4,11-Bis-(N,N'-diethylacetamido)-1,4,8,11-tetraazabicyclo[6.6.2]hexadecane (95) for LiClO₄.

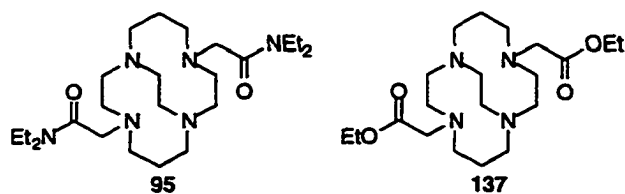

Method of Detection: ^1H NMR

Resonances Observed ($137\cdot\text{Li}^+$) and (137): 4.02-4.28 ppm (CH_2CH_3 , 8H)

Resonance Observed (95): 3.88 ppm (td, 2H)

Initial Concentration of a Single Amine Component: 4.11×10^{-2} M

In this experiment, the $137\cdot\text{Li}^+$ complex was preformed in CD_3CN and 95 was then added to this solution. This mixture was observed by ^1H NMR over 36 hours. The ^1H NMR data showed that there was a slow approach to equilibrium favoring $95\cdot\text{Li}^+$. However, for data points closer to t_{∞} it was clear that the complexation of LiClO_4 was competing with complexation of H^+ or H_2O . The water was introduced from the ligands. Water present in the sample complicated this experiment and, as a result, the relative complexation constant for these two ligands could not be calculated. This experiment must be repeated using anhydrous ligands.

Determination of Thermodynamic Mixtures Over Kinetic Mixtures in Competition

Experiments.

A necessary condition for competition experiments is that the complexation must reach thermodynamic equilibrium. We had assumed, based on work by Hill and Hines, that the rates of complexation and decomplexation of the Li^+ cation by cross-bridged ligands were relatively fast on the laboratory time scale. That is to say, kinetic mixtures of complexes and free ligands were not observed and thermodynamic equilibrium had been reached by the time the NMR sample had been prepared, the NMR experiment setup and

the spectrum acquired. Ideally, to verify this condition, two separate experiments must be carried out. For a ligand-ligand-metal competition, a 1:1 complex with one ligand (Ligand A) and the metal is preformed and one equivalent of the second ligand (Ligand B) is added. The NMR experiment is performed and the K_{rel} is calculated. In a second experiment, a 1:1 complex is preformed with the other ligand (Ligand B) and the metal and one equivalent of the complementary ligand (Ligand A) is added. The K_{rel} for this experiment should be the same if both samples have reached thermodynamic equilibrium. Unfortunately, we could not perform the analysis in this manner due low quantity of ligands. Therefore, we have indirectly proven that the competitions reported in this chapter had come to thermodynamic equilibrium.

The competition of **92** and **88** for Li^+ resulted in a $\Delta\Delta G_{rel}^\circ$ of -0.347 kcal/mol. If this is a thermodynamic result, **92** and **88** complex Li^+ approximately equally. The introduction of one equivalent of **95**, a much stronger Li^+ complexer, should result in all of **95** complexed with Li^+ to afford **95**• Li^+ and free **92** and free **88**. In fact, this was exactly what was observed experimentally within 20 minutes after the addition of **95** to the mixture of **92**, **88**, **92**• Li^+ and **88**• Li^+ . The same experiment was conducted using the competition experiment between **92** and **83**. Within 20 minutes after the addition of **95** to the mixture of **92**, **83**, **92**• Li^+ and **83**• Li^+ , no free **95** was detected. These two experiments prove that there is rapid equilibration between Li^+ -complexed cross-bridged ligands and thermodynamic equilibrium is quickly achieved in these cases.

Further experiments were conducted on the competition of **95** and **83** for $LiClO_4$.

As stated previously, the experimental result of this competition did not provide any evidence for presence of $83\cdot\text{Li}^+$ in that sample. However, it was possible that in the sample preparation, $95\cdot\text{Li}^+$ was formed before the addition of **83**. If that was the case, the observed ^{13}C NMR spectrum for this competition may be of a kinetic mixture of **83**, **95** and LiClO_4 . To prove that this was not a kinetic mixture, another equivalent of LiClO_4 was added to the competition NMR sample to afford a mixture of $83\cdot\text{Li}^+$ and $95\cdot\text{Li}^+$. It was confirmed, by ^{13}C NMR, that these were the only two species present in this sample. Another equivalent of free **95** was then added. Since the only source of Li^+ available for free **95** to complex is from $83\cdot\text{Li}^+$, the relative complexing abilities of **95** and **83** for Li^+ can be directly observed. ^{13}C NMR analysis of the resulting mixture was consistent with **83** and $95\cdot\text{Li}^+$, verifying that **95** is a better complexer of Li^+ than **83** as previously observed. Furthermore, this spectrum was run within twenty minutes after the addition of the second equivalent of **95**. Therefore, thermodynamic equilibrium was established quickly on the laboratory time scale in the competition of **95** and **83** for LiClO_4 .

Complexation of Cross-Bridged Cyclam Derivatives with Cu^{2+} .

Weisman, Wong and coworkers reported the preliminary results of complexation of cross-bridged cyclam derivatives with Cu^{2+} .¹⁰⁴ Included in this publication was the Cu^{2+} complex of **138** was prepared by Wong and its x-ray crystal structure. The $[\text{Cu}(\mathbf{96})(\text{ClO}_4)_2]$ complex has been prepared and gave satisfactory elemental analysis. Unfortunately, crystals of sufficient quality of the Cu^{2+} complex of the new amide armed

Chapter IV

EXPERIMENTAL SECTION

I. General Methods

Melting points (mp) were recorded on a Thomas Hoover capillary melting point apparatus and are uncorrected.

Infrared spectra (IR) were run on a Nicolet MX-1 FT-IR spectrometer and absorptions are reported in wavenumbers (cm^{-1}).

^1H NMR spectra (^1H NMR) were acquired on a Bruker AM360 FT-NMR spectrometer operating at 360.134 MHz. Chemical shift (δ) values are reported in parts per million (ppm) relative to Me_4Si (TMS) unless otherwise noted. Coupling constants (J values) are reported in Hertz (Hz).

^{13}C NMR spectra (^{13}C NMR) were acquired on a Bruker AM360 FT-NMR spectrometer operating at 90.556 MHz. Chemical shift (δ) values are reported in parts per million (ppm) relative to Me_4Si (TMS) unless otherwise noted. In those cases, chemical shifts are either referenced to a secondary reference or a known resonance for the deuterated solvent.

Low resolution mass spectra (MS) were performed by the University of New Hampshire Instrumentation Center on a Hitachi-Perkin-Elmer RMU-60 mass spectrometer. The methods of ionization (EI or CI) are given in the individual experiments.

Elemental analyses were performed by the University of New Hampshire Instrumentation

Center on a Perkin-Elmer 240B elemental analyzer.

Ultraviolet-visible spectra (UV-Vis) were acquired on a Varian Cary 5 spectrophotometer and absorptions are reported in nanometers (nm).

II. Solvents

Absolute ethanol (EtOH) was obtained for routine use from AAEPR Alcohol and Chemical Co. This product was also distilled from Mg and stored over 3Å molecular sieves for special applications.

Acetone (reagent grade) was obtained from Fisher Chemical Co. and was used without further purification.

Acetonitrile (CH₃CN) was obtained from EM Science and distilled from CaH₂ prior to use.

Benzene (C₆H₆) was obtained from J.T. Baker and distilled prior to use.

Chloroform (CHCl₃) was obtained from EM Science and distilled from CaH₂ prior to use.

Diethylether (Et₂O) was obtained from Fisher Chemical Co. and was distilled from benzophenone-ketyl prior to use.

Dimethylformamide (DMF) was obtained from J.T. Baker and distilled under reduced pressure (water aspirator) from CaH₂ prior to use.

Deuterated NMR solvents were obtained from Cambridge Isotope Laboratories and stored over 3Å molecular sieves.

Ethanol (95% EtOH) was obtained from AAEPR Alcohol and Chemical Co.

Glacial acetic acid (HOAc) was obtained from Fisher Chemical Co.

Hexanes were obtained from Pharmco Chemical Co. and were fractionally distilled prior to use and stored over 3Å molecular sieves.

Methanol (MeOH) was obtained from Fisher Chemical Co. It was distilled and stored over 3Å molecular sieves.

Methylene chloride (CH₂Cl₂) was obtained from J.T. Baker and distilled from CaH₂ prior to use.

Tetrahydrofuran (THF) was obtained from Fisher Chemical Co. and was distilled from benzophenone-ketyl prior to use.

Toluene (PhCH₃) was obtained from EM Science and was distilled from Na^o prior to use and stored over 3Å molecular sieves.

III. Reagents

Acrylamide was obtained from Aldrich chemical Co.

Acrylonitrile was obtained from Aldrich Chemical Co.

Aluminum chloride was obtained from Aldrich Chemical Co.

N-(2-Aminoethyl), N'-(3-aminopropyl)-1,2-diaminoethane tetrahydrochloride was obtained from Aldrich Chemical Co.

Benzyl bromide (PhCH_2Br) was obtained from Aldrich Chemical Co.

Borane-tetrahydrofuran complex ($\text{BH}_3 \cdot \text{THF}$) was obtained from Aldrich Chemical Co. as a 1M solution in THF.

Bromine was obtained from Aldrich Chemical Co.

Bromoethane was obtained from Aldrich Chemical Co.

Bromobutane was obtained from Aldrich Chemical Co.

p-Bromo-nitrobenzene was obtained from J.T. Baker.

p-Bromotoluene was obtained from Aldrich Chemical Co.

2-Chloroacetamide was obtained from Aldrich Chemical Co.

2-Chloro-N,N'-diethylacetamide was obtained from Aldrich Chemical Co.

N,N'-Bis-(2-aminoethyl)-1,3-propanediamine was obtained from Aldrich Chemical Co.

N,N'-Bis-(3-aminopropyl)-ethylenediamine was obtained from Aldrich Chemical Co.

N,N'-Bis-(3-aminopropyl)-1,3-propanediamine was obtained from Aldrich Chemical Co.

Racemic-2,2'-Bis(diphenylphosphino)-1,1'-binaphthyl (\pm BINAP) was obtained from

Strem Chemical Co.

Celite (Diatomaceous Earth Powder) was obtained from VWR Scientific Co.

Cupric acetate hexahydrate was obtained from J.T. Baker.

Cupric chloride hexahydrate was obtained from Aldrich Chemical Co.

Cupric perchlorate hexahydrate was obtained from Aldrich Chemical Co.

1,2-Dibromoethane was obtained from Aldrich Chemical Co.

α,α' -Dibromo-*o*-xylene was obtained from Aldrich Chemical Co.

Diethyloxalate was obtained from Aldrich Chemical Co.

Diisobutylaluminumhydride (DIBALH) was obtained as a 1.5 M solution in toluene from Aldrich Chemical Co.

Dimethylene bis(*p*-toluenesulfonate) was prepared by C.A. West.

1,8-Dimethyl-1,4,8,11-tetraazabicyclo[6.6.2]tetradecane was graciously provided by M. S. Hines.

2,4-Dinitrofluorobenzene was obtained from Aldrich Chemical Co.

Dithiooxamide was obtained from Fluka Chemical Co.

Ethanolamine was obtained from Aldrich Chemical Co.

Ethylbromoacetate was obtained from Aldrich Chemical Co.

Ethylenediamine was obtained from Aldrich Chemical Co. and was distilled from KOH prior to use.

Glyoxal (40 wt % aq. solution) was obtained from Aldrich Chemical Co.

1,3,4,6,7,8-Hexahydro-2H-pyrimido[1,2'-a]pyrazine was obtained from Aldrich Chemical

Co.

Hexamethyldisilazane was obtained from Aldrich Chemical Co.

Hydrochloric acid (12 M HCl) was obtained from Fisher Chemical Co. and was used without further purification.

Hydrogen (prepurified grade) was obtained from Northeast Air Gas.

Hydroxylamine hydrochloride was obtained from Aldrich Chemical Co.

Lithium aluminum hydride (LiAlH_4) was obtained from Aldrich Chemical Co.

Lithium perchlorate (LiClO_4) was obtained from J.T. Baker.

Methyl iodide (MeI) was obtained from Aldrich Chemical Co.

Molybdenum hexacarbonyl was graciously supplied by E. H. Wong.

Oxalic acid was obtained from Aldrich Chemical Co.

Oxamide was obtained from Aldrich Chemical Co.

10% Palladium on carbon (10% Pd/C) was obtained from Aldrich Chemical Co.

1,2-Phenylenediamine was obtained from Aldrich Chemical Co.

N-Phenylmaleimide was obtained from Aldrich Chemical Co.

Potassium *tert*-butoxide was obtained from J.T. Baker.

Potassium carbonate (K_2CO_3) was obtained from Fisher Chemical Co.

Potassium hydroxide (KOH) was obtained from Fisher Chemical Co.

Potassium iodide (KI) was obtained from Fisher Chemical Co.

1,3-Propanediamine was obtained from Aldrich Chemical Co. and was distilled from KOH prior to use.

Sodium borohydride (NaBH_4) was obtained from Aldrich Chemical Co.

Sodium hydride (NaH) was obtained as a 57% mineral oil dispersion from Aldrich Chemical Co.

Sodium perchlorate (NaClO_4) was obtained from Aldrich Chemical Co.

Sodium sulfate (Na_2SO_4 , anhydrous) was obtained Fisher Chemical Co.

Sodium tetrphenylborate (NaBPh_4) was obtained from J.T. Baker.

Tetrakis-(dimethylamino)-ethylene was obtained from Aldrich Chemical Co.

p-Toluenesulfonic acid was purchased from Aldrich Chemical Co.

p-Toluenesulfonyl chloride was purchased from Aldrich Chemical Co.

1.4.8.11-Tetraazacyclotetradecane (cyclam) was obtained from Strem Chemical Co.

Triethylenetetraamine was purchased from Fluka Chemical Co. as either the pure tetraamine or a 70% wt% crude mixture (GC analysis) and used without further purification.

Alternatively, the pure tetraamine could be generated from triethylenetetraamine hydrate which was obtained from Aldrich Chemical Co. The tetraamine was obtained following azeotropic distillation of the monohydrate with toluene for 3 days. Removal of the toluene by rotary evaporation afforded the anhydrous tetraamine.

Trifluoroacetic acid (CF_3COOH) was obtained from Aldrich Chemical Co. and was distilled from trifluoroacetic anhydride prior to use.

Trimethylene bis(p-toluenesulfonate) was prepared by S.W. North.

Tris(dibenzylideneacetone)-dipalladium(0) ($\text{Pd}_2(\text{dba})_3$) was obtained from Aldrich Chemical Co.

IV. Syntheses

Note: All routine solvent evaporations were carried out on a standard rotary evaporator using aspirator pressure unless otherwise noted. All reactions were carried out under a N₂ atmosphere unless otherwise noted.

Reaction of Triethylenetetraamine and Glyoxal. Triethylenetetraamine (1.10 g, 7.51 mmol) was dissolved in CH₃CN (25 mL) in a 100 mL round bottomed flask. Glyoxal (1.09 g; 40 wt % aq. solution, 7.5 mmol) was added in one portion. This mixture was stirred at reflux under N₂ for 17 h. The reaction mixture was concentrated by rotary evaporation. The residue was taken up in CHCl₃ (50 mL), dried over Na₂SO₄ and the filtrate was concentrated to afford a brown oil. ¹³C NMR analysis of this oil is consistent with a mixture of isomeric bisaminals. The major component was identified as *cis*-**13** having chemical shifts consistent with results published by Jazwinski.⁴⁶ ¹³C NMR (CDCl₃, 90.56 MHz, ref central line of CDCl₃ set at 77.23) δ 41.79 br, 50.06 br (2 C's), 65.44, 76.57. The remaining resonances were not assigned but could be a mixture of the other three possible bisaminal isomers (*trans*-**13**, *cis*-**14**, *trans*-**14**): δ 38.25, 43.45, 44.47, 47.97, 49.43, 50.74, 52.15, 52.77, 60.59, 70.70, 75.86, 79.28, 87.04.

2,3,5,6,8,9-Hexahydrodiimidazo[1,2-a:2',1'-c]pyrazine (16). A 500 mL three-necked round-bottom flask equipped with a reflux condenser with a nitrogen inlet tube, pressure-equalized addition funnel, fritted gas dispersion tube (initially closed) and a

magnetic stirrer was charged with dithiooxamide (10.00 g, 83.19 mmol) and absolute ethanol (50 mL). The nitrogen manifold exit line was routed through two fritted gas washing bottles charged with 30% aqueous NaOH in order to trap H₂S evolved. A solution of triethylenetetraamine (12.16 g, 83.15 mmol) in absolute ethanol (50 mL) was introduced to the reaction flask in one portion via the addition funnel. The mixture was then heated for 4 hours at reflux under nitrogen with the evolution of H₂S and NH₃. The reaction mixture was then cooled to room temperature and residual H₂S and NH₃ were purged from the solution by entrainment with nitrogen, which was bubbled through the mixture from the fritted gas dispersion tube for 3 hours. The solvent was then removed by short path vacuum distillation (water aspirator) and the residue taken up in CHCl₃ (150 mL). Insoluble material was removed by gravity filtration through a glass wool plug inserted in a short stem funnel. The solvent was then removed by rotary evaporation under reduced pressure to give 14.18 g of crude product. This solid was taken up in 50 mL of boiling toluene and filtered through another glass wool plug. The flask was rinsed with a second aliquot of boiling toluene which was poured through the funnel. The combined filtrates were concentrated by rotary evaporation to afford 13.66 g of yellow solid. Sublimation of this material (0.03 Torr, 110° C) afforded 10.58 g (77.5%) of product which was of sufficient purity for conversion to cyclen. If desired, it can be further purified by sublimation (100°C, 0.01 Torr): white solid; mp 150-151°C; ¹H NMR (CDCl₃, 360.15 MHz, TMS) δ 3.25 (s, 4H), 3.34 (apparent t (XX' of AA'XX'), 4H, J_{appar} = 9.6 Hz), 3.86 (apparent t (AA' of AA'XX'), 4H, J_{appar} = 9.6 Hz); ¹³C NMR (CDCl₃, 90.56 MHz,

ref central line of CDCl_3 set at 77.23) δ 45.40, 52.17, 54.16, 155.50; IR (KBr) 1629 cm^{-1} (C=N); MS (EI) 164.15 M^+ ; Anal. Calcd for $\text{C}_8\text{H}_{12}\text{N}_4$: C, 58.52; H, 7.37; N, 34.12. Found: C, 58.38; H, 7.55; N, 34.22.

Attempted Alkylation of Dithiooxamide with Bromoethane. Experiments were performed in order to verify that bromoethane does not alkylate dithiooxamide under the reaction conditions employed in the preparation of **17**. Results of NMR experiments were compared to NMR spectra of authentic samples of dithiooxamide and bromoethane run in $\text{EtOD-}d_6$ and $\text{DMSO-}d_6$.

1.) Dithiooxamide (1.00 g, 8.32 mmol) was suspended in EtOH (10 mL). Bromoethane (10 mL, mmol) was added to this slurry by syringe. This heterogeneous mixture was heated at $60\text{ }^\circ\text{C}$ under N_2 for 7 h. The reaction mixture was then concentrated by short path vacuum distillation (water aspirator). Under a N_2 atmosphere, a small sample was removed from the reaction flask and residual solvent was removed under vacuum. NMR spectra were consistent with dithiooxamide and no alkylation was observed. Elemental analysis of this sample also verified dithiooxamide as the only product. Anal. Calcd for $\text{C}_2\text{H}_4\text{N}_2\text{S}_2$: C, 19.99; H, 3.35; N, 23.31; Found: C, 19.70; H, 3.21; N, 22.97.

2.) Dithiooxamide (1.00 g, 8.32 mmol) was placed in an Ace pressure tube. Bromoethane (1.3 mL, 17.4 mmol) was added by syringe followed by enough EtOH (~18 mL) to leave only approximately 1 cm of head space in the pressure tube. This mixture was heated at $70\text{ }^\circ\text{C}$ for 1.5 h. At this time all of the solid had dissolved except for the small area of the

pressure tube which was not submerged in the oil bath. Upon cooling to room temperature an orange solid precipitated from the solution. The pressure tube was opened (cautiously) in a dry bag which had been flushed with N₂. There was no noticeable gas evolution when the pressure tube was opened. A portion of the supernatant was removed by syringe and placed in a Schlenk flask equipped with a short path distillation head. The solvent was removed by vacuum distillation (water aspirator). NMR analysis of the pot residue from the distillation was consistent with dithiooxamide and no alkylation was observed: ¹H NMR (DMSO-*d*₆, 360.15 MHz, TMS) δ 9.59 (br s, 2H), 10.15 (br s, 2H).

3.) Dithiooxamide (0.0564 g, 0.4691 mmol) was suspended in EtOD-*d*₆ (1.0 mL).

Bromoethane (350 μL, 4.68 mmol) was added by syringe. This mixture was heated at 60 °C for 3.5 h under N₂. The supernatant was removed by syringe and transferred to an NMR tube under N₂. The ¹H NMR data was consistent with bromoethane as the only species in solution: ¹H NMR (EtOD-*d*₆, 360.15 MHz, TMS) δ 1.63 (t, 3H, CH₃CH₂Br), 3.40 (q, 2H, CH₃CH₂Br). The solid remaining in the reaction flask was dissolved in DMSO-*d*₆ and also transferred to an NMR tube by syringe under N₂. ¹H NMR data was consistent with dithiooxamide and bromoethane. No evidence for alkylation of dithiooxamide by bromoethane was found: ¹H NMR (DMSO-*d*₆, 360.15 MHz, TMS) δ 1.58 (t, 3H, CH₃CH₂Br), 3.49 (q, 2H, CH₃CH₂Br), 9.58 (br s, 2H, NH), 10.19 (br s, 2H, NH).

1,4,7,10-Tetraazacyclododecane (Cyclen) (2). A 1 L three-necked

round-bottomed flask equipped with a reflux condenser with a nitrogen inlet tube, pressure-equalized addition funnel and magnetic stirrer was charged with 2,3,5,6,8,9-hexahydroimidazo[1,2-a:2',1'-c]pyrazine (**16**) (10.58 g, 64.43 mmol). The system was flushed with N₂ prior to the introduction of a 1.5 M solution of DIBALH in toluene (250 mL, 375 mmol) to the addition funnel by cannulation. The reaction flask was cooled in an ice/H₂O bath and the DIBALH solution was introduced to the reaction flask dropwise over 5 minutes. The reaction mixture was then heated at reflux under nitrogen for 16 h. The reaction flask was again cooled in an ice/H₂O bath prior to the addition of toluene (200 mL). The reaction was quenched by the cautious drop-wise addition of a 3 M NaOH solution (20 mL). When gas evolution had ceased, 355 mL of 3 M NaOH was added in one portion and the two phase mixture was transferred to a separatory funnel. After the layers were separated, ice chips were added to the aqueous layer and it was extracted with CHCl₃ (6×150 mL) which had been cooled in an ice/H₂O bath. The combined organic extracts were dried over Na₂SO₄ and the solvent removed by rotary evaporation to afford 10.22 g of white crystalline solid. Sublimation (0.4 Torr, 90 °C) of this white solid afforded 9.77 g (88.6 %) of cyclen: mp 103-107 °C (lit mp¹⁴⁷); ¹H NMR (C₆D₆, 360.15 MHz, TMS) δ 1.60 (s, 4H), 2.45 (s, 16H). ¹³C NMR (C₆D₆, 90.56 MHz, ref central line of C₆D₆ set at 128.39) δ 46.99.

2,3,4,5,5a,6,7,8-Octahydro-1,3a,5,9-tetraazabenzindene (18). A 250 mL three-necked round-bottom flask equipped with a reflux condenser with a nitrogen inlet

tube, fritted gas dispersion tube (initially closed) and a magnetic stirrer was charged with (2.05 g, 16.8 mmol) of dithiooxamide and 20 mL of absolute ethanol. The nitrogen manifold exit line was routed through two fritted gas washing bottles charged with 30% aqueous NaOH in order to trap H₂S evolved. 1,4,7,11-Tetraazaundecane (2.74 g, 17.1 mmol) was introduced to the reaction flask in one portion followed by EtOH (5 mL), which was used to rinse the vessel containing the tetraamine. The mixture was then heated for 4 hours at reflux under nitrogen with the evolution of H₂S and NH₃. The reaction mixture was then cooled to room temperature and residual H₂S and NH₃ were purged from the solution by entrainment with nitrogen, which was bubbled through the mixture from the fritted gas dispersion tube for 2 h. The solvent was then removed by short path vacuum distillation (water aspirator) and the residue was taken up in CHCl₃ (100 mL). Insoluble material was removed by gravity filtration through a glass wool plug inserted in a short-stem glass funnel. The solvent was then removed by rotary evaporation under reduced pressure. The residue was taken up in 50 mL of boiling toluene and filtered through another glass wool plug. The flask was rinsed with a second aliquot of boiling toluene which was poured through the funnel. The combined filtrates were concentrated by rotary evaporation to afford 2.33 g of crude product. Sublimation of this material (0.2 Torr, 100 °C) afforded 1.74 g (58.2%) of product: mp: 117.5-119 °C; ¹H NMR (CDCl₃, 360.15 MHz, TMS) δ 1.89 (p, 2H, *J* = 5.8 Hz, CH₂CH₂CH₂), 3.16-3.39 (m, 2H), 3.22 (t, 2H, XX' of AA'XX', *J* = 5.8 Hz), 3.29-3.35 (m, 2H), 3.33 (t, 2H, XX' of AA'XX', *J* = 9.4 Hz), 3.55 (t, 2H, *J* = 5.7 Hz, CH₂CH₂CH₂N=C), 3.78 (t, 2H, *J* = 9.4 Hz, AA' of

AA'XX', CH₂CH₂N=C); ¹³C NMR (CDCl₃, 90.56 MHz, ref. central line of CDCl₃ set at 77.23) δ 21.35 (CH₂CH₂CH₂), 44.78, 45.15, 47.37, 48.42, 53.27, 53.53, 145.59, 158.66; IR (KBr) 1629, 1604 cm⁻¹; MS (EI) *m/z* 178.3 M⁺; Anal. Calcd for C₉H₁₄N₄: C, 60.65; H, 7.92; N, 31.43. Found: C, 60.25; H, 8.09. N, 31.80.

1,4,7,11-Tetraazacyclotridecane (19). A 50 mL three-necked round-bottomed flask equipped with a reflux condenser with a nitrogen inlet tube and magnetic stirrer was charged with 2,3,4,5,5a,6,7,8-octahydro-1,3a,5,9-tetraazabenzindene (**18**) (1.05 g, 5.89 mmol). The reaction flask was cooled in an ice/H₂O bath and the system was flushed with N₂ prior to the introduction of a 1.5 M solution of DIBALH in toluene (24 mL, 36 mmol) by syringe. The reaction mixture was then heated at reflux under nitrogen for 16 h. The reaction flask was again cooled in an ice/H₂O bath prior to the addition of 20 mL of toluene. The reaction was quenched by the cautious dropwise addition of a 3 M NaOH solution (36 mL). After the layers were separated, ice chips were added to the aqueous layer and it was extracted (6×25 mL) with CHCl₃ which had been cooled in an ice/H₂O bath. The combined organic extracts were dried over Na₂SO₄ and the solvent removed by rotary evaporation to afford 1.12 g of crude product. Sublimation (0.05 Torr, 80 °C) of this material afforded 0.979 g (89.3%) of crystalline product: mp: 39-40 °C (lit.⁷¹ 40-41 °C) ¹H NMR (CDCl₃, 360.15 MHz, TMS) δ 1.68 (p, 2H, CH₂CH₂CH₂), 2.13 (br s, 4H, NH), 2.66-2.77 (m, 16H); ¹³C NMR (CDCl₃, 90.53 MHz, ref. central line of CDCl₃ set at 77.23) δ 29.25, 47.71, 47.93, 49.18, 50.16. NMR spectra were consistent with

reported spectra.⁷⁰

2,2'-Bihexahydropyrimidine (20). This compound was prepared by the method of Jazwinski.⁴⁵ 1,3-Propanediamine (4.13 g, 55.8 mmol) was placed in a round-bottomed flask followed by aqueous glyoxal (1.32 g; 40 wt % aq. solution, 23.6 mmol). This mixture was heated at 70 °C under N₂ for 3 h. The reaction mixture was then concentrated, dissolved in CHCl₃ and dried over Na₂SO₄. Concentration of the filtrate afforded a yellow solid which was recrystallized from CH₃CN to afford 1.45 g (37%) of product.

Sublimation of the product is possible with loss of some material to decomposition: mp: 121-126 °C (lit.⁴⁵: 129-130 °C); ¹H NMR (CDCl₃, 360.15 MHz, TMS) δ 1.43-1.60 (m, 4H, CH₂CH₂CH₂), 1.65 (br s, 4H, NH), 2.78 (ddd, 4H, *J* = 15.6, 13.4, 3.4 Hz, NCH_{ax}HCH₂), 3.15 (ddd, 4H, *J* = 13.4, 4.3, 4.1 Hz, NCHH_{eq}CH₂), 3.38 (s, 2H, NCHN); ¹³C NMR (90.56 MHz, CDCl₃, ref central line of CDCl₃ set at 77.23) δ 27.76, 45.73, 74.40. Spectra were consistent with reported data.⁴⁵

Trans-4a,4b-perhydro-4,5,8a,10a-tetraazaphenanthrene (21). This compound was prepared by the method of Jazwinski.⁴⁵ 2,2'-Bihexahydropyrimidine (20) (1.75 g, 10.3 mmol) was suspended in H₂O (75 mL) in a 250 mL round-bottomed flask. Aqueous glyoxal (1.5 mL, 40 wt % aq. solution, 11 mmol) was added in one portion and the resulting mixture was stirred under N₂ for 24 hours. NaBH₄ (1.2 g, 32 mmol) was then added in small portions and this slurry was stirred at room temperature for 3 days. NaOH

pellets were added to increase the pH to 14 and this solution was continuously extracted with toluene for 3 days. The organic layer was dried over Na_2SO_4 and concentrated to afford 1.88 g (93%) of product. ^{13}C NMR analysis of this material was consistent with a mixture of *cis* and *trans* isomers of **21**. The ratio of *trans* to *cis* was 80:20 based on the height of respective ^{13}C NMR lines: ^{13}C NMR (CDCl_3 , 90.56 MHz, ref central line of CDCl_3 set at 77.23) δ 26.6, 44.9, 52.6, 54.7, 79.3 (*trans*); δ 27.1, 44.8, 52.8, 54.0, 59.2, 74.5 (*cis*); MS (EI) m/z 196.2 M^+ . Fractional recrystallization of this material from hexane afforded the pure *trans* isomer: mp: 102.5-104 °C (lit⁴⁵: 102.5-104 °C); ^1H NMR (CDCl_3 , 360.15 MHz, TMS) δ 1.51-1.58 (dm, 2H, $J = 13.1$ Hz, $\text{NCH}_2\text{CHH}_{eq}\text{CH}_2\text{N}$), 1.78 (qt, 2H, $J = 12.8, 4.6$ Hz, $\text{NCH}_2\text{CHH}_{ax}\text{CH}_2\text{N}$), 1.85 (br s, 2H), 2.20 (td, 2H, $J = 11.9, 3.1$ Hz), 2.35-2.48 (m, 2H, XX' of AA'XX', $\text{NCH}_2\text{CH}_2\text{N}$), 2.61 (td, 2H, $J = 12.8, 3.1$ Hz), 2.58 (s, 2H, NCHN), 2.60-2.68 (m, 2H, AA' of AA'XX', $\text{NCH}_2\text{CH}_2\text{N}$), 2.91-2.96 (dm, 2H, $J = 9.1$ Hz), 3.09-3.14 (dm, 2H, $J = 12.8$ Hz); ^{13}C NMR (CDCl_3 , 90.56 MHz, ref central line of CDCl_3 set at 77.23) δ 26.6, 44.9, 52.6, 54.7, 79.3. Spectra were consistent with reported data.⁴⁵

Reduction of *trans/cis*-4a,4b-perhydro-4,5,8a,10a-tetraazaphenanthrene

(**21**). A 100 mL three-necked round-bottomed flask equipped with a reflux condenser and a N_2 inlet tube was charged with *trans/cis*-4a,4b-perhydro-4,5,8a,10a-tetraazaphenanthrene (**21**) (0.2387 g, 1.216 mmol). DIBALH (1.5 M in toluene, 12 mL, 18 mmol) was added via syringe under N_2 . This mixture was heated at reflux for 4 d. The reaction mixture was

then cooled to room temperature and diluted with toluene (25 mL). NaF (12 g, 280 mmol) and H₂O (1.5 mL, 83 mmol) were then added in small portions. The solids were isolated by vacuum filtration and washed with CHCl₃ (3×10 mL). The filtrates were combined, dried over Na₂SO₄ and concentrated by rotary evaporation to afford 0.1961 g of a crystalline product. NMR analysis of this solid showed that the major component in the reaction product mixture was *trans* 4a,4b-perhydro-4,5,8a,10a-tetraazaphenanthrene (*trans*-21). The *cis* isomer (*cis*-21) was not observed: ¹H NMR (CDCl₃, 360.15 MHz, TMS) δ 1.51-1.56 (dm, 2H, *J* = 13.1 Hz, NCH₂CHH_{eq}CH₂N), 1.77 (qt, 2H, *J* = 12.8, 4.6 Hz, NCH₂CHH_{ax}CH₂N), 2.19 (td, 2H, *J* = 11.9, 3.1 Hz), 2.37-2.48 (m, 2H, XX' of AA'XX', NCH₂CH₂N), 2.61 (td, 2H, *J* = 12.8, 3.1 Hz), 2.57 (s, 2H, NCHN), 2.60-2.68 (m, 2H, AA' of AA'XX', NCH₂CH₂N), 2.90-2.96 (dm, 2H, *J* = 9.1), 3.09-3.14 (dm, 2H, *J* = 12.8); ¹³C NMR (CDCl₃, 90.56 MHz, ref central line of CDCl₃ set at 77.23) δ 26.61, 45.00, 52.62, 54.78, 79.32. (There was also an impurity (~5% based on ¹³C line heights) observed in this spectrum) This material corresponded to 82% of the starting material. The reaction solids were placed in a Soxhlet extraction cup and were extracted with toluene for 5 h. The toluene extracts were dried over Na₂SO₄ and concentrated by rotary evaporation to afford 0.0568 g (23%) of a sticky solid. The ¹H NMR spectrum of this solid was consistent with that of an authentic sample of cyclam: ¹H NMR (CDCl₃, 360.15 MHz, TMS) δ 1.65 (p, 4H, *J* = 5.1 Hz, NCH₂CH₂CH₂N), 2.23 (br s, 4H, NH), 2.60 (s, 8H, NCH₂CH₂N), 2.67 (t, 8H, *J* = 5.2 Hz, NCH₂CH₂CH₂N).

2,3,4,6,7,9,10,11-Octahydropyrazino[1,2-a:4,3-a']dipyrimidine (23). A 100 mL three-necked round-bottomed flask equipped with a reflux condenser with N₂ inlet tube and a fritted gas dispersion tube (initially closed) was charged with dithiooxamide (0.2821 g, 2.347 mmol) suspended in EtOH (5 mL). Bromoethane (2 mL) was added and the slurry was heated at 62 °C for 3 h. The solvent was then removed by short path vacuum distillation (aspirator pressure). EtOH (10 mL) was added and the solvent was again concentrated by distillation. The residue was suspended in EtOH (4 mL) prior to the addition of a solution of bis-(3-aminopropyl)-1,2-ethylenediamine (0.4115 g, 2.361 mmol) in EtOH (2 mL) by syringe. The nitrogen manifold exit line was routed through two fritted gas washing bottles charged with 10% aqueous H₂O₂ in order to trap the gases evolved. The reaction mixture was heated at 80 °C for 2 h. The reaction mixture was then cooled to room temperature and EtOH (20 mL) was then added. Residual gaseous byproducts were purged from the solution by entrainment with nitrogen, which was bubbled through the mixture from the fritted gas dispersion tube for 15 hours. The reaction mixture was concentrated by rotary evaporation to afford 0.5966 g of crude product. A portion of this material was placed in a round-bottomed flask with toluene (5 mL) and heated. When the mixture began to boil the heat was removed. The solvent was removed by pipette while hot and concentrated by rotary evaporation to afford an oil. NMR and MS analysis determined the oil to be a mixture of **23** and **24**. ¹H NMR (CDCl₃, 360.15 MHz, TMS) for **23**: δ 1.85 (p, 4H, CH₂CH₂CH₂, *J* = 5.8 Hz), 3.21-3.50 (m, 4H, NCH₂CH₂CH₂N=), 3.27 (s, 4H, CH₂CH₂), 3.57 (m, 4H, NCH₂CH₂CH₂N=); for **24**: δ 1.8 (br s, 2H, NH₂), 1.72

(m, 2H, $\text{NCH}_2\text{CH}_2\text{CH}_2\text{N}=\text{}$, $J = 6.7$ Hz), 1.85 (p, 2H, $\text{NCH}_2\text{CH}_2\text{CH}_2\text{NH}_2$), 2.72 (t, 2H, CH_2NH_2 , $J = 6.6$ Hz), 3.21-3.28 (m, 2H), 3.47-3.60 (m, 8H). ^{13}C NMR (CDCl_3 , 90.56 MHz, ref. central line of CDCl_3 at δ 77.23) for **23**: δ 21.32 ($\text{NCH}_2\text{CH}_2\text{CH}_2\text{N}=\text{}$), 44.61, 47.56, 48.00, 147.76; for **24**: δ 21.23 ($\text{NCH}_2\text{CH}_2\text{CH}_2\text{N}=\text{}$), 30.79 ($\text{NCH}_2\text{CH}_2\text{CH}_2\text{NH}_2$), 39.05, 45.06, 45.10, 45.16, 46.92, 47.44, 147.80, 152.72. MS (EI) for **23**: m/z 192.3 M^+ ; for **24**: m/z 211.3 $\text{M}+1$. The remainder of the crude mixture of **23** and **24** was treated similarly with boiling toluene. The toluene extracts were azeotropically distilled for 3 days using a Dean-Stark trap. Concentration of the solvent afforded **23** as an impure oil: ^1H NMR (CDCl_3 , 360.15 MHz, TMS) δ 1.85 (p, 4H, $J = 6.1$ Hz, $\text{NCH}_2\text{CH}_2\text{CH}_2\text{N}=\text{}$), 3.21 (t, 4H, $J = 6.1$ Hz, $\text{NCH}_2\text{CH}_2\text{CH}_2\text{N}=\text{}$), 3.22 (s, 4H, $\text{NCH}_2\text{CH}_2\text{N}$), 3.54 (t, 4H, $J = 5.8$ Hz, $\text{NCH}_2\text{CH}_2\text{CH}_2\text{N}=\text{}$); ^{13}C NMR (CDCl_3 , 90.56 MHz, ref. central line of CDCl_3 at δ 77.23) δ 21.50, 44.96, 47.64, 48.04, 148.02. This sample was estimated to be approximately 90% pure by ^1H NMR integration. This material corresponded to an overall yield of 25%.

1,4-Bis-(3-aminopropyl)-2,3-piperazinedione (25). The crude mixture of **23** and **24** was dissolved in D_2O . NMR analysis was consistent with 1,4-bis-(3-aminopropyl)-2,3-piperazinedione (**25**). ^1H NMR (D_2O , 360.15 MHz, 2° ref CH_3CN set at 2.05) δ 1.74 (p, 4H), 2.62 (t, 4H), 3.49 (t), 3.65 (s, 4H); ^{13}C NMR (D_2O , 90.56 MHz, 2° ref CH_3CN set at 1.7) δ 29.85, 38.65, 44.83, 46.04, 159.20. This NMR sample was concentrated by rotary evaporation. EtOH (2 mL) was added and concentrated

by rotary evaporation to ensure the removal of residual D₂O. NMR of this sample in CDCl₃ was consistent with 1,4-bis-(3-aminopropyl)-2,3-piperazinedione (**25**) and **24**. ¹H NMR (CDCl₃, 360.15 MHz, TMS) δ 1.43 (br s, 6H, NH), 1.70-1.78 (m, CH₂CH₂CH₂NH₂ of **24** (2H) and CH₂CH₂CH₂ of **25** (4H)), 1.87 (p, 2H, J = 6.7 Hz, NCH₂CH₂CH₂N=C of **24**), 2.71 (t, 2H, J = 6.7 Hz, CH₂CH₂CH₂NH₂ of **24**), 2.72 (t, 4H, J = 6.7 Hz, CH₂CH₂CH₂NH₂ of **25**) 3.22-3.28 (m, 4H for **24**), 3.47-3.50 (m, 2H for **24**), 3.51-3.60 (m, 4H for **24**), 3.54 (s, 4H, NCH₂CH₂N of **25**), 3.58 (t, 4H, J = 6.7 Hz, NCH₂CH₂CH₂NH₂ for **25**); ¹³C NMR (CDCl₃, 90.56 MHz, ref central line of CDCl₃ set at 77.23) δ for **24**: 21.21 (CH₂CH₂CH₂N=), 30.73, 38.93, 45.02, 45.08, 45.14, 46.91, 47.43 (the amide and amidine resonances were not observed due to low signal to noise); for **25**: 30.73, 38.99, 44.67, 45.02, 157.69.

DIBALH Reduction of 2,3,4,6,7,9,10,11-Octahydropyrazino

[1,2-a:4,3-a']dipyrimidine (23). A 100 mL three-necked round bottomed-flask equipped with a reflux condenser and a N₂ inlet tube was charged with 2,3,4,6,7,9,10,11-octahydropyrazino[1,2-a:4,3-a']dipyrimidine (**23**) (0.152 g, 0.791 mmol). The reaction flask was cooled in an ice/H₂O bath prior to the introduction of DIBALH (1.5 M in tol, 5.0 mL, 7.5 mmol) by syringe. This mixture was heated at reflux for 4 d. An aliquot (~1 mL) was removed. NaF (0.26 g, 6.9 mmol) and H₂O (0.2 mL, 11.1 mmol) were added to this aliquot in small portions to quench the reaction. This mixture was concentrated by rotary evaporation, suspended in H₂O (8 mL), adjusted to pH

14 by the addition of KOH (pellets) and extracted with CHCl_3 (5×20 mL). The extracts were dried over Na_2SO_4 and concentrated to afford 46.6 mg of a crystalline product. NMR analysis of this material was consistent with *trans*-4a,4b-perhydro-4,5,8a,10a-tetraazaphenanthrene (*trans*-21) (see previous characterization).

Reduction of 2,3,4,6,7,9,10,11-Octahydropyrazino[1,2-a:4,3-a']dipyrimidine (23) with Lithium Aluminum Hydride (LiAlH_4). Dry THF (10 mL) was placed in a dried three-necked round-bottomed flask equipped with a reflux condenser with a N_2 inlet tube and an addition funnel. The flask was cooled in an ice/ H_2O bath. LiAlH_4 (0.26 g, 6.85 mmol) was added under N_2 to the THF. A solution of 2,3,4,6,7,9,10,11-octahydropyrazino[1,2-a:4,3-a']dipyrimidine (23) (0.131 g, 0.680 mmol) in THF (10 mL) was added via the addition funnel. The addition funnel was rinsed with additional THF (5 mL). The reaction mixture was heated at reflux under N_2 . After 5 hours, an aliquot (2.5 mL) was removed. H_2O (0.025 mL), 15% aq. KOH (0.025 mL) and H_2O (0.075 mL) were added successively while cooling the aliquot in an ice/ H_2O bath. The mixture was then filtered and the solids were washed with THF (5 mL). The filtrate was dried over Na_2SO_4 and concentrated by rotary evaporation. ^1H NMR analysis of the residue was consistent with *trans*-4a,4b-perhydro-4,5,8a,10a-tetraazaphenanthrene. The remainder of the reaction mixture was worked up in the same manner after 5 d at reflux. NMR analysis was again consistent with *trans*-4a,4b-perhydro-4,5,8a,10a-tetraazaphenanthrene (*trans*-21) as the only product of the reaction.

N,N'-Bis-(2-cyanoethyl)-1,2-phenylenediamine (32). The preparation of this compound was modeled on the procedure for the reaction of aryl amines and acrylonitrile reported by Heininger.⁷³ A 2-L three-necked round-bottomed flask equipped with a reflux condenser and a thermometer was charged with 1,2-phenylenediamine (100.00 g, 0.924 mol) and acrylonitrile (122 mL, 1.85 mol) suspended in CH₃CN (700 mL). Cupric acetate hexahydrate (4.87 g, 4.87 wt % based on the diamine) was added as a catalyst, and the resulting mixture was heated at reflux for 2 d. The reaction mixture was then concentrated by rotary evaporation affording a black sludge. 95% EtOH (250 mL) was added and the suspension was warmed until dissolution was complete. Water (250 mL) was then added and the mixture was again warmed until dissolution was complete. Slow cooling of this solution afforded 63.1 g of a black solid. Recrystallization of this material from 50% (v:v) aqueous EtOH afforded 44.1 g (22%) of purified product: mp: 113-114.5 °C (lit. 115-118 °C⁷³, 118.5-119 °C¹⁴⁹); ¹H NMR (CDCl₃, 360.15 MHz, TMS) δ 2.66 (t, 4H, NHCH₂CH₂CN, *J* = 6.5 Hz), 3.47 (app q, 4H, NHCH₂CH₂CN, *J*_{app} = 6.5 Hz), 3.72 (br t, 2H, NH), 6.70-6.74 (m, 2H, BB' of AA'BB'), 6.85-6.89 (m, 2H, AA' of AA'BB'); ¹³C NMR (CDCl₃, 90.56 MHz, ref. central line of CDCl₃ set at 77.23) δ 18.60, 40.66, 114.15, 118.62, 121.15, 136.40; IR (KBr) 3355 (NH), 2252 (CN) cm⁻¹; MS (EI) *m/z* 214.1 M⁺.

N,N'-Bis-(3-aminopropyl)-1,2-phenylenediamine (31). N,N'-Bis-

(2-cyanoethyl)-1,2-phenylenediamine (**32**) (5.00 g, 23 mmol) was dissolved in THF (130 mL) in a dry 500 mL three-necked round-bottomed flask equipped with a reflux condenser with a N₂ inlet tube and a pressure equalized addition funnel. NaBH₄ (5.53 g, 146 mmol) was added and the mixture was cooled in an ice/H₂O bath. A solution of AlCl₃ (4.8 g, 36.0 mmol) in THF (30 mL) was delivered to the addition funnel and added dropwise into the reaction flask. The resulting mixture was heated at reflux under N₂ for 20 h. The reaction mixture was again cooled in an ice/H₂O bath and aq. HCl (12 M, 75 mL) was added dropwise with vigorous stirring. The reaction mixture was then concentrated by rotary evaporation and dissolved in H₂O (200 mL). This solution was adjusted to pH 14 with KOH (pellets) and continuously extracted for 36 h under N₂ with toluene. The toluene extracts were dried over Na₂SO₄ and concentrated to afford 3.36 g of a brown oil. Kugelrohr distillation (0.02 Torr/ 150 °C) of this oil afforded 3.10 g (61%) of a yellow oil which solidified in the receiver. ¹H NMR (CDCl₃, 360.15 MHz, TMS) δ 1.49 (br s, 6H, NH's), 1.76 (p, 4H, CH₂CH₂CH₂, *J* = 6.7 Hz), 2.82 (t, 4H, CH₂NH₂, *J* = 6.7 Hz), 3.12 (t, 4H, NHCH₂, *J* = 6.7 Hz), 6.58-6.62 (m, 2H, BB' of AA'BB'), 6.69-6.73 (m, 2H, AA' of AA'BB'); ¹³C NMR (CDCl₃, 90.56 MHz, ref. central line of CDCl₃ set at 77.23) δ 33.24, 40.80, 42.81, 111.45, 119.15, 137.59. IR (neat) 3357, 3037, 2936, 2869, 1663, 1598 cm⁻¹; MS (EI) *m/z* 222.2 M⁺. (Elemental analysis verified that there was a trace amount of water in the product). **31** is labile towards oxidation and should either be used immediately or stored as a hydrochloride salt.

***Cis/trans*-1,2,3,4,9,10,11,12,12a,12b-decahydropyrazino[1,2-
a:4,3-a']-6,7-benzodiprimidine (33).** *N,N'*-Bis-(3-aminopropyl)-
1,2-phenylenediamine (**31**) (3.03 g, 13.6 mmol) was dissolved in absolute EtOH (40 mL).
Aqueous glyoxal (40 wt % aq. solution, 2.0 mL, 16.5 mmol) was taken up in CH₃CN (40
mL) and added in one portion to the amine solution. The resulting solution was heated at
reflux for 3 h under N₂. The reaction mixture was then concentrated and the residue was
taken up in CHCl₃ (100 mL), dried over Na₂SO₄ and concentrated to afford a foam. This
foam was taken up in CHCl₃ (15 mL) and diluted with Et₂O (100 mL). A precipitate
formed which was removed by vacuum filtration. The filtrate was concentrated to afford
2.97 g (89%) of an oil which solidified. The ratio of the two isomers was 71:21 by ¹H
NMR integration. ¹H NMR (CDCl₃, 360.15 MHz, TMS) δ 1.40 (dm, CH₂CHHeqCH₂, *J*
= 12.8 Hz), 1.52 (dm, CH₂CHHeqCH₂, *J* = 13.1 Hz), 1.66-1.89 (m, CH₂CHHaxCH₂
and NH of both isomers), 2.83-3.21 (m), 3.90 (s, NCHN), 3.95-4.03 (m), 4.03 (s,
NCHN), 6.67-6.91 (m, aromatics); ¹³C NMR (CDCl₃, 90.56 MHz, ref central line of
CDCl₃ set at 77.23) δ major: 25.64, 44.34, 47.55, 70.19, 113.16, 119.62, 135.28; δ
minor: 23.93, 45.34, 47.55, 74.09, 113.75, 119.80, 134.72; MS (EI) *m/z* 244.2 M⁺.
This mixture was refluxed with *p*-toluenesulfonic acid (1eq) in EtOH for 3 d. This solution
was then concentrated, taken up in water and adjusted to pH 14 with solid KOH (pellets).
Extraction with CHCl₃ afforded a crude oil after drying and concentration of the extracts.
¹H NMR spectra of the oil showed that the minor isomer had become the major isomer. It
is not known if this is an equilibrium mixture of the isomers.

5,6,7,8,9,10,11,12,13,14,15,16-Dodecahydro-5,9,12,16-tetraaza-benzocyclotetradecane, "Benzocyclam" (34). A 250 mL three-necked round-bottomed flask equipped with a reflux condenser with a N₂ inlet tube and a pressure equalizing addition funnel was charged with *Cis/trans*-1,2,3,4,9,10,11,12,12a,12b-decahydropyrazino [1,2-a:4,3-a']-6,7-benzo-dipyrimidine (33) (2.97 g, 12.0 mmol). The reaction flask was cooled in an ice/H₂O bath prior to the dropwise addition of DIBALH (1.5 M solution in toluene, 64 mL, 96 mmol) via the addition funnel. This mixture was heated at reflux for 4 days. The reaction mixture was then cooled in an ice/H₂O bath and toluene (65 mL) was added. The reaction was quenched by the cautious dropwise addition of 3 M KOH (65 mL). The mixture was concentrated by rotary evaporation, the residue was dissolved in H₂O (50 mL), adjusted to pH 14 with KOH (pellets), and then extracted with CHCl₃ (5×50 mL) while N₂ was bubbled through the solution to minimize oxidation of the product. The CHCl₃ extracts were dried over Na₂SO₄ and concentrated. The residue was immediately dissolved in 95% EtOH (100 mL) and HCl (12 M, 50 mL) was added dropwise. The solution was removed by rotary evaporation. Trituration of the resulting solid with absolute EtOH (100 mL) followed by vacuum filtration afforded a brown solid. ¹H NMR (D₂O, 360.15 MHz, secondary ref. CH₃CN set at 2.05) δ 2.12 (p, 4H, *J* = 6.4 Hz, CH₂CH₂CH₂), 3.34 (t, 4H, *J* = 6.7 Hz), 3.49 (s, 4H, CH₂CH₂), 3.55 (t, 4H, *J* = 6.4 Hz), 7.23 (s, 4H, ArH); ¹³C NMR (D₂O, 90.56 MHz, 2° ref CH₃CN set at 1.70) δ 22.83, 42.22, 44.28, 46.01, 119.9, 126.0,

133.4. This brown solid was dissolved in water (25 mL) and the solution was adjusted to pH 14 by the addition of KOH (pellets). N₂ was bubbled through the solution to minimize oxidation of the product. This solution was then extracted with toluene (5×50 mL) and the toluene extracts were dried over Na₂SO₄ and concentrated by rotary evaporation to afford 1.70 g (57%) of a gray solid: mp: 129-130 °C; ¹H NMR (CDCl₃, 360.15 MHz, TMS) δ 1.82-1.88 (m, 4H, CH₂CH₂CH₂), 1.68 (br s, NH), 2.72 (s, 4H), 2.88-2.91 (m, 4H), 3.26-3.29 (m, 4H), 5.59 (br s, 2H, ArNH), 6.54-6.58 (m, 2H, BB' of AA'BB'), 6.70-6.75 (m, 2H, AA' of AA'BB'); ¹³C NMR (CDCl₃, 90.56 MHz, ref central line of CDCl₃ set at 77.23) δ 27.35, 46.04, 49.79, 51.02, 109.74, 118.18, 137.80; IR (neat) 3325, 3289, 3248, 2931, 2875, 2832, 1657, 1595, 1546, 1454 cm⁻¹; MS (EI) *m/z* 248.3 (M⁺); Anal. Calcd for C₁₄H₂₄N₄: C, 67.70, H, 9.74, N, 22.56; Found: C, 67.65, H, 9.81, N, 22.51.

Tetrakis-(dimethylamino)-ethylene dibromide (44). This compound was prepared by the method of Bock et al.⁸¹ A three necked flask equipped with an addition funnel and reflux condenser was charged with Et₂O (100 mL) which was degassed by bubbling N₂ into the liquid through a glass frit. Tetrakis-(dimethylamino)-ethylene (43) (3.62 g, 18.1 mmol) was added and no luminescence was observed. The reaction flask was cooled in an ice/H₂O bath and a solution of Br₂ (3.02 g, 19.0 mmol) in degassed Et₂O (100 mL) was introduced dropwise via the addition funnel producing an immediate reaction. The addition of the bromine solution continued over one hour. The reaction

mixture was slowly warmed to room temperature and left stirring under N₂ for 12 hours. The reaction mixture was concentrated by rotary evaporation and residual solvent was removed under vacuum. 6.08 g (93%) of a white-yellow solid was obtained: ¹H NMR (D₂O, 360.15 MHz, 2° ref CH₃CN set at 2.05) δ 3.30 (s, 12H), 3.58 (s, 12H); ¹³C NMR (D₂O, 90.56 MHz, 2° ref CH₃CN set at 1.7) δ 43.15, 44.08, 156.68. Spectra were consistent with reported results.⁸¹

Attempts to Prepare 2,3,5,6,8,9-Hexahydrodiimidazo[1,2-a:2',1'-c]pyrazine (16) Using Other Reagents.

From Tetrakis-(dimethylamino)-ethylene dibromide (44). Triethylenetetraamine (0.186 g, 1.27 mmol) was placed in a 5 mL round-bottomed flask with tetrakis-(dimethylamino)-ethylene dibromide (44) (0.46 g, 1.3 mmol). This mixture was heated to 150°C under N₂ and a small strip of wet litmus paper, which had been placed inside the N₂ exit manifold, indicated that a basic gaseous species was being evolved. The heat was continued for one hour. Toluene (5 mL) was added and heated to reflux. The heat was removed and the toluene was removed while still warm by pipette. Concentration of these toluene extracts by rotary evaporation afforded an oil. ¹H NMR analysis of this oil confirmed the formation of 2,3,5,6,8,9-hexahydrodiimidazo[1,2-a:2',1'-c]pyrazine (16). While not pure, the bisamidine was the major component in this NMR sample. However, there was a substantial amount of solid left in the reaction flask which was not soluble in toluene. Other solvents were investigated (ethanol, isopropanol, *n*-butanol) in addition to

adding the corresponding sodium salt of the alcohol solvent to consume the HBr generated.

Unfortunately, the experimental details given above were the most successful conditions found.

From Oxalic Acid. Triethylenetetraamine (crude, 6.06 g, ~29 mmol) was dissolved in ethyleneglycol (7 mL). Oxalic acid (2.66 g, 29 mmol) was added and the mixture was heated to reflux under N₂ for 7 hours. The ethylene glycol mixture was extracted with CHCl₃ (3 x 10 mL). The CHCl₃ extracts were dried over Na₂SO₄ and concentrated by rotary evaporation. ¹H NMR analysis provided no evidence for the formation of 2,3,5,6,8,9-hexahydrodiimidazo[1,2-a:2',1'-c]pyrazine (**16**). Another attempt was performed as a neat reaction. No evidence for the formation of (**16**) was observed.

From Diethyloxalate. Triethylenetetraamine (crude, 3.95 g, ~18 mmol) was placed in a 50 mL round-bottomed flask equipped with a short path distillation head. Upon the addition of diethyloxalate (2.71 g, 19 mmol) the flask became very hot and a precipitate formed. The mixture was heated until a distillate was collected (74°C). The distillate was determined to be EtOH by ¹H NMR. NMR of the reaction mixture in CDCl₃ showed many new peaks in the 3.0-3.6 region of the ¹H NMR spectrum. Evidence for the formation of (**16**) (¹H NMR: δ 3.85 (t), ¹³C NMR δ 155.7 (N-C=N) was observed but this product was clearly a complicated mixture.

2,2'-Bibenzimidazole (45). This compound was prepared by the method of Fieselmann.⁸⁵ A three-necked 250 mL round-bottomed flask equipped with a reflux

condenser and a N₂ inlet tube was charged with 1,2-phenylenediamine (45.0 g, 0.40 mmol), oxamide (17.6 g, 0.02 mmol) and ethylene glycol (40 mL). This mixture was heated to reflux under N₂ for 2 d. The reaction mixture was poured into boiling water (800 mL) which induced precipitation of a solid. The solid was isolated by gravity filtration of the mixture while hot and then vacuum filtration removed residual solvent. 31.58 (68%) of solid was isolated. The product was insoluble in most NMR solvents (C₆D₆, CD₃CN, D₂O, Acetone-*d*₆): decomposition point: 392-394 °C (lit⁸⁵: 395-400 °C).

6,7-Dihydropyrazino[1,2-a:4,3-a']bisbenzimidazole (46). This procedure is similar to that reported by Roechling et al.⁸³ A mineral oil dispersion of NaH (0.75 g, 60 wt %, 18 mmol) was washed with Et₂O (3×10 mL) and the residual solvent was removed with a stream of N₂ under mild heating. The NaH was suspended in dry DMF (5 mL) prior to the addition of 2, 2'-bibenzimidazole (45) (1.89 g, 8.07 mmol) under N₂. The mixture immediately turned green. 1,2-Bis[(*p*-tolylsulfonyl)oxy]ethane (2.97 g, 8.01 mmol) was added 0.5 h later and the reaction mixture was heated to reflux. After 4 days the heat was evaporated and the solvent was removed making sure that all residual DMF was removed. The solids were taken up in boiling EtOH (100 mL) and a hot filtration was performed. The filtrate was concentrated and the residue was taken up in CHCl₃ and dried over Na₂SO₄. The solvent was then evaporated and the residue was recrystallized from EtOH to afford 181.1 mg (8.3%) of fine crystals. The crystals were ground up and heated for 3 days under vacuum at 100°C. Even under these conditions, ¹H NMR showed there was still H₂O

present in the sample. The solid was found to have poor solubility in common organic solvents at room temperature: dec. point: 392-397 °C (lit⁸³ > 360 °C); ¹H NMR (CDCl₃, 360.15 MHz, TMS) δ 4.67 (s, 4H), 7.44-7.26 (m, 6H), 7.93-7.91 (d, 2H, *J* = 7.2 Hz); ¹³C NMR (CDCl₃, 90.56 MHz, ref central line of CDCl₃ set at 77.23) δ 40.84, 109.44, 121.66, 123.70, 124.56, 134.29, 141.73, 144.39; IR (KBr) 3051, 2973, 2931, 1616, 1468, 1448, 1413, 1377, 1342 cm⁻¹.

Attempted Reduction of 6,7-dihydropyrazino[1,2-a:4,3-a']bisbenzimidazole (46) with DIBALH. DIBALH (1.5 M in Toluene., 2.0 mL, 3.0 mmol) was introduced dropwise via syringe under N₂ to an ice/H₂O cooled three necked flask equipped with a reflux condenser with a N₂ inlet tube containing 6,7-dihydropyrazino[1,2-a:4,3-a'] bisbenzimidazole (46) (0.025 g, 0.096 mmol). The solution immediately turned red/brown. Toluene (2 mL) was added and the resulting mixture was heated at 100 °C for 20 h. The heat was then removed and the reaction was quenched by the alternate addition of NaF (0.30 g, 7.0 mmol) and H₂O (0.2 mL, 11 mmol) in small portions. Toluene (20 mL) was added and the mixture was filtered. The solids were washed with CHCl₃ (2×10 mL) and the combined filtrates were dried over Na₂SO₄. The filtrates were then concentrated to afford 32.6 mg of crude product (over 100% of theoretical). ¹H NMR showed that reduction was not clean but formation of the desired product could not be ruled out. MS (EI) analysis showed a molecular ion of *m/z* 266 which corresponds a molecular formula of C₁₆H₁₈N₄. The molecular ion for dibenzocyclen (C₁₆H₂₀N₄) was not observed. This

reaction was repeated and the reaction time was increased to 4 days. There was no apparent change in the products of the reaction as evaluated by ^1H NMR.

7,8-Dihydro-6-H-bisbenzimidazo[1,2-a:2',1'-c][1,4]diazepine (47).

2,2'-Bibenzimidazole (45) (1.00 g, 4.30 mmol) was suspended in CH_3CN (30 mL) in a 100 mL round-bottomed flask. 1,3-Bis[(p-tolylsulfonyl)oxy]propane (1.65 g, 4.29 mmol) was added and the mixture was stirred vigorously while a 20% solution of KOH (5 mL) was added by pipette. This mixture was left stirring at room temperature for 24 hours. Precipitation of the product was induced by the addition of water (100 mL) to the reaction mixture. The solids were isolated by vacuum filtration and washed with CHCl_3 (3 \times 20 mL). The CHCl_3 washings were dried over Na_2SO_4 and concentrated. The residue was washed with toluene (30 mL) which removed excess 1,3-bis[(p-tolylsulfonyl)oxy]propane. The remaining solid was recrystallized from CH_3CN to afford 0.110 g (9%) of tan needles: mp: 320-322 $^\circ\text{C}$; ^1H NMR (CDCl_3 , 360.15 MHz, TMS) δ 2.60-2.66 (m, 2H), 4.45-4.48 (m, 4H), 7.26-7.32 (m, 6H), 7.86-7.90 (m, 2H); ^{13}C NMR (90.56 MHz, CDCl_3 , ref central line of CDCl_3 set at 77.23) δ 26.83, 45.13, 109.62, 121.20, 123.41, 124.05, 135.95, 143.41, 143.60; IR (KBr) 1313, 1376, 2932, 3050 cm^{-1} . Elemental analysis showed that there was trace water (less than a hydrate) associated with 47.

Attempted DIBALH Reduction of 7,8-Dihydro-6-H-

bisbenzimidazo[1,2-a:2',1'-c][1,4]diazepine (47). A 10 mL two-necked round-

bottomed flask equipped with a reflux condenser and a N₂ inlet tube was charged with 7,8-dihydro-6-H-bisbenzimidazo[1,2-a:2',1'-c][1,4]diazepine (**47**) (12.1 mg, 0.044 mmol). The reaction flask was cooled in an ice/H₂O bath prior to the addition of DIBALH (1.5 M in toluene, 2 mL, 3 mmol) via syringe. The reaction was heated at reflux for 2 d. The reaction mixture was cooled in an ice/H₂O bath and toluene (5 mL) was added. The reaction was then quenched by the dropwise addition of 20% aq. KOH (2 mL). The mixture was transferred to a separatory funnel, the layers were separated, and the aqueous layer was extracted with CHCl₃ (4×20 mL). The combined organic extracts were dried over Na₂SO₄ and concentrated by rotary evaporation to afford a white residue. ¹H NMR analysis (CDCl₃) of this residue was carried out. The product was clearly a mixture but the ring expanded product was indicated: ¹H NMR (CDCl₃, 360.15 MHz, TMS) δ 1.13-1.30 (m, NCH₂CH₂CH₂N), 2.74 (s, NCH₂CH₂N), 4.20 (t, NCH₂CH₂CH₂N), 6.49-6.79 (m, ABCD for ArH). This hypothesis was not tested using other spectroscopic techniques. It is unknown if the reaction was incomplete or if the other observed resonances were a result of oxidation of the product.

2,2'-Biimidazoline (bis(Δ²-2-imidazoliny) (11**)).** **11** was prepared by a modification of the method of Forssell.⁵¹ A 100 mL three necked round-bottom flask equipped with a reflux condenser with a nitrogen inlet tube, pressure-equalized addition funnel, fritted gas dispersion tube (initially closed) and a magnetic stirrer was charged with dithiooxamide (2.60 g, 21.6 mmol) and absolute ethanol (10 mL). The nitrogen manifold

exit line was routed through two fritted gas washing bottles charged with 20% aqueous NaOH in order to trap H₂S evolved. A solution of ethylenediamine (2.60 g, 43.3 mmol) in absolute ethanol (10 mL) was introduced to the reaction flask in one portion via the addition funnel. The mixture was then heated for 6 hours at reflux under nitrogen with the evolution of H₂S and NH₃. The reaction mixture was then cooled to room temperature and residual H₂S and NH₃ were purged from the solution by entrainment with nitrogen, which was bubbled through the mixture from the fritted gas dispersion tube for 18 hours. The reaction mixture was filtered isolating 1.68 g (56%) of a tan solid. The product can be further purified by recrystallization from CH₃CN: decomposition point: 259°C (lit¹⁴⁸); ¹³C NMR (DMSO-*d*₆, 90.56 MHz, ref central line of DMSO-*d*₆ set at 39.5) δ 40.20, 146.36; IR (KBr) 1615 cm⁻¹; MS (EI) *m/z* 138.1 M⁺; Anal. Calcd for C₆H₁₀N₄: C, 52.16; H, 7.29; N, 40.55; Found: C, 51.89; H, 7.38; N, 40.35.

**Attempted Synthesis of 2,3,5,6,8,9-Hexahydrodiimidazo[1,2-
a:2',1'-c]pyrazine (16) From 2,2'-Biimidazoline (11) and 1,2-**

Dibromoethane. A 10 mL round bottomed flask was charged with 2,2'-biimidazoline (40.9 mg, 0.296 mmol), potassium iodide (6.1 mg, 0.037 mmol) and potassium carbonate (400 mg, 2.90 mmol) and CH₃CN (2 mL). A solution of 1,2-dibromoethane (0.0601 g, 0.319 mmol) in CH₃CN (2 mL) was added in one portion and the resulting suspension was heated at reflux for 20 h. The mixture was diluted with CH₃CN (5 mL), filtered through a glass wool plug and the filtrate was concentrated. NMR analysis was consistent

with NMR data for the starting materials and no evidence for the formation of **16** was found.

1,1'-Bis-(trimethylsilyl)-2,2'-bimidazoline (49). **49** was prepared by the literature method.⁸⁵ 2,2'-Biimidazoline (**11**) (1.00 g, 7.24 mmol) was placed in a 100 mL three-necked round-bottomed flask equipped with a reflux condenser with N₂ inlet tube. The apparatus was flushed with N₂ prior to the delivery of hexamethyldisilazane (**48**) (HMDS, 6.1 mL, 29 mmol) via syringe. H₂SO₄ (conc, 10 μL) was added and the resulting mixture was heated at reflux for 19 hours. A short path distillation head was exchanged for the condenser and the excess HMDS was removed by vacuum distillation (0.5 Torr). The residue was further pumped down under vacuum for 3 days to remove volatile byproducts. The mass of crude product was over 100% of theoretical but NMR analysis supported product formation. ¹H NMR (CDCl₃, 360.15 MHz, TMS) δ 0.22 (s), 3.43 (t, XX' of AA'XX'), 3.76 (t, AA' of AA'XX'); ¹³C NMR (CDCl₃, 90.56 MHz, ref central line of CDCl₃ set at 77.23) δ 0.152, 48.02, 55.04, 159.60.

Attempted Synthesis of 36 from 1,1'-Bis-(trimethylsilyl)-2,2'-bimidazoline (49) and 1,3-Bis[(p-tolylsulfonyl)oxy]propane. A 50 mL three-necked round-bottomed flask equipped with a reflux condenser, a N₂ inlet tube and a pressure-equalized addition funnel was charged with 1,3-bis[(p-tolylsulfonyl)oxy]propane (0.26 g, 0.67

mmol). A solution of 1,1'-bis-(trimethylsilyl)-2,2'-bimidazoline (**49**) (0.19 g, 0.67 mmol) in CH₃CN (15 mL) was added via the addition funnel and the resulting reaction mixture was heated for 4 d at reflux under N₂. The reaction mixture was then concentrated by rotary evaporation. The residue was suspended in CDCl₃ but most of the material did not dissolve. ¹H NMR analysis of the material which was soluble in CDCl₃ was not consistent with the formation of **36**. The major component of this solution was identified as 1,3-bis[(*p*-tolylsulfonyl)oxy]propane. It is likely that the reaction was not facile and the insoluble material was 2,2'-biimidazoline (**11**) which is insoluble in CDCl₃. 2,2'-Biimidazoline was generated by the hydrolysis of 1,1'-bis-(trimethylsilyl)-2,2'-bimidazoline.

1,4-Bis-(2-aminoethyl)-2,3-piperazinedione (50). 2,3,5,6,8,9-hexahydrodiimidazo[1,2-*a*:2',1'-*c*]pyrazine (**16**) was dissolved in H₂O and left for 14 h. The solution was concentrated by rotary evaporation and the residue was taken up in CHCl₃ and dried over Na₂SO₄. Concentration of the filtrate after the removal of the drying agent afforded a white waxy solid: mp: 111-112 °C; ¹H NMR (CDCl₃, 360.15 MHz, TMS) δ 1.27 (br s, 4H, NH₂), 2.95 (t, 4H, *J* = 6.3 Hz, CH₂CH₂NH₂), 3.54 (t, 4H, *J* = 6.3 Hz, CH₂CH₂NH₂), 3.64 (s, 4H, NCH₂CH₂N); ¹³C NMR (CDCl₃, 90.56 MHz, ref central line of CDCl₃ set at 77.23) δ 39.92, 45.60, 50.76, 158.02; IR (KBr) 3387.7 (NH asym.), 3317 (NH sym.), 1667 cm⁻¹; MS (CI, isobutane) *m/z* 183.2 (M-18+1).

1-Aminoethyl-4-aminopropyl-2,3-piperazinedione (53). In an NMR experiment, 2,3,4,5,5a,6,7,8-octahydro-1,3a,5,9-tetraazabenzindene (**18**) was taken up in D₂O. After 24 h, NMR spectra were acquired: ¹H NMR (D₂O, 360.15 MHz, secondary ref CH₃CN set at 2.05) δ 1.73 (p, 2H, *J* = 7.1 Hz, CH₂CH₂CH₂), 2.61 (t, 2H, *J* = 7.0 Hz, CH₂CH₂CH₂NH₂), 2.83 (t, 2H, *J* = 6.4 Hz, CH₂CH₂NH₂), 3.49 (t, 2H, *J* = 6.4 Hz, CH₂CH₂CH₂NH₂ or CH₂CH₂NH₂), 3.50 (t, 2H, *J* = 6.4 Hz, CH₂CH₂CH₂NH₂ or CH₂CH₂NH₂), 3.62-3.73 (m, AA'XX', 4H, NCH₂CH₂N); ¹³C NMR (90.56 MHz, D₂O, secondary ref CH₃CN set at 1.7) δ 29.83, 38.64, 44.80, 45.28, 46.02, 50.67, 159.17, 159.61. Attempts to isolate and fully characterize this compound were carried out.

2,3,4,5,5a,6,7,8-Octahydro-1,3a,5,9-tetraazabenzindene (**18**) was taken up in H₂O. After 24 h the water was removed by a stream of N₂ which was blown over the solution. The residue was taken up in CHCl₃ and dried over Na₂SO₄. Concentration of this solution by rotary evaporation afforded an oil. NMR analysis supports a mixture of two compounds which were not separated. One of the species was 1-aminoethyl-4-aminopropyl-2,3-piperazinedione (**53**). The other, **54**, must arise from dehydration of **53** which occurred in the rotary evaporation process. The aminopropyl chain condensed with the tertiary amide and formed a six-membered ring to give a species having one amidine and one amide moiety. ¹H NMR showed that the ratio of **53**:**54** was 68:32: ¹H NMR (CDCl₃, 360.15 MHz, TMS) δ 1.53 (br s, NH) 1.73 (p, 2H, *J* = 6.7 Hz, NCH₂CH₂CH₂NH₂, **53**) 1.87 (p, 2H, *J* = 5.9 Hz, NCH₂CH₂CH₂N, **54**) 2.73 (t, 2H, *J* = 6.7 Hz, NCH₂CH₂CH₂NH₂) 2.91 (t, 2H, *J* = 6.7 Hz, NCH₂CH₂NH₂, **54**) 2.96 (t, 2H, *J* = 6.7

Hz, $\text{NCH}_2\text{CH}_2\text{NH}_2$, **53**) 3.23-3.31 (m, 4H, $\text{NCH}_2\text{CH}_2\text{CH}_2\text{N=}$ and $\text{O=CNCH}_2\text{CH}_2\text{CNC=N}$, **54**) 3.52-3.66 (m, 8H **53** and 6H **54**); ^{13}C NMR (CDCl_3 , 90.56 MHz, ref central line CDCl_3 set at 77.23) δ 20.93, 30.49, 38.82, 39.71 (2 C's), 44.45, 44.73, 44.86, 45.34, 45.79, 46.67, 47.16, 50.53, 50.99, 147.6, 157.6, 157.8, 159.0.

Protonation of 2,3,5,6,8,9-Hexahydrodiimidazo[1,2-a:2',1'-c]pyrazine (16) with Trifluoroacetic Acid (TFA) in CD_3CN .

2,3,5,6,8,9-Hexahydrodiimidazo[1,2-a:2',1'-c]pyrazine (**16**) (0.0269 g, 0.164 mmol) was taken up in CD_3CN and NMR spectra were acquired: ^1H NMR (CD_3CN , 360.15 MHz, ref central line of CD_2HCN set at 1.94) δ 3.20 (s, 4H), 3.28 (t, 4H), 3.70 (t, 4H); ^{13}C NMR (CD_3CN , 90.56 MHz, ref central line of CD_3CN set at 1.39) δ 46.29, 52.74, 54.63, 156.48. TFA (6.3 μL , 0.08 mmol, 0.5 eq) was added via syringe and spectra were acquired: ^1H NMR (CD_3CN , 360.15 MHz, ref central line of CD_2HCN set at 1.94) δ 3.33 (s, 4H), 3.48 (t, 4H), 3.82 (t, 4H), 8.13 (br s, H); ^{13}C NMR (CD_3CN , 90.56 MHz, ref central line of CD_3CN set at 1.39) δ 45.32, 52.30, 52.76, 155.08. TFA (6.3 μL , 0.08 mmol, 1.0 eq total) was added via syringe and spectra were acquired: ^1H NMR (CD_3CN , 360.15 MHz, ref central line of CD_2HCN set at 1.94) δ 3.45 (s, 4H), 3.65 (t, 4H), 3.92 (t, 4H), 8.93 (br s, 1H); ^{13}C NMR (CD_3CN , 90.56 MHz, ref central line of CD_3CN set at 1.39) δ 44.58, 50.98, 51.95, 153.62. TFA (12.6 μL , 0.16 mmol, 2.0 eq total) was added via syringe and spectra were acquired: ^1H NMR (CD_3CN , 360.15 MHz, ref central line of

CD_2HCN set at 1.94) δ 3.41 (s), 3.59 (t), 3.88 (t), 9.02 (br s). Significant hydrolysis of the substrate had taken place making integration of this spectrum difficult.

2-Benzyl-2,3,5,6,8,9-hexahydrodiimidazo[1,2-a:2',1'-c]pyrazinium

bromide (60). 2,3,5,6,8,9-Hexahydrodiimidazo[1,2-a:2',1'-c]pyrazine (16) (1.00 g, 6.09 mmol) was suspended in toluene (20 mL). CH_3CN was then added dropwise to this suspension with stirring until dissolution was complete. Benzyl bromide (0.75 mL, 6.3 mmol) was then added in one portion and the resulting mixture was stirred in the dark at room temperature under N_2 . After 3 days the reaction mixture was filtered to afford a yellow crystalline solid. This solid was washed (3 \times 10 mL) with toluene which removed some of the yellow color. Removal of residual solvent under vacuum afforded 1.97 g (96%) of product: mp: 205°C with decomposition; ^1H NMR (CDCl_3 , 360.15 MHz, TMS) δ 3.47 (t, 2H, $J = 10.1$ Hz), 3.58 (t, 2H, $J = 6.0$ Hz), 3.93-4.13 (m, 4H), 4.38 (t, 2H, $J = 12.5$ Hz), 5.41 (s, 2H, NCH_2Ph), 7.31-7.45 (m, 5H, Ar-H); ^{13}C NMR (CDCl_3 , 90.56 MHz, ref. central line of CDCl_3 set at 77.23) δ 43.75, 44.91, 49.16, 49.63, 50.97, 52.47, 55.39, 128.87, 129.04, 129.37, 133.44, 151.25, 151.35; IR (KBr) 2971, 2855, 1655, 1621, 1573, 1305 cm^{-1} ; MS (EI) m/z 255.3 M^+ .

Reduction of 2-Benzyl-2,3,5,6,8,9-hexahydrodiimidazo[1,2-a:2',1'-c]pyrazinium bromide (60). A 50 mL three necked round bottomed flask equipped with a reflux condenser with a N₂ inlet tube was charged with 2-benzyl-2,3,5,6,8,9-hexahydrodiimidazo[1,2-a:2',1'-c]pyrazinium bromide (60) (0.15 g, 0.45 mmol). DIBALH (1.5 M in toluene, 3.0 mL, 4.5 mmol) was added via syringe and this mixture was heated to reflux. After 3 d the reaction mixture was cooled in an ice/H₂O bath and toluene (10 mL) was added. The reaction was quenched by the dropwise addition of 3M KOH (10 mL). The mixture was transferred to a separatory funnel, the layers were separated and the aqueous layer was extracted with CHCl₃ (6×20 mL). The combined extracts were dried over Na₂SO₄ and concentrated by rotary evaporation to afford 0.119 g of an oil. ¹³C NMR analysis was consistent with a mixture of three species in the sample which were not separated. The major component is consistent with 1-benzyl-1,4,7,10-tetraazabicyclo[7.3.0]dodecane (62): ¹³C NMR (CDCl₃, 90.56 MHz, ref central line of CDCl₃ set at 77.23) δ (aliphatic carbons only) 43.6, 45.7, 48.7, 52.0, 52.5, 54.0, 55.4, 57.4, 75.8. The other two components (isomers 63 and 64) could be formed from further reduction by DIBALH of 1-benzyl-1,4,7,10-tetraazabicyclo[7.3.0]dodecane (62). These compounds result from the cleavage of different C-N bonds of the amination moiety of 62. Isomer 63 was in greater abundance over isomer 64 which allowed for the assignment of the aliphatic chemical shifts: isomer 63 (1-

(aminoethyl-N-benzyl)-1,4,7-triazacyclononane) ^{13}C NMR (CDCl_3 , 90.56 MHz, ref central line of CDCl_3 set at 77.23) δ 44.9, 46.2, 47.0, 51.1, 53.1, 59.1; isomer **64** (1-benzyl-1,4,7,10-tetraazacyclododecane): ^{13}C NMR (CDCl_3 , 90.56 MHz, ref central line of CDCl_3 set at 77.23) δ 46.5, 46.7, 47.6, 52.0, 57.2. The aromatic chemical shifts for **62**, **63** and **64** could not be assigned: 125.23, 126.62, 126.84, 126.99, 128.03, 128.12, 128.29, 128.31(d), 137.72, 138.82, 140.33.

This reaction was repeated under the same conditions for 12 d. The results were the same except that more of isomers **63** and **64** were formed with respect to **62**. The ratio of **63** to **64** was still the same (estimated by ^{13}C line height) whereby more of **63** was formed over **64**.

Hydrolysis of 2-Benzyl-2,3,5,6,8,9-hexahydrodiimidazo[1,2-a:2',1'-c]pyrazinium bromide (60). 2-Benzyl-2,3,5,6,8,9-

hexahydrodiimidazo[1,2-a:2',1'-c]pyrazinium bromide (**60**) was taken up in D_2O and NMR spectra were acquired to determine the regioselectivity of hydrolysis. The resultant NMR spectra were consistent with a mixture of two isomers which result from the loss of regiochemical control of the hydrolysis of the amidinium moiety of (**60**), affording a mixture of **65** and **66**. The ratio of **65**:**66** was approximately 50:50. The initial NMR experiment was carried out 14 h after the sample had been prepared: ^1H NMR (D_2O , 360.15 MHz, secondary ref CH_3CN set at 2.05) δ 2.88 (dt, 4H, $\text{NCH}_2\text{CH}_2\text{NH}_2$ both isomers, $J_{\text{obs}} = 6.4$ Hz), 2.97 (t, 2H, $J = 6.1$ Hz), 3.07 (t, 2H, $J = 6.7$ Hz), 3.17 (t, 2H, J

= 6.1 Hz), 3.58-3.74 (m, 12H), 3.91 (s, 2H, NCH₂Ph), 4.66 (s, 2H, NCH₂Ph), 7.35-7.45 (m, 10H, ArH); ¹³C NMR (D₂O, 90.56 MHz, secondary ref CH₃CN set at 1.7) δ 38.32, 39.38, 44.54, 45.06, 45.17(2C's), 45.26, 45.88, 46.29, 46.84, 47.09, 47.46, 51.57, 52.63, 128.80, 128.98, 129.71 (2C's), 129.84 (2C's), 136.04, 137.21, 159.31, 159.52, 159.73, 160.12. NMR spectra which were acquired 48 h after the sample had been prepared were identical.

Attempted Reaction of *p*-Toluenesulfonylchloride with

2,3,5,6,8,9-Hexahydrodiimidazo[1,2-*a*:2',1'-*c*]pyrazine (16).

2,3,5,6,8,9-Hexahydrodiimidazo[1,2-*a*:2',1'-*c*]pyrazine (**16**) (0.255 g, 1.56 mmol) was suspended in toluene (10 mL) in a 50 mL round-bottomed flask. CH₃CN was added dropwise until dissolution of the solid was complete. *p*-Toluenesulfonylchloride (0.29 g, 1.5 mmol) was then added and the reaction mixture was stirred for 6 d at room temperature under N₂. A precipitate had formed and was isolated by vacuum filtration. The solid was washed with toluene (25 mL) and was oily in appearance. Unfortunately, the only NMR solvent in which this solid was soluble was DMSO-*d*₆. The DMSO-*d*₆ was contaminated with water. NMR and MS analysis of this solid was consistent with two species present in the sample. The minor component was 2,3,5,6,8,9-hexahydrodiimidazo[1,2-*a*:2',1'-*c*]pyrazine (**16**) starting material. The major component (**73**) was derived from the hydrolysis of the desired tosylated product (**69**): ¹H NMR (DMSO-*d*₆, 360.15 MHz, TMS) δ 2.39 (s, 3H, CH₃), 2.95 (dt, 2H, *J* = 6.6, 5.8 Hz, CH₂CH₂NHTs), 3.4 (br s,

NH) 3.47-3.35 (m, 2H) 3.35 (s, NCNCH₂CH₂NCN of **16**), 3.59-3.75 (m, 2H and t, 2H, *J* = 9.5 Hz, NCH₂CH₂N=C of **16**), 3.90 (t, 2H, *J* = 9.8 Hz, NCH₂CH₂N=C of **16**), 3.97-4.06 (m, 2H), 7.41 (XX' of AA'XX', 2H), 7.69 (AA' of AA'XX', 2H), 7.91 (t, 1H, *J* = 6.2, NHTs); ¹³C NMR (DMSO-*d*₆, 90.56 MHz, ref central line of DMSO-*d*₆ set at 39.5) δ 20.97, 41.28, 43.06, 43.78, 45.24, 46.50, 49.14, 50.72, 50.87, 126.54, 129.69, 137.36, 142.81, 151.55, 152.00, 155.57; MS (EI) *m/z* 164 M⁺ (**16**), 336 M⁺ (**73**).

Reaction of 2,3,5,6,8,9-Hexahydrodiimidazo[1,2-a:2',1'-c]pyrazine (16**) with 1,2-Bis[*p*-tolylsulfonyl]oxy]ethane.**

2,3,5,6,8,9-Hexahydrodiimidazo[1,2-a:2',1'-c]pyrazine (0.10 g, 0.60 mmol) was dissolved in CH₃CN (10 mL) in a 50 mL round bottomed flask. 1,2-Bis[*p*-tolylsulfonyl]oxy]ethane (0.22 g, 0.60 mmol) was added in one portion and the mixture was heated at reflux under N₂ for 2 d. The reaction mixture was then concentrated by rotary evaporation to afford an oil. ¹H NMR analysis (CDCl₃) of this material showed the two starting materials, many resonances in the 3-4.4 ppm region and three broad singlets (4.2, 4.1, 3.9 ppm). Interpretation of these signals was difficult, therefore purification was attempted. A small sample of the oil was taken up in EtOH and added dropwise to a saturated solution of NaBPh₄ in EtOH. A precipitate formed which was isolated by vacuum filtration. NMR analysis (DMSO-*d*₆) was consistent with some purification but the sample was still a mixture. However, ¹³C shifts for **75** which were

consistent with authentic samples of **75•2I⁹²** observed by ¹³C NMR (DMSO-*d*₆): ¹³C NMR (DMSO-*d*₆, 90.56 MHz, ref central line of DMSO-*d*₆ set at 39.5) δ 43.18, 50.91, 148.24.

Attempted Diels-Alder Reaction of 2,3,5,6,8,9-Hexahydrodiimidazo [1,2-a:2',1'-c]pyrazine (16) and N-Phenylmaleimide.

2,3,5,6,8,9-Hexahydrodiimidazo[1,2-a:2',1'-c]pyrazine (**16**) (0.10 g, 0.61 mmol) was dissolved in warm toluene (10 mL). The temperature was maintained above 40°C in order to keep the bisamidine in solution. A solution of N-phenyl maleimide (0.11 g, 0.63 mmol) in toluene (10 mL) was added via an addition funnel over 2 minutes. The heat was increased until everything went into solution (50 °C) and the reaction mixture was stirred for 0.5 h. An aliquot (2 mL) was removed and O₂ was bubbled through the solution. No fluorescence was observed. The solvent was removed by rotary evaporation to afford an orange solid. The solid was not completely soluble in C₆D₆. NMR analysis showed that only bisamidine starting material had dissolved in C₆D₆. The material that did not dissolve in C₆D₆ was soluble in CDCl₃. NMR analysis of this sample also showed some bisamidine starting material and other minor unknown specie(s) whose NMR spectra were inconsistent with a Diels-Alder adduct of N-phenylmaleimide and the bisamidine. The temperature of the original reaction mixture was increased to 70 °C for 1 h. Another aliquot was removed and concentrated by rotary evaporation. The solid residue was taken up in CDCl₃. NMR data again showed that there was bisamidine starting material in

addition to other resonances which were unidentified. The temperature of the original solution was increased to 105 °C for 4 h. Another aliquot was removed and concentrated by rotary evaporation. NMR analysis of the residue in CDCl₃ did not support product formation and showed bisamidine starting material.

The reaction was repeated on the same scale and concentration. The reaction was left stirring at rt for 36 h before the first aliquot was removed. ¹H NMR analysis showed the two reactants, a broad resonance at 2.6 ppm and broadening in the aromatic region.

***cis*-15-1,4,8,12-Tetraazatetracyclo[6.6.2.0^{4,16}.0^{11,15}]hexadecane (85).** **85** was prepared based on the method of Weisman et al.¹⁰⁵ Aqueous glyoxal (5.34 g, 40 wt % aq. solution; 36.1 mmol) was added to a stirred heterogeneous mixture of 1,4,8,11-tetraazacyclotetradecane (7.22 g, 36.04 mmol) in 525 mL of CH₃CN. The reaction mixture was stirred for 3 hours at 55 °C and then concentrated by rotary evaporation. The residue was suspended in CHCl₃, dried over Na₂SO₄ and the filtrate was concentrated. Sublimation of the residue (80 °C, 0.015 Torr) afforded 6.19 g (77%) of **85**. NMR spectra were consistent with reported spectra.¹⁰⁵

(1RS, 8RS, 15RS, 16RS)-1,8-Dibenzyl-4,11-diaza-1,8-diazoniatetracyclo-[6.6.2.0^{4,16}.0^{11,15}]hexadecane dibromide monohydrate (90). **90** was prepared by the published method.^{103,104} Benzyl bromide (88.75 g, 518.9 mmol) was added in one portion to a stirred solution of *cis*-15-1,4,8,12-tetraazatetracyclo-

[6.6.2.0^{4.16}.0^{11.15}]hexadecane (**85**) (7.93 g, 35.69 mmol) in 150 mL of CH₃CN under N₂. The reaction mixture was stirred for 14 days and afforded 18.19 g (90%) of pure white product. NMR spectra were consistent with reported spectra.¹⁰³

4-11-Dibenzyl-1,4,8,11-tetraazabicyclo[6.6.2]hexadecane (91). **91** was prepared by the published method.^{103,104} NaBH₄ (63.0 g, 1.66 mol) was added in small portions to a stirred solution of (1RS, 8RS, 15RS, 16RS)-1,8-Dibenzyl-4,11-diaza-1,8-diazoniatetracyclo-[6.6.2.0^{4.16}.0^{11.15}]hexadecane dibromide monohydrate (**90**) (18.89 g, 33.5 mmol) in 95% EtOH (900 mL). The reaction mixture was stirred at room temperature for 18 days. Excess NaBH₄ was decomposed by the dropwise addition of 3M HCl (700 mL). The reaction mixture was concentrated by rotary evaporation and the residue was dissolved in H₂O (400 mL). This aqueous solution was adjusted to pH 14 by the addition of KOH (pellets) and extracted with toluene (6×250 mL). The toluene extracts were dried over Na₂SO₄ and concentrated by rotary evaporation to afford 9.29 g (68%) of white solid **91**. NMR spectra were consistent with reported spectra.¹⁰³

1,4,8,11-Tetraazabicyclo[6.6.2]hexadecane (92). **92** was prepared by the literature method.^{103,104} Glacial acetic acid (100 mL) and 10% Pd/C (0.84 g) were added to a hydrogenation flask which was connected to a glass atmospheric hydrogenation apparatus¹⁵⁰ designed for the exclusion of O₂. After flushing the system with N₂, the catalyst was equilibrated for 1 hour under H₂. To this slurry was added

4,11-dibenzyl-1,4,8,11-tetraazabicyclo[6.6.2]hexadecane (**91**) (4.68 g, 11.51 mmol) in glacial acetic acid (10 mL). The reaction mixture was stirred for 24 hours under H₂ at room temperature and, after workup, afforded 2.6 g (98%) of **92** as an oil, which subsequently solidified. NMR spectra were consistent with reported spectra.¹⁰³

4,11-Bis-(N,N'-diethylacetamido)-1,4,8,11-tetraazabicyclo[6.6.2]-hexadecane monohydrate (95). 1,4,8,11-Tetraazabicyclo[6.6.2]hexadecane (**92**) (183.9 mg, 0.812 mmol) was dissolved in CH₃CN (2 mL). K₂CO₃ (0.45 g, 3.3 mmol), KI (0.55, 3.3 mmol), and 2-chloro-N,N-diethylacetamide (483.0 mg, 3.23 mmol) in CH₃CN (2 mL) were added successively and the resulting mixture was stirred at 60°C for 24 hours. The reaction mixture was then concentrated by rotary evaporation and the residue was dissolved in 3M HCl (20 mL). This solution was extracted with toluene (6×25 mL). The aqueous layer was cooled in an ice/H₂O bath, adjusted to pH 14 with KOH (pellets) and extracted with toluene (6×25 mL). The toluene extracts were dried over Na₂SO₄ and the filtrate was concentrated to give 342.1 mg (93%) of waxy solid **95**. mp: 81.5-82.5°C; ¹H NMR (CD₃CN, 360.15 MHz, ref central line of CD₂H₂CN set at 1.94) δ 1.03 (t, 6H, NCH₂CH₃, *J* = 7.1 Hz), 1.12 (t, 6H, NCH₂CH₃, *J* = 7.1 Hz), 1.41 (dm, 4H, NCH₂CH₂CH₂N), 2.20 (br s, H₂O), 2.25-2.60 (m, 4H), 2.34 (XX' of AA'XX', 2H) 2.71 (td, 4H, *J* = 10.5, 3.6 Hz), 2.93 (B of AB, 2H), 3.08-3.42 (m, 4H), 3.12 (AA' of AA'XX', 2H) 3.34 (A of AB, 2H), 3.47-3.57 (m, 2H, NCH₂CH₃), 3.87 (ddd, 2H, *J* = 15.4, 12.0, 4.3 Hz); ¹³C NMR (CD₃CN, 90.56 MHz, ref CD₃CN set at 1.39) δ 13.38,

14.67, 28.74, 40.24, 41.90, 52.67, 55.06, 57.72, 57.78, 58.15, 59.44, 170.83; IR (KBr) 2966, 2917, 2819, 1645, 1469, 1434, 1124, 794, 618 cm^{-1} ; MS (EI) m/z 452.6 (M^+); Anal. Calcd for $\text{C}_{24}\text{H}_{48}\text{N}_6\text{O}_2 \cdot \text{H}_2\text{O}$: C, 61.24; H, 10.71; N, 17.85; Found: C, 61.53; H, 10.59; N, 17.56.

1,8-Bisacetamido-1,4,8,11-tetraazabicyclo[6.6.2]hexadecane (96).

1,4,8,11-Tetraazabicyclo [6.6.2]hexadecane (92) (0.2425 g, 1.071 mmol) was dissolved in CH_3CN (25 mL) in a 50 mL round bottomed flask. Potassium carbonate (0.60 g, 4.3 mmol), potassium iodide (0.71, 4.3 mmol) and α -chloroacetamide (0.4233 g, 4.53 mmol) were added, and the resulting mixture was heated at 60°C under N_2 for 23 hours. The reaction mixture was then concentrated and dissolved in water (15 mL). The pH was increased to 14 by the addition of solid KOH (pellets) while the mixture was cooled in an ice/ H_2O bath. This solution was extracted with CHCl_3 (6 \times 25 mL) and the organic layer was dried over Na_2SO_4 , concentrated by rotary evaporation and taken up in absolute EtOH (25 mL). The EtOH was removed by rotary evaporation affording 0.3501 g (96%) of a waxy solid. The EtOH is necessary to remove CHCl_3 which forms a solvate with the product. Mp $164\text{--}165^\circ\text{C}$ dec.; ^1H NMR (CD_3CN , 360.15 MHz, ref CD_2HCN set at 1.94) δ 1.39-1.64 (m, 4H, $\text{CH}_2\text{CH}_2\text{CH}_2$), 2.33-2.58 (m, 12H), 2.66-2.75 (m, 4H), 2.79 and 3.07 (d, 4H, $J = 16.14$ Hz, A of AB, $\text{NCH}_2\text{CONH}_2$), 2.97-3.08 (AA' of AAXX', 2H, $\text{NCH}_2\text{CH}_2\text{N}$ bridge), 3.99 (ddd, 2H, $J = 12.61, 8.96, 5.17$ Hz), 5.76 (br s, 2H, amide

NH), 6.78 (br s, 2H, amide NH); ^{13}C NMR (CD_3CN , 90.56 MHz, ref CD_3CN set at 1.39) δ 28.29, 54.05, 54.22, 56.93, 57.98, 59.02, 61.01, 175.1; IR (KBr) 3444, 3325, 3248, 3184, 1685, 1651 cm^{-1} ; MS (EI) m/z 340.3 (M^+); Elemental analysis was inconsistent with a stoichiometric hydrate (but was most consistent with the product as $\mathbf{96} \cdot 0.5\text{H}_2\text{O}$). Anal. Calcd for $\text{C}_{16}\text{H}_{32}\text{N}_6\text{O}_2 \cdot 0.5\text{H}_2\text{O}$: C, 54.99, H, 9.52, N, 24.05; Found: C, 54.90; H, 9.18; N, 23.64.

4,11-Bis(2-cyanoethyl)-1,4,8,11-tetraazabicyclo[6.6.2]hexadecane (97).

97 was prepared by the method of Hill.¹⁰³ 1,4,8,11-Tetraazabicyclo[6.6.2]hexadecane (**92**) (199.9 mg, 0.8830 mmol) and freshly distilled acrylonitrile (2 mL) were stirred at ambient temperature under N_2 for 38 hours. The flask was shielded from light during the reaction. The reaction mixture was then concentrated and the residue was taken up in toluene (15 mL). The toluene solution was dried over Na_2SO_4 and the filtrate was concentrated by rotary evaporation to afford 0.28 g (96%) of **97** as an oil. NMR spectra were consistent with reported spectra.¹⁰³

4,11-Bis-(2-carbamoylethyl)-1,4,8,11-tetraazabicyclo[6.6.2] hexadecane

(98). 1,4,8,11-Tetraazabicyclo[6.6.2]hexadecane (**92**) (0.171 g, 0.753 mmol) was dissolved in CH_3CN in a 25 mL round-bottomed flask. Acrylamide (0.108 g, 1.52 mmol) was added and the resulting mixture was stirred under N_2 at room temperature for 21 days.

The reaction mixture was then concentrated by rotary evaporation and the residue was dissolved in water (10 mL). The pH of this solution was adjusted to 14 with solid KOH (pellets) while cooling the flask in an ice/H₂O bath. This aqueous solution was extracted with CHCl₃ (4×15 mL). Subsequent drying of the CHCl₃ extracts over Na₂SO₄ and concentration of the filtrate afforded an oil. Trituration of this oil with Et₂O gave 0.252 g (91%) of **98** as a white waxy solid: mp: 120-122°C; ¹H NMR (CDCl₃, 360.15 MHz, TMS) δ 1.42-1.47 (m, 2H), 1.57-1.70 (m, 2H), 1.68 (s, H₂O), 2.26-3.0 (m, 18H), 4.10 (dt, 2H, *J* = 13.4, 6.9 Hz), 5.50 (br s, 2H), 7.67 (br s, 2H); ¹³C NMR (CDCl₃, 90.56 MHz, ref central line of CDCl₃ set at 77.23) δ 26.61, 33.70, 52.33 (2C's), 53.46, 53.67, 54.66, 55.48, 58.78, 175.41; IR (KBr) 3356, 3184, 1669 cm⁻¹ (C=O); MS (EI) *m/z* 368.5 (M⁺). Elemental analysis was inconsistent with a stoichiometric hydrate (but was consistent with the product).

Attempted Reduction of 4,11-Bis(2-acetamido)-1,4,8,11-

tetraazabicyclo[6.6.2]hexadecane with BH₃•THF. 4,11-Bis(2-acetamido)-1,4,8,11-tetraazabicyclo[6.6.2]hexadecane (**96**) (54.1 mg, 0.1589 mmol) was suspended in THF (8 mL). This mixture was cooled in an ice/H₂O bath prior to the addition of a solution of BH₃•THF (1 M in THF, 2.2 mL, 2.2 mmol) via syringe. This mixture was stirred at 0 °C for 30 minutes and then heated at reflux for 3 hours. The excess borane was decomposed by the dropwise addition of H₂O (1.5 mL). The reaction mixture was concentrated by rotary evaporation, the residue was taken up in HCl (6M)/CH₃OH (1:2, 25

mL) and this solution was heated at reflux for 4 hours. The mixture was then concentrated to approximately 3 mL and diluted with water (10 mL). This solution was adjusted to pH 14 with solid KOH (pellets) and extracted with CHCl_3 (6×25 mL). The extracts were dried over Na_2SO_4 and concentrated to provide 86.1 mg of an oil. The ^1H NMR indicated that reduction had taken place but the product was a complicated mixture. The crude product was dissolved in 6M HCl (20 mL) and the resulting solution was refluxed for 1 hour and then extracted with Et_2O (4×50 mL) and toluene (2×50 mL). These extracts were each dried over Na_2SO_4 and the solvent was concentrated. NMR analyses of these materials did not correspond to the desired product. These two samples totaled 53.6 mg of material. The aqueous layer from these extractions was adjusted to pH 14 and extracted with Et_2O (6×40 mL). These extracts were dried over Na_2SO_4 and concentrated to afford 26.2 mg (50%) of material. The ^1H NMR of this material had a triplet of doublets at ~3.5 ppm and what appeared to be the AX of the AA'XX' expected for the cross-bridge of the product. However, this material was a mixture and conditions for further purification were not found.

Attempted reduction of 4,11-Bis(2-cyanoethyl)-1,4,8,11-tetraazabicyclo[6.6.2]hexadecane (97) with $\text{BH}_3\cdot\text{THF}$. A solution of $\text{BH}_3\cdot\text{THF}$ in THF (1.0 M in THF, 1.5 mL, 1.5 mmol) was added via syringe to a solution of 4,11-bis(2-cyanoethyl)-1,4,8,11-tetraazabicyclo[6.6.2]hexadecane (97) (0.0556 g, 0.1574 mmol) in THF (1 mL) under N_2 . This mixture was heated at reflux for 3 hours.

The reaction mixture was cooled in an ice/H₂O bath prior to the dropwise addition of 6M HCl (7.5 mL). When all of the HCl solution had been added, solid KOH (pellets) were added until the pH had reached 14. This solution was then extracted (6×25 mL) with CHCl₃ and the extracts were dried over Na₂SO₄ and concentrated. NMR analysis of the residue supported incomplete hydrolysis of a boron complex. The residue was dissolved in 3M HCl (30 mL) and this mixture was heated at reflux for 2 hours. The pH of this solution was again adjusted to pH 14 with solid KOH (pellets) and extracted with CHCl₃ to afford 18.8 mg of an oil. The oil was a complicated mixture as determined by NMR analysis.

2-(Tosylamino)ethyl *p*-toluenesulfonate (106). 106 was prepared by the method of Lehn.¹¹⁵ A ~5 °C solution of ethanolamine (50 g, 0.816 mol) and pyridine (140 mL) in CH₂Cl₂ (160 mL) was added dropwise to a solution of *p*-toluenesulfonylchloride (370 g, 1.94 mol) in CH₂Cl₂ (400 mL) which was cooled in an CH₃CN/(dry ice) (~-40 °C) bath. The reaction mixture was stored at -6 °C for 6 days and was then transferred to a separatory funnel. The reaction mixture was washed with H₂O (2×100 mL), 10% HCl (2×250 mL), H₂O (2×500 mL) and dried over Na₂SO₄ and concentrated. The crude product was recrystallized from CCl₄ to afford 90.1 g (30%) of crystalline product. NMR spectra were consistent with reported spectra.¹¹⁵

N-Tosylaziridine (103). 103 was prepared by the method of Lehn.¹¹⁵

2-(Tosylamino)ethyl *p*-toluenesulfonate (10.00 g, 26.75 mmol) was suspended in toluene (100 mL). 3M KOH (40 mL) was added dropwise over 1 hour to this heterogeneous mixture and the resulting mixture was stirred for an additional 2 hours. The layers were then separated and the organic layer was dried over Na₂SO₄ and concentrated. The residue solidified to afford 4.01 g (79%) of **103** as a crystalline white solid. NMR spectra were consistent with reported spectra.¹¹⁵

4,11-Bis(2-(tosylamino)ethyl)-1,4,8,11-tetraazabicyclo[6.6.2]hexadecane

(107). N-Tosylaziridine (**103**) (0.25 g, mmol) and

1,4,8,11-tetraazabicyclo[6.6.2]hexadecane (**92**) (0.14 g, 0.60 mmol) were dissolved in

CH₃CN (25 mL). This mixture was heated at reflux for 3 days under N₂. The reaction

mixture was concentrated by rotary evaporation to afford a yellow oil. This oil was

trituated with Et₂O (15 mL) and afforded a foam upon removal of the Et₂O by rotary

evaporation. ¹³C NMR and MS analysis were consistent with product formation but

conditions for further purification through recrystallization were not found. The ¹H NMR

spectrum (CDCl₃) was dramatically broadened and was very complicated. ¹³C NMR

(CDCl₃, 360.15 MHz, ref CDCl₃ set at 77.23) δ 21.49 (ArCH₃), 25.33 (br,

NCH₂CH₂CH₂N), 40.87, 50.16 (2C's), 53.30 (br), 53.64, 54.08, 55.46 (br), 126.99,

129.56, 138.22, 142.47; MS (EI) *m/z* 620.3 (M⁺).

Attempted Alkylation of *cis*-15-1,4,8,12-tetraazatetracyclo-

[6.6.2.0^{4,16}.0^{11,15}]hexadecane with Bromobutane and 1-[(*p*-tolylsulfonyl)oxy]-2-methoxyethane (109). Approximately 0.2 g of *cis*-15-1,4,8,12-tetraazatetracyclo[6.6.2.0^{4,16}.0^{11,15}]hexadecane were used in each of the six trials. The amine was dissolved in the appropriate solvent prior to the addition of the alkylating agent. Bromobutane was the alkylating agent in all cases except trial #6 where 1-[(*p*-tolylsulfonyl)oxy]-2-methoxyethane (109) was used. Workup involved the removal of the solvent via rotary evaporation. The extent of alkylation or elimination was evaluated by ¹³C NMR in CDCl₃. Trial #3 was also evaluated in D₂O because not all of the reaction products were soluble in CDCl₃. ¹³C NMR analyses of the reaction product mixtures were consistent with either monoalkylation of **85**, or elimination of the alkylating agent and protonation of **85**.

(1RS, 15RS, 16SR)-1-Benzyl-4,8,11-triaza-1-azoniatetracyclo-[6.6.0^{4,16}.0^{11,15}]hexadecane bromide hydrate (111). **131** was prepared by the method of Hill.¹⁰³ Benzyl bromide (2.0 mL, 16.9 mmol) was added in one portion to a stirred solution of *cis*-15-1,4,8,12-tetraazatetracyclo [6.6.2.0^{4,16}.0^{11,15}]hexadecane (**85**) (2.50 g, 11.3 mmol) in toluene (25 mL). The reaction mixture was stirred under N₂ at room temperature for 14 days. The white precipitate was collected by vacuum filtration to afford 2.58 g (58%) of **111**. NMR spectra were consistent with reported spectra.¹⁰³

(1RS, 8RS, 15RS, 16RS)-1-Benzyl-8-methyl-4,11-diaza-1,8-

diazoniatetracyclo[6.6.0^{4,16}.0^{11,15}]hexadecane dihalide (112). 112 was prepared by the method of Hill.¹⁰³ MeI (2.5 mL, 40 mmol) was added to a stirred solution of (1RS, 15RS, 16SR)-1-benzyl-4,8,11-triaza-1-azoniatetracyclo[6.6.0^{4,16}.0^{11,15}]hexadecane bromide hydrate (111) (2.58 g, 6.67 mmol) in CH₃CN (75 mL) in a 250 mL round-bottomed flask. The flask was wrapped in foil to shield the reaction mixture from light and was tightly sealed with a teflon stopcock. After 21 days, a white precipitate was collected by vacuum filtration to afford 3.35 g of product. NMR spectra were consistent with reported spectra.¹⁰³

4-Benzyl-11-methyl-1,4,8,11-tetraazabicyclo[6.6.2]hexadecane (113). 113 was prepared by the method of Hill.¹⁰³ NaBH₄ (13.4 g, 0.354 mol) was added in small portions to a stirred solution of (1RS, 8RS, 15RS, 16RS)-1-benzyl-8-methyl-4,11-diaza-1,8-diazoniatetracyclo[6.6.0^{4,16}.0^{11,15}]hexadecane dihalide (112) (3.35 g) in 95% EtOH (200 mL). The reaction mixture was stirred under N₂ at room temperature for 7 days. The reaction mixture was cooled in an ice/H₂O bath and excess NaBH₄ was decomposed by the addition of 3M HCl (60 mL). The solvent was removed by rotary evaporation. The residue was dissolved in H₂O (150 mL), adjusted to pH 14 with KOH (pellets) and extracted with toluene (6×30 mL). The extracts were dried over Na₂SO₄ and concentrated to afford 1.78 g of 113 as an oil (81% two step yield from 111). NMR spectra were consistent with reported spectra.¹⁰³

1-Methyl-1,4,8,11-tetraazabicyclo[6.6.2]hexadecane (114). **114** was prepared by the method of Hill.¹⁰³ Glacial acetic acid (50 mL) and 10% Pd/C (0.25 g) were added to a hydrogenation flask which was connected to a glass atmospheric hydrogenation apparatus¹⁵⁰ designed for the exclusion of O₂. That catalyst was equilibrated for 1 hour under H₂. To this slurry was added 4-benzyl-11-methyl-1,4,8,11-tetraazabicyclo[6.6.2]hexadecane (**113**) (2.20 g, 6.28 mmol) in glacial acetic acid (20 mL). The reaction mixture was stirred for 24 hours under H₂ at room temperature. The reaction mixture was filtered through celite and the filtrate was concentrated by rotary evaporation. The residue was dissolved in H₂O (40 mL), the pH was adjusted to 14 with KOH (pellets), and this solution was extracted (6×50 mL) with toluene. The extracts were dried over Na₂SO₄ and concentrated to afford 1.13 g (75%) of **114** as an oil. NMR spectra were consistent with reported spectra.¹⁰³

Attempts to Prepare 1-Benzyl-1,4,8,11-tetraazabicyclo[6.6.2]hexadecane (115). Method A: Benzyl bromide (43 μL, 0.3615 mmol) was added to a solution of 1,4,8,11-tetraazabicyclo[6.6.2]hexadecane (**92**) (0.0822 g, 0.3631 mmol) in CH₃CN (2 mL). This mixture was heated at reflux under N₂ for 16 hours. The reaction mixture was concentrated by rotary evaporation and dissolved in H₂O (10 mL). KOH (pellets) were added to increase the pH to 14 and this aqueous solution was extracted (5×10 mL) with CHCl₃. The extracts were dried over Na₂SO₄ and concentrated to afford an oil. ¹³C NMR analysis of this oil was consistent with a mixture of starting material (**92**), monobenzylated

product (**115**), and dibenzylated product (**91**). ^{13}C NMR (CDCl_3 , 90.56 MHz, ref central line of CDCl_3 set at 77.23) for **92**: δ 24.00, 46.16, 50.43, 51.50, 55.70, 59.10; for **91**: δ 28.12, 52.18, 54.84, 56.64, 57.23, 57.74, 60.12 (not including phenyl ring); for **115**: δ 25.97, 27.43, 48.94, 49.10, 49.17, 49.54, 54.31, 54.37, 57.04, 57.95, 58.99, 59.26, 59.74 (not including phenyl ring). **Method B**: Benzyl bromide (12 μL , 0.09 mmol) was added to a solution of 1,4,8,11-tetraazabicyclo[6.6.2]hexadecane (**92**) (0.0214 g, 0.0945 mmol) in toluene (1 mL). This mixture was stirred under N_2 at room temperature for 4 days. A precipitate had formed and was isolated after removal of the supernatant by pipette. The solid was dissolved in H_2O (10 mL) and this solution was adjusted to pH 14 with KOH (pellets) and extracted (5 \times 10 mL) with CHCl_3 . The extracts were dried over Na_2SO_4 and concentrated to afford a white solid. ^{13}C NMR analysis of this white solid was consistent with **91** and not **115**.

4,11-Bis-(2,4-dinitrophenyl)-1,4,8,11-tetraazabicyclo[6.6.2]hexadecane (118). 1,4,8,11-Tetraazabicyclo[6.6.2]hexadecane (**92**) (0.0833 g, 0.390 mmol) was dissolved in CH_3CN in a 25 mL round-bottomed flask. Potassium carbonate (1.14 g, mmol) and 2,4-dinitrofluorobenzene (100 μL , 0.08 mmol) were added and the solution immediately turned yellow. The mixture was heated at reflux for 3 days under N_2 . The reaction mixture was concentrated by rotary evaporation and the residue was dissolved in water (20 mL). The pH was adjusted to 14 by the addition of solid KOH pellets and the solution was extracted with CHCl_3 (4 \times 50 mL). The CHCl_3 extracts were dried over

Na_2SO_4 and concentrated to afford 0.0781 g (36%) of **92** as a crude orange powder. The crude product was further purified by recrystallization from toluene mp (dec): 245°C; ^1H NMR (CDCl_3 , 360.15 MHz, TMS) δ 1.55-1.70 (m, 2H), 1.85-2.00 (m, 2H), 2.45-2.64 (m, 6H), 2.64-2.84 (m, 4H), 3.08-3.17 (m, 2H), 3.20-3.42 (m, 4H), 3.60 (dt, 2H, $J = 13.8, 7.0$ Hz), 4.91-4.99 (m, 2H), 7.04 (d, 2H, $J = 9.5$ Hz, meta to NO_2 's), 8.20 (dd, 2H, $J = 9.5, 2.7$ Hz, ortho and para to NO_2 's), 8.62 (d, 2H, $J = 2.7$ Hz, ortho to NO_2 's); ^{13}C NMR (CDCl_3 , 90.56 MHz, ref central line of CDCl_3 set at 77.23) δ 28.04, 47.76, 51.48, 52.06, 56.10, 57.82, 117.68, 124.07, 127.80, 137.09, 137.66, 148.66; IR (KBr) 3431, 2814, 1607, 1525, 1319 cm^{-1} ; MS (EI) m/z 558.22 M^+ .

4,11-Bis-(*p*-nitrophenyl)-1,4,8,11-tetraazabicyclo[6.6.2]hexadecane (119).

p-Bromonitrobenzene (11.0 g, 54 mmol) and K_2CO_3 (2.5 g, 18 mmol) were added to a solution of 1,4,8,11-tetraazabicyclo[6.6.2]hexadecane (**112**) (0.61 g, 2.69 mmol) in CH_3CN (50 mL). This mixture was heated at reflux under N_2 for 7 days. The reaction mixture was concentrated to afford a solid. This solid was placed in a Soxhlet cup and extracted with Et_2O for 4 hours to remove excess *p*-bromonitrobenzene. The remaining contents of the Soxhlet cup were then extracted for 3 hours with CH_2Cl_2 . The CH_2Cl_2 extracts were dried over Na_2SO_4 and concentrated to afford ~700 mg (~55%) of a yellow powder. NMR analysis of this powder was consistent with **119** with some impurities. Recrystallization with DMF was found to be the best method for purification of this material. Unfortunately, the recovery of the DMF recrystallization was only 34%, which

corresponds to an overall yield of 19% for this reaction. Decomposition point >230 °C; ^1H NMR (CDCl_3 , 360.15 MHz, TMS) δ 1.81-2.01 (m, 4H, $\text{NCH}_2\text{CH}_2\text{CH}_2\text{N}$), 2.48-2.59 (m, 2H), 2.58 (s, 4H), 2.60-2.71 (m, 2H), 2.82-2.93 (m, 4H), 3.37-3.45 (m, 2H), 3.69-3.73 (dm, 2H, $J=15.5$ Hz), 4.02-4.10 (m, 2H), 6.57 (m, XX' of AA'XX', 4H, $J=9.5$ Hz), 8.10 (m, AA' of AA'XX', 4H, $J=9.5$ Hz); ^{13}C NMR(CDCl_3 , 90.56 MHz, ref central line of CDCl_3 set at 77.23) 28.65, 50.59, 53.43, 54.91, 57.57, 58.38, 111.86, 126.18, 137.47, 153.94; IR (KBr) 3417, 2937, 2807, 1600, 1305, 1113 cm^{-1} ; MS (EI) m/z 468.25 M^+ .

Attempted preparation of 4,11-Bis-(*p*-tolyl)-1,4,8,11-

tetraazabicyclo[6.6.2]hexadecane (122). This procedure was modeled on the method for the arylation of amines reported by Buchwald and coworkers.¹²⁵ $\text{Pd}_2(\text{dba})_3$ (5.1 mg, 0.0056 mmol), \pm -BINAP (6.1 mg, 0.0092 mmol), KO^tBu (99.2 mg, 0.8840 mmol), *p*-bromotoluene (81 mL, 0.66 mmol) and 1,4,8,11-tetraazabicyclo[6.6.2]hexadecane (**92**) (51.9 mg, 0.2293 mmol) were suspended in toluene (5 mL) under N_2 in a dried 100 mL Schlenk flask equipped with a reflux condenser and N_2 inlet tube. The reaction mixture was heated at 100 °C for 14 days. An aliquot (~1 mL) was removed and filtered through a Celite pad. The filtrate was extracted (5 \times 20 mL) with 3M HCl. The aqueous extracts were concentrated, taken up in H_2O (10 mL), adjusted to pH 14 with KOH (pellets) and extracted with toluene (5 \times 20 mL). The combined toluene extracts were dried over Na_2SO_4 and concentrated to afford an oil. ^{13}C NMR analysis showed that the

oil consisted of a complex mixture. The spectra of the major component of the mixture was consistent with monoarylated product **123**. Separation of the components of this mixture by TLC was attempted, however, conditions were not found which resulted in purification of this mixture.

Attempted preparation of 4-11-diphenyl-1,4,8,11-

tetraazabicyclo[6.6.2]hexadecane (124). *n*-Butyllithium (0.7 mL of 2.25 M in hexane, 1.6 mmol) was added dropwise by syringe to a solution of 1,4,8,11-tetraazabicyclo[6.6.2]hexadecane (**92**) (0.1628 g, 0.7129 mmol) in hexane (5 mL) in a 25 mL Schlenk flask equipped with a reflux condenser and N₂ inlet tube. The reaction slowly became turbid and a white powder precipitated. The solvent was evaporated under N₂ by application of a heat gun to the reaction flask. The white powder was dissolved in THF (5 mL) and bromobenzene (0.7 mL, 6.65 mmol) was added in one portion by syringe. The reaction mixture immediately turned red. The reaction mixture was stirred at room temperature for 24 hours under N₂. H₂O (2 mL) was added dropwise by syringe and the reaction mixture turned from red to light yellow as soon as the initial drop of H₂O reached the reaction mixture. The reaction mixture was concentrated by rotary evaporation and the residue was suspended in H₂O. Dissolution was complete upon the addition of 3M HCl (5 mL). The pH of this solution was adjusted to 14 by the addition of KOH (pellets) and the solution was then extracted (4×25 mL) with benzene. The extracts were dried over Na₂SO₄ and concentrated to afford a yellow oil. NMR analysis showed

that this oil was a complex mixture, but there was no evidence for the presence of starting material (92).

***cis*-1,2,3,3a,4,5,5a,6,7,8,8a,12b,12c,12d-Tetradecahydro-**

3a,5a,8a,12a-tetraazabenz[e]pyrene (125). Benzocyclam (34) (1.37 g, 5.07

mmol) was dissolved in CH₃CN (100 mL) in a 250 mL round-bottomed flask. Aqueous glyoxal (0.087 g, 40 wt % aq. solution, 6.0 mmol) was added in one portion. The reaction mixture was heated at reflux for 3 hours under N₂. The reaction mixture was then concentrated by rotary evaporation and taken up in CHCl₃ (50 mL). This solution was dried over Na₂SO₄ and concentrated to afford a brown viscous oil. Sublimation (0.01 Torr/ 150 °C) provided 1.22 g (89%) of 125 as a white crystalline solid: mp:131-132°C; ¹H NMR (Acetone-*d*₆, 360.15 MHz, ref central line of CHD₂COCD₃ set at 2.05, 25°C) δ 1.28-1.37 (dm, 2H, *J* = 13.4 Hz), 2.02-2.15 (m, 2H), 2.24 (td, 2H, *J* = 8.9, 3.4 Hz), 2.62 (br app t, 2H, *J* = 11.4 Hz), 2.77-2.93 (m, 4H), 3.05 (br s, 2H), 3.77 (s, 2H), 4.02-4.08 (dm, 2H, *J* = 13.1 Hz), 6.56-6.61 (m, 2H, XX' of AA'XX'), 6.70-6.75 (m, 2H, AA' of AA'XX'); ¹³C NMR (Acetone-*d*₆, 90.56 MHz, ref central line of Acetone-*d*₆ set at 29.92, 25°C) δ 21.35, 48.23, 49.68 (very broad), 54.65 (br), 73.65 (br), 113.49, 119.47, 136.28; IR (KBr) 3061, 2937, 2862, 2807, 2766, 1587, 1488, 1285 cm⁻¹; MS (EI) *m/z* 270.2 (M⁺); Anal. Calcd for C₁₆H₂₂N₄: C, 71.08; H, 8.20; N, 20.72; Found: C, 70.76; H, 8.06; N, 20.42.

Reaction of *cis*-1,2,3,3a,4,5,5a,6,7,8,8a,12b,12c,12d-Tetradecahydro-3a,5a,8a,12a-tetraazabenz[e]pyrene with Methyl Iodide. 125 (0.15 g, 0.555 mmol) was taken up in CH₃CN (10 mL) in a 50 mL round-bottomed flask. MeI (0.70 mL, 11.5 mmol) was added by syringe. The flask was capped with a teflon stopcock, sealed with parafilm and the reaction mixture was stirred for 16 d at room temperature in the dark. A white precipitate had formed after 16 d. The solvent was removed by pipette to leave approximately 25-50 mg of solid. ¹H NMR (D₂O) of this material was consistent with a dimethylated product but there were impurities present. Recrystallization from CH₃CN afforded purified material. ¹H NMR data supports the formation of 126a. The ¹³C NMR did not have high enough signal to noise in order to support or disprove this hypothesis: ¹H NMR (D₂O, 360.15 MHz, secondary ref CH₃CN set at 2.05) δ 1.89-1.98 (dm, 1H, *J* = 15.8 Hz, NCH₂CH_{eq}HCH₂N), 2.14-2.23 (dm, 1H, *J* = 15.7 Hz, NCH₂CH_{Heq}CH₂N), 2.41-2.65 (m, 2H, NCH₂CH₂*ax*CH₂N), 2.94 (td, 1H, *J* = 12.2, 3.6 Hz), 3.32 (s, 3H, CH₃), 3.44-3.49 (m, 1H), 3.64 (s, 3H, CH₃), 3.64-3.73 (m, 1H), 3.78-4.06 (m, 5H), 4.16-4.25 (tm, 1H), 4.26-4.32 (dm, 1H), 4.39-4.45 (dm, 1H), 4.74-5.02 (m, 2H), 5.22 (s (br), 1H, NCHN), 5.85 (d (br), 1H, NCHN, *J* = 2.1 Hz), 6.82-7.23 (m, 4H, ABCD).

Reaction of *cis*-1,2,3,3a,4,5,5a,6,7,8,8a,12b,12c,12d-Tetradecahydro-3a,5a,8a,12a-tetraazabenz[e]pyrene with Benzyl Bromide. 125 (0.1080 g, 0.4009 mmol) was dissolved in toluene (10 mL) in a 50 mL round-bottomed flask. Benzyl bromide (71 μL, 0.60 mmol) was added via syringe. The reaction mixture was stirred at rt

under N₂ in the dark for 14 d. The reaction mixture was then concentrated by rotary evaporation to give 0.1307 g (74%) of crude **129** as a tan powder. NMR analysis of this powder was consistent with **129**: ¹H NMR (CDCl₃, 360.15 MHz, TMS) δ 1.40-1.44 (dm, 1H, NCH₂CHH_{eq}CH₂N, *J* = 12.5 Hz), 1.92-2.23 (m, 3H), 2.86-2.95 (m, 2H), 3.13-3.50 (m, 5H), 3.69-3.80 (m, 2H), 4.03-4.06 (m, 1H), 4.24 (td, 2H, *J* = 12.2, 3.3 Hz), 4.62 (td, 2H, *J* = 13.1, 4.0 Hz), 5.25 (s (br), 1H, NCHN), 5.59 (s (br), 1H, NCHN), 5.68 (B of AB, 1H, *J* = 12.5 Hz), 5.99 (A of AB, 1H, *J* = 12.5 Hz), 6.71-6.91 (m, 4H), 7.24-7.46 (m, 3H), 7.73 (d, 2H, *J* = 7.0 Hz); ¹³C NMR (CDCl₃, 90.56 MHz, ref to central line of CDCl₃ set at 77.23) δ 20.35, 20.58, 46.82, 47.16, 47.65, 47.81, 53.96, 58.39, 60.06, 67.86, 114.56, 115.41, 120.26, 121.80, 126.94, 129.24, 130.57, 133.45, 133.66, 133.96.

Complex of 4,11-Bis-(N,N'-diethylacetamido)-1,4,8,11-

tetraazabicyclo[6.6.2]hexadecane (95) with LiClO₄. 4,11-Bis-

(N,N'-diethylacetamido)-1,4,8,11-tetraazabicyclo[6.6.2]hexadecane (**95**) (46.2 mg, 0.1067 mmol) was dissolved in CD₃CN (~1 mL). LiClO₄ (11.6 mg, 0.1090 mmol) was added and NMR spectra were acquired. ¹H NMR (CD₃CN, 360.15 MHz, central line of CD₂H₂CN set at 1.94) δ 1.01 (t, 6H, CH₂CH₃, *J* = 7.1 Hz), 1.51 (t, 6H, CH₂CH₃, *J* = 7.1 Hz), 1.41 (dp, 2H, NCH₂CHH_{eq}CH₂N, *J* = 16.4, 3.1 Hz), 1.97-2.25 (m, 8H), 2.32 (s (br), H₂O), 2.56-2.86 (m, 14H), 3.12-3.44 (m, 16H); ¹³C NMR (CD₃CN, 90.56 MHz, central line of CD₂H₂CN set at 1.39) δ 13.54, 14.69, 26.15, 41.73, 42.44, 53.10,

59.18, 59.75, 61.08, 62.36, 172.2, 174.6, IR (KBr) 1631 cm^{-1} (C=O).

Complex of 4,11-Bis-(N,N'-diethylacetamido)-1,4,8,11-

tetraazabicyclo[6.6.2]hexadecane (95) with NaClO_4 . 4,11-Bis-

(N,N'-diethylacetamido)-1,4,8,11-tetraazabicyclo[6.6.2]hexadecane (95) (26.4 mg,

0.0591 mmol) was dissolved in CD_3CN (~0.7 mL). NaClO_4 (20.3 mg, 0.168 mmol)

was added and NMR spectra were acquired. ^1H NMR (CD_3CN , 360.15 MHz, central line

of CD_2HCN set at 1.94) δ : 1.07 (t, 6H, CH_2CH_3 , $J = 7.1$ Hz), 1.13 (t, 6H, CH_2CH_3 , $J =$

7.1 Hz), 1.45 (dm, 2H, $J = 16.9$ Hz), 1.99-2.07 (m, 2H), 2.08-2.23 (qm, 2H, 16.1 Hz),

2.23-2.35 (m, 2H), 2.33 (s, H_2O), 2.38 (dm, 2H, $J = 12.4$ Hz), 2.48 (dm, 2H, $J = 12.9$

Hz), 2.64-2.82 (m, 3H), 2.86-2.97 (m, 2H), 3.09 (td, 2H, $J = 14.9, 2.8$ Hz), 3.12 (d,

2H, NCHH_BCO , $J = 15.9$ Hz, B of AB), 3.22-3.43 (m, 8H), 3.42 (d, 2H, NCH_ACO , J

$= 15.9$ Hz, A of AB) ^{13}C NMR (CD_3CN , 90.56 MHz, central line of CD_2HCN set at 1.39)

δ 13.29, 14.67, 25.69, 41.72, 42.76, 50.91, 51.33, 58.09, 59.31, 59.89, 60.26, 172.08.

4,11-Bis-(2-carboethoxymethyl)-1,4,8,11-tetraazabicyclo[6.6.2]-

hexadecane (137) complex with LiClO_4 . 4,11-Bis-(2-

carboethoxymethyl)-1,4,8,11-tetraazabicyclo[6.6.2]hexadecane (137) (14.5 mg, 0.0364

mmol) and LiClO_4 (3.9 mg, 0.0364 mmol) were dissolved in CD_3CN (~1 mL) and NMR

spectra were acquired. ^1H NMR (CD_3CN , 360.15 MHz, central line of CD_2HCN set at

1.94) δ 1.21 (t, 6H, CH_2CH_3 , $J = 7.1$ Hz), 1.44 (dp, $\text{NCH}_2\text{CHH}_{eq}\text{CH}_2\text{N}$, $J = 16.6, 3.3$

Hz), 2.02-2.33 (m, 6H), 2.49-2.69 (m, 10H), 2.80-2.98 (m, 6H), 3.11-3.33 (m 2H), 3.23 (d, $NCHH_B CO$, 2H, $J = 18.0$ Hz, B of AB), 3.52 (d, $NCHH_A CO$, 2H, $J = 18.0$ Hz, A of AB), 4.15 (q, 4H, CH_2CH_3 , $J = 7.1$ Hz); ^{13}C NMR (CD_3CN , 90.56 MHz, central line of CD_2HCN set at 1.39) δ 14.47, 25.53, 52.89, 52.99, 59.23, 59.35, 60.39, 62.25, 63.05, 176.58.

4,11-Bis-(2-carboethoxymethyl)-1,4,8,11-tetraazabicyclo[6.6.2]-

hexadecane (137) complex with $NaClO_4$. 4,11-Bis-(2-

carboethoxymethyl)-1,4,8,11-tetraazabicyclo[6.6.2]hexadecane (137) (18.9 mg, 0.0484 mmol) and $NaClO_4$ (5.8 mg, 0.0484 mmol) were dissolved in CD_3CN (~1 mL) and NMR spectra were acquired. 1H NMR (CD_3CN , 360.15 MHz, central line of CD_2HCN set at 1.94) δ 1.27 (t, 6H, CH_2CH_3 , $J = 7.1$ Hz), 1.49 (dm, $J = 17.1$ Hz, $NCH_2CHH_{eq}CH_2N$), 2.03-2.23 (m, 6H), 2.18 (s, H_2O), 2.33-2.42 (m, 2H), 2.47-2.56 (m, 4H), 2.67-2.91 (m, 8H), 3.12 (td, 2H, $J = 16.9, 2.8$ Hz), 3.15 (d, $NCHH_B CO$, 2H, $J = 17.1$ Hz, B of AB), 3.40 (d, $NCHH_A CO$, 2H, $J = 17.1$ Hz, A of AB), 4.14-4.29 (m, 4H, CH_2CH_3); ^{13}C NMR (CD_3CN , 90.56 MHz, central line of CD_2HCN set at 1.39) δ 14.53, 25.72, 51.05, 51.23, 58.28, 59.43, 59.53, 61.31, 62.50, 174.35.

Protonation of 1,4,8,11-tetraazabicyclo[6.6.2]hexadecane (92) with TFA.

1,4,8,11-tetraazabicyclo[6.6.2]hexadecane (92) (28.4 mg, 0.125 mmol) was taken up in CD_3CN (~1 mL). TFA (9.6 μ L, 0.125 mmol) was added via syringe and NMR spectra

were acquired. ^1H NMR (CD_3CN , 360.15 MHz, ref central line of CD_2HCN set at 1.94) δ 1.48-1.57 (m, 2H, $\text{NCH}_2\text{CHHCH}_2\text{N}$), 1.79-1.83 (m, 2H, $\text{NCH}_2\text{CHHCH}_2\text{N}$), 2.55-2.69 (m, 4H), 2.69-3.04 (m, 12H), 3.22 (m, 2H), 7.44 (br s, 3H) ^{13}C (CD_3CN , 90.56 MHz, ref central line of CD_3CN set at 1.39) δ 24.59, 45.26, 48.00, 53.04, 53.91, 57.80.

An equivalent of TFA (9.6 μL , 0.125 mmol) was added and NMR spectra were acquired. There were now two NH resonances which correspond to “inside” and “outside” protons which are in slow exchange. ^1H NMR (CD_3CN , 360.15 MHz, ref central line of CD_2HCN set at 1.94) δ 1.61 (dp, 2H, $\text{CH}_2\text{CHH}_{eq}\text{CH}_2\text{N}$, $J = 10.2, 3.3$ Hz), 2.18 (qt, 2H, $\text{CH}_2\text{CHH}_{ax}\text{CH}_2\text{N}$, $J = 12.5, 4.4$ Hz), 2.38-2.55 (m, 4H), 2.78-2.93 (m, 4H), 3.08-3.52 (m, 10H), 3.52 (m, 2H), 9.27 (br s, 2H), 10.19 (br s, 2H)

100 μL of this sample were removed by syringe. This aliquot was diluted with CD_3CN (1 mL) and NMR spectra were acquired. The spectra did not change as a function of concentration.

D_2O (3 μL) was added via syringe. NMR spectra were immediately acquired but the exchange process had already completed. Therefore, upon addition of a species which can facilitate exchange, “inside” and “outside” protons are rapidly interconverted.

1,4,8,11-Tetraazabicyclo[6.6.2]hexadecane (92) complex with LiClO_4 .

1,4,8,11-Tetraazabicyclo[6.6.2]hexadecane (92) (23.3 mg, 0.103 mmol) and LiClO_4 (10.8 mg, 0.102 mmol) were dissolved in CD_3CN (~1 mL) and NMR spectra were

acquired. The ^{13}C spectrum showed two separate sets of resonances which were consistent with free **92** and $\mathbf{92}\cdot\text{Li}^+$. Additional LiClO_4 (4.3 mg, total LiClO_4 15.1 mg, 0.142 mmol, 1.38 eq.) was added and spectra were acquired. A single set of ^{13}C resonances were observed for this sample that were consistent with $\mathbf{92}\cdot\text{Li}^+$. ^1H NMR (CD_3CN , 360.15 MHz, central line of CD_2HCN set at 1.94) δ 1.34 (dm, 2H, $\text{NCH}_2\text{CHH}_{eq}\text{CH}_2\text{N}$, $J = 16.1$ Hz), 1.86 (br s, 2H, NH), 1.97-2.11 (m, 2H, $\text{NCH}_2\text{CHH}_{ax}\text{CH}_2\text{N}$), 2.20-2.30 (m, 2H), 2.39-2.96 (m, 18H); ^{13}C NMR (90.56 MHz, CD_3CN , central line of CD_2HCN set at 1.39) δ 24.31, 43.52, 48.35, 52.38, 59.75, 60.76.

Attempted Complexation of 1,4,8,11-Tetraazabicyclo[6.6.2]hexadecane (92) with NaClO_4 . 1,4,8,11-Tetraazabicyclo[6.6.2]hexadecane (**92**) (20.1 mg, 0.0888 mmol) and NaClO_4 (10.9 mg, 0.0889 mmol) were dissolved in CD_3CN (~1 mL). The ^1H spectrum was consistent with free **92**. However, the chemical shifts for the ^{13}C resonances were slightly different than the chemical shifts for free **92**. Furthermore, the lines were slightly broadened. These data suggest that there is rapid exchange of Na^+ but **92** is the more abundant species in solution. ^{13}C NMR (CD_3CN , 90.56 MHz, ref central line of CD_3CN set at 1.39) δ 25.34, 46.72, 51.21, 56.55, 59.65.

1-Methyl-1,4,8,11-tetraazabicyclo[6.6.2]hexadecane (114) complex with LiClO_4 . 1-Methyl-1,4,8,11-tetraazabicyclo[6.6.2]hexadecane (**114**) (41.2 mg, 0.1714

mmol) and LiClO_4 (18.4 mg, 1.95 mmol) were dissolved in CD_3CN (870 μL) and NMR spectra were acquired. This sample had a ^{13}C NMR spectrum having thirteen resonances consistent with $114\cdot\text{Li}^+$. ^1H NMR (CD_3CN , 360.15 MHz, ref central line of CD_2HCN set at 1.94) δ 1.34 (dm, 1H, $\text{NCH}_2\text{CHHeqCH}_2\text{N}$, $J = 16.4$ Hz), 1.49 (dp, 1H, $\text{NCH}_2\text{CHH}'\text{eqCH}_2\text{N}$, $J = 16.4, 3.02$ Hz), 1.78 (br dd, 1H, $J = 13.9, 3.9$ Hz), 1.9 (br s, 1H, NH), 2.01-2.40 (m, 8H), 2.52-3.16 (m, 16H); ^{13}C NMR (CD_3CN , 90.56 MHz, ref to CD_3CN set at 1.39) δ 23.84, 24.68, 43.40, 45.59, 47.95, 51.81, 52.16, 52.54, 58.86, 59.19, 59.63, 61.52. This sample contained water which was observed in the ^1H NMR spectrum at 2.94 ppm.

1-Methyl-1,4,8,11-tetraazabicyclo[6.6.2]hexadecane (114) complex with NaClO_4 . 1-Methyl-1,4,8,11-tetraazabicyclo[6.6.2]hexadecane (**114**) (51.5 mg, 0.2142 mmol) and NaClO_4 (26.1 mg, 0.2132 mmol) were dissolved in CD_3CN (1390 μL) and NMR spectra were acquired. This sample had a ^{13}C NMR spectrum having twelve resonances, six of which were dynamically broadened. The dynamic broadening results from the exchange of Na^+ between free and complexed **114** at a rate which is intermediate on the NMR time scale. ^1H NMR (CD_3CN , 360.15 MHz, ref central line of CD_2HCN set at 1.94) δ 3.41 (m, 2H), 1.92-2.04 (m, 2H), 2.16-2.28 (m, 4H), 2.36-2.79 (m, 6H), 2.93 (m, 4H); ^{13}C NMR (CD_3CN , 90.56 MHz, ref to CD_3CN set at 1.39) δ 25.42, 25.90, 43.87 (br), 44.91, 49.62 (br), 51.10, 52.04 (br), 53.07 (br), 57.99, 58.33 (br), 59.14, 59.37.

General Method for Competition Experiments

Sample Preparation

All samples were dispensed into 1-dram vials in a N₂ dry bag. CD₃CN was added to one of the vials and transferred repeatedly between all three vials to ensure that mixing was complete. The resulting CD₃CN solution was transferred to a Wilmad #528-PP 5 mm NMR tube. The volume of the sample was estimated by visual comparison to a known volume of acetone placed into an identical NMR tube by syringe (Hamilton 500 μL). The sample was capped and parafilm and spectra were acquired.

NMR Data Acquisition

¹H NMR FIDs were Fourier transformed ten separate times, phase and baseline corrected, and referenced to the central line of the CD₂H₂CN resonance at 1.94 ppm. The same integral file was used for each transformed spectrum. A mean (\bar{x}) K_{rel} was calculated and a 95%

$$S = \sqrt{\sum_i \frac{(x_i - \bar{x})^2}{N-1}}$$

Equation 4.1

$$\mu = \bar{x} \pm \frac{tS}{\sqrt{N}}$$

Equation 4.2

confidence interval was determined using Equations 4.1 and 4.2. The free energy of competition ($\Delta\Delta G^\circ_{298\text{ K}}$) was then calculated.

For ¹³C NMR spectra, an estimation for competitive equilibrium constants (K_{rel} or K_{Li⁺/Na⁺}) was made based on the height or integrated area of the observed resonances.

Alternatively, in the cases where resonances could be integrated, FIDs were Fourier transformed ten separate times, phase and baseline corrected, and referenced to the central line of the CD_3CN resonance at 1.94 ppm. An average competitive equilibrium constant (K_{rel} or $K_{\text{Li}^+/\text{Na}^+}$) (\bar{x}) was then calculated using the integration data from the ten FID's and a 95% confidence interval was determined using Equations 4.1 and 4.2. The free energy of competition ($\Delta\Delta G^\circ_{298\text{ K}}$) was then calculated.

Competition of Li^+ and Na^+ for 95. Method of detection: $^{13}\text{C}\{^1\text{H}\}$ NMR. K_{rel} was estimated by peak height ($95\cdot\text{Li}^+$: 53.10 ppm; $95\cdot\text{Na}^+$: 51.33 ppm). 95 (21.4 mg, 0.0479 mmol), LiClO_4 (5.2 mg, 0.0480 mmol), NaClO_4 (5.6 mg, 0.0457 mmol), CD_3CN (0.78 mL). Signal to noise: 302:1 (53.10 ppm). Chemical shifts are given in Table 3.1.

Competition of 95 and 83 for Li^+ . Method of detection: $^{13}\text{C}\{^1\text{H}\}$ NMR. K_{rel} was estimated by peak height ($95\cdot\text{Li}^+$: 26.15 ppm; $83\cdot\text{Li}^+$: 28.73 ppm). 95 (85.9 mg, 0.1898 mmol), 83 (48.3 mg, 0.1899 mmol), LiClO_4 (20.4 mg, 0.1899 mmol), CD_3CN (1.63 mL). Signal to noise: 63:1 (26.15 ppm). Chemical shifts are given in Table 3.2.

Competition of Li^+ and Na^+ for 137. Method of detection: ^1H NMR. 137 (13.2 mg, 0.0331 mmol), LiClO_4 (3.5 mg, 0.0332 mmol), NaClO_4 (4.1 mg, 0.0331 mmol), CD_3CN (0.79 mL). The observed resonances were: for $137\cdot\text{Li}^+$: δ 3.53 (d, 2H, A of AB); for $137\cdot\text{Na}^+$: δ 3.39 (d, 2H, A of AB).

Competition of 137 and 83 for Li⁺. Method of detection: ¹H NMR. 137 (19.3 mg, 0.0484 mmol), 83 (12.3 mg, 0.0484 mmol), LiClO₄ (5.0 mg, 0.0484 mmol), CD₃CN (0.98 mL). The observed resonances were: for 137•Li⁺: δ 3.53 (d, 2H, A of AB); for 83•Li⁺: δ 1.75 (dd, 2H, NCH₂CHHCH₂N)

Competition of 92 and 83 for Li⁺. Method of detection: ¹³C NMR. K_{rel} was estimated by integration (83•Li⁺: 24.24 ppm (NCH₂CH₂CH₂N); 92•Li⁺: 24.33 ppm (NCH₂CH₂CH₂N); 83: 28.70 ppm (NCH₂CH₂CH₂N); 92: 25.24 ppm (NCH₂CH₂CH₂N)). 92 (11.5 mg, 0.0507 mmol), 83 (12.9 mg, 0.0507 mmol), LiClO₄ (5.5 mg, 0.0507 mmol), CD₃CN (0.85 mL). Chemical shifts are given in Table 3.4. 95 (22.0 mg, 0.0486 mmol) was later added to the sample of 92 and 88. All free 95 was complexed with Li⁺. Free 88, 88•Li⁺ and free 92 were also observed.

Competition of 92 and 88 for Li⁺. Method of detection: ¹³C NMR. K_{rel} was estimated by integration (88•Li⁺: 24.24 ppm (NCH₂CH₂CH₂N); 92•Li⁺: 24.33 ppm (NCH₂CH₂CH₂N); 88: 28.70 ppm (NCH₂CH₂CH₂N); 92: 25.24 ppm (NCH₂CH₂CH₂N)). 92 (22.7 mg, 0.100 mmol), 88 (25.6 mg, 0.100 mmol), LiClO₄ (10.6 mg, 0.100 mmol), CD₃CN (1.18 mL).

A second sample of 92 and 88 was prepared. 92 (9.5 mg, 0.0420 mmol), 88 (10.8 mg, 0.420 mmol), LiClO₄ (4.5 mg, 0.420 mmol), CD₃CN (1.18 mL). Chemical shifts are

given in Table 3.6. **95** (19.0 mg, 0.0421 mmol) was later added to the sample of **92** and **88**. All free **95** was complexed with Li^+ (**95**• Li^+ : 26.15 ppm) and only free **92** and free **88** was observed.

Competition of Li^+ and Na^+ for **114**. Method of detection: ^{13}C NMR. K_{rel} was estimated by peak height (**114**• Li^+ : 23.82 ppm ($\text{NCH}_2\text{CH}_2\text{CH}_2\text{N}$); **114**• Na^+ : 25.45 ppm ($\text{NCH}_2\text{CH}_2\text{CH}_2\text{N}$)). **114** (26.0 mg, 0.1081 mmol), LiClO_4 (11.5 mg, 0.1081 mmol), NaClO_4 (13.2 mg, 0.1078 mmol), CD_3CN (0.81 mL). Chemical shifts are given in Table 3.7.

Competition of **114** and **83** for Li^+ . Method of detection: ^{13}C NMR. K_{rel} was estimated by peak height (**114**• Li^+ : 23.82 ppm ($\text{NCH}_2\text{CH}_2\text{CH}_2\text{N}$); **83**• Li^+ : 24.24 ppm ($\text{NCH}_2\text{CH}_2\text{CH}_2\text{N}$)). **114** (31.7 mg, 0.1543 mmol), **83** (40.3 mg, 0.1584 mmol), LiClO_4 (17.2 mg, 0.1617 mmol), CD_3CN (0.96 mL). Too much LiClO_4 was added. **83**• Li^+ was the most abundant species in solution but **114**• Li^+ was also present. However, no free **83** was detected verifying that a 1:1:1 molar ratio had not been prepared.

Competition of **137** and **95** for Li^+ . Method of detection: ^1H NMR. **137** (14.6 mg, 0.0366 mmol), **95** (16.5 mg, 0.0366 mmol), LiClO_4 (3.9 mg, 0.0367 mmol), CD_3CN (0.89 mL). The LiClO_4 was added to **137** in CD_3CN . **95** was then added. The observed resonances were: for **137**• Li^+ : δ 4.15 (q, 4H, OCH_2CH_3); for **137**: δ 4.07 (q, 4H,

OCH₂CH₃); for **95•Li+**: δ 3.88 (td, 2H). Water contaminated this competition sample.

1,8-Bisacetamido-1,4,8,11-tetraazabicyclo[6.6.2]hexadecane Complex with

Cu(ClO₄)₂. 1,8-Bisacetamido-1,4,8,11-tetraazabicyclo[6.6.2]hexadecane (39.9 mg,

0.1172 mmol) was dissolved in EtOH (5 mL) in a 25 mL round-bottomed flask.

Cu(ClO₄)₂ (46.2 mg, 0.1249 mmol) was added to this solution and the resulting mixture

was heated at reflux for 4 hours under N₂. Upon cooling to room temperature, two

different materials precipitated. One was light blue in color and fluffy, the other was

granular and dark blue in color. These two materials could be attributed to a complex (dark

precipitate) and a polymer (light blue precipitate). EtOH (5 mL) was added and the heating

was continued for 2.5 hours. The reaction mixture was cooled to room temperature and the

supernatant was removed by pipette and filtered through a glass wool plug in a pipette.

The filtrate was placed in a closed chamber designed to allow slow diffusion of Et₂O into

the solution. After 24 hours, a granular solid had precipitated. This solid was dissolved in

95% EtOH (10 mL). Approximately 3 mL of this solution was diluted with 95% EtOH (9

mL) and this solution was put in the Et₂O diffusion chamber. After 5 days, crystals had

formed. These crystals were not suitable for x-ray crystallography. IR (KBr) 1665 cm⁻¹

(C=O); UV-Vis (MeOH, 2.2 x 10⁻³ M) λ = 630.01 nm, ϵ = 24 M⁻¹ cm⁻¹; Anal. Calcd. For

C₁₆H₃₂N₆CuCl₂O₁₀: C, 31.88; H, 5.35; N, 13.94; Found: C, 13.65; H, 5.19; N, 13.71.

Other crystallization attempts with EtOH, 95% EtOH and CH₃CN with Et₂O diffusion

techniques were unsuccessful in affording x-ray quality crystals.

V. Variable Temperature NMR Experiments

Data Acquisition

All DNMR experiments were run on the same sample. *Cis-125* (29.1 mg) was dissolved in Acetone- d_6 (940 μ L). The NMR tube was capped and sealed with parafilm. ^{13}C NMR spectra were acquired using broad-band decoupling with the following spectrometer settings: Spectrum Reference (SR): $\bar{3854.17}$; Sweep Width (SW): 175 ppm (185-10 ppm); Total Data Points (TD): 32; Decoupler Power (PD): 10H. These settings resulted in a Hz/pt ratio of 0.477. The SR was determined by referencing the central line of acetone- d_6 at 29.29 ppm for the probe temperature spectrum. This provided consistency in referencing the DNMR spectra. The temperature was measured by a chemical shift thermometer. The thermometer was a 1:1 mixture of acetone- d_6 and CCl_4 as reported by Led and Petersen.¹⁵¹ The temperature was calculated by solving Equation 4.1 where $\Delta\delta$ is the difference (in Hertz) between the chemical shift of the carbonyl carbon of acetone- d_6 and CCl_4 .

$$T(^{\circ}\text{C}) = 5529.1 - 50.73\Delta\delta \quad (\text{Equation 4.3})$$

The temperature was recorded before (T_A) and after (T_B) the acquisition of each spectrum after allowing the temperature of the chemical shift thermometer to equilibrate for approximately 15 minutes. The two recorded temperatures are listed before the observed chemical shifts for each experiment.

$T_A(^{\circ}\text{C}) = \bar{73.15}$ ($\Delta\delta = 110.4327$ Hz); $T_B(^{\circ}\text{C}) = \bar{71.19}$ ($\Delta\delta = 110.3940$ Hz): δ 20.56, 21.82, 44.10, 47.89, 48.34, 52.28, 54.89, 56.53, 70.81, 75.74, 113.7, 114.1, 119.7, 119.8, 135.0, 137.6.

$T_A(^{\circ}\text{C}) = -50.00$ ($\Delta\delta = 109.9765$ Hz); $T_B(^{\circ}\text{C}) = -49.63$ ($\Delta\delta = 109.9691$ Hz): δ 20.58, 21.87, 44.16, 47.94, 48.36, 52.36, 54.94, 56.58, 70.89, 75.82, 113.6, 114.0, 119.7(b), 134.9, 137.6.

$T_A(^{\circ}\text{C}) = -44.05$ ($\Delta\delta = 109.8592$ Hz); $T_B(^{\circ}\text{C}) = -42.6$ ($\Delta\delta = 109.8299$ Hz): δ 20.57, 21.86, 44.18, 47.96, 48.32, 52.38, 54.90, 56.58, 70.89, 75.78, 113.6, 113.9, 119.6, 134.9, 137.6.

$T_A(^{\circ}\text{C}) = \text{not obtained}$; $T_B(^{\circ}\text{C}) = -34.03$ ($\Delta\delta = 109.6615$ Hz): δ 20.59, 21.85, 44.19, 48.06, 52.28, 54.92, 56.68, 70.91, 75.83, 113.7, 119.6, 135.0, 137.6.

$T_A(^{\circ}\text{C}) = -15.1$ ($\Delta\delta = 109.2879$ Hz); $T_B(^{\circ}\text{C}) = -15.1$ ($\Delta\delta = 109.2879$ Hz): δ 21.20, 48.19, 57(b), 113.6, 119.6.

$T_A(^{\circ}\text{C}) = -10.6$ ($\Delta\delta = 109.2000$ Hz); $T_B(^{\circ}\text{C}) = -10.6$ ($\Delta\delta = 109.2000$ Hz): δ 21.26(b), 48.18(b), 54.35(b), 113.6, 119.6.

$T_A(^{\circ}\text{C}) = +0.9$ ($\Delta\delta = 108.9729$ Hz); $T_B(^{\circ}\text{C}) = +0.5$ ($\Delta\delta = 108.9802$ Hz): δ 21.29, 48.19, 54.52(b), 73.46(b), 113.6, 119.5, 136.3(b).

$T_A(^{\circ}\text{C}) = +15.0$ ($\Delta\delta = 108.6945$ Hz); $T_B(^{\circ}\text{C}) = +15.7$ ($\Delta\delta = 108.6798$ Hz): δ 21.32, 48.23, 54.55(b), 73.66(b), 113.5, 119.5, 136.3.

$T_A(^{\circ}\text{C}) = +25.43$ ($\Delta\delta = 108.4894$): δ 21.35, 48.23, 49.68(b), 54.65, 73.65, 113.5, 119.5, 136.3.

NMR Simulations and Data Manipulation

The DNMR spectra were used in a full line shape analysis of this dynamic process. The

region between 19-23 ppm was used to perform the analysis. Simulated NMR spectra were calculated using the gNMR program.¹³⁰ The chemical shift difference between the nuclei in the absence of exchange was estimated using the -72 °C spectrum. The rate of exchange between the nuclei was assumed to be at or below the slow exchange limit at this temperature. The natural line width ($\Delta\nu_{1/2}$) was estimated to be 2.7 Hz for the calculation. This value was obtained from the average line widths at half height of the Acetone- d_6 peaks at various temperatures. The simulated spectra were manually fitted to each experimental spectrum. This operation was performed using the chemical shift difference of the two nuclei ($\Delta\delta$) in the absence of exchange and varying the rate constant until the calculated spectrum visually matched the experimental spectrum. In some cases it was also necessary

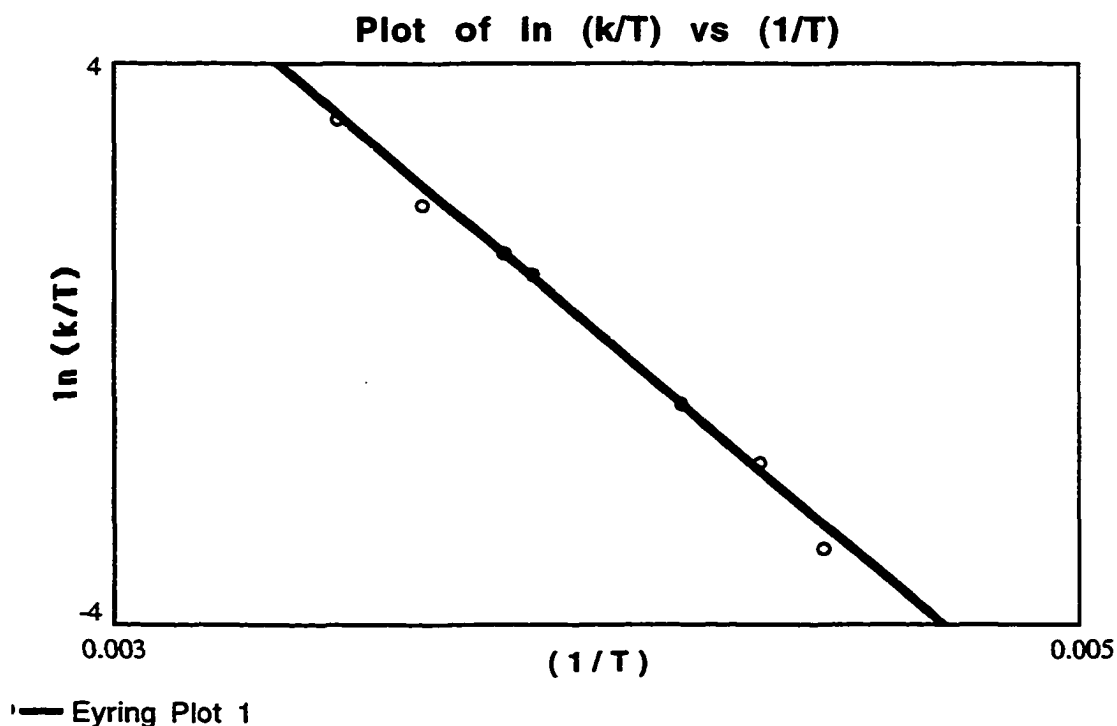

to adjust $\Delta\delta$. The data used in these simulations and the rates which were calculated are given in Table 4.1.

Using the data for the rate obtained from the calculated spectra, an Eyring plot [$\ln(k/T)$ versus $(1/T)$] was generated which allowed for the calculation of ΔH^\ddagger and ΔS^\ddagger .

Table 4.1

Avg. Temp (°C)	T _A	T _B	δ_a	δ_B	$\Delta\delta$	Rate (k) sec ⁻¹
-72.2	-73.2	-71.2	21.81	20.55	114.1	0
-49.8	-50.0	-49.6	21.86	20.58	115.9	12
-43.4	-44.1	-42.6	21.89	20.58	115.9	42
-34.0	-----	-34.0	21.91	20.61	119.5	100
-15.1	-15.1	-15.1	21.91	20.65	114.1	675
-10.6	-10.6	-10.6	21.91	20.65	114.1	950
0.70	0.90	0.50	21.91	20.65	114.1	2000
15.4	15.0	15.7	21.91	20.65	114.1	7000
25.4	25.4	-----	21.96	20.70	114.1	§

Natural line width ($\Delta\nu_{1/2}$): 2.7 Hz

§ Fast exchange limit spectrum

APPENDICES

Submission to Organic Syntheses

1,4,7,10-TETRAAZACYCLODODECANE

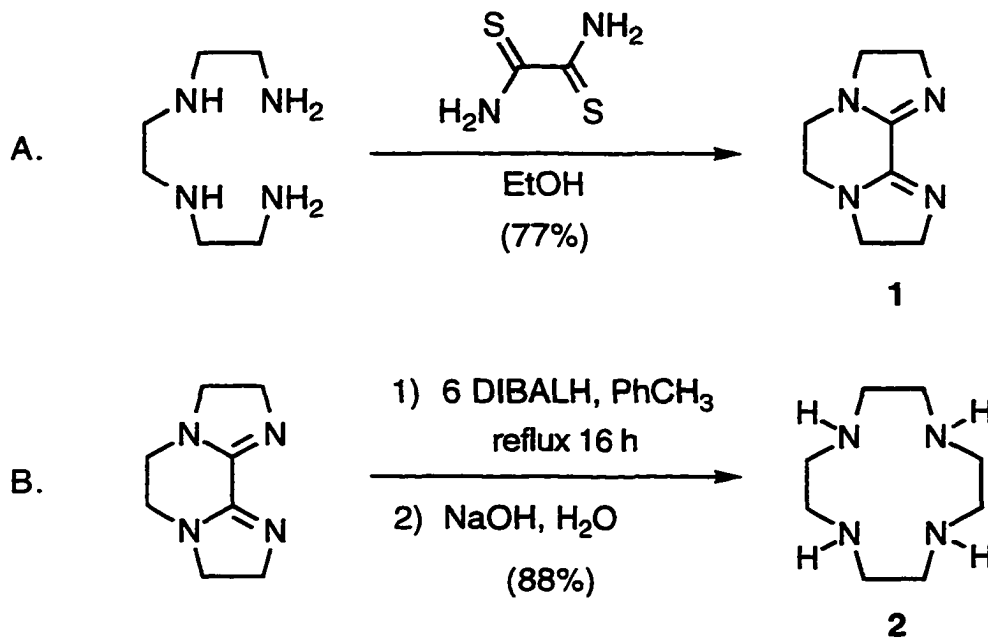

Submitted by David P. Reed and Gary R. Weisman.¹

Checked by _____.

1. Procedure

Caution: Hydrogen sulfide (H_2S) is generated in Part A of this procedure. The reaction and associated operations must be carried out with provision for H_2S trapping in an efficient hood.

A. 2,3,5,6,8,9-Hexahydrodiimidazo[1,2-a:2',1'-c]pyrazine (1). A 500-

mL, three-necked, round-bottomed flask is equipped with a 125 mL pressure-equalizing addition funnel, a Teflon-coated magnetic stirring bar, a fritted gas dispersion tube (initially closed) connected to a nitrogen manifold, and a reflux condenser fitted with a nitrogen inlet tube connected to the nitrogen manifold. The nitrogen manifold exit line is routed through two fritted gas-washing bottles charged with 30% aqueous sodium hydroxide (NaOH) in order to scrub H₂S evolved in the reaction (Note 1). The reaction flask is charged with 10.00 g (83.20 mmol) of dithiooxamide (Note 2) and 50 mL of absolute ethanol. A solution of 12.16 g (83.15 mmol) of triethylenetetramine (Note 3) in 50 mL of absolute ethanol is introduced to the reaction flask in one portion via the addition funnel. The magnetically-stirred reaction mixture is heated to reflux for 4 hours under nitrogen with evolution of H₂S and NH₃ (Note 4). The mixture is then cooled to room temperature and residual H₂S and NH₃ are purged from the reaction mixture for 3 hours by entrainment with nitrogen, which is bubbled through the submerged fritted gas dispersion tube. The reflux condenser is then replaced with a short-path distillation head, solvent is removed by vacuum distillation (water aspirator), and the residue is taken up in 150 mL of chloroform (CHCl₃). Insoluble material is removed by gravity filtration through a glass wool plug inserted in a short-stem glass funnel. CHCl₃ is then removed by rotary evaporation to give 14.18 g of crude product. This solid is taken up in 50 mL of boiling toluene, insoluble impurities are removed by filtration through a glass wool plug, and the flask and funnel are rinsed with a second 50 mL aliquot of boiling toluene (Note 5). The combined filtrates are concentrated to afford 13.66 g of light yellow crystalline product. Sublimation of this material (0.03 mm, 110°C) affords 10.58 g (77%) of pure (>99%) white product (Note 6,7).

B. *1,4,7,10-Tetraazacyclododecane* (2). A 1-L, three-necked, round-bottomed flask charged with 10.58 g (64.43 mmol) of 2,3,5,6,8,9-hexahydrodiimidazo[1,2-a:2',1'-c]pyrazine is equipped with a reflux condenser

fitted with nitrogen inlet tube, 500 mL pressure-equalizing addition funnel, and Teflon-coated magnetic stirring bar. The system is flushed with N₂ prior to cannulation of 250 mL (375 mmol) of 1.5 M diisobutylaluminum hydride (DIBALH) in toluene (Note 8) to the addition funnel. The reaction flask is cooled in an ice/H₂O bath and the DIBALH solution is added to the reaction flask with stirring over 5 minutes. The reaction mixture is then heated at reflux under nitrogen for 16 h (Note 9). The reaction flask is again cooled in an ice/H₂O bath prior to the addition of 200 mL of toluene. Excess DIBALH is quenched by the cautious dropwise addition of 20 mL of 3 M aqueous NaOH solution. When gas evolution has ceased, 350 mL of 3 M aqueous NaOH is added in one portion and the two-phase mixture is transferred to a separatory funnel (Note 10,11). The phases are separated, chipped ice is added to the aqueous phase, and it is further extracted with ice-cold CHCl₃ (6 x 150 mL). The combined organic extracts are dried over Na₂SO₄, filtered, and the solvents are removed by rotary evaporation to afford 10.22 g of white crystalline solid. Sublimation (0.4 mm, 90°C) affords 9.77 g (88%) of product 2 (>98% purity by NMR; Note 12).

2. Notes

1. The nitrogen manifold (Tygon tubing is suitable) is connected as follows, in this order: (a) nitrogen source, (b) T-connector to fritted gas dispersion tube with shutoff valve or clamp, (c) shutoff valve or clamp (enables nitrogen to be routed through fritted gas dispersion tube when closed and dispersion tube is opened), (d) T-connector to nitrogen inlet tube on reflux condenser, (e) safety flask, (f) gas washing bottle #1, (g) gas washing bottle #2, and (h) mineral oil exit bubbler (See Figure 1).

2. Dithiooxamide was purchased from Fluka Chemical Corp.

3. Triethylenetetramine was purchased from Aldrich Chemical Co. as a hydrate. Anhydrous triethylenetetramine must be used in this procedure. The anhydrous tetraamine was obtained by azeotropic distillation of a toluene solution of the commercial hydrate. Analysis by ^1H NMR verified the removal of water, and no further purification was necessary.

4. Dithiooxamide dissolved to give a homogeneous orange solution soon after the initiation of heating.

5. The hot filtration must be carried out quickly to avoid crystallization of product. This step can be omitted, but a second sublimation may then be necessary to obtain product of sufficient purity for reduction to cyclen.

6. **1** has the following physical and spectroscopic properties: mp 149-151°C (lit² mp 150-151°C); ^1H NMR (CDCl_3 , 360 MHz) δ 3.26 (s, 4H), 3.35 (apparent t (XX' of AA'XX'), 4H, $J_{\text{appar}} = 9.6\text{Hz}$), 3.86 (apparent t (AA' of AA'XX'), 4H, $J_{\text{appar}} = 9.6\text{Hz}$); ^{13}C NMR (CDCl_3 , 90.56 MHz) δ 45.3, 52.1, 53.9, 155.4; IR (KBr) 1629 cm^{-1} (C=N); MS (EI) 164.15 (M)⁺; Anal. Calcd for $\text{C}_8\text{H}_{12}\text{N}_4$: C, 58.52; H, 7.37; N, 34.12. Found: C, 58.38; H, 7.55; N, 34.22.

7. Bisamidine **1** is hydrolyzed in water (in minutes to hours depending upon purity). While it is not necessary to handle **1** in a dry atmosphere, it is prudent to store it in a desiccator.

8. DIBALH in toluene (1.5 M) was purchased from Aldrich Chemical Co.

9. A small scale (0.4 g of **1**) reaction with 5 equivalents of DIBALH at reflux for 8 h afforded product in 94% crude yield. However, these conditions gave incomplete reduction and resulted in only a 60% yield of product when the

reaction was scaled up to 10 g of 1. Therefore, the number of equivalents of DIBALH was increased to 6 and the reaction was run for 16 h.

10. A small amount of solid remains undissolved, but this tends to be distributed in the aqueous phase, making filtration at this stage unnecessary.

11. Originally,² a NaF/H₂O workup was used. Soxhlet extraction of the solids generated in the work-up was required to obtain good yields of crude 2. The present aqueous KOH work-up simplifies the procedure and gives comparable or better yields of crude 2.

12. 2 has the following physical and spectroscopic properties: mp 107-109°C (see reference 2 for a discussion of the literature mp of 2); ¹H NMR (CDCl₃, 360 MHz) δ 2.69 (s, 16H), 2.16 (br. s, 4H). ¹³C NMR (CDCl₃, 90.56 MHz) δ 46.11.

Waste Disposal Information

All toxic materials were disposed of in accordance with "Prudent Practices in the Laboratory"; National Academy Press; Washington, DC, 1996.

3. Discussion

The title compound, 2,³ ("cyclen") and its derivatives are important ligands,⁴ some of which have biomedical applications⁵ (for example, as ligand components of MRI contrast agents). Cyclen is commercially available, but quite expensive.⁶

This procedure is a modification of the method originally reported by Weisman and Reed.² In the first reaction of the two-step sequence (Step A), a two-carbon, permanent, covalently-bound template⁷ is introduced by way of dithiooxamide to convert triethylenetetramine to tricyclic bisamidine **1**. Step A is analogous to the synthesis of 2,2'-bi-2-imidazoline reported by Forssell in 1891.⁸ Step B is a double reductive ring expansion, which converts the two amidine (template) carbons of bisamidine **1** to a -CH₂CH₂- unit of **2**. The reaction is conceptually based upon Yamamoto and Maruoka's highly regioselective DIBALH reduction of bicyclic amidines to ring-expanded cyclic diamines.⁹

The advantages of this procedure are: (a) it is short and efficient (68% overall yield), (b) it is atom-economic¹⁰, (c) starting materials are readily available, (d) purifications are simple, and (e) it permits preparation of moderate quantities of product with modest effort. The disadvantages are the production of hydrogen sulfide (*toxic*) in Step A and the required use of DIBALH, an active hydride reducing agent. However, the former can be efficiently trapped and the latter can be handled safely at the reported scale.

There are alternative methods for preparation of cyclen. Since the mid-1970's, the standard method for preparation of cyclen has been one based upon the general Stetter-Richman-Atkins synthesis of macrocyclic polyamines,¹¹ a medium-dilution cyclization approach that utilizes tosyl protection of nitrogen. The cyclen synthesis developed by Richman and Atkins^{11a,b} (5 steps) and related modifications^{2,12} (4 steps), while very reliable, are still labor-intensive sequences that suffer from atom economy and solvent requirement problems. These problems are largely overcome by the shorter approach documented herein. Two additional syntheses of **2** have recently appeared in the patent literature.^{13,14} Both syntheses (each 3 steps) rely upon

carbon templating for preorganization, subsequent cyclization, and final template removal. These procedures may prove superior for large scale production of **2**, since they do not utilize active hydride reducing agents. However, the procedure reported here is very satisfactory for the laboratory-scale preparation of **2**.

1. Department of Chemistry, University of New Hampshire, Durham, NH 03824
2. (a) Weisman, G. R.; Reed, D. P. *J. Org. Chem.* **1996**, *61*, 5186; (b) *Correction: J. Org. Chem.* **1997**, *62*, (14), in press.
3. Stetter, H.; Mayer, K.-H. *Chem. Ber.* **1961**, *94*, 1410.
4. (a) Bradshaw, J.S.; Krakowiak, K.E.; Izatt, R.M. "Aza-Crown Macrocycles"; *The Chemistry of Heterocyclic Compounds*; Taylor, E. C., Series Ed., Wiley: New York, 1993; Vol. 51. (b) Dietrich, B.; Viout, P.; Lehn, J.-M. "Macrocyclic Chemistry"; VCH: Weinheim, 1993.
5. (a) Parker, D. In "Crown Compounds"; Cooper, S. R., Ed. ; VCH: New York, 1992; (b) Jurisson, S.; Berning, D.; Jia, W.; and Ma, D. *Chem Rev.* **1993**, *93*, 1137-1156.
6. Major specialty chemical suppliers' cyclen (**2**) prices: \$214-290 (U.S.) per gram (1997).
7. Hoss, R.; Vögtle, F. *Angew. Chem. Int. Ed. Engl.*, **1994**, *33*, 375.
8. Forssell, G. *Chem. Ber.* **1891**, *24*, 1846.

9. Yamamoto, H.; Maruoka, K. *J. Am. Chem. Soc.* **1981**, *103*, 4186.
10. Trost, B. M. *Science* , **1991**, *254*, 1471.
11. (a) Richman, J.E.; Atkins, T.J., *J. Am. Chem. Soc.* **1974**, *96*, 2268; (b) Atkins, T.J.; Richman, J.E.; Oettle, W.F., *Org. Syn.* **1978**, *58*, 86; (c) Stetter, H.; Roos, E.-E. *Chem. Ber.* **1954**, 566.
12. (a) Vriesema, B.K.; Buter, J.; Kellogg, R.M., *J. Org. Chem.* **1984**, *49*, 110; (b) Chavez, F.; Sherry, A.D., *J. Org. Chem.* **1989**, *54*, 2990.
13. Athey, P., S.; Kiefer, G., E.; Dow Chem. Co: U.S. Pat. 5,587,451, 24 Dec 1996; *Chem. Abstr.* **1997**, *126*: 144300r.
14. Sandnes, R. W.; Vasilevskis, J.; Undheim, K.; Gacek, M.; Nycomed Imaging A/s Norway: PCT Int. Appl. WO 96 28,432, 19 Sept 1996; *Chem. Abstr.* **1996**, *125*: 301031c.

- Insert **Figure 1** here -

Appendix

Chemical Abstracts Nomenclature (Collective Index Number); (Registry Number)

1,4,7,10-Tetraazacyclododecane; (294-90-6)

2,3,5,6,8,9-Hexahydroimidazo[1,2-a:2',1'-c]pyrazine; (180588-23-2)

Dithiooxamide: Ethanedithioamide (12); (79-40-3)

Triethylenetetramine: 1,2-Ethanediamine, N,N'-bis(2-aminoethyl)- (12); (112-24-3)

Diisobutylaluminum hydride: Aluminum, hydrodiisobutyl- (8); Aluminum, hydrobis(2-methylpropyl)- (9); (1191-15-7)

Figure 1

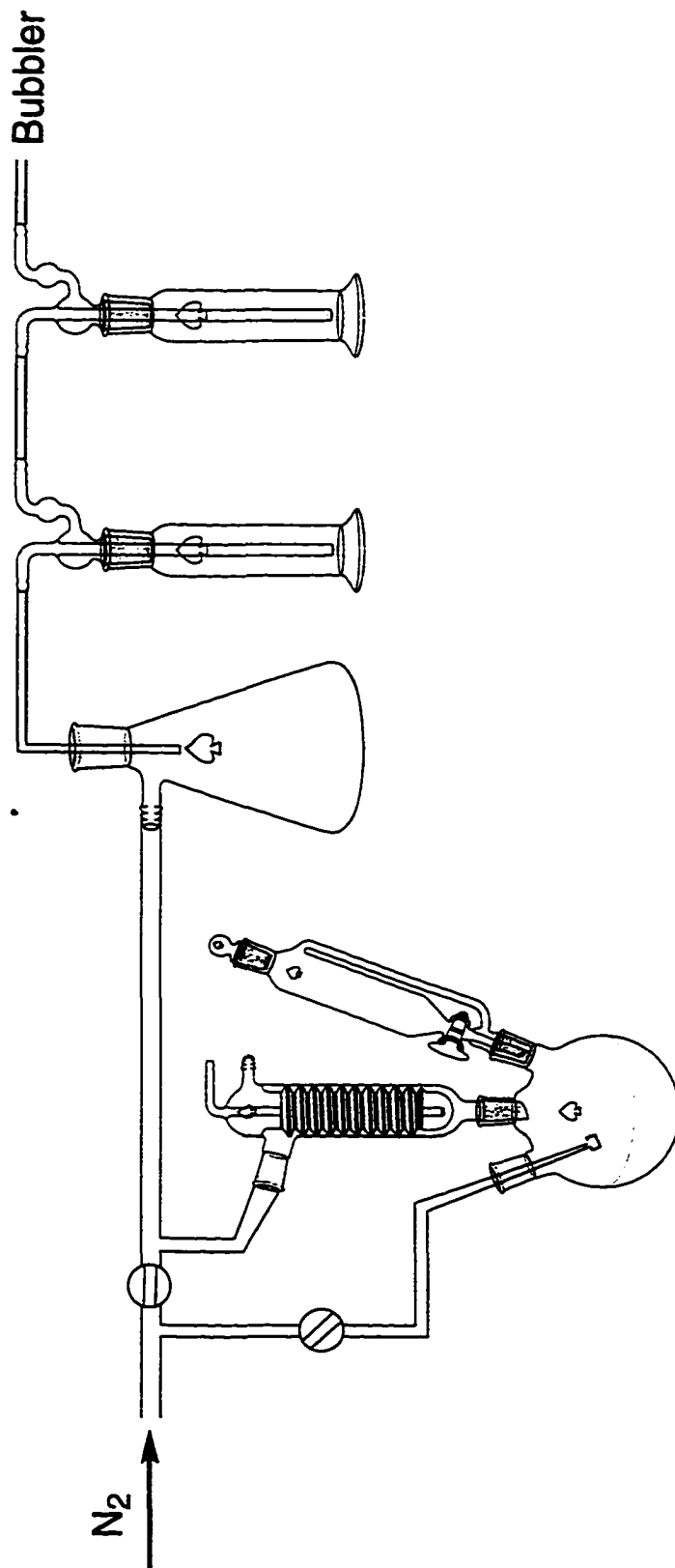

Spectral Appendix

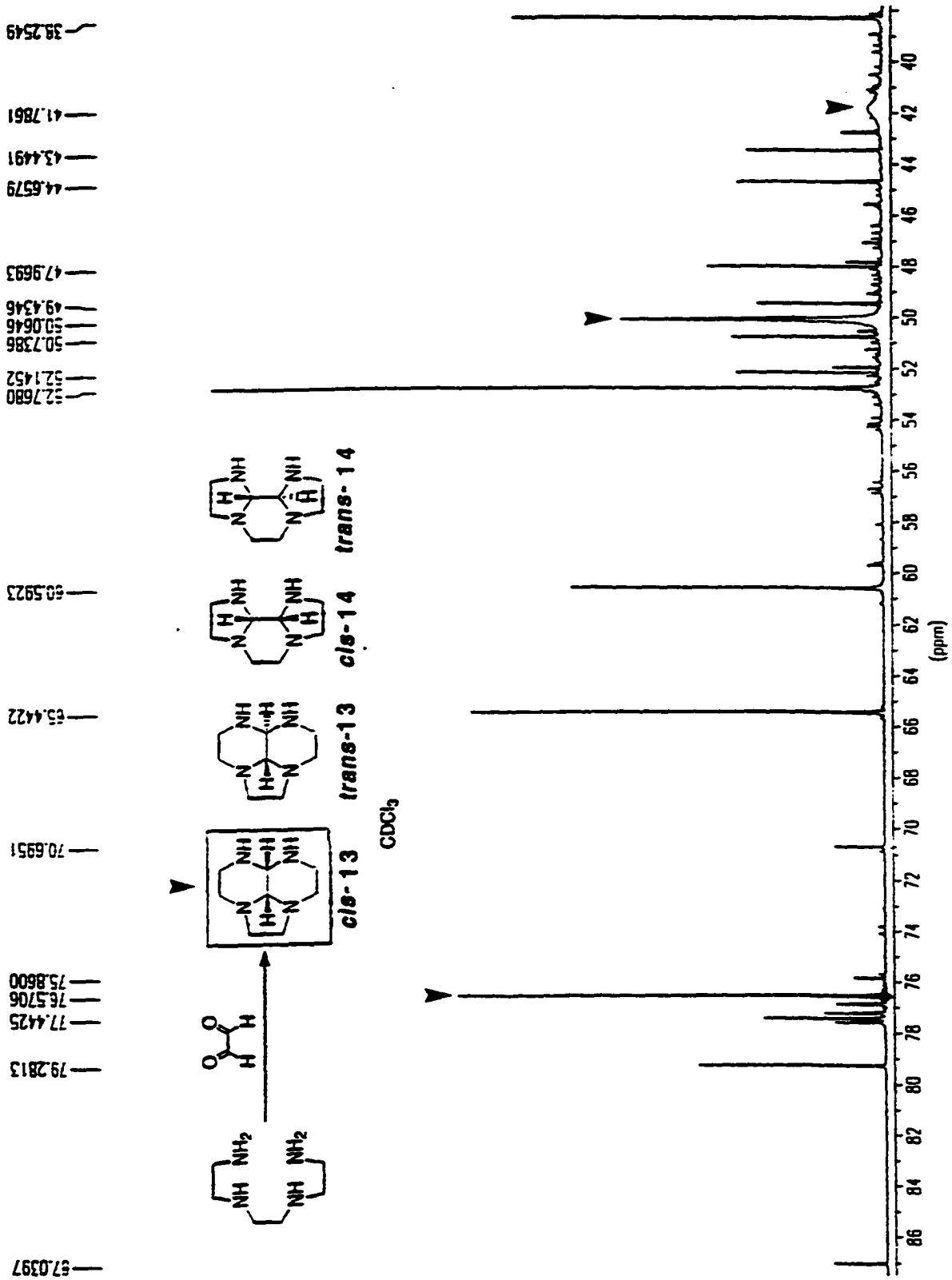

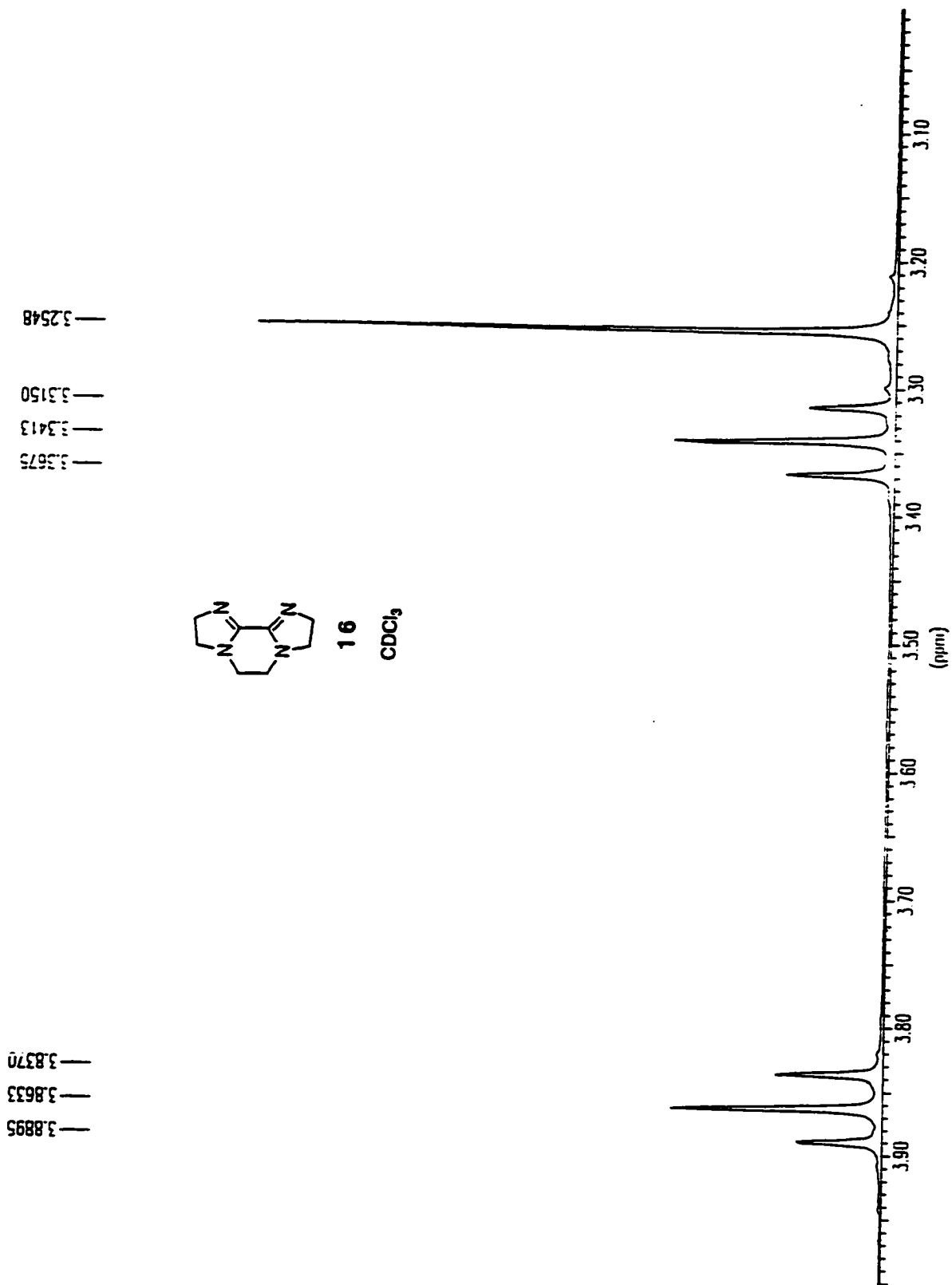

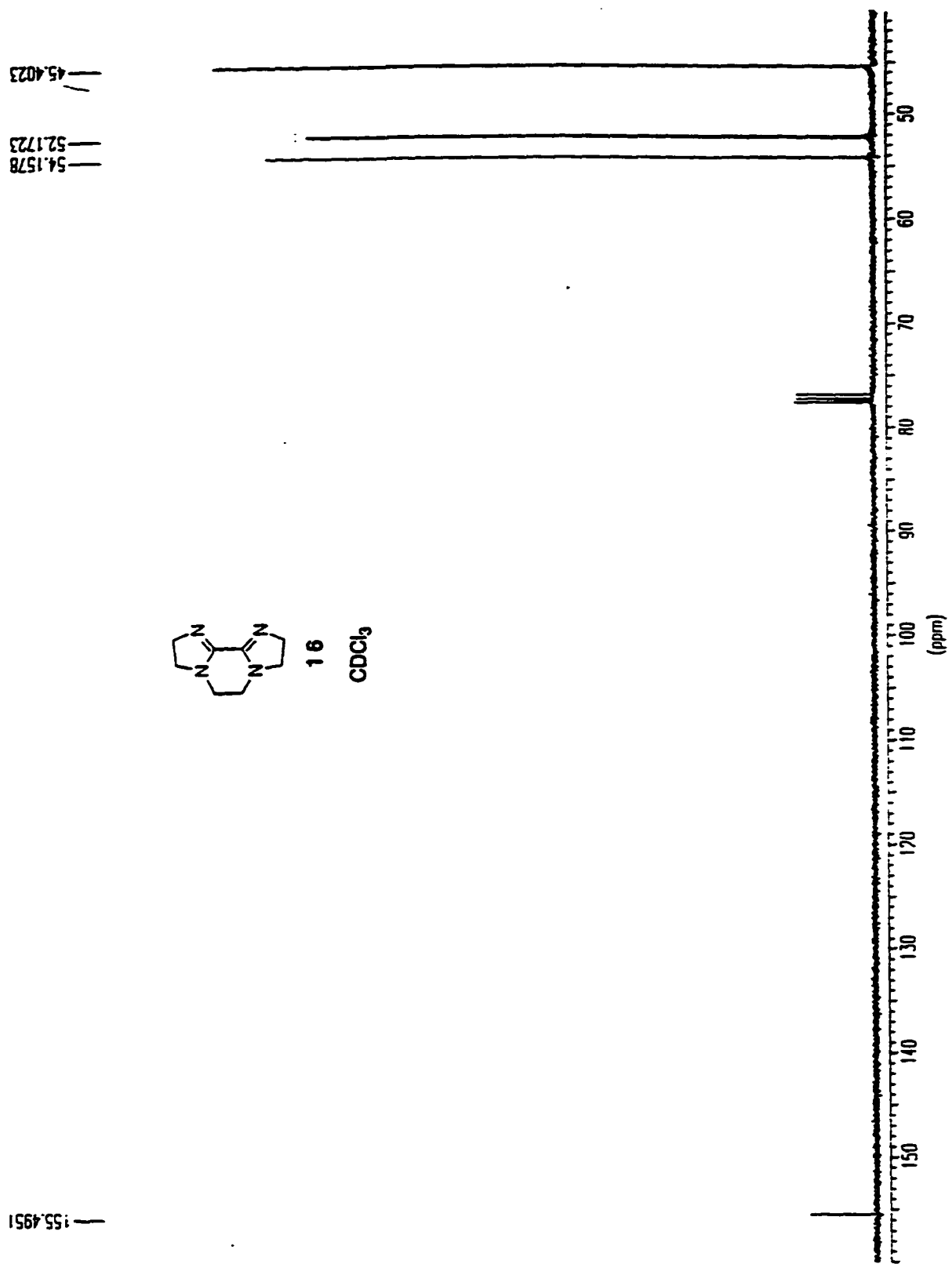

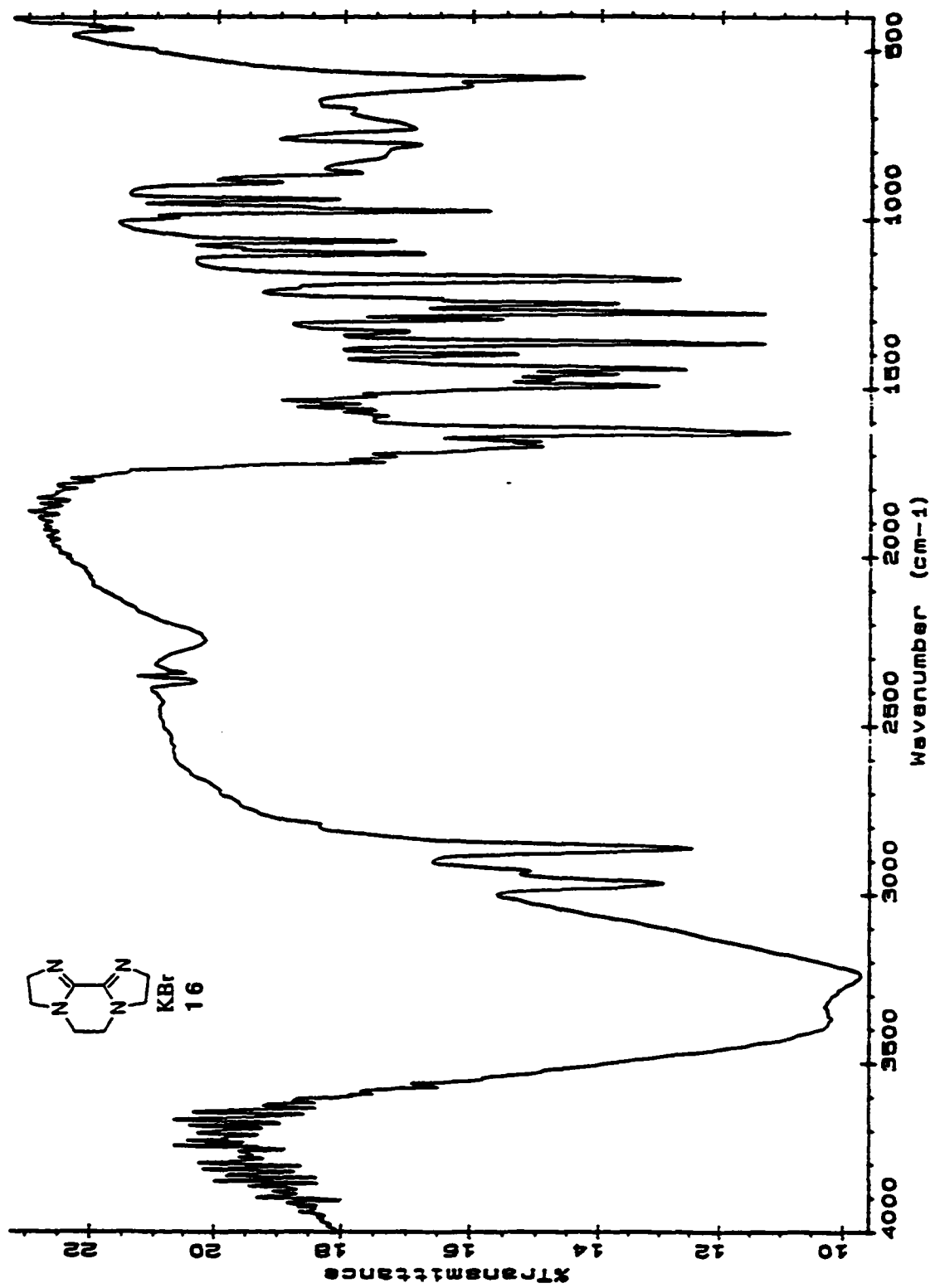

— 1.5990

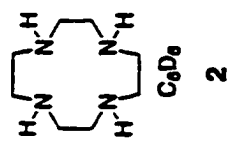

— 2.4566

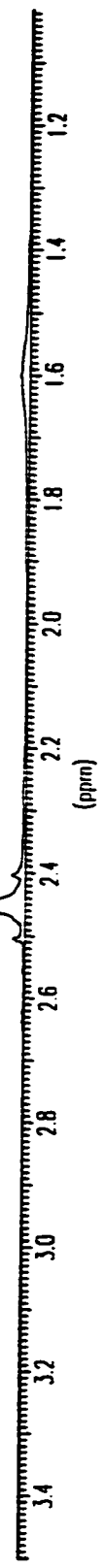

46.9890

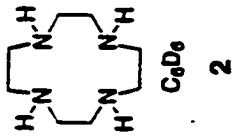

129.3900

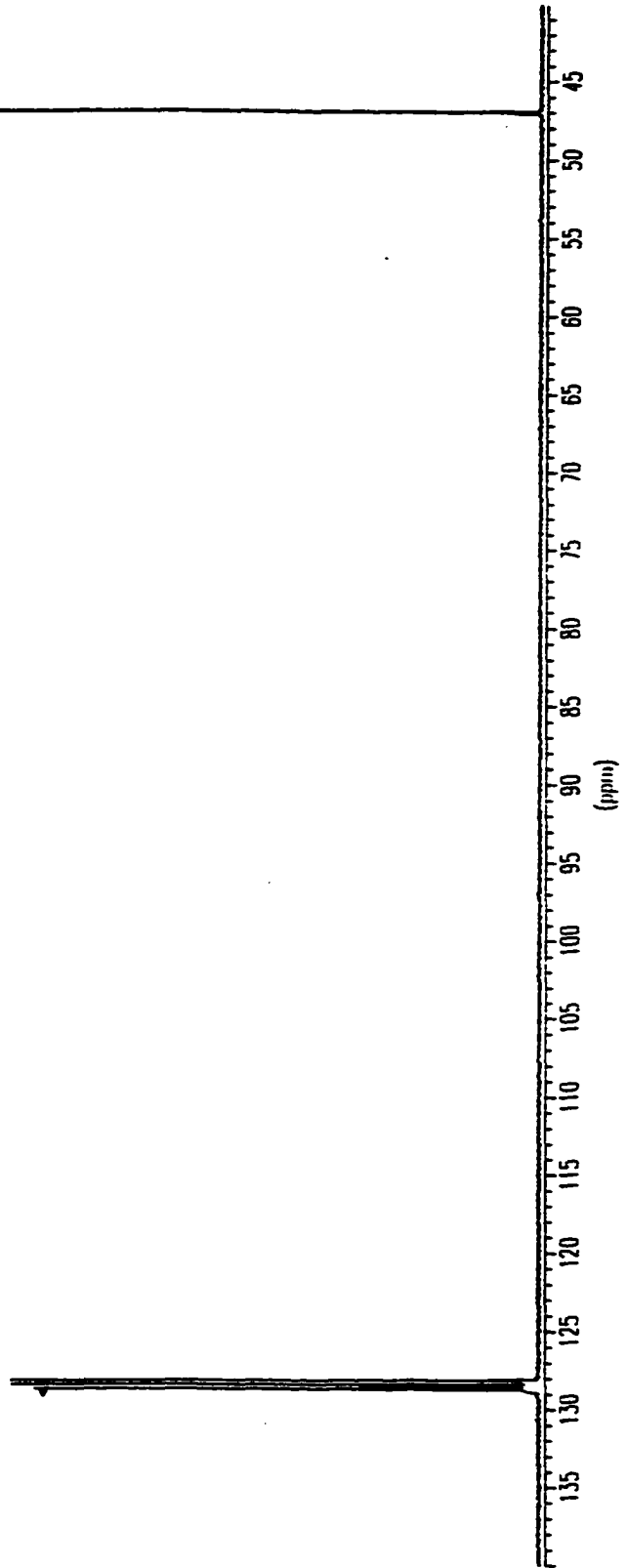

1.9185
1.9024
1.8863
1.8702
1.8533

3.1582
3.1718
3.1879
3.2065
3.2235
3.2396
3.2930
3.3031
3.3286
3.3548
3.5302
3.5463
3.5616
3.7574
3.7836
3.8099

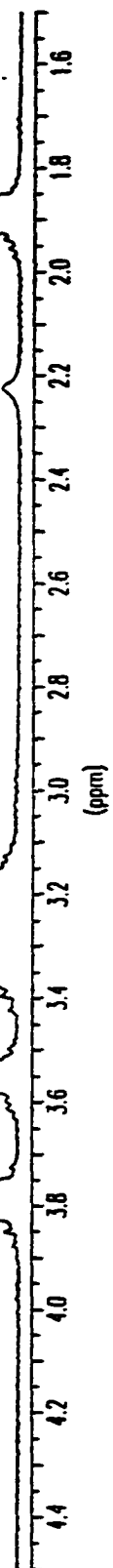
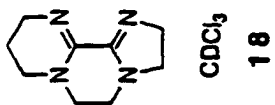

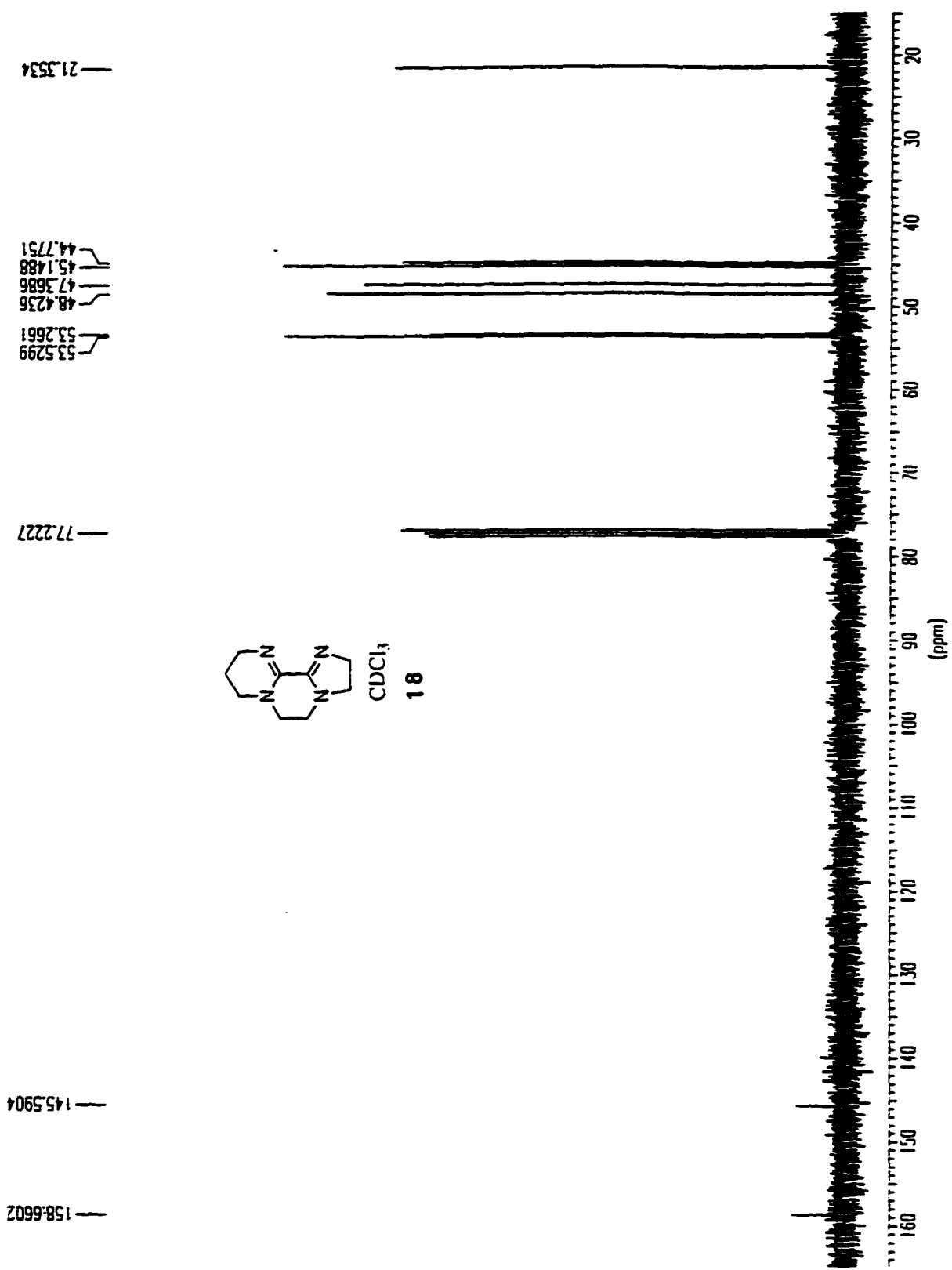

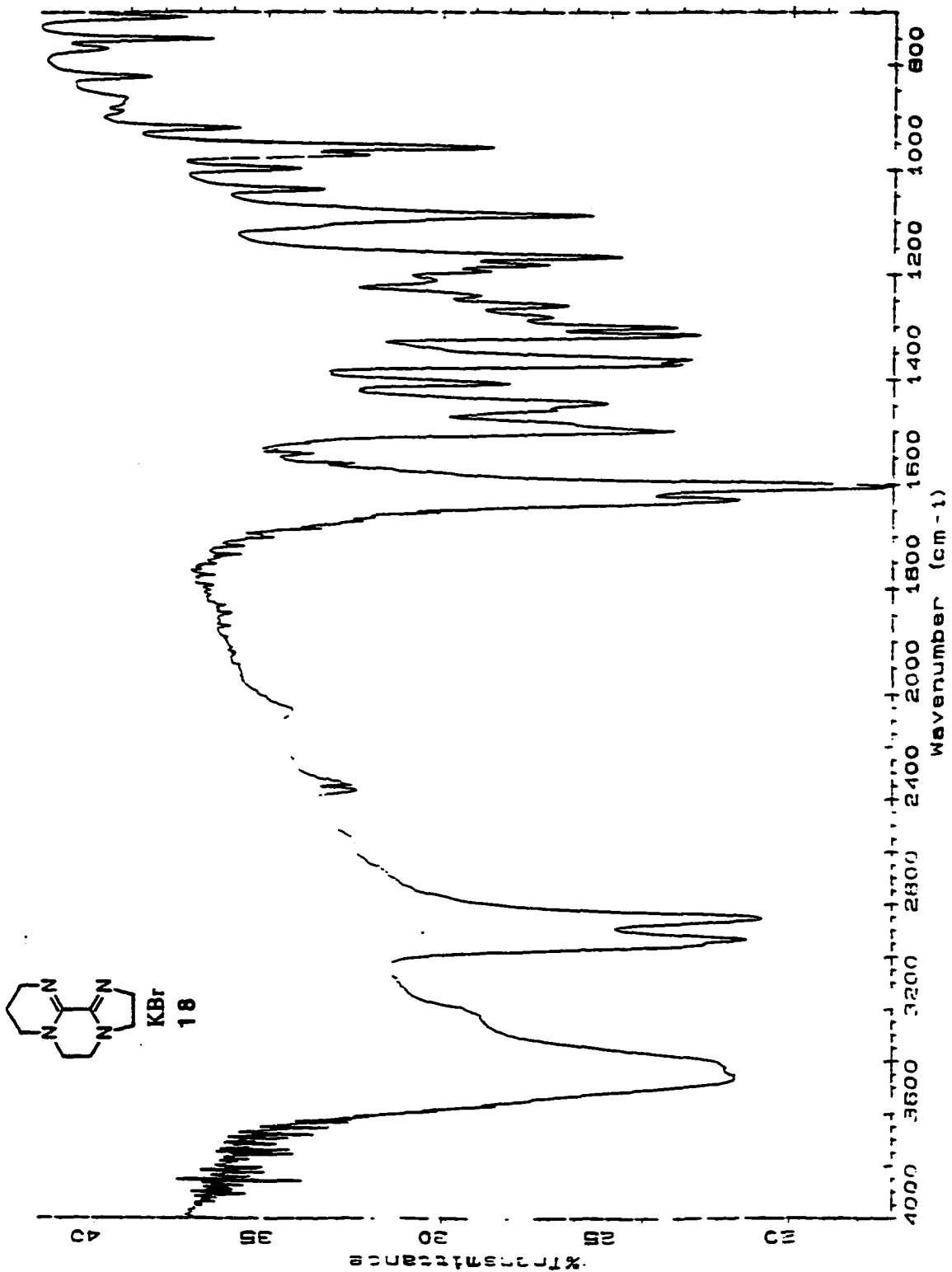

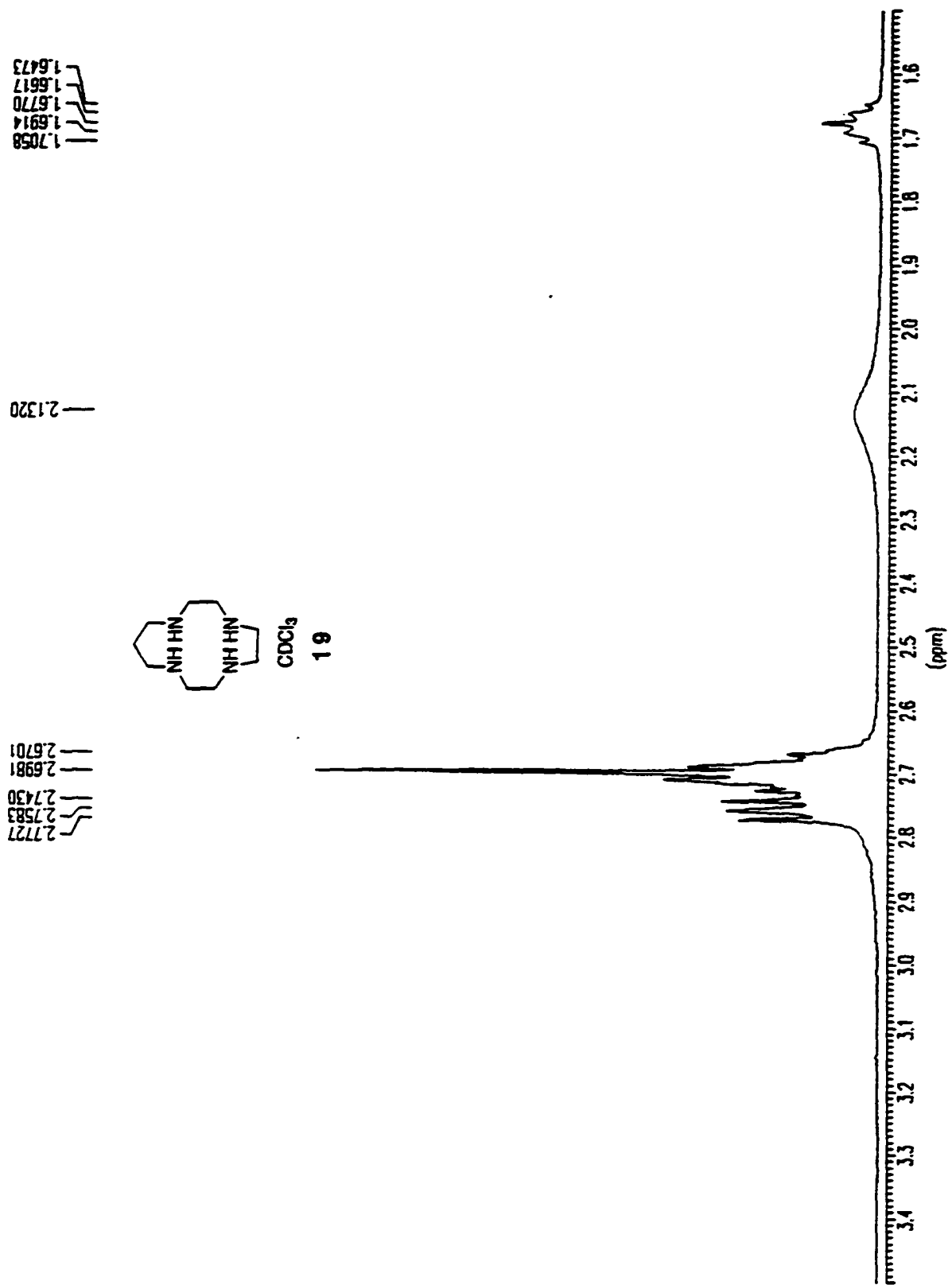

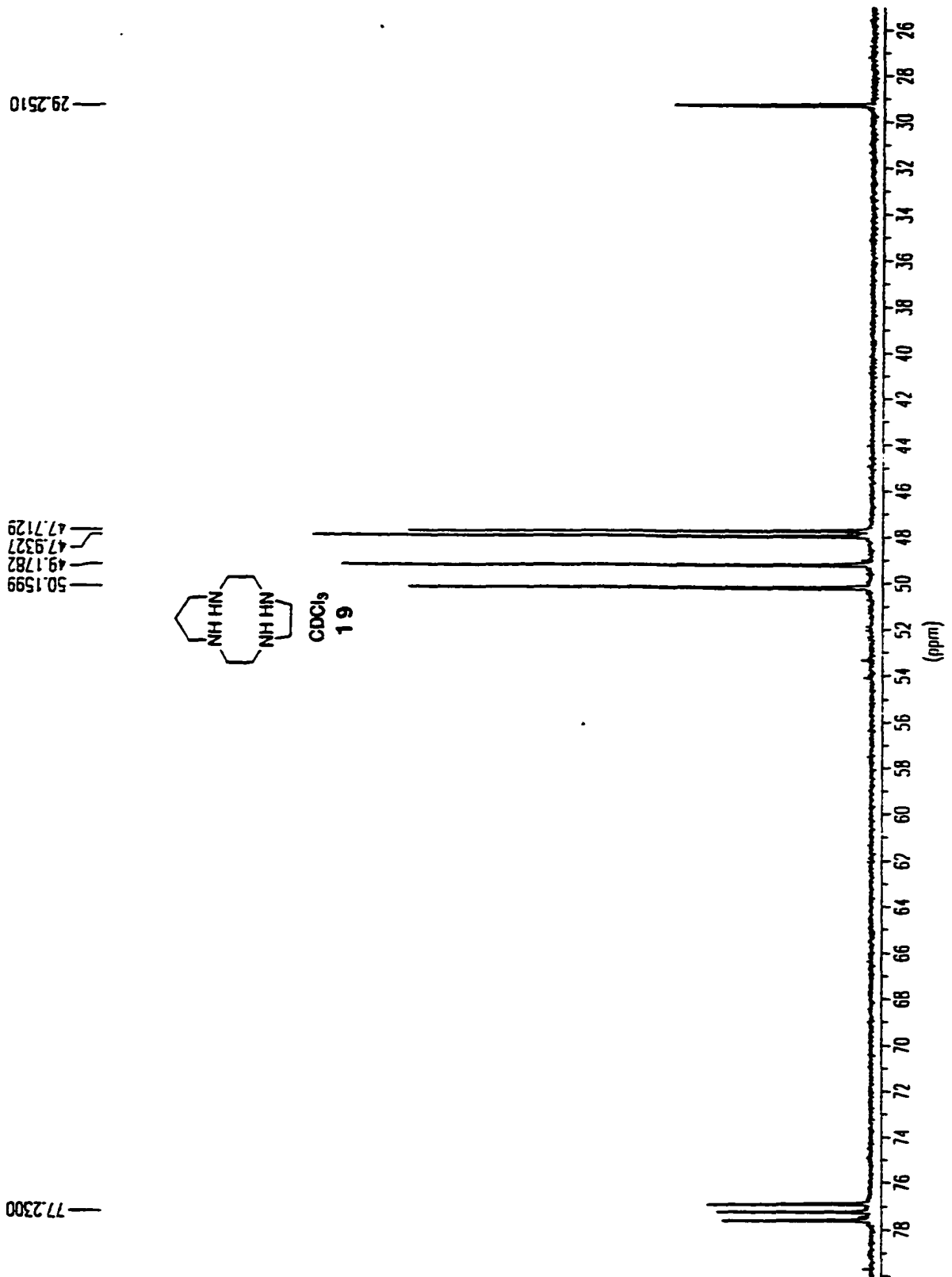

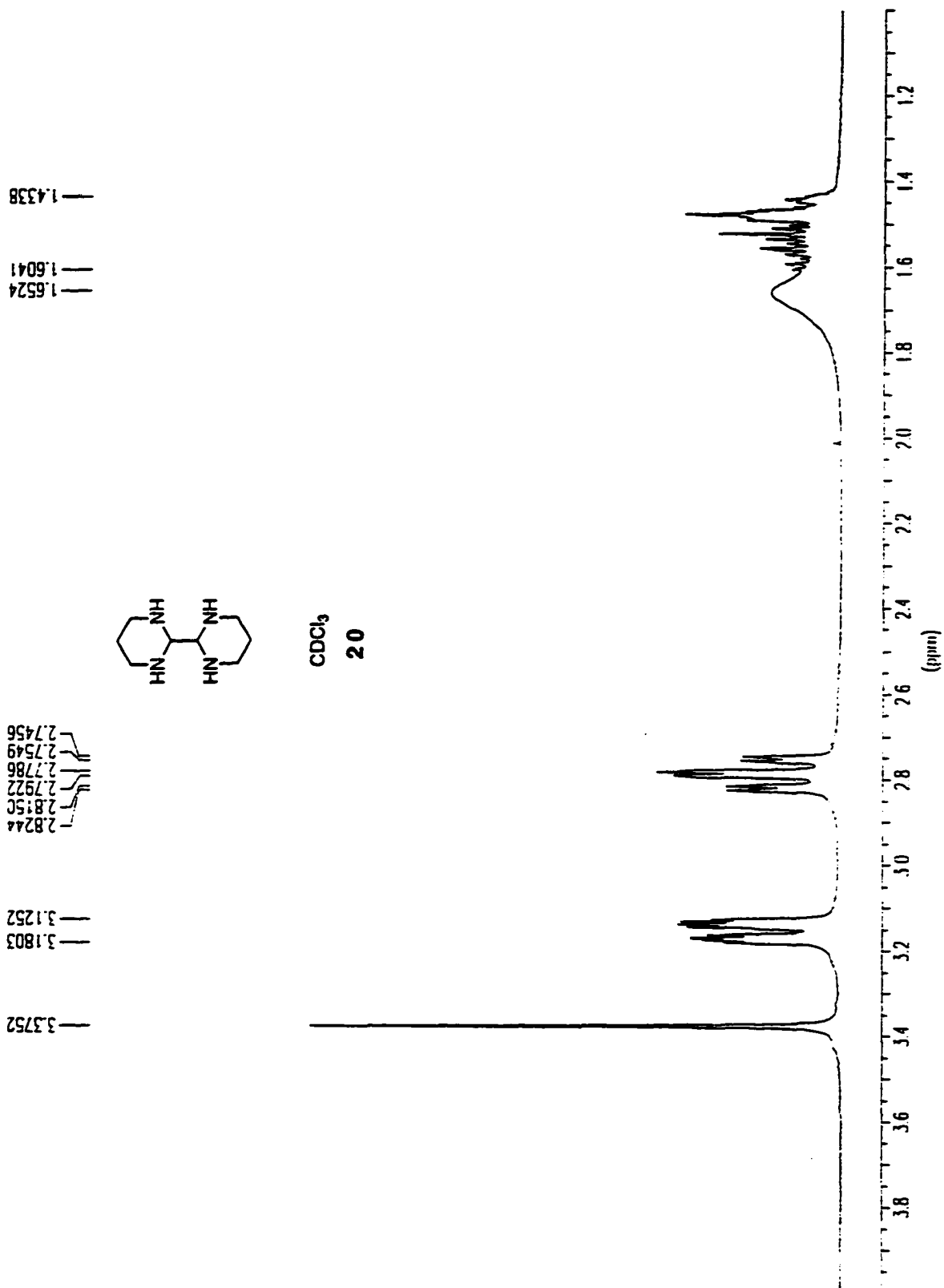

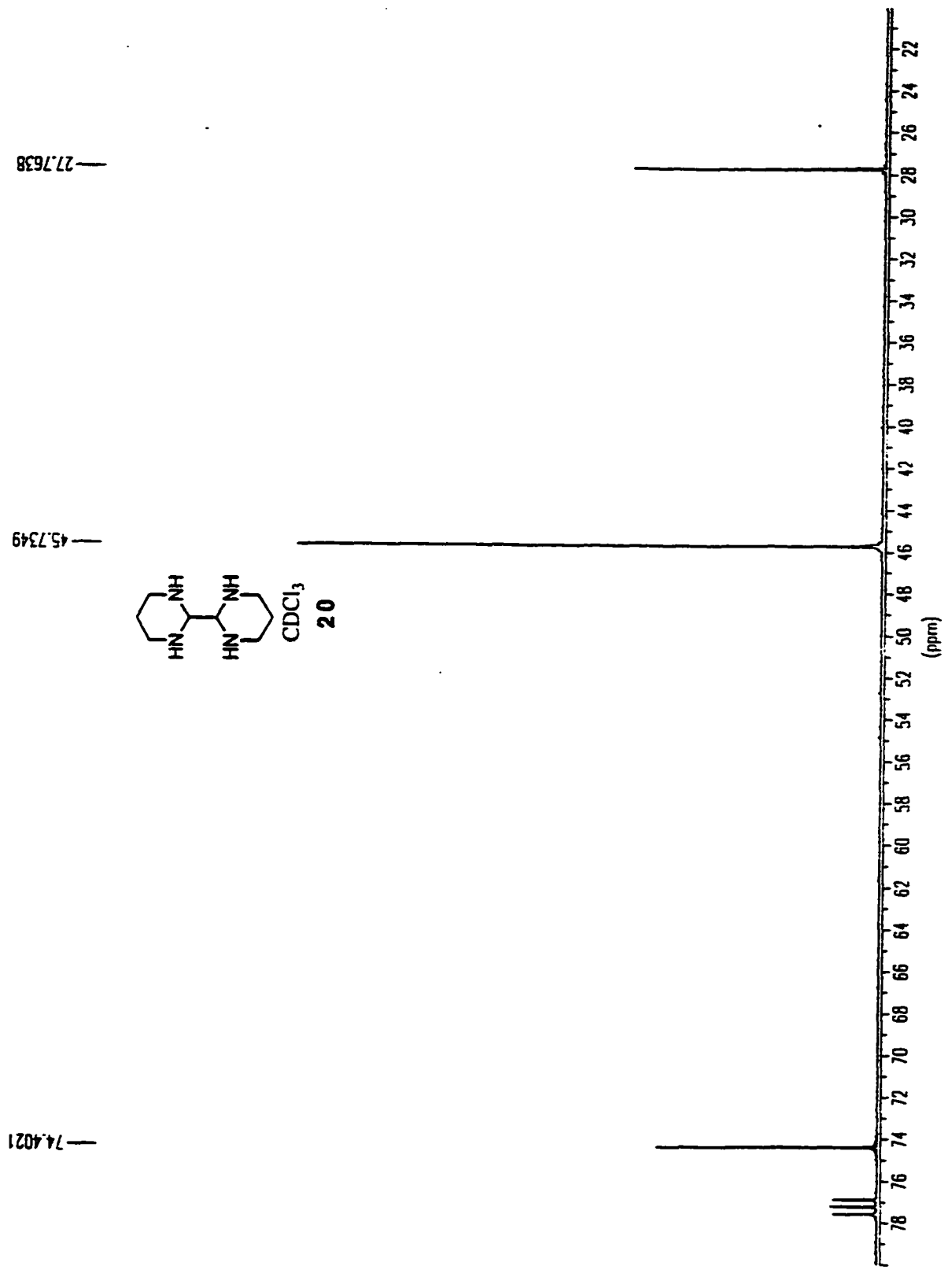

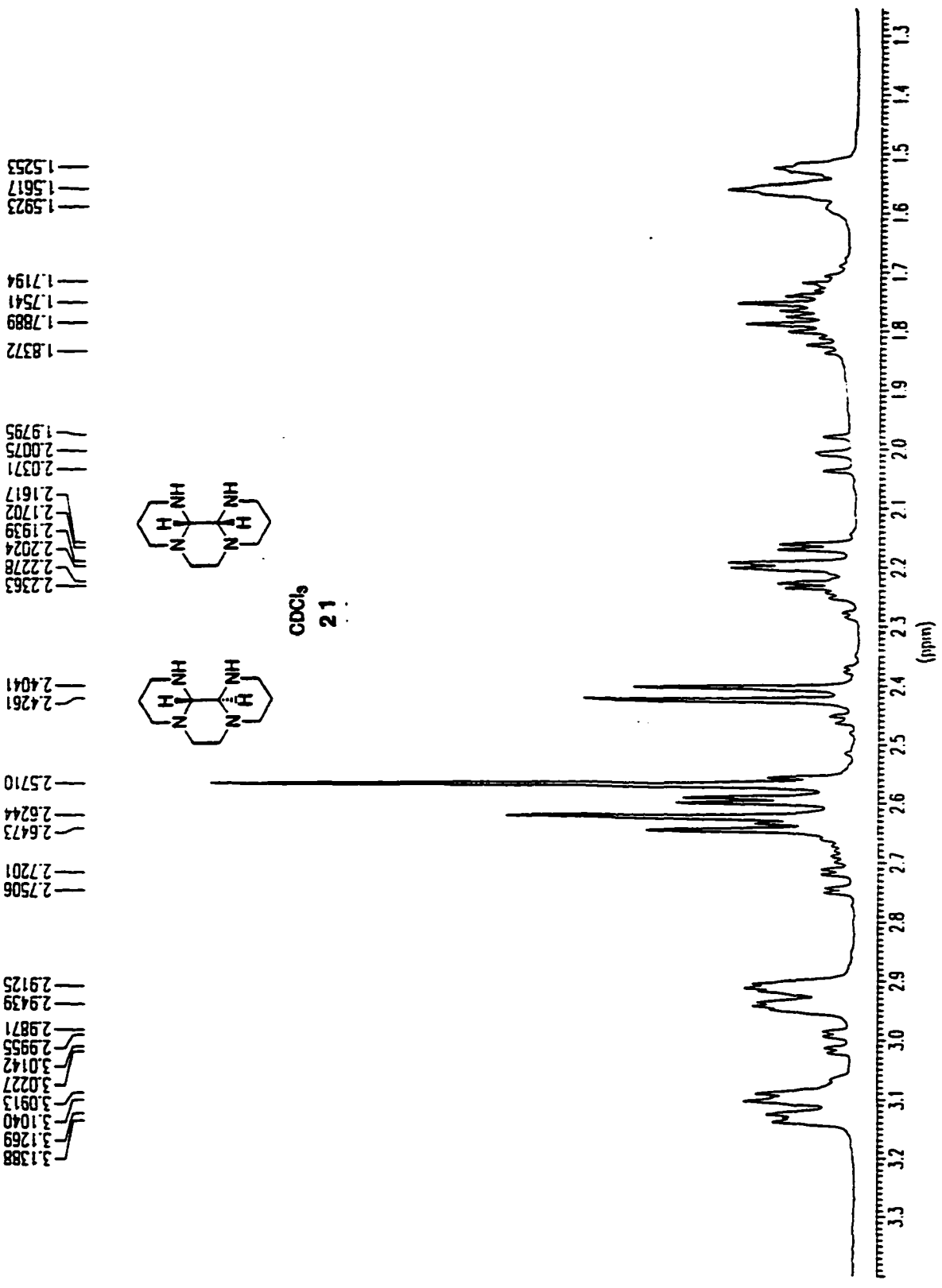

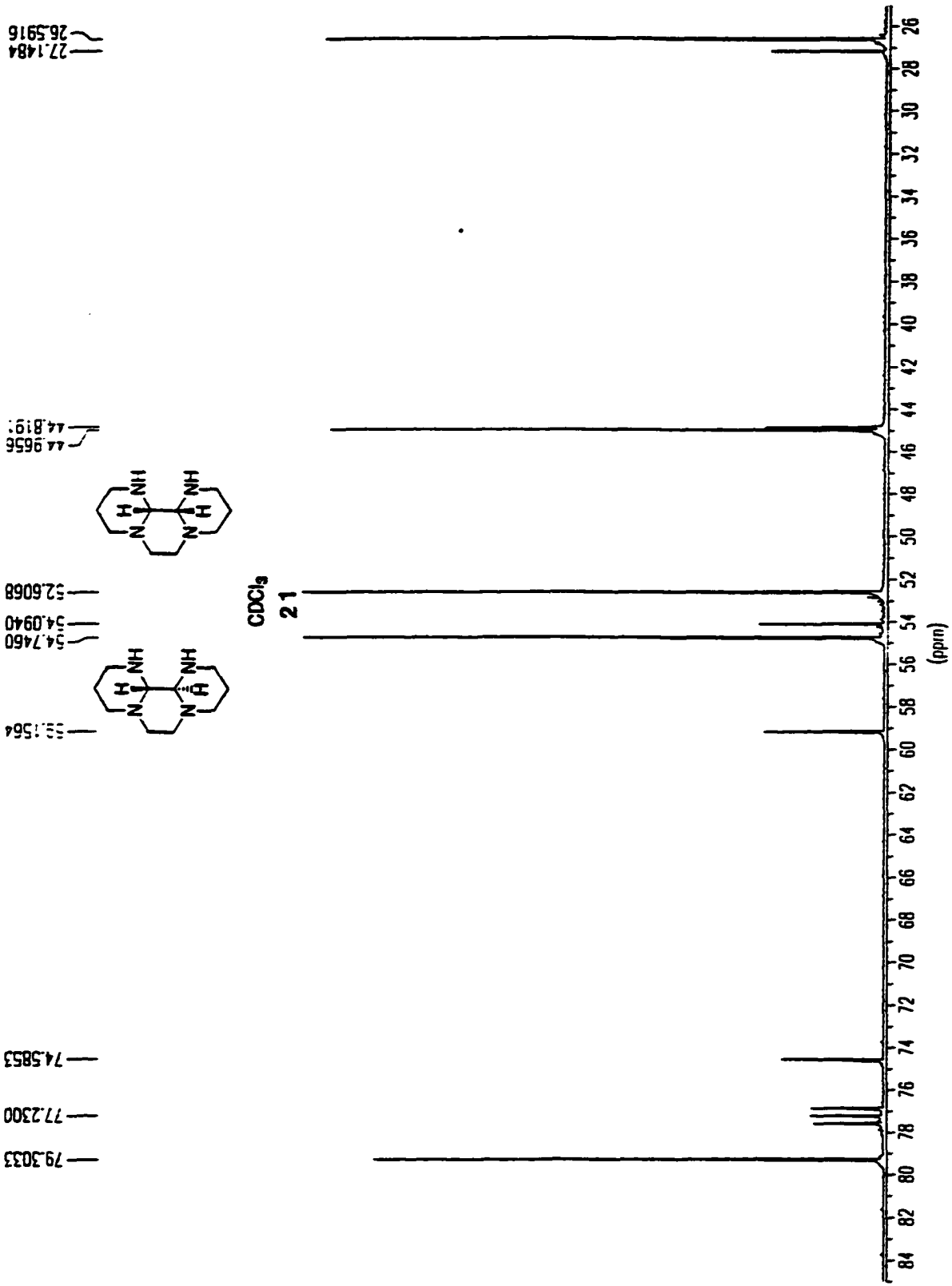

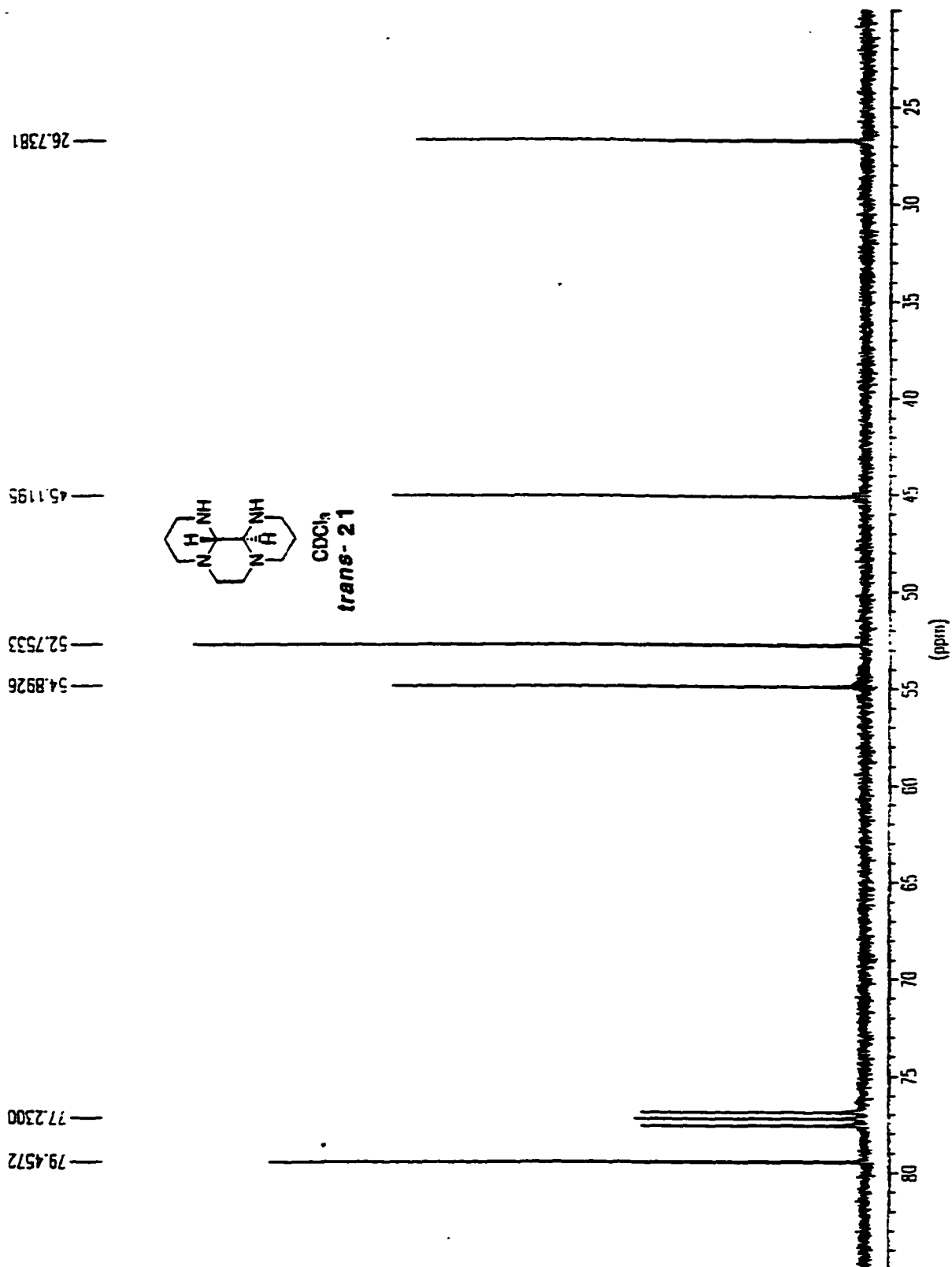

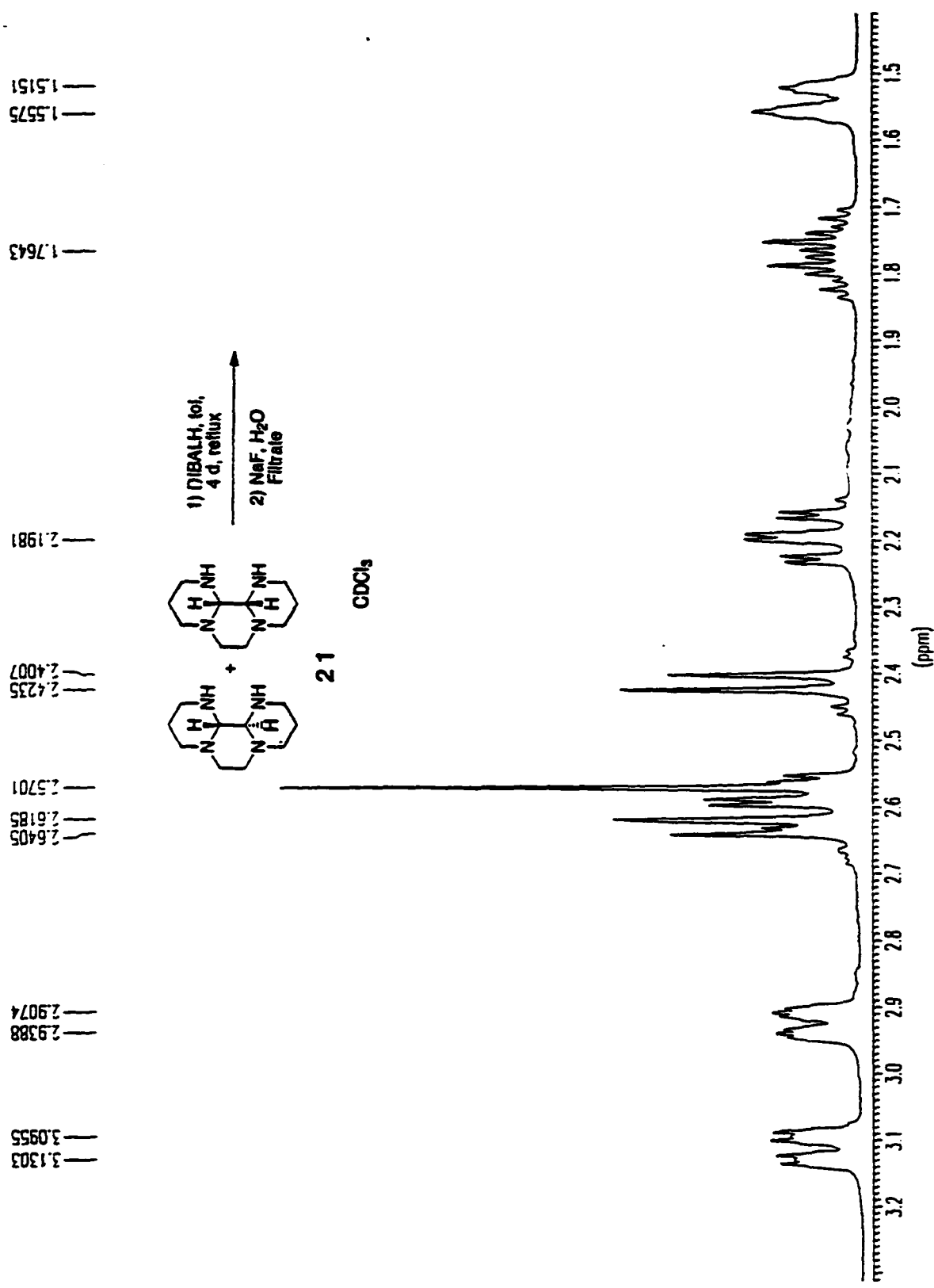

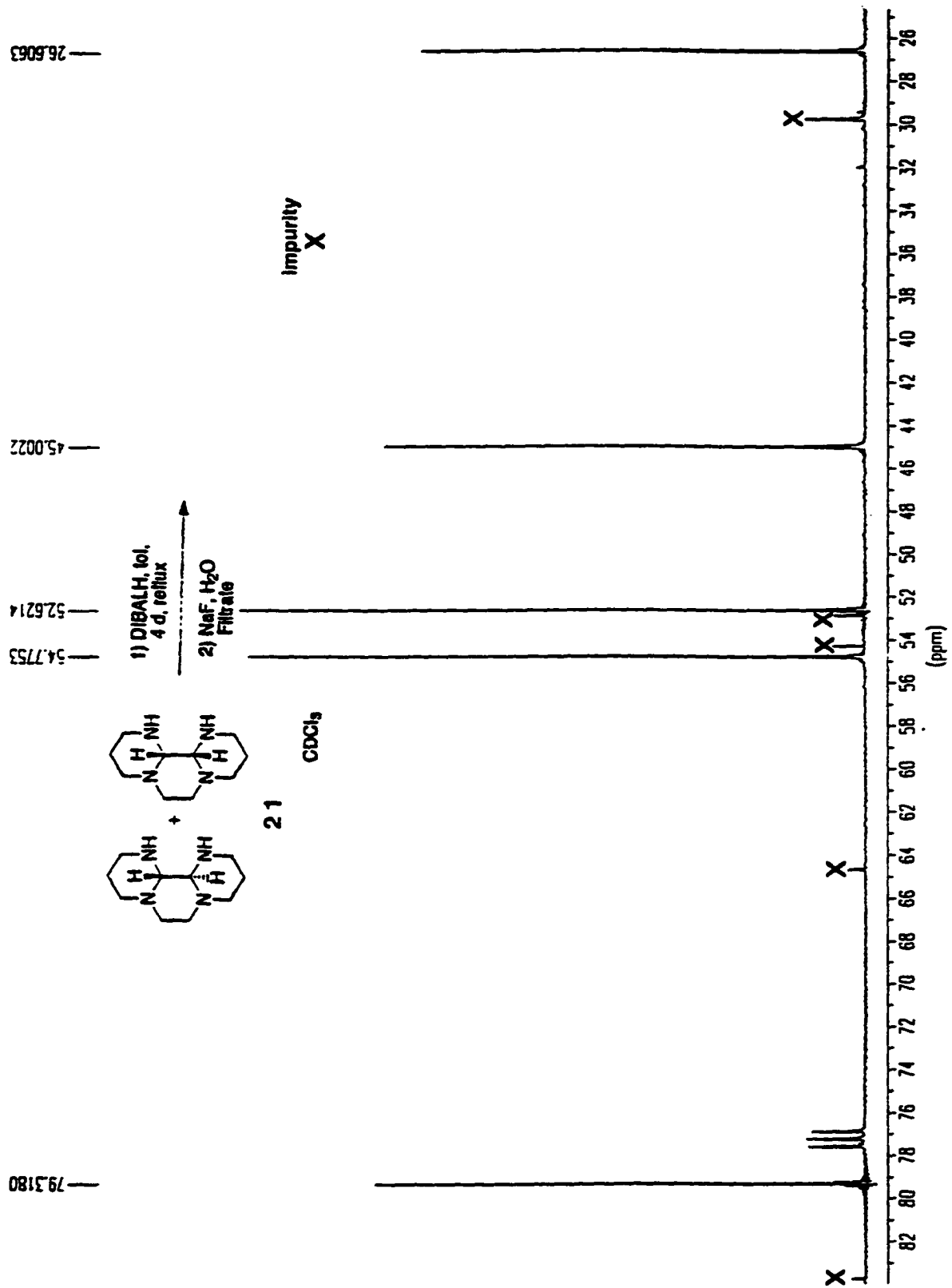

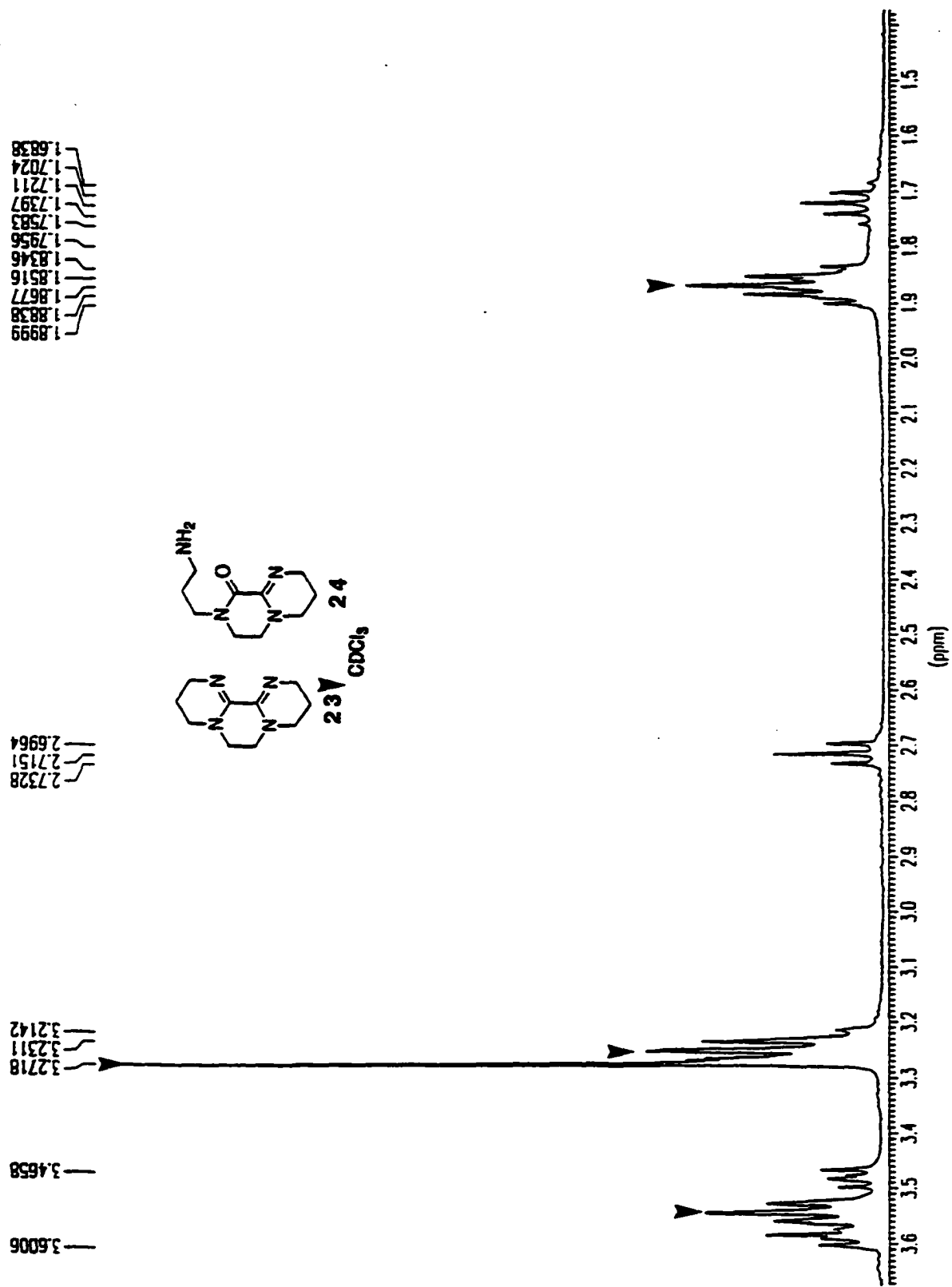

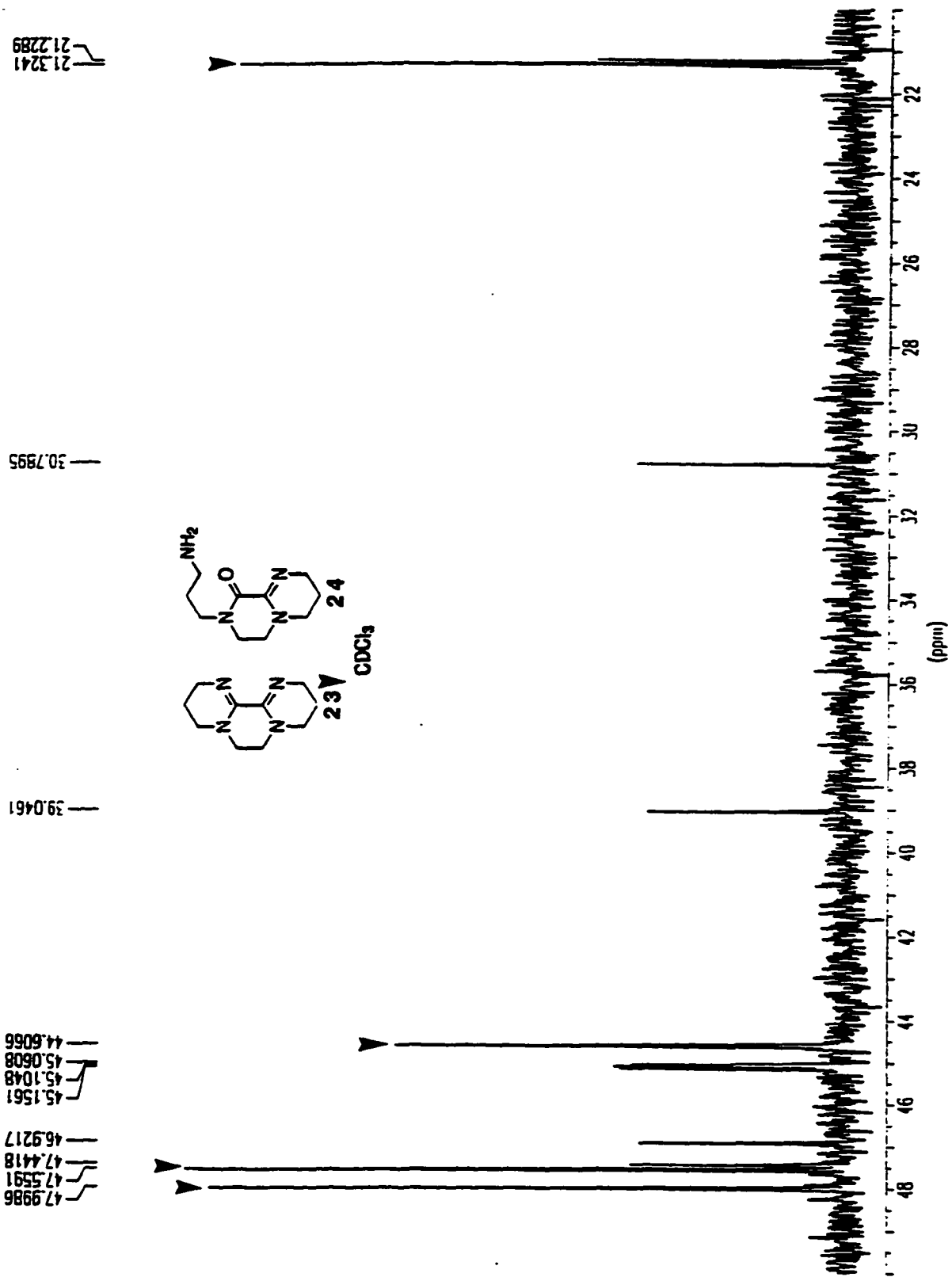

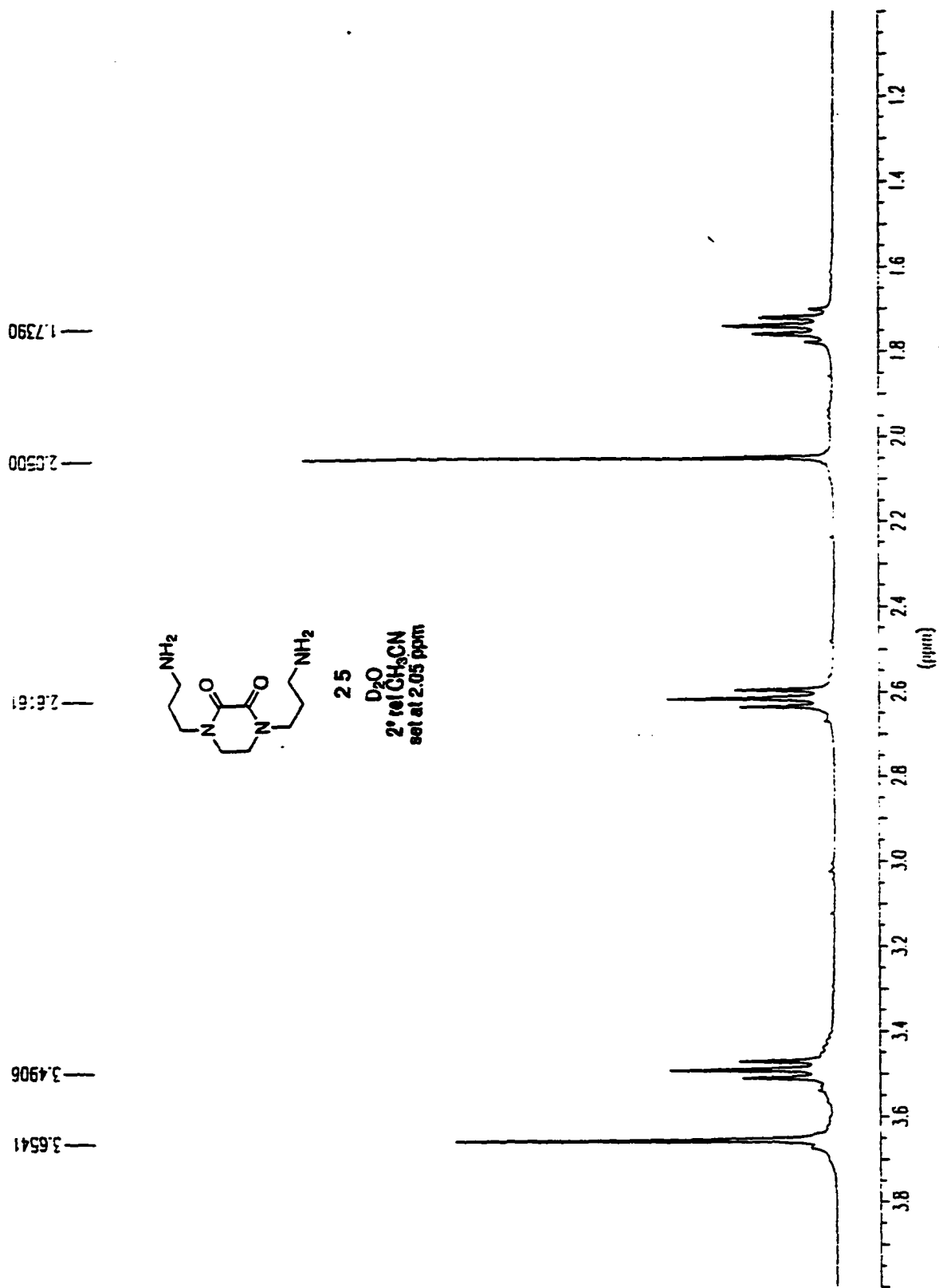

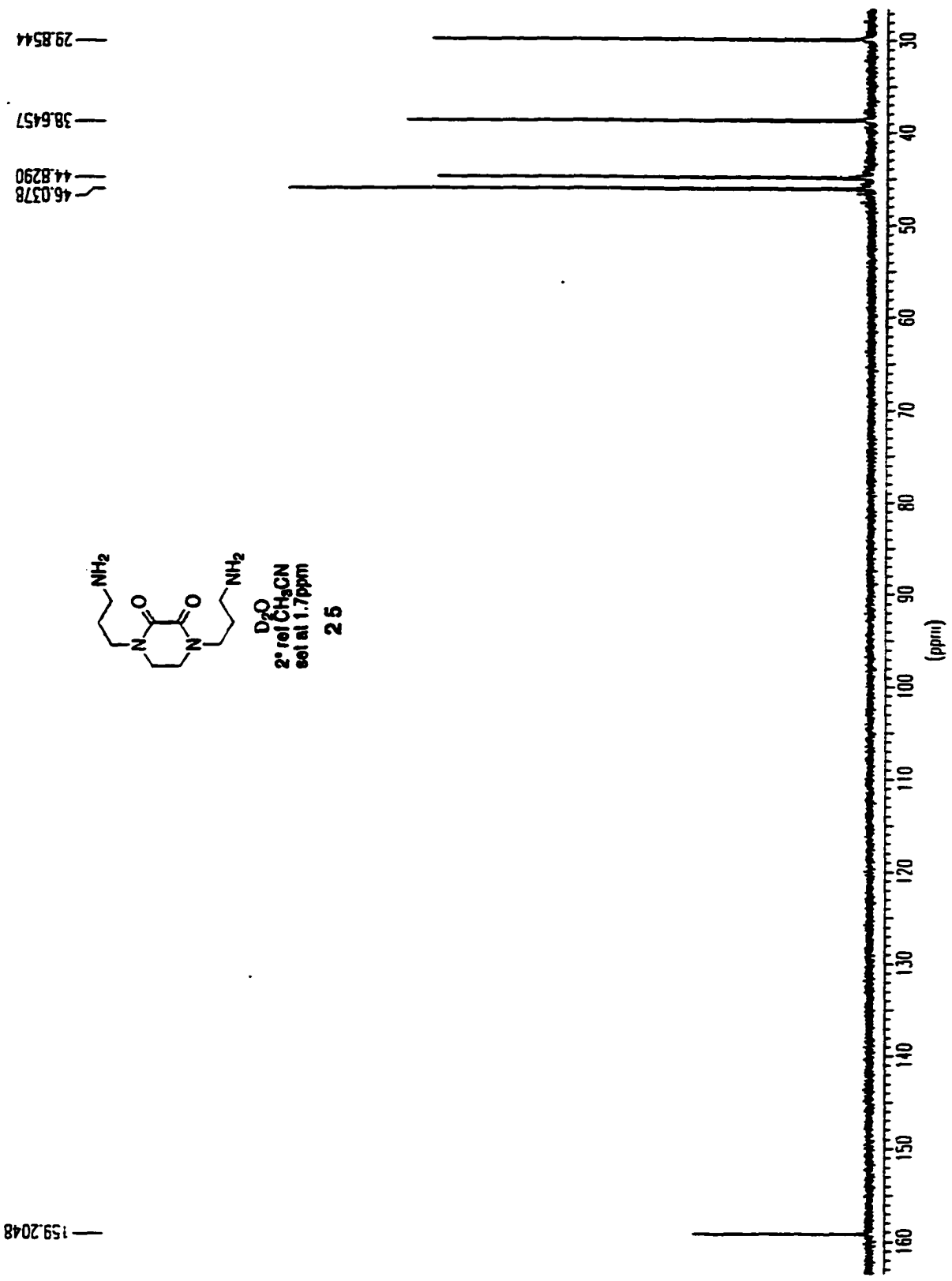

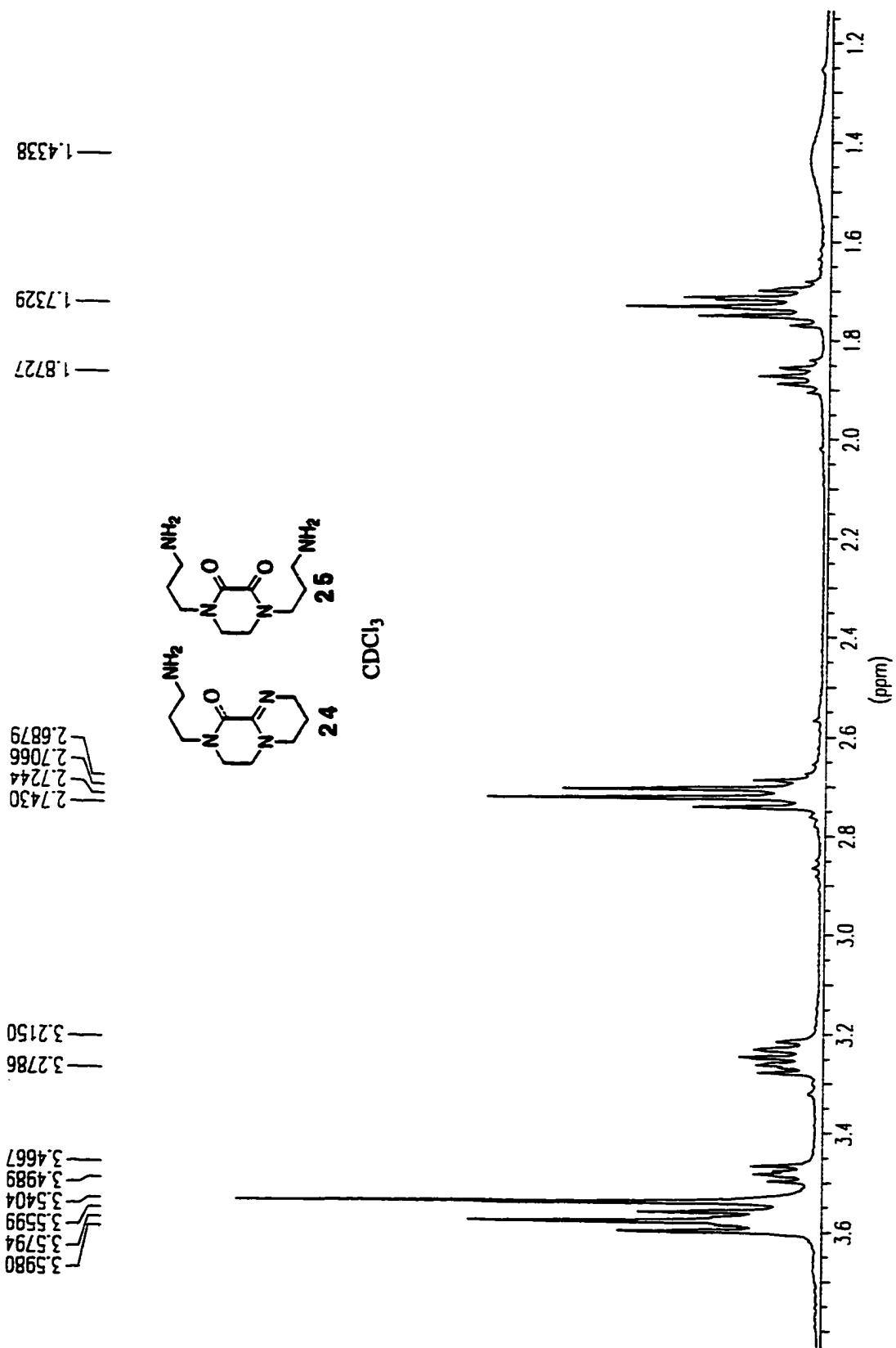

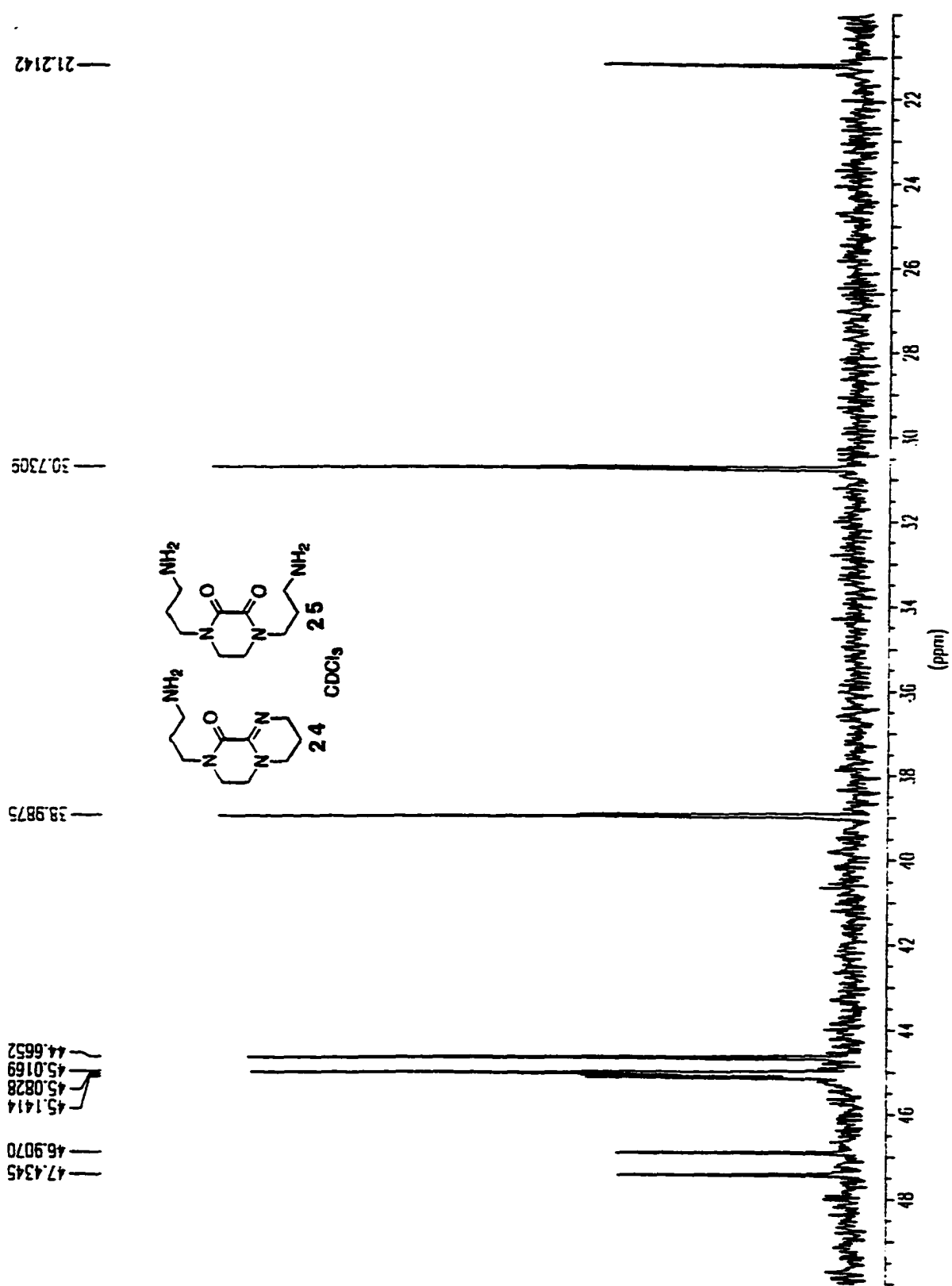

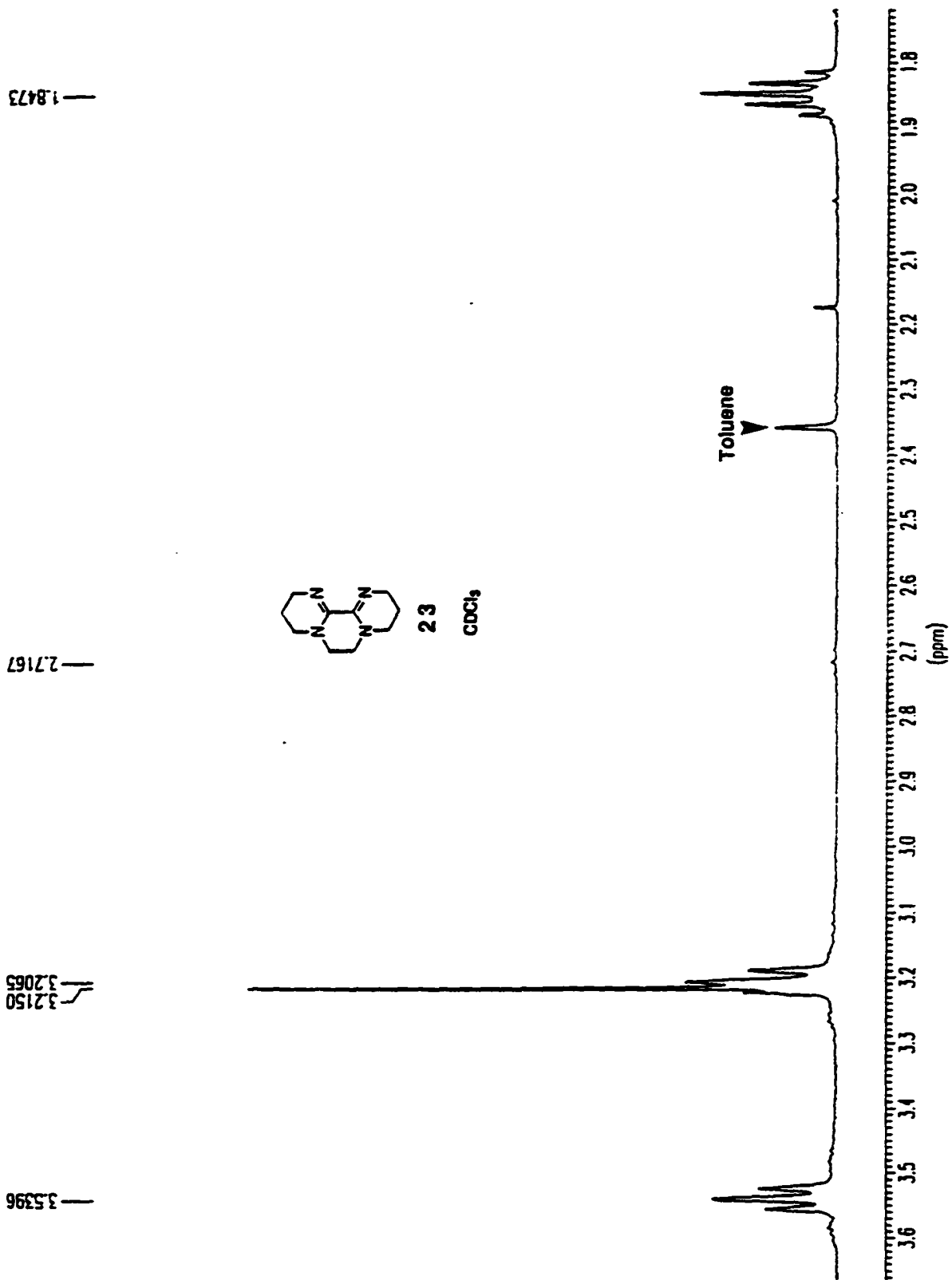

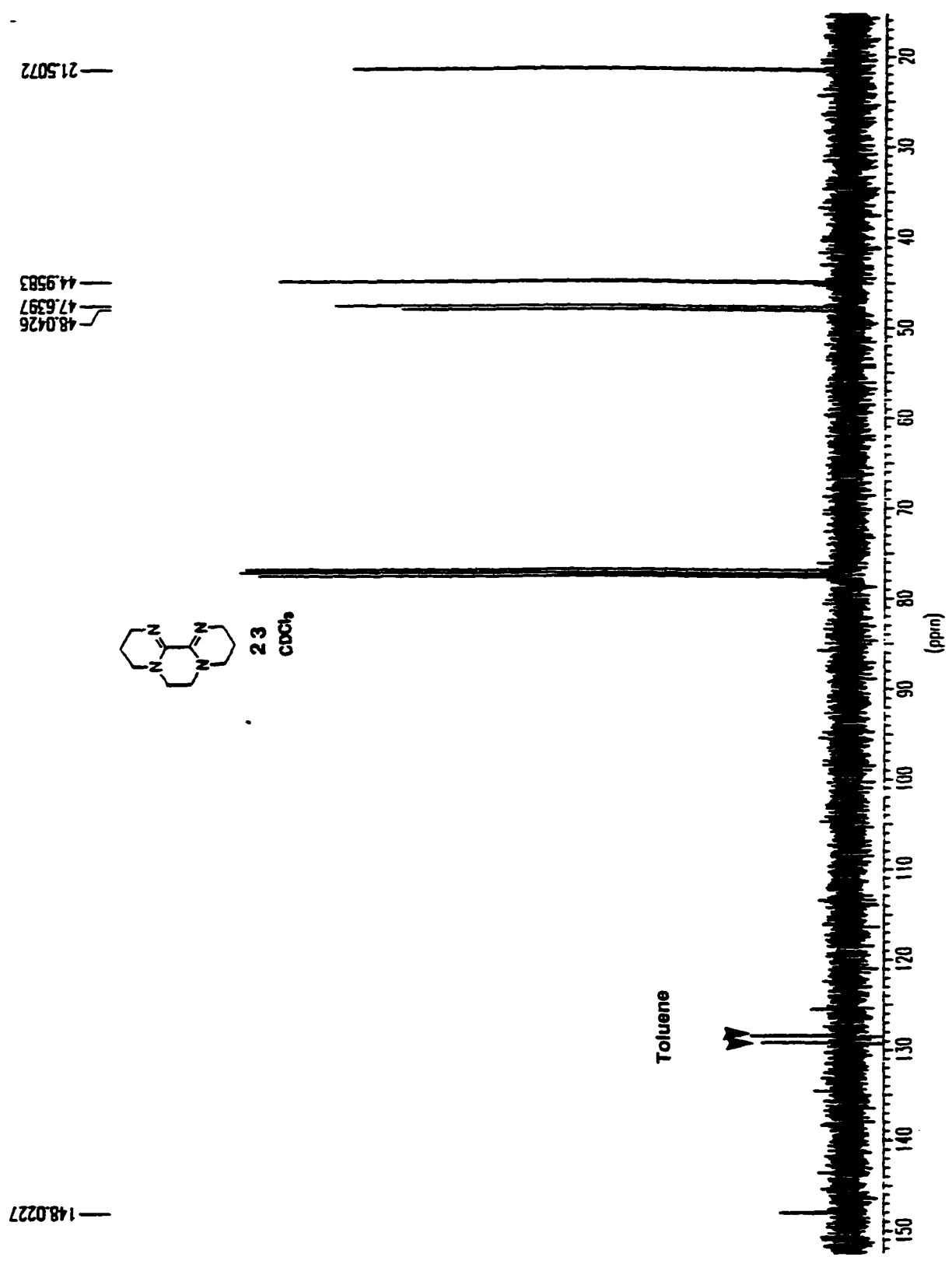

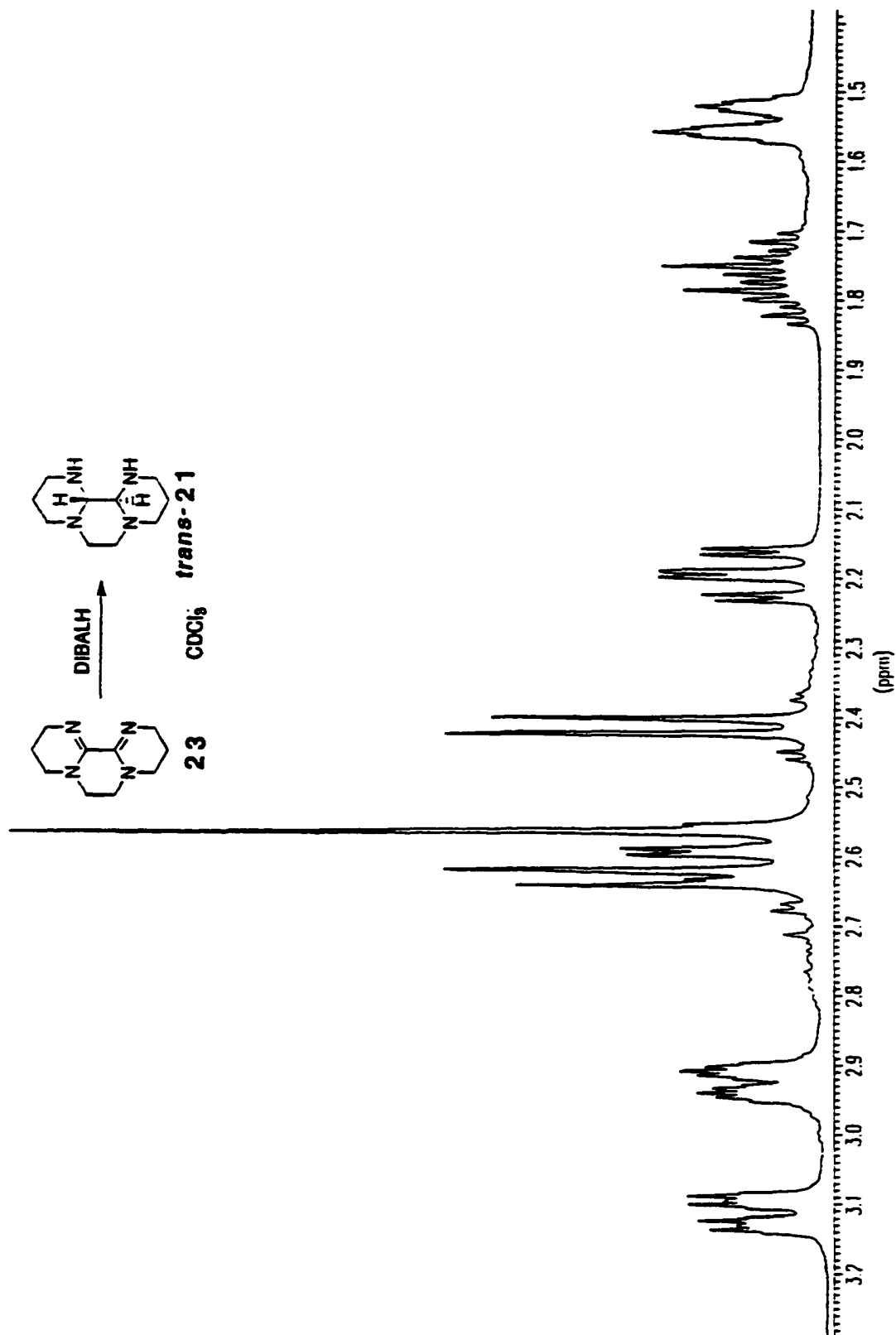

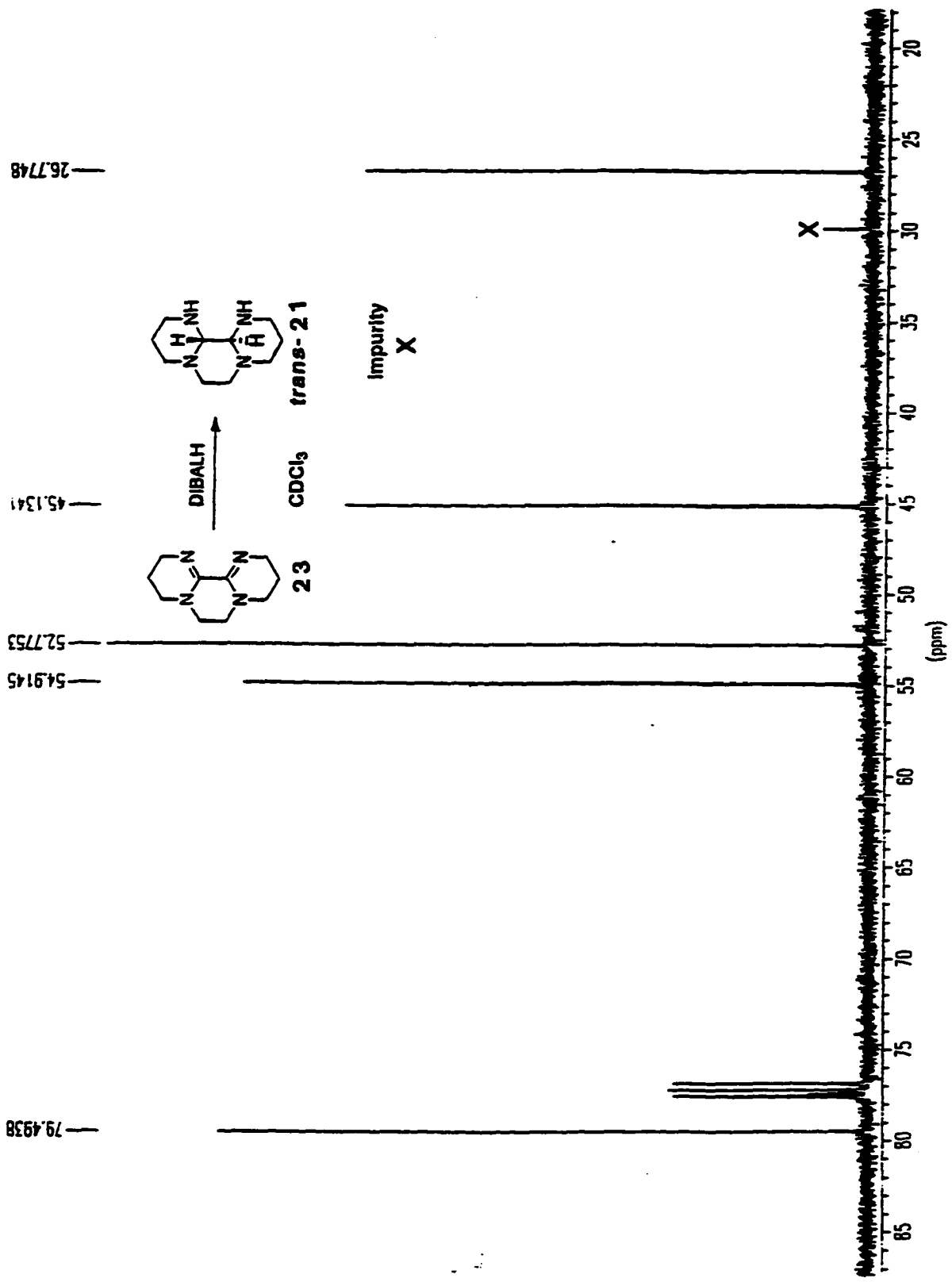

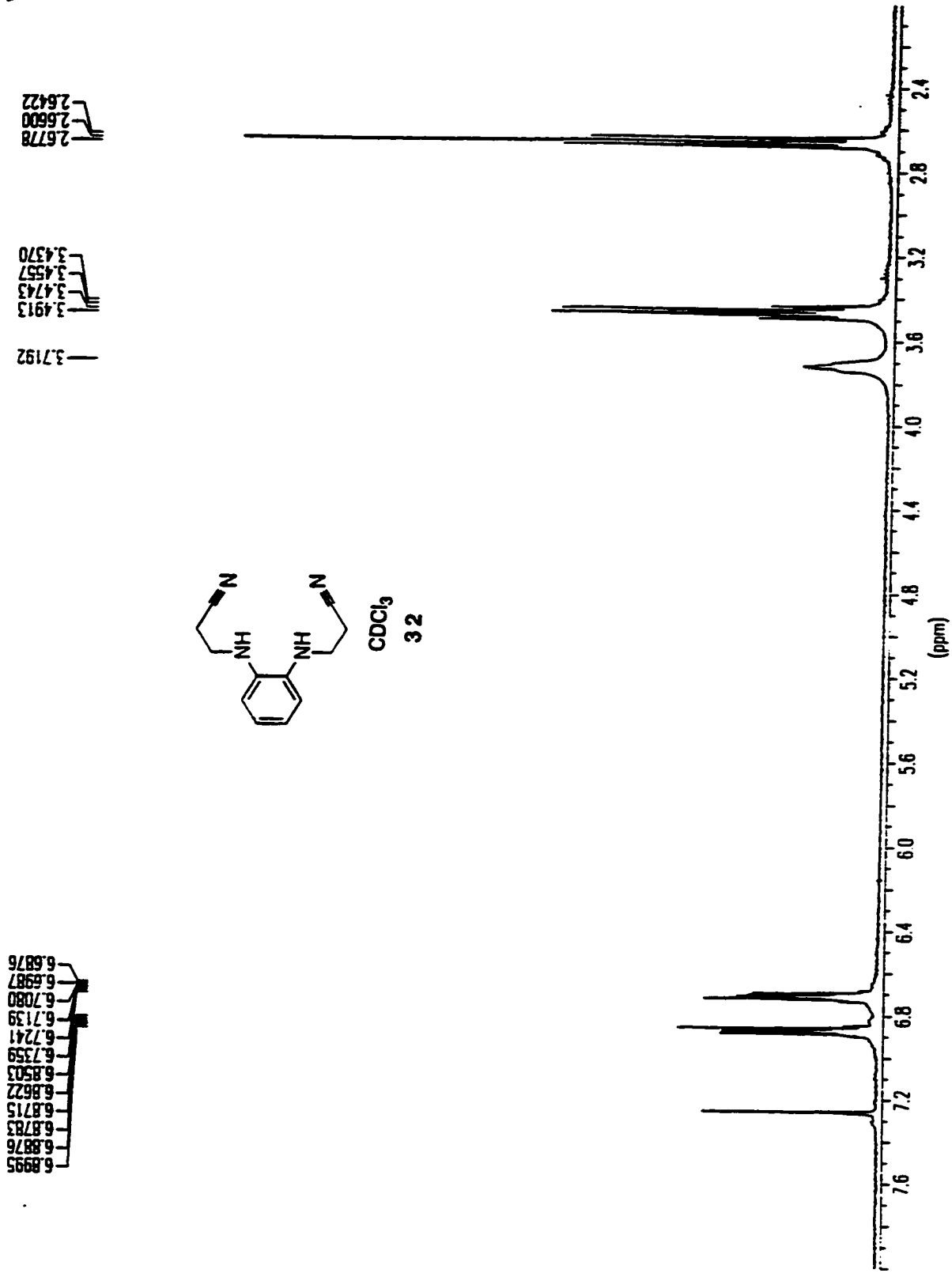

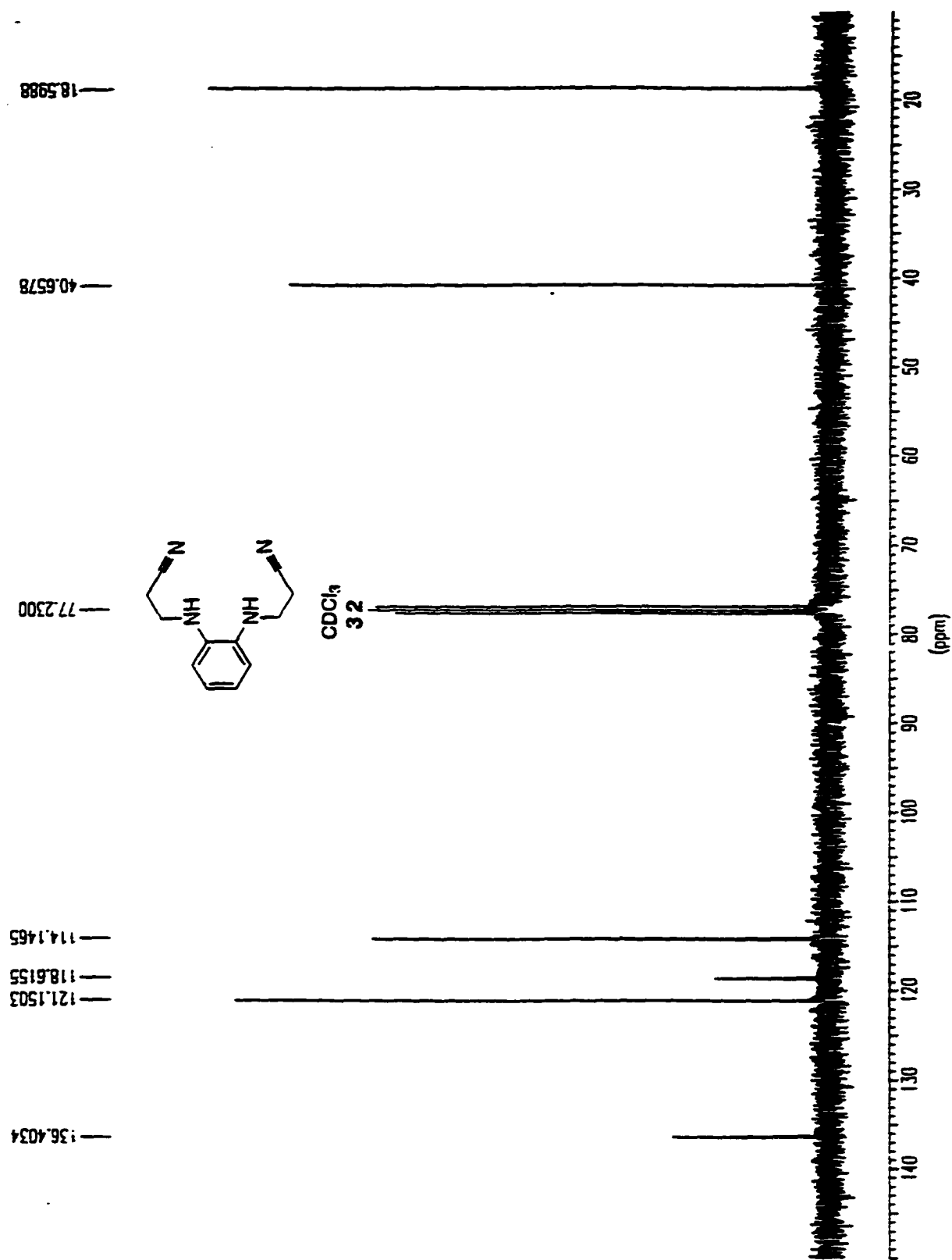

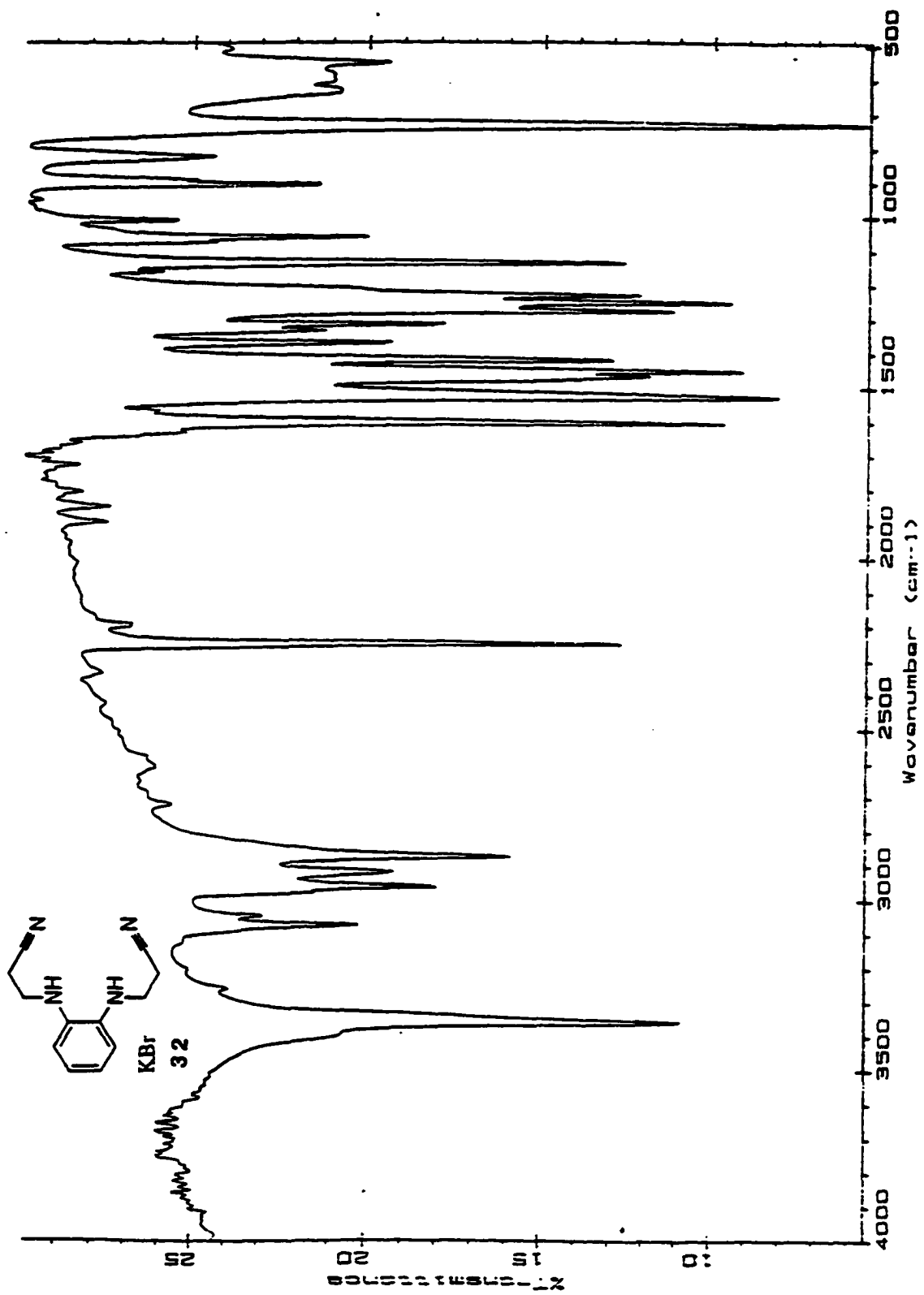

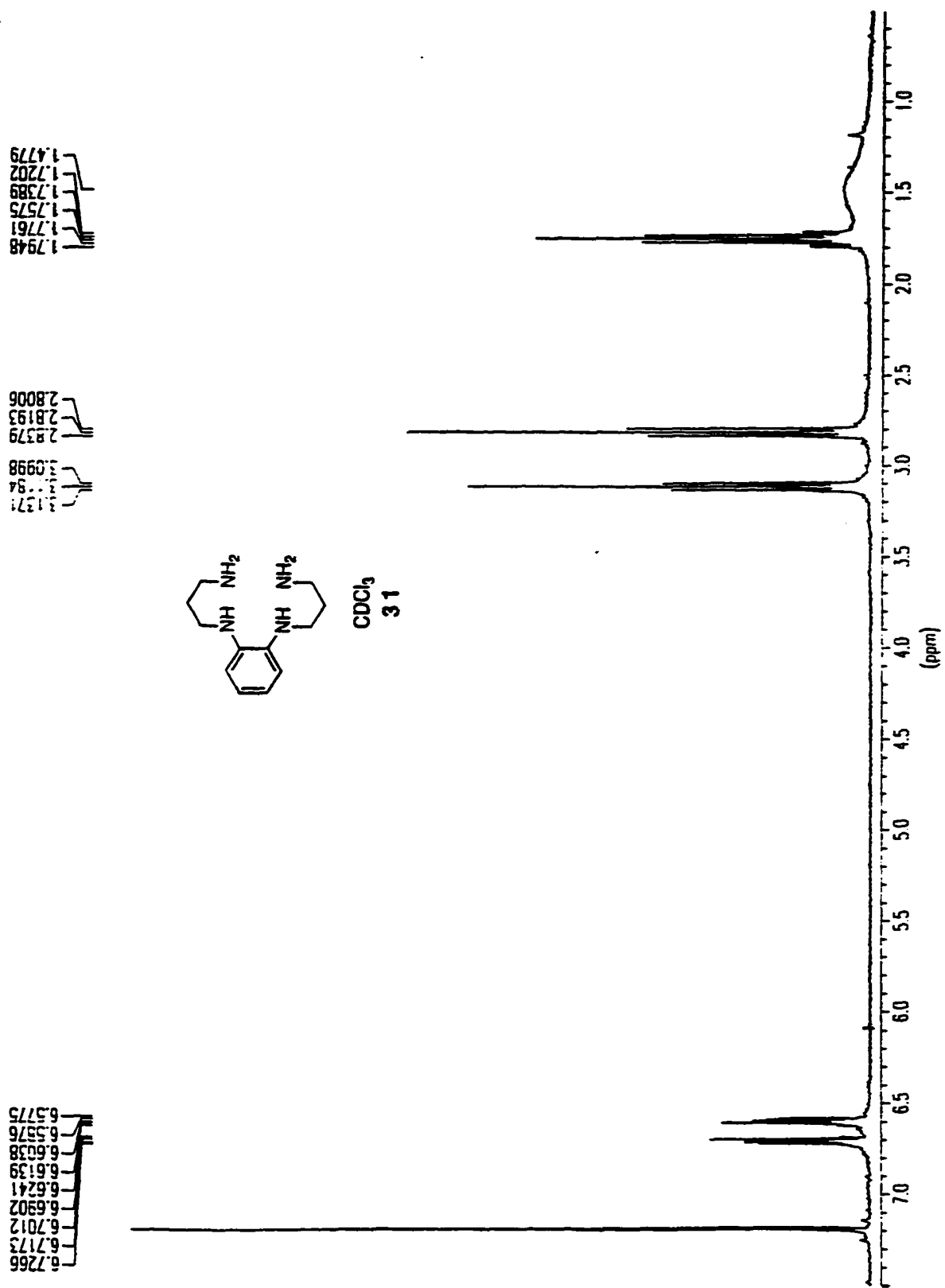

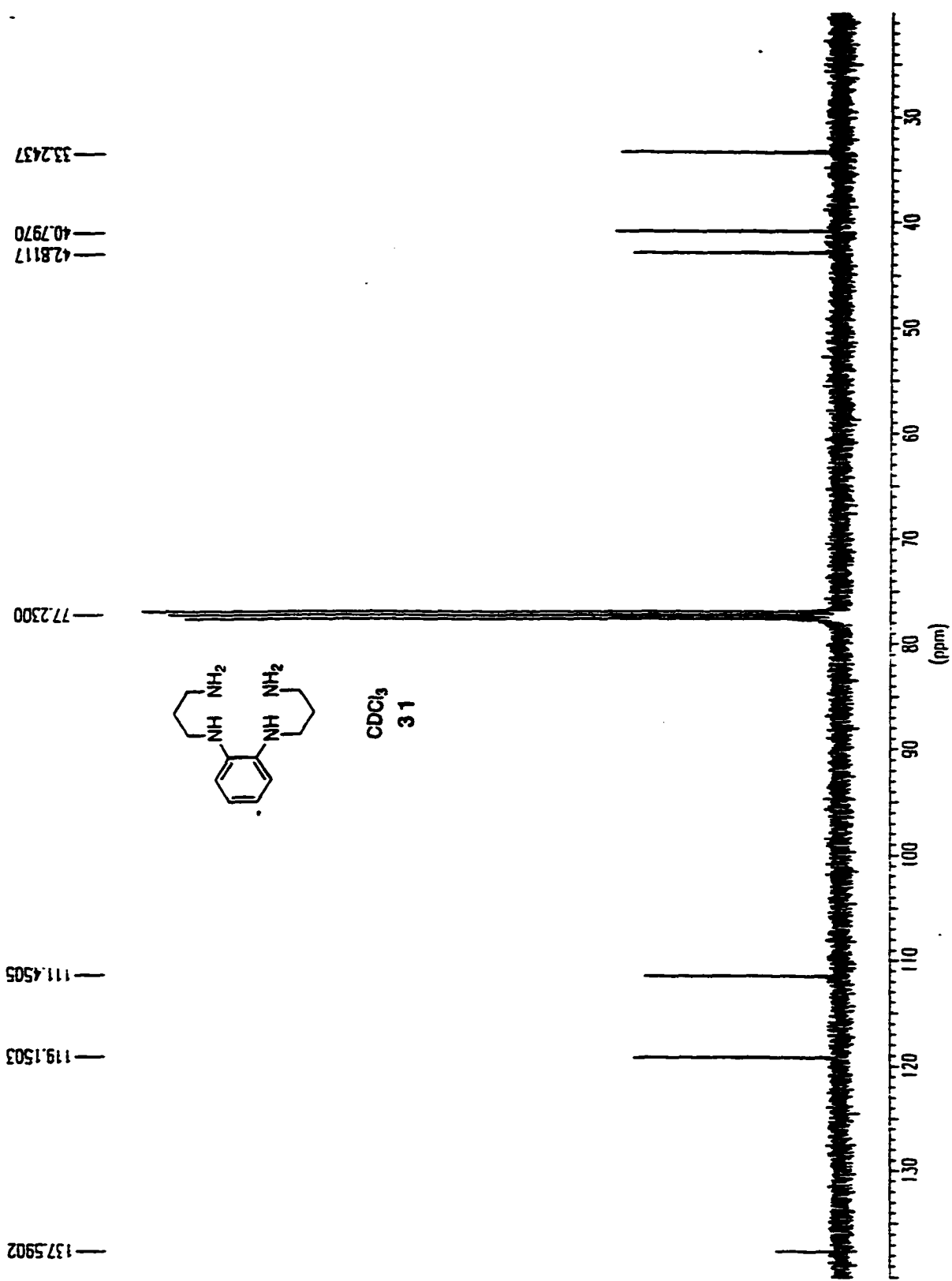

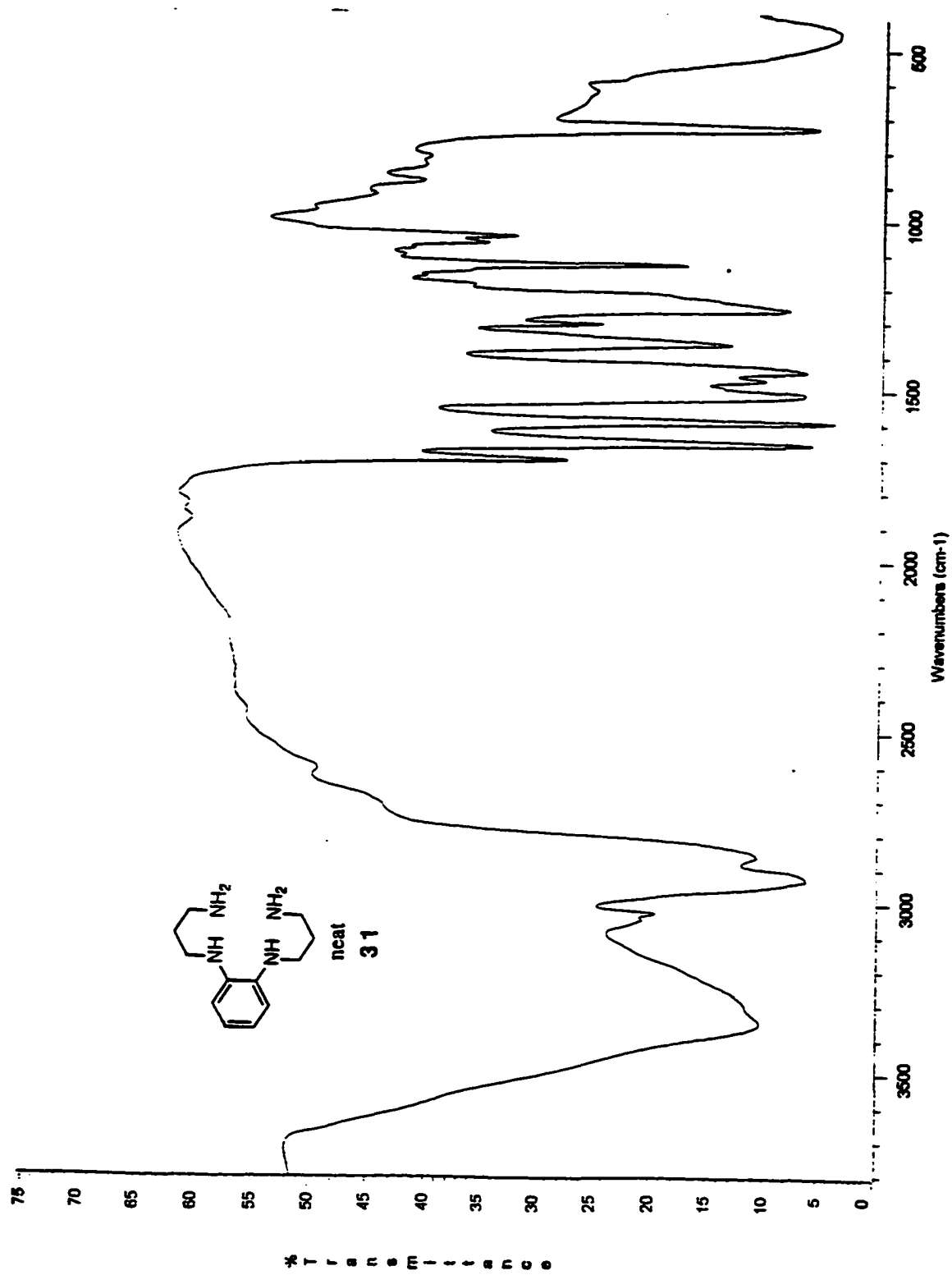

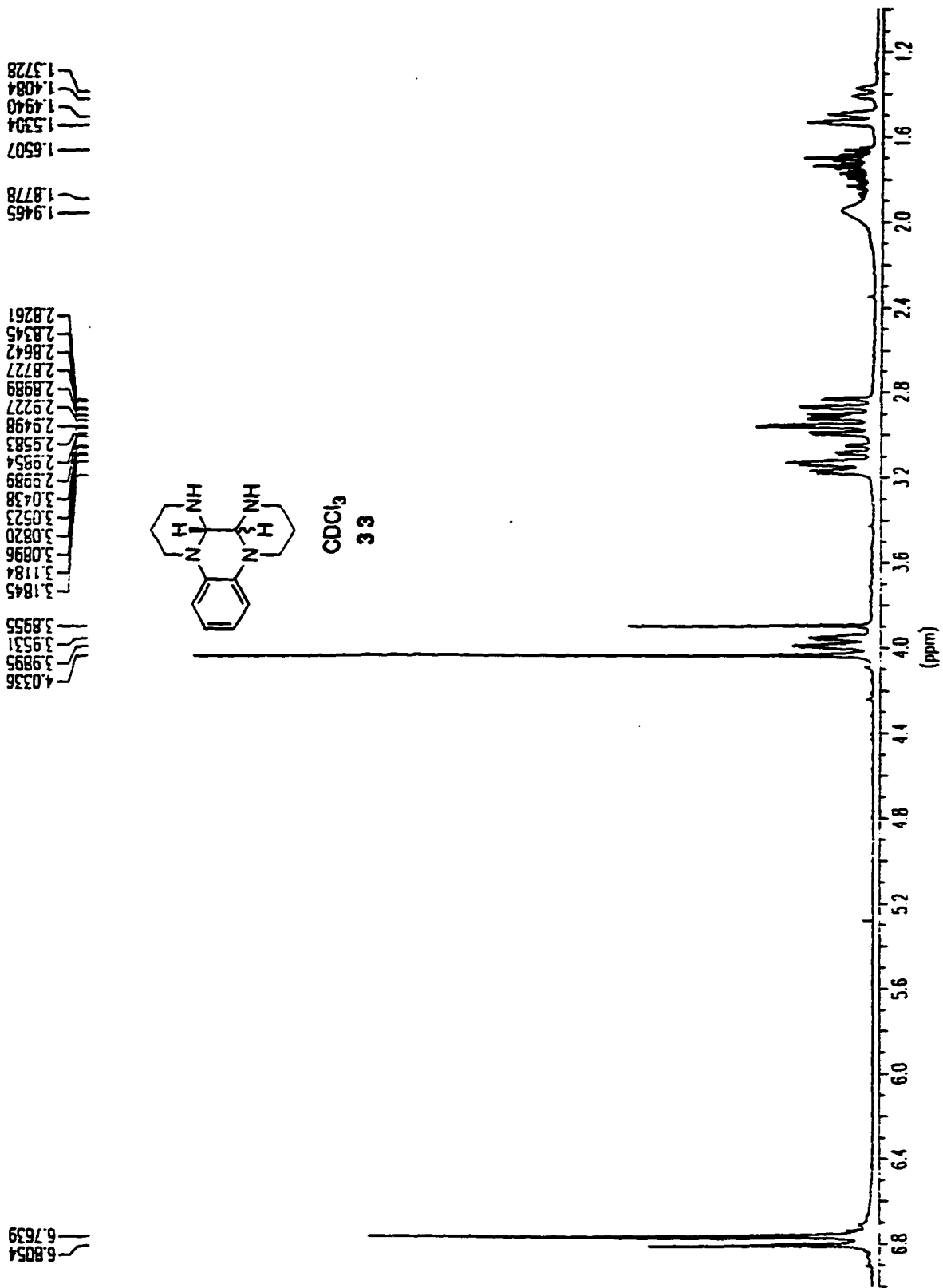

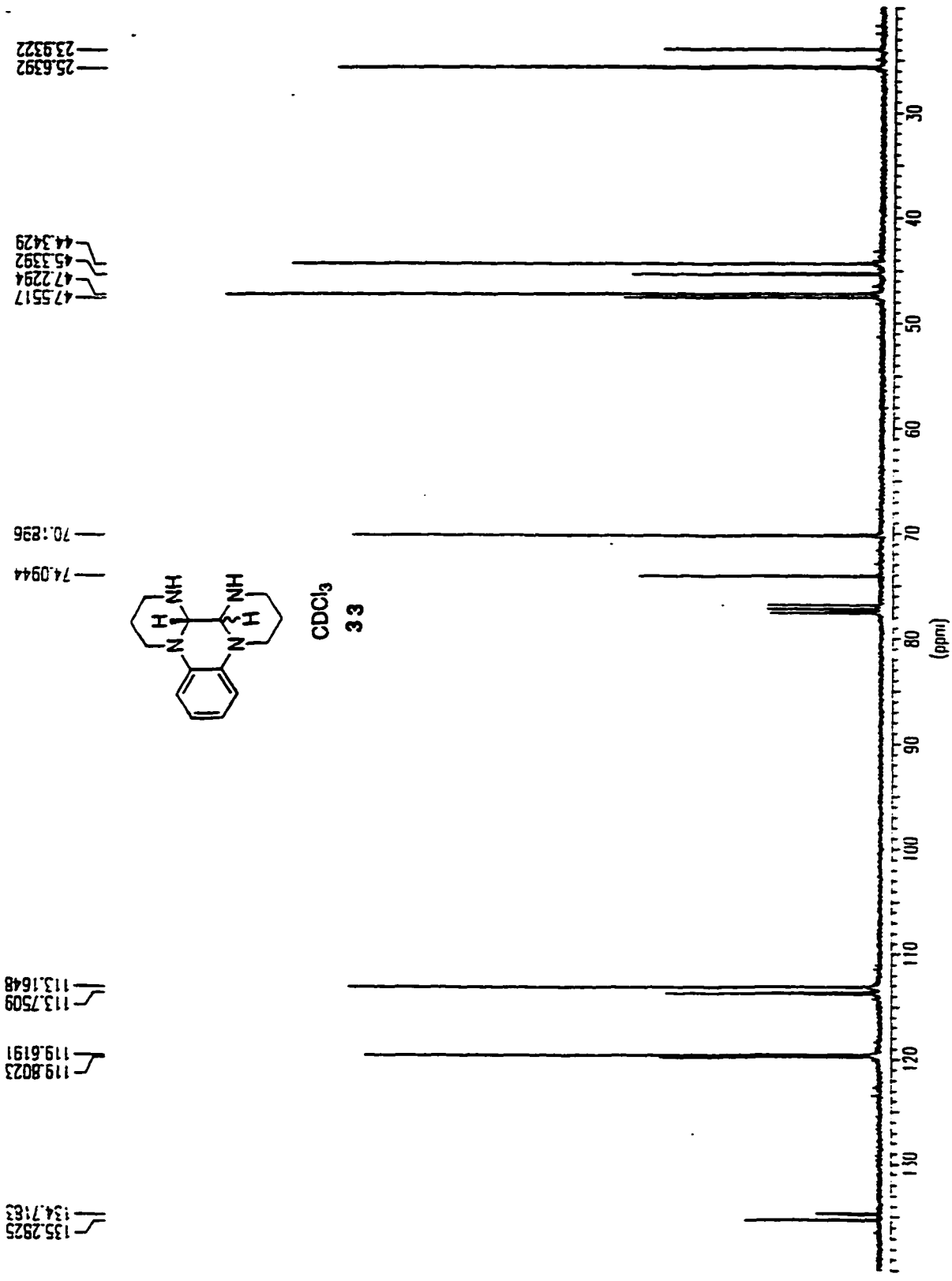

1.9024
1.8846
1.6567
1.5372
1.4940
1.4143
1.3770

3.1710
3.1345
3.0904
3.0532
2.9989
2.9557
2.9201
2.9023
2.8744
2.8371
2.8286

4.0361
3.9929
3.9523
3.9014

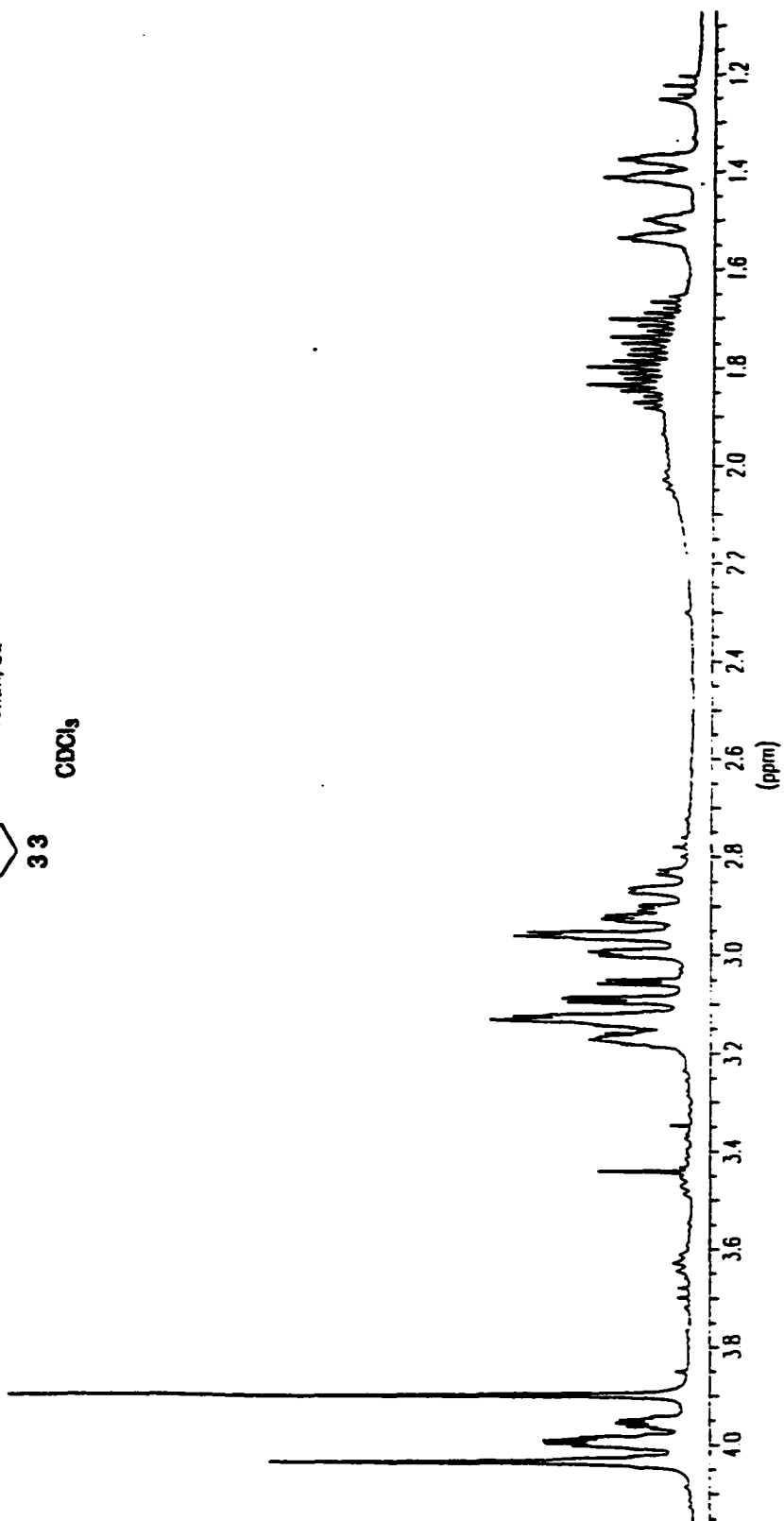
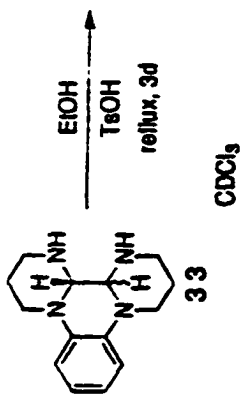

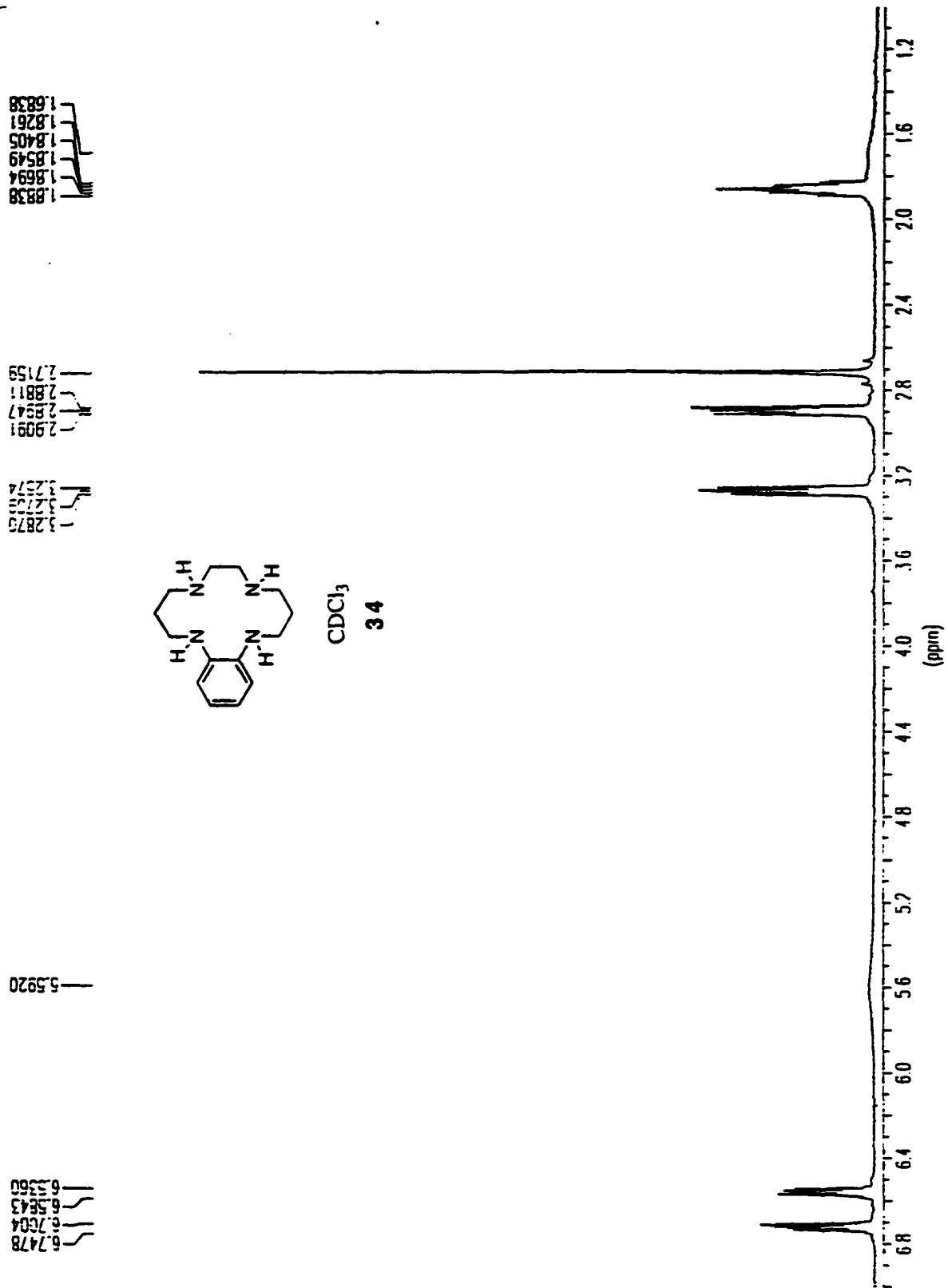

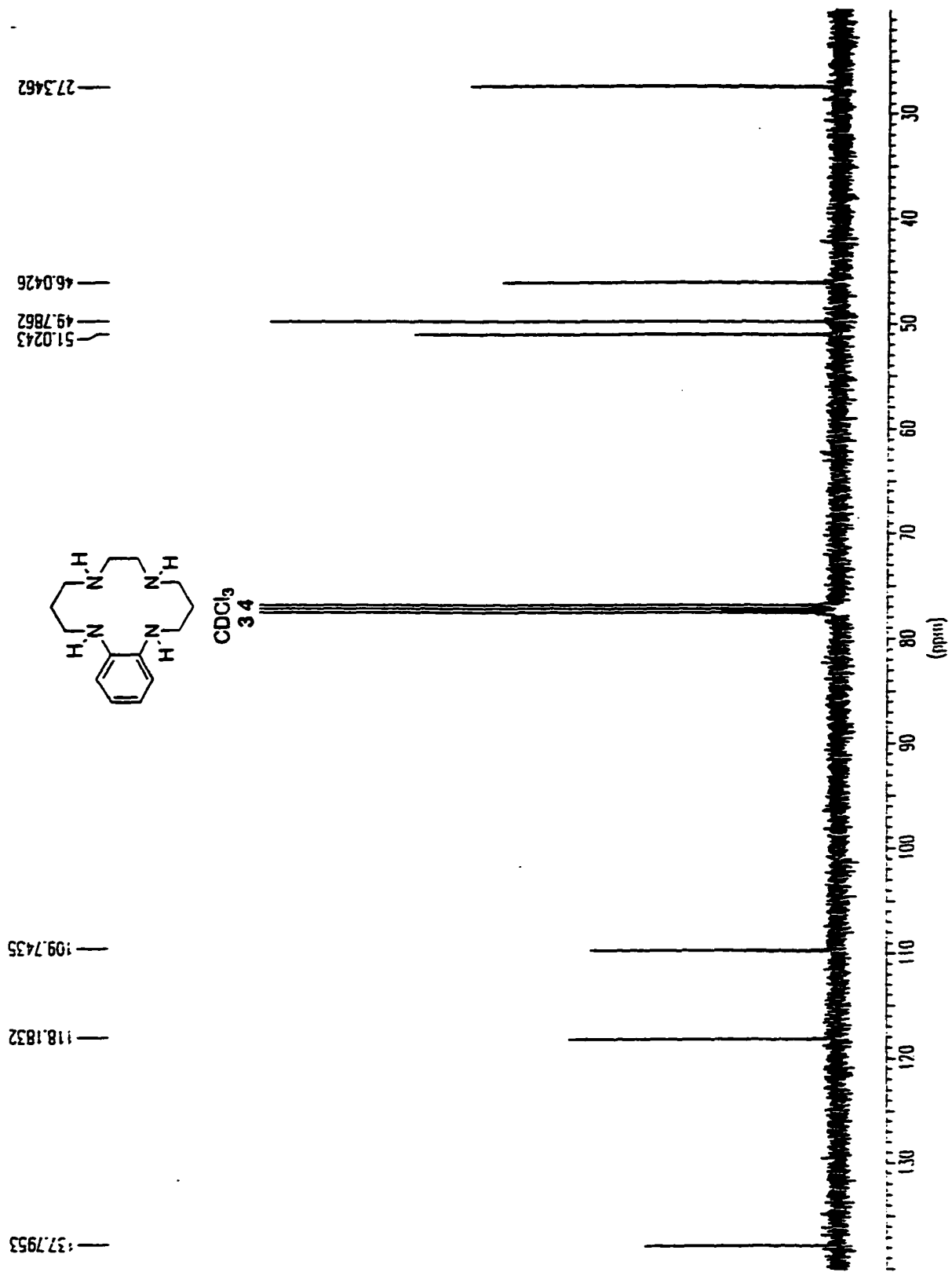

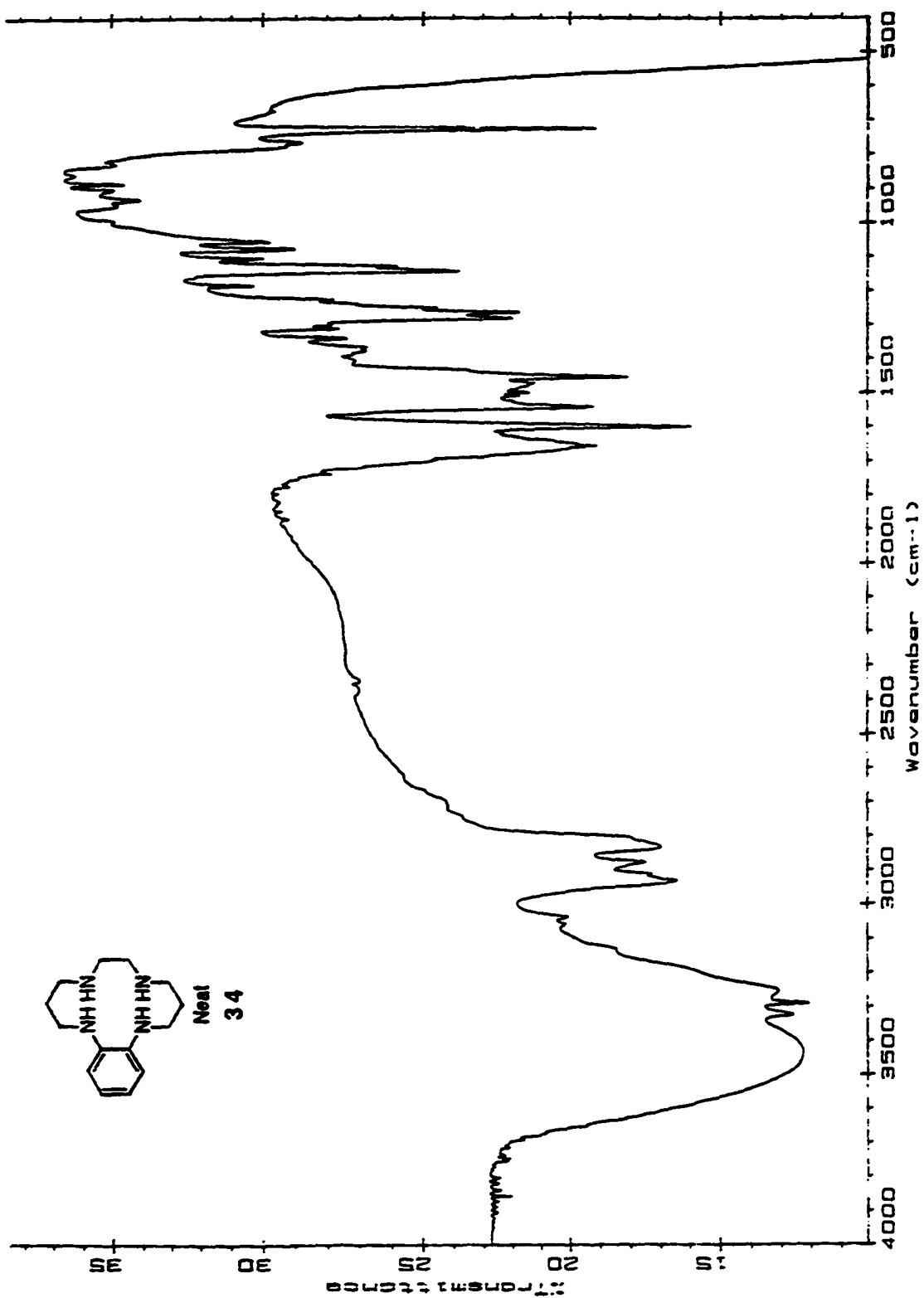

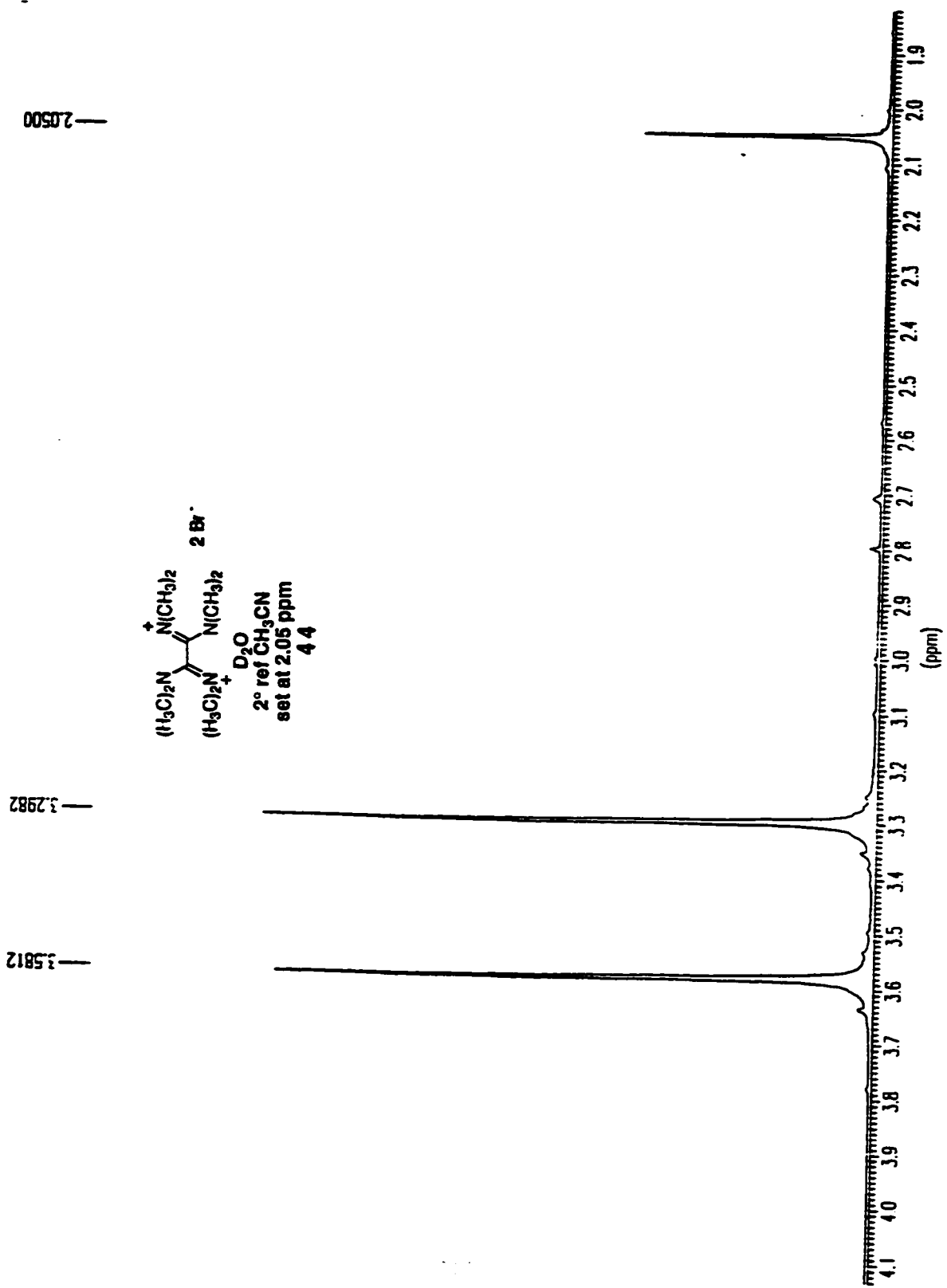

44.0817
43.1513

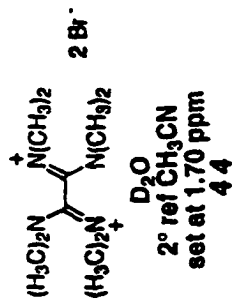

156.6846

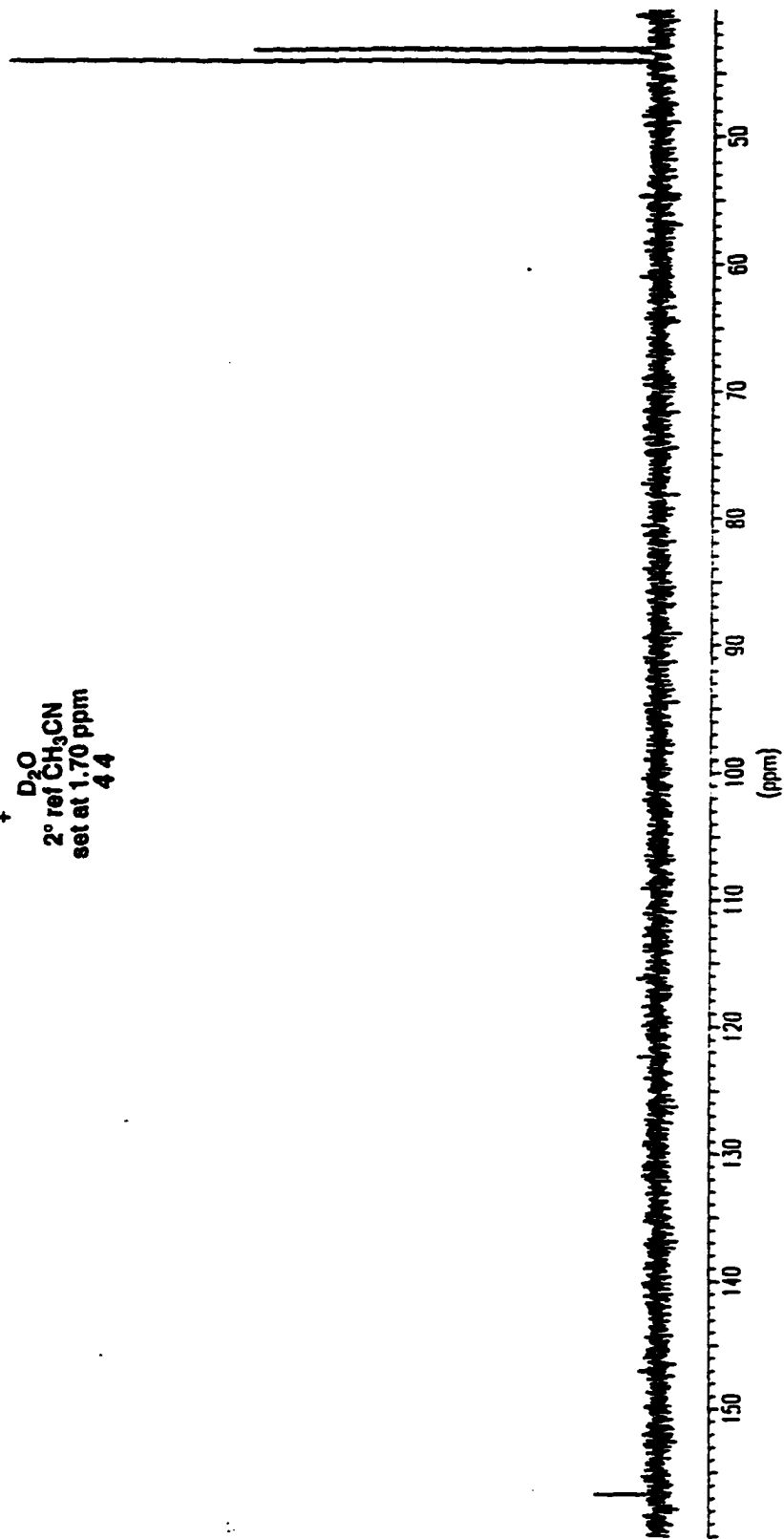

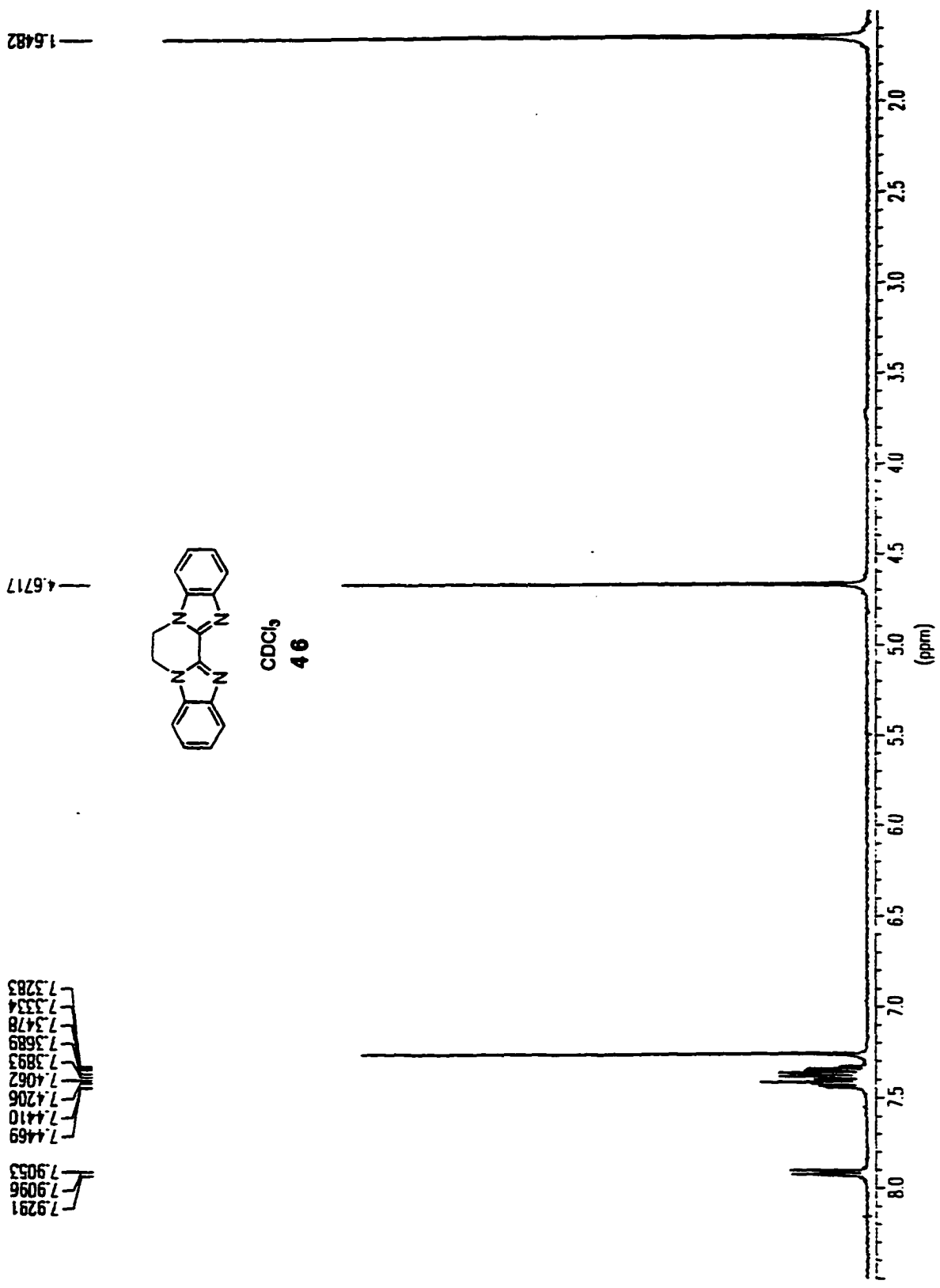

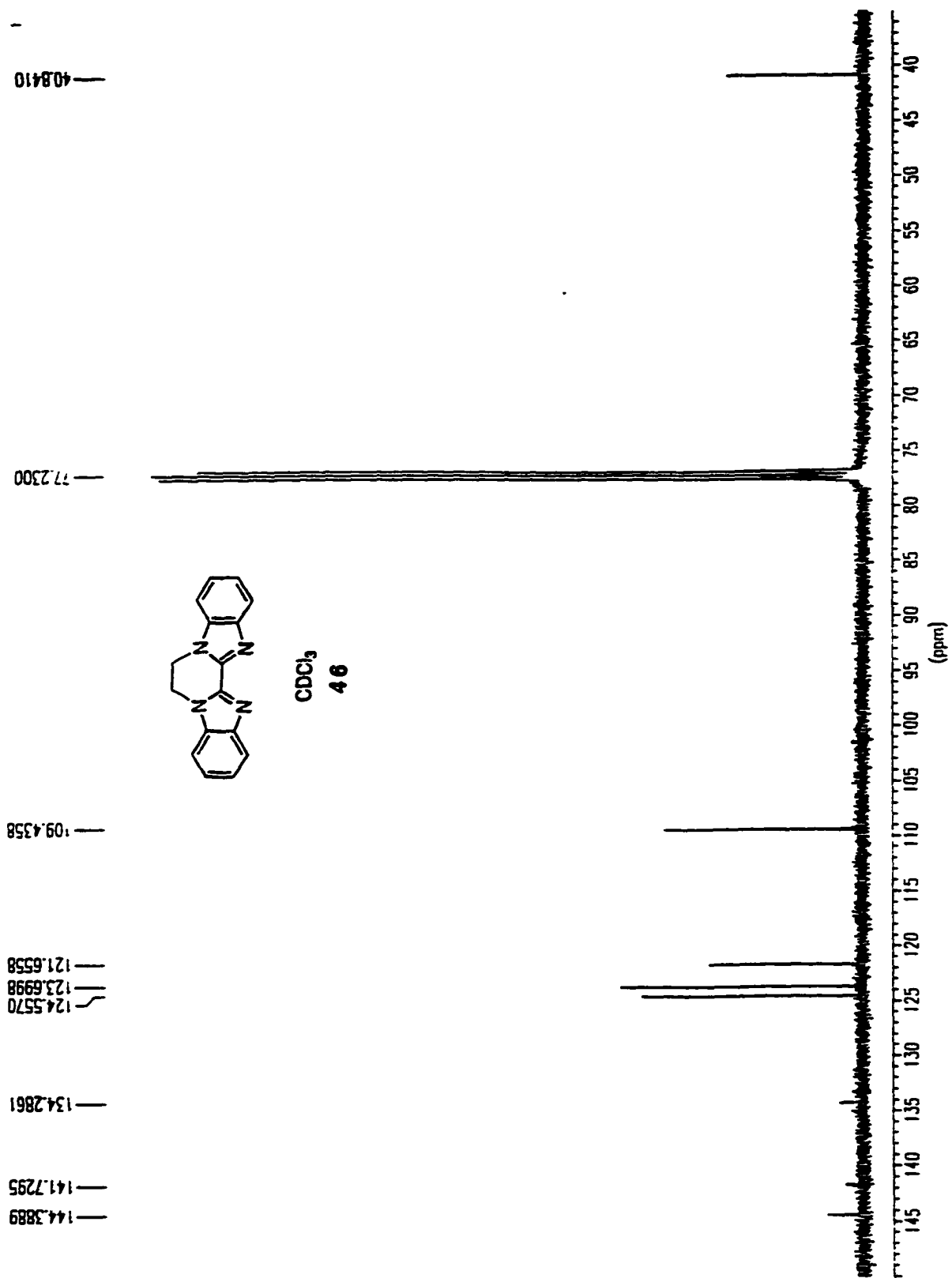

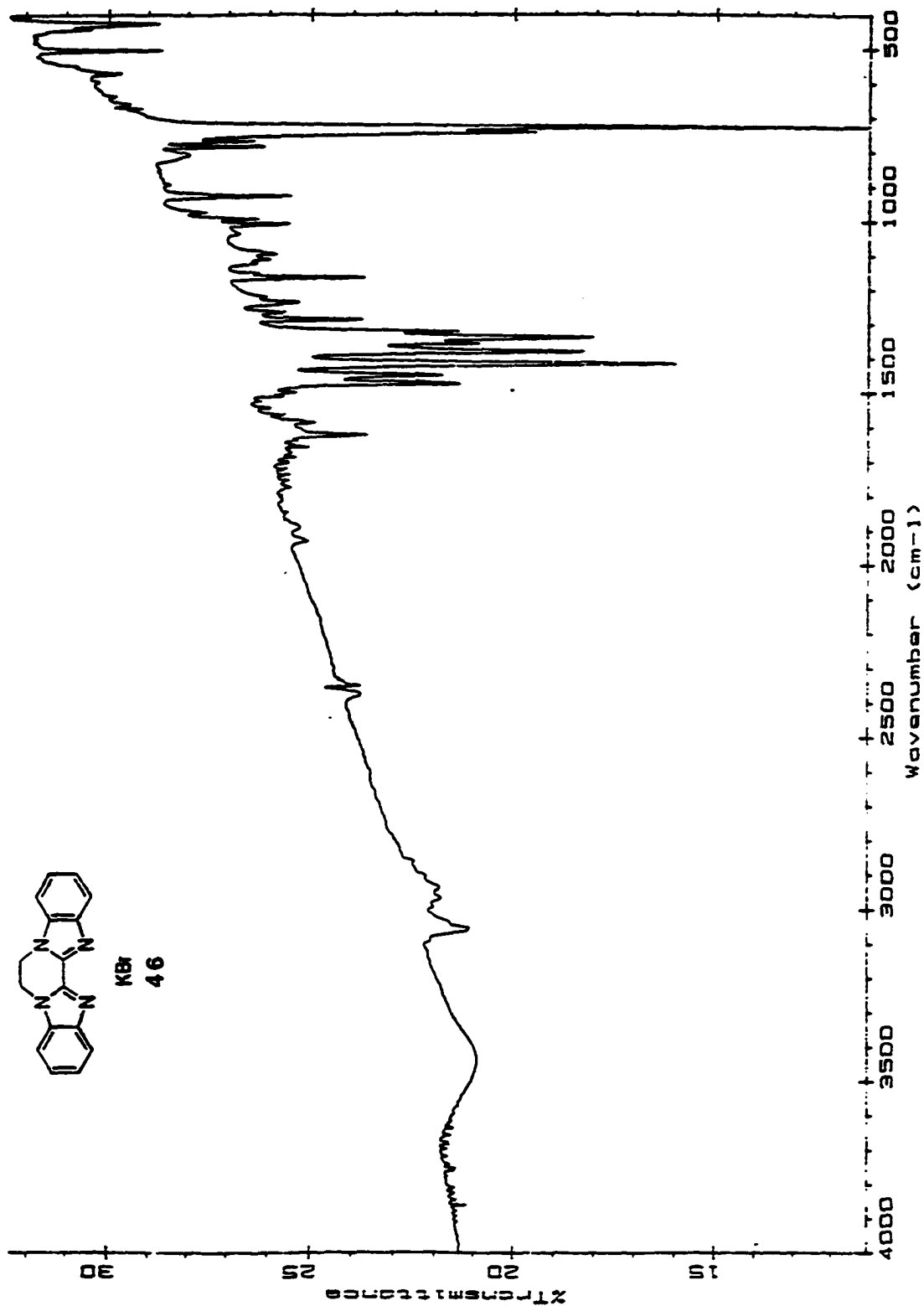

2.6625
2.6464
2.6312
2.6151
2.5990

4.819
4.658
4.497

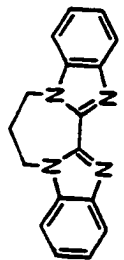

CDCl₃
47

7.9028
7.8909
7.8808
7.8740
7.8698
7.8613
7.3156
7.3062
7.3003
7.2918
7.2774
7.2715
7.2673
7.2554

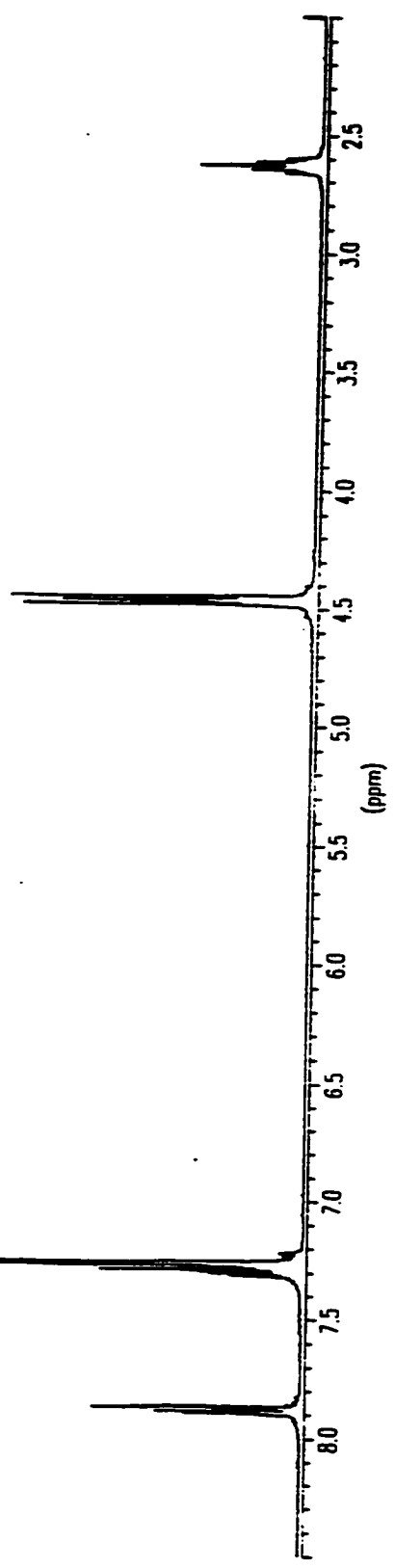

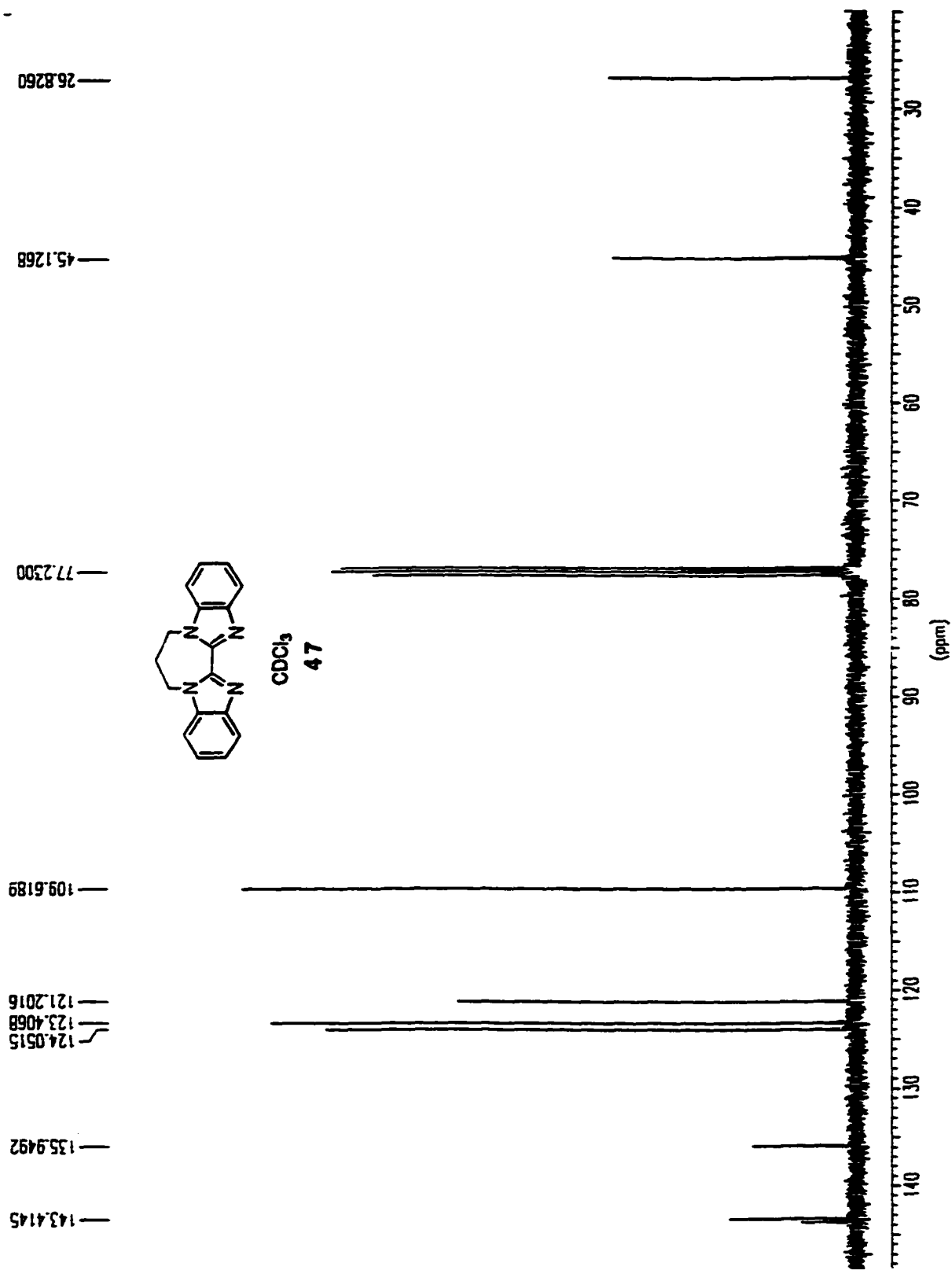

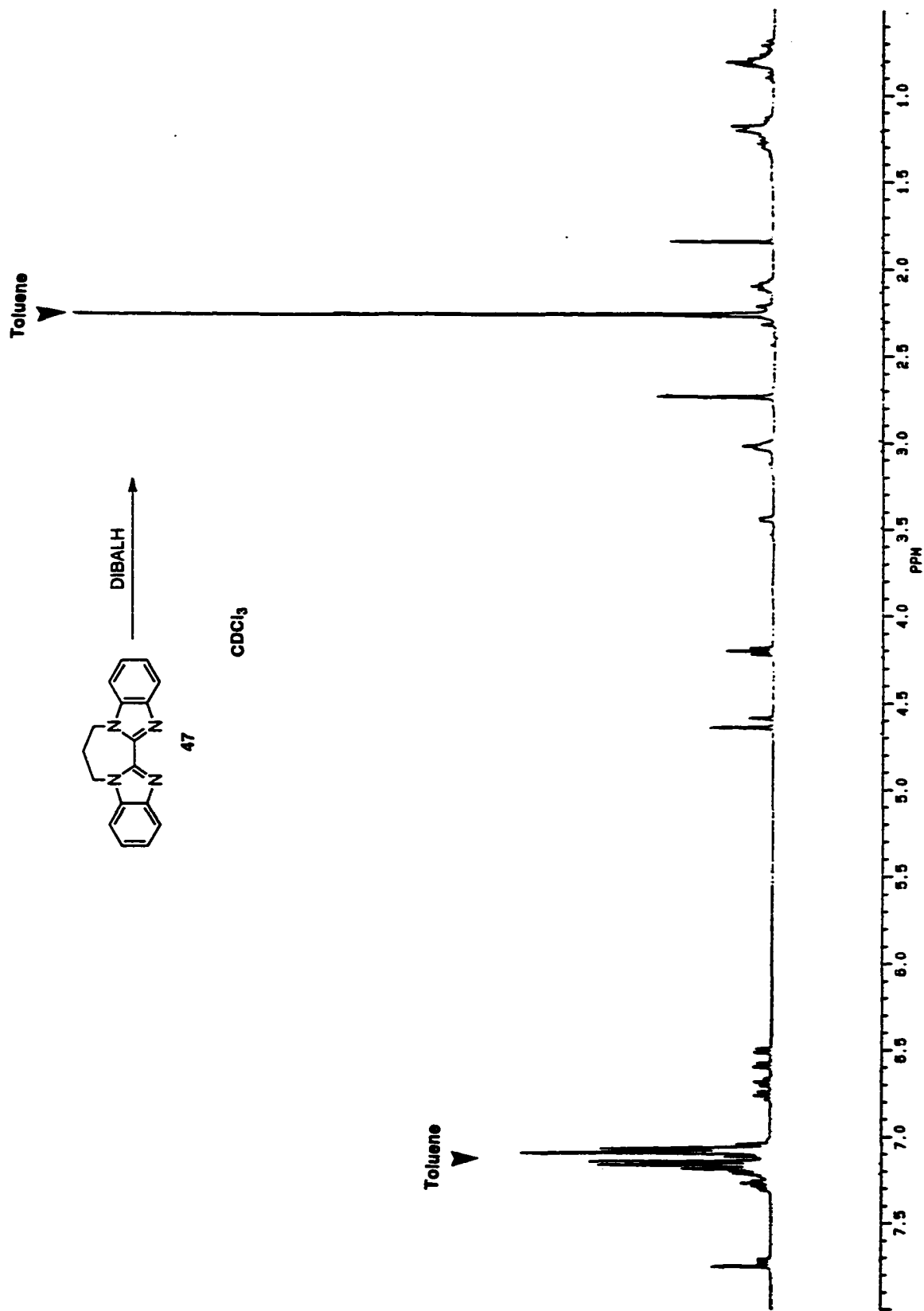

275

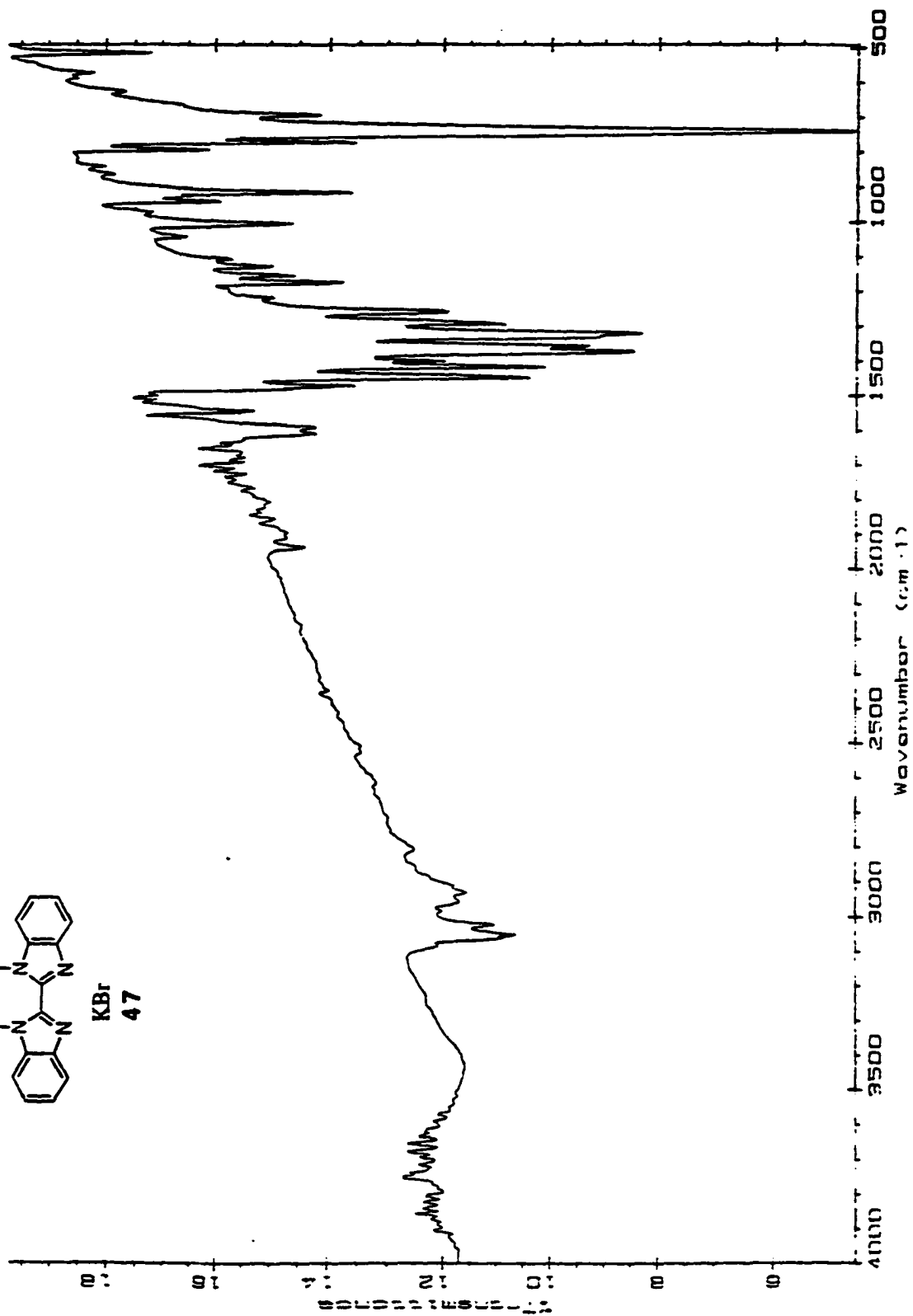
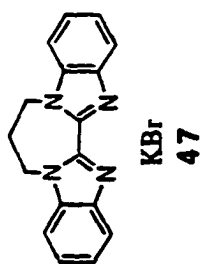

— 39.5100
— 42.2060

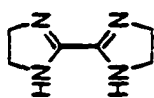

DMSO-*d*₆

11

— 146.3614

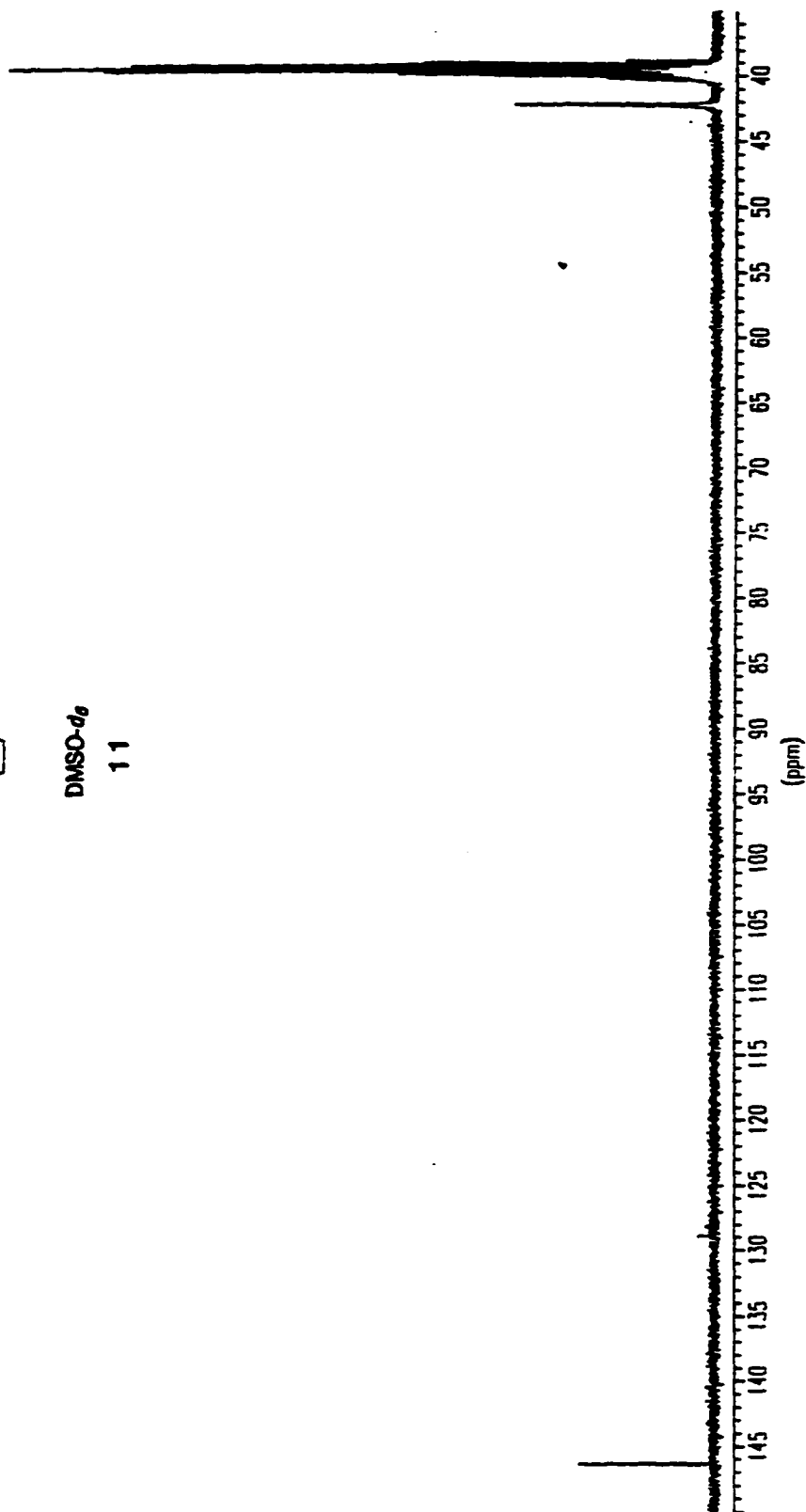

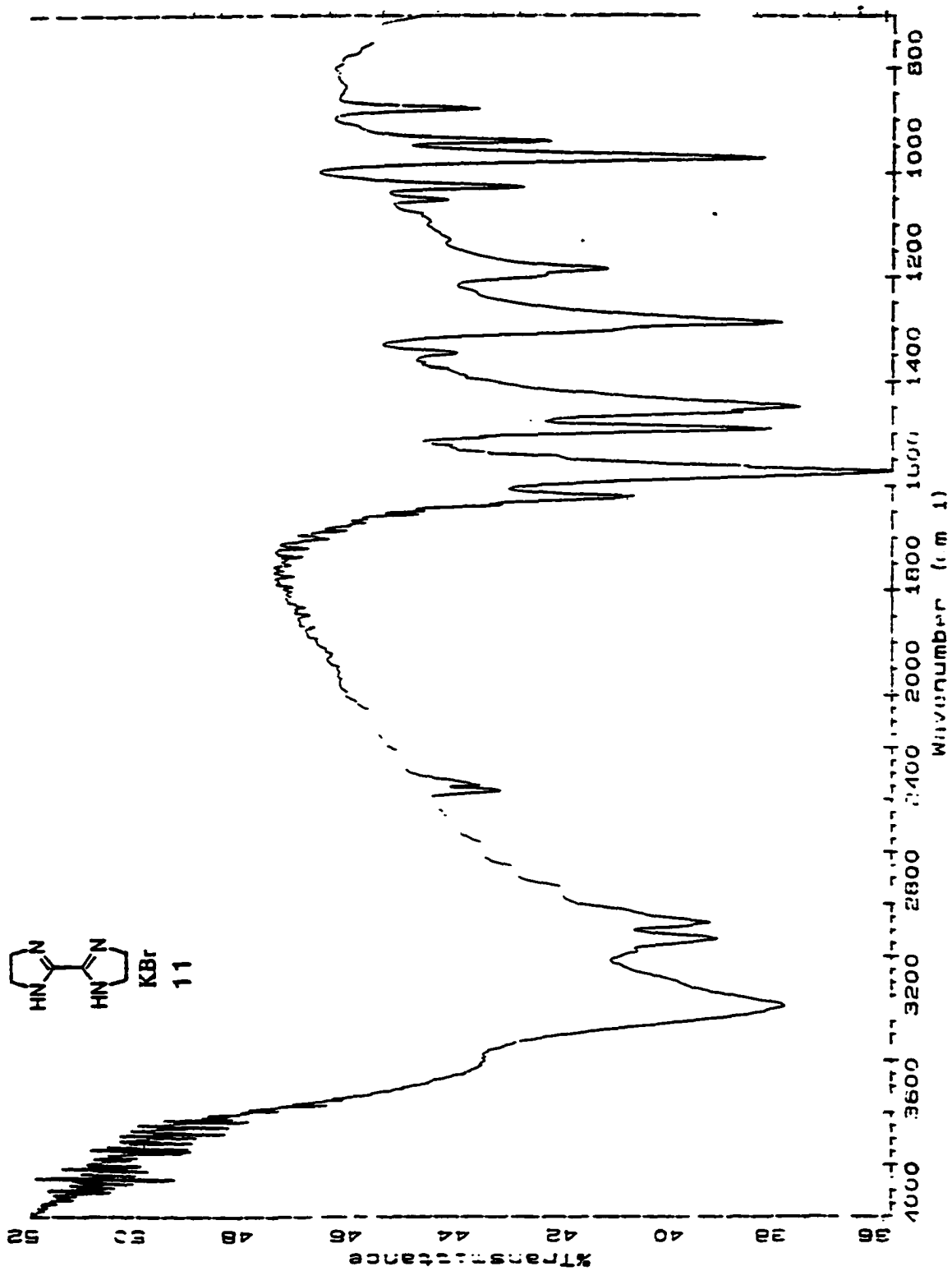

0.1458

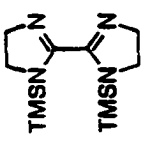

CDCl₃
49

3.4608
3.4328
3.4048

3.7887
3.7607
3.7328
3.6523

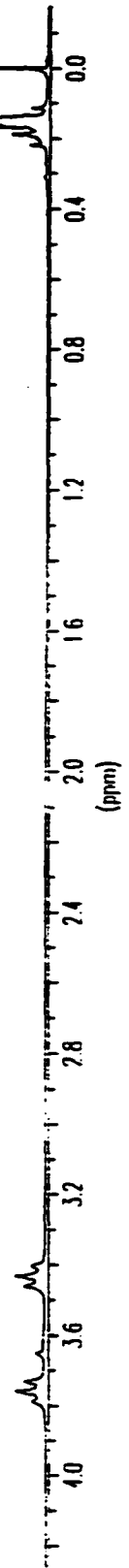
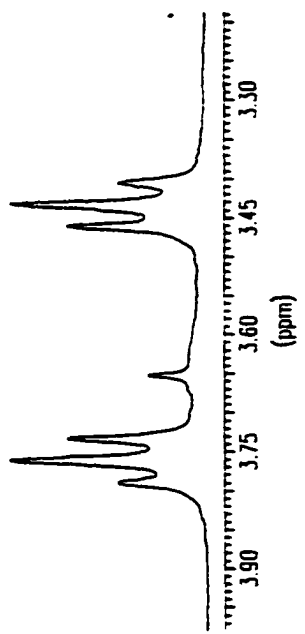

1.2711

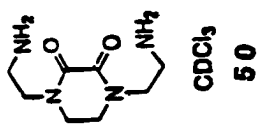

2.9633
2.9455
2.9278

3.6438
3.5565
3.5387
3.5209

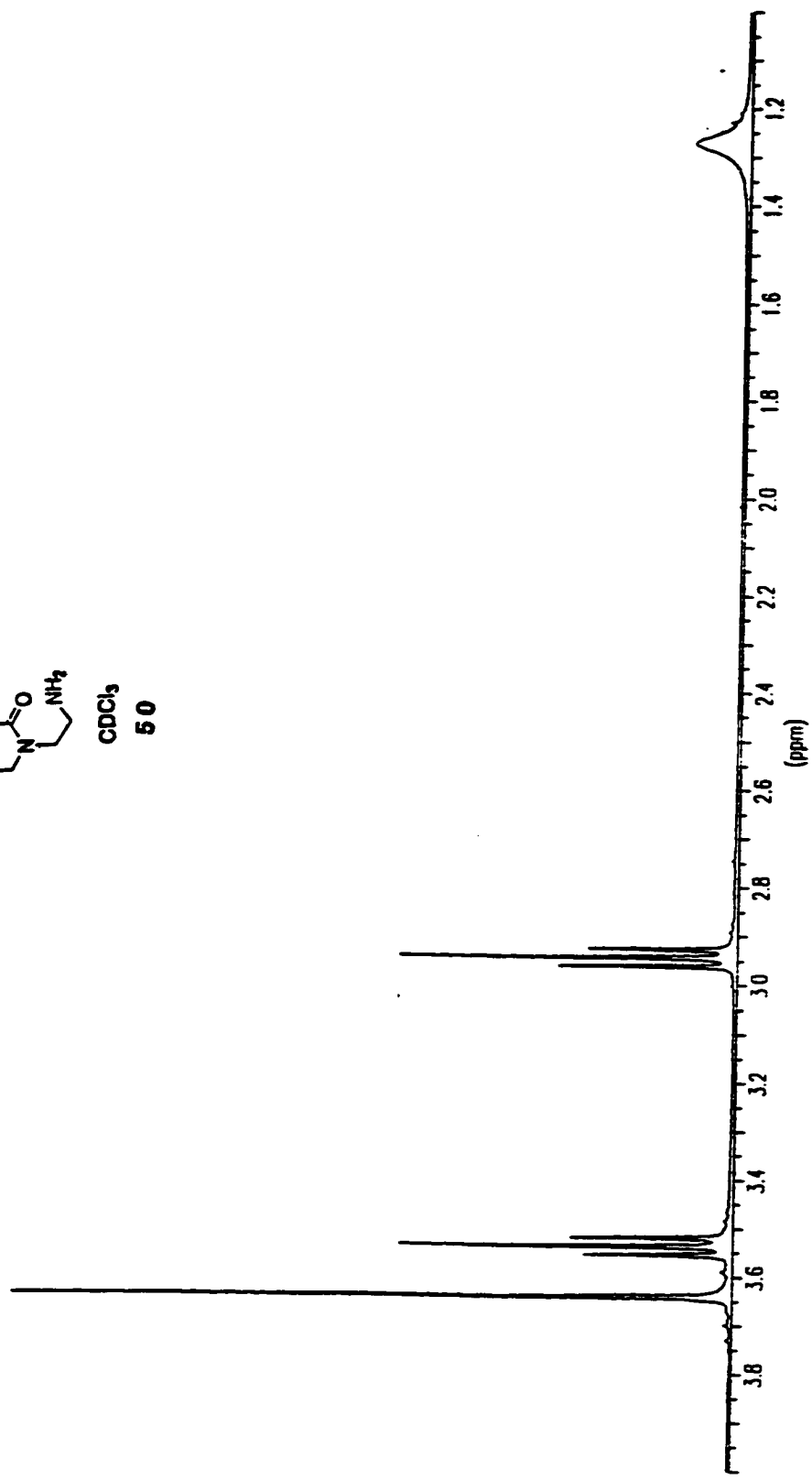

— 39.9179
— 45.6030
— 50.7606

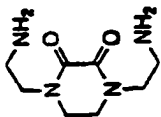

CDCl₃
50

— :58.0229

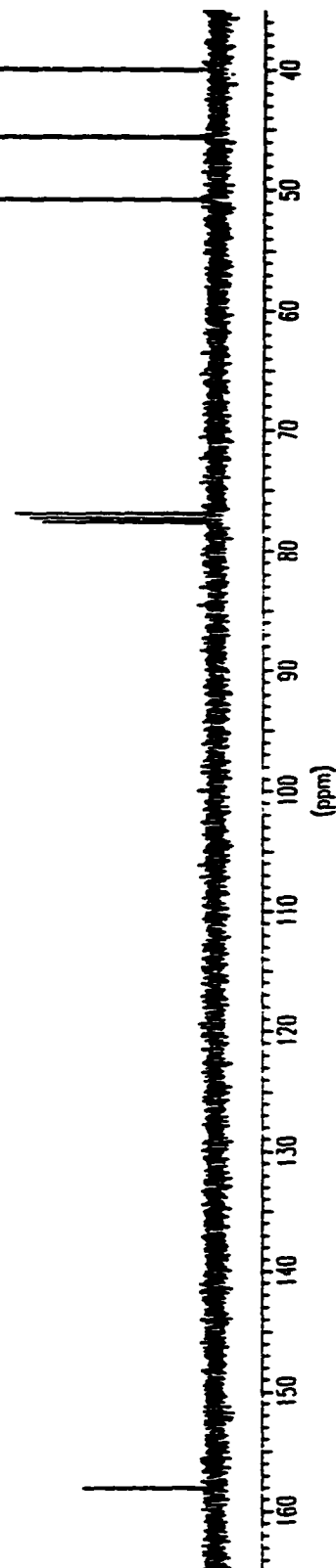

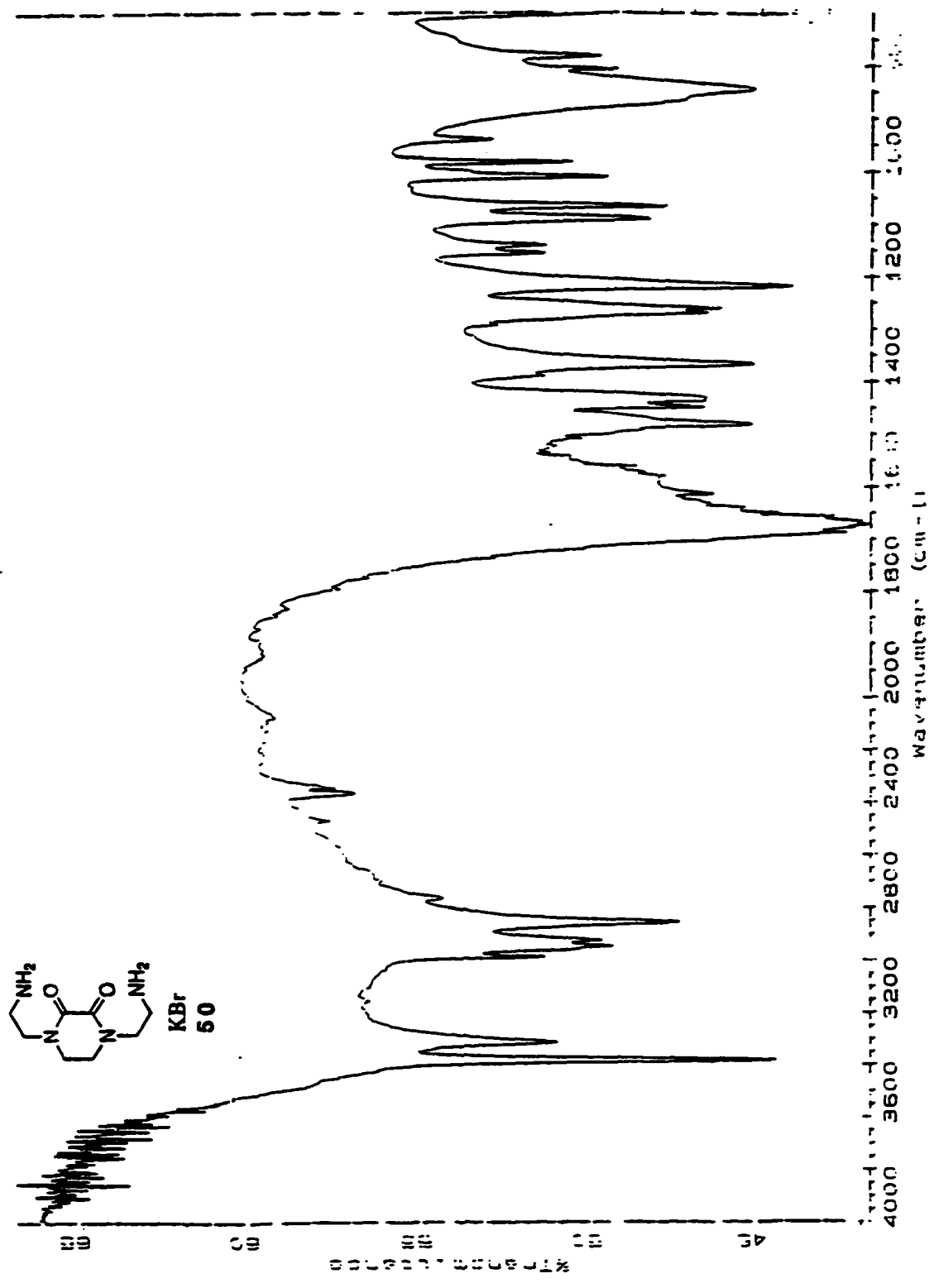

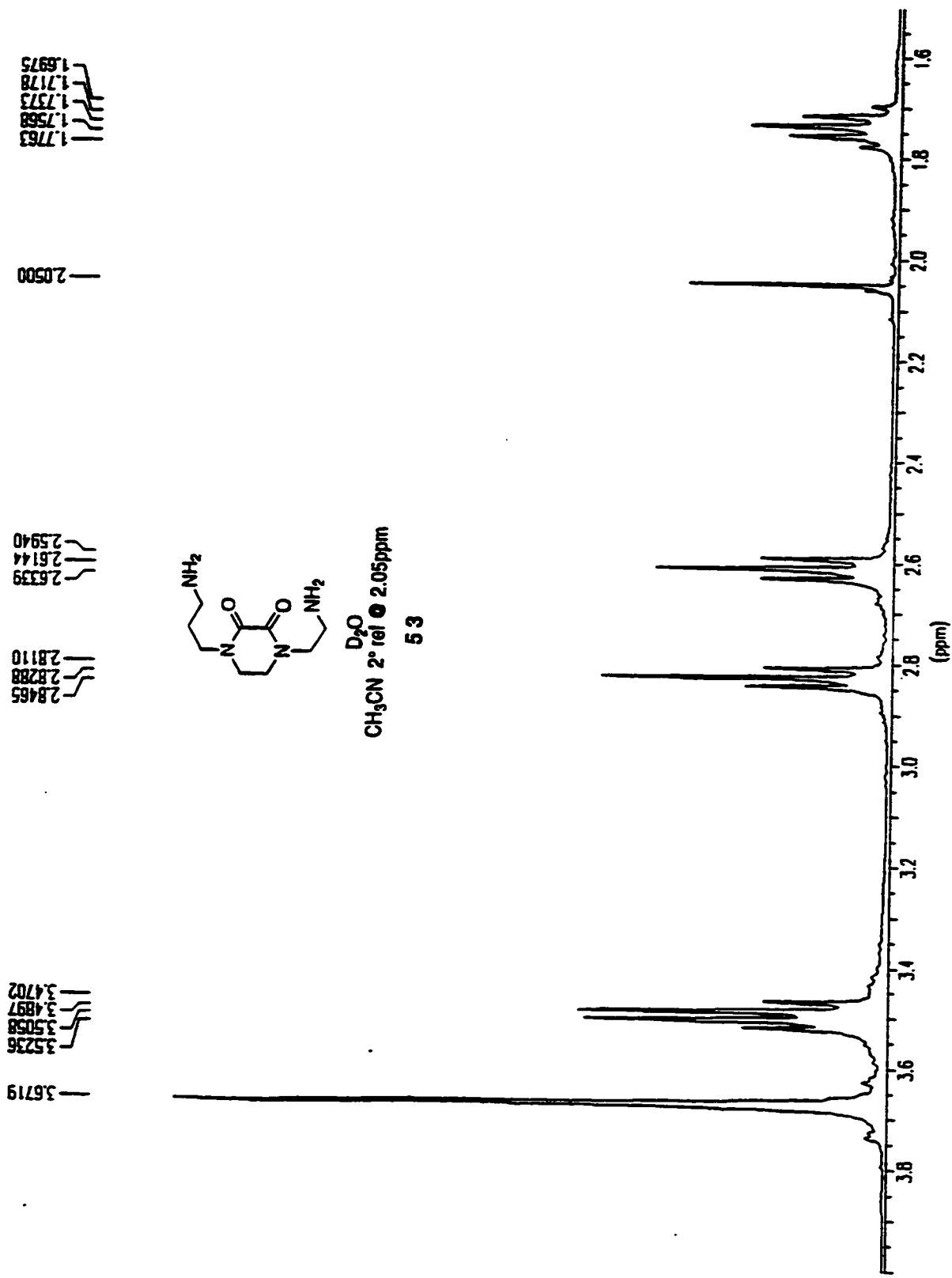

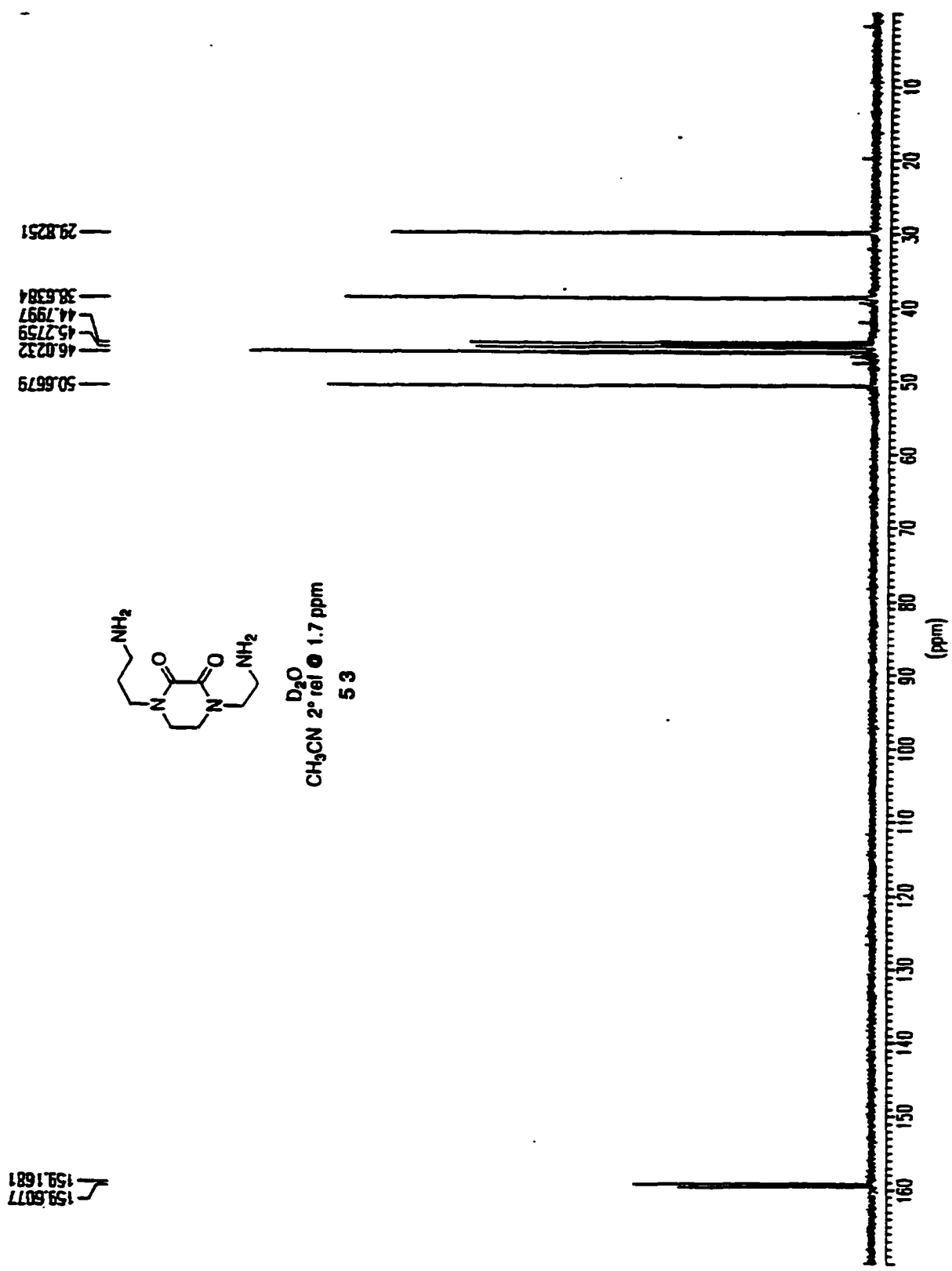

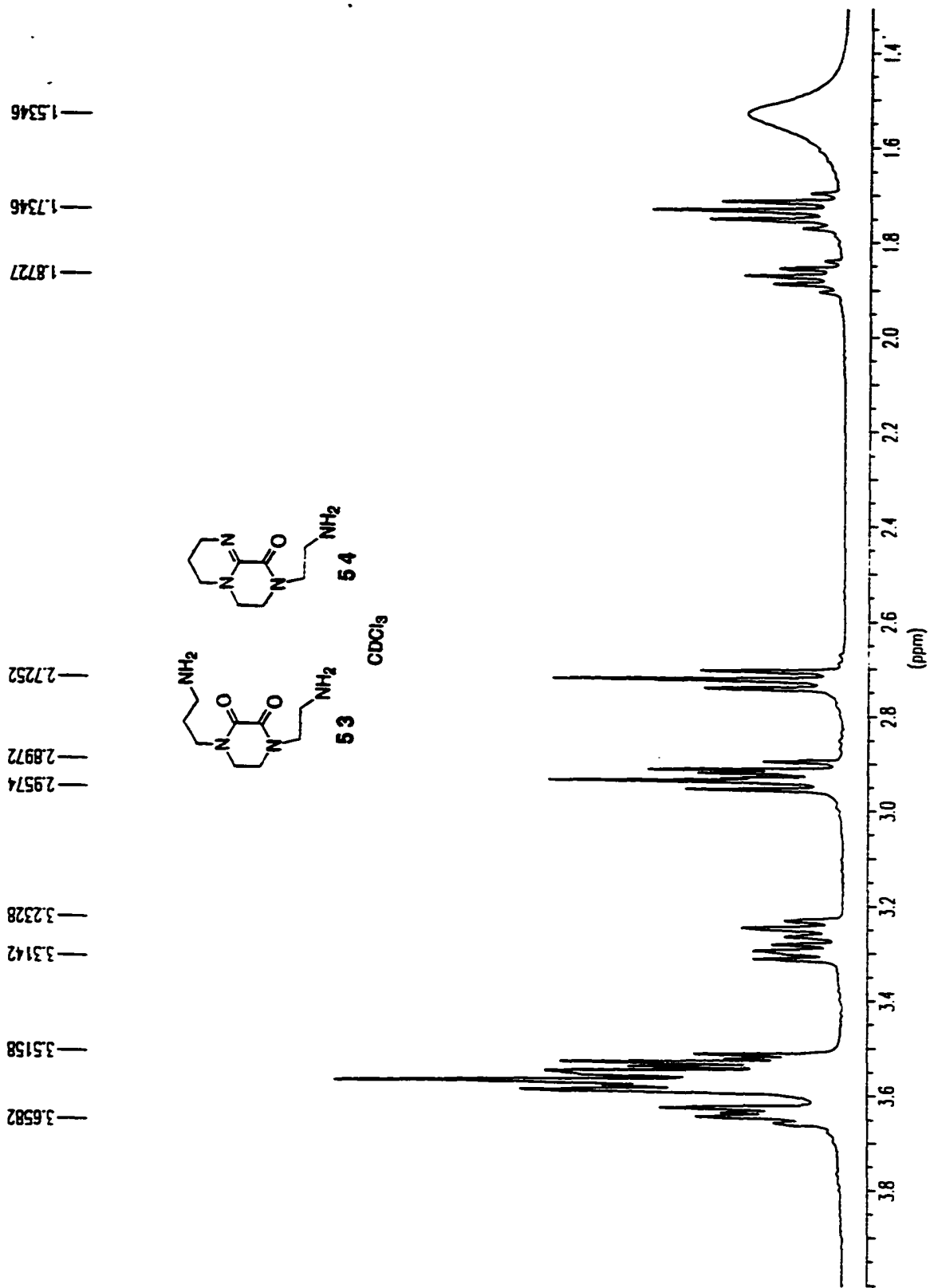

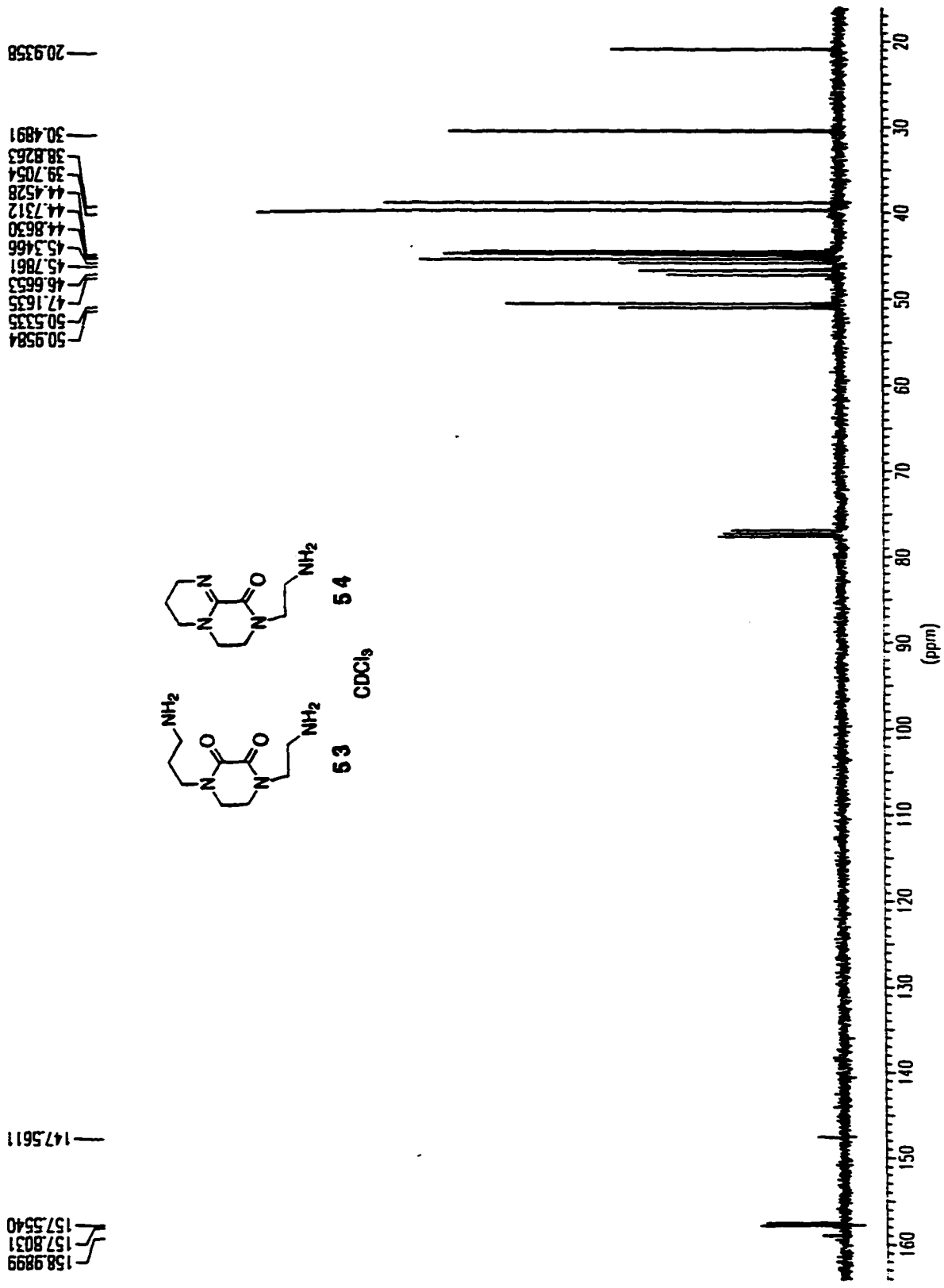

3.2818
3.2048

3.7048

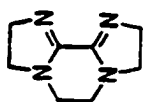

CD₃CN

16

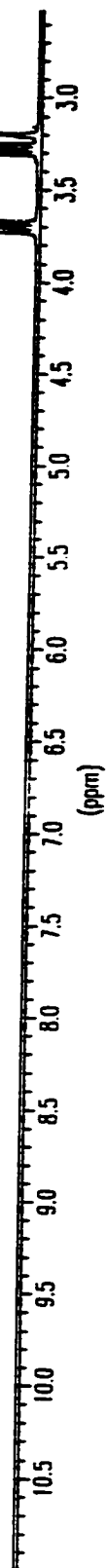

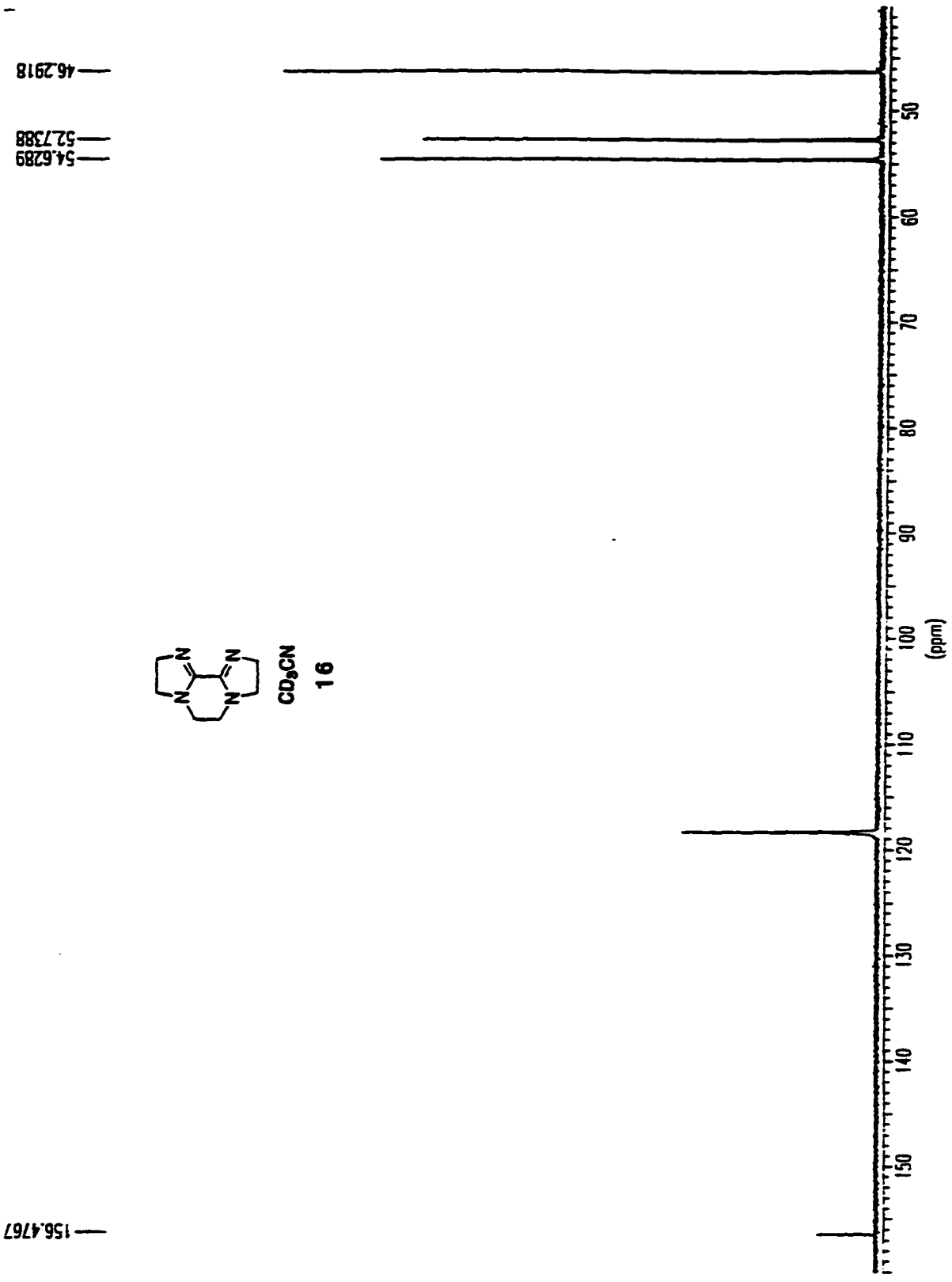

— 3.3295
— 3.4753
— 3.8205

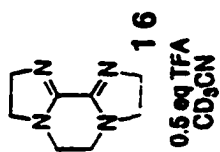

— 8.1347

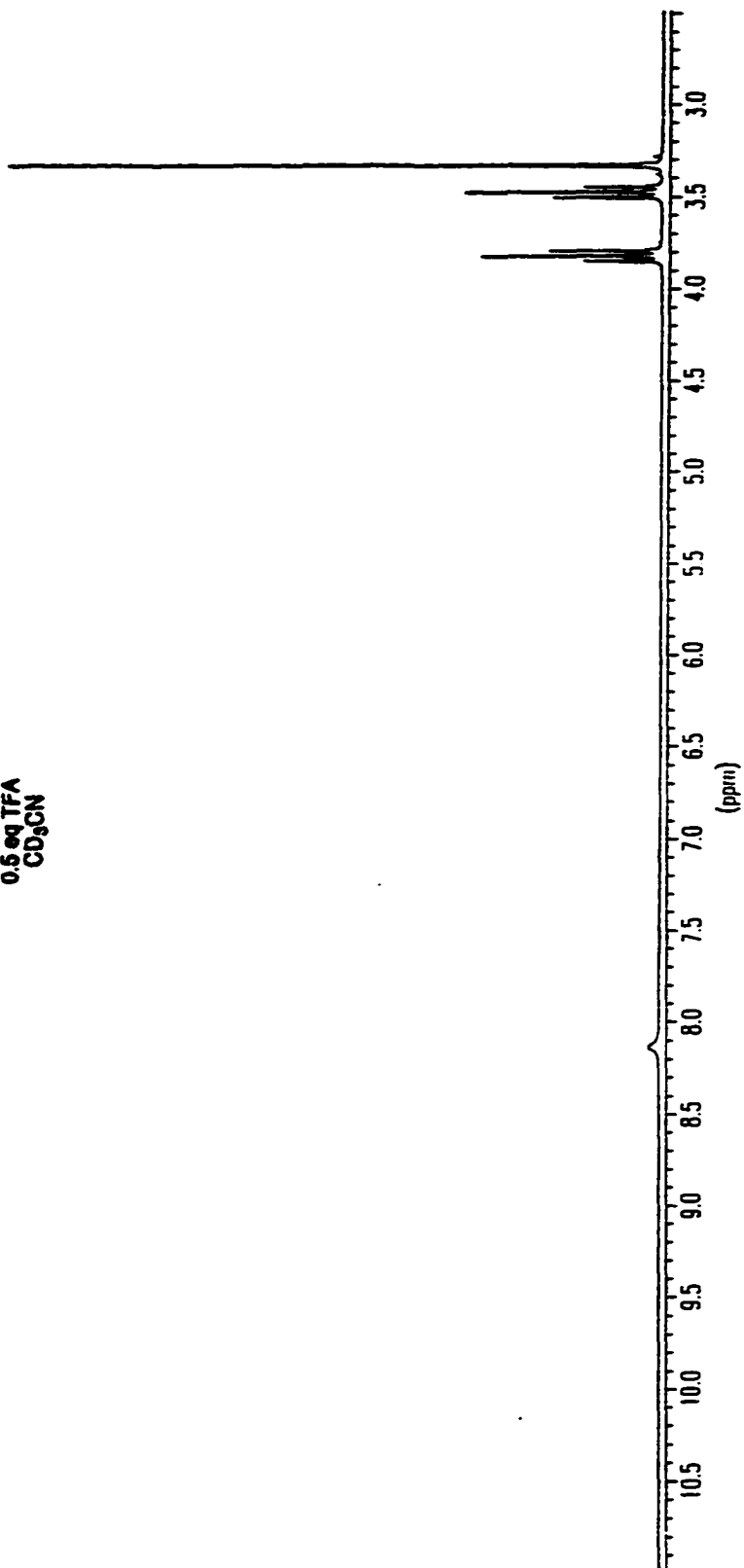

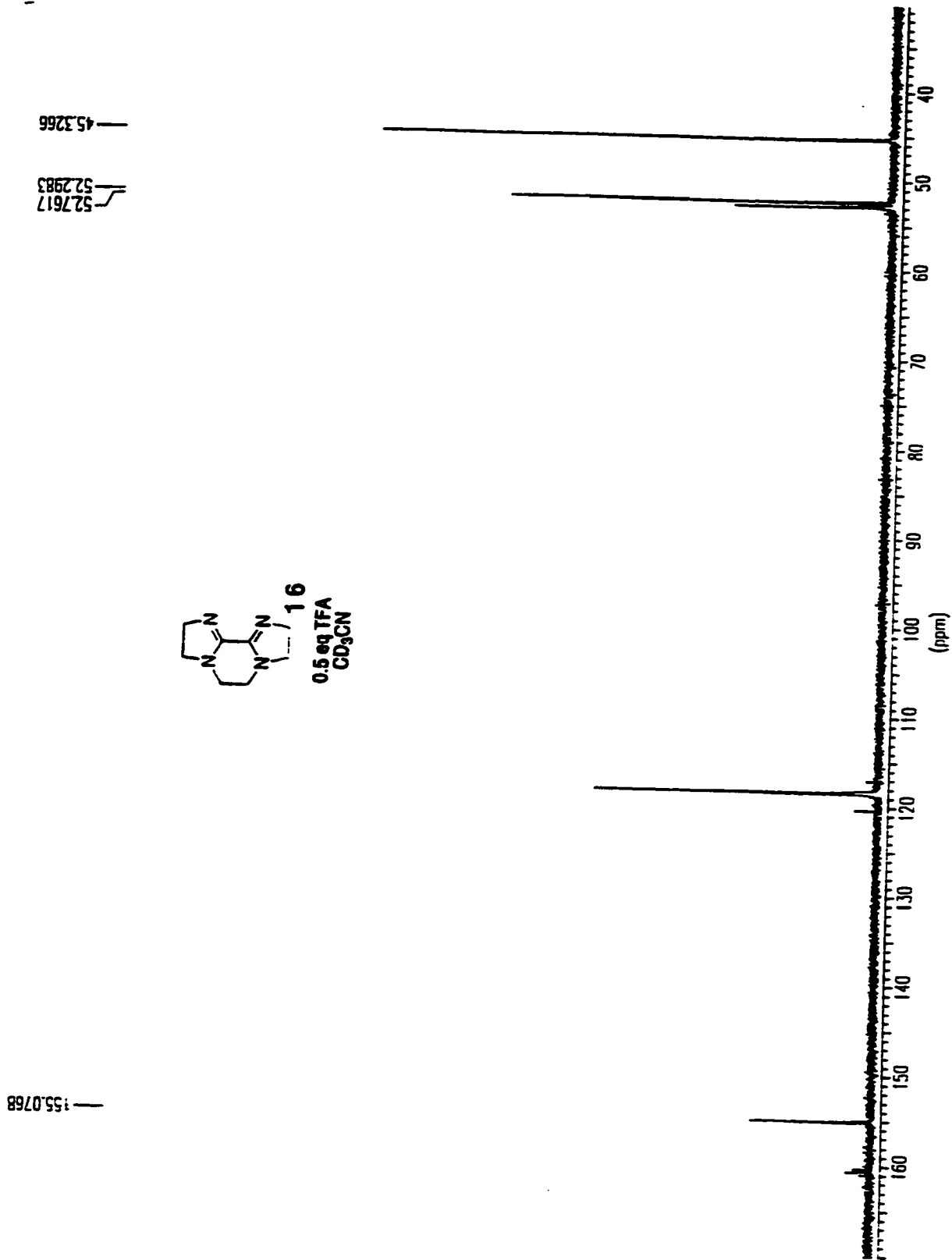

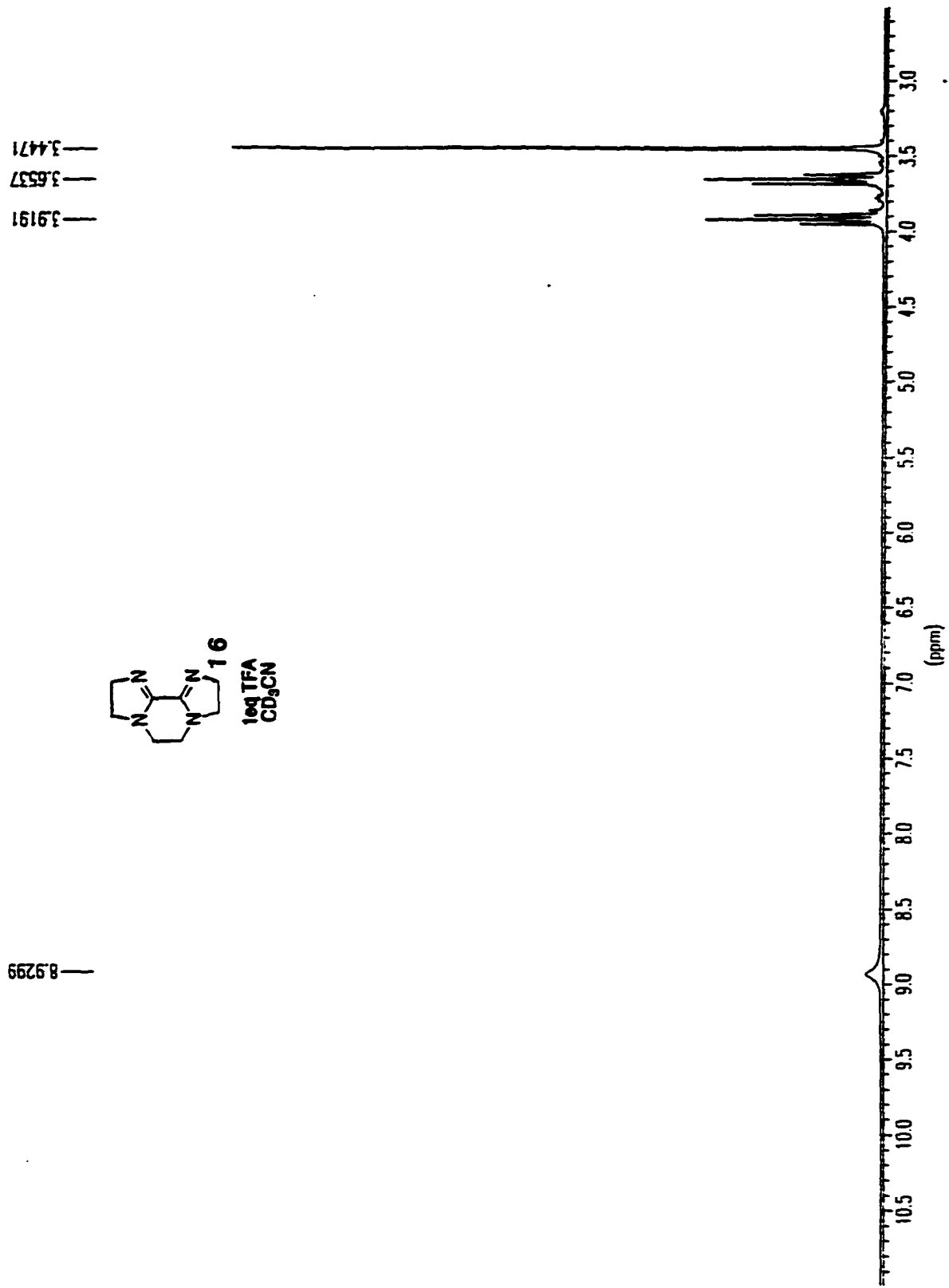

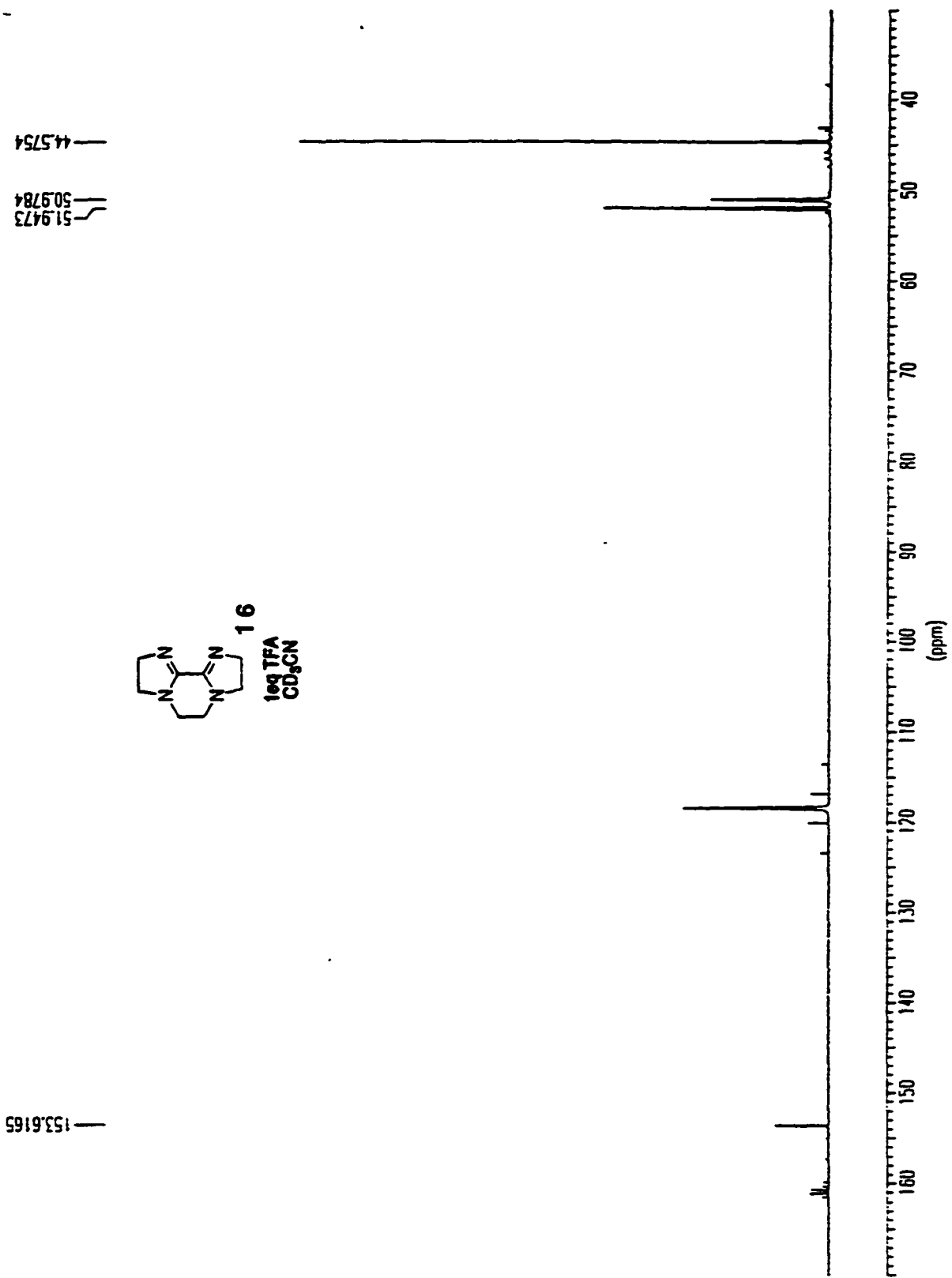

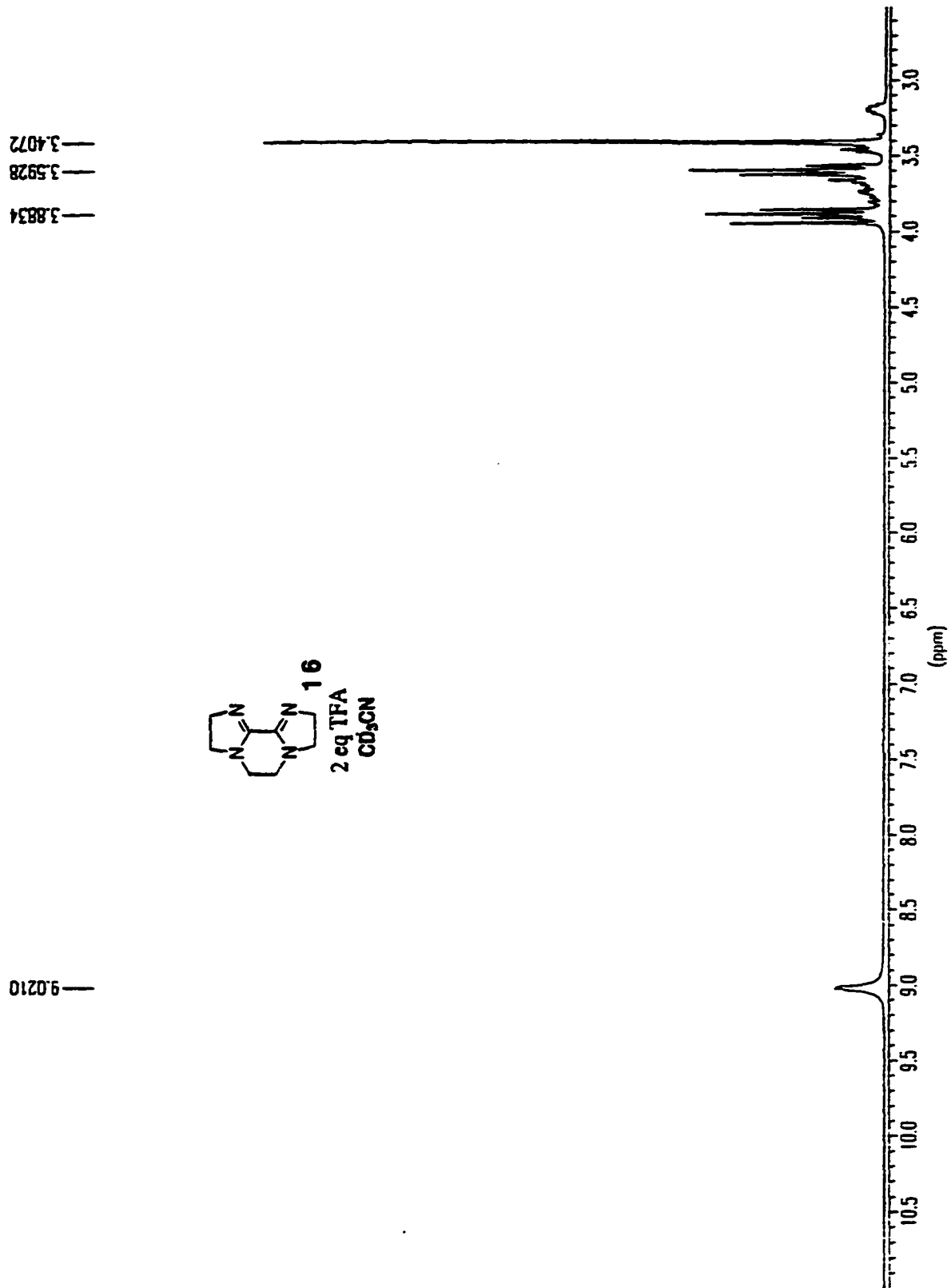

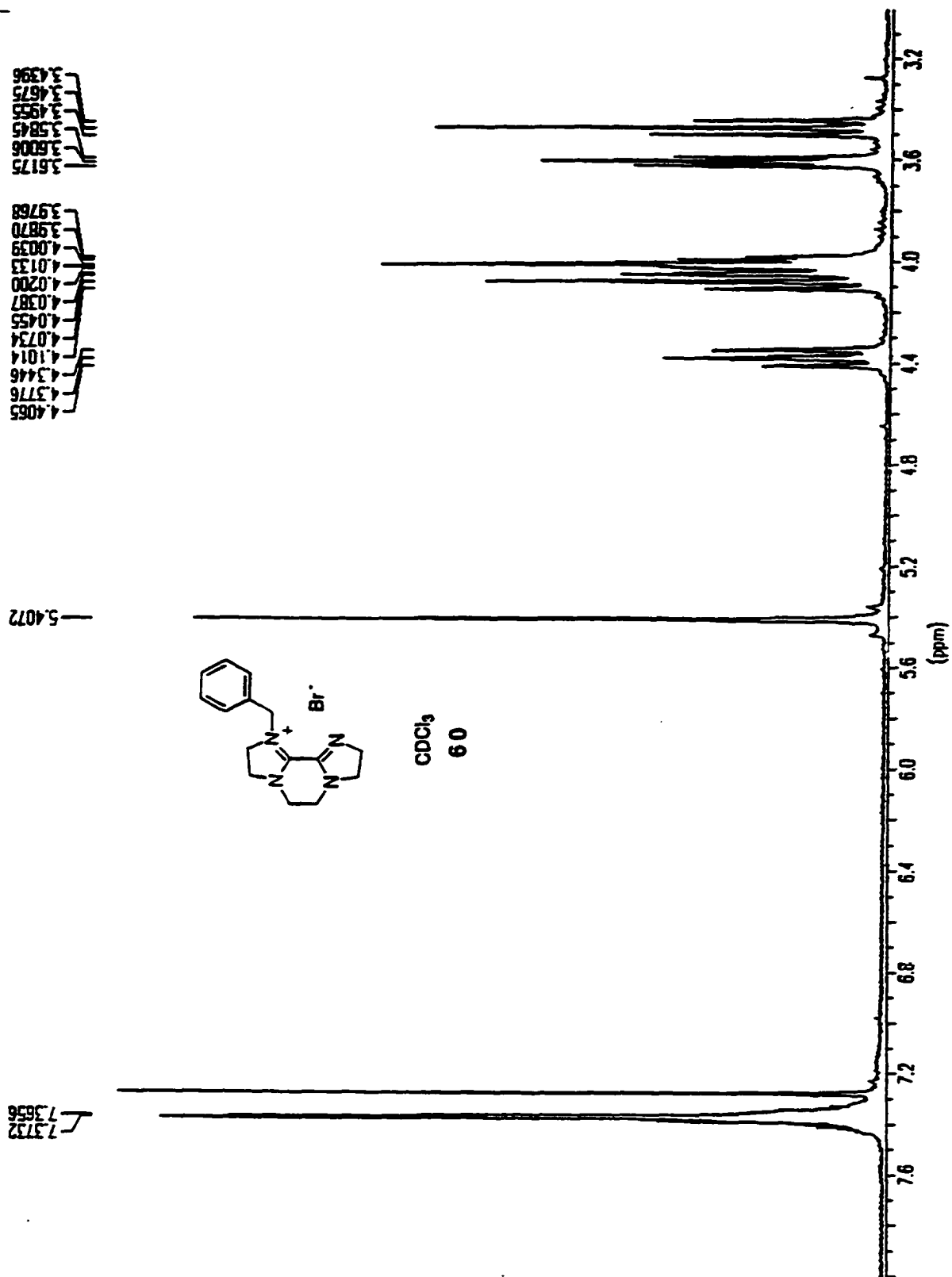



43.6176
 44.9363
 45.6836
 46.2404
 46.5114
 46.7019
 47.0316
 47.5737
 48.6800
 51.0976
 52.0207
 52.5116
 53.1196
 53.9768
 55.4347
 57.1930
 57.3908
 59.1197

75.8161

125.2310
 126.6229
 126.8354
 126.9893
 128.0369
 128.1175
 128.3226
 128.9527
 137.7221
 138.8210
 140.3375

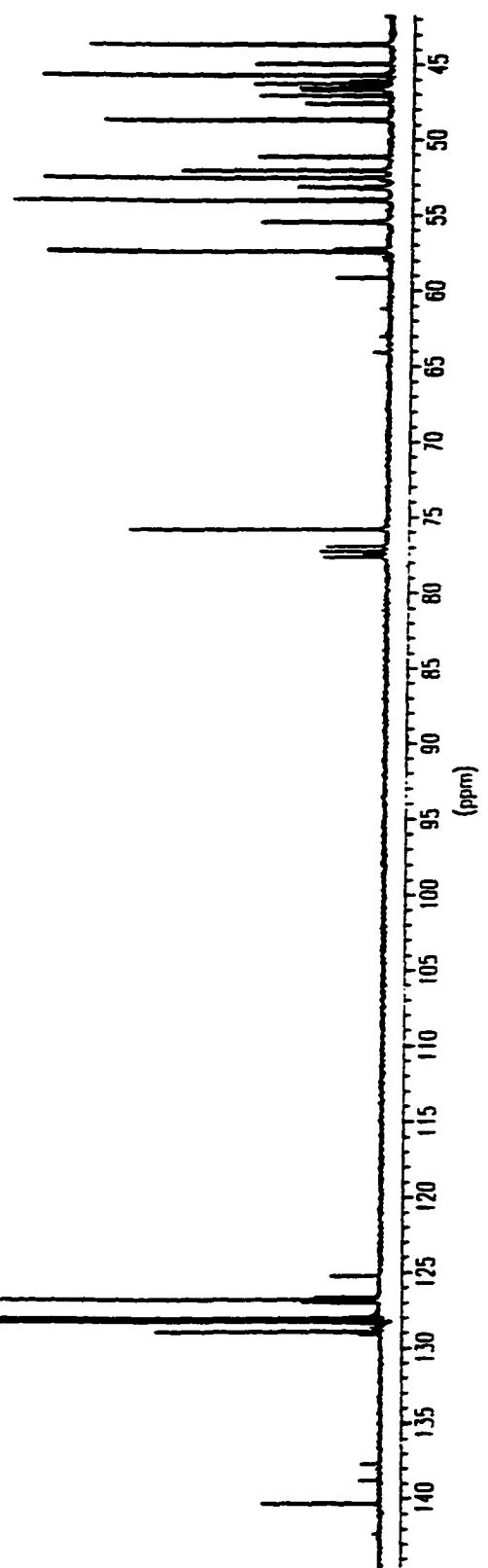
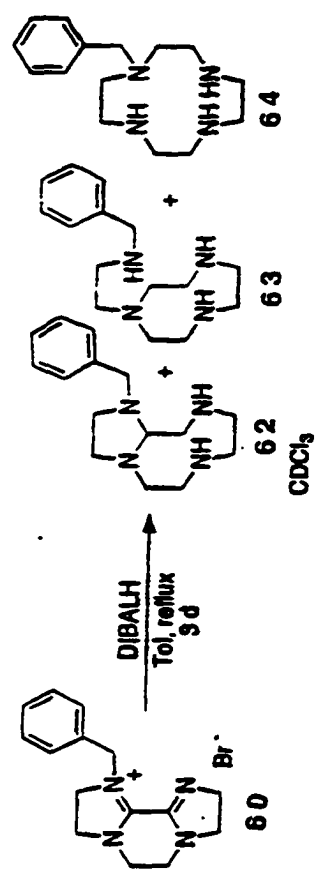

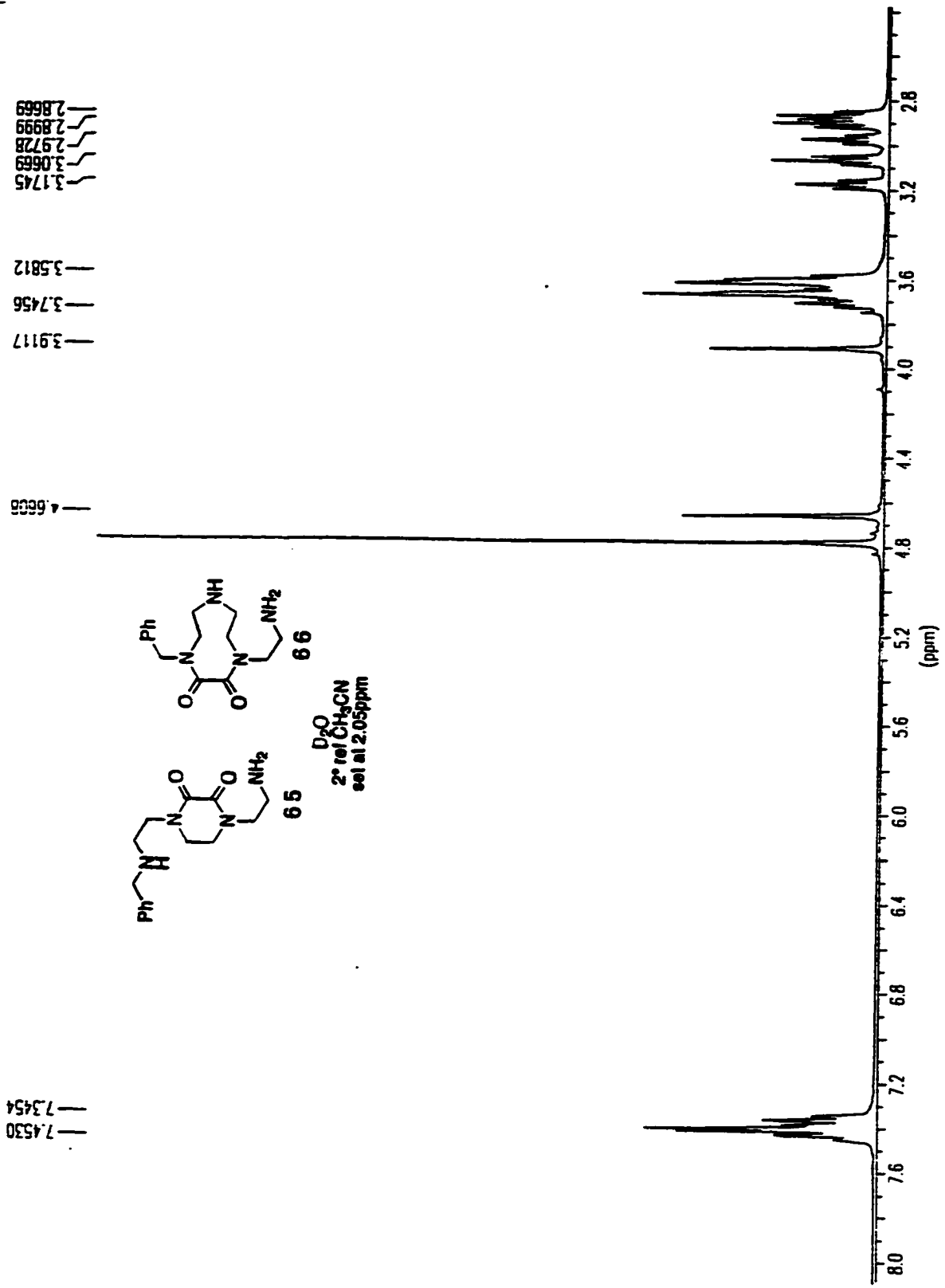

52.6313
51.5691
47.4591
47.0928
46.8364
46.2942
45.8840
45.2612
45.1660
45.0561
44.5433
39.3784
38.3234

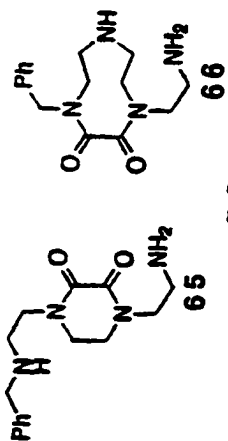

D₂O
2° ref CH₃CN
set at 1.7ppm

137.2117
136.0395
129.8416
129.7097
128.9771
128.8013

159.7322
159.5198
159.3073

300

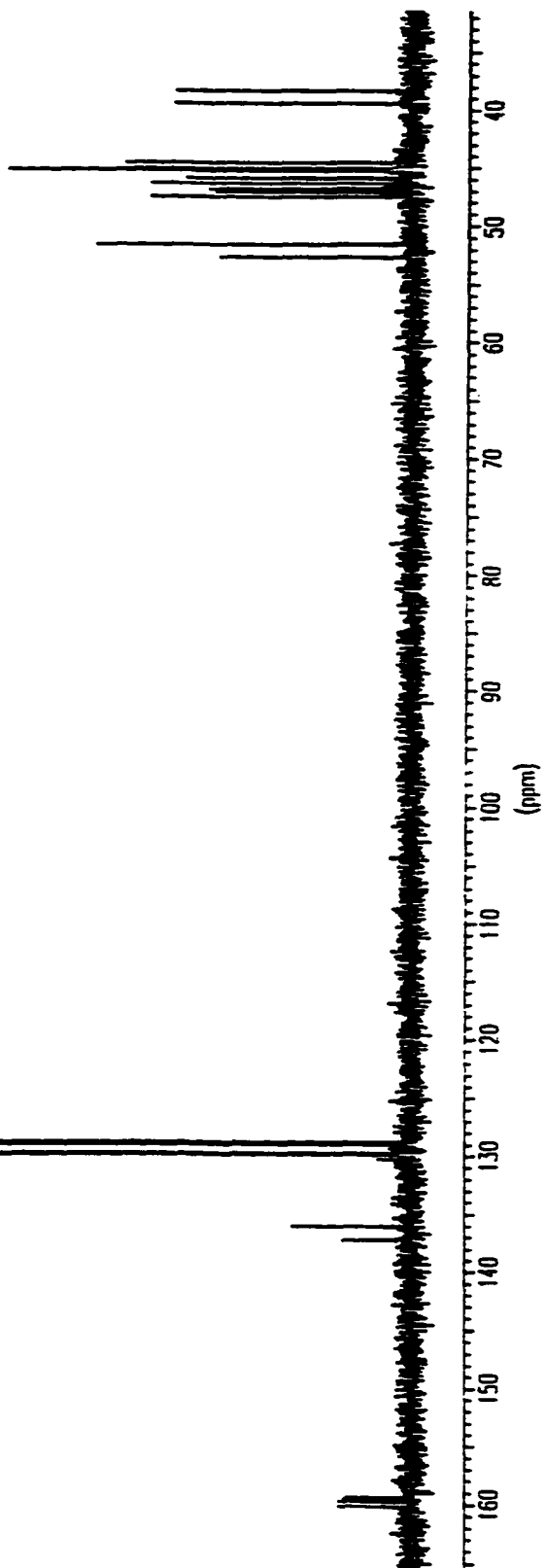

2.9624
 3.3658
 3.4680
 3.5030
 3.5443
 3.5871
 3.6207
 3.6704
 3.7446
 3.8959
 3.9645
 4.0584

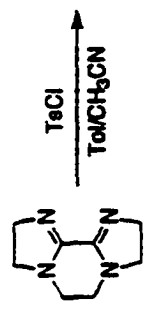
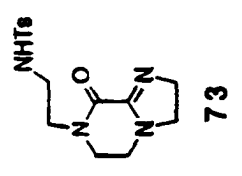

DMSO-*d*₆

7.3961
 7.4178
 7.6846
 7.7078
 7.9073

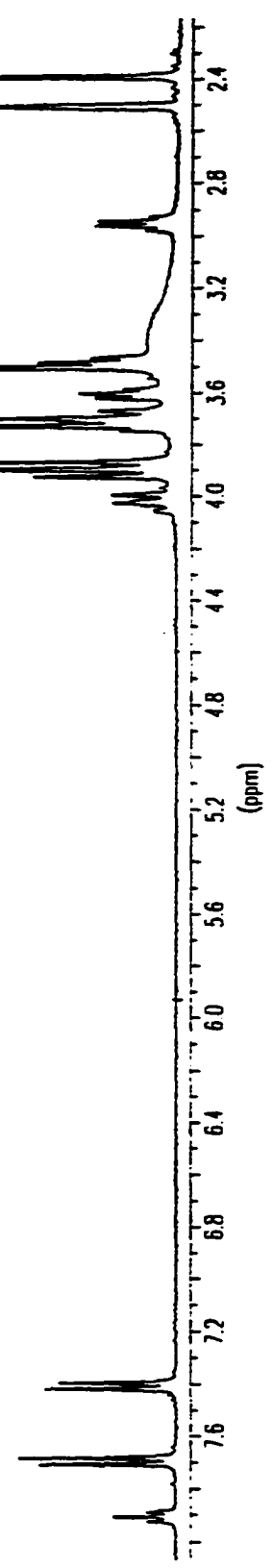

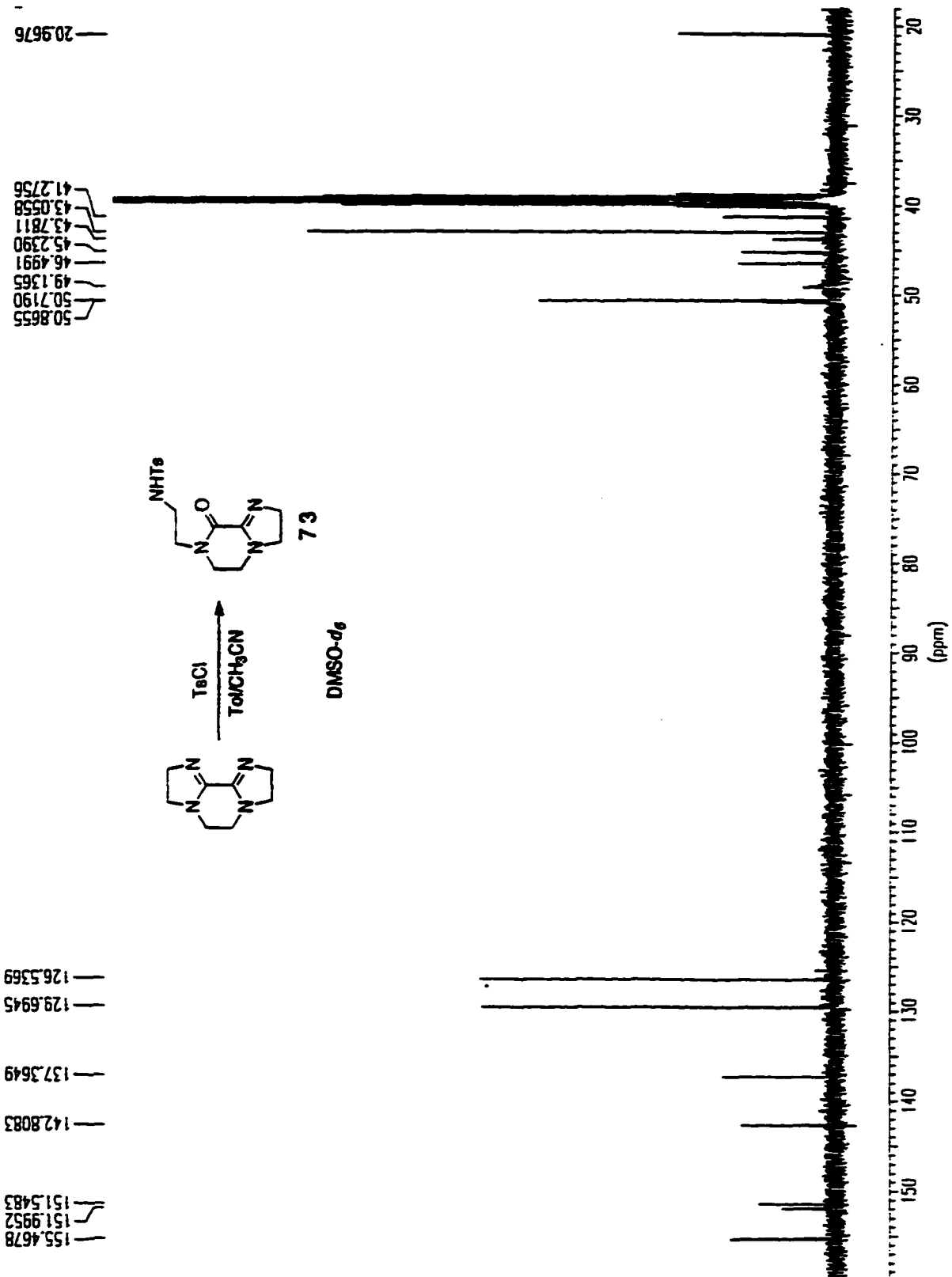

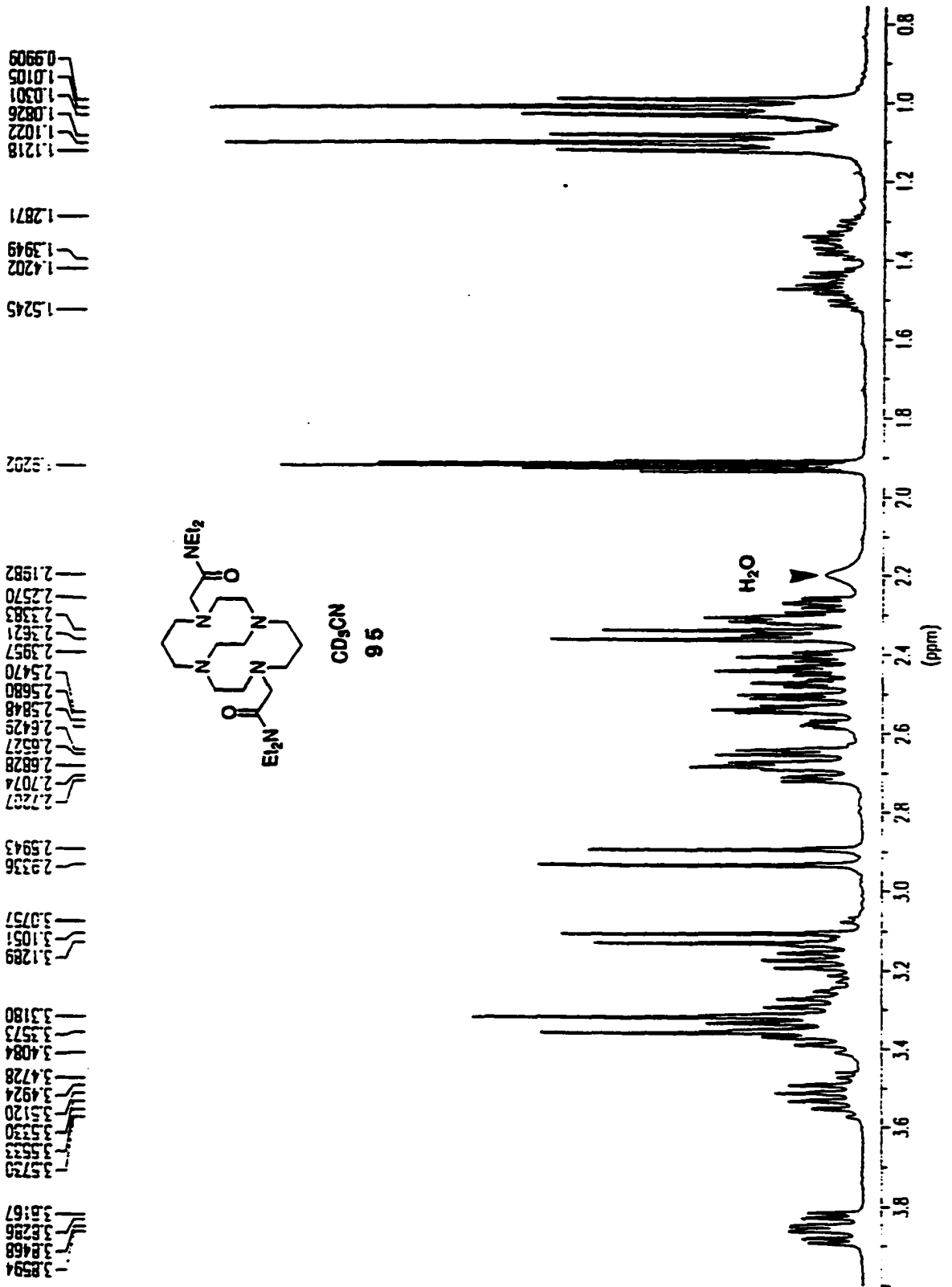

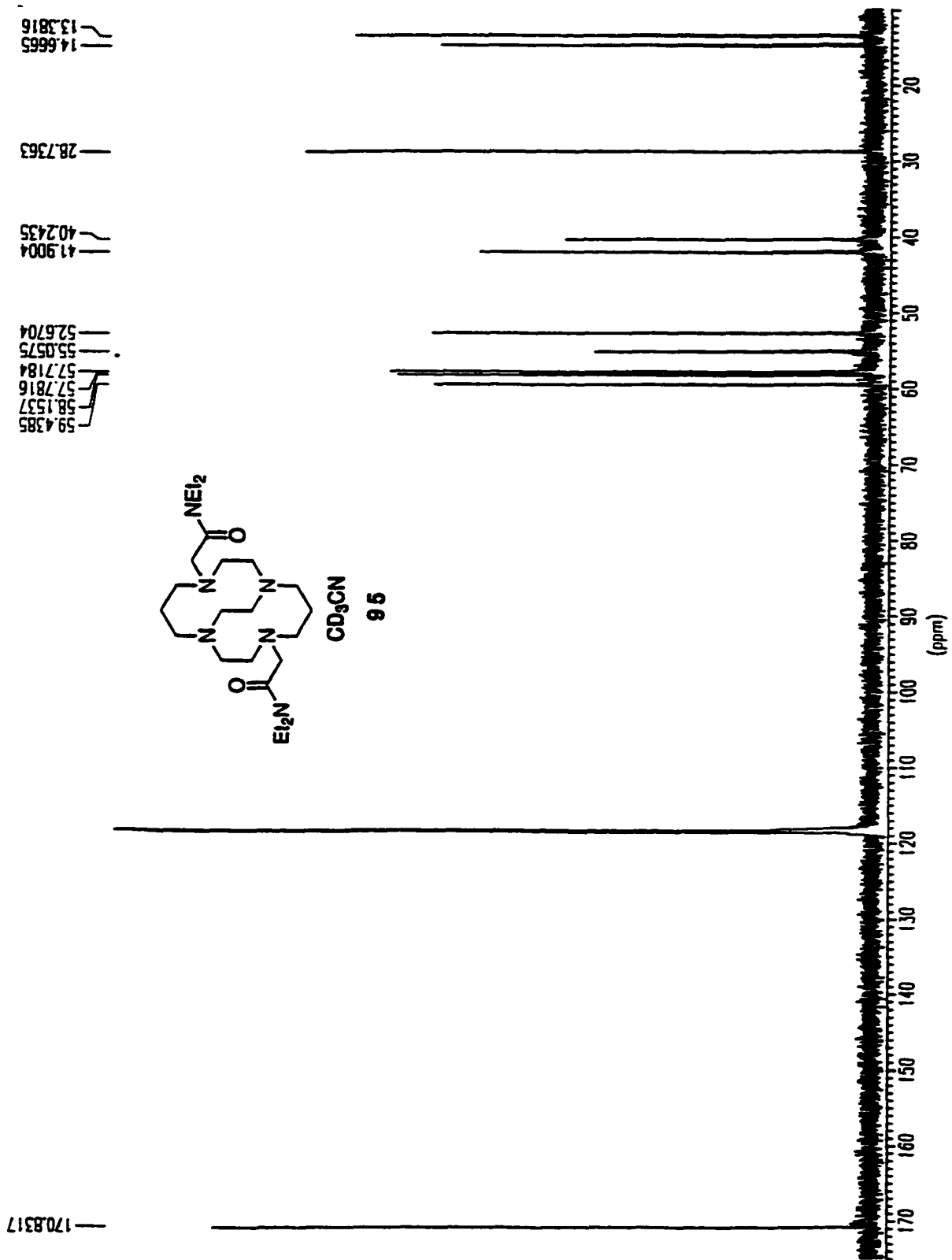

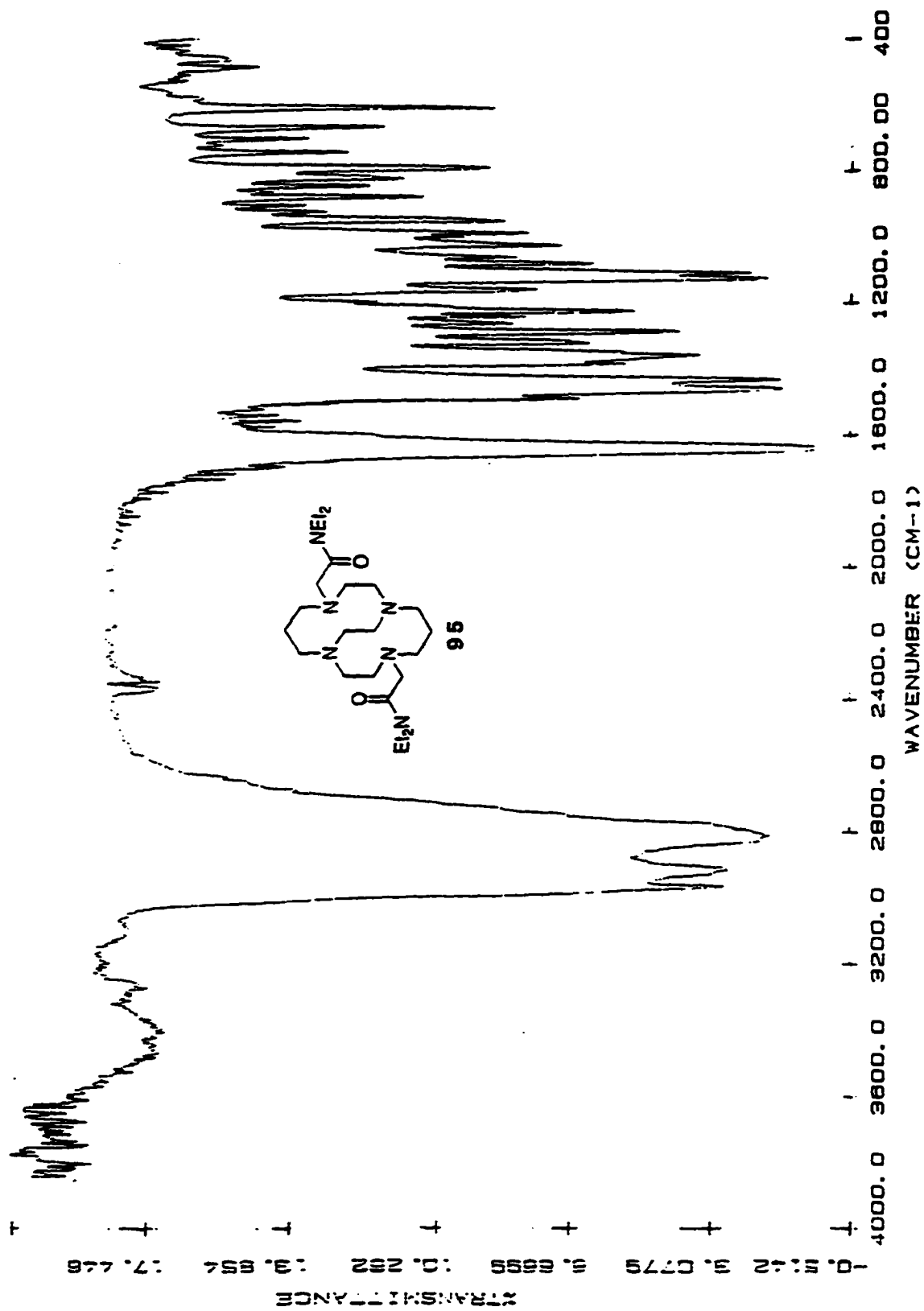

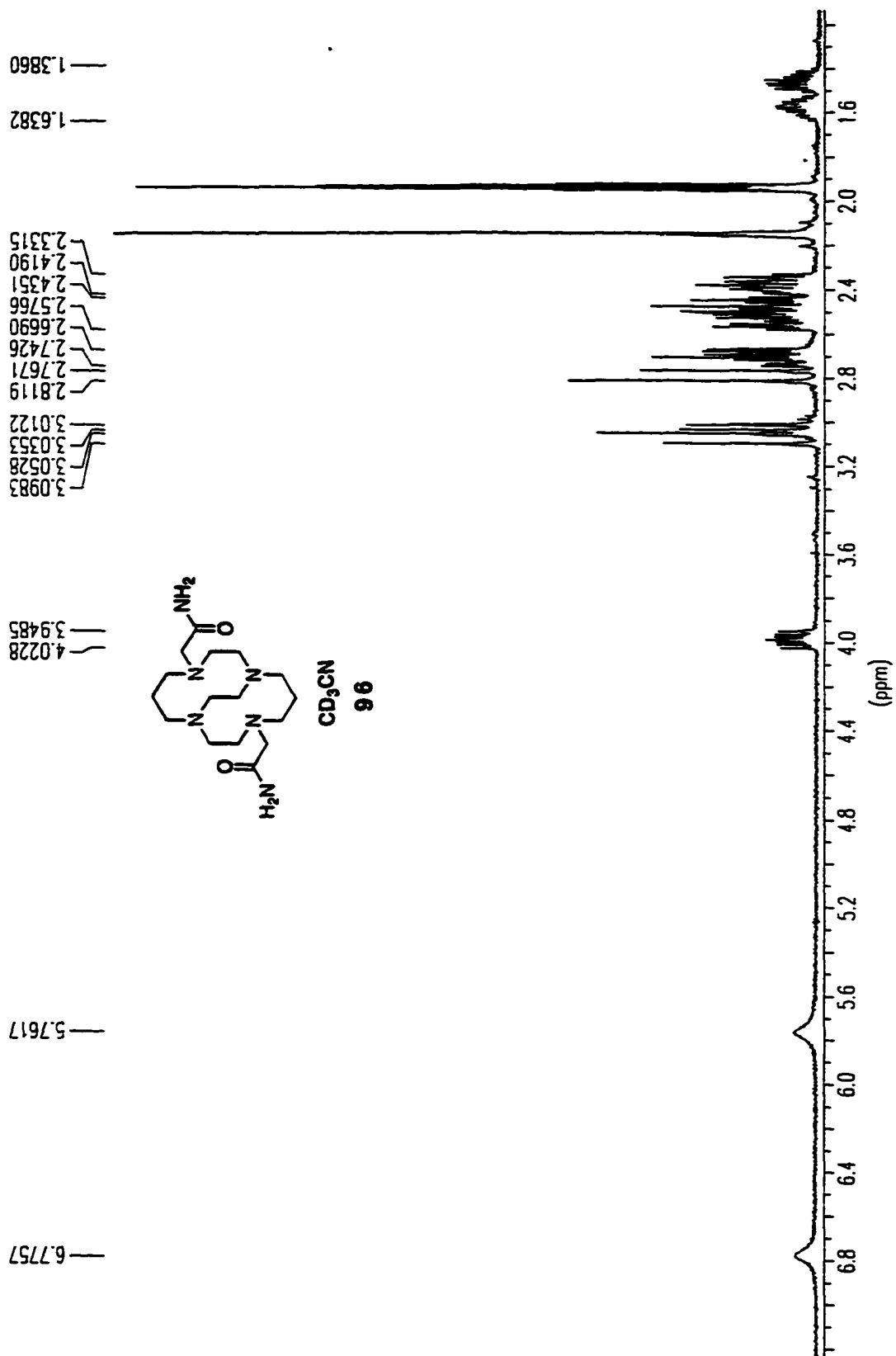

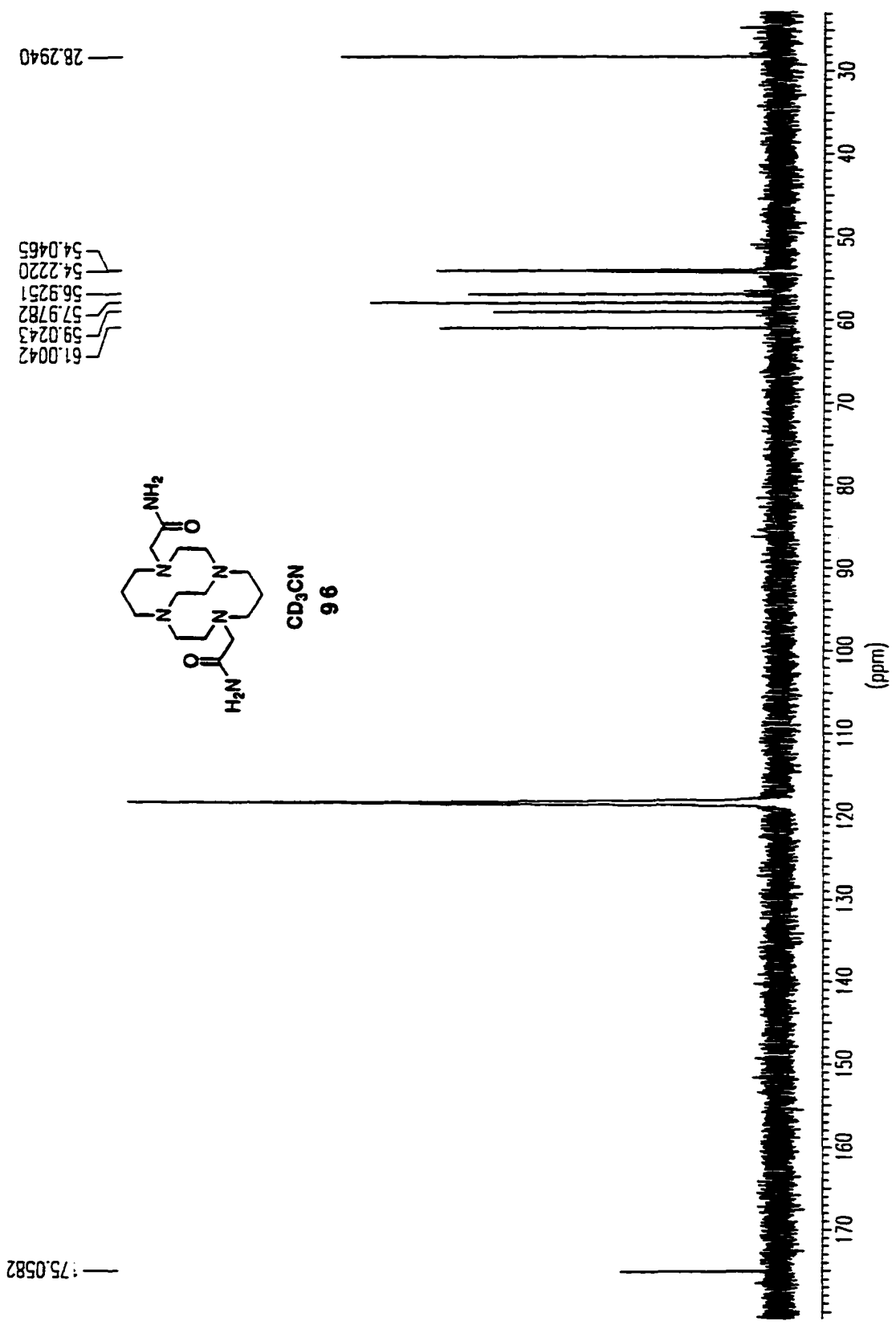

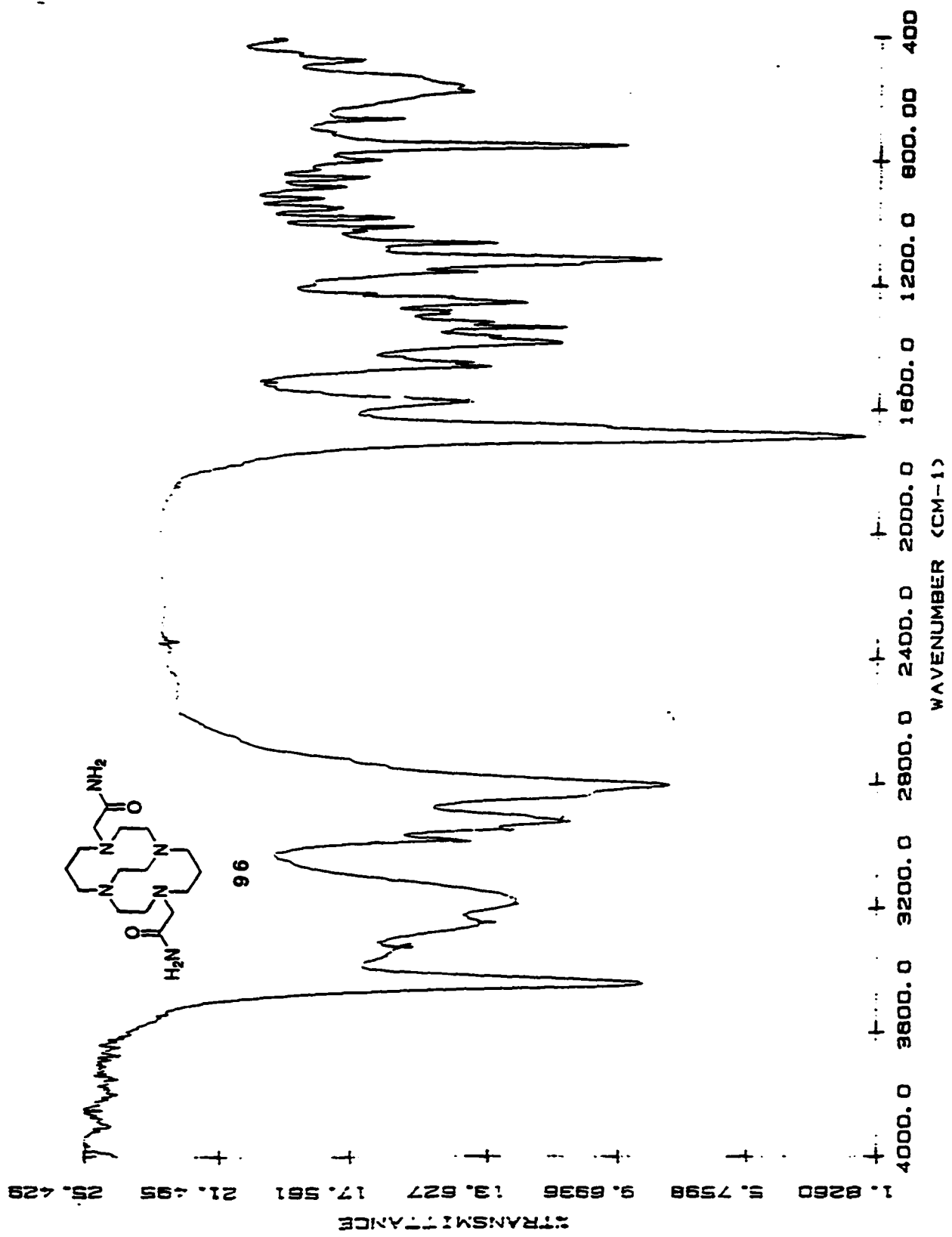

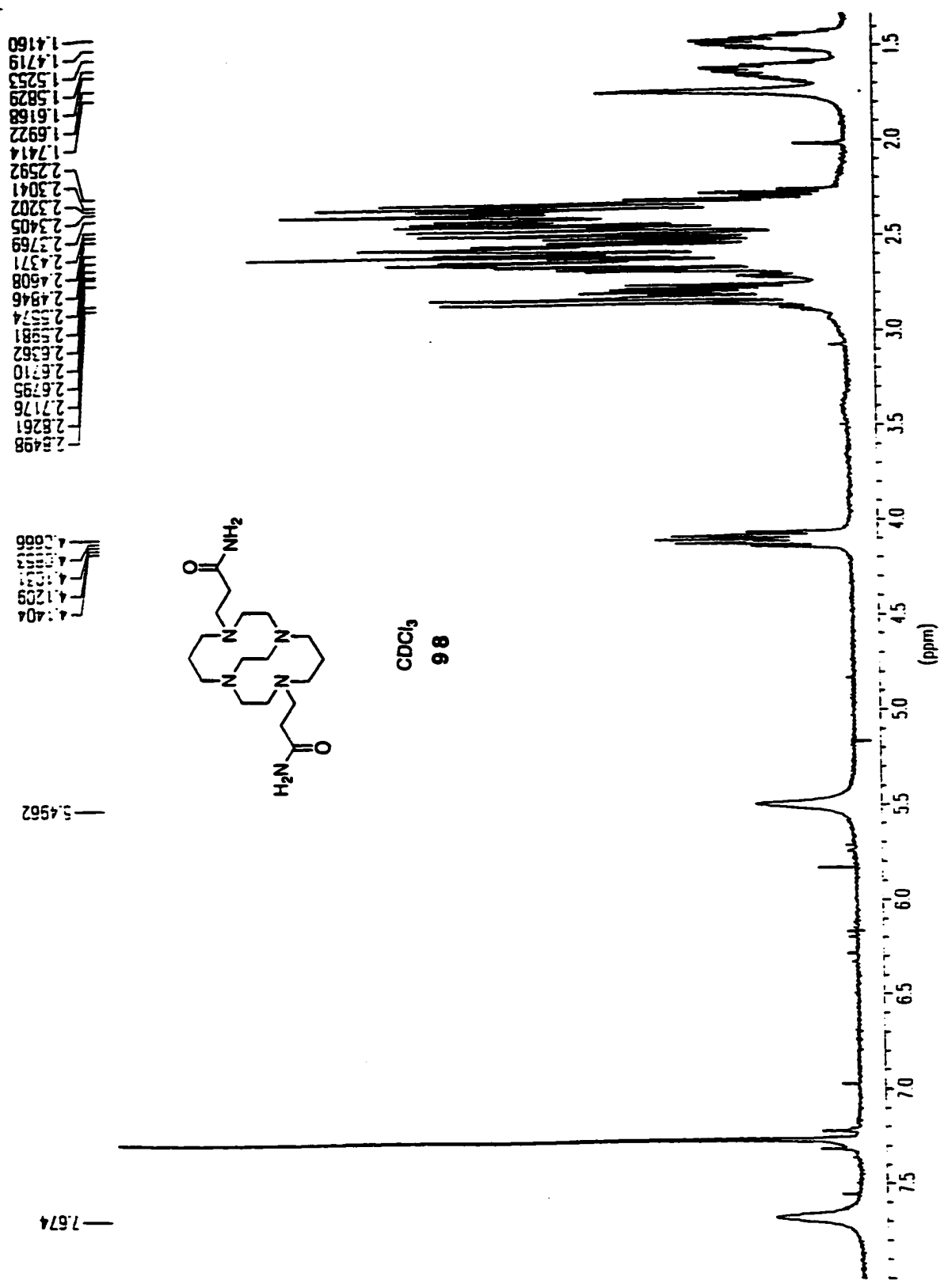

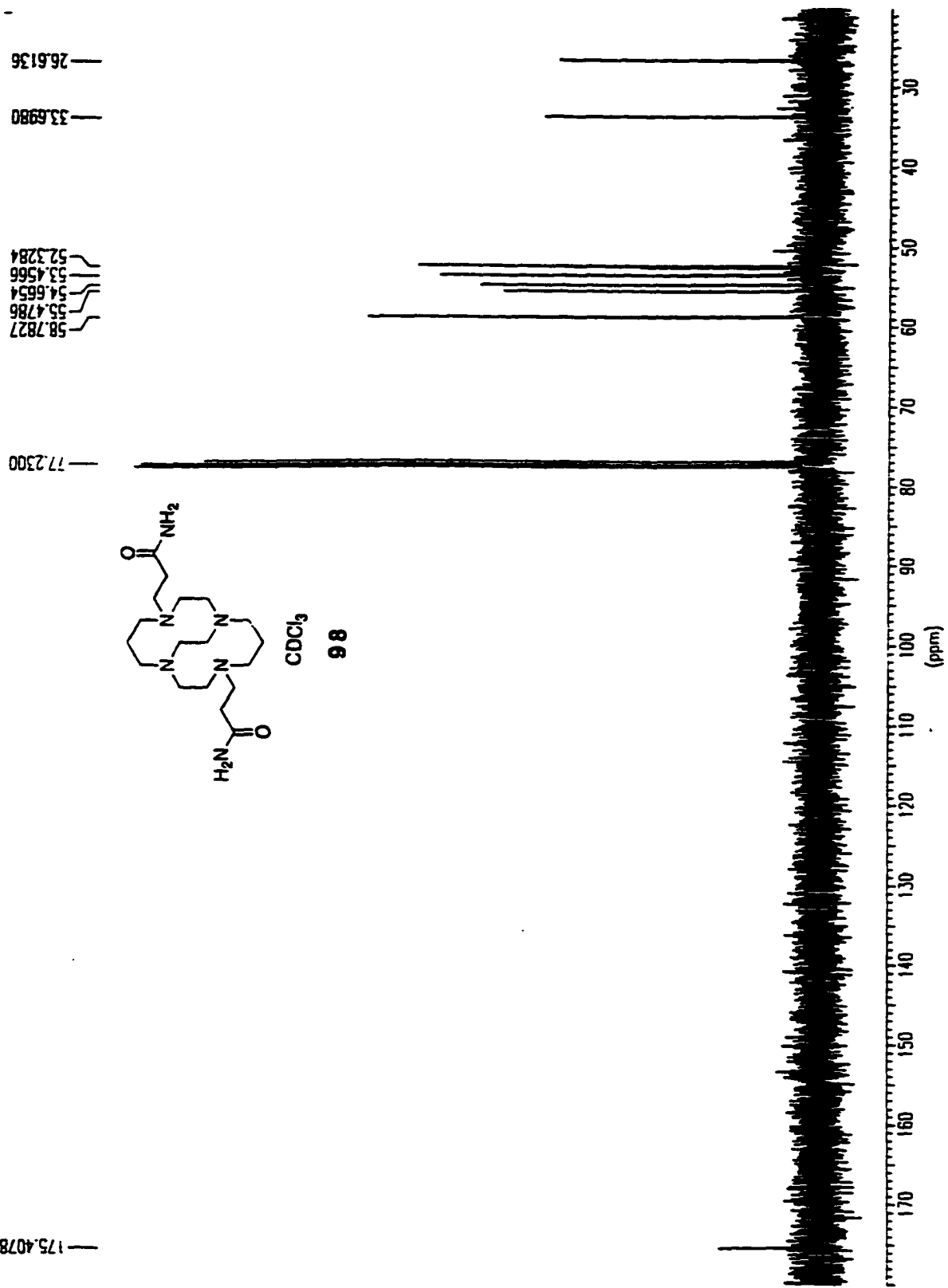

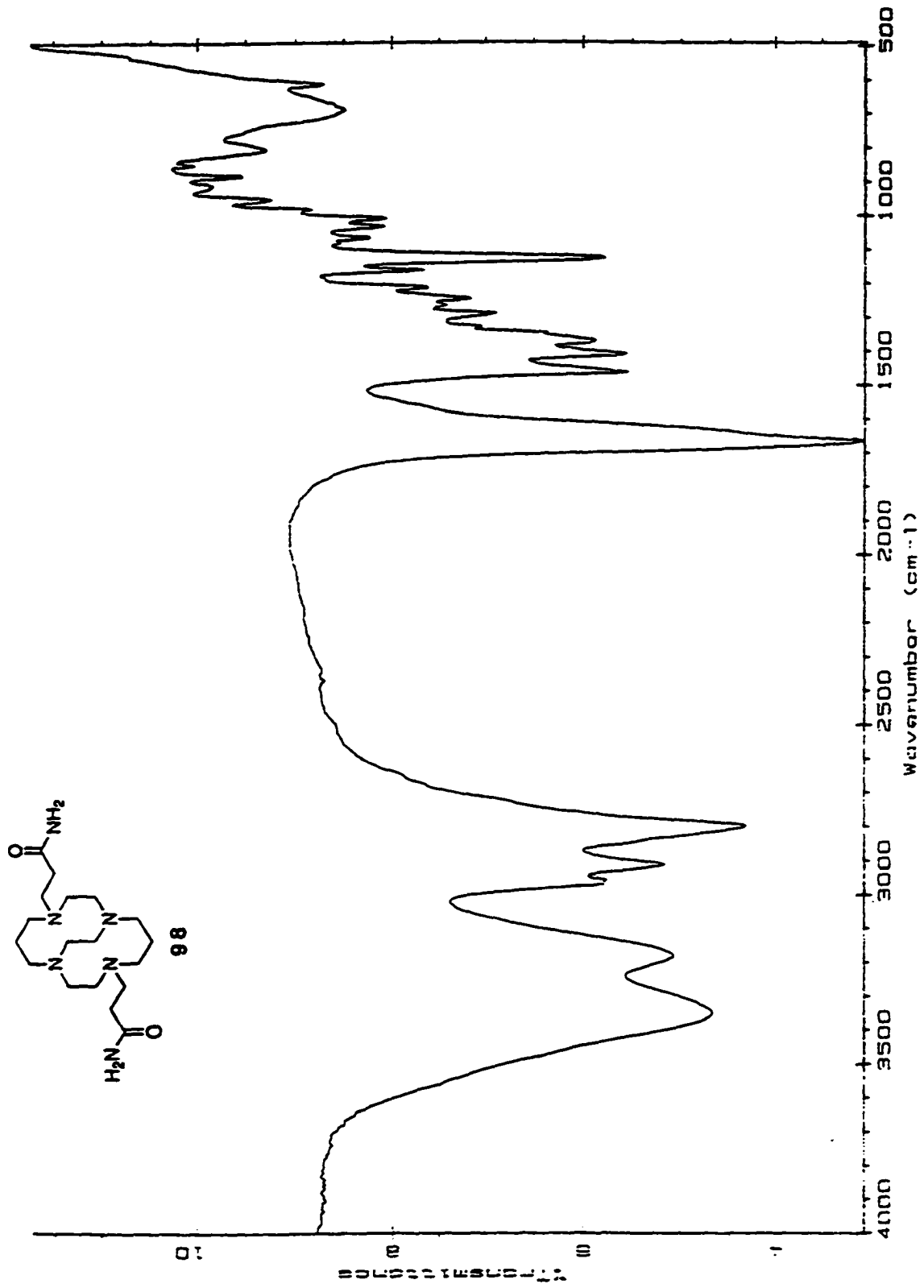

21.4926
 25.3315
 40.8703
 50.1599
 53.3028
 53.6398
 54.0794
 55.4567

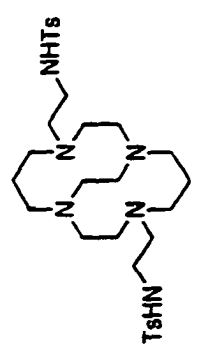

CDCl₃
 107

126.9893
 129.5607
 138.2203
 142.4694

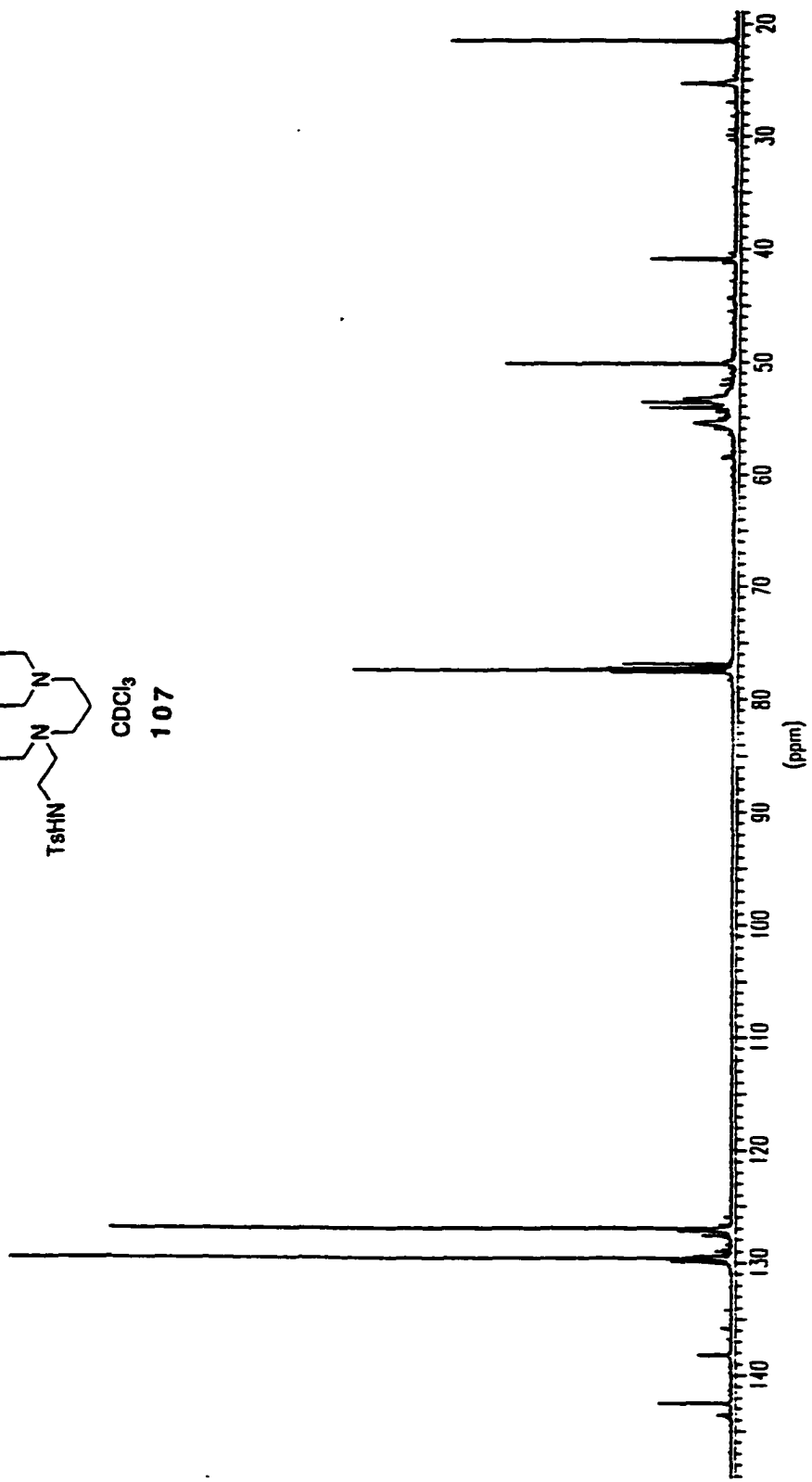

1.5456
 1.5685
 1.6778
 1.8473
 1.9685
 2.4871
 2.6371
 2.7269
 2.8362
 3.0811
 3.1489
 3.2320
 3.4006
 3.5641
 3.5828
 3.6031
 3.6218
 3.6413
 4.9140
 4.9835
 7.0266
 7.0529
 8.6282
 8.6206
 8.2206
 8.2130
 8.1943
 8.1867

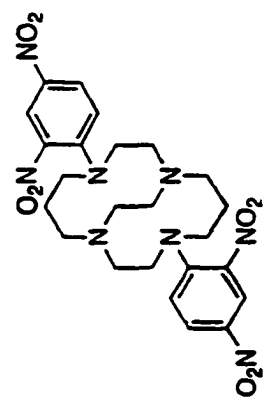

CDCl₃
 118

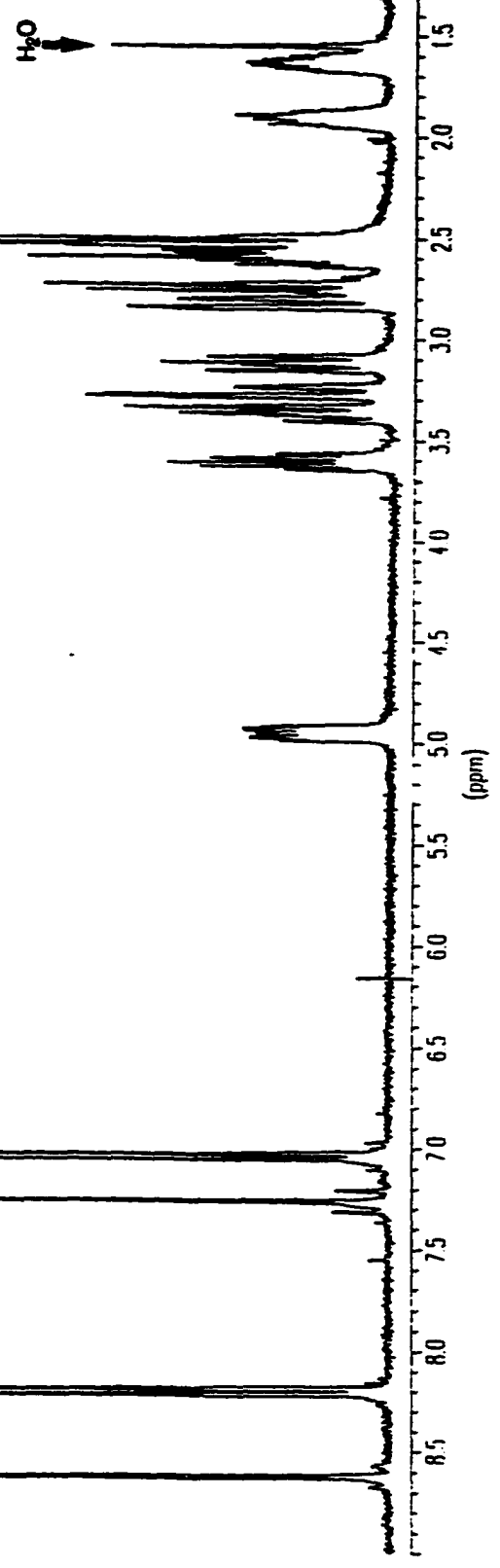

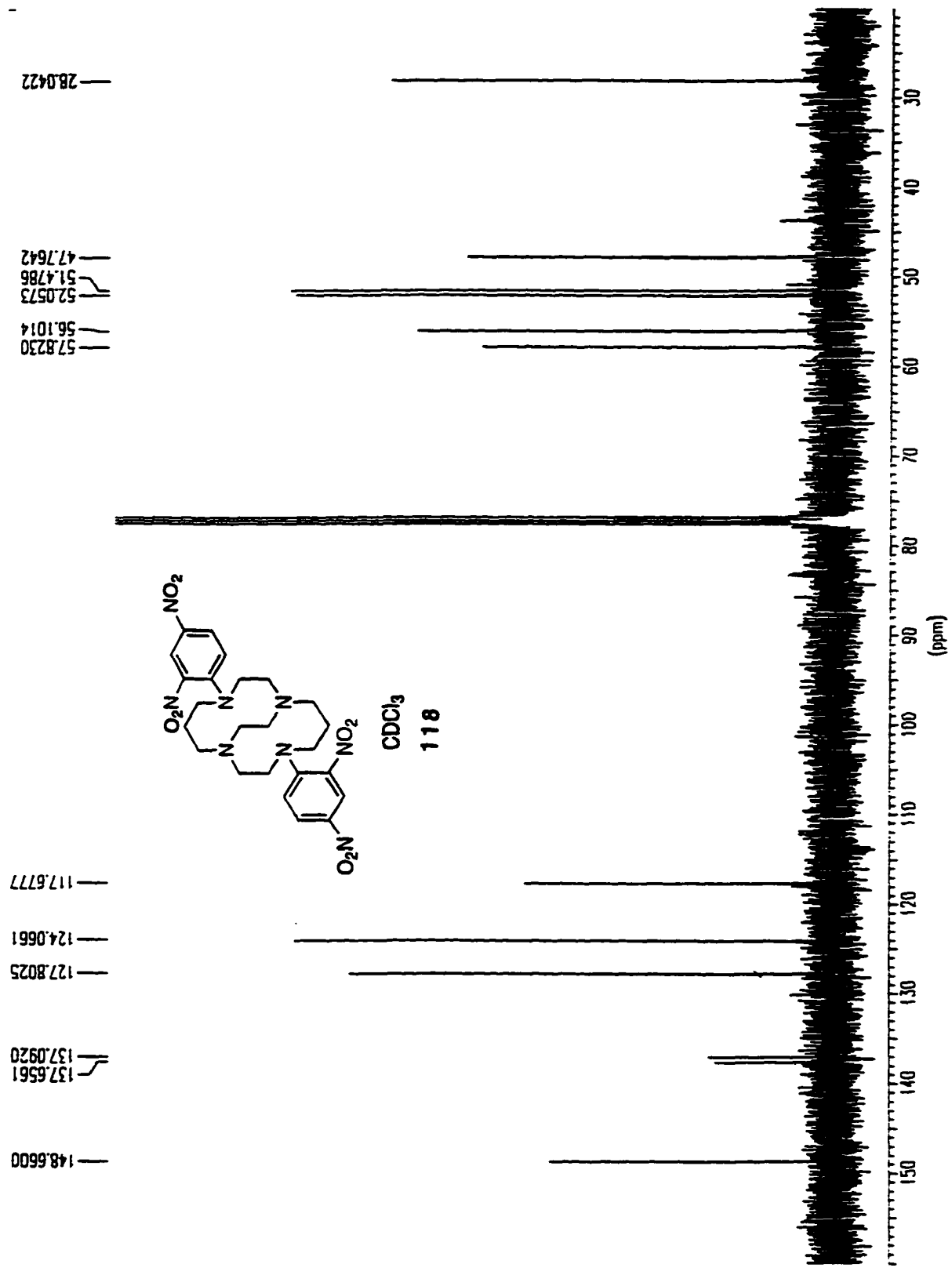

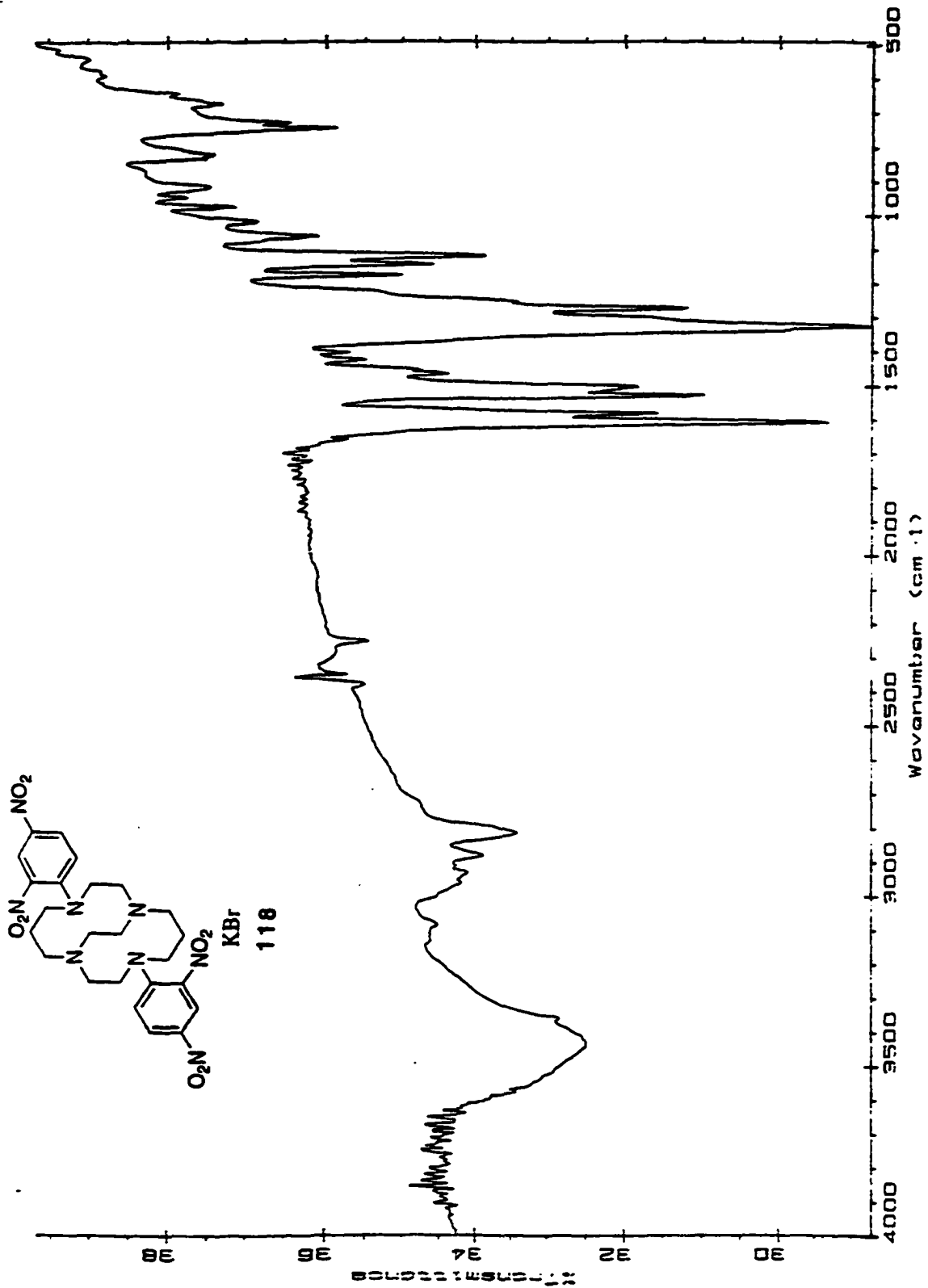

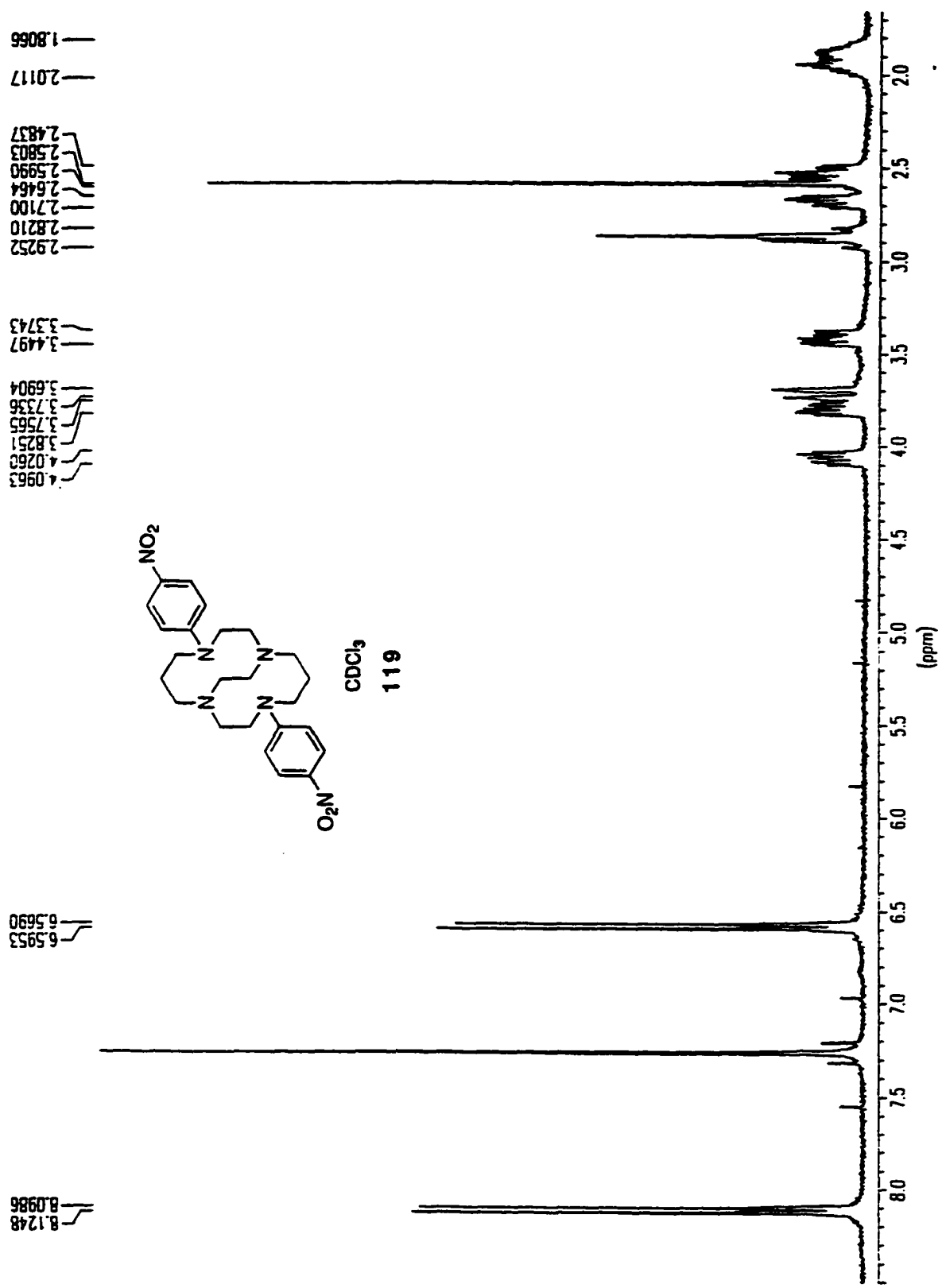

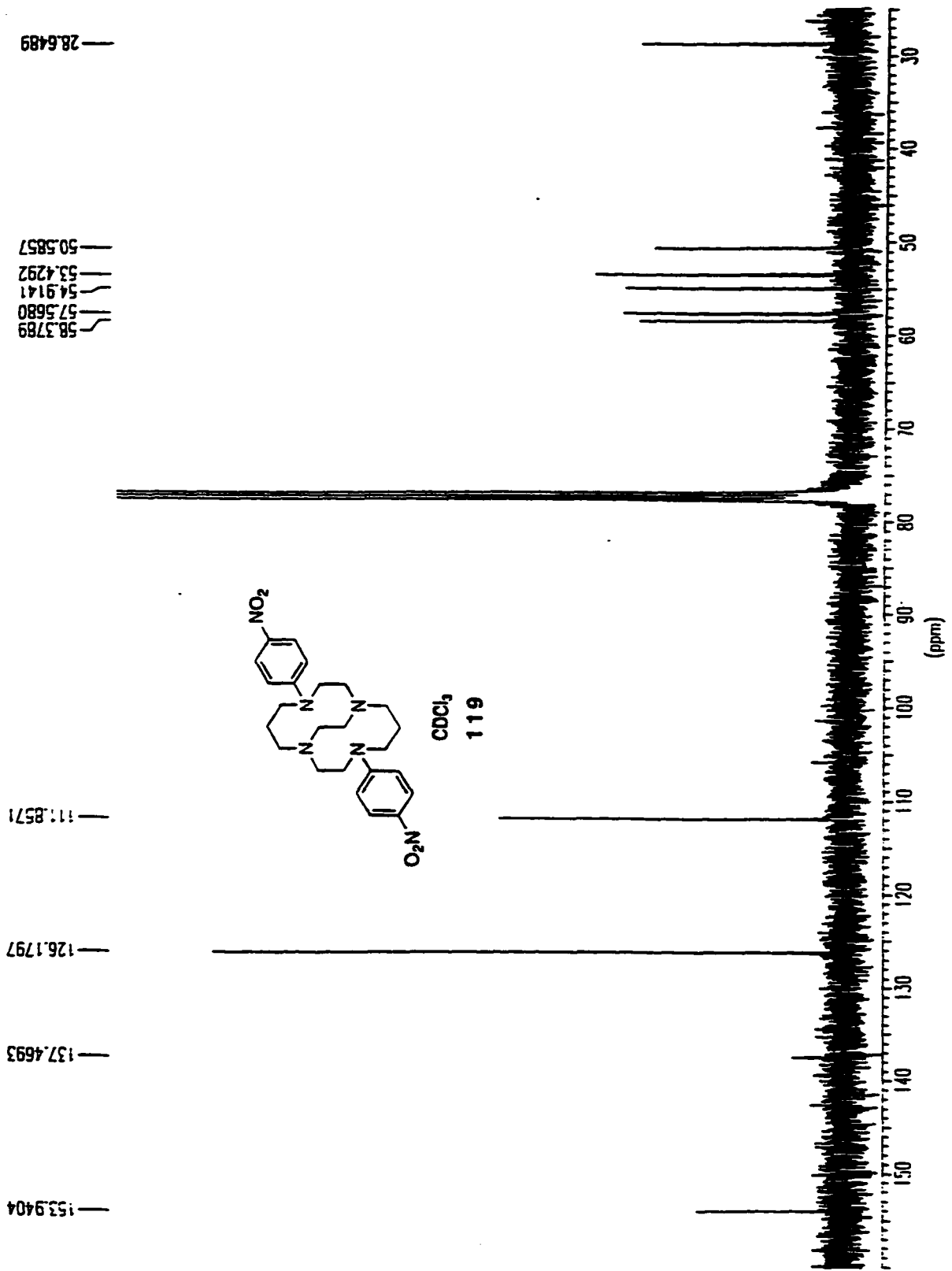

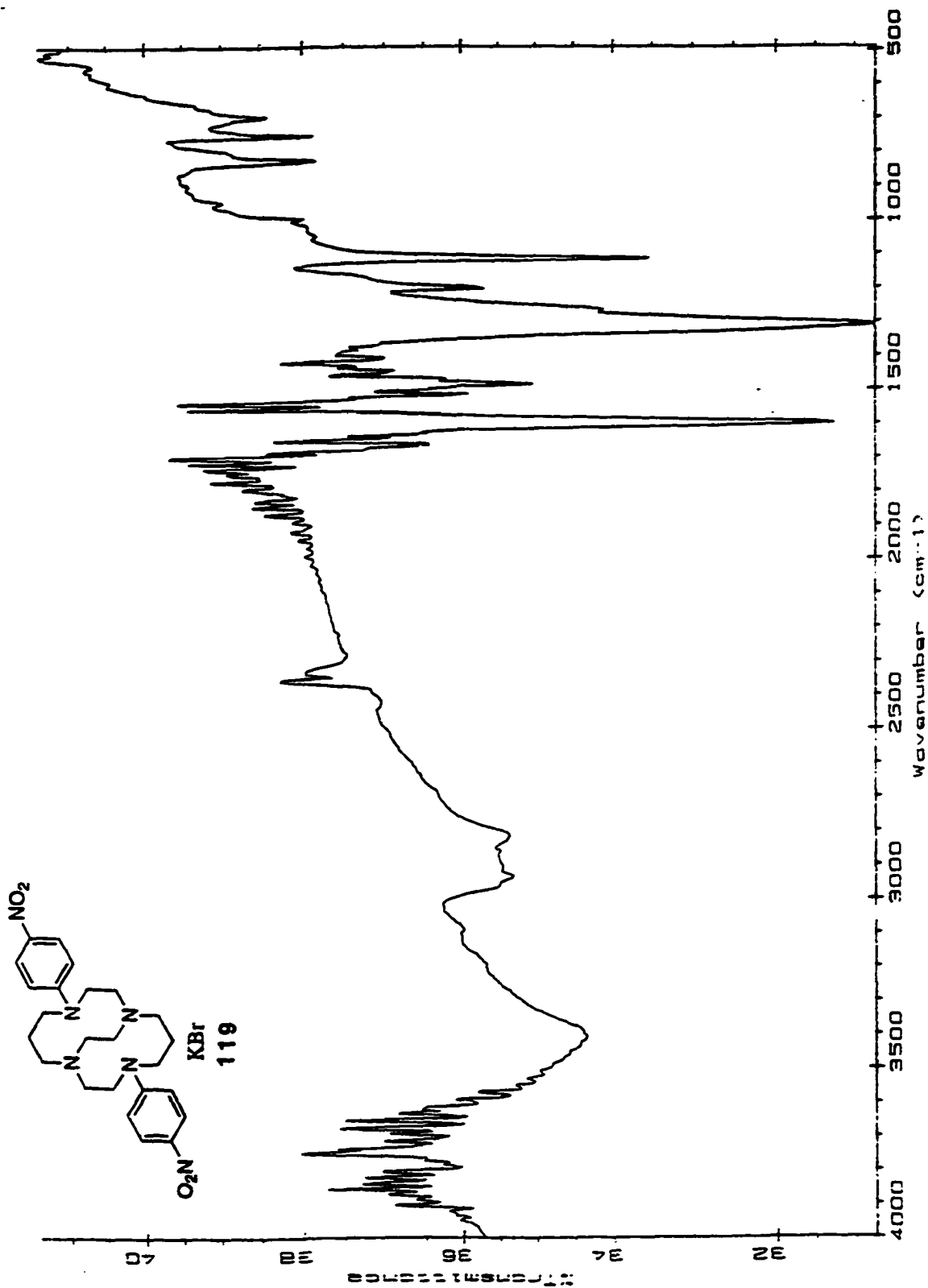

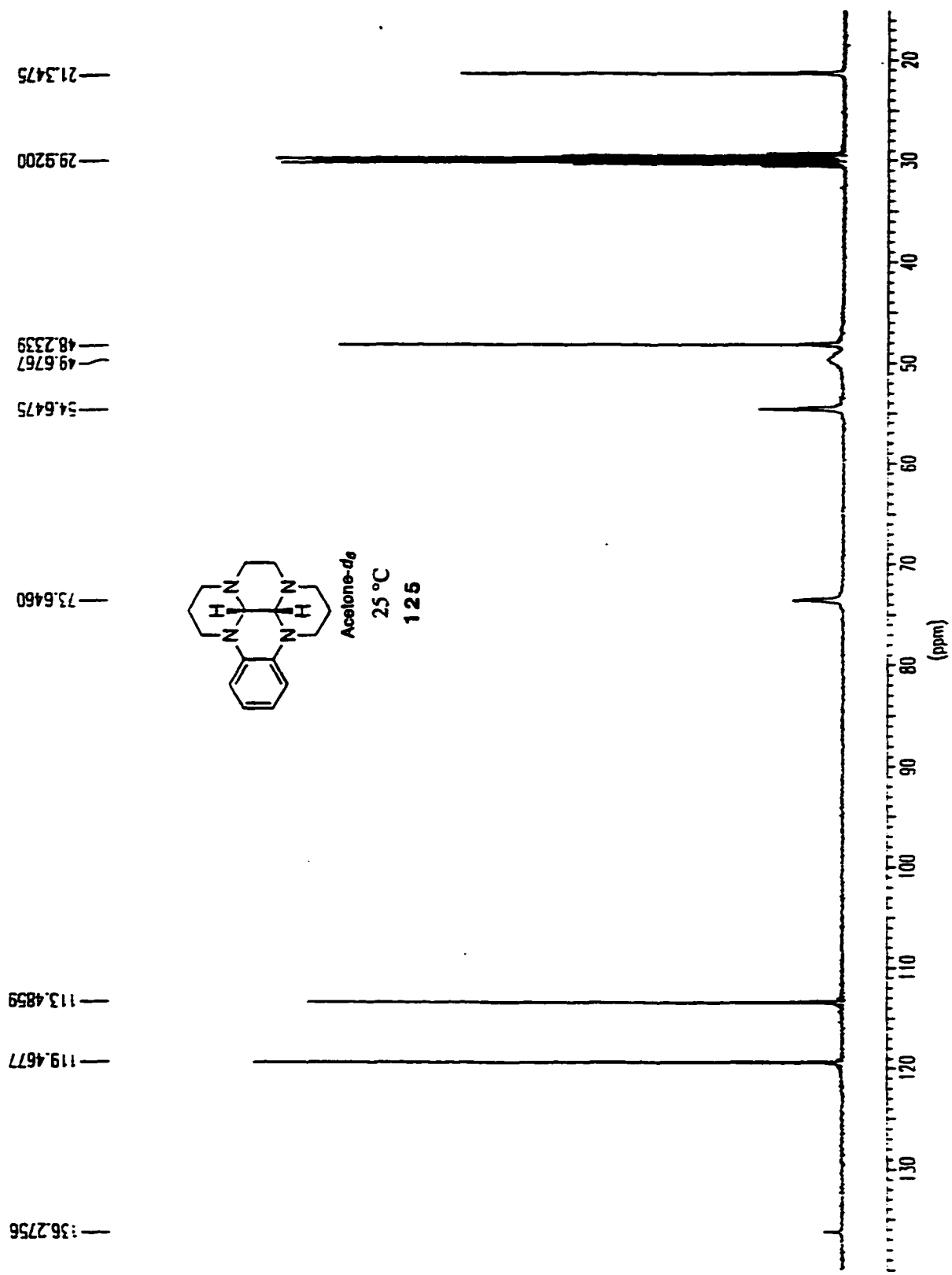

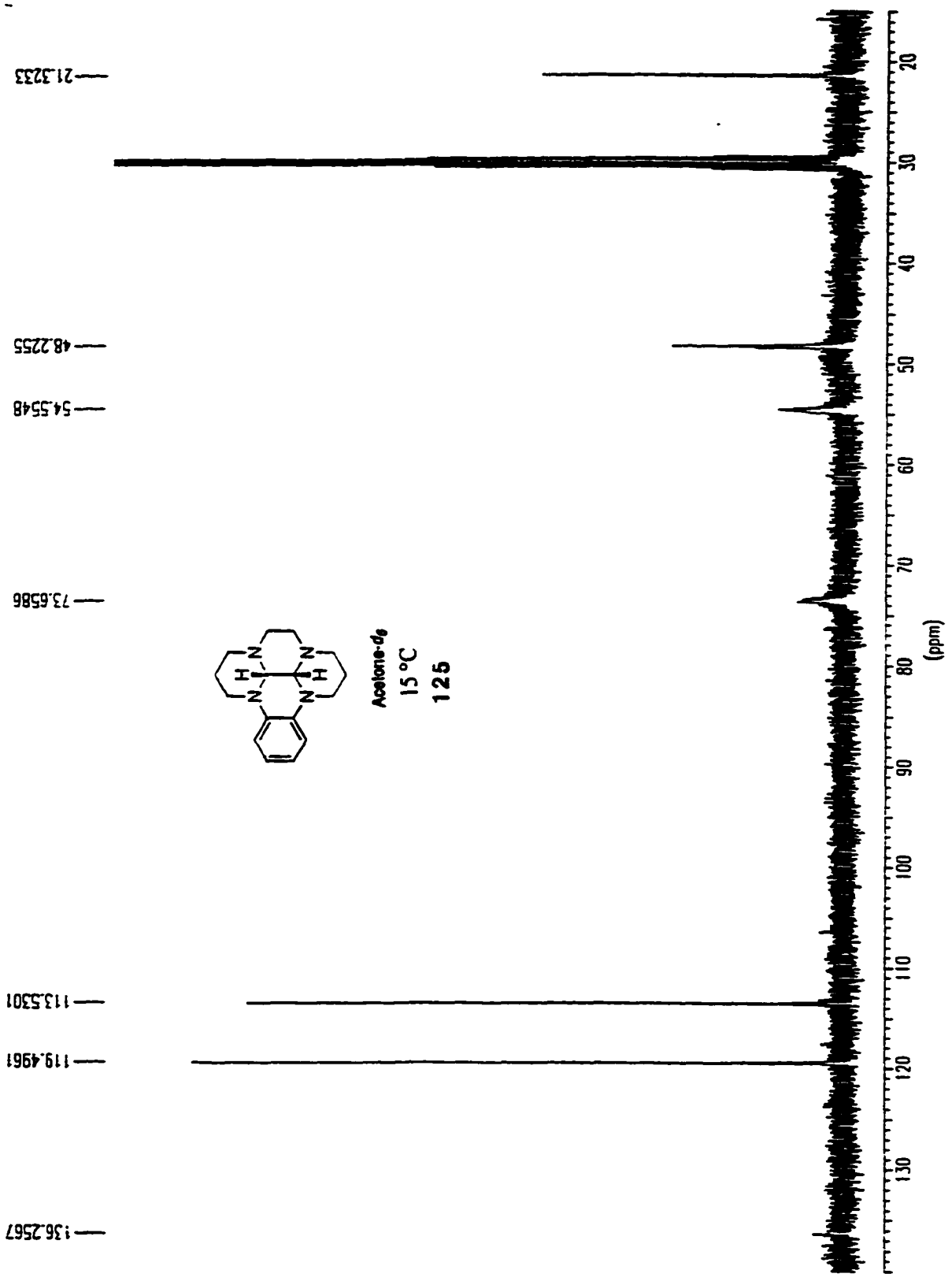

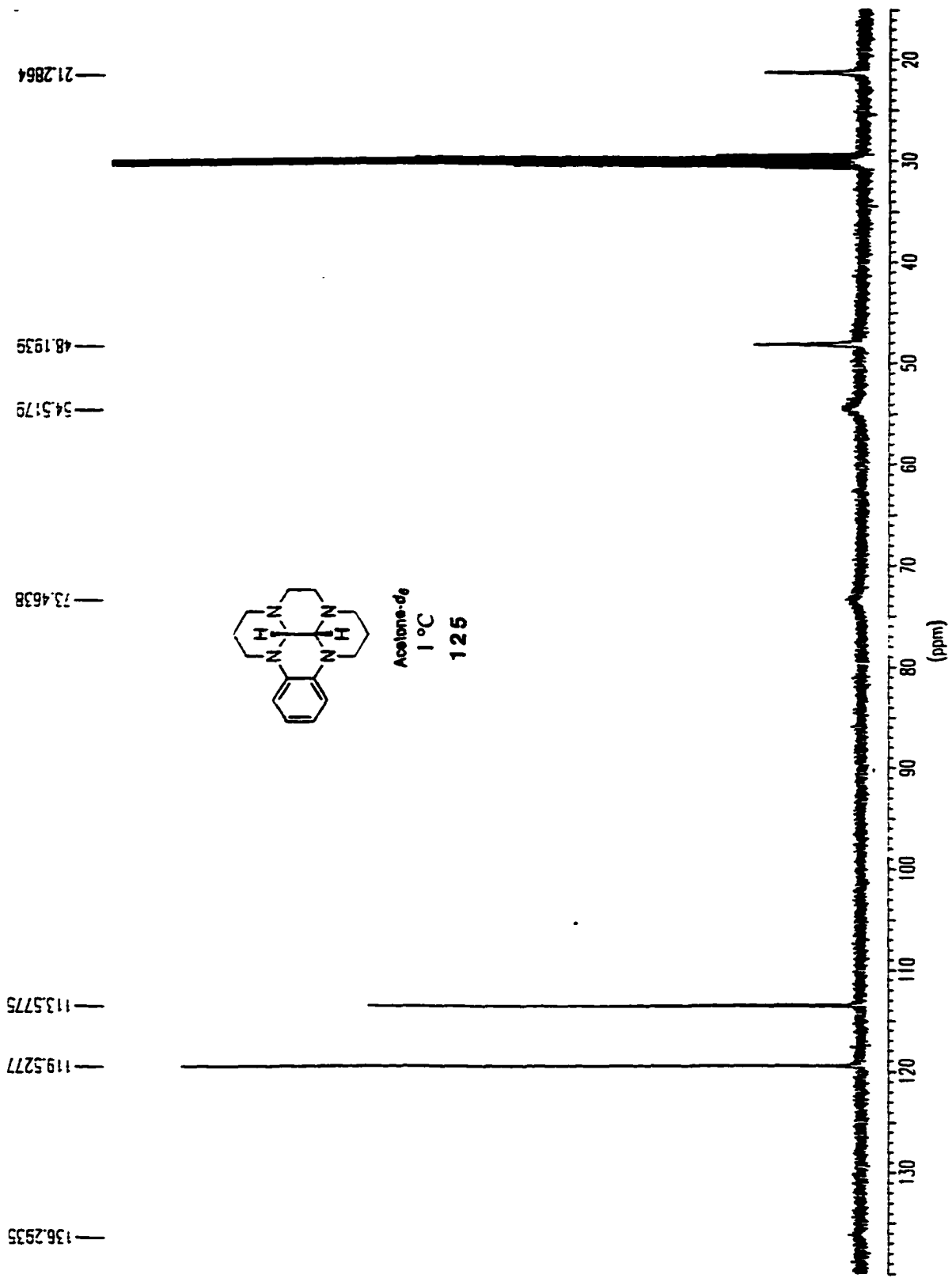

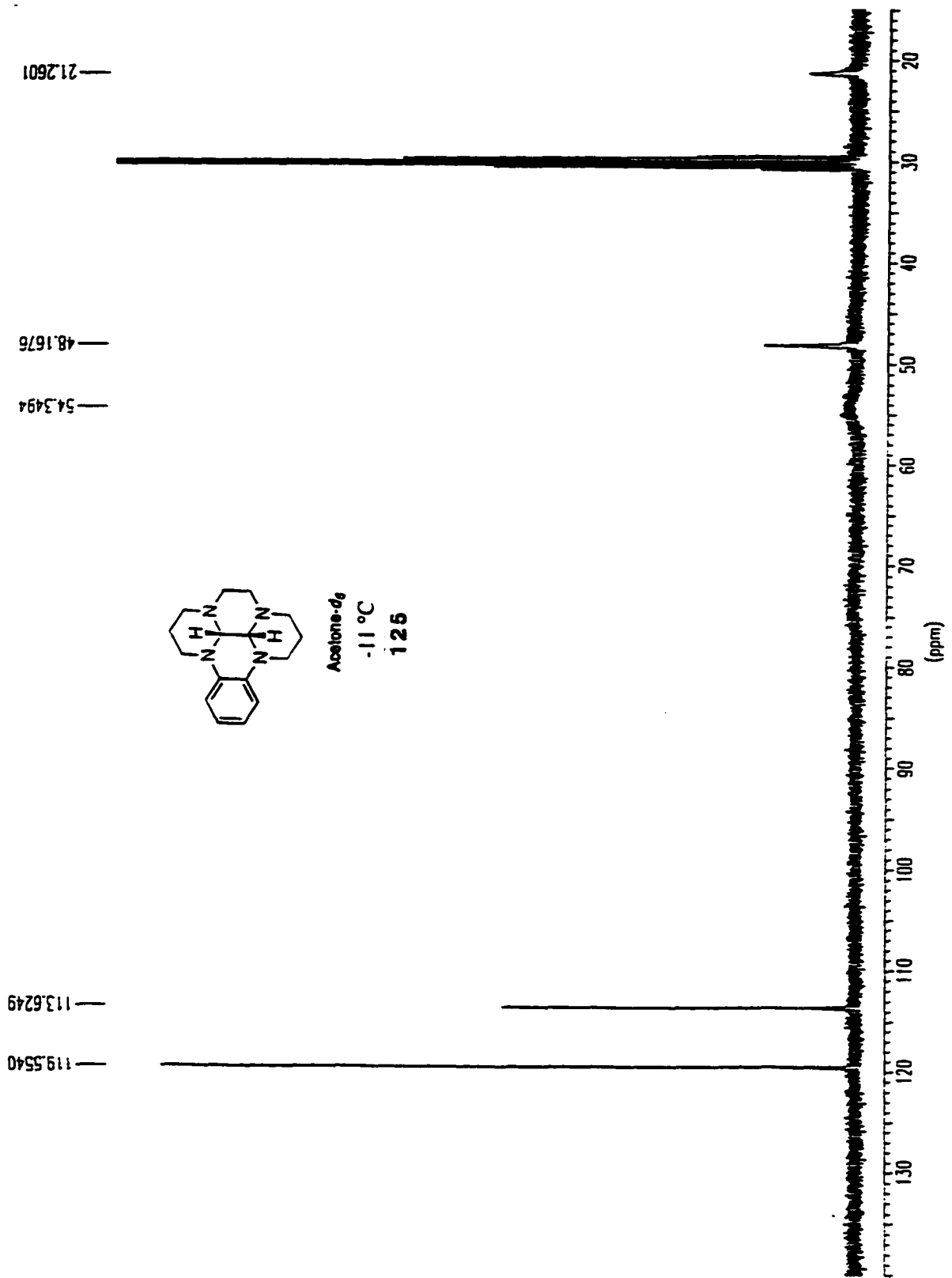

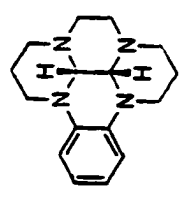
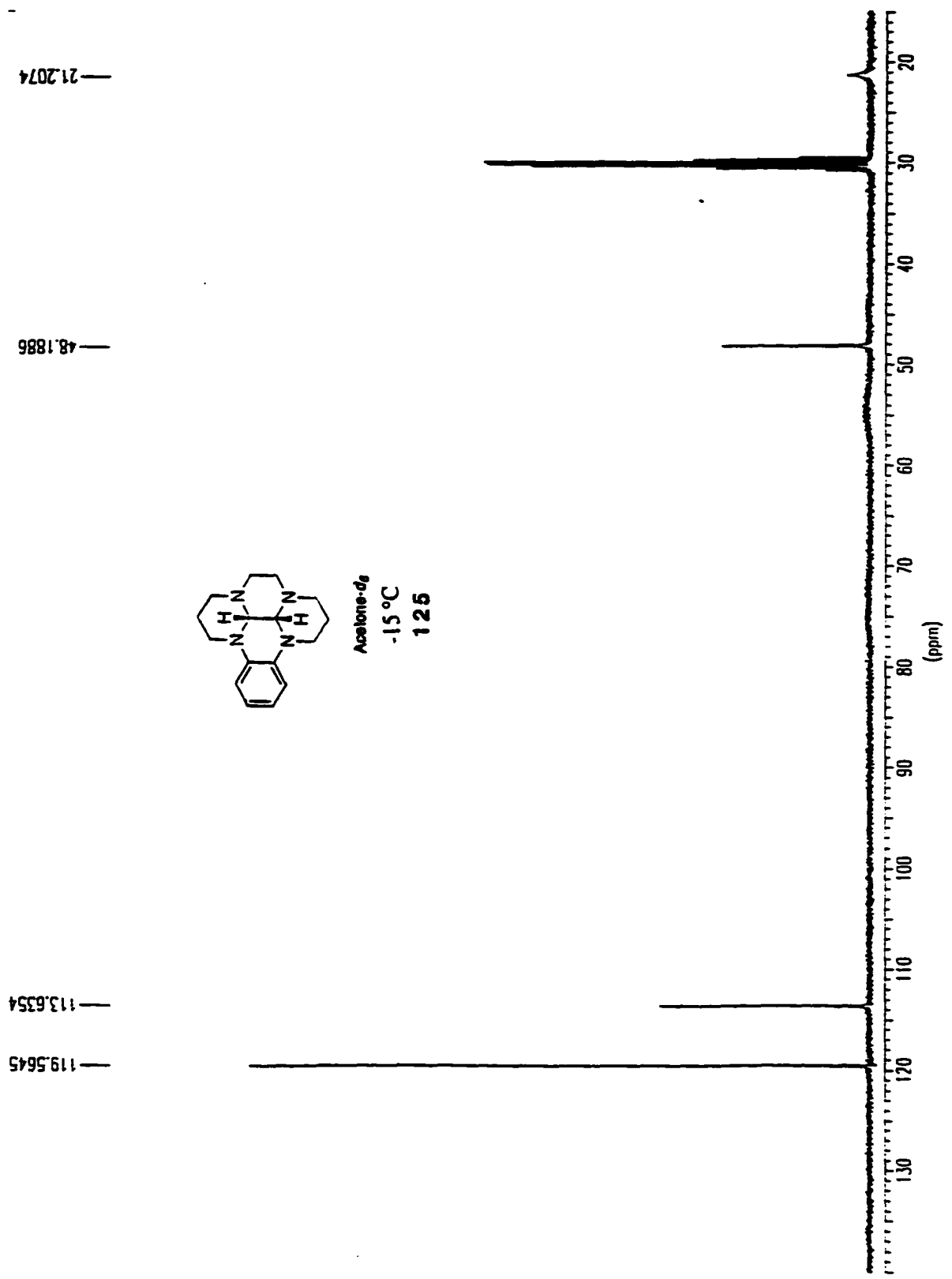

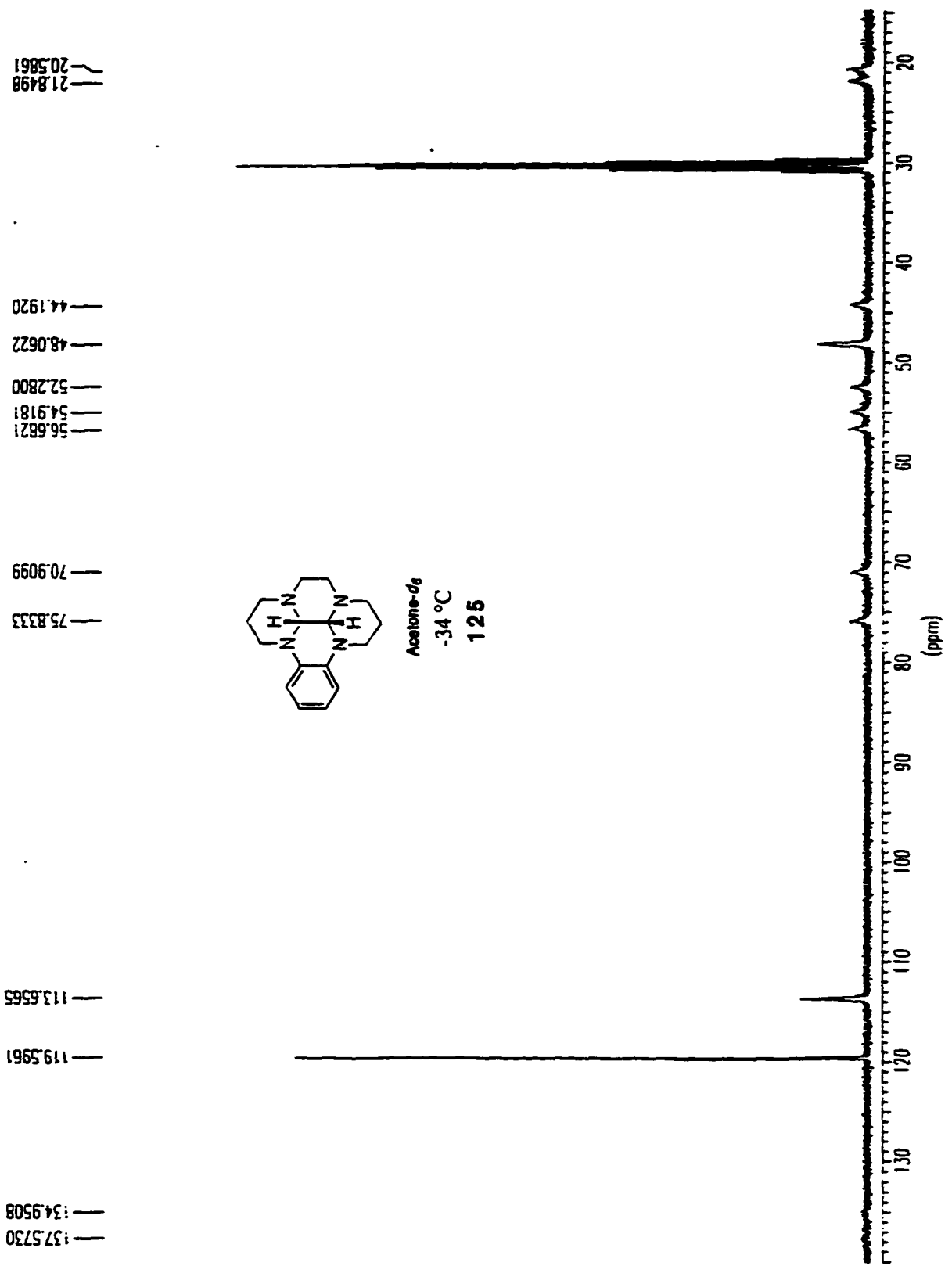

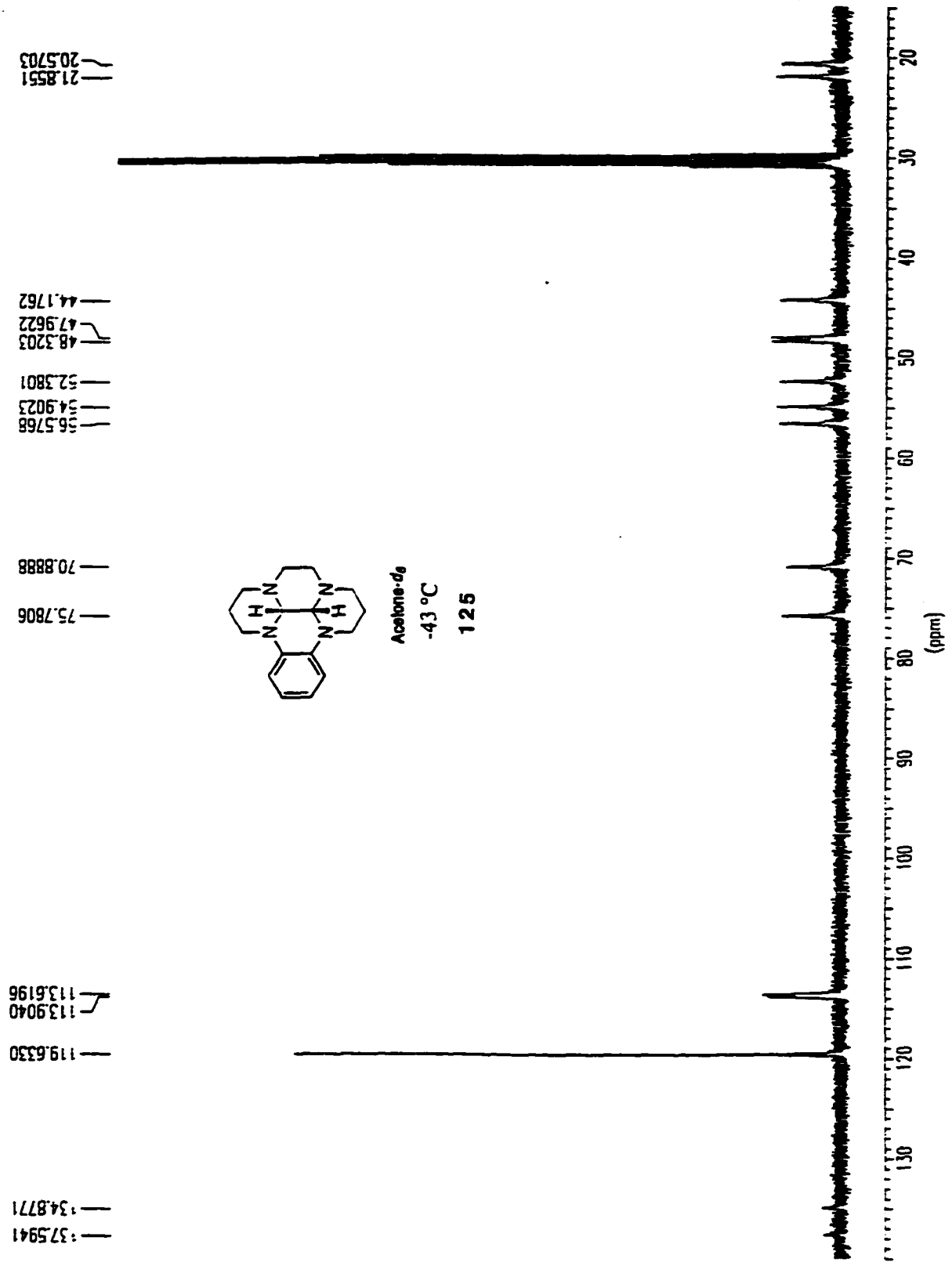

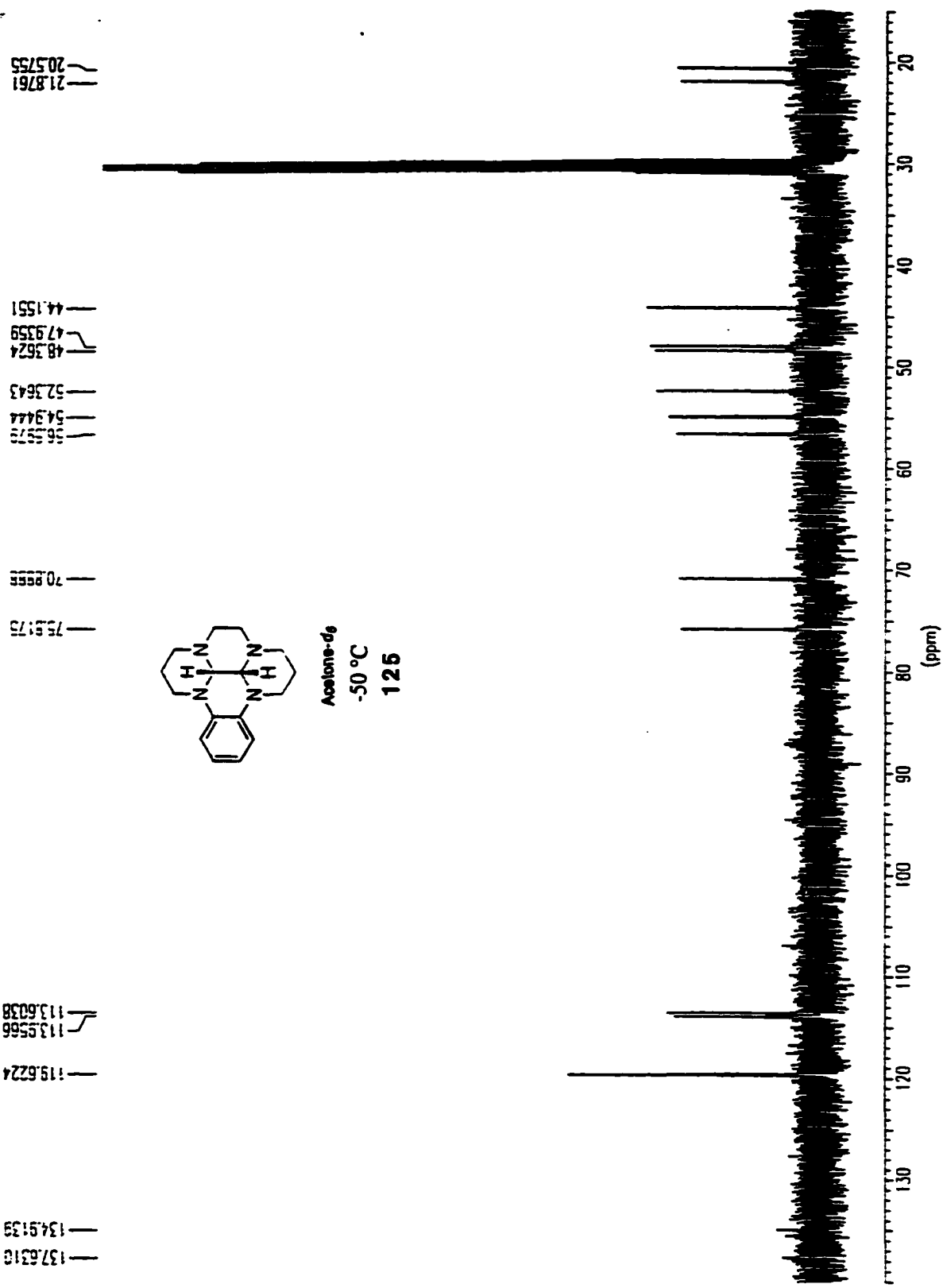

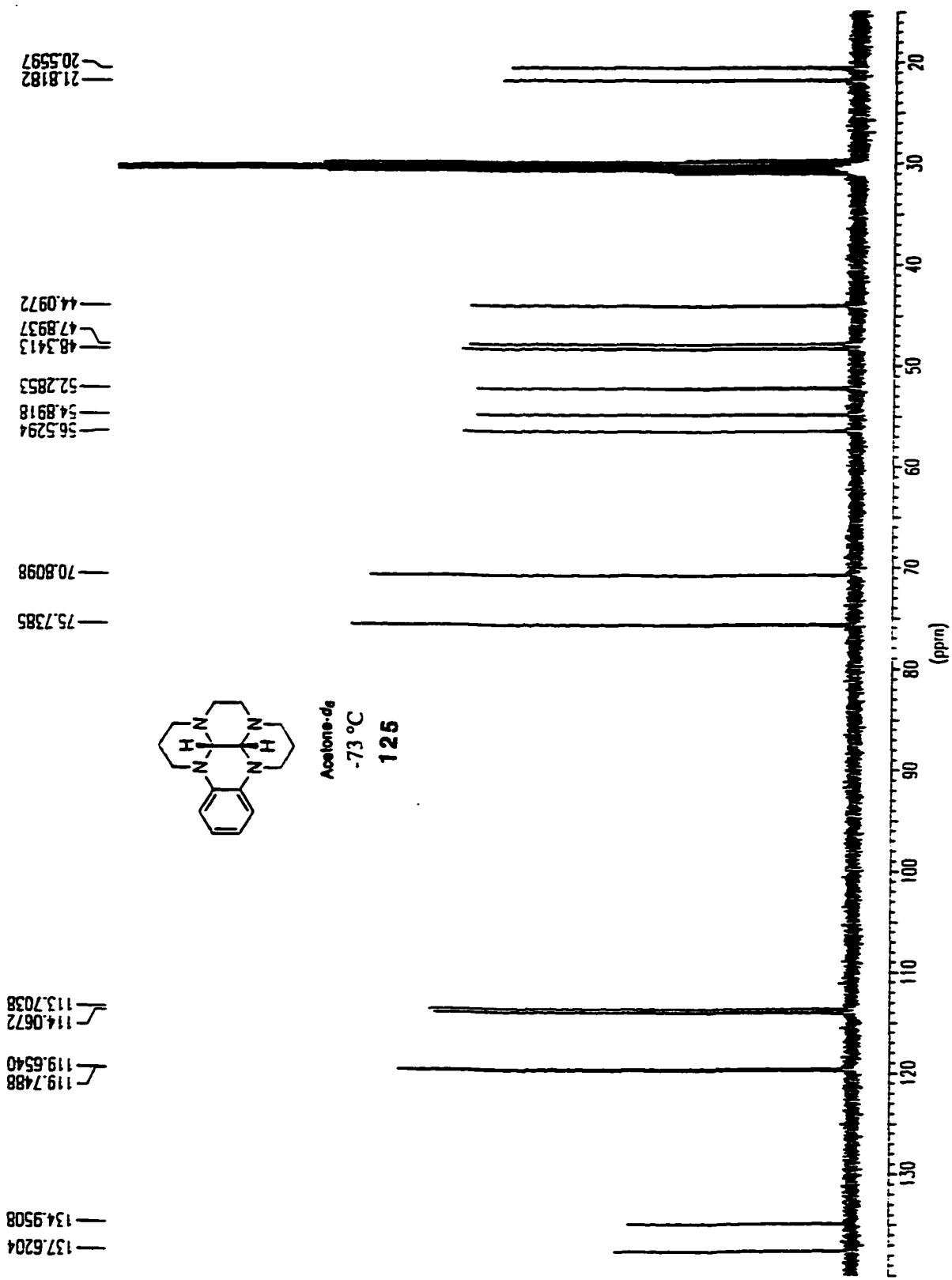

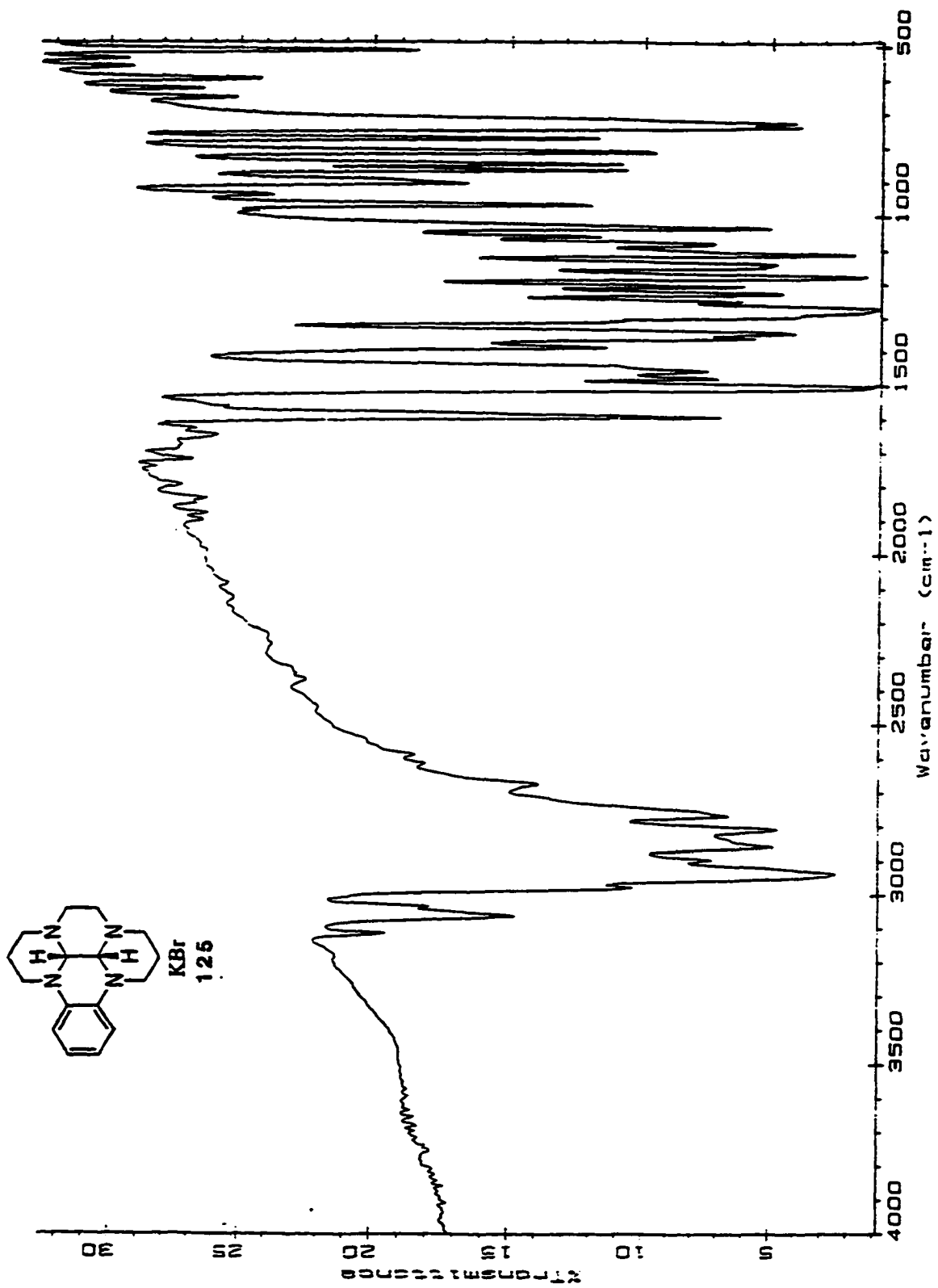

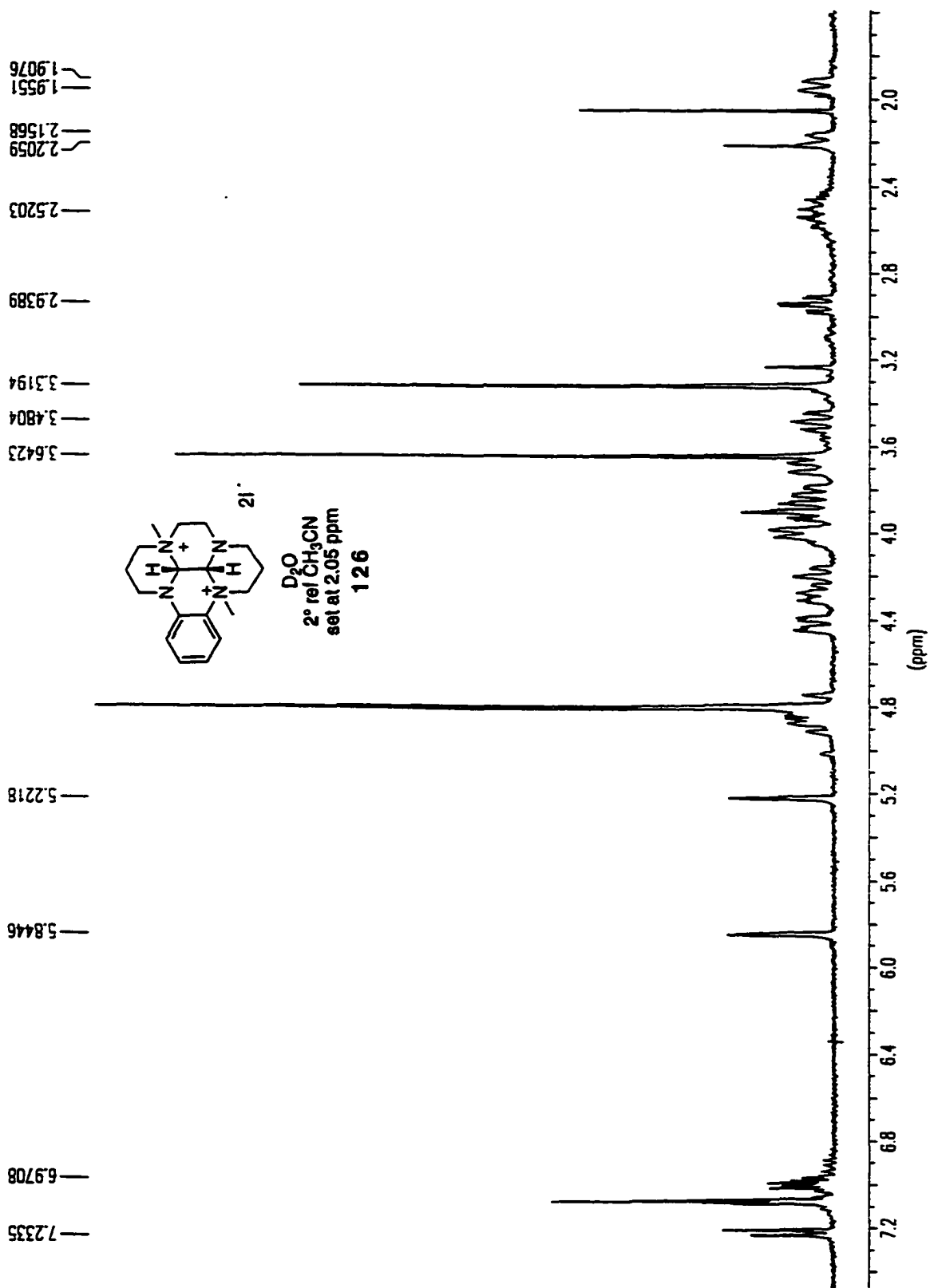

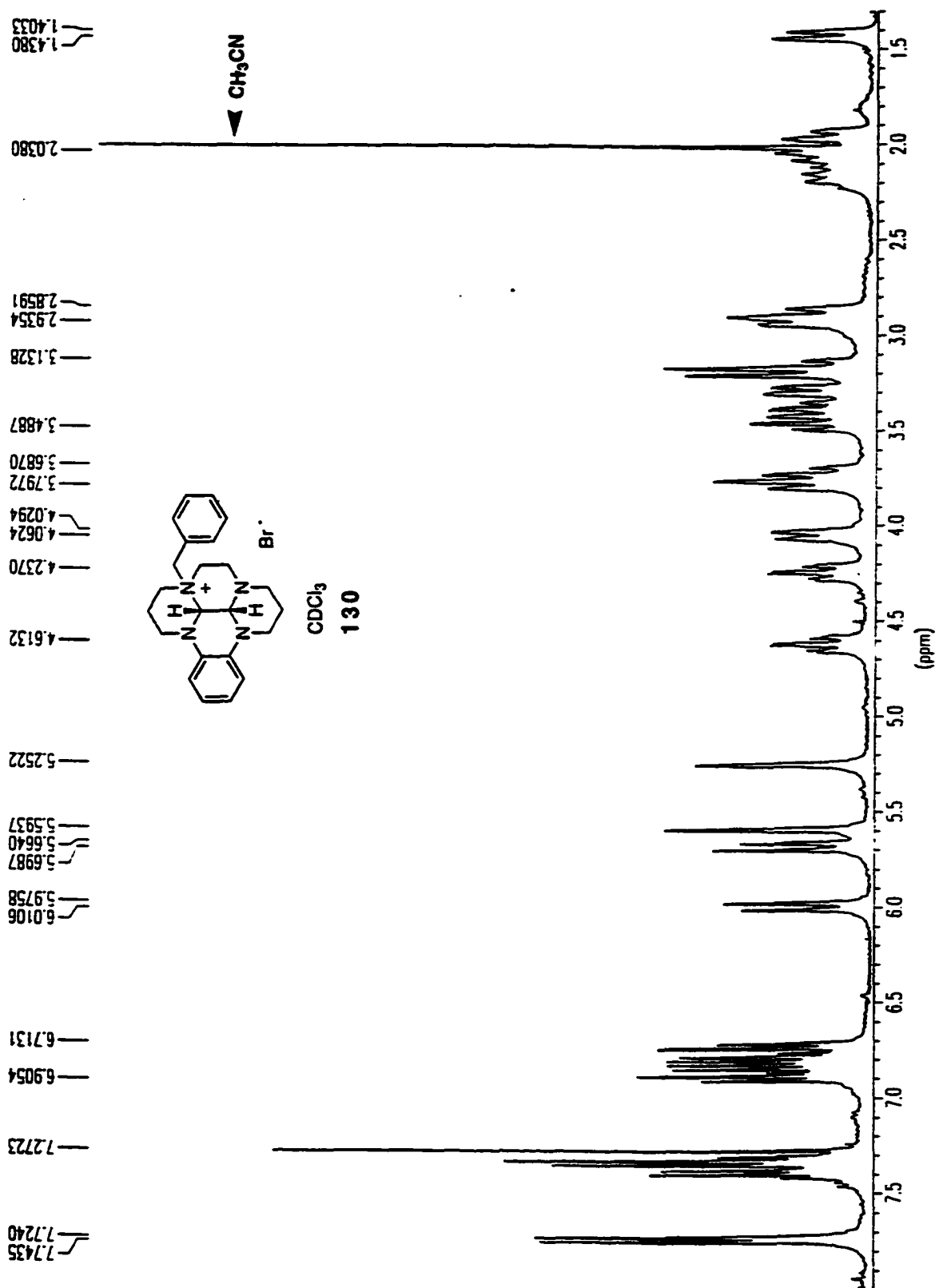

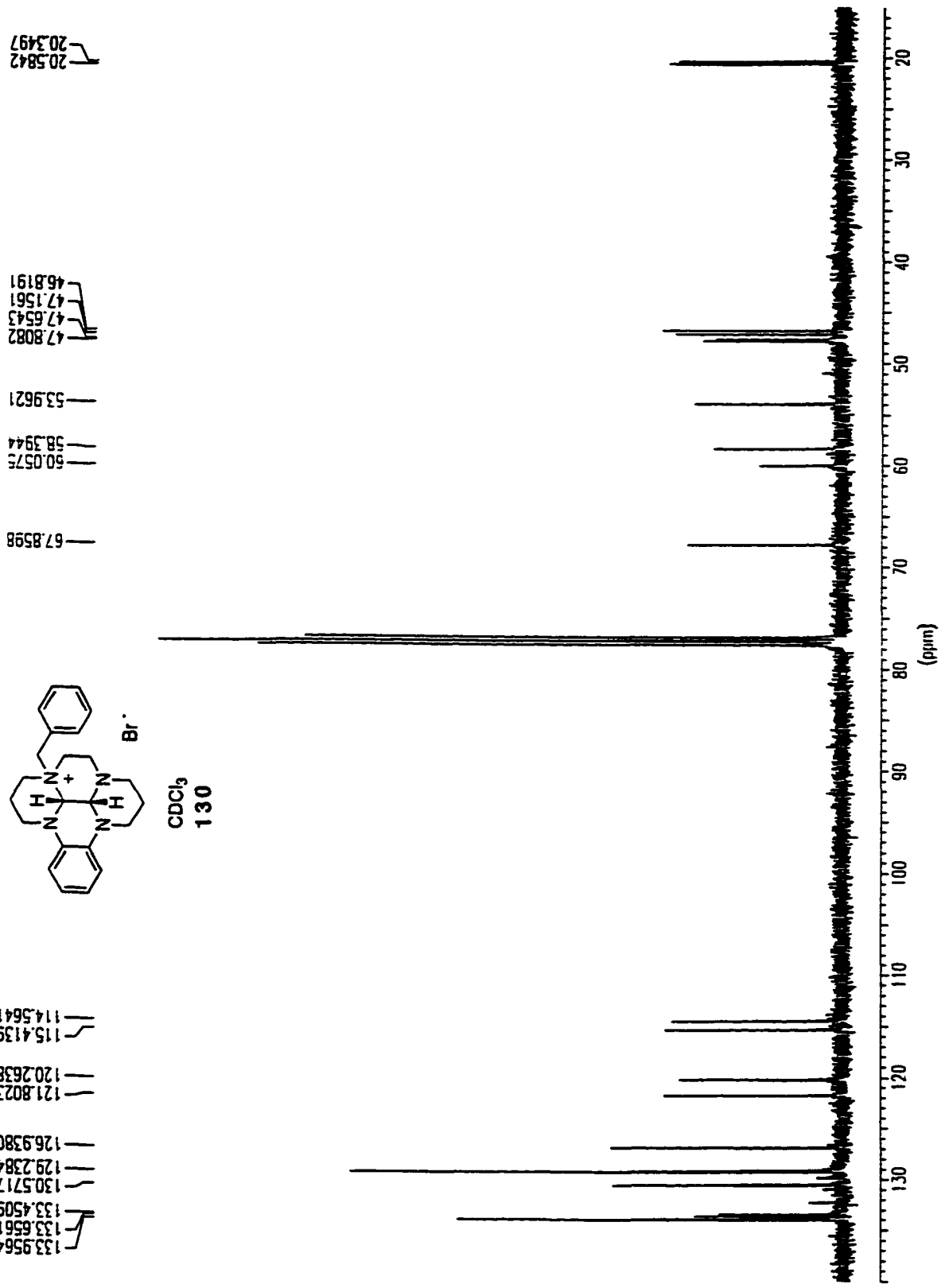

333

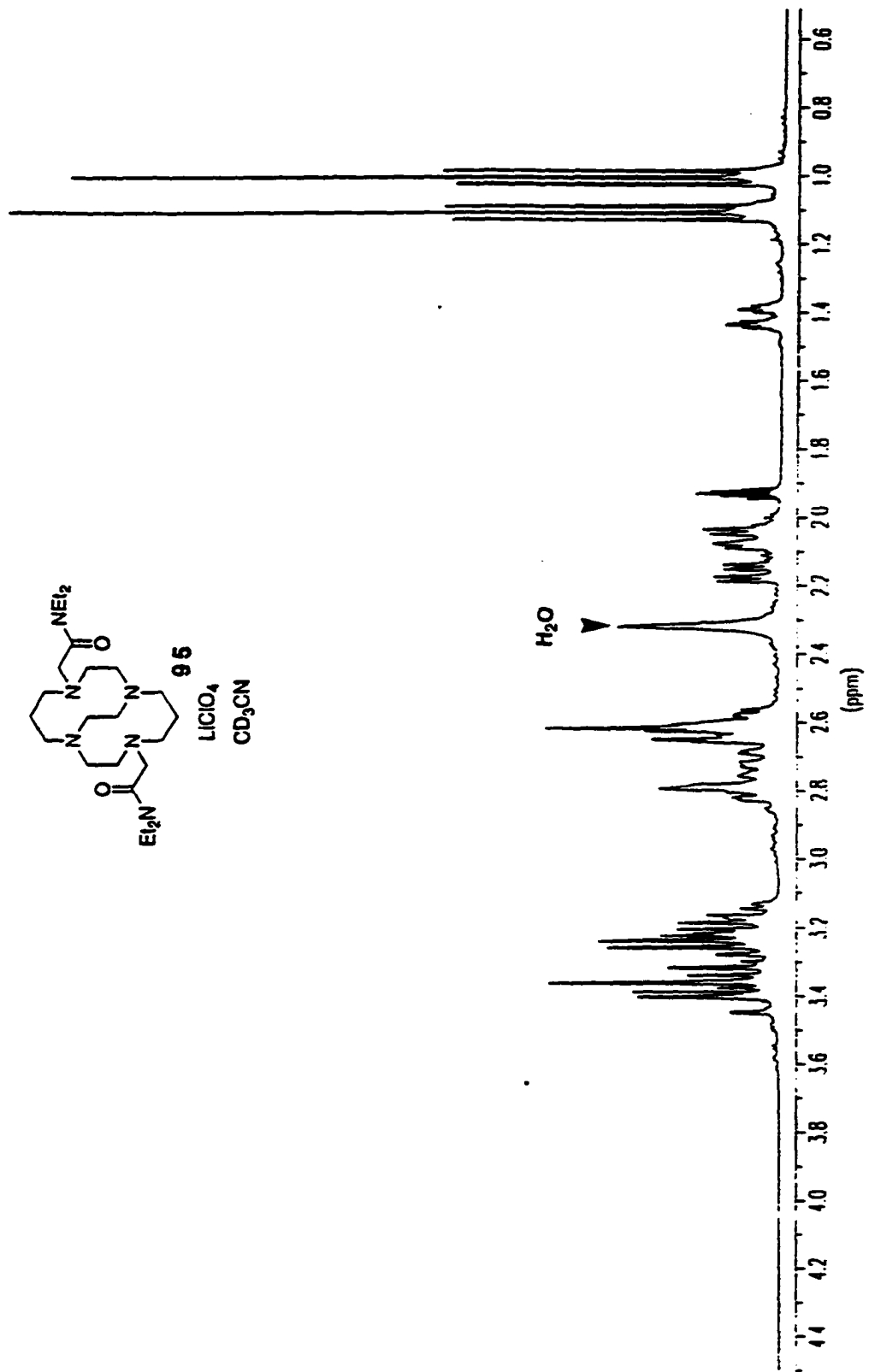

13.5439
14.6884
26.1472
41.7275
42.4437
53.1021
59.1755
59.7512
61.0783
62.3562

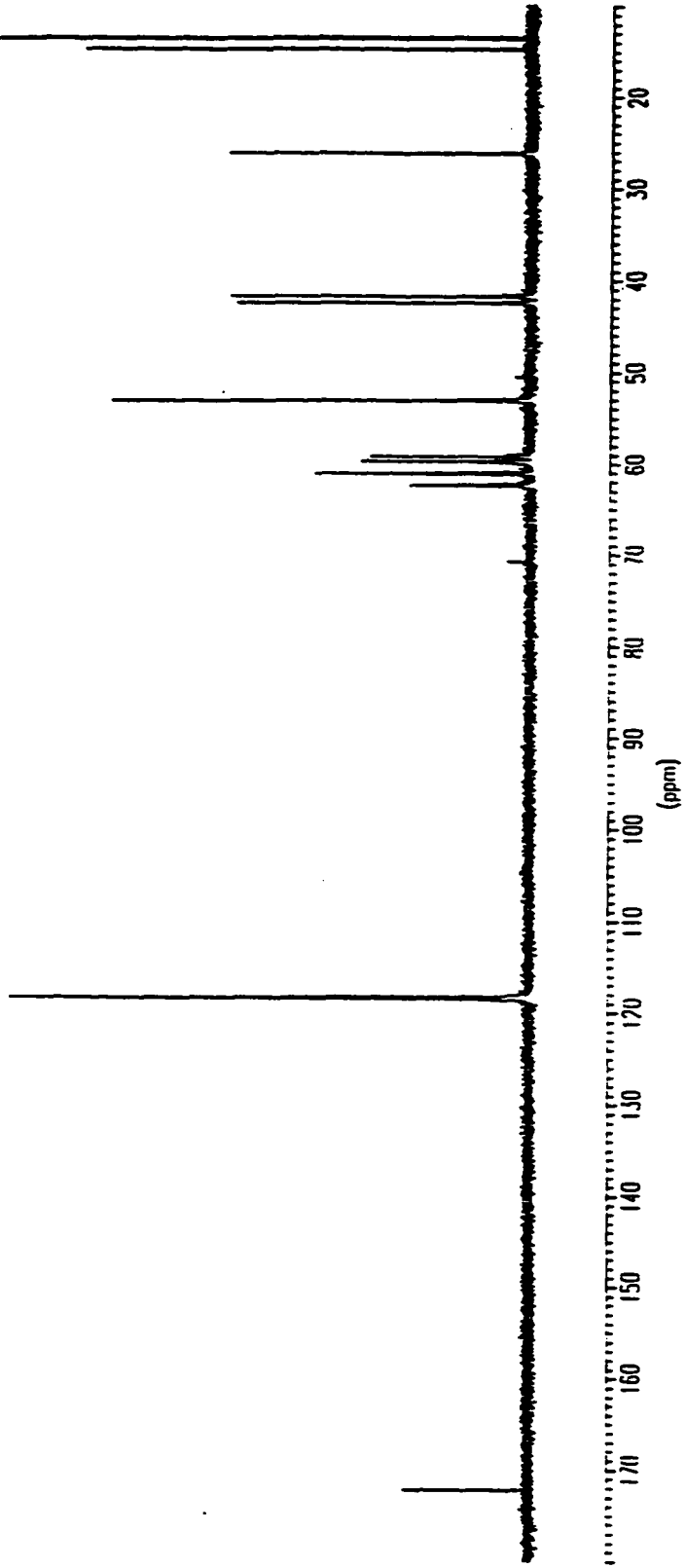
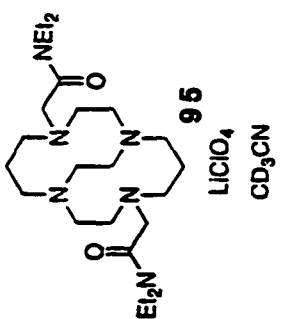

336

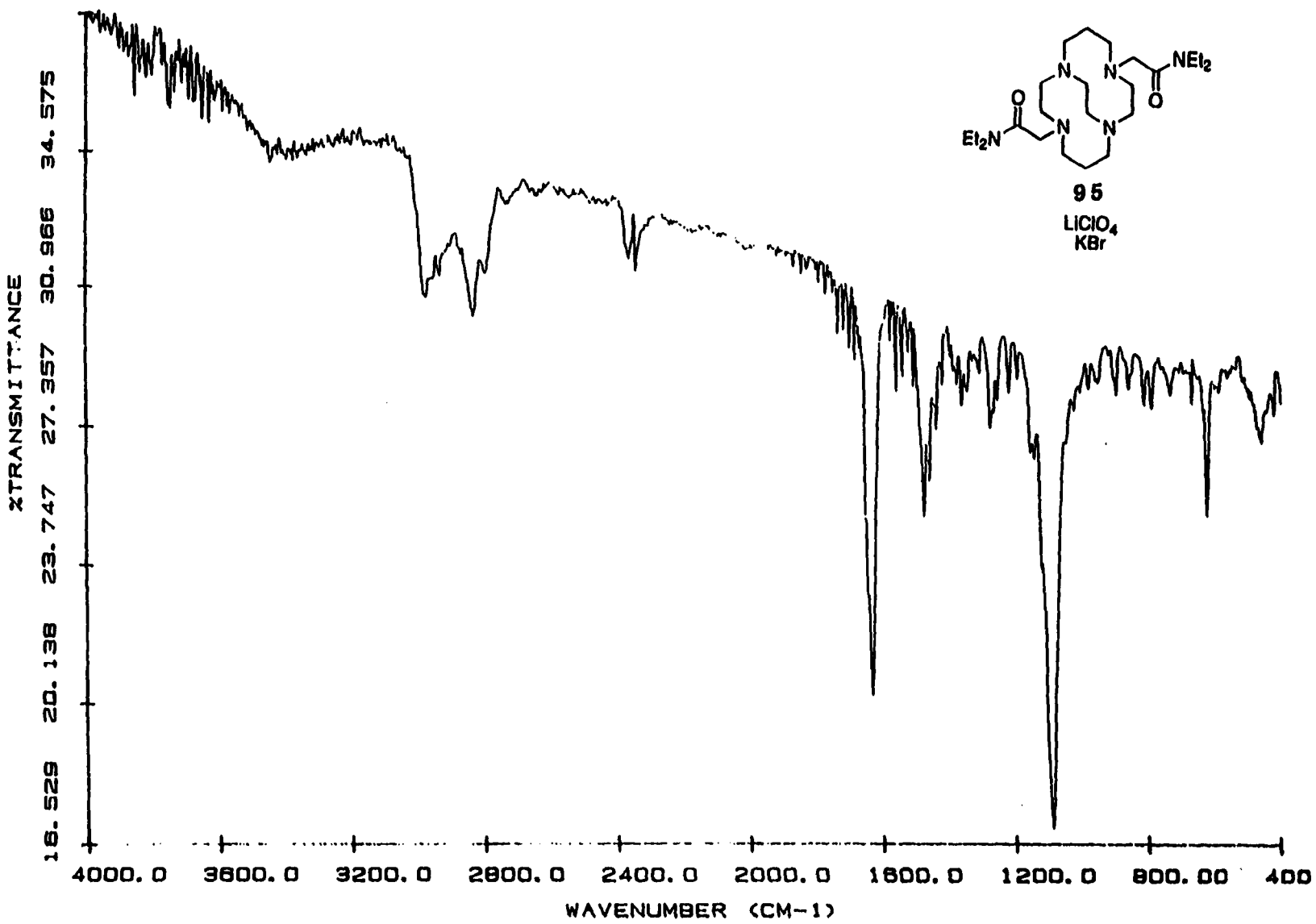

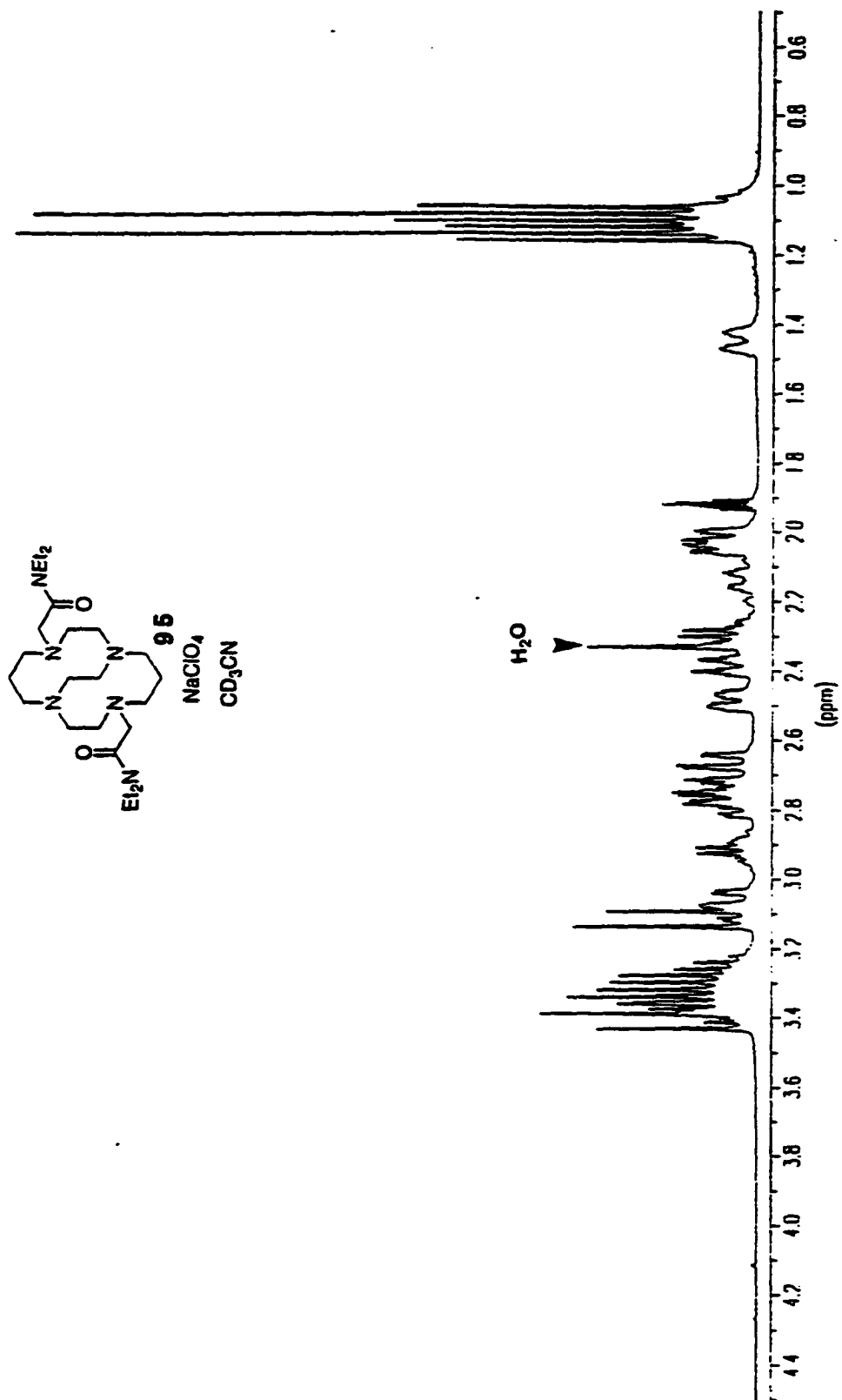

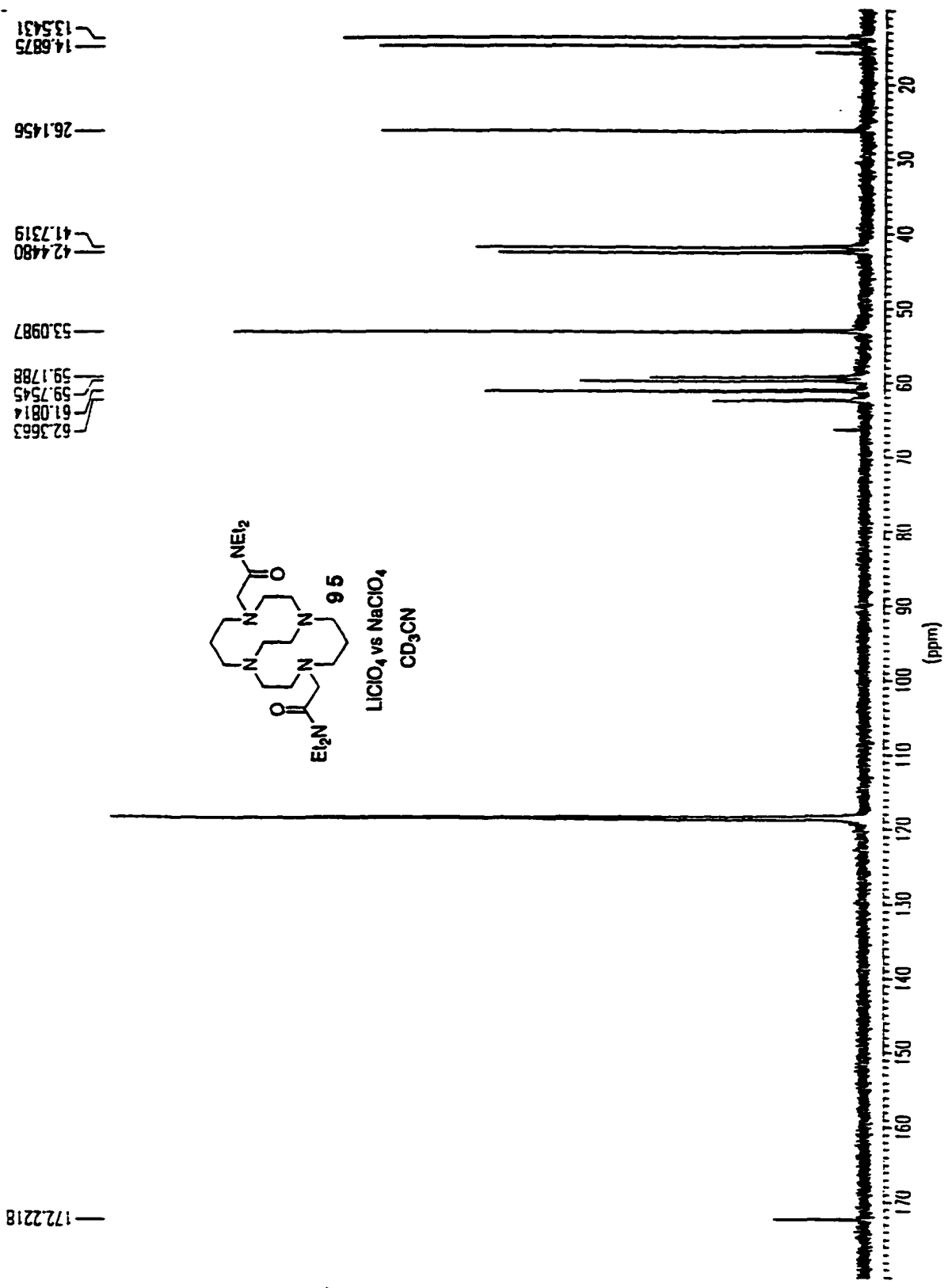

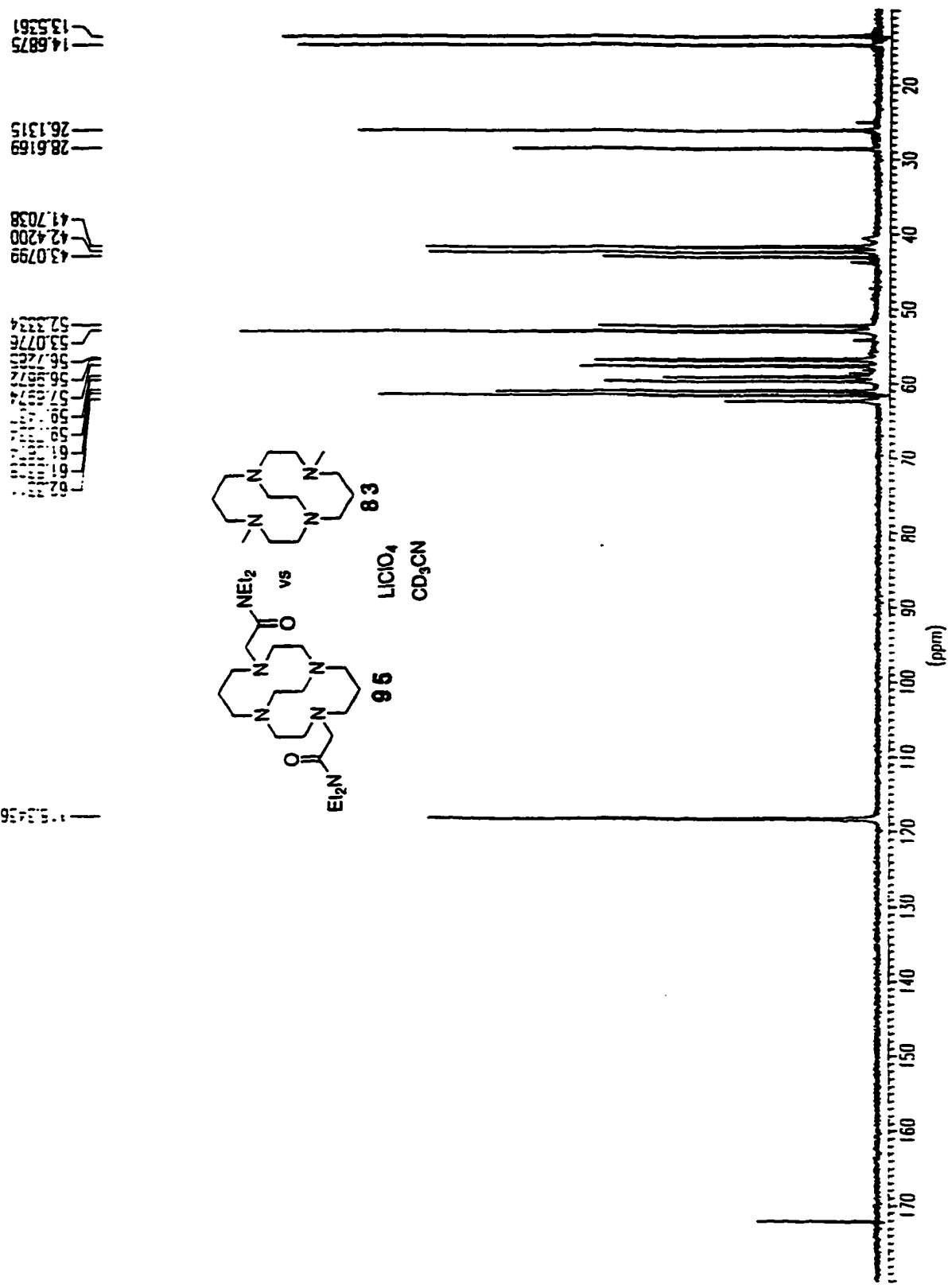

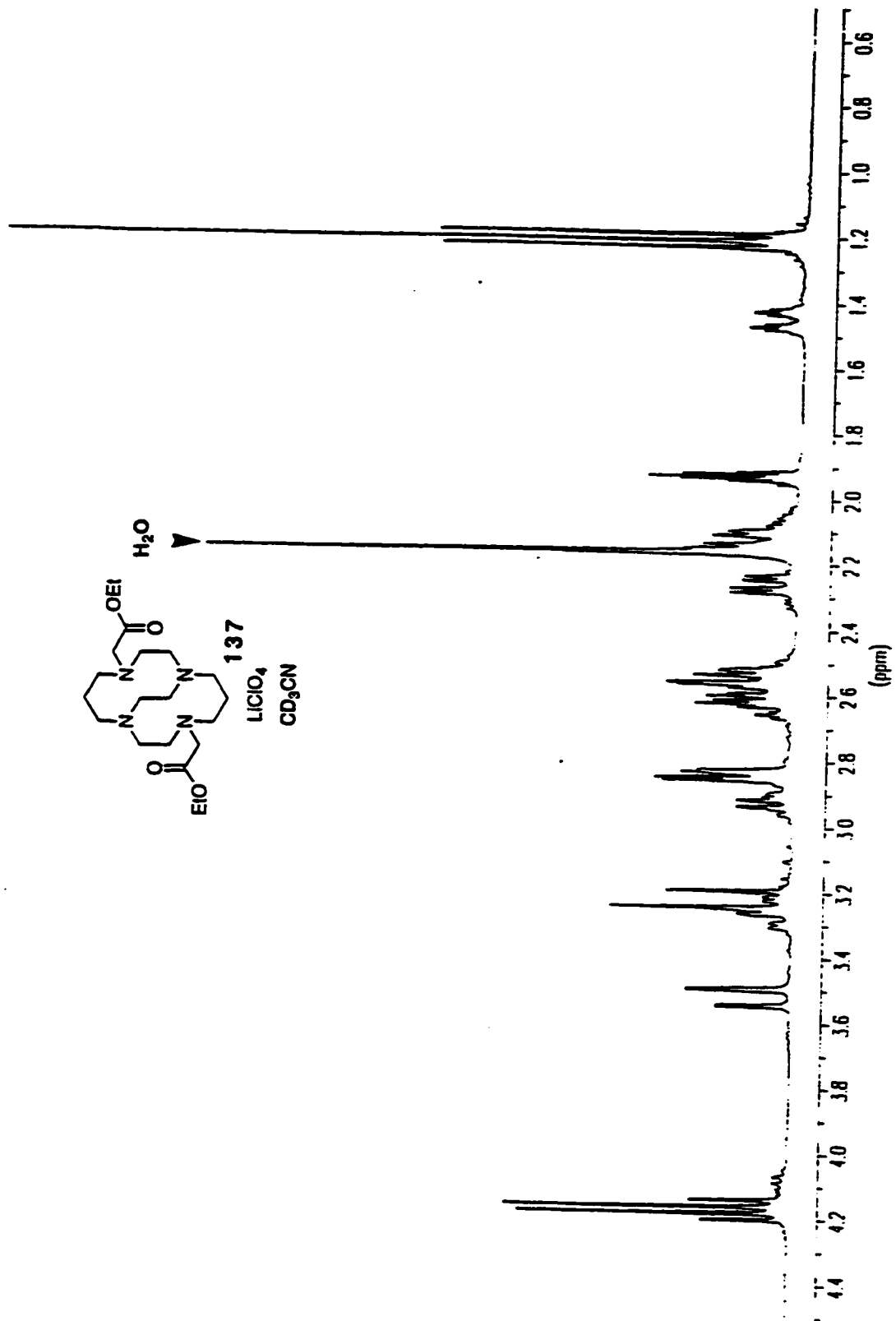

14.4707
25.5293
52.9887
52.8889
59.2295
59.3543
60.3903
62.2500
63.0488

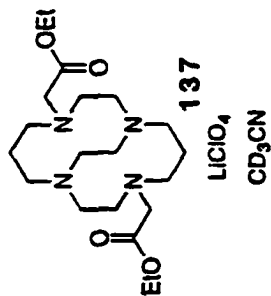

176.5810

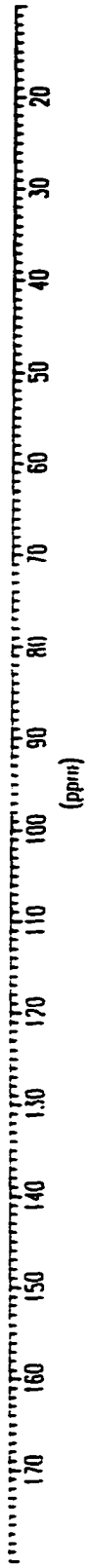

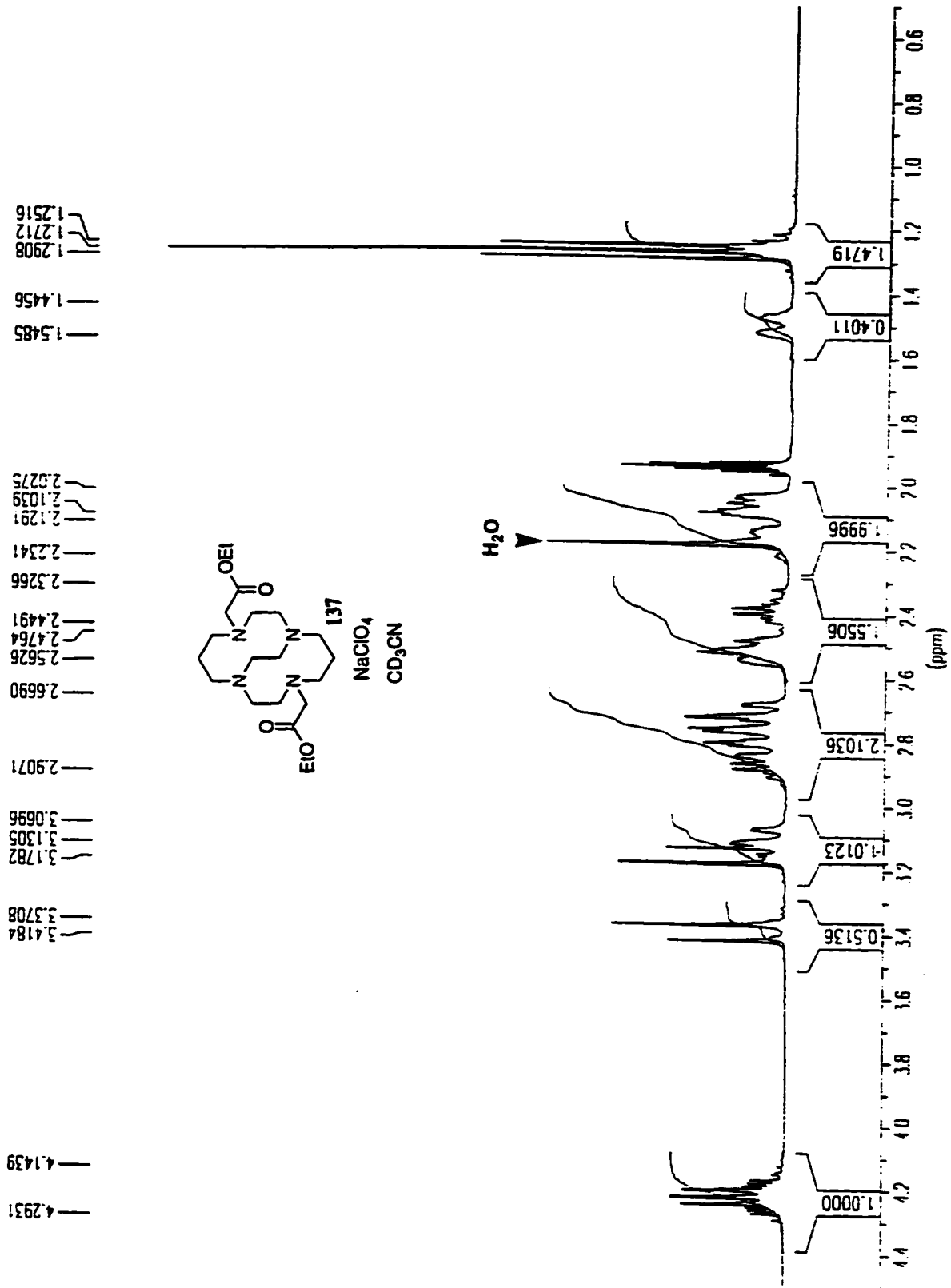

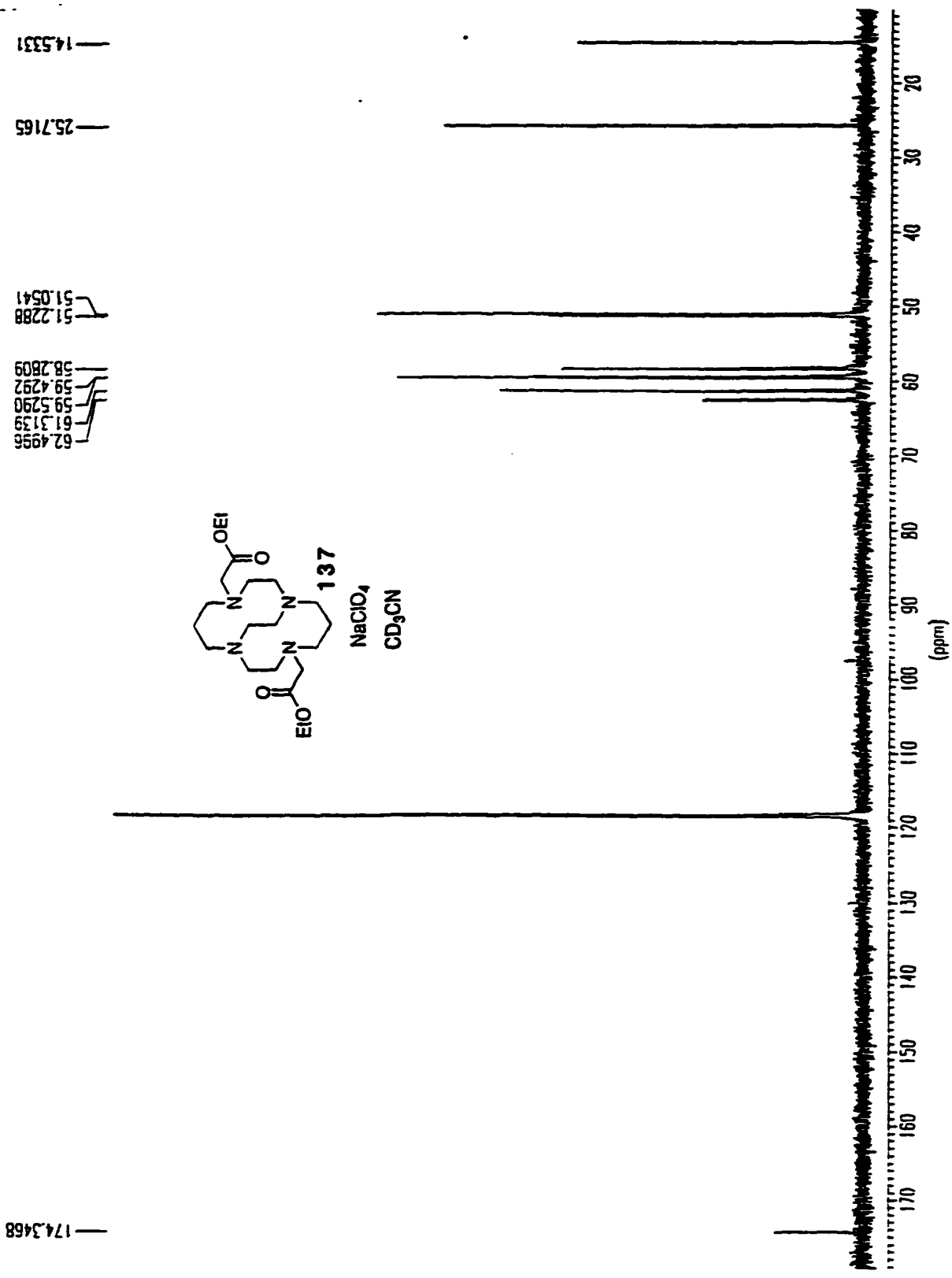

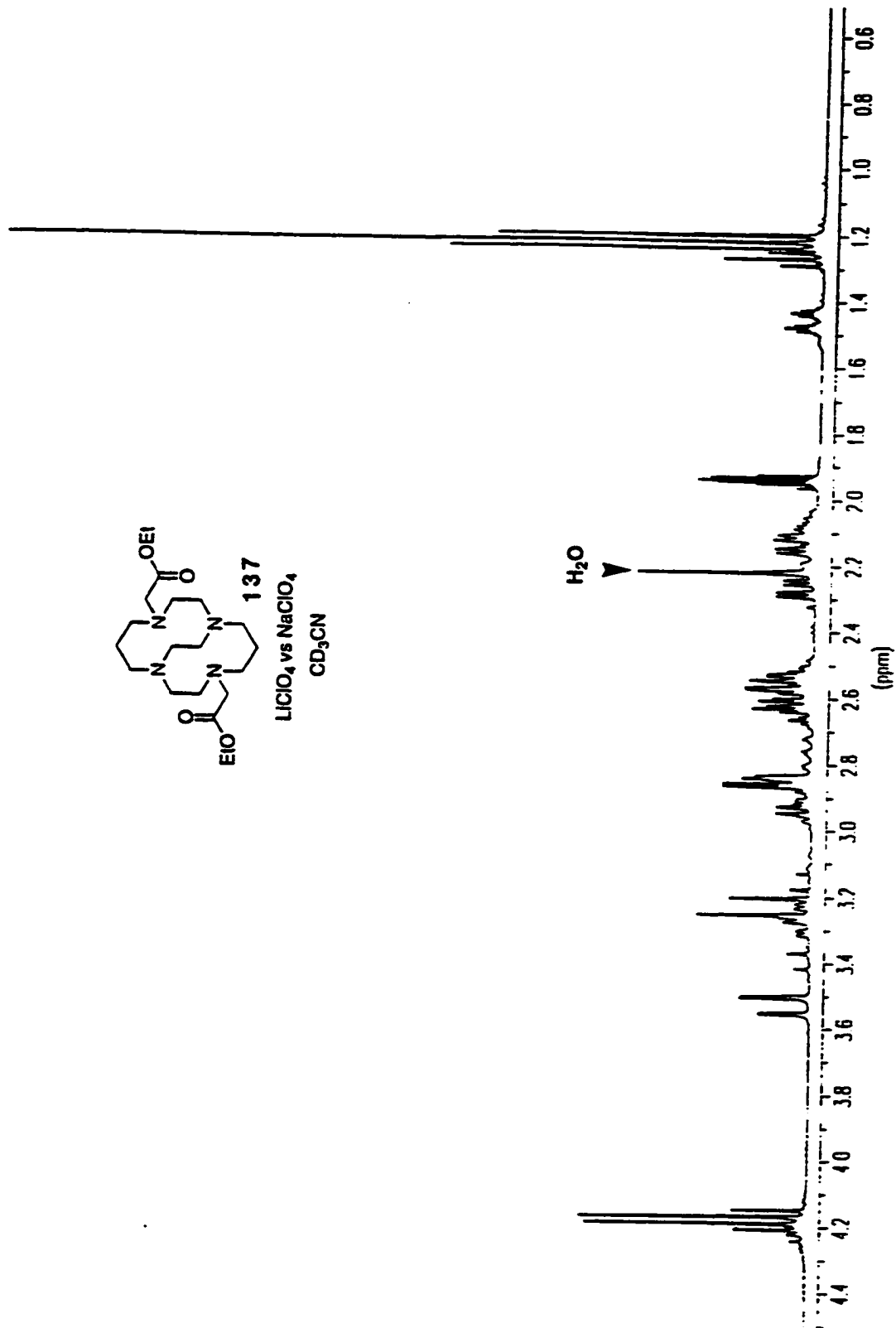
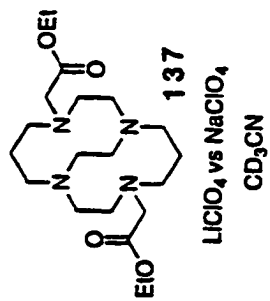

— 7.4403

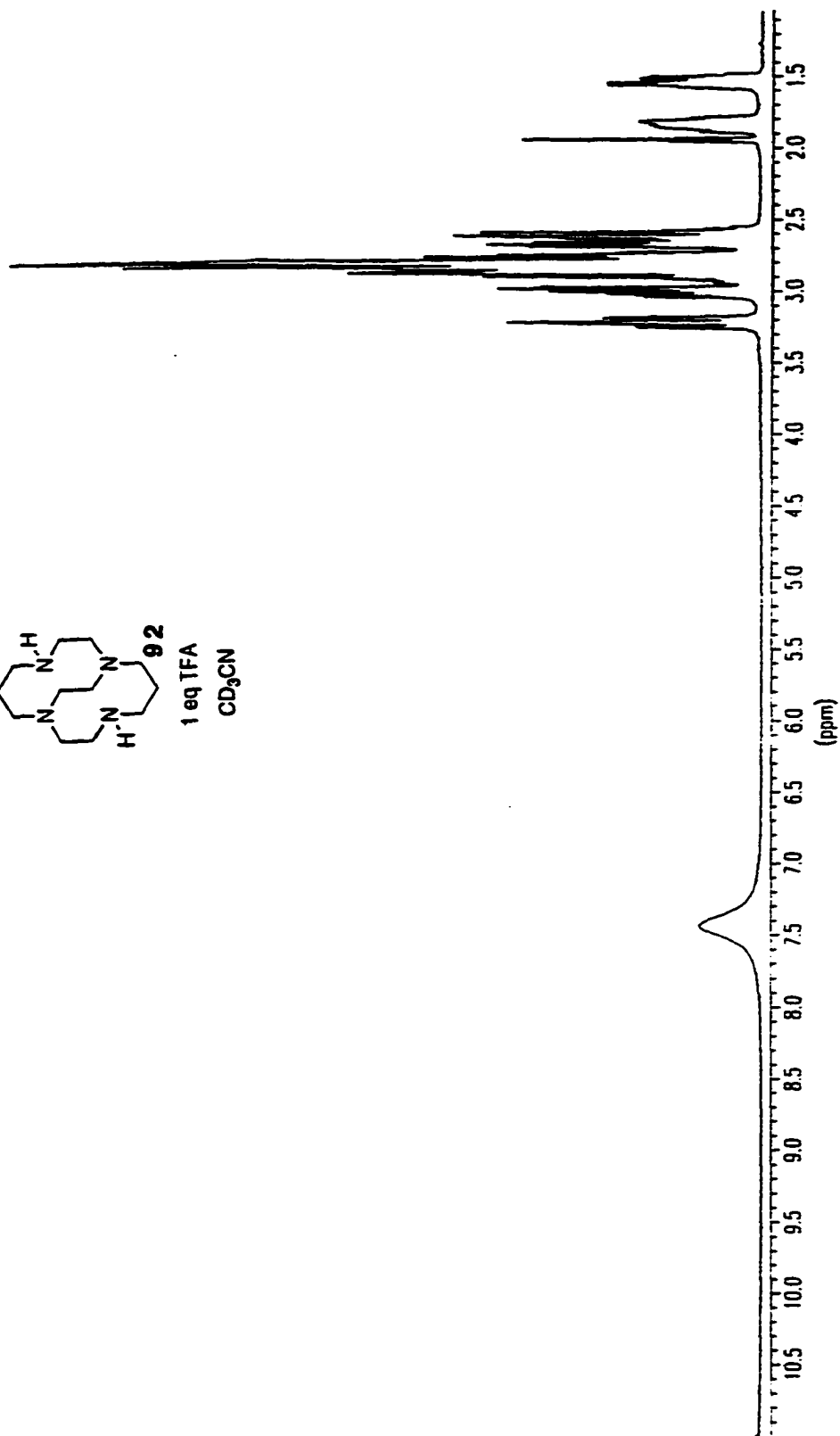
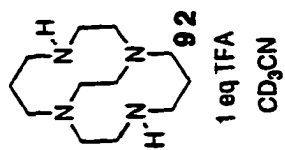

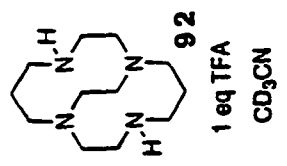
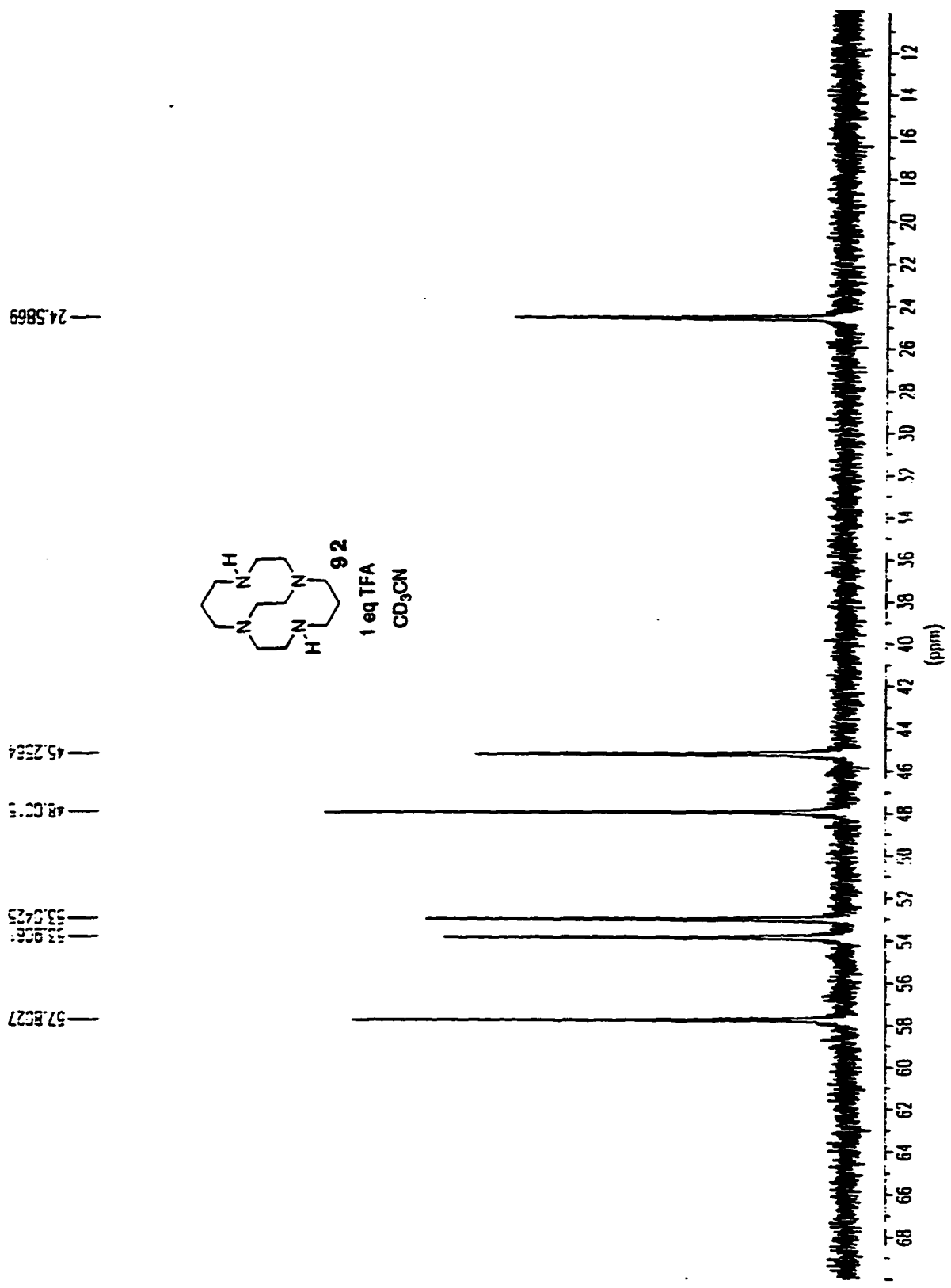

— 9.2710
— 10.1863

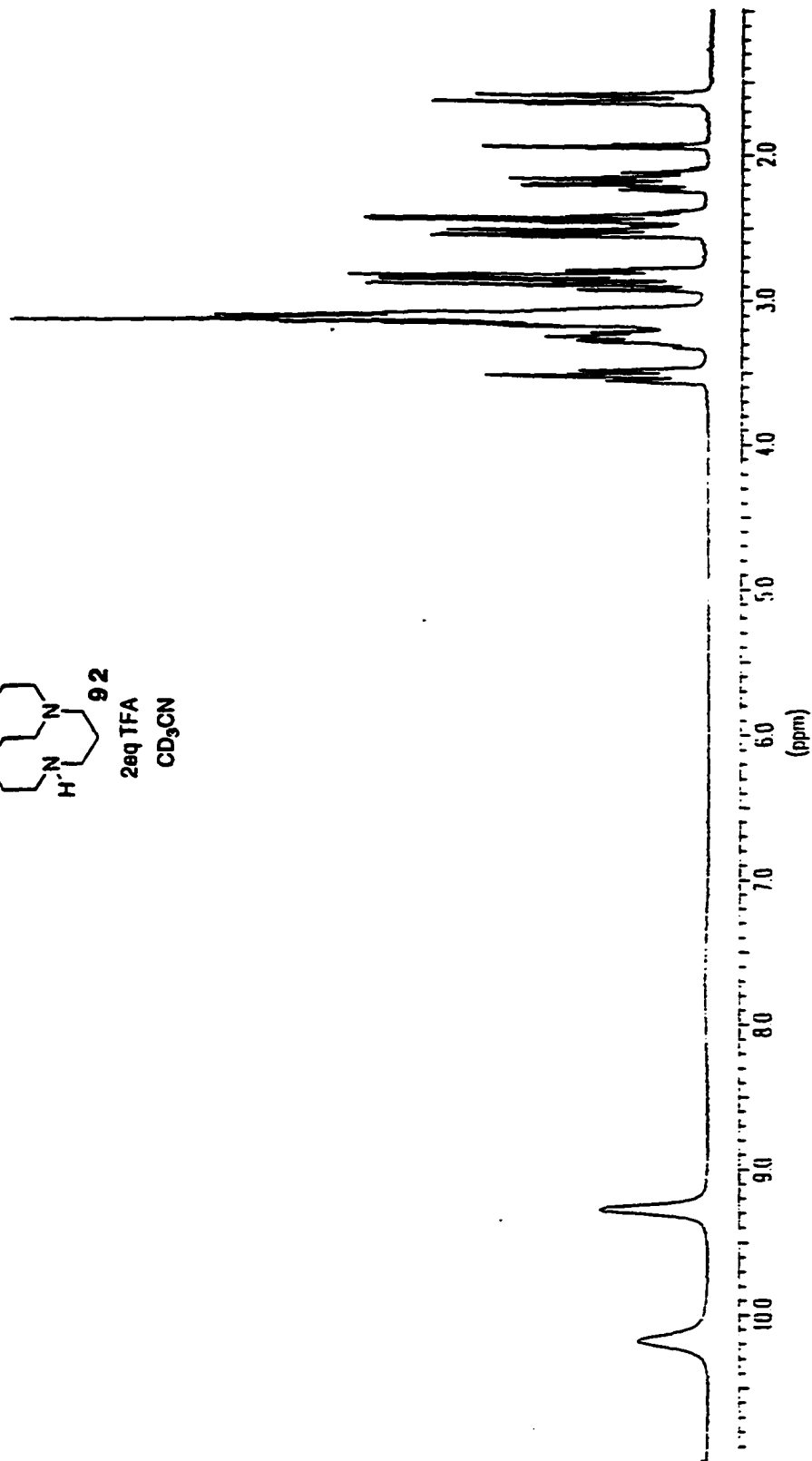
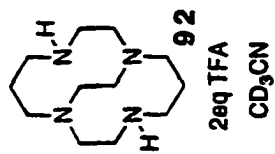

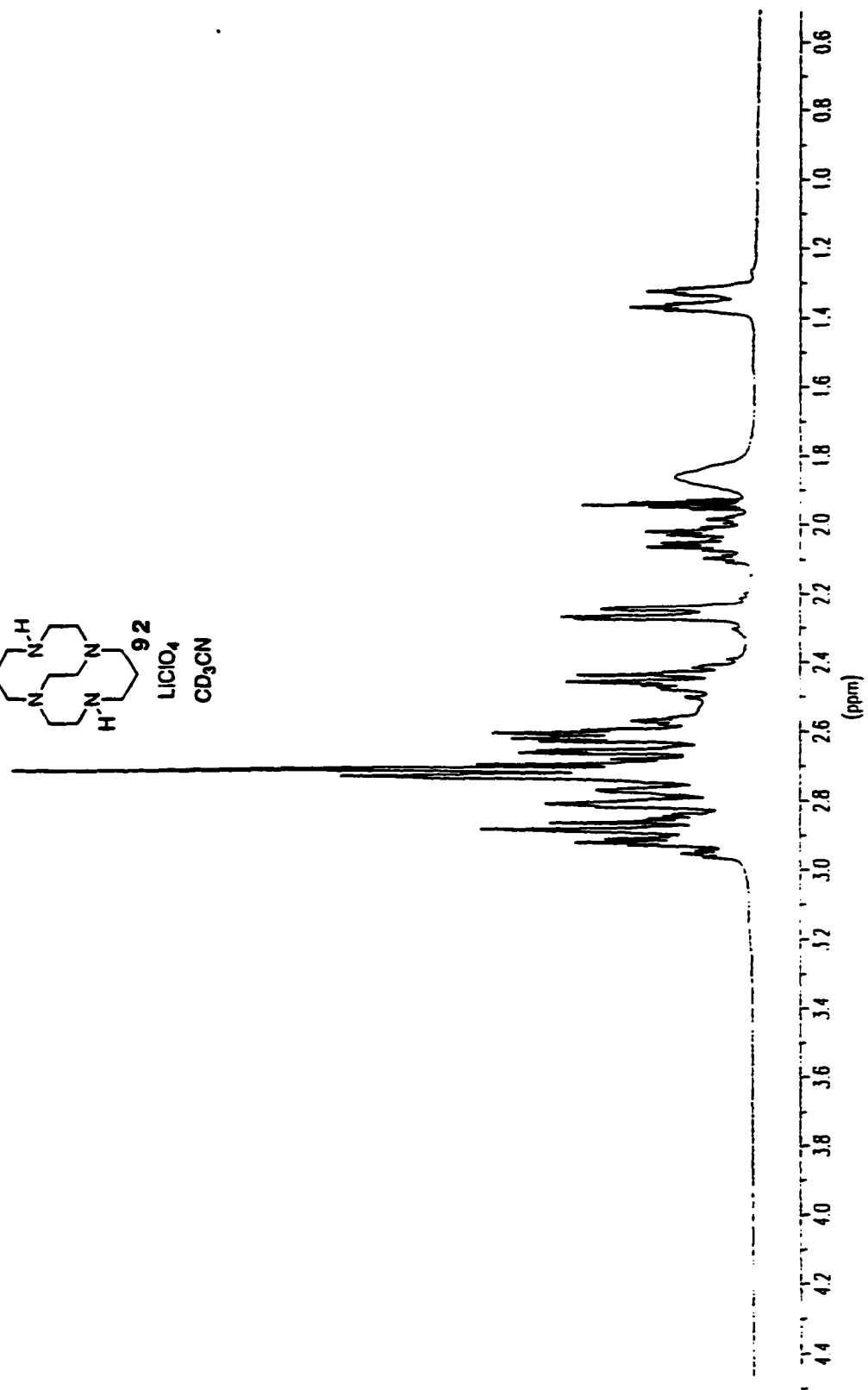
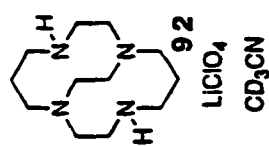

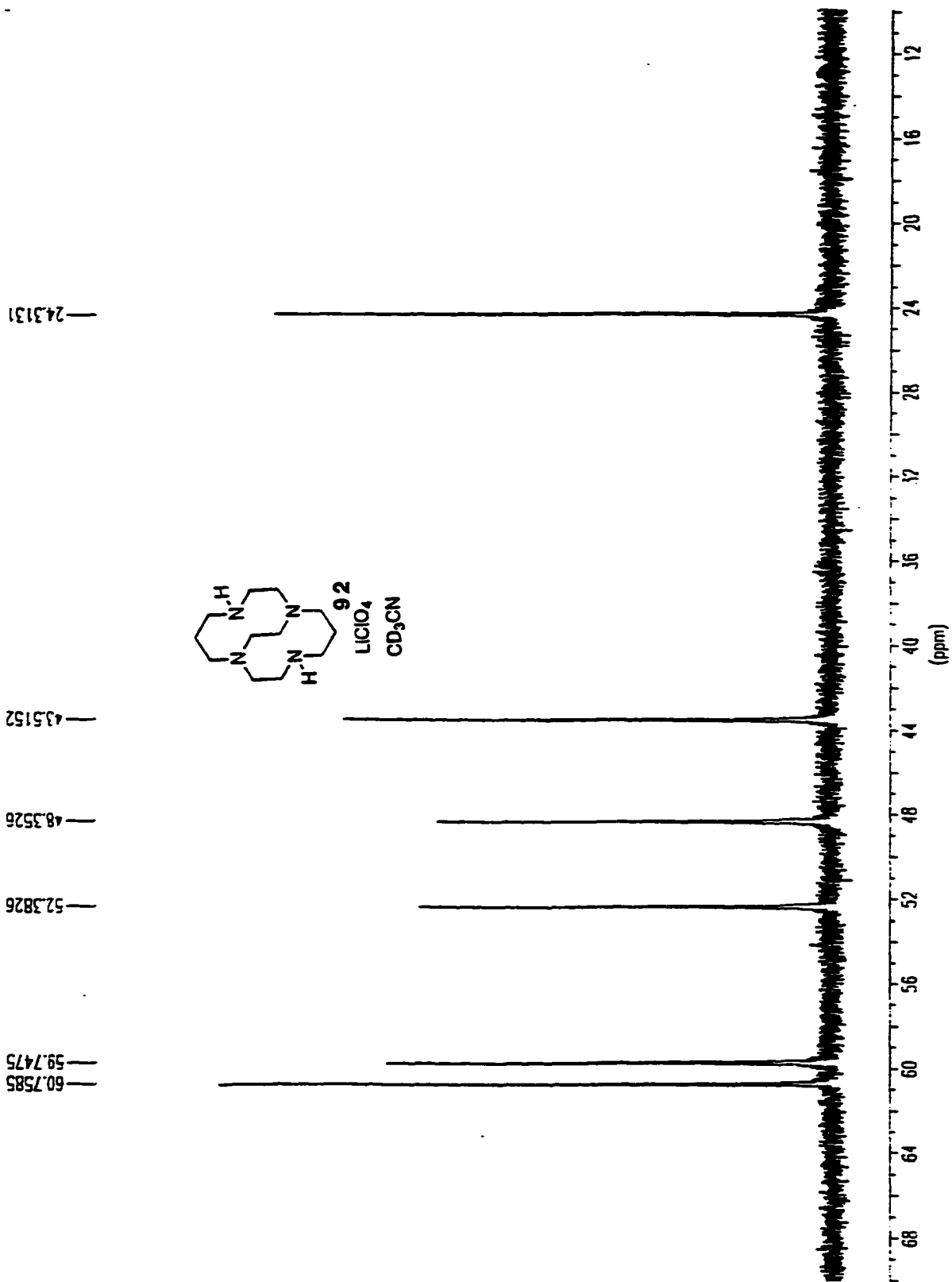

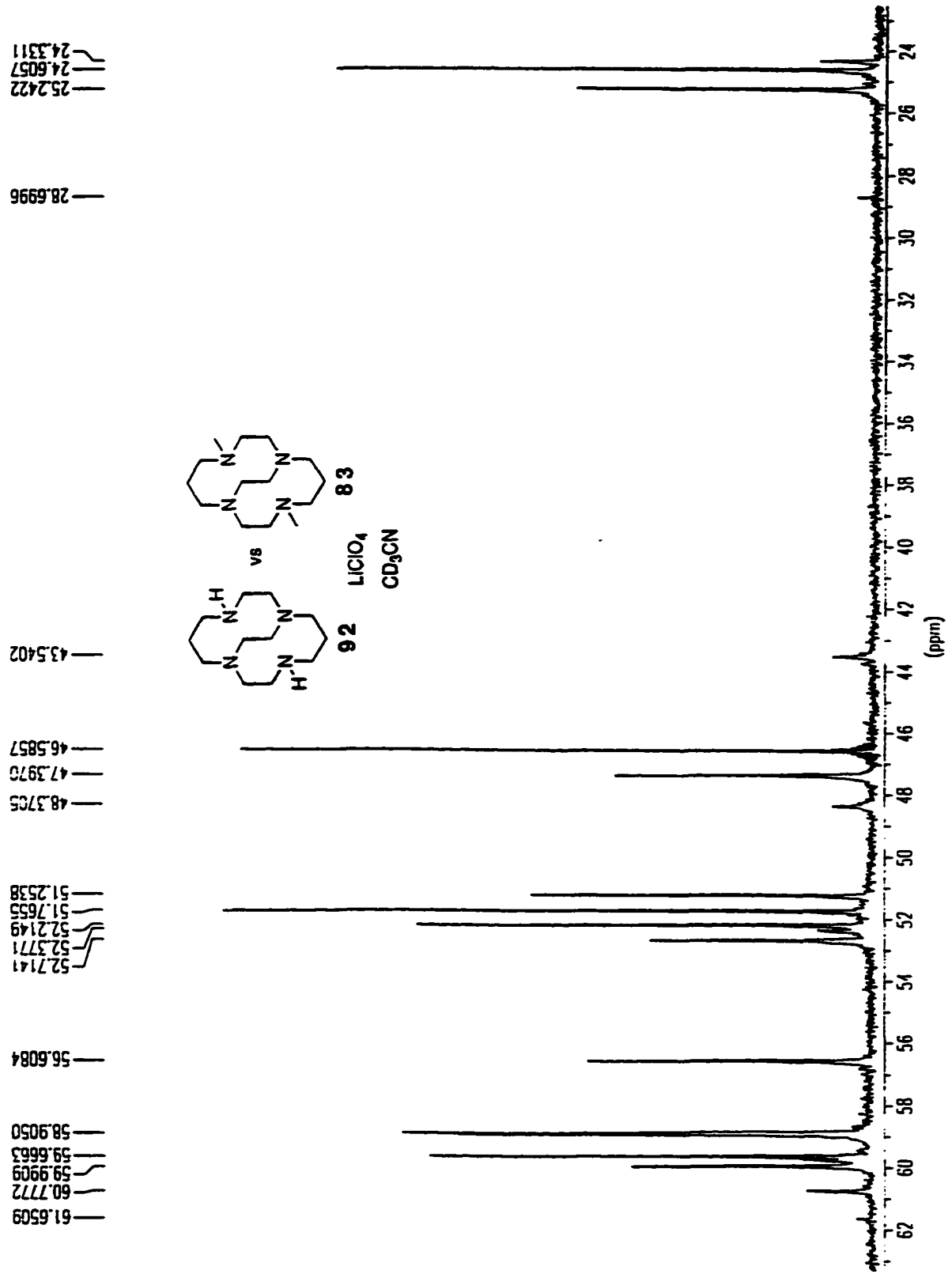

23.4355
24.3202
25.2890
25.7805

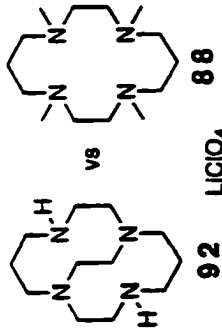

LIClO₄
CD₃CN

42.7289
43.5293

47.3486
48.3737

51.3365
52.3756
52.5160

55.1558
55.7456
56.0264
56.2370
57.7816

59.7756
60.7866

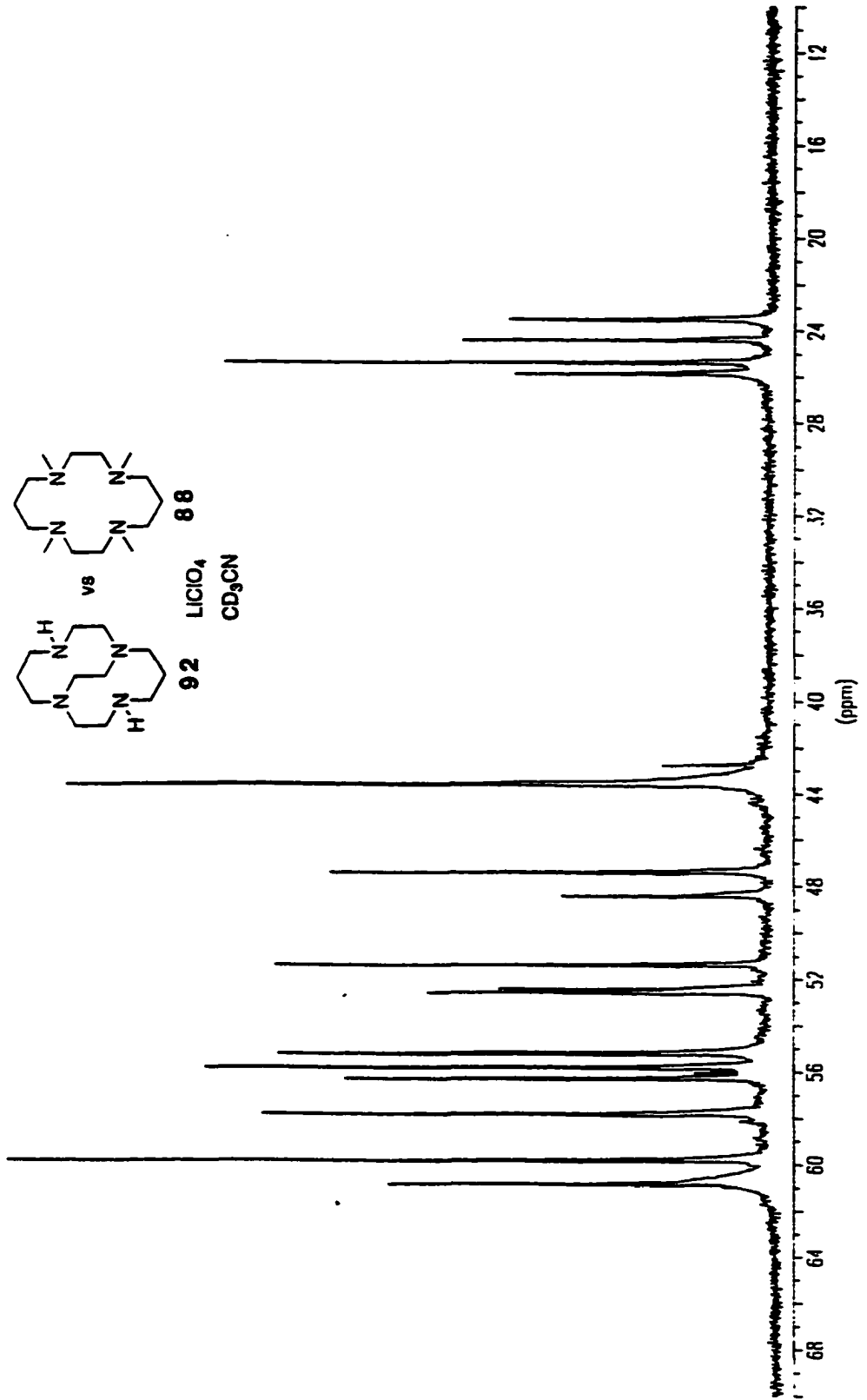

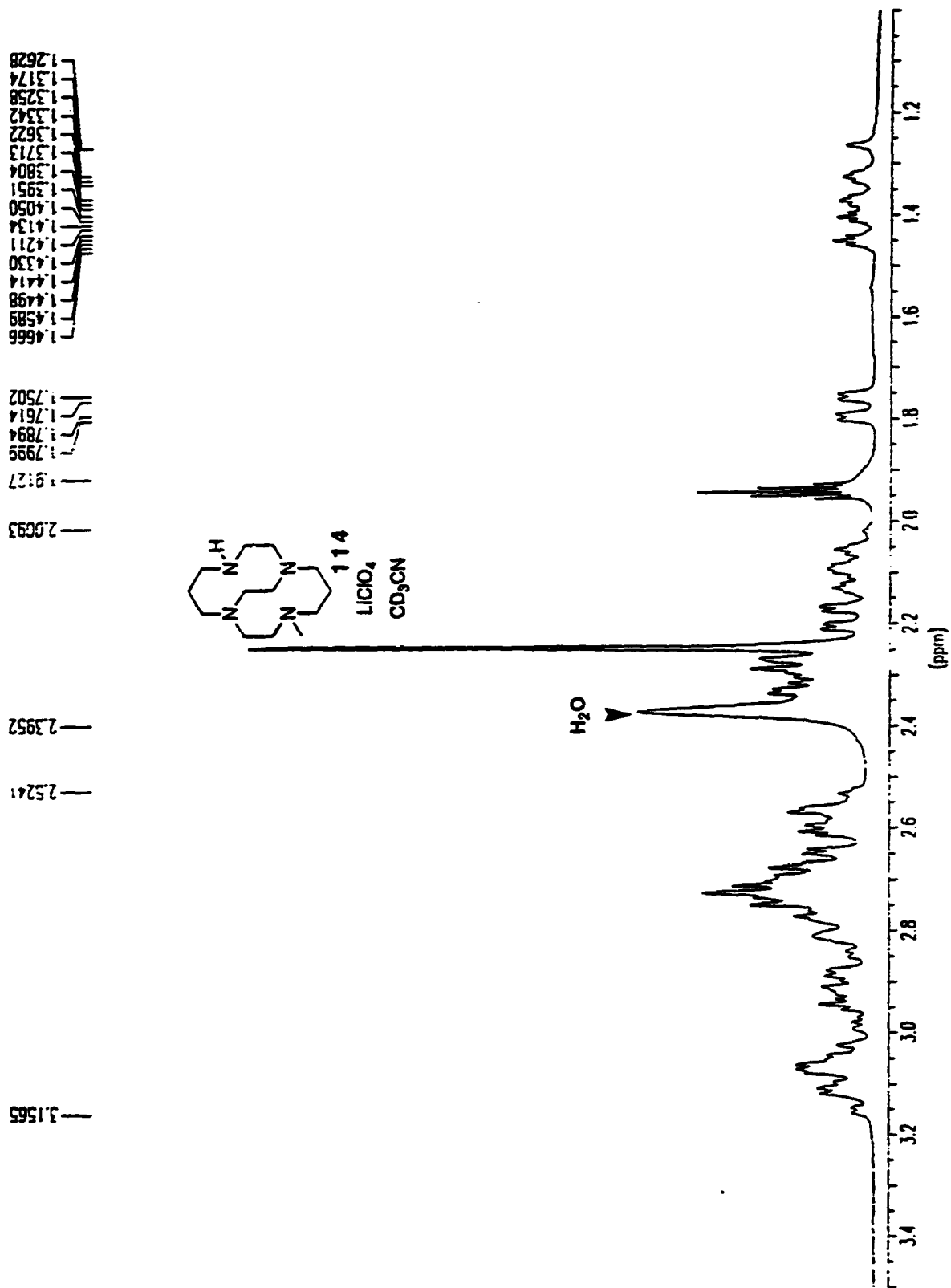

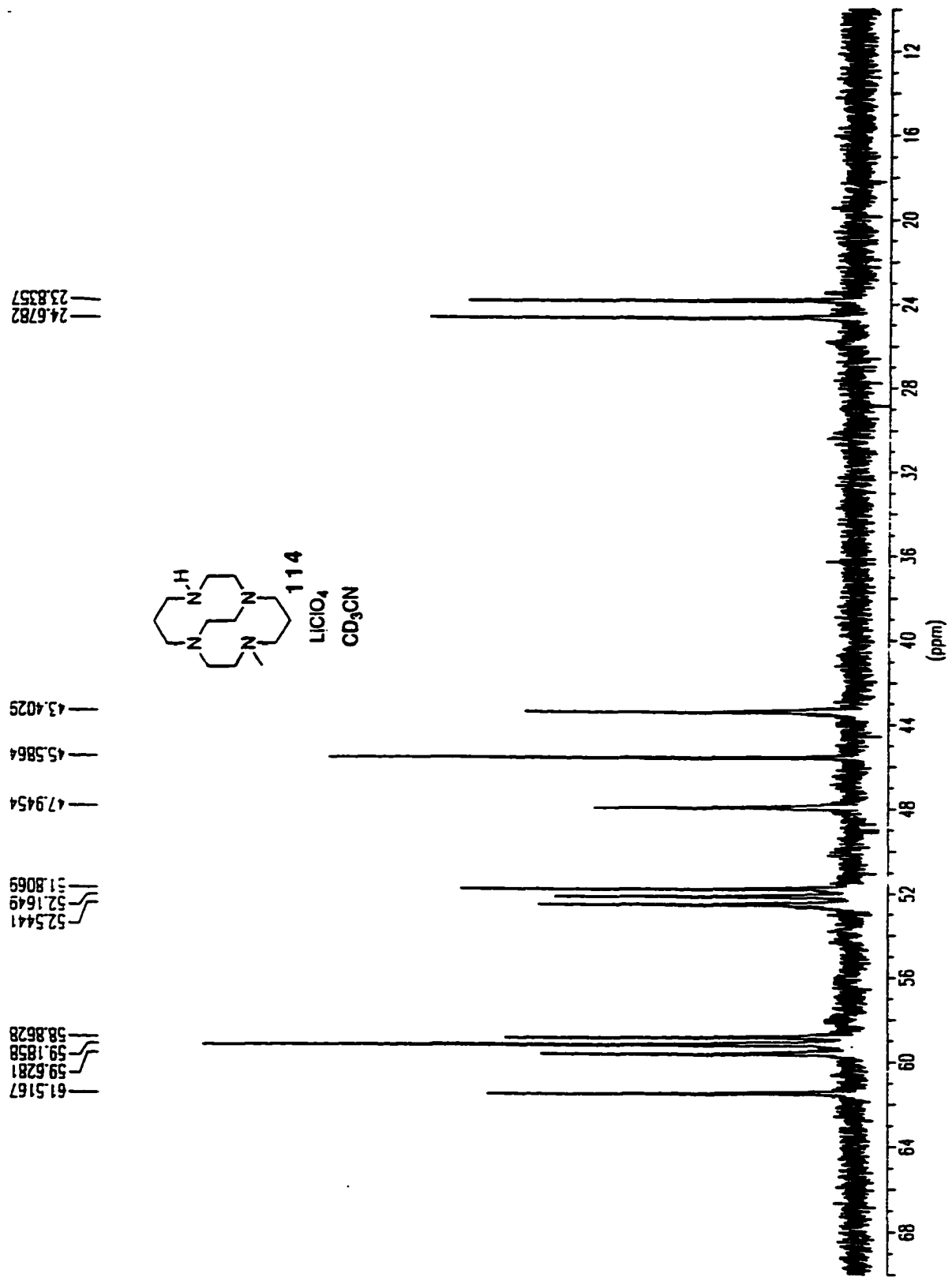

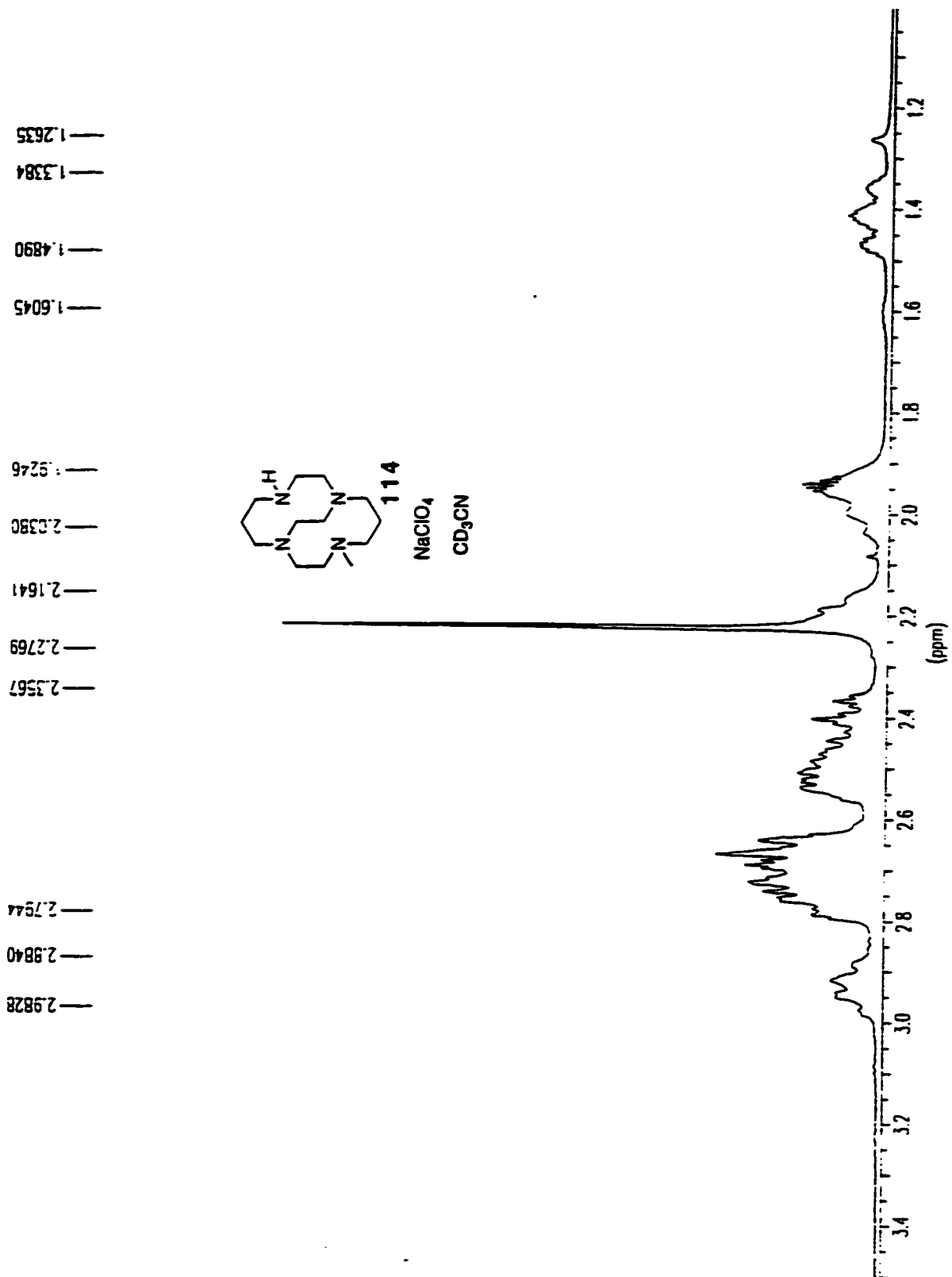

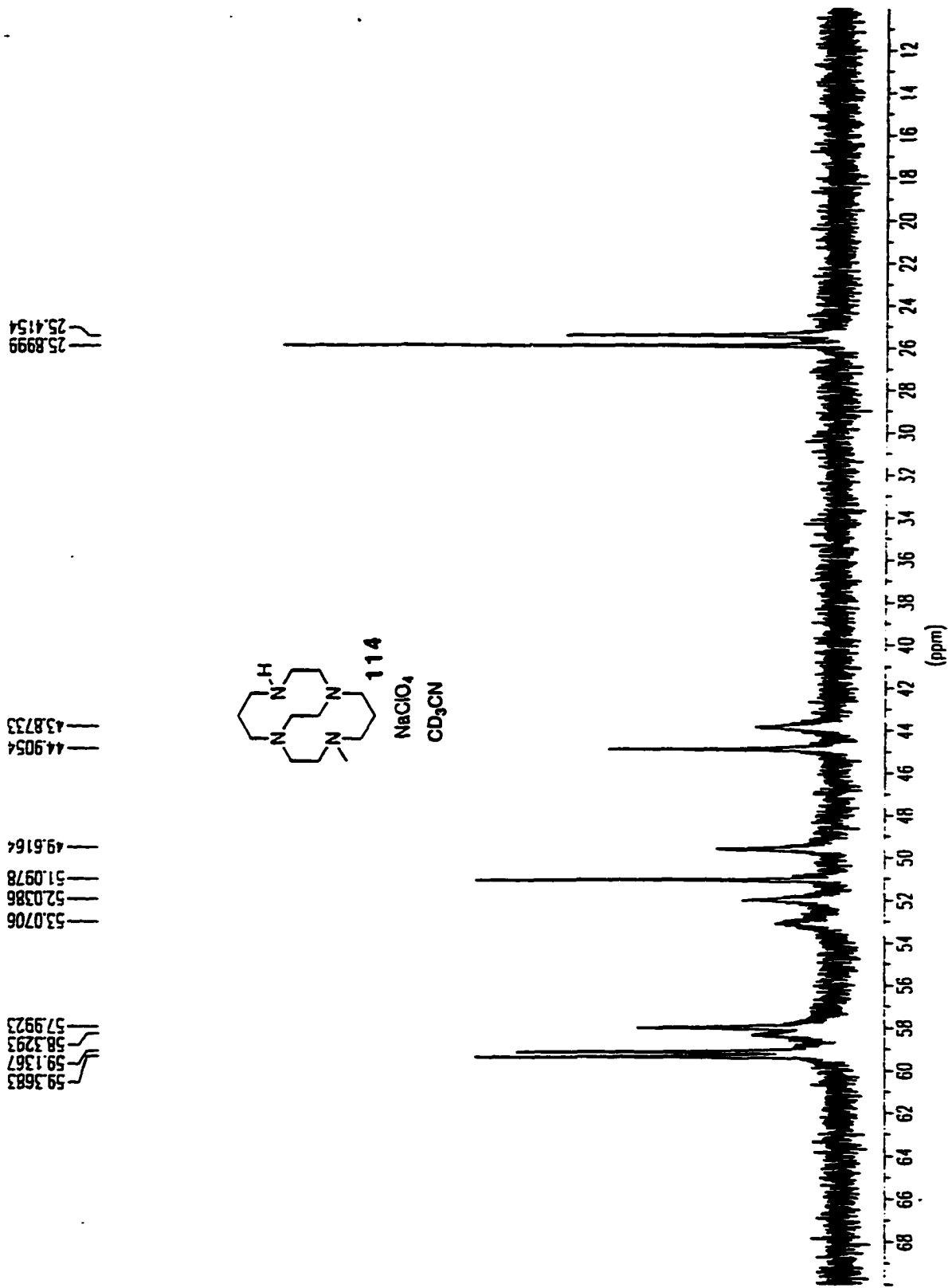

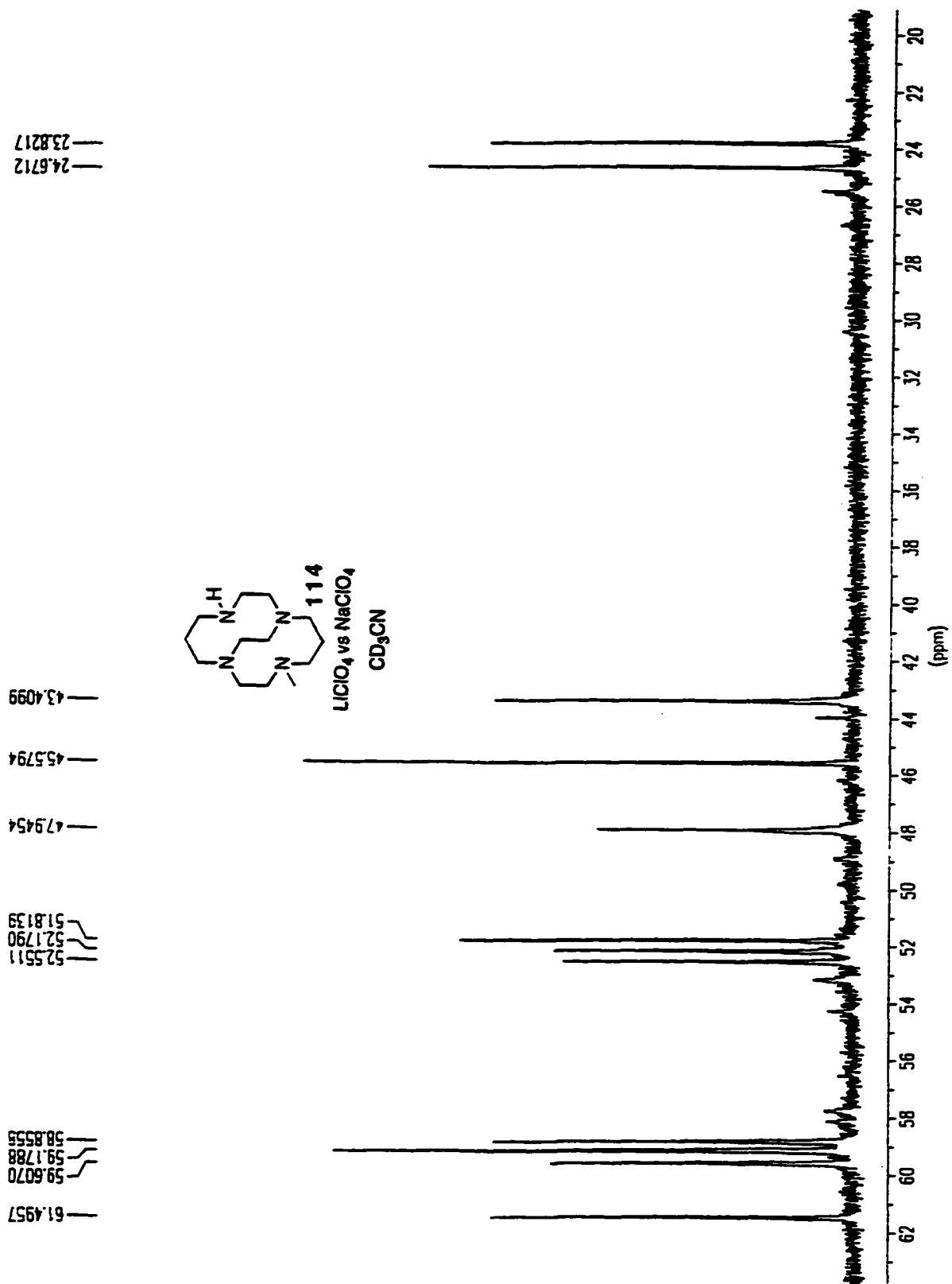

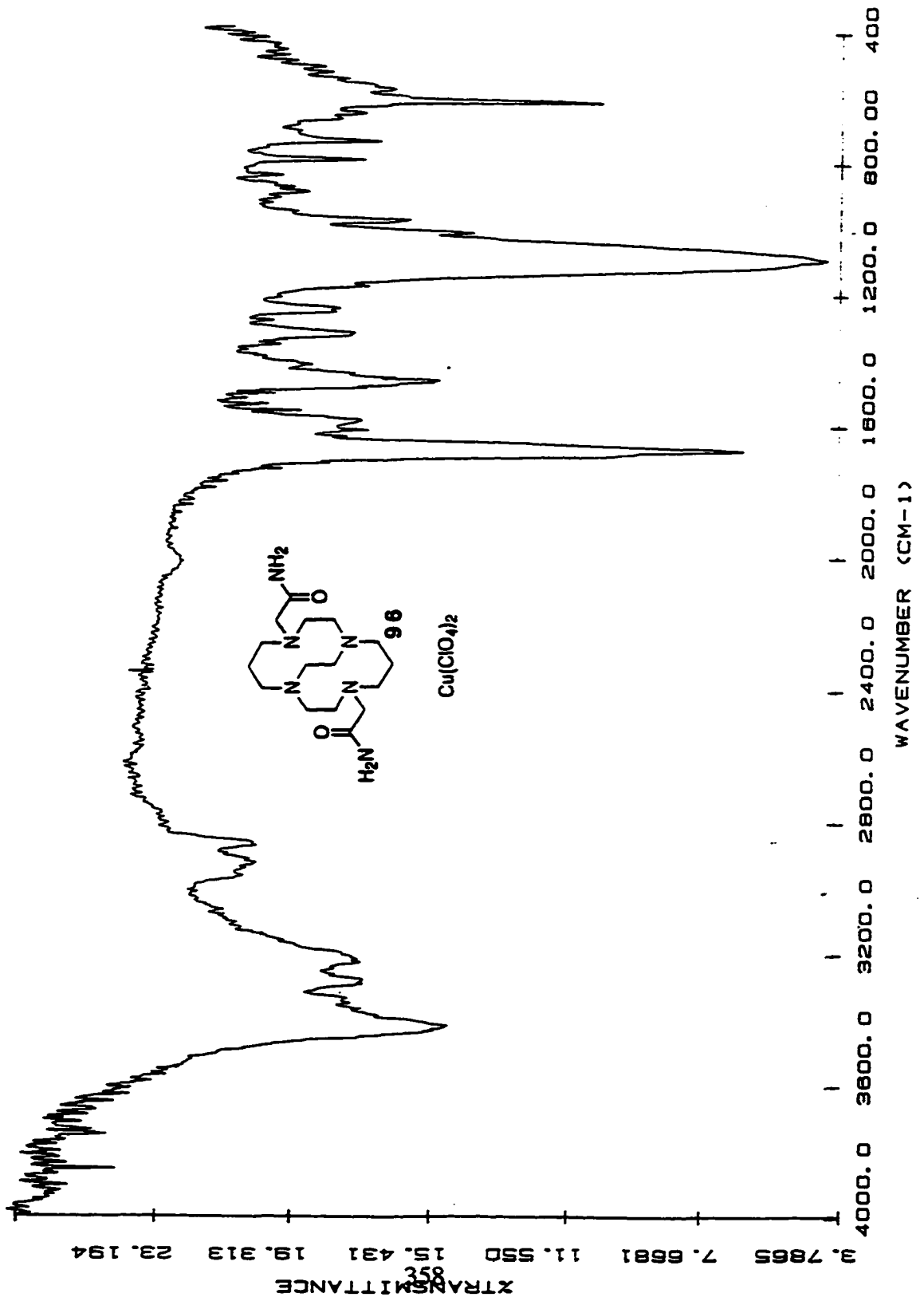

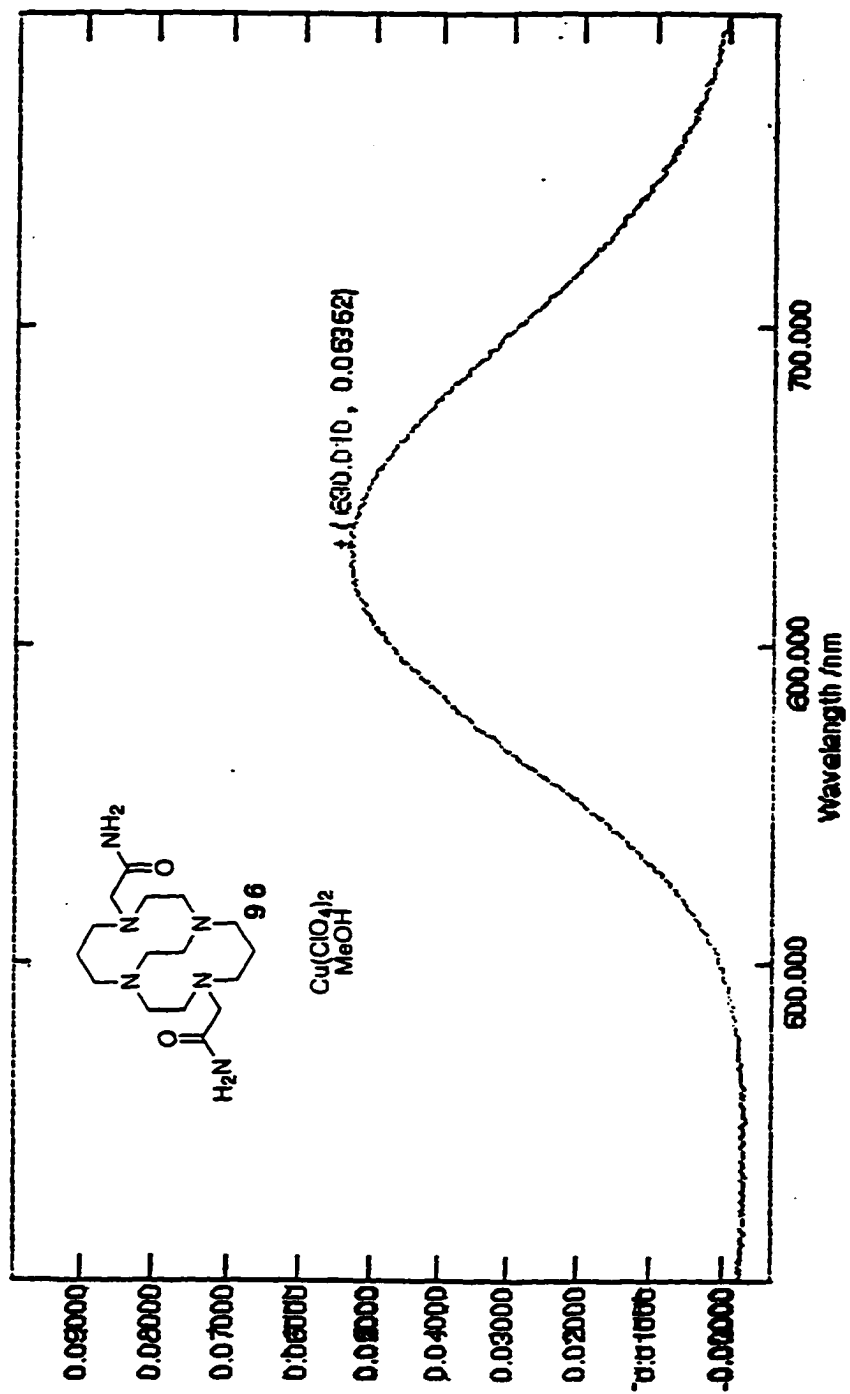

Compound Index

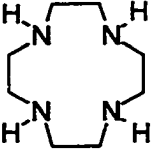
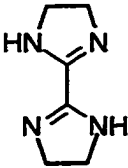
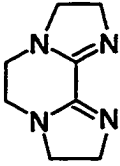
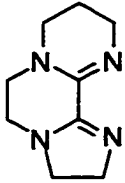
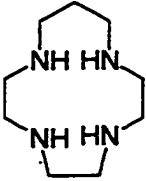
<u>Compound</u>		<u>Page</u>
2		149
11		170
16		146
18		150
19		152

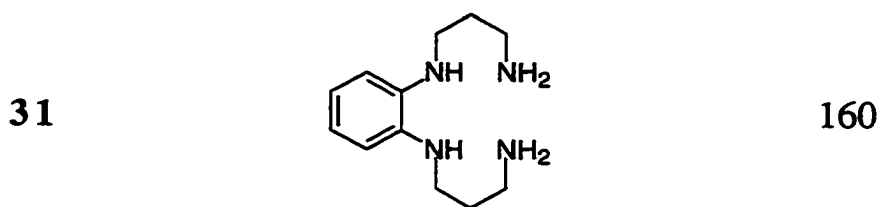
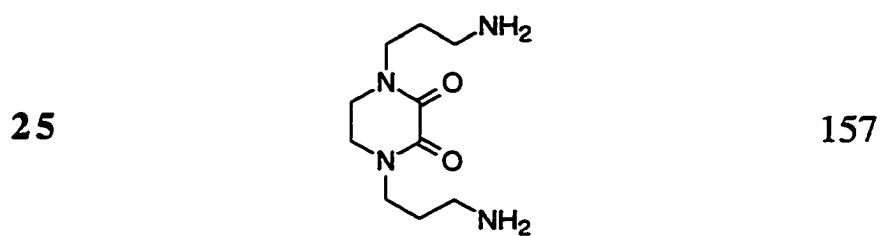
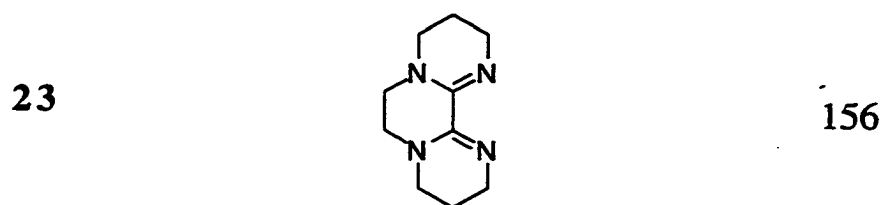
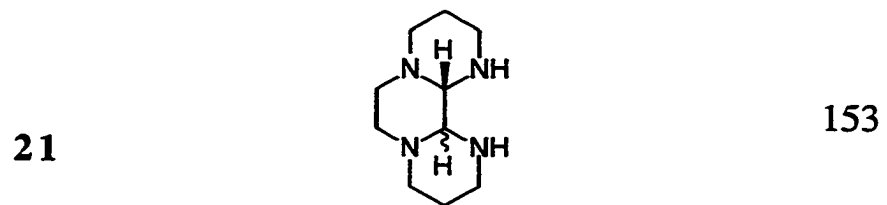
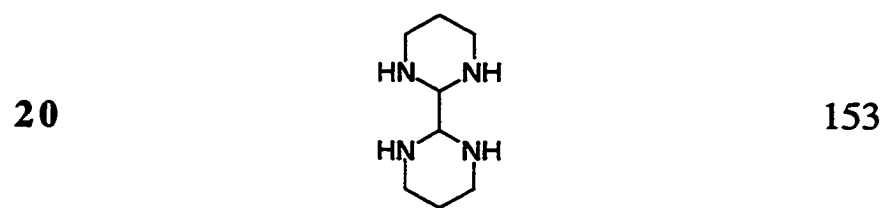

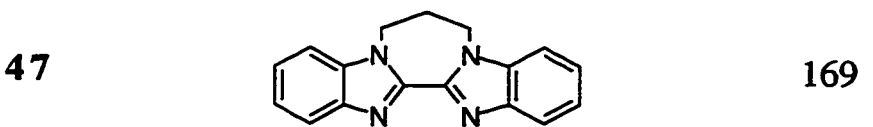
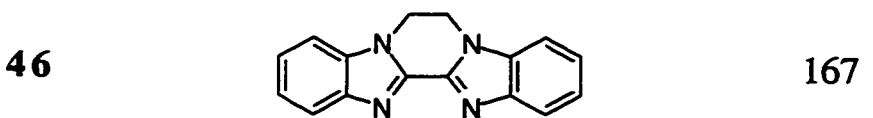
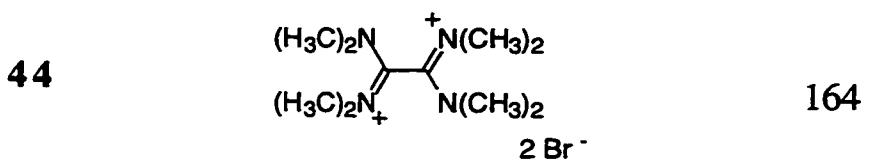
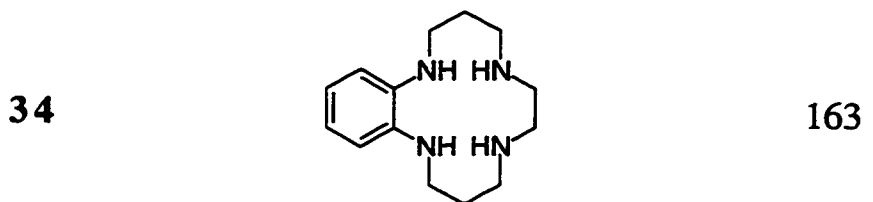
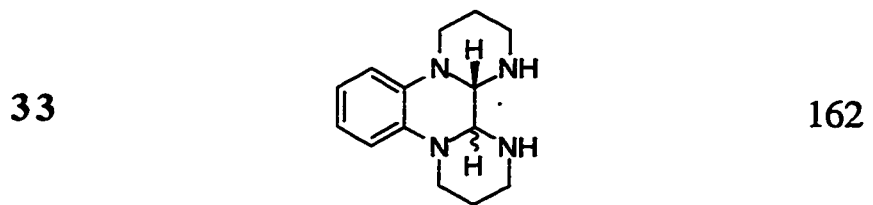
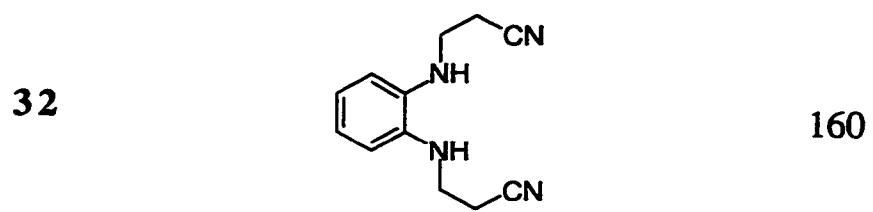

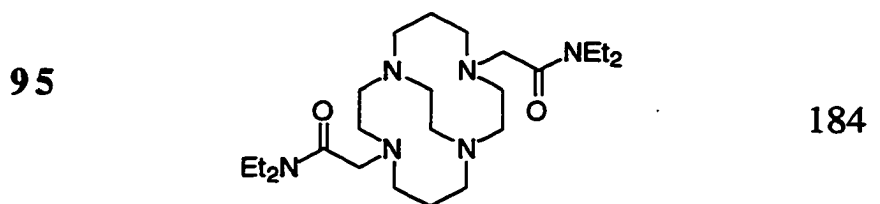
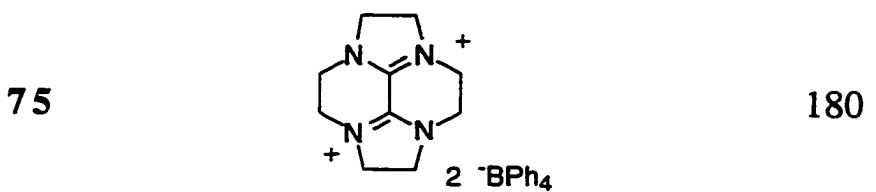
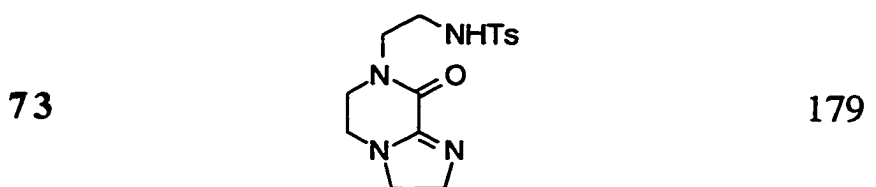
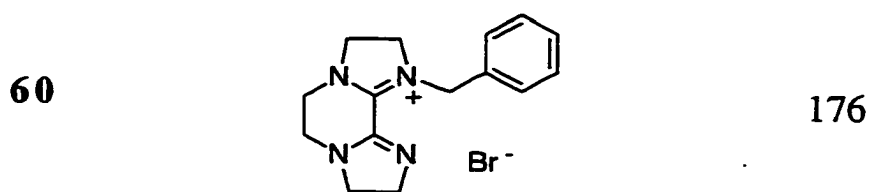
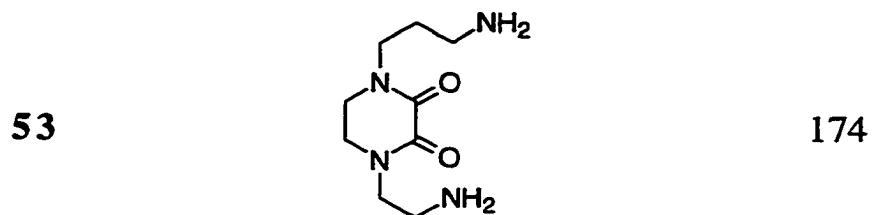
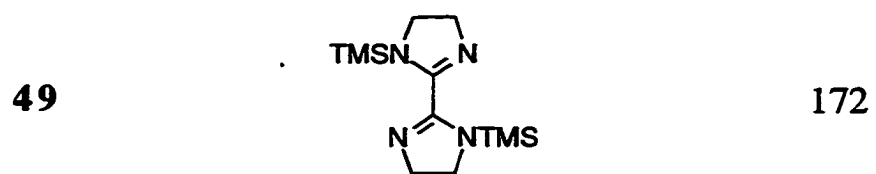

96

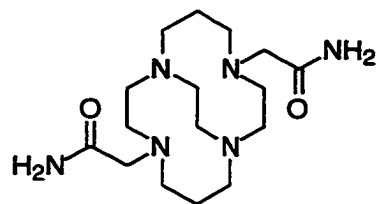

185

98

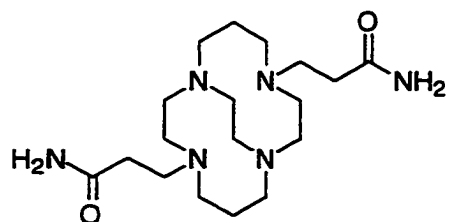

186

107

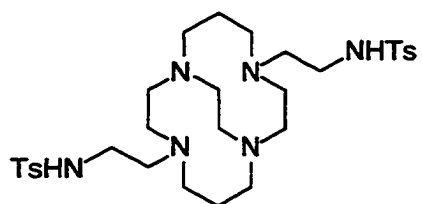

190

118

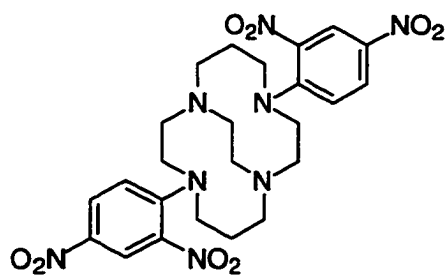

194

119

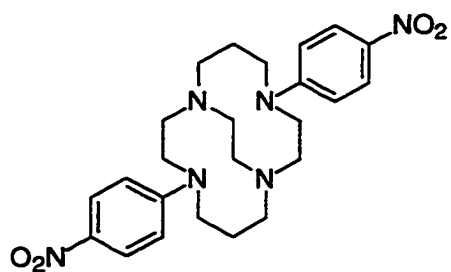

195

125

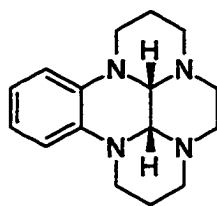

198

126a

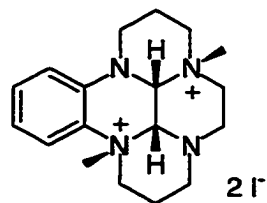

199

130

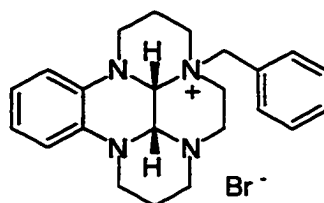

199

References

- (1) Bianchi, A.; Micheloni, M.; Paoletti, P. *Coord. Chem. Rev.* **1991**, *110*, 17.
- (2) Bucsh, D. H. *Rec. Chem. Progress* **1964**, *25*, 107.
- (3) Hancock, R. D.; Martell, A. E. *Chem. Rev.* **1989**, *89*, 1875.
- (4) Kaden, T. A. In *Host Guest Complex Chemistry III*; Vögtle, F., Weber, E., Eds.; Springer-Verlag: Berlin, 1984; Vol. 121, p 157.
- (5) Kaden, T. A. *Pure Appl. Chem.* **1993**, *65*, 1477.
- (6) Kimura, E. *Pure Appl. Chem.* **1989**, *61*, 823.
- (7) DeBlas, A.; De Santis, G.; Fabrizio, G.; Licchelli, L.; Pallavicini, P. *Pure Appl. Chem.* **1993**, *35*, 455.
- (8) Bernhardt, P. V.; Lawrence, G. A. *Coord. Chem. Rev.* **1990**, *104*, 297.
- (9) Wainwright, K. P. *Coord. Chem. Rev.* **1997**, *166*, 35.
- (10) Gokel, G. W.; Dishong, D. M.; Schultz, R. A.; Gatto, V. J. *Synthesis* **1982**, 997.
- (11) Krakowiak, K. E.; Bradshaw, J. S.; Zamecka-Krakowiak, D. J. *Chem. Rev.* **1989**, *89*, 929.
- (12) Parker, D. *Macrocyclic Synthesis. A Practical Approach*; Oxford University Press: Oxford, 1996.
- (13) Parker, D. In *Crown Compounds*; Cooper, S. R., Ed.; VCH: New York, 1992.
- (14) Lippard, S. J.; Berg, J. M. *Principles of Bioinorganic Chemistry*; University Science Books: Mill Valley, CA, 1994.
- (15) Jurisson, S.; Berning, D.; Jia, W.; Ma, D. *Chem. Rev.* **1993**, *93*, 1137.
- (16) Lauffer, R. B. *Chem. Rev.* **1987**, *87*, 901.
- (17) Parker, D. *Chem. Soc. Rev.* **1990**, *19*, 271.
- (18) Bridger, G. J.; Skerlj, R. T.; Thorton, D.; Padmanabhan, S.; Martellucci, S. A.; Henson, G. W.; Abrams, M. J.; Yamamoto, N.; Vreese, K. D. *J. Med. Chem.* **1995**, *38*, 366.

- (19) Bridger, G. J.; Skerlj, R. T.; Padmanabhan, S.; Thorton, D. *J. Org. Chem.* **1996**, *61*, 1519.
- (20) Bradshaw, J. S.; Krakowiak, K. E.; Izatt, R. M. In *The Chemistry of Heterocyclic Compounds*; Taylor, E. C., Ed.; Wiley: New York, 1993; Vol. 51.
- (21) Ito, T.; Kato, M.; Yamashita, M.; Ito, H. *J. Coord. Chem.* **1986**, *15*, 29.
- (22) Kaden, T. In *Crown Compounds*; Cooper, S. R., Ed.; VCH: New York, 1992, p 135.
- (23) Kaden, T. *Adv. Supramol. Chem.* **1993**, *3*, 135.
- (24) Trost, B. M. *Science* **1991**, *254*, 1471.
- (25) Alphen, J. V. *Recl. Trav. Chim. Pays-Bas* **1937**, *56*, 343.
- (26) Stetter, H.; Mayer, K.-H. *Chem. Ber.* **1961**, *94*, 1410.
- (27) Bosnich, B.; Poon, C. K.; Tobe, M. L. *Inorg. Chem.* **1965**, *4*, 1102.
- (28) Richman, J. E.; Atkins, T. J. *J. Am. Chem. Soc.* **1974**, *96*, 2268.
- (29) Atkins, T. J.; Richman, J. E.; Oettle, W. F. *Org. Synth.* **1978**, *58*, 86.
- (30) Stetter, H.; Roos, E.-E. *Chem. Ber.* **1954**, 566.
- (31) Rasshofer, W.; Vögtle, F. *Liebigs. Ann. Chem.* **1978**, 552.
- (32) Vriesema, B. K.; Butler, J.; Kellogg, R. M. *J. Org. Chem.* **1984**, *49*, 110.
- (33) Chavez, F.; Sherry, A. D. *J. Org. Chem.* **1989**, *54*, 2990.
- (34) Ostrowicki, A.; Keopp, E.; Vogtle, F. *Top. Curr. Chem.* **1992**, *161*, 37.
- (35) Barefield, K. *Inorg. Chem.* **1972**, *11*, 2273.
- (36) Barefield, E. K.; Wagner, F.; Herlinger, A. W.; Dahl, A. R. *Inorg. Synth.* **1976**, *16*, 220.
- (37) Barefield, K.; Feeman, G.; English, D. R. *Inorg. Synth.* **1980**, *20*, 108.
- (38) Yamamoto, H.; Maruoka, K. J. *J. Am. Chem. Soc.* **1981**, *103*, 4186.
- (39) Alder, R. W., Personal Communication to G. R. Weisman.
- (40) Alder, R. W.; Eastment, P.; Moss, R. E.; Sessions, R. B.; Stringfellow, M. A. *Tetrahedron Lett.* **1982**, *23*, 4181.

- (41) Alder, R. W.; Sessions, R. B. *Tetrahedron Lett.* **1982**, *23*, 1121.
- (42) Alder, R. W.; Heilbronner, E.; Honegger, E.; McEwen, A. B.; Moss, R. E.; Olefirowicz, E.; Petillo, P. A.; Sessions, R. B.; Weisman, G. R.; White, J. M.; Yang, Z.-Z. *J. Am. Chem. Soc.* **1993**, *115*, 6580.
- (43) Dietrich, B.; Viout, P.; Lehn, J.-M. *Macrocyclic Chemistry*; VCH: Weinheim, 1993.
- (44) Duhamel, L. In *Supplement F: The Chemistry of Amino, Nitroso and Nitro Compounds and their Derivatives*; Patai, S., Ed.; John Wiley and Sons: New York, 1982; Vol. 2, p Chapter 20.
- (45) Jazwinski, J.; Kolinski, R. A. *Bull. Pol. Acad. Sci.* **1988**, *36*, 215.
- (46) Jazwinski, J.; Kolinski, R. A. *Tetrahedron Lett.* **1981**, *22*, 1711.
- (47) Muller, R.; Philipsborn, W.; Schleifer, L.; Aped, P.; Fuchs, B. *Tetrahedron* **1991**, *47*, 1013.
- (48) Fuchs, B.; Ellencweig, A. *Recl. Trav. Chim. Pays-Bas* **1979**, *98*, 326.
- (49) Gautier, J.-A.; Miocque, M.; Farnoux, C. C. In *The Chemistry of Amidines and Imidates*; Patai, S., Ed.; John Wiley and Sons: New York, 1975; Vol. 1, p 283.
- (50) Kantlehner, W. In *Iminium Salts in Organic Chemistry, [Adv. Org. Chem.: Methods and Results, E. C. Taylor (Series Ed.)]*; Boehme, H., Viehe, H. G., Eds.; John Wiley and Sons: New York, 1979; Vol. 9 part 2, p 279.
- (51) Forssell, G. *Chem. Ber.* **1891**, *24*, 1846.
- (52) Lehr, H.; Erlenmeyer, H. *Helv. Chim. Acta* **1944**, *27*, 489.
- (53) Wang, J. C.; Bauman, J. E. *J. Inorg. Chem.* **1965**, *4*, 1613.
- (54) Hurd, R. N.; Delamater, G. *Chem. Rev.* **1961**, *61*, 45.
- (55) Reggel, L.; Henry, J. P.; Wender, I. *J. Org. Chem.* **1961**, *26*, 1837.
- (56) Wotiz, J. H.; Kleopfer, R. D.; Barelski, P. M.; Hinckley, C. C.; Koster, D. F. *J. Org. Chem.* **1972**, *37*, 1758.
- (57) Woodburn, H. M.; O'Gee, R. C. *J. Org. Chem.* **1952**, *17*, 1235.
- (58) Woodburn, H. M.; Fisher, J. R. *J. Org. Chem.* **1957**, *22*, 895.
- (59) Weidinger, H.; Kranz, J. *Chem. Ber.* **1964**, *97*, 1599.
- (60) Sandnes, R. W.; Vasilevskis, J.; Undheim, K.; Gacek, M.; Nycomed

Imaging A/s Norway: PCT Int. Appl. WO 96 28,432, 19 Sept 1996; *Chem. Abstr.* **1996**, 125: 301031c

- (61) Weisman, G. R.; Reed, D. P. *J. Org. Chem.* **1996**, 61, 5186-5187.
- (62) Wang, J. C. Ph.D. Dissertation, University of Missouri, Columbia, Missouri, 1964.
- (63) Bauman, J. E., Personal Communication to G. R. Weisman, Nov. 1996.
- (64) Chabrier, P.; Renard, S. H. *Compt. Rend.* **1950**, 230, 1673.
- (65) The Immediately Dangerous to Life and Health Value (IDLH) for H₂S is 300 ppm as given in *Hazardous Chemicals Data Book*, Weiss, G. Ed.; Noyes Data Corp.: Park Ridge, New Jersey; 2nd ed. The IDLH value is the maximum level one could escape within 30 min. without serious irreversible health effects.
- (66) Correction: Weisman, G. R.; Reed, D. P. *J. Org. Chem.* **1997**, 62, 4548.
- (67) Fieser, L. F.; Fieser, M. *Reagents for Organic Synthesis*; John Wiley and Sons: New York, 1967; Vol. 1.
- (68) Reed, D. P.; Weisman, G. R. *Org. Synth.* **currently under checking procedure.**
- (69) Swinkles, D. W.; van Duynhoven, J. P. M.; Hilbers, C. W.; Tesser, G. I. *Recl. Trav. Chim. Pays-Bas* **1991**, 110, 124.
- (70) Hérve, G.; Bernard, H.; LeBris, N.; Yaouanc, J.-J.; Handel, H.; Toupet, L. *Tetrahedron Lett.* **1998**, 39, 6861.
- (71) Hung, Y. *Inorg. Synth.* **1980**, 20, 105.
- (72) Baker, D. A.; Armen, H. G.; Funaro, S. *J. Chem. Soc., Dalton Trans.* **1983**, 2519.
- (73) Heininger, A. *J. Org. Chem.* **1957**, 22, 1213.
- (74) Brown, H. C.; Subba Rao, B. C. *J. Am. Chem. Soc.* **1986**, 78, 2582.
- (75) Pinner, A.; Klein, F. *Chem. Ber.* **1887**, 10, 1889.
- (76) Pinner, A. In *Die Imidoather und ihre Derivate*; Oppenheim: Berlin, 1892.
- (77) Janz, G. J. *Inorg. Synth.* **1957**, 5, 43.
- (78) Webster, O. W.; Hartter, D. R.; Begland, R. W.; Sheppard, W. A.; Cairncross, A. *J. Org. Chem.* **1972**, 37, 4133.
- (79) Begland, R. W.; Hartter, D. R. *J. Org. Chem.* **1972**, 37, 4130.

- (80) Kantlehner, W.; Dinkeldein, U.; Brederbeck, H. *Leibigs Ann. Chem.* **1979**, 1346.
- (81) Bock, H.; Ruppert, K.; Merzweiler, K.; Fenske, D.; Goesmann, H. *Angew. Chem., Int. Ed. Eng.* **1989**, 28, 1684.
- (82) Shi, Z.; Thummel, R. P. *J. Org. Chem.* **1995**, 60, 5935.
- (83) Roechling, H. *Z. Naturforsch., B: Chem. Sci.* **1970**, 25, 931.
- (84) Shionogi and Co. Ltd. JP 7031941, 1970; CA 74: 11205b.
- (85) Fieselmann, B. J.; Hendrickson, D. N.; Stucky, G. D. *Inorg. Chem.* **1978**, 17, 2078.
- (86) Duranti, E.; Balsamini, C. *Synthesis* **1974**, 815.
- (87) Aqra, F. M. A. M.; Shah, S. A.; Jamhour, R. M. A. Q. *Synth. React. Inorg. Met. -Org. Chem.* **1994**, 24, 1599.
- (88) Wei, J. F.; Zhuo, R. X.; Yan, G. P.; Du, P. *Chemical Journal of Chinese Universities* **1997**, 18, 658.
- (89) Hines, M. S. Thesis, University of New Hampshire, 1997.
- (90) Guggisberg, A.; Kramer, U.; Heidelberger, C.; Charubala, R.; Stephanou, E.; Hesse, M.; Schmid, H. *Helv. Chim. Acta* **1978**, 61, 1050.
- (91) Hesse, M. *Transamidation Reactions*; In *Ring Enlargement in Organic Chemistry*, VCH: New York, 1991, pg 97.
- (92) Kramer, U.; Guggisberg, A.; Hesse, M.; Schmid, H. *Angew. Chem., Int. Ed. Eng.* **1978**, 17, 200.
- (93) Gould, J. W. M. S. Thesis, University of New Hampshire, 1983.
- (94) For Reviews on 1,4-diaza-1,3-butadiene systems see: (a) Lora-Tamayo, M.; Soto, J. L. In *1,4-Cycloaddition Reactions, The Diels-Alder Reaction in Heterocyclic Synthesis*; Hamer, J., Ed.; Academic Press: New York, 1967; Vol. 8, p 183. (b) Boger, D. L.; Weinreb, S. M. *Hetero Diels-Alder Methodology in Organic Synthesis*; Academic Press: New York, 1987; p 274.
- (95) Wiberg, N. *Angew. Chem., Int. Ed. Eng.* **1968**, 7, 766.
- (96) Sauer, J.; Wiest, H.; Mielert, A. *Chem. Ber.* **1964**, 97, 3183.
- (97) Wainwright, K. P. *Inorg. Chem.* **1980**, 19, 1396.
- (98) Ramasubba, A.; Wainwright, K. P. *J. Chem. Soc., Chem. Commun.* **1982**, 277.

- (99) Busch, D. H. *Acc. Chem. Res.* **1978**, *11*, 392.
- (100) Smierciak, R.; Passariello, J.; Blinn, E. L. *Inorg. Chem.* **1977**, *16*, 2646.
- (101) Weisman, G. R.; Rogers, M. E.; Wong, E. H.; Jasinski, J. P.; Paight, E. S. *J. Am. Chem. Soc.* **1990**, *112*, 8604.
- (102) Bencini, A.; Bianchi, A.; Bazzicalupi, C.; Ciampolini, M.; Fusi, V.; Micheloni, M.; Nardi, N.; Paoli, P.; Valtancoli, B. *Supramolecular Chem.* **1994**, *3*.
- (103) Hill, D. C. Ph.D. Dissertation, University of New Hampshire, 1995.
- (104) Weisman, G. R.; Wong, E. H.; Hill, D. C.; Rogers, M. E.; Reed, D. P.; Calabrese, J. C. *J. Chem. Soc., Chem. Commun.* **1996**, 947-948.
- (105) Weisman, G. R.; Ho, S. C.-H.; Johnson, V. B. *Tetrahedron Lett.* **1980**, 335.
- (106) Alder, R. W.; Bowman, P. S.; Steele, W. R. S.; Winterman, D. R. *J. Chem. Soc., Chem. Commun.* **1968**, 723.
- (107) Koppel, I.; Koppel, J.; Pihl, V. *Org. React. (Tartu)* **1987**, *24*, 387.
- (108) Bradshaw, J. E.; Krakowiak, K. E.; Izatt, R. M. *Tetrahedron* **1992**, *48*, 4475.
- (109) Tsukube, H.; Adachi, H.; Morosawa, S. *J. Org. Chem.* **1991**, *56*, 7102.
- (110) Tsukube, H.; Adachi, H.; Morosawa, S. *J. Chem. Soc., Perkin Trans. 1* **1989**, 1537.
- (111) Katakya, R.; Matthes, K. E.; Nicholson, P. E.; Parker, D.; Buschmann, H. *J. J. Chem. Soc., Perkin Trans. 2* **1990**, 1425.
- (112) Rappoport, Z. *Acc. Chem. Res.* **1981**, *14*, 7.
- (113) Murase, I.; Mikuria, M.; Sonoda, H.; Kida, S. *J. Chem. Soc., Chem. Commun.* **1984**, 692.
- (114) Murase, I.; Mikuria, M.; Sonoda, H.; Fukuda, Y.; Kida, S. *J. Chem. Soc., Dalton Trans.* **1986**, 953.
- (115) Dietrich, B.; Hosseini, M. W.; Lehn, J.-M.; Sessions, R. B. *Helv. Chim. Acta.* **1985**, *68*, 289.
- (116) Weisman, G. R., Personal Communication, 1998.
- (117) Wong, E. H.; Weisman, G. R. *Proposal to The National Institutes of Health* **1996**.

- (118) Miller, J. *Aromatic Nucleophilic Substitution*; Elsevier Publishing Co: Amsterdam, 1968.
- (119) March, J. *Advanced Organic Chemistry*; 4th ed.; John Wiley and Sons: New York, 1992.
- (120) Sutherland, I. O. In *Crown Compounds: Towards Future Applications*; Cooper, S. R., Ed.: VCH: New York, 1992, p 246.
- (121) Lohr, H. G.; Vögtle, F. *Acc. Chem. Res.* **1985**, *18*, 65.
- (122) Takagi, M.; Ueno, K. *Top. Curr. Chem.* **1984**, *121*, 39.
- (123) Sanger, F. *Biochem. J.* **1949**, *45*, 563.
- (124) Wagaw, S.; Rennels, R. A.; Buchwald, S. L. *J. Am. Chem. Soc.* **1997**, *119*, 8451.
- (125) Wolfe, J. P.; Wagaw, S.; Buchwald, S. L. *J. Am. Chem. Soc.* **1996**, *118*, 7215.
- (126) Louie, J.; Hartwig, J. F.; Fry, A. J. *J. Am. Chem. Soc.* **1997**, *119*, 11695.
- (127) Heaney, H. *Chem. Rev.* **1962**, *62*, 81.
- (128) Huisgen, R.; Sauer, J. *Chem. Ber.* **1958**, *93*, 1453.
- (129) Budzelaar, P. H. M. gNMR: Program for Spectral Simulation. Cherwell Scientific Publishing Limited, Oxford; v 3.6.
- (130) *Lithium-Current Applications in Science, Medicine and Technology*; Bach, R. O., Ed.; Wiley-Interscience: New York, 1985.
- (131) Olsher, U.; Izatt, R. M.; Bradshaw, J. S.; Dalley, N. K. *Chem. Rev.* **1991**, *91*, 137.
- (132) Schou, M. In *Lithium and the Cell: Pharmacology and Biochemistry*; Birch, N. J., Ed.; Academic Press: London, 1991.
- (133) *Lithium: Inorganic Pharmacology and Psychiatric Use*; IRL Press: Oxford, 1988.
- (134) Bach, R. O. *Med. Hypotheses* **1987**, *23*, 157.
- (135) Zeevi, A.; Margalit, R. *J. Membr. Biol.* **1991**, *121*, 133.
- (136) Buhlmann, P.; Pretsch, E.; Bakker, E. *Chem. Rev.* **1998**, *98*, 1593.
- (137) Gadzekpo, V. P. Y.; Hungerford, J. M.; Kadry, A. M.; Ibrahim, Y. A.; Xie, R. Y.; Christian, G. D. *Anal. Chem.* **1986**, *58*, 1948.

- (138) Bartsch, R. A.; Ramesh, V.; Bach, R. O.; Shono, T.; Kimura, K. In *Lithium Chemistry, A Theoretical and Experimental Overview*; Sapse, A.-M., Schleyer, P. v. R., Eds.; Wiley: New York, 1995, p 393.
- (139) Faulkner, S.; Katacky, R.; Parker, D.; Teasdale, A. *J. Chem. Soc., Perkin Trans. 2* **1995**, 1761.
- (140) Watanabe, K.; Nakagawa, E.; Yamada, H.; Hisamoto, H.; Suzuki, K. *Anal. Chem.* **1993**, *665*, 2704.
- (141) Metzger, E.; Ammann, D.; Asper, R.; Simon, W. *Anal. Chem.* **1986**, *58*, 132.
- (142) Pearson, R. G. *J. Am. Chem. Soc.* **1963**, *85*, 3533.
- (143) Pearson, R. G. *J. Chem. Educ.* **1968**, *45*, 581.
- (144) Marcus, Y. *Israel J. Chem.* **1972**, *10*, 659.
- (145) Wong, E. H., Personal Communication, 1998.
- (146) Hubin, T. J.; McCormick, J. M.; Collinson, S. R.; Alcock, N. W.; Busch, D. H. *J. Chem. Soc., Chem. Commun.* **1998**, 1675.
- (147) Taken from Reference 61: There has been a great deal of confusion about the mp of **2** in the literature. Stetter and Mayer²⁶ originally reported mp 35° C. Buøen *et al.* reported mp 119-120°C.¹⁵¹ Aldrich and Fluka list melting point ranges of 110-113° C (97%) and 105-110° C (≥97%) respectively in their catalogs. Confusing matters further, Zhang and Busch¹⁵² subsequently reported mp 36-38° C. Our mp range for **2** (calibrated thermometer) is lower than that reported in reference 26, but is consistent with the mp range of sublimed material (no detectable impurities by high S/N NMR) we have prepared by the Richman-Atkins method (mp 105-109° C). ¹H NMR relative integrations of the material reported were consistent with anhydrous **2**.
- (148) There are various reported melting points for **11** in the literature: Reference 51: 289-291 °C; Reference 55: ~300 °C; Reference 56: 305-310 °C; Reference 57: 289-291 °C; Reference 59: 297-299 °C.
- (149) Branholtz, J. T.; Mann, F. G. *J. Chem. Soc.* **1953**, 1817.
- (150) Caywood, G. A. B. S. Thesis, University of New Hampshire, 1980.
- (151) Buøen, S.; Dale, J.; Krane, J. *Acta Chem. Scand.* **1984**, *B38*, 773.
- (152) Zhang, R.; Busch, D. H. *Inorg. Chem.* **1993**, *32*, 4920.

IMAGE EVALUATION TEST TARGET (QA-3)

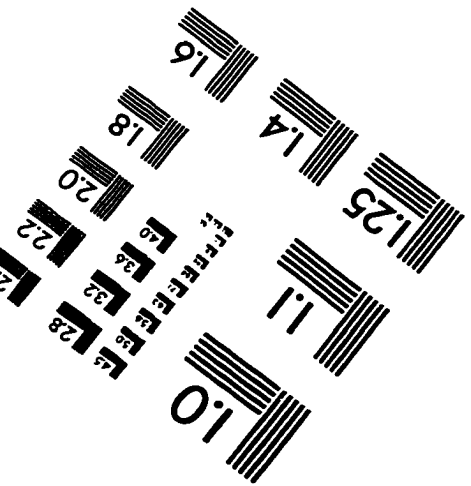
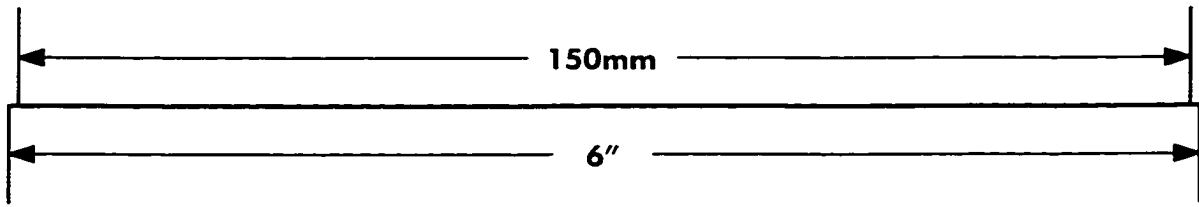
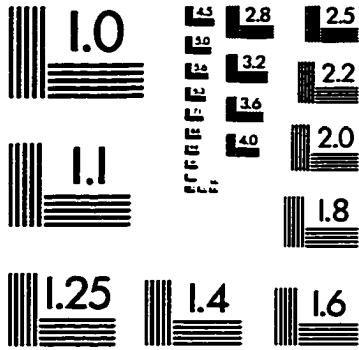
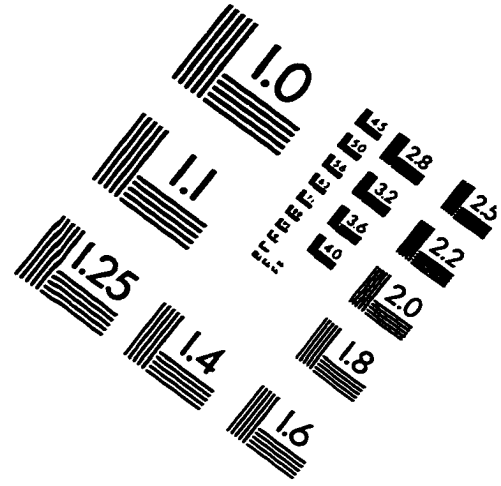
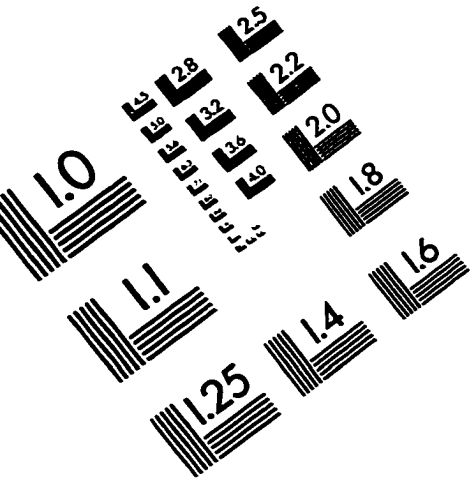

APPLIED IMAGE, Inc
1653 East Main Street
Rochester, NY 14609 USA
Phone: 716/482-0300
Fax: 716/288-5989

© 1993, Applied Image, Inc., All Rights Reserved

