

Fall 1974

CHARACTERIZATION OF LIMNETIC  
ZOOPLANKTON PHOSPHORUS  
EXCRETION AND FACTORS AFFECTING  
TEMPORAL EXCRETION RATES IN THE  
PHOSPHORUS CYCLE IN A LAKE

JOHN GEORGE FERRANTE

Follow this and additional works at: <https://scholars.unh.edu/dissertation>

---

**Recommended Citation**

FERRANTE, JOHN GEORGE, "CHARACTERIZATION OF LIMNETIC ZOOPLANKTON PHOSPHORUS EXCRETION AND FACTORS AFFECTING TEMPORAL EXCRETION RATES IN THE PHOSPHORUS CYCLE IN A LAKE" (1974).

*Doctoral Dissertations*. 1059.

<https://scholars.unh.edu/dissertation/1059>

This Dissertation is brought to you for free and open access by the Student Scholarship at University of New Hampshire Scholars' Repository. It has been accepted for inclusion in Doctoral Dissertations by an authorized administrator of University of New Hampshire Scholars' Repository. For more information, please contact [nicole.hentz@unh.edu](mailto:nicole.hentz@unh.edu).

## INFORMATION TO USERS

This material was produced from a microfilm copy of the original document. While the most advanced technological means to photograph and reproduce this document have been used, the quality is heavily dependent upon the quality of the original submitted.

The following explanation of techniques is provided to help you understand markings or patterns which may appear on this reproduction.

1. The sign or "target" for pages apparently lacking from the document photographed is "Missing Page(s)". If it was possible to obtain the missing page(s) or section, they are spliced into the film along with adjacent pages. This may have necessitated cutting thru an image and duplicating adjacent pages to insure you complete continuity.
2. When an image on the film is obliterated with a large round black mark, it is an indication that the photographer suspected that the copy may have moved during exposure and thus cause a blurred image. You will find a good image of the page in the adjacent frame.
3. When a map, drawing or chart, etc., was part of the material being photographed the photographer followed a definite method in "sectioning" the material. It is customary to begin photoing at the upper left hand corner of a large sheet and to continue photoing from left to right in equal sections with a small overlap. If necessary, sectioning is continued again -- beginning below the first row and continuing on until complete.
4. The majority of users indicate that the textual content is of greatest value, however, a somewhat higher quality reproduction could be made from "photographs" if essential to the understanding of the dissertation. Silver prints of "photographs" may be ordered at additional charge by writing the Order Department, giving the catalog number, title, author and specific pages you wish reproduced.
5. PLEASE NOTE: Some pages may have indistinct print. Filmed as received.

**Xerox University Microfilms**

300 North Zeeb Road  
Ann Arbor, Michigan 48106

75-45

FERRANTE, John George, 1945-  
CHARACTERIZATION OF LIMNETIC ZOOPLANKTON  
PHOSPHORUS EXCRETION AND FACTORS AFFECTING  
TEMPORAL EXCRETION RATES IN THE PHOSPHORUS  
CYCLE IN A LAKE.

University of New Hampshire, Ph.D., 1974  
Zoology

**Xerox University Microfilms**, Ann Arbor, Michigan 48106

© 1974

JOHN GEORGE FERRANTE

ALL RIGHTS RESERVED

**THIS DISSERTATION HAS BEEN MICROFILMED EXACTLY AS RECEIVED.**

CHARACTERIZATION OF LIMNETIC ZOOPLANKTON PHOSPHORUS  
EXCRETION AND FACTORS AFFECTING TEMPORAL EXCRETION RATES IN  
THE PHOSPHORUS CYCLE IN A LAKE

by

JOHN G. FERRANTE

B.S., Ashland College, 1967

M.S., University of New Hampshire, 1969

A THESIS

Submitted to the University of New Hampshire

In Partial Fulfillment of

The Requirements for the Degree of

Doctor of Philosophy

Graduate School

Department of Zoology

September, 1974

This thesis has been examined and approved.

*Philip J. Sawyer*

Thesis director, Philip J. Sawyer, Prof. of Zoology

*James F. Haney*

James F. Haney, Asst. Prof. of Zoology

*John J. Sasner*

John J. Sasner, Asso. Prof. of Zoology

*Francis R. Hall*

Francis R. Hall, Prof. of Hydrology, Institute of  
Natural and Environmental Resources

*Hugh Mulligan*

Hugh Mulligan, Asso. Prof. of Botany

*August 9, 1974*

Date

## ACKNOWLEDGEMENTS

The author expresses his sincere gratitude to his committee for their advice in the preparation of this manuscript. Special thanks are due Dr. James F. Haney whose advice during the gathering and analysis of data was invaluable.

I am grateful to Anne Packard for her assistance in the identification of phytoplankton samples and to Mark Mattson and Howard Katz for their assistance in the collection and analysis of samples.

The work described herein was supported in part by the United States Department of the Interior as authorized under the Water Resources Research Act of 1964, Public Law 88-379, through the Water Resources Research Center of the University of New Hampshire.

Sincere thanks are extended to Mr. Gordon Byers, director of the Water Resources Research Center who grasped the significance of this investigation and without whose administrative assistance this work could not have been completed.

I am especially thankful to my wife, Karen, and daughter, Melissa, for their perserverence through the duration of this research.

I am also indebted to Claudia Darling for the typing and editing of this thesis.

TABLE OF CONTENTS

LIST OF FIGURES.....v

LIST OF TABLES.....vii

ABSTRACT.....viii

I. INTRODUCTION.....1

II. STUDY AREA.....6

III. METHODS AND MATERIALS.....9

    1. Temporal and Spatial Phosphorus Excretion Study....9

        a. Phosphorus analysis.....9

        b. Phosphorus uptake by seston.....13

        c. Zooplankton analysis.....14

        d. Lake parameters.....16

        e. Phytoplankton analysis.....16

        f. Phosphorus model.....16

    2. Phosphorus Characterization of Excretion Products..18

        a. Gel filtration (molecular weight  
            characterization).....19

        b. Seston incorporation of excretion products....20

        c. Ultraviolet spectroscopy.....20

IV. RESULTS

    1. Temporal and Spatial Phosphorus Excretion Study....22

        a. Phosphorus observations.....22

        b. Water chemistry.....26

        c. Zooplankton.....28

        d. Phytoplankton.....31

        e. Phosphorus model.....31

2.	Phosphorus Characterization of Excretion	
	Products.....	34
	a. Zooplankton species analysis.....	34
	b. Seston incorporation of excretion products...	34
	c. Gel filtration studies.....	34
	d. Ultraviolet spectroscopy studies.....	38
V.	DISCUSSION	
1.	Studies on Temporal and Spatial Phosphorus	
	Excretion.....	39
2.	Phosphorus Characterization of Excretion	
	Products.....	51
	LITERATURE CITED.....	54



## LIST OF FIGURES

Number	Page
1.	Map of the northeast coast of the United States indicating the location of Stonehouse Pond in the State of New Hampshire, U.S.A.....7
2.	Morphometric map of Stonehouse Pond, New Hampshire, U.S.A. (Prepared by Ann Packard and the New Hampshire Water Supply and Pollution Commission).8
3.	Diagram of the collecting apparatus indicating the location of submersible pumps relative to the collecting platform and the lake strata.....10
4.	Diagram of the column used for the collection of zooplankton indicating the water level inside the column and the arrangement of the collecting nets Net (a) is 0.308 mm and (b) 1.05 mm mesh Nitex plankton net.....11
5.	Phosphorus excretion rates of zooplankton in the > 0.308 (----) and < 0.308 (----) size groups collected in the epilimnion of Stonehouse Pond, New Hampshire from August 7, 1972 to July 18, 1973..23
6.	Phosphorus excretion rates of zooplankton in the > 0.308 (----) and < 0.308 mm (----) size groups collected in the hypolimnion of Stonehouse Pond, New Hampshire from August 7, 1972 to July 18, 1973.....24
7.	Soluble reactive phosphorus levels in the epilimnion and hypolimnion of Stonehouse Pond, New Hampshire from August 7, 1972 to July 18, 1973, Epilimnion (-----), Hypolimnion (-----).....27
8.	Percent composition of <u>Daphnia</u> , <u>Diaptomus</u> and <u>Cyclops</u> in the epilimnion and hypolimnion of Stonehouse Pond, New Hampshire from August 16, 1972 to July 18, 1973. The left half of each column indicates epilimnion composition, right half hypolimnion.....30
9.	Seasonal pattern of phytoplankton numbers in the epilimnion (----) and hypolimnion (----) of Stonehouse Pond, New Hampshire from August 16, 1972 to July 18, 1973.....33
10.	Uptake curve of $^{32}\text{P}$ -labelled zooplankton excretion (A) and $^{32}\text{P-PO}_4$ (B) by natural seston on July 3, 1974. (curves fitted by eye).....35

11.	Sephadex gel filtration curve of $^{32}\text{P-PO}_4$ and $^{32}\text{P}$ -labelled zooplankton excretion.....	37
12.	The compartmental model of the biological phosphorus cycle.....	43

## LIST OF TABLES

Number	Page
1.	Length-weight relationship of zooplankton collected in Stonehouse Pond, New Hampshire.....15
2.	Maximum and minimum rates of zooplankton phosphorus excretion in the epilimnion and hypolimnion for 0.308 and < 0.308 mm size groups.....25
3.	Species of zooplankton collected in Stonehouse Pond, New Hampshire from August 16, 1972 to July 19, 1973.....29
4.	Phytoplankton genera collected in the epilimnion and hypolimnion of Stonehouse Pond, New Hampshire from August 16, 1972 to July 19, 1973.....32
5.	Turnover time of $^{32}\text{P-PO}_4$ and $^{32}\text{P}$ -labelled zooplankton excretions by natural seston, spring 1974. Time expressed in minutes.....36
6.	Mass balance equations indicating the movement of phosphorus in lake water.....45
7.	Net phosphorus content of $\text{PO}_4$ , zooplankton and seston compartment in Stonehouse Pond on February 22, April 6, May 17, and June 20, 1973.....47
8.	Rates of phosphorus movement between compartments of a phosphorus cycle constructed for February 22, April 6, May 17, and June 20, 1973 .....49

## ABSTRACT

### CHARACTERIZATION OF LIMNETIC ZOOPLANKTON PHOSPHORUS EXCRETION AND FACTORS AFFECTING TEMPORAL EXCRETION RATES IN THE PHOSPHORUS CYCLE IN A LAKE

by

JOHN G. FERRANTE

The temporal and spatial excretion rates of specific size groups of limnetic zooplankton were studied by measuring changes in soluble reactive phosphorus following incubation. Animals were collected in the epilimnion and hypolimnion of Stonehouse Pond, New Hampshire from August, 1972 to July, 1973 and separated into  $> 0.308$  and  $< 0.308$  millimeters (mm) size groups.

Temporal excretion rates varied considerably within groups, however, similar patterns were observed in both strata. Peak excretion rates were observed in the spring and fall and a low rate in winter months. In addition, smaller animals excreted at higher rates and the excretion rates of both size groups in the epilimnion exceeded those in the hypolimnion.

The phosphorus uptake of natural seston relative to the amount released by zooplankton is considered using mass balance equations and kinetic analysis. During the spring

of 1973 excretion rates increased, however, this increase was offset by an even greater increase in the rate of phosphorus uptake by the seston. This suggests that during this period the phosphorus excretions of zooplankton were not sufficient to meet the amount of phosphorus being removed by the seston.

The characteristics of phosphorus excretions of zooplankton collected in the spring of 1974 were studied in gel filtration, ultraviolet spectroscopy and seston incorporation studies. The soluble phosphorus component released from a natural population has a molecular weight the same as orthophosphate and behaves similarly in seston incorporation studies. Approximately 15 percent of the total phosphorus released is organic, but could not be identified by ultraviolet spectroscopy. No evidence of nucleic acid excretion or any hydrolytic degradation product was detected in the ultraviolet spectrum.

## I. INTRODUCTION

Field and laboratory studies with  $^{32}\text{PO}_4$  indicate a dynamic movement of phosphorus between zones within a lake and phosphorus compartments in lake water. The movement of phosphorus between the littoral, benthic and limnetic zones described by Rigler (1956) and Chamberlain (1968) prompted Lean (1973a, 1973b) to focus more closely on the phosphorus exchange mechanisms within the open water between the compartments:  $\text{PO}_4$ , seston and colloids. Considerable effort has also been spent on excretion of phosphorus by aquatic animals (Pomeroy, Mathews and Min, 1963; Johannes, 1964b; Barlow and Bishop, 1965; Martin, 1968; Peters, 1972; Peters and Lean, 1973; Peters and Rigler, 1973; and Ganf and Blazka, 1974) yet the calculated excretion rates vary considerably. Most of the field studies have been short term in the summer and fall and little is known about the rates of phosphorus release during the remainder of the year. Additional data are needed in those periods of the year which have not been extensively included in previous studies. Radiotracer work in the laboratory by Rigler (1961), Peters (1972) and Peters et al., (1973) show closer agreement than field data but were conducted under controlled conditions and are limited to several species of Cladocera and Copepoda.

Various environmental and physical factors have been considered as having an effect upon the rate of phosphorus

release. Among these are temperature, salinity, and bacterial activity (Hargave and Geen, 1968); size of the zooplankton (Johannes, 1964a; Barlow et al., 1965); food supply (Butler et al., 1969) and nonuniform labelling during radiotracer studies or reuptake of excreted products during long incubation experiments (Peters et al., 1973).

Strong evidence has also indicated that the phosphorus excretion product of certain zooplankton is almost entirely orthophosphate (Rigler, 1961; Peters, 1972; and Peters et al., 1973). A review of the analytical procedures used for phosphate determination of previous field studies indicates that the most commonly used was the molybdenum reduction with stannous chloride or some other similar agent. Sources of error in this method due to the hydrolysis of labile phosphorus esters and arsenic interference are discussed by Rigler (1973). Chamberlain and Shapiro (1969) describe a modification of an extraction technique by Shapiro, Chamberlain and Barrett (1969) superior to three other methods tested when compared to a bioassay. Also, their extraction procedure eliminates or minimizes arsenic and hydrolysis problems.

To date most attempts to indicate the significance of zooplankton phosphorus excretion to phytoplankton phosphorus utilization have relied on an assumed carbon-phosphorus ratio which according to Strickland (1960) is unreliable due to the variability. Also, the  $^{14}\text{C}$  method used in these studies to calculate primary production may also be subject

to error due to the retention of dissolved compounds by membrane filters (Nalewajko and Lean, 1972) and cell damage during filtration (Arthur and Rigler, 1967).

Most previous investigators have examined the utilization of phosphorus excretions by algae with little regard for bacteria and detritus. Through the use of mass balance equations and kinetic analyses I have considered all three of these seston components in phosphorus studies.

The present study provides excretion data for different size zooplankton over a period of 12 months. It includes factors which may affect phosphorus excretion by the zooplankton community and phosphorus release in both the epilimnion and hypolimnion. A compartmental model is presented which includes the rate of phosphorus exchange by the seston compartment, grazing rates of zooplankton, phosphorus excretion rates of zooplankton, soluble reactive phosphorus levels in lake water and total phosphorus in particulate (minus zooplankton) and zooplankton fractions. The model is used to indicate the amount of phosphorus released by zooplankton relative to the utilization of the lake seston.

It has been shown that some algal species can hydrolyze polyphosphates by increased production and activity of alkaline phosphatase (Fitzgerald and Nelson, 1966). Although this activity may be significant at times, the major form of phosphorus utilized by algae and other constituents of natural lake seston is inorganic orthophosphate. The amount of phosphorus released by zooplankton



has been studied but, the form of the excretion products has received little attention.

Rigler (1961) indicated that the soluble release product of Daphnia magna is inorganic phosphate. More recent work by Peter et al., (1973) with  $^{32}\text{PO}_4$ , anion exchange, gel filtration and kinetic analysis confirmed that orthophosphate is the major form of phosphorus released by Daphnia rosea and Diaptomus minutus. Additional work on natural populations of zooplankton is being done in Europe by Peters (personal communication). Some previous investigators have indicated that over 50 percent of the phosphorus release product of zooplankton studied was soluble organic phosphorus (Pomeroy, Mathews and Min, 1963; Hargave and Geen, 1968). The obvious contradiction may be the result of rapid incorporation of released orthophosphate product by lake seston and its subsequent conversion to an organic form. This conversion of phosphorus from inorganic to organic form would be especially significant in long term experiments because excretion of the inorganic form would be underestimated and that of the organic overestimated. Therefore, the ecological role of zooplankton excretion products cannot be assessed until the form of the product is adequately characterized.

By using excretion products collected from a natural assemblage of limnetic zooplankton, a more conclusive characterization of the phosphorus products released in a lake has been made. The use of natural zooplankton and

seston stocks from the experimental lake is stressed in order to more accurately characterize the actual products released by the zooplankton under lake conditions.

Fig. 1. Map of the northeast coast of the United States indicating the location of Stonehouse Pond in the state of New Hampshire, U.S.A.

## II. STUDY AREA

Zooplankton excretion data was collected from August 16, 1972 to July 18, 1973 in Stonehouse Pond located in southeastern New Hampshire, U.S.A. (Fig. 1). The lake has a surface area of 5.9 hectares (ha) and a maximum depth of 15.2 meters (m) (Fig. 2). It has a small watershed and is surrounded by a mixed deciduous and coniferous forest. Because of the steep sloping surrounding area and the ground cover, runoff is limited to a short period in the spring and early summer. During midsummer and fall the water level is probably maintained by ground water and rainfall. The state of New Hampshire maintains a trout population in the lake with annual plantings of fingerlings and 10-25 centimeter (cm) brook trout.

Thermal stratification usually begins in April and continues into the fall. During this period the thermocline is well defined and varies between 1 and 2 m in thickness and is located between 3 to 7 m from the surface.

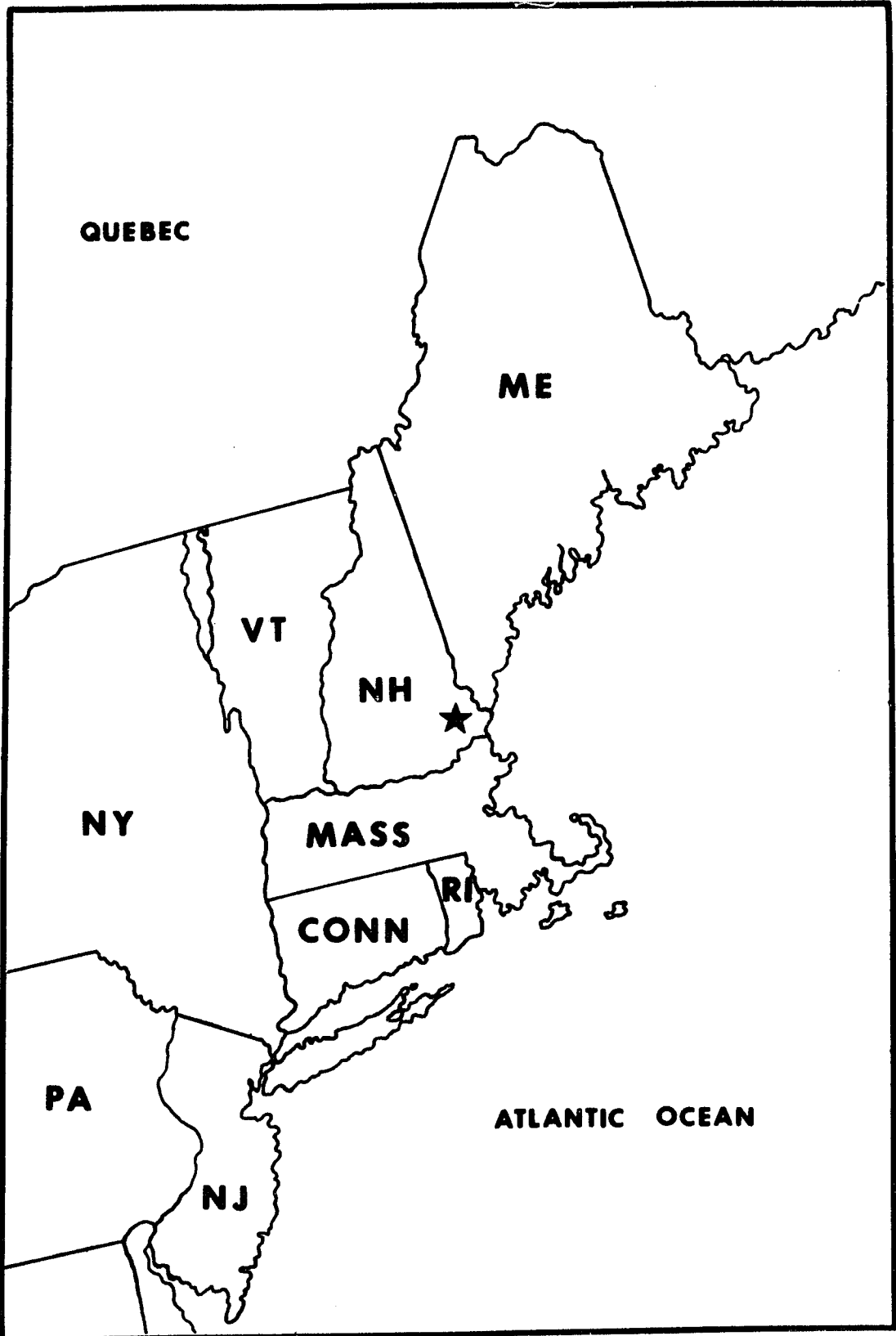
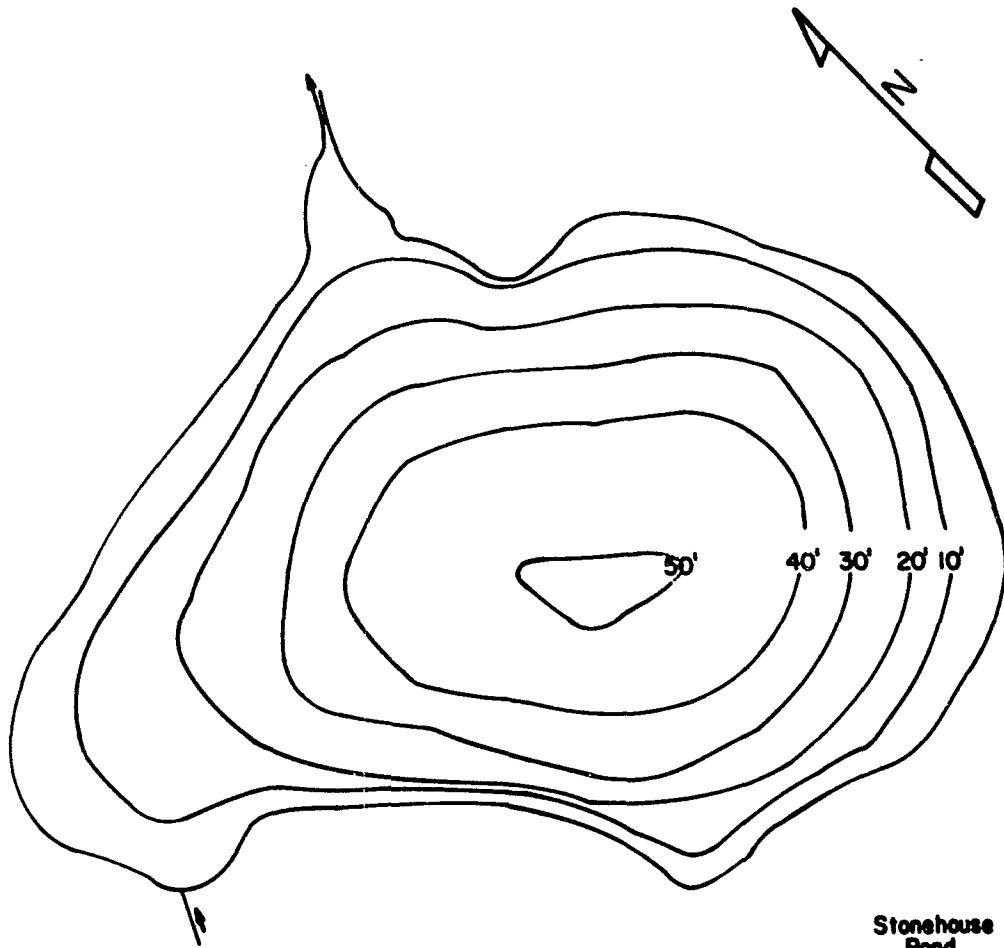

Fig. 2. Morphometric map of Stonehouse Pond, New Hampshire,  
U.S.A. (Prepared by Ann Packard and the New Hampshire  
Water Supply and Pollution Control Commission).



Stonehouse  
Pond  
Barrington, New Hampshire  
0 100 200 300  
Scale in Feet  
Contour interval. 10 Feet

Water Level  
2' Top of concrete-Batter Board  
Elevation 392 - USCG  
Mag. Decl. 15.5°

2-18-71 Surveyed  
2-19-71 Sounded  
Anne Packard  
Robert Estabrook  
Kenneth MacDonald

### III. METHODS AND MATERIALS

#### Temporal and Spatial Phosphorus Excretion Study

A platform for sample collection was situated in the central basin of the lake in approximately 14.0 m of water. Simultaneous collections of zooplankton were made from the epilimnion and hypolimnion with two submersible pumps located 6 to 7 m from the raft toward the sun (Fig. 3). The epilimnion pump was maintained at 1 m while that in the hypolimnion varied in depth from 3.5 to 8.0 m according to the location of the thermocline. Water from each stratum was pumped into the center of two concentric nitex nets suspended in water-filled columns, the outflow of which was located so that the entire net except the ring was submerged (Fig. 4). The mesh size of the central and outer nets were 1.05 and 0.308 mm respectively. Those animals collected in the central net were  $> 1.05$  and those in the outer  $< 1.05$  but  $> 0.308$  mm in length. A third group,  $< 0.308$  mm was collected with a continuous flow centrifuge. The centrifuge speed was regulated by a rheostat to achieve maximum separation efficiency and minimum physical damage to the animals. In further discussion these size fractions will be referred to as 1.05, 0.308, and  $< 0.308$  mm respectively.

#### Phosphorus Analysis

The zooplankton concentrations of each size group were diluted to 1000 milliliters (ml) with centrifuge effluent,



Fig. 3. Diagram of the collecting apparatus indicating the location of submersible pumps relative to the collecting platform and lake strata.

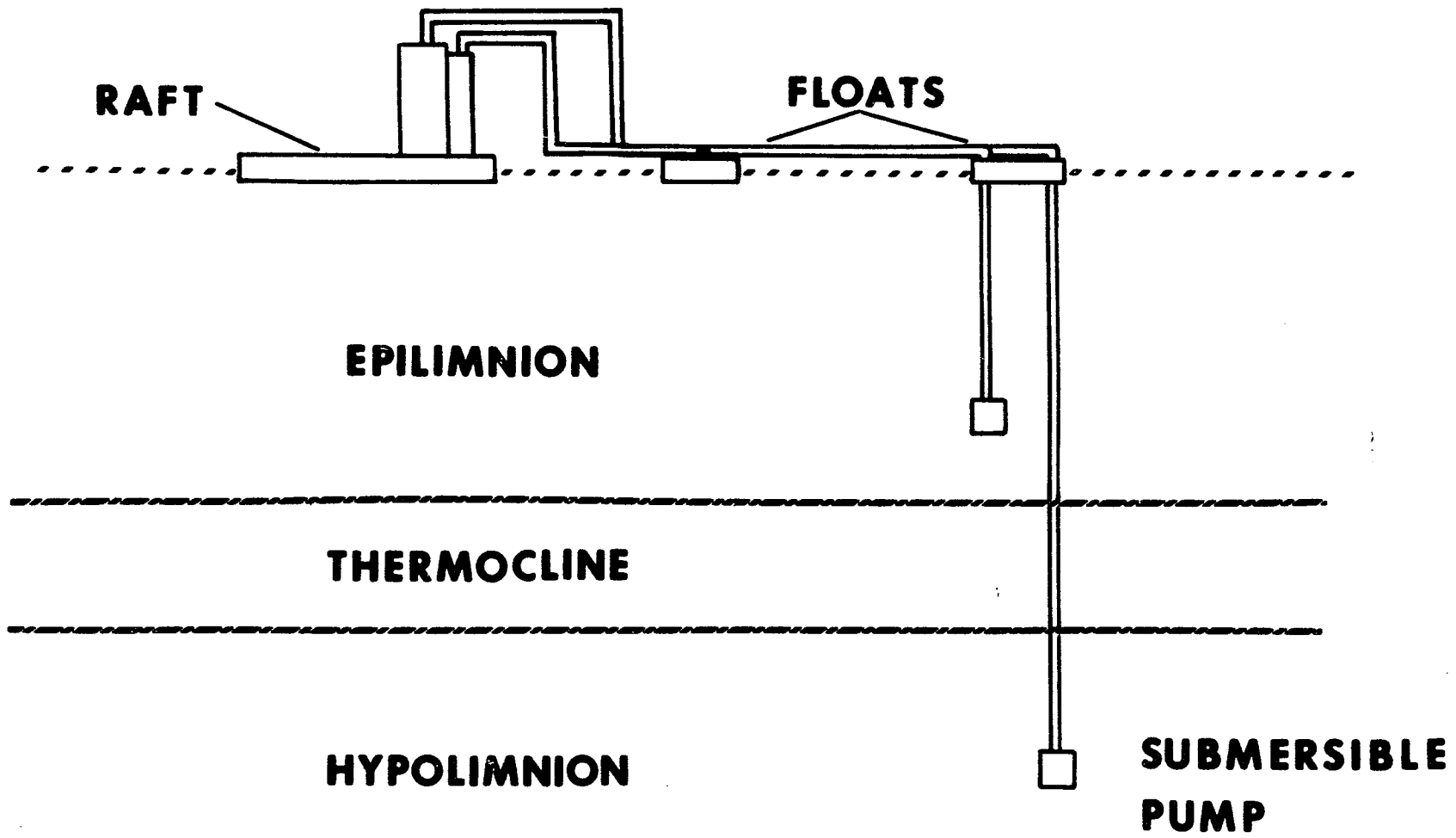
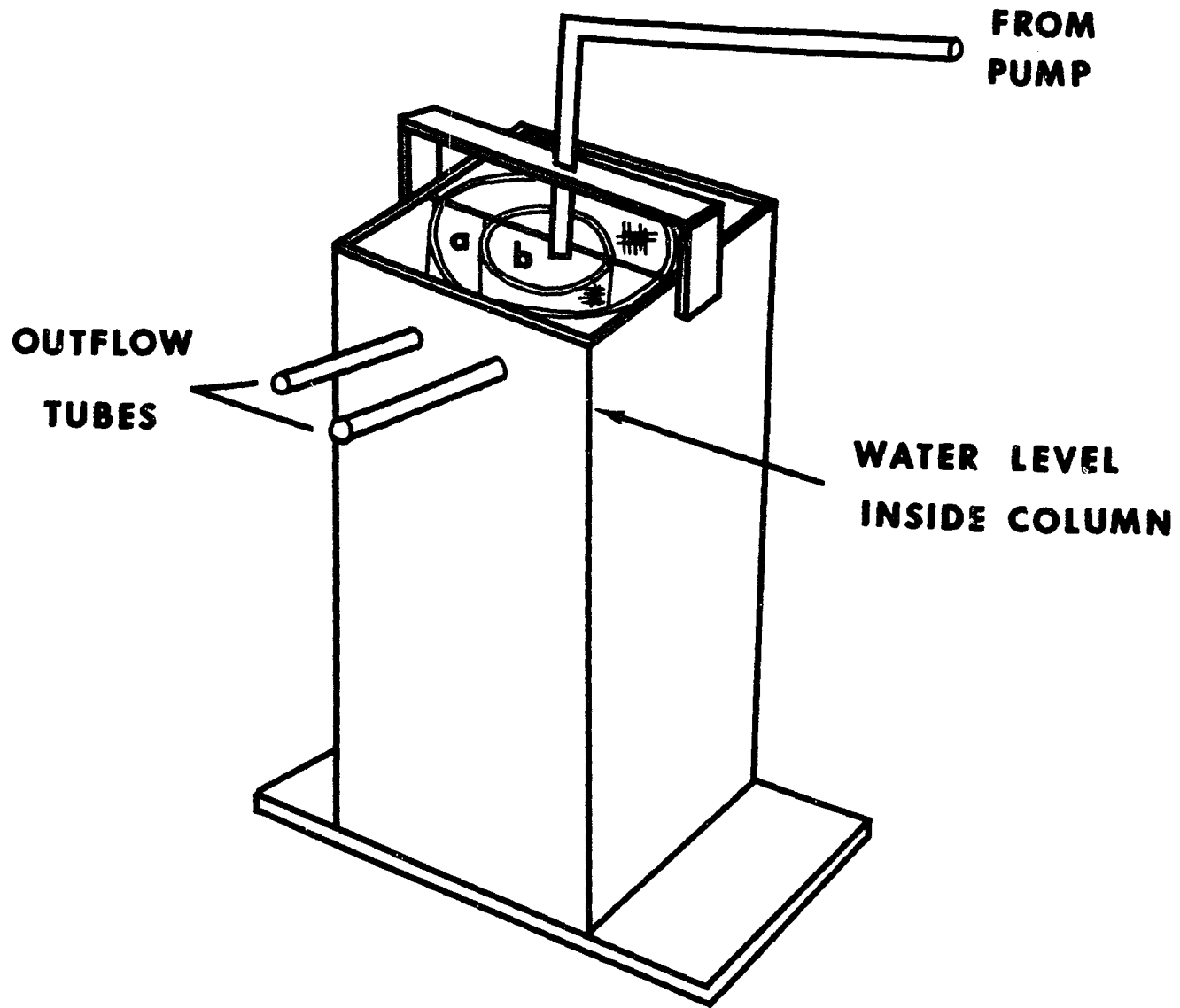

Fig. 4. Diagram of the column used for the collection of zooplankton indicating the water level inside the column and the arrangement of the collecting nets. Net (a) is 0.308 mm and (b) 1.05 mm mesh Nitex plankton net.



divided equally and placed into replicate 500 ml wide mouth bottles for incubation. Water was removed from the sample jars before incubation and analysed for soluble reactive phosphorus (SRP) according to Chamberlain and Shapiro (1969). This extraction method can be done quickly in the field (Shapiro, 1973), eliminates molybdoarsenic acid interference, gives the best estimate of actual phosphate concentrations in natural lake water (Rigler, 1973).

Samples of centrifuge effluent were placed in jars and treated the same as experimental samples. These were considered experimental controls and the SRP levels were subtracted from the experimental determinations.

Incubation was done in darkness and the temperature of the jars maintained as close to ambient temperature as possible. Incubation time varied since it included preparation of zooplankton for incubation and actual extraction. Maximum incubation time was one hour.

Pre- and post-incubation water samples were removed from the experimental and control bottles and SRP extracted in the field. The treated samples were returned to the laboratory, reduced with ascorbic acid and the absorbance of the molybdate complex at 885  $\mu\text{m}$  determined by a spectrophotometer. This wavelength permitted maximum molybdate and minimum humic acid absorbance. The concentration of SRP was extrapolated from standard curves previously prepared using potassium dihydrogen orthophosphate (American Public Health, Association, 1971). Since less than 10

percent of the zooplankton died during the short incubation period, SRP released from the breakdown of dead animals was minimal (Cooper, 1935), and the SRP increase was assumed to be the result of zooplankton excretion.

In addition to SRP, soluble unreactive phosphorus (SUP) and particulate phosphorus (PP) levels were also determined in all experimental water before and after incubation. Lake water was also collected and prepared for SRP, SUP, and PP analysis. The SUP and PP determinations were done according to Menzel and Corwin (1965) and Strickland and Parsons (1968) respectively.

#### Phosphorus Uptake by Seston

Water was collected from the hypolimnion and epilimnion and returned to the laboratory for phosphorus uptake studies. Three liters of the water from each stratum were placed in separate beakers and the temperature regulated by a water bath and maintained within  $2-3^{\circ}\text{C}$  of the ambient lake temperature at the sampling time. From 5 to 10 microcuries ( $\mu\text{c}$ ) of carrier-free  $^{32}\text{PO}_4$  in 0.02 N HCl (New England Nuclear) was thoroughly mixed into the water and 5 ml samples removed at various time intervals. The first four to five samples were removed within one minute of the time of isotope introduction. The remaining samples were removed at various time intervals up to 1.5 hours after isotope introduction. These samples were filtered through pre-washed Millipore filters ( $.45 \mu$ ) and the activity of the

filtrate counted by liquid scintillation and plotted as cpm's vs time. The turnover rates of  $^{32}\text{PO}_4$  by the seston were calculated according to Zilversmit, Entenen and Fishler, (1943).

#### Zooplankton Analysis

Zooplankton were separated from the incubation water, preserved in 10 percent buffered formalin and 40 gr  $\text{l}^{-1}$  sucrose (Haney and Hall, 1973). The entire sample was placed in a gridded petri dish, the animals identified and counted. When many animals were collected, only five random squares (10 percent) of the sample were counted. The average number of zooplankton per square was then used to calculate the total number in the sample. An analysis of variance indicated no significant difference between squares randomly chosen in the dish.

Dry weight determinations for the zooplankton were extrapolated from genus specific length-weight relationships (Table 1). The curves were constructed with weights of unpreserved specimens prepared according to Lovegrove (1966). The dry weight of those animals which comprised the < 0.308 mm group was determined by either weighing (on a Cahn Electrobalance) large numbers of individuals or from values given in Nauwerk (1963). For estimates of food eaten by the zooplankton the percent composition of gut content was estimated from the volume of the dissected gut occupied by each component. Categories used in the

Table 1. Length-weight relationship of zooplankton  
collected in Stonehouse Pond, New Hampshire.



---

Genus	Length-weight Relationship
<u>Daphnia</u> spp.	$y = 0.02794x - 0.01365$
<u>Holopedium</u> sp.	$y = 0.00686x + 0.01206$
<u>Diaptomus</u> spp.	$y = 0.01629x + 0.00061$
<u>Cyclops</u> sp.	$y = 0.01610x - 0.00080$

---

where:  $y$  = dry weight in ug

$x$  = length in mm

analyses were algae, bacteria and detritus. Fragile algae such as flagellates eaten by zooplankton may not be recognized in the gut and therefore may have been counted as algae, detritus or not at all.

#### Lake Parameters

Carbon dioxide, dissolved  $O_2$ , temperature, pH, dissolved solids and light transmittance were measured with instrumentation and standard analytical procedures (American Public Health Association, 1971).

#### Phytoplankton Analysis

Phytoplankton samples were collected from incurrent pump water and preserved in Lugol solution. One ml aliquots were removed, allowed to settle for 24 hours, and species counted with the inverted microscope according to Lund, Kipling and Le Cren (1961).

#### Phosphorus Model

The data used to construct the phosphorus model presented in a later section was compiled from field collections and from the literature. Zooplankton phosphorus concentrations were calculated using value given for Daphnia ( $18 \mu\text{g P mg}^{-1}$ ), (Peters et al., 1973) and Calanus ( $6.6 \mu\text{g P mg}^{-1}$ ), (Marshall and Orr, 1955). The Calanus value was used for calanoid copepods in Stonehouse Pond. Since no values were found for rotifers the phosphorus value ( $10 \mu\text{g P mg}^{-1}$ ) was assumed between that of Daphnia and Calanus.

The rate used in the model for XP released by seston is approximately 0.01 times that calculated for  $\text{PO}_4$  (Lean, 1973b). The grazing rate ( $6.95 \text{ ml mg}^{-1} \text{ hr}^{-1}$ ) was calculated from data reported by Haney (1970).

Day-based calculations of Daphnia grazing may underestimate actual rates by a factor of 4 times. (Haney and Hall, 1974).

The general model used in this study was originally presented by Lean (1973b). I have divided his seston compartment into two separate compartments (seston and zooplankton) to facilitate the use of phosphorus excretion data for the zooplankton fraction.

## III. METHODS AND MATERIALS

## Phosphorus Characterization of Excretion Products

Zooplankton were collected in oblique tows from the hypolimnion to the surface with a plankton net (# 20 mesh). In the laboratory the animals were maintained for six to ten days at 15°C and fed algae previously labelled with  $^{32}\text{PO}_4$  (in 0.02 N HCl, New England Nuclear). Previous work by Johannes (1964a) and Peters (1972) indicated that the feeding period necessary for isotopic equilibrium of the animals with the food suspension was five to six days. Therefore, it was assumed that the experimental animals had reached equilibrium by six to ten days. The animals were then placed in a transfer chamber in which they could be moved through a series of five beakers without being lifted free from water. The chamber was constructed of an acrylic cylinder seven centimeters in diameter and closed at the base. Nitex netting (31  $\mu$ ) was inserted in the walls of the cylinder one cm from the closed end. This design offered a reservoir of approximately 22 ml when the chamber was lifted from the beakers. Zooplankton were first transferred to the first of three beakers which contained a dextran bead suspension (0.5 to 20  $\mu$  dia.) for the purging of the gut of the animals. The density of the bead suspension was maintained between 0.75 to 1.0 x 10<sup>5</sup> beads ml<sup>-1</sup> to ensure a maximum filtering rate and thus a maximum purging rate (Burns and Rigler, 1967). The zooplankton remained in the bead suspension for a

period of one hour after which they were washed free of beads and feces in the remaining containers and the excretion products collected for 30 minutes. The resulting solution was Millipore filtered ( $.45 \mu$ ) and samples removed for ultraviolet spectroscopy, gel filtration and seston incorporation studies.

#### Gel Filtration

Sephadex gel (G-25) was used in all filtration studies. The gel can be used for separating substances according to their molecular weight. The molecules of a substance penetrate the gel particles to a varying extent depending upon their size and shape. Those molecules above the exclusion limit of the specific gel cannot penetrate the particles and are eluted at the void volume of the column used. Molecules are therefore eluted from the gel in order of their decreasing molecular weight. The gel was used in this study to characterize the molecular weight of the zooplankton phosphorus excretion products.

A 20 ml sample of the filtrate was placed on a chromatography column (2.5 x 30 cm) packed with Sephadex gel, and 40 to 50 fractions eluted with 0.3% NaCl and 0.5%  $\text{NaN}_3$  (Lean, 1973a). The flow rate of the eluant was maintained at 1.0 ml per minute and 5 ml fractions were collected. A one ml aliquot was removed from each fraction and placed in a vial with 10 ml of Aquasol and

counted by liquid scintillation. The activity was plotted versus volume eluted.

#### Seston Incorporation of Excretion Products

A method for describing the exponential rate of disappearance of a substance from a pool is presented by Riggs (1963). In this study this method was used to characterize the uptake of zooplankton phosphorus excretions by natural seston.

Thirty to 40 ml of filtrate were added to 100 ml of lake water and thoroughly mixed. Two ml samples were removed at varying time intervals. In one experiment, for example, samples were taken at 0.4, 0.9, 1.4, 1.8, 2.3, 5.1, and 9.3 minutes. The samples were filtered with 45  $\mu$  Millipore filters and one ml subsamples placed in vials with Aquasol and counted by liquid scintillation. The rate of uptake of the phosphorus released products by natural seston was calculated according to Zilversmit, Entenman, and Fishler (1943). In a parallel experiment  $^{32}\text{P}\text{O}_4$  was added to lake water and the uptake rate calculated. A comparison of the rates was made.

#### Ultraviolet Spectroscopy

Nucleic acids contain one phosphorus atom per nitrogenous base and are potential excretion products, therefore, ultraviolet spectroscopy was used in this characterization study as described by Beaven, Holiday and Johnson (1955).

A ten to twenty ml sample of the filtrate containing the excretion products was reduced to two ml by lyophilization and placed in a scanning spectrophotometer. The absorbance of the sample was traced through a range from 370 to 200  $\mu$ m. A control sample was treated similarly and the two absorbance curves compared. Unlyophilized samples of the excretion products were also scanned.

#### IV. RESULTS

##### Temporal and Spatial Phosphorus Excretion Study

##### Phosphorus Observations

Seasonal phosphorus excretion rates observed in the epilimnion and hypolimnion are illustrated in Figs. 5 and 6. December and January data are lacking because unsafe ice conditions on the lake made sampling impossible. Excretion rates for the 1.05 mm group are also not given since too few animals were collected in this group (generally 1-2 percent of the numbers in the 0.308 mm group) to permit accurate estimates of phosphorus changes during the incubation.

Similar patterns were evident in both lake strata with peak rates in the fall and spring and low rates during the winter period.

The maximum and minimum excretion rates recorded in the epilimnion and hypolimnion are given in Table 2.

The dimictic pattern of excretion rates indicated periods of high and low metabolic activity. In the surface stratum the highest rates for the larger size group (0.308 mm) occurred on August 28, 1972 and May 17, 1973 while those of the smaller (< 0.308) were recorded on October 23, 1972 and June 20, 1973. The excretion patterns in the hypolimnion were not so clearly defined although there was a lag between the size groups similar to that in the epilimnion. During the cold months a drop in rates in all groups indicated



Fig. 5. Phosphorus excretion rates of zooplankton in the > 0.308 (-----) and < 0.308 mm (-.-.-.-.-) size groups collected in the epilimnion of Stonehouse Pond, New Hampshire from August 7, 1972 to July 18, 1973.

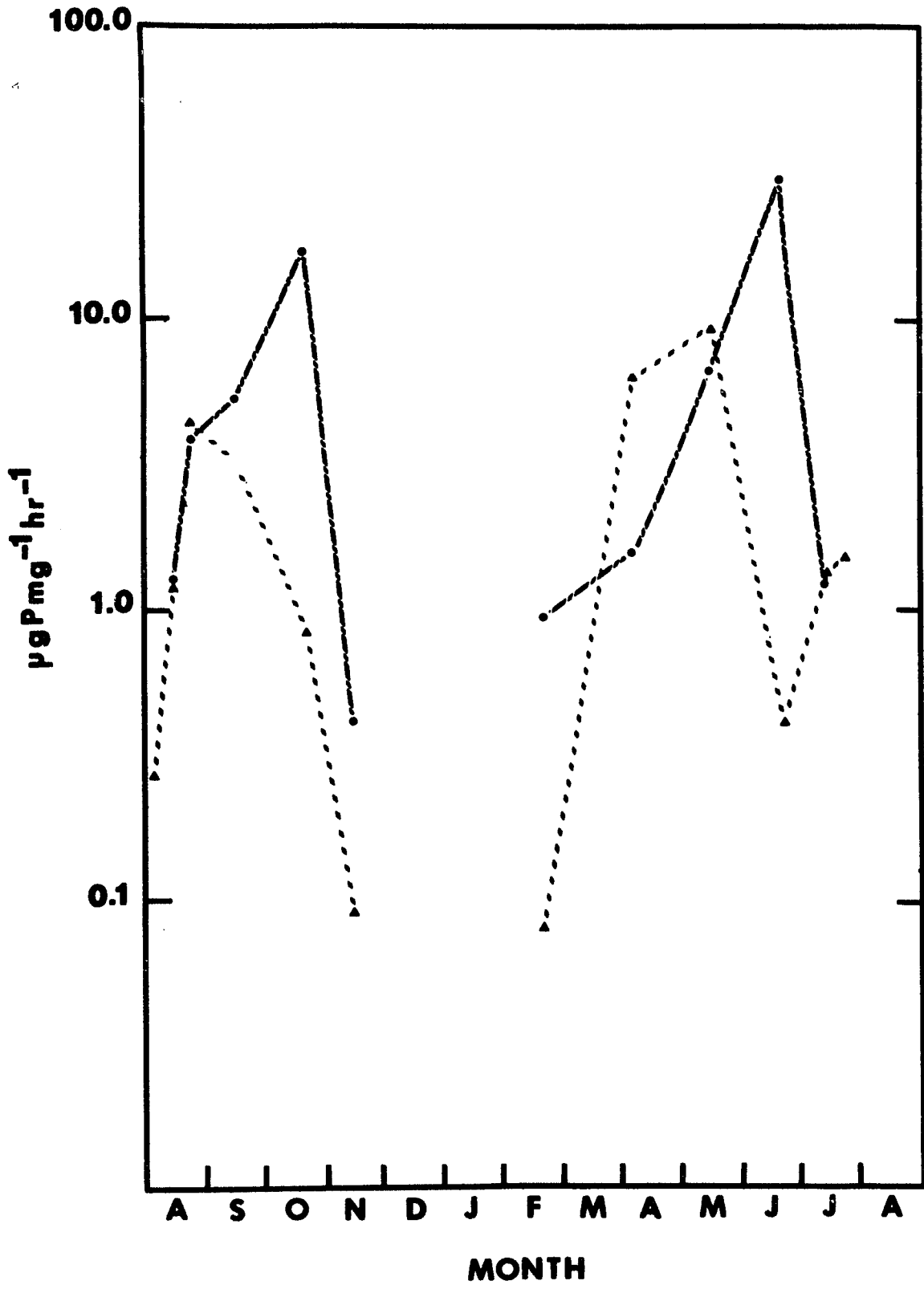

Fig. 6. Phosphorus excretion rates of zooplankton in the  
> 0.308 (-----) and < 0.309 mm (-.-.-.-) size  
groups collected in the hypolimnion of Stonehouse  
Pond, New Hampshire from August 7, 1972 to  
July 18, 1973.

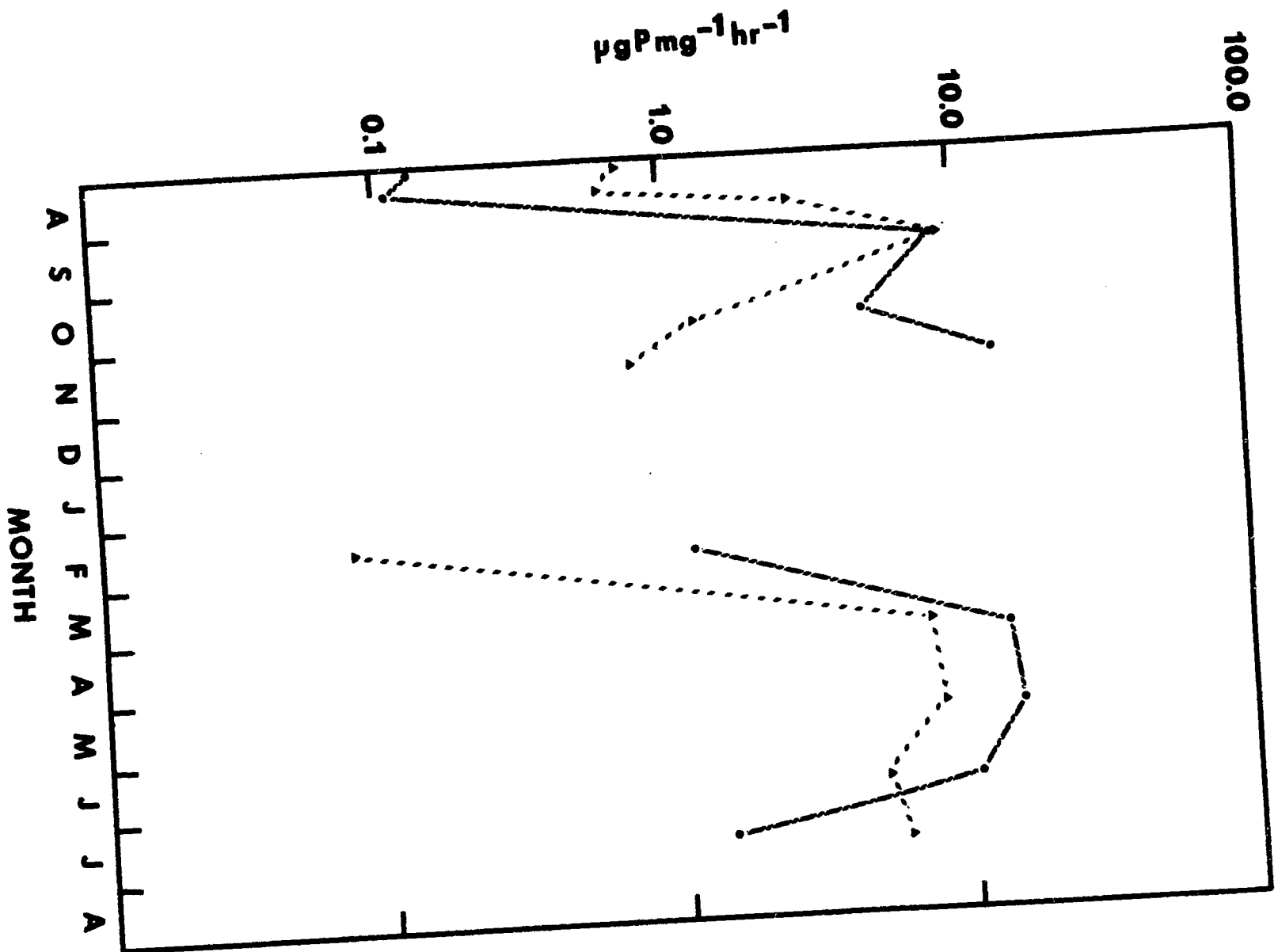

Table 2. Maximum and minimum rates of zooplankton phosphorus excretion in the epilimnion and hypolimnion for 0.308 and < 0.308 mm size groups.

Size Group	Epilimnion			Hypolimnion		
	Min.	Max.	Range	Min.	Max.	Range
> . 308 mm	0.080	9.245	9.246	0.080	25.376	25.296
< . 308 mm	0.432	28.560	28.128	0.114	15.407	15.293

a drop in metabolic activity probably due to low water temperatures and decreased food supplies. The mean annual excretion rates for the surface water 0.308 and < 0.308 mm groups were 2.435 and 5.533  $\mu\text{g P mg}^{-1} \text{ hr}^{-1}$  respectively. These compare with 5.336 and 7.089  $\mu\text{g P mg}^{-1} \text{ hr}^{-1}$  for the hypolimnion. These data are slightly higher than previously reported by other investigators.

Soluble reactive phosphorus in lake water also followed a dimictic pattern (Fig. 7) and in the epilimnion was highly correlated ( $r = .01$ ) with the combined excretion rates of the 0.308 and < 0.308 mm groups. The significance of this correlation is discussed in a later section.

#### Water Chemistry

Chemical and physical measurements were made at the depth of each pump and may not represent the entire stratum. Temperatures in the epilimnion (3.0 to 24.0°C) varied considerably more than in the hypolimnion (4.0 to 9.0°C). Although the dissolved oxygen never fell below 4.4  $\text{mg l}^{-1}$  at either pump depth, profiles during the summer indicated an oxygen depletion below 12 m. Carbon dioxide was almost constant in the epilimnion and ranged between 5.1 and 2.0  $\text{mg l}^{-1}$ . The  $\text{CO}_2$  content of hypolimnetic water was much more variable and in late August the concentration rose from 11.2 to 14.7  $\text{mg l}^{-1}$  in September. During the same period pH was between 5.4 to 6.0 in both strata. The hypolimnetic pump was located around the 1 percent light level except

Fig. 7. Soluble reactive phosphorus levels in the epilimnion and hypolimnion of Stonehouse Pond, New Hampshire from August 7, 1972 to July 18, 1973. Epilimnion (- - - -), Hypolimnion (————).



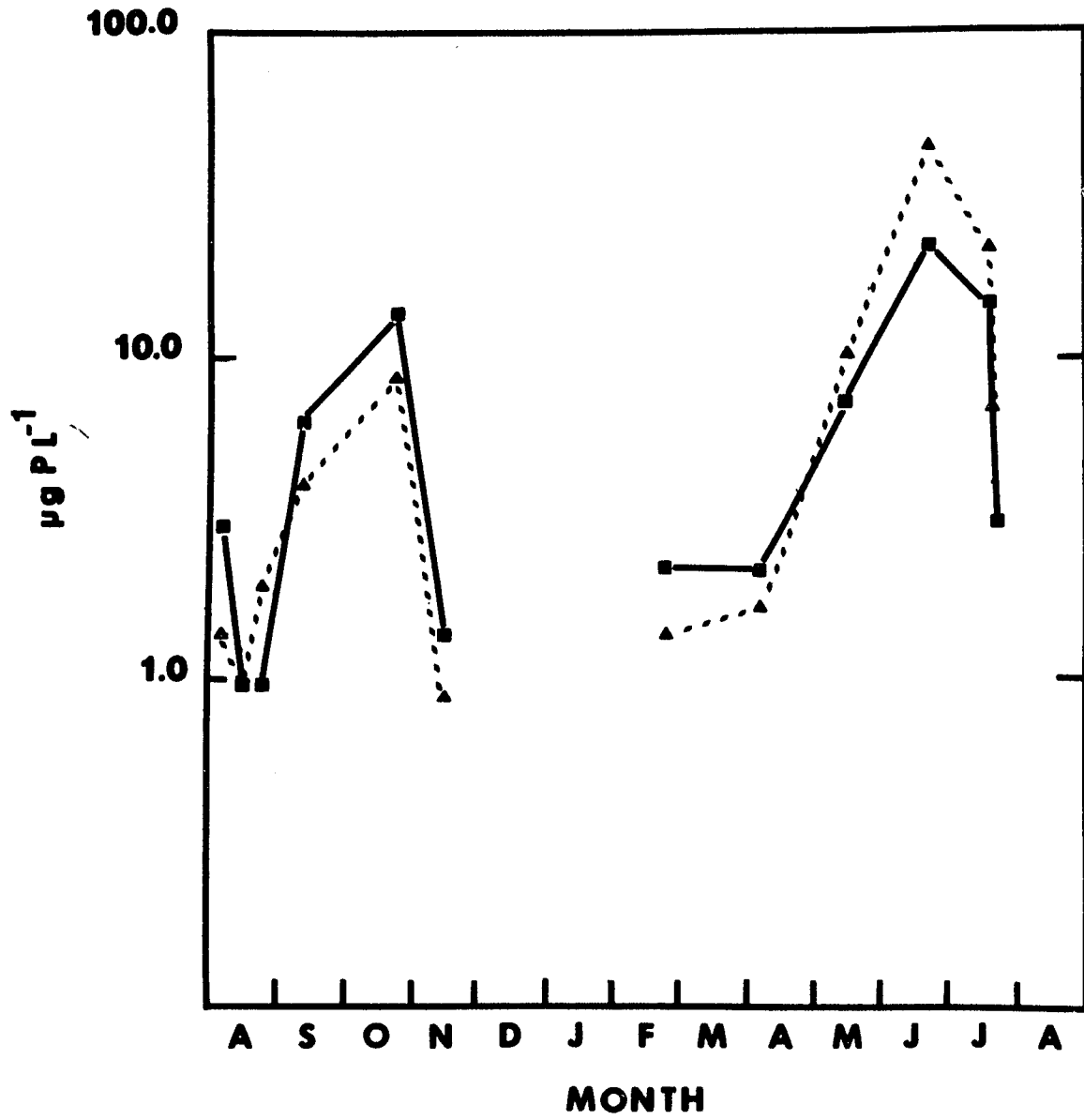

during periods of ice cover when it was located below this level. The dissolved solids remained within 30 to 70  $\mu\text{mho}$ , a range normal for soft water lakes in New Hampshire.

### Zooplankton

Five orders and 15 genera of limnetic zooplankton were represented in experimental collections (Table 3). Daphnia, Diaptomus and Cyclops were the most abundant genera in the 0.308 mm group throughout the year except during short periods when Holopedium were abundant. Stonehouse Pond is a Cladocera-dominated system since Daphnia and Holopedium were numerically dominant over the period of the study. The zooplankton in the < 0.308 mm samples was almost exclusively made up of rotifers dominated by the genus Polyarthra.

Seasonal variation in abundance and percent composition of Daphnia, Diaptomus was dimictic and for Cyclops amictic. Percent composition of the three genera is illustrated in Fig. 8. During the months of April and May the percent composition of zooplankton changed, Cyclops increased numerically while Diaptomus and Daphnia decreased in abundance. As shown below, this change in percent composition may have an effect on community phosphorus excretion during the same period. From August 16, 1972 to February 22, 1973, Daphnia and Diaptomus comprised the bulk of the zooplankton population in both strata. Daphnia were dominant numerically on all sampling dates except November 17, 1972, on this date

Table 3. Species of zooplankton collected in Stonehouse Pond, New Hampshire from August 16, 1972 to July 19, 1973.

## Cladocera

Daphnia catawba

Daphnia pulex

Daphnia ambigua

Diaphanasoma sp.

Holopedium gibberum

Bosmina sp.

Polyphemus pediculus

## Calanoida

Diaptomus pygmaeus

Diaptomus spatulocrenatus

Cyclops scutifer

Tropocyclops prasinus

## Ploima

Keratella quadrata

Keratella cochlearis

Kellicottia longispina

Conchilus unicornis

Asplanchna periodonta

Polyarthra vulgaris

Trichocerca sp.

## Flosculariaceae

Filina sp.

Fig. 8. Percent composition of Daphnia, Diaptomus, and Cyclops in the epilimnion and hypolimnion of Stonehouse Pond, New Hampshire from August 16, 1972 to July 18, 1973. The left half of each column indicates epilimnion composition, right half hypolimnion.

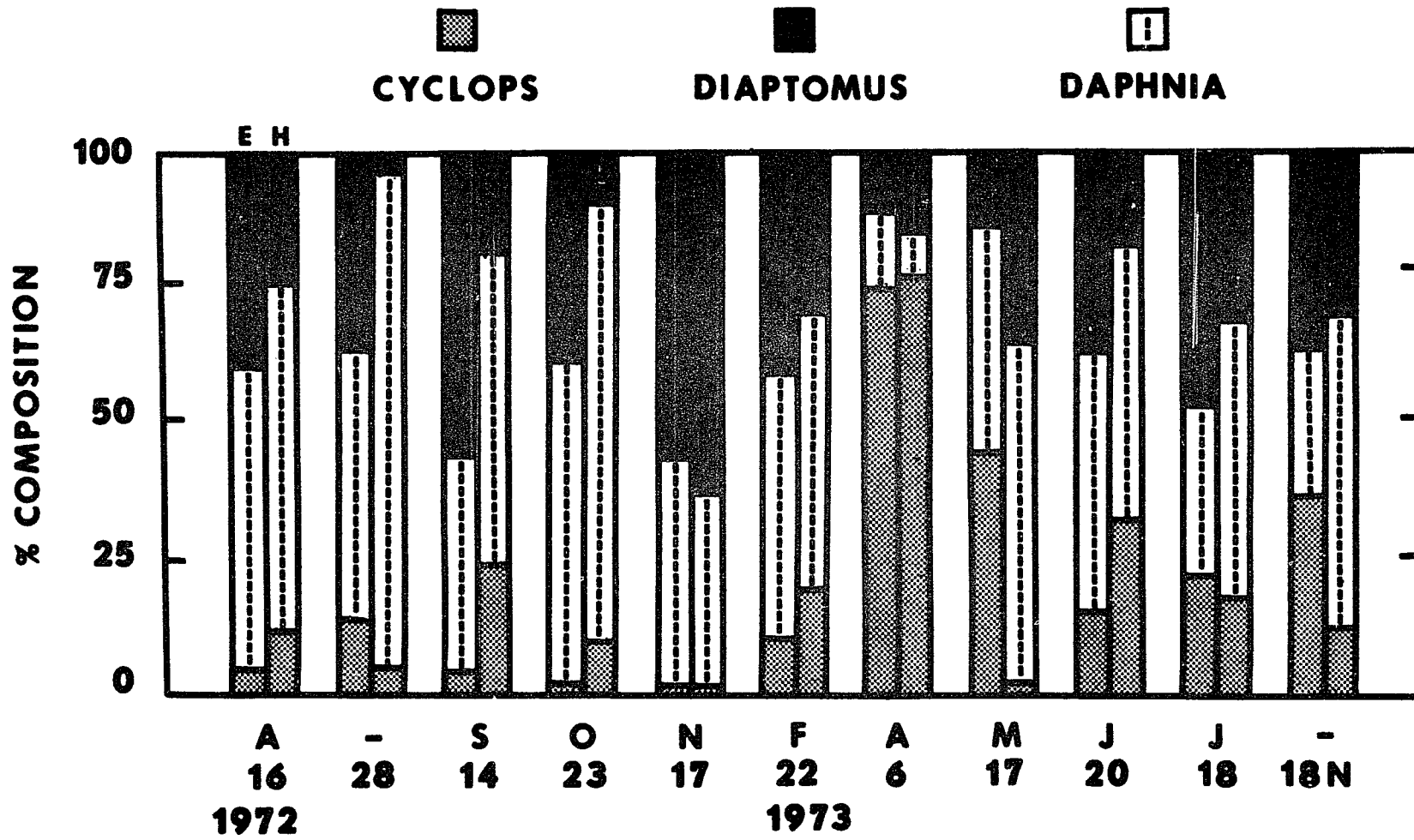

Diaptomus was the most abundant zooplankter. Daphnia composed 93.9 percent of the zooplankton in the hypolimnion (September 23, 1973). Diaptomus reached 63.8 percent on November 17 in the hypolimnion and was the most abundant animal in both the epilimnion and hypolimnion on this date. Between April 6 and May 17, 1973, Cyclops formed 96.4 percent of the number of animals collected in either lake stratum.

#### Phytoplankton

Table 4 indicates phytoplankton species collected from August 16, 1972 to July 9, 1973. The dominant genus in both strata during all seasons except winter was a cyanophyte, Merismopedia. During the winter months several genera were equal in abundance. At times Merismopedia accounted for as much as 90 percent of the number of cells collected. Fig. 9 illustrates the temporal variation in total phytoplankton abundance in the epilimnion and hypolimnion.

#### Phosphorus Model

Kinetic analysis of phosphorus in the compartmental model indicates that during the spring of 1973 the amount of phosphorus excreted by zooplankton was not sufficient to meet that utilized by the seston in Stonehouse Pond.

Table 4. Phytoplankton genera collected in the epilimnion and hypolimnion of Stonehouse Pond, New Hampshire from August 16, 1972 to July 19, 1973.



EpilimnionChlorophyta

\*Chlorella  
 \*Mougeotia  
Oöcystis  
Chlamydomonas  
Scenedesmus  
Schroedesia  
Eudorina  
 \*Xanthidium  
Sphaerocystis

Chrysophyta

Mallomonas  
Dinobryon  
Ophiocytium  
Asterionella  
Elakatothrix  
 \*Melosira  
 \*Navicula  
 \*Achnanthes

Pyrrophyta

\*Glenodinium  
 \*Peridinium

Cyanophyta

Merismopedia  
 \*Chroococcus  
Aphanocapsa  
Spirulina  
Anabaena

Euglenophyta

Trachelomonas

Misc.

Cryptomonas

Unidentified coccoids, dinoflagellates and flagellates were found in both strata.

\*Those genera found exclusively in this strata.

HypolimnionChlorophyta

Oöcystis  
 \*Ankistrodesmus  
 \*Dictyosphaerium  
Schroedesia  
Chlamydomonas  
 \*Lagerheimia  
Sphaerocystis

Chrysophyta

Mallomonas  
Asterionella  
Elakatothrix  
Ophiocytium  
 \*Frustulia

Cyanophyta

Merismopedia  
Aphanocapsa

Misc.

Cryptomonas  
 \*Rhodomonas

Fig. 9. Seasonal pattern of phytoplankton numbers in the epilimnion (-----) and hypolimnion (-.-.-.-.-) of Stonehouse Pond, New Hampshire from August 16, 1972 to July 18, 1973.

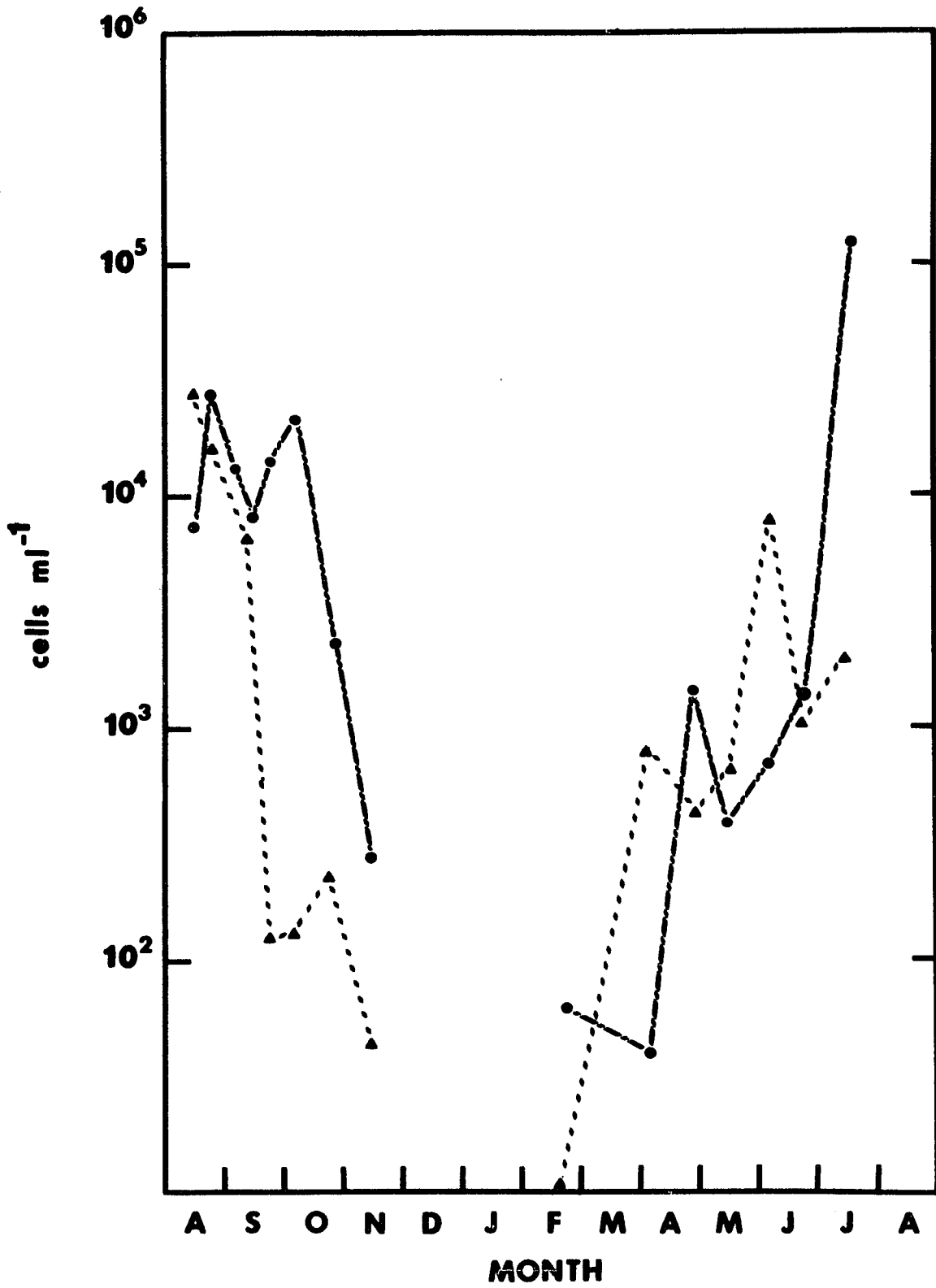

#### IV. RESULTS

##### Phosphorus Characterization of Excretion Products

###### Zooplankton Species Analysis

Zooplankton were identified after each experiment and the following species were found in all experimental collections: Diaptomus pygmaeus, D. spatulocrenatus, Daphnia pulex, D. catawba, Holopedium gibberium, Bosmina sp., Diaphasoma sp., Cyclops scutifer, Keratella cochlearis, and Kellicottia longispina. Although some differences in percent composition were observed between collections, these were small and not considered important.

###### Seston Incorporation

A comparison of the incorporation rates of  $^{32}\text{P}$ -labelled zooplankton excretions and  $^{32}\text{P-PO}_4$  by natural seston indicates that they behave similarly (Fig. 10). Although the initial rate of  $^{32}\text{P-PO}_4$  loss from the lake water was slightly higher, subsequent uptake rates of the two labelled products were not different (Table 5).

###### Gel Filtration

The bulk of soluble excretion products eluted from the columns was located in the same position as that of  $^{32}\text{P-PO}_4$  (Fig. 11). This suggests that the soluble phosphorus excretion product of the experimental zooplankton was the same molecular weight as orthophosphate. During several experiments a small peak was also located between the orthophosphate position and the void volume.

Fig. 10. Uptake curve of  $^{32}\text{P}$ -labelled zooplankton excretion (A) and  $^{32}\text{P-PO}_4$  (B) by natural seston on July 3, 1974. (curves fitted by eye).

LOG PERCENT  $^{32}\text{P}$  IN THE FILTRATE

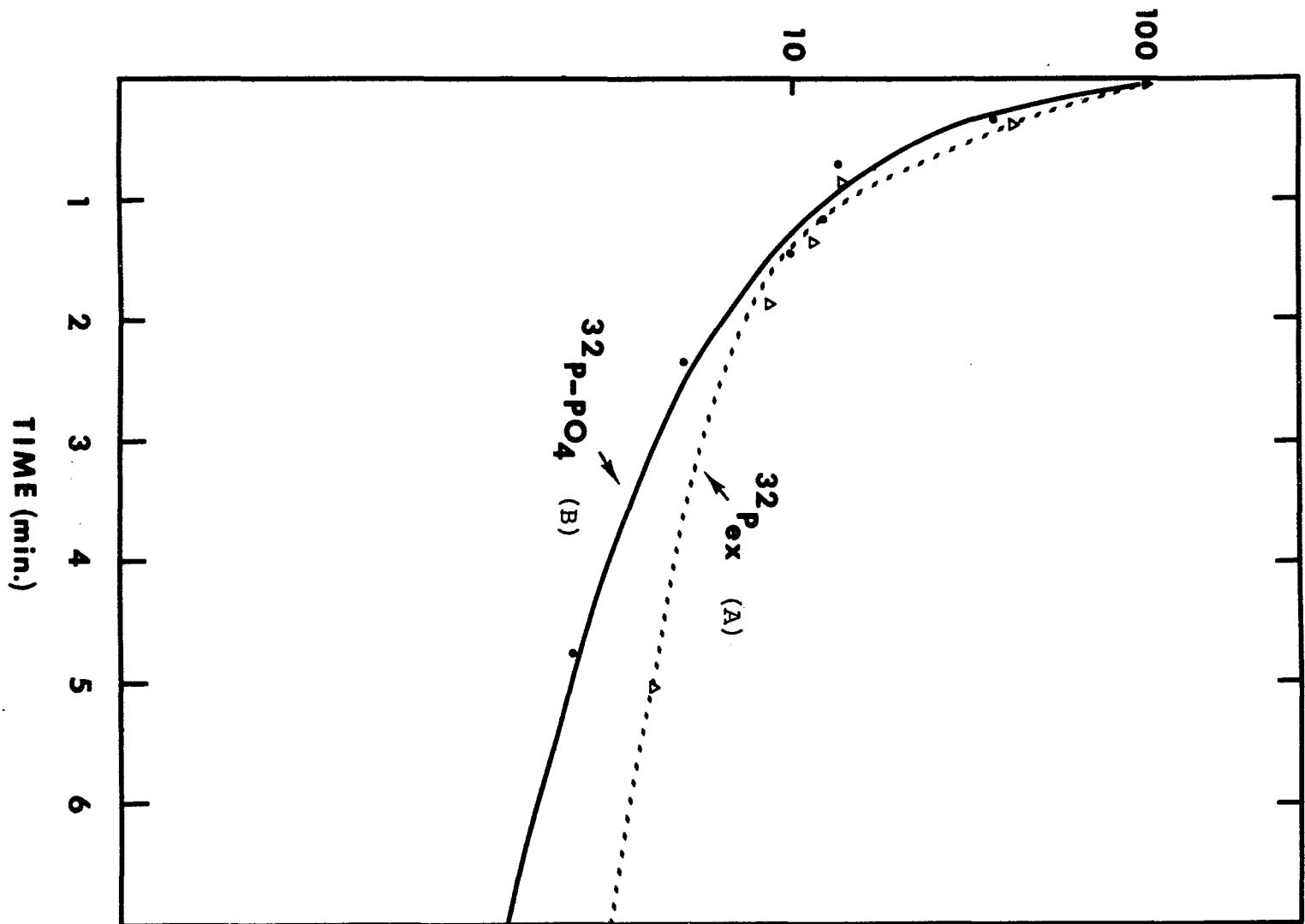

Table 5. Turnover time of  $^{32}\text{P-PO}_4$  and  $^{32}\text{P}$ -labelled zooplankton excretions by natural seston, spring 1974. Time expressed in minutes.

---

Date	$^{32}\text{P-PO}_4$	$^{32}\text{Phosphorus}$ Excretion
March 7, 1974	2.174	2.084
June 21, 1974	1.935	1.835
July 10, 1974	1.848	2.016

---



Fig. 11. Sephadex gel filtration curve of  $^{32}\text{P-PO}_4$  and  $^{32}\text{P}$ -labelled zooplankton excretion.

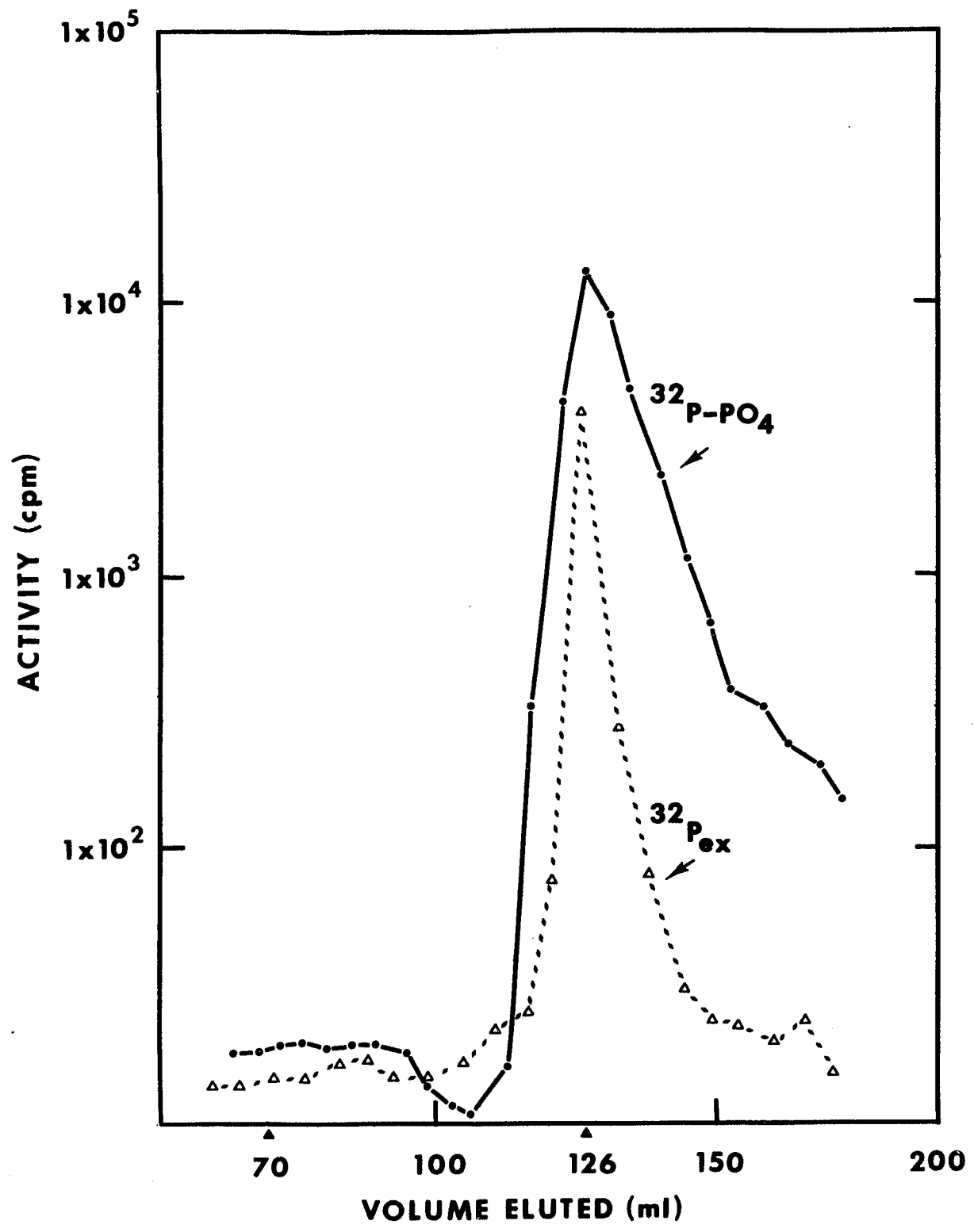

This compound was not found in all experiments when the released products were used and never when the  $^{32}\text{P-PO}_4$  was used. The higher molecular weight unknown never exceeded 15 percent of that found at the orthophosphate position. The peak may be a small amount of organic phosphorus released with the orthophosphate.

#### Ultraviolet Spectroscopy

No detectable amounts of nucleic acids, purines, pyrimidines or nucleotides were found using the excretion products of the zooplankton collected during the spring of 1974 in Stonehouse Pond even after 10 x concentration by lyophilization.

## V. DISCUSSION

### Studies on Temporal and Spatial Phosphorus Excretion

An inverse relationship between excretion rates and body size has been attributed to higher metabolic rates of the smaller organisms (Johannes, 1964b). By specifically separating various size groups of zooplankton from the epilimnion and hypolimnion I have been able to further verify this relationship. In the epilimnion the rate of excretion by the 0.308 mm group exceeded that of the < 0.308 mm only two times in 11 sampling trips. The average rate in the smaller size groups was two times that of the larger. Data gathered from organisms collected in the hypolimnion was not so clearly defined although the same relationship existed. The average difference was slightly more than 1.3 times for the smaller group and 5 of 11 rate determinations for the 0.308 mm zooplankton were higher than those of the < 0.308.

Single and stepwise multiple correlations were run between physical, chemical and excretion data in an attempt to indicate factors which influence zooplankton excretions. A direct relationship was observed between phosphorus excretion, temperature and phytoplankton biomass on several dates. However, no significant correlations were found between annual physical and chemical parameters measured, phytoplankton biomass and phosphorus excretion. The correlation between SRP in Stonehouse Pond water and phos-

phorus excretion in the epilimnion ( $r = .01$ ) is interesting to note. If the zooplankton excretion was responsible for the rise in lake phosphorus the rate of excretion would have had to exceed phosphorus utilization by lake seston. Sufficient data are not available to speculate for the entire year, but in the period between February 22, 1973 and July 18, 1973 zooplankton excretions do not seem to be sufficient to cause the observed increase in SRP.

#### Zooplankton Feeding

Selectivity in the size of food items of zooplankton has been shown by Burns (1968), however, availability of each food item affects the relative proportion of algae, bacteria and trypton selected (Gliwicz, 1968). Thus, what effect might a change in the composition of food ingested by zooplankton have on their phosphorus excretion? During April and May a high excretion rate was observed even though low numbers of phytoplankton were found. Large amounts of allocthonous material were washed into the lake following unusually high rainfall during these same months. Recognizable gut contents of Daphnia and Diaptomus collected consisted of approximately 70 percent, by volume, bacteria and detritus. Throughout the remainder of the year these same food items accounted for approximately 15 percent. These data suggest that the primary food and ultimately the source of phosphorus for zooplankton was bacteria and detritus. Either higher

assimilation efficiency or greater phosphorus content of bacteria and detritus would result in higher rates of excretion as observed when they were used almost exclusively as a food source. According to Fedorovo and Sorokin (1967), Daphnia and Simocephalus assimilate bacteria better than algae. In addition, Daphnia are also able to assimilate detritus more efficiently than algae (Saunders, 1969). These data suggest that the assimilation efficiency of the food consumed by zooplankton is an important consideration in excretion studies.

Although Merismopedia was dominant in most phytoplankton collections, it was not found in any gut analyses. D. Schindler (1968), J. Schindler (1971) and Arnold (1971) in their experiments with zooplankton nutrition indicate that the Cyanophyta nutritionally are a poor food for zooplankton. Arnold fed Merismopedia to zooplankton and showed that animals fed exclusively on this alga had no natural increase in numbers at any test concentration. He observed also low survivorship of animals and indicated a possible toxic effect may have been influencing his results.

Merismopedia tended to clump in Stonehouse Pond and aggregates  $> 40 \mu$  in diameter were common. According to Burns (1966) and Gliwicz (1968) smaller size particles are selected for by zooplankton. Most gut analyses of the animals examined contained material  $< 5 \mu$  in diameter. This would suggest that zooplankton select against this genus in

the lake.

### Zooplankton Species Composition

Barlow and Bishop (1965) considered community species composition in Cayuga Lake, New York and how it affected the rate and quantity of phosphorus excretion by those animals collected in the hypolimnion. They found that cladocerans dominated in the epilimnion while copepods were more abundant in the hypolimnion. On this basis they inferred that this may account for the larger amount of phosphorus released in the epilimnion. Figure 8 shows the relative abundance of the three dominant genera of zooplankton in the epilimnion and hypolimnion of Stonehouse Pond. The distribution of zooplankton groups is not limited by the stratification of the lake and generally as many Cladocera were found in the hypolimnion as were found in the epilimnion. For this reason differential excretion because of spatial distribution of zooplankton groups was not observed. During April and May, 1973 the Cyclops were more abundant than Daphnia and Diaptomus. A significant amount of data has been collected on the phosphorus excretion of Daphnia and some preliminary in situ studies with Diaptomus but little if any work has been reported on the phosphorus excretion of a predator species. In preliminary work (LeRow, personal communication) indicates predators excrete phosphorus at a higher rate than herbivores because

Fig. 12. The compartmental model of the biological  
phosphorus cycle.

XP = labile phosphorus (intermediate molecular  
weight)

ZP = zooplankton

S = seston

Se + Se' = algal secretion

UP = seston phosphorus uptake

Gr = zooplankton grazing

Ex = zooplankton excretion

Co = condensation



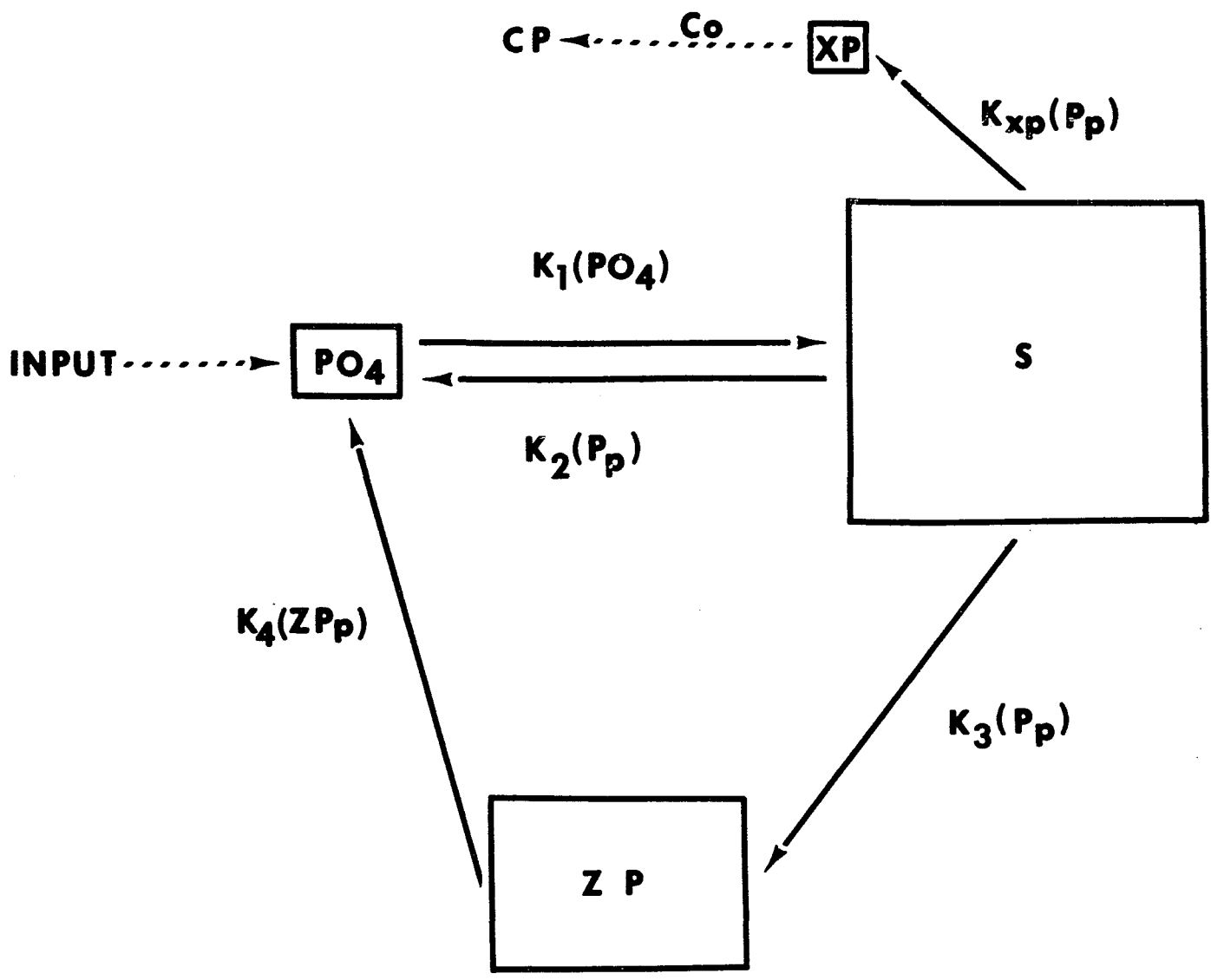

of their higher assimilation efficiencies. Since this data is not yet available, this raises the question as to the effect of a large influx of animals from this trophic level on the phosphorus cycle.

#### Phosphorus Model

Any consideration of the role of zooplankton in the phosphorus cycle and the contribution of their excretion products relative to phytoplankton requirements must include a sufficient number of the biological compartments involved in the transfer of phosphorus within the system. The C:P ratio of algal utilization and phosphorus excretion products of zooplankton are insufficient to understand the role of these products in primary production. Lean (1973a) emphasized the importance of the rate of movement of phosphorus between two main compartments,  $PO_4$  and seston, and also described a route which involves labile and colloidal fractions. The extremely rapid uptake of the phosphate by seston was considered also by Peters (1972), Peters *et al.*, (1973), and Lean (1972). The model of phosphorus cycle in the epilimnion presented in Fig. 12 includes the following measured parameters: zooplankton phosphorus excretion, uptake and secretion rates of phosphorus by natural seston, SRP in lake water, and zooplankton and particulate phosphorus. Table 6 is a list of mass equations which illustrate the various components used to describe the movement of phosphorus between the compartments in the epilimnion. If equilibria were to exist

Table 6. Mass balance equations indicating the movement of phosphorus in lake water.

---

Net Phosphorus Uptake	$\frac{dPO_4}{dt} = -K_1(PO_4) + K_2(P_p) + K_4(ZP_p)$
--------------------------	--

---

Net Phosphorus Loss	$\frac{dZP_p}{dt} = -K_4(ZP_p) + K_3(P_p)$
------------------------	--

---

Net Seston Loss	$\frac{dS_p}{dt} = -K_3(P_p) - K_2(P_p) - K_{xp}(P_p) + K_1(PO_4)$
-----------------	--

---

where:  $PO_4$  = phosphate level in lake water

$P_p$  = particulate phosphorus

$ZP_p$  = zooplankton phosphorus

$S_p$  = seston phosphorus

$K_1$  = turnover rate

$K_2$  = secretion rate

$K_3$  = zooplankton grazing rate

$K_4$  = phosphorus excretion rates

$K_{xp}$  = .01 x secretion rate

between any two or more compartments no net change in phosphorus would take place between the compartments. Since this condition is never found in biological systems (Morowitz, 1968), it was not surprising to find both positive and negative equation results, Table 6.

The sign convention used in the model relies on the neutral condition of steady state where there is no net movement between compartments. A negative value in a compartment indicates that more phosphorus is leaving that compartment than can be accounted for from the input sources in the model. The transfer between compartments is always positive. An assumption which the author recognizes to be somewhat questionable is that the only sources of phosphorus in this system are accounted for by the compartments. This assumption serves the requirements of this model and will be discussed later.

From February 22 to June 20, 1973 there was a steady increase in the zooplankton excretion rate, phytoplankton biomass and SRP in the epilimnion. Between May 17 and June 20, 1973 there also was a bloom of Merismopedia (indicated by June 20 phytoplankton data (Fig. 9)). This suggests that phosphorus was available for rapid algal reproduction during this period and raises the question whether zooplankton excretion could account for this available phosphorus.

In constructing a model for this period of the year four dates were considered, February 22, April 6, May 17 and June 20.

On the dates indicated above the net phosphorus content of the seston compartment was always negative (-88.4358 to -0.1076) (Table 7). These negative numbers indicate that the amount of phosphorus moving into this compartment was never sufficient to offset that lost to zooplankton grazing and secretion. This may also indicate a phosphorus limiting condition. Less than half of the net  $PO_4$  compartment data is positive (+ = zooplankton phosphorus excretion sufficient to offset that lost to seston), and at no time was the  $PO_4$  concentration large enough to meet seston requirements. Grazing rates of zooplankton on seston, which includes algae, bacteria and trypton, were always sufficient to meet the phosphorus requirements of the zooplankton. It follows that if the  $PO_4$  concentrate was not sufficient to meet seston requirments at any time it could not account for the increase in SRP in the lake water during this period. This would indicate that another phosphorus source or sources is available for lake seston. The existance of another source of phosphorus other than zooplankton excretion does not alter the fact that excretion rates were not sufficient to meet seston phosphorus requirements during this period. Rates of phosphorus movement between compartments for February 22, April 6, May 17 and June 20 are given in Table 8.

The calculations and conditions for this model may be unique for the spring of 1973 in Stonehouse Pond. The model presented here covers a short period and therefore

Table 7. Net phosphorus content of  $PO_4$ , zooplankton and seston compartment in Stonehouse Pond on February 22, April 6, May 17, and June 20, 1973.

	February 22	April 6	May 17	June 20
$\frac{dPO_4}{dt}$	-0.0252	+0.3969	-0.1265	-3.1466
$\frac{dZP_p}{dt}$	+2.8857	+88.9599	+0.2331	-8.8758
$\frac{dS_p}{dt}$	-2.844	-88.4358	-0.1076	-5.6946

where:  $PO_4$  = SRP in lake water

t = time

$ZP_p$  = zooplankton phosphorus

$S_p$  = seston phosphorus (PP)

+ = increase in net phosphorus content

- = decrease in net phosphorus content



Table 8. Rates of phosphorus movement between compartments of model for Feb. 22, April 6, May 17, and June 17, 1973.

Date	$K_1(\text{PO}_4)$ $\mu\text{g P hr}^{-1}$	$K_2(\text{P}_p)$ $\mu\text{g P hr}^{-1}$	$K_3(\text{P}_p)$ $\mu\text{g P mg}^{-1} \text{hr}^{-1}$	$K_4(2\text{P}_p)$ $\mu\text{g P mg}^{-1} \text{hr}^{-1}$
Feb. 22, 1973	0.0370	0.0110	2.8917	0.0006
April 6, 1973	0.0640	0.4608	88.960	0.0001
May 17, 1973	0.1438	0.0002	0.2502	0.0172
June 17, 1973	3.1820	0.0512	88.960	0.0203

cannot account for other periods of the year when some of the important variables such as turnover rates and seston phosphorus requirements may vary.

The model has additional limitations since only day-time data was used, and phosphorus input sources such as sediment-water exchange and precipitation were not included.

## V. DISCUSSION

## Phosphorus Characterization of Excretion Products

Examination of zooplankton excretion products by gel filtration, seston incorporation and ultraviolet spectroscopy suggests that the phosphorus component is almost entirely orthophosphate. These results are consistent with those found by Peters and Lean (1973) and suggest that the zooplankton phosphorus excretions function similarly to orthophosphate in the phosphorus cycle of a lake. The difference in the uptake of the phosphorus excretion products and orthophosphate may be due to the presence of a small amount of soluble organic phosphorus. Dissolved organic phosphorus is biologically unavailable to algae except those which show an ability to utilize specific phosphatases (Lean, 1973a). This unavailable fraction would decrease the apparent rate of utilization and raise the asymptote level. The absence of any nucleic acids in the excretions is also evidence that there was no breakdown of organic material from dead animals occasionally found after some experiments.

The role of the excretion products depends upon the ability of the seston components to utilize them as a source of phosphorus. Algae and bacteria are two components which compete for phosphorus during growth. Algal cells are capable of using some organic phosphorus through enzyme activity (Lin, 1971), however, the main needs of algae and bacteria are satisfied by orthophosphate. In some labora-

tory studies the bacteria Pseudomonas sp. successfully competed with Scenedesmus to an extent that it interfered with the growth of the algae (Rhee, 1971). Excretions of a natural population of zooplankton in this study are rapidly removed by components of the seston. Therefore, such excretion products may act as a phosphorus supplement for this suspended material.

During periods of low lake phosphorus, zooplankton excretions may constitute a significant source of phosphorus for algal and bacterial growth. Excretion rates of zooplankton in excess of  $15 \mu\text{g P mg}^{-1} \text{ hr}^{-1}$  were observed in Stonehouse Pond in the fall and late spring and these rates were not sufficient to satisfy the phosphorus utilization by the lake seston. The phosphorus requirements of the various species of algae are low, and some diatoms like Asterionella formosa need only  $1.0 \mu\text{g P l}^{-1}$  to produce populations as great as  $16 \times 10^6 \text{ cells ml}^{-1}$ . This diatom is only limited in its ability to reproduce at a phosphorus level of  $0.06 \mu\text{g P l}^{-1}$  (Mackereth, 1953). Apparently, the phosphorus need of several phytoplankton species could be satisfied by  $15 \mu\text{g P mg}^{-1} \text{ hr}^{-1}$ .

Some species of Volvox, Pandorina and Spirogyra are able to concentrate low levels of phosphorus and gain a reproductive advantage over faster growing forms during periods when phosphorus might be limiting (Provasoli,

1969). Since growth is a function of cellular phosphorus (Rhee, 1973), zooplankton excretions may play an important role in the composition of algal populations. Although evidence suggests that the amount of excretion can not meet seston utilization, it may have a pronounced affect on the phosphorus and seston dynamics of a lake.

## LITERATURE CITED

- American Public Health Association.- 1971 - Standard methods for the examination of water and wastewater (13 ed.) American Public Health Association, New York. 874 p.
- Arnold, D.E.- 1971 - Ingestion, assimilation, survival and reproduction by Daphnia pulex fed seven species of blue-green algae. *Limnol. Oceanogr.* 16(6):906-920.
- Arthur, C.R. and Rigler, F.H.- 1967 - A possible source of error in the  $C^{14}$  method of measuring primary productivity. *Limnol. Oceanogr.* 12(1):121-124.
- Barlow, J.P. and Bishop, L.W.- 1965 - Phosphate regeneration by zooplankton in Cayuga Lake. *Limnol. Oceanogr.* 10 (suppl.):15-24.
- Beaven, G.H., Holiday, E.R. and Johnson, E.A.- 1955 - Optical properties of nucleic acids and their components. p. 493-553. In Chargoff and Davidson (ed.) *The nucleic acids*. Vol. I, 692 p.
- Burns, C.W.- 1966 - The feeding behavior of Daphnia under natural conditions. Ph.D. Thesis, University Toronto, Toronto, Ontario. 88 p.
- Burns, C.W.- 1968 - The relationship between body size of filter-feeding Cladocera and the maximum size of particles ingested. *Limnol. Oceanogr.* 13(4):675-678.
- Burns, C.W. and Rigler, F.H.- 1967 - Comparison of filtering rates of Daphnia rosea in lake water and in yeast

- suspension of yeast. *Limnol. Oceanogr.* 12(3):492-502.
- Butler, E.I., Corner, E.D.S. and Marshall, S.M. - 1969 - On the nutrition and phosphorus excretion of *Calanus* in the Clyde-Sea area. *Jour. Mar. Biol. Assoc. U.K.* 50: 525-560.
- Chamberlain, W.- 1968 - A preliminary investigation of the nature and importance of soluble organic phosphorus in the phosphorus cycle of lakes. Ph.D. Thesis, University Toronto, Toronto, Ontario. 165 p.
- Chamberlain, W. and Shapiro, J.- 1969 - On the biological significance of phosphate analysis; comparison of standard and new methods with bioassay. *Limnol. Oceanogr.* 14(6):921-927.
- Cooper, L.H.N.- 1935 - The rate of liberation of phosphate in sea water by the breakdown of plankton organisms. *J. Mar. Bio. Assoc.*, 20:197-200.
- Fedorov, V.K. and Sorokin, Y.I.- 1967 - Determination of assimilation of algae, yeast and bacteria by some representative Cladocera. *Acad. Sci. USSR.* 174(4): 969-970. (Translation by J.F. Haney).
- Ferrante, John.- The role of zooplankton in the intrabio-coenotic phosphorus cycle and factors affecting phosphorus excretion in a lake. In Press.
- Fitzgerald, G.P. and Nelson, T.C.- 1966 - Extractive and enzymatic analysis for limiting or surplus phosphorus in algae. *J. Phycol.* 2:32-37.



- Ganf, G.G., and Blazka, P.- 1974 - Oxygen uptake, ammonia and phosphate excretion by zooplankton of a shallow equatorial (Lake George, Uganda). *Limnol. Oceanogr.* 19(2):313-325.
- Gliwicz, Z.M.- 1968 - The share of algae, bacteria and trypton in the food of the pelagic zooplankton of lakes with various trophic characteristics. *Hydrobiology.* 18(3): 158-165.
- Haney, J.F.- 1970 - Seasonal and spatial changes in the grazing rate of limnetic zooplankton. Ph.D. Thesis, University of Toronto, Toronto, Ontario. 165 p.
- Haney, J.F. and Hall, J.D.- 1973 - Sugar-coated Daphnia: A preservation technique for Cladocera. *Limnol. Oceanogr.* 18(2):331-333.
- Haney, J.F. and Hall, J.D.- 1974 - Diel vertical migration and filter feeding activities of Daphnia. *Arch. f. Hydrobiol.* (in press).
- Hargave, B.T. and Geen, G.H.- 1968 - Phosphorus excretion by zooplankton. *Limnol. Oceanogr.* 13(2):332-342.
- Johannes, R.E.- 1964a - Uptake and release of dissolved organic phosphorus by representatives of a coastal marine ecosystem. *Limnol. Oceanogr.* 9(2):224-234.
- Johannes, R.E. - 1964b - Phosphorus excretion and body size in marine animals: microzooplankton nutrient regeneration. *Science.* 146:923-924.
- Kuhl, A.- 1962 - Inorganic phosphorus uptake and metabolism. 718 p. In Lewin (ed.) *Environmental Phosphorus Handbook* John Wiley & Sons, N.Y.

- Lean, D.R.S.-1973a- Phosphorus compartments in lake water  
Ph.D. Thesis, University Toronto, Toronto, Ontario.  
192 p.
- Lean, D. R. S.-1973b- Phosphorus dynamics in lake water.  
Science. vol 179:678-680.
- Lin, Chang-Kwei.-1971- Availability of phosphorus for  
Cladophora growth in Lake Michigan. Proc. 14th Conf.  
Great Lakes. p. 39-43.
- Lovegrove, T.-1966- The determination of the dry weight  
of plankton and the effect of various factors on the  
values obtained. p.429-467. In Harold Barnes (ed.)  
Some Contemporary Studies in Marine Science. George  
Allen and Unwin Ltd., London. 719p.
- Lund, J.W.G., Kipling, C. and Le Cren, E.D.-1961-The  
inverted microscope method of estimating algal numbers  
and the statistical basis of estimating by counting.  
Hydrobiologia. 11:143-170.
- MacKereth, F. J.-1953-Phosphorus utilization by Asterionella  
formosa Hass. J. Exptl. Bot. 4:296-313.
- Marshall. S. M and Orr, A.P.-1955- The biology of a marine  
copepod. Springer-Verlag. 195p.
- Martin, J.-1968-Phytoplankton-zooplankton relationships  
in Narragansett Bay. III. Seasonal changes in zoo-  
plankton excretion rates in relation to phytoplankton  
abundance. Limnol. Oceanogr. 13(1):63-71.
- Menzel, D.W. and Corwin, N.-1965-The measurement of total  
phosphorus in seawater based on the liberation of

- organically bound fractions by persulfate oxidation.  
Limnol. Oceanogr. 10(2):280-282.
- Morowitz, H.J.- 1968 - Energy flow in biology. Biological organization as a problem in thermal physics. Academic Press. N.Y. 179 p.
- Nalewajko, C. and Lean, D.R.S.- 1972 - Retention of dissolved compounds by membrane filters as an error in the  $^{14}\text{C}$  method of primary production measurements. Jour. Phycology. 8:37-43.
- Nauwerk, A.- 1963 - Die Beziehungen zwischen Zooplankton und phytoplankton in See Erken. Synt. Bot. Appsal. 17(15):1-63.
- Peters, R.H.- 1972 - Phosphorus regeneration by zooplankton. Ph.D. Thesis, University of Toronto, Toronto, Ontario. 205 p.
- Peters, R.H. and Lean, D.R.S. - 1973 - The characterization of soluble phosphorus released by limnetic zooplankton. Limnol. Oceanogr. 18(2):270-279.
- Peters, R.H. and Rigler, F.A. - 1973 - Phosphorus release by Daphnia. Limnol. Oceanogr. 18(6):821-839.
- Pomeroy, L.R., Mathews, H.M. and Min, S.M.- 1963 - Excretion of phosphate and soluble organic phosphorus compounds by zooplankton. Limnol. Oceanogr. 8(1):50-55.

- Provasoli, L.- 1969 - Algal nutrition and eutrophication.  
p. 574-593. In Eutrophication: causes, consequences  
and correctives. Nat. Acad. of Sci., Wash. D.C. 661 p.
- Rhee, G-Yull.- 1971 - Competition between an alga and an  
aquatic bacterium for phosphate. Ph.D. Thesis, Cornell  
University, Ithaca, N.Y. 55 p.
- Rhee, G-Yull.- 1973 - A continuous culture study of phosphorus  
uptake, growth rate and polyphosphate in Scenedemus sp.  
J. Phycol. 9(4):495-506.
- Riggs, D.S.- 1963 - The mathematical approach to physiological  
problems. The M.I.T. Press, Cambridge. 445 p.
- Rigler, F.H.- 1956 - A tracer study of the phosphorus cycle  
in lake water. Ecology. 37:550-562.
- Rigler, F.H.- 1961 - The uptake and release of inorganic phos-  
phorus by Daphnia magna Straus. Limnol. Oceanogr.  
6(2):165-172.
- Rigler, F.H.- 1964a - The contribution of zooplankton to the  
turnover of phosphorus in the epilimnion of lakes.  
Can. Fish. Cult. 32:3-9.
- Rigler, F.H.- 1964b - The phosphorus fractions and the  
turnover time of inorganic phosphorus in different  
types of lakes. Limnol. Oceanogr. 9(4):511-518.
- Rigler, F.H.- 1973 - A dynamic view of the phosphorus cycle  
in lakes. p. 539-572. In E.J. Griffith et al., (eds.)  
Environmental Phosphorus Handbook. John Wiley & Sons,  
N.Y. 718 p.

- Saunders, G.W.- 1969 - Some aspects of feeding in zooplankton. p. 556-573. In Eutrophication; causes, consequences, correctives. Symposium. Nat. Acad. of Sci., Wash. D.C. 661 p.
- Schindler, D.W.- 1968 - Feeding, assimilation and respiration rates of Daphnia magna under various environmental conditions and their relation to production estimates. Jour. Animal Ecol. 37:369-385.
- Schindler, J.- 1971 - Food quality and zooplankton nutrition. Jour. Animal Ecol. 40:589-595.
- Shapiro, J.- 1973 - A field fixation technique for dissolved phosphate in lake water. Limnol. Oceanogr. 18(1):143-145.
- Shapiro, J., Chamberlain, W.M. and Barrett, J.- 1969 - Factors influencing phosphate use by algae. Proc. 4th. Intern. Conf. Water Poll. Res., Prague.
- Strickland, J.D.H.- 1960 - Measuring the production of marine phytoplankton. Bull. Fish. Res. Bd. Can., No. 122, 172 p.
- Strickland, J.D.H. and Parsons, T.R.- 1968 - A Practical Handbook of Seawater Analysis. Bulletin 167, Fish. Res. Bd. Can., Ottawa. p. 311.
- Zilversmit, D.B., Entenman, C. and Fishler, M.C.- 1943 - On the calculation of "turnover time" and "turnover rate" from experiments involving the use of labeling agents. J. Gen. Physiol. 26:325-331