

Spring 2004

# Analysis of signal output by the ethylene receptor ETR1 from Arabidopsis

Xiang Qu

*University of New Hampshire, Durham*

Follow this and additional works at: <https://scholars.unh.edu/dissertation>

---

## Recommended Citation

Qu, Xiang, "Analysis of signal output by the ethylene receptor ETR1 from Arabidopsis" (2004). *Doctoral Dissertations*. 217.  
<https://scholars.unh.edu/dissertation/217>

This Dissertation is brought to you for free and open access by the Student Scholarship at University of New Hampshire Scholars' Repository. It has been accepted for inclusion in Doctoral Dissertations by an authorized administrator of University of New Hampshire Scholars' Repository. For more information, please contact [nicole.hentz@unh.edu](mailto:nicole.hentz@unh.edu).

**ANALYSIS OF SIGNAL OUTPUT BY THE ETHYLENE RECEPTOR ETR1  
FROM *ARABIDOPSIS***

BY

XIANG QU  
B.S., Wuhan University, 1996

DISSERTATION

Submitted to the University of New Hampshire  
in Partial Fulfillment of  
the Requirements for the Degree of

Doctor of Philosophy

in

Biochemistry

May, 2004

UMI Number: 3132798

### INFORMATION TO USERS

The quality of this reproduction is dependent upon the quality of the copy submitted. Broken or indistinct print, colored or poor quality illustrations and photographs, print bleed-through, substandard margins, and improper alignment can adversely affect reproduction.

In the unlikely event that the author did not send a complete manuscript and there are missing pages, these will be noted. Also, if unauthorized copyright material had to be removed, a note will indicate the deletion.

**UMI**<sup>®</sup>

---

UMI Microform 3132798

Copyright 2004 by ProQuest Information and Learning Company.

All rights reserved. This microform edition is protected against unauthorized copying under Title 17, United States Code.

ProQuest Information and Learning Company  
300 North Zeeb Road  
P.O. Box 1346  
Ann Arbor, MI 48106-1346

This dissertation has been examined and approved.

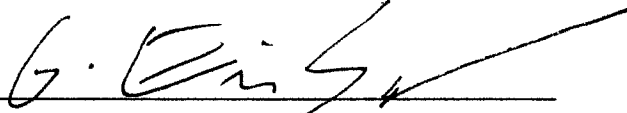

Dissertation Director, G. Eric Schaller,  
Associate Professor of Biochemistry and Molecular  
Biology and Genetics

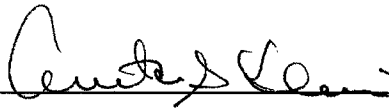

Anita S. Klein,  
Associate Professor of Biochemistry and Molecular  
Biology and Genetics, Chair of Biochemistry and  
Molecular Biology

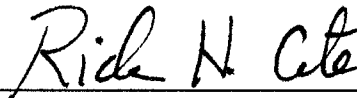

Rick H. Cote,  
Professor of Biochemistry and Molecular Biology



John J. Collins,  
Associate Professor of Biochemistry and Molecular  
Biology and Genetics



Estelle M. Hrabak  
Associate Professor of Plant Biology and Genetics

April 21, 2004

Date

## DEDICATION

This dissertation is dedicated to my wife, Sheen Lu, who gives me such a wonderful world filled with her endless love. I also dedicate this dissertation to my parents, Songbai Qu and ShanShan Liu, for their patience, love, and support during my studies as well as all the difficult times of my life.

## ACKNOWLEDGEMENTS

I would like to thank everyone here who contributed to the success of this research. First, my sincere thanks to Dr. G. Eric Schaller, my dissertation advisor. This work would have been impossible without his guidance and assistance. During my six-year study, his scientific curiosity and academic expertise continuously served as both stimulus and encouragement. I would also like to thank other members of my dissertation committee, Dr. Anita S. Klein, Dr. Rick H. Cote, Dr. John J. Collins, and Dr. Estelle M. Hrabak for their constant support and encouragement, and scientific advice. A special thank is also extended to Dr. Thomas M. Davis, my former committee member. I thank all members of the Schaller lab, especially Dr. Dennis E. Mathews who did the initial screens for the T-DNA insertion mutations in ethylene receptors and critically read this dissertation, Rebekah L. Gamble who initiated the study of the histidine kinase domain of ETR1, and Michael Jose who is the “go-to” guy whenever I need a favor. I also thank the Hrabak lab and the Minocha lab for generously letting me use their equipment. I appreciate the support and friendship of all the faculty members and graduate students in the Biochemistry and Molecular department. Finally, I thank my wife, Sheen Lu, who shines my life.

This work was supported in part by grants from the National Science Foundation (grant nos. MCB-9603679, MCB-9982510, and DBI-9975908 to G.E.S.), and by a Dissertation Fellowship awarded to X.Q. from the UNH Graduate School.

## TABLE OF CONTENTS

DEDICATION.....	iii
ACKNOWLEDGEMENTS .....	iv
LIST OF FIGURES.....	vii
LIST OF TABLES.....	ix
ABSTRACT .....	x
CHAPTER	PAGE
I. GENERAL INTRODUCTION.....	1
II. THE HISTIDINE KINASE DOMAIN OF ETR1 IS REQUIRED FOR ETHYLENE SIGNALING IN <i>ARABIDOPSIS</i> .....	22
Abstract .....	22
Introduction .....	23
Materials and Methods .....	25
Results .....	30
Discussion .....	41
III. HISTIDINE KINASE ACTIVITY PLAYS A ROLE IN THE ESTABLISHMENT OF ETHYLENE RESPONSES IN <i>ARABIDOPSIS</i> .....	49
Abstract .....	49
Introduction .....	50
Materials and Methods .....	52

Results .....	60
Discussion .....	77
IV. SUMMARY .....	83
Conclusions .....	83
Future Directions .....	88
LIST OF REFERENCES.....	94
APPENDICES.....	103



## LIST OF FIGURES

### CHAPTER I

Figure 1.	Ethylene biosynthetic pathway .....	6
Figure 2.	Ethylene-induced triple response of dark-grown (etiolated) <i>Arabidopsis</i> seedlings .....	8
Figure 3.	The ethylene signaling pathway in <i>Arabidopsis</i> .....	10
Figure 4.	The <i>Arabidopsis</i> ethylene receptor family .....	11
Figure 5.	Structure of the ethylene receptor ETR1 .....	13
Figure 6.	Negative regulation of ethylene responses by the ethylene receptor ETR1 .....	15
Figure 7.	Proposed model of signal output by the ethylene receptor ETR1 in <i>Arabidopsis</i> .....	19

### CHAPTER II

Figure 8.	Effect of loss-of-function mutations in <i>ETR1</i> upon its expression.....	31
Figure 9.	Effect of the ETR1-FL receptor upon the triple response of the <i>etr1-6;etr2-3;ein4-4</i> dark-grown seedlings .....	34
Figure 10.	Experimental strategy and constructs used for experimental analysis ...	36
Figure 11.	Effect of the ETR1(1-349) mutant receptor upon the triple response ....	37
Figure 12.	Effect of the ETR1(1-603) mutant receptor upon the triple response ....	40
Figure 13.	Effect of the ETR1(G2) mutant receptor upon the triple response .....	42

### CHAPTER III

Figure 14.	Structure of ETR1 and constructs used for experimental analysis .....	59
Figure 15.	Analysis of the T-DNA insertion mutant <i>ers1-2</i> .....	61
Figure 16.	<i>etr1-9</i> and <i>ers1-3</i> are null mutant alleles of <i>ETR1</i> and <i>ERS1</i> .....	64

Figure 17.	Phenotypic analysis of the T-DNA insertion mutant alleles of <i>ETR1</i> and <i>ERS1</i> .....	66
Figure 18.	Ethylene dose response curves of hypocotyl growth for the <i>etr1-7</i> , <i>etr1-9</i> , <i>ers1-2</i> , and <i>ers1-3</i> mutants .....	67
Figure 19.	Effects of <i>etr1</i> and <i>ers1</i> mutations upon plant growth .....	69
Figure 20.	Effect of ACC upon growth of wild-type <i>Columbia</i> (COL) and the <i>ctr1-2</i> mutant .....	71
Figure 21.	Genotyping and the skotomorphological features of the progeny with partial ethylene insensitivity from the cross between <i>ers1-3</i> and a transgenic <i>etr1-7</i> line carrying the <i>ETR1(G2)</i> transgene .....	75

#### CHAPTER IV

Figure 22.	A model of ethylene signaling by the ethylene receptor ETR1 via regulation of CTR1 activity .....	85
------------	---	----

## LIST OF TABLES

### CHAPTER III

Table 1.	Ethylene effect upon shoot formation .....	72
----------	--	----

## ABSTRACT

### ANALYSIS OF SIGNAL OUTPUT BY THE ETHYLENE RECEPTOR ETR1 FROM *ARABIDOPSIS*

By

Xiang Qu

University of New Hampshire, May, 2004

Ethylene is one of the most important plant hormones and regulates many processes during plant growth and development. In *Arabidopsis*, the ethylene receptor family consists of five members: ETR1 and ERS1 have a functional histidine kinase domain and form subfamily 1; members of subfamily 2, including ETR2, ERS2, and EIN4, possess a highly diverged histidine kinase domain predicted not to be functional. To analyze signal output by the ethylene receptor ETR1 from *Arabidopsis*, mutant-based approaches were taken. Initially, the role of the proposed signal output region of ETR1 in ethylene signaling was examined. For this purpose, the ability of mutant versions of ETR1 to rescue the constitutive response phenotype of the *etr1-6;etr2-3;ein4-4* triple loss-of-function mutant line was examined. A truncated version of ETR1 that lacks both the histidine kinase domain and the receiver domain failed to rescue the triple mutant phenotype. A truncated ETR1 receptor that lacks only the receiver domain restored normal growth to the triple mutant in air, but the transgenic seedlings displayed hypersensitivity to ethylene. A mutation that eliminated histidine kinase activity had a modest effect upon the ability of the receptor to repress ethylene responses in air. These results demonstrate that the histidine kinase domain is required for the repression of ethylene responses. To further address whether histidine kinase activity is required for

ethylene signaling, single loss-of-function allele of *ERS1* was isolated and *ers1;etr1* double null mutants were generated. The *ers1;etr1* double mutants displayed a constitutive ethylene response phenotype when grown in the dark, and were dwarfed with small and epinastic leaves in the air and died without bolting when grown under light. The phenotype of *ers1;etr1* is more profound than that observed in the *etr2-3;ein4-4;ers2-3* triple loss-of-function mutant reported previously, indicating that subfamily 1 members (ETR1 and ERS1) play a predominant role in ethylene signaling. Addition of the kinase-inactivated ETR1(G2) into a background containing both *ers1-3* and *etr1-7* mutations results in ethylene insensitivity, demonstrating that the histidine kinase activity of ETR1 may play a role in the establishment of ethylene responses.

## CHAPTER I

### GENERAL INTRODUCTION

Battling for their survival, all living organisms on this planet have to sense and interact with their environment. This is particularly crucial for plants, which are immobile and anchored in position and must endure whatever environment they experience. Abiotic factors, such as light, temperature and water, play critical roles during plant growth and development. To adapt to their local environment, plants have developed sophisticated sensory apparatus and signal-transduction systems by which they can sense and integrate these signals, and then reach a finely balanced decision as to how to grow and develop to most successfully survive and exploit the environment. External and internal signals are monitored by plants. Hormones play a central role in regulating plant growth and development. In general, plant hormones serve as internal signals, which respond to the environment and ultimately lead to regulated growth and developmental responses accordingly. During the past few decades, most research on hormones has been focused on the biosynthesis of hormones and on the hormone receptors. We now have a growing but still very limited knowledge of the molecular basis of plant hormone signaling. The main purpose of my Ph.D. research is to advance our understanding of a fundamental unanswered question in ethylene signaling – how ethylene receptors transduce the signal, once they perceive ethylene. For this purpose, I analyzed the ethylene receptor ETR1 genetically, biochemically and physiologically in the model plant, *Arabidopsis*.

### **Arabidopsis, a plant model system**

Commonly known as mouse-eared cress, *Arabidopsis* is a small flowering relative of the mustard plant (e.g. broccoli and cauliflower). Because of its small size (about 30 centimeters in height), short life cycle (2 to 3 months to go from seed to seed), prodigious seed production (with an average yield of 10,000 seeds per plant), and a relatively small genome size (125Mb) compared to other higher plants (2,500Mb in maize and 16,000 Mb in wheat) (The *Arabidopsis* Genome Initiative, 2000), *Arabidopsis* has become a model system for plant laboratory research since 1980s (Meyerowitz and Pruitt, 1985; Meyerowitz, 2001).

With the genome sequence of *Arabidopsis* completed by the *Arabidopsis* Genome Initiative (AGI) in 2000, *Arabidopsis* serves as an excellent organismal system for sophisticated studies in genetics and genomics (The *Arabidopsis* Genome Initiative, 2000). By this point, its uses in modern genetics are all well-known. These include saturation mutagenesis screens, enhancer trapping and activation trapping mutagenesis, its utility in gene mapping (with full sets of publicly available SNPs, AFLP markers, and CAPS markers) (Rhee et al., 2003), the ease of gene cloning by insertional mutagenesis or map-based cloning (Feldmann KA, 1989; Arondel et al., 1992; Giraudat et al., 1992; Alonso et al., 2003), the possibilities of full-genome array analysis (aided by complete physical maps and a completed and well-annotated genome sequence in public databases) (Kim et al., 2003), and sophisticated phenotypic screens (with full arrays of cell-type specific reporter genes, both fluorescent and enzymatic) (Budziszewski et al., 2001).

It is worth comparing the utility of this plant system to animal systems of comparable genetic sophistication, such as *Drosophila melanogaster* and *Caenorhabditis*

*elegans*. Plants are much harder to kill than animals, due to the absence any vital organs. Furthermore, *Arabidopsis*, though a small plant, is much larger than a fly or nematode worm like *C. elegans*, and like any plant, all of its living cells are totipotent and culturable (Wu et al., 1992; O'Neill and Mathias, 1993). These qualities make it possible to obtain more than sufficient amounts of biological compounds, such as RNA, DNA, and protein, from specific tissues and specific cell types without great effort. It is also increasingly clear that information on developing plant systems may be of use in understanding cognate processes in animals (and vice versa), because many of the specific molecular and cellular processes are the same in plants and animals (Meyerowitz, 2002). At the same time, plants represent the system of complex multicellular development that, in evolutionary terms, is the most distant one known from animals (Meyerowitz, 2002).

### **Ethylene, a gaseous plant hormone**

There are five major phytohormones identified in plants: auxin, gibberellin (GA), ethylene, cytokinin, and abscisic acid (ABA) (Kende and Zeevaart, 1997). These are considered the classical plant hormones because their role in plant development was established decades ago. Among them, ethylene ( $H_2C=CH_2$ ) is the simplest one – a gaseous molecule with a bi-hydrocarbon structure. Long before it was recognized as an endogenous plant growth regulator, ethylene was already known to cause defoliation of nearby trees due to leaking “illuminating gas” used in lighting of the mid-nineteenth century (Neljubow, 1901). Despite its simple structure, ethylene is now recognized as one of the most important plant hormones and plays a critical role during plant growth and



development (Abeles et al., 1992). Exposure to ethylene produces many profound effects upon plant growth and development, including most notably stimulation of fruit ripening, inhibition of shoot and root elongation, stimulation of seed germination and flowering, and sex determination in some monoecious plants (Abeles et al., 1992; Johnson and Ecker, 1998).

One of the earliest observations indicating that ethylene functioned as a plant hormone was the discovery by Cousins that a gas released from oranges stimulated the premature ripening of banana (Cousins, 1910). It was later demonstrated by Gane in 1934 that the gas was ethylene (Gane, 1934). This was the first direct evidence that plants produce ethylene themselves. Later discoveries indicated that plants can produce ethylene from almost all their tissues, including leaves, flowers, roots, and stems (Kende, 1993). More intriguingly, plant ethylene production is tightly regulated by developmental events, such as germination and senescence (Yang and Hoffman, 1984; Abeles et al., 1992), as well as in response to abiotic and biotic environmental stimuli, such as drought, extreme temperature, and tissue lesions caused by pathogens (Botella et al., 1995; Liang et al., 1996; Woeste, 1999). Obviously, plants precisely control their ethylene production so as to elicit an optimal physiological, growth, or developmental response.

Soon after the first recognition of the biological role of ethylene, numerous efforts were devoted to elucidating the ethylene biosynthetic pathway. However, the molecular basis of ethylene biosynthesis was not completely unraveled until 1979 when Adams and Yang provided evidence that ethylene is formed from methionine via *S*-adenosyl-L-methionine (AdoMet) and the cyclic non-protein amino acid 1-aminocyclopropane-1-carboxylic acid (ACC) (Yu et al., 1979). The ethylene biosynthetic pathway contains

several enzymatic steps as shown in Figure 1 (Schaller and Kieber, 2002). First, AdoMet synthetase catalyzes the conversion of methionine to AdoMet. Then, the formation of the ethylene precursor ACC is catalyzed by ACC synthase (ACS). This is the key regulatory step in ethylene biosynthesis. Meanwhile, 5'-methylthioadenosine (MTA) is also produced at this step. MTA then enters the methionine cycle to convert back to methionine (Miyazaki and Yang, 1987). This allows plants to constantly maintain a pool of free methyl groups for another round of ethylene biosynthesis. The final step in ethylene biosynthesis is catalyzed by ACC oxidase (ACO), which converts ACC to ethylene (Yu et al., 1979).

### **Ethylene signal transduction**

The ethylene response, like other hormone-induced responses, can be regulated at two different stages: (1) hormone biosynthesis which determines where, when and how much hormone is produced; and (2) signal transduction which includes hormone perception and the signal cascade. Since 1967 when ethylene signaling was first proposed by Burg (Burg and Burg, 1967), the ethylene signaling pathway has been extensively studied. However, it was not until the last decade that researchers started to succeed in identifying receptors and other signaling components in the primary ethylene signal-transduction pathway by use of modern molecular and genetic applications in *Arabidopsis*.

Ethylene and its biosynthetic precursor ACC have a profound impact upon the growth of dark-grown (etiolated) seedlings (Guzman and Ecker, 1990). It inhibits the hypocotyl and root elongation of etiolated seedlings, induces the swelling of the stem,

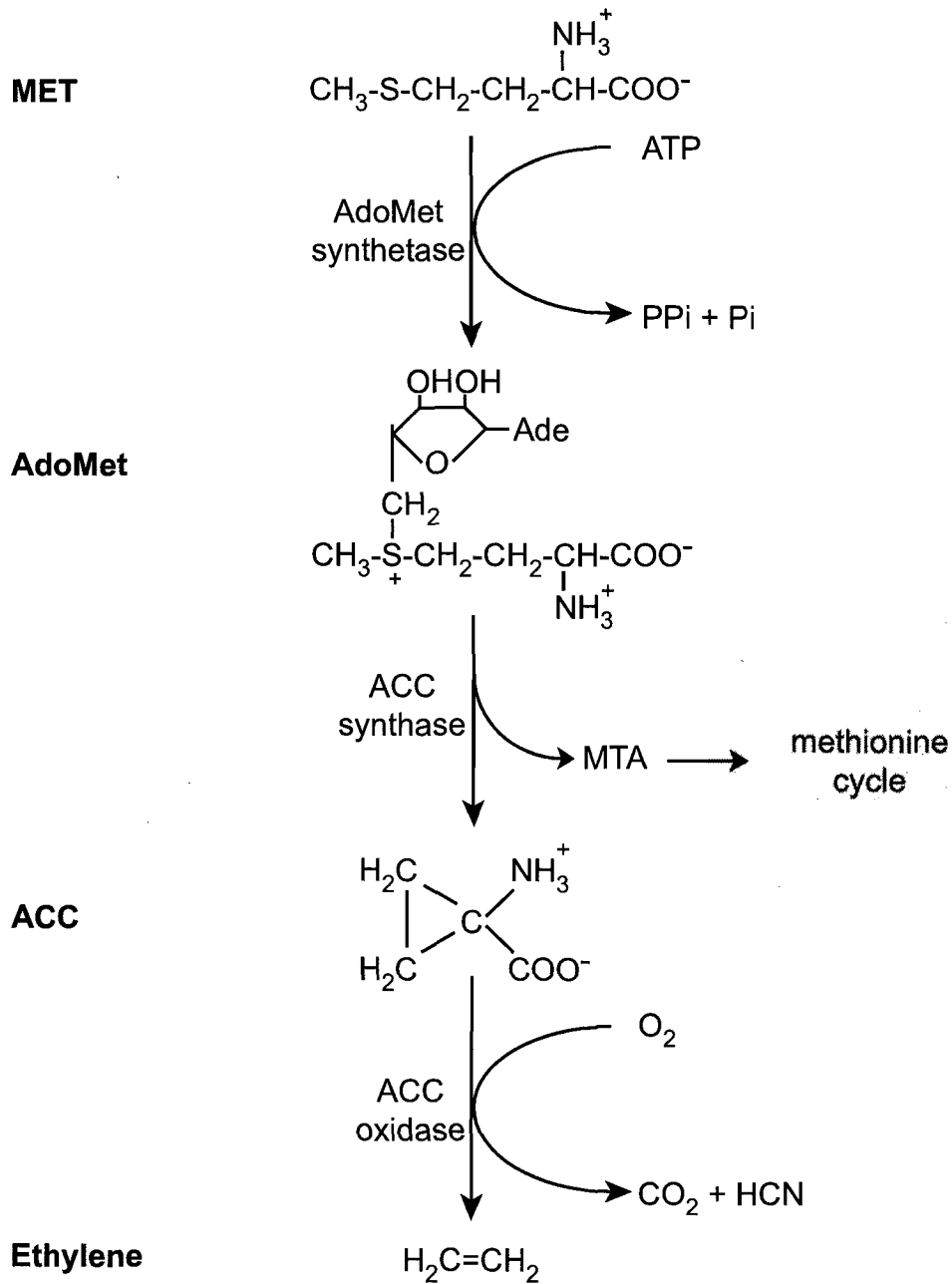

**Figure 1.** Ethylene biosynthetic pathway (modified from Schaller and Kieber, 2002). The enzymes catalyzing each step are shown at the left side of the arrows. AdoMet: S-adenyl-methionine; ACC: 1-aminocyclopropane-1-carboxylic acid; MTA: methylthiodenine.

and tightens the closure of the apical hook (Figure 2). This ethylene-induced seedling growth response is called the “triple response” (Guzman and Ecker, 1990). It serves as a simple but powerful tool to identify mutants with defects in ethylene signaling. Two major types of ethylene mutants have been identified: ethylene-insensitive mutants which display an air-grown phenotype in the presence of ethylene, and constitutive ethylene response mutants which display an ethylene-induced growth phenotype even in the absence of ethylene (Guzman and Ecker, 1990). Over the last decade, many components in the ethylene signaling pathway were identified by mutant screens based on the ethylene-induced triple response (Chang et al., 1993; Kieber et al., 1993; Lehman et al., 1996; Hua et al., 1998; Alonso et al., 1999). One of those components is *CTR1*, which is a negative regulator of ethylene responses due to the fact that the loss-of-function *ctr1* mutations result in constitutive ethylene responses (Kieber et al., 1993). *CTR1* shares strong sequence similarity with the Raf family of serine/threonine protein kinases (Kieber et al., 1993). In animals, the Raf-like protein kinase is involved in the mitogen-activated protein kinase (MAPK) cascade. Double mutant analysis demonstrated that *CTR1* acts downstream of a family of genes carrying dominant ethylene insensitive mutations (*etr1*, *ers1*, *etr2*, *ers2*, and *ein4*) (Kieber and Ecker, 1993; Hua et al., 1995; Roman et al., 1995; Hua et al., 1998; Sakai et al., 1998). Downstream of *CTR1*, there is *EIN2* which encodes a transmembrane protein related to the Nramp metal transporter family (Alonso et al., 1999). Loss-of-function mutations in *EIN2* lead to strong ethylene insensitivity, indicating that *EIN2* is a positive regulator of ethylene transduction. A further downstream positive regulator, *EIN3*, is thought to act together with three additional *EIN3*-like proteins (*EILs*) as transcriptional activators. These activate the expression of



**Figure 2.** Ethylene-induced triple response of dark-grown (etiolated) *Arabidopsis* seedlings. Wild-type seedling grown in the absence of ethylene (left) or in the presence of ethylene (right).

ERF1, a member of another transcription factor family involved in ethylene signaling (Ohme-Takagi and Shinshi, 1995; Chao et al., 1997; Riechmann and Meyerowitz, 1998; Solano et al., 1998; Fujimoto et al., 2000). As shown in Figure 3, researchers have developed a growing but still incomplete model of the ethylene signaling pathway based on these findings (Schaller and Kieber, 2002).

### **Ethylene receptors, negative regulators of the ethylene signaling pathway**

In *Arabidopsis*, there are five members of the ethylene receptor family: ETR1, ERS1, ETR2, ERS2 and EIN4 (Chang et al., 1993; Hua et al., 1995; Hua et al., 1998; Sakai et al., 1998). All five receptor members have strong sequence similarities and similar protein structures: all of them contain three transmembrane domains and a GAF domain at the N-terminal region. On the other hand, they also have distinct features: ETR1 and ERS1 have a highly conserved histidine kinase domain (Chang et al., 1993; Hua et al., 1995), while other members contain a diverged domain predicted to lack histidine kinase activity (Hua et al., 1998; Sakai et al., 1998). Furthermore, only ETR1, ETR2 and EIN4 possess a receiver domain at their C-terminal region (Chang et al., 1993; Hua et al., 1998; Sakai et al., 1998). Based on their protein sequence and structure, ethylene receptors are divided into two subgroups (Schaller and Kieber, 2002): subgroup one consists of ETR1 and ERS1; and subgroup two consists of ETR2, ERS2, and EIN4 (Figure 4).

As the first identified ethylene receptor, ETR1 is the best characterized member of the family (Figure 5). The amino-terminal region of ETR1 consists of three transmembrane domains which confer the ethylene binding ability (Schaller and Bleecker,

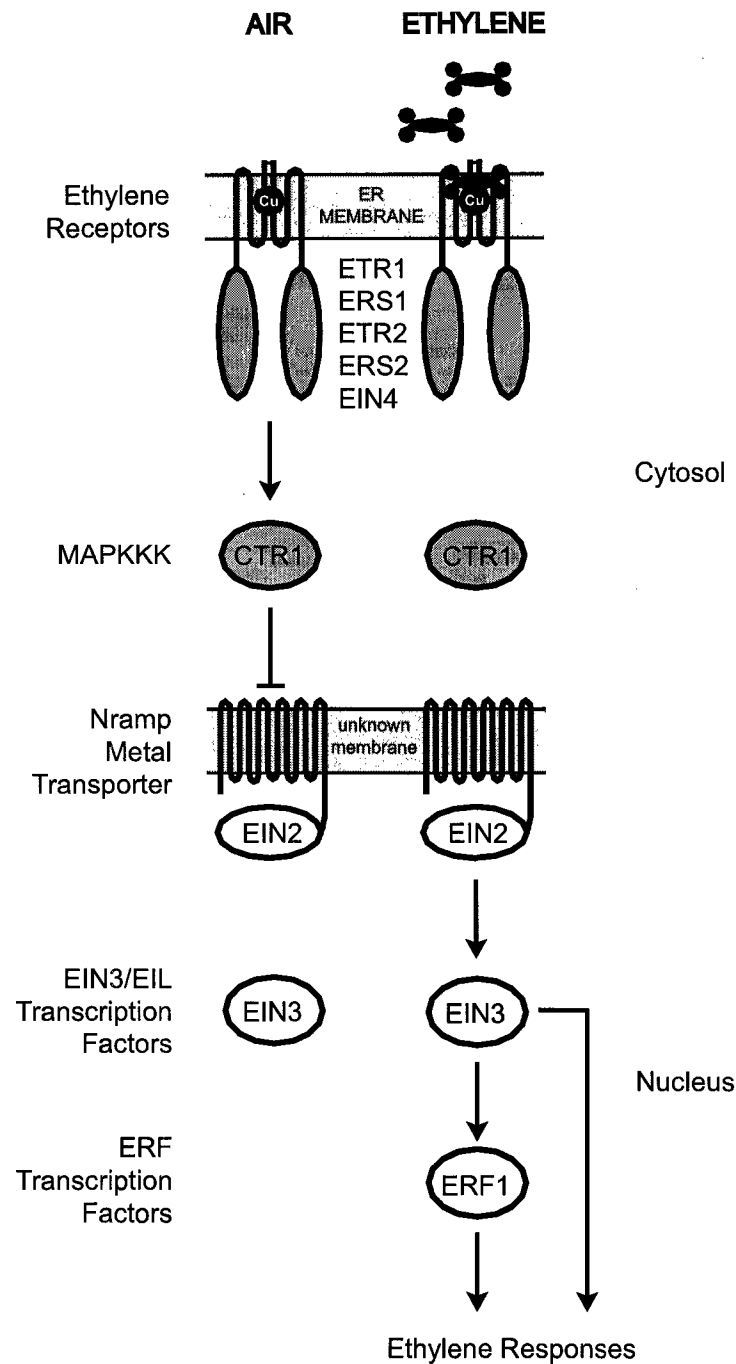

**Figure 3.** The ethylene signaling pathway in *Arabidopsis* (modified from Schaller and Kieber, 2002). Signaling components involved in ethylene signal transduction are indicated. In the absence of ethylene (AIR), ethylene receptors are in a signaling active state and actively repress ethylene responses via activation of CTR1. In the presence of ethylene, binding of ethylene inactivates ethylene receptors, which in turn results in inactivation of CTR1. As a result, EIN2 is activated and a transcriptional cascade mediated by the EIN3/EIL and ERF transcription factors is initiated.

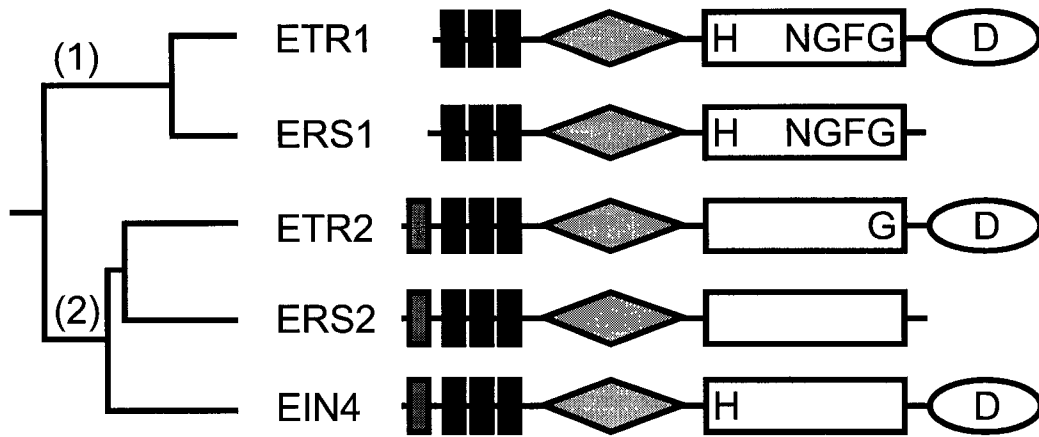
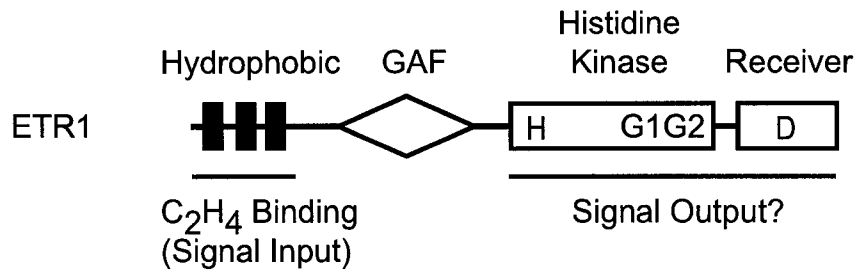

**Figure 4.** The *Arabidopsis* ethylene receptor family (modified from Schaller and Kieber, 2002). Primary structural features of the five-member receptor family are indicated. Grey boxes represent putative signal sequences. Black boxes represent transmembrane domains. Grey diamonds represent GAF domains with unknown function. Rectangles represent histidine kinase domains. Ovals represent receiver domains. H and D indicate the conserved phosphorylation sites. Conserved motifs (NGFG) within the histidine kinase domain are indicated if present. Based on protein structure and phylogenetic analysis, the ethylene receptor family is further divided into two subgroups: subfamily 1 and subfamily 2.



1995). Both ETR1 and ERS1 have been observed to form homodimers *in vivo* via disulfide bond linkages between cysteine residues near the amino-terminus of the receptor (Schaller et al., 1995). Since all of the other four ethylene receptor members contain cysteine residues at the same region, it is generally accepted that ethylene receptors function as a dimer. The evidence that both ETR1 and ERS1 possess ethylene-binding capacity demonstrated their characteristics to be those of an ethylene receptor (Schaller and Bleeker, 1995; Hall et al., 2000). In addition, missense mutations within the hydrophobic sensory region of any of the five ethylene receptors usually result in ethylene insensitivity (Bleeker et al., 1988; Chang et al., 1993; Hua et al., 1995; Hua et al., 1998; Sakai et al., 1998).

The carboxy-terminal half of the receptor includes a histidine kinase domain and a putative receiver domain (Chang et al., 1993), motifs originally identified in the well-characterized bacterial two-component system (Parkinson, 1993). In bacteria, this system is involved in such diverse processes as chemotaxis, osmotic sensing, and light perception (Stock et al., 2000). Two-component systems usually consist of two elements: (1) a sensor histidine kinase which autophosphorylates at a histidine residue upon perception of environmental signals, and (2) a response regulator with a conserved receiver domain that receives a phosphate group transferred from the histidine kinase. The phosphorylated response regulator then regulates the downstream signaling components (Stock et al., 2000). Since the biochemistry of two-component systems is that of a phosphorelay from a histidine residue to an aspartate residue, this type of signaling mechanism is also referred as the His-to-Asp phosphorelay (Stock et al., 2000).



**Figure 5.** Structure of the ethylene receptor ETR1. The hydrophobic domain, the GAF domain, the histidine kinase domain, and the receiver domain are indicated. H represents the histidine residue at position 353, which is the autophosphorylation site. G1 and G2 represent G1 and G2 boxes, which are ATP-binding sites. D represents the aspartate residue at position 659, which is the putative phosphorylation site within the receiver domain.

Results from *in vitro* phosphorylation experiments in a yeast expression system demonstrated that ETR1 possesses histidine kinase activity (Gamble et al., 1998).

ETR1 also contains a GAF domain. GAF domains are ubiquitous motifs present in cyclic GMP (cGMP)-regulated cyclic nucleotide phosphodiesterases, certain adenylyl cyclases, the bacterial transcription factor FhlA, and hundreds of other signaling and sensory proteins from all kingdoms of life (Aravind and Ponting, 1997). However, the role of GAF domains in ethylene signaling has not been determined.

Genetic and biochemical analyses of the ethylene receptors have allowed us to see a section from the whole picture of ethylene signal transduction. Loss-of-function mutations have been isolated for four members of the ethylene receptor family, including *ETR1*, *ETR2*, *ERS2* and *EIN4* (Hua and Meyerowitz, 1998). Transgenic lines containing a single loss-of-function mutation have wild-type-like ethylene responses, while the mutant plants with triple or quadruple loss-of-function mutations show constitutive ethylene responses (Hua and Meyerowitz, 1998). These results indicate that ethylene receptors have redundant functions in ethylene signaling (Hua and Meyerowitz, 1998). In addition, elimination of receptors results in constitutive activation of ethylene responses. This result demonstrates that ethylene receptors negatively regulate ethylene signal transduction (Hua and Meyerowitz, 1998). In air, ethylene receptors are in a signaling active state and repress ethylene responses. Upon binding of ethylene, receptors switch to a signaling inactive state, which relieves the repression on the ethylene pathway (de-repression) (Figure 6).

Dominant ethylene-insensitive mutations of the receptors have also been isolated by screening dark-grown seedlings in the presence of ethylene. All these mutants result

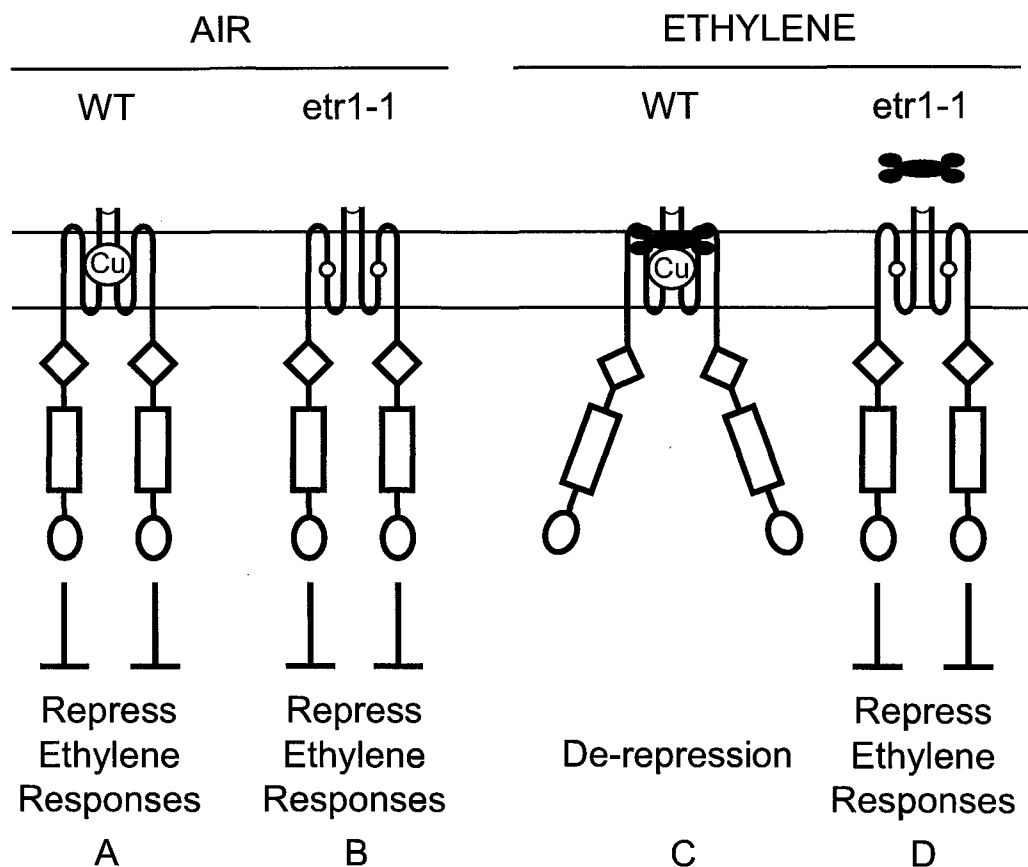

**Figure 6.** Negative regulation of ethylene responses by the ethylene receptor ETR1. The ethylene receptor ETR1 forms a homodimer via the disulfide bond linkage. Each homodimer contains one ethylene-binding site. A metal ion cofactor, copper (Cu), is required for ethylene binding. In air, receptors actively repress ethylene responses (**A** and **B**). In presence of ethylene, the wild-type receptor ETR1 is inactivated, thereby relieving repression of ethylene responses (**C**). The *etr1-1* mutation eliminates binding of the required copper (Cu) cofactor. The *etr1-1* mutant receptor is still in active signaling state even in presence of ethylene, thereby actively repressing ethylene responses (**D**).

from single amino acid substitutions within the hydrophobic region of the receptors. Evidence indicates that these single mutations either abolish the ethylene binding ability of the receptor or uncouple ethylene perception from signal output (Chang et al., 1993; Hall et al., 1999; Rodriguez et al., 1999). *etr1-1*, a dominant ethylene-insensitive mutant allele of *ETR1*, results from a single amino acid substitution (Cys65Tyr) in its ethylene-binding site (Chang et al., 1993). It has been demonstrated that the mutant receptor *etr1-1* loses its ability to bind a copper cofactor which is essential for ethylene binding (Rodriguez et al., 1999). Similar mutations within the ethylene-binding site of other ethylene receptors also lead to dominant ethylene insensitivity. The ethylene-insensitive mutants are considered gain-of-function because their phenotype is the opposite of that seen with loss-of-function mutants. These ethylene-insensitive mutations apparently lock the receptors in the signaling active state, resulting in the repression of ethylene responses in both the presence and absence of ethylene (Figure 6).

### **Interaction between ethylene receptors and CTR1**

CTR1, a MAPKKK (Mitogen-Activated Protein Kinase Kinase Kinase)-like protein acting downstream of ethylene receptors, interacts with ETR1, ERS1, and ETR2 directly in the yeast two-hybrid and *in vitro* binding experiments (Kieber et al., 1993; Clark et al., 1998; Cancel and Larsen, 2002). It has also been demonstrated that ETR1 can interact with CTR1 through its histidine kinase domain as well as its receiver domain (Clark et al., 1998). More interestingly, the amino-terminal region of CTR1, which is the putative regulatory domain for the kinase activity of CTR1, is required for the association with ETR1 (Clark et al., 1998). In addition, the kinase activity of CTR1 is required for

ethylene signaling since mutations in the highly conserved residues within the kinase domain of CTR1 (e.g. *ctr1-1* and *ctr1-4*) result in constitutive ethylene responses (Huang et al., 2003). CTR1, which is a soluble protein, is recruited to the endoplasmic reticulum (ER) membrane as a result of interaction with ethylene receptors (Gao et al., 2003). Direct evidence also indicated that CTR1 is part of an ethylene receptor signaling complex in *Arabidopsis* and supported a model in which localization of CTR1 to the endoplasmic reticulum is necessary for its function (Gao et al., 2003). Therefore, the ethylene signal could be transferred from ethylene receptors to CTR1 as means of regulating the activity of CTR1 enzymatically or allosterically by ETR1 through its signal output domain. These results also suggest a distinctive signaling mechanism – the two-component system, originally in prokaryotes, integrates with a eukaryotic mitogen-activated protein kinase (MAP kinase) cascade. More strikingly, yeast uses a similar signaling mechanism to monitor low osmotic stress. In this system, the low osmolarity signal is perceived by a hybrid His kinase osmosensor SLN1, then transduced to the SSK2/22 MAPKKK through a multi-step phosphorelay (Ota and Varshavsky, 1993; Maeda et al., 1994; Maeda et al., 1995; Posas et al., 1996).

### **Hypothesis and significance**

Our knowledge of the molecular basis of how ETR1 acts as an ethylene receptor is growing, but is still far from complete. We know that the hydrophobic N-terminal region (signal input domain) of ETR1 plays a critical role in both conferring the ethylene binding ability and endoplasmic reticulum (ER) membrane localization of the receptor (Schaller and Bleecker, 1995; Chen et al., 2002). However, we do not know how the

ethylene stimulus is transmitted from the ethylene receptor ETR1 to the downstream signaling components of the ethylene signaling pathway. We also do not know where the signal output domain is located in the receptor – whether the signal input domain itself is sufficient for ETR1 to output the ethylene signal, or whether the cytosolic region (including the histidine kinase domain and the receiver domain) is responsible for signal output. Meanwhile, we know that ETR1 interacts with CTR1 so as to regulate the activity of CTR1. However, we do not know the molecular mechanism by which the activity of CTR1 is regulated by ETR1 (Figure 7). Furthermore, we have confirmed histidine kinase activity of ETR1 *in vitro* (Gamble et al., 1998). However, we do not have any clue about its physiological significance in ethylene signaling. We also do not have any direct evidence to support the hypothesis that ETR1 utilizes its kinase activity to act as an output of the ethylene signal. Interestingly, many other receptor kinases in *Arabidopsis* are similarly poorly studied – examples are CLV1 in shoot and flora meristem formation (Clark et al., 1997), PhyB in red/far red light perception (Krall and Reed, 2000), and BRI1, the steroid hormone receptor in plants (Li and Chory, 1997). All of these proteins possess a functional kinase domain, however, none of them has direct evidence supporting the role of their proposed kinase activity, and indeed in some cases, the kinase activity is dispensable (Matsushita et al., 2003). This has become a big question now – how do plant receptors utilize their kinase activity? It may even be that the kinase domains of those receptors are just an evolutionary byproduct, without direct function in signal transduction.

The main purpose of my Ph.D. research is to address these fundamental questions in ethylene signal transduction. My hypothesis is that the cytosolic domain of the

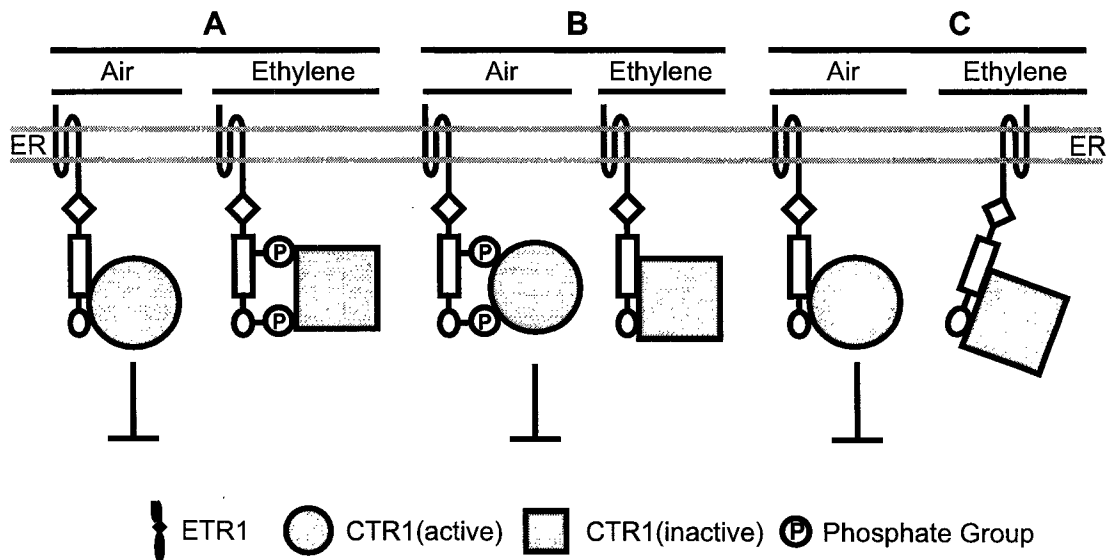

**Figure 7.** Proposed model of signal output by ethylene receptor ETR1 in *Arabidopsis*. For simplicity, only a single monomer of the ETR1 dimer is shown. CTR1 interacts with ETR1 through both the histidine kinase domain and the receiver domain. Two potential mechanisms could be used to regulate the activity of CTR1: an enzymatic mechanism, in which the phosphorylation state of ETR1 plays a crucial role in regulation of the CTR1 activity (A, B); or an allosteric mechanism, in which the activity of CTR1 is regulated by ethylene-induced conformational changes of ETR1 (C).



ethylene receptor ETR1, through action of its histidine kinase activity, plays an important role in signal output.

Chapter II of this dissertation describes results from experiments which addressed whether the proposed signal output domain of ETR1 is required for signaling. Initially, four independent loss-of-function mutant alleles of *ETR1* were analyzed. Each of these contains a point mutation that would theoretically result in a truncated receptor being produced. Expression of individual mutant receptors was quantified at both mRNA and protein levels. The latter part of this chapter describes another mutant-based approach to determine the specific region of ETR1 that is required for the signal output. A triple null mutant line, which lacks three out the five members of the ethylene receptor family, was used as background. Mutant versions of the ETR1 receptor were then transformed into this background and analyzed for their ability to rescue the triple mutant phenotype. Protein expression levels of mutant receptors in the triple mutant background were quantified. Physiological analyses, including ethylene dose response curve and triple response analysis, were conducted to determine the effect of each mutant receptor upon signal output.

Chapter III focuses on the question as to whether histidine kinase activity of ETR1 is required for ethylene signaling. Because ETR1 and ERS1 are the only members of the ethylene receptor family that contain the highly conserved histidine kinase domain, a double null mutant background that lacks both ETR1 and ERS1 is essential to address this question. T-DNA insertional mutant alleles in both genes were identified and characterized biochemically and physiologically. *etr1;ers1* double mutant lines were also generated, characterized, and compared. ETR1 mutants lacking essential residues for the

histidine kinase activity and/or phosphorylation sites were generated and transformed into the double mutant background. Results from initial experiments support a role for histidine kinase activity of ETR1 in the establishment of ethylene responses. The transgenic lines generated will serve as important biological resources to examine this question in more detail.

## CHAPTER II

### THE HISTIDINE KINASE DOMAIN OF ETR1 IS REQUIRED FOR ETHYLENE SIGNALING IN *ARABIDOPSIS*

(This chapter is based in part on a manuscript submitted for publication: Xue-Chu Zhao, Xiang Qu, Dennis E. Mathews, and G. Eric Schaller. Effect of Ethylene Pathway Mutations upon Expression of the Ethylene Receptor ETR1 from *Arabidopsis*)

#### ABSTRACT

In *Arabidopsis*, the gaseous plant hormone ethylene is perceived by a receptor family consisting of five members, one of these being ETR1. The amino-terminal half of ETR1 functions as a signal input domain. The carboxy-terminal region of ETR1, consisting of a histidine kinase domain and a putative receiver domain, is likely to function in signal output. The role of the proposed signal output region in ethylene signaling was examined *in planta*. For this purpose, the ability of mutant versions of ETR1 to rescue the constitutive response phenotype of the *etr1-6;etr2-3;ein4-4* triple loss-of-function mutant line was examined. A truncated version of ETR1 that lacks both the histidine kinase domain and the receiver domain failed to rescue the triple response phenotype. A truncated ETR1 receptor that lacks only the receiver domain restored normal growth to the triple mutant in air, but the transgenic seedlings displayed hypersensitivity to ethylene. A mutation that eliminated histidine kinase activity had a modest effect upon the ability of the receptor to repress ethylene responses in air. These results demonstrate that the histidine kinase domain plays a role in the repression of

ethylene responses. The potential roles of the receiver domain and histidine kinase activity in ethylene signaling are discussed.

## INTRODUCTION

The simple bi-carbon gaseous hormone ethylene plays important roles throughout the plant life cycle (Abeles et al., 1992). Plants have developed a complex and sophisticated signal perception and transduction system to control ethylene responses. In *Arabidopsis*, ethylene is perceived by a receptor family consisting of five members: ETR1, ETR2, ERS1, ERS2, and EIN4 (Schaller, 2000; Chang and Stadler, 2001). As the first identified ethylene receptor, ETR1 has been characterized in the most detail (Chang et al., 1993; Schaller and Bleecker, 1995).

The ethylene receptor ETR1 has a modular structure. The amino-terminal portion of ETR1 contains three hydrophobic regions and functions as a signal input domain (Schaller and Bleecker, 1995). The transmembrane segments not only confer ethylene binding ability but also localize the receptor to the endoplasmic reticulum (ER) (Schaller and Bleecker, 1995; Chen et al., 2002). Perception of ethylene by ETR1 also requires a copper cofactor (Rodriguez et al., 1999). Two cysteine residues, located near the N-terminus, form disulfide linkages that link two monomers of ETR1 together to make a receptor dimer in the membrane (Schaller et al., 1995).

The carboxy-terminal region of ETR1 is likely to be involved in signal output. It consists of a histidine kinase domain and a receiver domain (Chang et al., 1993). These are evolutionarily related to signal transducing elements originally identified in the two-component systems of bacteria, which have also been demonstrated to exist in eukaryotic species of plants and fungi (Parkinson, 1993; Schaller, 2000). Histidine kinase activity of

ETR1 has been demonstrated (Gamble et al., 1998), but the role of histidine kinase activity in ethylene signal transduction is still unknown (Gamble et al., 2002; Wang et al., 2003). It has also been demonstrated that the histidine kinase and receiver domains of ETR1 can interact with the Raf-like kinase CTR1 (Clark et al., 1998; Gao et al., 2003). CTR1 is a negative regulator acting downstream of the ethylene receptors in the ethylene signaling pathway (Kieber et al., 1993). These results suggest that, as part of an ethylene receptor signaling complex, activity of CTR1 could be modulated enzymatically or allosterically by ETR1.

Despite similarity in protein structure among all five members of the *Arabidopsis* ethylene receptor family, each ethylene receptor has distinctive features. Only two receptors (ETR1 and ERS1) contain conserved and functional histidine kinase domains (subfamily 1) (Chang et al., 1993; Hua et al., 1995); ETR2, ERS2, and EIN4 each possess diverged domains lacking essential motifs required for histidine kinase activity (subfamily 2) (Hua et al., 1998; Sakai et al., 1998). In addition, both ERS1 and ERS2 lack a receiver domain at the carboxy-terminus (Hua et al., 1995; Hua et al., 1998). These structural differences suggest that individual receptors could function differently in ethylene signaling. To dissect the role(s) of the ethylene receptors, loss-of-function mutant alleles of *ETR1*, *ETR2*, *ERS2* and *EIN4* have been isolated (Hua and Meyerowitz, 1998). Due to functional overlap, single loss-of-function mutations have little effect upon plant growth in response to ethylene. However, higher order mutant combinations, such as triple or quadruple mutants, display constitutive ethylene responses (Hua and Meyerowitz, 1998). These results indicate that ethylene receptors act as negative regulators in ethylene signal transduction.

The *etr1;etr2;ein4* triple loss-of-function mutant displays a constitutive ethylene response growth phenotype (Hua and Meyerowitz, 1998), because the two remaining receptor members in this mutant background (ERS1 and ERS2) are insufficient to repress ethylene responses in the absence of ethylene. It should also be noted that neither ERS1 nor ERS2 contains a receiver domain. In this study, I used the *etr1;etr2;ein4* triple mutant as a genetic background to examine the ability of various ETR1 mutants to rescue the triple mutant phenotype. I focused on the role that the hypothesized signal output region of ETR1 plays in regulating ethylene signaling. My results confirm a role for the histidine kinase domain in ethylene signaling and lend insight into how the ethylene signal is transduced from ethylene receptors to downstream signaling components.

## MATERIALS AND METHODS

### *Arabidopsis* Strains and Growth Conditions

All *Arabidopsis* strains used in this study, including WT (wild-type), *etr1-5*, *etr1-6*, *etr1-7*, *etr1-8*, and *etr1;etr2;ein4*, are of ecotype *Columbia* (Hua and Meyerowitz, 1998). For etiolated seedlings, seeds were grown on Petri plates with one-half-strength Murashige and Skoog basal media with Gamborg's vitamins (pH 5.75; Sigma, St. Louis) and 0.8% (w/v) agar. Seeds were sterilized by a 1-minute wash with 70% (v/v) ethanol, followed by a 10-minute incubation with 20% (v/v) Clorox bleach containing 1% (v/v) Triton X-100 (Sigma, St. Louis). After a 2-day cold treatment at 4°C, seeds were exposed to light for 10 hours and then incubated in the dark at 22°C. For green plants, seeds were grown on soil with 16-hour light/8-hour dark fluorescent illumination at 22°C.

## **Constructs and Plant Transformation**

All *ETR1* constructs were driven by their native genomic promoter. The *ETR1-FL* construct represents a genomic copy of wild-type *ETR1* (Gamble et al., 2002); *ETR1(G2)* is full-length genomic sequence containing a mutated G2 box (G545A and G547A) (Gamble et al., 2002), which results in abolishment of the histidine kinase activity (Gamble et al., 2002). *ETR1(1-349)* is a genomic fragment of *ETR1* that lacks the sequence coding for the histidine kinase domain and the downstream receiver domain (Gamble et al., 2002). *ETR1(1-603)*, which encodes a truncated receptor lacking the receiver domain alone, was generated by PCR from a 7.3-kb genomic fragment (Chang et al., 1993) containing promoter and coding region of *ETR1* using the forward primer 5'-ATGCTCATGATCTGTCTACGCTACG-3' and the reverse primer 5'-GTCGACTTATCCAGTGAAATTTGAATGTC-3'. The PCR product was then ligated into the *Bam*HI and *Sal*I sites of the binary vector pCAMBIA1380 as previously described (Gamble et al., 2002). All constructs were transformed into the *etr1-6;etr2-3;ein4-4* triple loss-of-function mutant background. For this purpose, the floral-dip method for *Agrobacterium*-mediated transformation of *Arabidopsis* was used (Clough and Bent, 1998). Independent homozygous lines for each transformation were obtained based on segregation of the acquired antibiotic resistance: kanamycin for the *ETR1(G2)* construct and hygromycin for the other constructs.

## **Seedling Growth Response Assays**

To examine the triple response of seedlings to ethylene (Chen and Bleecker, 1995; Hall et al., 1999), seeds were grown on Petri plates containing medium to which 5  $\mu$ M of

aminoethylvinyl-glycine (AVG) was added to inhibit endogenous ethylene biosynthesis by the seedlings. Plates were placed in 4.5-liter air-tight sealed containers in the presence of ethylene at the desired concentration. All containers were kept in the dark at 22°C. To examine the growth of seedlings in the absence of ethylene, hydrocarbon-free air was passed through the chambers to remove trace amounts of ethylene synthesized by the seedlings. Seedlings were examined after 4 d, time 0 corresponding to when the plates were removed from 4°C and brought to 22°C. To measure hypocotyl length, seedlings were grown on vertically oriented square plates. Seedlings were scanned by use of Photoshop (version 5.5, Adobe Systems, Mountain View, CA) and an Epson 1240U scanner, and hypocotyl length was then measured using NIH Image (version 1.6, National Institute of Health, Bethesda, MD).

### **Antibody Affinity Purification**

To eliminate cross reactions with non-specific *Arabidopsis* polypeptides that possess similar molecular weights to the reduced forms of full-length and truncated ETR1 receptors, the polyclonal  $\alpha$ ETR1(165-400) serum (Schaller et al., 1995) was affinity purified. First, about 0.5 mL of serum was passed through a negative-selection column, containing 0.5 mL of GST-linked Affigel-10 beads. Then the depleted serum was applied to a positive-selection column of Affigel-10 beads cross-linked to GST-ETR1(165-400). For all washes, pre-chilled PBS buffer (at 4°C) was used. Antibodies were eluted with 100 mM glycine (pH 2.5), neutralized with 1 M Tris (pH 8.0), and dialyzed against PBS buffer. Cross-linking to Affigel was performed according to the manufacturer (Bio-Rad



Laboratories, Hercules, CA). The pGEX vector was used to produce the GST protein, and the GST-ETR1(165-400) affinity tag was obtained from the pGEX-ETR1(165-400).

### **Membrane Protein Isolation and Western Blot Analysis**

To isolate membrane proteins, etiolated seedlings were homogenized in extraction buffer (50 mM Tris, pH 8.5, 150 mM NaCl, 10 mM EDTA, 20% [v/v] glycerol). Protease inhibitors [1 mM phenylmethylsulfonyl fluoride (PMSF), 1  $\mu$ g/mL pepstatin, 10  $\mu$ g/mL leupeptin, and 10  $\mu$ g/mL aprotinin] were included to prevent protein degradation. The homogenate was first filtered through Miracloth (Calbiochem-Novobiochem, San Diego, CA), and then centrifuged at 8,000 g for 15 minutes. The supernatant was centrifuged at 100,000 g for 30 min. The membrane pellet was then resuspended in resuspension buffer (10 mM Tris, pH 7.5, 150 mM NaCl, 1 mM EDTA, and 10% [v/v] glycerol) with protease inhibitors. Procedures described above were all done at 4°C. The BCA protein assay was used to determine protein concentration according to the manufacturer's instructions (Pierce, Woburn, MA). Bovine serum albumin was used to generate a standard curve of protein concentration.

Proteins were resuspended in SDS-PAGE loading buffer with or without 100 mM DTT (Schaller, et al., 1995). The reductant DTT was not included in the loading buffer when it was desired to preserve the disulfide-linked dimer of ETR1. Membrane proteins were incubated at 50°C for 1 h and then fractionated by SDS-PAGE using either 8% or 10% (w/v) polyacrylamide gels (Laemmli, 1970). After electrophoresis, proteins were electro-transferred and immobilized on Immobilon nylon membrane (Millipore, Bedford, MA). Two antibodies were used to visualize ETR1. The  $\alpha$ -ETR1(401-738) antibody was

generated against the carboxy-terminal half of ETR1 from amino acids 401 to 738 (Schaller et al., 1995), which includes most of the histidine kinase domain and the entire receiver domain. The  $\alpha$ ETR1(165-400) antibody was generated against amino acids 165 through 400 of ETR1 (Schaller et al., 1995), and was used to identify truncated ETR1 receptors lacking the histidine kinase domain. The  $\alpha$ ETR1(165-400) antibody recognizes the dimeric form of ETR1 preferentially over the monomeric form (Schaller, et al., 1995). All protein samples in western blots examined using the  $\alpha$ ETR1(165-400) antibody were resuspended in SDS-PAGE loading buffer without DTT unless otherwise mentioned. Immunodecorated ETR1 was visualized using an enhanced chemoluminescence detection system according to the manufacturer (Pierce Chemical, Rockford, IL). Densitometric analysis of immunodecorated bands was performed using NIH Image (version 1.6, National Institute of Health, Bethesda, MD) after scanning the exposed film using Photoshop (version 5.5, Adobe Systems, Mountain View, CA) and an Epson 1240U scanner. The relative expression level for ETR1 was quantified by comparison to a dilution series of ETR1.

### **mRNA Isolation and Northern Blot Analysis**

Total RNA was isolated from 4-day-old *Arabidopsis* etiolated seedlings according to Carpenter and Simon, 1998. The mRNA was purified from total RNA using the PolyAtract mRNA isolation system (Promega, Madison, WI). For northern-blot analysis, mRNA was separated on 1% (w/v) agarose gels using the NorthernMax-Gly system (Ambion, Austin, TX). Separated RNAs were transferred to MagnaCharge nylon membrane by the capillary method (GE Osmonics, Minnetonka, MN) and fixed by UV-

cross linking using GS Gene Linker UV Chamber (Bio-Rad Laboratories). Single-stranded DNA antisense probes were made using primers designed to anneal at the 3' end of the selected genes (5'-ATCCAAATGTTACCCTCCATCAGATTCAC-3'). For the PCR template, pBLUE-cETR1 was digested by *Dra*I. Radio-labeled probes were made and stripped off from membranes between hybridizations using the Strip-EZ PCR system from Ambion according to the manufacturer's manual. Radioactivity was imaged and quantified by phosphor imaging with a Molecular Imager FX (Bio-Rad Laboratories), using accompanying Quantity One software.

## RESULTS

### **Loss-of-function Mutations Eliminate Protein Expression of the Ethylene Receptor ETR1**

*etr1-5*, *etr1-6*, *etr1-7* and *etr1-8* are loss-of-function mutant alleles of *ETR1* (Hua and Meyerowitz, 1998). They were identified as intragenic suppressors by mutagenesis screens of the dominant ethylene-insensitive alleles *etr1-1* and *etr1-2* (Figure 8A). All these loss-of-function mutants contain point mutations predicted to result in premature truncations in different regions of the receptor, and mutant seedlings show similar ethylene responses compared to wild-type (Hua and Meyerowitz, 1998). The *etr1-5*, *etr1-7* and *etr1-8* mutations all introduce premature stop codons into the coding sequence. The *etr1-6* mutant contains a point mutation at the intron splice site and would also produce premature stop codons due to retention of that intron (Hua and Meyerowitz, 1998). To determine whether the loss-of-function arises from an absence of the receptor or from a truncated receptor incapable of signaling, expression of the receptor mutants was

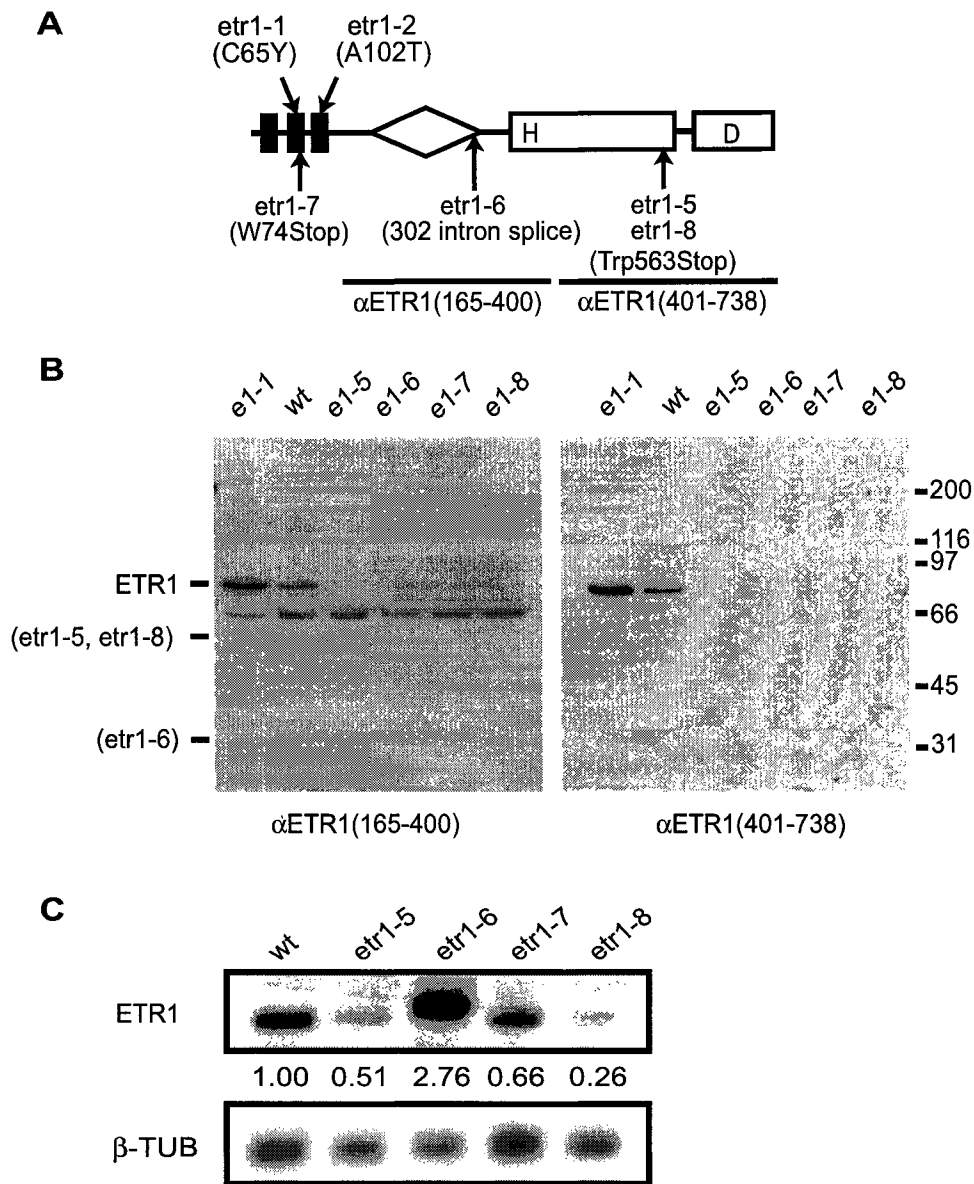

**Figure 8.** Effect of loss-of-function mutations in *ETR1* upon its expression (modified from Zhao et al., 2002). **A**, Positions of mutations in *ETR1*. The positions of ethylene-insensitive mutations are shown above the diagram of *ETR1*. The positions of intragenic suppressors of these mutations that result in loss of function are shown below the diagram of *ETR1*. Positions of regions used to generate the  $\alpha$ ETR1(165-400) and  $\alpha$ ETR1(401-738) antibodies are also indicated. **B**, Immunoblot analysis of *ETR1* in different loss-of-function backgrounds. Membrane fractions (10  $\mu$ g) from etiolated *Arabidopsis* seedlings were analyzed by immunoblot using the  $\alpha$ ETR1(165-400) and  $\alpha$ ETR1(401-738) antibodies. The migration position of *ETR1* and predicted migration positions of the *etr1-5*, *etr1-6*, and *etr1-8* truncated receptors are indicated on the left. Migration positions of molecular mass markers are indicated on the right in kilodaltons. **C**, Transcript levels of *ETR1* in different loss-of-function backgrounds. Blots of mRNA were probed with an *ETR1* probe and a  $\beta$ -tubulin gene probe as an internal control. The numbers represent the expression level of the ethylene receptor gene after normalization for the level of  $\beta$ -tubulin gene expression.

analyzed by western blot (Fig. 8B). Two antibodies,  $\alpha$ ETR1(165-400) and  $\alpha$ ETR1(401-738), were used to target different regions of the receptor. A truncated protein for *etr1-5* and *etr1-8* should be detectable by both antibodies if present. On the other hand, neither antibody should be able to recognize the *etr1-6* and *etr1-7* truncations based on our previous observations. No full-length or truncated proteins were detected for any of these loss-of-function mutants (Figure 8B). Note that the  $\alpha$ ETR1(165-400) antibody recognizes an *Arabidopsis* polypeptide of 68 kD, which is not derived from ETR1.

To determine whether the lack of *etr1-5* and *etr1-8* mutant proteins is due to instability of the truncated protein or of the mRNA, northern-blot analysis was performed. mRNAs were detected for all four loss-of-function mutants (Figure 8C). The mRNA for *etr1-6* has a slightly higher molecular mass than the other messages, as expected because of the unspliced intron. Compared with wild-type, the mRNA levels of *etr1-5* and *etr1-8* were reduced approximately 2- or 4-fold, respectively, whereas the mRNA level of *etr1-7* was almost halved. In contrast, the level of the *etr1-6* mRNA was increased more than 3-fold compared to wild-type. The reduction in message levels of *etr1-5* and *etr1-8* was significant but not sufficient to explain the lack of detectable protein, indicating that posttranscriptional mechanisms may also play a role in reducing the levels of the truncated proteins.

### **Addition of the Full-length ETR1 Receptor Rescues the *etr1;etr2;ein4* Triple Loss-of-function Mutant Phenotype**

The experiments described above indicated that I could not use the *etr1* loss-of-function mutants to directly assess the role of the proposed signal output domain. I

therefore took a different approach using the *etr1-6;etr2-3;ein4-4* triple loss-of-function mutant line as a genetic background to characterize signal output by ETR1. In this study, to assess ethylene responses in seedlings, I took advantage of the ethylene-induced "triple response". Ethylene or its biosynthetic precursor ACC has a profound impact upon the growth of dark-grown (etiolated) seedlings (Guzman and Ecker, 1990). It inhibits hypocotyl and root elongation, induces swelling of the hypocotyl (stem), and tightens the closure of the apical hook. The *etr1-6;etr2-3;ein4-4* triple mutant exhibits a partial triple-response phenotype, including a stunted hypocotyl, even in the absence of ethylene (Figure 9A).

I first determined if wild-type *ETR1* could rescue the mutant phenotype. For this purpose, a 7.3-kb genomic fragment containing promoter and coding regions of *ETR1* was introduced into the triple mutant background. Three independent homozygous lines were isolated and characterized further. Initial analysis indicated that instead of displaying a constitutive ethylene-response phenotype, the transformed plants grew similarly to wild-type seedlings in air (Figure 9A). Expression of the full-length *ETR1* transgene (*ETR1-FL*) in these lines was confirmed by western-blot analysis, using membrane proteins isolated from 4-d old etiolated seedlings. Protein expression levels of *ETR1-FL* in these lines were similar to each other, and they were all higher than that of endogenous ETR1 in wild-type seedlings (Figure 9B).

A quantitative analysis of ethylene responsiveness was performed on the transgenic lines. Etiolated seedlings were grown in air and in ethylene at concentrations ranging from 0 to 1000  $\mu\text{L L}^{-1}$  for 4 days, and the hypocotyl length of the seedlings was then measured. As shown in Figure 9C, all three transgenic lines exhibited a similar

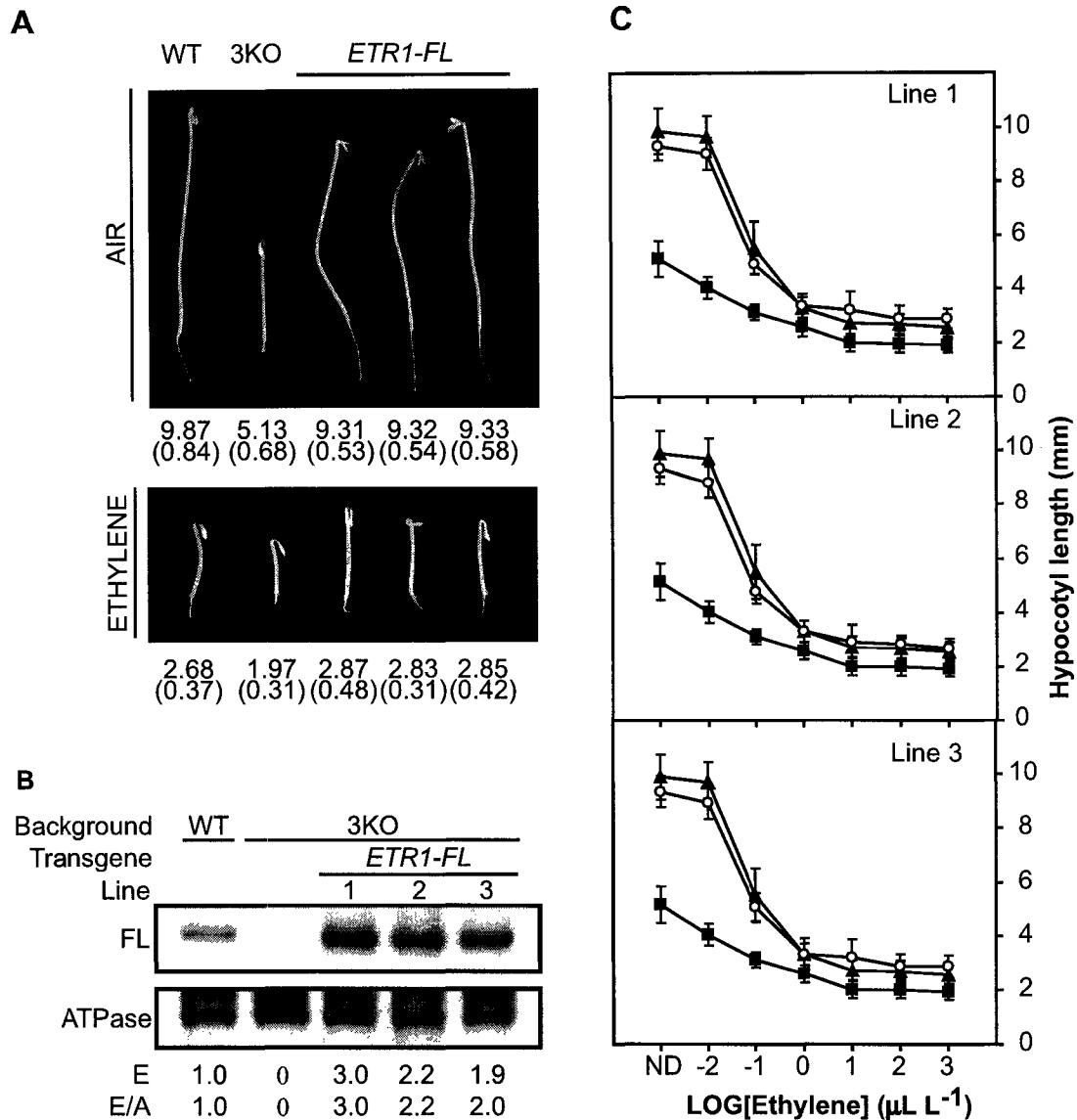

**Figure 9.** Effect of the *ETR1-FL* receptor upon the triple response of the *etr1-6;etr2-3;ein4-4* dark-grown seedlings. **A**, Etiolated seedling growth response of wild type (WT), the *etr1;etr2;ein4* triple loss-of-function mutant (3KO), and three independent transgenic lines for *ETR1-FL*. Phenotypes of 4-d-old seedlings grown in the absence of ethylene (AIR) and in the presence of  $100 \mu\text{L L}^{-1}$  ethylene (ETHYLENE) are shown. The mean hypocotyl length is given in millimeters based on measurement of at least 25 seedlings with the standard deviation in parentheses. **B**, Protein expression of *ETR1-FL* by western-blot analysis. The level of immunodetectable full-length receptor (FL) for each of the plant line was quantified densitometrically (E) and also normalized against the ATPase control (E/A). **C**, Ethylene dose response curves of hypocotyl growth from the three independent transgenic lines for *ETR1-FL* (open circles) are shown. For comparison, ethylene dose response curves are shown for control wild-type (black triangle) and 3KO (black square) hypocotyls. Values represent the means  $\pm$  SD of at least 25 measurements. ND, No detectable ethylene.

responsiveness to ethylene as the wild-type seedlings, indicating that addition of the full-length ETR1 receptor fully restored ethylene responsiveness to the *etr1-6;etr2-3;ein4-4* mutant line.

These data indicated that the *etr1;etr2;ein4* line can be used as a testing platform to directly assay which part of the ethylene receptor ETR1 is crucial for signal output. In the subsequent experiments, I describe data obtained by adding mutant versions of the ETR1 receptor into this background and analyzing their ability to rescue the triple mutant phenotype (Figure 10A).

### **The Carboxy-Terminal Half of the Ethylene Receptor ETR1 is Required for**

#### **Ethylene Signaling**

The proposed signal output region, including histidine kinase domain and receiver domain, is located in the carboxyl-terminal half of the ETR1 receptor (Figure 5). To address whether the proposed signal output region of ETR1 is indeed involved in ethylene signaling, a truncated version of the receptor, ETR1(1-349), was generated (Gamble et al., 2002). *ETR1(1-349)* is a genomic fragment of *ETR1*, driven by the native promoter, that encodes the amino-terminal half of the receptor, and lacks sequences encoding the histidine kinase and receiver domains (Figure 10B).

As shown in Figure 11A, in contrast to *ETR1-FL*, homozygous transgenic lines carrying *ETR1(1-349)* in the *etr1;etr2;ein4* triple mutant background still exhibited an ethylene response growth phenotype in the absence of ethylene. To determine whether the failure to rescue the triple mutant phenotype arises from an absence of the ETR1(1-349) protein or from a truncated receptor incapable of signaling, membrane proteins were



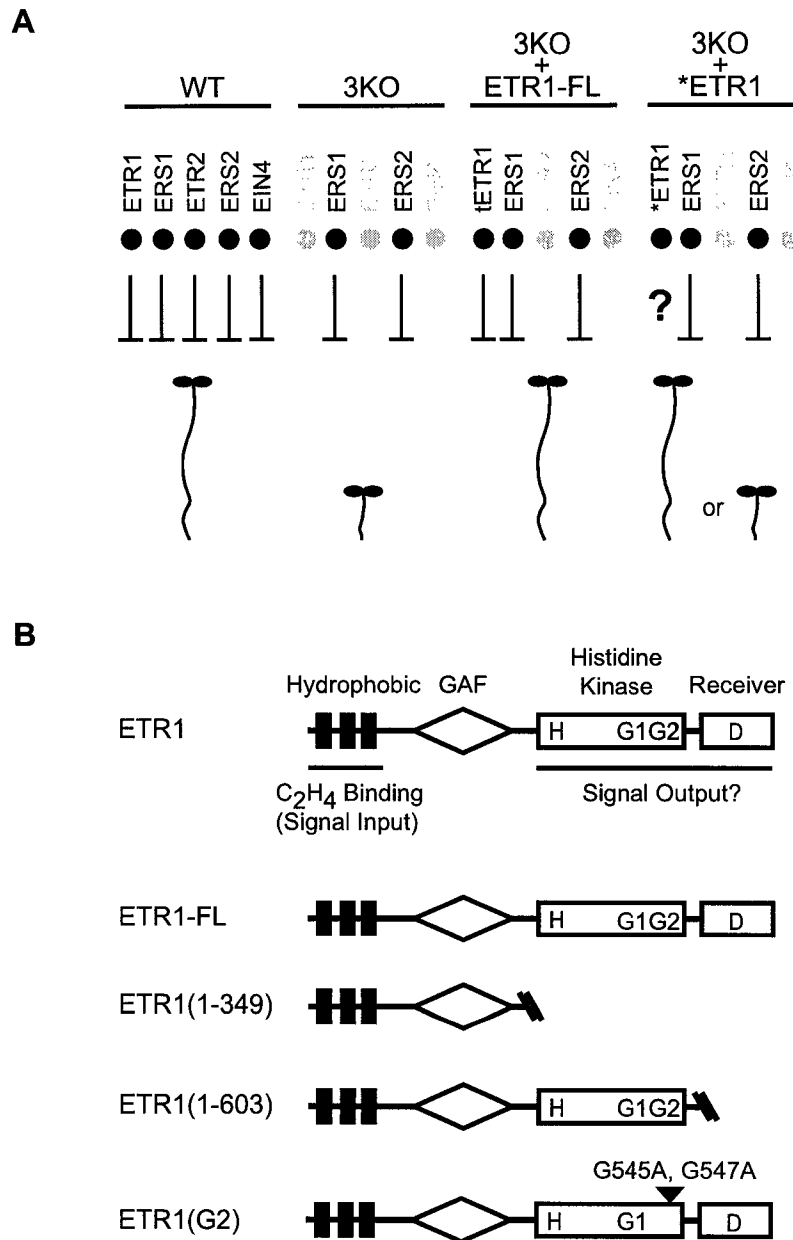

**Figure 10.** Experimental strategy and constructs used for experimental analysis. **A**, All the five receptors actively repress ethylene responses in wild-type plants. ERS1 and ERS2 can not efficiently repress ethylene responses in the *etr1;etr2;ein4* triple knockout background (3KO). As a result, etiolated seedlings show a constitutive ethylene-responsive phenotype. Addition of the full-length ETR1 (ETR1-FL) rescues the triple mutant phenotype. \*ETR1 represents different mutant versions of ETR1. **B**, Domains of the full-length ETR1 protein and versions of ETR1 expressed as transgene in *Arabidopsis*. H indicates His-353 and D indicates Asp-659, the putative phosphorylation sites. G1 and G2 indicate positions of the G1 and G2 boxes within the kinase domain. The proposed signal output region consists of the histidine kinase domain and the receiver domain. For the site-directed mutation, the G2-box mutation refers to G545A, G547A.

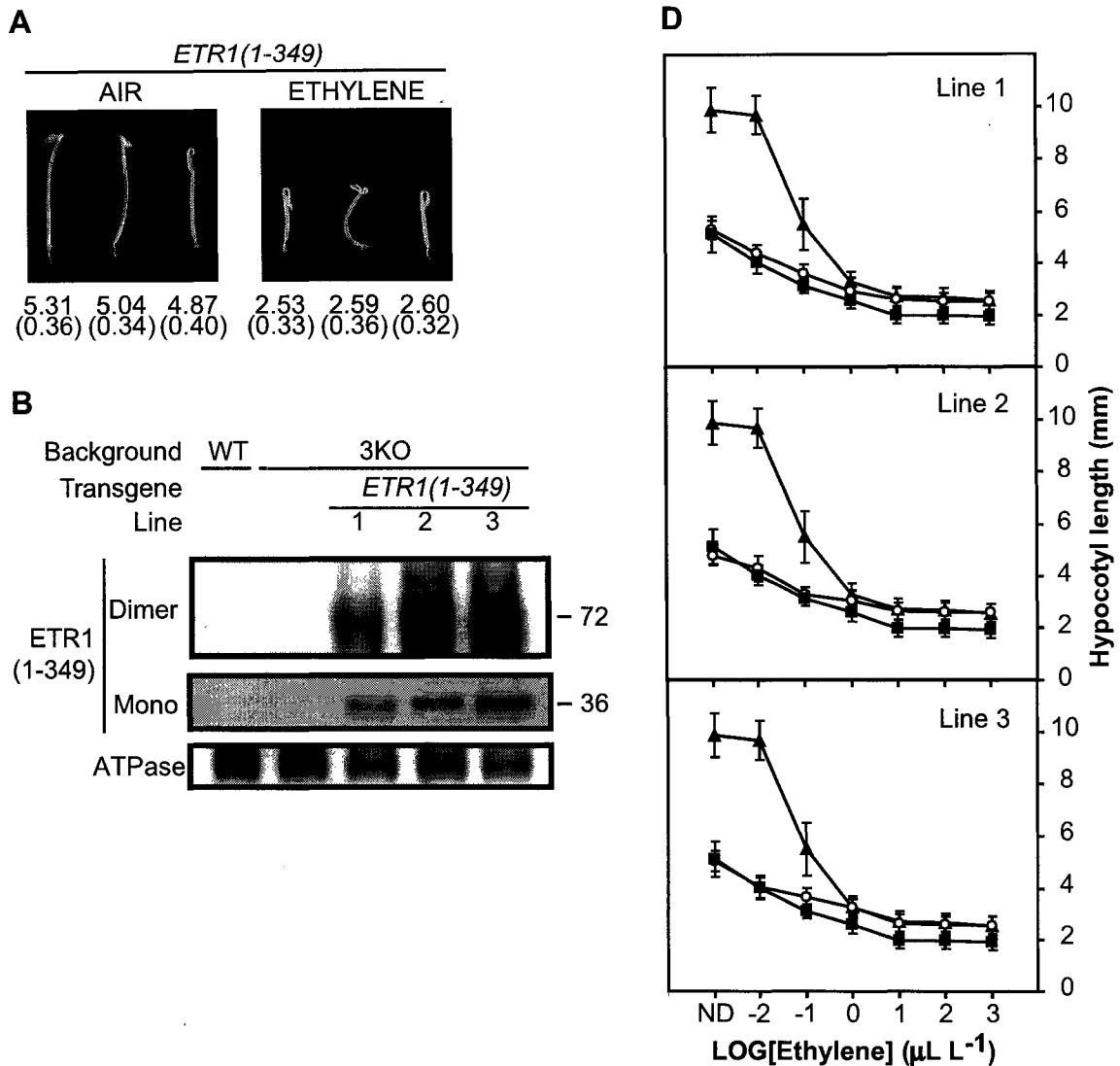

**Figure 11.** Effect of the *ETR1(1-349)* mutant receptor upon the triple response. **A**, The *ETR1(1-349)* transgene was transformed into the *etr1;etr2;ein4* triple loss-of-function line (3KO). Representative seedlings from three independent transgenic line for *ETR1(1-349)* are shown after 4 d growth in the absence of ethylene (AIR) and in the presence of  $100 \mu\text{L L}^{-1}$  ethylene (ETHYLENE). The mean hypocotyl length is given in millimeters based on measurement of at least 25 seedlings with the standard deviation in parentheses. **B**, Protein expression of the transgene. The full-length receptor (FL) was detected by the  $\alpha\text{ETR1}(401-738)$  antibody. The truncated receptor (1-349) was detected as a dimer by the  $\alpha\text{ETR1}(165-400)$  antibody. **C**, Quantitative assay of expression of *ETR1(1-349)* by immunoblot with the affinity-purified  $\alpha\text{ETR1}(165-400)$  antibody. In the presence of the reducing reagent DTT, the full-length receptor (FL) migrates as a 77-kD monomer and the truncated receptor (1-349) migrates as a 36-kD monomer. Expression levels are given based directly upon that determined with the  $\alpha\text{ETR}(165-400)$  antibody (E) and normalized against the ATPase levels (E/A). **D**, Ethylene dose response curves of hypocotyl growth from three independent transgenic lines for *ETR1(1-349)* (open circles) are compared to that of the 3KO (black square) and WT (black triangle) controls. Values represent the means  $\pm$  SD of at least 25 measurements. ND, No detectable ethylene.

isolated and protein expression of the truncated *ETR1(1-349)* transgene confirmed by immunoblot analysis (Figure 11B). ETR1(1-349) was detected by the  $\alpha$ ETR1(165-400) antibody at the expected molecular weight of 36 kD for the monomer, and at 68 kD for the dimer. Although ETR1(1-349) could be readily detected, I could not detect wild-type ETR1 in the control, indicating that ETR1(1-349) is expressed significantly above wild-type levels. Thus the inability of the transgene to rescue the triple mutant is due to an inability of the truncated receptor to signal properly. A dose response curve confirmed the similarity of the transgenic lines to the triple mutant control in air and at low ethylene concentrations (Figure 11C). However, in the presence of high levels of ethylene (from 1 to 1000  $\mu\text{L L}^{-1}$ ), a difference in hypocotyl length between the transgenic lines and the triple mutant was observed (Figure 11C).

Based on these results, I concluded that the truncated ETR1(1-349) receptor was not capable of rescuing the constitutive ethylene-response phenotype of the *etr1;etr2;ein4* triple loss-of-function mutant, indicating that the carboxy-terminal half of the receptor, containing histidine kinase and receiver domains, is important for ethylene signaling in *Arabidopsis*.

### **Effect of the Receiver Domain of ETR1 on Rescue of the *etr1;etr2;ein4* Triple**

#### **Mutant Phenotype**

ETR1, ETR2, and EIN4 are the only members in the *Arabidopsis* ethylene receptor family that possess a receiver domain and, thus, there are no ethylene receptors with receiver domains in the *etr1;etr2;ein4* triple mutant. To further assess the role of the carboxy-terminal half of ETR1 in ethylene responses, another truncated version of the

receptor, named *ETR1(1-603)*, was generated and transformed into the *etr1;etr2;ein4* background. *ETR1(1-603)* is a genomic fragment of *ETR1*, driven by its native promoter, that encodes a truncated ETR1 receptor lacking the receiver domain (Figure 10B).

Homozygous lines carrying the *ETR1(1-603)* transgene in the *etr1-6;etr2-3;ein4-4* triple loss-of-function mutant background were isolated and characterized. As shown in Figure 12A, all three transgenic lines display a wild-type-like growth phenotype in air. The presence of the truncated ETR1(1-603) protein in the triple mutant transgenic lines was confirmed by immunoblotting with both  $\alpha$ ETR1(165-400) and  $\alpha$ ETR1(401-738) antibody (Figure 12B). Thus, the receiver domain is not required for ETR1 to repress ethylene responses. Despite their normal seedling growth response in air, all of the transgenic lines exhibited hypersensitivity to ethylene (Figure 12C). For example, in the presence of  $0.01 \mu\text{L L}^{-1}$  ethylene, hypocotyl length of the *ETR1(1-603)* transgenic seedlings decreased from 9.8 (when grown in the absence of ethylene) to 6.5 mm, whereas wild-type seedlings showed little change in height.

### **Effect of Histidine Kinase Activity of ETR1 on Rescue of the *etr1;etr2;ein4* Triple Mutant Phenotype**

The previous experiments demonstrated that the histidine kinase domain of the ethylene receptor ETR1 is required for rescue of the triple mutant phenotype. To determine if histidine kinase activity of ETR1 is required for rescue, I used a site-directed mutant of ETR1 containing a lesion in the G2 box. Mutations in the G2 box (G545A and G547A) affect the ability of ATP to bind to the kinase, and thus abolish histidine kinase activity of ETR1 (Bilwes et al., 1999; Gamble et al., 2002). *ETR1(G2)* was transformed

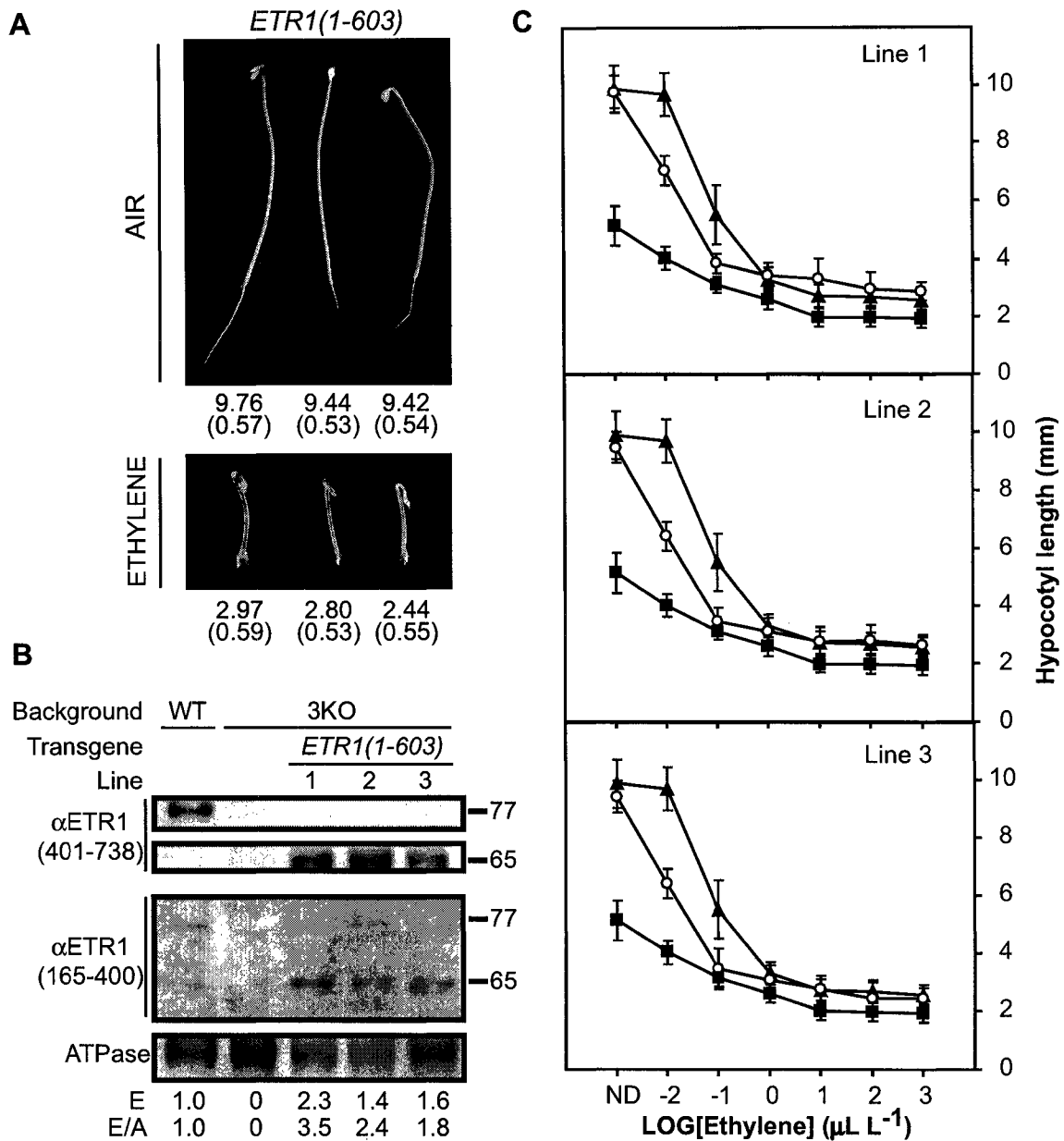

**Figure 12.** Effect of the *ETR1(1-603)* mutant receptor upon the triple response. The *ETR1(1-603)* transgene was transformed into the *etr1;etr2;ein4* triple loss-of-function line (3KO). **A**, Representative seedlings from three independent lines for the *ETR1(1-603)* transgene are shown after 4-d growth in the absence of ethylene (AIR) and in the presence of  $100 \mu\text{L L}^{-1}$  ethylene (ETHYLENE). Mean hypocotyl lengths are given in millimeters with SD in parentheses. **B**, Protein expression of the transgene was determined by immunoblot analysis with both  $\alpha\text{ETR1}(165-400)$  and  $\alpha\text{ETR1}(401-738)$  antibodies. In the presence of the reducing reagent DTT, the full-length receptor migrates as a 77-kD monomer and the truncated *ETR1(1-603)* migrates as a 65-kD monomer. Expression levels are given based directly upon that detected by the  $\alpha\text{ETR1}(165-400)$  antibody (E) and normalized against the ATPase levels (E/A). **C**, Ethylene dose response curves of hypocotyl growth from three independent lines for *ETR1(1-603)* (open circle) are compared to that of the 3KO (black square) and WT (black triangle) controls. Values represent the means  $\pm$  SD of at least 25 measurements. ND, No detectable ethylene.

into the *etr1-6;etr2-3;ein4-4* triple loss-of-function mutant background to examine whether, without its kinase activity, the full-length receptor could still rescue the constitutive ethylene-response phenotype of the mutant line (Figure 10B).

As shown in Figure 13A, seedlings from all three homozygous transgenic lines containing the *ETR1(G2)* transgene displayed normal growth in air with straightened apical hooks, and elongated hypocotyls and roots. However, hypocotyl length of the transgenic seedlings was slightly shorter than that of the wild-type controls in air. Differences in hypocotyl length between the *ETR1(G2)* transgenic lines and the wild-type control were significant ( $\rho \leq 0.05$ ). Western-blot analysis confirmed that the transgene was expressed in the transgenic triple loss-of-function lines and that the protein levels of *ETR1(G2)* were similar to or greater than that of the wild-type control (Figure 13B). Thus, inefficiency in completely restoring hypocotyl elongation by the mutant *ETR1(G2)* receptor was not due to decreased receptor expression. To further assess the effect of the *ETR1(G2)* transgene in conferring ethylene responses, a quantitative analysis of the ethylene dose response was performed. In comparison with wild-type, transgenic seedlings displayed slightly increased ethylene sensitivity (Figure 13C).

## DISCUSSION

The function of ethylene receptors in ethylene signal transduction can be considered to contain two major aspects according to the prevailing receptor-CTR1 signaling model based on genetic studies in *Arabidopsis* (Bleecker and Kende, 2000; Schaller and Kieber, 2002): (1) a role in the repression of ethylene responses in the absence of ethylene, and (2) a role in the establishment of ethylene responses in the

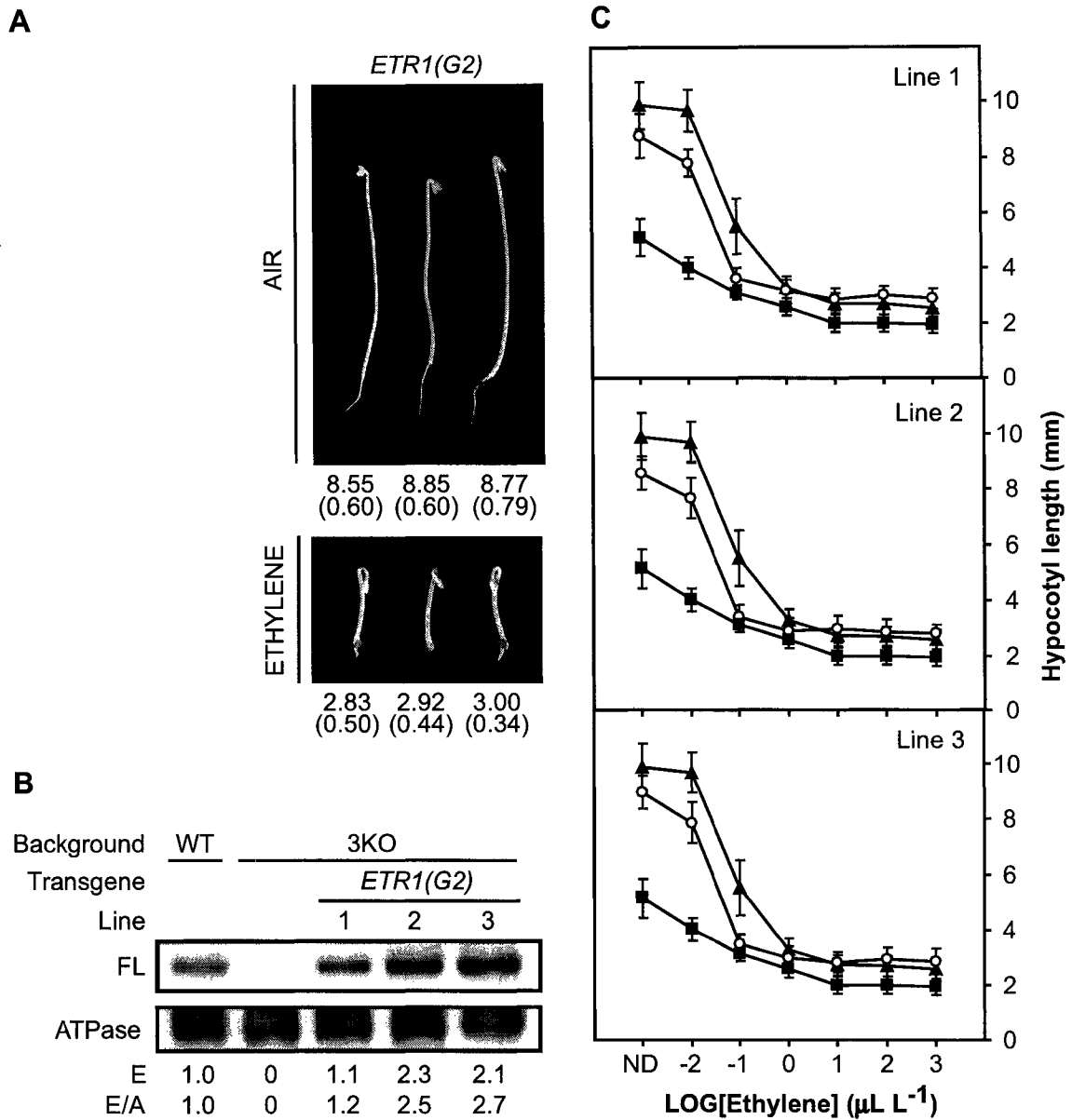

**Figure 13.** Effect of the *ETR1(G2)* mutant receptor upon the triple response. The *ETR1(G2)* transgene was transformed into the *etr1;etr2;ein4* triple loss-of-function line (3KO). **A**, Representative etiolated seedling from three independent lines for *ETR1(G2)* are shown after 4 d growth in the absence of ethylene (AIR) and in the presence of  $100 \mu\text{L L}^{-1}$  ethylene (ETHYLENE). **B**, Protein expression of *ETR1(G2)* by western-blot analysis. The level of immunodetectable full-length receptor (FL) for each of the plant line was quantified densitometrically (E) and also normalized against the ATPase control (E/A). **C**, Ethylene dose response curves of hypocotyl growth from three independent transgenic lines for *ETR1(G2)* (open circles) are shown. For comparison, ethylene dose response curves are shown for control wild-type (black triangle) and 3KO (black square) hypocotyls. Values represent the means  $\pm$  SD of at least 25 measurements. ND, No detectable ethylene.

presence of ethylene. Both *in vitro* and *in vivo* evidence supports that all five ethylene receptors interact with CTR1 and form a stable signaling complex at the endoplasmic reticulum (ER) membrane to regulate the ethylene pathway (Clark et al., 1998; Cancel and Larsen, 2002; Gao et al., 2003). CTR1, a downstream Raf-like protein kinase, is a negative regulator in ethylene signaling and loss-of-function mutations in *CTR1* result in constitutive ethylene responses (Kieber et al., 1993; Huang et al., 2003). Higher order ethylene receptor loss-of-function mutations result in a constitutive ethylene response phenotype and a loss of CTR1 from the ER membrane (Hua and Meyerowitz, 1998; Gao et al., 2003). Thus, the role of ethylene receptors in air may be achieved by maintaining both the activity and the correct location for action of CTR1 via association with CTR1 within the same protein complex.

The loss-of-function mutants *etr1-5*, *etr1-6*, *etr1-7*, and *etr1-8* were isolated as intragenic suppressors of the ethylene-insensitive mutant alleles of *ETR1* (Hua and Meyerowitz, 1998). These mutations were predicted to result in truncated receptors due to premature termination during translation. However, our previous study indicated that a truncated *etr1-1* receptor containing the first 349 amino acids of the full-length protein could still confer ethylene insensitivity (Gamble et al., 2002). This raises the question as to why no ethylene insensitivity is observed with the loss-of-function mutants, in particular with *etr1-5* and *etr1-8*, which are predicted to code for receptors containing 562 amino acids. My data indicate that the *etr1-5* and *etr1-8* loss-of-function mutants have reduced expression at both the transcriptional and posttranscriptional levels. Transcript, but no protein, was detected for each of the *ETR1* loss-of-function mutants. Examination of *etr1-5* and *etr1-8* indicated a reduction to 43% and 23%, respectively, of



wild-type mRNA levels. This reduction in expression could be because of mechanisms for mRNA surveillance such as nonsense-mediated decay whereby mRNAs containing premature stop codons are targeted for degradation (van Hoof and Green, 1996).

Although decreases in message levels of *etr1-5* and *etr1-8* were detected, these were not sufficient to explain the lack of detectable protein since the antibodies would still be able to detect the truncated protein at concentrations suggested by the decreased mRNA levels. Results from control western-blot analysis indicated that the  $\alpha$ ETR1(165-400) antibody could detect protein expressed at 10% wild-type levels; and that the  $\alpha$ ETR1(401-738) antibody could detect protein expressed at 5% wild-type levels (data not shown). Thus, the results obtained with the loss-of-function mutations suggest that premature termination of the protein may lead to an absence of receptor rather than a truncated receptor, presumably because of instability of the truncated protein. The genetic screen for intragenic suppressors may have favored the isolation of destabilizing mutations.

Analysis of the truncated ETR1(1-349) and ETR1(1-603) receptors in the *etr1;etr2;ein4* triple loss-of-function mutant background indicates that the histidine kinase domain is needed for the role of the receptor in repressing ethylene responses in air. The truncated ETR1(1-349) receptor lacking both histidine kinase and receiver domain failed to rescue the triple mutant phenotype, while a truncated ETR1 receptor only lacking the receiver domain is still able to fully restore normal growth of the triple mutant in air. This is consistent with a role for the histidine kinase domain in activating CTR1. Previous studies indicate that CTR1 can associate with the histidine kinase domain of ETR1 (Clark et al., 1998; Gao et al., 2003). Genetic studies indicate that the interaction between CTR1 and ethylene receptors is required for the ability of CTR1 to

repress ethylene responses. The *ctr1-8* mutant contains a missense mutation that prevents interaction with ethylene receptors, and the mutant seedlings display a constitutive ethylene response phenotype, thereby indicating that the ER membrane localization of CTR1 is essential for its role in repression of ethylene responses (Gao et al., 2003; Huang et al., 2003). My data suggest that the histidine kinase domain of ETR1 may help recruit CTR1 to its site of action. Although histidine kinase activity of ETR1 is not required for the interaction between ETR1 and CTR1 (Gao et al., 2003), it is still not clear whether the enzymatic activity of ETR1 is involved in regulation of the kinase activity of CTR1.

*etr1-1* is a dominant ethylene insensitive mutant allele of *ETR1* (Schaller and Bleecker, 1995; Rodriguez et al., 1999). Interestingly, our previous work has shown that a truncated version of *etr1-1* lacking the histidine kinase domain *etr1-1(1-349)* can still confer dominant ethylene insensitivity in both the wild-type and the *etr1-7* loss-of-function mutant background (Gamble et al., 2002). Thus, *etr1-1(1-349)* is still able to repress ethylene responses even though it lacks the carboxy-terminal half. We previously proposed two models that could account for this ability: (1) the *etr1-1(1-349)* receptor might be directly capable of signal output; or (2) alternatively, the truncated *etr1-1(1-349)* receptor might be incapable of signal output, but be able to “convert” other wild-type receptors to an ethylene-insensitive signaling state. My data here demonstrate that the N-terminal half of the receptor is not sufficient for repressing ethylene responses and the histidine kinase domain is essential for signal output. Thus, my data support the model in which the truncated *etr1-1(1-349)* confers ethylene insensitivity by associating with other receptors.

The truncated ETR1(1-603) receptor, which lacks the receiver domain, is able to repress ethylene responses in air. However, the transgenic seedlings display hypersensitivity to ethylene, suggesting an involvement of this domain in the establishment of ethylene responses. The receiver domain may act as a negative regulator to modulate how plants respond to the ethylene stimulus. For example, the receiver domain could be in a signaling inactive state in air, but switch to a signaling active state and repress ethylene responses in ethylene. Possible targets could be downstream negative regulators such as CTR1, other CTR1 like proteins, or AHPs (*Arabidopsis* histidine containing phosphotransfer proteins) (Hwang et al., 2002; Lohrmann and Harter, 2002; Huang et al., 2003). Activation of the receiver domain could potentially be elicited by conformational changes, resulting from binding of ethylene by the receptor, or by phosphorylation occurring at the aspartate residue within the receiver domain. Alternatively, since the receiver domain of ETR1 interacts with CTR1 (Clark et al., 1998), it is possible that the truncated ETR1(1-603) receptor is not as effective as the wild-type receptor at maintaining CTR1 in an active state. This could increase the sensitivity of the seedlings to ethylene, because CTR1 would not be as effective at repressing the ethylene responses.

The full-length kinase-inactive ETR1(G2) receptor is able to partially rescue the *etr1;etr2;ein4* triple loss-of-function mutant phenotype. Dose response curves indicate that transgenic seedlings are slightly shorter than wild-type in air and also have slightly increased sensitivity to ethylene. Thus ETR1(G2) is not as effective as the wild-type receptor in the repression of ethylene responses. Since ETR1 interacts directly with CTR1 (Clark et al., 1998; Gao et al., 2003), it is possible that the histidine kinase activity

of ETR1 may modulate CTR1 activity. Alternatively, the mutant phenotype of the transgenic seedlings could arise from a dependence of ETR1 on phosphorylation as part of a two-component signaling system involving a His-to-Asp phosphorelay mechanism (Urao et al., 2000; Hwang and Sheen, 2001; Sheen, 2002). It is also possible that the G2 mutation itself could affect the interaction between CTR1 and the receptor such that ETR1(G2) is less effective at activating CTR1. However, the G2 mutation does not affect the ability of ETR1 to interact with CTR1 (Gao et al., 2003), indicating that the effect of the G2 mutation is not due to reduced capacity to bind CTR1.

Although the ETR1(1-349) receptor seemed to have no effect upon growth of the triple mutant seedlings in the absence of ethylene, a difference in hypocotyl elongation between the transgenic seedlings and seedlings from the mutant background was observed in the presence of ethylene. It has been previously reported that, besides a shift in ethylene sensitivity, the *etr1* loss-of-function mutations also lead to enhanced responsiveness to ethylene: mutant seedlings display an exaggerated reduction in hypocotyl elongation in comparison with wild-type (Cancel and Larsen, 2002). This *etr1* loss-of-function mutant effect upon hypocotyl elongation in ethylene was fully reversed by transforming *ETR1(1-349)* into the triple loss-of-function line, suggesting that the amino-terminal half of the receptor may play some role in modulating plant responsiveness to higher concentrations of ethylene.

In summary, the results described here establish the importance of the proposed signal output region of ETR1 in ethylene signaling. The histidine kinase domain of the receptor is required for repression of ethylene responses. The receiver domain is not required for repression of ethylene responses, but may play a negative regulatory role in

the establishment of ethylene responses. Although these data confirm a role for the histidine kinase domain in ethylene signaling, they do not directly shed light on the role of histidine kinase activity in ethylene signaling. The mutant background used for these experiments still contained ERS1, another member of ethylene receptor subfamily 1, which is predicted to contain histidine kinase activity. Thus, signaling events requiring enzymatic activity could still be mediated by ERS1. In the next chapter, I describe experiments specifically undertaken to reveal what role(s) histidine kinase activity plays in ethylene signal transduction.

## CHAPTER III

### HISTIDINE KINASE ACTIVITY PLAYS A ROLE IN THE ESTABLISHMENT OF ETHYLENE RESPONSES IN *ARABIDOPSIS*

(This chapter is based in part on a manuscript submitted for publication: Xue-Chu Zhao, Xiang Qu, Dennis E. Mathews, and G. Eric Schaller. Effect of Ethylene Pathway Mutations upon Expression of the Ethylene Receptor ETR1 from *Arabidopsis*)

#### ABSTRACT

In *Arabidopsis*, ethylene is perceived by a five-member family of receptors. As members of subfamily 1, ETR1 and ERS1 are the only two ethylene receptors possessing a functional histidine kinase domain. T-DNA insertion mutants of *ERS1* and *ETR1* were isolated: *ers1-2* is a hypomorphic allele of *ERS1*, whereas *ers1-3* and *etr1-9* are null mutant alleles of *ERS1* and *ETR1*. All the single mutants exhibited a wild-type-like growth phenotype. The *ers1;etr1* double mutant displayed a constitutive ethylene response phenotype when grown in the dark. The *ers1;etr1* green plants were dwarfed with small and epinastic leaves in the air and died without bolting. To determine whether the histidine kinase activity of ETR1 is required for ethylene signaling, I examined the ability of a kinase-inactivated form of ETR1 to rescue the *ers1;etr1* mutant phenotype. Addition of the kinase-inactivated ETR1(G2) into a background containing both *ers1-3* and *etr1-7* mutations resulted in partial ethylene insensitivity. These results indicate that subfamily 1 members play a predominant role in ethylene signaling. These results also demonstrate that the histidine kinase activity of ETR1 plays a role in the establishment of ethylene responses.

## INTRODUCTION

Living organisms have devised sophisticated signaling mechanisms for eliciting a variety of adaptive responses to their environment. Protein phosphorylation is commonly used to modulate the activity of proteins in both prokaryotic and eukaryotic cells. This process is mediated by protein kinases, which fall into three categories based on their phosphorylation targets: histidine kinases, serine/threonine kinases, and tyrosine kinases. Among these, the histidine kinases were originally identified as signaling components in bacterial two-component systems (Parkinson, 1993; Swanson et al., 1994; Stock and Mowbray, 1995). Two-component systems use a phosphorelay mechanism to transduce signals, whereby autophosphorylation of a sensor protein on a histidine residue (histidine kinase) is induced by the perceived environmental stimulus. The phosphate group from the phosphohistidine residue is then passed directly or through a histidine-containing phosphotransfer protein (Hpt), to a response regulator (RR) which is a transcription factor in many cases (Mizuno, 1998).

The *Arabidopsis* ethylene receptor family consists of five members: ETR1, ERS1, ETR2, ERS2 and EIN4 (Chang et al., 1993; Hua et al., 1995; Hua et al., 1998; Sakai et al., 1998). All five receptor members have strong sequence similarities and similar protein structures: all of them contain three transmembrane domains and a GAF domain of unknown function in the amino-terminal region. However, they also have distinct features: ETR1 and ERS1 have a highly conserved histidine kinase domain containing all the required motifs essential for kinase functionality (Chang et al., 1993; Hua et al., 1995), while other members contain a diverged domain that is predicted to lack histidine kinase activity (Hua et al., 1998; Sakai et al., 1998). Furthermore, only ETR1, ETR2 and EIN4

possess a receiver domain in their carboxy-terminal region (Chang et al., 1993; Hua et al., 1998; Sakai et al., 1998). Based on their protein sequence and structure, ethylene receptors are divided into two subfamilies: subfamily 1 consists of ETR1 and ERS1; and subfamily 2 consists of ETR2, ERS2, and EIN4.

My work described in Chapter II demonstrates that the histidine kinase domain of ETR1 is required for the repression of ethylene responses during ethylene signaling. The truncated ETR1(1-349) receptor, which lacks the histidine kinase domain, failed to rescue the constitutive ethylene response phenotype of the *etr1;etr2;ein4* triple loss-of-function mutant; on the other hand, the transgenic full-length wild-type receptor restored normal growth to the triple mutant (Chapter II). Although the histidine kinase activity of ETR1 has been demonstrated when assayed *in vitro* (Gamble et al., 1998), it is still not clear whether histidine kinase activity plays a role in ethylene signaling (Gamble et al., 2002; Wang et al., 2003).

To determine whether the histidine kinase activity plays a role in the regulation of ethylene responses requires the use of an *etr1;ers1* double loss-of-function mutant. Such a mutant eliminates both receptors predicted to contain histidine kinase activity, and can thus be used as a background to test different mutant versions of ETR1 for their ability to rescue the mutant phenotype. Although loss-of-function mutations were previously identified in *ETR1*, *ETR2*, *ERS2*, and *EIN4* (Hua and Meyerowitz, 1998), no loss-of-function mutation was found in *ERS1*. Recently, Wang et al. (2003) identified the *ers1-2* T-DNA insertion mutant allele of *ERS1* and made use of the *ers1-2;etr1* background to examine whether histidine kinase activity is involved in ethylene signaling. Based on the observation that a kinase-inactivated *ETR1* genomic clone rescued the *ers1-2;etr1* mutant



phenotype, they concluded that the histidine kinase activity of ETR1 is not required for receptor signaling. However, it was not clearly demonstrated whether *ers1-2* is a true null allele of *ERS1*.

In this chapter, I report on the isolation and analysis of three T-DNA insertion mutant alleles of *ETR1* and *ERS1*, named *etr1-9*, *ers1-2*, and *ers1-3*. My results indicate that *etr1-9* and *ers1-3* are null alleles for their genes, whereas *ers1-2* is a hypomorphic allele. An *ers1;etr1* double mutation results in a constitutive ethylene response phenotype, more pronounced than that observed in the *etr2-3;ers2-3;ein4-4* triple loss-of-function mutant or the *etr1-6;etr2-3;ein4-4;ers2-3* quadruple loss-of-function mutant reported previously (Hua and Meyerowitz, 1998). Thus the subfamily 1 members ETR1 and ERS1 appear to play more predominant roles in regulation of ethylene responses in *Arabidopsis*, than the subfamily 2 members of the receptor family. My results also provide evidence that the histidine kinase activity of ETR1 is involved in the establishment of ethylene responses in *Arabidopsis*.

## MATERIALS AND METHODS

### Plant Growth Conditions

For liquid culture, sterilized seeds were grown in 125 mL flasks which contain 50 mL of Murashige and Skoog basal media with Gamborg's vitamins (pH 5.75; Sigma, St. Louis) and 1.5% (w/v) sucrose. For phenotypic studies of the *etr1;ers1* double mutant, green plants were grown in Magenta cubes (Magenta Corporation, Chicago, IL) containing Murashige and Skoog basal media with Gamborg's vitamins (pH 5.75; Sigma,

St. Louis), 1.5% (w/v) sucrose, and 0.8% (w/v) agar. For both growth conditions, plants were maintained at 22°C under a 16-h light cycle (100  $\mu\text{E m}^{-2} \text{sec}^{-1}$ ).

### **Screening of T-DNA Insertion Mutant Alleles in *ERS1* and *ETR1***

All *Arabidopsis* T-DNA insertion mutants described in this chapter, including *ers1-2*, *ers1-3*, and *etr1-9*, were isolated from the ecotype *Wassilewskija* (WS). *ers1-2* was isolated from the 60,480 kanamycin-resistant T-DNA-tagged *Arabidopsis* lines of the University of Wisconsin *Arabidopsis* knockout facility (<http://www.biotech.wisc.edu/Arabidopsis/>). Both *ers1-3* and *etr1-9* were isolated from Wisconsin Basta population, which contains 72,960 Basta-resistant lines transformed with an activation-Tag vector, pSK1015 (Weigel et al., 2000). Both *ers1* mutants were identified with a PCR primer for the T-DNA left border (5'-CATT TATAATAACGCTGCGGACATCTAC-3') and an *ERS1*-specific primer (5'-CAGAGAGTTCTGTCACTCCTGGAAATGGT-3'). Plants containing the wild-type *ERS1* gene were identified by use of PCR with the above *ERS1* primer and a second *ERS1*-specific primer (5'-CACAACCGCGCAAGAGACTTTAGCA ATAGT-3'). The *etr1-9* mutant was identified by a PCR-based method using an *ETR1*-specific primer (5'-GCGGTTGTTAAGAAATTACCCATCACA CT-3') and the same T-DNA left border primer as described above. Plants containing the wild-type *ETR1* gene were identified by use of PCR with the above *ETR1* primer and a second *ETR1*-specific primer (5'-ATCCAAATGTTACCCTCCATCAGATTCAC-3'). Initial screens were done by Dr. Dennis E. Mathews (Department of Plant Biology, University of New Hampshire). I then identified homozygous lines for each individual mutant carrying the specific T-DNA insertion.

### **Genetic Analysis of *ers1* and *etr1* T-DNA Insertional Mutants**

To generate *ers1;etr1* double mutants, the *ers1-2* mutant was crossed to the *etr1-7* mutants, and the *ers1-3* mutant was crossed to the *etr1-7* and *etr1-9* mutants, respectively. For genotyping the *ers1-2*, *ers1-3*, and *etr1-9* mutations, PCR was performed using the T-DNA left-border primer and the gene-specific primer as described previously. The *etr1-7* mutation was identified by PCR-based genotyping of F<sub>2</sub> progeny from the crossed plants according to Hua and Meyerowitz (1998).

To analyze the histidine kinase activity of ETR1 in ethylene signaling, the *ers1-3* mutant was crossed to an *etr1-7* mutant which also contains a transgenic version of ETR1 lacking histidine kinase activity [*ETR1(G2)*] (Gamble et al., 2002). PCR-based genotyping was used to identify the mutations of *etr1-7*, *ETR1(G2)*, and *ers1-3*. To prepare genomic DNA samples for PCR, a SHORTY DNA Quick-Prep method was modified to extract DNA from leaf tissues and etiolated seedlings with a CTAB DNA extraction buffer (for reviews, visit <http://www.biotech.wisc.edu/NewServicesandResearch/Arabidopsis/FindingYourPlantIndex.html>). The CTAB extraction buffer contains 2% (w/v) CTAB (hexadecyl trimethyl-ammonium bromide), 1.4 M NaCl, 100 mM Tris-HCl (pH 8.0), 20 mM EDTA, and 100 mM β-mercaptoethanol (added fresh before use). For the *etr1-7* mutation, *etr1-1-F* (5'-GGTGCTTTTATCGTTCTTTA-3') was paired with *ETR1-B* (5'-GCGAGGCCAAGCC-3') in PCR. Conditions for amplifications were as follows: 30 s at 94°C, 30 s at 51°C, and 2 min at 72°C. The cycle was repeated 45 times, preceded by 3 min at 94°C, and followed by 5 min at 72°C. PCR with the primer set of *ETR1-B* and *ETR1-F* (5'-GGTGCTTTTAT CGTTTG-3') would amplify the wild-type allele, but not the mutant alleles *etr1-1* or *ETR1(G2)*. Conditions

for amplifications were as follows: 30 s at 94°C, 30 s at 61°C, and 2 min at 72°C. The cycle was repeated 45 times, preceded by 3 min at 94°C, and followed by 5 min at 72°C. To determine the presence of *ETR1(G2)* in the mutant plants, *ETR1(G2)*-F (5'-TAGTGCGCTTGC-3') was combined with *ETR1(G2)*-B (5'-TTGTCAGTGTTACCA-3') as primers for PCR. Conditions for amplifications were as follows: 30 s at 94°C, 30 s at 46°C, and 2 min at 72°C. The cycle was repeated 45 times, preceded by 3 min at 94°C, and followed by 5 min at 72°C. For the *ers1-3* mutation, the same approach was used as described in the earlier method.

### **RNA Isolation**

For Figure 15, total RNA was isolated from 15-day-old leaf tissue of plants grown in liquid culture according to Carpenter and Simon (1998). mRNA was then purified from total RNA using the PolyAtract mRNA isolation system (Promega, Madison, WI) according to the manufacturer's instructions.

For Figure 16, total RNA was isolated from 4-day-old *Arabidopsis* etiolated seedlings by a modification of the method described by Carpenter and Simon (1998) using TRIzol<sup>®</sup> Reagent (Gibco BRL, Grand Island, NY). Total RNA was then used for northern-blot analysis without further purification.

### **Northern Blot Analysis**

RNA was separated on 1% (w/v) agarose gels using the NorthernMax-Gly system (Ambion, Austin, TX). Separated RNAs were transferred to the MagnaCharge nylon membrane (GE Osmonics, Minnetonka, MN) by the capillary method and fixed by UV-

cross linking using GS Gene Linker UV Chamber (Bio-Rad Laboratories). Single-stranded DNA antisense probes were made using primers designed to anneal at the 3' end of the selected genes. For the *ETR1* probe, *DraI*-digested pBLUE-cETR1 was used as the PCR template (Zhao et al., 2002). For the *ERS1* probe, *SpeI*-digested pBLUE-ERS1 was used as the PCR template (Zhao et al., 2002). The primers used for PCR were ERS1a-B (5'-ACTAGTGACTGTCAGTACTGAGAA-3') and ETR1-reverse (5'-ATCCAAATGTACCCTCCATCAGATTAC-3'). Radio-labeled probes were made and stripped between hybridizations by using the Strip-EZ PCR system from Ambion according to the manufacturer's manual. Radioactivity was imaged and quantified by phosphor imaging with a Molecular Imager FX (Bio-Rad Laboratories), using the accompanying Quantity One software.

### **Protein Isolation, Separation, and Western Blot Analysis**

To isolate membrane protein, seedlings were homogenized in extraction buffer (50 mM Tris, pH 8.5, 150 mM NaCl, 10 mM EDTA, 20% [v/v] glycerol). Protease inhibitors [1 mM phenylmethylsulfonyl fluoride (PMSF), 1 µg/mL pepstatin, 10 µg/mL leupeptin, and 10 µg/mL aprotinin] were included to prevent protein degradation. The homogenate was first filtered through Miracloth (Calbiochem-Novobiochem, San Diego, CA) and then centrifuged at 8,000 g for 15 minutes. The supernatant was centrifuged at 100,000g for 30 min. The membrane pellet was resuspended in resuspension buffer (10 mM Tris, pH 7.5, 150 mM NaCl, 1 mM EDTA, and 10% [v/v] glycerol) with protease inhibitors. Procedures described above were all done at 4°C. Protein concentration was then determined by a modification of the Lowry assay (Lowry et al., 1951) in which

samples were treated with 0.4% (w/v) sodium deoxycholate (Schaller and DeWitt, 1995).

Bovine serum albumin was used in preparing a standard curve.

Membrane proteins were mixed with 2x SDS-PAGE loading buffer [125 mM Tris-HCl (pH 6.8), 4% (w/v) SDS, 20% (v/v) glycerol, and 0.01% (w/v) bromphenol blue] containing 100 mM DTT. After incubation at 50°C for 1 hour, proteins were separated by SDS-PAGE using an 8% (w/v) polyacrylamide gel (Laemmli, 1970). Precision Plus Protein *all blue* Standards were included as molecular weight markers (Bio-Rad Laboratories). Separated proteins were electro-transferred to and immobilized on Immobilon nylon membrane (Millipore, Bedford, MA). Western-blot analyses were performed with the  $\alpha$ ETR1(165-400) and  $\alpha$ ETR1(401-738) antibodies (Gamble et al., 2002). Immunodecorated proteins were visualized by a diluted (1:10 [v/v]) SuperSignal<sup>®</sup> West Femto Maximum Sensitivity Substrate system according to the manufacturer's instructions (Pierce Chemical, Rockford, IL). Densitometric analyses of immunodecorated bands were performed using NIH Image (version 1.6, National Institute of Health, Bethesda, MD) after first scanning the exposed film using Photoshop (version 5.5, Adobe Systems, Mountain View, CA) and an Epson 1240U scanner. The relative expression level for ETR1 was quantified by comparison to a dilution series of ETR1.

### **Ethylene Growth Response Assay**

To examine the triple response of seedlings to ethylene (Chen and Bleecker, 1995; Hall et al., 1999), seeds were grown on Petri plates. 5  $\mu$ M of aminoethylvinyl-glycine (AVG) was included in growth media to inhibit ethylene biosynthesis by seedlings. Plates

were placed in 4.5-liter sealed containers with 0 to 1000  $\mu\text{L L}^{-1}$  ethylene. To examine seedlings growing in the absence of ethylene, hydrocarbon-free air was passed through the container to remove any ethylene synthesized by the seedlings. All containers were kept in the dark at 22°C. Seedlings were examined after 4 d, with time 0 corresponding to the time when the plates were removed from 4°C and brought to 22°C. To measure hypocotyl length, seedlings were grown on vertically oriented square plates. Seedlings were scanned by use of Photoshop (version 5.5, Adobe Systems, Mountain View, CA) and an Epson 1240U scanner, and hypocotyl length was then measured in NIH Image (version 1.6, National Institute of Health, Bethesda, MD).

### **Constructs for Plant Transformation**

All *ETR1* constructs were driven by the native genomic promoter (Figure 14). The *ETR1-FL* construct represents a genomic copy of wild-type *ETR1* (Gamble et al., 2002); *ETR1(G2)* is full-length genomic sequence containing a mutated G2 box (G545A and G547A) (Gamble et al., 2002), which results in abolishment of the histidine kinase activity (Gamble et al., 2002). *ETR1(1-603)* encodes a truncated receptor lacking the receiver domain alone (Chapter II).

The G2-box mutation will only eliminate the kinase activity of the ETR1 receptor itself; however, it will not prevent the highly conserved phosphorylation sites (His353 and Asp659) from being phosphorylated by other histidine kinases. To elucidate the importance of the histidine kinase activity in ethylene signaling, two new site-directed *ETR1* mutant constructs were made [*ETR1(HG2)* and *ETR1(HG2D)*]. *ETR1(HG2)* represents a full-length genomic version of *ETR1* in which the G2-box and the

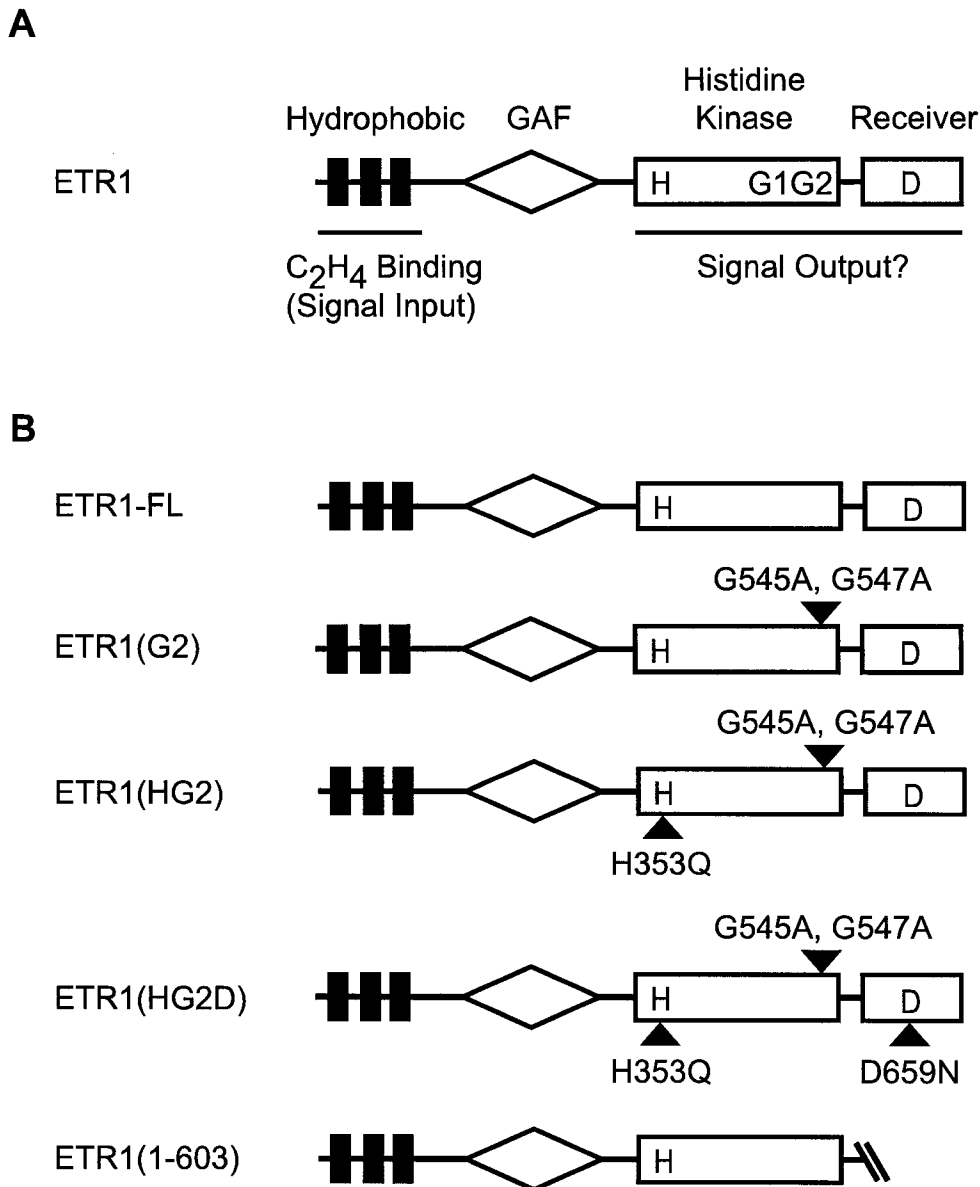

**Figure 14.** Structure of ETR1 and constructs used for experimental analysis. **A.** Domains of the full-length ETR1 protein. The hydrophobic ethylene-sensing domain, the GAF domain, the histidine kinase domain, and the receiver domain are indicated. H indicates His-353 and D indicates Asp-659, the putative phosphorylation sites. G1 and G2 indicate positions of the G1 and G2 boxes within the kinase domain. The proposed signal output region consists of the histidine kinase domain and the receiver domain. **B.** Versions of ETR1 expressed as transgenes in *Arabidopsis*. For mutations, H refers to H353Q, G2 refers to G545A, G547A, and D refers to D659N.



autophosphorylated His (H353Q) are mutated. *ETR1(HG2D)* has mutations in the G2-box, autophosphorylated His, and the Asp residue within the receiver domain (D659N). For construction of these mutant versions of *ETR1*, the *ETR1(G2)* genomic clone (Gamble et al., 2002) was subcloned into pALTERII and mutation made using the Altered Site Mutagenesis System (Promega). The following primers were used for mutagenesis: ETR1-H353Q (5'-CTAGCGGTTATGAACCAAGAAATGCGAACACC-3'), and ETR1-D659N (5'-CAAAGTGGTCTTCATGAAGGTGTGCATGCCC-3').

## RESULTS

### **Isolation and Characterization of the T-DNA Insertion Mutant *ers1-2*, a Hypomorphic Allele of *ERS1***

With the exception of *ERS1*, loss-of-function mutations have been isolated for all of the ethylene receptor family members (Hua and Meyerowitz, 1998). *ERS1* and *ETR1* are the most closely related of all the members of the ethylene receptor family in *Arabidopsis*, and they are the only ethylene receptors containing all the highly conserved motifs considered essential for histidine kinase activity (Chang and Stadler, 2001; Schaller and Kieber, 2002). To elucidate whether histidine kinase activity is involved in ethylene signaling, it is important to isolate a loss-of-function mutant allele of *ERS1*. Dr. Dennis E. Mathews, a research assistant professor working in our lab, identified a mutant line containing a T-DNA insertion within the 5'-UTR (untranslated region) of *ERS1* (Fig. 15A). The sequence at the T-DNA junction with *ERS1* was ATAACGCTCGGATCAATC Atactcga(atattcaattgtaaattggct), with capitals indicating *ERS1* sequence and parentheses indicating T-DNA left border sequence. I identified a homozygous line carrying the

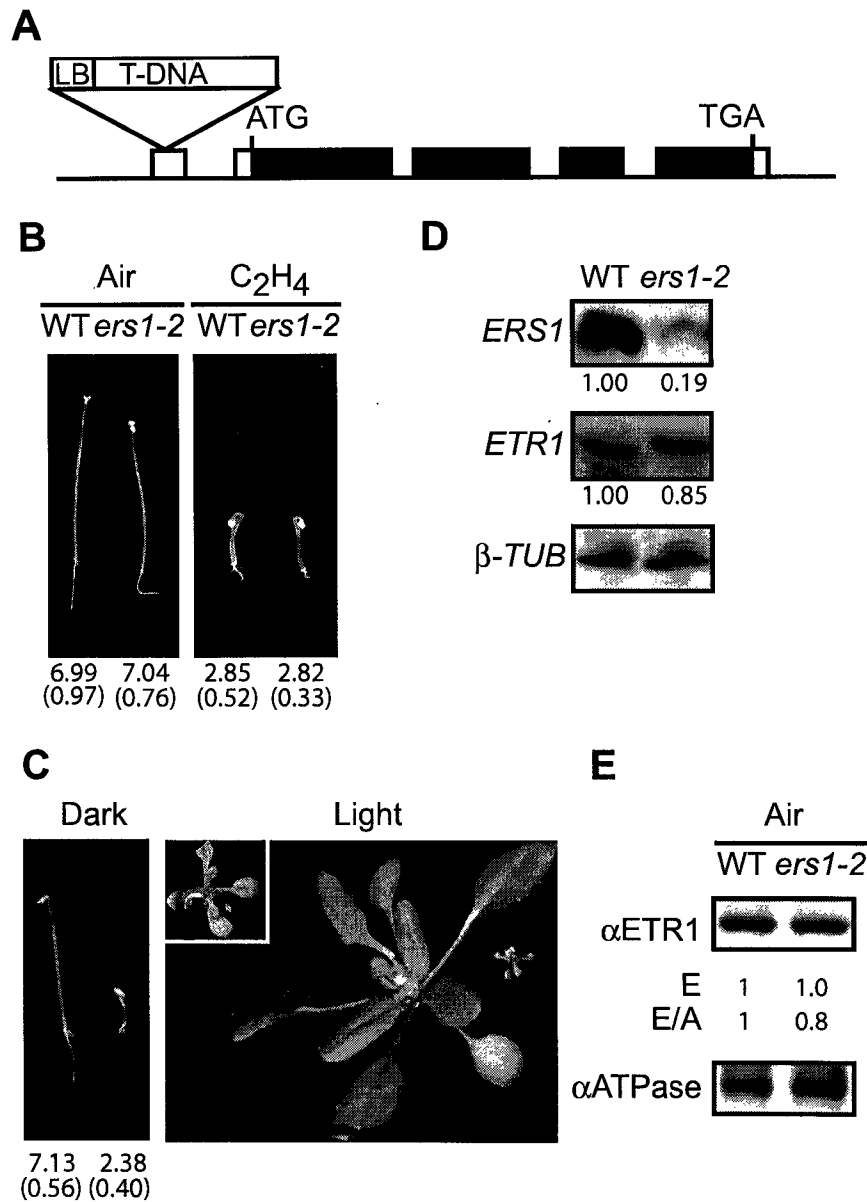

**Figure 15.** Analysis of the T-DNA insertion mutant *ers1-2* (modified from Zhao et al., 2002). **A**, Location of T-DNA insertion in the *ERS1* gene. Black bars and white bars represent translated and untranslated regions of the *ERS1* transcript, respectively. **B**, Phenotype of 3.5-day-old dark-grown seedlings containing the *ers1-2* mutation grown in air or ethylene ( $100 \mu\text{L L}^{-1}$ ). Mean hypocotyl lengths are given in millimeters with SD in parentheses. **C**, Phenotype of the *ers1-2;etr1-7* double mutant as compared with seedlings with wild-type phenotype segregating from the same population. Seedlings were grown in dark for 3.5 d or in the light for 4 weeks. The *ers1-2;etr1-7* double mutant is on the right in each panel, and a 2-fold enlargement is also inset to reveal details of the light-grown seedling. **D**, Northern-blot analysis of *ERS1* and *ETR1* expression in the *ers1-2* mutant line performed using 25  $\mu\text{g}$  of total RNA. The numbers represent the expression level of the ethylene receptor genes after normalization for the level of  $\beta$ -tubulin expression. **E**, Effect of the *ers1-2* mutation upon expression of *ETR1* in etiolated seedlings. Immunoblot analysis was performed using antibodies directed against *ETR1* and the  $\text{H}^+$ -ATPase as an internal control on 15  $\mu\text{g}$  of membrane protein. Expression levels are given based directly upon that determined with  $\alpha$ ETR1 antibody (E) and normalized against the ATPase levels (E/A).

specific T-DNA insertion by conducting PCR analysis with T-DNA-specific and gene-specific primers. This mutation was designated *ers1-2* [*ers1-1* referring to a previously isolated ethylene insensitive allele of *ERS1* (Hua et al., 1995)].

The *ers1-2* mutant plants exhibit a wild-type-like growth phenotype (Figure 15B). I therefore crossed *ers1-2* with the *etr1-7* mutant, a loss-of-function mutant allele of *ETR1* that also has a phenotype close to wild-type. The *ers1-2;etr1-7* double mutation resulted in a constitutive ethylene-responsive phenotype (Figure 15C). The *ers1-2;etr1-7* etiolated seedlings displayed a triple-response phenotype in air, *i.e.*, in the absence of ethylene. When grown in the light, the *ers1-2;etr1-7* plants were dwarfed with small and epinastic leaves in the air and some of them died without bolting.

To determine whether the T-DNA insertion completely disrupted the expression of *ERS1*, northern-blot analysis was conducted. A substantial reduction in mRNA levels for *ERS1* in the *ers1-2* background compared to that found in wild-type plants was detected. However, low levels of transcripts were still detected. Thus *ers1-2* is predicted to be a hypomorphic allele of *ERS1*, rather than a complete loss-of-function mutation (Figure 15D). The significant reduction of *ERS1* transcript levels in the *ers1-2* mutant would contribute to the strong mutant phenotype observed when the *ers1-2* mutant was combined with the *etr1-7* mutant.

Loss of one member in a gene family can sometimes lead to functional compensation, whereby expression of another member of the same gene family is induced to compensate for activity of the missing family member (Berard et al., 1997; Mulligan et al., 1998; Minkoff et al., 1999). An intriguing set of experiments suggests that functional compensation occurs within the ethylene receptor family of tomato (Tieman et al., 2000).

Therefore, the lack of a mutant phenotype in the *ers1-2* mutant by itself could potentially be due to functional compensation by other members of the ethylene receptor family in *Arabidopsis*, especially by ETR1 because of their sequence similarity. However, the expression of *ETR1* in the *ers1-2* mutant background was comparable with that found in the wild-type background at both the mRNA and protein levels (Figure 15 D and E), indicating that the lack of a mutant phenotype in *ers1-2* was not because of changes in *ETR1* expression.

### **Isolation of Two Additional T-DNA Insertion Mutants (*ers1-3* and *etr1-9*) of *ERS1* and *ETR1***

To obtain additional T-DNA insertion mutants of *ERS1* and *ETR1*, Dr. Mathews screened the Wisconsin Basta population representing 72,960 T-DNA insertion lines (<http://www.biotech.wisc.edu/Arabidopsis/>). A line was identified that contained a T-DNA insertion within the second exon of *ERS1* (Figure 16A). The sequence at the T-DNA junction in *ERS1* was ATACTATTTTAAGAACCACaatgagtaaata(taaatggcgacatgtccggg), with capitals indicating *ERS1* sequence and parentheses indicating T-DNA left border sequence. This mutation was named *ers1-3*. I identified a homozygous *ers1-3* line and performed northern-blot analysis to determine whether *ers1-3* is a null mutant allele of *ERS1*. No transcript was detected for *ERS1* in *ers1-3*, consistent with *ers1-3* being a null allele (Figure 16B). Western-blot analysis demonstrated that the expression level of ETR1 remained the same in both the wild-type and *ers1-3* backgrounds, suggesting that ETR1 did not functionally compensate for the loss of ERS1 (Figure 16C).

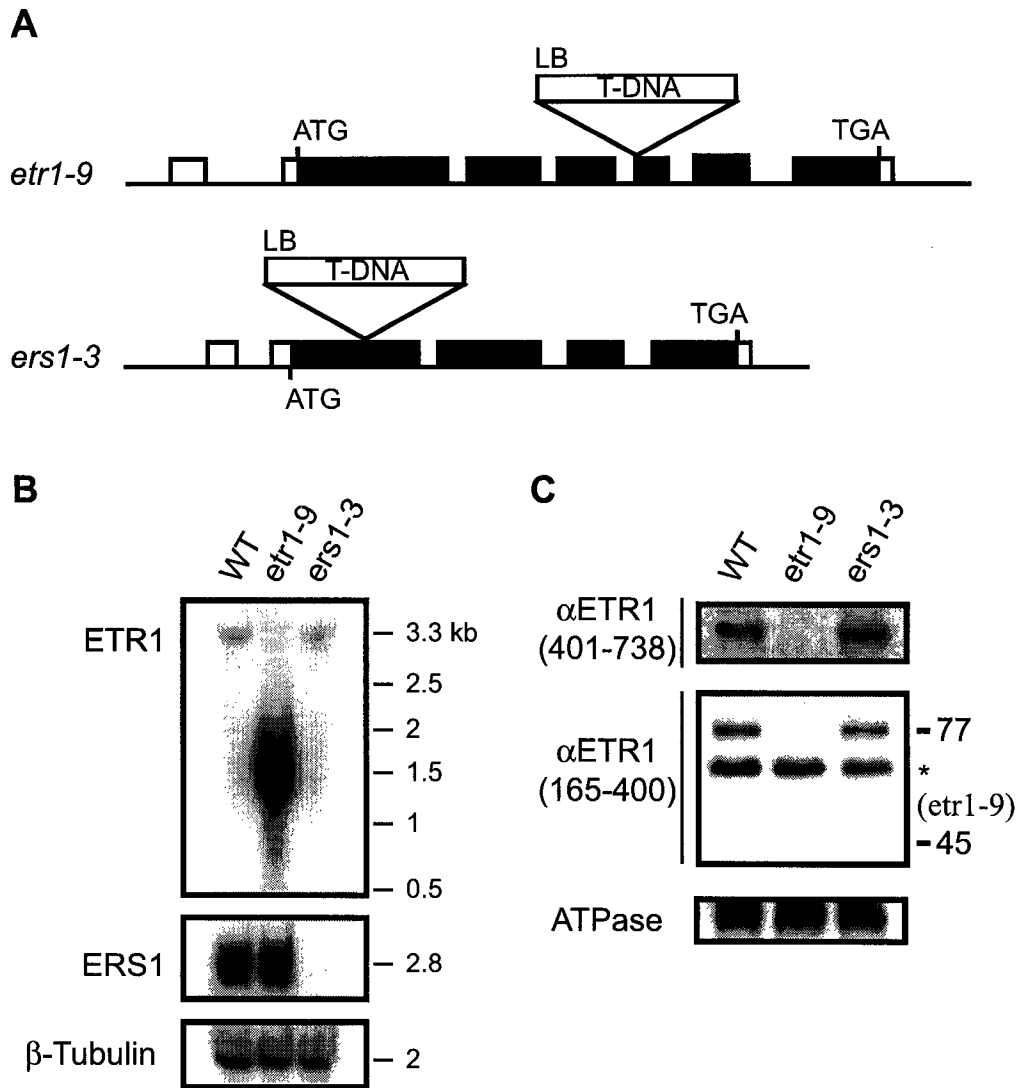
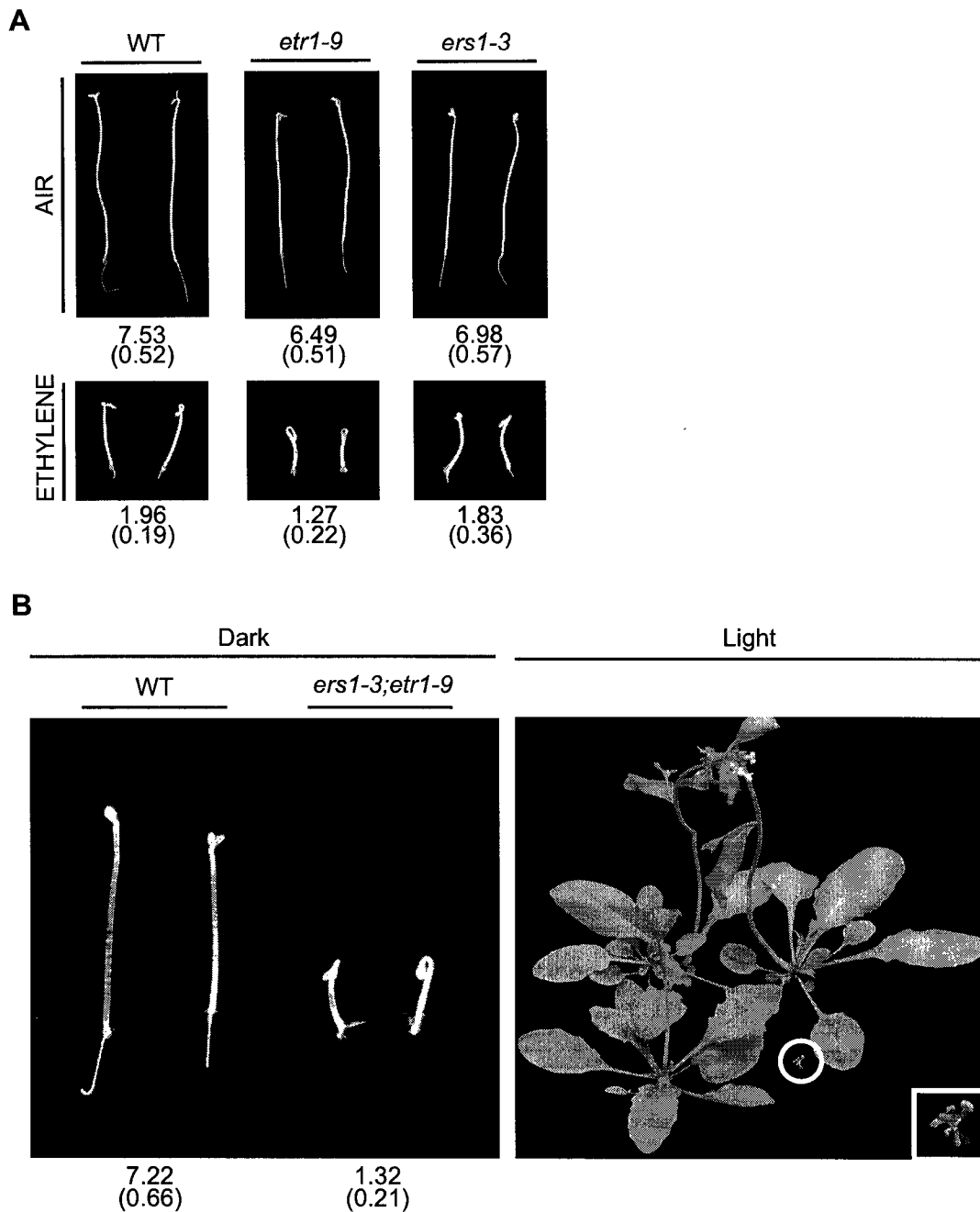

**Figure 16.** *etr1-9* and *ers1-3* are null mutant alleles of *ETR1* and *ERS1*. **A**, Location of T-DNA insertions in *ETR1* and *ERS1*. Black bars and white bars represent translated and untranslated regions, respectively. **B**, Northern-blot analysis of *ETR1* and *ERS1* expression in both T-DNA insertion mutant lines performed using 25  $\mu$ g of total RNA. Numbers indicate positions of RNA standards. **C**, Immunoblot analysis of ETR1 in both *etr1-9* and *ers1-3* mutant backgrounds. Membrane fractions (10  $\mu$ g) from etiolated *Arabidopsis* seedlings were analyzed by immunoblot using the  $\alpha$ ETR1(165-400) and  $\alpha$ ETR1(401-738) antibodies. The wild-type ETR1 receptor migrates at a molecular mass of 77 kD. The predicted migration position of the hypothetical *etr1-9* truncated receptor (58 kD) is indicated. Asterisk indicates a nonspecific cross-reacting protein migrating at a molecular mass of 65 kD.

In the same T-DNA population, a line was identified that contained a T-DNA insertion within the fifth exon of *ETR1* (Figure 16A). The sequence at the T-DNA junction in *ETR1* was GGTA<sup>A</sup>AAGACTCTGGAGC<sup>tcca</sup>, with capitals indicating *ETR1* sequence and lower case indicating random sequence between *ETR1* and left border of T-DNA. We named this mutant allele *etr1-9* to differentiate it from the previously identified *etr1-5*, *etr1-6*, *etr1-7*, and *etr1-8* loss-of-function mutants (Hua and Meyerowitz, 1998). Northern blot analysis indicated that no full-length *ETR1* message was made in the *etr1-9* mutant seedlings (Figure 16B). However, a high level of truncated transcripts was found at a lower molecular weight (Figure 16B). To determine whether any truncated protein was made, western-blot analysis was performed. No full-length or truncated ETR1 receptor was detected (if present, the truncated *etr1-9* protein was predicted to consist of 515 amino acids with a molecular weight of 58 kD) (Figure 16C). Therefore, *etr1-9* is a null mutant allele of *ETR1*.

#### **Quantitative Analysis of the Ethylene-Induced Seedling Growth Response in Single *etr1-9* and *ers1-3* T-DNA Insertion Mutants**

Both the *etr1-9* and *ers1-3* T-DNA insertion mutants displayed growth phenotypes similar to wild-type (Figure 17A). To gain quantitative information about their ethylene responses, ethylene dose response analyses were performed for *ers1-2*, *ers1-3*, and *etr1-9*. Homozygous etiolated seedlings were grown in air and in ethylene at different concentrations ranging from 0 to 1000  $\mu\text{L L}^{-1}$ . Hypocotyl length was measured after 3.5-day growth and compared with a wild-type *Wassilewskija* (WS) control. As shown in Figure 18, all three T-DNA insertion mutants exhibited a slight increased sensitivity to



**Figure 17.** Phenotypic analysis of the T-DNA insertion mutant alleles of *ETR1* and *ERS1*. **A**, Phenotype of 3.5-d-old dark-grown seedlings from the *etr1-9* and *ers1-3* mutant lines grown in the absence of ethylene (AIR) or in the presence of 100  $\mu\text{L L}^{-1}$  ethylene (ETHYLENE). Mean hypocotyl lengths were given in millimeters with SD in parentheses. **B**, Phenotype of the *ers1-3;etr1-9* double mutant as compared with seedlings with wild-type phenotype segregating from the same population. Seedlings were grown in dark for 3.5 d or in the light for 4 weeks. The *ers1-2;etr1-7* green plant is high-lighted by the white circle and a 4-fold enlargement is also inset at the lower right corner to reveal details of the light-grown seedling.

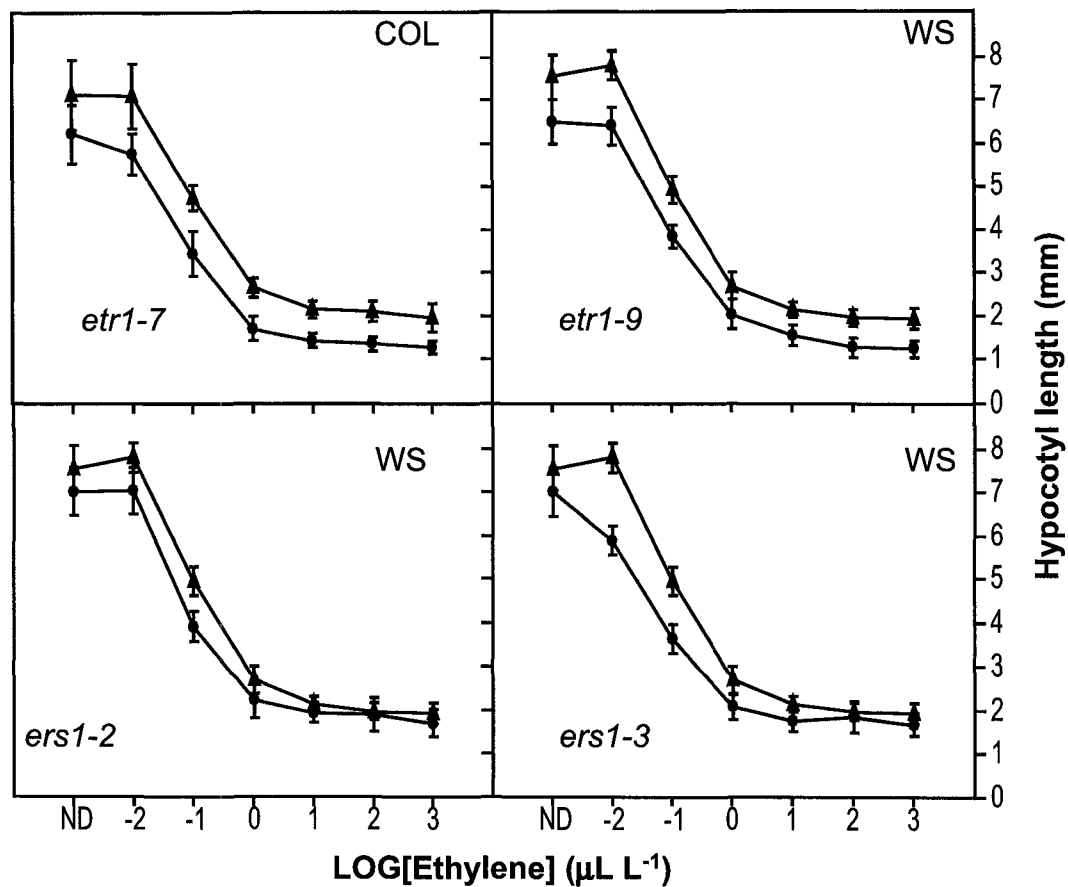

**Figure 18.** Ethylene dose response curves of hypocotyl growth for the *etr1-7*, *etr1-9*, *ers1-2*, and *ers1-3* mutants. The *etr1-7* mutant is of the ecotype Columbia (COL). The *etr1-9*, *ers1-2*, and *ers1-3* mutants are of the ecotype of Wassilewskija (WS). Dose response curves for each mutant are shown (black circle). For comparison, ethylene dose response curves are shown for control wild-type (black triangle, COL for *etr1-7* and WS for *etr1-9*, *ers1-2*, and *ers1-3*) hypocotyls. Values represent the means  $\pm$  SD of at least 25 measurements. ND, No detectable ethylene.



ethylene when compared to the wild-type control. The *etr1-9* mutant seedlings also displayed increased ethylene responsiveness in comparison with wild-type at all tested ethylene concentrations, which is consistent with analysis of the previously identified *etr1-7* loss-of-function mutant (Hua and Meyerowitz, 1998; Cancel and Larsen, 2002). The *ers1-3* mutant showed slightly greater ethylene sensitivity than *ers1-2*, which could be due to the presence of low levels of *ERS1* in the *ers1-2* background (Gamble et al., 2002).

### **Analysis of *ers1*;*etr1* Double Mutants**

Double mutants were constructed by crossing *ers1-3* with *etr1-7* and with *etr1-9*. It should be noted that *ers1-3* and *etr1-9* are of the WS ecotype, but that *etr1-7* is of the *Columbia* ecotype. Both the *ers1-3*;*etr1-9* and the *ers1-3*;*etr1-7* double mutations had pronounced effects upon plant growth and development. When grown in the dark, homozygous double mutant seedlings displayed a constitutive ethylene-response phenotype with shortened shoots and roots, and with an exaggerated apical hook (Figure 19B). When grown under light, the *ers1-3*;*etr1-9* plants were dwarfed with small and epinastic leaves in the air and died without bolting (Figure 19B).

When compared to the *ers1-2*;*etr1-7* double mutant, etiolated seedlings from both the *ers1-3*;*etr1-7* and *ers1-3*;*etr1-9* double mutants possessed shorter hypocotyls (about 40% shorter than those of *ers1-2*;*etr1-7*). In addition, both the *ers1-3*;*etr1* mutants produced exaggerated apical hooks; these were not observed in the *ers1-2*;*etr1-7* mutant seedlings (Figure 19A). Light-grown *ers1-3*;*etr1-7* and *ers1-3*;*etr1-9* plants were smaller in rosette size when compared to the *ers1-2*;*etr1-7* plants (Figure 19B). In addition, *ers1-*

**A**

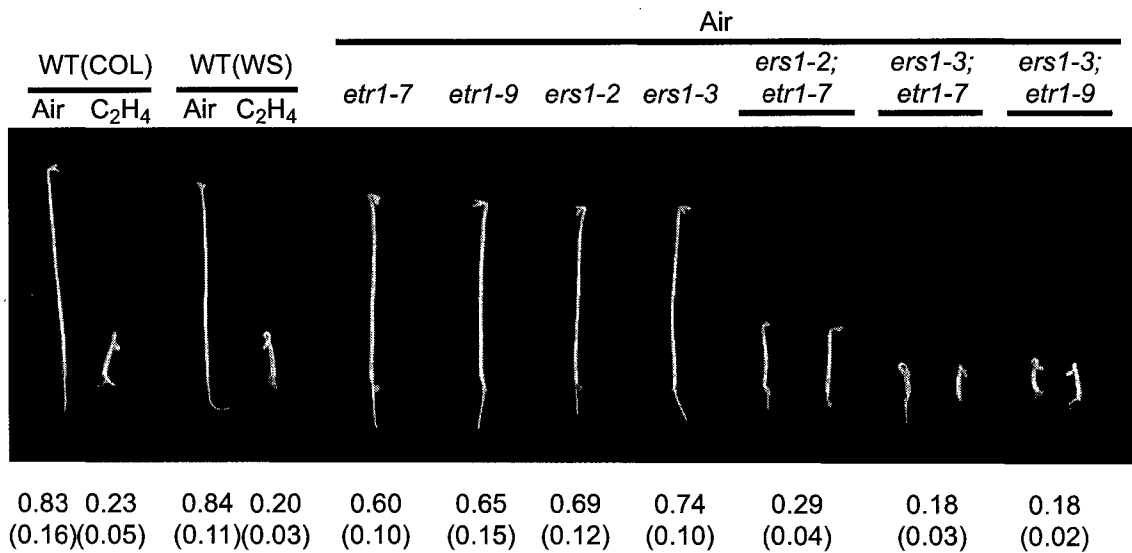

**B**

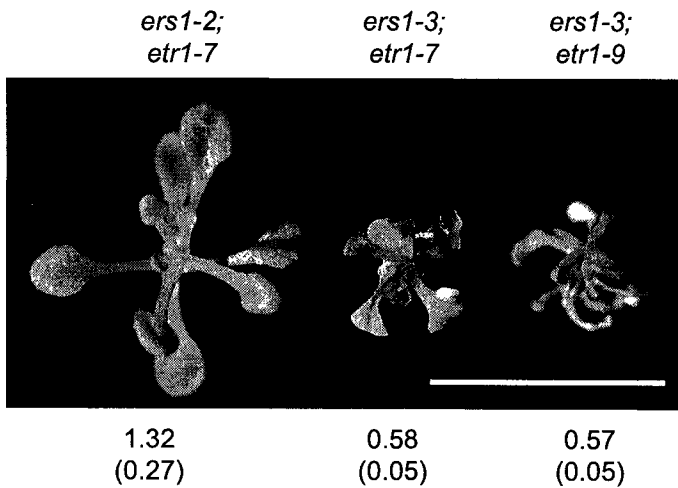

**Figure 19.** Effects of *etr1* and *ers1* mutations upon plant growth. **A**, Effects of single and double mutations of the subfamily 1 receptors upon seedling growth. *etr1-7* was isolated from the ecotype Columbia (COL), whereas *etr1-9*, *ers1-2*, and *ers1-3* were isolated from the ecotype Wassilewskija (WS). Seedlings were grown in the dark for 3.5 days either in air or in the presence of ethylene. Mean hypocotyl lengths are given in centimeters with SD in parentheses. **B**, Effects of *ers1;etr1* double mutations upon rosette size. Green plants were grown on MS media with 1.5% (w/v) sucrose. Rosette diameters were measured for 8-week-old plants ( $n > 11$  plants). Mean rosette diameters are given in centimeters with SD in parentheses. White bar = 1 cm.

*3;etr1-7* and *ers1-3;etr1-9* mutants failed to bolt whereas *ers1-2;etr1-7* plants were still capable of bolting and flowering although with a substantial delay compared to wild-type (Hall and Bleecker, 2003; Wang et al., 2003). After 60-d growth under 16-h light cycle, none of the sixteen *ers1-3;etr1-7* and eighteen *ers1-3;etr1-9* plants had bolted. In contrast, eight out of eleven *ers1-2;etr1-7* mutant plants had bolted.

### **Ethylene Delays Bolting in *Arabidopsis***

The *ers1-3;etr1* double loss-of-function mutant plants did not bolt, and consequently did not flower during their life cycle. To determine whether this mutant phenotype is consistent with a modification of ethylene signaling, the effect of ethylene upon shoot development in wild-type and *ctr1-2* plants was determined. *ctr1-2* is a constitutive ethylene response mutant allele of *CTR1*, and thus already displays an enhanced ethylene responses (Kieber et al., 1993). The effect of ethylene upon shoot formation was assessed based on bolting time, the number of rosette leaves, and the diameter of the rosette (Figure 20A, Table 1). For these studies, all data were collected immediately after formation of the primary shoot.

A substantial delay in shoot formation was observed upon ethylene treatment. In the absence of ethylene, *ctr1-2* mutant plants bolted about one-week later than COL (average 25 days for *ctr1-2* vs. 18 days for COL). In the presence of ACC (ethylene biosynthesis precursor), both COL and *ctr1-2* plants exhibited about a 1.5-fold delay in bolting time, compared to their untreated counterparts. Data obtained from the analysis of rosette leaf number showed a similar trend. Wild-type COL produced an average of 9 rosette leaves in the absence of ethylene and 24 when treated with ACC. *ctr1-2* mutant

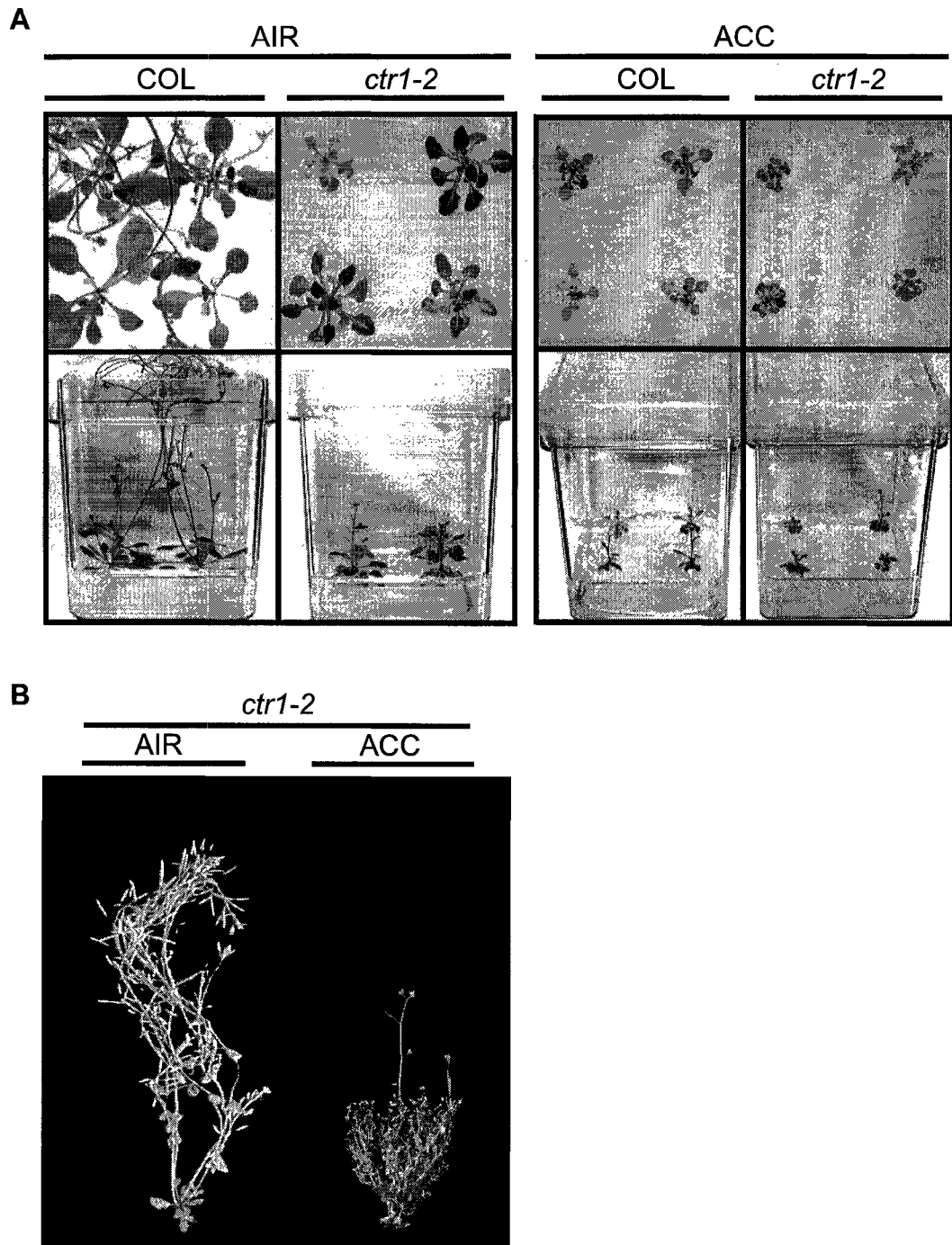

**Figure 20.** Effect of ACC upon growth of wild-type *Columbia* (COL) and the *ctr1-2* mutant. **A**, Morphological features of wild-type and the *ctr1-2* mutant. Representative green plants from wild-type (COL) and the *ctr1-2* mutant line are shown after 4-week growth in air and 5-week growth in the presence of 5  $\mu$ M ACC. **B**, Prolonged treatment of ACC results in a "bushy" growth phenotype of the *ctr1-2* plants.

**Table 1.** Ethylene effect upon shoot formation

Green plants were grown under a 16-h light cycle in the presence or absence of ACC. AVG was included in growth media to reduce the effect from endogenous ethylene. Each value is the average  $\pm$  standard deviation for > 30 plants.

	Bolting time (day)	Rosette Diameter (mm)	Leaf Number
COL (AVG)	18.38 $\pm$ 2.14	51.93 $\pm$ 6.01	9.62 $\pm$ 1.59
COL (AVG+ACC)	26.53 $\pm$ 2.58	18.37 $\pm$ 3.38	14.23 $\pm$ 2.79
ctr1-2 (AVG)	24.63 $\pm$ 3.44	19.74 $\pm$ 2.05	13.06 $\pm$ 1.25
ctr1-2 (AVG+ACC)	38.63 $\pm$ 4.14	10.86 $\pm$ 3.28	47.36 $\pm$ 9.40

plants produced 15 rosette leaves in the absence of ethylene and 47 when treated with ACC. Ethylene also had inhibitory effects upon rosette size. In the absence of ethylene, the rosette diameter of wild-type COL was 52 mm whereas that of *ctr1-2* averaged 20 mm. In the presence of ACC, the rosette diameter of COL reduced to 18 mm whereas that of *ctr1-2* averaged only 11 mm. In addition, *ctr1-2* mutant plants displayed a “bushy” growth phenotype upon prolonged treatment with ACC (Figure 20B).

Thus, ethylene delays bolting in *Arabidopsis*. The more pronounced delay observed in the *ctr1-2* mutant plants when compared to wild-type results from the fact that the mutant plants already have an enhanced ethylene response. The lack of bolting observed in the *ers1;etr1* double loss-of-function mutant is consistent with what might be expected under conditions of an extreme ethylene response.

### **A Role for Histidine Kinase Activity in Ethylene Signaling**

The *ers1-3;etr1* double mutants displayed a constitutive ethylene response phenotype, more pronounced than that reported for the *etr2-3;ein4-4;ers2-3* triple mutant and the *etr1-6;etr2-3;ein4-4;ers2-3* quadruple mutant (Hua and Meyerowitz, 1998). Thus, compared to the subfamily 2 receptor members, the subfamily 1 members ETR1 and ERS1 play more predominant roles in the regulation of ethylene responses in *Arabidopsis*. Since the subfamily 2 members (ETR2, ERS2, and EIN4) are predicted to lack histidine kinase activity, one could speculate that the histidine kinase activity of subfamily 1 members may be involved in the regulation of ethylene responses.

To examine whether the histidine kinase activity of ETR1 plays a role in ethylene signaling, *ers1-3* was crossed to a homozygous *etr1-7* line containing the *ETR1(G2)*

transgene. *ETR1(G2)* is a kinase-inactivated mutant allele of *ETR1* (Gamble et al., 2002). If kinase activity is required for the repression of ethylene responses, addition of the *ETR1(G2)* transgene will not be able to rescue the constitutive ethylene phenotype of the double mutant. In contrast, if *ETR1(G2)* does rescue the double mutant phenotype, then the question is whether the kinase activity is involved in the establishment of ethylene responses. If so, a subset of progeny from this cross would be insensitive to ethylene.

To determine if the kinase activity might be involved in the establishment of ethylene responses, F<sub>2</sub> progeny were screened on Petri plates containing plant growth medium and 5 μM ACC. After a 4-d growth in the dark, a subset of seedlings were observed that had an elongated hypocotyl. PCR-based genotyping revealed that 9 selected seedlings with “long hypocotyl” were either homozygous at *etr1-7* and heterozygous at *ers1-3* (8 seedling), or homozygous at *ers1-3* and heterozygous at *etr1-7* (1 seedlings). All these seedling also contained the *ETR1(G2)* transgene. Three of these seedlings (2 homozygous at *etr1-7* and 1 homozygous at *ers1-3*) were carried to the next generation. F<sub>3</sub> progeny were screened against 10 μL L<sup>-1</sup> ethylene (a more stringent condition) for those with long hypocotyls. A higher frequency of elongated seedlings was observed: about 2/3 of the tested F<sub>3</sub> progeny exhibited reduced ethylene sensitivity. The five tallest seedlings from each line were selected and subjected for genotyping. For the homozygous *etr1-7* parent, all tall progeny was homozygous at *etr1-7* and heterozygous at *ers1-3*, and contained the *ETR1(G2)* transgene. For the homozygous *ers1-3* parent, all tall progeny was homozygous at *ers1-3* and heterozygous at *etr1-7*, and contained the *ETR1(G2)* transgene. No homozygous *ers1-2;etr1-7* seedlings carrying the *ETR1(G2)* transgene were identified (Figure 21A). In the presence of ethylene, these “long

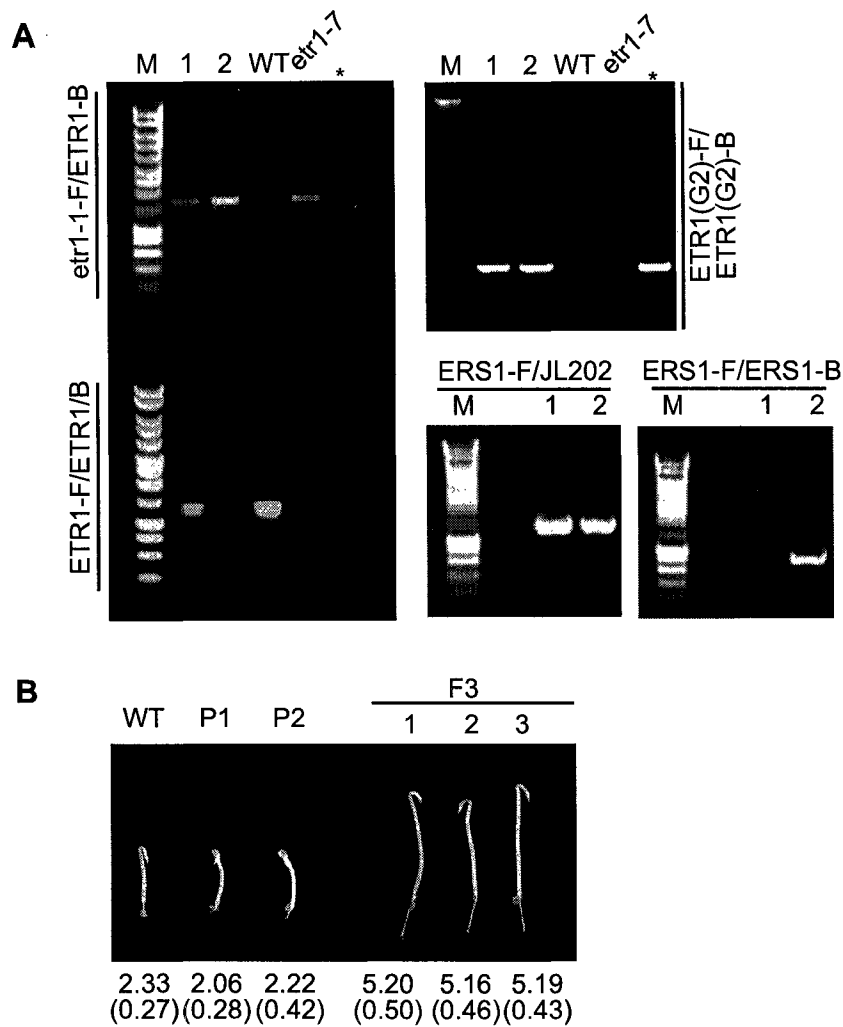

**Figure 21.** Genotyping and skotomorphological features of the progeny with partial ethylene insensitivity from the cross between *ers1-3* and a transgenic *etr1-7* line carrying the *ETR1(G2)* transgene. **A**, Genotyping of the selected "long hypocotyl" progeny. Genomic DNA was isolated from each plant line and used as the PCR template. The *etr1-7* mutation is identified by use of PCR with two primers *etr1-1-F* and *ETR1-B* (*etr1-1-F/ETR1-B*); the wild-type *ETR1* is identified with two primers *ETR1-F* and *ETR1-B* (*ETR1-F/ETR1-B*); the *ETR1(G2)* mutation is identified with the *ETR1(G2)-F* and *ETR1(G2)-B* primers [*ETR1(G2)-F/ETR1(G2)-B*]; the *ers1-3* mutation is identified with the *ERS1-F* and *JL202* primers (*ERS1-F/JL202*); and the wild-type *ERS1* is identified with the *ERS1-F* and *ERS1-B* primers (*ERS1-F/ERS1-B*). Two representative F3 progenies are indicated as 1 and 2. For PCR reaction of *etr1-1-F/ETR1-B*, asterisk indicates the transgenic *ETR1(G2)* line in the wild-type background. For reactions of *ETR1-F/ETR1-B* and *ETR1(G2)-F/ETR1(G2)-B*, asterisk indicates the homozygous *etr1-7* line carrying the *ETR1(G2)* transgene. M indicates the DNA size ladder. **B**, Effect of the *ETR1(G2)* mutation upon the triple response. Etiolated seedlings were grown for 3.5 d in the presence of  $10 \mu\text{L L}^{-1}$  ethylene. Mean hypocotyl lengths are given in millimeters with SD in parentheses. Three representative F3 seedlings with long hypocotyl are shown (F3). 1 and 2 are from two *etr1-7;ers1-3/+* transgenic lines carrying *ETR1(G2)*, 3 is from the *etr1-7/+;ers1-3* transgenic line carrying *ETR1(G2)*. For comparison, the wild-type (WT), *ers1-3* (P1), and *ETR1(G2);etr1-7* (P2) controls are shown.



hypocotyl” seedlings displayed a distinct growth phenotype with elongated hypocotyl and root in comparison with wild-type and their parent lines (Figure 21B). These results indicate that the histidine kinase activity of the ethylene receptor ETR1 may play a role in the establishment of ethylene responses.

### **A Complementary Approach to Analyze the Role of Histidine Kinase Activity in Ethylene Signaling**

Taking advantage of an existing *etr1-7* transgenic line, the cross described in the earlier section provided important but incomplete evidence supporting a role of the histidine kinase activity of ETR1 in ethylene signal transduction. To further resolve this essential question, I have been taking a complementary approach using the T-DNA insertion mutants *ers1-3* and *etr1-9*. Plants heterozygous for *ers1-3* and homozygous for *etr1-9* (*ers1-3/+;etr1-9*) were used for transformation because the *ers1;etr1* double loss-of-function mutants are sterile. Various *ETR1* mutant constructs (Figure 14) were introduced into this *ers1-3/+;etr1-9* mutant background and will be analyzed for their ability to rescue the double null mutant phenotype.

The approach described here has several major advantages over the previous one. First, it allows me to achieve the best likelihood of identifying the desired genotype. In theory, three out of 16 T<sub>2</sub> progenies will be homozygous for both *ers1-3* and *etr1-9*, and carry at least one copy of the transgene (or 1/16 of T<sub>2</sub> will be homozygous at all loci). In contrast, a much lower ratio for the desired genotype was expected from the cross (about 3/64 and 1/64, respectively). Second, it is easier and faster to identify the *ers1-3* and *etr1-9* mutations due to the ease of identifying T-DNA insertions, whereas the *etr1-7* mutant

only contains two single-nucleotide mutations and two rounds of PCR are required for identification. Third, the G2-box mutation in *ETR1(G2)* only abolishes the kinase activity of the receptor. The highly conserved phosphorylation sites within *ETR1(G2)*, including His-353 and Asp-659, could still be phosphorylated by other histidine kinases. By using various mutant versions of the *ETR1* transgene besides *ETR1(G2)*, I should also be able to gain more information on the role of histidine kinase activity in ethylene signaling. Detailed experimental strategy and design will be discussed in Chapter IV.

## DISCUSSION

In *Arabidopsis*, ethylene signaling is mediated by a small receptor family consisting of five members. Loss-of-function mutations have been isolated for all three members of the ethylene receptor subfamily 2 (*ETR2*, *ERS2* and *EIN4*), and for *ETR1* from subfamily 1 (Hua and Meyerowitz, 1998). In this study, two newly isolated T-DNA insertion mutants, *ers1-3* and *etr1-9*, were demonstrated to be loss-of-function mutant alleles of *ERS1* and *ETR1*, respectively. Both *ers1-3* and *etr1-9* single mutations have minor effects upon plant growth. However, in combination, the *ers1-3;etr1-9* double mutant seedlings displayed a strong constitutive ethylene response phenotype when grown in the dark. In addition, the double mutant plants showed severe growth defects when grown under the light. Thus, my data are consistent with ethylene receptors being negative regulators that function redundantly in ethylene signaling (Hua and Meyerowitz, 1998).

My results indicate that subfamily 1 receptors play a greater role in ethylene signaling than subfamily 2 receptors. Previous physiological analysis of the *etr1* loss-of-

function mutants suggested that ETR1 plays a greater role in ethylene signaling compared to receptor members from subfamily 2, because it was the only mutant that showed a phenotype as a single loss-of-function allele (Hua and Meyerowitz, 1998; Cancel and Larsen, 2002). Similar to the *etr1* mutant, the *ers1-3* loss-of-function mutant showed a small but consistent ethylene response phenotype, which is absent in the single loss-of-function mutants of the subfamily 2 members (Hua and Meyerowitz, 1998). An etiolated *ers1-3;etr1-9* double null mutant, which lacks the entire ethylene receptor subfamily 1, displays a more profound constitutive ethylene response phenotype than that observed in the *etr2;ein4;ers2* triple loss-of-function mutant, which lacks the entire subfamily 2 (Hua and Meyerowitz, 1998; Hall and Bleecker, 2003). On the other hand, both *ers1;etr1* and *etr2;ers2;ein4* mutant seedlings are still responsive to ethylene, indicating that receptors from subfamily 2 are capable of signaling independently. Together, these observations indicate that, despite functional overlap between these two subfamilies, subfamily 1 receptors play a predominant role in ethylene signaling when compared to subfamily 2 receptors. Additional recent work indicates that the deficiency in subfamily 1 receptors in the *ers1;etr1* double mutants can not be compensated simply by increased expression of subfamily 2 receptors (Wang et al., 2003). This result further supports the uniqueness of subfamily 1 receptors in ethylene signaling.

All five ethylene receptors have been demonstrated to interact with CTR1, a downstream Raf-like protein kinase (Clark et al., 1998; Cancel and Larsen, 2002; Gao et al., 2003). CTR1 is a negative regulator in ethylene signaling and loss-of-function mutations in *CTR1* result in constitutive ethylene responses (Kieber et al., 1993; Huang et al., 2003). Our recent data indicate that the soluble CTR1 is localized to the endoplasmic

reticulum (ER) and forms a CTR1-ethylene receptor signaling complex in *Arabidopsis* (Gao et al., 2003). Given that only subfamily 1 receptors possess a conserved and functional histidine kinase domain (Bleecker, 1999; Chang and Stadler, 2001; Schaller and Kieber, 2002), one could argue that the predominant contribution of subfamily 1 members to ethylene signaling may arise from their greater effectiveness at maintaining CTR1 in an active state due to a stronger interaction with CTR1 through the highly conserved histidine kinase domain or by use of the histidine kinase activity, when compared to other receptors from subfamily 2. The *ers1;etr1* double mutants display a stronger ethylene phenotype than does the *ctr1-2* loss-of-function mutant, suggesting the existence of a CTR1-independent ethylene signaling pathway potentially mediated by a CTR1-like protein(s) or other CTR1-parallel signaling components. Thus, an alternative explanation would be that this CTR1-independent ethylene pathway is mainly regulated by subfamily 1 receptors. Nevertheless, elucidation of the necessity of histidine kinase activity in ethylene signaling is the first step toward our understanding how subfamily 1 receptors achieve their greater role in ethylene signaling.

My results support a role for the histidine kinase activity of ETR1 in the establishment of ethylene responses. Progeny obtained from the cross between *ers1-3* and a homozygous *etr1-7* line containing the kinase-inactivated *ETR1(G2)* transgene exhibited partial ethylene insensitivity. To elicit ethylene responses in the presence of ethylene, the negative regulator CTR1 has to be inactivated. It has been demonstrated that CTR1 interacts with ethylene receptors via its amino-terminal region, which is suggested to regulate the enzymatic activity of CTR1 according to the Raf kinase model (Clark et al., 1998; Huang et al., 2003). In addition, the histidine kinase domain of subfamily 1

receptors is sufficient for the interaction with CTR1 (Clark et al., 1998; Gao et al., 2003). Given that CTR1 may form a stable signaling complex with ethylene receptors at the ER membrane (Gao et al., 2003), my results are indicative that the histidine kinase activity of subfamily 1 receptors may play a role in inactivation of CTR1 upon binding of ethylene by the receptor. Therefore, a receptor-CTR1 signaling model could be the following: In air, CTR1 is directly activated by ethylene receptors and forms a signaling complex with ethylene receptors at the ER membrane, and the activated CTR1 phosphorylates downstream targets to turn off ethylene signaling; in the presence of ethylene, binding of ethylene results in the activation of the histidine kinase activity of the subfamily 1 receptors, which in turn leads to the inactivation of CTR1 and releases the repression upon ethylene responses. In this study, I was unable to isolate the homozygous *ers1;etr1* lines carrying the *ETR1(G2)* transgene. A simple explanation would be that my selection was not saturated. Alternatively, *ETR1(G2)* may not fully rescue the double mutant phenotype. My previous study in the *etr1;etr2;ein4* triple mutant background indicates that the *ETR1(G2)* transgenic seedlings are slightly shorter than wild-type in air, and also display slightly increased ethylene sensitivity (Chapter II).

My results indicate that *ers1-2* is a hypomorphic rather than a null allele of *ERS1*. Northern-blot analysis indicated that, although there was a substantial reduction in message level, full-length *ERS1* transcripts were still detectable. The T-DNA insertion at the 5'-UTR (untranslated region) generates eight additional ATG start sites located upstream of the correct start codon in *ers1-2* (Wang et al., 2003). Based on the presence of these false ATG start sites, Wang et al. argued that *ers1-2* is a null allele (2003). However, there are two upstream ATGs in the 5'-UTR of the wild-type *ERS1* gene. Thus

the presence of upstream ATGs does not prevent correct transcription of the gene. In addition, the *ers1-3;etr1* double mutant displayed a stronger ethylene-response-like phenotype than the *ers1-2;etr1* mutant. Thus, *ers1-2* is not an appropriate line with which to address the role of the histidine kinase activity in ethylene signaling. Previously, Wang et al. (2003) made use of the *ers1-2;etr1* background to examine whether the histidine kinase activity is involved ethylene signaling. Based on the observation that a kinase-inactivated *ETR1* genomic clone rescued the *ers1-2;etr1* mutant phenotype, they concluded that the histidine kinase activity of ETR1 is not required for receptor signaling (Wang et al., 2003). However, the histidine kinase activity provided by the remaining ERS1 receptor in this *ers1-3;etr1* background might be sufficient for the receptor to elicit proper ethylene responses. In addition, my data demonstrate that the histidine kinase activity of ETR1 plays a role in the establishment of ethylene responses.

Bolting represents the transition from vegetative growth to flowering during plant development. The time of the initiation of bolting is crucial for the reproductive success of plants; therefore, plants have developed mechanisms to integrate both environmental and endogenous cues to regulate bolting time precisely (Mouradov et al., 2002; Simpson and Dean, 2002). Interestingly, the *ers1-3;etr1-9* plants did not bolt. This effect was partially phenocopied by treating the *ctr1-2* mutant plants with the ethylene biosynthesis precursor ACC. *ctr1-2* is a constitutive ethylene response mutant allele of *CTR1*, and thus already displays enhanced ethylene responses (Kieber et al., 1993). These results suggest that excessive ethylene may result in delays in bolting time. Interestingly, ethylene insensitive mutations also result in delays in bolting time (Ogawara et al., 2003). Together, these observations indicate that the amount of ethylene signal, which is transferred

though an ethylene signal transduction pathway, may be used by plants as an internal signal (switch) to control the transition from vegetative to reproductive growth. Ethylene insensitivity and constitutive ethylene responses represent two extremes of the ethylene condition. The *ctr1-2* plants were still capable of bolting when treated ACC, indicating that, ethylene, synthesized by the *ctr1-2* mutant with the supplied ACC, was not sufficient to induce ethylene responses to the maximum level. Alternatively, an additional factor or factors acting parallel to CTR1 in ethylene signaling might be regulated by the ethylene receptors so that in the absence of CTR1, ethylene receptors can still signal through the CTR1-independent pathway and induce ethylene responses upon perception of ethylene.

In summary, *ers1-3* and *etr1-9* are null alleles of *ERS1* and *ETR1*, respectively, whereas *ers1-2* is hypomorphic allele of *ERS1*. Results described in this chapter demonstrate that ethylene receptor subfamily 1 members (ETR1 and ERS1) play a predominant role in ethylene signaling. Genetic and physiological analyses suggest that the histidine kinase activity of ETR1 may play a role in the establishment of ethylene responses. Further characterization of the role of the histidine kinase activity in ethylene signaling, using the *ers1/+;etr1* background and various versions of the *ETR1* transgene, should continue to provide valuable insight into the mechanisms that control ethylene signaling in *Arabidopsis*.

## CHAPTER IV

### SUMMARY

### CONCLUSIONS

Although ethylene ( $\text{H}_2\text{C}=\text{CH}_2$ ) is a simple bi-carbon gaseous molecule, it is one of the most important plant hormones and plays a critical role during plant growth and development (Yang and Hoffman, 1984; Abeles et al., 1992; Bleecker and Kende, 2000; Schaller and Kieber, 2002). *Arabidopsis* contains a five-member receptor family that perceives the ethylene signal and mediates ethylene signal transduction (Chang et al., 1993; Hua et al., 1995; Hua et al., 1998; Sakai et al., 1998). The ethylene receptor family is further divided into two subfamilies based on phylogenetic analysis and some shared structural features: subfamily 1 consists of ETR1 and ERS1, which possess a functional histidine kinase domain (Chang et al., 1993; Hua et al., 1995); subfamily 2 includes ETR2, ERS2, and EIN4, which have a diverged histidine kinase domain that is predicted to not be functional (Hua et al., 1998; Sakai et al., 1998). Previous work demonstrates that three hydrophobic segments at the amino-terminal half of the receptor are involved in perception of the ethylene hormone and membrane localization of the receptor (Schaller and Bleecker, 1995; Rodriguez et al., 1999; Chen et al., 2002). In contrast, little is known about how the ethylene stimulus, once perceived by the receptor, is transduced from the ethylene receptor to the downstream signaling components.

The hypothesis, which has been examined extensively in this dissertation, is that



ethylene receptors transduce the ethylene signal via the proposed signal output region that includes the histidine kinase domain and the receiver domain. Given that ETR1 is the best characterized ethylene receptor, research presented in this dissertation was focused on analysis of signal output by the ethylene receptor ETR1 from *Arabidopsis*. For this purpose, I used a mutant-based approach to determine the specific region of ETR1 that is required for the signal output and the potential mechanism by which signal output is regulated. The study described in Chapter II was performed in the *etr1;etr2;ein4* triple loss-of-function mutant background and elucidates that the histidine kinase domain of ETR1 is required for repression of ethylene responses in air. Data obtained from the study of *ers1;etr1* double mutants indicate that the histidine kinase activity of ETR1 plays a role in the establishment of ethylene responses (Chapter III). Genetic and physiological analyses from this dissertation support the model shown in Figure 22, whereby the ethylene receptor ETR1 activates CTR1 in the absence of ethylene, as a result of protein-protein interaction via its kinase domain; in the presence of ethylene, phosphorylation of ETR1 by its kinase activity de-activates CTR1, which leads to release of the repression and induction of ethylene responses.

To determine whether the proposed signal output region is required for ethylene signaling, four loss-of-function mutant alleles of *ETR1* (*etr1-5*, *etr1-6*, *etr1-7*, and *etr1-8*) were initially chosen for study because they contain point mutations predicted to result in premature truncations in different regions of the receptor (Hua and Meyerowitz, 1998). No full-length or truncated protein was detected for any of these *etr1* mutants, indicating that the loss-of-function arises from an absence of the receptor but not from a truncated receptor incapable of signaling. On the other hand, transcripts were detected for each of

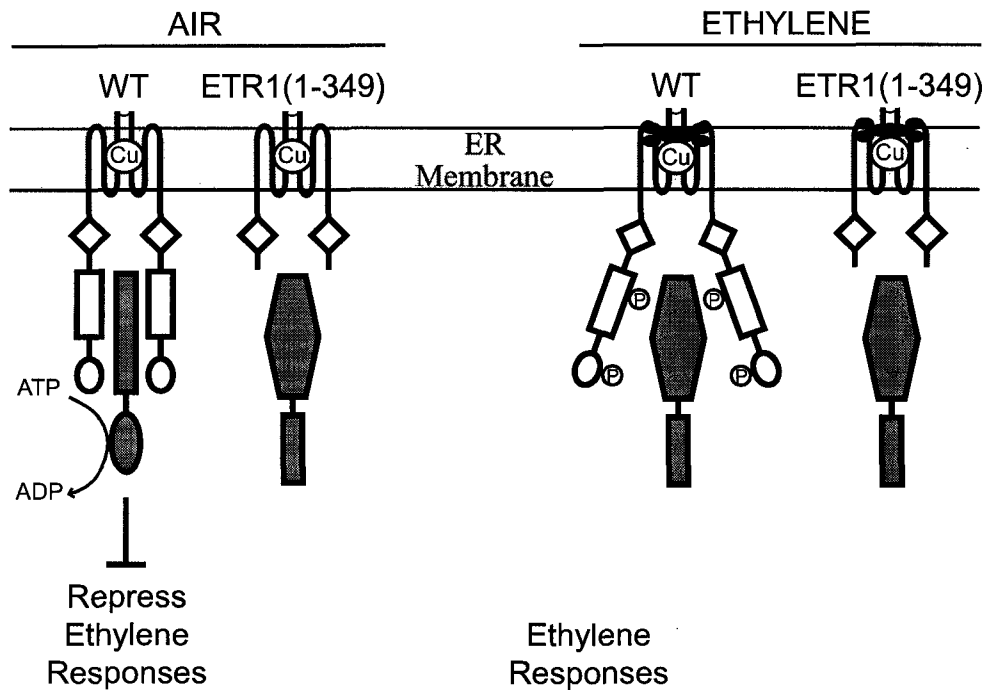

**Figure 22.** A model of ethylene signaling by the ethylene receptor ETR1 via regulation of CTR1 activity. The ethylene receptor ETR1 forms a homodimer via the disulfide bond linkage. Each homodimer contains one ethylene-binding site. A metal ion cofactor, copper (Cu), is required for ethylene binding. In air, ETR1 actively represses ethylene responses, presumably through interaction with CTR1 (shown in grey). Lacking His kinase domain and receiver domain, the truncated ETR1(1-349) receptor cannot activate CTR1, which in turn results in release of repression. In the presence of ethylene, the histidine kinase activity of ETR1 is switched on, and as a result, CTR1 is inactivated. Inactivation of CTR1 by ETR1 results in relieving repression of ethylene responses.

the *etr1* loss-of-function mutants, indicating that the lack of detectable protein in the *etr1* mutants is due to both transcriptional and post-transcriptional regulatory mechanisms.

Since the *etr1* loss-of-function mutants can not be used to directly assess the role of the proposed signal output domain, a different approach was undertaken using the *etr1-6;etr2-3;ein4-4* triple loss-of-function mutant line as a genetic background to characterize signal output by ETR1. The ability of mutant versions of ETR1 to rescue the constitutive response phenotype of this triple loss-of-function mutant line was examined. The histidine kinase domain of ETR1 is required for repression of ethylene responses. The truncated ETR1(1-349) receptor lacking both histidine kinase and receiver domains failed to rescue the triple mutant phenotype, whereas the truncated ETR1(1-603) receptor lacking only the receiver domain was able to confer sufficient repression upon ethylene responses and the transgenic seedlings displayed wild-type-like growth in air. Previous studies demonstrated that ETR1 interacts with CTR1 via its kinase domain (Clark et al., 1998; Gao et al., 2003). In addition, this interaction is crucial for CTR1 to maintain its function as a negative regulator in ethylene signaling (Gao et al., 2003; Huang et al., 2003). Thus, ETR1 exerts its role of repressing ethylene responses in air by activation of CTR1 via its histidine kinase domain.

The *etr1;etr2;ein4* triple null mutant lacks all the ethylene receptor members that possess a receiver domain. Therefore, it is feasible to assess the role of the receiver domain of ETR1 in ethylene signaling by using this triple mutant background. Although the receiver domain is dispensable for the role of the receptor in air, the transgenic seedlings with the truncated ETR1(1-603) receptor exhibited hypersensitivity to ethylene,

indicating a regulatory role of the receiver domain in the establishment of ethylene responses.

To continue the research described in Chapter II, an independent mutant-based approach was undertaken to assess the role of histidine kinase activity in ethylene signaling. Given that subfamily 1 members (*ETR1* and *ERS1*) are the only ethylene receptors with a conserved and functional histidine kinase domain (Chang et al., 1993; Hua et al., 1995), *ers1* and *etr1* single loss-of-function mutants were isolated and the *ers1;etr1* double mutants were generated by cross pollination. Loss of the entire ethylene receptor subfamily 1 results in a dramatic growth phenotype: the *ers1;etr1* mutant etiolated seedlings exhibit a constitutive ethylene response phenotype, which is more profound than that observed in the *etr1;etr2;ein4;ers2* quadruple loss-of-function mutant reported previously (Hua and Meyerowitz, 1998); the mutant green plants were dwarfed with small and epinastic leaves in the air and died without bolting. In conjunction with the observation that *ETR1*-promoter-driven cDNAs of *ETR1* and *ERS1*, but not *ETR2*, *EIN4*, and *ERS2*, rescue the *ers1-2;etr1-7* double mutant phenotype (Wang et al., 2003), these results indicate that subfamily 1 receptors play a greater role in ethylene signaling compared to subfamily 2 receptors. Genetic and physiological analyses demonstrate that the histidine kinase activity is required for the establishment of ethylene responses, whereby a decrease in kinase activity resulted in partial ethylene insensitivity. On the other hand, the histidine kinase activity of *ETR1* may also play a role in the repression of ethylene responses in air. These results are consistent with and further explain the predominant role of subfamily 1 in ethylene signal transduction. In addition, my data

indicate that ethylene delays bolting, an ethylene response that might be primarily mediated by the subfamily 1 members.

In conclusion, the results described in this dissertation have established the importance of the proposed signal output region of ETR1 in ethylene signaling. The histidine kinase domain of the receptor is required for repression of ethylene responses. The receiver domain is not required for repression of ethylene responses, but may play a regulatory role in the establishment of ethylene responses. Further study in the *ers1;etr1* double null mutant background demonstrates that subfamily 1 members play a predominant role in ethylene signaling. Genetic and physiological analyses indicate that the histidine kinase activity of ETR1 plays a role in the establishment of ethylene responses and may also play a role in the repression of ethylene responses. Further characterization of the role of the histidine kinase activity in ethylene signaling, using the *ers1/+;etr1* background and various versions of the *ETR1* transgene, should continue to provide valuable insight into the mechanisms that control ethylene signaling in *Arabidopsis*.

## FUTURE DIRECTIONS

### **Elucidation of Molecular Mechanism by which the Receiver Domain Functions in Ethylene Signaling**

Results from Chapter II indicate that the receiver domain of the ethylene receptor ETR1 may play a regulatory role in the establishment of ethylene responses. The receiver domain, which is originally derived from the bacterial two-component signaling system, contains a highly conserved phosphorylation site (aspartate residue located at position

659). To investigate whether phosphorylation of the receiver domain at Asp-659 is crucial for its function in ethylene signaling, a new site-directed *ETR1* mutant construct will be generated: the *ETR1(D659A)* mutation codes for a conversion of Asp-659 to Ala, representing the non-phosphorylated form of the receiver domain. The *ETR1(D659A)* transgene will be transformed into the *etr2;etr2;ein4* triple loss-of-function mutant line, and its ability to rescue the triple mutant phenotype will be examined. If *ETR1(D659A)* is capable of fully restoring ethylene responsiveness to the triple mutant, phosphorylation at Asp-659 is not essential for the receiver domain to confer its regulatory role in the establishment of ethylene responses. If the transgenic lines display increased ethylene sensitivity as observed previously in the *ETR1(1-603)* transgenic lines, then phosphorylation at Asp-659 is likely to be physiologically significant.

In the two-component signaling system, the response regulator, which contains a receiver domain, serves as an intermediate signaling component whereby it receives a phosphate group from the histidine residue of an upstream element and then passes the phosphate group to a downstream component (Stock et al., 2000; Urao et al., 2000). If phosphorylation at the Asp-659 residue of the receiver domain is required for ethylene signaling, the next important question will be whether the receiver domain of *ETR1* functions in the same way as described in the two-component system or whether phosphorylation at the Asp-659 residue may induce conformational changes of the receiver domain and thereby change its signaling state. To address this question, another *ETR1* mutant construct will be generated: the *ETR1(D659E)* mutation codes for a conversion of Asp-659 to glutamate, mimicking the phosphorylated form with regard to the negative charge provided by the phosphate group. The *ETR1(D659E)* construct will

be transformed into the *etr1;etr2;ein4* triple loss-of-function mutant background to assess its ability to restore ethylene responsiveness to the triple mutant. This proposed work will elucidate by which mechanism the receiver domain of ETR1 functions in ethylene signaling.

### **Further Analysis of the Role of Histidine Kinase Activity in Ethylene Signaling**

To continue the analysis of the cross between *ers1-3* and the homozygous *etr1-7* line containing the *ETR1(G2)* transgene, a new approach will be undertaken to saturate the selection for progenies with the desired genotype. For this purpose, five hundred T<sub>2</sub> seeds will be grown in the presence of 10  $\mu\text{L L}^{-1}$  ethylene. After 4-d growth in the dark, hypocotyl length of individual seedlings will be measured. A number of seedlings vs. hypocotyl length plot will be generated and compared to that of wild-type and the two parent lines for this cross. For genotyping, the ten seedlings with longest hypocotyl, the ten seedlings with shortest hypocotyl, and another ten with medium length will be selected. This research will increase the likelihood of identifying the homozygous progeny with the desired genotype. It will also provide direct information of how the *ETR1(G2)* transgene affects ethylene signaling in the transgenic plants with regard to hypocotyl elongation.

The cross between *ers1-3* and the homozygous *etr1-7* line containing the *ETR1(G2)* transgene provided us limited information about the role of the histidine kinase activity of ETR1 in ethylene signaling. The G2-box mutation only eliminates the kinase activity of ETR1. It is possible that the kinase-inactivated ETR1(G2) receptor may still be phosphorylated at the conserved His-353 and Asp-659 residues by other histidine

kinases. Our previous study in a yeast system demonstrates that ETR1 possesses histidine kinase activity (Gamble et al., 1998). However, no direct evidence supports its function as a histidine kinase *in planta*. To further clarify the role of the kinase activity of ETR1 in ethylene signaling, I will continue to examine the ability of individual ETR1(H), ETR1(HG2), ETR1(HG2D), and ETR1(G2) mutant receptors to rescue the *ers1-3;etr1-9* double mutant phenotype. Results obtained from this experiment will demonstrate whether the ethylene receptor ETR1 functions as a histidine kinase in *Arabidopsis* and will also further confirm whether the histidine kinase activity of ETR1 plays a role in ethylene signaling.

The histidine kinase domain and the receiver domain of ETR1 are evolutionarily related to signaling elements originally identified in the two-component systems of bacteria, which have also been demonstrated to exist in eukaryotic species including plants and fungi (Parkinson, 1993; Schaller, 2000). In addition to the prevailing receptor-CTR1 model for ethylene signaling where ethylene receptors interact with CTR1 and directly regulate its signaling, phosphorylation of the receptor may provide an alternative way to regulate the signaling indirectly, potentially via the His-to-Asp phosphorelay mechanism (Stock et al., 2000). To determine whether phosphorylation can directly affect CTR1 signaling or whether it can only affect it indirectly, several additional mutant versions of the *ETR1* transgene will be generated, including *ETR1(H353E)*, *ETR1(D659E)*, and *ETR1(D659A)*. These constructs will then be transformed into the *ers1-3/+;etr1-9* background and assessed for their ability to rescue the *ers1-3;etr1-9* double mutant phenotype. ETR1(H353E) mimics a constitutively phosphorylated receptor with regard to the negative charge. If ETR1(H353E) is able to rescue the double



mutant phenotype, but ETR1(H353Q) fails in rescuing, I can then conclude that conformational changes induced by autophosphorylation at the histidine residue by ETR1 affect the activity of CTR1, and as a direct output, the ethylene signaling is changed. On the other hand, if neither ETR1(H353Q) nor ETR1(H353E) mutant receptors can rescue the double mutant, it is suggestive that ETR1 may regulate ethylene signaling using a phosphorelay mechanism, which requires autophosphorylation at His-353 by its enzymatic activity. Using the same experimental strategy, similar questions in phosphorylation at the aspartate residue within the receiver domain of ETR1 can be addressed using *ETR1(D659A)* and *ETR1(D659E)*.

#### **Large-Scale Screens for Signaling Targets of ETR1 by Microarray Analysis**

A complete understanding of the molecular basis of how ETR1 regulates ethylene signaling through its histidine kinase activity required the identification of the authentic *in vivo* targets of ETR1. For this purpose, DNA microarray analysis will be conducted using two sets of probes derived from mRNAs isolated from the homozygous *ers1-3;etr1-9* seedlings carrying the kinase-inactivated *ETR1(G2)* transgene and the homozygous *ers1-3;etr1-9* seedlings carrying the wild-type *ETR1-FL* transgene. Seedlings will be grown in the presence of ethylene prior to RNA isolation. A subset of genes which are induced or repressed in the *ETR1-FL* line but remain unchanged in the *ETR1(G2)* line will be fished out. They represent genes potentially regulated directly by ETR1 through its kinase activity. With identification of these kinase-specific genes, a better picture of the histidine kinase-dependent ethylene signaling may be achieved.

Research described in this dissertation generated a number of data and solved some puzzles but raised even more questions. Thus as I had anticipated, my research is open-ended. Nonetheless, this work undoubtedly lends us insight into the relationship between the action of the ethylene receptor ETR1 and its kinase activity, and opens up new opportunities for future work. In addition, due to the agronomic importance of the plant hormone ethylene, it is foreseen that the research presented in this dissertation of ethylene signal transduction in *Arabidopsis* will be beneficial for agriculture.

## LIST OF REFERENCES

- Abeles, F.B., Morgan, P.W., and Saltveit, J., M. E.** (1992). Ethylene in plant biology. (San Diego: Academic Press).
- Alonso, J.M., Hirayama, T., Roman, G., Nourizadeh, S., and Ecker, J.R.** (1999). EIN2, a bifunctional transducer of ethylene and stress responses in *Arabidopsis*. *Science* **284**, 2148-2152.
- Alonso, J.M., Stepanova, A.N., Leisse, T.J., Kim, C.J., Chen, H., Shinn, P., Stevenson, D.K., Zimmerman, J., Barajas, P., Cheuk, R., Gadrinab, C., Heller, C., Jeske, A., Koesema, E., Meyers, C.C., Parker, H., Prednis, L., Ansari, Y., Choy, N., Deen, H., Geralt, M., Hazari, N., Hom, E., Karnes, M., Mulholland, C., Ndubaku, R., Schmidt, I., Guzman, P., Aguilar-Henonin, L., Schmid, M., Weigel, D., Carter, D.E., Marchand, T., Risseeuw, E., Brogden, D., Zeko, A., Crosby, W.L., Berry, C.C., and Ecker, J.R.** (2003). Genome-wide insertional mutagenesis of *Arabidopsis thaliana*. *Science* **301**, 653-657.
- Aravind, L., and Ponting, C.P.** (1997). The GAF domain: an evolutionary link between diverse phototransducing proteins. *Trends Biochem. Sci.* **22**, 458-459.
- Aronel, V., Lemieux, B., Hwang, I., Gibson, S., Goodman, H.M., and Somerville, C.R.** (1992). Map-based cloning of a gene controlling omega-3 fatty acid desaturation in *Arabidopsis*. *Science* **258**, 1353-1355.
- Berard, J., Luo, H., Chen, H., Mukuna, M., Bradley, W.E., and Wu, J.** (1997). Abnormal regulation of retinoic acid receptor beta2 expression and compromised allograft rejection in transgenic mice expressing antisense sequences to retinoic acid receptor beta1 and beta3. *J. Immunol.* **159**, 2586-2598.
- Bilwes, A.M., Alex, L.A., Crane, B.R., and Simon, M.I.** (1999). Structure of CheA, a signal-transducing histidine kinase. *Cell* **96**, 131-141.
- Bleecker, A.B.** (1999). Ethylene perception and signaling: an evolutionary perspective. *Trends Plant Sci.* **4**, 269-274.
- Bleecker, A.B., and Kende, H.** (2000). Ethylene: a gaseous signal molecule in plants. *Annu. Rev. Cell. Dev. Biol.* **16**, 1-18.
- Bleecker, A.B., Estelle, M.A., Somerville, C., and Kende, H.** (1988). Insensitivity to ethylene conferred by a dominant mutation in *Arabidopsis thaliana*. *Science* **241**, 1086-1089.

- Botella, J.R., Arteca, R.N., and Frangos, J.A.** (1995). A mechanical strain-induced 1-aminocyclopropane-1-carboxylic acid synthase gene. *Proc. Natl. Acad. Sci. USA* **92**, 1595-1598.
- Budziszewski, G.J., Lewis, S.P., Glover, L.W., Reineke, J., Jones, G., Ziemnik, L.S., Lonowski, J., Nyfeler, B., Aux, G., Zhou, Q., McElver, J., Patton, D.A., Martienssen, R., Grossniklaus, U., Ma, H., Law, M., and Levin, J.Z.** (2001). *Arabidopsis* genes essential for seedling viability: isolation of insertional mutants and molecular cloning. *Genetics* **159**, 1765-1778.
- Burg, S.P., and Burg, E.A.** (1967). Molecular requirement for the biological activity of ethylene. *Plant Physiol.* **42**, 144-152.
- Cancel, J.D., and Larsen, P.B.** (2002). Loss-of-function mutations in the ethylene receptor ETR1 cause enhanced sensitivity and exaggerated response to ethylene in *Arabidopsis*. *Plant Physiol.* **129**, 1557-1567.
- Carpenter, C.D., and Simon A.E.** (1998). Preparation of RNA. In Martinez-Zapater, J. M., Salinas, J., eds, *Methods in Molecular Biology, Vol 82: Arabidopsis Protocols*. Human Press, Totowa, NJ, pp 85-89.
- Chang, C., and Stadler, R.** (2001). Ethylene hormone receptor action in *Arabidopsis*. *Bioessays* **23**, 619-627.
- Chang, C., Kwok, S.F., Bleecker, A.B., and Meyerowitz, E.M.** (1993). *Arabidopsis* ethylene-response gene ETR1: similarity of product to two-component regulators. *Science* **262**, 539-544.
- Chao, Q., Rothenberg, M., Solano, R., Roman, G., Terzaghi, W., and Ecker, J.R.** (1997). Activation of the ethylene gas response pathway in *Arabidopsis* by the nuclear protein ETHYLENE-INSENSITIVE3 and related proteins. *Cell* **89**, 1133-1144.
- Chen, Q.G., and Bleecker, A.B.** (1995). Analysis of ethylene signal-transduction kinetics associated with seedling-growth response and chitinase induction in wild-type and mutant *Arabidopsis*. *Plant Physiol.* **108**, 597-607.
- Chen, Y.F., Randlett, M.D., Findell, J.L., and Schaller, G.E.** (2002). Localization of the ethylene receptor ETR1 to the endoplasmic reticulum of *Arabidopsis*. *J. Biol. Chem.* **277**, 19861-19866.
- Clark, K.L., Larsen, P.B., Wang, X., and Chang, C.** (1998). Association of the *Arabidopsis* CTR1 Raf-like kinase with the ETR1 and ERS ethylene receptors. *Proc. Natl. Acad. Sci. USA* **95**, 5401-5406.

- Clark, S.E., Williams, R.W., and Meyerowitz, E.M.** (1997). The CLAVATA1 gene encodes a putative receptor kinase that controls shoot and floral meristem size in *Arabidopsis*. *Cell* **89**, 575-585.
- Clough, S.J., and Bent, A.F.** (1998). Floral dip: a simplified method for *Agrobacterium*-mediated transformation of *Arabidopsis thaliana*. *Plant J.* **16**, 735-743.
- Cousins, H.H.** (1910). Agriculture experiments. Citrus. Ann. Rep. Dep. Agric., Jamaica, 7.
- Feldmann KA, M.M., Christianson ML, and Quatrano RS.** (1989). A dwarf mutant of *Arabidopsis* generated by T-DNA insertion mutagenesis. *Science* **243**, 1351-1354.
- Fujimoto, S.Y., Ohta, M., Usui, A., Shinshi, H., and Ohme-Takagi, M.** (2000). *Arabidopsis* ethylene-responsive element binding factors act as transcriptional activators or repressors of GCC box-mediated gene expression. *Plant Cell* **12**, 393-404.
- Gamble, R.L., Coonfield, M.L., and Schaller, G.E.** (1998). Histidine kinase activity of the ETR1 ethylene receptor from *Arabidopsis*. *Proc. Natl. Acad. Sci. USA* **95**, 7825-7829.
- Gamble, R.L., Qu, X., and Schaller, G.E.** (2002). Mutational analysis of the ethylene receptor ETR1. Role of the histidine kinase domain in dominant ethylene insensitivity. *Plant Physiol.* **128**, 1428-1438.
- Gane, R.** (1934). Production of ethylene by some ripening fruit. *Nature* **134**, 1008.
- Gao, Z., Chen, Y.F., Randlett, M.D., Zhao, X.C., Findell, J.L., Kieber, J.J., and Schaller, G.E.** (2003). Localization of the Raf-like kinase CTR1 to the endoplasmic reticulum of *Arabidopsis* through participation in ethylene receptor signaling complexes. *J. Biol. Chem.* **278**, 34725-34732.
- Giraudat, J., Hauge, B.M., Valon, C., Smalle, J., Parcy, F., and Goodman, H.M.** (1992). Isolation of the *Arabidopsis* ABI3 gene by positional cloning. *Plant Cell* **4**, 1251-1261.
- Guzman, P., and Ecker, J.R.** (1990). Exploiting the triple response of *Arabidopsis* to identify ethylene-related mutants. *Plant Cell* **2**, 513-523.
- Hall, A.E., and Bleeker, A.B.** (2003). Analysis of combinatorial loss-of-function mutants in the *Arabidopsis* ethylene receptors reveals that the *ers1;etr1* double mutant has severe developmental defects that are EIN2 dependent. *Plant Cell* **15**, 2032-2041.

- Hall, A.E., Chen, Q.G., Findell, J.L., Schaller, G.E., and Bleecker, A.B.** (1999). The relationship between ethylene binding and dominant insensitivity conferred by mutant forms of the ETR1 ethylene receptor. *Plant Physiol.* **121**, 291-300.
- Hall, A.E., Findell, J.L., Schaller, G.E., Sisler, E.C., and Bleecker, A.B.** (2000). Ethylene perception by the ERS1 protein in *Arabidopsis*. *Plant Physiol.* **123**, 1449-1458.
- Hua, J., and Meyerowitz, E.M.** (1998). Ethylene responses are negatively regulated by a receptor gene family in *Arabidopsis thaliana*. *Cell* **94**, 261-271.
- Hua, J., Chang, C., Sun, Q., and Meyerowitz, E.M.** (1995). Ethylene insensitivity conferred by *Arabidopsis* ERS gene. *Science* **269**, 1712-1714.
- Hua, J., Sakai, H., Nourizadeh, S., Chen, Q.G., Bleecker, A.B., Ecker, J.R., and Meyerowitz, E.M.** (1998). EIN4 and ERS2 are members of the putative ethylene receptor gene family in *Arabidopsis*. *Plant Cell* **10**, 1321-1332.
- Huang, Y., Li, H., Hutchison, C.E., Laskey, J., and Kieber, J.J.** (2003). Biochemical and functional analysis of CTR1, a protein kinase that negatively regulates ethylene signaling in *Arabidopsis*. *Plant J.* **33**, 221-233.
- Hwang, I., and Sheen, J.** (2001). Two-component circuitry in *Arabidopsis* cytokinin signal transduction. *Nature* **413**, 383-389.
- Hwang, I., Chen, H.C., and Sheen, J.** (2002). Two-component signal transduction pathways in *Arabidopsis*. *Plant Physiol.* **129**, 500-515.
- Johnson, P.R., and Ecker, J.R.** (1998). The ethylene gas signal transduction pathway: a molecular perspective. *Annu. Rev. Genet.* **32**, 227-254.
- Kende, H.** (1993). Ethylene biosynthesis. *Annu. Rev. Plant Physiol. Plant Mol. Biol.* **44**, 283-307.
- Kende, H., and Zeevaart, J.** (1997). The five "classical" plant hormones. *Plant Cell* **9**, 1197-1210.
- Kieber, J.J., and Ecker, J.R.** (1993). Ethylene gas: it's not just for ripening any more! *Trends Genet.* **9**, 356-362.
- Kieber, J.J., Rothenberg, M., Roman, G., Feldmann, K.A., and Ecker, J.R.** (1993). CTR1, a negative regulator of the ethylene response pathway in *Arabidopsis*, encodes a member of the raf family of protein kinases. *Cell* **72**, 427-441.

- Kim, H., Snesrud, E.C., Haas, B., Cheung, F., Town, C.D., and Quackenbush, J.** (2003). Gene expression analyses of *Arabidopsis* chromosome 2 using a genomic DNA amplicon microarray. *Genome Res.* **13**, 327-340.
- Krall, L., and Reed, J.W.** (2000). The histidine kinase-related domain participates in phytochrome B function but is dispensable. *Proc. Natl. Acad. Sci. USA* **97**, 8169-8174.
- Laemmli, U.K.** (1970). Cleavage of structural proteins during the assembly of the head of bacteriophage T4. *Nature* **227**, 680-685.
- Lehman, A., Black, R., and Ecker, J.R.** (1996). HOOKLESS1, an ethylene response gene, is required for differential cell elongation in the *Arabidopsis* hypocotyl. *Cell* **85**, 183-194.
- Li, J., and Chory, J.** (1997). A putative leucine-rich repeat receptor kinase involved in brassinosteroid signal transduction. *Cell* **90**, 929-938.
- Liang, X., Shen, N.F., and Theologis, A.** (1996). Li(+)-regulated 1-aminocyclopropane-1-carboxylate synthase gene expression in *Arabidopsis thaliana*. *Plant J.* **10**, 1027-1036.
- Lohrmann, J., and Harter, K.** (2002). Plant two-component signaling systems and the role of response regulators. *Plant Physiol.* **128**, 363-369.
- Lowry, O.H., Rosebrough, N.J., Farr, A.L., and Randall, R.J.** (1951). Protein measurement with the Folin phenol reagent. *J. Biol. Chem.* **193**, 265-275.
- Maeda, T., Wurgler-Murphy, S.M., and Saito, H.** (1994). A two-component system that regulates an osmosensing MAP kinase cascade in yeast. *Nature* **369**, 242-245.
- Maeda, T., Takekawa, M., and Saito, H.** (1995). Activation of yeast PBS2 MAPKK by MAPKKKs or by binding of an SH3-containing osmosensor. *Science* **269**, 554-558.
- Matsushita, T., Mochizuki, N., and Nagatani, A.** (2003). Dimers of the N-terminal domain of phytochrome B are functional in the nucleus. *Nature* **424**, 571-574.
- Meyerowitz, E., and Pruitt, R.** (1985). *Arabidopsis-thaliana* and plant molecular-genetics. *Science* **229**, 1214-1218.
- Meyerowitz, E.M.** (2001). Prehistory and History of *Arabidopsis* Research. *Plant Physiol.* **125**, 15-19.
- Meyerowitz, E.M.** (2002). Plants Compared to Animals: The Broadest Comparative Study of Development. *Science* **295**, 1482-1485.

- Minkoff, R., Bales, E.S., Kerr, C.A., and Struss, W.E.** (1999). Antisense oligonucleotide blockade of connexin expression during embryonic bone formation: evidence of functional compensation within a multigene family. *Dev. Genet.* **24**, 43-56.
- Miyazaki, J.H., and Yang, S.F.** (1987). The methionine salvage pathway in relation to ethylene and polyamine biosynthesis. *Physiol. Plant.* **69**, 366-370.
- Mizuno, T.** (1998). His-Asp phosphotransfer signal transduction. *J. Biochem. (Tokyo)* **123**, 555-563.
- Mouradov, A., Cremer, F., and Coupland, G.** (2002). Control of flowering time: interacting pathways as a basis for diversity. *Plant Cell* **14 Suppl**, S111-130.
- Mulligan, G.J., Wong, J., and Jacks, T.** (1998). p130 is dispensable in peripheral T lymphocytes: evidence for functional compensation by p107 and pRB. *Mol. Cell. Biol.* **18**, 206-220.
- Neljubow, D.** (1901). Ueber die horizontale Nutation der Stengel von *Pisum sativum* und einiger anderer. *Pflanzen Beih. Bot. Zentralbl* **10**, 128-239.
- Ogawara, T., Higashi, K., Kamada, H., and Ezura, H.** (2003). Ethylene advances the transition from vegetative growth to flowering in *Arabidopsis thaliana*. *J. Plant Physiol.* **160**, 1335-1340.
- Ohme-Takagi, M., and Shinshi, H.** (1995). Ethylene-inducible DNA binding proteins that interact with an ethylene-responsive element. *Plant Cell* **7**, 173-182.
- O'Neill, C.M., and Mathias, R.J.** (1993). Regeneration of plants from protoplasts of *Arabidopsis thaliana* L. cv. *Columbia* (C24) via direct embryogenesis. *J. Exp. Bot.* **44**, 1579-1585.
- Ota, I.M., and Varshavsky, A.** (1993). A yeast protein similar to bacterial two-component regulators. *Science* **262**, 566-569.
- Parkinson, J.S.** (1993). Signal transduction schemes of bacteria. *Cell* **73**, 857-871.
- Posas, F., Wurgler-Murphy, S.M., Maeda, T., Witten, E.A., Thai, T.C., and Saito, H.** (1996). Yeast HOG1 MAP kinase cascade is regulated by a multistep phosphorelay mechanism in the SLN1-YPD1-SSK1 "two-component" osmosensor. *Cell* **86**, 865-875.
- Rhee, S.Y., Beavis, W., Berardini, T.Z., Chen, G., Dixon, D., Doyle, A., Garcia-Hernandez, M., Huala, E., Lander, G., Montoya, M., Miller, N., Mueller, L.A., Mundodi, S., Reiser, L., Tacklind, J., Weems, D.C., Wu, Y., Xu, I., Yoo, D., Yoon, J., and Zhang, P.** (2003). The *Arabidopsis* Information Resource



- (TAIR): a model organism database providing a centralized, curated gateway to Arabidopsis biology, research materials and community. Nucl. Acids. Res. **31**, 224-228.
- Riechmann, J.L., and Meyerowitz, E.M.** (1998). The AP2/EREBP family of plant transcription factors. Biol. Chem. **379**, 633-646.
- Rodriguez, F.I., Esch, J.J., Hall, A.E., Binder, B.M., Schaller, G.E., and Bleecker, A.B.** (1999). A copper cofactor for the ethylene receptor ETR1 from *Arabidopsis*. Science **283**, 996-998.
- Roman, G., Lubarsky, B., Kieber, J.J., Rothenberg, M., and Ecker, J.R.** (1995). Genetic analysis of ethylene signal transduction in *Arabidopsis thaliana*: five novel mutant loci integrated into a stress response pathway. Genetics **139**, 1393-1409.
- Sakai, H., Hua, J., Chen, Q.G., Chang, C., Medrano, L.J., Bleecker, A.B., and Meyerowitz, E.M.** (1998). *ETR2* is an *ETR1*-like gene involved in ethylene signaling in *Arabidopsis*. Proc. Natl. Acad. Sci. USA **95**, 5812-5817.
- Schaller, G.E.** (2000). Histidine kinases and the role of two-component systems in plants. Adv. Bot. Res. **32**, 109-148.
- Schaller, G.E., and Bleecker, A.B.** (1995). Ethylene-binding sites generated in yeast expressing the *Arabidopsis ETR1* gene. Science **270**, 1809-1811.
- Schaller, G.E., and DeWitt, N.D.** (1995). Analysis of the H(+)-ATPase and other proteins of the *Arabidopsis* plasma membrane. Methods Cell Biol. **50**, 129-148.
- Schaller, G.E., and Kieber, J.J.** (2002). Ethylene. In *The Arabidopsis Book*, C. Somerville, Meyerowitz, E. M., ed (Rockville, MD: American Society of Plant Biologists).
- Schaller, G.E., Ladd, A.N., Lanahan, M.B., Spanbauer, J.M., and Bleecker, A.B.** (1995). The ethylene response mediator ETR1 from *Arabidopsis* forms a disulfide-linked dimer. J. Biol. Chem. **270**, 12526-12530.
- Sheen, J.** (2002). Phosphorelay and transcription control in cytokinin signal transduction. Science **296**, 1650-1652.
- Simpson, G.G., and Dean, C.** (2002). *Arabidopsis*, the Rosetta stone of flowering time? Science **296**, 285-289.
- Solano, R., Stepanova, A., Chao, Q., and Ecker, J.R.** (1998). Nuclear events in ethylene signaling: a transcriptional cascade mediated by ETHYLENE-INSENSITIVE3 and ETHYLENE-RESPONSE-FACTOR1. Genes. Dev. **12**, 3703-3714.

- Stock, A.M., and Mowbray, S.L.** (1995). Bacterial chemotaxis: a field in motion. *Curr. Opin. Struct. Biol.* **5**, 744-751.
- Stock, A.M., Robinson, V.L., and Goudreau, P.N.** (2000). Two-component signal transduction. *Annu. Rev. Biochem.* **69**, 183-215.
- Swanson, R.V., Alex, L.A., and Simon, M.I.** (1994). Histidine and aspartate phosphorylation: two-component systems and the limits of homology. *Trends Biochem. Sci.* **19**, 485-490.
- The Arabidopsis Genome Initiative.** (2000). Analysis of the genome sequence of the flowering plant *Arabidopsis thaliana*. *Nature* **408**, 796-815.
- Tieman, D.M., Taylor, M.G., Ciardi, J.A., and Klee, H.J.** (2000). The tomato ethylene receptors NR and LeETR4 are negative regulators of ethylene response and exhibit functional compensation within a multigene family. *Proc. Natl. Acad. Sci. USA* **97**, 5663-5668.
- Urao, T., Miyata, S., Yamaguchi-Shinozaki, K., and Shinozaki, K.** (2000). Possible His to Asp phosphorelay signaling in an *Arabidopsis* two-component system. *FEBS Letters* **478**, 227-232.
- van Hoof, A., and Green, P.J.** (1996). Premature nonsense codons decrease the stability of phytohemagglutinin mRNA in a position-dependent manner. *Plant J.* **10**, 415-424.
- Wang, W., Hall, A.E., O'Malley, R., and Blecker, A.B.** (2003). Canonical histidine kinase activity of the transmitter domain of the ETR1 ethylene receptor from *Arabidopsis* is not required for signal transmission. *Proc. Natl. Acad. Sci. USA* **100**, 352-357.
- Weigel, D., Ahn, J.H., Blazquez, M.A., Borevitz, J.O., Christensen, S.K., Fankhauser, C., Ferrandiz, C., Kardailsky, I., Malancharuvil, E.J., Neff, M.M., Nguyen, J.T., Sato, S., Wang, Z.Y., Xia, Y., Dixon, R.A., Harrison, M.J., Lamb, C.J., Yanofsky, M.F., and Chory, J.** (2000). Activation tagging in *Arabidopsis*. *Plant Physiol.* **122**, 1003-1013.
- Woeste, K.E., Vogel, J. P., Kieber, J. J.** (1999). Factors regulating ethylene biosynthesis in etiolated *Arabidopsis thaliana* seedlings. *Physiol. Plant.* **105**, 478-484.
- Wu, Y., Haberland, G., Zhou, C., and Koop, H.U.** (1992). Somatic embryogenesis, formation of morphogenetic callus and normal development in zygotic embryos of *Arabidopsis thaliana in vitro*. *Protoplasma* **169**, 89-96.

- Yang, S.F., and Hoffman, N.E.** (1984). Ethylene biosynthesis and its regulation in higher plants. *Annu. Rev. Plant Physiol.* **35**, 155-189.
- Yu, Y.B., Adams, D.O., and Yang, S.F.** (1979). 1-Aminocyclopropanecarboxylate synthase, a key enzyme in ethylene biosynthesis. *Arch. Biochem. Biophys.* **198**, 280-286.
- Zhao, X.C., Qu, X., Mathews, D.E., and Schaller, G.E.** (2002). Effect of ethylene pathway mutations upon expression of the ethylene receptor ETR1 from *Arabidopsis*. *Plant Physiol.* **130**, 1983-1991.

## APPENDIX 1

# Mutational Analysis of the Ethylene Receptor ETR1. Role of the Histidine Kinase Domain in Dominant Ethylene Insensitivity<sup>1</sup>

Rebekah L. Gamble, Xiang Qu, and G. Eric Schaller\*

Department of Biochemistry and Molecular Biology, University of New Hampshire, Durham, New Hampshire 03824

The ethylene receptor family of *Arabidopsis* consists of five members, one of these being ETR1. The N-terminal half of ETR1 contains a hydrophobic domain responsible for ethylene binding and membrane localization. The C-terminal half of the polypeptide contains domains with homology to histidine (His) kinases and response regulators, signaling motifs originally identified in bacteria. The role of the His kinase domain in ethylene signaling was examined in planta. For this purpose, site-directed mutations were introduced into the full-length wild-type ETR1 gene and into *etr1-1*, a mutant allele that confers dominant ethylene insensitivity on plants. The mutant forms of the receptor were expressed in *Arabidopsis* and the transgenic plants characterized for their ethylene responses. A mutation that eliminated His kinase activity did not affect the ability of *etr1-1* to confer ethylene insensitivity. A truncated version of *etr1-1* that lacks the His kinase domain also conferred ethylene insensitivity. Possible mechanisms by which a truncated version of *etr1-1* could exert dominance are discussed.

The simple gas ethylene functions as an endogenous regulator of plant growth and development (Abeles et al., 1992). Ethylene regulates seed germination, seedling growth, leaf and petal abscission, fruit ripening, organ senescence, and pathogen responses. Ethylene perception in *Arabidopsis* is mediated by a family of five receptors: ETR1, ERS1, ETR2, ERS2, and EIN4 (Bleecker, 1999; Chang and Shockey, 1999). Of these receptors, ETR1 has been characterized in most detail because it was the first member of the receptor family identified (Chang et al., 1993; Schaller and Bleecker, 1995).

The N-terminal half of ETR1 is involved in signal input. This region of ETR1 contains three predicted transmembrane segments that encompass the ethylene-binding site (Schaller and Bleecker, 1995). A copper cofactor is a necessary part of the ethylene-binding site, presumably serving to ligand the ethylene (Rodriguez et al., 1999). ETR1 forms a disulfide-linked dimer in the membrane, with dimerization mediated by two cysteines located near the N terminus (Schaller et al., 1995). Following the transmembrane segments, ETR1 contains a GAF domain; GAF domains, initially identified in cGMP-specific and -stimulated phosphodiesterases, adenylate cyclases, and the *Escherichia coli* protein FhIA, are involved in

cGMP binding and light regulation, but their function in ETR1 is unknown (Aravind and Ponting, 1997).

The C-terminal half of ETR1 is likely to be involved in signal output. This portion of the protein contains regions with homology to His kinases and the receiver domains of response regulators (Chang et al., 1993). These represent signaling elements originally identified in bacterial signal transduction systems (Parkinson, 1993), but which are now known to be present in plants and fungi as well (Schaller, 2000). In many of these signal transduction systems, the His kinase domain autophosphorylates at a conserved His residue in response to an environmental stimulus. This phosphate is then transferred to a conserved Asp residue within the receiver domain of the response regulator. Phosphorylation of the response regulator modulates its ability to mediate downstream signaling in the pathway. Some bacterial His kinases also contain a phosphatase activity that will dephosphorylate the response regulator. His kinase activity has been demonstrated for ETR1 (Gamble et al., 1998), but the role of this activity in ethylene signal transduction has not been determined. In addition, ETR1 has been shown to interact through both its His kinase and receiver domains with CTR1 (Clark et al., 1998), a downstream element of the ethylene signal transduction pathway (Kieber et al., 1993). CTR1 is related to the Raf-type Ser/Thr protein kinases from mammals, indicating that ethylene signal transduction could feed into a MAP kinase cascade, with CTR1 representing a MAPKKK (Kieber et al., 1993). ETR1 could potentially regulate activity of CTR1 through enzymatic or allosteric mechanisms.

<sup>1</sup> This work was supported by the National Science Foundation (grant nos. MCB-9603679 and MCB-9982510 to G.E.S.). This is scientific contribution no. 2,107 from the New Hampshire Agricultural Experiment Station.

\* Corresponding author; e-mail [egs@cisunix.unh.edu](mailto:egs@cisunix.unh.edu); fax 603-862-4013.

Article, publication date, and citation information can be found at [www.plantphysiol.org/cgi/doi/10.1104/pp.010777](http://www.plantphysiol.org/cgi/doi/10.1104/pp.010777).

The other four members of the Arabidopsis ethylene receptor family are similar in overall structure to ETR1, with the greatest level of amino acid conservation being found in the ethylene-binding domains (Chang and Shockey, 1999). However, some differences among family members are notable. In particular, ETR2, ERS2, and EIN4 contain diverged His kinase domains and lack residues considered essential for His kinase activity (Chang and Shockey, 1999). Two of the proteins (ERS1 and ERS2) lack a receiver domain at the C terminus (Chang and Shockey, 1999). To directly assess the role of the ethylene receptor family in ethylene perception, loss-of-function mutations have been isolated in four of the five gene members of the family (Hua and Meyerowitz, 1998). Single loss-of-function mutations have little or no effect upon ethylene signal transduction. However, in combination, the mutants show constitutive ethylene responses. This effect is most pronounced in triple and quadruple loss-of-function mutations (Hua and Meyerowitz, 1998). These results indicate that there is functional redundancy among the receptor family members. In addition, because elimination of receptors activates ethylene responses, these results support a model in which the receptors repress the ethylene responses in the absence of ethylene. According to this model, binding of ethylene inactivates receptor signaling, thereby relieving the repression on the ethylene pathway.

Dominant ethylene-insensitive mutations of the receptors have been identified that apparently lock the receptor into a signaling state such that it represses ethylene responses whether the plants are grown in the presence or absence of ethylene. Dominant ethylene insensitivity can be conferred by mutations in the receptor that disrupt ethylene binding or that uncouple ethylene binding from signal output (Hall et al., 1999). The dominant *etr1-1* mutation arises from the change of a single amino acid (Cys65Tyr) and has been shown to eliminate binding of the copper cofactor and consequently prevents ethylene binding to the receptor (Schaller and Bleecker, 1995; Rodriguez et al., 1999). A mutation within the ethylene-binding site of any one of the five receptor isoforms can result in dominant ethylene insensitivity (Chang et al., 1993; Hua et al., 1995, 1998; Sakai et al., 1998). The effect of dominant ethylene-insensitive mutations is not limited to Arabidopsis (Wilkinson et al., 1997). The Arabidopsis *etr1-1* mutant can confer dominant ethylene insensitivity in transgenic tomato (*Lycopersicon esculentum*; Wilkinson et al., 1997), a genetic background in which tomato would be expressing its own family of at least five ethylene receptors (Tieman and Klee, 1999). Similarly, introduction of mutant tomato ethylene receptors into Arabidopsis also confers dominant ethylene insensitivity (Tieman and Klee, 1999). In this study, we used the mutant receptor *etr1-1* as a tool to examine ethylene signal transduction in Arabidopsis, studies fa-

cilitated by the dominant nature of this mutation. We focused on the role that the His kinase domain plays in mediating the effects of the *etr1-1* mutant receptor. Our results lend insight into the mechanism of dominance of the *etr1-1* mutation and also into the general mechanism of ethylene signal transduction.

RESULTS

A G2 Box Mutation Eliminates His Kinase Activity of the Ethylene Receptor ETR1

The ETR1 protein has a modular structure, with His kinase and receiver domains located in the C-terminal half of the protein (Fig. 1A). The His kinase domain contains conserved residues considered essential for enzymatic activity based on the well-characterized His kinases of bacteria (Stock et al., 1995). These include a His residue that serves as the presumptive site of autophosphorylation and a catalytic domain with two regions of conserved Gly residues referred to as the G1 and G2 boxes. To

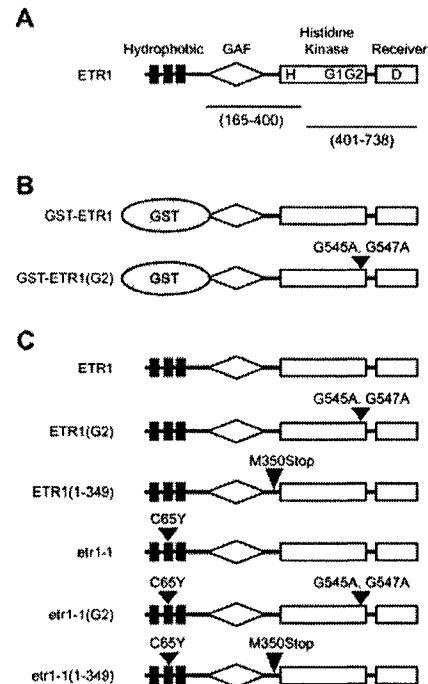

Figure 1. Structure of ETR1 and constructs used for experimental analysis. The hydrophobic ethylene-sensing domain, the GAF domain, the His kinase domain, and the receiver domain are indicated. H indicates His-353 and D indicates Asp-659, the putative phosphorylation sites. G1 and G2 indicate positions of the G1 and G2 boxes within the kinase domain. A, Domains of the full-length ETR1 protein. Positions of regions used to generate the anti-ETR1(165-400) and anti-ETR1(401-738) antibodies are indicated. B, Versions of ETR1 expressed as glutathione S-transferase (GST) fusions in yeast. C, Versions of ETR1 expressed as transgenes in Arabidopsis.

analyze His kinase activity of ETR1, we transgenically expressed soluble portions of the protein as fusions with GST (Fig. 1B) in yeast (*Saccharomyces cerevisiae*; Gamble et al., 1998). As shown in Figure 2, the purified GST-ETR1 fusion exhibits autophosphorylation activity. The incorporated phosphate is resistant to alkali treatment, but is sensitive to acid treatment, consistent with phosphorylation of a His residue (Fig. 2; Duclos et al., 1991). We have shown previously that autophosphorylation can be abolished by mutations that eliminate either the presumptive site of autophosphorylation (His-353) or residues within the G1 box of the catalytic domain of ETR1 (Gamble et al., 1998). Mutation of the G2 box is also predicted to abolish His kinase activity because it contains conserved residues implicated in ATP binding (Bilwes et al., 1998). We observed no phosphorylation in a GST-ETR1 fusion containing a mutated G2 box (G545A and G547A), demonstrating the necessity of the G2 box for His kinase activity (Fig. 2). Western-blot analysis was performed to confirm equivalent protein loading.

Effect of a G2 Box Mutation in the Ethylene Receptor on the Seedling Growth Response

To study the *in vivo* effects of mutations in the ETR1 ethylene receptor, we took advantage of the ethylene-induced "triple response" in seedlings (Knight et al., 1910). Ethylene has a pronounced effect upon wild-type seedlings grown in the dark. As shown in Figure 3A, the triple response of *Arabidopsis* seedlings to ethylene is characterized by an inhibition of hypocotyl and root elongation, an exaggerated apical hook, and a thickening of the hypocotyl (Bleecker et al., 1988; Guzmán and Ecker, 1990). The *etr1-1* ethylene-insensitive mutant of *Arabidopsis* lacks the triple response and instead has the elongated hypocotyl and characteristic etiolated morphology of an air-grown seedling (Fig. 3A; Bleecker et al., 1988).

To examine the function of ETR1 and *etr1-1* as transgenes in planta, 7.3-kb genomic fragments containing promoter and coding regions were cloned

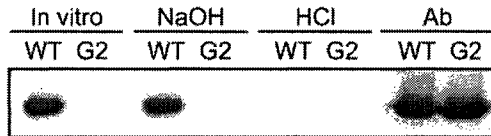

Figure 2. *In vitro* phosphorylation of ETR1. A wild-type (WT) and G2-box mutant version (G2) of the fusion-protein GST-ETR1 were examined for the ability to autophosphorylate. Affinity-purified proteins were incubated with <sup>32</sup>P-ATP, subjected to SDS-PAGE, then transferred to nylon membrane (*in vitro*). Proteins were then sequentially treated with alkali (NaOH) and acid (HCl). Incorporated phosphate was visualized after each treatment by autoradiography. Finally, protein was visualized by western blot using the anti-ETR1(401-738) antibody.

1430

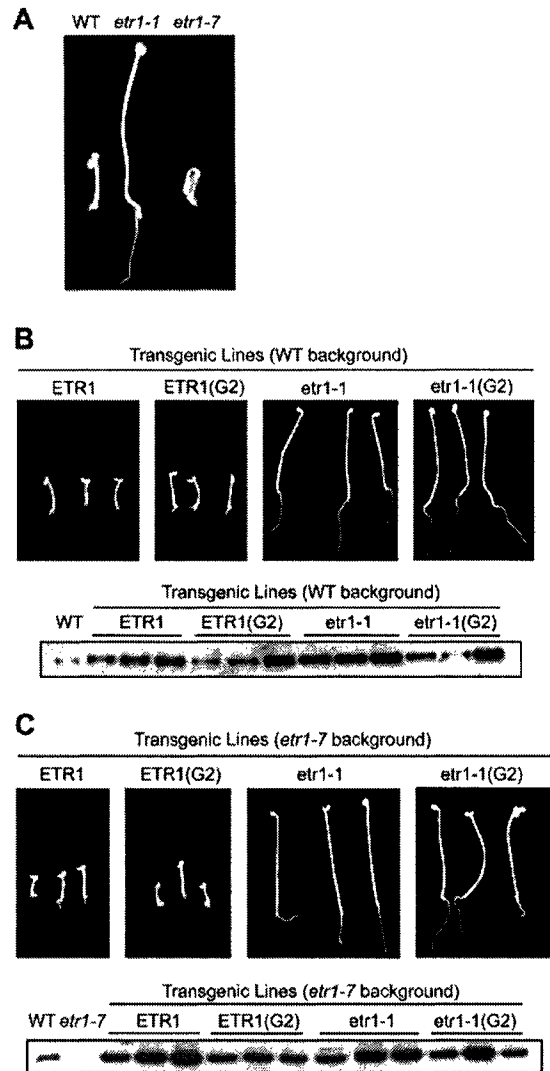

Figure 3. Effect of mutant ETR1 receptors upon the triple response of dark-grown seedlings. Phenotypes of 4-d-old seedlings grown in 35 L L<sup>-1</sup> ethylene are shown. Representative seedlings from three independent lines for each transgene are shown. The level of immunodetectable full-length receptor for each of the plant lines was determined by western-blot analysis using the anti-ETR1(401-738) antibody. A, Response of wild type (WT), the ethylene-insensitive mutant *etr1-1*, and the loss-of-function mutant *etr1-7* to ethylene. B, Ethylene response of the wild-type *Arabidopsis* transformed with ETR1, ETR1(G2), *etr1-1*, and *etr1-1*(G2). C, Ethylene response of the loss-of-function *etr1-7* line transformed with ETR1, ETR1(G2), *etr1-1*, and *etr1-1*(G2).

into plant transformation vectors and used to transform *Arabidopsis*. Transgenic seedlings were initially identified on the basis of kanamycin resistance (*kan<sup>r</sup>*), and the subsequent generation was scored for

Plant Physiol. Vol. 128, 2002

ethylene sensitivity based on the triple response. Transformation of wild-type plants with the *etr1-1* genomic clone yielded ethylene-insensitive plants with high frequency (Table I; Fig. 3B). In contrast, all of the plants transformed with a wild-type ETR1 genomic fragment displayed the normal triple response to ethylene (Table I; Fig. 3B). The expression level of ETR1 protein in transgenic plants was determined by performing western-blot analysis on membranes isolated from etiolated seedlings (Fig. 3B). Both the ETR1 and *etr1-1* transgenic lines had higher levels of the immunodetectable protein when compared with the level in wild-type seedlings; this is consistent with expression of the transgene. The amount of immunodetectable protein was similar in both the ETR1 and *etr1-1* transgenic lines; therefore, an increased level of expression cannot account for the ethylene insensitivity observed in the *etr1-1* transgenic lines.

The wild-type and *etr1-1* genomic fragments were mutated to eliminate residues of the G2 box (Fig. 1C). The G2 box was chosen for mutation because it eliminates His kinase activity of ETR1 (Fig. 2). In addition, mutation of the G2 box should eliminate any potential phosphatase activity of the protein (Yang and Inouye, 1993), an additional enzymatic activity found in some bacterial His kinases. Wild-type plants transformed with *etr1-1(G2)* yielded ethylene-insensitive seedlings with high frequency, but all wild-type plants transformed with ETR1(G2) displayed the triple response to ethylene (Table I; Fig. 3B). Immunodetectable ETR1 protein in the ETR1(G2) and *etr1-1(G2)* transgenic lines demonstrated similar variability in their expression levels, and were above the level of ETR1 in wild-type seedlings. Thus, the ethylene insensitive phenotype produced by *etr1-1* does not require enzymatic activity of the His kinase domain. Ethylene insensitivity is dominant because the genetic background contains wild-type ETR1.

To examine the effect of the transgenes in a background that lacked ETR1, we transformed the same constructs into the *etr1-7* genetic background. The *etr1-7* mutant is a loss-of-function allele of ETR1 that arises from a stop codon at Trp74 (Hua and Meyerowitz, 1998). Dark-grown seedlings of *etr1-7* are responsive to ethylene (Fig. 3A) and do not make any immunodetectable ETR1 protein (Fig. 3C). The ethylene responsiveness of the *etr1-7* mutant is mediated by the remaining four members of the ethylene receptor family. Results from the expression of transgenes in the *etr1-7* background were similar to those obtained with the wild-type background (Table I; Fig. 3). Both *etr1-1* and *etr1-1(G2)* conferred ethylene insensitivity upon transgenic *etr1-7* seedlings. Control lines transformed with ETR1 or ETR1(G2) were responsive to ethylene. The levels of immunodetectable ETR1 protein correspond to expression from the transgene because of the absence of endogenous ETR1 protein (Fig. 3C). Thus, kinase activity is not required for the ethylene insensitivity conferred by *etr1-1* in a genetic background that lacks wild-type ETR1.

#### Effect of a Truncated Receptor on the Seedling Growth Response

To further assess the role of the C-terminal half of ETR1 in ethylene responses, we generated truncated versions of the receptor that lacked the His kinase and receiver domains. Truncated versions of the receptor were coded for in the 7.3-kb genomic fragments by mutation of Met350 to a stop codon (Fig. 1). Although nonsense-mediated decay of mRNAs containing premature stop codons has been demonstrated to occur in plants (van Hoof and Green, 1996), we have observed that message is still produced from the ETR1 loss-of-function mutations that contain premature stop codons (X. Qu and G.E. Schaller, unpublished data). Thus, by the introduction of stop

Table I. Ethylene sensitivity of transgenic lines

Transgenic lines were initially identified on the basis of kan<sup>r</sup>. Seeds from the subsequent generation of each line were then screened for the presence of ethylene-insensitive seedlings using the triple-response assay.

Transgene	Background	kan <sup>r</sup> Lines	Ethylene- Insensitive Lines	Ethylene- Insensitive Lines %
ETR1	WT	10	0	0
ETR1(G2)	WT	12	0	0
ETR1(1-349)	WT	16	0	0
<i>etr1-1</i>	WT	14	13	93
<i>etr1-1(G2)</i>	WT	10	10	100
<i>etr1-1(1-349)</i>	WT	12	10	83
ETR1	<i>etr1-7</i>	12	0	0
ETR1(G2)	<i>etr1-7</i>	13	0	0
ETR1(1-349)	<i>etr1-7</i>	22	0	0
<i>etr1-1</i>	<i>etr1-7</i>	17	13	76
<i>etr1-1(G2)</i>	<i>etr1-7</i>	20	15	75
<i>etr1-1(1-349)</i>	<i>etr1-7</i>	16	7	44

codons, truncated versions of ETR1 can theoretically be produced that preserve downstream non-coding determinants of expression. Mutant versions of the receptor were cloned into a plant transformation vector and used to transform Arabidopsis.

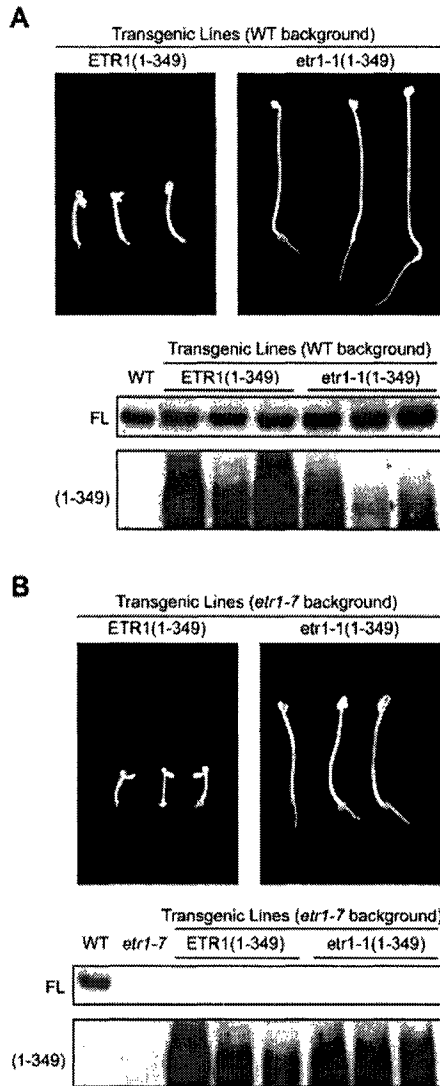

Figure 4. Effect of the ETR1(1-349) and *etr1-1*(1-349) mutant receptors upon the triple response. The ETR1(1-349) and *etr1-1*(1-349) transgenes were transformed into either wild-type Arabidopsis (A) or into the loss-of-function *etr1-7* line (B). Representative seedlings from three independent lines for each transgene are shown after 4 d growth in  $35 \mu\text{L L}^{-1}$  ethylene. The level of immunodetectable full-length receptor (FL) for each of the plant lines was determined by western-blot analysis using the anti-ETR1(401-738) antibody with  $10 \mu\text{g}$  protein. The level of immunodetectable protein for the truncated receptors (1-349) was determined using the anti-ETR1(165-400) antibody.

1432

As shown in Table I and Figure 4A, wild-type plants transformed with *etr1-1*(1-349) yielded ethylene-insensitive seedlings at high frequency. In contrast, all wild-type plants transformed with the control ETR1(1-349) were sensitive to ethylene. An immunodetectable protein was recognized by an antibody generated against amino acids 165 through 400 of ETR1 (Fig. 4A) in the transgenic lines at a molecular mass consistent with that of a truncated receptor. As expected, we still observed the full-length ETR1 receptor endogenous to the wild-type line into which the transgenes were transformed (Fig. 4A). The levels of full-length ETR1 detected in the transgenic lines were similar to those found in the control wild-type line, indicating that expression of the truncated receptor did not affect expression of the native full-length receptor. Based on these results, we concluded that a truncated version of the *etr1-1* mutant receptor lacking the His kinase and receiver domains was still capable of conferring dominant ethylene insensitivity upon wild-type plants.

ETR1(1-349) and *etr1-1*(1-349) were also transformed into the *etr1-7* genetic background of Arabidopsis so as to observe their effects on a plant that lacks ETR1. Ethylene insensitivity was observed in plants transformed with *etr1-1*(1-349), but not in plants transformed with the control ETR1(1-349) (Table I; Fig. 4B). Western-blot analysis confirmed that the transgenic *etr1-7* lines lacked the full-length ETR1 receptor but expressed a truncated version of the receptor.

#### Quantitative Analysis of the Seedling Growth Response to Ethylene

To gain more information about the ethylene insensitivity conferred by the transgenes, we performed a quantitative analysis. We primarily focused on the transgenic *etr1-7* lines because, lacking the native ETR1 receptor, the level of protein expression from the transgene can be immunologically determined. Quantitative analysis of ethylene responses was performed with transgenic lines that segregated for *kan<sup>r</sup>* as single loci, using homozygous seed obtained from plants allowed to self-pollinate. For each transgene, two independent transgenic lines were characterized that had been scored as ethylene insensitive based on their lack of a triple-response phenotype. Seedlings were grown in the dark in ethylene concentrations ranging from 0 to  $1,000 \mu\text{L L}^{-1}$ , and hypocotyl lengths measured after 4 d growth. Transgenic lines containing different versions of *etr1-1* were compared with control untransformed lines.

As shown in Figure 5, A through D, two independent transgenic *etr1-7* lines containing the *etr1-1* and *etr1-1*(G2) transgenes showed no responsiveness to ethylene even at the highest ethylene concentration tested ( $1,000 \mu\text{L L}^{-1}$ ). In contrast, two independent transgenic *etr1-7* lines containing the *etr1-1*(1-349)

Plant Physiol. Vol. 128, 2002



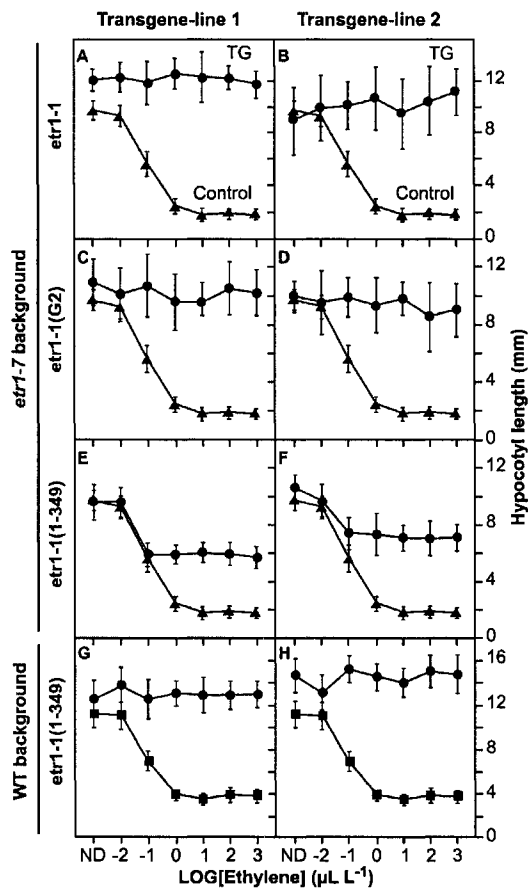

Figure 5. Ethylene dose response curves of hypocotyl growth for *etr1-1* mutants. Dose response curves from two independent transgenic lines (black circles, TG) for each transgene are shown. Results are shown for *etr1-1* (A and B), *etr1-1(G2)* (C and D), and *etr1-1(1-349)* (E and F) in the *etr1-7* background. Results are also shown for *etr1-1(1-349)* in a wild-type background (G and H). For comparison, ethylene dose response curves are shown for control wild-type (black square) and *etr1-7* (black triangle) hypocotyls. Values represent the means  $\pm$  SD of 25 measurements. ND, No detectable ethylene.

transgene did show some responsiveness to ethylene (Fig. 5, E and F). In line 1 of *etr1-1(1-349)*, hypocotyl length decreased from 9.6 to 5.7 mm. In line 2 of *etr1-1(1-349)*, hypocotyl length decreased from 10.5 to 7.0 mm. In the control untransformed *etr1-7* line, hypocotyl length decreased from 9.7 to 1.8 mm. Thus, line 1 had a maximum ethylene response of 49% and line 2 had a maximum ethylene response of 44% compared with the control. The partial ethylene responsiveness of the *etr1-1(1-349)* transgenic lines does not result from a shift in ethylene sensitivity because the seedlings showed no significant change in hypocotyl length from 1 to 1,000  $\mu\text{L L}^{-1}$  ethylene. In contrast to what we observed in the *etr1-7* back-

Plant Physiol. Vol. 128, 2002

ground, two wild-type lines transformed with *etr1-1(1-349)* transgene showed no responsiveness to ethylene over all ethylene concentrations tested (Fig. 5, G and H).

#### Western-Blot Analysis of Transgenic Lines

We performed western-blot analysis to gain information on expression of the transgenes at the protein level. Western-blot analysis was performed on membranes isolated from the same transgenic lines used for the quantitative seedling growth response assay. The full-length receptor migrated at a molecular mass of 77 kD in the presence of reducing agent, consistent with the predicted molecular mass of 82 kD, and was recognized by both the anti-ETR1(165-400) and the anti-ETR1(401-738) antibodies (Fig. 6A). As expected, full-length receptor was detected in the wild-type and *etr1-1* backgrounds, but not in the *etr1-7* background. In addition, full-length receptor was detected in the *etr1-7* background when *etr1-1* and *etr1-1(G2)* were transgenically expressed. Analysis with the anti-ETR1(401-738) antibody confirms

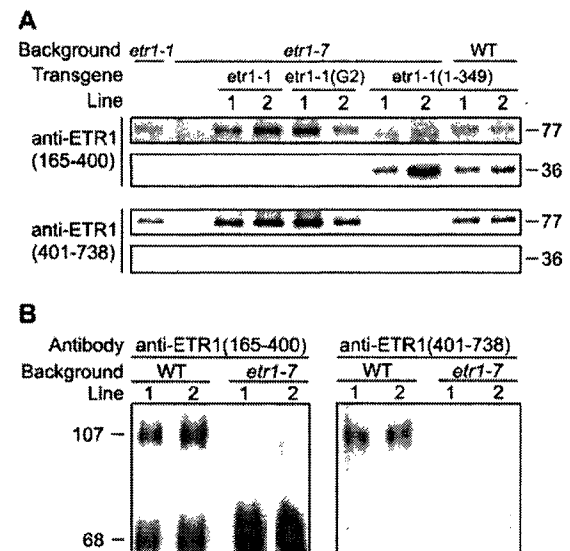

Figure 6. Western-blot analysis of transgenic lines containing mutant versions of *etr1-1*. Membrane fractions from etiolated Arabidopsis seedlings were incubated in the presence (A) or absence (B) of 100 mM dithiothreitol (DTT) for 1 h at 37°C. Protein (5  $\mu\text{g}$ ) was subjected to SDS-PAGE and then analyzed by western blot using the anti-ETR1(165-400) and anti-ETR1(401-738) antibodies. A, Expression levels of wild-type and mutant versions of ETR1 in different genetic backgrounds. In the presence of the reducing agent DTT, the full-length receptor migrates as a 77-kD monomer and the truncated *etr1-1(1-349)* receptor migrates as a 36-kD monomer. B, Disulfide-linked dimers formed by *etr1-1(1-349)* expressed in wild-type and *etr1-7* backgrounds. Positions of the 68-kD *etr1-1(1-349)* homodimer and of the putative 107-kD *etr1-1(1-349):ETR1* dimer are indicated.

1433

that no detectable full-length receptor is present in the *etr1-7* background line when expressing the truncated *etr1-1(1-349)* receptor. It should be noted that the anti-ETR1(165-400) antibody, but not the anti-ETR1(401-738) antibody, detects a minor protein migrating at slightly lower molecular mass than the 77-kD full-length receptor when *etr1-1(1-349)* is expressed in the *etr1-7* background. However, as discussed below, this protein is coincident with the 68-kD disulfide-linked dimer of *etr1-1(1-349)*, and thus apparently represents residual protein that has not been completely reduced. The truncated ethylene receptor *etr1-1(1-349)* migrated at a molecular mass of 36 kD in the presence of reducing agent, consistent with the predicted molecular mass of 40 kD (Fig. 6A). The truncated ethylene receptor was recognized by the anti-ETR1(165-400) antibody but not by the anti-ETR1(401-738) antibody.

Differences in protein expression levels would represent a trivial explanation for the differences in the effectiveness of the various mutant forms of *etr1-1* at conferring dominant ethylene insensitivity. However, the greater effectiveness of *etr1-1* and *etr1-1(G2)* compared with *etr1-1(1-349)* in the *etr1-7* background did not correlate with higher levels of expression. For example, line 2 of *etr1-1(G2)* has a lower level of expression than either of the *etr1-1(1-349)* lines. These results are indicative that the C-terminal half of the protein, but not necessarily enzymatic activity, is required for maximal effectiveness of the *etr1-1* mutant. In addition, the greater effectiveness of *etr1-1(1-349)* in the wild-type background compared with its effectiveness in the *etr1-7* background did not correlate with higher levels of expression in the wild-type background. For example, the highest level of *etr1-1(1-349)* was found in line 2 in the *etr1-7* background. These results are suggestive that the effectiveness of *etr1-1(1-349)* is greater in the presence of a full-length wild-type ETR1 receptor, potentially indicating some form of interaction between the two.

The ethylene receptor ETR1 has been demonstrated to form a disulfide-linked dimer, mediated by Cys-4 and Cys-6, that has an apparent molecular mass of 147 kD when analyzed by SDS-PAGE (Schaller et al., 1995). To assess whether the truncated *etr1-1* receptor was still capable of dimerizing, we ran SDS-PAGE in the absence of reducing agent to preserve disulfide linkages (Fig. 6B). When visualized with anti-ETR1(165-400), a species with an apparent molecular mass of 68 kD was observed in both wild-type and *etr1-7* backgrounds. This oxidized species is approximately twice the mass of the 36-kD *etr1-1(1-349)* monomer and is not recognized by the anti-ETR1(401-738) antibody, consistent with the species representing a disulfide-linked dimer of the truncated receptor. It is interesting that a second major immunodetectable species of 107 kD was observed in the wild-type background, but was absent from the

*etr1-7* background. The species of 107 kD is of a molecular mass consistent with that of a heterodimer between *etr1-1(1-349)* and the native wild-type ETR1. The presence of the native ETR1 at this molecular mass was confirmed by western blot with anti-ETR1(401-738), an antibody capable of recognizing the native full-length protein but not the truncated *etr1-1* protein.

## DISCUSSION

Genetic analysis supports the model shown in Figure 7, whereby ethylene receptors actively repress ethylene responses in the air (Fig. 7A; Hua and Meyerowitz, 1998; Bleecker, 1999). In the presence of ethylene, wild-type receptors switch to a signaling-inactive state that allows for induction of ethylene responses (Fig. 7B). Although His kinase activity has been demonstrated for the ethylene receptor ETR1 (Gamble et al., 1998), the role of this activity in signaling is unknown. Simple mutational analysis to uncover the function of the His kinase domain is confounded by the presence of other nonmutant members of the receptor family. Loss-of-function mutations in individual members of the receptor family have minimal effect upon the ability of Ara-

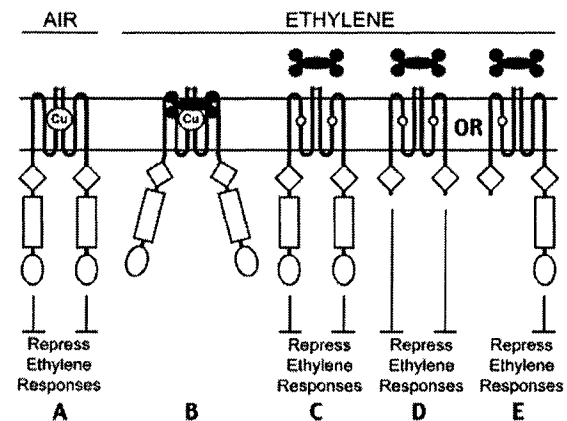

Figure 7. Models for signaling by wild-type and mutant versions of the ethylene receptor ETR1. The ethylene receptor ETR1 contains one ethylene-binding site per homo-dimer, with ethylene binding mediated by a single copper ion (Cu) present in the ethylene binding site. In air, receptors actively repress ethylene responses (A). In ethylene, receptors are inactivated, thereby relieving repression of the ethylene response pathway (B). The *etr1-1* mutation (indicated by a white circle) eliminates binding of the necessary copper cofactor so that the receptor represses ethylene responses even in the presence of ethylene (C). A truncated *etr1-1(1-349)* receptor is still able to repress the ethylene responses. This could arise because of innate signaling activity of the *etr1-1(1-349)* receptor (D). Alternatively, *etr1-1(1-349)* could "convert" a full-length wild-type receptor to a ethylene-insensitive signaling state (E). A dimer between the truncated *etr1-1(1-349)* receptor and a full-length wild-type ETR1 receptor does not bind ethylene and consequently the ETR1 portion of the dimer represses ethylene responses.

bidopsis to respond to ethylene (Hua and Meyerowitz, 1998). We found that a G2 box mutation and a truncation of ETR1 had no apparent effect on the ability of the plant to respond to ethylene. However, ethylene responses could still be mediated by another member of the receptor family, such as ERS1, which contains a His kinase domain with all the conserved residues required for activity (Hua et al., 1995).

The problems inherent in mutational analysis of a gene family can be circumvented in part by use of gain-of-function mutations such as *etr1-1*. The *etr1-1* mutant receptor of *Arabidopsis* is apparently locked into the signaling state that it has in the absence of ethylene. This state arises as a consequence of the mutant receptor's inability to bind ethylene, so that it represses ethylene responses even in the presence of ethylene (Fig. 7C; Schaller and Bleeker, 1995). Because *etr1-1* remains locked in its active state in the presence of ethylene, when other members of the receptor family are signaling inactive, mutational analysis of *etr1-1* can lend insight into the requirements for signaling by the receptor. Our focus in this set of experiments has been on *etr1-1* and the role of the His kinase domain in signaling.

Our data indicate that enzymatic activity is not required for the ethylene insensitivity conferred by the mutant *etr1-1* receptor. We found that an *etr1-1* mutant that contains a G2 box mutation was as effective as *etr1-1* itself in conferring ethylene insensitivity. As demonstrated in this report, the G2-box mutation eliminates His kinase activity in ETR1; this mutation is also predicted to eliminate any potential phosphatase activity of the protein (Yang and Inouye, 1993). It has been reported previously that *etr1-1* is still able to confer dominant ethylene insensitivity when the His and Asp residues predicted to serve as phosphorylation sites are mutated (Chang and Meyerowitz, 1995). These data are consistent with the finding that ethylene-insensitive mutants can be generated in the ethylene receptors ETR2, ERS2, and EIN4, all of which contain diverged His kinase domains predicted to lack His kinase activity (Hua et al., 1998; Sakai et al., 1998). In addition, a tomato ethylene receptor with diverged kinase domain appears able to functionally compensate for an ethylene receptor containing a conserved kinase domain (Tieman et al., 2000).

We also found that ethylene insensitivity could be conferred by the truncated *etr1-1*(1-349) receptor that lacks the C-terminal half of the protein containing the His kinase domain. The truncated *etr1-1*(1-349) receptor conferred complete dominant ethylene insensitivity upon wild-type seedlings. However, *etr1-1*(1-349) did not confer ethylene insensitivity as effectively as full-length versions of *etr1-1*, when analyzed in the *etr1-7* genetic background that lacks ETR1. Dose response curves indicate that the ethylene responsiveness of these seedlings was reduced,

rather than the sensitivity of the seedlings to ethylene shifted such that higher levels of ethylene were required to initiate the response. Partial ethylene insensitivity with a similar response to ethylene treatment has been observed in gene dosage experiments in which the ratio of wild-type to mutant *etr1-1* genes was increased by use of a triploid background (Hall et al., 1999). Partial ethylene insensitivity has also sometimes been observed when full-length *etr1-1* is expressed as a transgene in a wild-type background, presumably because of low expression of the transgene (Chang et al., 1993).

Use of the *etr1-7* background allowed us to directly compare protein expression levels from the various transgenes encoding full-length and truncated receptors. The decreased effectiveness of *etr1-1*(1-349) in the *etr1-7* background did not correlate with a reduced protein level compared with the full-length versions of *etr1-1*. Thus, our analysis of the truncated receptor supports a role for the C-terminal half of *etr1-1* in the ability to confer ethylene insensitivity. The role of the C-terminal half for ethylene insensitivity could be in signal output, potentially for interactions with downstream signaling factors such as CTR1 (Kieber et al., 1993; Clark et al., 1998) because we found no evidence that His kinase activity was required for ethylene insensitivity. Alternatively, the C-terminal half could be important for proper folding of the protein; in such cases, the protein levels for *etr1-1*(1-349) determined by western-blot analysis may not accurately reflect the level of functional protein.

It is surprising that although the C-terminal half of *etr1-1* increased the ability of *etr1-1* to confer ethylene insensitivity under some conditions, it was not essential to this ability. Thus, the truncated version of *etr1-1* is able to still mediate the active repression of ethylene responses. One explanation for this ability would be that the *etr1-1*(1-349) receptor is directly capable of signal output (Fig. 7D), potentially through its GAF domain (Aravind and Ponting, 1997), the function of which has not been determined for the ethylene receptors. Alternatively, the *etr1-1*(1-349) receptor might be incapable of signal output itself, but be able to "convert" other wild-type receptors to an ethylene-insensitive signaling state (Fig. 7E). One method by which such conversion could occur is suggested by our evidence that *etr1-1*(1-349) can form a disulfide-linked dimer with wild-type ETR1. Studies by Rodriguez et al. (1999) support the existence of a single ethylene-binding site per ETR1 dimer. As a consequence, a dimer of *etr1-1*(1-349) and ETR1 would likely result in neither polypeptide being able to bind ethylene because of the mutation within the shared ethylene-binding domain (Fig. 7E). The ETR1 portion of an *etr1-1*(1-349):ETR1 dimer thus would remain in a signaling-active state and still repress ethylene responses in the presence of ethylene. Our finding that the truncated *etr1-1*(1-349) re-

ceptor appeared to be more effective at conferring ethylene insensitivity when analyzed in a genetic background that still had a full-length wild-type ETR1 receptor is suggestive that interactions between *etr1-1*(1–349) and wild-type ETR1 may be of physiological relevance.

Dimerization of *etr1-1*(1–349) with ETR1 represents a mechanism by which ETR1 could be converted to an ethylene-insensitive signaling state. Whether *etr1-1*(1–349) is capable of converting other members of the ethylene receptor family besides ETR1 to an ethylene-insensitive signaling state remains an open question. In the *etr1-7* background, *etr1-1*(1–349) predominantly formed disulfide-linked homodimers, even though four non-ETR1 members of the Arabidopsis ethylene receptor family were present. However, different members of the ethylene receptor family could potentially interact through non-covalent associations. In bacteria, His kinases and the related chemoreceptors form non-covalently linked dimers that are important in signal propagation (Pan et al., 1993; Parkinson, 1993). In addition, bacterial chemoreceptors are hypothesized to propagate signals through noncovalent associations with neighboring receptors as large multimeric complexes (Bray et al., 1998). The discovery from crystal structure that the receiver domains of ETR1 form non-covalently linked dimers is indicative that noncovalent associations between ethylene receptors may play an important role in signaling (Muller-Dieckmann et al., 1999).

## MATERIALS AND METHODS

### Expression in Yeast (*Saccharomyces cerevisiae*)

For expression of GST fusions in yeast, the vector pEG(KT) was used (Mitchell et al., 1993). This vector contains the GST domain under control of a Gal-inducible promoter and allows for uracil selection in yeast. The GST fusions were designed to express that portion of ETR1 corresponding to amino acids 164 through 738 (Gamble et al., 1998). Site-directed mutation of ETR1 was performed using the Altered Sites Mutagenesis System (Promega, Madison, WI) according to the manufacturer and confirmed by sequencing. The G2-box mutation coded for a conversion of Gly-545 (GGG) to Ala (GCG) and a conversion of Gly-547 (GGC) to Ala (GCC). Transformation of yeast, isolation of GST fusion proteins, and *in vitro* analysis of His kinase activity was performed as previously described (Gamble et al., 1998). Upon request, these constructs and all novel materials described in this publication will be made available in a timely manner for noncommercial research purposes.

### Expression in Arabidopsis

For expression of ETR1 in Arabidopsis, a 7.3-kb genomic clone containing promoter, coding, and downstream sequence (Chang et al., 1993) was ligated into the BamHI and Sall sites of the binary vector pBIN19 (Bevan, 1984) as

previously described (Hall et al., 1999). For expression of *etr1-1*, a 7.3-kb genomic clone with BamHI linkers (Chang et al., 1993) was ligated into pBIN19. For construction of site-directed mutations, the ETR1 and *etr1-1* genomic clones were subcloned into pALTERII and mutations made using the Altered Sites Mutagenesis System (Promega). To produce truncated versions of the receptor, site-directed mutations were introduced that converted the codon for Met-350 (ATG) into a Stop codon (TAG). Site-directed mutants were confirmed by sequencing, excised from the pALTERII vector, and subcloned into pBIN19.

Constructs in the pBIN19 vector were introduced into *Agrobacterium tumefaciens* strain GV3101 and used to transform Arabidopsis ecotype Columbia by the dipping method (Bent and Clough, 1998). Seeds were plated onto agar plates, and transformed plants selected based on kan<sup>r</sup> (50 g mL<sup>-1</sup>). Plants were allowed to self-pollinate and homozygous lines identified in subsequent generations. Arabidopsis plants were grown in a 3:1 (v/v) mixture of Metromix 360 (Scotts-Sierra Horticultural Products, Marysville, OH) to perlite, and watered with 10% (v/v) Hoagland solution. Plants were maintained in an environmental growth chamber at 22°C with an 18-h daylength.

PCR was used to confirm the presence of the G2 mutation in the *etr1-1*(G2) transgenic line (*etr1-7* background). Seedling tissue was alkali treated and PCR performed as described (Klimyuk et al., 1993) using Pfu DNA polymerase (Stratagene, La Jolla, CA). Amplification was performed using 5' primer ATGCTCATGATCTGTCTACGCTACG and 3' primer TTACCCTCCATCAGATTCACAAACC. The PCR product was cloned into the vector pstBlue-1 according to the manufacturer (Novagen, Madison, WI), and the region encoding the G2 box sequenced.

### Seedling Growth Response Assays

To examine the triple response of seedlings to ethylene (Chen and Bleecker, 1995; Hall et al., 1999), seeds were plated on petri dishes containing one-half-strength Murashige and Skoog basal media with Gamborg's vitamins (Sigma, St. Louis) and 0.8% (w/v) agar. Aminoethylvinyl-Gly (5  $\mu$ M) was included in the growth media to inhibit ethylene biosynthesis by the seedlings. Plates were placed at 4°C in the dark for 2 d to help coordinate seed germination, and then placed at 22°C under fluorescent light for 8 h. Plates were then placed in 4-L containers and seedlings grown in the dark. For the experiments shown in Figures 3 and 4, flow-through containers were used with an ethylene concentration of 35  $\mu$ L L<sup>-1</sup>. For the experiment shown in Figure 5, ethylene was added to sealed containers at the desired concentration. Seedlings were examined after 4 d, time 0 corresponding to when the plates were removed from 4°C and brought to 22°C. To measure hypocotyl length, seedlings were grown on vertically oriented plates. Seedlings on the plates were scanned using Photoshop (Adobe Systems, Mountain View, CA) and a LaCie scanner, and measurements made using NIH Image (version 1.60, National Institutes of Health, Bethesda, MD).

### Membrane Protein Isolation

For isolation of Arabidopsis membranes, 4-d-old etiolated seedlings (1 g) were homogenized at 4°C in extraction buffer (50 mM Tris, pH 8.0; 150 mM NaCl; 10 mM EDTA; and 20% [v/v] glycerol) containing 1 mM phenylmethylsulfonyl fluoride, 10 g mL<sup>-1</sup> leupeptin, and 1 g mL<sup>-1</sup> pepstatin as protease inhibitors. The homogenate was strained through Miracloth (Calbiochem-Novabiochem, San Diego) and centrifuged at 8,000g for 15 min. The supernatant was centrifuged at 100,000g for 30 min, and the membrane pellet resuspended in 10 mM Tris, pH 7.5; 150 mM NaCl; 1 mM EDTA; and 10% (v/v) glycerol with protease inhibitors. Protein concentration was determined by a modification of the Lowry method, in which membrane proteins were extracted with 0.4% (w/v) deoxycholate (Schaller and DeWitt, 1995). Bovine serum albumin was used as the protein standard.

### Western-Blot Analysis

Proteins were resuspended in SDS/PAGE loading buffer in the absence or presence of 100 mM DTT (Schaller et al., 1995). The reductant DTT was left out of the loading buffer when it was desired to preserve the disulfide-linked dimer of ETR1 (Schaller et al., 1995). Membrane proteins were treated at 37°C for 1 h and then fractionated by SDS-PAGE on either 8% or 10% (w/v) polyacrylamide gels (Laemmli, 1970). After electrophoresis, proteins were electroblotted to Immobilon nylon membrane (Millipore, Bedford, MA). Two antibodies were used for western-blot analysis. One antibody, termed anti-ETR1(401–738), was generated against amino acids 401 through 738 of ETR1 (Schaller et al., 1995), and was used to identify versions of ETR1 that contained the His kinase domain. A second antibody, termed anti-ETR1(165–400), was generated against amino acids 165 through 400 of ETR1 (Schaller et al., 1995), and was used to identify truncated versions of ETR1 that lacked the His kinase domain. The anti-ETR1(165–400) antibody recognizes the dimeric form of ETR1 preferentially over the monomeric form (Schaller et al., 1995) so, unless indicated otherwise, analysis with the anti-ETR1(165–400) antibody was performed on proteins that were not treated with DTT. Immunodecorated proteins were visualized by enhanced chemiluminescence detection according to the manufacturer (Pierce Chemical, Rockford, IL).

For the results shown in Figure 6, the polyclonal anti-ETR1(165–400) serum was affinity purified. This was done to remove antibodies that cross-reacted with Arabidopsis polypeptides of similar molecular mass to the reduced forms of the full-length and truncated receptors. The anti-ETR1(165–400) serum was depleted of antibodies that cross-react with GST by passing through a column of Affigel-10 cross-linked to GST. The serum was then affinity purified with Affigel-10 columns cross-linked to GST-ETR1(165–400) (Schaller et al., 1995). Antibodies were eluted with 100 mM Gly, pH 2.5, neutralized with 1 M Tris, pH 8.0, and dialyzed against phosphate-buffered saline. Cross-linking to Affigel-10 was performed according to the manufacturer (Bio-Rad Laboratories, Hercules, CA).

Plant Physiol. Vol. 128, 2002

### ACKNOWLEDGMENTS

We thank Estelle Hrabak and John Collins for critical reading of the manuscript before publication.

Received August 23, 2001; returned for revision November 16, 2001; accepted January 11, 2002.

### LITERATURE CITED

- Abeles FB, Morgan PW, Saltveit ME Jr (1992) Ethylene in Plant Biology, Ed 2. Academic Press, San Diego
- Aravind L, Ponting CP (1997) The GAF domain: an evolutionary link between diverse phototransducing proteins. *Trends Biochem Sci* 22: 458–459
- Bent AF, Clough SJ (1998) Agrobacterium germ-line transformation: transformation of Arabidopsis without tissue culture. In SB Gelvin, RA Schilperout, eds, *Plant Molecular Biology Manual*, Ed 2. Kluwer Academic Publishers, Dordrecht, The Netherlands, pp 1–14
- Bevan M (1984) Binary Agrobacterium vectors for plant transformation. *Nucleic Acids Res* 12: 8711–8721
- Bilwes AM, Alex LA, Crane BR, Simon MI (1998) Structure of CheA, a signal-transducing histidine kinase. *Cell* 96: 131–141
- Bleecker AB (1999) Ethylene perception and signaling: an evolutionary perspective. *Trends Plant Sci* 4: 269–274
- Bleecker AB, Estelle MA, Somerville C, Kende H (1988) Insensitivity to ethylene conferred by a dominant mutation in Arabidopsis thaliana. *Science* 241: 1086–1089
- Bray D, Levin MD, Morton-Firth CJ (1998) Receptor clustering as a cellular mechanism to control sensitivity. *Nature* 393: 85–88
- Chang C, Kwok SF, Bleecker AB, Meyerowitz EM (1993) Arabidopsis ethylene response gene ETR1: Similarity of product to two-component regulators. *Science* 262: 539–544
- Chang C, Meyerowitz EM (1995) The ethylene hormone response in Arabidopsis: a eukaryotic two component signaling system. *Proc Natl Acad Sci USA* 92: 4129–4133
- Chang C, Shockey JA (1999) The ethylene-response pathway: signal perception to gene regulation. *Curr Opin Plant Biol* 2: 352–358
- Chen QG, Bleecker AB (1995) Analysis of ethylene signal transduction kinetics associated with seedling-growth responses and chitinase induction in wild-type and mutant Arabidopsis. *Plant Physiol* 108: 597–607
- Clark KL, Larsen PB, Wang X, Chang C (1998) Association of the Arabidopsis CTR1 Raf-like kinase with the ETR1 and ERS1 ethylene receptors. *Proc Natl Acad Sci USA* 95: 5401–5406
- Duclos B, Marcandier S, Cozzone AJ (1991) Chemical properties and separation of phosphoamino acids by thin-layer chromatography and/or electrophoresis. *Methods Enzymol* 201: 10–21
- Gamble RL, Coonfield ML, Schaller GE (1998) Histidine kinase activity of the ETR1 ethylene receptor from Arabidopsis. *Proc Natl Acad Sci USA* 95: 7825–7829
- Guzmán P, Ecker JR (1990) Exploiting the triple response of Arabidopsis to identify ethylene-related mutants. *Plant Cell* 2: 513–523

1437

- Hall AE, Chen QG, Findell JL, Schaller GE, Bleecker AB (1999) The relationship between ethylene binding and dominant insensitivity conferred by mutant forms of the ETR1 ethylene receptor. *Plant Physiol* 121: 291–299
- Hua J, Chang C, Sun Q, Meyerowitz EM (1995) Ethylene sensitivity conferred by Arabidopsis ERS gene. *Science* 269: 1712–1714
- Hua J, Meyerowitz EM (1998) Ethylene responses are negatively regulated by a receptor gene family in Arabidopsis thaliana. *Cell* 94: 261–271
- Hua J, Sakai H, Nourizadeh S, Chen QG, Bleecker AB, Ecker JR, Meyerowitz EM (1998) EIN4 and ERS2 are members of the putative ethylene receptor family in Arabidopsis. *Plant Cell* 10: 1321–1332
- Kieber JJ, Rothenberg M, Roman G, Feldman KA, Ecker JR (1993) CTR1, a negative regulator of the ethylene response pathway in Arabidopsis, encodes a member of the Raf family of protein kinases. *Cell* 72: 427–441
- Klimyuk VI, Carroll BJ, Thomas CM, Jones JDG (1993) Alkali treatment for the rapid preparation of plant material for reliable PCR analysis. *Plant J* 3: 493–494
- Knight LI, Rose RC, Crocker W (1910) Effects of various gases and vapors upon etiolated seedlings of the sweet pea. *Science* 31: 635–636
- Laemmli UK (1970) Cleavage of structural proteins during the assembly of the head of bacteriophage T4. *Nature* 227: 680–685
- Mitchell DA, Marshall TK, Deschenes RJ (1993) Vectors for inducible overexpression of glutathione S-transferase fusion proteins in yeast. *Yeast* 9: 715–723
- Muller-Dieckmann HJ, Grantz AA, Kim SH (1999) The structure of the signal receiver domain of the Arabidopsis thaliana ethylene receptor ETR1. *Struct Fold Des* 7: 1547–1556
- Pan SQ, Charles T, Jin S, Wu Z-L, Nester EW (1993) Preformed dimeric state of the sensor protein VirA is involved in plant-Agrobacterium signal transduction. *Proc Natl Acad Sci USA* 90: 9939–9943
- Parkinson JS (1993) Signal transduction schemes of bacteria. *Cell* 73: 857–871
- Rodriguez FI, Esch JJ, Hall AE, Binder BM, Schaller GE, Bleecker AB (1999) A copper cofactor for the ethylene receptor ETR1 from Arabidopsis. *Science* 283: 996–998
- Sakai H, Hua J, Chen QG, Chang C, Medrano LJ, Bleecker AB, Meyerowitz EM (1998) ETR2 is an ETR1-like gene involved in ethylene signaling in Arabidopsis. *Proc Natl Acad Sci USA* 95: 5812–5817
- Schaller GE (2000) Histidine kinases and the role of two-component systems in plants. *Adv Bot Res* 32: 109–148
- Schaller GE, Bleecker AB (1995) Ethylene-binding sites generated in yeast expressing the Arabidopsis ETR1 gene. *Science* 270: 1809–1811
- Schaller GE, DeWitt ND (1995) Analysis of the H<sup>+</sup>-ATPase and other proteins of the Arabidopsis plasma membrane. *Methods Cell Biol* 50: 129–148
- Schaller GE, Ladd AN, Lanahan MB, Spanbauer JM, Bleecker AB (1995) The ethylene response mediator ETR1 from Arabidopsis forms a disulfide-linked dimer. *J Biol Chem* 270: 12526–12530
- Stock JB, Surette MG, Levit M, Park P (1995) Two-component signal transduction systems: structure-function relationships and mechanisms of catalysis. In JA Hoch, TJ Silhavy, eds, *Two-Component Signal Transduction*. American Society for Microbiology, Washington, DC, pp 25–51
- Tieman DM, Klee HJ (1999) Differential expression of two novel members of the tomato ethylene-receptor family. *Plant Physiol* 120: 165–172
- Tieman DM, Taylor MG, Ciardi JA, Klee HJ (2000) The tomato ethylene receptors NR and LeETR4 are negative regulators of ethylene response and exhibit functional compensation within a multigene family. *Proc Natl Acad Sci USA* 97: 5663–5668
- van Hoof A, Green PJ (1996) Premature nonsense codons decrease the stability of phytohemagglutinin mRNA in a position-dependent manner. *Plant J* 10: 415–424
- Wilkinson JQ, Lanahan MB, Clark DG, Bleecker AB, Chang C, Meyerowitz EM, Klee HJ (1997) A dominant mutant receptor from Arabidopsis confers ethylene insensitivity in heterologous plants. *Nature Biotechnol* 15: 444–447
- Yang Y, Inouye M (1993) Requirement of both kinase and phosphatase activities of an E. coli receptor (Taz1) for ligand-dependent signal transduction. *J Mol Biol* 231: 335–342

## APPENDIX 2

# Effect of Ethylene Pathway Mutations upon Expression of the Ethylene Receptor ETR1 from Arabidopsis<sup>1</sup>

Xue-Chu Zhao<sup>2</sup>, Xiang Qu<sup>2</sup>, Dennis E. Mathews, and G. Eric Schaller\*

Departments of Biochemistry and Molecular Biology (X.-C.Z., X.Q., G.E.S.) and Plant Biology (D.E.M.), University of New Hampshire, Durham, New Hampshire 03824

The ethylene receptor family of Arabidopsis consists of five members, one of these being ETR1. The effect of ethylene pathway mutations upon expression of ETR1 was examined. For this purpose, ETR1 levels were quantified in mutant backgrounds containing receptor loss-of-function mutations, ethylene-insensitive mutations, and constitutive ethylene response mutations. Ethylene-insensitive mutations of ETR1 resulted in a posttranscriptional increase in levels of the mutant receptor. Treatment of seedlings with silver, which leads to ethylene insensitivity, also resulted in an increase in levels of ETR1. Loss-of-function mutations of ETR1 resulted in both transcriptional and posttranscriptional changes in levels of the receptor. Most other ethylene pathway mutations, including a newly isolated T-DNA insertion mutation in the gene encoding the ethylene receptor ERS1, had relatively minor effects upon the expression of ETR1. Our results indicate that mutations in ETR1 can affect expression at the posttranscriptional level, and suggest that these posttranscriptional changes may contribute to the phenotypes observed in the mutants. Our results also refine the model on how mutations in ethylene receptors are able to confer dominant ethylene insensitivity upon plants.

Ethylene (C<sub>2</sub>H<sub>4</sub>) is a simple gaseous hydrocarbon that has profound effects upon plant growth and development. Ethylene regulates seed germination, seedling growth, leaf and petal abscission, organ senescence, ripening, stress responses, and pathogen responses (Mattoo and Suttle, 1991; Abeles et al., 1992). An important contribution to our understanding of ethylene signal transduction has come from the identification of mutants in Arabidopsis with altered ethylene sensitivity (Chang and Shockey, 1999; Stepanova and Ecker, 2000). These mutations fall into two main classes: (a) mutations that render a plant insensitive to ethylene, and (b) mutations that result in a constitutive ethylene response. Characterization of Arabidopsis mutants has led to the identification of ethylene receptors and additional components in the ethylene signal transduction pathway.

The ethylene receptor family of Arabidopsis contains five members (ETR1, ETR2, ERS1, ERS2, and EIN4; Schaller, 2000; Chang and Stadler, 2001), with ethylene binding confirmed for ETR1 and ERS1 (Schaller and Bleeker, 1995; Rodriguez et al., 1999; Hall et al., 2000). The receptors contain three N-terminal transmembrane domains that encompass the ethylene-binding site (Schaller and Bleeker, 1995; Rodriguez et al., 1999). The binding site contains a cop-

per cofactor that is required for the high-affinity ethylene binding that receptors display (Rodriguez et al., 1999). In the C-terminal half, the receptors contain regions with similarity to His kinases and, in some cases, the receiver domains of response regulators (Schaller, 2000; Chang and Stadler, 2001), signaling elements originally identified as parts of bacterial two-component systems (Parkinson, 1993; Schaller, 2000). His kinase activity has been confirmed in vitro for ETR1 (Gamble et al., 1998), but the role of this activity in signal output is still unclear (Gamble et al., 2002).

Mutations in the ethylene receptors can result in ethylene insensitivity or constitutive ethylene responses, dependent on the nature of the mutation. Ethylene insensitivity can result from single amino acid changes within the region of the receptor involved in ethylene binding (Chang et al., 1993; Hua et al., 1995, 1998; Sakai et al., 1998). Evidence indicates that these gain-of-function mutations either disrupt ethylene binding or uncouple ethylene binding from signal output (Schaller and Bleeker, 1995; Hall et al., 1999; Rodriguez et al., 1999). For example, the *etr1-1* mutation abolishes the ability of the receptor to coordinate the copper cofactor, and as a consequence, eliminates ethylene binding (Rodriguez et al., 1999). The ethylene-insensitive mutations are dominant and a single mutation in any one of the five family members can confer ethylene insensitivity upon the plant.

Loss-of-function mutations have been identified in four of five members of the ethylene receptor family (Hua and Meyerowitz, 1998). Single loss-of-function mutations have little or no effect upon ethylene signal transduction. However, in combination with the ETR1 loss-of-function mutation, the mutants show constitutive ethylene responses and this effect is most

<sup>1</sup> This work was supported by the National Science Foundation (grant nos. MCB-9982510 and DBI-9975908 to G.E.S.). This is scientific contribution no. 2,138 from the New Hampshire Agricultural Experiment Station.

<sup>2</sup> These authors contributed equally to the paper.

\* Corresponding author; e-mail [egs@clsunlx.unh.edu](mailto:egs@clsunlx.unh.edu); fax 603-862-4013.

Article, publication date, and citation information can be found at [www.plantphysiol.org/cgi/doi/10.1104/pp.011635](http://www.plantphysiol.org/cgi/doi/10.1104/pp.011635).

pronounced in triple and quadruple loss-of-function mutations (Hua and Meyerowitz, 1998). These results indicate that there is functional overlap among the receptor family members. These results also indicate that the receptors serve as negative regulators of the ethylene response pathway because elimination of receptors activates ethylene responses. According to this model for negative regulation, wild-type ethylene receptors actively repress ethylene responses in the air. In the presence of ethylene, wild-type receptors switch to a signaling inactive state that allows for induction of ethylene responses. Ethylene-insensitive mutant receptors, such as *etr1-1*, are apparently locked into the signaling state that they have in air, such that they repress ethylene responses even in the presence of ethylene (Bleecker, 1999).

Additional elements involved in ethylene signal transduction have also been identified by mutational analysis in *Arabidopsis*. RAN1 is a copper-transporting ATPase apparently required for addition of the copper cofactor to the ethylene receptors (Hirayama et al., 1999; Woeste and Kieber, 2000). Mutations in RAN1 alter ethylene signal transduction, a loss-of-function mutation resulting in a constitutive ethylene response. CTR1, EIN2, and EIN3 are all thought to act in the same primary response pathway and act downstream of the ethylene receptors. CTR1 belongs to the Raf family of protein Ser/Thr kinases that initiate mitogen-activated protein kinase cascades in eukaryotes (Kieber et al., 1993) and has been shown capable of physical interaction with the ethylene receptors ETR1 and ERS1 (Clark et al., 1998). Loss-of-function mutations in CTR1 result in constitutive ethylene responses (Kieber et al., 1993). EIN2 is an integral membrane protein with similarity to the Nramp family of metal ion transporters (Alonso et al., 1999). Loss-of-function mutations in EIN2 result in ethylene insensitivity. EIN3 belongs to a family of transcription factors that are directly activated by the ethylene signal transduction system and are required for ethylene-dependent gene induction (Chao et al., 1997). Loss-of-function mutations in EIN3 render a plant ethylene insensitive.

Here, we analyze the effect of ethylene pathway mutations upon expression of the ethylene receptor ETR1. This analysis was facilitated by the following: (a) the availability of a number of mutations within the receptor itself, thereby providing independent verification for effects of these mutations; (b) the availability of an antibody against ETR1, thereby allowing for analysis at the protein level; and (c) a detectable basal level of expression for ETR1, thereby allowing increases and decreases in expression to be determined. Our results lend insight into how ethylene receptor mutations affect expression and indicate that mutations within ETR1 can result in posttranscriptional changes in its own expression level. Our results also lend insight into the mechanism by

which mutations within the receptors can lead to dominant ethylene insensitivity.

RESULTS

Effect of Ethylene Insensitivity Conferring Mutations upon Expression of ETR1

Four dominant mutations have been isolated in ETR1 that confer ethylene insensitivity on plants. These mutations, designated *etr1-1*, *etr1-2*, *etr1-3*, and *etr1-4*, all result in single amino acid changes within the hydrophobic domain of ETR1 that has been implicated in ethylene binding (Fig. 1A; Chang et al., 1993). The *etr1-1*, *etr1-3*, and *etr1-4* mutations either reduce or eliminate ethylene binding (Hall et al., 1999). The *etr1-2* mutation does not disrupt ethylene binding, but apparently uncouples ethylene binding

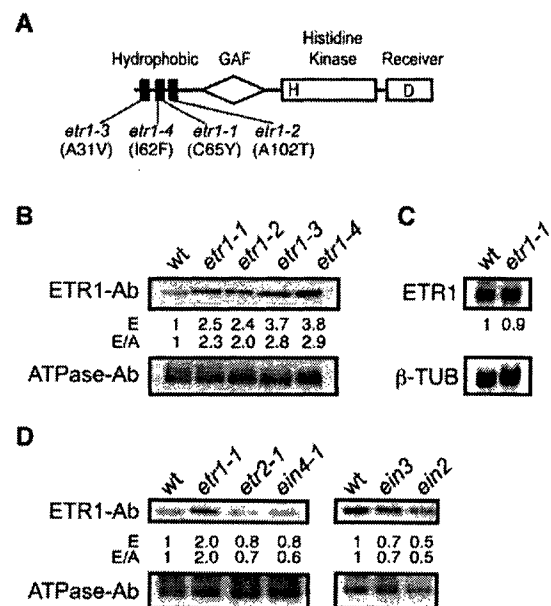

Figure 1. Effect of ethylene-insensitivity mutations upon expression of ETR1. A, Structure of ETR1 and position of ethylene-insensitive mutations. The hydrophobic ethylene-sensing domain, the GAF domain, the His kinase domain, and the receiver domain are indicated. The letters H and D indicate putative phosphorylation sites. B, Immunoblot analysis of wild-type and ethylene-insensitive mutants of ETR1. Etiolated seedlings were grown for 4 d, and the level of immunodetectable full-length receptor then determined from 10 g of membrane proteins using an antibody directed against ETR1. Expression levels were quantified densitometrically (E) and also normalized against immunologically determined levels of the H-ATPase (E/A) as an internal control. C, Northern blot analysis of mRNA obtained from wild-type and *etr1-1* seedlings. Blots were probed with an ETR1 probe and a  $\beta$ -tubulin gene probe as an internal control. The numbers represent the expression level of the ethylene receptor gene after normalization for the level of  $\beta$ -tubulin expression. D, Immunoblot analysis of ETR1 levels in additional ethylene-insensitive mutant backgrounds.



from signal output (Hall et al., 1999). Based on immunoblot analysis, the protein levels of the mutant receptors *etr1-1*, *etr1-2*, *etr1-3*, and *etr1-4* were all approximately 2- to 3-fold higher than that of the wild-type receptor ETR1 when analyzed in etiolated seedlings (Fig. 1B). To determine if the effect upon expression occurred at the transcriptional or post-transcriptional level, transcript levels of the receptor were determined by northern blot in both wild-type and *etr1-1* backgrounds (Fig. 1C). No difference in transcript levels was found for the receptor between wild type and *etr1-1*. However, as previously observed (Fig. 1B), we did find that the *etr1-1* protein was present at 2-fold higher levels than the ETR1 protein when analyzed by immunoblot using a portion of the same plant material examined by northern blot (results not shown). Thus, the increase in expression of ethylene-insensitive mutations of ETR1 occurs at the posttranscriptional level.

To determine if increased expression of the receptor was restricted to mutant lesions in ETR1 or was a general feature of ethylene insensitivity in Arabidopsis, we examined other ethylene-insensitive mutations. Seedlings were examined that contained dominant ethylene-insensitive mutations in other ethylene receptors (*etr2-1* and *ein4-1*). Seedlings were also examined that contained ethylene-insensitive mutations in the downstream ethylene signaling components EIN2 and EIN3. The expression level of ETR1 based on immunoblot in these other mutant backgrounds was comparable with or less than that found in the wild-type background (Fig. 1D). Thus, the increased expression of ethylene-insensitive mutants of ETR1 is restricted to those lesions present in ETR1 itself, rather than being a general feature of ethylene-insensitive mutations.

Some chemical compounds are able to induce ethylene insensitivity in plants by interacting with the ethylene receptors. Silver is thought to replace the copper cofactor present in the ethylene-binding site of the receptor. Receptors containing silver are still able to bind ethylene but the binding site is apparently perturbed such that ethylene binding is uncoupled from signal output (Rodriguez et al., 1999). We hypothesized that binding of silver by an ethylene receptor might mimic the effect of an ethylene-insensitive mutation in that receptor, and result in an increased expression level of the receptor. Consistent with this hypothesis, we observed that wild-type seedlings treated with  $10 \mu\text{g mL}^{-1}$  silver nitrate had higher levels of ETR1 than control untreated seedlings based upon immunoblot analysis (Fig. 2). The stimulatory effect of silver upon expression was lacking with ethylene-insensitive mutations of ETR1 (Fig. 2). This supports the hypothesis that silver mimics the effect of the ethylene-insensitive mutation because there is no additive effect of silver on expression of the ethylene-insensitive mutants.

Plant Physiol. Vol. 130, 2002



Figure 2. Effect of silver treatment upon expression of ETR1. Wild-type and *etr1* mutant seedlings were grown in the presence or absence of  $10 \mu\text{g mL}^{-1}$  silver nitrate (Ag). Immunoblot analysis was then performed using antibodies directed against ETR1 and the H<sup>+</sup>-ATPase as an internal control on 10 g of membrane protein. Expression levels are given based directly upon that determined with anti-ETR1 antibody (E) and normalized against the ATPase levels (E/A). For each plant background, expression level of the receptor in the presence of silver is given relative to that observed in the absence of silver. Results from two independent experimental treatments of wild-type plants with silver are shown.

#### Effect of Loss-of-Function Mutations in ETR1 upon its Expression

The mutations *etr1-5*, *etr1-6*, *etr1-7*, and *etr1-8* are all loss-of-function mutations in ETR1 (Hua and Meyerowitz, 1998). The mutations *etr1-5*, *etr1-6*, and *etr1-7* were isolated as intragenic suppressors of the ethylene insensitivity conferred by *etr1-1*, whereas *etr1-8* was isolated as an intragenic suppressor of *etr1-2* (Fig. 3A). The *etr1-5*, *etr1-6*, and *etr1-8* mutations all introduce premature stop codons into the coding sequence. The *etr1-6* mutation occurs at an intron splice site and retention of that intron would introduce a premature stop codon. All four mutants show similar ethylene responsiveness to that of wild-type plants (Hua and Meyerowitz, 1998). To determine whether the mutations result in the absence of the receptor or produce a truncated receptor incapable of signaling, we analyzed receptor expression by immunoblot. Two different antibodies, anti-ETR1(165–400) and anti-ETR1(401–738), were used that are targeted against different regions of the receptor (Fig. 3A). In initial experiments using recombinant fusion proteins expressed in bacteria, we confirmed that both antibodies recognized the *etr1-5* and *etr1-8* truncations as efficiently as full-length ETR1, and that they were incapable of detecting the *etr1-6* truncation (results not shown). When Arabidopsis membranes were analyzed by immunoblot, no full-length protein was detected for any of the loss-of-function mutants (Fig. 3B). In addition, we did not detect any immunoreactive bands that would correspond to the truncated receptors. Note that the anti-ETR1(165–400) antibody does cross-react with a protein of 68 kD, but this is not derived from ETR1. A truncated protein for *etr1-5* and *etr1-8* would be detectable with both the anti-ETR1(165–400) and anti-ETR1(401–738) antibodies. Based on a control dilution series of the receptor, the anti-ETR1(165–400) antibody was capable of detecting a protein expressed at 10% of the level found with the wild-type receptor ETR1 or 5% of the level found with *etr1-1*. The anti-ETR1(401–738) antibody is even

1985

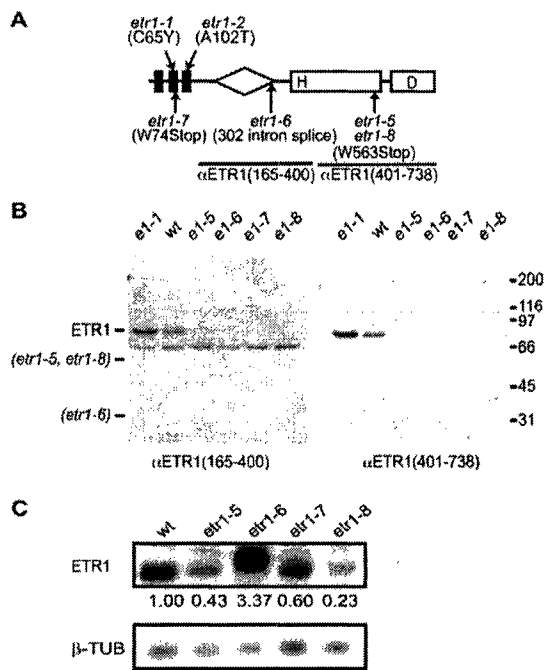

Figure 3. Effect of loss-of-function mutations in ETR1 upon its expression. A, Positions of mutations in ETR1. The positions of ethylene-insensitive mutations are shown above the diagram of ETR1. The positions of intragenic suppressors of these mutations that result in loss of function are shown below the diagram of ETR1. Positions of regions used to generate the anti-ETR1(165–400) and anti-ETR1(401–738) antibodies are also indicated. B, Immunoblot analysis of ETR1 in different loss-of-function backgrounds. Membrane fractions (10 g) from etiolated Arabidopsis seedlings were analyzed by immunoblot using the anti-ETR1(165–400) and anti-ETR1(401–738) antibodies. The migration position of ETR1 and predicted migration positions of the *etr1-5*, *etr1-6*, and *etr1-8* truncated receptors are indicated on the left. Migration positions of molecular mass markers are indicated on the right in kilodaltons. C, Transcript levels of ETR1 in different loss-of-function backgrounds. Blots of mRNA were probed with an ETR1 probe and a  $\beta$ -tubulin gene probe as an internal control. The numbers represent the expression level of the ethylene receptor gene after normalization for the level of  $\beta$ -tubulin gene expression.

more sensitive and is capable of detecting proteins with at least 2-fold higher sensitivity than that of the anti-ETR1(165–400) antibody.

The lack of detectable protein for the *etr1-5* and *etr1-8* loss-of-function mutants could be because of instability of the truncated protein or of the mRNA. To differentiate between these possibilities, we performed northern-blot analysis. Transcripts were detected for all the loss-of-function mutations in ETR1 (Fig. 3C). The transcript for *etr1-6* is slightly larger than the other transcripts, as predicted, because of the presence of an unspliced intron. Compared with wild type, the mRNA levels of *etr1-5* and *etr1-8* were reduced approximately 2- or 4-fold, respectively,

whereas the mRNA level of *etr1-6* was increased about 3-fold. The reduction in mRNA levels of *etr1-5* and *etr1-8* is significant but not sufficient to explain the lack of detectable protein, indicating that post-transcriptional mechanisms may also play a role in reducing the levels of the truncated proteins.

#### Effect of Loss-of-Function Mutations in Other Ethylene Receptors upon Expression of ETR1

Loss of one member in a gene family can sometimes lead to functional compensation, whereby expression of another member of the same gene family is induced to compensate for activity of the missing family member (Bérard et al., 1997; Mulligan et al., 1998; Minkoff et al., 1999). An intriguing set of experiments suggests that functional compensation occurs within the ethylene receptor family of tomato (Tieman et al., 2000). Therefore, we examined the Arabidopsis ethylene receptor ETR1 to determine if its expression was affected by loss-of-function mutations in other ethylene receptor family members. Analysis was performed on single loss-of-function mutants (*etr2-3* and *ein4-4*), a double mutant (*etr2-3; ein4-4*), and a triple mutant (*etr2-3; ein4-4; ers2-3*; Hua and Meyerowitz, 1998). The single mutants have little effect upon growth of etiolated Arabidopsis seedlings, but seedlings containing the double and triple mutant demonstrate partial induction of the triple-response phenotype, consistent with loss of receptors activating the ethylene response pathway (Fig. 4; Hua and Meyerowitz, 1998). The expression level of ETR1 protein in these mutant backgrounds was comparable with that found in the wild-type background (Fig. 4), indicating that ETR1 did not functionally compensate for the loss of these other members of the receptor family.

The ethylene receptor ERS1 is more closely related at the sequence level to ETR1 than are the other ethylene receptors of Arabidopsis (Chang and Stadler, 2001), but no loss-of-function mutations have been available for ERS1 (Hua and Meyerowitz, 1998). We isolated a T-DNA insertion in ERS1 by use of a PCR-based strategy, and determined by sequencing from the left-border junction that the T-DNA was inserted into the 5'-untranslated region of ERS1 (Fig. 5A). Sequence at the T-DNA junction with ERS1 was ATA-ACGCTCGGATCAATCA tactcga(atattcaattgtaaatggct), with capitals indicating ERS1 sequence and parentheses indicating T-DNA left border sequence. We named this mutant allele *ers1-2* to differentiate it from the previously characterized ethylene-insensitive *ers1-1* mutation (Hua et al., 1995). The responsiveness to ethylene of plants homozygous for the *ers1-2* mutation was similar to that of wild-type plants (Fig. 5B). However, a double mutant of *ers1-2* with the *etr1-7* loss-of-function mutant displayed a strong ethylene response phenotype when grown in the absence of ethylene (Fig. 5C). Dark-grown *ers1-2; etr1-7* seedlings

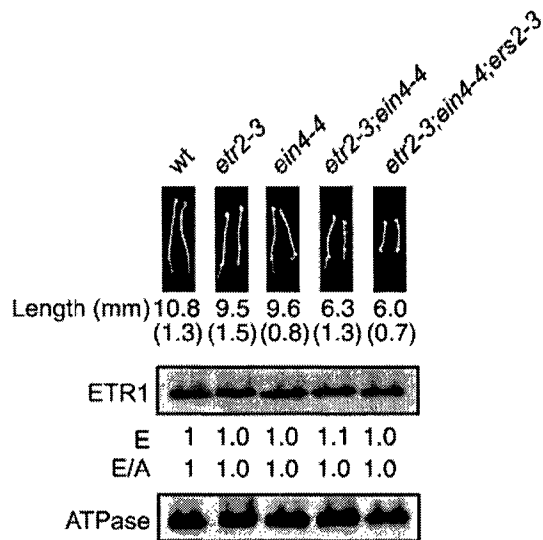

Figure 4. Effect of loss-of-function mutations in ETR2, EIN4, and ERS2 upon expression of ETR1. The phenotypes of 4-d-old dark-grown seedlings containing single, double, and triple mutant combinations of *etr2-3*, *ein4-4*, and *ers2-3* are shown. The mean hypocotyl length is given in millimeters based on measurement of at least 25 seedlings with the *sd* in parentheses. Immunoblot analysis was performed using antibodies directed against ETR1 and the H<sup>+</sup>-ATPase as an internal control on 10  $\mu$ g of membrane protein. Expression levels are given based directly upon that determined with anti-ETR1 antibody (E) and normalized against the ATPase levels (E/A).

displayed a triple-response phenotype in the air. Light-grown *ers1-2;etr1-7* plants were dwarfed with compact and epinastic leaves in the air and died without bolting. Northern-blot analysis indicated a substantial reduction in mRNA levels of *ers1-2* compared with that found in wild type, but low levels of transcript were detected (Fig. 5D). The significant reduction of ERS1 transcript levels in the *ers1-2* mutant would contribute to the strong mutant phenotype observed when the *ers1-2* mutant is combined with the *etr1-7* mutant. The lack of a mutant phenotype in the *ers1-2* mutant by itself could potentially be explained by functional compensation, ETR1 being a possible candidate because of its sequence similarity. However, the expression of ETR1 in the *ers1-2* mutant background was comparable with that found in the wild-type background at both the mRNA and protein levels (Fig. 5, D and E), indicating that functional compensation was not because of changes in ETR1 expression.

#### Effect of mutations in RAN1 and CTR1 upon Expression of ETR1

RAN1 is a copper-transporting ATPase implicated in the delivery of the copper cofactor to the ethylene receptors (Hirayama et al., 1999; Woeste and Kieber,

2000). The *ran1-1* and *ran1-2* mutations cause single amino acid changes in the RAN1 protein and are thought to alter rather than eliminate function (Hirayama et al., 1999). Plants containing these mutations demonstrate an induction of ethylene responses when treated with trans-cyclooctene, normally an antagonist of ethylene responses, but have no other discernible effect upon growth (Hirayama et

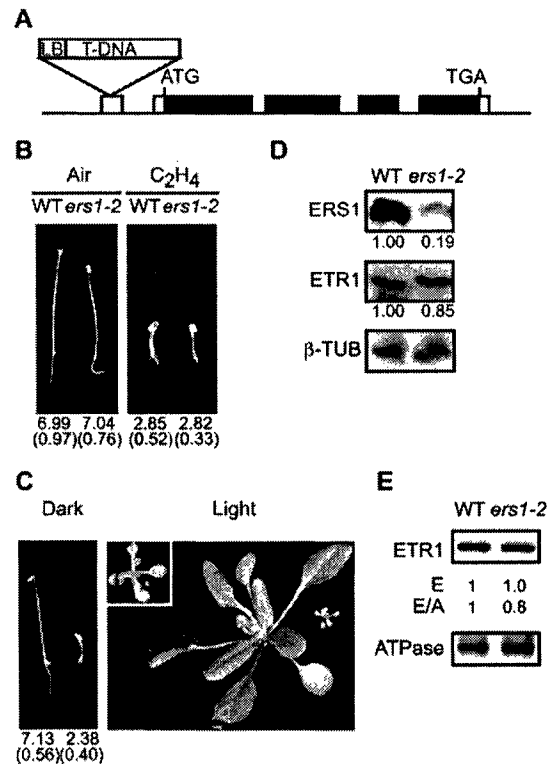

Figure 5. Analysis of the T-DNA insertional mutant *ers1-2*. A, Location of T-DNA insertion in the ERS1 gene. Black bars and white bars represent translated and untranslated regions of the ERS1 transcript, respectively. B, Phenotype of 3.5-d-old dark-grown seedlings containing the *ers1-2* mutation grown in air or ethylene (50  $\mu$  L L<sup>-1</sup>). Mean hypocotyl lengths are given in millimeters with *sd* in parentheses. C, Phenotype of the *ers1-2;etr1-7* double mutant as compared with seedlings with wild-type phenotype segregating from the same population. Seedlings were grown in dark for 3.5 d or in the light for 4 weeks. The *ers1-2;etr1-7* double mutant is on the right in each panel, and a 2-fold enlargement is also inset to reveal details of the light-grown seedling. D, Northern-blot analysis of ERS1 and ETR1 expression in the *ers1-2* mutant line performed using 25  $\mu$ g of total RNA. The numbers represent the expression level of the ethylene receptor genes after normalization for the level of  $\beta$ -tubulin expression. E, Effect of the *ers1-2* mutation upon expression of ETR1 in etiolated seedlings. Immunoblot analysis was performed using antibodies directed against ETR1 and the H<sup>+</sup>-ATPase as an internal control on 15  $\mu$ g of membrane protein. Expression levels are given based directly upon that determined with anti-ETR1 antibody (E) and normalized against the ATPase levels (E/A).

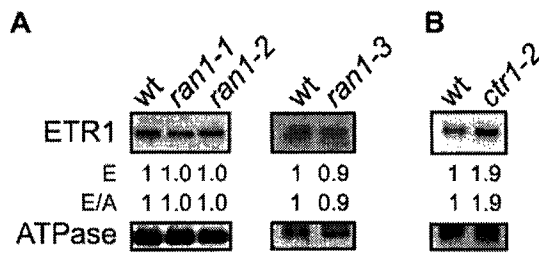

Figure 6. Effect of mutations in RAN1 and CTR1 upon expression of ETR1. Immunoblot analysis was performed using antibodies directed against ETR1 and the H<sup>+</sup>-ATPase as an internal control. Expression levels are given based directly upon that determined with anti-ETR1 antibody (E) and normalized against the ATPase levels (E/A). A, Effect of ran1 mutations on expression of ETR1. For ran1-1 and ran1-2, etiolated seedlings were examined; for ran1-3, leaves of 4-week-old plants were examined. B, Effect of the ctr1-2 mutation upon expression of ETR1 in etiolated seedlings.

al., 1999). Both ran1-1 and ran1-2 seedlings expressed ETR1 at levels similar to wild-type seedlings (Fig. 6A). The loss-of-function mutation ran1-3 results in constitutive activation of the ethylene response pathway. Because ran1-3 plants produce leaves but die without bolting (Woeste and Kieber, 2000), we identified homozygous ran1-3 plants based on phenotype from a segregating population of 4-week-old plants grown in the light. We observed no difference in ETR1 levels in ran1-3 plants compared with wild-type plants or members of the segregating population that lacked the ran1-3 phenotype (Fig. 6A). Loss-of-function mutations in the Ser/Thr kinase CTR1 also result in constitutive ethylene responses. We typically observed about a 2-fold increase in levels of ETR1 in the ctr1-2 mutant background relative to wild type (Fig. 6B). This could arise because of a low level of ethylene inducibility for the ETR1 transcript (Hua et al., 1998) or be an indirect effect of the phenotypic differences between ctr1-2 and wild-type plants (Kieber et al., 1993).

DISCUSSION

Expression of the ethylene receptor ETR1 was sensitive to mutations within its own coding sequence. Both gain-of-function mutations and loss-of-function mutations affected expression of ETR1 at the post-transcriptional level and, as discussed below, these posttranscriptional changes could contribute to the phenotypes observed in the mutants. Expression of ETR1 was affected to only a limited extent by mutations in other pathway components. For instance, loss-of-function mutations in other members of the ethylene receptor family had little effect upon expression of ETR1, indicating that ETR1 does not functionally compensate for the loss of these receptors by an increase in its own expression.

Expression analysis of ethylene pathway mutations refines the model shown in Figure 7 on how ethylene

insensitivity is conferred by mutant forms of ETR1. Each of the four ethylene-insensitive mutations of ETR1 results in increased protein levels of the receptor, apparently through a posttranscriptional mechanism. The effect upon receptor expression can be phenocopied at the molecular level by treatment of plants with silver, which is also capable of generating ethylene insensitivity in plants. Both the ethylene-insensitive mutations (Hall et al., 1999) and silver (Rodriguez et al., 1999) are thought to perturb the ethylene-binding site (Fig. 7), and thus ethylene perception may play a role in regulating expression of the receptor. The ethylene-insensitive forms of the receptor could potentially have a slower rate of turnover than the wild-type receptors because turnover of animal hormone receptors is commonly regulated by ligand binding (Wiley, 1992). In such a case, endogenous ethylene levels within the plant would have to be sufficient to result in differing rates of turnover for the wild-type and mutant receptors.

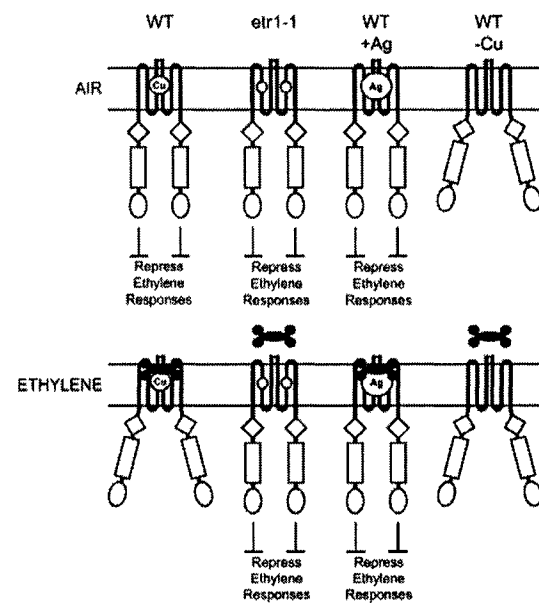

Figure 7. A model for signaling by wild-type and mutant versions of the ethylene receptor ETR1. The ethylene receptor ETR1 contains one ethylene-binding site per homodimer, with ethylene binding mediated by a single copper ion (Cu) present in the ethylene-binding site. In air, wild-type (WT) receptors actively repress ethylene responses. In ethylene, wild-type receptors are inactivated, thereby relieving repression of the ethylene response pathway. The etr1-1 mutation (indicated by a white circle) eliminates binding of the copper cofactor and locks the receptor into a conformation such that the receptor represses ethylene responses even in the presence of ethylene. The replacement of the copper cofactor by silver (WT + Ag) also serves to lock the receptor into a conformation such that it continuously represses ethylene responses. In contrast, elimination of the copper cofactor (WT - Cu) results in the receptor adapting an inactive conformation in air and ethylene.

The discovery that ethylene-insensitive mutants of ETR1 have a higher expression level than wild-type receptors helps resolve an apparent paradox in our understanding of signaling by ethylene receptors (Hua and Meyerowitz, 1998; Bleecker, 1999; Chang and Stadler, 2001). An ethylene-insensitive mutation in one member of the five-member ethylene receptor family is sufficient to confer ethylene insensitivity, suggesting that signaling by one family member is enough to repress ethylene responses. On the other hand, loss-of-function mutations in three receptors simultaneously are sufficient to induce ethylene responses (Hua and Meyerowitz, 1998), a situation under which two family members would still theoretically be signaling to repress ethylene responses. Our data indicate that the signal output by an ethylene-insensitive receptor mutant is not equivalent to that of a wild-type receptor because of the difference in expression levels. The increase in expression of the ethylene-insensitive mutants of ETR1 would result in an increase in signal output and the ability to repress ethylene responses. Other mechanisms may also increase signal output of the ethylene-insensitive mutant receptors, such as their postulated ability to convert wild-type receptors to an ethylene-insensitive signaling state via heteromeric interactions (Chang and Stadler, 2001; Gamble et al., 2002).

Analysis of ETR1 expression in the *ran1-3* background further clarifies the mechanism by which mutations in ethylene receptors confer ethylene insensitivity. The *ran1-3* mutant eliminates a copper transporter required for delivery of the copper cofactor to the ethylene receptors (Hirayama et al., 1999; Woeste and Kieber, 2000). Plants containing the *ran1-3* mutation display a constitutively active ethylene response (Woeste and Kieber, 2000). Interestingly, mutations like *etr1-1* that produce a receptor unable to bind the copper cofactor result in the opposite phenotype: ethylene insensitivity (Rodriguez et al., 1999). This difference in phenotypes could be because of: (a) destabilization of the ethylene receptors in the *ran1-3* background, or (b) functional differences between receptors lacking copper and the ethylene-insensitive receptor mutations. Our data support the second hypothesis. ETR1 protein was detected in the *ran1-3* background at similar levels to that found in the wild-type background indicating that, although the receptor is present and lacking the copper cofactor, it does not confer ethylene insensitivity. Presumably, protein levels of the other members of the ethylene receptor family are similarly unaffected. Thus, wild-type ethylene receptors lacking the copper cofactor have a loss-of-function phenotype (i.e. the *ran1-3* mutation produces the same constitutive ethylene response phenotype found in plant lines containing multiple loss-of-function mutations in the ethylene receptors). Wild-type receptors lacking the copper cofactor may adopt a signaling-inactive conformation similar to the confor-

mation of wild-type receptors that have ethylene bound (Fig. 7). In contrast, the amino acid changes that result from mutations like *etr1-1* (Cys-65-Tyr) result in a gain of function because they prevent not only copper binding but also lock the receptor into a signaling-active conformation such as it has in air (Fig. 7). The proposal that receptors in the *ran1-3* background are not equivalent to receptors containing ethylene-insensitive mutations is consistent with the finding that the ethylene-insensitive *etr1-3* mutant can suppress the *ran1-3* constitutive ethylene phenotype (Woeste and Kieber, 2000). The finding that ETR1 is still present in the *ran1-3* background also raises the possibility that not all mutations that eliminate ethylene binding will, as a consequence, confer ethylene insensitivity.

The loss-of-function mutants *etr1-5*, *etr1-6*, *etr1-7*, and *etr1-8* were isolated as intragenic suppressors of the ethylene insensitivity conferred by either *etr1-1* or *etr1-2*, and are predicted to result in premature termination of the encoded protein (Hua and Meyerowitz, 1998). However, we have found that a truncated version of *etr1-1* containing the first 349 amino acids is still capable of conferring ethylene insensitivity when transformed into *Arabidopsis* (Gamble et al., 2002). This raises the question as to why no ethylene insensitivity is observed with the loss-of-function mutants, in particular with *etr1-5* and *etr1-8*, which are predicted to code for receptors containing 562 amino acids. Our data indicate that the loss-of-function mutants may reduce expression at the transcriptional and posttranscriptional levels. Transcript, but no protein, was detected for each of the ETR1 loss-of-function mutants. Examination of *etr1-5* and *etr1-8* indicated a reduction to 43% and 23%, respectively, of wild-type mRNA levels. This reduction in expression could be because of mechanisms for mRNA surveillance such as nonsense-mediated decay whereby mRNAs containing premature stop codons are targeted for degradation (van Hoof and Green, 1996). However, the reduction in mRNA expression levels of *etr1-5* and *etr1-8* is probably not sufficient to reduce protein levels below detection limits for the antibodies. Thus, the results obtained with the loss-of-function mutations suggest that premature termination of the protein may lead to an absence of receptor rather than a truncated receptor, presumably because of instability of the truncated protein. The genetic screen for intragenic suppressors may have favored the isolation of destabilizing mutations.

To facilitate our analysis of ethylene pathway mutations, we isolated a T-DNA insertion mutation in the *ERS1* gene that, based on northern-blot analysis, substantially reduces expression of *ERS1*. As has been found in the analysis of loss-of-function genes in other ethylene receptors, the *ers1-2* mutant by itself had little effect upon ethylene responses in the mutant seedlings. However, a double mutant of *ers1-2*

and *etr1-7* exhibited a constitutive ethylene response. The phenotype observed with the *ers1-2;etr1-7* double mutant was comparable with that previously reported for an *etr1;etr2;ein4;ers2* quadruple loss-of-function mutant (Hua and Meyerowitz, 1998). These data suggest that ETR1 and ERS1 play more predominant roles in the regulation of ethylene signaling than the other three members of the ethylene receptor family. The relative importance of ETR1 and ERS1 could be because of the presence of His kinase activity (Gamble et al., 1998), the ability to interact with the downstream signaling component CTR1 (Clark et al., 1998), or possibly higher expression levels compared with those of the other ethylene receptors.

In summary, the results described here clarify the mode of action of ethylene pathway mutations previously identified in Arabidopsis. Mutations in the ethylene receptor ETR1 affected expression of the receptor at the posttranscriptional level. Similar mutations conferring ethylene insensitivity and intragenic suppressor mutations that result in premature stop codons have been identified in other members of the ethylene receptor family of Arabidopsis (Hua et al., 1995, 1998; Hua and Meyerowitz, 1998; Sakai et al., 1998). Thus, the mechanisms described here may be applicable to other ethylene receptors besides ETR1.

## MATERIALS AND METHODS

### Plant Material and Growth Conditions

Arabidopsis mutants in the ecotype Columbia were used for all experiments except those involving the *ers1-2* mutant, which was in the ecotype Wassilewskija. The ERS1 T-DNA insertion allele (*ers1-2*) was isolated from the 60,480 kanamycin-resistant T-DNA-tagged Arabidopsis lines of the University of Wisconsin Knockout Arabidopsis facility (<http://www.biotech.wisc.edu/Arabidopsis>). The mutant was identified with a PCR primer for the T-DNA left border (CATTATAATAACGCTGCGGACATCTAC) and an ERS1-specific primer (CAGAGAGTTCTGCTACTCCTGGAAATGGT). Plants containing the wild-type ERS1 gene were identified by use of PCR with the above ERS1 primer and a second ERS1-specific primer (CACAAACCGCGCAAGAGACTTAGCAATAGT). The *ers1-2;etr1-7* double mutant was identified by crossing plants homozygous for the single mutations and subsequent PCR-based genotyping of F<sub>2</sub> progeny according to Hua and Meyerowitz (1998). Upon request, the *ers1-2* mutant and all novel materials described in this publication will be made available in a timely manner for noncommercial research purposes.

Unless indicated otherwise, seedlings were grown on 0.8% (w/v) agar plates of one-half-strength Murashige and Skoog basal medium (pH 5.65) with Gamborg's vitamins (Murashige and Skoog media, Sigma, St. Louis). Seeds were stratified for 2 d at 4°C before growth at 22°C. Seeds were exposed to light for 12 h, then incubated in the dark. Seedlings were typically examined after 4 d, with time 0 corresponding to when the plates were removed from 4°C and brought to 22°C. For ethylene treatment, seedlings were grown in sealed chambers in the presence of 50 L L<sup>-1</sup> ethylene. Measurements of hypocotyl length were performed as described by Gamble et al. (2002). For analysis of the *ran1-3* mutant, seedlings from a segregating population were grown for 4 weeks under an 8-h light cycle to allow for maximal rosette development before harvest. Homozygous *ran1-3* seedlings were identified based on their readily distinguishable constitutive ethylene response phenotype (Woeste and Kieber, 2000).

### Antibodies

The anti-ETR1(401–738) antibody was prepared against a glutathione S-transferase (GST) fusion protein with amino acids 401 to 738 of ETR1

(Schaller et al., 1995) and was used for detection of ETR1 in all cases except where indicated in Figure 3. The serum was depleted of antibodies that cross-react with GST by passing through a column of Affigel-10 (Bio-Rad Laboratories, Hercules, CA) cross-linked to GST. The antibody was affinity purified by binding to an Affigel column cross-linked to GST-ETR1(401–738) (Schaller et al., 1995), then eluted with 0.1 M Gly (pH 2.5). The anti-ETR1(165–400) antibody used for Figure 3 was prepared against a GST fusion protein with amino acids 165 to 400 of ETR1 (Schaller et al., 1995) and was affinity purified as described (Gamble et al., 2002). The anti-(H<sup>-</sup>ATPase) antibody (DeWitt et al., 1996) used as an internal loading control was provided by Dr. Michael Sussman (University of Wisconsin, Madison).

### Protein Isolation and Immunoblot Analysis

For isolation of Arabidopsis membranes, plant material was homogenized at 4°C in extraction buffer (50 mM Tris [pH 8.5], 150 mM NaCl, 10 mM EDTA, and 20% [v/v] glycerol) containing 1 mM phenylmethylsulfonyl fluoride, 1 g mL<sup>-1</sup> pepstatin, 10 g mL<sup>-1</sup> aprotinin, and 10 g mL<sup>-1</sup> leupeptin as protease inhibitors. The homogenate was strained through Miracloth (Calbiochem-Novobiochem, San Diego) and centrifuged at 8,000g for 15 min. The supernatant was centrifuged at 100,000g for 30 min, and the membrane pellet was resuspended in 10 mM Tris (pH 7.5), 150 mM NaCl, 1 mM EDTA, and 10% (v/v) glycerol with protease inhibitors. Protein concentration was determined by a modification of the Lowry assay (Lowry et al., 1951) in which samples were treated with 0.4% (w/v) sodium deoxycholate (Schaller and DeWitt, 1995). Bovine serum albumin was used as a standard for protein assays.

For immunoblot analysis, membranes were mixed with SDS-PAGE loading buffer and incubated at 37°C for 1 h. Proteins were fractionated by SDS-PAGE using 8% (w/v) polyacrylamide gels (Laemmli, 1970). After electrophoresis, proteins were either stained with Coomassie Blue or electrotransferred to Immobilon nylon membrane (Millipore, Bedford, MA). Immunoblotting was performed by using anti-ETR1(165–400), anti-ETR1(401–738), or anti-(H<sup>-</sup>ATPase) polyclonal antibodies. Immunodecorated proteins were visualized by enhanced chemiluminescence detection according to the manufacturer (Pierce Chemical, Rockford, IL). Densitometric analysis was performed by using the NIH Image program (<http://rsb.info.nih.gov/nih-image>) after first scanning the exposed film and then capturing the images with Photoshop (Adobe Systems, San Jose, CA). The relative expression level for ETR1 was quantified by comparison to a dilution series of ETR1.

### Northern-Blot Analysis

Total RNA was extracted from Arabidopsis tissue according to the method of Carpenter and Simon (1998). For Figures 1 and 3, RNA was isolated from etiolated seedlings; and for Figure 5, RNA was isolated from 15-d-old leaf tissue of plants grown in liquid culture as described by Chang et al. (1992). mRNA was isolated from total RNA using the PolyAtract mRNA isolation system (Promega, Madison, WI). For northern-blot analysis, RNA was separated on 1% (w/v) agarose gels using the NorthernMax-Gly kit (Ambion, Austin, TX) according to the manufacturer's instructions. RNA was transferred to nylon membrane by the capillary method and fixed by UV cross-linking. Hybridizations were performed using buffers supplied with the NorthernMax-Gly kit. Single-stranded DNA antisense probes were made using primers designed to anneal at the 3' end of the selected genes. Radiolabeled probes were made and the blot stripped between hybridizations by using the Strip-EZ PCR kit (Ambion) according to the manufacturer's instructions. Radioactivity was imaged and quantitated by phosphor imaging with a Molecular Imager FX (Bio-Rad Laboratories), using accompanying Quantity One software.

### ACKNOWLEDGMENTS

We thank Michael Sussman for providing the anti-(H<sup>-</sup>ATPase) antibody, Jian Hua and Elliot Meyerowitz for the ethylene receptor loss-of-function seed lines, Yi-Feng Chen for assistance with affinity purification of antibodies, and Anita Klein and Estelle Hrabak for critical reading of the manuscript.

Received July 23, 2002; returned for revision August 18, 2002; accepted August 30, 2002.

## LITERATURE CITED

- Abeles FB, Morgan PW, Saltveit ME Jr (1992) *Ethylene in Plant Biology*, Ed 2. Academic Press, San Diego
- Alonso JM, Hirayama T, Roman G, Nourizadeh S, Ecker JR (1999) EIN2, a bifunctional transducer of ethylene and stress responses in *Arabidopsis*. *Science* 284: 2148–2152
- Bérard J, Luo H, Chen H, Mukuna M, Bradley WE, Wu J (1997) Abnormal regulation of retinoic acid receptor beta2 expression and compromised allograft rejection in transgenic mice expressing antisense sequences to retinoic acid receptor beta1 and beta3. *J Immunol* 159: 2586–2598
- Bleecker AB (1999) Ethylene perception and signaling: an evolutionary perspective. *Trends Plant Sci* 4: 269–274
- Carpenter CD, Simon AE (1998) Preparation of RNA. In JM Martinez-Zapater, J Salinas, eds, *Methods in Molecular Biology*, Vol 82: *Arabidopsis Protocols*. Humana Press, Totowa, NJ, pp 85–89
- Chang C, Kwok SF, Bleecker AB, Meyerowitz EM (1993) *Arabidopsis* ethylene response gene ETR1: similarity of product to two-component regulators. *Science* 262: 539–544
- Chang C, Schaller GE, Patterson SE, Kwok SF, Meyerowitz EM, Bleecker AB (1992) The TMK1 gene from *Arabidopsis* codes for a protein with structural and biochemical characteristics of a receptor protein kinase. *Plant Cell* 4: 1263–1271
- Chang C, Shockey JA (1999) The ethylene-response pathway: signal perception to gene regulation. *Curr Opin Plant Biol* 2: 352–358
- Chang C, Stadler R (2001) Ethylene hormone receptor action in *Arabidopsis*. *BioEssays* 23: 619–627
- Chao Q, Rothenberg M, Solano R, Roman G, Terzaghi W, Ecker JR (1997) Activation of the ethylene gas response pathway in *Arabidopsis* by the nuclear protein ETHYLENE-INSENSITIVE3 and related proteins. *Cell* 89: 1133–1144
- Clark KL, Larsen PB, Wang X, Chang C (1998) Association of the *Arabidopsis* CTR1 Raf-like kinase with the ETR1 and ERS1 ethylene receptors. *Proc Natl Acad Sci USA* 95: 5401–5406
- DeWitt ND, Hong B, Sussman MR, Harper JF (1996) Targeting of two *Arabidopsis* H<sup>+</sup>-ATPase isoforms to the plasma membrane. *Plant Physiol* 112: 833–844
- Gamble RL, Coonfield ML, Schaller GE (1998) Histidine kinase activity of the ETR1 ethylene receptor from *Arabidopsis*. *Proc Natl Acad Sci USA* 95: 7825–7829
- Gamble RL, Qu X, Schaller GE (2002) Mutational analysis of the ethylene receptor ETR1. Role of the histidine kinase domain in dominant ethylene insensitivity. *Plant Physiol* 128: 1428–1438
- Hall AE, Chen QG, Findell JL, Schaller GE, Bleecker AB (1999) The relationship between ethylene binding and dominant insensitivity conferred by mutant forms of the ETR1 ethylene receptor. *Plant Physiol* 121: 291–299
- Hall AE, Findell JL, Schaller GE, Sisler EC, Bleecker AB (2000) Ethylene perception by the ERS1 protein in *Arabidopsis*. *Plant Physiol* 123: 1449–1458
- Hirayama T, Kieber JJ, Hirayama N, Kogan M, Guzman P, Nourizadeh S, Alonso JM, Dailey WP, Dancis A, Ecker JR (1999) RESPONSIVE-TO-ANTAGONIST1, a Menkes/Wilson disease-related copper transporter, is required for ethylene signaling in *Arabidopsis*. *Cell* 97: 383–393
- Hua J, Chang C, Sun Q, Meyerowitz EM (1995) Ethylene insensitivity conferred by *Arabidopsis* ERS gene. *Science* 269: 1712–1714
- Hua J, Meyerowitz EM (1998) Ethylene responses are negatively regulated by a receptor gene family in *Arabidopsis thaliana*. *Cell* 94: 261–271
- Hua J, Sakai H, Nourizadeh S, Chen QG, Bleecker AB, Ecker JR, Meyerowitz EM (1998) EIN4 and ERS2 are members of the putative ethylene receptor family in *Arabidopsis*. *Plant Cell* 10: 1321–1332
- Kieber JJ, Rothenberg M, Roman G, Feldman KA, Ecker JR (1993) CTR1, a negative regulator of the ethylene response pathway in *Arabidopsis*, encodes a member of the Raf family of protein kinases. *Cell* 72: 427–441
- Laemmli UK (1970) Cleavage of structural proteins during the assembly of the head of bacteriophage T4. *Nature* 227: 680–685
- Lowry OH, Rosebrough NJ, Farr AL, Randall RJ (1951) Protein measurement with the Folin phenol reagent. *J Biol Chem* 193: 265–275
- Mattoo AK, Suttle JC, editors (1991) *The Plant Hormone Ethylene*. CRC Press, Inc., Boca Raton, FL
- Minkoff R, Bales ES, Kerr CA, Struss WE (1999) Antisense oligonucleotide blockade of connexin expression during embryonic bone formation: evidence of functional compensation within a multigene family. *Dev Genet* 24: 43–56
- Mulligan GJ, Wong J, Jacks T (1998) p130 is dispensable in peripheral T lymphocytes: evidence for functional compensation by p107 and pRB. *Mol Cell Biol* 18: 206–220
- Parkinson JS (1993) Signal transduction schemes of bacteria. *Cell* 73: 857–871
- Rodriguez FI, Esch JJ, Hall AE, Binder BM, Schaller GE, Bleecker AB (1999) A copper cofactor for the ethylene receptor ETR1 from *Arabidopsis*. *Science* 283: 996–998
- Sakai H, Hua J, Chen QG, Chang C, Medrano LJ, Bleecker AB, Meyerowitz EM (1998) ETR2 is an ETR1-like gene involved in ethylene signaling in *Arabidopsis*. *Proc Natl Acad Sci USA* 95: 5812–5817
- Schaller GE (2000) Histidine kinases and the role of two-component systems in plants. *Adv Bot Res* 32: 109–148
- Schaller GE, Bleecker AB (1995) Ethylene-binding sites generated in yeast expressing the *Arabidopsis* ETR1 gene. *Science* 270: 1809–1811
- Schaller GE, DeWitt ND (1995) Analysis of the H<sup>+</sup>-ATPase and other proteins of the *Arabidopsis* plasma membrane. *Methods Cell Biol* 50: 129–148
- Schaller GE, Ladd AN, Lanahan MB, Spanbauer JM, Bleecker AB (1995) The ethylene response mediator ETR1 from *Arabidopsis* forms a disulfide-linked dimer. *J Biol Chem* 270: 12526–12530
- Stepanova AN, Ecker JR (2000) Ethylene signaling: from mutants to molecules. *Curr Opin Plant Biol* 3: 353–360
- Tieman DM, Taylor MG, Ciardi JA, Klee HJ (2000) The tomato ethylene receptors NR and LeETR4 are negative regulators of ethylene response and exhibit functional compensation within a multigene family. *Proc Natl Acad Sci USA* 97: 5663–5668
- van Hoof A, Green PJ (1996) Premature nonsense codons decrease the stability of phytohemagglutinin mRNA in a position-dependent manner. *Plant J* 10: 415–424
- Wiley HS (1992) Receptors: topology, dynamics, and regulation. In EE Bittar, ed, *Fundamentals of Medical Cell Biology*, Vol 5A. JAI Press Inc., Greenwich, CT, pp 113–142
- Woeste KE, Kieber JJ (2000) A strong loss-of-function mutation in RAN1 results in constitutive activation of the ethylene response pathway as well as a rosette-lethal phenotype. *Plant Cell* 12: 443–455