



# VCU

Virginia Commonwealth University  
VCU Scholars Compass

---

Theses and Dissertations

Graduate School

---

2019

## Design and Testing of an Agonist-Antagonist Position-Impedance Controlled Myoelectric Prosthesis

Christopher Aymonin  
*Virginia Commonwealth University*

Follow this and additional works at: <https://scholarscompass.vcu.edu/etd>

 Part of the [Bioelectrical and Neuroengineering Commons](#), [Other Biomedical Engineering and Biengineering Commons](#), and the [Systems and Integrative Engineering Commons](#)

© The Author

---

Downloaded from

<https://scholarscompass.vcu.edu/etd/5901>

This Thesis is brought to you for free and open access by the Graduate School at VCU Scholars Compass. It has been accepted for inclusion in Theses and Dissertations by an authorized administrator of VCU Scholars Compass. For more information, please contact [libcompass@vcu.edu](mailto:libcompass@vcu.edu).

DESIGN AND TESTING OF AN AGONIST-ANTAGONIST POSITION-  
IMPEDANCE CONTROLLED MYOELECTRIC PROSTHESIS

A thesis submitted to fulfill the requirements for the degree of Master of Science  
in Biomedical Engineering at Virginia Commonwealth University

by

CHRISTOPHER AYMONIN

B.S. in Biomedical Engineering, University of Miami, May 2014

Director: DR. DIANNE PAWLUK

ASSOCIATE PROFESSOR, DEPARTMENT OF BIOMEDICAL ENGINEERING

Director: DR. PETER PIDCOE

PROFESSOR, DEPARTMENT OF PHYSICAL THERAPY

Virginia Commonwealth University

Richmond, Virginia

2018-2019

# Acknowledgements

I would like to thank Dr. Pawluk and Dr. Pidcoe for giving me the opportunity to work on a project that I have always dreamed of. Each day was a challenge, but thanks to your guidance and support, I was able to adapt and learn to solve each new problem. I have grown to become a better engineer and a better professional. I appreciate your help, and I will always be grateful for this opportunity.

Thank you also to my committee for all of the ways you have helped me to learn during my time at VCU. Dr. Wayne and Dr. Shall, your classes were some of my favorite as I pursued this degree, and I am honored that you agreed to participate in my thesis defense.

To the countless friends I have made at the University of Miami and Virginia Commonwealth University over the past ten years, I treasure the memories we have shared. Thank you for making each day a new adventure!

To my family, I am so grateful for your constant love and support. Thank you especially to Grandpa Frank, who inspired me to become an engineer and made it possible for me to earn not only my B.S. but also this M.S.

To my wife, Pam, I can't wait to see the smile on your face once I'm finally able to tell you that it's done! Although it has taken longer than either of us expected, I am so grateful for your support and the joy you bring to my life each day. I am excited to be able to truly begin our lives together. I can't wait to see what comes next!

# Table of Contents

<b>Abstract.....</b>	<b>vii</b>
<b>1 Introduction .....</b>	<b>1</b>
1.1 Background.....	4
1.1.1 Limb Loss.....	4
1.1.2 Prosthetic Acceptance.....	4
1.1.3 Activities of Daily Living .....	5
1.1.4 Control of Myoelectric Prosthesis .....	6
1.1.5 Human System Considerations .....	9
1.2 Project Aims and Goals .....	10
1.3 Thesis Outline.....	12
<b>2 Device Design, Fabrication, and Control.....</b>	<b>13</b>
2.1 Prosthetic Simulator Design and Fabrication.....	14
2.2 Prosthetic Simulator Control .....	16
2.2.1 Myoelectric Commanded Position .....	17
2.2.2 Flexor Servo.....	20
2.2.3 Extensor Servo.....	21
2.3 Device Characterization.....	24
<b>3 Assessment of Agonist-Antagonist Position-Impedance Controller.....</b>	<b>26</b>
3.1 Bimanual Task.....	26

3.1.1	ADL Station .....	28
3.1.2	Tube Preparation.....	28
3.2	A Priori Determination of Stiffness .....	29
3.3	Experimental Methods .....	30
3.3.1	Experimental Design .....	31
3.3.2	Experimental Procedure .....	31
3.4	Statistical Methods.....	39
<b>4</b>	<b>Results .....</b>	<b>41</b>
4.1	Volume Extrusion Error.....	41
4.1.1	Analysis of Differences .....	41
4.1.2	Analysis of Equivalence.....	49
4.2	Response Time.....	51
4.2.1	Analysis of Differences .....	51
4.2.2	Analysis of Equivalence.....	56
<b>5</b>	<b>Discussion .....</b>	<b>58</b>
5.1	Unexpected Findings .....	62
5.2	Limits .....	62
5.3	Practical Implications .....	65
5.4	Perspective and Future Considerations.....	66
<b>6</b>	<b>Conclusion.....</b>	<b>70</b>

<b>7</b>	<b>References</b>	<b>72</b>
	<b>Appendix A: System Code</b>	<b>76</b>
	<b>Appendix B: Device Design Documents</b>	<b>99</b>
	<b>Appendix C: Testing Forms &amp; Protocols</b>	<b>101</b>
	<b>Appendix D: Results Data</b>	<b>116</b>

## List of Figures

Figure 1:	Control Algorithm Comparisons	7
Figure 2:	System Design Overview	13
Figure 3:	Prosthetic Simulator	15
Figure 4:	Agonist-antagonist Position-Impedance Control	16
Figure 5:	User Input Overview	17
Figure 6:	User Training Feedback Display	20
Figure 7:	Flexor Position Control	20
Figure 8:	Device Impedance Controller	22
Figure 9:	Force Controller Trajectories	24
Figure 10:	Comparison of Achieved Stiffness vs. Commanded Stiffness	25
Figure 11:	ADL Stations Human Hand vs. Device	27
Figure 12:	Subject Position for Prosthetic Control	33
Figure 13:	Standard Lead Locations for Flexor and Extensor EMG	34
Figure 14:	LabVIEW VI Interface	36
Figure 15:	Device Modes and Indicators	38

Figure 16: Volume Extrusion Error: Estimated Marginal Means: Repetition.....	43
Figure 17: Volume Extrusion Error: Estimated Marginal Means: Tube Type.....	44
Figure 18: Volume Extrusion Error: Estimated Means: Tube Type * Repetition.....	45
Figure 19: Volume Extrusion Error vs. Tube Stiffness.....	47
Figure 20: Volume Extrusion Error: Estimated Marginal Means: Order.....	49
Figure 21: Distribution of Difference: Volume Extrusion Error.....	50
Figure 22: Response Time: Estimated Marginal Means: Repetition.....	53
Figure 23: Response Time: Estimated Marginal Means: Tube Type.....	54
Figure 24: Response Time: Estimated Marginal Means: Tube Type * Repetition.....	55
Figure 25: Distribution Ratio Response Time.....	56

## List of Tables

Table 1: GEE Model Volume Extrusion Error.....	42
Table 2: Test of Model Effects: Volume Extrusion Error.....	42
Table 3: Volume Extrusion Error: Final Model.....	43
Table 4: Test of Model Effects: Volume Extrusion Error: Order.....	48
Table 5: TOST Equivalency: Volume Extrusion Error.....	50
Table 6: GEE Model Response Time.....	51
Table 7: Test of Model Effects: Response Time.....	51
Table 8: Response Time: Final Model.....	52
Table 9: TOST Equivalency: Response Time.....	57

## **Abstract**

### **DESIGN AND TESTING OF AN AGONIST-ANTAGONIST POSITION-IMPEDANCE CONTROLLED MYOELECTRIC PROSTHESIS**

By Christopher Aymonin, B.S. Biomedical Engineering

A thesis submitted to fulfill the requirements for the degree of Master of Science in Biomedical Engineering at Virginia Commonwealth University

Virginia Commonwealth University, 2019

Director: Dianne Pawluk Ph.D

Associate Professor, Department of Biomedical Engineering

Director: Peter Pidcoe Ph.D, DPT

Professor, Department of Physical Therapy

Intuitive prosthetic control is limited by the inability to easily convey intention and perceive physical requirements of the task. Rather than providing haptic feedback and allowing users to consciously control every component of manipulation, relegating some aspects of control to the device may simplify operation. This study focuses on the development and testing of a control scheme able to identify object stiffness and regulate impedance. The system includes an algorithm to detect the apparent stiffness of an object, a proportional nonlinear EMG control algorithm for interpreting a user's desired grasp aperture, and an antagonistically acting impedance controller. Performance of a testbed prosthetic simulation used to controllably extrude pastes of different properties from a compliant tube was compared to that of the non-dominant human hand. The paste



volume extrusion error and response time to perform the task were recorded for comparison. Statistical analysis using (GEE) and (TOST) suggests the prosthetic controller and human hand performed similarly along these metrics. Performance differences in the trials were more strongly correlated to tube type and repetition block. The results suggest that the developed controller allows users to perform a controlled squeezing task at a level comparable to the human hand with minimal training. It also suggests that a priori stiffness estimation acquired through quick palpations may be sufficient for effective control during simple manipulation. The lack of a learning curve suggests that the development of systems that automatically control aspects of mechanical interaction may offer users more advanced control capabilities with low cognitive load.

# 1 Introduction

Modern day myoelectric upper limb prosthetics provide a great opportunity to restore function to those who are missing limbs. They offer users advanced functionality compared to body powered prosthetics by utilizing the body's neural signals for control. A number of impressively dexterous robotic hands have been developed, however the ability to control these sophisticated designs is limited by the number of neural inputs available and lack of sufficient sensory feedback. These limitations make usage less intuitive, increasing cognitive load and often contributing to user rejection of the prosthetic (Spires, Kelly, & Davis, 2014). To the user, these complex prostheses provide less usable functionality than simpler prostheses. This is compounded by the typical lack of focus in these designs on the ability of the user to perform activities of daily living (ADLs).

In addition, much of the research involving prosthetic hand control has focused on single hand grasping and manipulation with the prosthetic hand. However, typically, individuals who have hand prosthesis have one healthy hand and one hand replaced by a prosthetic (Tennent, Wenke, Rivera, & Krueger, 2014). One handed tasks can more easily be performed by the remaining healthy hand. Two handed tasks, though, require the use of the prosthetic hand. In many bimanual tasks, one hand (the healthy hand) requires dexterity while the other is used to maintain stability or perform less dexterous tasks. For example, cutting foods of variable compliance (e.g. tomatoes, bread, meat, etc.) on a cutting board requires one hand to cut and the other to stabilize the food without excessively deforming it. Another example, is extruding a paste or gel from a tube onto

another item being held (e.g. toothpaste on a toothbrush) or a healthy finger for use (e.g., shampoo or cream).

The focus of this thesis is on providing hand prosthetic users with the ability to perform two handed activities of daily living intuitively and with low cognitive load. The particular focus is on tasks that involve compliant objects that need to be stabilized or have simple forces applied, such as by squeezing. The approach will be to consider modifications to current prosthetic control algorithms to achieve this goal.

For prosthetic control, components of the hand are typically controlled using surface electromyography (EMG) from the residual distal muscles. Control schemes in commercial devices regulate the force or speed applied by the prosthetic in a manner proportional to the magnitude of the EMG signals or utilize a digital control scheme which switches the device on or off in response to user command signals. However, a recent study found that a non-linear control algorithm (mimicking muscle properties) was more effective than either of the two commonly used algorithms for force or speed (Arenas, 2015). Although methods controlling force or position are commonly used in myoelectric prosthetics, it has been suggested that impedance control, which allows for specification and control of dynamic behavior of both position and force during interaction, offers superior control in variable environments (Hogan, 1985).

Modulation of the mechanical impedance of muscles in the human system is used as a form of adaptive control to accommodate to changes in environmental conditions. Simultaneously contracting opposing muscles allows for the body to modify the interaction force or impedance with an object while also controlling the endpoint position. A prior study on control of a prosthetic elbow joint allowed able bodied users to modulate device

impedance and endpoint position through co-contraction of the agonist and antagonist muscles. However, they found that the mental load involved dissuaded participants from actively changing the impedance unless the system's tuning was very poor for the task (Sensing & Weir, 2007).

These results suggest that mimicking muscle properties, such as to achieve nonlinear myoelectric control and impedance control may be of advantage to prosthetic users but issues of mental load need to be considered. In particular, is there an easier way to change the impedance appropriately based on the current environmental/contact conditions? To investigate this issue, we consider what the human system does when grasping and manipulating objects.

During prehension, the human system uses prior knowledge to create assumptions regarding object properties as it prepares for interaction. After contact, it automatically adjusts the initial estimate based on afferent feedback that either confirms or alters the prediction. These subconscious adaptations allow the human system to successfully adapt to almost any object. Considering prosthetic interfacing difficulties regarding lack of input control signals and insufficient feedback, relegating both object stiffness identification and control of impedance to the device may offer better control without increasing mental load.

Based on the above considerations, this thesis focuses on the design and testing of a myoelectric prosthetic interface able to modulate impedance to allow interactions with a variety of compliant objects during bimanual manipulation tasks based on an initial palpation of the material to gauge apparent stiffness.

## 1.1 Background

### 1.1.1 Limb Loss

The human hand is one of the most complex systems within the human body. It can accomplish a wide variety of configurations and grasps while interacting with objects of all shapes, sizes, and physical properties (Duruoz, 2014). Upper limb amputation in the United States is rare, consisting of only 3% of the U.S. population, most often caused by trauma (Spires et al., 2014). However, because the use of the hands is so integral to the performance of activities of daily living, the loss of a hand can have a devastating impact on a person's life. The toll goes beyond just the physical, also impacting the amputee emotionally and psychologically. Without an effective rehabilitation process, the amputee will have decreased independence and functionality (Spires et al., 2014).

The most common upper limb amputation is a trans-radial (below elbow) amputation of a single hand. During surgery, additional effort is made to preserve the elbow joint to retain greater functional use of the arm. The number of bilateral arm amputees is an even smaller subset of the population in many Western countries. The UK averages only two cases per year (Engstrom, 1999).

### 1.1.2 Prosthetic Acceptance

For the estimated 158,000 people who undergo a limb amputation each year, prosthetic devices can help to provide a sense of normalcy and independence (Raichle et al., 2008). A prosthesis can be thought of as a tool that must meet the user's needs. No prosthesis is able to fully replace all functions satisfactorily. The device may be cosmetic, functional, or a combination of both. Decorative prosthesis attempt to make it

appear as if the limb is not missing, however offer little functionality. Functional prosthesis focus on restoring capabilities to the amputees. They may be body powered, pneumatic, or myoelectric (Engstrom, 1999).

Although it may seem like a prosthetic is a natural solution to an amputation. The rejection rate by the users of the prosthetics is estimated between 39-53% (Biddiss, Beaton, & Chau, 2007). Amputees who do use prosthetics often only wear them part of the day (Raichle et al., 2008). Other amputees may not see a need for a prosthetic, as they find new ways to accomplish most tasks using only their remaining limb (Washam, 1973). It should be remembered that the functionality of a prosthesis is not a hand replacement, but rather a tool to help the user achieve a desired result. One way to reduce the likelihood of rejection is to design the prosthetic with its situational usage in mind.

### 1.1.3 Activities of Daily Living

After loss of the upper limb, much of rehabilitation is targeted towards restoring independence by improving performance at activities of daily living (ADL). ADLs help to determine the level of independence and ability for self-care. These activities typically involve self-grooming, dressing, or food preparation. Focusing on improving ADL performance improves the likelihood that users will actually use the prosthetic in their day to day life, thus reducing the chances of prosthetic rejection (Sacchetti et al., 2016).

Bimanual ADLs are tasks that require using two hands. Some tasks require more active manipulation using both hands, but many operate with one dexterous hand while the other stabilizes the object or performs simple functions on it. However, many two

handed ADLs can be performed with a healthy dexterous hand and a prosthetic performing relatively simple operations. This is the focus of our research.

Manipulation of compliant objects is a common task that people perform on a daily basis. For some tasks, compliance makes interaction easier as it provides more tolerance for uncertainty. A prior concept for a prosthetic used a compliant end effector that helped to avoid undesired contact forces during interaction. The hand was compliant when unactuated and rigid when actuated, however it had no ability to control the endpoint position and as a result was unable to perform precision grasping without use of the unaffected hand (Dollar & Howe, 2007). A purely compliant grasp may be useful in some applications, however other tasks (such as stabilizing compliant food items when cutting or squeezing tubes containing viscous fluids) require the ability to control the deformation. This makes the task much more complex and creates a need to control both the impedance and position during interaction.

#### 1.1.4 Control of Myoelectric Prosthesis

Myoelectric prosthesis use electromyography (EMG) to read the motor control signals arriving at residual distal muscles in order to offer the user the ability to control the movement of the prosthetic. Surface electrodes measure the sum signal of activity that exists in the underlying muscle and provide a non-invasive method of obtaining user movement intent. However, EMG can only provide a limited number of input channels to a prosthetic system due to the difficulty of obtaining distinct signals because of muscle crosstalk (Plettenburg, 2006).

Still, myoelectric prosthesis allow the user more advanced functionality than body powered prosthesis by reading user intent from the neural signals within the muscle. Through this method, the prosthesis can respond to neural signals in a way similar to the human hand. There are a variety of methods of different complexity that are used to translate user intention to movement of the prosthesis. Different algorithms are used to correlate EMG activation level to position or force or to recognize temporal patterns of activation to alter hand configurations (Figure 1).

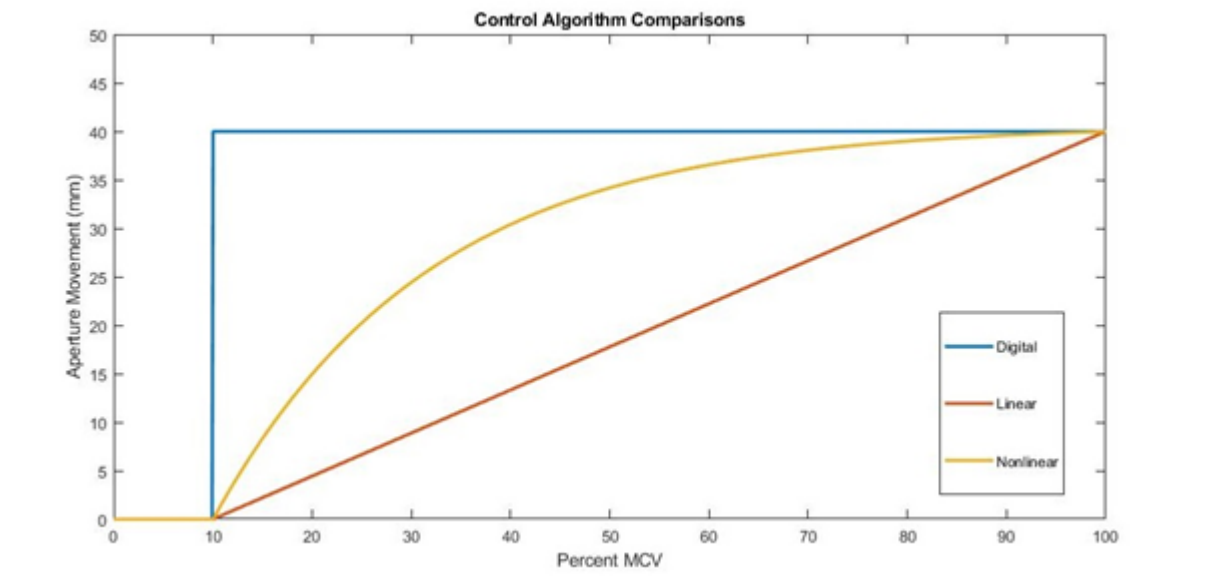

**Figure 1: Control Algorithm Comparisons**

Three algorithms used to correlate EMG activation level to position.

Digital (“bang-bang”) control is the most common method used to control EMG prosthetic devices. EMG activity above a certain threshold will completely close the grasp. Activity below the threshold will open the grasp. Proportional Linear control offers a more complex ability to control manipulation. EMG activity is mapped to a position or force level. This method requires more training in order to use effectively, but offers



superior control compared with Digital control (Smurr, Gulick, & Yancosek, 2008). A recent study suggests that Proportional Non-Linear control, a mapping based on the EMG-force relation of muscles, may offer better ease of control than Proportional Linear (Arenas, 2015). Although subjects were eventually able to achieve the same peak performance through training regardless of algorithm, the study showed that users were able to adapt to the Proportional Nonlinear control method more quickly, suggesting that the algorithm is more closely based on the natural activation patterns of the muscles.

When using only force or position to control a prosthetic device, the environment plays a part in determining the interaction that occurs. The environment introduces an error in the desired actions of the prosthetic that the controller works to reduce. Robotic systems are adept at performing precision tasks with known forces in controlled environments. However many situations exist where the environment is unknown. The systems may find themselves unable to perform as expected due to unanticipated forces encountered in the environment. During an ADL such as extrusion of a compliant paste, successful operation depends on the ability of the prosthetic system to control the changing forces that occur during deformation of the tube. This requires the ability to manage the relationship between the movement of the fingertips and the force that occurs or, in other words, the impedance. Impedance control offers a more robust control method that allows manipulator impedance to be specified at the interaction point independent of the environment. Controlling impedance allows for control over the exchange of energy between the device and the object of interest (Hogan, 1984b).

### 1.1.5 Human System Considerations

The human system also modulates the impedance of a healthy hand to deal with uncertainty. Setting the impedance of the hand determines the reaction forces that arise during perturbations. The impedance of the human system involves contributions from the passive properties of muscle tissue, the orientation of joints, and the co-contraction level of antagonistic muscles. Modifying the orientation of a limb changes the existing force transfer functions by changing the kinematics of the grip. (Höppner, McIntyre, & Van Der Smagt, 2013). Agonist-antagonist co-contraction of opposing muscles allows for a decoupling of limb endpoint force and position, allowing each to be controlled independently. This allows the body to regulate impedance to optimize grasp stability during manipulation (Hogan, 1984a).

#### ***Prehension***

Prior to grasping a new object, the human system creates a prediction of object properties based on previous experience with similar objects. The central nervous system prescales the grasp to reflect mental models of predicted object and task properties. Depending on the task and predicted properties, a different stiffness level may be appropriate. Stabilization tasks require higher stiffness, while a lower stiffness may be used to absorb an imminent impact. Post contact, afferent feedback from the body's sensory receptors either confirms or adjusts the grasp and updates the mental model for interaction with the object (Wing, Haggard, & Flanagan, 1996). This allows the body to learn to adapt to nearly any grasping situation.

## ***Interaction With Prosthetics***

After amputation, prosthetic users are unable to scale prosthetic control parameters as fluidly as the human system due to the severing of afferent and efferent signals. The ability of the body to subconsciously predict and scale anticipatory parameters and adjust the interaction according to feedback allows humans to focus on the task rather than details of the interaction.

Human response time is relatively slow; latencies for even the fastest reflexes are at least 20-30ms, with even slower voluntary responses usually ranging between 100-200ms (Hatzfeld & Kern, 2014). Slow response times are overcome in the human system by anticipatory adjustment of impedance prior to manipulation (Howe, 1994).

Attempts to allow users to voluntarily control prosthetic impedance showed that subjects were either unwilling or physically unable to fine-tune the impedance of a prosthetic through co-contraction. Subjects avoided voluntarily adjusting device impedance unless the default setting provided very poor control. It was suggested that future studies should attempt to lower the mental load by providing users with several preset stiffness values rather than allowing complete voluntary modulation (Sensinger & Weir, 2007).

## **1.2 Project Aims and Goals**

While it is difficult to overcome the existing limitations created due to the small number of control and feedback signals, with certain design decisions it may be possible to create a prosthesis that meets the needs of its users and improves upon existing methods. Remembering that the prosthesis is a tool, not a replacement, it is important to

ensure that the prosthesis is designed with ADLs in mind. After a task analysis of many common ADLs, it became clear that two handed manipulation tasks requiring cooperative actions of the hand were an area of need, particularly those tasks requiring something more than a grab and hold.

Two handed tasks involving interaction with compliant objects require complex sensory and manipulation abilities to avoid changing the object in an undesirable way. Compliant objects are more difficult to handle since their surface is deformable and force may vary depending on object properties. The human body deals with uncertainty by modulating impedance. This allows the body to compensate for errors in predicted force and position. In a similar way, impedance control may be used to help robotic systems handle uncertain and unstable environments. Voluntarily modulating the stiffness of a joint requires a great deal of mental effort and training. The human system is able to adapt the stiffness as necessary with compliant muscle properties and modulation of stiffness through co-contraction. A system that could perform a similar stiffness modulation without the user actively involved could improve manipulation while remaining simple to use.

The aim of this study was to develop a prosthetic interface able to modulate impedance for interaction with a variety of compliant objects based on an initial palpation of materials to gauge apparent stiffness. To accomplish this, (1) the device should be able to identify properties of the object of interest, (2) allow the user to control the device intuitively, and (3) be able to cope with uncertainties in surface forces and position without user involvement.

This study focuses on the development and testing of an auto-selecting agonist-antagonist position impedance controller. A prosthetic simulator was created in order to test the control system. The system includes an algorithm to detect the apparent stiffness of an object, a proportional nonlinear EMG control algorithm for interpreting user positional desire, and an impedance controller acting in opposition to the position controller for modulation of the stiffness and force during interaction with a compliant object. The system was tested against the human hand in a bimanual paste extrusion task involving a variety of complaint tubes. The paste volume extrusion error and the response time to perform the task were recorded for comparison. The performance of the developed system at a bimanual extrusion task should be equivalent when compared with performance of the human hand.

### 1.3 Thesis Outline

The following chapters cover the design, fabrication, and control of the prosthetic device, a description of the methods used to assess the device, the experimental results, discussion, and conclusion. Chapter 2 describes the design of the physical device, interfacing algorithm, and control schemes. Chapter 3 then covers the bimanual task, experimental protocol, and statistical methods used to compare device performance with the human hand. The results section depicts performance of the human hand versus the device. The discussion section describes impact of findings and suggestions for further studies.

## 2 Device Design, Fabrication, and Control

The following chapter covers the design, fabrication, and control of a prosthetic hand simulator for tasks involved in two handed activities of daily living. The focus is on the development of the control method for a myoelectric prosthetic interface that is able to modulate the impedance of the interface according to a priori knowledge. First, the design and fabrication of the prosthetic simulator is described: it includes a single degree of freedom gripper whose movement is modulated by two actuators arranged in an antagonistic pair. Following this, the EMG hardware, signal conditioning, and control algorithms for interpreting user input are described. Finally, the agonist-antagonist position-impedance controller that uses the commanded signal from the EMG and the a priori knowledge of the desired impedance is described.

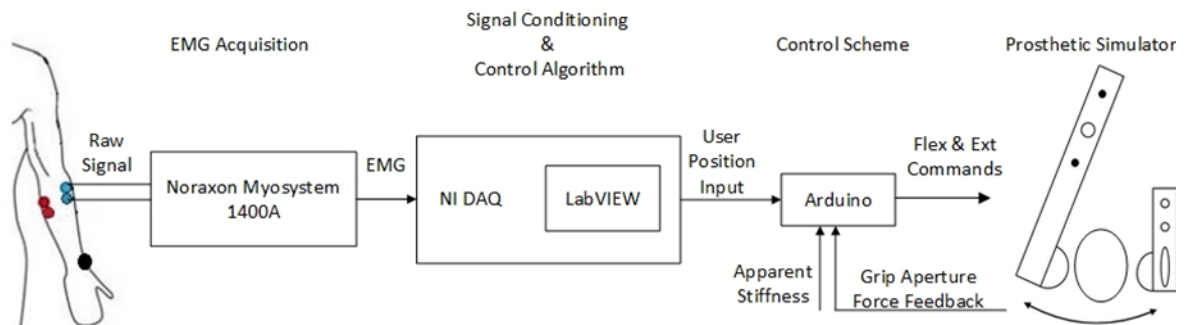

**Figure 2: System Design Overview**

## 2.1 Prosthetic Simulator Design and Fabrication

The prosthetic grasping simulator was designed to replicate a tri-fingered pinching grasp with the index and middle fingers moved as one unit (Figure 3). The index and middle fingers were represented by a simple linkage system that has 1 DOF rotation. The “finger pad” for contact with the object was made of 3D-Printed PLA and had a cylindrical curvature of diameter 0.65in and a width of 1.00in. The thumb was represented by a vertical, stationary linkage in direct opposition to the “index/middle finger”. Its “finger pad” was also made of PLA and had a cylindrical curvature of diameter 0.75in and a width of 0.5in. This finger pad had a thickness of 0.30in and was mounted on a load cell (Futek LSM200, 10lb capacity) which was mounted perpendicular to the fixed linkage.

The moving arm rotates around an axle coupled to a rotary potentiometer (Midori CP-2FBJ-6, 340 degree travel). Two servo motors (HiTEC HS-5645MG, max torque of 168 oz-in) are arranged in an antagonistic pair, each acting on the link (in opposition) through their own Kevlar cord. One inch above the axle, a Kevlar cord of diameter .038in and breaking strength of 130lbs acts as a simulated flexor tendon tied to a one inch aluminum servo horn to the servo motor representing the “flexor” of the antagonistic pair. One inch below the axle, another kevlar cord acts as the simulated extensor tendon that attaches to the servo motor representing the “extensor” of the antagonistic pair. A steel extension spring with a constant of 18.86lbs/in was placed in series with the kevlar cord between the extensor motor and moving link. The spring allows for the system to shift the operating point by providing varying levels of antagonistic force during the change in grasp aperture.

An Arduino MEGA 2560 microcontroller is used to provide the agonist-antagonist position-impedance control of the prosthetic simulator. The rotary potentiometer is read at a sampling rate of 100Hz, with a position resolution of the link of .044mm/bit. The load cell is read at a sampling rate of 100Hz, with a force resolution of .022N/bit and output is attenuated to 0-5V scale for Arduino acquisition.

The servo motors have internal PID position controllers commanded by Pulse Width Modulation (PWM). The servos attempt to move to an angle correlated with PWM signals between 1025-2100 $\mu$ s. Command signals were updated every 10-40ms. The response of the digital servos used is five times faster than an analog servo. Force is modulated by overlaying a force controller outside the inner position controller and selecting a PWM signal to change the force level.

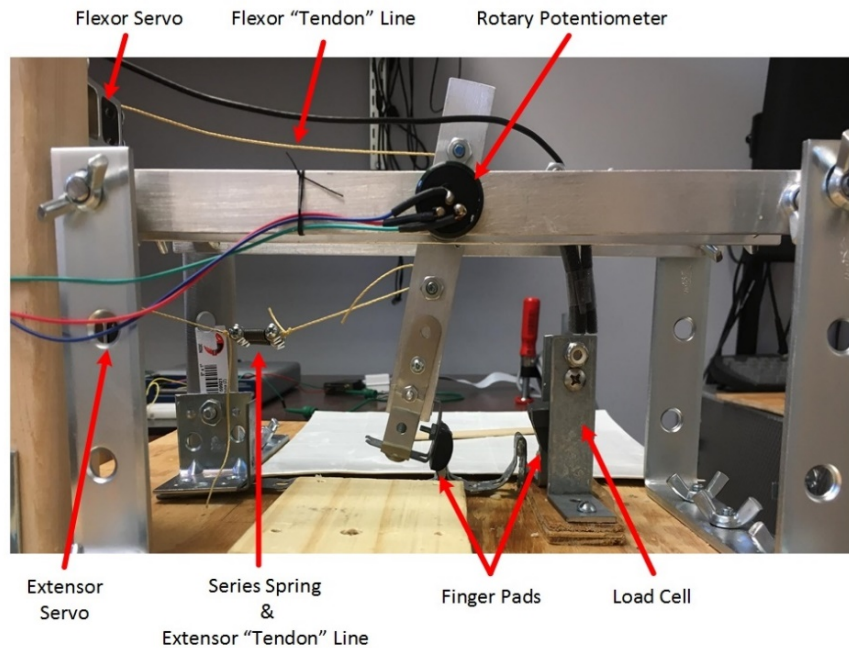
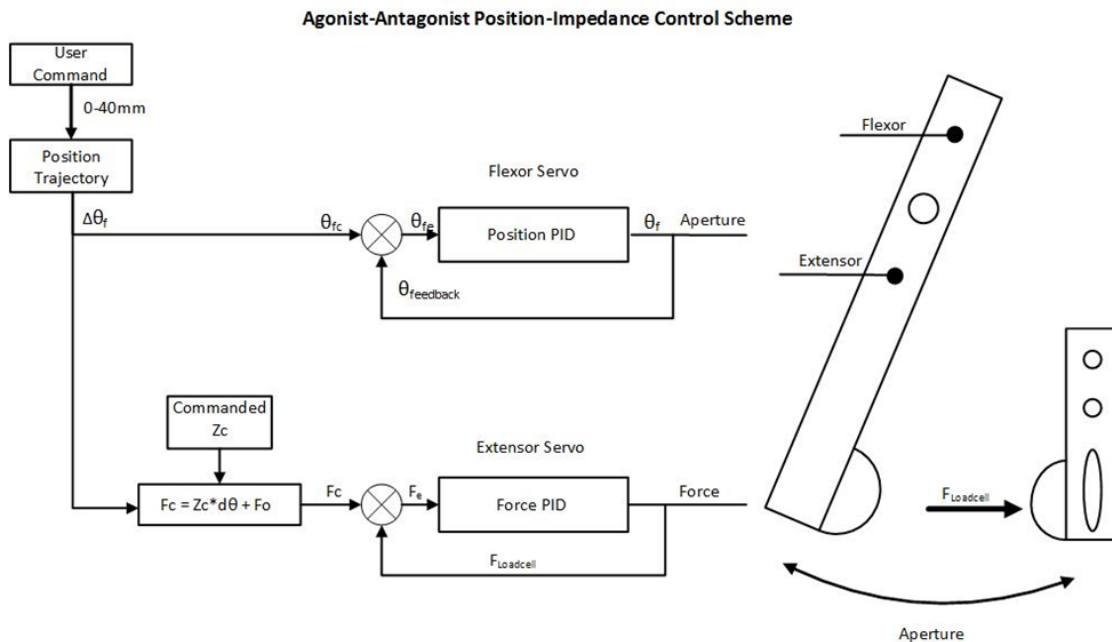

**Figure 3: Prosthetic Simulator**



## 2.2 Prosthetic Simulator Control

With motors set up as an agonist-antagonist pair, the link position and the impedance of the end tip can be independently commanded. An agonist-antagonist position-impedance controller (Figure 4) was utilized to allow the user to control the position of the prosthetic finger (through EMG signals measured from their muscles), while the device automatically adjusted the force level to control the stiffness of the interaction (based on a priori knowledge, which could be from a sensory measurement or memory look-up). The flexor servo worked to reduce the error in the actual grip aperture as compared to the commanded grip aperture. The extensor servo in series with the spring worked against the flexor servo to guide the grip force along a desired stiffness level.



**Figure 4: Agonist-antagonist Position-Impedance Control**

Position controlled Flexor Servo modulates endpoint aperture according to user command. Impedance controlled Extensor Servo acts in opposition to maintain desired stiffness level.

The Arduino MEGA 2560 microcontroller reads inputs from the rotary potentiometer, load cell, and a conditioned EMG signal and uses the information to control the operation of the flexor and extensor motors. The device integrates user input as well as feedback information to provide the desired control.

### 2.2.1 Myoelectric Commanded Position

Two sets of surface electrodes were used to measure “commanded muscle” activity produced by the user. The set placed over the flexor muscles of the wrist (depicted as red in the Figure 5 below) were used to collect user positional input, while the set placed above the wrist extensor muscles (represented in blue) were used only to select the mode of operation. An additional surface electrode (indicated in black in Figure 5) was used as the reference electrode. The EMG signal was acquired and signal conditioning was performed before it was provided as a commanded input for the flexor servo controlling aperture.

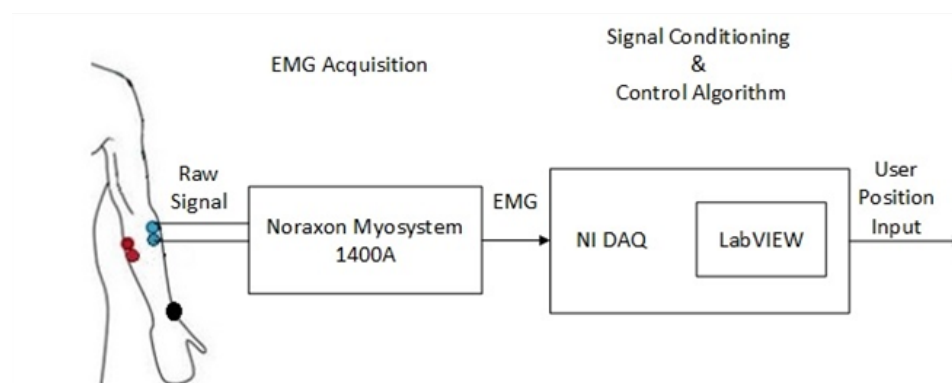

**Figure 5: User Input Overview**

Noraxon HEX Dual electrodes were used to measure the EMG signals which were then collected by a Noraxon Myosystem 1400A (10-500 Hz bandwidth). The system amplified the EMG signal by a gain of 5000 and bandlimited the signal between 10Hz and 500Hz. Two channels of EMG were acquired: one channel reading from the wrist flexors for controlling movement intention and the other reading from the wrist extensors to allow the user to switch modes of operation. The reference electrode serves as a point of comparison for the relative voltage of the other electrodes. It was placed away from the other electrodes on the more electrically neutral bony portion of the user's wrist. The analog output from the Noraxon Myosystem 1400A ranged from +/- 5 Volts.

The analog output of the Noraxon Myosystem 1400A was provided to a computer through a National Instruments USB-6343 DAQ board (with a resolution of  $10.68\mu\text{V}$  and sampling rate of 2.5kHz), which was programmed using LabVIEW. The signal was band limited with a second order Butterworth bandpass filter with a low frequency cut-off of 20Hz and a high frequency cut-off of 400Hz. The signal was then rectified using a 100ms RMS filter to retrieve an envelope of the signal. Finally, the signal was then normalized to a scale between 0 and 100 to address variations in maximum signal strength between users due to anatomical variations.

A LabVIEW VI was developed to allow the experimenter to adjust EMG thresholds to account for user muscle activity patterns and select the mapping between the EMG signal measured and the command to be used by the subsequent control algorithm. A dial allows for simple switching between three mappings: binary ON-OFF, linear, and proportional nonlinear. Each algorithm maps the normalized muscle signal to a position command between -40 and 40. Only the flexor muscle signal controls the

position of the device. The extensor is used solely to activate the stiffness determination sequence. The system only selects the greater of the two signals between the extensor and the flexor at any given moment, normally sending only the flexor commands during a device operation. Extensor signals are represented by -1 to -40, while a flexor signal is scaled between 0 and 40.

The proportional nonlinear mapping, explored by (Arenas, 2015) was used in this experiment. The proportional nonlinear algorithm follows an exponential curve based on literature relating EMG signals to EMG force production. The equation was adapted to fit the limits of the servo motors used.

$$(1) \textit{ Position Command} = \pm 41.976 \frac{e^{(-0.001*(x-10)*46)} - 1}{e^{(-0.001*41.976*46)} - 1}$$

The use of this algorithm was shown to cause less physical demand, frustration, and workload from the users than either binary ON-OFF or linear control.

One difficulty with the original algorithm (designed to control a remote control car) applied to ADLs using the fingers is that it is difficult for users to provide a stable signal for these slower tasks: average finger movement speeds for pick and place ADLs are roughly 172 degrees/s, with more controlled movements expected to be even slower (Weir, 2003). Two modifications were made to address this issue. First, a 5 point moving average filter of the output position command signal was introduced to stabilize the user control signal for the intended precision control tasks, where the user often must hold a relatively volatile EMG signal at a stable location to achieve the desired outcome. In addition, a graph and display gauge (Figure 6) served as visual feedback for the user to control the EMG signals at the desired values. The -40 to 40 position command signal is

then mapped onto a 0 to 5 V output to be read by the Arduino Mega, which acts to control the servo motors.

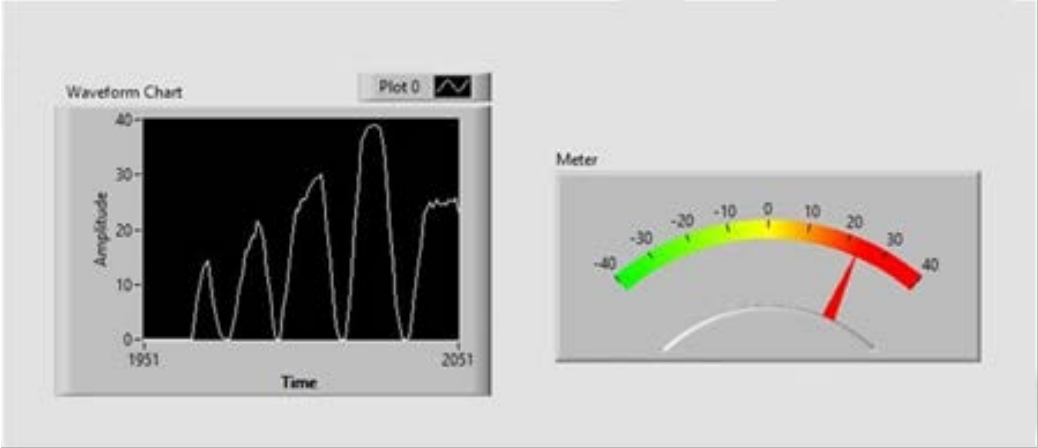

Figure 6: User Training Feedback Display

### 2.2.2 Flexor Servo

The flexor servo operates using an internal PID position controller. The EMG position command signal from the computer is used to specify the target (end point position) the user currently wants to move to.

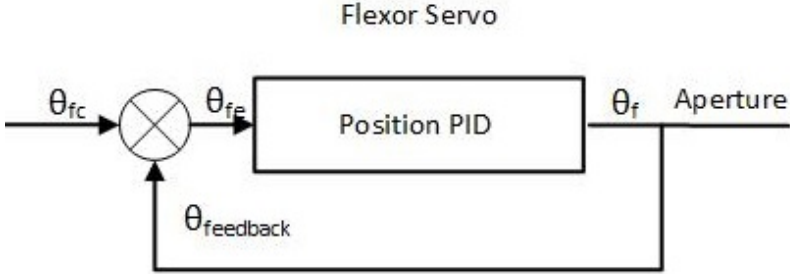

Figure 7: Flexor Position Control

Since position controlled servos were used, the system had no ability to explicitly specify the velocity used to arrive at the target position. However, a consistent average velocity was desired to ensure a smoother force output by reducing the various accelerations introduced when the servo moves to reduce different sized positional errors. A larger movement would elicit a larger servo response, while a smaller movement would elicit a smaller response attempting to reduce the error. In order to achieve an approximately constant velocity during movement regardless of the desired total position change, the trajectory was broken up into a series of smaller, timed position commands of equivalent size. Depending on the size of desired aperture change, a series of step sizes and their respective timing were created. The flexor servo was commanded to move according to the step size specified at timed intervals until the entire desired movement was achieved.

Due to limitations in the resolution of the servo input command, a velocity of  $1^\circ/10\text{ms}$  was chosen. The maximum allowable flexor position change was  $60^\circ$  corresponding to a linear aperture change of 40mm. The created trajectory was used to convey user movement intent to the flexor's internal position controller which acted to modulate the endpoint position of the device.

### 2.2.3 Extensor Servo

The extensor servo is controlled by impedance control. An a priori estimate of object stiffness is used to select a device impedance value. This is used to provide a set point, which determines the force requirement for the force controller used to modulate link movement. The force controller alters the PWM commands to the servo in order to control the endpoint force during the interaction.

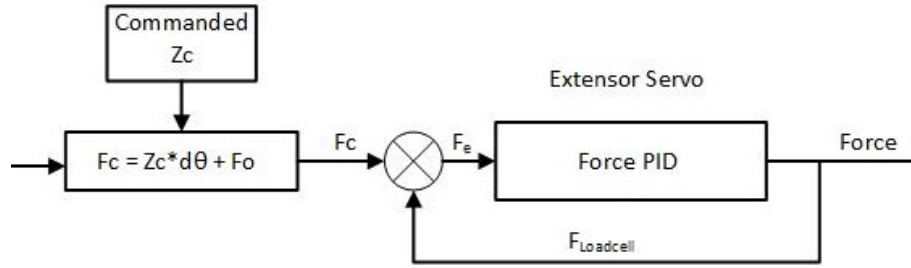

**Figure 8: Device Impedance Controller**

The set point determines the commanded force requirement,  $F_c$ , for a given type of motion commanded by the trajectory function. For interacting with an object, this is given by the commanded stiffness,  $Z_c$ , the object deformation,  $X_c$ , and the currently measured interaction force:

$$(2) \quad F_c = X_c * Z_c + F$$

The currently measured interaction force,  $F$ , is provided by the load cell on the stationary link: as contact is made with the link oriented vertically (right link in Figure 8), contact force is primarily along the primary axis of the load cell. As the stationary link does not move, deformation of the object,  $X_c$  can be measured by keeping track of the movement of the rotating link after the detection of contact. Contact was detected by exceeding a threshold of 1.557N. The commanded position is used instead of the measured position to prevent instability in the force set point trajectory that can arise due to extensor servo activity. Object stiffness is estimated prior to normal device operation and is used to guide the interaction.

A force PID controller is used to move the extensor servo. It uses a proportional on measurement term,  $K_p$ , scaled to an a priori apparent stiffness estimation in order to guide the force of the interaction along a desired path, while reducing overshoot.

$$(3) \quad \mathbf{Output} = K_p[F(t) - F_{init}] - K_I \int e(t)dt + K_d \frac{de(t)}{dt}$$

The proportional on measurement term differs from traditional PID by changing what the proportional term  $K_p$  modifies. Instead of observing the error, the current value of the force input,  $F(t)$  and the initial contact force during hand closure,  $F_{init}$  are used. This modification causes the proportional term to be nonzero at the set point which helps to avoid overshoot normally caused due to integrating term while the other terms are zero. The proportional term acts as a resistive force by increasing the activation of the antagonistically oriented extensor motor. The integral term,  $K_i$ , allows additional force application at the endpoint by decreasing extensor motor activation. The derivative term provides additional disturbance rejection. The output controlled the PWM signal sent to the Extensor Servo, which modified its position to alter the endpoint force.

The device was manually tuned to follow the force set point in a manner that minimized error in the force trajectory and avoided overshoot. The  $K_p$  parameter was adjusted based on the desired stiffness level using the relation below. The equation was created following a lookup table developed from manual parameter testing.

$$(4) \quad Kp = 183.75 * z^2 - 105.66 * z + 18.607$$

Tuning parameters were set at  $K_i=25$  and  $K_d=.085$  to provided additional disturbance rejection.



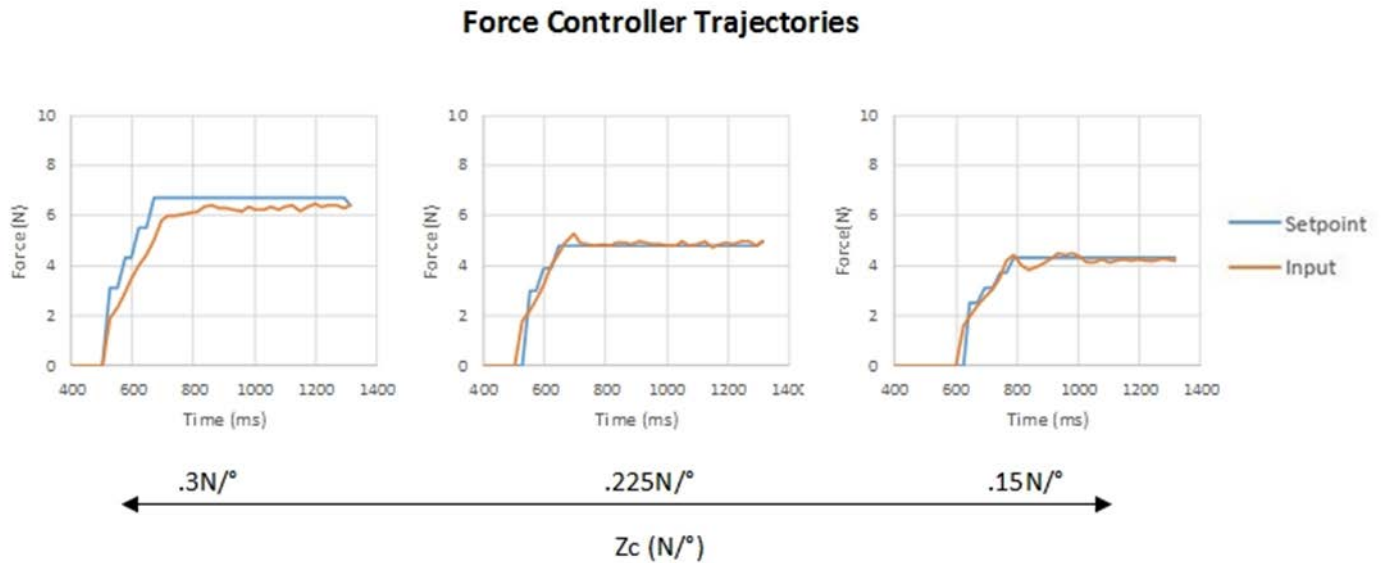

**Figure 9: Force Controller Trajectories**

Device force controller response using a pink tube over a range of commanded stiffness values.

## 2.3 Device Characterization

The system's stability was tested over a range of commanded stiffness values between  $0.1 \text{ N/}^\circ$  and  $0.4 \text{ N/}^\circ$  (Figure 9). At each commanded stiffness value, the device performed a closing and opening motion representing user input. Ramp functions representing user commands to completely close and open the hand were sent to the device to control the motion of the flexor servo to squeeze a tube within the device's grasp. Feedback from device sensors was collected and used to evaluate force controller performance with an emphasis on seeking to minimize overshoot and error.

System performance data was collected from eight attempts at each commanded stiffness level. This process was performed using three different tubes in order to test controller ability to adapt to different compliant tubes. The device stiffness output,  $Z_r$  was observed for different commanded stiffness commands,  $Z_c$ .

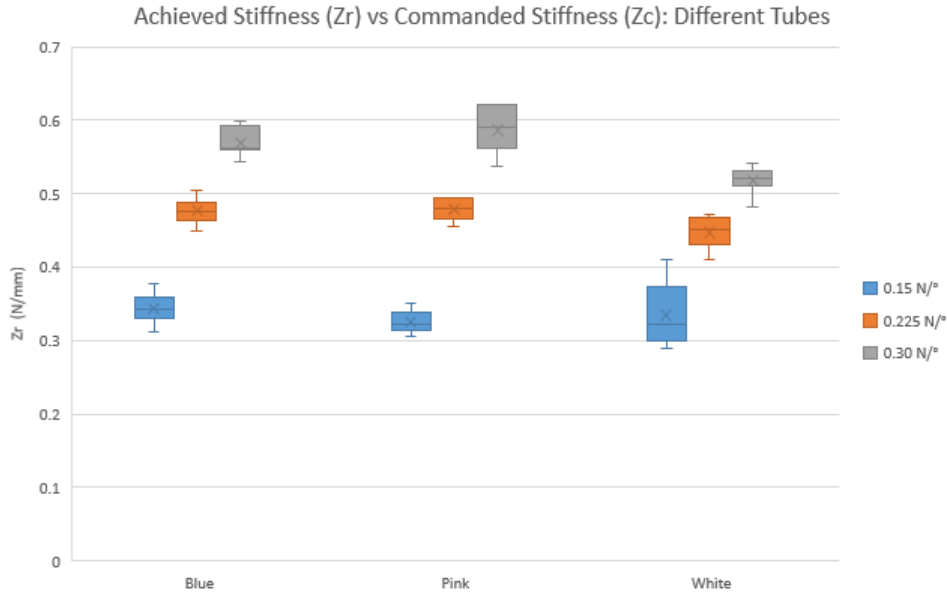

**Figure 10: Comparison of Achieved Stiffness vs. Commanded Stiffness**

Observed stiffness values in response to commanded stiffness value for each tube type.

Input commands between  $.15\text{N}/^\circ$  and  $.3\text{N}/^\circ$  were consistently stable, minimizing overshoot and error. Commands above this range introduced instability due to the breaking of contact force as the extensor servo began to overpower the flexor servo, while commands beneath this range were limited by an inability to apply additional contact force using the unidirectional extensor actuator. The device is capable of reliably achieving a range of controlled stiffness values from  $.3\text{N}/\text{mm}$  to  $.55\text{N}/\text{mm}$  given an input stiffness command between  $.15\text{N}/^\circ$  Flexor to  $.3\text{N}/^\circ$  Flexor regardless of the tube selected (Figure 10).

## 3 Assessment of Agonist-Antagonist Position-Impedance Controller

This chapter describes the design of the experiment that was used to assess the performance of the developed antagonistic position-impedance controller for controlled interaction with a compliant object. The prosthetic simulator, described in Chapter 2, was used as a testbed for the prosthetic hand. The task chosen was based on one of the activities of daily living (ADL) in which controlled forces are needed to extrude paste from a tube for use by the healthy hand. This chapter first provides details of the task to be performed and the task set-up. It then describes how the a priori information about object stiffness was obtained, as needed by the antagonistic position-impedance controller. Finally, it describes the experimental method for the actual assessment of performance. Performance of the proposed controller is compared with performance of a human hand executing the same task.

### 3.1 Bimanual Task

Controlled extrusion from a tube is a common component of bimanual ADLs. For example, in personal hygiene, individuals may need to squeeze a reasonable amount of shampoo, cream, sun screen or toothpaste from a tube onto the healthy hand or a tool held by the healthy hand. The healthy hand is then used for the more dexterous component involving application to the body, hair or teeth. Controlled extrusion from a tube may also be needed for meal preparation, home repairs and other applications. These tasks requires the user to use the prosthetic to interact with an object that has a

deformable surface and changing content in a controlled manner. Improper use of force during this task can cause excessive extrusion of a paste. To see how the developed device compares with the human hand, an ADL station was used as a test environment for both conditions. Three varieties of pastes were also created for testing to examine variations with different paste material properties.

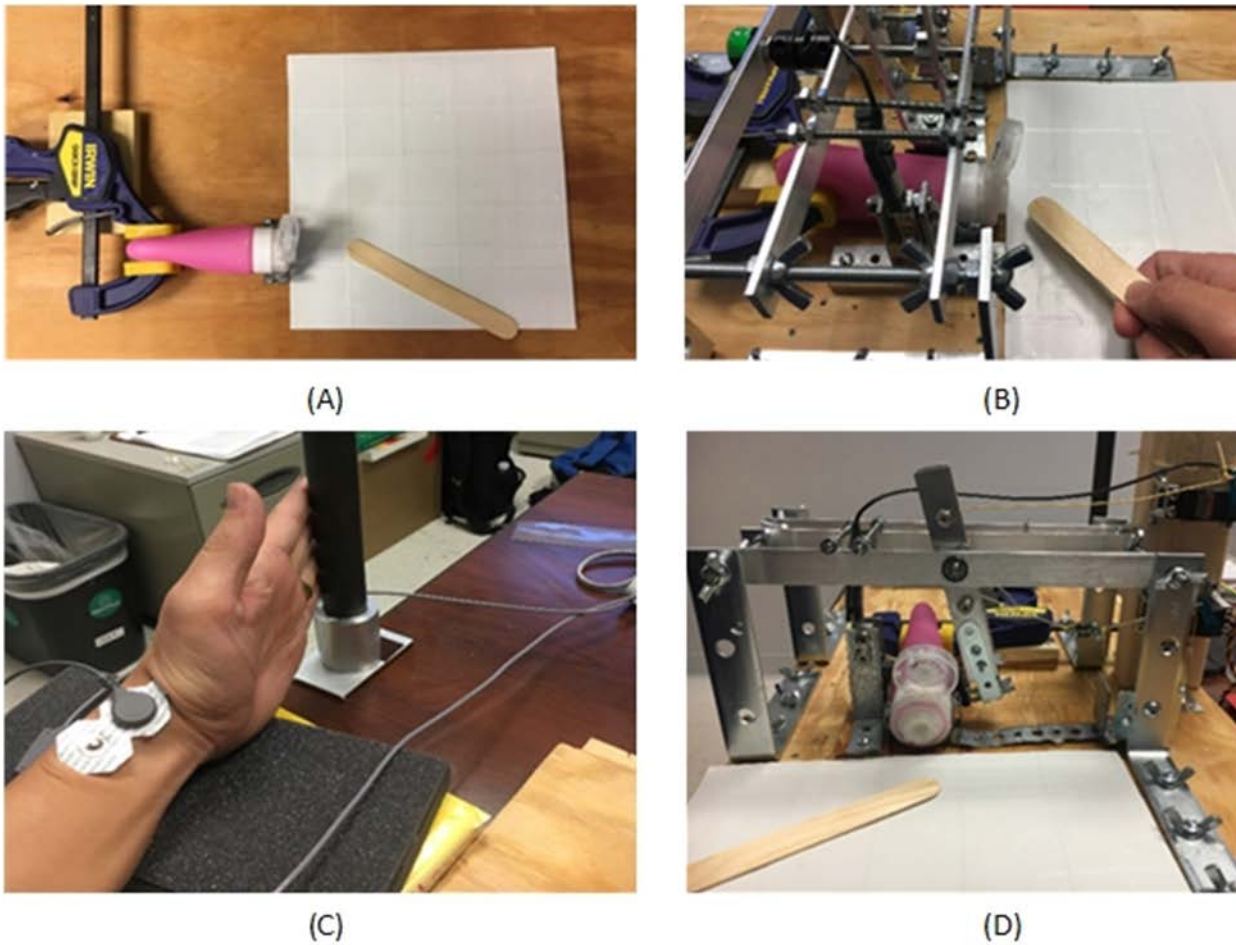

**Figure 11: ADL Stations Human Hand vs. Device**

### 3.1.1 ADL Station

The ADL station consists of a wooden platform on which the task is to be performed (Figure 11, A and D). For the task set-up, a silicone rubber tube with one of three pastes in it is held with a clamp positioned over a removable mat. Figure 11-A is the layout for trials involving the human hand. Figure 11-D is the layout for trials involving the testbed device. A wooden popsicle stick is supplied for the subject to place the extruded paste for each trial.

The volume standard of 1.1cm<sup>3</sup> and a popsicle stick with an equivalent volume were placed on the platform to be within sight of the user during the task.

A foam arm rest and a post (Figure 11-C) are used for the trials involving the testbed device for acquiring the surface EMG signal from the muscles. The foam arm rest is used to keep the arm comfortable in the same position. The post is used so that a subject is able to more easily contract their muscles while keeping their arm stationary.

### 3.1.2 Tube Preparation

A set of silicone tubes of the same size were filled with different types of pastes. The different tube colors (pink, blue and white) corresponded to the three different types of pastes. The paste in the pink tubes was composed of 1 cup of soap shavings and 90mL of milk of magnesia mixed at room temperature and then allowed to sit. This paste type takes on a consistency similar to a meringue, with a frothy, foamy consistency. The paste in the white tubes was composed of 1 cup of soap shavings, 4g of soy wax, and 90mL of canola oil. The ingredients were placed in a glass jar and heated in a water bath over

medium heat for 15 minutes. After this time period, the ingredients were melted. The jar is then removed from heat, the materials mixed and then allowed to cool. After the material was cool, it was used to fill the tubes. This paste type has the consistency of a gel like paste. The blue tube paste was composed of 1 cup of soap, 8g of soy wax, 30mL of canola oil, and 30mL of milk of magnesia. The ingredients are placed in a glass jar and heated for 15 minutes over medium heat within a water bath until the contents melt. The jar is then removed from heat, the mixture stirred and left to rest for at least one hour before filling a tube. The blue tube's paste is thicker than the others but still creamy. It can be likened to a custard.

Before use in a trial, the paste in the tube to be used in that trial was emptied out of the tube, remixed, and stirred to ensure no clumps had formed. The tubes were refilled and the air was removed by squeezing the tube and retaining the paste. If the pastes in the tubes became old and solid, they were restored through reheating in a warm water bath at 30°C for 20 minutes, remixed, and allowed to return to room temperature.

## 3.2 A Priori Determination of Stiffness

For interaction with a particular tube type, the a priori value of stiffness to be used for the impedance controller is needed. This value is determined before normal device operation by using the device to perform two shallow palpations by increasing commanded flexor angle by six degrees after moving into contact with the tube. During these palpations, the contact force and the position of the contact point are collected. From each palpation, the apparent stiffness is calculated by:

$$(5) \quad Z_{\text{apparent}} = - \frac{\Delta \text{Force}}{\Delta \text{Position}}$$

Where  $\Delta \text{Force}$  is the difference in force at the end of the commanded movement and initial contact force, and  $\Delta \text{Position}$  is the difference between aperture width at the end of the commanded movement and at initial contact. The a priori apparent stiffness to be used in the trial is the average of the values calculated from the two palpations.

### 3.3 Experimental Methods

Six right handed subjects (two female and four male) were recruited to participate in the study through convenience sampling. The experiment occurred during a single session lasting between one and two hours. Subjects were asked to perform the bimanual ADL squeezing task in two ways: (1) using the prosthetic simulator and (2) using their left hand (the non-dominant hand for all participants). For the operation mode using the controller with the prosthetic simulator: the subjects were tasked with voluntarily squeezing a specified amount of fluid ( $1.1\text{cm}^3$ ) from one of the tubes onto a popsicle stick using the simulated prosthetic device and controlling the grip aperture through EMG signals from their wrist flexor and extensor. For the operation mode with the human hand, a tri-fingered pinch grasp was used with the subject's left hand to apply pinching pressure to the tubes in a comparable way. For each trial, the extruded amount was recorded and compared with the requested amount ( $1.1\text{cm}^3$ ). The response time was also recorded, starting from the prompting by the experimenter and ending when the subject finished applying paste to the stick. The amount of paste spilled was also to be recorded, although none of the subjects ended up spilling any paste during the trials.

### 3.3.1 Experimental Design

The experimental design was a within subject design with factors: operation mode (prosthetic controller versus human hand), tube type (red, blue, white) and repetition (1, 2, 3). The trials were blocked on operation mode, with the order counterbalanced across subjects. Half of the subjects performed a block of trials using their own hand first, while the other half started with the device. Each block of trials consisted of 9 attempts using tubes filled with pastes of different consistencies. Each type of tube was tested 3 times over the course of the block. The order of the tubes being presented was blocked on repetition. Within each block, presentation of the 3 tube types was randomized using a random sequence.

### 3.3.2 Experimental Procedure

When scheduling subjects for the study, it was requested that they avoid wearing lotion to avoid possible interference with EMG signals and that they would need to remove any watches. When the subject arrived, the experimental procedure was explained, and they were asked to give their consent to participate in the IRB approved experiment. Then the subjects were prepared for the first study block: either a squeezing task utilizing their own hands or the prosthetic simulator. Subjects then completed the entire block with the given mode of operation. The subjects were then prepared for the second study block: the other of the operation modes. Subjects then completed that block as well.

#### ***Human Hand Trials***

The subject was asked to sit in front of the experimental apparatus depicted in Figure 11-A, consisting of a wooden board with one of the tubes placed in a holder, a clamp used to pretension the tube to a point just below the break loose and extrusion



point, and a mat used to collect any spilled paste. Subjects were asked to perform a squeezing motion on a tube, between the clamp and the plastic neck of the tube, using a tri-fingered grasp with their left hand. They were asked to extrude a specified amount of paste onto one side of a popsicle stick held with their right hand. A reference volume of paste was displayed in both a container and on top of a popsicle stick placed on the table. Subjects were told that they could use the popsicle stick to cut off the flow of the paste at the desired amount and scrape residual paste off the nozzle of the tube. However, they were not to collect any paste that missed the stick and fell onto the tray.

Before each trial, a small amount of paste was extruded by the experimenter to ensure smooth extrusion. In the event of a clog, clump, or failure in extrusion, the cap was removed and cleaned and the paste was stirred using a wooden stick. Then the tube was pretensioned to a point just below the break loose and extrusion point. A stick marked with tube color, the trial number, and the weight was handed to the subject, and they were asked to squeeze out the desired amount of paste onto the popsicle stick. The trial was timed using a handheld timer starting when the experimenter prompted the subject to start and ending once the subject finished putting paste on the stick and specified they were finished by returning the popsicle stick. After each trial, the experimenter weighed the amount of paste on the popsicle stick. The volume was later calculated using both this measurement and the known density of the given paste from each tube (obtained at an earlier time using the volume standard of each paste). Any paste that spilled, was to be collected and measured. However, no paste was spilled by any of the subjects.

## ***Prosthetic Control Trials***

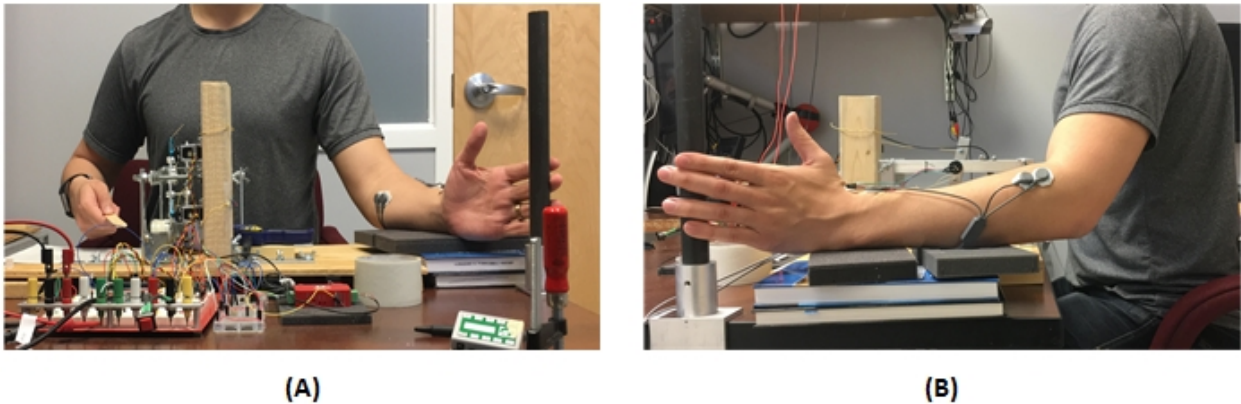
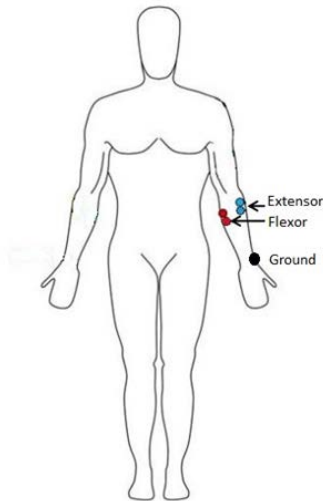

**Figure 12: Subject Position for Prosthetic Control**

### Subject Preparation

The subjects were seated in a chair in front of the ADL apparatus, depicted in Figure 12-A, and the simulated myoelectric prosthetic device that was positioned to grasp a tube. For generation of EMG signals using muscle contractions, the subject's left arm was placed to the left side of the device with their forearm on a foam rest and the pads of their fingers made contact with a vertical post (Figure 11-C, Figure 12-B). Subjects were asked to maintain their left arm position constant throughout the trials to ensure consistent EMG activation levels. Their right arm was placed to the right side of the device in a way that allowed for manipulation of a popsicle stick in front of the tube holder.

The wrist flexors and extensors of the left arm were used to control the change in the grip aperture of the prosthetic simulator. Disposable, self-adhesive electrodes were placed in standard locations approximately 5cm distal to the elbow (Figure 13), while a reference ground lead was placed at the subject's wrist (De Luca, 2002). The electrodes were connected to the Noraxon Myosystem 1400A which was connected to a computer (Section 2.2.1).



**Figure 13: Standard Lead Locations for Flexor and Extensor EMG**

### System Calibration

Once the electrodes were attached, the system was calibrated to recognize flexion and extension signals from the subject's muscles as opposed to noise. A LabVIEW Virtual Instrument (Figure 14) allowed the experimenter to adjust the thresholds of the normalized signal to correlate device positional response to the user's muscle signals. This was necessary since muscle signal strength varies depending on the user.

For correct calculation of the EMG signal during the experiment, maximum activation threshold of the flexor and the minimum activation threshold of the flexor was needed. A calibration routine was used to obtain these values. The subject was asked to first relax their muscles and then maximally contract their wrist flexors. From measurement of the EMG signal in those two contraction states, the initial baseline and maximum activation thresholds were set, respectively. The maximum threshold corresponded to a maximally commanded closure of the grasp. To prevent muscular fatigue during use and allow for users to consistently have access to the full input

command range, maximum thresholds were adjusted to 80% of their absolute maximum contraction. The minimum flexor threshold referred to a completely open grasp. The threshold was placed above the resting baseline EMG signal to prevent unintentional movement of the device. For this experiment a nonlinear control scheme was used to translate normalized EMG activation level (0-100%) to a position command signal (represented on the gauge as 0-40, corresponding to 40mm aperture range). Visual feedback was not provided to the user during threshold setting, but was provided to the user later during training period (described during the next section).

The extensor signal was used only to activate the a priori measurement of object stiffness. As a result, the threshold minimum and maximum were both set to roughly half of the maximum voluntary contraction for the extensor. The reasoning for this was so that a wrist held backwards would continuously signal -40 and have an activation threshold beyond what could occur through accidental co-contraction of the wrist during flexion motions. This was important to ensure that the a priori measurement sequence would only be initiated intentionally.

The threshold levels were readjusted if the control signal was producing unintentional movements (minimum threshold too low) or if subjects struggled to provide enough contraction to reach the entire command range (maximum threshold set too high).



**Figure 14: LabVIEW VI Interface**

### Training Period

After calibration, a short training period was used to familiarize the subject with the control algorithm. The LabVIEW VI was shown to the subject, and they were asked to observe the graph and gauge while performing a trial. The graph displays the commanded position from 0 to 40 on a continuously scrolling waveform chart. The gauge displays from -40 to 40, representing the position output signal from the proportional nonlinear controller, with negative values specifying extensor signals and positive values specifying flexor signals.

Subjects were first trained to control the EMG signals they generated. They were asked to attempt to reach a series of target values repeatedly by activating their flexor muscles, returning to zero after each activation.

1. Reach target 10, 20, 30, or 40 each ten times in a row
2. Escalating targets starting at 10, 20, 30, then 40 repeating 5 times

3. Descending targets starting at 40, 30, 20, then 10 repeating 5 times
4. Non adjacent Sequence 20, 40, 30, 10 repeating 3 times

Then subjects were then trained to use their extensor to activate the a priori measurement of stiffness. A held extensor contraction at -40 for 3 seconds indicated engagement of the a priori determined stiffness value for the given tube type in the trial. Subjects were asked to demonstrate generating the required signal by holding the EMG signal at -40 for 3 seconds for 5 repetitions.

If the subject was successful and felt comfortable with the methods for using the flexor and extensor in control then they would proceed to testing. Otherwise the device would be re-tuned and the training period would be repeated.

### Trial Performance

The prosthetic testing proceeds almost identically to the human hand experiment, but with the left (non-dominant) hand replaced by the prosthetic simulator. Utilizing their right (dominant) hand to hold a popsicle stick, subjects were asked to collect the squeezed paste on the popsicle stick. Only one side of the stick was to be used. Subjects were again told that they could use the popsicle stick to cut off the flow of a paste at the desired amount and, then, scrape residual paste off the nozzle of the tube. However, they were not to collect any paste that missed the stick and fell onto the tray.

Once the subject understood the instructions, the tube to be used during that trial was pre-tensioned and then placed into the tube holder within the grasp of the device. The device was turned on and the controller software was started. A stick marked with tube color, the trial number, and the weight was handed to the subject. Subjects were

then asked to activate the device's auto-stiffness selection sequence to confirm that it engaged. Once the system recognized the wrist extension signal, an LED (located on the apparatus) turned green and the simulator performed a brief two twitch palpation (Figure 15). During the tube stiffness determination sequence, the subject was asked to relax their arm until the LED turned blue to ensure that no unintended movements would be sent to the device upon activation. At that point, the system parameters were scaled to the measured object stiffness. After successful measurement of the a priori stiffness, users were free to squeeze out the desired amount of paste onto the popsicle stick using the simulated prosthetic device.

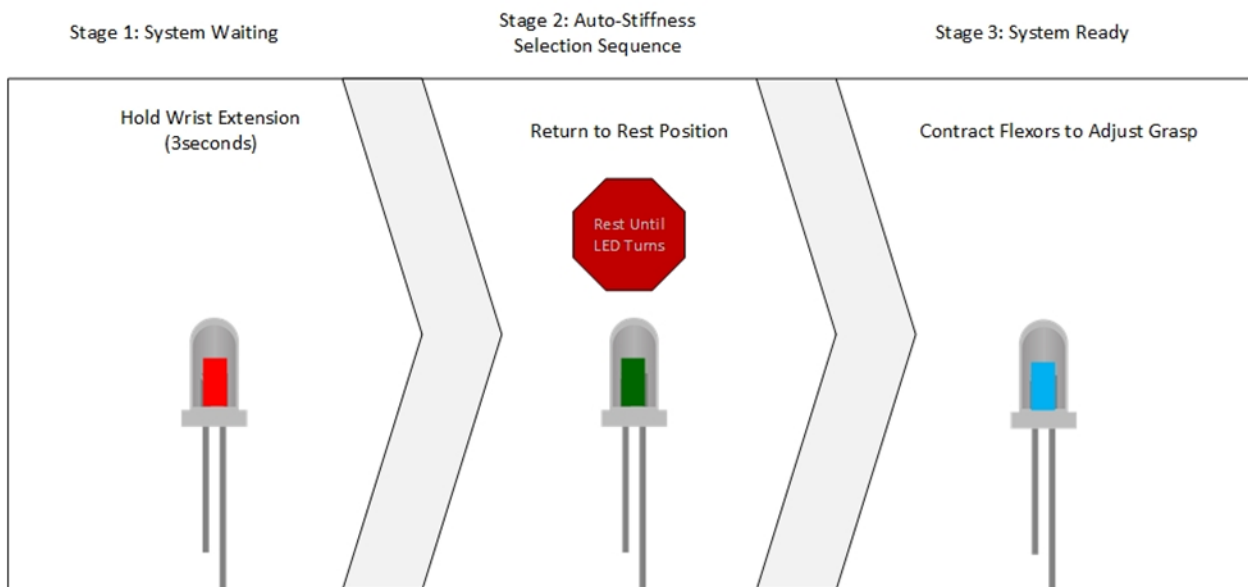

**Figure 15: Device Modes and Indicators**

The task trial was timed using a handheld timer starting at the prompting of the experimenter for the subject to squeeze the tube and ending once the subject finished putting paste on the stick.

A brief pause, no longer than two minutes, was taken between trials to record the performance and reset the apparatus. After each trial, the experimenter would turn off the device, take the popsicle stick and weigh the amount of paste. The volume was later calculated using both this measurement and the density of the paste from each tube (obtained at an earlier time using the volume standard). The time was recorded and any paste that spilled, was collected and measured. Before each trial, a small amount of fluid was extruded by the experimenter to ensure smooth extrusion. In the event of a clog, clump, or failure in extrusion, the cap was removed and cleaned and the paste was stirred using a wooden stick.

### 3.4 Statistical Methods

Two types of statistical analysis were performed. First, generalized estimated equations (GEE) were used to model the response time and the volume error between that squeezed during a trial and the standard (Hanley, Negassa, Edwardes, & Forrester, 2003). Main effects of operation method (human hand or device), tube type (pink, blue or white) and repetition block (1, 2 or 3) as well as two way interactions were included in the initial model. The volume error was determined to be normally distributed and so a normal distribution with an identity link function was used. As times are typically distributed as a Poisson function, a Poisson distribution with an identify link function was used for its model. An exchangeable working correlation matrix was used, as it is the recommended structure for repeated measures in a balanced design. Significance values of  $p < 0.05$  were used to reject the null hypothesis (i.e., that the compared groups were the same): thus, allowing the conclusion that the comparison groups were different. To form the final version of our model, only those main effects that were significant ( $p < 0.05$ ) and



interaction effects for which both the main and interaction effects were significant were included. Further analysis of any significant differences was performed through targeted pairwise contrasts adjusting for multiple comparisons using the least significant difference adjustment in SPSS.

As the main effect we were most interested in (the mode of operation) was not significantly different, we also tested for equivalency between the two conditions using the TOST equivalency test using two one-sided t-tests using SAS (Mascha & Sessler, 2011). The two hypotheses are to test if the difference between the conditions lies outside the bounds of equivalency. Rejection of both hypotheses is needed to assume equivalency. A statistical significance of  $< 0.05$  were used to reject a hypothesis. This type of test did not have a nested design. However, pairs of values were matched on all other effects to factor out commonalities, such as with a matched pair t test.

## 4 Results

The errors in the extruded volume compared to the standard expected to be extruded and response times were collected and used to gauge user performance in the bimanual ADL task during each trial. As all subjects were able to complete the entire set of trials for all conditions and none of the subjects spilled any of the paste, the amount of paste spilled was not included in the analysis. The primary comparison was comparing the conditions of using the controller with the prosthetic simulator (device) as compared to the human hand of the subject. The other independent variables were: the material within the tube (tube type) and the repetition block the trial was in. First, differences were compared using Generalized Estimating Equations (GEE) using SPSS statistical software. Then equivalency was considered for the primary comparison using a two one-sided t-test (TOST) equivalency analysis in SAS.

### 4.1 Volume Extrusion Error

#### 4.1.1 Analysis of Differences

A GEE model (Table 1) was used to compare the volume extrusion error variation with trial condition considering the main effect of mode of operation (human hand/device), tube type (corresponding to tube colors: blue, pink and white) and repetition block (1, 2 or 3).

<b>Model Information</b>		
Dependent Variable		Error
Probability Distribution		Normal
Link Function		Identity
Subject Effect	1	Subject
Within-Subject Effect	1	Human Hand / Device
	2	Tube Type
	3	Repetition
Working Correlation Matrix Structure		Exchangeable

**Table 1: GEE Model Volume Extrusion Error**

The results of the analysis are given in Table 2.

<b>Tests of Model Effects: Volume Extrusion Error</b>			
Source	Type III		
	Wald Chi-Square	df	Sig.
(Intercept)	1.319	1	.251
Human Hand/Device	.006	1	.940
Tube Type	10.345	2	.006
Repetition	107.558	2	.000
Human Hand/Device * Tube Type	1.884	2	.390
Human Hand/Device* Repetition	1.849	2	.397
Tube Type * Repetition	12.489	4	.014

**Table 2: Test of Model Effects: Volume Extrusion Error**

The mode of operation (human hand versus device) was not shown to be significant (Wald  $\chi^2(1, 53) = 0.006$ ,  $p = 0.940$ ). Thus, the null hypothesis could not be rejected, although it could not be accepted either. Therefore, a test of equivalency between the two conditions was made using a TOST test (Section 4.1.2).

The only effects that were significant were tube type and repetition block (Wald  $\chi^2(2, 53) = 10.35$ ,  $p = 0.006$  and Wald  $\chi^2(2, 53) = 107.56$ ,  $p < 0.0005$ , respectively), as well as the interaction between these two effects (Wald  $\chi^2(4, 53) = 12.49$ ,  $p = 0.014$ ). Therefore, the final GEE model only included these terms (Table 3).

### Tests of Model Effects

Source	Type III Wald Square	Chi- df	Sig.
(Intercept)	1.319	1	.251
Repetition	107.558	2	.000
Tube Type * Repetition	12.489	4	.014
Tube Type	10.345	2	.006

**Table 3: Volume Extrusion Error: Final Model**

Figure 16 through 18 show the estimated means for the responses for repetition block and tube type, as well as their interaction. Error bars indicate standard error.

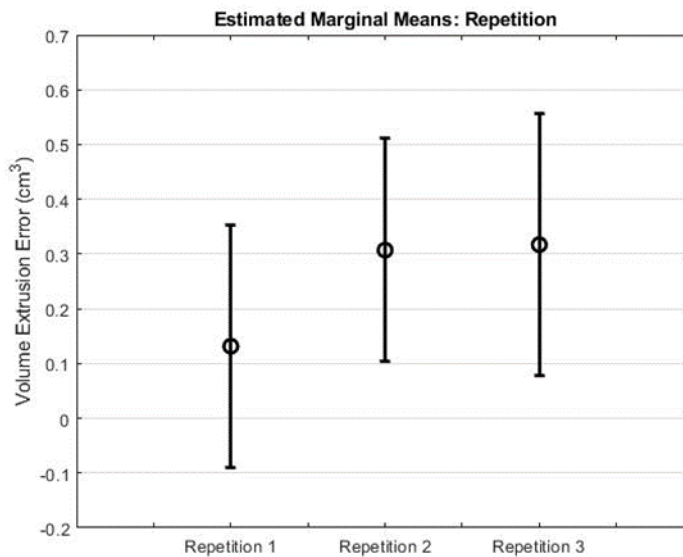

**Figure 16: Volume Extrusion Error: Estimated Marginal Means: Repetition**

Figure 16 suggested that repetition blocks 2 and 3 are more similar to each other than to block 1. Pairwise comparisons were made, adjusting for multiple comparisons using the least significant difference adjustment in SPSS, to further understand the effects. Differences were found to be significant between repetition blocks 2 and 1 ( $t(53) = 7.76, p < 0.0005$ ) and blocks 3 and 1 ( $t(53) = 3.23, p = 0.001$ ) but not blocks 2 and 3. This suggests that subjects may have been more careful in the first block of trials than in the other blocks of trials. The lack of statistical difference between repetition 2 and 3 suggests together they may be more reflective of realistic use than repetition 1.

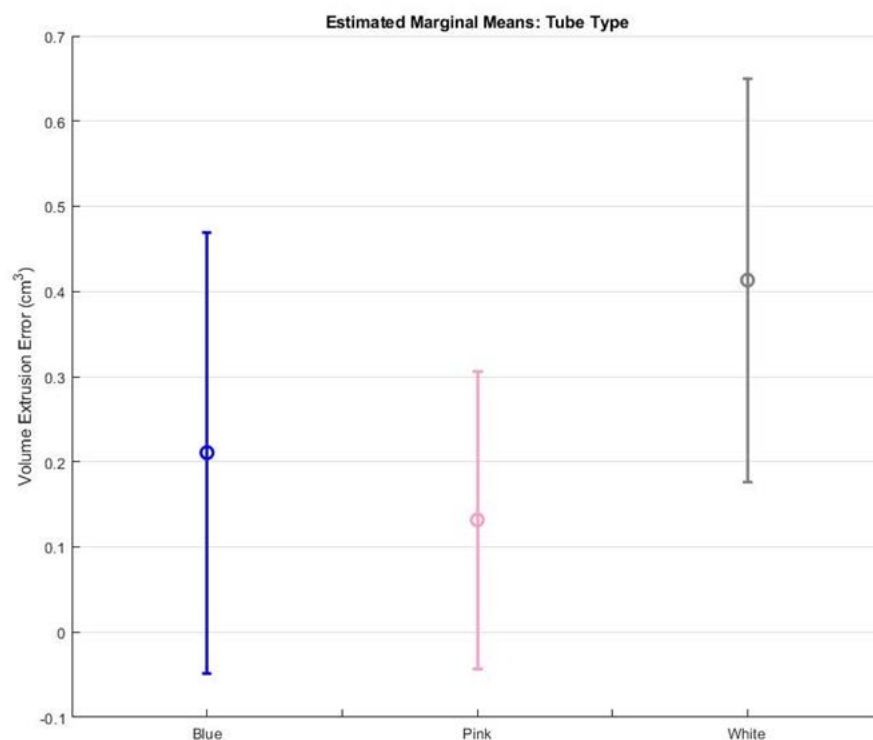

**Figure 17: Volume Extrusion Error: Estimated Marginal Means: Tube Type**

Figure 17 suggested that the material in the white tube (gel like paste) resulted in a larger performance error in volume than the other two tube types (blue = custard, pink = meringue). Pairwise comparisons were made to further understand the effect, again adjusting for multiple comparisons using the least significant difference adjustment in SPSS. Differences were found to be significant between the white (gel) and pink (meringue) tubes ( $t(53) = 3.05, p = 0.002$ ) and the white (gel) and blue (custard) tubes ( $t(53) = 2.18, p = 0.029$ ) but not the pink (meringue) and blue (custard) tubes ( $t(53) = 0.78, p = 0.434$ ).

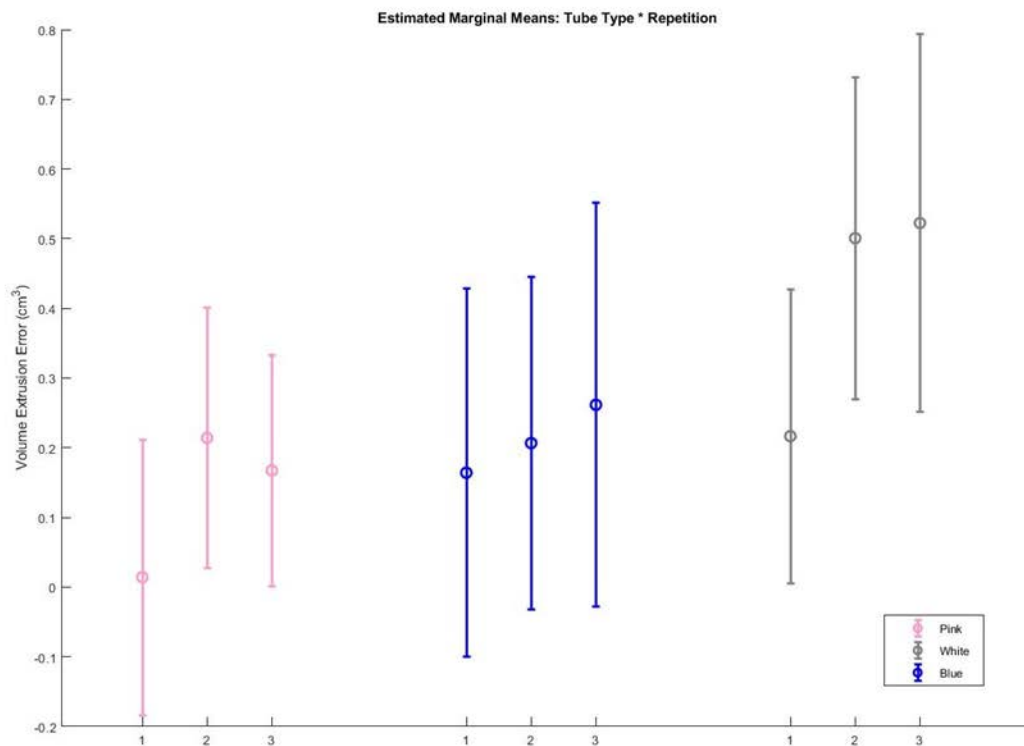

**Figure 18: Volume Extrusion Error: Estimated Means: Tube Type \* Repetition**

Figure 18 shows the estimated marginal means as a function of tube type and repetition block. The interaction term considers the effect after the two main effects (tube type and repetition) are removed. Figure 18 suggests that there may be an interaction effect in the difference of the first repetition block between the blue tube type and the others. It appears that the blue tube does not have as much of an effect as the others. This seems to be consistent with the pairwise comparisons between block repetitions within each tube type. Although it would be desirable to only analyze repetition blocks 2 and 3 in further analysis, this was not performed due to the significant drop in statistical power in doing so.

As mentioned earlier, Figure 17 and the associated pairwise comparison suggested that the material in the white tube (gel like paste) resulted in a larger performance error in volume than the other two tube types (blue = custard, pink = meringue). It was interesting to consider whether these performance differences may be due to differences in the stiffness value between tube types; (each trial used a priori measurement performed immediately before the experiment with the given tubes for the current subject so this could not contribute to the difference). Although stiffness information of the tubes was not recorded for each trial, information regarding the tube stiffness from 3 different samples of each tube type (color) was observed to provide an idea of the possible apparent stiffness of each type of substance and how it may interact with volume error (Figure 19). Apparent stiffness values were sampled using the device's a priori determination sequence.

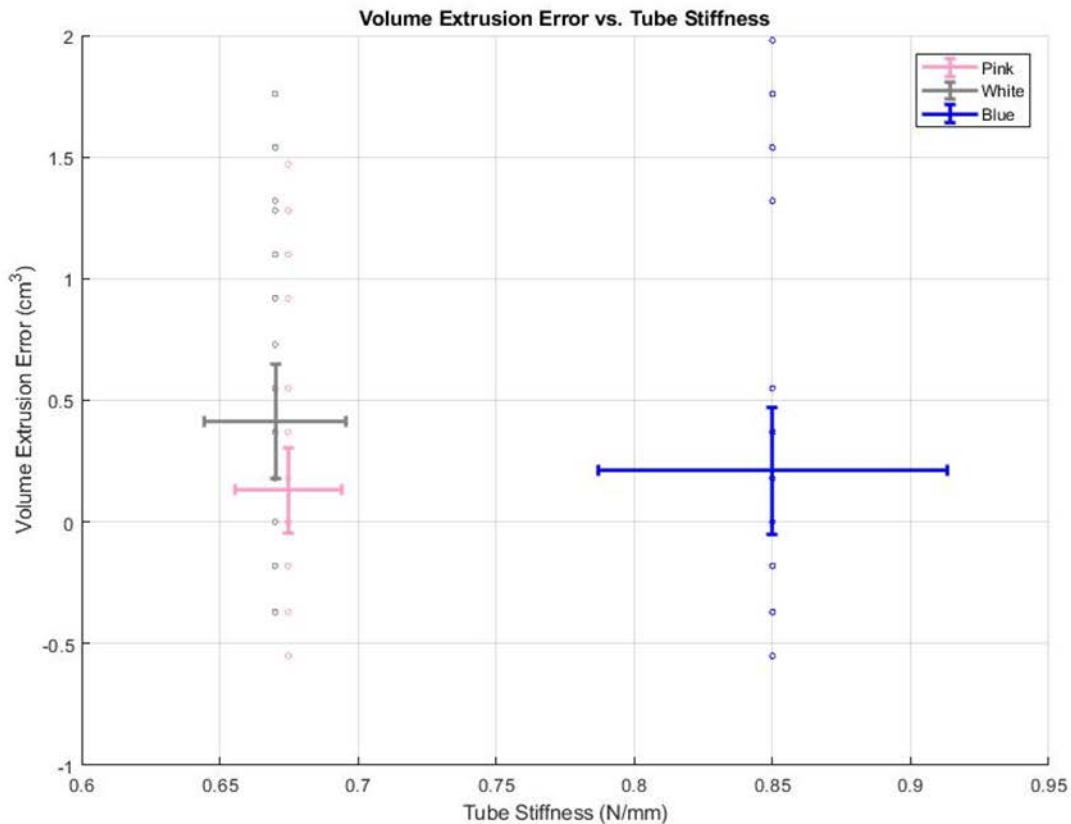

**Figure 19: Volume Extrusion Error vs. Tube Stiffness**

Figure 19 shows that the paste in the blue tube had the most variable apparent stiffness (standard error = 0.0632) of the three substances. The mean apparent stiffness of the blue tube ( $\mu = 0.85$ ) was also higher than either the pink or white tubes. The pink and white tubes have similar apparent stiffness values ( $\mu = 0.674$  and  $.671$ , respectively) and comparable variability (standard error = 0.0192 and 0.0254, respectively). Trials using the white and blue tubes had greater variability in extrusion volume error (standard errors of 0.23650 and 0.25906, respectively) while the trials using the pink tubes had less variability (standard error = 0.17459).



Tests of Model Effects			
Source	Wald Chi-Square	Type III	
		df	Sig.
(Intercept)	2.490	1	.115
Human Hand/Device	.008	1	.930
Color of Tube	18.529	2	.000
Repetition	5215.544	2	.000
Order	5.324	1	.021
Human Hand/Device * Color of Tube	1.884	2	.390
Human Hand/Device * Repetition	1.849	2	.397
Human Hand/Device * Order	2.342	1	.126
Color of Tube * Repetition	12.489	4	.014
Color of Tube * Order	6.173	2	.046
Repetition * Order	304.011	2	.000

Dependent Variable: Error  
Model: (Intercept), Human Hand/Device, Color of Tube, Repetition, Order, Human Hand/Device \* Color of Tube, Human Hand/Device \* Repetition, Human Hand/Device \* Order, Color of Tube \* Repetition, Color of Tube \* Order, Repetition \* Order

**Table 4: Test of Model Effects: Volume Extrusion Error: Order**

To check for order effects, the model was run again where order was coded with a 0 for the Human Hand trials first and 1 for the Device trials first. The order was found to be significant (Wald  $\chi^2(1, 53) = 5.324, p = 0.021$ ). The estimated means for the response for order are depicted in Figure 20. The results suggest that starting with the Device trial block resulted in a larger performance error in volume than beginning with the Human Hand.

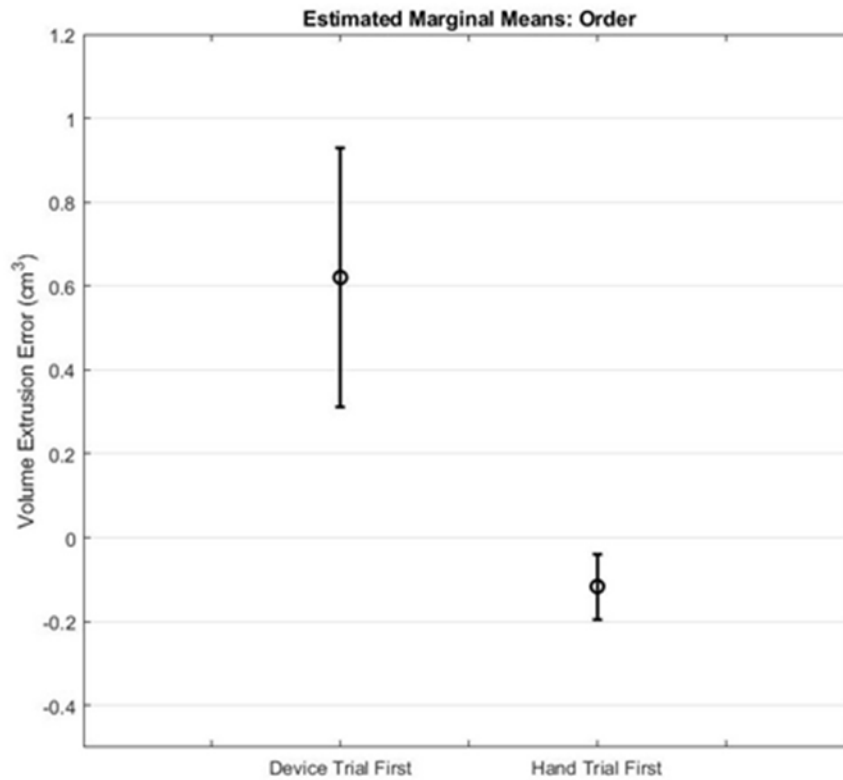

**Figure 20: Volume Extrusion Error: Estimated Marginal Means: Order**

#### 4.1.2 Analysis of Equivalence

The mode of operation (human hand versus device) was not shown to be significant (Wald  $\chi^2(1, 53) = 0.006$ ,  $p = 0.940$ ) in the GEE analysis. However, based on the form of the hypothesis, equivalency between the two conditions could not be concluded. Therefore, a test of equivalency between the two conditions was made using a two-one sided t-test (TOST) equivalency test, executed with SAS. The equivalency bound for error in volume was set to 10% of the  $1.1\text{cm}^3$  volume standard.  $H_0$  was defined to be a negative difference effect more negative than the lower equivalence boundary.  $H_1$  was defined as any positive difference in effect above the upper equivalence boundary

(Figure 21). The figure also shows that the assumption of normalcy of the distribution is a good assumption.

**TOST Level 0.05 Equivalence Analysis: Volume Extrusion Error**

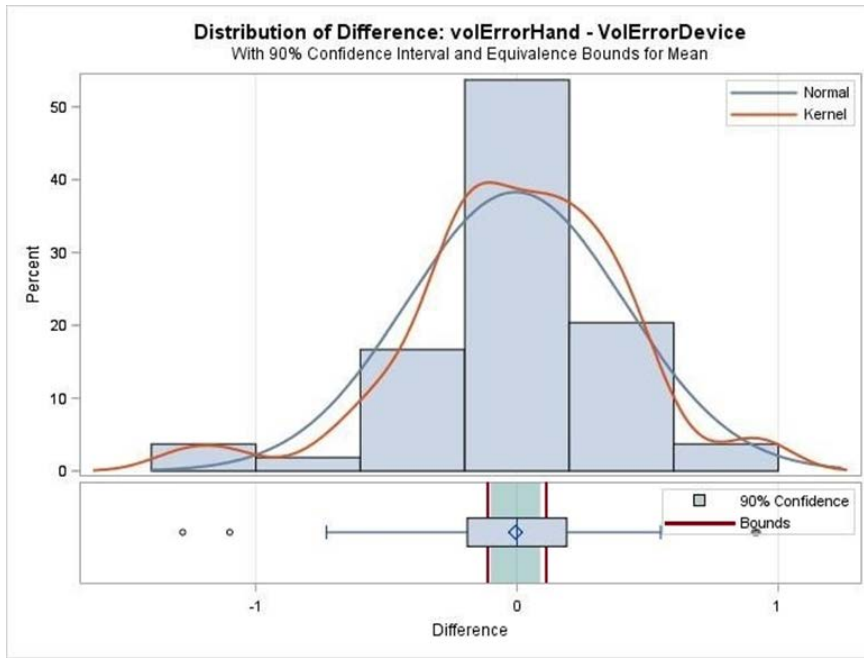

**Figure 21: Distribution of Difference: Volume Extrusion Error**

The results of the TOST analysis showed that the volume extrusion error was equivalent (worst case p value:  $t(53) = 1.84$ ,  $p=0.0360$  for  $H_0$  and  $H_1$ ) whether using the device or the human hand (Table 5).

Mean	Lower Bound		90% CL Mean			Upper Bound	Assessment
-.00593	-0.11	<	0.1009	0.0890	<	0.11	Equivalent

Test	Null	DF	t Value	P-Value
Upper	-0.11	53	1.84	0.0360
Lower	0.11	53	-2.04	0.0230
Overall				0.0360

**Table 5: TOST Equivalency: Volume Extrusion Error**

## 4.2 Response Time

### 4.2.1 Analysis of Differences

A GEE model (Table 6) was used to compare the response time variation with trial condition considering the main effect of mode of operation (human hand/device), tube type (corresponding to tube colors: blue, pink and white) and repetition block (1, 2 or 3).

<b>Model Information</b>		
Dependent Variable		Response Time
Probability Distribution		Poisson
Link Function		Identity
Subject Effect	1	Subject
Within-Subject Effect	1	Human Hand/Device
	2	Color of Tube
	3	Repetition
Working Correlation Matrix Structure		Exchangeable

**Table 6: GEE Model Response Time**

The results of the analysis are given in Table 7.

<b>Tests of Model Effects</b>			
Source	Type III		
	Wald Chi-Square	df	Sig.
(Intercept)	39.324	1	.000
Human Hand/Device	.210	1	.647
Tube Type	21.684	2	.000
Repetition	45.597	2	.000
Human Hand/Device * Tube Type	27.756	2	.000
Human Hand/Device * Repetition	11.999	2	.002
Tube Type * Repetition	38.308	4	.000

**Table 7: Test of Model Effects: Response Time**

The mode of operation (human hand versus device) was not shown to be significant (Wald  $\chi^2(1, 53) = 0.210$ ,  $p = 0.647$ ). Thus, the null hypothesis could not be rejected, although it could not be accepted either. Therefore, a test of equivalency between the two conditions was made using a TOST test (Section 4.2.2).

The only main effects that were significant were tube type and repetition block (Wald  $\chi^2(2, 53) = 21.684$ ,  $p < 0.0005$  and Wald  $\chi^2(2, 53) = 45.597$ ,  $p < 0.0005$  respectively). Although all interaction effects were significant, only interaction effects for which both the main effects and the interaction effects are significant should be included in the final model. Thus, only the tube type \* repetition interaction were included in the final model (Table 8). A separate model checking for order effects concluded that there was no significance regarding response time, so the results were omitted.

### Tests of Model Effects

Source	Type III Wald Chi- Square	df	Sig.
(Intercept)	39.168	1	.000
Tube Type	21.874	2	.000
Repetition	36.614	2	.000
Tube Type * Repetition	37.337	4	.000

**Table 8: Response Time: Final Model**

Figure 22 through 23 show the estimated means for the responses for repetition block and tube type, as well as their interaction. Error bars indicate standard error.

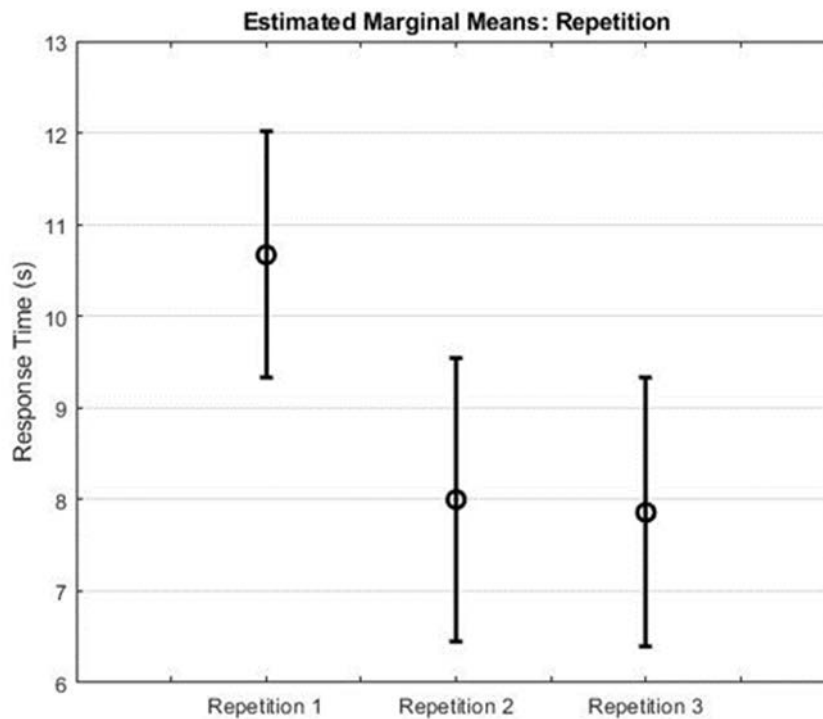

**Figure 22: Response Time: Estimated Marginal Means: Repetition**

Figure 22 suggested that repetition blocks 2 and 3 are more similar to each other than to block 1. Pairwise comparisons were made, adjusting for multiple comparisons using the least significant difference adjustment in SPSS, to further understand the effects. Differences were found to be significant between repetition blocks 2 and 1 ( $t(53) = 3.33, p = 0.001$ ) and blocks 3 and 1 ( $t(53) = 4.40, p < 0.0005$ ) but not blocks 2 and 3. As with error in volume extruded, this suggests that subjects were still learning the task during block 1 and may have reached steady state performance by block 2. Depending on the results on the interaction effects involving repetition, further analysis may only focus on blocks 2 and 3.

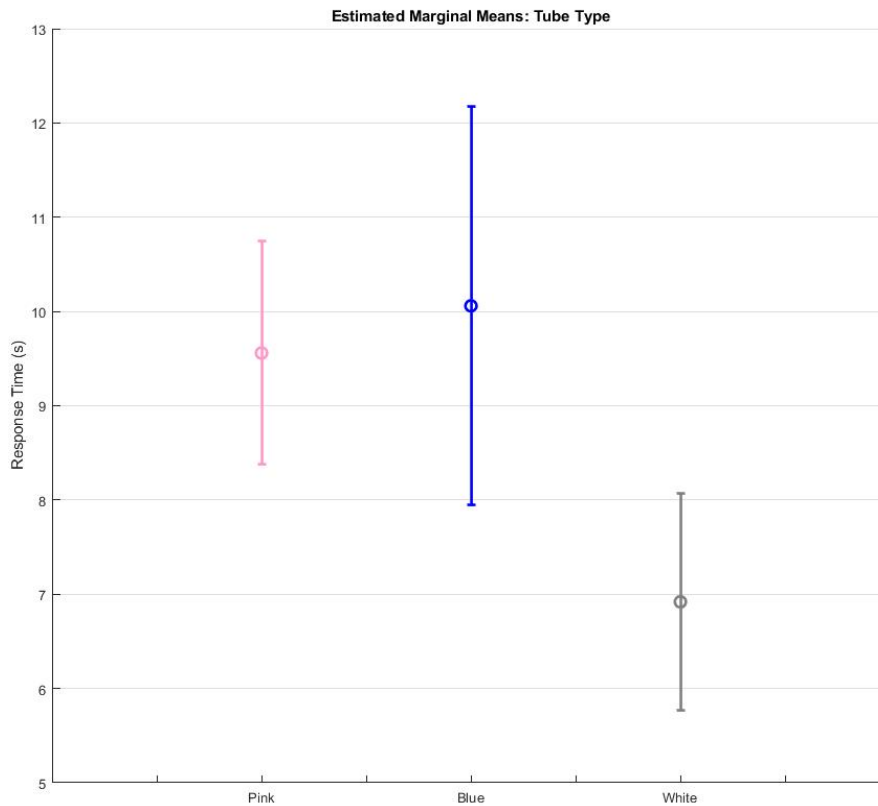

**Figure 23: Response Time: Estimated Marginal Means: Tube Type**

Figure 23 suggested that the material in the white tube (gel like paste) resulted in a rapid response rate compared to the other two tube types (blue = custard, pink = meringue). Pairwise comparisons were made to further understand the effect, again adjusting for multiple comparisons using the least significant difference adjustment in SPSS. Differences were found to be significant between the white (gel) and pink (meringue) tubes ( $t(53) = 2.29, p = 0.022$ ) and the white (gel) and blue (custard) tubes ( $t(53) = 4.68, p < 0.0005$ ) but not the pink (meringue) and blue (custard) tubes ( $t(53) = 0.42, p=0.434$ ). Interestingly, the rapid response rate correlated with an increase in the volume error of what was extruded.

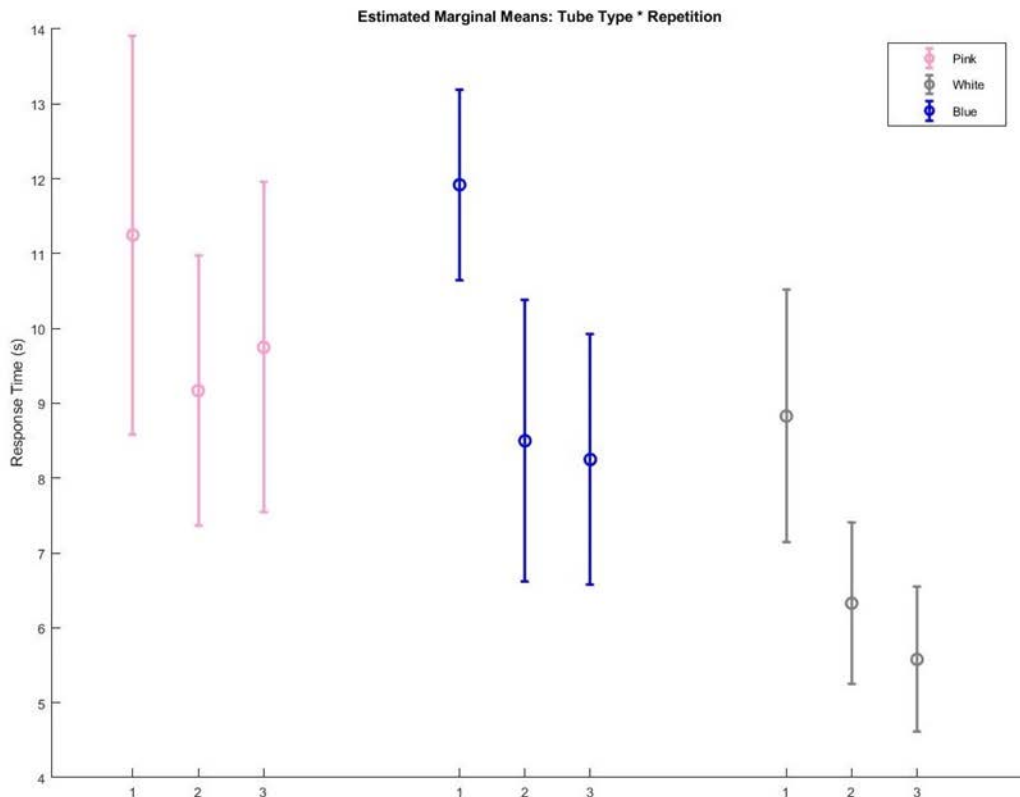

**Figure 24: Response Time: Estimated Marginal Means: Tube Type \* Repetition**

Figure 24 shows the estimated marginal means for response time as a function of tube type and repetition block. The interaction term considers the effect after the two main effects (tube type and repetition) are removed. Figure 24 suggests that there again may be an interaction effect in the difference of the first repetition block from blocks two and three. It appears that the blue tube, this time, as more of an improvement with repetition than the other two tube types. This again seems to be consistent with the pairwise comparisons between block repetitions within each tube type. Although it would be desirable to only analyze repetition blocks 2 and 3 in further analysis, this was not performed due to the significant drop in statistical power in doing so.



## 4.2.2 Analysis of Equivalence

The mode of operation (human hand versus device) was not shown to be significant (Wald  $\chi^2(1, 53) = 0.210, p = 0.647$ ) in the GEE analysis. However, based on the form of the hypothesis, equivalency between the two conditions could not be concluded. Therefore, a test of equivalency between the two conditions was made using a two-one sided t-test (TOST) equivalency test, executed with SAS. The equivalency bound for response time was set between 80% and 125% in keeping with common standards for clinical significance (Castelloe & Watts, 2015).  $H_0$  was defined to be a negative difference effect more negative than the lower equivalence boundary.  $H_1$  was defined as any positive difference in effect above the upper equivalence boundary (Figure 25).

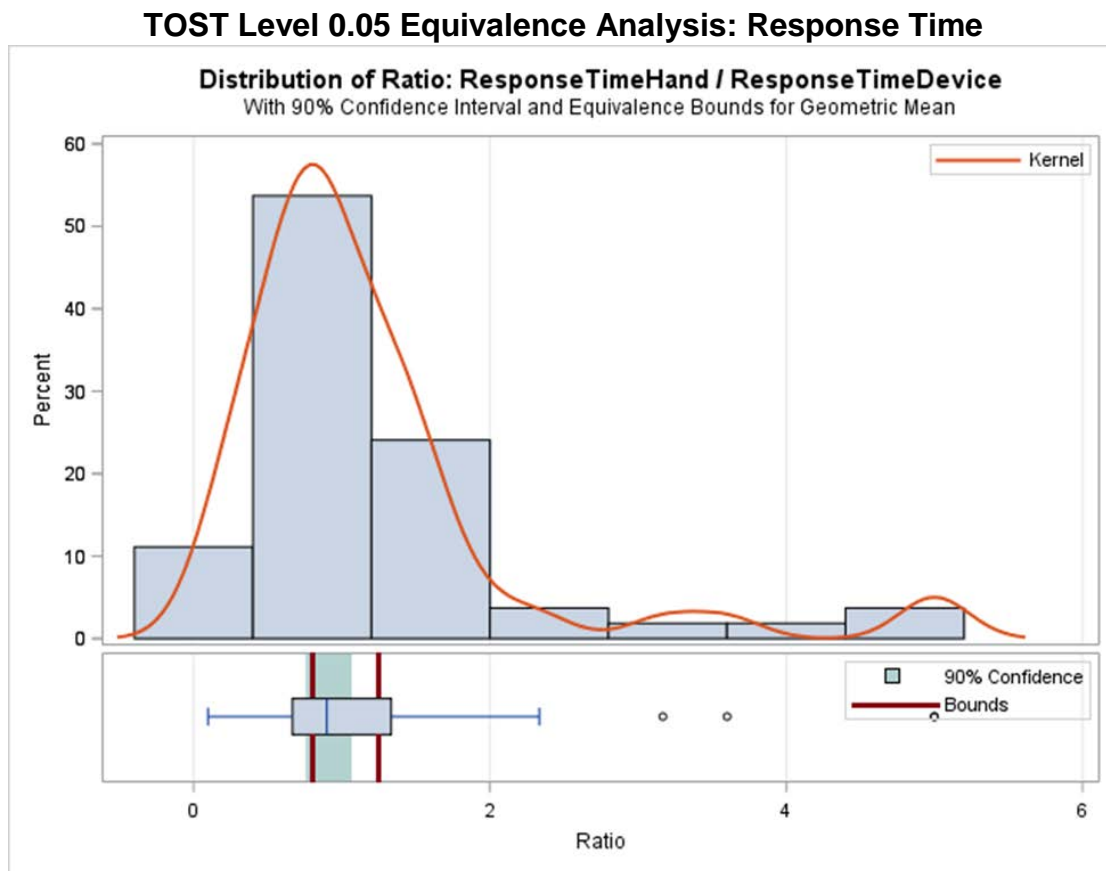

Figure 25: Distribution Ratio Response Time

The results of the TOST analysis showed that the response time could not be considered equivalent because  $H_1$  did not reach significance (Table 9). Therefore, the response times between the two conditions could not be stated as different or equivalent.

<b>Geometric Mean</b>	<b>Lower Bound</b>		<b>90% CL Mean</b>			<b>Upper Bound</b>	<b>Assessment</b>
0.8986	0.8	>	0.7566	1.0671	<	1.25	Not equivalent

<b>Test</b>	<b>Null</b>	<b>DF</b>	<b>t Value</b>	<b>P-Value</b>
<b>Upper</b>	0.8	53	1.13	0.1315
<b>Lower</b>	1.25	53	-3.21	0.0011
<b>Overall</b>				0.1315

**Table 9: TOST Equivalency: Response Time**

## 5 Discussion

The aim of this thesis was to develop an antagonistic position-impedance controller for a human hand that could be used in activities of daily living in two handed tasks where the prosthetic hand stabilizes or applies simple forces to a compliant object for controlled manipulation. A two fingered prosthetic simulator was used to test the developed controller with two actuators in an antagonistic pair. The control algorithm used surface EMG signals from the lower arm of the subject to control the grasp aperture using a nonlinear mapping from the EMG signal to the aperture command. It also used an autonomous force controller to autonomously modify the stiffness of the interaction between the user and the material being manipulated. The value of the stiffness to be used was determined automatically a priori to testing using two small, quick palpations to record the stiffness of the interaction with the given object.

The aim of the experimental study was to test whether the prosthetic simulator with antagonistic position-impedance control would be able to assist in the performance of a controlled squeezing task in a manner comparable to the human hand. Healthy subjects performed the bimanual squeezing task on tubes containing a variety of paste samples both normally (using the subject's own hands) and using the prosthetic system to replace the squeezing hand. Subjects were asked to squeeze a tube of compliant material with their left hand/prosthetic device a defined amount onto a popsicle stick held in their right hand. When using the prosthetic device, the aperture was controlled via EMG signals from the left forearm of the subject, while the device automatically regulated the overall stiffness. Performance metrics included volume extrusion error and response time. Volume extrusion error refers to the difference between the target volume ( $1.1\text{cm}^3$ ) and

the volume extruded by the user. The response time was defined as the time for the user to complete the task.

Statistical analysis of performance metrics using GEE and TOST analysis revealed that the prosthetic controller and human hand exhibit similar characteristics. The mode of operation by which subjects performed the bimanual ADL task (Human Hand or Device) was not found to have a statically significant difference in either the Volume Extrusion Error or in Response time (Table 2 and Table 7). Differences that did exist in Volume Extrusion Error and Response Time correlated much more strongly to the color of tube used during a trial and the attempt number. Testing the device and human hand performance for equivalence revealed that the Volume Extrusion Error was equivalent regardless of which method of control was used (Table 5). However a similar claim cannot be made for Response Time (Table 9). Response times for the Human Hand and Device, although not significantly different (Wald  $\chi^2(1, 53) = 0.210, p = 0.647$ ) do not meet the necessary criteria to be considered equivalent.

Since half the trials started with the human hand and half started with the device, we were able to observe any potential ordering effect. The results showed that the trial order (Human Hand first versus Device first) had a significant effect on the Volume Extrusion Error (Figure 20). The Volume Extrusion Error was less when subjects performed the task using the Human Hand first. It is possible that subjects were able to gain insight into the tactile properties of the object and unite that information with the extrusion properties of each tube. This knowledge may have given the user better insight for how to interact with each tube when they moved to the next block of trials. Future

studies may seek to mitigate this effect by using tubes of a uniform color, where subjects could not associate the color of the tube with the paste in the tube.

Differences that did exist in Volume Extrusion Error and Response Time correlated much more strongly to the color of tube used during a trial and the repetition block. The Volume Extrusion Error when using the white tubes (gel-like paste) was significantly greater than when using the pink (meringue) or blue (custard) tubes (Figure 17). However, the response time was significantly less (Figure 23). This cannot be attributed to an order effect in the study as presentation of the tube types were counterbalanced across repetition block and subject. In addition, the stiffness of the pastes inside the white tubes was similar to that inside the pink tubes (Figure 19). This suggests that the effect cannot be attributed to differences in stiffness. A potential explanation is that the pastes in the white tubes were qualitatively felt to be a less viscous paste than the others: although it may occupy a similar apparent stiffness range to the substance in the pink tube, the manner in which it extrudes was different. The pastes in the blue tubes, although higher and more variable in their apparent stiffness, were able to be manipulated in a manner similar to the pink tube.

The more accurate extrusion of the pastes in the pink and blue tubes over their range of stiffness values suggests that both the human system and the device can adapt to pastes of a variety of stiffness values that one would expect to find in ADLs. However the poorer ability of both systems to control the extrusion of pastes from the white tubes, even though the stiffness values are similar to the pastes in the pink tubes, suggests that the apparent stiffness is only one variable that contributes to how a compliant tube extrudes its material. It is interesting to note, though, that both the device controller and

the human system have similar performance decreases. In addition, both methods have a similar decrease in response time with the pastes in the white tubes. This suggests that in some way the antagonistic position-impedance controller is mimicking the behavior of the human hand. This is also supported in that there are no initial differences in the performance metrics between the developed controller and human hand, suggesting that no learning was needed to match human hand performance. Although a better model of the contact mechanics and measurement of the impedance of the tubes could improve performance for the prosthetic controller, there is an argument against this: for a one hand amputee, the behavior of the prosthetic and the healthy hand would have similar performance expectations. This would help to keep the cognitive load low because of the consistency between the two hands and the mimicking of natural behavior.

In addition to the control method, the strategy of using small palpations before a trial to measure the stiffness of the tube before squeezing appeared to work well for the prosthetic controller. This could easily be incorporated into a task for use of a prosthetic during actual everyday use. This has an advantage as it avoids the need to develop computationally expensive models of contact. This can allow for processing power to be allocated to other tasks, with the aim of improving dexterous manipulation. Further research is needed as to how small the palpations can be and whether the brief initial contact during the actual task itself would be sufficient to obtain the stiffness measurement. Another consideration is the use of a look up table for known objects (such as the morning's use of the toothpaste tube). This would be consistent with what is known about grasping and manipulation in that control is an anticipatory process (Flanagan, Merritt, & Johansson, 2009).

## 5.1 Unexpected Findings

The first attempt for each tube was found to be better than the second and third attempts for both the human hand and the prosthetic controller (Figure 16). The first attempts were also slower than the second and third attempts (Figure 22). This could potentially be explained by subjects being more excited and motivated about the study in the first block of trials than later trials, resulting in them being more careful in performing the task. In trials involving the prosthetic controller using EMG signals from the forearm, reduced strength of muscle contraction may have also occurred during the later trials if subjects tired or forgot the contraction levels used during previous trials. This could have led to more inaccuracy in the volume extruded. However, the human hand trials also showed a similar reduction in volume extrusion accuracy. Overconfidence, fatigue, or decreased focus may also have contributed to the decrease in accuracy and the increase in speed of task as the trials progressed.

## 5.2 Limits

One of the limitations in the task itself were the pastes that were fabricated. These were intended to be of different stiffness and with smaller variability in the stiffness. As it turned out, the stiffness of the pastes in the pink and white tubes were similar. However, this produced some of the more interesting results of the study as performance differences appeared with the two types of pastes despite their similarity in stiffness. This suggests that further variation in paste consistency along dimensions other than stiffness are needed to verify performance during everyday ADLs with different commercial products. In addition, the use of containers with different material properties (although all squeezable) is needed to assess potential performance with commercial products.

The variability in the stiffness within each tube type occurred as the pastes recipes yielded inconsistent properties from sample to sample as the paste aged and settled. Whether a paste was stirred or not also had an effect. The apparent stiffness of the tube also likely depends on the fill volume of the tube, the pressure profile applied, and age of the tube. Care was taken to ensure that the tube nozzle was not occluded by dried paste, the tubes had a similar fill volume and the tubes were squeezed to remove any air. Regardless of the measures taken to provide similar circumstances, attempts to create similar tubes across the subjects was difficult. As a result, the tubes of one type used by one subject may have felt different than another in terms of apparent stiffness regardless of the formulas and methods used to create them. However, with respect to real world applications, more variability (such as due to dried paste, no stirring of the paste, air in the tubes, etc.) may have been desirable to assess real world performance. In future studies, assessment of the device using commercially available pastes could help validate device effectiveness for use in everyday scenarios.

Another potential limitation of the study appeared in the differences across repetition blocks. The first repetition block appeared to result in more accurate but slower performance. It appears that as subjects got familiar with the task (repetitions 2 and 3), they may have changed their objectives (i.e., speed became more important than accuracy). This may have been alleviated if a more precise question (e.g., you should be as precise as possible taking as much time as you wish) was posed and the subject was reminded of the given objective on every trial. The exploration of the use of different questions may also have been interesting to determine how performance varied with different objectives that may actually appear in real world behavior.



Finally, the study did not involve both hands, amputees were not involved and only one task involving precise control of compliant objects was explored. Two hands may have created a complexity in the task that decreased performance with the prosthetic device (with a human hand) compared to two human hands. However, it could also have introduced an experimental artifact in that some subjects may have relied on compensation strategies with the healthy hand when using the prosthetic device. Only one task involving compliant objects was performed and only with 3 pastes with limited variability. To more fully understand expected performance in ADLs involving compliant objects, more tasks and more variety of objects would need to be assessed. Finally, as the target population is amputees, assessment is needed with this population before deployment in the real world. The current test of the system was meant as a first initial study to ascertain the potential of the antagonistic position-impedance controller to achieve similar functionality to the human hand. In tests involving real amputees, a few alterations must be performed to adapt the system to the target population due to physical changes that occur as a result of amputation. A new electrically neutral location, away from the measured muscles, must be selected for the EMG reference electrode since the bony portion of the wrist is no longer present. Additional filtering may need to be implemented to isolate the residual muscle signals from the new surrounding muscles post amputation. Future studies with amputees, using two hands and with a larger variety of tasks and objects, are needed to evaluate whether the system is effective to use, with low cognitive load, for the intended population.

### 5.3 Practical Implications

The results of the study suggest that the antagonistic position-impedance controller performs comparably to the human hand for the bimanual task examined. The device adapted to the various compliant tubes as well as the human hand. Use of this type of control could allow single handed prosthetic users to accomplish ADL involving compliant objects with a low cognitive load. Improving prosthetic performance across a range of ADL could increase rate of acceptance and allow users greater levels of independence.

The apparent stiffness of a paste is likely complex in its calculation from the knowledge of its basic ingredients and environmental factors, depending on a variety of factors including temperature, loading profile, and pressure within the tube. Experimental estimation of the apparent stiffness a priori (through two small palpations) seemed sufficient for the device controller to provide similar performance to the human hand. This suggests that experimental measurements of object's basic mechanical properties may be sufficient for effective control during simple manipulation. Similarities in performance behavior suggest that the human hand may also use an experimental measurement of stiffness in control; however, obviously, users do not usually perform small palpations before manipulating an object. In the human system, it is possible that this information is obtained through the very initial contact with an object as skin mechanoreceptors respond to the deformation (Westling & Johansson, 1987). A study of compliant object grasping also identified slower loading phases in the face of uncertain properties, and suggested the body may implement a probing strategy to learn about the contact structure (Wingens,

Eonta, Soechting, & Flanders, 2009). Future work will explore whether the initial measurement upon contact can be effectively used immediately for the squeezing task.

Finally, this study lends support to a prior study (Arenas, 2015) suggesting that Proportional Nonlinear Control is an intuitive method for commanding signals in a hand prosthesis. This method of EMG control allowed subjects to learn to operate the prosthetic quickly within a single training session lasting between 10 to 30 minutes depending on the subject. Participants learned to achieve the desired aperture on demand with minimal training.

## 5.4 Perspective and Future Considerations

Human motor control of the hand uses co-contraction as a strategy to control grip aperture independent of force of contact (Hogan, 1984a). Co-contraction is useful for modulating impedance to task requirements. There are a variety of ways that antagonistic control could be implemented in a prosthetic. A prior study attempted to allow users to voluntarily modulate the stiffness of an artificial joint using the co-contraction of a pair of agonist and antagonist muscles (Sensinger & Weir, 2007). This in some ways mimics the strategy of human motor control, but the control signal needed to be consciously generated by a co-contraction of the muscles while also trying to control movement of the device simultaneously based on the difference in muscle activation of the opposing muscles. In natural co-contraction, levels of muscle activation are mediated by spinal circuit based motor command signals specific to the task. Although EMG provides insight into user intent, the influence of the autonomous spinal circuits may not be reflected in the device's command signal when the arm is removed from direct interaction with the task. As a consequence, this prior study found that subjects did not naturally co-contrast

their muscles to match their environment and task. In fact, users were often unwilling to change the stiffness unless the tuning was very poor for the task.

In this work, we considered an alternative in which the human user would only have to control grip aperture, while the controller itself would automatically handle the impedance of contact. For the given task studied, similarities in performance behavior for human motor control and the proposed control algorithm suggest that a more effective strategy is to keep the less intuitive part of the algorithm under automated control. The human system is able to overcome slow reaction times by using anticipatory adjustment of impedance. This adjustment is done with minimal conscious involvement through action of autonomous spinal circuits. Considering the limitations in control and feedback due to severing of the afferent and efferent signals after amputation, the automation of impedance regulation allows for improved manipulation without introducing excessive cognitive load to the user.

When interacting with a new object, the human system creates an assumption of the properties of the grasped object, which is updated during the interaction. Tactile feedback is too slow to immediately affect the performance, but is used to adjust the grasp and update future interaction models. In this study, the control scheme was designed to operate in a similar manner by scaling its impedance based on an estimation of object stiffness. Common approaches to prosthetic control typically do not scale interaction parameters to the object being grasped. Although using brief palpations for stiffness interaction is not common during manipulation, it has potential to be beneficial in tasks that require a more gentle, yet still stable mechanical coupling by allowing the device to identify the proper interaction forces when interacting with the object. In a real world

environment, this brief palpation sequence could be initiated through a muscle contraction pattern that would cause the prosthetic to test the object stiffness and adjust device parameters to the object prior to interaction.

Future studies may explore the optimal stiffness levels for a variety of tasks depending on the objective and on the object being grasped. Studying the object properties revealed during grasping in response to different force or displacement profiles could lead to the creation of several preset stiffness profiles stored within system memory that allow the prosthetic device to adapt to objects with vastly different properties. After identifying and classifying the object's properties, the behavior of the prosthetic could be modified further to match the task requirements. Task requirements might be identifiable by looking at characteristic patterns of user EMG activation in various ADL. Perhaps certain patterns typically point towards either a stabilization or manipulation task. If object properties and task type could be known to the device, an appropriate impedance level could be selected. This type of autonomous stiffness control would allow for the prosthetic to be useful in a variety of activities of daily living with objects of many different properties, offering the user advanced control without intensive control training.

Prior prosthetic concepts have used compliant manipulators to help avoid undesired contact forces during interaction (Dollar & Howe, 2007). Use of a purely compliant grasp certainly helps avoid application of excessive force, however it loses ability to accurately specify position. Prosthetics also benefit from the ability to increase device stiffness. Higher stiffness allows for better positional control, which is useful when task requirements demand stable grasping or an ability to control object deformation. The

ability to modulate stiffness values is preferable to an always compliant grasp for its ability to adapt to a range of requirements.

The developed control scheme operates in a manner similar to the human system. It allowed for a priori estimation of object properties and automatically scaled the device impedance through the action of opposing actuators while users controlled the grasp aperture. A position or velocity controlled device would have been more prone to creating undesired contact forces when interacting with the compliant tubes. Force controlled prosthetics would have greater difficulty controlling the extrusions given the deformable surface of the tube. Through the developed system, users were able to control position with force levels appropriate to the object in a manner not possible using common control methods. Further studies may explore extending the concept to a multi-jointed hand to allow additional grasp orientations that would help amputees perform a wider range of ADL and increase independence.

## 6 Conclusion

A prosthetic interface was created that was able to autonomously modulate impedance based on an initial palpation of a compliant tube containing a paste to gauge its apparent stiffness. The system included an algorithm for detection of the apparent stiffness of an object, a proportional nonlinear EMG control algorithm for interpreting user commanded position, and an agonist-antagonist position-impedance controller that modulated device impedance during interaction. Performance of the control interface was compared to performance of a human hand for the extrusion of a paste from a tube onto a popsicle stick held by the other hand. Performance metrics collected during the trials were the paste volume extrusion error and response time to perform the task.

Statistical analysis using GEE and TOST suggested that the prosthetic controller and human hand performed similarly, with differences in performance being more strongly correlated to tube type and repetition block. The volume extrusion error was shown to be equivalent regardless of control method used. Response times using each method, although not equivalent were not significantly different (Wald  $\chi^2(1, 53) = 0.210$ ,  $p = 0.647$ ). Accurate extrusion of the pastes from the blue tubes (the consistency of custard) and pink tubes (the consistency of a meringue) over the range of stiffness values suggests that both the human hand and device are able to adapt to a range of stiffness values common to ADL. Performance decreases by the human hand when using the white tube were also mirrored by the device. Comparable performance across all tubes suggests that the developed control method potentially operates in a manner similar to the human hand.

Results of the study suggest that the developed controller allows users to perform a bimanual squeezing task at a level comparable to the human hand with minimal training. They also suggest that the simple experimental estimation of stiffness properties may be sufficient for effective control during simple manipulation. Incorporation of these concepts into prosthetic control could lead to prosthetics that allow users to accomplish a wide range of ADLs involving compliant objects with a low cognitive load.



## 7 References

- Arenas, J. A. (2015). *Evaluation of a Novel Myoelectric Training Device*. (Unpublished Master's Thesis). Virginia Commonwealth University, Richmond, Virginia
- Biddiss, E., Beaton, D., & Chau, T. (2007). Consumer Design Priorities for Upper Limb Prosthetics. *Disability and Rehabilitation: Assistive Technology*, 2(6), 346–357.  
<https://doi.org/10.1080/17483100701714733>
- De Luca, C. J. (2002). *Surface Electromyography: Detection and Recording*. DelSys Incorporated.
- Dollar, A. M., & Howe, R. D. (2007). The SDM Hand as a Prosthetic Terminal Device : A Feasibility Study. *2007 IEEE 10<sup>th</sup> International Conference on Rehabilitation Robotics*, Noordwijk, 2007, pp. 978-983.
- Duruoz, M. (2014). *Hand Function: A Practical Guide to Assessment*. New York: Springer. <https://doi.org/10.1007/978-1-4614-9449-2>
- Engstrom, B. (1999). *Therapy for Amputees*. (B. Engstrom & C. Van de Ven, Eds.) (Third Edit). Churchill Livingstone.
- Flanagan, J. R., Merritt, K., & Johansson, R. S. (2009). Predictive Mechanisms and Object Representations Used in Object Manipulation. In. D. Nowak & J. Hermsdörfer (Eds.), *Sensorimotor Control of Grasping: Physiology and Pathophysiology*, (pp.161-177). Cambridge: Cambridge University Press  
<https://doi.org/10.1017/CBO9780511581267.013>
- Hanley, J. A., Negassa, A., Edwardes, M. D. d. B., & Forrester, J. E. (2003). Statistical

Analysis of Correlated Data Using Generalized Estimating Equations: An Orientation. *American Journal of Epidemiology*, 157(4), 364–375.

<https://doi.org/10.1093/aje/kwf215>

Hatzfeld, C., & Kern, T. A. (2014). *Engineering Haptic Devices: A Beginner's Guide* (2nd ed.). London: Springer-Verlag.

Hogan, N. (1984a). Adaptive Control of Mechanical Impedance by Coactivation of Antagonist Muscles. *IEEE Transactions on Automatic Control*, 29(8), 681–690.

<https://doi.org/10.1109/TAC.1984.1103644>

Hogan, N. (1984b). Impedance Control of Industrial Robots. *Robotics and Computer Integrated Manufacturing*, 1(1), 97–113. [https://doi.org/10.1016/0736-](https://doi.org/10.1016/0736-5845(84)90084-X)

[5845\(84\)90084-X](https://doi.org/10.1016/0736-5845(84)90084-X)

Hogan, N. (1985). Impedance Control: An Approach to Manipulation. *American Control Conference, 1984*, 107(1), 304–313. <https://doi.org/10.1115/1.3140702>

Höppner, H., McIntyre, J., & Van Der Smagt, P. (2013). Task dependency of grip stiffness - A study of human grip force and grip stiffness dependency during two different tasks with same grip forces. *PLOS ONE*, 8(12).

<https://doi.org/10.1371/journal.pone.0080889>

Howe, R. D. (1994). Tactile Sensing and Control of Robotic Manipulation. *Journal of Advanced Robotics*, 8(3), 245–261. <https://doi.org/10.1163/156855394X00356>

Mascha, E. J., & Sessler, D. I. (2011). Equivalence and noninferiority testing in regression models and repeated-measures designs. *Anesthesia and Analgesia*,

112(3), 678–687. <https://doi.org/10.1213/ANE.0b013e318206f872>

Plettenburg, D. H. (2006). *Upper Extremity Prosthetics: Current Status & Evaluation*. Delft: VSSD.

Raichle, K. A., Hanley, M. A., Molton, I., Kadel, N. J., Campbell, K., Phelps, E., ... Smith, D. G. (2008). Prosthesis Use in Persons with Lower- and Upper-Limb Amputation. *Journal of Rehabilitation Research and Development*, 45(7), 961–972. <https://doi.org/10.1682/JRRD.2007.09.0151> LK

Sacchetti, R., Davalli, A., Ciancio, A. L., Cutti, A. G., Cordella, F., Guglielmelli, E., & Zollo, L. (2016). Literature Review on Needs of Upper Limb Prosthesis Users. *Frontiers in Neuroscience*, 10(May), 1–14. <https://doi.org/10.3389/fnins.2016.00209>

Sensinger, J. W., & Weir, R. F. ff. (2007). User-Modulated Impedance Control of a Prosthesis in Unconstrained, Perturbed Motion: Evaluation of Paradigm Performance. *IEEE Transactions on Biomedical Engineering, TBME-00028*(3), 1043–1055.

Smurr, L. M., Gulick, K., & Yancosek, K. (2008). Managing the Upper Extremity Amputee: A Protocol for Success. *Journal of Hand Therapy*, 21(2), 160–176. <https://doi.org/10.1197/j.jht.2007.09.006>

Spires, M., Kelly, B., & Davis, A. (2014). *Prosthetic Restoration and Rehabilitation*. New York: Demos Medical Publishing, LLC.

Tennent, D. J., Wenke, J. C., Rivera, J. C., & Krueger, C. A. (2014). Characterisation and outcomes of upper extremity amputations. *Injury*, 45(6), 965–969.

<https://doi.org/10.1016/j.injury.2014.02.009>

Washam, V. (1973). *The One-Hander's Book*. New York: The John Day Company.

Weir, R. F. (2003). Standard Handbook of Biomedical Engineering and Design. In M. Kutz (Ed.), *Standard Handbook of Biomedical Engineering and Design*. New York: McGraw-Hill.

Westling, G., & Johansson, R. S. (1987). Responses in glabrous skin mechanoreceptors during precision grip in humans. *Experimental Brain Research*, 66(1), 128–140. <https://doi.org/10.1007/BF00236209>

Wing, A. M., Haggard, P., & Flanagan, J. R. (1996). *Hand and Brain: The Neurophysiology and Psychology of Hand Movements*. San Diego: Academic Press, Inc.

Wing, S. A., Eonta, S. E., Soechting, J. F., & Flanders, M. (2009). Effects of Object Compliance on Three-Digit Grasping. *Journal of Neurophysiology*, 101(5), 2447–2458. <https://doi.org/10.1152/jn.91021.2008>

## Appendix A: System Code

### ***Arduino Code: AutoPositionImpedanceController\_11\_13***

```
#include <PID_v1.h> //PID Library
#include <Servo.h> //Servo Library

//Communication Rate and Timing

const int rateSerial = 9600;
long timeTraj= 100;// how often to read EMG & update trajectory profile in (ms)
const int pidSampleTime = 10; //pid Sample time (ms)
const int waitForIt = 100; //delay before input command
long neededInterval=100; //used to schedule trajectory command timing
long lastTime; //duration between trajectory updates
long lastTime2; //duration between servo updates
long startTime; //keeps track of runtime duration
long sinusoidTime; //duration between EMG read commands

//Digital Pin Assignments

const int EXT_SERVO = 9; //specify servo digital pin
const int FLEX_SERVO = 10; //specify servo digital pin
const int rest = 30; //specify red LED
const int select = 32;//specify blue LED
const int active = 34;//specify green LED
const int RESET_BUTTON= 50;

//Analog Pin Assignments
const int Load_Cell = 1; //specify Load cell pin;
const int EMG_Signal = 2; //specify EMG_Input signal;
const int ROT_DIF = 0; //specify differentiated rotary pot pin;
const int ROT_POT = 5; //specify rotary potentiometer pin
const int pot_flex = 9; //specify potentiometer pin
const int pot_ext = 8; //specify potentiometer pin

//Servos
Servo extensor;
Servo flexor;
const int MIN_ExtPulse = 1025; //1025 and 1700 are safe boundaries without servo humming.
const int MAX_ExtPulse = 1700; //once attached extensor.write(0) corresponds to 1025ms
//extensor.write(180) corresponds to 1700ms
```

```

const int MIN_FlexPulse = 1025; //1025 and 2100 are safe boundaries without servo humming.
const int MAX_FlexPulse = 2100; //once attached flexor.write(0) corresponds to 1025microseconds
//flexor.write(180) corresponds to 2100ms
const int MIN_ExtAngle= 40; //Limit Ext Position
const int MID_ExtAngle= 40; //Reference for Ext Pos
const int MAX_ExtAngle= 100; //Upper limit to Ext Range
const int MIN_Flexor=80; //Select the Desired Minimum Flexor Angle to Start
const int MAX_Flexor=140; //Select the Desired Maximum Flexor Angle

/*Force PID Kp=183.75*z*z-105.66*z+18.607 , Ki=25, Kd=.085*/
double Setpoint, Input, Output;
double z=.3; //Stiffness Value
double kp=183.75*z*z-105.66*z+18.607; //modify Kp according to z
const double ki=25;//10; //ki=.0956;
const double kd=.085; //.0055; //kd=.03585;

PID ForcePID(&Input, &Output, &Setpoint,kp,ki,kd,P_ON_M,REVERSE);

//Trajectory Array
const int arraySize = 15;
int trajArray[arraySize] = {0,0,0,0,0,0,0,0,0,0,0,0,0,0,0};
//0,1,2,3,4,5,6,7,8,9,10,11,12,13,14

//useful globals
int flexorPos, extPos; //Current Flexor and Extensor Positions
int arrayLocation=0;
int DeviceMode=1;
int accumulation=0; //used to collect switching signal
int thresh=60; //how many negative signals required for a switch

//Setpoint Modifiers
bool Contact=false; //signify when to reset Fo
double Deformation=0; //track total position
double Fo=0; //keep track of initial contact force
int sendZnow=0;
int commandinput;

```

```

void setup()
{
  //Start serial
  Serial.begin(rateSerial);

  //Attatch the servos
  extensor.attach(EXT_SERVO,MIN_ExtPulse,MAX_ExtPulse);
  flexor.attach(FLEX_SERVO,MIN_FlexPulse,MAX_FlexPulse);

  //setupDisrupt Button
  pinMode(RESET_BUTTON,INPUT); //Read for the system reset signal

  //Initialize Servo Position Values
  zeroServos();
  delay(1000);
  resetMode();
  extensor.write(extPos); //move ext
  flexor.write(flexorPos); //move flex
  delay(3000);

  //Initialize Force Controller variables
  ForcePID.SetSampleTime(pidSampleTime); //initialize PID Timing compute at pidSampleTime
  ForcePID.SetOutputLimits(MIN_ExtAngle,MAX_ExtAngle); // clamp from extensor 40 to 100
  Input=valLoadCell(); //initialize Input value to start value
  Setpoint=Input;

  Contact=false;

  //Start the timing
  startTime=millis();
  lastTime=startTime;
  lastTime2=lastTime;
  sinusoidTime=lastTime2;
  delay(1000);
  DeviceMode=1;
}

```

```

void loop()
{
  /*Read EMG Input*/
  if(millis()-sinusoidTime >= waitForIt)
  {
    if(DeviceMode==1) //if system reset ignore EMG Input //red LED
    //commandinput=112;//from 60
    {
      systemStateIndicator(DeviceMode);
      resetMode(); //set Flex and Ext to Defaults
      commandinput=flexorPos; //don't update trajectory

      if(inputEmg()==-44) //if the swap mode signal is sent...swap the mode
      {

        accumulation++;
        if(accumulation>=thresh)
        {
          DeviceMode=2; //set Device to autoselection mode
          accumulation=0;
        }
      }

    }

    else if(DeviceMode==2)
    {
      systemStateIndicator(DeviceMode);
      autoSelect(); //run short Zn test and Select Zc
      commandinput=flexorPos;
      sendZnow=1;
    }
    else if(DeviceMode==3)
    {
      systemStateIndicator(DeviceMode);
      int potentialcommand=inputEmg();
      if(potentialcommand>0)
      {
        commandinput=potentialcommand;
      }
    }
  }
}

```



```

if(digitalRead(RESET_BUTTON)==HIGH) //if the swap mode signal is sent...swap the mode
{
  accumulation++;
  if(accumulation>=thresh)
  {
    DeviceMode=1; //set Device to autoselection mode
    zeroServos();
    delay(100);
    accumulation=0;
  }
  resetMode(); //set Flex and Ext to Defaults
}
}

sinusoidTime=millis();
}

/*Trajectory Timing*/
if(millis() - lastTime > timeTraj) //every timeTraj ms execute this code
{
  if(DeviceMode==3)
  {
    movePlan(commandinput); //Read EMG, Determine movement, Plan Trajectory

    //if(trajArray[0]>=0) //if array will command closing
    if(trajArray[0]>0) //if a closing command is issued
    {
      if(ForcePID.GetMode()==0)//This might just work
      {
        Output=extPos;// This might just work
      }
      ForcePID.SetMode(AUTOMATIC); //turn on when closing
      Contact=false; // rids excess setpoint spiking during continuous operation
    }
    else
    {
      ForcePID.SetMode(MANUAL); //ignore and turn off when opening
      Output=extPos; //Eliminates Bump
    }
  }
}

```

```

if(trajArray[0]!=0) //if there is a nonzero command to the trajectory...
    //wait until 600ms or change in timeTraj to make new trajectory
    {
        timeTraj=600;
    }

    arrayLocation=0; //move back to the start of the array
    lastTime=millis(); //record last time the function was called

}
}

/*Modify Servo Location Desire*/

if(millis() - lastTime2 > neededInterval) //modify the flexor position and setpoint
    //according to the timing needed for the trajectory
    {

        flexorPos = flexorPos + trajArray[arrayLocation]; //shift the desired flexor position
        flexorPos= constrain(flexorPos,MIN_Flexor,MAX_Flexor); //keep within safe bounds

        if(trajArray[arrayLocation]<0) //if opening the hand
        {
            if(valPotFlex()>0) //if in contact still... slowly move to the reset position
            {
                if((MID_ExtAngle-extPos)>0)
                {
                    extPos=extPos+4;
                }
                if((MID_ExtAngle-extPos)<0)
                {
                    extPos=extPos-4;

                    if(extPos<MID_ExtAngle)
                    {
                        extPos=MID_ExtAngle;
                    }
                }
            }
        }

        if(valPotFlex()==0) //contact broken.... return quickly to reset position

```

```

    {
        extPos=MID_ExtAngle;
    }
}

if(ForcePID.GetMode()==1)
{
    if(Contact==false) //if force is present and contact has not been noted
    {
        Fo=0; //reset contact force to zero until contact is known
        Deformation=0; //start tracking commanded position at contact

        if(valLoadCell()>0) //if contact is present, record the force
        {
            Fo=valLoadCell(); //set the current force as the contact force
            Contact=true; //contact has occurred
        }
    }
    if(Contact==true)
    {
        Deformation=trajArray[arrayLocation]+Deformation; //add to current total post contact
    }
    Setpoint = setpointMod(z,Deformation,Fo); //send contact force instead of constant val
}

if(trajArray[arrayLocation]==0) //if there is no more trajectory... begin another trajectory
{
    timeTraj=100;
}

trajArray[arrayLocation]=0; //ensure data is zeroed after use

if(arrayLocation<(arraySize-1))
{
    arrayLocation++; //shift cell only if possible
}
else if(arrayLocation==(arraySize-1))
{
    timeTraj=100; //if the last cell is being added... check the trajectory input again
}

lastTime2 = millis(); //set it up to wait another 30ms

```

```

}

Input=valLoadCell(); //Update the Input to the feedback value

if(ForcePID.GetMode()==0) //Make Setpoint Follow Input When OFF and Reset Contact
{
    Setpoint=Input;
    Contact=false;
}

//Compute the PID once per loop
ForcePID.Compute(); //calculate once per loop returns true when output is computed.
//Computes at frequency specified by SetSampleTime

if(ForcePID.GetMode()==1)
{
    if(Contact==true)
    {
        extPos=Output; //if in contact while pid is on. Update extPos to the PID output
    }
}

//SerialCommunication Output //For use exporting data to .csv file using processing
Serial.write('H');
sendBinary(valPotFlex());
//sendBinary(commandinput); //use this instead of another command to see the observed EMG
sendBinary(flexorPos);
sendBinary(extPos);

if(sendZnow==1) //if a new Z has been commanded...Output that data in place of Setpoint
{
    doublePrep(z);
    sendZnow=0;
}
Else //export Setpoint value in all other cases
{
    doublePrep(Setpoint);
}
doublePrep(Input);
sendBinary((int)(millis()-startTime)); //send the current operating time
sendBinary(ForcePID.GetMode()); //send whether PID is on or off

```

```

//Position Update for Servos
flexor.write(flexorPos); //update flexor position
extensor.write(extPos); //update extensor position

}

/*Communication Functions*/
/*-----*/
void sendBinary (int value) //converts int to bytes for Serial Communication
{
  Serial.write(lowByte(value));
  Serial.write(highByte(value));
}

void doublePrep (double number) //converts doubles to bytes for Serial communication
{
  char buf[10];
  String message = dtostrf(number,5,2,buf);
  Serial.write(message[0]);
  Serial.write(message[1]);
  Serial.write(message[2]);
  Serial.write(message[3]);
  Serial.write(message[4]);
  Serial.write('P');
}

/*Sensor Read Functions*/
/*-----*/
int valPotFlex() //Reads the potentiometer. Maps an angle. Returns as aperture mm
{
  double potValue = analogRead(ROT_POT);
  //Serial.print("Pot Value: ");
  // Serial.println(potValue); 1024 corresponds to 45mm
  //double aperture = modifiedMap(potValue,0,1024,0,45); //If doubles are required
  int aperture = map(potValue,0,1024,0,45);
  // Serial.print("Width: ");
  // Serial.println(aperture);
}

```

```

    return aperture;
}

double valLoadCell() //Reads the Load Cell. Maps a Force. Returns force in lbs as double
                    //42ADC--> 0lbs 1024ADC ---->5lbs /22.241Newtons
{
    int loadcellValue = analogRead(Load_Cell);
    //Serial.print("Pot Value: ");
    //Serial.println(loadcellValue);
    double force = modifiedMap(loadcellValue,0,1023,0.0,5.0); //if you want the answer in lbs
    if(force<.35)
    {
        force=0;
    }
    force = modifiedMap(force,0,5,0.0,22.241); //if you want the answer in newtons
    //Serial.print("Force: ");
    //Serial.println(force);
    return(force);
}

int inputEmg() //Reads EMG input & returns value
{
    int inputE= analogRead(EMG_Signal);
    double emgValue=70;

    if(inputE>=522) //if it is a flexor signal
    {
        int input_emg= constrain(inputE,522,1023);

        emgValue = constrain(map(input_emg,522,1023,MIN_Flexor,MAX_Flexor),MIN_Flexor,MAX_Flexor);
                        //signal between 60&140

        if((int)emgValue%2!=0) //if an odd number
        {
            emgValue++;
        }
    }

    else
    {
        emgValue=-44; //reset signal
    }
}

```

```

    return((int)(emgValue));
}

double modifiedMap(double x, double in_min, double in_max, double out_min, double out_max)
    //used to map using double variables
{
    double temp = (x - in_min) * (out_max - out_min) / (in_max - in_min) + out_min;
    return temp;
}

    /*Device Rest State Management*/
    /*-----*/
void zeroServos () //release all tension from the servos
{
    flexor.write(0); //flexor to zero
    extensor.write(0); //extensor to zero
}

int startUp() //used to discover and set initial servo positions
{
    int startPoint3=0;
    zeroServos();// set positions to zero
    delay(1000);
    extensor.write(MID_ExtAngle);
    delay(1500);
    while(valPotFlex(>36)
    {
        startPoint3++;
        flexor.write(startPoint3);
        delay(50);
    }
    return(startPoint3); //return starting extensor position command
}

    /*Device Operation Functions*/
    /*-----*/
double setpointMod(double z, double dx, double F) //returns desired setpoint as a double
{
    double Fc=0; //if no contact do not increase the setpoint
    if(F>0) //if contact has been made, increase by this relation
    {
        Fc = dx*z + F;
    }
}

```

```

return(Fc);
}

void movePlan(int desiredLocation) //Read EMG, Determine movement, Plan Trajectory
                                   //80-140 max move of 60
{
  int neg=1; //difference is positive
  //int difference = inputEmg(extPos) - flexorPos; //distance of desired move
  int difference = desiredLocation - flexorPos; //distance of desired move
  if(difference<0) //if negative, keep track, but recast as a positive number
  {
    difference=constrain(abs(difference),0,60); //abs value of move
    neg=-1; //set negative for later
  }
  else
  {
    difference=constrain(abs(difference),0,60);
  }

  if(difference%2!=0 && difference<20) //if an odd number
  {
    difference++;
  }

  if(difference>=20 && difference%4 != 0)
  {
    difference = 4 - (difference%4) + difference;
  }

  if(difference<10 && difference>0) //less than 10degrees
  {
    for(int k=0;k<difference;k++) //modify spot in the array
    {
      trajArray[k]=1*neg; //move by one
    }
    //neededInterval=30;
    //neededInterval=15; //choose how quickly to run
    neededInterval=10;
  }
  if(difference>=10 && difference<20) //between 10 and 20degrees
  {

    for(int k=0;k<difference/2;k++) //modify spot in the array

```



```

    {
        trajArray[k]=2*neg; //move by 2
    }
    //neededInterval=60;
    //neededInterval=30;
    neededInterval=20;
}
if(difference>=20) //greater than 20 max of 60 degrees for 15 spots
{
    for(int k=0;k<difference/4;k++) //modify spot in the array
    {
        trajArray[k]=4*neg; //move by 4
    }
    //neededInterval=120;
    //neededInterval=60;
    neededInterval=40;
}
}

/*AutoSelection Functions*/

void autoSelect () // Run Mode 2
{
    double Zn= tubeld(); //store tube information
    double Zlimit= constrain(Zn,.4,.8);
    z=modifiedMap(Zlimit,.4,.8,.15,.30); //select a Z based on Zn scaled between the two
    kp=183.75*z*z-105.66*z+18.607; //modify Kp according to z
    ForcePID.SetTunings(kp,ki,kd); //modify the Tuning Parameters
    DeviceMode=3;

    // Serial.print("Zn: ");
    // Serial.println(Zn);
    // Serial.print("Zc: ");
    // Serial.println(z);
    // Serial.print("Kp: ");
    // Serial.println(kp);
}

double tubeld ()
{
    double z1=zFinder();
    delay(100);
    double z2=zFinder();
}

```

```

    return((z1+z2)/2);
}
double zFinder () //check the tube stiffness
{
    flexorPos=MIN_Flexor;
    flexor.write(flexorPos);
    extensor.write(MID_ExtAngle);
    delay(80);

    double initialForce= makeContact(); //command flexion until contact is made
    double initialContact=valPotFlex(); //store position
    double finalPosition=smallSqueeze(); //move flexor and return final position

    double stiffness= -1*(valLoadCell()-initialForce)/(finalPosition-initialContact);

    flexorPos=MIN_Flexor;
    flexor.write(flexorPos);
    return(stiffness);
}

double makeContact() //move until tube contact
{
    double contactForce=0; //keep track of force

    while(contactForce==0) //move flexor until contact
    {
        flexorPos++;
        flexor.write(flexorPos);
        delay(30);
        contactForce=valLoadCell(); //update current force
    }

    return(contactForce); //return contact force
}

double smallSqueeze() //return position after squeezing
{
    for(int i=0;i<6;i++)
    {
        flexorPos++;
        flexor.write(flexorPos);
        delay(30);
    }
}

```

```

    return(valPotFlex()); //return position
}

void resetMode()
{
    extPos= MID_ExtAngle; //set ext pos to 20 //65
    flexorPos= MIN_Flexor; //flexorPos=startUp(); //ext pos = 47// 20 //65// retrieve flexorPos for
    tension likely

    ForcePID.SetMode(MANUAL); //ignore and turn off when opening
    Output=extPos; //Eliminates Bump

    //extensor.write(extPos); //move ext
    //flexor.write(flexorPos); //move flex
}

void systemStateIndicator(int state)
{
    //write all systems low
    if(state==1)
    {
        digitalWrite(rest,HIGH);
        digitalWrite(select,LOW);
        digitalWrite(active,LOW);
    }
    if(state==2)
    {
        digitalWrite(rest,LOW);
        digitalWrite(select,HIGH);
        digitalWrite(active,LOW);
    }
    if(state==3)
    {
        digitalWrite(rest,LOW);
        digitalWrite(select,LOW);
        digitalWrite(active,HIGH);
    }
    //turn on only the current state LED color
    digitalWrite(state, HIGH);
}

```

# LabVIEW VI

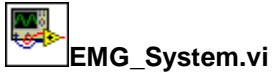

**Calibration**      Modify Rest & Max Settings

rms value 0	Resting Ext 0	Max Ext 1	Normalized Signal Ext 0	high cutoff freq: fh 400.00
rms value 2 0	Resting Flex 0	Max Flex 1	Normalized Signal Flex 0	low cutoff freq: fl 20.0000
				rate 2500

stop (F)

**Algorithm Select**

1      2      3

Digital      Proportional      Nonlinear

**Algorithm Output**  
0

Signal Outputs every roughly every 100ms

**Waveform Chart**      Plot 0

Amplitude

Time

**Meter**

-40      -30      -20      -10      0      10      20      30      40

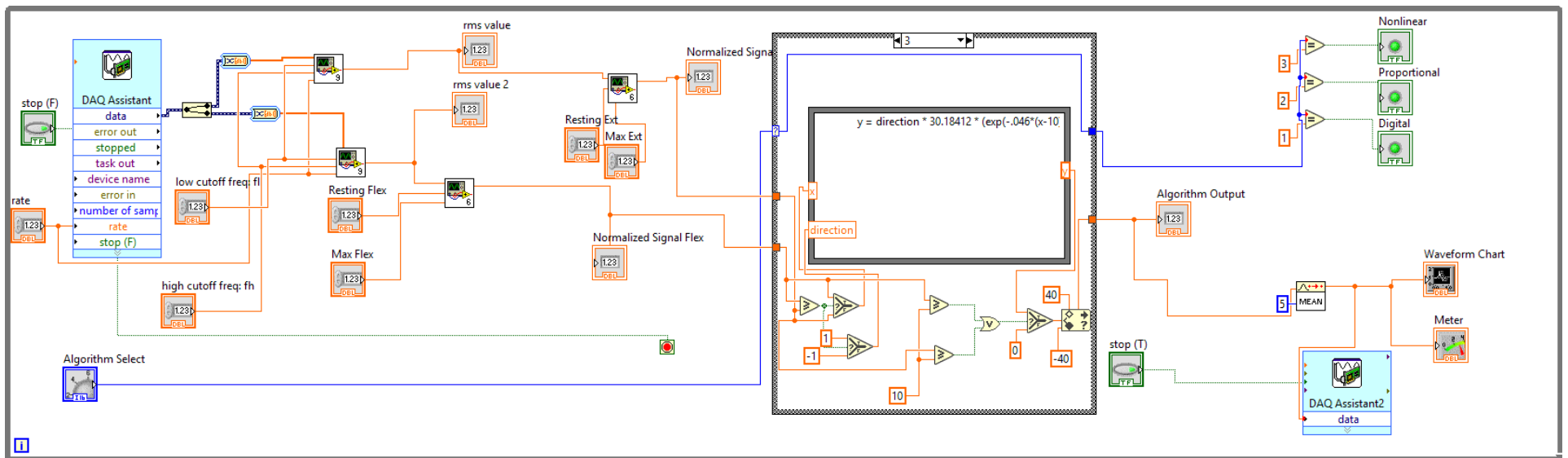

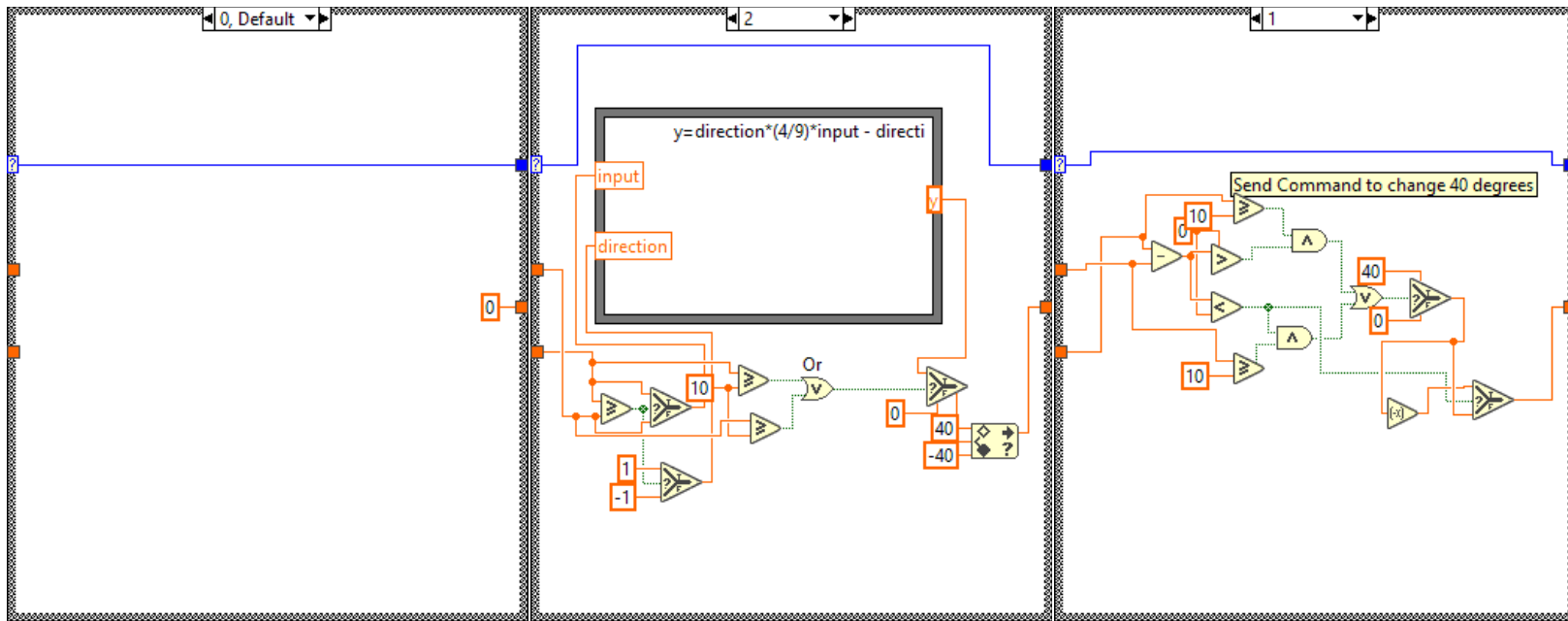

### Signal\_Normalize.vi

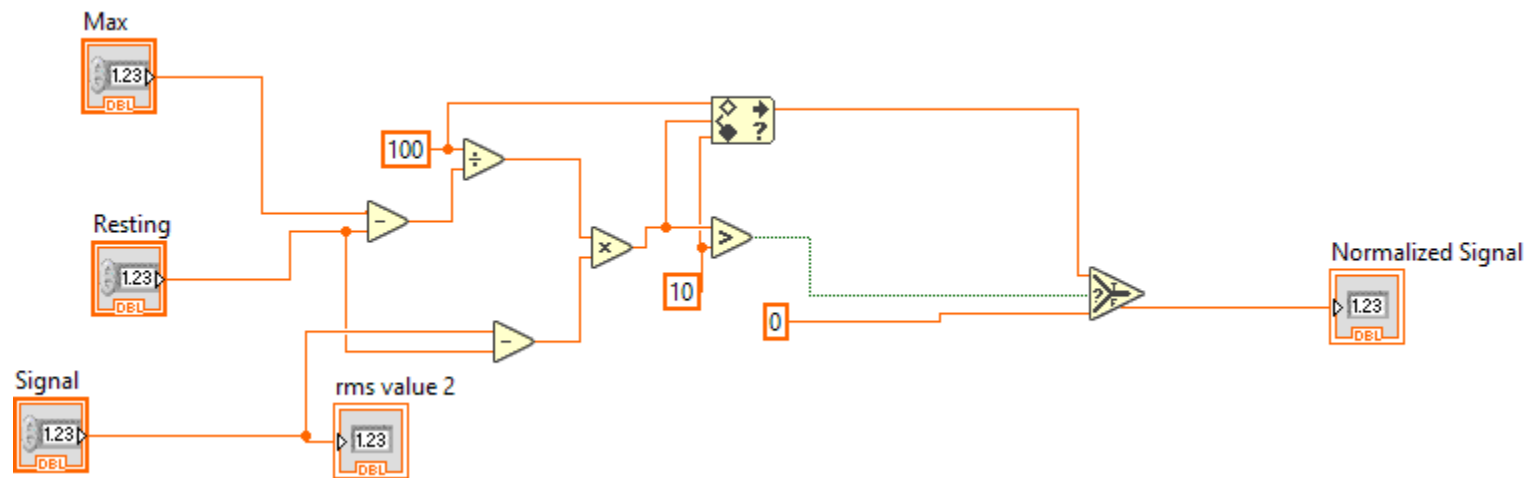
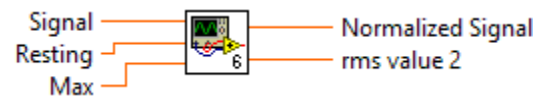

## EMG\_Rectify\_RMS.vi

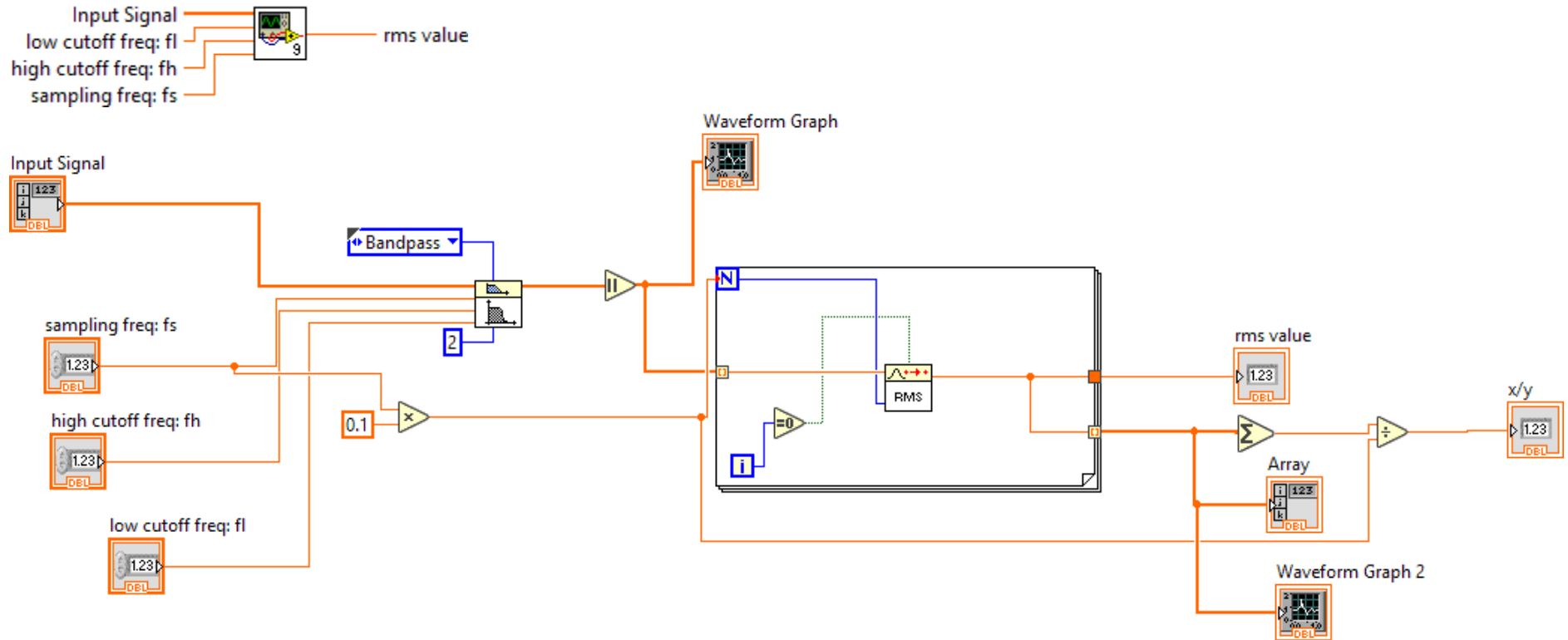

### NI\_PtbyPt.Ivlib:RMS PtByPt.vi

C:\Program Files (x86)\National Instruments\LabVIEW 2017\vi.lib\ptbypt\Probability & Statistics.llb\RMS PtByPt.vi



### NI\_AALBase.Ivlib:Butterworth Filter (DBL).vi

C:\Program Files (x86)\National Instruments\LabVIEW 2017\vi.lib\Analysis\3filter.llb\Butterworth Filter (DBL).vi



### NI\_AALBase.Ivlib:Filter Passband Type.ctl

C:\Program Files (x86)\National Instruments\LabVIEW 2017\vi.lib\Analysis\3filter.llb\Filter Passband Type.ctl



### NI\_AALBase.Ivlib:Butterworth Filter.vi

C:\Program Files (x86)\National Instruments\LabVIEW 2017\vi.lib\Analysis\3filter.llb\Butterworth Filter.vi



### ***Optional Processing Code for Storing Information to a .csv file***

```
//Processing Receive Binary Data - Write to a .csv file//

//String fileName= "2_Test8_Pink_Z_3-K_kp(z)_25_.085.csv"; //example naming format
String fileName= "pinkTube1.csv";

import processing.serial.*;

Serial myPort; //create object from serial class
//WARNING!
// If necessary change the definition below to the correct port

short portIndex = 1; //select the com port, 0 is the first port
char HEADER = 'H'; //character to identify the start of a message
int Aperture, FlexorPos, ExtPos, Time, Mode; //data from serial port
String Setpoint_prep = "BLANK!";
String Input_prep="BLANK!";
float Setpoint, Input, Error;
PrintWriter output;
int k=1, smoothing=0;

void setup()
{
  size(600,600);
  String portName = Serial.list()[portIndex];
  // println(Serial.list());
  // println("Connecting to ->" + Serial.list()[portIndex]);
  myPort = new Serial(this,portName,9600);
  output = createWriter(fileName);
}

void draw()
{
  if(k==1)
  {
    println("Time" + "," + "Aperture" + "," + "FlexorPos" + "," + "ExtPos" + "," + "Setpoint" + "," + "Input" +
    "," + "Error" + "," + "Mode");
    output.println("Time" + "," + "Aperture" + "," + "FlexorPos" + "," + "ExtPos" + "," + "Setpoint" + "," +
    "Input" + "," + "Error" + "," + "Mode");
    k++;
  }
}
```

```

//read the header and the following data
if(myPort.available() >=22) //If at least 21 bytes are available
{
  if(myPort.read()==HEADER) //is this the header?
  {
    Aperture=myPort.read(); //read Least significant byte
    Aperture=myPort.read()* 256 + Aperture; //add the most significant byte

    FlexorPos =myPort.read(); //read LSB
    FlexorPos =myPort.read()*256 + FlexorPos; //add most significant byte
    if(FlexorPos>500)
    {
      FlexorPos=-1;
    }

    ExtPos =myPort.read(); //read LSB
    ExtPos =myPort.read()*256 + ExtPos; //add most significant byte

    Setpoint_prep= myPort.readStringUntil('P');
    if(Setpoint_prep.charAt( Setpoint_prep.length()-1) == 'P' )
    {
      Setpoint_prep = Setpoint_prep.substring( 0, Setpoint_prep.length()-1 );
    }
    Setpoint = float(Setpoint_prep);

    Input_prep= myPort.readStringUntil('P');
    if(Input_prep.charAt( Input_prep.length()-1) == 'P' )
    {
      Input_prep = Input_prep.substring( 0, Input_prep.length()-1 );
    }
    Input = float(Input_prep);

    Error=Setpoint-Input;

    Time =myPort.read(); //read LSB
    Time =myPort.read()*256 + Time; //add most significant byte

    Mode =myPort.read();
    Mode =myPort.read()*256 + Mode;

```

```

if(Mode>=0)
{
    smoothing=Mode;
}
else
{
    Mode=smoothing;
}

println(Time + "," + Aperture + "," + FlexorPos + "," + ExtPos + "," + Setpoint + "," + Input + "," + Error
+ "," + Mode);
    output.println(Time + "," + Aperture + "," + FlexorPos + "," + ExtPos + "," + Setpoint + "," + Input + ","
+ Error + "," + Mode);
}
}
background(255); //Set background to white
fill(0); //set fill to black

rect(0,0,Aperture,FlexorPos); //draw rectangle with integers received from arduino

}

void keyPressed() //stop the program by pressing the keyboard
{
    output.flush();
    output.close();
    exit();
}

```

## Appendix B: Device Design Documents

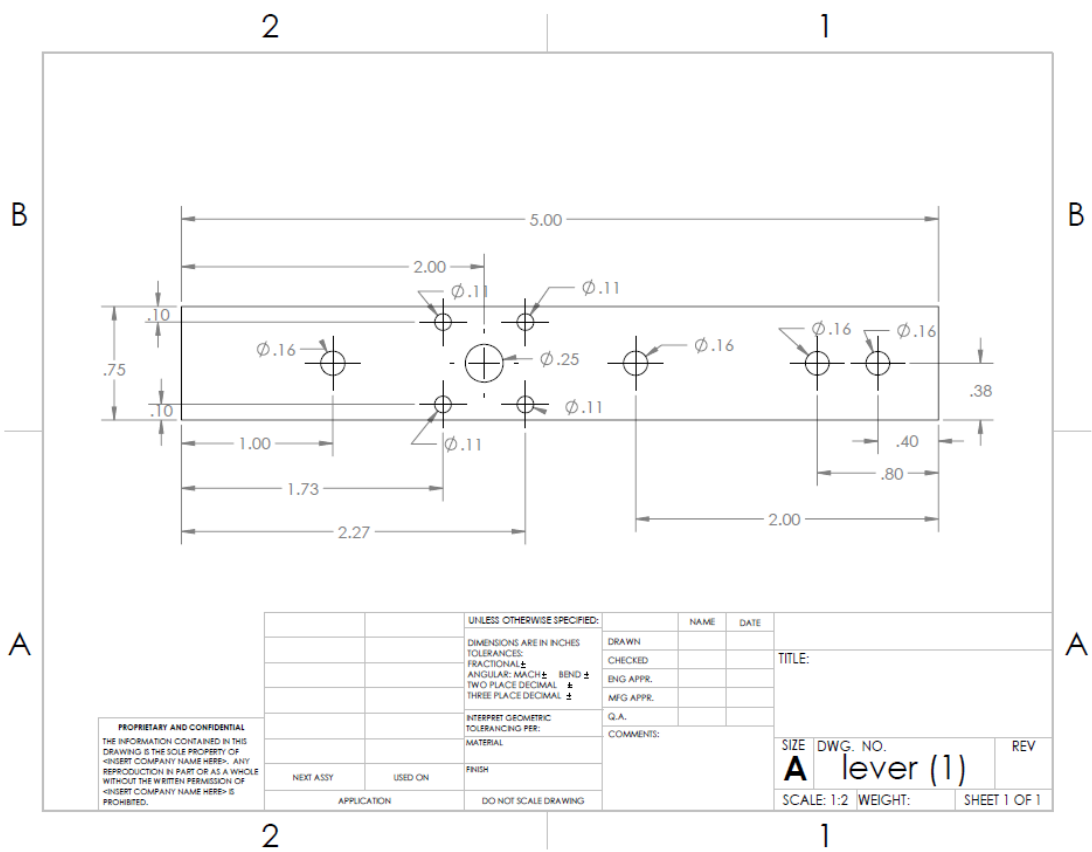
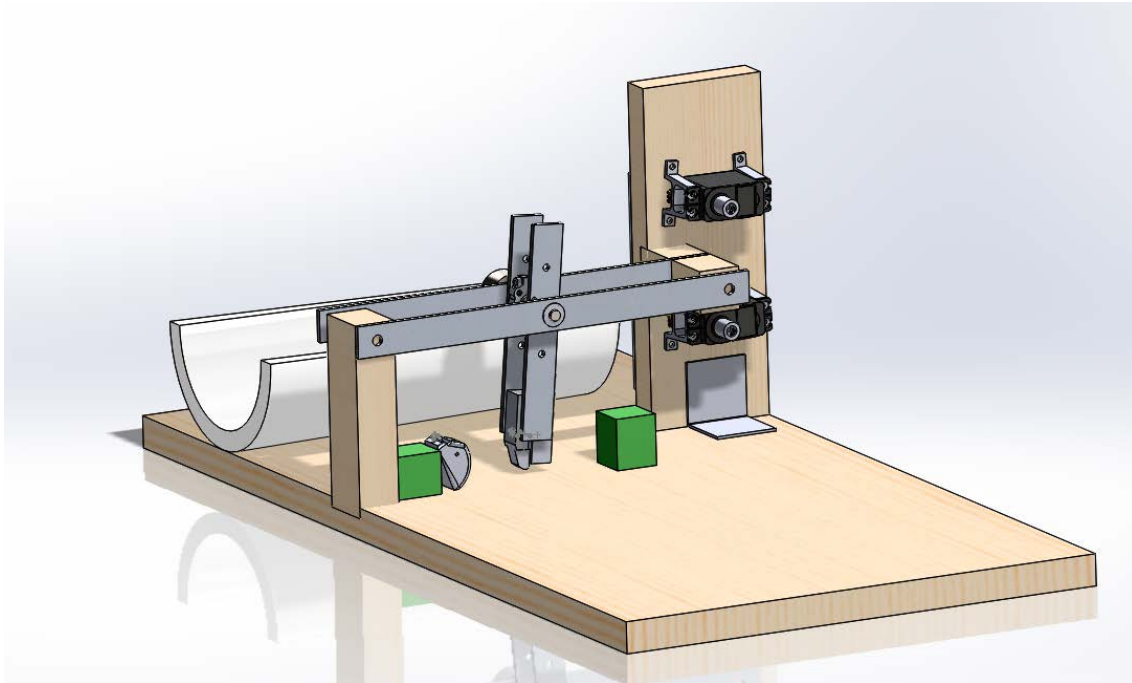

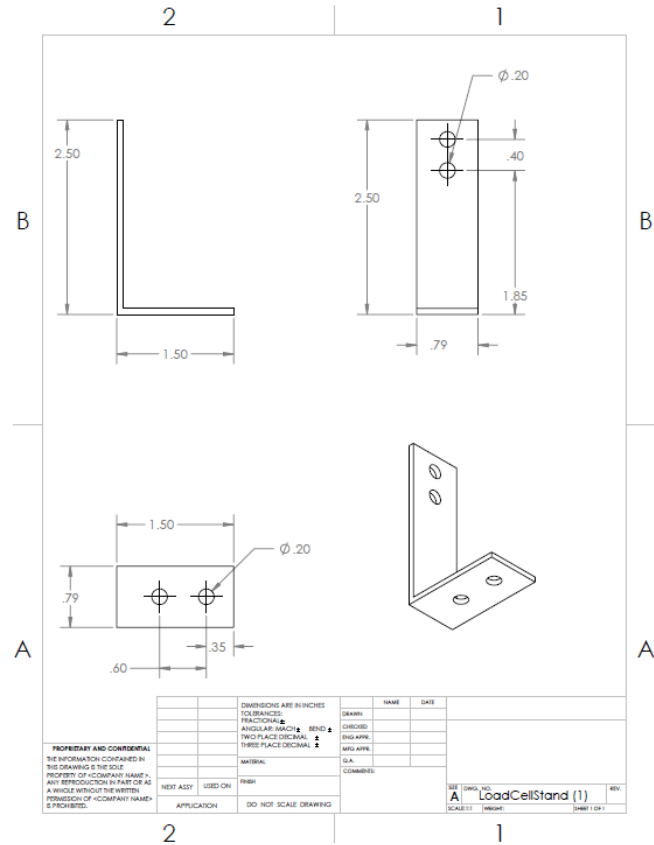
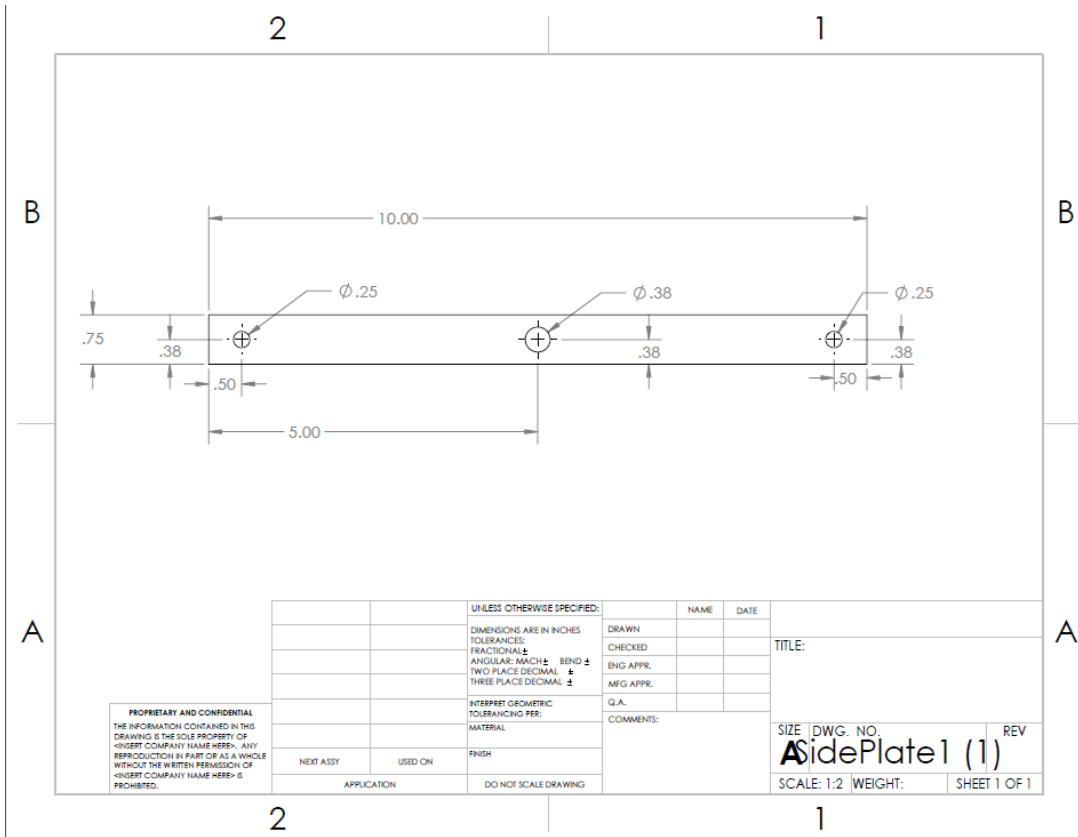

## Appendix C: Testing Forms & Protocols

### **RESEARCH SUBJECT INFORMATION AND CONSENT FORM**

**TITLE: Assessment of Vibratory Feedback for Grip Control VCU IRB NO.: HM20008516**

**INVESTIGATOR: Dianne Pawluk**

If any information contained in this consent form is not clear, please ask the study staff to explain any information that you do not fully understand. You may take home an unsigned copy of this consent form to think about or discuss with family or friends before making your decision.

#### **PURPOSE OF THE STUDY**

The method by which the grip of a motorized prosthetic hand is open and closed can affect the performance of the prosthetic and ease of use during grasping and manipulation tasks. The purpose of this research study is to examine the performance and ease of use of three different methods of controlling grasping by a test model of a hand prosthetic involved in two common activities of daily living that require two hands.

You are being asked to participate in this study because you are over the age of 18.

#### **DESCRIPTION OF THE STUDY AND YOUR INVOLVEMENT**

If you decide to be in this research study, you will be asked to sign this consent form after you have had all your questions answered and understand what will happen to you.

You will be asked to perform two two-handed activities of daily living with your right hand and the test model of a prosthetic hand. In the first task, you will be required to cut different objects with a knife in your right hand while the object is held on a cutting board by the prosthetic hand. In the second task, you will be required to hold a toothbrush in your right hand while you squeeze paste out of a tube with the prosthetic hand to place a certain amount on the toothbrush. You will be asked to use three different methods to control the test model of a prosthetic hand during these tasks, which will be used in random order. For each method, you will be trained using the method on the specific task before you begin testing.

The three different methods use different combinations of (a) recordings from muscle activity in your left arm using surface electromyography and (b) automatic control by the test model prosthetic itself. Surface electromyography is a non-invasive method that records the electrical signals of muscles contracting from recording sites on the surface of the skin. For the first method, you will generate muscle activity to control the distance between the thumb and fingers during the grasp and the prosthesis will automatically adjust the contact behavior. In the second method, you will generate muscle activity at two sites to control both the distance between the thumb and fingers and the contact behavior. In the third method, you will generate muscle activity at a single site to first control the distance between the thumb and fingers and then switch to controlling the contact behavior.

Significant new findings developed during the course of the research which may relate to your willingness to continue participation will be provided to you.

### **RISKS AND DISCOMFORTS**

For operating the test model of a prosthetic hand, you will need to place your left arm in a hemi-spherical plastic sleeve and allow surface electromyography electrodes to be adhered to your arm using a gel. The surface electromyography electrodes look the size and shape of a quarter, attached to wires. The gel will be used to adhere the “quarters” to your arm. It is possible that the gel and the plastic sleeve may produce some discomfort. If you experience discomfort, you can ask the study staff to take a break at any time and terminate the study if you desire. It is also possible that the electrodes may give you an electric shock, although the voltage is too low to cause harm.

For the first task, which involves cutting with a knife, there is a risk of being cut. However, in this task, the prosthesis is only used to hold the object while you cut with the knife with your right hand directly. Thus, the risk is less than a normal cutting task at home as you do not hold the object with a bare hand. In addition, the test model prosthetic fingers can only open and close the grip, and is unable to make any other types of movements, minimizing risk from the prosthetic itself. Also, when learning any new task, you may become frustrated. You will be allowed to rest upon request or terminate the study for any reason.

What we find from this study may be presented at meetings or published in papers, but your name will not ever be used in these presentations or papers.

### **BENEFITS TO YOU AND OTHERS**

You may not get any direct benefit from this study, but, the information we learn from people in this study may help us design better prosthetics and prosthetic control methods for amputees.

### **COSTS**

There are no costs for participating in this study other than the time you will spend.

### **PAYMENT FOR PARTICIPATION**

You will be paid \$30 for being in this study. You will be paid \$15 for completion of the first task and \$15 for completion of the second task.

You may be asked to provide your social security number in order to receive payment for your participation. Your social security number is required by federal law. It will not be included in any information collected about you for this research. Your social security number will be kept confidential and will only be used in order to process payment.

## **ALTERNATIVES**

The alternative is not to participate.

## **CONFIDENTIALITY**

Potentially identifiable information about you will consist of position and force data collected from the sensors of the prosthetic hand, as well as a score of our completion of each task. Data is being collected only for research purposes.

Your data will be identified by ID numbers, not names, and stored separately from research data in a password protected database on a computer. Personal identifying information is only needed for payment and will be deleted after 6 months of completing the study. If you have not received payment before this time, you should notify the study staff. Sensor data and task completion scores will be kept in a password protected database for 5 years after the study ends and will be destroyed at that time.

Access to all data will be limited to study personnel.

Information from the study and information and the consent form signed by you may be looked at or copied for research or legal purposes by Virginia Commonwealth University. Personal information about you might be shared with or copied by authorized officials of the Department of Health and Human Services or other federal regulatory bodies.

What we find from this study may be presented at meetings or published in papers, but your name will not ever be used in these presentations or papers.

## **VOLUNTARY PARTICIPATION AND WITHDRAWAL**

Your participation in this study is voluntary. You may decide to not participate in this study. Your decision not to take part will involve no penalty or loss of benefits to which you are otherwise entitled. If you do participate, you may freely withdraw from the study at any time. Your decision to withdraw will involve no penalty or loss of benefits to which you are otherwise entitled.



Your participation in this study may be stopped at any time by the study staff without your consent. The reasons might include:

- the study staff thinks it necessary for your health or safety;
- you have not followed study instructions;
- the sponsor has stopped the study; or
- administrative reasons require your withdrawal.

There are no consequences if you leave the study early.

## **QUESTIONS**

If you have any questions, complaints, or concerns about your participation in this research, contact:

**[Dianne Pawluk, [dtpawluk@vcu.edu](mailto:dtpawluk@vcu.edu), 804-828-9491]**

The researcher/study staff named above is the best person(s) to call for questions about your participation in this study.

If you have any general questions about your rights as a participant in this or any other research, you may contact:

Office of Research

Virginia Commonwealth University 800 East Leigh Street, Suite 3000

P.O. Box 980568 Richmond, VA 23298 Telephone: (804) 827-2157

Contact this number to ask general questions, to obtain information or offer input, and to express concerns or complaints about research. You may also call this number if you cannot reach the research team or if you wish to talk with someone else. General information about participation in research studies can also be found at [http://www.research.vcu.edu/human\\_research/volunteers.htm](http://www.research.vcu.edu/human_research/volunteers.htm).

**CONSENT**

I have been given the chance to read this consent form. I understand the information about this study. Questions that I wanted to ask about the study have been answered. My signature says that I am willing to participate in this study. I will receive a copy of the consent form once I have agreed to participate.

---

Participant name printed      Participant signature      Date

---

Name of Person Conducting Informed Consent Discussion (Printed)

---

Signature of Person Conducting Informed Consent Discussion      Date

---

Principal Investigator Signature (if different from above)      Date

## Participants Invited

We are performing a study to assess a prototype method using surface electromyography (recording signals from arm muscles) to control a prosthetic hand. In this study, you will be required to perform an activity that normally occurs during daily living. You will be asked to control the prosthetic hand to squeeze a tube of paste to place the paste on a toothbrush helped by your right hand.

We are now recruiting right handed subjects for our research study. This study requires that you participate in 1 approximately 3 hour testing session. The study will take place in Biotech 8 the Biotech Park (corner of Jackson and Navy Hill Drive, near MCV campus)

We are looking for participants over the age of 18.

Contact:

Chris Aymonin (804) 828-7839 [aymonincj@vcu.edu](mailto:aymonincj@vcu.edu)

or

Dianne Pawluk (804) 828-9491 [dpawluk@vcu.edu](mailto:dpawluk@vcu.edu), Department of Biomedical Engineering, Virginia Commonwealth University, Monday through Friday, 9am to 5pm.

Compensation will be \$30 if you complete the study.

## Apparatus Setup Checklist

**Fill the Standard with fluid and set on the testing platform**

**Put the scale in front the computer**

**Adjust subject's seat to the top**

**Put clamps into place**

**Grab Roll of Paper Towels**

**Set out electrode pack**

**Print out consent form**

## Data Collection Checklist

### **Create folder for Subject Data**

Location: Desktop -> Device Testing -> System Recording

Filename: Subject\_'n'

### **Open LabVIEW, Arduino, and Processing**

Location: Desktop-> Device Testing

AutoPositionImpedanceController\_11\_13.ino

EMG\_System.vi

SystemRecording.pde

### **Arrange Programs**

LabView: Right Screen (Moveable)

Arduino: Middle Screen

Processing: Left Screen

## Device Setup Checklist

### **Turn on Myosystem 1400A. Select Gain of 10**

Flip switch on the back right side of the device

Press Enter to get to the system settings

Use the left set of arrows to move the cursor to the gain selection

Press Enter until a gain of 10 and Press Esc to exit

### **Plug in Arduino USB to the left side of the right monitor**

### **Turn On DC Source**

Power On

Turn Output ON

-25V set dial to -15V

+25V set dial to 15V

+6V set to 6V

**Press Output ON/OFF Button to stop system until testing begins**

## Device Inspection Checklist

### **Check yellow Kevlar ropes for fraying**

If about to break, make measurement of flexor and extensor cord lengths and record them here in the machines default position.

Flexor \_\_\_\_\_ Extensor \_\_\_\_\_ Extensor \_\_\_\_\_

### **Check the thumb attachment to the load cell to ensure it is fixed in place**

If loose, tighten it.

### **Check for stability of the tube holder**

Ensure that the metal end is contacting the wood and beneath the metal bracket on the opposite side so that it does not lift during operation.

## Wire Inspection Checklist –most commonly loose cables

### **Potentiometer cables disconnected**

Yellow →Green

Orange →Blue

Green → Red

### **EMG Cable disconnect**

Blue → Green

Orange →Red

25 pin connector

Pin 5 Red Wire

Pin 6 Green Wire

Ensure Green Cable connected to shield

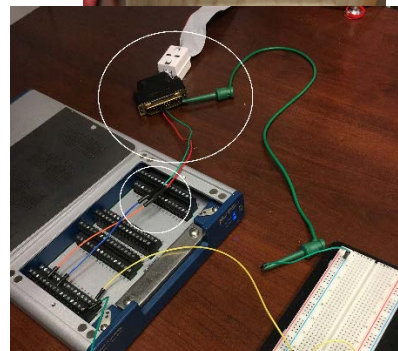
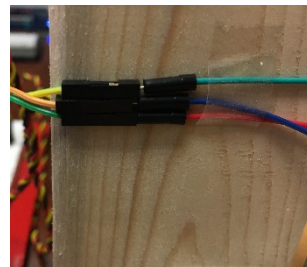

### **Check the DC Power Supply Cables are attached to the Breadboard**

+15V to the left Green Socket

-15V to the left Yellow Socket

+6V to the left Red Socket

GND to the left Black Socket

# Experimental Protocol

## **Greet Subject**

**Go over the consent form Highlights**

**Give time for subject to read consent form**

**Ask them if they have any questions**

**Ask them to sign consent form**

**Store signed consent form & Payment Forms (2 signatures required for payment)**

**Read the following Introduction**

In this study, you will be required to squeeze tubes with pastes of different consistencies with your left hand (real or simulated) and place a specified amount on a popsicle stick held by your right hand.

You will do one block of trials using your left hand directly squeezing the tube. You will do another block of trials using your left hand to control a prosthetic simulator using EMG commands. The block you will get first will be randomized across subjects.

**[Proceed to Prosthetic or Human Hand Section]**

## **[Human Hand Experiment Script]**

In this experiment, you will be asked to perform a squeezing motion on a tube, held in a holder, using a tri-fingered grasp with your left hand. You are to squeeze a specified amount of paste onto a popsicle stick held by your right hand. The volume of paste to be squeezed is shown in the container **<show container>** and on a popsicle stick **<show popsicle stick with prescribed paste on it>**.

The different colored containers contain different consistencies of the paste. You should adjust your grasp as needed to accurately control the paste being extruded to obtain the specified volume.

During each trial, I will place a new tube in the holder and pretension it with a clamp.

I will then hand you a Popsicle stick which you should hold as shown **<show participant>**

Then, using your left hand in a tri-fingered grasp position, apply pinching pressure to the tube at a point between the clamp and the plastic neck of the tube. **<Demonstrate proper grasp and specify the location>**

Your task is to squeeze out an amount of paste onto the popsicle stick that is equal to the amount shown in this sample **<Show them again the display sample and place on the table>**

You should consider any paste that sticks to the nozzle of the tube as part of the volume you are collecting. You may raise the popsicle stick held in your right hand vertically to cut off the flow from the

tube at the desired amount and scrape any paste from the nozzle of the tube onto the top of the popsicle stick. You should use only one side of the stick to collect the paste. If any paste falls on the tray, you should not touch it.

When you are finished, hand me the stick with the paste.

**Subject Positioning**

If you need to adjust your chair, please do so now. You will not be able to adjust the chair during the experiment.

**Task Trials**

9 trials should then be presented. You should save the popsicle sticks to record the weight (and convert it to a volume). You should also record the weight (and convert to a volume) any paste that has fallen on the tray. You should also record the response time from when they first started squeezing the tube until when they stopped.

For each trial:

Set-up the tube

Hand the user the popsicle stick

Remind them of the volume

Tell them to grasp the tube, and begin recording the time.

When finished, stop recording the time and set the popsicle stick aside (popsicle sticks should be labelled by their trial number)

## [Prosthetic Experiment Script]

### **Introduction**

In this experiment, you will be asked to perform a squeezing motion on a tube, held in a holder, using the two prosthetic fingers. You are to squeeze a specified amount of paste onto a popsicle stick held by your right hand. The volume of paste to be squeezed is shown in the container <show container> and on a popsicle stick <show popsicle stick with prescribed paste on it>.

The different colored containers contain different consistencies of the paste. The grasp should be adjusted as needed to accurately control the paste being extruded to obtain the specified volume. The grasp will be adjusted by two components. You will be able to control the opening and closing of the grasp using an EMG signal from your left arm. A built-in algorithm will automatically adjust the stiffness of the fingers based on the paste being used.

EMG senses the electrical activity from muscles. You will use the muscles of your forearm to change the position of one of the fingers of the device in order to perform a squeezing motion on a tube. The other finger will remain fixed.

I will place electrode pairs over the muscles in your forearm, and ask you to contract those muscles to allow you to control the finger motion.

If you are ready, we will begin by applying the electrodes and giving you time to practice controlling the finger with the contraction of your forearm muscles. I will apply the electrodes on your left forearm.

### **[Apply the Electrodes]**

#### **Subject Positioning**

Now that the electrodes have been applied, please place your left forearm on the desk to the left of the device and your right arm to the right of the device. If necessary, adjust the height of the chair to a comfortable height where you can reach the platform. I will now attach cables to the electrodes.

#### **[Apply the Electrode Cables]**

Place your left hand on the post to your left so that the pads of your fingers are in contact with the post and your wrist is resting on the desk. If necessary, I can adjust the post to be closer or farther away. Try to find a position where your hand is completely straight with your fingertips able to contract against the post with minimal effort.

If you are comfortable with this position. We will continue setting up the system.

#### **Calibration**

We will now calibrate the system so that it will learn to respond to your muscle signals in a predictable way. I will ask you to rest and contract each of the muscles in order to get a baseline and a max contraction. When using the device, flex using a combination of finger and wrist muscles while keeping your arm in place. While keeping your arm in place, push against the post using the pads of your fingers.

It is not necessary to contract so hard that it is stressful on your arm. The system will be calibrated to a scale that is most comfortable to you.



## **[Adjust Thresholds for Resting and Max Contraction for Flexor and Extensor]**

### **Finger Control Training**

The device will open and close its fingers in relation to your flexing motion. This is your primary means of controlling how much the tube is squeezed. However, you should be aware that there is a built-in algorithm that will also adjust the stiffness of the squeeze based on the consistency of the paste in the tube. If the consistency of the paste is less stiff, the fingers will be more “floppy”. If the consistency of the paste is more stiff, the fingers will be more rigid.

In terms of moving the finger, if the device does not respond properly to your commands, a recalibration can be done.

### **[Flip Screen with LabVIEW so that User can see]**

In order to get an idea of how much you are squeezing the tube, attempt to reach the target values 10 times in a row at the specified level. You can see how much the device would move rated from 0 to 40 on the gauge and on the graph to the right.

**[Ask them to hit 10, 20, 30, and 40 ten times in a row returning to 0 between each time]**

**[Ask them to practice hitting levels of 10, 20, 30, and 40 consecutively 5 times in a row]**

**[Ask them to practice hitting levels of 40, 30, 20, and 10 consecutively 5 times in a row]**

**[Ask them to hit 20, 40, 30, 10 consecutively 3 times in a row]**

Extending your wrist away from the post and holding it in place will cause the device to begin an autosensing mode. You will use this command in order start operating the prosthetic simulator.

**[Demonstrate the transition signal by holding your wrist in extension.]**

**[Ask them to demonstrate the signal by holding the EMG at -40 for 3 seconds 5 times]**

When you feel comfortable changing your command signals, we will proceed to testing.

### **Task Description**

As a reminder, in this experiment, you will be asked to perform a squeezing motion on a tube, held in a holder, using a prosthetic simulator of two fingers. You are to squeeze a specified amount of paste onto a popsicle stick held by your right hand. The volume of paste to be squeezed is shown in the container **<show container>** and on a popsicle stick **<show popsicle stick with prescribed paste on it>**.

The different colored containers contain different consistencies of the paste. You should adjust your grasp as needed to accurately control the paste being extruded to obtain the specified volume.

During each trial, I will place a new tube in the simulated prosthetic grasp and pretension it with a clamp.

I will then hand you a Popsicle stick which you should hold as shown <show participant>

The prosthetic device will reset and wait for your wrist extension command signal to start. Once you hold the extension signal [**Demonstrate it**], a green light [**Point to it**] will turn on and the device will squeeze lightly twice before it hands over control to you.

Relax your wrist completely and wait until the cycle ends and the light turns blue. At this time the device will follow your input.

Your task is to squeeze out an amount of paste onto the popsicle stick that is equal to the amount shown in this sample <Show them again the display sample and place on the table>

You should consider any paste that sticks to the nozzle of the tube as part of the volume you are collecting. You may raise the popsicle stick held in your right hand vertically to cut off the flow from the tube at the desired amount and scrape any paste from the nozzle of the tube onto the top of the popsicle stick. You should use only one side of the stick to collect the paste. If any paste falls on the tray, you should not touch it.

When you are finished, hand me the stick with the paste.

### **Task Trials**

9 trials should then be presented. You should save the popsicle sticks to record the weight (and convert it to a volume). You should also record the weight (and convert to a volume) any paste that has fallen on the tray. You should also record the response time from when they first started squeezing the tube until when they stopped.

For each trial:

Set-up the tube

Hand the user the popsicle stick

Remind them of the volume

Tell them to grasp the tube, and begin recording the time.

When finished, stop recording the time and set the popsicle stick aside (popsicle sticks should be labelled by their trial number)

## Subject Trial Order

Subject 1	Human Hand(2 <sup>nd</sup> task)			Device (1 <sup>st</sup> task)		
Trial	1	2	3	1	2	3
1	W	P	B	P	W	B
2	W	B	P	B	P	W
3	P	B	W	B	W	P

Subject 2	Device (2 <sup>nd</sup> task)			Human Hand (1 <sup>st</sup> task)		
Trial	1	2	3	1	2	3
1	P	W	B	W	B	P
2	W	P	B	B	P	W
3	B	W	P	P	B	W

Subject 3	Human Hand			Device		
Trial	1	2	3	1	2	3
1	W	B	P	P	B	W
2	P	W	B	W	P	B
3	B	W	P	B	P	W

Subject 4	Device			Human Hand		
Trial	1	2	3	1	2	3
1	B	W	P	P	W	B
2	W	B	P	W	P	B
3	P	B	W	B	P	W

Subject 5	Human Hand			Device		
Trial	1	2	3	1	2	3
1	W	P	B	P	W	B
2	P	B	W	B	P	W
3	B	W	P	W	B	P

Subject 6	Device			Human Hand		
Trial	1	2	3	1	2	3
1	P	B	W	W	P	B
2	W	B	P	B	W	P
3	B	P	W	P	W	B

### ***Tube Fluid Density Record***

Date Used	Bottle Name	Measured Mass (g)	Mass of Standard Container (g)	Mass of Fluid (g)	Volume Standard cm <sup>3</sup> )	Density of Batch(g/cm <sup>3</sup> )
11/24/18	P1	0.9	0.4	0.5	1.1	0.4545
11/24/18	W1	1	0.4	0.6	1.1	0.5455
11/24/18	B3	0.9	0.4	0.5	1.1	0.4545
11/26/18	W2	1	0.4	0.6	1.1	0.5455
11/26/18	B4	1	0.4	0.6	1.1	0.5455
11/26/18	P4	0.9	0.4	0.5	1.1	0.4545
11/27/18	P3	0	0.5	-0.5	1.1	-0.4545
11/27/18	W3	1	0.4	0.6	1.1	0.5455
11/27/18	B4	1.1	0.5	0.6	1.1	0.5455
11/30/18	P3	1.1	0.5	0.6	1.1	0.5455
11/30/18	W2	1.1	0.5	0.6	1.1	0.5455
11/30/18	B1	1.1	0.5	0.6	1.1	0.5455
12/1/18	W1	1.1	0.5	0.6	1.1	0.5455
12/1/18	P4	1.1	0.5	0.6	1.1	0.5455
12/1/18	B1	1.1	0.5	0.6	1.1	0.5455
12/2/18	P4	1.1	0.5	0.6	1.1	0.5455
12/2/18	W1	1.1	0.5	0.6	1.1	0.5455
12/2/18	B1	1.1	0.5	0.6	1.1	0.5455
12/2/18	P3	1.1	0.5	0.6	1.1	0.5455
12/2/18	B2	1.1	0.5	0.6	1.1	0.5455
12/2/18	W3	1.1	0.5	0.6	1.1	0.5455
12/2/18	P3	1.1	0.5	0.6	1.1	0.5455
12/2/18	B2	1.1	0.5	0.6	1.1	0.5455
12/2/18	W3	1.1	0.5	0.6	1.1	0.5455
12/3/18	W	1	0.5	0.5	1.1	0.4545
12/3/18	P	1.1	0.5	0.6	1.1	0.5455
12/3/18	B	1	0.5	0.5	1.1	0.4545

## Appendix D: Results Data

### Volume Extrusion Error: Estimated Marginal Means 1: Repetition

Repetition	Mean	Std. Error	95% Wald Confidence Interval	
			Lower	Upper
Repetition 1	.1317	.22096	-.3014	.5647
Repetition 2	.3072	.20369	-.0920	.7064
Repetition 3	.3172	.23874	-.1507	.7852

### Volume Extrusion Error: Pairwise Comparisons: Repetition

(I) Repetition	(J) Repetition	Mean Difference (I-J)	Std. Error	df	Sig.	95% Wald Confidence Interval for Difference	
						Lower	Upper
Repetition 1	Repetition 2	-.1756 <sup>a</sup>	.02264	1	.000	-.2199	-.1312
	Repetition 3	-.1856 <sup>a</sup>	.05739	1	.001	-.2980	-.0731
Repetition 2	Repetition 1	.1756 <sup>a</sup>	.02264	1	.000	.1312	.2199
	Repetition 3	-.0100	.06958	1	.886	-.1464	.1264
Repetition 3	Repetition 1	.1856 <sup>a</sup>	.05739	1	.001	.0731	.2980
	Repetition 2	.0100	.06958	1	.886	-.1264	.1464

Pairwise comparisons of estimated marginal means based on the original scale of dependent variable: Error  
a. The mean difference is significant at the .05 level.

### Volume Extrusion Error: Estimated Marginal Means 2: Color of Tube

Color of Tube	Mean	Std. Error	95% Wald Confidence Interval	
			Lower	Upper
Pink	.1319	.17459	-.2102	.4741
White	.4133	.23650	-.0502	.8769
Blue	.2108	.25906	-.2969	.7186

### Volume Extrusion Error: Pairwise Comparisons: Color of Tube

(I) Color of Tube	(J) Color of Tube	Mean Difference (I-J)	Std. Error	df	Sig.	95% Wald Confidence Interval for Difference	
						Lower	Upper
Pink	White	-.2814 <sup>a</sup>	.09235	1	.002	-.4624	-.1004
	Blue	-.0789	.10075	1	.434	-.2763	.1186
White	Pink	.2814 <sup>a</sup>	.09235	1	.002	.1004	.4624
	Blue	.2025 <sup>a</sup>	.09278	1	.029	.0207	.3843
Blue	Pink	.0789	.10075	1	.434	-.1186	.2763

	White	-.2025 <sup>a</sup>	.09278	1	.029	-.3843	-.0207
--	-------	---------------------	--------	---	------	--------	--------

Pairwise comparisons of estimated marginal means based on the original scale of dependent variable: Error  
a. The mean difference is significant at the .05 level.

Volume Extrusion Error: Estimated Marginal Means 3: Color of Tube \* Repetition

Color of Tube	Repetition	Mean	Std. Error	95% Wald Confidence Interval	
				Lower	Upper
Pink	Repetition 1	.0142	.19782	-.3736	.4019
	Repetition 2	.2142	.18687	-.1521	.5804
	Repetition 3	.1675	.16557	-.1570	.4920
White	Repetition 1	.2167	.21078	-.1965	.6298
	Repetition 2	.5008	.23126	.0476	.9541
	Repetition 3	.5225	.27093	-.0085	1.0535
Blue	Repetition 1	.1642	.26422	-.3537	.6820
	Repetition 2	.2067	.23809	-.2600	.6733
	Repetition 3	.2617	.28985	-.3064	.8298

Volume Extrusion Error: Pairwise Comparisons: Color of Tube \* Repetition

(I) Color of Tube*Repetition	(J) Color of Tube*Repetition	Mean Difference (I-J)	Std. Error	df	Sig.	95% Wald Confidence Interval for Difference	
						Lower	Upper
[Color of Tube=1]*[Repetition=1]	[Color of Tube=1]*[Repetition=2]	-.2000 <sup>a</sup>	.10085	1	.047	-.3977	-.0023
	[Color of Tube=1]*[Repetition=3]	-.1533 <sup>a</sup>	.06678	1	.022	-.2842	-.0225
	[Color of Tube=2]*[Repetition=1]	-.2025 <sup>a</sup>	.04008	1	.000	-.2811	-.1239
	[Color of Tube=2]*[Repetition=2]	-.4867 <sup>a</sup>	.07612	1	.000	-.6359	-.3375
	[Color of Tube=2]*[Repetition=3]	-.5083 <sup>a</sup>	.09899	1	.000	-.7024	-.3143

	[Color of Tube=3]*[Repetition=1]	-.1500	.09595	1	.118	-.3380	.0380
	[Color of Tube=3]*[Repetition=2]	-.1925 <sup>a</sup>	.08646	1	.026	-.3620	-.0230
	[Color of Tube=3]*[Repetition=3]	-.2475	.12696	1	.051	-.4963	.0013
[Color of Tube=1]*[Repetition=2]	[Color of Tube=1]*[Repetition=1]	.2000 <sup>a</sup>	.10085	1	.047	.0023	.3977
	[Color of Tube=1]*[Repetition=3]	.0467	.12428	1	.707	-.1969	.2903
	[Color of Tube=2]*[Repetition=1]	-.0025	.12706	1	.984	-.2515	.2465
	[Color of Tube=2]*[Repetition=2]	-.2867 <sup>a</sup>	.14042	1	.041	-.5619	-.0114
	[Color of Tube=2]*[Repetition=3]	-.3083	.18491	1	.095	-.6707	.0541
	[Color of Tube=3]*[Repetition=1]	.0500	.13122	1	.703	-.2072	.3072
	[Color of Tube=3]*[Repetition=2]	.0075	.15961	1	.963	-.3053	.3203
	[Color of Tube=3]*[Repetition=3]	-.0475	.19016	1	.803	-.4202	.3252
[Color of Tube=1]*[Repetition=3]	[Color of Tube=1]*[Repetition=1]	.1533 <sup>a</sup>	.06678	1	.022	.0225	.2842
	[Color of Tube=1]*[Repetition=2]	-.0467	.12428	1	.707	-.2903	.1969
	[Color of Tube=2]*[Repetition=1]	-.0492	.07219	1	.496	-.1907	.0923
	[Color of Tube=2]*[Repetition=2]	-.3333 <sup>a</sup>	.09717	1	.001	-.5238	-.1429
	[Color of Tube=2]*[Repetition=3]	-.3550 <sup>a</sup>	.12432	1	.004	-.5987	-.1113

	[Color of Tube=3]*[Repetition=1]	.0033	.11381	1	.977	-.2197	.2264
	[Color of Tube=3]*[Repetition=2]	-.0392	.08857	1	.658	-.2128	.1344
	[Color of Tube=3]*[Repetition=3]	-.0942	.12855	1	.464	-.3461	.1578
[Color of Tube=2]*[Repetition=1]	[Color of Tube=1]*[Repetition=1]	.2025 <sup>a</sup>	.04008	1	.000	.1239	.2811
	[Color of Tube=1]*[Repetition=2]	.0025	.12706	1	.984	-.2465	.2515
	[Color of Tube=1]*[Repetition=3]	.0492	.07219	1	.496	-.0923	.1907
	[Color of Tube=2]*[Repetition=2]	-.2842 <sup>a</sup>	.04324	1	.000	-.3689	-.1994
	[Color of Tube=2]*[Repetition=3]	-.3058 <sup>a</sup>	.07013	1	.000	-.4433	-.1684
	[Color of Tube=3]*[Repetition=1]	.0525	.09948	1	.598	-.1425	.2475
	[Color of Tube=3]*[Repetition=2]	.0100	.09763	1	.918	-.1814	.2014
	[Color of Tube=3]*[Repetition=3]	-.0450	.12019	1	.708	-.2806	.1906
[Color of Tube=2]*[Repetition=2]	[Color of Tube=1]*[Repetition=1]	.4867 <sup>a</sup>	.07612	1	.000	.3375	.6359
	[Color of Tube=1]*[Repetition=2]	.2867 <sup>a</sup>	.14042	1	.041	.0114	.5619
	[Color of Tube=1]*[Repetition=3]	.3333 <sup>a</sup>	.09717	1	.001	.1429	.5238
	[Color of Tube=2]*[Repetition=1]	.2842 <sup>a</sup>	.04324	1	.000	.1994	.3689
	[Color of Tube=2]*[Repetition=3]	-.0217	.06118	1	.723	-.1416	.0982



	[Color of Tube=3]*[Repetition=1]	.3367 <sup>a</sup>	.10734	1	.002	.1263	.5470
	[Color of Tube=3]*[Repetition=2]	.2942 <sup>a</sup>	.12913	1	.023	.0411	.5473
	[Color of Tube=3]*[Repetition=3]	.2392 <sup>a</sup>	.11778	1	.042	.0083	.4700
[Color of Tube=2]*[Repetition=3]	[Color of Tube=1]*[Repetition=1]	.5083 <sup>a</sup>	.09899	1	.000	.3143	.7024
	[Color of Tube=1]*[Repetition=2]	.3083	.18491	1	.095	-.0541	.6707
	[Color of Tube=1]*[Repetition=3]	.3550 <sup>a</sup>	.12432	1	.004	.1113	.5987
	[Color of Tube=2]*[Repetition=1]	.3058 <sup>a</sup>	.07013	1	.000	.1684	.4433
	[Color of Tube=2]*[Repetition=2]	.0217	.06118	1	.723	-.0982	.1416
	[Color of Tube=3]*[Repetition=1]	.3583 <sup>a</sup>	.12179	1	.003	.1196	.5970
	[Color of Tube=3]*[Repetition=2]	.3158 <sup>a</sup>	.12354	1	.011	.0737	.5580
	[Color of Tube=3]*[Repetition=3]	.2608 <sup>a</sup>	.09757	1	.008	.0696	.4521
[Color of Tube=3]*[Repetition=1]	[Color of Tube=1]*[Repetition=1]	.1500	.09595	1	.118	-.0380	.3380
	[Color of Tube=1]*[Repetition=2]	-.0500	.13122	1	.703	-.3072	.2072
	[Color of Tube=1]*[Repetition=3]	-.0033	.11381	1	.977	-.2264	.2197
	[Color of Tube=2]*[Repetition=1]	-.0525	.09948	1	.598	-.2475	.1425
	[Color of Tube=2]*[Repetition=2]	-.3367 <sup>a</sup>	.10734	1	.002	-.5470	-.1263

	[Color of Tube=2]*[Repetition=3]	-.3583 <sup>a</sup>	.12179	1	.003	-.5970	-.1196
	[Color of Tube=3]*[Repetition=2]	-.0425	.08638	1	.623	-.2118	.1268
	[Color of Tube=3]*[Repetition=3]	-.0975	.09546	1	.307	-.2846	.0896
[Color of Tube=3]*[Repetition=2]	[Color of Tube=1]*[Repetition=1]	.1925 <sup>a</sup>	.08646	1	.026	.0230	.3620
	[Color of Tube=1]*[Repetition=2]	-.0075	.15961	1	.963	-.3203	.3053
	[Color of Tube=1]*[Repetition=3]	.0392	.08857	1	.658	-.1344	.2128
	[Color of Tube=2]*[Repetition=1]	-.0100	.09763	1	.918	-.2014	.1814
	[Color of Tube=2]*[Repetition=2]	-.2942 <sup>a</sup>	.12913	1	.023	-.5473	-.0411
	[Color of Tube=2]*[Repetition=3]	-.3158 <sup>a</sup>	.12354	1	.011	-.5580	-.0737
	[Color of Tube=3]*[Repetition=1]	.0425	.08638	1	.623	-.1268	.2118
	[Color of Tube=3]*[Repetition=3]	-.0550	.10476	1	.600	-.2603	.1503
[Color of Tube=3]*[Repetition=3]	[Color of Tube=1]*[Repetition=1]	.2475	.12696	1	.051	-.0013	.4963
	[Color of Tube=1]*[Repetition=2]	.0475	.19016	1	.803	-.3252	.4202
	[Color of Tube=1]*[Repetition=3]	.0942	.12855	1	.464	-.1578	.3461
	[Color of Tube=2]*[Repetition=1]	.0450	.12019	1	.708	-.1906	.2806
	[Color of Tube=2]*[Repetition=2]	-.2392 <sup>a</sup>	.11778	1	.042	-.4700	-.0083

	[Color of Tube=2]*[Repetition=3]	-.2608 <sup>a</sup>	.09757	1	.008	-.4521	-.0696
	[Color of Tube=3]*[Repetition=1]	.0975	.09546	1	.307	-.0896	.2846
	[Color of Tube=3]*[Repetition=2]	.0550	.10476	1	.600	-.1503	.2603

Response Time: Estimated Marginal Means 1: Color of Tube

Color of Tube	Mean	Std. Error	95% Wald Confidence Interval	
			Lower	Upper
Pink	10.06	2.115	5.91	14.20
White	6.92	1.151	4.66	9.17
Blue	9.56	1.183	7.24	11.87

Response Time: Pairwise Comparisons: Color of Tube

(I) Color of Tube	(J) Color of Tube	Mean Difference (I-J)	Std. Error	df	Sig.	95% Wald Confidence Interval for Difference	
						Lower	Upper
Pink	White	3.14 <sup>a</sup>	1.373	1	.022	.45	5.83
	Blue	.50	1.189	1	.674	-1.83	2.83
White	Pink	-3.14 <sup>a</sup>	1.373	1	.022	-5.83	-.45
	Blue	-2.64 <sup>a</sup>	.564	1	.000	-3.75	-1.53
Blue	Pink	-.50	1.189	1	.674	-2.83	1.83
	White	2.64 <sup>a</sup>	.564	1	.000	1.53	3.75

Pairwise comparisons of estimated marginal means based on the original scale of dependent variable:  
Response Time

a. The mean difference is significant at the .05 level.

Response Time: Estimated Marginal Means 2: Repetition

Repetition	Mean	Std. Error	95% Wald Confidence Interval	
			Lower	Upper
Repetition 1	10.67	1.341	8.04	13.30
Repetition 2	8.00	1.551	4.96	11.04
Repetition 3	7.86	1.467	4.98	10.74

Response Time: Pairwise Comparisons: Repetition

(I) Repetition	(J) Repetition	Mean Difference (I-J)	Std. Error	df	Sig.	95% Wald Confidence Interval for Difference	
						Lower	Upper
Repetition 1	Repetition 2	2.67 <sup>a</sup>	.802	1	.001	1.09	4.24
	Repetition 3	2.81 <sup>a</sup>	.638	1	.000	1.56	4.06
Repetition 2	Repetition 1	-2.67 <sup>a</sup>	.802	1	.001	-4.24	-1.09
	Repetition 3	.14	.234	1	.552	-.32	.60
Repetition 3	Repetition 1	-2.81 <sup>a</sup>	.638	1	.000	-4.06	-1.56
	Repetition 2	-.14	.234	1	.552	-.60	.32

Response Time: Estimated Marginal Means 3: Color of Tube\* Repetition

Color of Tube	Repetition	Mean	Std. Error	95% Wald Confidence Interval	
				Lower	Upper
Pink	Repetition 1	11.25	2.663	6.03	16.47
	Repetition 2	9.17	1.809	5.62	12.71
	Repetition 3	9.75	2.207	5.42	14.08
White	Repetition 1	8.83	1.690	5.52	12.15
	Repetition 2	6.33	1.084	4.21	8.46
	Repetition 3	5.58	.968	3.69	7.48

Blue	Repetition 1	11.92	1.277	9.41	14.42
	Repetition 2	8.50	1.878	4.82	12.18
	Repetition 3	8.25	1.674	4.97	11.53

Response Time: Pairwise Comparisons: Color of Tube \* Repetition

(I) Color of Tube*Repetition	(J) Color of Tube*Repetition	Mean Difference (I-J)	Std. Error	df	Sig.	95% Wald Confidence Interval for Difference	
						Lower	Upper
[Color of Tube=1]*[Repetition=1]	[Color of Tube=1]*[Repetition=2]	2.08	1.831	1	.255	-1.51	5.67
	[Color of Tube=1]*[Repetition=3]	1.50	1.034	1	.147	-.53	3.53
	[Color of Tube=2]*[Repetition=1]	2.42	2.518	1	.337	-2.52	7.35
	[Color of Tube=2]*[Repetition=2]	4.92 <sup>a</sup>	1.916	1	.010	1.16	8.67
	[Color of Tube=2]*[Repetition=3]	5.67 <sup>a</sup>	1.824	1	.002	2.09	9.24
	[Color of Tube=3]*[Repetition=1]	-.67	2.608	1	.798	-5.78	4.44
	[Color of Tube=3]*[Repetition=2]	2.75	1.437	1	.056	-.07	5.57
	[Color of Tube=3]*[Repetition=3]	3.00	2.291	1	.190	-1.49	7.49
[Color of Tube=1]*[Repetition=2]	[Color of Tube=1]*[Repetition=1]	-2.08	1.831	1	.255	-5.67	1.51
	[Color of Tube=1]*[Repetition=3]	-.58	1.023	1	.569	-2.59	1.42
	[Color of Tube=2]*[Repetition=1]	.33	1.200	1	.781	-2.02	2.69

	[Color of Tube=2]*[Repetition=2]	2.83 <sup>a</sup>	1.058	1	.007	.76	4.91
	[Color of Tube=2]*[Repetition=3]	3.58 <sup>a</sup>	1.096	1	.001	1.44	5.73
	[Color of Tube=3]*[Repetition=1]	-2.75	2.201	1	.211	-7.06	1.56
	[Color of Tube=3]*[Repetition=2]	.67	.597	1	.264	-.50	1.84
	[Color of Tube=3]*[Repetition=3]	.92	.916	1	.317	-.88	2.71
[Color of Tube=1]*[Repetition=3]	[Color of Tube=1]*[Repetition=1]	-1.50	1.034	1	.147	-3.53	.53
	[Color of Tube=1]*[Repetition=2]	.58	1.023	1	.569	-1.42	2.59
	[Color of Tube=2]*[Repetition=1]	.92	2.029	1	.651	-3.06	4.89
	[Color of Tube=2]*[Repetition=2]	3.42 <sup>a</sup>	1.525	1	.025	.43	6.41
	[Color of Tube=2]*[Repetition=3]	4.17 <sup>a</sup>	1.373	1	.002	1.48	6.86
	[Color of Tube=3]*[Repetition=1]	-2.17	2.323	1	.351	-6.72	2.39
	[Color of Tube=3]*[Repetition=2]	1.25	.903	1	.166	-.52	3.02
	[Color of Tube=3]*[Repetition=3]	1.50	1.764	1	.395	-1.96	4.96
[Color of Tube=2]*[Repetition=1]	[Color of Tube=1]*[Repetition=1]	-2.42	2.518	1	.337	-7.35	2.52
	[Color of Tube=1]*[Repetition=2]	-.33	1.200	1	.781	-2.69	2.02
	[Color of Tube=1]*[Repetition=3]	-.92	2.029	1	.651	-4.89	3.06

	[Color of Tube=2]*[Repetition=2]	2.50 <sup>a</sup>	1.041	1	.016	.46	4.54
	[Color of Tube=2]*[Repetition=3]	3.25 <sup>a</sup>	1.327	1	.014	.65	5.85
	[Color of Tube=3]*[Repetition=1]	-3.08	2.326	1	.185	-7.64	1.47
	[Color of Tube=3]*[Repetition=2]	.33	1.251	1	.790	-2.12	2.79
	[Color of Tube=3]*[Repetition=3]	.58	.321	1	.069	-.05	1.21
[Color of Tube=2]*[Repetition=2]	[Color of Tube=1]*[Repetition=1]	-4.92 <sup>a</sup>	1.916	1	.010	-8.67	-1.16
	[Color of Tube=1]*[Repetition=2]	-2.83 <sup>a</sup>	1.058	1	.007	-4.91	-.76
	[Color of Tube=1]*[Repetition=3]	-3.42 <sup>a</sup>	1.525	1	.025	-6.41	-.43
	[Color of Tube=2]*[Repetition=1]	-2.50 <sup>a</sup>	1.041	1	.016	-4.54	-.46
	[Color of Tube=2]*[Repetition=3]	.75	.386	1	.052	-.01	1.51
	[Color of Tube=3]*[Repetition=1]	-5.58 <sup>a</sup>	1.789	1	.002	-9.09	-2.08
	[Color of Tube=3]*[Repetition=2]	-2.17 <sup>a</sup>	.903	1	.016	-3.94	-.40
	[Color of Tube=3]*[Repetition=3]	-1.92 <sup>a</sup>	.939	1	.041	-3.76	-.08
[Color of Tube=2]*[Repetition=3]	[Color of Tube=1]*[Repetition=1]	-5.67 <sup>a</sup>	1.824	1	.002	-9.24	-2.09
	[Color of Tube=1]*[Repetition=2]	-3.58 <sup>a</sup>	1.096	1	.001	-5.73	-1.44
	[Color of Tube=1]*[Repetition=3]	-4.17 <sup>a</sup>	1.373	1	.002	-6.86	-1.48

	[Color of Tube=2]*[Repetition=1]	-3.25 <sup>a</sup>	1.327	1	.014	-5.85	-.65
	[Color of Tube=2]*[Repetition=2]	-.75	.386	1	.052	-1.51	.01
	[Color of Tube=3]*[Repetition=1]	-6.33 <sup>a</sup>	1.669	1	.000	-9.61	-3.06
	[Color of Tube=3]*[Repetition=2]	-2.92 <sup>a</sup>	.968	1	.003	-4.81	-1.02
	[Color of Tube=3]*[Repetition=3]	-2.67 <sup>a</sup>	1.206	1	.027	-5.03	-.30
[Color of Tube=3]*[Repetition=1]	[Color of Tube=1]*[Repetition=1]	.67	2.608	1	.798	-4.44	5.78
	[Color of Tube=1]*[Repetition=2]	2.75	2.201	1	.211	-1.56	7.06
	[Color of Tube=1]*[Repetition=3]	2.17	2.323	1	.351	-2.39	6.72
	[Color of Tube=2]*[Repetition=1]	3.08	2.326	1	.185	-1.47	7.64
	[Color of Tube=2]*[Repetition=2]	5.58 <sup>a</sup>	1.789	1	.002	2.08	9.09
	[Color of Tube=2]*[Repetition=3]	6.33 <sup>a</sup>	1.669	1	.000	3.06	9.61
	[Color of Tube=3]*[Repetition=2]	3.42	2.326	1	.142	-1.14	7.97
	[Color of Tube=3]*[Repetition=3]	3.67	2.201	1	.096	-.65	7.98
[Color of Tube=3]*[Repetition=2]	[Color of Tube=1]*[Repetition=1]	-2.75	1.437	1	.056	-5.57	.07
	[Color of Tube=1]*[Repetition=2]	-.67	.597	1	.264	-1.84	.50
	[Color of Tube=1]*[Repetition=3]	-1.25	.903	1	.166	-3.02	.52



	[Color of Tube=2]*[Repetition=1]	-.33	1.251	1	.790	-2.79	2.12
	[Color of Tube=2]*[Repetition=2]	2.17 <sup>a</sup>	.903	1	.016	.40	3.94
	[Color of Tube=2]*[Repetition=3]	2.92 <sup>a</sup>	.968	1	.003	1.02	4.81
	[Color of Tube=3]*[Repetition=1]	-3.42	2.326	1	.142	-7.97	1.14
	[Color of Tube=3]*[Repetition=3]	.25	1.019	1	.806	-1.75	2.25
[Color of Tube=3]*[Repetition=3]	[Color of Tube=1]*[Repetition=1]	-3.00	2.291	1	.190	-7.49	1.49
	[Color of Tube=1]*[Repetition=2]	-.92	.916	1	.317	-2.71	.88
	[Color of Tube=1]*[Repetition=3]	-1.50	1.764	1	.395	-4.96	1.96
	[Color of Tube=2]*[Repetition=1]	-.58	.321	1	.069	-1.21	.05
	[Color of Tube=2]*[Repetition=2]	1.92 <sup>a</sup>	.939	1	.041	.08	3.76
	[Color of Tube=2]*[Repetition=3]	2.67 <sup>a</sup>	1.206	1	.027	.30	5.03
	[Color of Tube=3]*[Repetition=1]	-3.67	2.201	1	.096	-7.98	.65
	[Color of Tube=3]*[Repetition=2]	-.25	1.019	1	.806	-2.25	1.75