

5-2019

# Effects of Critical Reflection on University Students' Cognitive Achievement in Agricultural Mechanization

Patterson P. Hilaire

*University of Arkansas, Fayetteville*

Follow this and additional works at: <https://scholarworks.uark.edu/etd>

 Part of the [Agricultural Education Commons](#), [Cognition and Perception Commons](#), [Cognitive Psychology Commons](#), and the [Educational Assessment, Evaluation, and Research Commons](#)

---

## Recommended Citation

Hilaire, Patterson P., "Effects of Critical Reflection on University Students' Cognitive Achievement in Agricultural Mechanization" (2019). *Theses and Dissertations*. 3253.

<https://scholarworks.uark.edu/etd/3253>

This Thesis is brought to you for free and open access by ScholarWorks@UARK. It has been accepted for inclusion in Theses and Dissertations by an authorized administrator of ScholarWorks@UARK. For more information, please contact [ccmiddle@uark.edu](mailto:ccmiddle@uark.edu).

Effects of Critical Reflection on University Students' Cognitive  
Achievement in Agricultural Mechanization

A thesis submitted in partial fulfillment  
of the requirements for degree of  
Master of Science in Agricultural and Extension Education

by

Patterson Hilaire  
University of Arkansas  
Bachelor of Science in Agricultural Education, Communication, and Technology, 2016

May 2019  
University of Arkansas

This thesis is approved for recommendation to the Graduate Council.

---

Donald M. Johnson, Ph.D.  
Thesis Director

---

Donna L. Graham, Ph.D.  
Committee Member

---

Vinson R. Carter, Ph.D.  
Committee Member

---

George Wm. Wardlow, Ph.D.  
Committee Member

## Abstract

Experiential learning continues to play a vital role in agricultural education and mechanization laboratories (Shoulders & Myers, 2013). An essential component of experiential learning is critical reflection. Critical reflection helps students process and construct meaning from laboratory experiences. A study conducted by Shoulders and Myers (2013) revealed that only 15.4% of the agricultural educators the researchers interviewed incorporated reflective practices laboratory experiences. The purpose of this study was to evaluate the effect of critical reflection on students' achievement following five agricultural mechanization laboratory activities. The results from this study revealed that critical reflection had a consistently positive effect on immediate cognitive achievement but not delayed cognitive achievement among the participants of this study; however, the results for delayed cognitive achievement were mixed. Recommendations include further research into effective practices for helping students increase long term learning from laboratory instructions.

## Acknowledgments

I would like to express deep gratitude towards Dr. Johnson for all the support he has given me over the years. Dr. Johnson has been an extremely patient and encouraging advisor. There were days I would just barge into Dr. Johnson office with some novel idea (or some idea I thought was novel), and Dr. Johnson would patiently advise and steer me in the right direction, no matter how ridiculous the idea. I would also like to thank him for teaching me statistics and how to write scientifically. He has challenged me to be innovative, and his words of encouragement and wisdom I will never forget.

I would like to thank all of my thesis committee members for all of their input and advice regarding my thesis. I would also like to thank Brad Borges for allowing me to use Small Power Units and Turf Grass Equipment to collect data.

I would also like to thank my parents for all the support they have given me through my academic career. I want to thank them for paying two-thirds of my undergraduate out of their own pockets. I would also like to thank them for supporting me through my graduate education as well. Without my parents support, I would not have attended graduate school or finish a thesis. I would like to thank my three sisters for the emotional support they gave me during the time I was completing this project. I would like to especially thank Paula Hilaire for the encouraging words, gifts and financial support during my graduate education.

I would like to thank the Crothers family who paid the other 60% of my undergraduate education. They have also been an immense encouragement through my educational career. I would also like to thank Dr. Bronson Stillwell, my personal therapist, and mentor. He provided a timeline to finish my thesis, and have sponsored several of my study-abroad trips as a graduate student.

## Dedication

I would like to dedicate this thesis to my mother who only had a third-grade level education, but ensured her four children went to college, and to my father who wanted to attend college but ran into financial difficulty.

## Table of Contents

### Chapter

<b>I.</b>	<b>Introduction</b> .....	1
	Need for Study .....	2
	Statement of the Problem.....	3
	Purpose of the Study.....	4
	Assumptions .....	5
<b>II.</b>	<b>Theoretical Framework</b> .....	7
	Conceptual Framework.....	7
	Development of Experiential Learning Theory.....	9
	Critical Reflection.....	13
	DEAL Reflection Method.....	15
	Theoretical Framework.....	15
<b>III.</b>	<b>Methodology</b> .....	20
	Research Design.....	21
	Internal Validity of Experiments.....	22
	Population.....	24
	Instrument.....	25
	Treatment.....	27
	Data Collection Procedures.....	28
	Statistical Analysis.....	31
<b>IV.</b>	<b>Results</b> .....	33
	Summary of Methodology.....	34
	Experiment One.....	35
	Experiment Two.....	36
	Experiment Three.....	37
	Experiment Four.....	39
	Experiment Five.....	40
<b>IV.</b>	<b>Summary, Conclusions, Implications, and Recommendation</b> .....	44
	Conclusions.....	44
	Implications for Practice.....	47
	Implications for Further Research.....	48
	Summary.....	49

**References**.....51

**Appendices**.....56

## Chapter I

### Introduction

Over the years, laboratory experiences have played a critical role in secondary and postsecondary education (Forcino, 2013; Shinn, 1987; Hofstein, 2004; Johnson & Schumacher, 1989). Shinn (1987) commenting on the importance of laboratory experiences noted that one-third of course instructional time is allocated to laboratory activities. The National Research Council (2009) expresses similar sentiments by stating that high school science students spend at least one class period a week participating in laboratory experiences. With the amount of time allocated to laboratory activities, laboratories have secured a prominent place in education, and today, all across the nation, high schools and universities are utilizing laboratories to provide students with the opportunity to develop scientific skills and apply and understand the theory learned in lectures.

Laboratories, however, did not always hold such a prominent place in education. Historically, scholars have agreed that laboratory instruction was not adopted into higher education until the 1800s when American institutions decided to replicate a German model of research and training (Rudolph, 2005). Before that time, higher learning intuitions were heavily reliant on rote memorization and classical styles of education (National Research Council, 2009). Nevertheless, in the latter part of the 19<sup>th</sup> century, universities became more interested in the methods of science, and with several universities already adopting the German model of advanced research, other institutions such as high schools followed suit in adopting various scientific methods that implemented laboratory instruction (Rudolph, 2005).

By the turn of the 19<sup>th</sup> century, laboratory instruction became common, and prominent figures in the progressive education movement like John Dewey became major proponents of the



nature and pedagogy of the scientific method and laboratory instruction (Hofstein & Lunetta, 1982). Such interest in methods of science and laboratories continued throughout the 20<sup>th</sup> century; especially during the Second World War and the Cold War (Hofstein & Lunetta, 1982; Rudolph, 2005).

Fast forward to the 21<sup>st</sup> century, there continues to be an interest in laboratory instruction. In the discipline of agricultural mechanics education, laboratories are utilized to provide students with experience in obtaining skills that reflect the agricultural industry (Ewing, 2005). Warner, Arnold, Jones, and Myers (2006) noted that agriscience laboratories allow students to process complex and abstract scientific concepts by engaging students with meaningful laboratory experiences or materials. Students have the chance to directly interact and apply what they have learned in a lecture by simply participating in laboratory activities.

The time spent in laboratories is also indicative of the importance of agricultural laboratories. Johnson and Schumacher (1989) indicated that the majority of the instructional time in agricultural mechanics education courses is spent in agricultural mechanization laboratories. Shinn (1987) also made a similar observation and noted that one-third to two-thirds of instructional time in agricultural courses is usually devoted to agricultural mechanics instruction (as cited in Johnson, Schumacher, & Stewart, 1990).

### **Need for the Study**

Considering the significance of agricultural mechanics laboratories in educational programs today, it is important that laboratories offer quality educational experiences, managed efficiently and are grounded in relevant pedagogical practices (Ewing, 2005; Johnson & Schumacher, 1989; Schlautman & Silletto, 1992; Shinn, 1987; Shoulders & Myers, 2013).

Students will learn best when laboratories are well organized and can facilitate the transfer of knowledge.

Experiential learning theories have long been considered as a paramount and effective pedagogical practice that can be applied to agricultural laboratories in order to facilitate and transfer learning (Baker, Robinson, & Kolb, 2012; Shoulders & Myers, 2013; Shoulders, Wyatt, & Johnson, 2014). Abdulwahed and Nagy (2009), have also suggested that implementing a proven pedagogical theory known as Kolb's experiential learning theory can help improve learning outcomes in laboratories.

In addition, the National Research Council has also challenged agricultural educators by indicating that traditional approaches of lecture in the discipline of agriculture may not be as effective as “tutorials, laboratories, field-based learning experiences and problem-based learning” (National Research Council, 2009, p. 35). The research agenda of the American Association for Agricultural Education (2016) has also challenged agricultural educators to implement problem-based and student-centered learning into their instructional practice (Roberts, Harder, & Brashears, 2016). To put it simply, the National Research Council and the American Association for Agricultural Education are challenging educators to adopt teaching practices that will actively engage students in learning by doing.

### **Statement of the Problem**

With such recommendations, it is imperative that educators take the responsibility to address the importance of experiential learning and effective laboratory experiences in agriculture. Roberts (2006) and Mazurkeqicz, Harder, and Roberts (2012) have echoed similar sentiments and have noted that experiential learning merits more attention in the discipline of agricultural education in order to ensure effective teaching and learning. However, limited

consideration has been given to its importance in “the permanent agricultural education literature base” (Baker, Robinson, & Kolb, 2012, p. 1). Shoulders and Myers (2013) have also pointed out that even though some literature exists regarding experiential learning and agricultural education, agricultural educators have “not yet mastered” the theory of experiential learning (p.104).

In addition to that, researchers have suggested that a holistic approach that takes into account all the essential components of experiential learning in laboratory learning is needed (Abdulwahed & Nagy, 2009; Shoulders & Myers, 2013). A study conducted by Shoulders and Myers (2013) revealed that only 15.4% of the agricultural educators the researchers interviewed employed reflective practices, a critical component of experiential learning, into their laboratories. This study will attempt to address such challenges by adding to the existing literature on experiential learning in agricultural mechanization laboratories.

### **Purpose of the Study**

The purpose of this study was to evaluate the effect of critical reflection on students’ achievement following an agricultural mechanization laboratory activity. The primary research question was: What effect does critical reflection have on students’ laboratory performance compared to the laboratory performance of students who do not critically reflect? The specific research objectives were to:

1. Determine if there is a difference in immediate cognitive achievement in selected agricultural mechanization topics by the main effect of reflection (no reflection, individual or group reflection).
2. Determine if there is a difference in delayed cognitive achievement in selected agricultural mechanization topics by main effect of reflection (no reflection, individual or group reflection).

This study was conducted in two separate agricultural mechanization courses at the University of Arkansas Fayetteville, the first being Electricity in Agriculture (AGME 3173) and the second being Small Power Units/Turf Equipment Laboratory (AGME 3101L). The accessible population was sixty students ( $N = 60$ ) enrolled in the courses listed above.

### **Limitations**

Because an entire population was selected for this study, the results may not be generalizable to other groups. Moreover, students were initially randomly assigned to either a control group (no reflection) or one of two experimental groups (individual or group reflection). Once students were assigned to one of these groups, they remained in that group for the remainder of the study. The number of treatments employed during the duration of this study may also be another limiting factor to this study.

### **Terms and Definitions**

The following terminologies were used throughout this study:

1. Cognitive Achievement: a measure of student's performance based on scores received on posttests (Newsome, 2004 ).
2. Experiential Learning (EL): acquiring knowledge through "doing" or interacting with external subjects in order to understand or comprehend a given subject (Koch, 2010).
3. Delayed Cognitive Achievement: a measure of student's performance on posttest two weeks after the initial interaction with laboratory activity (Newsome, 2004 ).

### **Assumptions**

As this study was conducted, the following assumptions were made:

1. The instruments utilized were valid and provided reliable questions that measured student's cognitive achievement.

2. Those who participated in this study were honest when responding to posttest and delayed posttests.
3. The participants who underwent the study had little to no prior knowledge of the laboratory activities in Agricultural Electricity and Small Power Units.
4. The treatments were sufficiently different to produce or result in difference on the immediate and delayed posttests.
5. No diffusion of treatments occurred between students in the three groups.

## Chapter II

### Theoretical Framework

The focal point of this chapter will be to provide a theoretical framework and a review of literature that currently exist on critical reflection, experiential learning and cognitive learning theories. A large portion of this chapter is devoted to understanding reflection and its relevance to experiential learning.

#### **Conceptual Framework**

Experiential learning continues to be a hallmark of agricultural education. Historically, scholars have argued that agricultural education in the United States of America has always had experiential learning as its pedagogical foundation (Baker, Robinson, & Kolb, 2012; McKim, Greenhaw, Carla, Redwine, & McCubbins, 2017). Such a statement can be supported by simply examining the different legislation that has influenced the establishment of agricultural education in the United States.

The Morrill Act of 1862 will be considered first. The establishment of formal agricultural education at the collegiate level can be traced back to the establishment of land-grant universities through the passage of the Morrill Act of 1862. Section four of the Morrill Act states,

To teach such branches of learning as are related to agriculture and the mechanic arts, in such as the legislatures of the States may respectively prescribe, in order to promote the liberal and practical education of the industrial classes in the several pursuits and professions in life (as cited in Flower & Haddad, 2014, p. 198).

The Morrill Act of 1862 called for instruction in agriculture to be taught as an applied subject that would aid in educating the American populace about the science and the application of agriculture. It is important to note that even though the Morrill Act was one of the blueprints for agricultural education in America, non- formal and formal agricultural educational initiatives

were undertaken years before the Morrill Act was ever established; such initiatives came in the form of agricultural societies, fairs and private colleges (True, 1929).

A second influential legislation was the Smith-Lever Act of 1914 that established cooperative extension services. The Smith-Lever Act ensured education in agriculture remained experiential in nature. Agricultural extension education services were established to promote the dissemination of practical scientific principles of agriculture (Hillison, 1996). Seaman Knapp, a pioneer in agricultural extension education ingrained the philosophy of “learning by doing” into extension education (Knobloch, 2003). Knapp made a concerted effort in his day to challenge agricultural educators to provide instruction through the practical means of on-farm demonstrations and community-based education (Surls, 2014). Seaman Knapp once said, “what a man hears, he may doubt; what he sees, he may also doubt, but what he does, he cannot doubt” (as cited in Knobloch, 2003, p.28). The fundamental legislative and philosophical foundation of agricultural extension education provides unambiguous proof that learning by experience was to play an integral part in the life and application of extension education.

The Smith Hughes Act (Public Law No.347, 64<sup>th</sup> Congress 703) provides further proof of the experiential nature regarding the founding of education in agriculture. The Smith Hughes Act of 1917 established vocational education at the secondary level, and at its pedagogical underpinning was applied and experiential (Newsome, 2004). The Smith Hughes Act ensured industrial education was promoted at the high-school level, but it also ensured agricultural educators at the secondary level were equipped to train students in learning how to perform a skill or trade (Graham & Craig, 2018; Newsome, 2004; Shelley-Tolbert, Conroy, & Dailey, 2000). A central tenant of the Smith Hughes Act would be the Supervised Agriculture Experience (SAE) program. Section ten of the Smith Hughes Act of 1917 defines SAE as,

supervised practice in agriculture, either on a farm provided for by the school or other farms, for at least six months per year (Newsome, 2004). Fundamentally, the Smith Hughes Act encouraged agricultural educators to provide a practical and applied learning experience in secondary education. Overall, practical and applied instruction are the universal language used in the in the Morrill Act of 1862, Smith-Lever Act of 1914 and the Smith Hughes Act of 1917. This legislation has played a crucial role in the development of the pedagogy that is seen in the discipline of agriculture today.

### **Development of Experiential Learning Theory**

Experiential learning has and continues to occupy a significant role in agricultural education. Experiential learning (EL) can be defined as an instructional or educational theory which asserts learning occurs through the interaction of discovery and experience (Deslauriers, Rudd, Westfall-Rud, & Splan, 2016; Shoulders, Wyatt, & Johnson, 2014). The underlying principle of EL is that learning occurs from reflecting on a given experience or observation (Cano, 2005). It is important to note that EL is much more than simply “doing,” rather; it requires a continuous reflection on the “doing” or experience. In traditional methods of learning, the teacher or educator is typically seen as the expositor transferring knowledge to their pupils. However, in experiential learning, the teacher takes the role of a facilitator who is constantly engaging and guiding students in learning (Knobloch, 2003). This results in students taking a more active role in learning by allowing students to utilize experiences and skills to analyze, interpret and self-reflect on different information which results in students grasping new concepts. The fundamental components of experiential learning as described by Kolb (1984) are perception, involvement, cognition, and behavior.



Many have attributed the development of experiential learning, as it is known today, to the work of John Dewey in (1938) (Baker, Robinson, & Kolb, 2012; Deslauriers, Rudd, Westfall-Rud, & Splan, 2016; Kayes, 2002; Knobloch, 2003; Mowen & Harder, 2005; Marlow & McLain, 2011; Roberts, 2006; Shoulders, Wyatt, & Johnson, 2014). Dewey (1938) posited that learning is the result of students' interaction with their environment, which he defines as an experience. Such experience is affected by factors that are internal to the student such as the students "attitudes, beliefs, habits, prior knowledge, and emotions" (Carver & Enfield, 2006, p. 56).

The second proposition of Dewey is that every experience continually builds on past experiences, and these past experiences influence the quality of future experiences (Dewey, 1938). Dewey defines both of these phenomena as the principle of interaction and continuity, and it is these two principles that govern the quality of an educational experience (Carver & Enfield, 2006). Dewey believed no learning can occur unless an individual is changed by their experience (Deslauriers, Rudd, Westfall-Rudd, & Splan, 2016). To put it simply, Dewey's educational ideology is that students acquire knowledge through physically interacting with concepts or activities, and when students interact with a given concept or activity, they begin to formulate attitudes, beliefs, habits, and emotion toward the activity. In addition to that, prior interactions contribute to the forming of the internal factors of attitudes beliefs, habits and emotion.

It is imperative to note at this point that Dewey never claimed that traditional forms of education do not contain experience, rather, he is saying that traditional education does not take a holistic approach taking into account individual backgrounds and their former interaction with a given subject matter or activity. As Dewey (1938) explained:

It is a great mistake to suppose, even tacitly, that the traditional schoolroom was not a place in which pupils had experiences. Yet this is tacitly assumed when progressive

education as a plan of learning by experience is placed in sharp opposition to the old. The proper line of attack is that the experiences, which were had, by pupils and teachers alike, were largely of a wrong kind. How many students, for example, were rendered callous to ideas, and how many lost the impetus to learn because of the Way in which learning was experienced by them? How many acquired special skills by means of automatic drill so that their power of judgment and capacity to act intelligently in new situations was limited? How many came to associate the learning process with ennui and boredom? (p. 9).

### **Kolb's Experiential Learning Model**

Following Dewey, there have been several other educators and philosophers that have written about experiential learning. For instance, Jean Piaget, Lev Vygotsky, Peter Jarvis, Kurt Hahn, Paulo Freire, and David Kolb are all known for making historical landmarks regarding experiential learning (Marlow & McLain, 2011). However, Kolb (1984) is best known for his writings on learning by experience, and it said that he has produced the most efficient and logical framework that explains experiential learning (Abdulwahed & Nagy, 2009; Cano, 2005; Roberts, 2006; Salavastru, 2014). In addition to Kolb's model being regarded as the most comprehensive model of learning by experience, it has been the most prominent in the agricultural education literature (Roberts G. T., 2006).

Kolb (1984) experiential learning model (KELM) posits that learners go through four stages which he describes as, Concrete Experience (CE), Reflective Observation (RO), Abstract Conceptualization (AC), and Active Experimentation (AE); learning can be activated at any one of the stages and does not have to occur in order. Kolb asserted that Concrete Experience is when learners are directly involved or introduced to an activity or subject matter. At this stage, learners are said to be grasping information through the process of apprehension, and students use their senses of hearing, touch or sight. The stage that follows is reflective observation. When learners move to this stage, they begin to think and reflect on the previous experience they just had. At this stage, learners transform their experience by internally processing and cognitively breaking

down the previous experience. The Abstract Conceptualization stage follows where students grasp the experience through comprehension by turning the previous experience into theories, generalizations, and hypotheses. The last stage is Active Experimentation, and this is where learners apply the knowledge they gained from their interaction with the subject matter or activity. Figure 1 below provides a graphic that summarizes Kolb's model of experiential learning.

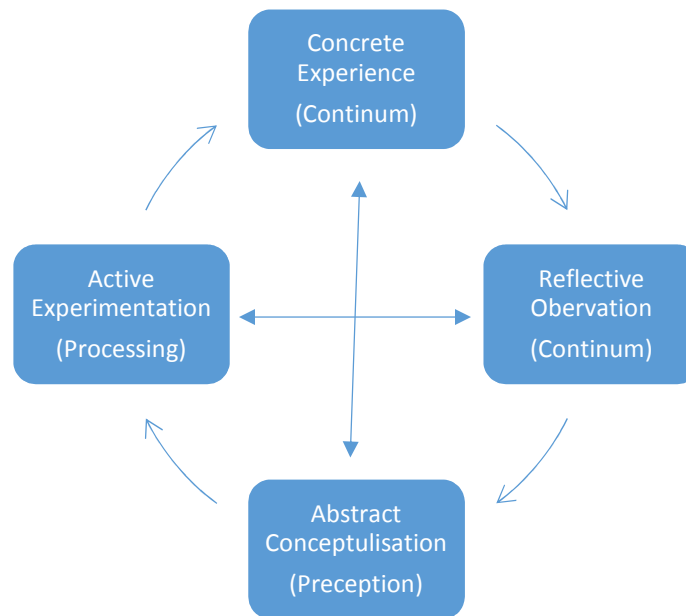

Figure 1. (Kolb, 1984) Kolb's Model of Experiential Learning

Abdulwahed and Nagy (2009) posited “the optimal learning takes place when learners have an adequate balance of these four stages during their learning experience” (Abdulwahed & Nagy, 2009, p. 284). Baker et al. (2012) also echoed similar sentiments stating that learning occurs when a student undergoes all four modes. Often, not all four stages are employed when students are engaged in experiential learning, especially when students are being instructed in laboratories. For example, lab activities can regularly create an environment where students are gaining hands-on experience (Concrete Experience and Active Experimentation) by working on

a practical activity (Miller & Hilaire, 2018). However, rarely do labs allow students to critically think, connect past experiences (Reflective Observation) or to grasp and generalize such experience (Abstract Conceptualization).

### **Critical Reflection**

Although the phrase critical reflection is commonly mentioned in higher education, a proper and clear definition is often lacking or absent in higher education literature (Atkins & Murphy, 1993; Bubnys & Zydziunaite, 2010). Nguyesn, Fernadez, Kartsenti, and Charlin (2014) have considered that the lack of a consistent definition has impeded the development and understanding of reflection. Nevertheless, much of the literature that does properly define critical reflection defines it as, an intentional internal cognitive process of analyzing, assessing, reframing and deeply considering a previous experience in order to add meaning or to learn from a given experience (Bubnys & Zydziunaite, 2010; Louise, 2010; Nguyen, Fernandez, Karsenti, & Charlin, 2014).

The phrase critical reflection is often synonymously used with the phrase critical thinking. However, critical reflection is more than just critical thinking, although critical thinking plays a significant role in the reflection process (Nguyen, Fernandez, Karsenti, & Charlin, 2014). Sanders (2009), states the “metacognitive process” known as reflection can occur either before or after an experience, and it is simply a process that helps individuals understand experiences so that future “encounters” with that experience can be influenced (Sandards, 2009, p. 685). The underlying purpose of reflection is to help an individual process or comprehend an action or experience.

The most comprehensive literature review on critical reflection was completed by Nguyen, Fernandez, and Charlin (2014). The authors identified five key components that form

the conceptual framework of reflection. The first is thoughts and actions (TA); the second is attentive, critical, exploratory and iterative process (ACEI); the third is conceptual framework (CF); the fourth is view of change (VC), and the fifth is self (S).

The thoughts and actions component of reflection is considered as the content, experience ideology an individual should be thinking of in order to process an experience or situation. For example, in the case of a laboratory setting, this component would require laboratory students to think about the content or the theory that supports the laboratory activity. Authors such as Dewey (1910) posited that reflection should be done carefully and in an insistentlly:

Reflection is turning a topic over in various aspects and in various lights so that nothing significant about it shall be overlooked almost as one might turn a stone over to see what its hidden side is like or what is covered by it. Thoughtfulness means, practically, the same thing as careful attention; to give our mind to a subject is to give heed to it, to take pains with it. In speaking of reflection, we naturally use the words weigh, ponder, and deliberate— terms implying a certain delicate and scrupulous balancing of things against one another. Closely related names are scrutiny, examination, consideration, inspection— terms which imply close and careful vision. Again, to think is to relate things to one another definitely, to “put two and two together” as we say. Analogy with the accuracy and definiteness of mathematical combinations gives us such expressions as calculate, reckon, account for; and even reason itself— ratio. Caution, carefulness, thoroughness, definiteness, exactness, orderliness, methodic arrangement, are, then, the traits by which we mark off the logical from what is random and casual on one side, and from what is academic and formal on the other ( p.11).

Dewey’s words of careful, logical, scrutiny, examination, consideration and inspection provide unequivocal evidence of Dewey’s thoughts on the reflection process and how it should be effectively used in experiential learning.

The conceptual framework component of reflection is concerned with analyzing the different concepts that govern an experience and questioning the validity and the relevance of the given concepts. The primary concern of this CR component is understanding a problem rather than trying to solve a problem. The fourth central component of critical reflection identified is view on change (VC). This component deals with the transformative dimension of reflection.

Individuals must understand that reflection helps them understand and transform a learning experience. The fifth critical component of reflection is self-component. One of the defining aspects of reflection is how it incorporates or engages individual reflection. The self-component allows the individual to reflect on why they performed a given action during a learning experience.

### **DEAL Reflection Method**

The DEAL (describe, examine and articulate learning) reflection model has been chosen for this study. The DEAL method prescribes an effective process to encourage reflection during an experiential learning experience (Ash & Clayton, 2009). The first step in the DEAL model is to describe the experience. The second step requires students to examine their experience from an academic/theory point of view (Ash & Clayton, 2009). The last step to the DEAL reflection model is to articulate learning. This step allows students to state what they have learned overall. At this stage, students are able to express how they can apply what they have learned to solve future problems (Ash & Clayton, 2009). The authors of the DEAL reflection method originally designed the DEAL method to allow students who participate in a service-learning project to reflect on a given experience they encountered during their service learning activity; however, the authors believe that the DEAL methods can be adopted and implemented in other academic contexts as well (Ash & Clayton, 2009).

### **Theoretical Framework**

Cognitive constructivism, a cognitive learning theory, is the fundamental theory that undergirds this study. Cognitive constructivism asserts that learning occurs when individuals reconstruct or cognitively represent what truly exist (Roberts, 2006). It is a theory that places the student at the center of learning and takes the position that true learning occurs when internal cognitive mechanisms are used to manipulate and transform real-world experiences to learning

(Doolittle & Camp, 1999; Koch, 2010; Martin & Sugarman, 1997). Cognitive constructivism makes use of individual and group thinking processes, such as memory, depictions, attitudes, schemas and mental models (Kayes, 2002).

Such theoretical framework can be traced back to Jean Piaget who identified two main principles of acquiring knowledge, for which he termed the first process of learning as “assimilation” and the other “accommodation” (as cited in Dole & Sinatra, 1998). What Piaget means by this is that learning is built (assimilation) on information that already exists and then modified or changed (accommodation). New information is being reinterpreted by the individual based on previous information; the individual then re-represents this information in their mind in order to understand a given concept.

Cognitive learning theory asserts that learning begins when individuals interact with the external world (Reed, 1996). This information from the outside world is then transformed and re-represented by the individual’s cognition (mental functions) in order to process and make sense of the external world (Rekart, 2013). After new information is transformed and recognized, it is either temporarily or for longer periods of time (Aben, Stapert & Blokland, 2012). The storing of new information is known as memory. Scholars believe memory can be classified as short-term memory (STM), working memory (WM), or long-term memory (LTM) (Aben, Stapert & Blokland, 2012; Cowan, 2008; Reed, 1996; Rekart, 2013; Willingham, 2009).

Short-term memory is described as the “cognitive system” that holds sensory events and new information for a short period of time (Aben, Stapert & Blockland, 2012, p.1). New information that is stored in short term memory, if not rehearsed, may be forgotten in seconds (Alloway & Copello, 2013). STM is used to store information such as lab instructions, phone

numbers, and names. If information is not processed through working memory and then transferred to long-term memory, the new information will be lost or forgotten.

Working memory refers to the information that is actively being processed and manipulated (Aben, Stapert & Blockland). Rekart (2013) considers working memory as thinking “about what to do next,” or engaging in reminiscing (p.55). When individuals reason or problem-solve this process occurs in working memory. Before information can be sorted for longer periods of time, it must first be channeled through STM and WM.

Long-term memory is considered as the long term storage of “factual information” for later use (Willingham, 2009, p. 14). Scholars have divided LTM into two categories known as non-declarative and declarative (Squire & Zola, 1996). Non-declarative is considered as a memory that occurs through the action of doing or performance (Squire & Zola, 1996). Declarative memory, however, is considered as the capacity to intentionally recall information such as facts and previous events in order to display learning (Rekart, 2013). All information regarding long-term memory is stored and organized cognitively and maybe used to support working memory.

The primary difference between short-term memory and long-term memory is duration and capacity (Cowan, 2008). Long-term memories are stored cognitively over a period of time. Rekart noted that long term memory is, “the ability to recall information in the long term, meaning hours, days, years, and even decades after something has occurred or a concept was learned” (p.71). In regards to capacity, more information can be stored and retrieved in long-term memory than short term memory. Scholars agree that there is a limit to how much information can be stored in short-term memory compared to long term memory (Squire & Zola, 1996; Willingham, 2009).



In addition, some cognitive theorists believe that how humans learn to perform different activities can be summarized by the information-processing model (Sharit & Czaja, 2018). The information processing model describes how humans acquire, store and retrieve information (Reed, 1996). Figure 2 presents a graphic that Reed (1996) developed to describe the different stages in the information processing process. This model describes how individuals are first introduced to new information and how they eventually transform that information for later use.

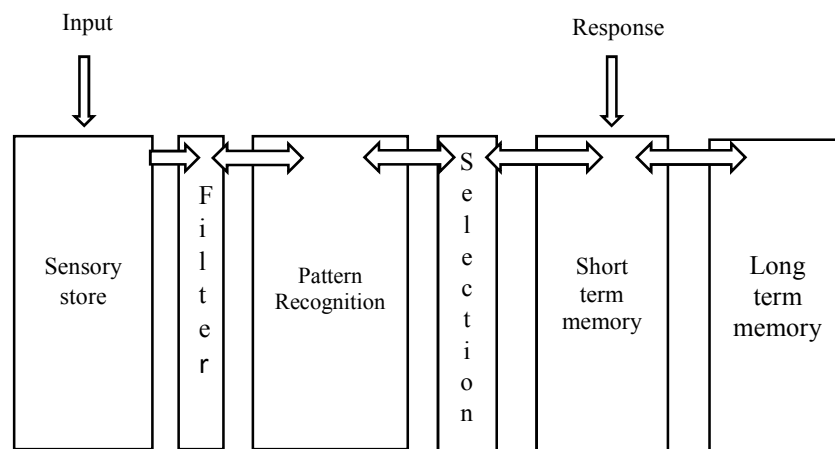

Figure 2. (Reed, 1996) The information-processing model.

The first stage Reed (1996) presents in the information-processing model is the sensory store. At this stage, information from the external world (Reed, 1996) is gathered from the senses and is stored temporally (Sharit & Czaja, 2018). The new information is then filtered and passed to the pattern recognition stage. At this stage, the information from the sensory store is identified or recognized as a pattern if individuals can use previous information stored in memory to recognize familiar patterns. If the pattern is not familiar to the individual, the individual takes additional measures to store or discard that pattern (Reed, 1996). After the information is recognized, the information is entered into short and then transferred to long term memory. The short term memory has a time and capacity limit of how much information can be retained and

stored, however, long term memory does not. The filter stage filter decipheres how much information can be recognized at any one time, and the selection stage limits the volume of information that can be stored into memory (Reed, 1996).

### **Summary**

Experiential learning continues to play a critical role in agricultural education. The underlying principle of experiential learning is that learning occurs by doing. In addition, Kolb (1984) suggested that optimal experiential learning occurs when individuals are introduced to the four stages of experiential learning: concrete experience, reflective observation, abstract conceptualization, and active experimentation. As reviewed in the literature, reflection continues to be an essential component of experiential learning fundamentals, and in order for effective learning to take place, reflection must be employed.

## Chapter III

### Methodology

In this chapter, the overall procedures of how this study was undertaken will be presented. Careful consideration was given to the statement of the problem, purpose of study, design of the study, population, sample, and statistical analysis.

#### **Statement of the Problem**

In order to meet the growing demands of a complex agricultural industry, agricultural educators across the country are being urged to update their curriculum to incorporate effective learning strategies that are supported by proven pedagogical approaches (Deslauriers, Rudd, Westfall-Rudd and Splan, 2016; National Research Council, 2009). Educators now have a responsibility to respond to such challenges by exploring and implementing tested pedagogical approaches into their curriculum; educators in the discipline of agricultural mechanization are not exempt from this challenge.

To respond to the National Research Council challenge, this study sought to explore the benefits of critical reflection on students' cognitive achievements in two agricultural mechanization courses taught at the University of Arkansas. Shoulders and Myers (2013) conducted a study evaluating experiential learning in agricultural laboratories and the study revealed that only 15.4% of the agricultural educators employed reflective practices into their laboratory activity. It is the hope of the researcher to contribute to the existing literature on the effects of experiential learning in agricultural education laboratories by exploring what effects experiential learning has on student performance and retention.

## **Purpose and Objectives**

The purpose of this study was to evaluate the effect of critical reflection on students' achievement following an agricultural mechanization laboratory activity. The primary research question was: What effect does critical reflection have on students' laboratory performance compared to the laboratory performance of students who do not critically reflect? The specific research objectives were to:

1. Determine if there is a difference in immediate cognitive achievement in selected agricultural mechanization topics by the main effect of reflection (no reflection, individual or group reflection).
2. Determine if there is a difference in delayed cognitive achievement in selected agricultural mechanization topics by main effect of reflection (no reflection, individual or group reflection).

## **Research Design**

A simple randomized subjects design was chosen for this study (Christensen, 1984). The independent variable had three levels reflection, no reflection, individual and group reflection. Students were randomly assigned to either a control or experimental group. Once students were randomly assigned to their respective groups, students remained in those groups for the remainder of the study. The researcher used the random function in Excel™ to randomly assign each student to a group of no reflection, individual and group reflection. The no reflection group was coded as one, individual reflection group coded as two and group reflection coded was coded as three.

After students completed their respective laboratory assignment, students received instructions about the study and were told if they were in group one, two or three. Students in

group one, the no reflection group, received an immediate posttest and left the laboratory when they had completed the posttest. In contrast, students who were assigned to group two, the individual reflection group, received a reflection treatment and was prompted to reflect on the previous laboratory experience for 10-15 minutes. After each student individually completed the individual reflection module, they were given an immediate posttest.

Similarly, students that were randomly assigned to group three, the group reflection, received a reflection treatment after they had completed their respective laboratory activity. Students in group three were prompted to first individually reflect, and then directed to discuss what they had individually reflected on as a group. The reflection discussion groups comprised of three to four students. In addition, students in group one, two and three all received delayed posttests two weeks following each initial immediate posttests.

### **Internal Validity of Experiments**

According to Campbell and Stanley (1963), the simple randomized subjects design is considered as a true experimental design. Such design controls for eight all eight threats that often threaten the internal validity of true experimental designs (Campbell & Stanley,1963). The eight threats are history, maturation, testing, instrumentation, statistical regression, selection, experimental mortality, and selection-maturation interaction. Campbell and Stanley (1963) stated that if these threats to validity are not “controlled in experimental design, they might produce effects confounded with the effect of the experimental stimulus” (p.5). In other words, if the threats to internal validity are not controlled for, the researcher cannot be certain the observed differences are due to the experimental treatment. With this in mind, each of the eight threats to internal validity will be listed and discuss below:

1. History is considered as specific events that subjects may encounter between measurements that are not intended to be a part of treatment or the experimental study (Flannelly, Flannelly & Jankowski, 2018). The simple randomized subjects design controls for this because posttest is usually delivered as one natural and single package (Campbell & Stanley, 1963). All students in this study were measured during the same laboratory period and no time lapsed between measurements.
2. Maturation is considered as the change over time that may exist in the subjects during the duration of the experiment (Koch, 2010). For instance, if participants become older, hungry or fatigued (Flannelly, Flannelly, & Jankowski, 2018). Maturation was controlled for by immediately conducting the study after the laboratory activity was completed by students. In addition, the reflection treatments only lasted 10-15 minutes and each posttest had comparable completion times. Thus, the study tested 20-30 minutes.
3. Testing is known as the measurement effects that may be influenced by taking a pretest and then taking a posttest (Campbell & Stanley, 1963). Simple randomized subjects design controls for this because only a posttest is administered after the treatment is administered.
4. Instrumentation is when changes in the dependent variable occur because of some external or internal change of the instrument (Campbell & Stanley, 1963). To control for this, the format and instructors administering the treatment remained the same.
5. Statistical Regression is considered as a tendency of some participants having very high or low mean test scores (Flannelly, Flannelly, & Jankowski, 2018). Simple randomized subjects design randomly assigns all participants into the various control and

experimental groups; thus, the simple randomized subjects design controlled for the threat of statistical regression.

6. Selection is referred to as the difference that may exist between the control and experimental group that are not intended to be a part of the experimental study (Campbell & Stanley, 1963). Simple randomized subjects design controls for this because groups are comparable and all subjects are randomly assigned to both the control and experimental group (Christensen, 1984).
7. Experimental mortality is the differential losses of respondents between the control and experimental group (Campbell & Stanley, 1963). However, this threat was controlled for by removing students from the delayed posttest analysis if they were not present for the immediate posttest.
8. Selection-maturation interaction refers to the different maturation rates that may exist among participants of an experimental study (Koch, 2010). Simple randomized subjects design controls for this because individuals were randomly assigned to each group, so those who were commonly absent were equally distributed among the control and experimental groups.

## **Population**

The accessible population ( $N = 60$ ) for this study was all students enrolled in two agricultural mechanization courses taught at the University of Arkansas. The first course that was targeted for this study was Electricity in Agriculture laboratory (AGME 3173). The total number of students enrolled in this course was 24 at the start of the semester. The second course targeted for this study was Small Power Units/Turf Equipment laboratory (3101L), and the total number of students enrolled in Small Power Units/Turf Equipment was 36. Moreover, two students

withdrew from AGME 3173L five weeks after the course began, which left the total number of students enrolled in Electricity in Agriculture to 22. One student also withdrew from Small Power Unit/Turf Equipment six weeks after the course began which reduced the student population to 35. As a result, the accessible population was reduced to 57 students.

The majority of participants in this study were male (93%) with the remainder of the participants being female (7%). Student classification varied from freshmen, sophomores, juniors, and seniors. In Electricity in Agriculture, freshmen ( $n = 1$ ) accounted for 4% of the total students; sophomores ( $n = 5$ ) represented 21% of the total students; juniors ( $n = 11$ ) represented 46% of the total students; and seniors ( $n = 7$ ) represented 29% of the total students. In Small Power Units/Turf Equipment, freshmen ( $n = 1$ ) accounted for 2% of the total students; sophomores ( $n = 8$ ) represented 23% of the total students; juniors ( $n = 10$ ) represented 26% of the total students; and seniors ( $n = 17$ ) represented 49% of the total students. This study was reviewed by the Institutional Review Board Committee at the University of Arkansas and approved on January 24, 2019, IRB protocol # 1809145873.

### **Instrument**

The instruments used to measure immediate and delayed cognitive achievement were developed by the researcher. Cozby and Bates (2015) suggested five indicators that ensure construct validity. Face and content validity were assessed for the instruments used in this study.

1. Face validity was addressed for each instrument by comparing each posttest question to the lesson objectives of each respective laboratory activity and subject matter. Questions that did not adequately measure the specific laboratory objectives were dropped from the posttests.



2. Content validity was accounted for by a panel of experts in the Agricultural Education, Communications and Technology department at the University of Arkansas. After each instrument was developed for Electricity in Agriculture, the professor reviewed the instrument to ensure it appropriately reflected the instructional objectives of each laboratory activity. Similarly, the instructor of Small Power Units/Turf Grass Equipment reviewed each instrument for content validity.

The Posttest used for experiment one contained 10 multiple-choice questions each and was administered as unannounced pop-quiz in Electricity in Agriculture. Students were required to recall information regarding AC resistive circuits. The immediate posttest had a coefficient alpha of .72. In addition, the delayed posttest was given two weeks after the immediate posttest was administered, and contained seven multiple choice questions. The delayed posttest was administered to students as an announced quiz. The delayed posttest had a coefficient alpha of .65.

The second experiment was conducted in Electricity in Agriculture. The immediate posttest had 10 multiple-choice questions. Students were required to recall information regarding AC circuit analysis. The posttest was administered as an unannounced pop-quiz, and the coefficient alpha for the immediate posttest was .67. Due to a scheduled hourly examination in Electricity in Agriculture, delayed posttest one and two were administered on the same day. The delayed posttest was a modified version of posttest one and two. Due to time constraints, three of the original items were deleted from immediate posttest two. This reduced the total number of items on posttest two to seven. The delayed posttest in experiment two was announced one week prior and then administered at the beginning of the laboratory.

The posttest used in experiment three contained eight-items because of the length and content of the Small Power Unit/Turf Grass Equipment laboratory. The posttest required students to recall information about carburetors systems in small power units. The immediate posttest had a coefficient alpha of .53 and was administered as an announced pop quiz. The delayed posttest was a modified version of the immediate posttest and was administered as a pop-quiz two weeks after the initial posttest was given. The delayed posttest used in experiment three had six multiple-choice questions and the coefficient alpha was .29.

The Posttest used for experiment four contained 12 multiple-choice questions each and was administered as unannounced pop-quiz in Small Power Units/Turf Grass Equipment. Students were required to recall information regarding battery and ignition systems in small power units. The immediate posttest had a coefficient alpha of .60. In addition, the delayed posttest was given two weeks after the immediate posttest was administered. The delayed posttest was administered to students as an announced quiz. The delayed posttest had six multiple-choice questions and had a coefficient alpha of .50.

The immediate posttest for experiment five had 10-multiple-choice questions. Students were required to recall information regarding electrical motors in agriculture. The posttest was administered as an unannounced pop-quiz, and the coefficient alpha for the immediate posttest was .74. The delayed posttest was a modified version of the immediate posttest, and it had six multiple-choice questions. The coefficient alpha was .48. In addition, the delayed posttest in experiment five was an announced pop quiz.

## **Treatment**

The treatments for this study were developed by the researcher. Each reflection treatment was based on the laboratory objectives and was based on the DEAL reflection model (Ash &

Clayton, 2009). The DEAL model requires students to describe their laboratory experience and examine the specific information relevant to the previous experience. Students were prompted to articulate what they had learned in the laboratory by giving clear descriptions of the concepts of what they had previously learned during the laboratory (Ash & Clayton, 2009). The reflection treatments typically contained six to nine items. The same reflection treatment was used for both experimental groups.

### **Data Collection Procedures**

Data obtained in this study were collected in laboratory sections of two junior-level agricultural mechanization courses at the University of Arkansas during the spring 2019 semester. The two courses were Small Power Units and Turf Equipment and Electricity in Agriculture. The Small Power Units and Turf Equipment laboratory provided students practical experiences in testing, evaluating and maintaining small engines, hydrostatic power transmission systems commonly used in turf and landscaping industries. The Electricity in Agriculture laboratory provided students practical experiences in applying the principles of electricity, wiring, and selection and use of electric motors and controls in the broad field of agriculture. After students completed the laboratory activity, they were randomly assigned to either a no reflection, group or individual reflection group. Once students were initially randomly assigned to either a no reflection, individual or group reflection group, students remained in these respective groups for the remainder of the study. . Those who were assigned to the no reflection group were given an immediate posttest and left the laboratory once the posttest was completed.

### **Experiment One: AC Resistive Circuits**

Experiment one was conducted in Electricity in Agriculture under the subject matter of AC resistive circuits. The AC resistive circuit's laboratory required students ( $n = 22$ ) to learn

how to use a multimeter, record electrical measurements such as voltage, electrical current, and resistance in resistive circuits

Moreover, students in the individual reflection group ( $n = 8$ ) was given a reflection treatment that contained eight reflection items. Each reflection treatment took 10-15 minutes. After each student assigned to the individual group reflected individually, they were given an immediate posttest. The individuals assigned to the group reflection ( $n = 7$ ) were instructed to first individually reflect followed discussion in a group reflection. Because some students completed their laboratory activity before others, some groups were reduced to three or two. After each group completed their discussion, they were then given a posttest. The control group had seven students, and once each student in the control group completed their laboratory, they were given a posttest. After two weeks, the delayed posttest containing 10-items was administered to all of the students ( $n = 22$ ).

### **Experiment Two: AC Circuit Analysis**

The second experiment was conducted in an Electricity in Agriculture laboratory under the subject matter of AC circuit analyze. Students ( $n = 21$ ) that participated in the laboratory were required to identify resistive, inductive, and capacitive loads in AC electrical circuits. Students were then required to determine the total impedance ( $Z$ ) in an AC circuit and divide reactance circuit loads into resistive and inductive components. Those in the control group ( $n = 7$ ) received a posttest and subsequently left the laboratory after the posttest was completed. On the other hand, those in the experimental groups received a four-item reflection treatment. The reflection treatment lasted 10 minutes for students who reflected individually ( $n = 7$ ). Similarly, the group reflection ( $n = 7$ ) lasted for 10-15 minutes. Students in the experimental groups received a posttest following the reflection treatment. Instead of administering the delayed posttest two weeks after the study was initially conducted, the posttest was administered a week

earlier because of an hourly exam that was already scheduled in Electricity in Agriculture. Three students were absent when this experiment was conducted. This resulted in a reduced sample ( $n = 21$ ) of twenty-one; those that were absent were not included in the delayed posttest analysis.

### **Experiment Three: Carburetor Systems**

The third experiment was conducted in Small Power Units/Turf Grass Equipment concerning the subject matter of carburetor systems. Students ( $n = 27$ ) were required to identify the types of air filters and carburetor used in small power equipment. Students were also required to learn how to service air filters according to manufacturer's recommendations. After the students were done with the laboratory activity, each student was randomly assigned to a control (no reflection) or experimental groups (individual or group reflection). Once students were initially randomly assigned to either a no reflection ( $n = 11$ ), individual ( $n = 7$ ) or group ( $n = 9$ ) reflection, students remained in these respective groups for the remainder of the study. Students in both the control group and experimental groups received an eight-item multiple-choice posttest that was based on the lab content. The reflection treatment lasted for 10-15 minutes.

On the day this experiment was conducted, nine students were absent, reducing the sample ( $n = 28$ ) of thirty-seven to twenty-eight. The delayed posttest was administered two weeks after the initial study (experiment three) was conducted. Those students ( $n = 2$ ) who were absent were not included in the delayed posttest analysis.

### **Experiment Four: Principles of Electricity in Small Power Equipment**

The fourth experiment was undertaken in Small Power Units/Turf Equipment laboratory. The laboratory content for experiment four was the principles of electricity, battery and ignition systems as it relates to small power units. Each student was required to learn how to use a hydrometer to determine the condition of an automotive-type battery, test alternator conditions using an ohmmeter, identify the components of ignition system and perform an ignition test to

determine if spark quality is adequate. Students assigned to the control group ( $n = 12$ ) received a posttest after they had completed the laboratory. Conversely, the two experimental groups ( $n = 20$ ) received an eight-item reflection treatment. After students in the experimental groups were done with the reflection treatment, they received a 12-item multiple-choice posttest regarding the laboratory content. The reflection treatment lasted for 10-15 minutes. Students that were not present for the immediate posttest were not included in the delayed posttest analysis.

### **Study Five: Electric Motors in Agriculture**

The final experiment was conducted in Electricity in Agriculture laboratory. The subject matter for experiment five was electric motors types, uses, and wiring as it relates to agriculture. The laboratory activity required students ( $n = 19$ ) to identify common types of motors, identify types of motor enclosures, interpret electric motor nameplates, and interpret electric motor wiring diagrams for both low and high voltages. Participants in the control group ( $n = 5$ ) were simply given a 12-item multiple choice posttest and after each student completed the posttest, they left the laboratory. In contrast, the experimental groups ( $n = 14$ ) received an eight-item reflection treatment, and after they were done with the reflection, they were given the same 12-item multiple choice posttest. The reflection treatment lasted for 10-15 minutes. The delayed posttest was administered two weeks after the initial study was conducted.

### **Statistical Analysis**

Students' responses to each posttest were all collected at the same time, graded, and responses to each item were recorded in Excel. The responses of the students were coded as one if students selected the correct answer and coded zero if students did not select the correct answer. The SAS 9.4 statistical package was used to organize and examine the data for each experiment. Because this was a population study, descriptive statistics were used to summarize the results of each experiment. Means and standard deviations were reported to summarize the

immediate and delayed posttest results. Eta Squared (Cohen, 1988) was calculated and used to quantify any observed effect of the treatment on group mean scores.

## Summary

This study was conducted to determine the effects of reflection on students' immediate and delayed cognitive achievement in two agricultural mechanization laboratory courses. Five experiments were conducted in the two courses during the spring 2019 semester using a randomized subjects design. Table 1 summarizes these five experiments.

Table 1

*Summary of Experiments, Laboratory Content and Posttest Reliability*

Experiment	Course	Subject Matter	Students	Test Reliability (Coefficient <i>alpha</i> )
One	AGME 3173L	AC Resistive Circuits	Control ( <i>n</i> = 7) Ind. Reflection ( <i>n</i> = 8) Group Reflection ( <i>n</i> = 7)	Immediate posttest ( $\alpha = .72$ ) Delayed posttest ( $\alpha = .65$ )
Two	AGME 3173 L	AC Circuit Analysis	Control ( <i>n</i> = 7) Ind. Reflection ( <i>n</i> = 7) Group Reflection ( <i>n</i> = 7)	Immediate posttest ( $\alpha = .67$ ) Delayed posttest ( $\alpha = .64$ )
Three	AGME 3101L	Carburetor Systems	Control ( <i>n</i> = 11) Ind. Reflection ( <i>n</i> = 7) Group Reflection ( <i>n</i> = 9)	Immediate posttest ( $\alpha = .53$ ) Delayed posttest ( $\alpha = .29$ )
Four	AGME 3101L	Small Equipment Electrical and Ignition Systems	Control ( <i>n</i> = 12) Ind. Reflection ( <i>n</i> = 9) Group Reflection ( <i>n</i> = 11)	Immediate posttest ( $\alpha = .60$ ) Delayed posttest ( $\alpha = .50$ )
Five	AGME 3173L	Electrical Motors in Agriculture	Control ( <i>n</i> = 5) Ind. Reflection ( <i>n</i> = 8) Group Reflection ( <i>n</i> = 6)	Immediate posttest ( $\alpha = .74$ ) Delayed posttest ( $\alpha = .48$ )

## Chapter IV

### Results

The focal point of chapter four is to present the research findings regarding the effect reflection methods (individual and group reflection) have on students' cognitive achievement when completing agricultural mechanization laboratory activities. The results are organized by individual experiment. The data presented in this chapter were collected during the spring semester of 2019. Five experiments were conducted in laboratory sections of two agricultural mechanization courses taught at the University of Arkansas; Electricity in Agriculture Laboratory and Small Power Units/Turf Equipment.

#### **Population**

The accessible population ( $N = 60$ ) for this study was all students enrolled in two agricultural mechanization courses taught at the University of Arkansas. The first course targeted for this study was Electricity in Agriculture laboratory. The total amount of students enrolled in this course was 24 at the start of the semester. The second course targeted for this study was Small Power Units/Turf Equipment laboratory, and the total number of students enrolled in Small Power Units/Turf Equipment was 36 students.

During the course of the semester, several students withdrew from Electricity in Agriculture and Small Power Units/Turf Equipment laboratory. Two students withdrew from AGME 3173L five weeks after the course began, which left the total number of students enrolled in AGME 3173L to 22. One student also withdrew from AGME 3173L six weeks after the course began which reduced the student population in AGME 3173 L to 35. This resulted in the accessible population being reduced to 57 students.



## Summary of Methodology

Each laboratory began, students were given an overview of how this study would also be a part of their laboratory activity. Once students completed their laboratory experience, each student was randomly assigned to one of three groups, no reflection, individual or group reflection. Students who were assigned to the control group (no reflection) was given a posttest, and when they had completed the 10-item posttest, the students in the control group left the laboratory.

Students in the group reflection were required to first individually reflect, and then discuss their results in groups of three or four. The individual reflection group was instructed to individually reflect using the reflection treatment. After each student or group were done with the reflection treatment, they were given a 10-item immediate posttest. Two weeks after the immediate posttest was administered in Electricity in agriculture, a delayed posttest was given to all the students who participated in experiment one.

Experiment three and four were conducted in Small Power Units/Turf Grass Equipment ( $n = 37$ ) laboratory. After each student completed their laboratory activity, students received instructions regarding the study and were given a consent form to sign if they agreed to participate in the study. After students were given additional instruction about the study, they were randomly assigned to one of three groups, no reflection, individual or group reflection. Students who were assigned to the control group (no reflection) were required to complete a posttest and when they completed the 10-item posttest, students left the laboratory.

The individual and group reflection groups in Electricity in Agriculture and Small Power Units/Turf Grass Equipment first received a reflection treatment that was model based on the DEAL reflection method (Ash & Clayton, 2009). Students in the group reflection were required to first reflect individually, and then reflect in groups of three or four. Students assigned to the

individual reflection group were instructed to individually reflect by using the reflection treatment. After each student was done with the reflection treatment, they were given a 10-item immediate posttest. Two weeks later, a delayed posttest was also administered.

### Experiment One

In order to measure immediate cognitive achievement regarding the lab content, the researcher developed a 10-item multiple-choice test (coefficient alpha = .72). A modified version of the initial 10-item posttest was used to measure delayed cognitive achievement (coefficient alpha = .45). However, deleting items one, five, and seven resulted in a reliability of .65; therefore, the delayed posttest scores were calculated on the reduced, seven-item test. The coefficient alpha reliability of the 10-item post-test was .49; however deleting items one, five, and seven increased the reliability to .65.

Table 2 presents the descriptive results for students ( $n = 22$ ) who participated in experiment one. On the day this experiment was conducted, two students were absent, and were not included in analysis of the delayed posttests.

Table 2

*Summary Results for AC Resistive Circuit Analysis Laboratory by Treatment of No, Individual and Group Reflection*

Achievement	<u>No Reflection</u>			<u>Individual Reflection</u>			<u>Group Reflection</u>		
	<i>M</i>	<i>SD</i>	<i>n</i>	<i>M</i>	<i>SD</i>	<i>n</i>	<i>M</i>	<i>SD</i>	<i>n</i>
Immediate	5.71	2.43	7	6.25	2.49	8	7.42	2.53	7
Delayed	5.00	2.38	7	5.13	1.64	8	5.86	.90	7

Maximum score possible was 10 for the immediate posttest and 7 for delayed posttest.

The results in Table 2 indicated that the students who were prompted to reflect as a group scored slightly higher on the immediate and delayed posttests compared to the students who reflected individually. The group reflection also had a higher posttest score than that of the no reflection group. The eta squared 0.08 indicated that 8% of the total variance found in immediate posttest scores in study one can be accounted for by reflection group (Laken, 2013). The Eta Squared of 0.08 indicated that reflection had an overall medium effect (Cohen, 1988) on immediate posttest scores. In comparison, the eta squared of 0.05 indicated that 5% of the total variance found in delayed posttest scores can be accounted for by reflection group (Laken, 2013). Additionally, the eta squared of 0.05 indicated that reflection had a small effect (Cohen, 1988) on delayed posttest scores.

## **Experiment Two**

The immediate posttest used in the second experiment was a 10-item multiple-choice test that was based on the laboratory content. The immediate posttest has a coefficient alpha of .67. A modified version of the initial 10-item immediate posttest was used to measure delayed cognitive achievement. The original delayed posttest had a coefficient alpha of .26; however, in order to increase the reliability of the delayed posttest in the second experiment, items 3 and 6 were deleted. As a result, the coefficient alpha increased to .64. Three students were absent when this study was administered. This resulted in a reduced sample of 21; those that were absent were not included in the delayed posttest analysis. Table 3 highlights the results yielded from the statistical analysis.

Table 3

*Summary Results for AC Circuit Laboratory by Treatment*

Achievement	<u>No Reflection</u>			<u>Individual Reflection</u>			<u>Group Reflection</u>		
	<i>M</i>	<i>SD</i>	<i>n</i>	<i>M</i>	<i>SD</i>	<i>n</i>	<i>M</i>	<i>SD</i>	<i>n</i>
Immediate	5.71	1.97	7	7.43	1.67	7	8.00	1.19	7
Delayed	4.00	0.00	7	3.14	1.21	7	3.57	.79	7

*Note.* Maximum score possible was 10 on the immediate posttest and 4 on the delayed posttest.

The results presented in Table 3 indicated that students who were prompted to reflect as a group scored slightly higher on the immediate posttest compared to the students who reflected individually or did not reflect. However, on the delayed posttest, students in the no reflection group had slightly higher scores than those in the experimental groups. The eta squared of 0.25 indicated that 25% of the total variance in immediate posttest scores in experiment two can be accounted for by reflection group. Moreover, the eta squared of 0.25 also indicates that reflection had an overall large effect (Cohen, 1988) on immediate posttest scores. In contrast, the students in the control group scored higher in the delayed posttest score than students in the experimental group. The eta squared of 0.16 indicated that 16% of the total variance in the delayed posttest scores can be accounted for by reflection group. The eta squared also indicated that there was a large difference (Cohen, 1988) between the control and experimental group delayed posttest scores.

### **Experiment Three**

The instrument utilized to measure immediate cognitive achievement in the servicing and repairing carburetors laboratory had an initial coefficient alpha of .48. In order to increase the reliability of the immediate posttest, items one, five, and eight were removed from the

instrument. This resulted in an increased reliability with a coefficient alpha of .53. A modified version of the immediate posttest was used to measure delayed cognitive achievement in study three. The original coefficient alpha was .14, however, in order to increase the reliability of the delayed posttest, item two was deleted. As a result, the coefficient alpha increased to .29. The delayed posttest was administered two weeks after experiment three was first conducted.

Students who were absent were not included in the delayed posttest analysis. On the day this experiment was conducted, a total of nine students were absent, reducing the sample 27. Table 4 presents the descriptive statistical results for the third experiment conducted in the servicing and repairing carburetor systems laboratory.

Table 4

*Summary Results for Servicing and Repairing Carburetors Systems by Treatment*

Achievement	<u>No Reflection</u>			<u>Individual Reflection</u>			<u>Group Reflection</u>		
	<i>M</i>	<i>SD</i>	<i>n</i>	<i>M</i>	<i>SD</i>	<i>n</i>	<i>M</i>	<i>SD</i>	<i>n</i>
Immediate	3.55	1.15	11	4.57	.73	7	4.22	1.13	9
Delayed	3.10	.88	10	3.33	.82	6	2.63	1.06	8

*Note:* Maximum score possible was 5 on immediate posttest and 4 on the delayed posttest.

The results presented in Table 4 indicate that the students who were prompted to reflect individually scored slightly higher on the immediate posttest compared to the students who did not reflect or students that reflected as a group. On the delayed posttest, students in the individual reflection group scored slightly higher than group reflection or no reflection students. The eta squared of 0.14 indicated that 14% of the total variance found in immediate posttest scores in experiment three can be accounted for by reflection group. Thus, the eta squared of 0.14 indicated that reflection had an overall large effect (Cohen, 1988) on immediate posttest scores.

In comparison, the eta squared of 0.09 indicated that 9% of the total variance found in delayed posttest scores was accounted for by reflection group. The eta squared of 0.09 indicated that reflection had a medium effect (Cohen, 1988) on delayed posttest scores.

#### Experiment Four

The instrument used to measure cognitive achievements in the battery and ignition systems in small equipment laboratory had an initial coefficient alpha of .40. In order to increase the reliability of the instrument, items one, two, three, six, eight and 10 were deleted, leaving six items analyzed for the posttest (coefficient  $\alpha = .60$ ). A modified version of the immediate posttest was used to measure delayed cognitive achievement in experiment four. The original coefficient alpha was .16, however, to increase the reliability of the delayed posttest, items two and four were deleted, leaving four items in the delayed posttest (coefficient  $\alpha = .50$ ). The delayed posttest was administered two weeks after the initial study was conducted in Small Power Units/Turf Grass Equipment. When the delayed posttest was administered, three students that were present during experiment four were absent. Table 5 presents the descriptive statistics for the students who participated in experiment four.

Table 5

*Summary Results for Battery and Ignition Systems by Treatment*

Achievement	No Reflection			Individual Reflection			Group Reflection		
	<i>M</i>	<i>SD</i>	<i>n</i>	<i>M</i>	<i>SD</i>	<i>n</i>	<i>M</i>	<i>SD</i>	<i>n</i>
Immediate	2.42	2.07	12	3.78	1.20	9	3.73	1.42	11
Delayed	2.50	1.31	12	3.00	.93	8	2.89	.93	9

*Note.* Maximum possible score was 6 on the immediate posttest 4 on the delayed posttests.

The results presented in Table 5 indicate that the students who were prompted to reflect individually scored slightly higher on the immediate and delayed posttests compared to the students who did not reflect or reflected as a group. The eta squared of 0.02 indicated that 2% of the total variance found in immediate posttest scores in study four can be accounted for by reflection group. In addition, the eta squared of 0.02 indicates that reflection had a small effect (Cohen, 1988) on immediate posttest scores. In comparison, the eta squared of 0.03 indicated that 3% of the total variance found in delayed posttest scores can be accounted for by reflection group. Additionally, the eta squared of 0.03 indicated that reflection had an overall small effect (Cohen, 1988) on delayed posttest scores.

### **Experiment Five**

The instrument used to measure cognitive achievements in the electrical motors in agriculture laboratory had an initial coefficient alpha of .64. However, to increase the reliability of the instrument, items two, four, six, seven, eight, and were removed from the data analysis. As a result, the coefficient alpha was increased to .74. On the day experiment five was conducted, one student was absent which resulted in only 21 participants. Two students were dropped from the data analysis because one of the students was assigned to the control group but mistakenly took part in the experimental group. The other student took part in a group reflection when he was randomly assigned to an individual reflection group. This resulted in both students being removed from the analysis which reduced the sample 19.

A modified version of the immediate posttest was used to measure delayed cognitive achievement in experiment five. The original coefficient alpha was .16; however, to increase the reliability of the delayed posttest, items two and four were deleted. As a result, the coefficient alpha increased to .48. The delayed posttest was administered two weeks after the initial study

was conducted in Electricity in Agriculture. Table 5 presents the descriptive statistics for those students who participated in study five.

Table 6

*Summary Results for Electrical Motors in Agriculture Laboratory by treatment*

Achievement	<u>No Reflection</u>			<u>Individual Reflection</u>			<u>Group Reflection</u>		
	<i>M</i>	<i>SD</i>	<i>n</i>	<i>M</i>	<i>SD</i>	<i>n</i>	<i>M</i>	<i>SD</i>	<i>n</i>
Immediate	3.60	1.67	5	3.75	2.12	8	4.17	1.94	6
Delayed	3.00	1.00	5	2.63	1.41	8	3.50	.55	6

*Note:* Maximum score possible was 6 on the immediate posttest and 4 on the delayed posttest.

The results presented in Table 6 indicates that the students who were prompted to reflect as a group scored slightly higher on the immediate posttest compared to the students who reflected individually. However, students in the group reflection scored slightly higher on the delayed posttest compared to the students who individually reflected or who did not reflect. The eta squared 0.02 indicated that 2% of the total variance found in immediate posttest scores in study five can be accounted for by reflection group. The eta squared of 0.02 indicated that reflection had a small effect (Cohen, 1988) on immediate posttest scores. In comparison, the eta squared of 0.12 indicated that 12 % of the total variance found in delayed posttest scores can be accounted for by reflection group. Additionally, the eta squared of 0.12 indicated that reflection had an overall medium effect (Cohen, 1988) on delayed posttest scores.

**Summary**

This chapter reported the results of five experiments conducted to determine the effects of reflection on immediate and delayed cognitive achievement in two university agricultural mechanization laboratory courses. The students in the two reflection groups had higher mean



immediate cognitive achievement scores in all five experiments compared to students in the no reflection groups. The eta-squared effect size measures ranged from .02 (Experiments four and five) to .25 (Experiment 2), indicating the effects of reflection on immediate cognitive achievement ranged from small to large (Cohen, 1988). However, the results varied for the delayed posttest scores. The control group scored higher on the delayed posttest than the experimental groups in experiment two, and in experiment three the control group had higher mean score than group reflection, and in study five, the control group scored higher than the individual reflection group. The eta-squared effect size measures ranged from 0.05 (Experiments one) to 0.12 (Experiment 5), indicating the effects of reflection on immediate cognitive achievement ranged from small to medium (Cohen, 1988). Table 7 presents a qualitative summary of the findings for all five of the experiments.

Table 7

*Qualitative Summary Assessment of Posttest Scores for All Five Experiments*

Experiment	Lowest	Intermediate	Highest
<b>Experiments One</b>			
Immediate Posttest	No Reflection	Individual Reflection	Group Reflection
Delayed Posttest	No Reflection	Individual Reflection	Group Reflection
<b>Experiments Two</b>			
Immediate Posttest	No Reflection	Individual Reflection	Group Reflection
Delayed Posttest	Group Reflection	Individual Reflection	No Reflection
<b>Experiments Three</b>			
Immediate Posttest	No Reflection	Group Reflection	Individual Reflection
Delayed Posttest	Group Reflection	No Reflection	Individual Reflection
<b>Experiments Four</b>			
Immediate Posttest	No Reflection	Group Reflection	Individual Reflection
Delayed Posttest	No Reflection	Group Reflection	Individual Reflection
<b>Experiments Five</b>			
Immediate Posttest	No Reflection	Individual Reflection	Group Reflection
Delayed Posttest	Individual Reflection	No Reflection	Group Reflection

## Chapter V

### Summary, Conclusions, Implications, and Recommendations

Experiential learning continues to play a vital role in agricultural education and mechanization. Although experiential learning has been discussed in detail in agricultural education literature (Shoulders, Wyatt, & Johnson, 2014), little research exists regarding critical reflection. The purpose of this study was to evaluate the effect of critical reflection on students' achievement following an agricultural mechanization laboratory activity. The primary research question was: What effect does critical reflection have on students' laboratory performance compared to the laboratory performance of students who do not critically reflect? With that understanding, several conclusions and recommendations regarding the findings will be presented in this chapter.

#### **Conclusions**

The overall results revealed that reflection had an effect on immediate cognitive achievement among students in Electricity in Agriculture and Small Power Units and Turf Equipment. However, the findings from this study seemed to indicate that reflection had no effect on students delayed cognitive achievement. Each experiment will be summarized by each objective of this study.

#### **Objective 1**

The first objective of this study was to determine if there was a difference in immediate cognitive achievement in selected agricultural mechanization topics by the main effect of reflection (no reflection, individual or group reflection). The results from experiment one indicated that students who were prompted to reflect as a group scored slightly higher on the immediate posttest compared to the students who reflected individually or who did not reflect at

all. The results also revealed that students in the experimental groups (individual and group reflection) had higher posttest scores than the control group (no reflection). The reflection treatment in experiment one accounted for 8% of the total variance found in immediate posttest scores which represents a medium effect (Cohen, 1998).

The results from the second experiment revealed that students who were prompted to reflect as a group scored slightly higher on the immediate posttest compared to the students who reflected individually or who did not reflect at all. The control group had the lowest mean score compared to that of the experimental groups. The reflection treatment in experiment two accounted for 25% of the total variance found in immediate posttest scores which represents a large effect (Cohen, 1998).

In addition, the results from the third experiment revealed that students who were prompted to reflect individually scored slightly higher on the immediate posttest compared to the students who reflected as a group or who did not reflect at all. The results also indicated that students in the experimental groups (individual and group reflection) had higher posttest scores than the control group (no reflection). The treatment of reflection in experiment three accounted for 14% of the total variance found in immediate posttest scores. The reflection treatment in experiment three accounted for 14% of the total variance found in immediate posttest scores which represents a medium effect (Cohen, 1998).

Similar to experiment three, the results from the fourth experiment revealed that students who were prompted to reflect individually slightly higher on the immediate posttest compared to the students who reflected as a group or who did not reflect at all. The control group had the lowest mean score in comparison to that of the experimental groups. The reflection treatment in

experiment four accounted for 2% of the total variance found in immediate posttest scores which represents a small effect (Cohen, 1998).

The last experiment, experiment five revealed that students who were prompted to reflect as a group scored slightly higher on the immediate posttest compared to the students who reflected individually or who did not reflect at all. The control group had the lowest mean score compared to that of the experimental groups. The treatment in experiment two accounted for 2% of the total variance found in immediate posttest scores which represents a small effect (Cohen, 1998).

## **Objective 2**

The second objective of this study was to determine if there was a difference in delayed cognitive achievement in selected agricultural mechanization topics by main effect of reflection (no reflection, individual or group reflection). The results from experiment one revealed that students who reflected as a group scored slightly higher on the delayed posttest that was administered two weeks after the initial experiment was conducted. The control group possessed the lowest delayed achievement mean scores in experiment one. Moreover, the reflection treatment accounted for 5% of the total variance found in delayed posttest scores which represents a small effect (Cohen, 1998).

In addition, the delayed posttest was administered a week following the initial posttest that was administered in experiment two. The results revealed that students in the controlled group scored slightly higher on the delayed posttest in comparison with the experimental groups. The reflection treatment accounted for 16% of the total variance found in delayed posttest scores which represents a large effect (Cohen, 1998).

The results from experiment three revealed that students who reflected individually scored slightly higher on the delayed posttest that was administered two weeks after the initial

experiment was conducted. The no reflection group had a higher mean score than that of the students who were prompted to reflect as a group. Moreover, the reflection treatment seemed to account for 9% of the total variance found in delayed posttest scores which represents a medium effect (Cohen, 1998).

The results from study four revealed that students who reflected as a group scored slightly higher on the delayed posttest. The no reflection group had the lowest delayed posttest mean. The reflection treatment accounted for 3% of the total variance found in delayed posttest scores which represents a small effect (Cohen, 1998).

The final delayed posttest was administered in study five. The results revealed that students in the control group scored slightly higher on the delayed posttest in comparison with the experimental groups. The reflection treatment accounted for 12% of the total variance found in delayed posttest scores which represents a medium effect (Cohen, 1998).

### **Limitations**

This study was limited to the population ( $N = 60$ ) of Electricity in Agriculture and Small Power Units/Turf Grass Equipment and should not be generalized beyond this population. In addition, once students were randomized in the first study, students remained in their respective groups throughout the duration of this study. Although this study did not seek to comprehensively measure all variables that could have affected student performance, such variables could be taken into account. Such extraneous variables might include, students' background in the subject matter, distractions, or other factors.

### **Implications for Practice**

Agricultural education and mechanization researchers have often reported the importance of experiential learning in agricultural education and laboratories (Johnson, Wardlow & Franklin, 1998; Shoulders & Myers 2013). A critical component of experiential learning is

critical reflection, however, research has indicated that reflection is often not implemented in experiential learning experiences in scientific and agricultural laboratories (Abdulwahed & Nagy, 2009; Shoulders & Myers, 2013). The results from this study revealed that incorporating reflection into the laboratory experiences of students enrolled in Electricity in Agriculture and Small Power Units can be beneficial to immediate achievement. The findings also indicated that reflection was beneficial in helping students activate and store laboratory content in short term memory. Agricultural education and mechanization educators may seek to incorporate such reflective practices into their respective laboratories and lesson plans to see if the same effects are observed.

In addition, the results revealed that students who reflected as a group in this study had higher immediate posttest mean scores more often compared to the students who individually reflected. Practitioners who are interested in implementing experiential learning into their laboratory activities should look into employing group reflection into such laboratory experiences. Each reflection treatment in this study was formatted and modeled using the DEAL reflection model (Ash & Clayton, 2009). This model seemed to provide students with clear instruction and format on how to reflect after a laboratory experience. Practitioners may also look into implementing the DEAL reflection method into their experiential learning laboratory activities or instruction.

### **Implications for Further Research**

Although in each of the experiments, immediate posttest scores were higher in the treatment groups (individual or group reflection), this was not always true for three of the delayed posttests. In experiment two, three and five, the statistical analysis yielded the control group scoring higher on the delayed posttest scores compared to those who had received a

reflection treatment. Given the results from the data, reflection seemed to have no to small effect on students' delayed cognitive achievement overall. Newsome (2004) indicates that students possess different levels of knowledge; the different levels or the ability to retain knowledge may be one of the variables that could possibly explain the variation that exists between the control and experimental groups regarding delayed cognitive achievement.

Further, another explanation of the variation observed between the delayed posttest scores can possibly be attributed to Electricity in Agriculture and Small Power Units/Turf Grass students' ability to transfer short-term memories to long-term memories. The results seem to indicate that reflection is beneficial to students' working memory, but does not affect long-students term-memory. According to Willingham, (2009) such result may be attributed to students' cognitive limits or the complexity of the material.

Nevertheless, because there exists a discrepancy in the delayed posttest data, it is recommended that additional research be conducted to determine how reflection consistently affect students delayed cognitive achievement. Future research should focus on how critical reflection can help transform information from short term memory to long term memory.

## **Summary**

Overall, the results of this study provide some insights into the effectiveness of reflection on students' immediate cognitive achievement. The participants' in the individual and group reflection experimental groups possessed higher immediate posttest scores than those participants' in the control group. In contrast, the results for the delayed posttests varied. In experiments two, three and four had higher delayed posttest scores than did one or both reflection groups. Based on the findings of this study, lab instructors and professors may find it beneficial to students' immediate achievement if students are prompted to reflect after a laboratory experience. However,



additional research is needed to further explore the effects of reflection on students' delayed cognitive achievement in agricultural mechanization laboratories. In addition, research is needed to identify effective instructional practices that promote long term learning from laboratory and other experiential learning activities.

## References

- Abdulwahed, M., & Nagy, Z. (2009). Applying Kolb's experiential learning cycle for laboratory education. *Journal of Engineering Education*, 98(3), 283-294. doi:10.1002/j.2168-9830.2009.tb01025.x
- Aben, B., Stapert, S., & Blokland, A. (2012). About the distinction between working memory and short-term memory. *Frontiers in Psychology*, 3 doi:10.3389/fpsyg.2012.00301
- Alloway, T. P., & Copello, E. (2013). Working memory: The what, the why, and the how. *The Australian Educational and Developmental Psychologist*, 30(2), 105. doi:10.1017/edp.2013.13
- Ash, S., & Clayton, P. (2009). *Learning through critical reflection: a tutorial for service-learning students*. NC: Raleigh.
- Atkins, S., & Murphy, K. (1993 ). Reflection: a review of the literature . *Journal of Advanced Nursing*, 18(8), 1188-1192.
- Baker, M. A., Robinson, J. S., & Kolb, D. A. (2012). Aligning kolb's experiential learning theory with a comprehensive agricultural education model. *Journal of Agricultural Education*, 53(4), 1-16. doi:10.5032/jae.2012.04001
- Bergsteiner, H., Avery, G., & Neumann, R. (2010). Kolb's experiential learning model: critique from a modelling perspective. *Studies in Continuing Education*, 32(1), 29-46. doi:10.1080/01580370903534355
- Bubnys, R., & Zydziunaite, V. (2010). Reflective learning models in the context of higher education: Concept analysis . *Problems of Education in the 21st Century* , 58-70.
- Campbell, D. T., & Julian, S. (1963). *Experimental and quasi-experimental designs for research*. Boston: Houghton Mifflin Company.
- Cano, J. (2005). Creating experiential learning. *The Agricultural Education Magazine*, 78(2), 2.
- Carver, R. L., & Enfield, R. P. (2006). John dewey's philosophy of education is alive and well. *Education and Culture*, 22(1), 55-67. doi:10.1353/eac.2006.0003
- Christensen, L. (1984). *Experimental Methodology*. Boston: Allyn and Bacon .
- Cohen, J.,(1998). *Statistical power analysis for the behavioral sciences* (Revis ed.). New York: Academic Press
- Coulson, D., & Marina, H. (2013). Scaffolding student reflection for experience-based learning: A framework. *Teaching In Higher Education*, 18(4), 401-413. doi:10.1080/13562517.2012.752726
- Cowan, N. (2008). What are the differences between long-term, short-term, and working memory? (pp. 323-338). *Amsterdam: Elsevier Science* . doi:10.1016/S0079-6123(07)00020-9

- Cozby, P., & Bates, S. (2015). *Methods in behavioral research* (5th ed.). New York City, New York : McGraw-Hill Education.
- Deslauriers, J., Rudd, R., Westfall-Rud, D., & Splan, R. (2016). The critical need for merging educational learning theories with experiential learning programs in animal agriculture: A literature review. *NACTA Journal*, 60(3), 307-312.
- Dewey, J. (1910). *How we think*. Boston: D.C.Heath & Co.
- Dewey, J. (1938). *Experience and education*. New York: Kappa Delta Pi.
- Dole, J. A., & Sinatra, G. M. (1998). Reconceptualizing change in the cognitive construction of knowledge. *Educational Psychologist*, 33(2-3), 109-128.
- Doolittle, P., & Camp, W. G. (1999). Constructivism: the career and technical education perspective. *Journal of Career and Technical Education*, 16(1).
- Ewing, J. C. (2005). Agricultural education laboratories and experiential learning. *The Agricultural Education Magazine*, 78(3), 9.
- Flannelly, K. J., Flannelly, L. T., & Jankowski, R. B. (2018). Threats to the internal validity of experimental and quasi-experimental research in healthcare. *Journal of Health Care Chaplaincy*, 24(3)1-24.doi: 10.1080/08854726.2017.1421019
- Flower, R. B., & Haddad, B. M. (2014). *Reawakening the public research university*. Santa Cruz: Authors.
- Forcino, F. L. (2013). The importance of a laboratory section on student learning outcomes in a university introductory earth science course. *Journal of Geoscience Education*, 61(2), 213-221. doi:10.5408/12-412.1
- Graham, C. M., & Craig, E. M. (2018). Supervision of school-based, agricultural education: A historical review. *Journal of Research in Technical Careers*, 2(1), 42-51.
- Harper, J. G. (1995). Experts' opinions concerning the agricultural engineering technology/mechanization component of teacher education in agriculture. *Applied Engineering in Agriculture*, 11(1), 31-35. doi:10.13031/2013.25713
- Hillison, J. (1996). Agricultural education and cooperative extension: The early agreements. *Journal of Agricultural Education*, 37(1), 9-14. doi:10.5032/jae.1996.01009
- Hofstein, A. (2004). The laboratory in chemistry education: thirty years of experience with developments, implements, and research. *Chemistry Education Research and Practice*, 5(3), 247-264.
- Hofstein, A., & Lunetta, V. N. (1982). The role of the laboratory in science teaching: Neglected aspects of research. *Review of Educational Research*, 52(2), 201.

- Johnson, D. M., Wardlow, G. W., & Franklin, T. D. (1998). Method of reinforcement and student gender: Effects on achievement in agriscience education. *Journal of Agricultural Education*, 39(4), 18-27. doi:10.5032/jae.1998.0401
- Johnson, D. M., & Schumacher, L. (1989). Agricultural mechanics specialist identification and evaluation of agricultural mechanics laboratory management competencies: a modified delphi approach. *Journal of Agricultural Education*, 30(3), 23-27.
- Johnson, D. M., Schumacher, L. G., & Stewart, B. R. (1990). An analysis of the agricultural mechanics laboratory management inservice needs of missouri agriculture teachers. *Journal of Agricultural Education*, 35-39. doi:10.5032/jae.1990.02035
- Kayes, D. C. (2002). Experiential learning and its critics: Preserving the role of experience in management learning and education. *Academy of Management Learning and Education*, 1(2), 137-149. doi:10.5465/AMLE.2002.8509336
- Knobloch, N. A. (2003). Is experiential learning authentic? *Journal of Agricultural Education*, 44(4), 22-34. doi:10.5032/jae.2003.04022
- Koch, R. J. (2010). *Technology-Enhanced Instruction: effects on Agriculture Student Cognitive Achievement At The Secondary Level*. Fayetteville : University of Arkansas, The United States of America.
- Kolb, D. (1984). *Experiential learning: experience as the source of learning and development*. Englewood Cliffs, New Jersey: Prentice Hall.
- Laken, D. (2013). Calculating and reporting effect sizes to facilitate cumulative science : A practical primer for t-tests and ANOVAs. *Frontiers in Psychology*, 4(1), 1-35. doi:10.3389/fpsyg.2013.00863
- Louise, A. (2010). Twelve tips for teaching reflection at all levels of medical education. *Medical Teacher*, 33(3), 1-6. doi:10.3109/0142159X.2010.507714
- Marlow, M. P., & McLain, B. (2011). Assessing the impacts of experiential learning on teacher classroom practice. *Research in Higher Education Journal*, 14, 1-15.
- Martin, J., & Sugarman, J. (1997). The social-cognitive construction of psychotherapeutic change: Bridging social constructionism and cognitive constructivism. *Educational Publishing Foundation*, 1(4), 375-388. doi:10.1037/1089-2680.1.4.375-388
- Mazurkewicz, M., Harder, A., & Roberts, T. (2012). Evidence for experiential learning in undergraduate teaching farm courses. *Journal of Agricultural Education*, 53(1), 176-189. doi:10.5032/jae.2012.01176
- McKim, A. J., Greenhaw, L., Carla, J., Redwine, T., & McCubbins, O. (2017). Emerging opportunities for interdisciplinary application of experiential learning among colleges and teachers of agriculture. *NACTA Journal*, 61(4), 310-316.

- Miller, J., & Hilaire, P. (2018). Enhancing agricultural classroom and lab experiences: concepts from Kolb's model of experiential learning. *Conference on Innovation In Agricultural Education* (pp. 42-43). Petionville: Feed the Future.
- Mowen, D., & Harder, A. (2005). Student learning as a result of experiential education. *The Agricultural Education Magazine*, 78(3), 6-8.
- National Research Council. (2009). *Transforming agricultural education for a changing world*. Washington D.C: National Academics Press. doi:doi:10.17226/12602
- Newsome, L. (2004). *The effect of lecture versus experiential method on cognitive achievement and attitude of agriscience students*. Fayetteville: University of Arkansas, The United States of America.
- Nguyen, Q. D., Fernandez, N., Karsenti, T., & Charlin, B. (2014). What is reflection? A conceptual analysis of major definitions and a proposal of a five-component model. *Medical Education*, 48(12), 1176-1189. doi:10.1111/medu.12583
- Paas, F., & Ayres, P. (2014). Cognitive load theory: A broader view on the role of memory in learning and education. *Educational Psychology Review*, 26(2), 191-195. doi:10.1007/s10648-014-9263-5
- Public Law No. 347, 64th Congress 703, Smith-Huges Act (1917). Retrieved April 27, 2019, from <https://files.eric.ed.gov/fulltext/ED055205.pdf>
- Rekart, J. (2013). *The cognitive classroom: Using brain and cognitive science to optimize student success*. Lanham: Rowman & Littlefield Publishers, Inc .
- Reed, S. K. (1996). *Cognition: theory and applications*. Monterey, Calif: Brooks/Cole Pub. Co.
- Roberts, T.G.. (2006). A philosophical examination of experiential learning theory for agricultural educators. *Journal of Agricultural Education*, 47(1), 17-29. doi:10.5032/jae.2006.01017
- Roberts, T. G., Harder, A., & Brashears, M. T. (Eds). (2016). *American Association for Agricultural Education national research agenda: 2016-2020*. Gainesville, FL: Department of Agricultural Education and Communication.
- Rudolph, J. L. (2005). Epistemology for the masses: The origins of "the scientific method" in American schools. *History of Education Quarterly*, 45(3), 341-376.
- Salavastru, D. (2014). Experiential learning and the pedagogy of interrogation in the education of adults. *Procedia Social and Behaviroal Sciences*, 14, 548-552. doi:10.1016/j.sbspro.2014.07.664
- Sandars, J. (2009). The use of reflection in medical education: AMEE guide no. *Medical Teacher*, 685-695. doi:10.1080/01421590903050374

- Sharit, J., & Czaja, S. J. (2018). Overcoming older adult barriers to learning through an understanding of perspectives on human information processing. *Journal of Applied*, doi:733464818794574.
- Shelley-Tolbert, C. A., Conroy, C. A., & Dailey, A. L. (2000). The move to agriscience and its impact on teacher education in agriculture. *Journal of Agricultural Education. Journal of Agricultural Education*, 41(4), 51-61. doi:10.5032/jae.2000.04051
- Shinn, G. C. (1998). Transforming agricultural mechanics curriculum through expert opinion to model technologies in food, environmental, and natural resource systems. New Orleans: American Vocational Association Convention.
- Shoulders, C. W., Wyatt, J. D., & Johnson, D. M. (2014). Demonstrations and lectures about solar energy in Arkansas" importance of experiential learning. *Elsevier: Energy Research & Social Science*, 4, 100-105. doi: 10.1016/j.erss.2014.10.002
- Shoulders, C. W., & Myers, B. E. (2013). Teachers' use of experiential learning stages in agricultural laboratories. *Journal of Agricultural Education*, 100-115. doi:0.5032/jae.2013.03100
- Squire, L. R., & Zola, S. M. (1996). Structure and function of declarative and nondeclarative memory systems. *Proceedings of the National Academy of Sciences of the United States of America*, 93(24), 13515-13522. doi:10.1073/pnas.93.24.13515
- Surls, R. (2014). *Smith-Lever Act creation of cooperative extension*. Retrieved from University of California Division of Agriculture and Natural Resources:
- True, A. C. (1929). *A history of agricultural education in the united states 1785-1925*. Washington: United States Department of Agriculture Miscellaneous Publication No.36.
- Warner, W. J., Arnold, S., Jones, D. W., & M, M. B. (2006). The use and design of laboratory instruction in secondary agriscience classrooms . *Journal of Southern Agricultural Education Research* , 125-135.
- Willingham, D. (2009). *Why don't students like school?: A cognitive scientist answers questions about how mind works and what it means for your classrrom* . San Francisco, California : Jossey-Bass .

## Appendices

### Appendix A Institutional Review Board Letter of Approval



---

**To:** Patterson Perez Hilaire  
BELL 4188

**From:** Douglas James Adams, Chair  
IRB Committee

**Date:** 01/24/2019

**Action:** **Exemption Granted**

**Action Date:** 01/24/2019

**Protocol #:** 1809145873

**Study Title:** Evaluating the effects of different reflection methods on students cognitive achievement, retention and attitude in Agricultural Mechanization

The above-referenced protocol has been determined to be exempt.

If you wish to make any modifications in the approved protocol that may affect the level of risk to your participants, you must seek approval prior to implementing those changes. All modifications must provide sufficient detail to assess the impact of the change.

If you have any questions or need any assistance from the IRB, please contact the IRB Coordinator at 109 MLKG Building, 5-2208, or [irb@uark.edu](mailto:irb@uark.edu).

cc: Donald M Johnson, Investigator

Appendix B

**Experiment One**  
**Individual/ Group Reflection Module For AC Resistive Circuits**

**AGME 3170 L**  
**Electricity in Agriculture**  
**Individual Reflection Module**

**Instructions:** The purpose of this reflection module is to help you describe and process your laboratory experience. Take a few minutes to go through the reflection individually and provide honest feedback in the space provided. Remember that this reflection will not affect your laboratory grade. This reflection module is based on the D.E.A.L model which requires students to critically reflect through describing, examining, and articulating what they learned from a previous experience.

**Step 1.**  
**Describe**

Question	Response
Based on your lab, you know you need a power source, a conductor, and a load connected to a continuous conducting path to form a circuit. In the space provided, draw a schematic that would represent a circuit.	
How can you use what you have learned in today's lab in a real-world setting?	



## Step 2 Examination

The picture below (Figure 1.) can be used as an analogy for the principles of electricity. How can the principles of electricity relate to the pressure, flow, and restriction of water represented in the schematics below?

Pressure compares to \_\_\_\_\_

Flow compares to \_\_\_\_\_

Pipe Friction compares to \_\_\_\_\_

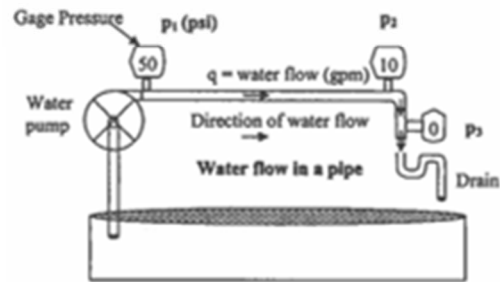

Figure 1. (Gustafson & Morgan, 2004)

In the picture below, the lightbulb (loads) are connected in-line with the source and with each other. This type of circuit is known as a series circuit. If this circuit is energized and a complete closed circuit is made, what would happen to the circuit if one lightbulb is removed? What would happen the other lights?

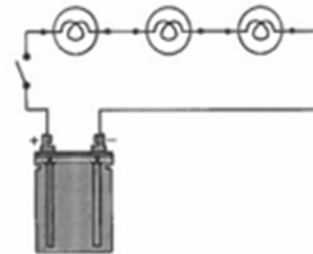

Figure 2. (Abdo, 2011)

Based on your lab experience, would each load have the same current flow (amperage) in the circuit above?

In the parallel circuit below electrons “split” at the terminals and the three loads and then recombine at the second terminal and then flows back to the source. The voltage in this circuit remains the same and is equal across each load. If you remove one lightbulb (load) from the circuit below, what would happen to the other lightbulbs (loads) if the circuit is fully energized and operating? What would happen to the circuit?

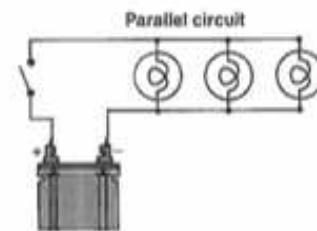

Figure 2. (Abdo, 2011)

An AGME student below is making an electrical measurement in the circuit pictured below. The meter dial was “turned” to the electrical symbol:  $\Omega$  and the conductors and load had to be disconnected from the power source. Do you remember performing this procedure? What electrical measurement did you record? Did you have any challenges in performing this procedure?





## Step 2. Examination

When an inductor (coil or motor) is introduced to an AC circuit, the inductor opposes current change in the circuit. This "counterforce" causes current to \_\_\_\_\_ the voltage. The opposite is true for AC circuits with capacitors. How can you use the acronym below to fill in the blank above? (*hint*: remember E= volts, I=amps).

ELI the ICE man

---



---



---

A student is describing a circuit. He says in an AC circuit, when elements such as a **capacitors** or **inductors** are introduced, **current** and **voltage** become out of sync with each other (does not reach peak current and voltage at the same time). He then says the **degrees difference** between the two is known as something he can't remember at the moment. The student performs the following calculations on two separate motors, A and B. Although both motors have the same power ratings (apparent power kVA), he realize one motor uses power more inefficiently than the other (reactive power kVar). This means that one motor is using more power than it needs (drawing more current and not actually using it). What is the word/concept the student could not remember? What major factor(s) causes the difference in the efficiency in using power?



Output: 8kW  
Voltage: 220  
PF: .72  
**Motor A**

$$\text{Apparent power (kVA)} = \text{kW} \div \text{PF}$$

$$8\text{kW} \div .72 = 11.11\text{kVA}$$

$$\text{Reactive Power (kVar)} = \sqrt{\text{kVA}^2 - \text{kW}^2}$$

$$= \sqrt{11.11\text{kVA}^2 - 8\text{kW}^2}$$

$$= 5.7\text{kVar}$$



Output: 8kW  
Voltage: 220  
PF: .95  
**Motor B**

$$\text{Apparent power (kVA)} = \text{kW} \div \text{PF}$$

$$8\text{kW} \div .95 = 8.42\text{kVA}$$

$$\text{Reactive Power (kVar)} = \sqrt{\text{kVA}^2 - \text{kW}^2}$$

$$= \sqrt{8.42\text{kVA}^2 - 8\text{kW}^2}$$

$$= 2.62\text{kVar}$$

**Step 3.  
Articulate Learning**

Mark operates a small grain processing plant and has several of the motors listed above in operation at his plant. Last week, Mark received a notice from his electrical producer indicating his electrical rate is going to increase because of a transmission adjustment was made to accommodate the motors at his grain processing plant. Mark wants to avoid this upcharge. What electrical component can Mark add to his electrical system to ensure his system runs it little more efficiently and subsequently avoid this upcharge? Why? Would you advise him to keep the same motors? Why?

---

---

---

## Appendix D

### Experiment Three Reflection Module for Carburetor Systems

#### AGME 3101L Service and Repair Carburetor Systems Individual Reflection

**Instructions:** The purpose of this reflection module is to help you describe and process your previous laboratory experience. Take a few minutes to go through the module, and provide yourself clear and honest feedback. Remember that this reflection module will not affect your laboratory grade. This reflection module is based on the D.E.A.L model which requires students to critically reflect through describing, examining and articulating what they learned from an experience.

#### Step 1. Describe

Question	Response
What is the purpose of a carburetor?	
What do the float and inlet needle valve do in a carburetor?	

A student makes the following statement (Box 1) about how a venturi works on a carburetor. Evaluate the student's statement to see whether it is valid statement or not. (Provide reasons of why the student may be right or wrong.)

*Box 1*

*"When there is a smaller area for air to pass through or a narrowed down section of a passageway, the air increases in speed which causes a decrease in pressure, and it is this decrease in pressure that causes fuel to be drawn into the high speed air. When the fuel reaches the high speed air, it atomizes and is "sprayed" into the combustion chamber."*

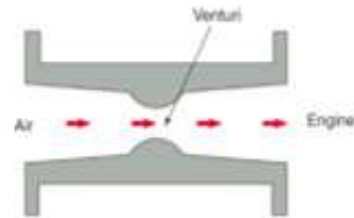

Figure 3 (Abdo, 2011)

### Step 3 Articulate Learning

Your friend left their lawnmower over the winter in the shed and they forgot to drain the fuel from the tank and carburetor. As a result, the fuel “drew” moisture into the carburetor and clogged all the carburetor jets. Your friend decides to service the carburetor and has completely disassembled it as pictured in figure 4 below. Your friend wants to know the purpose of the choke, throttle, and float on their carburetor. **Describe to your friend the purpose** of these listed components. Also, your friend is confused on which side the choke and throttle should be installed on the carburetor. **Explain** to your friend which side is the “choke and throttle side” of the carburetor.

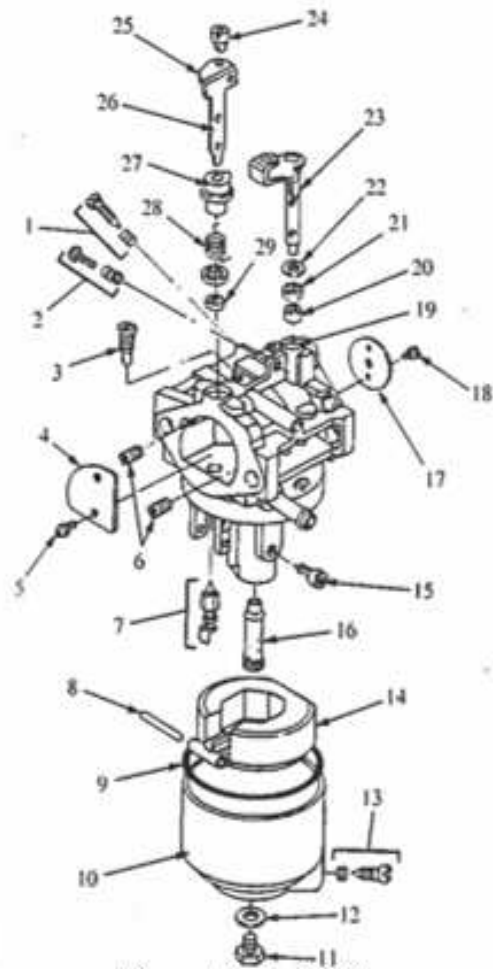

Figure 4 (Roth, 2004)



Appendix E

**Experiment Four**  
**Individual/ Group Reflection Module for Ignition Systems**

**AGME 3101L**  
**Ignition Systems**  
**Group Reflection**

**Instructions:** The purpose of this reflection unit is to help you describe and process your previous laboratory experience. Take a few minutes to go through the module individually and then as a group, and provide honest feedback in the space provided. Remember that this reflection module will not affect your laboratory grade. Finally, this reflection module is based on the D.E.A.L model which requires students to critically reflect through **describing, examining, and articulating** what they have learned from a previous experience.

**Step 1.**  
**Describe**

<b>Question</b>	<b>Response</b>
What is the sole purpose of an ignition system?	
List the components of a magneto type ignition system.	

## Step 2 Examination

The picture below (Figure 1.) can be used as an analogy for the principles of electricity. How can the principles of electricity relate to the pressure, flow, and restriction of water represented in the schematics below?

Pressure compares to \_\_\_\_\_

Flow compares to \_\_\_\_\_

Pipe Friction compares to \_\_\_\_\_

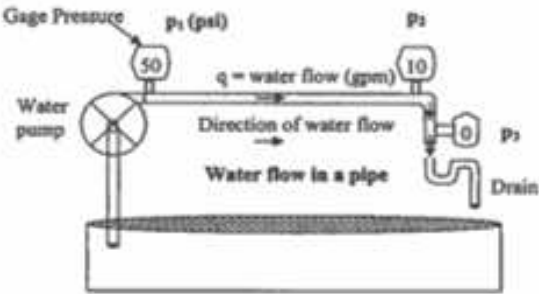

Figure 1. (Gustafson & Morgan, 2004)

Figure 2 is depicting an adjustment procedure for an ignitions system on a small power unit. What procedure do you think is being performing? Why is this procedure important? What is the purpose of the part label A?

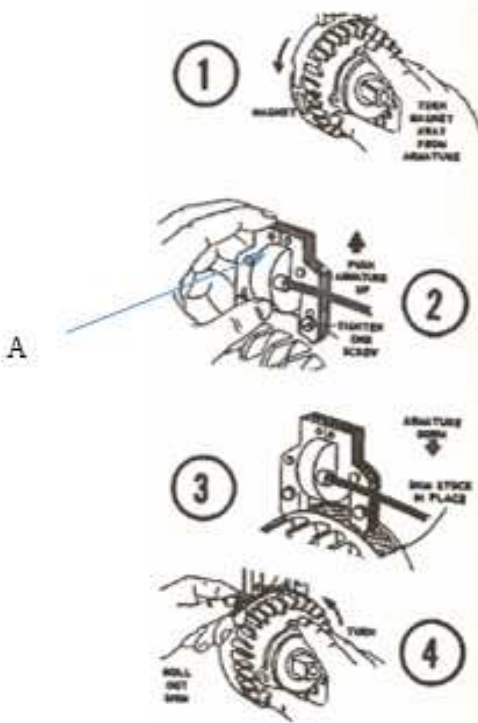

Figure 2 (Technical Publications, 1983)

One of the principles of electricity state when current flows through a conductor (Figure 3), a magnetic field is produced. With this understanding and your lab experience, describe the force being produced in figure 4. How does this relate to an ignition system? What would the light represent in an ignition system? What ignition component does this rotating magnet represent?



Figure 3 (Abdo 2011)

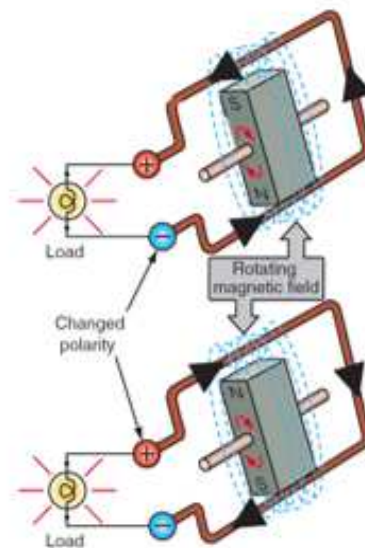

Figure 4 (Abdo, 2011)

A single cylinder four stroke engine that has an rpm of 2000 requires \_\_\_\_\_ number of spark per revolution. In reality, however, the engine produces \_\_\_\_\_ number of sparks at 2000 rpm's.

### Step 3 Articulate Learning

A friend of yours was not able to make it to today's laboratory. Your friend anxiously wants to know the difference between a breaker point ignition system and a solid state ignition system. In order to help your friend, provide a brief description comparing and contrasting a breaker point ignition system and solid state ignition system. How can your friend identify and distinguish between a breaker point and solid state ignition system?

## Appendix F

### Experiment Five Individual/ Group Reflection Module for Electrical Motors in Agriculture

#### AGME 3170 L Electricity in Agriculture Group Reflection Module

**Instructions:** The purpose of this reflection unit is to help you describe and process your previous laboratory experience. Take a few minutes to go through the module individually and then as a group, and provide honest feedback in the space provided. Remember that this reflection module will not affect your laboratory grade. Finally, this reflection module is based on the D.E.A.L. model which requires students to critically reflect through **describing**, **examining**, and **articulating** what they have learned from a previous experience.

#### Step 1. Describe

What are six pieces of information found on an electrical motor name plate?

Premature motor failure is common in agricultural applications. What factor on the nameplate indicates the maximum overload an electrical motor can sustain? Give an example from the lab, and interpret the example (explain what it means).

## Step 2. Examination

It is recommended that on a dual voltage motor that the motor should always be wired to the highest voltage when possible. What is the advantage of doing this?

A motor should not be wired to a voltage source that is lower than its listed voltage. Why is this important to remember? (hint: remember the power watts formula).

What would happen to a motor if the starting windings are not disconnected when the motor reaches 75% of its full speed?

The characteristics of a three-phase motor make it inherently self-starting. How do the same characteristics help in reversing the rotation of three-phase motor?

Examine the diagram below. Is it possible to tell if the schematics below represent a single-phase or three phase motor? How could you tell?

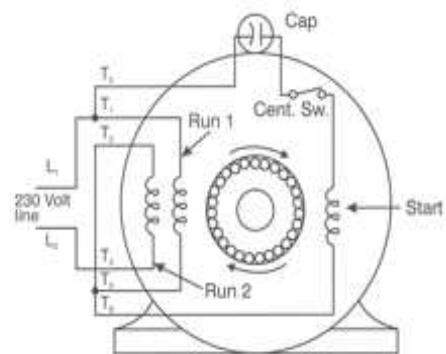

Is the motor pictured above wired for high or low voltage?

### Step 3. Articulate Learning

A friend of yours has a backyard organic grain processing plant. His small business is growing and because of this, he wants to replace his hand crank grain processing machine with a motor and pulley system in order to process more grain. He is trying to select a motor, and he needs your advice. What electrical motor and enclosure type would you recommend to your friend? What additional advice would you give him regarding motor selection?



## Appendix G

### AC Resistive Circuits Immediate and Delayed Posttests

**AGME 3170 L**  
**Electricity in Agriculture**  
**Laboratory Activity: Electrical Measurement**  
**Posttest**

1. \_\_\_\_\_ are the unit of measurement for the flow of electrons in a circuit.
  - a. Volts
  - b. Watts
  - c. Amperes
  - d. Resistance
  
2. \_\_\_\_\_ are the unit of measurement for the amount of electrical pressure.
  - a. Volts
  - b. Watts
  - c. Amperes
  - d. Resistance
  
3. A Circuit can be defined as:
  - a. an electromagnet inducing element with resistance
  - b. an element that that resist the movement of electrons
  - c. a closed continuous conducting path
  - d. a measure of voltage across an electrical device
  
4. A series circuit can be defined as:
  - a. A circuit that has the source and resistive elements joined together in an end to end single loop.
  - b. A circuit that has two subsections between conductors and resistors.
  - c. A circuit that has its sources and resistive elements joined together between a single pair of terminals.
  - d. A circuit that has equal voltage across each load.
  
5. A parallel circuit can be defined as:
  - a. A circuit that has the source and resistive elements joined together in an end to end single loop.
  - b. A circuit that has two subsections between conductors and resistors.
  - c. A circuit that has its sources and resistive elements joined together between a single pair of terminals.
  - d. A circuit that has equal voltage across each load.
  
6. Current (electron flow) is \_\_\_\_\_ across each element in a series circuit.
  - a. Indirectly Proportional
  - b. Directly Proportional
  - c. Equal
  - d. Different

7. A series circuit has three resistors that totals to a combine resistance of 60 ohms. The circuit also has a sources voltage of 120v. What is the current (amperage) in each resistor?
- 60
  - 12
  - 2
  - 5
8. Circle the statement that is **NOT** one of the governing principles of a simple parallel circuit of resistive elements?
- Voltage across each resistor are equal.
  - Current (electron flow) divides at one terminal and recombines at the second terminal.
  - Current flow is the same in each resistor.
  - The reciprocal of total resistance is equal to the sum of the reciprocals of each of the individual resistances.
9. The first resistor in a parallel circuit is 120 ohm, the second resistor is 45 ohm and the third resistor is 360 ohm, what is the total resistance?
- 525 ohm
  - 360 ohm
  - 30 ohm
  - 45 ohm
10. A circuit/object must be de-energized in order to measure \_\_\_\_\_?
- Voltage
  - Resistance
  - Current
  - Watts

## Appendix H

### AC Circuit Analysis Immediate and Delayed Posttest

Name: \_\_\_\_\_

**AGME 3170 L**  
**Electricity in Agriculture**  
**Laboratory Activity: Electrical Measurement**  
**Posttest**

1. In an AC circuit that only has pure inductance (negligible resistance), one would expect current to \_\_\_\_\_ the voltage by  $90^\circ$ .
  - a.) frequent
  - b.) lag
  - c.) lead
  - d.) match
  
2. In an AC circuit that only has pure capacitance the current \_\_\_\_\_ the voltage by  $90^\circ$ .
  - a.) frequent
  - b.) lag
  - c.) lead
  - d.) match
  
3. Total impedance can be defined as:
  - a.) a vector sum of resistance, inductive reactance and capacitive reactance  $Z = \sqrt{R^2 + [X_L - X_C]^2}$
  - b.) the angle between the resistors (R), and total impedance (Z).
  - c.) the total current variation of one (1) ampere per second.
  - d.) the optimum amount of power transfer in an ac system.
  
4. When electrical current flows through a conductor, a/an \_\_\_\_\_ is produced.
  - a.) electrical charge
  - b.) electromotive force (emf)
  - c.) dielectric charge
  - d.) magnetic field
  
5. When a conductor is relatively moved through a magnetic field and crosses the lines of magnetic force (flux), a/an \_\_\_\_\_ is induced into the conductor.
  - a.) electrical charge
  - b.) electromotive force (emf)
  - c.) dielectric charge
  - d.) magnetic field

6. Robert Gustafson made the following calculations in the AC circuit picture below (Figure 1). What type reactance does this circuit contain?

- a.) natural reactance
- b.) capacitive reactance
- c.) inductive reactance
- d.) resistive reactance



Figure 1. (Gustafson & Morgan, 2004)

7. The angle that exist (Figure 2) between the pure resistance (R), and the total impedance, Z is known as \_\_\_\_\_.

- a.) phase shift angle
- b.) singular phase angle
- c.) cosine angle
- d.) RLC hertz angle

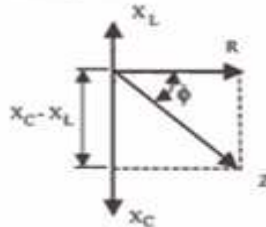

Figure 2. (Gustafson & Morgan, 2004)

8. In Figure 2 above, electrical current in the circuit is expected to \_\_\_\_\_ the voltage by 90°.

- a.) supply
- b.) impede
- c.) lag
- d.) lead

9. A Baldor Reliance electrical motor that is manufactured in Arkansas is rated at 60Hz, 1770 RPM and has power factor (p.f) .81, and a Dayton electrical motor is rated at 60Hz, 1725 RPM and has a power factor (p.f) .70. Based on the information listed, which motor would be more efficient in using power in a given circuit?

- a.) Baldor Reliance
- b.) Dayton
- c.) both Baldor Reliance and Dayton have the same power efficiency
- d.) I do not know

10. \_\_\_\_\_ can be added to electrical circuits and systems to correct for current and voltage displacements caused by coils and machines such as electrical motors.

- a.) Inductors
- b.) Capacitors
- c.) Resistors
- d.) Armatures

## Appendix I

### Carburetor Systems Immediate and Delayed Posttests

**AGME 3101L**  
**Service and Repair Carburetor Systems**  
**Quiz**  
**1 point each**

1. What is the primary function of a carburetor?
  - a. provide heat and fuel mixture to the combustion chamber
  - b. provide air-fuel mixture to the combustion chamber
  - c. compresses air-fuel mixture for the combustion stroke
  - d. converts energy to mechanical motion
  
2. A venturi can be defined as:
  - a. a restriction in a passage which causes a pressure drop and increase in air velocity
  - b. an increase in a passage that causes temperature to rise and level to rise
  - c. a restriction in a passage which causes a repulsion
  - d. I don't know
  
3. What is ONE of the risks of removing an air filter from a 6.75 hp Briggs and Stratton engine?
  - a. the throttle and choke valve will be damaged
  - b. dust or grit will be drawn into the engine cylinder
  - c. a large air gap will form and damage the carburetor jet
  - d. carburetor injectors and adjusters will be damaged
  
4. The purpose of a **closed** choke valve when starting a "cold" engine is to:
  - a. provide a rich air-fuel mixture into the combustion chamber
  - b. open the intake manifold
  - c. close the intake manifold
  - d. regulate the fuel adjustment needle
  
5. What is the primary purpose of a primer during a "cold" start?
  - a. Forces additional fuel into the combustion chamber
  - b. To create a vacuum that closes the choke valve
  - c. Increase cylinder pressure
  - d. Forces additional air into the combustion chamber

6. What is **NOT** one of the proper procedure to service a Briggs and Stratton Oil-Foam Air Filter (as prescribed by the 2003 Briggs and Stratton 2003)?
- saturate foam (air filter) with engine oil and remove any excess oil.
  - wash foam (air filter) element in liquid detergent and water
  - dry foam (air filter) with kerosene solvent
  - wrap foam in cloth and squeeze dry
7. In figure 1 pictured below, the carburetor component labeled 13 is known as \_\_\_\_\_.
- Choke valve
  - Throttle valve
  - Idle adjustment needle
  - Main Jet

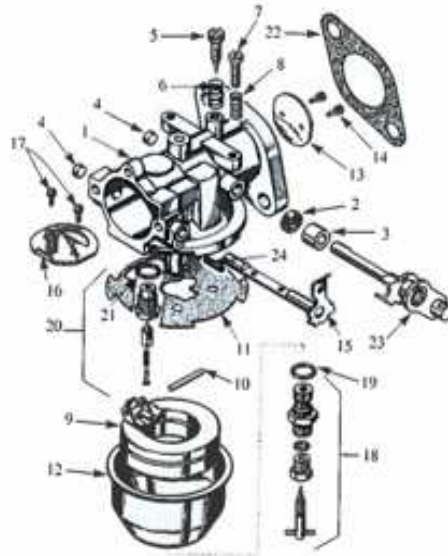

Figure 1 (Roth, 2004)

8. In the carburetor pictured above (Figure 1), the amount of fuel that enters the fuel bowl is regulated by \_\_\_\_\_.
- primer repulsion
  - heat displacement
  - the float level
  - a jet needle bar valve

**AGME 3101L**  
**Service and Repair Carburetor Systems**  
**Quiz**  
**1 point each**

1. A venturi can be defined as:
  - a. a restriction in a passage which causes a pressure drop and increase in air velocity
  - b. an increase in a passage that causes temperature to rise and level to rise
  - c. a restriction in a passage which causes a repulsion
  - d. I don't know
  
2. What is ONE of the risks of removing an air filter from a 6.75 hp Briggs and Stratton engine?
  - a. the throttle and choke valve will be damaged
  - b. dust or grit will be drawn into the engine cylinder
  - c. a large air gap will form and damage the carburetor jet
  - d. carburetor injectors and adjusters will be damaged
  
3. The purpose of a **closed** choke valve when starting a "cold" engine is to:
  - a. provide a rich air-fuel mixture into the combustion chamber
  - b. open the intake manifold
  - c. close the intake manifold
  - d. regulate the fuel adjustment needle
  
4. What is NOT one of the proper procedure to service a Briggs and Stratton Oil-Foam Air Filter (as prescribed by the 2003 Briggs and Stratton 2003)?
  - a. saturate foam (air filter) with engine oil and remove any excess oil.
  - b. wash foam (air filter) element in liquid detergent and water
  - c. dry foam (air filter) with kerosene solvent
  - d. wrap foam in cloth and squeeze dry

5. In figure 1 pictured below, the carburetor component labeled 13 is known as \_\_\_\_\_.

- a. Choke valve
- b. Throttle valve
- c. Idle adjustment needle
- d. Main Jet

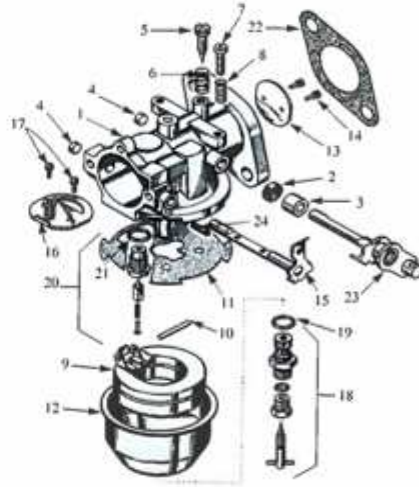

Figure 1 (Roth, 2004)



## Appendix J

### Battery and Ignition Systems Immediate and Delayed Posttests

#### AGME 3101L Ignition Systems Posttest

- 1.) \_\_\_\_\_ move across spark plug air gaps in order to produce a spark for the combustion cycle.
  - a.) cam blocks
  - b.) electrons
  - c.) voltage
  - d.) magnets
  
- 2.) \_\_\_\_\_ transforms low voltage to a high voltage in an ignition system.
  - a.) ignition coil
  - b.) battery
  - c.) breaker-points
  - d.) flywheel
  
- 3.) The clearance between the armature “legs” and the flywheel is known as:
  - a.) magnetic air gap
  - b.) breaker point leg air gap
  - c.) armature air gap
  - d.) flywheel air gap
  
- 4.) \_\_\_\_\_ are the unit of measurement for the amount of electrical pressure.
  - a.) Volts
  - b.) Watts
  - c.) Amperes
  - d.) Resistance
  
- 5.) When electrical current flows through a conductor, a/an \_\_\_\_\_ is produced.
  - a.) electrical charge
  - b.) electromotive force (emf)
  - c.) dielectric charge
  - d.) magnetic field

6.) When a conductor is moved relatively through a magnetic field and crosses the lines of magnetic force (flux), a/an \_\_\_\_\_ is induced into the conductor.

- a.) electrical charge
- b.) electromotive force (emf)
- c.) dielectric charge
- d.) magnetic field

7.) What ignition component is **NOT** part of a magneto ignition system?

- a.) condenser
- b.) permanent magnets
- c.) spark plug
- d.) battery

8.) A 6.75 hp Briggs and Stratton engine is turning at 3600 rpm, the number of spark per minute needed to maintain this speed would be

- a.) 1800 sparks/min
- b.) 30 sparks/min
- c.) 7,200 sparks/min
- d.) 3600 sparks/min

9.) When an engine is running and the magnets on the flywheel are passing by the ignition armature, the amount of voltage induced into the ignition armature is determine by \_\_\_\_\_.

- a.) condensers
- b.) breaker points
- c.) engine speed
- d.) rectifier

10.) The **main** purpose of an ignition system is to:

- a.) provide air-fuel mixture to the combustion chamber
- b.) increase pressure in the and create a vacuum in the combustion chamber
- c.) provide a spark that ignites the air-fuel mixture that is in the combustion chamber
- d.) maintain a predetermine voltage range is a charging system

11.) Which of the following statements about ignitions coils in small power equipment is **NOT** correct?

- a.) The secondary windings in the coil is connected to the spark plug
- b.) The secondary windings contains more coils of wire than the primary windings
- c.) Ignitions systems have two power source options, a battery or AC generator
- d.) Magneto ignitions systems operate with a battery

12.) Figure 1 depicts an example of what type of ignition system?

- a.) repulsion ignition system
- b.) battery ignition system
- c.) breaker point ignition system
- d.) solid-state ignition system

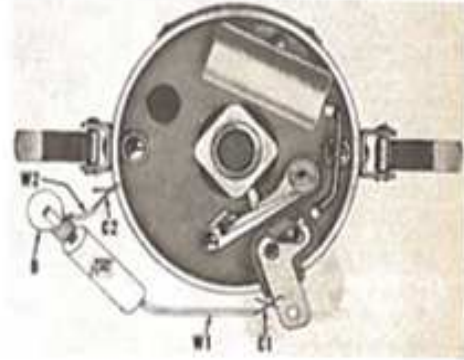

**AGME 3101L**  
**Ignition Systems**  
**Posttest 2**

1. \_\_\_\_\_ are the unit of measurement for the amount of electrical pressure.
  - a) Volts
  - b) Watts
  - c) Amperes
  - d) Resistance
  
- 2.) When electrical current flows through a conductor, a/an \_\_\_\_\_ is produced.
  - a) electrical charge
  - b) electromotive force (emf)
  - c) dielectric charge
  - d) magnetic field
  
- 3.) What ignition component is NOT part of a magneto ignition system?
  - a) condenser
  - b) permanent magnets
  - c) spark plug
  - d) battery
  
- 4.) When an engine is running and the magnets on the flywheel are passing by the ignition armature, the amount of voltage induced into the ignition armature is determine by \_\_\_\_\_.
  - a) condensers
  - b) breaker points
  - c) engine speed
  - d) rectifier

5.) Which of the following statements about ignitions coils in small power equipment is **NOT** correct?

- a) The secondary windings in the coil is connected to the spark plug
- b) The secondary windings contains more coils of wire than the primary windings
- c) Ignitions systems have two power source options, a battery or AC generator
- d) Magneto ignitions systems operate with a battery

6.) Figure 1 depicts an example of what type of ignition system?

- a) repulsion ignition system
- b) battery ignition system
- c) breaker point ignition system
- d) solid-state ignition system



Figure 1 (Technical Publications, 1983)

## Appendix K

### Electrical Motors in Agriculture Immediate and Delayed Posttests

**AGME 3173**  
**Electricity in Agriculture**  
**Laboratory Activity**  
**Electric Motors: Types, Enclosures, Nameplates, and Wiring**  
**Quiz**

1. An electric motor has 10 hp, 3600 RPM and SF of 1.15 listed on its name plate. What is the maximum continuous load the listed motor can safely handle?
  - a. 1.15
  - b. 1.25
  - c. 11.5
  - d. 12.5
  
2. \_\_\_\_\_ is the letter that signifies the motors starting requirement.
  - a. Power Factor
  - b. Service Factor
  - c. Frame Designation
  - d. Motor Code
  
3. What is **NOT** one of the factors that commonly contribute to electric motor failure?
  - a. loads that exceeds maximum overload of motors
  - b. dual capacitors configurations
  - c. excessive current flow in motor windings
  - d. inadequate motor ventilation
  
4. The schematics of a dual-voltage motor is pictured below. Complete the circuit on the schematic so that the motor is wired for **high-voltage** operation.

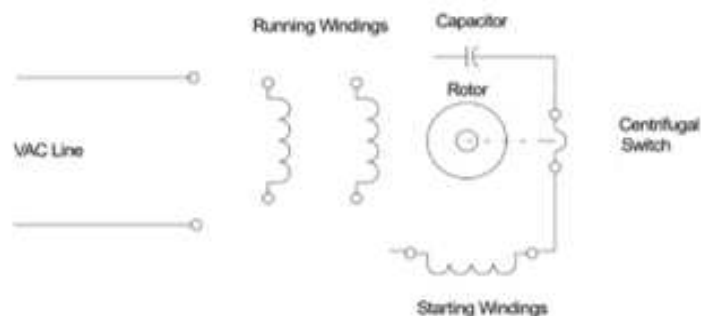

5. In an single phase electrical motor, a(an) \_\_\_\_\_ is typically wired in series with an starting windings in order to deactivate the starting windings once the has motor reached 75% of full speed.
- a. centrifugal switch
  - b. repulsion switch
  - c. DC switch
  - d. delta phase switch
6. What would happen to a single-phase motor if the starting windings failed to deactivate when the motor reaches full speed?
- a. motor will overheat
  - b. starting windings will overheat
  - c. premature motor failure
  - d. all of the above
7. The motor depicted below falls under which category of motor enclosures?
- a. drip proof
  - b. open
  - c. totally enclosed
  - d. explosion proof



8. \_\_\_\_\_ type of motors would be suited for damp areas but AND dusty areas.
- a. drip proof
  - b. open
  - c. totally enclosed
  - d. explosion proof

9. How would you reverse the rotation of the three-phase motor below?
- wire "wild-leg" in series to starting windings
  - wire "wild leg" in parallel to any
  - reverse the connection of any two of the three power lines
  - wire a centrifugal switch in series with the starting windings
10. A single-phase motor that has a rated operational voltage of 230v will draw \_\_\_\_\_ current (amps) in the running windings if it connected to a 208v source?
- more
  - less
  - indefinite
  - controlled
11. Which of the following is **NOT** a characteristic of a three-phase motor?
- inherently self-starting
  - possess an starting windings
  - motor current in each winding are 120 degrees out of phase with the other windings
  - three phase motor windings can either be wye or delta connected
12. When the running windings of a motor are wired in series, it is wired for \_\_\_\_\_ voltage operation.
- high
  - low
  - switch
  - torque



**AGME 3173**  
**Electricity in Agriculture**  
**Laboratory Activity**  
**Electric Motors: Types, Enclosures, Nameplates, and Wiring**  
**Quiz**

1. An electric motor has 10 hp, 3600 RPM and SF of 1.15 listed on its name plate. What is the maximum continuous load the listed motor can safely handle?
  - a.) 1.15
  - b.) 1.25
  - c.) 11.5
  - d.) 12.5
  
2. What is **NOT** one of the factors that commonly contribute to electric motor failure?
  - a.) loads that exceeds maximum overload of motors
  - b.) dual capacitors configurations
  - c.) excessive current flow in motor windings
  - d.) inadequate motor ventilation
  
3. In a single phase electrical motor, a(an) \_\_\_\_\_ is typically wired in series with an starting windings in order to deactivate the starting windings once the motor has reached 75% of full speed.
  - a.) centrifugal switch
  - b.) repulsion switch
  - c.) DC switch
  - d.) delta phase switch
  
4. How would you reverse the rotation of the three-phase motor below?
  - a.) wire "wild-leg" in series to starting windings
  - b.) wire "wild leg" in parallel to any
  - c.) reverse the connection of any two of the three power lines
  - d.) wire a centrifugal switch in series with the starting windings

5. Which of the following is **NOT** a characteristic of a three-phase motor?
- a.) inherently self-starting
  - b.) possess an starting windings
  - c.) motor current in each winding are 120 degrees out of phase with the other windings
  - d.) three phase motor windings can either be wye or delta connected
6. When the running windings of a motor are wired in series, it is wired for \_\_\_\_\_ voltage operation.
- a.) high
  - b.) low
  - c.) switch
  - d.) torque