

University of Arkansas, Fayetteville

ScholarWorks@UARK

Mechanical Engineering Undergraduate Honors
Theses

Mechanical Engineering

5-2019

Design of a SCARA Based Mobile 3D Printing Platform

Zachary Hyden

Follow this and additional works at: <https://scholarworks.uark.edu/meeguht>



Part of the [Electro-Mechanical Systems Commons](#), and the [Manufacturing Commons](#)

Citation

Hyden, Z. (2019). Design of a SCARA Based Mobile 3D Printing Platform. *Mechanical Engineering Undergraduate Honors Theses* Retrieved from <https://scholarworks.uark.edu/meeguht/84>

This Thesis is brought to you for free and open access by the Mechanical Engineering at ScholarWorks@UARK. It has been accepted for inclusion in Mechanical Engineering Undergraduate Honors Theses by an authorized administrator of ScholarWorks@UARK. For more information, please contact scholar@uark.edu.

Design of a SCARA Based Mobile 3D Printing Platform

A Thesis Presented by

Zachary Hyden

April 2019

University of Arkansas

X

Wenchao Zhou, Ph.D.
Thesis Advisor

X

David Jensen, Ph.D.
Committee Member

Acknowledgements

I would like to thank Dr. Wenchao Zhou for the opportunity to work on this project and for his help throughout the process. Next I would like to thank Lucas Galvan Marques and Robert Austin Williams for the tremendous amount of work they have put in on the circuits and software of this research, without them this would not have been possible. Finally I would like to thank the University of Arkansas and the Mechanical Engineering Department for funding this research and making it all happen.

Abstract

Currently 3D printers rely heavily on people to run them, there is no automatic way to start a new print after one has finished. On top of this 3D printers are limited in the area they can print on. Even though the additive manufacturing market is rapidly growing and is increasingly being used in product manufacturing there has yet to be a solution to this problem. This research proposes using mobile 3D printing robots to solve both of these issues. The proposed prototype utilizes a Selective Compliance Assembly Robot Arm (SCARA) based robot capable of cooperatively manufacturing parts. This allows for multiple robots to build single parts, decreasing the time taken for 3D printing and allowing for multiple materials to be used. With the robots being mobile it allows for multiple prints to be done consecutively without the need for human input. The design shown here features a fused deposition modeling (FDM) tool-head. In this research a concept was designed and realized through a prototype and subsequent evaluation. From the evaluation of this prototype design, knowledge was gained to be used in the design of a production version at a later date.

List of Figures

Figure 1-1: Intermediate Prototype Design.....	9
Figure 1-2: Picture of v5 prototype with text bubbles to identify systems.....	10
Figure 2-1: Tool-End Z-Axis [6]	13
Figure 2-2: (a) Average Commercial SCARA Motion Range (b) Required Motion Range	13
Figure 3-1: Previous Designs (a) Version 1 (b) Version 2 (c) Version 3 (d) Version 4.....	15
Figure 3-2: Mobile Printing Platform and System Breakdown	16
Figure 3-3: SCARA Breakdown.....	17
Figure 3-4: Chassis Design (a) initial (b) final	18
Figure 3-5: Robot Mobile Platform Breakdown.....	19
Figure 3-6: Floor Tile Design Breakdown.....	20
Figure 3-7: Floor Tile Design (a) top (b) Bottom.....	20
Figure 3-8: Floor Tile Insert (a) top (b) bottom.....	21
Figure 3-9: Elevator Lock System	21
Figure 3-10: Elevator System Visualization. (a) SCARA in print mode (b) SCARA with elevator lock turned into place (c) Bottom z-axis plate raised by continuing to turn lead screw (d) Printing platform in movement mode.....	22
Figure 3-11: Anchoring System Design	23
Figure 3-12: N20 Motor Slot Section View.....	23
Figure 3-13: Free Standing SCARA Prototype	24
Figure 4-1: Freestanding Print Test (a) Full View (b) Close-Up.....	25
Figure 4-2: Finished Result of Freestanding Print Test.....	26

Figure 4-3: Mobile Platform Testing (a) in print mode (b) Switching to movement mode (c) moving to position one (d) at position one (e) moving to position two (f) at position two..... 26

Figure 4-4: Cooperative Printing Test (a) part to be printed (b) first robot starts first section of print (c) first section of print done (d) first robot moving to second printing position (e) second and third section of print started on both robots (f) print finished 27

List of Tables

Table 1: Existing SCARA Feature Review	12
--	----

Table of Contents

Acknowledgements	1
Abstract	2
List of Figures	3
List of Tables	4
1. Chapter 1: Introduction	8
1.1 Motivation.....	8
1.2 Vision.....	9
1.3 Scope.....	10
1.4 Outline.....	11
2. Chapter 2: Concept Design	12
2.1 Evaluation of Existing SCARAs.....	12
2.2 Conceptual Design Requirements.....	14
3. Chapter 3: Prototype Design and Construction	15
3.1 Design Process and Overview	15
3.1.1 SCARA	16
3.1.2 Mobile Platform.....	18
3.1.3 Floor Tiles.....	19

3.1.4 Elevator System	21
3.1.5 Anchoring System.....	22
3.2 Assembly of Prototype.....	24
4. Chapter 4: Evaluation	25
4.1 Print Testing.....	25
4.2 Mobile Platform Testing.....	26
4.3 Cooperative Print Testing	26
4.4 Design Requirement Fulfillment.....	28
5. Chapter 5: Conclusions and Future Plans	30
5.1 Future Plans	30
6. References	32

Chapter 1: Introduction

The 3D printing industry has been rapidly expanding for the past years with a growth rate of 21% between 2017 and 2018 [1]. Due to this rapid growth, additive manufacturing (AM) has become recognized as “having the potential to fundamentally change the nature of future manufacturing” [1]. Despite this, the industry has so far been unsuccessful in removing two disadvantages of additive manufacturing: limited build volume and lack of automation for multiple prints. This paper presents an improved autonomous mobile 3D printing platform capable of cooperative 3D printing.

1.1 Motivation

The motivation for this research is to enter the emerging industry of fully automated general manufacturing, or what is otherwise known as Factory 4.0 [2]. Factory 4.0 is defined as “a model for enabling ubiquitous, convenient, on-demand network access to a shared pool of configurable manufacturing resources [3]”. With manufacturing being on-demand it lowers the waste created from over production and opens the possibility of a mass customizable market. To advance towards this manufacturing future, a cooperative 3D printing platform using mobile robots is proposed.

This research is also motivated by Dr. Wenchao Zhou, Lucas Galvan Marques, and Robert Austin Williams and their previous research in cooperative 3D printing and additive manufacturing methods [4, 5].

1.2 Vision

The purpose of this research is to develop a mobile 3D printing platform to be used for cooperative 3D printing. The intermediate design shown in figure 1 was created as a proof of concept.

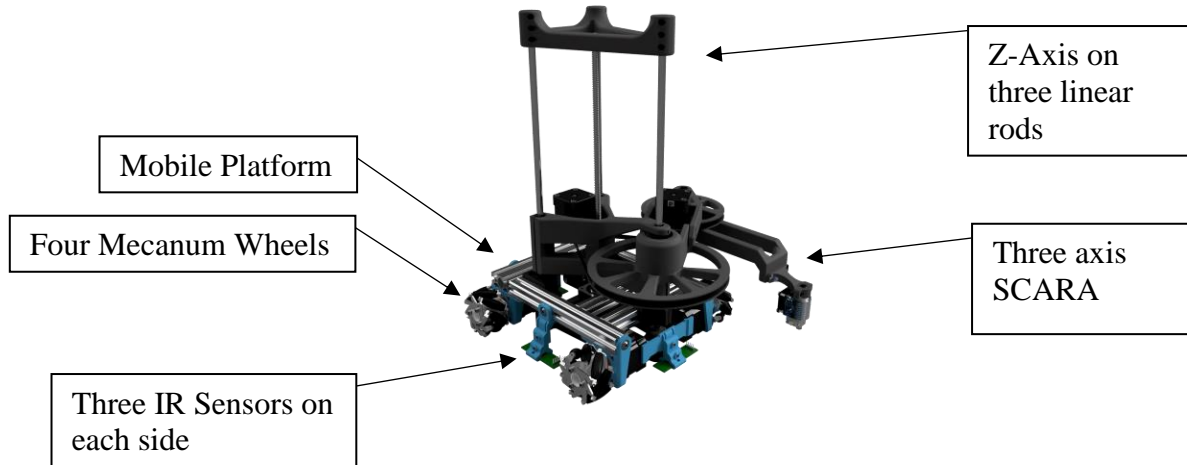

Figure 1-1: Intermediate Prototype Design

This concept features a two joint Selective Compliance Assembly Robot Arm (SCARA) for the printing functionality and a four-wheel mobile platform for the mobility functions of the robot. A SCARA type was chosen due to the fast and repeatable movements produced by this type of arm. Two joints are used to allow for full movement in the X-Y plane. The SCARA carries a basic connector that allows for the attachment of various tool ends for the robot. This would allow each robot to serve one of many different uses, including Fused Deposition Modeling (FDM) 3D printing, part assembly, and print bed deployment and retrieval. The mobile platform features sensors to align the robot on the tiled floor, mecanum wheels to provide omni-directional movement, and an anchoring system to fixate the robot during printing and to provide power for the robot from the floor. These features represent the long-term vision of the project, and as such

some are not at the stage of development to be discussed here. The following section outlines the scope of the project covered in this paper.

1.3 Scope

To advance towards this vision, this research concerns the designing, prototyping, and testing of a mobile 3D printing platform using a SCARA for print head control. Once design requirements were identified, the prototyping process began and after several iterations the version shown below was assembled.

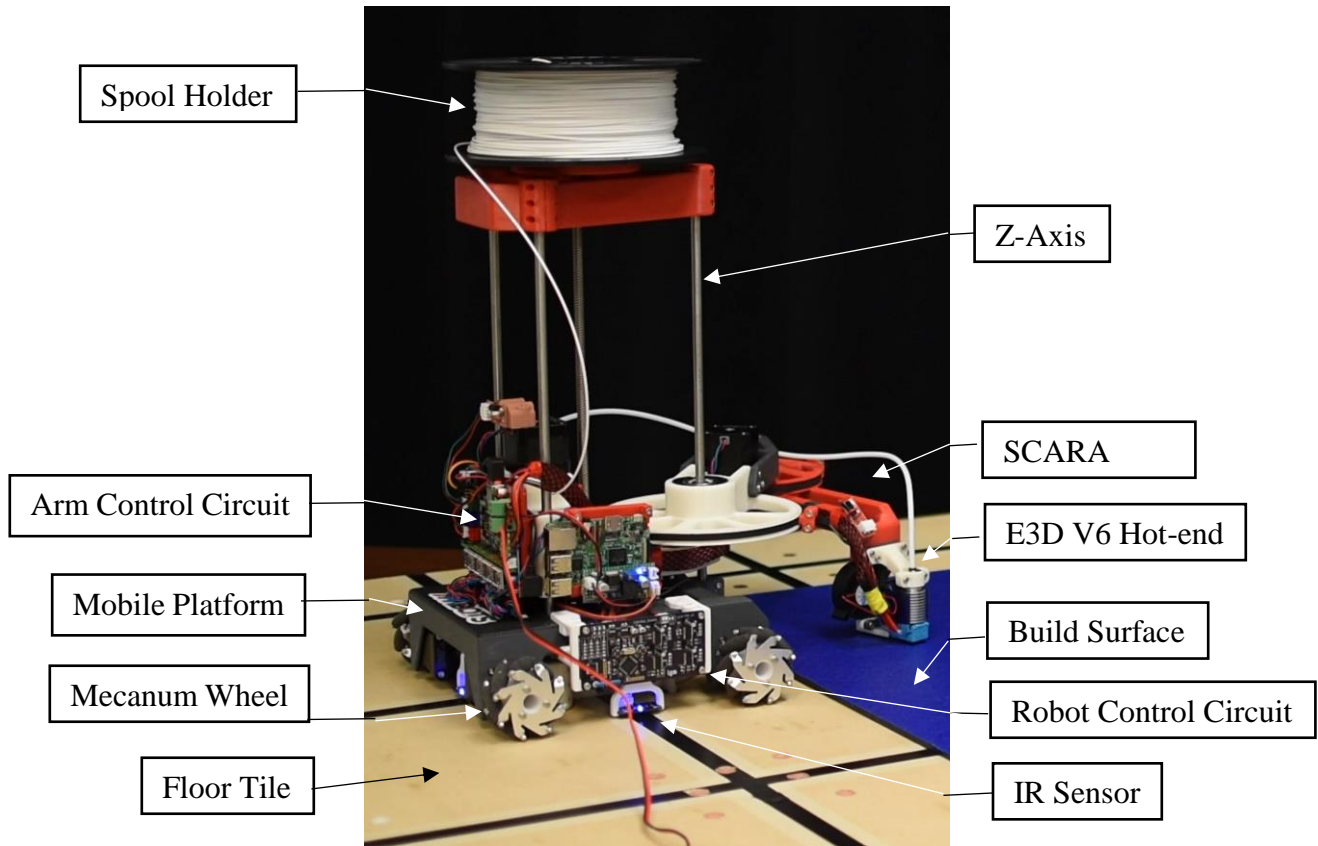

Figure 1-2: Picture of v5 prototype with text bubbles to identify systems

This thesis details the mechanical design and general functionality of this system as well as the evaluation of the prototype's performance. My personal contribution to the project has been the design of the arm, printed chassis, and the anchoring and elevator systems.

1.4 Outline

The content of the following chapters of this thesis are as follows. Chapter two goes over the process of identifying the design requirements for the robot and the desired features to be included in the prototype. Chapter three details the design of the individual systems of the prototype as well as the construction process and parts required. Chapter four relays the results gathered from prototype testing and the evaluation of the system. Chapter five concludes the thesis and presents the future plans for the project.

Chapter 2: Concept Design

Before the initial concept could be made, the requirements for the design needed to be identified and a conceptual design needed to be formed. This chapter gives an overlook of current industrial SCARAs, and outlines the conceptual design that was formed for this research.

2.1 Evaluation of Existing SCARAs

To develop an initial conceptual design, it was first necessary to review the design and features of currently available SCARAs. This was important because it allows us to examine existing designs and learn how they could be designed for the mobile platform. Table 2-1 below shows the main features of the SCARAs reviewed [6-11]. Table B-1 in the appendix shows more detailed specifications.

Table 1: Existing SCARA Feature Review

SCARA	Features
ABB IRB 910SC [6]	Modular design for different arm lengths, ambidextrous, z-axis at tool end
Dobot M1 [7]	Mobile platform available, ambidextrous, central z-axis
Epson G3 [8]	Left and right hand models available, z-axis at tool end
Fanuc SR [9]	Multiple mounting configurations (ceiling, wall, floor), ambidextrous, z-axis at tool end
Toshiba Machine THE400 [10]	Lightweight (15kg), ambidextrous, z-axis at tool end
Yamaha YK-XG [11]	Custom hollow z-axis motor for compact design, built in zone control to set working range, ambidextrous, z-axis at tool end

Figure 2-1 shows the common arm structure used in the arms reviewed, with the exception of the Dobot M1. As shown the z-axis lead screw is located at the end of the arm, this allows for the arm itself to be fixated more securely and for the z-axis assembly to be lighter since it has less weight on it; however, it means that the arm needs to be fixed at the maximum z-height of the arm. For a mobile platform, this would lead to a top heavy design that is not desirable.

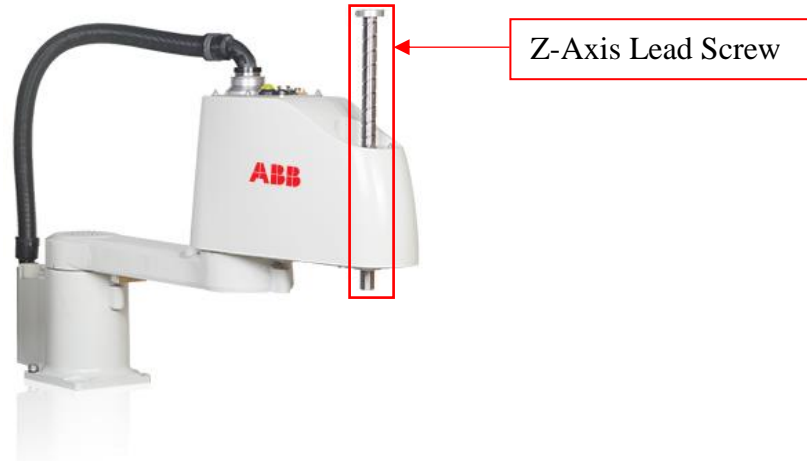

Figure 2-1: Tool-End Z-Axis [6]

Another important specification for this research is how closely the tool end of the arm can get to the base. For the arms reviewed it appears the closest they can fold to the base is between 100 and 170mm, while this is good, it is not adequate for the concept outlined in the following section. Figure 2-2 below shows the movement range for the Toshiba THE400 and represents a common movement range found in commercial arms with 144° of rotation range in the second arm joint [10].

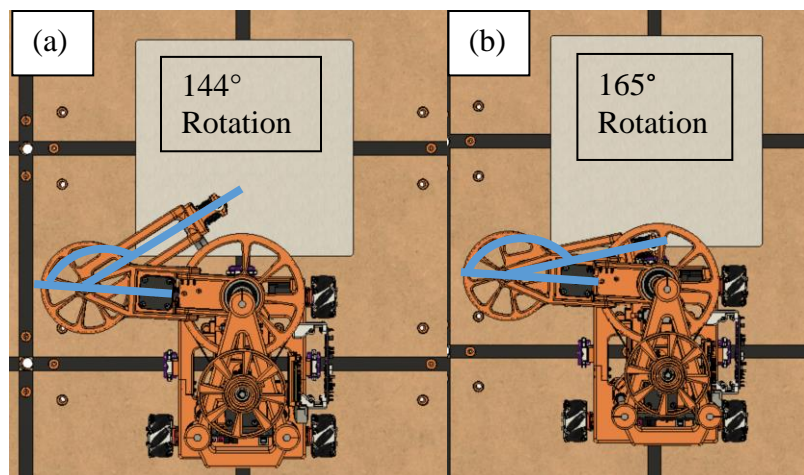

Figure 2-2: (a) Average Commercial SCARA Motion Range (b) Required Motion Range

2.2 Conceptual Design Requirements

Before the design process could begin, the design requirements for the prototype had to be set. These requirements were determined to be:

1. Robot be able to fit inside one print area of 300x300mm. This requirement was decided based on the area being large enough to fit for the mobile platform to fit in, and the full print area could be reached by a 400mm SCARA.
2. SCARA able to print within 50mm of the robot. Since a 400mm SCARA was decided, the first joint of the arm would need to be positioned just 50mm from the print area, and the tool-end would need to be able to reach within 50mm of the first joint.
3. Robot able to carry the necessary payload weight. For this prototype, the only required payload was the hot-end and the weight of the arm itself.
4. Acceptable print quality. One of the most important goals of this prototype, it was required for the arm to be able to print at an acceptable quality. This was defined as being a quality comparable to that produced by a consumer grade printer.
5. Capable of cooperative printing. This requires that when arms are positioned to operate within one print area, that the arms minimize the number of possible collision points.
6. Minimize time taken changing between the robot's printing and movement mode. For the robot to be able to move and print from a stable position, a mechanism was required to attach the robot to the floor during printing, and release from the floor to allow for movement. This requirement states that this mechanism take at most 10 seconds.

Chapter 3: Prototype Design and Construction

This chapter outlines the design and construction of the prototype that resulted from the concept in the previous chapter. The design shown is the most current version of the robot and is the result of multiple iterations and many hours of intermediate testing. The first section describes the process taken to reach this version and the design of each of the systems and their functionality. The second section gives a brief overview of the assembly process for the robot.

3.1 Design Process and Overview

After the concept was generated, my work on the design process began with the design of the arm. This part of the platform went through the most revisions, with the fifth version being shown here. The first two versions were designed as proof of concepts and as such were not prototyped. From version one and two I learned the arm geometry required to achieve the range of motion required. Version three was designed and prototyped to test the movements and rigidity of the design. Version four focused on increasing the rigidity of the arm while reducing the weight. Finally, the current version centered on designing the arm to work with the mobile platform. Images of these designs can be seen in figure 3-1.

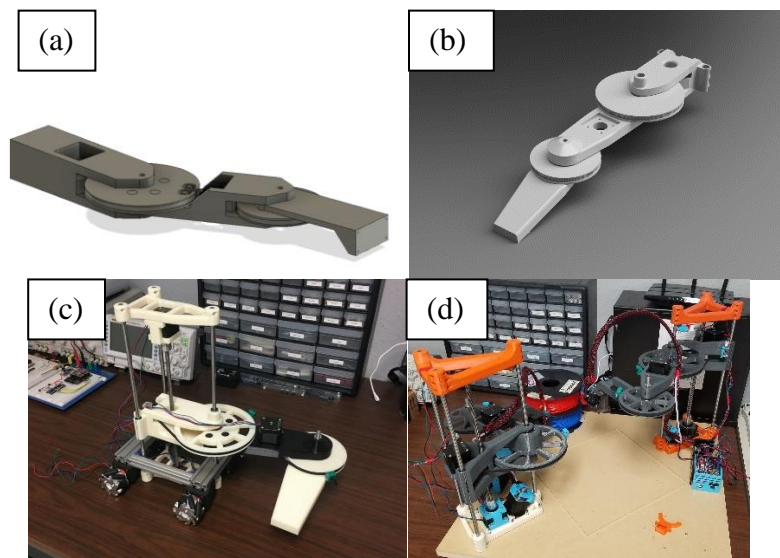

Figure 3-1: Previous Designs (a) Version 1 (b) Version 2 (c) Version 3 (d) Version 4

The design of this mobile printing platform consists of five systems: the SCARA, the mobile platform, the floor tiles, the elevator, and the anchoring system. The SCARA provides movement for the tool head in the x, y and z direction. The mobile platform acts as a carrier for the SCARA and provides position information for the location of the robot. The floor tiles are the surface that the robot moves on and anchors to. The elevator system allows the robot to switch between movement and printing modes and the anchoring system fixates the SCARA during printing to provide stability. Figure 3-1 below shows the mobile printing platform design as well as a breakdown of each of the systems.

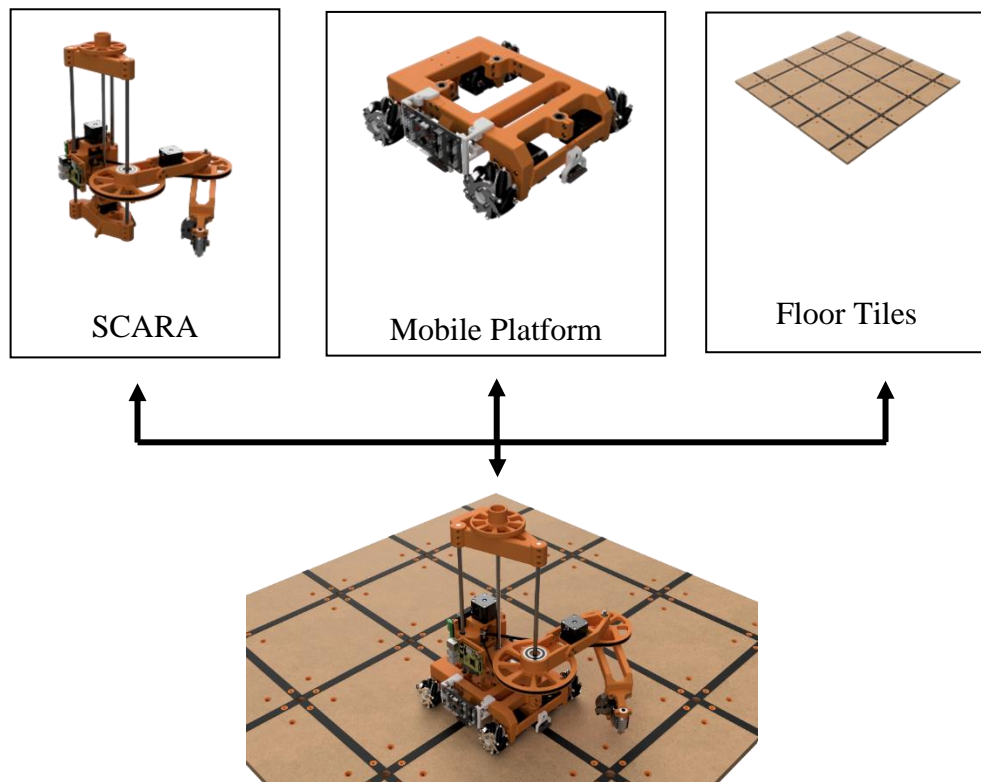

Figure 3-2: Mobile Printing Platform and System Breakdown

3.1.1 SCARA

The SCARA shown in figure 3-2 was the first part designed for the printing platform. The structure is fully 3D printed from ABS plastic and was produced at the University of Arkansas

Mechanical Engineering Department. The arm is driven by three NEMA 17 motors, two belt driven for the joints of the arm, and one driving a lead screw for the z-axis. The extruder was mounted onto the z-axis section of the arm and utilized a Bowden system to feed filament to send filament to the hot-end located on the tool end of the arm. The hot-end assembly consisted of a E3D V6 hot-end, a 50mm radial fan for part cooling, and a fan shroud to direct the airflow to the extruded plastic. The SCARA also carries the spool holder for filament and the control circuits for the arm, which include an Arduino Type B and a MKS GenL V1.0 3D printer microcontroller board. The SCARA uses three end-stops to calibrate each of the axes of the arm. Finally, the SCARA carries part of the elevator system that will be described in section 3.1.4. Figure 3-2 shows the design features.

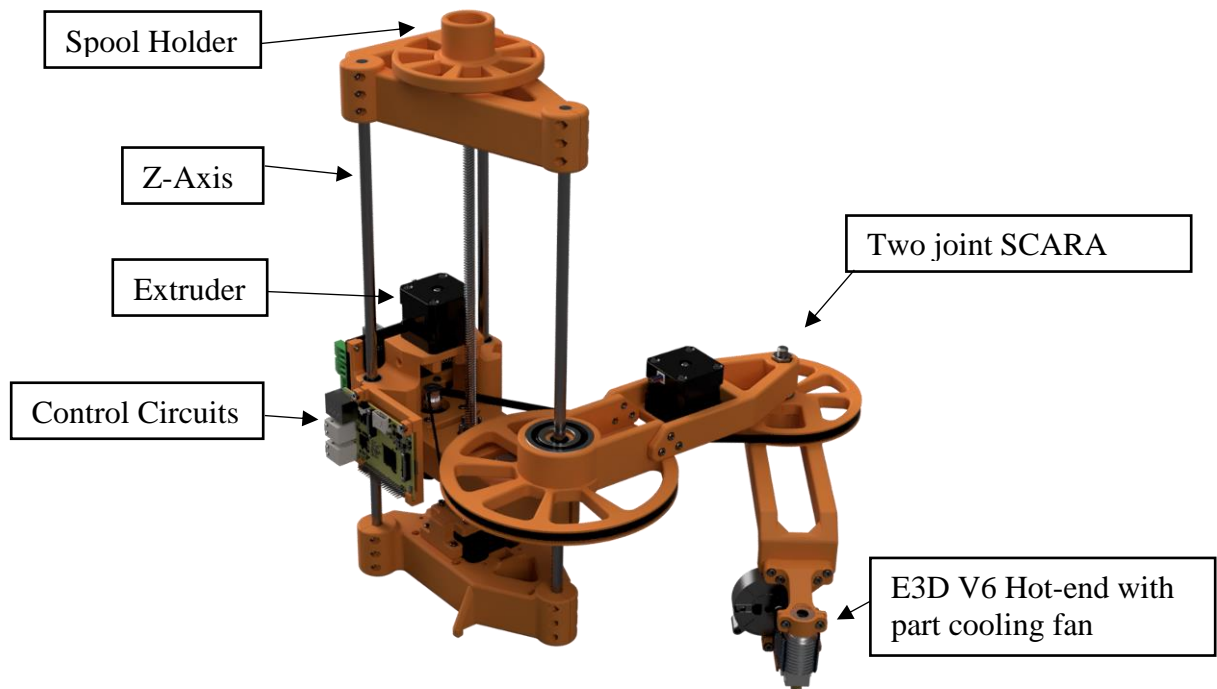

Figure 3-3: SCARA Breakdown

3.1.2 Mobile Platform

Figure 3-3a shows the initial design of the chassis for the mobile platform. This design was found to consist of too many parts that made assembly cumbersome and made repairs difficult. Due to this the frame was redesigned to be 3D printed and resulted in the design shown in figure 3-3b. This design reduced the number of components (excluding screws) from 19 to 2. This reduced the amount of time for construction and increased the reparability of the frame.

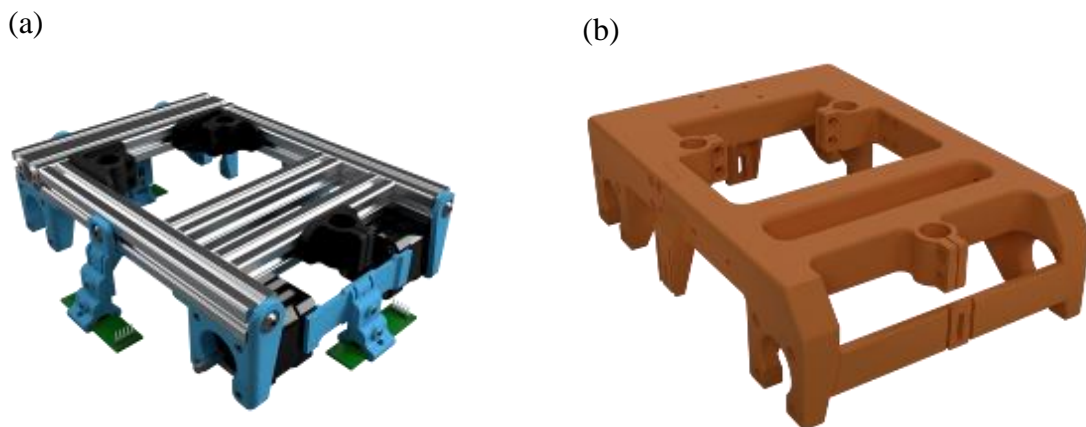

Figure 3-4: Chassis Design (a) initial (b) final

The robot moves on four omnidirectional mecanum wheels each powered by a NEMA 17 motor. The chassis also carry four infrared sensors that guide the robot in its movements and allow for the robot to know its location on the floor tiles discussed in the next section. The SCARA connects to the chassis via three linear bearings to allow the z-axis assembly to move vertically, the function of this will be explained in the Elevator System section. Finally the chassis carry the circuit for controlling the mobile platform's movement. Both the infrared sensor circuit and the mobile platform control circuit were custom designed by Lucas Galvan Marques. The mobile platform parts shown in figure 3-4 features:

1. Two piece 3D printed frame.
2. Mecanum wheels driven individually by NEMA 17 motors to allow for omnidirectional movement.
3. IR Sensors to detect the navigation lines on the floor tiles.
4. Control circuit operates the wheels and sensors.
5. Linear bearings to connect mobile platform to SCARA.

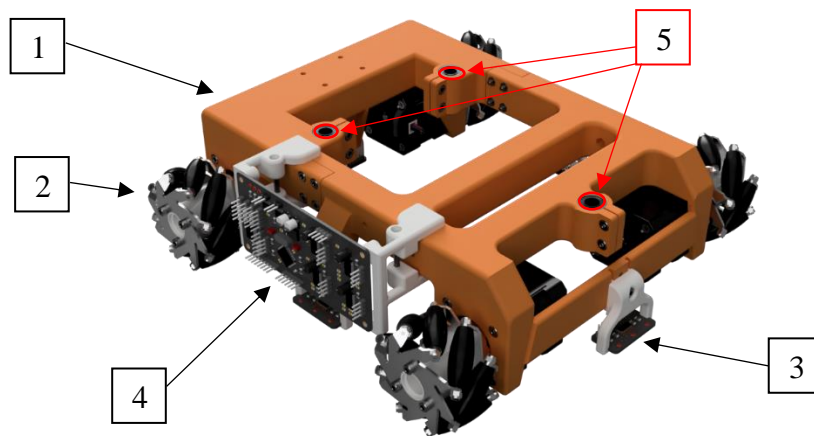

Figure 3-5: Robot Mobile Platform Breakdown

3.1.3 Floor Tiles

A custom floor tile system was necessary for this project due to the need for guidance lines for the robot and anchoring points for the robot and print surface. This resulted in a design for a CNC cut Medium-density fibreboard (MDF) and 3D printed floor tile. The design shown in figure 3-5 shows the floor tile design which features:

1. Black tape that serves as the contrast needed for the robots' infrared sensors to line-follow and keep track of position.
2. Four alignment holes used during the anchoring process to correct any positioning errors. These holes are cone shaped so that as the elevator described in the next section lowers,

the robot can shift into the correct position so long as the infrared sensors position the robot within 5mm of the correct position, which in testing it has 100% of the time. Four cones were needed so the robot could mount to the floor in any orientation.

3. Four anchor points, two of these are used during the anchoring process to attach the robot to the floor. Four are needed so that the robot can anchor in any direction. Each of these holes has an M3 nut inside for the robot to anchor to.

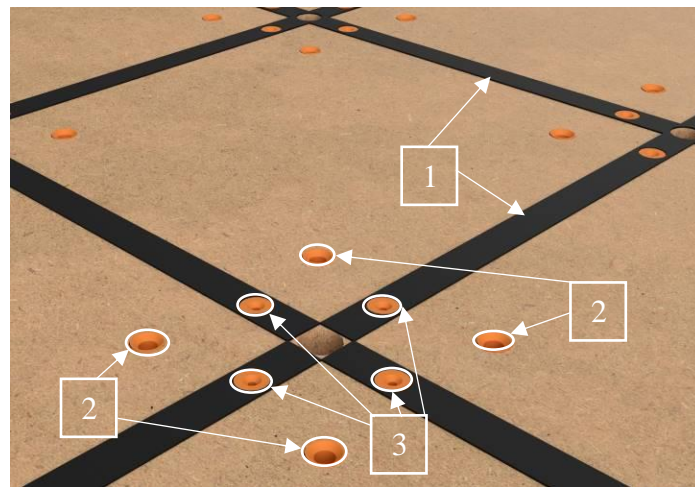

Figure 3-6: Floor Tile Design Breakdown

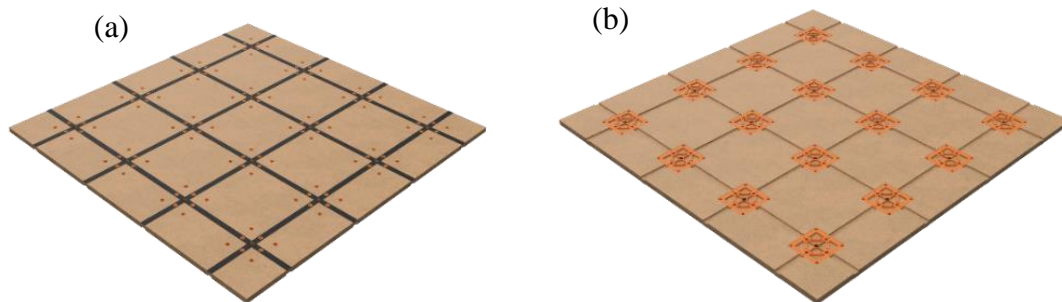

Figure 3-7: Floor Tile Design (a) top (b) Bottom

Figure 3-8 shows the 3D printed insert in the bottom of the floor tile that are used to create the cone shapes on the alignment holes and the hex locations for the anchor points. The design features screw holes so the part can be attached to the board with wood screws.

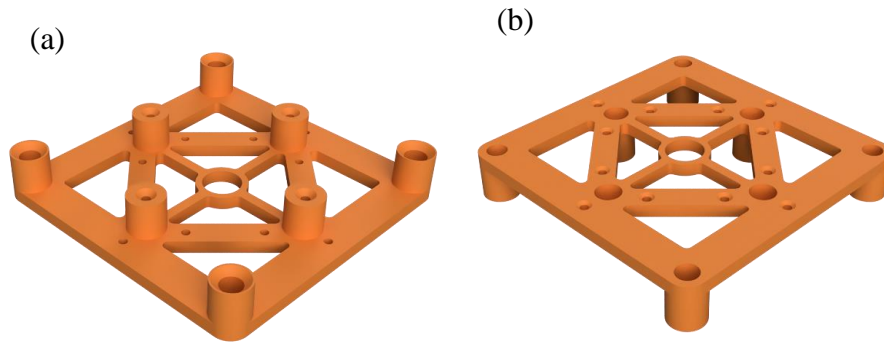

Figure 3-8: Floor Tile Insert (a) top (b) bottom

3.1.4 Elevator System

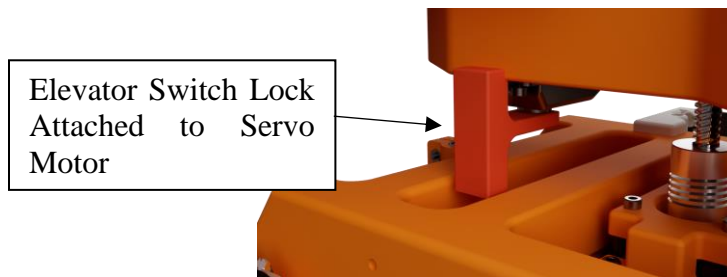

Figure 3-9: Elevator Lock System

An elevator system was required to allow the mobile platform to switch between printing and movement modes while providing optimal alignment for the SCARA. This system functions by connecting the SCARA to the mobile platform with linear bearings, allowing the z-axis of the arm to move up and down. Next, the SCARA is locked using a servo motor and a 3D printed part that when turned into place collides with the mobile platform chassis, preventing the arm from lowering further. This system is shown in Figure 3-8. Once the arm cannot lower any further, if the z-axis stepper continues to turn the lead screw, the bottom plate of the z-axis is raised up to the bottom of the chassis frame. This concept is shown in figure 3-9. Reversing these actions returns the robot to printing mode. Being able to raise and lower the z-axis opens the possibility of locating the alignment cones and anchoring system on the robot inside the bottom z-axis plate of the

SCARA, and using this system to raise them above the floor so that the mobile platform is free to move. This allows for the use of one motor for two uses, lowering cost and compacting the overall design.

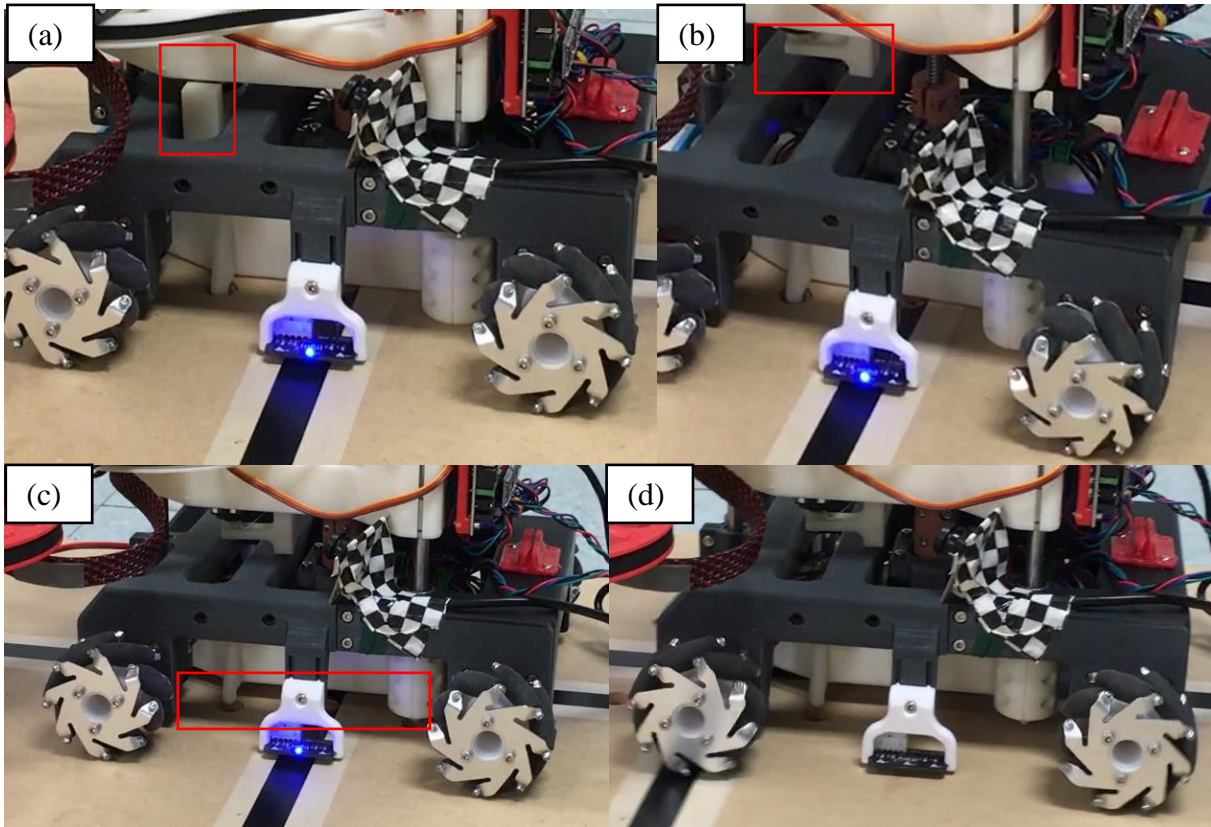

Figure 3-10: Elevator System Visualization. (a) SCARA in print mode (b) SCARA with elevator lock turned into place (c) Bottom z-axis plate raised by continuing to turn lead screw (d) Printing platform in movement mode

3.1.5 Anchoring System

The final system, the Anchoring system, is used to fixate the SCARA to the floor tiles during printing to increase stability and ensure constant alignment during prints. The anchoring system operates using two N20 motors inside of the bottom z-axis plate of the SCARA. Each motor turns a 20mm M3 lead screw, allowing them to screw into the M3 nuts inside the floor tiles previously mentioned in section 3.1.3. The N20 motors are free to move vertically inside their mount, allowing them to be pushed upwards by the floor as the elevator is lowered as to not

interfere with the alignment cones adjusting the position of the robot. Figure 3-9 below shows the anchoring system design. Figure 3-10 shows a close-up section view of the N20 motors. The numbered components in figure 3-9 are:

1. SCARA z-axis.
2. Four cones to align robot with floor tile.
3. Two N20 lead screw motors to attach robot to floor tile.

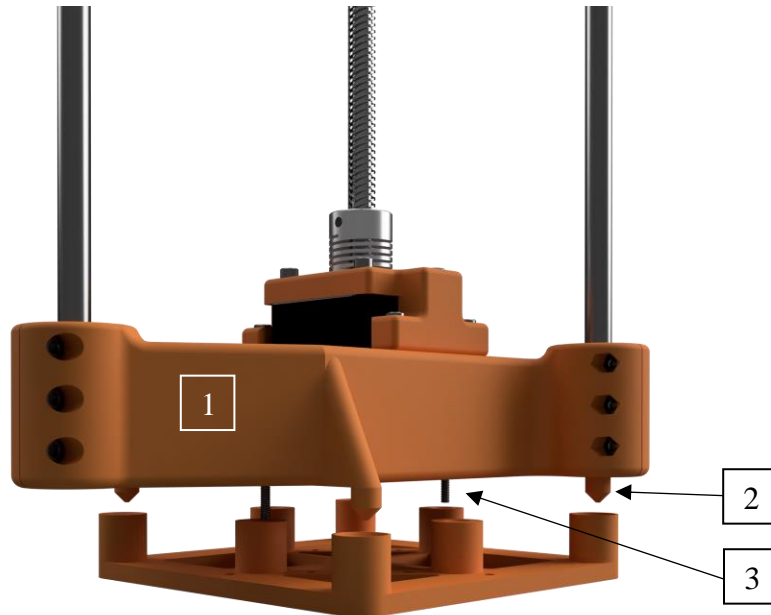

Figure 3-11: Anchoring System Design

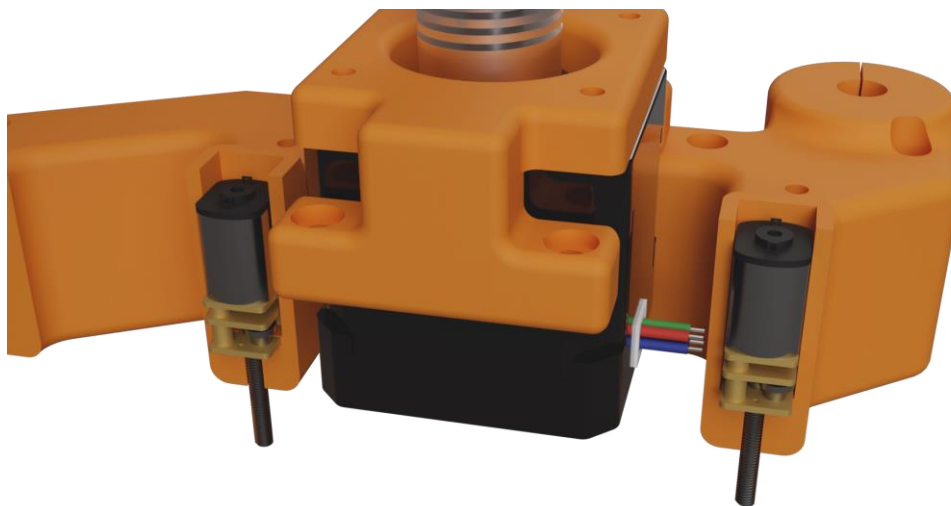

Figure 3-12: N20 Motor Slot Section View

3.2 Assembly of Prototype

As the computer models were finished, a physical model was produced and assembled for testing. For early print testing only the SCARA was assembled and attached to an MDF board for testing. This testing board is shown in figure 3-10. Once the mobile platform design progressed the two were assembled together for testing of the full system. The assembled robot and board are shown in figure 1-2.

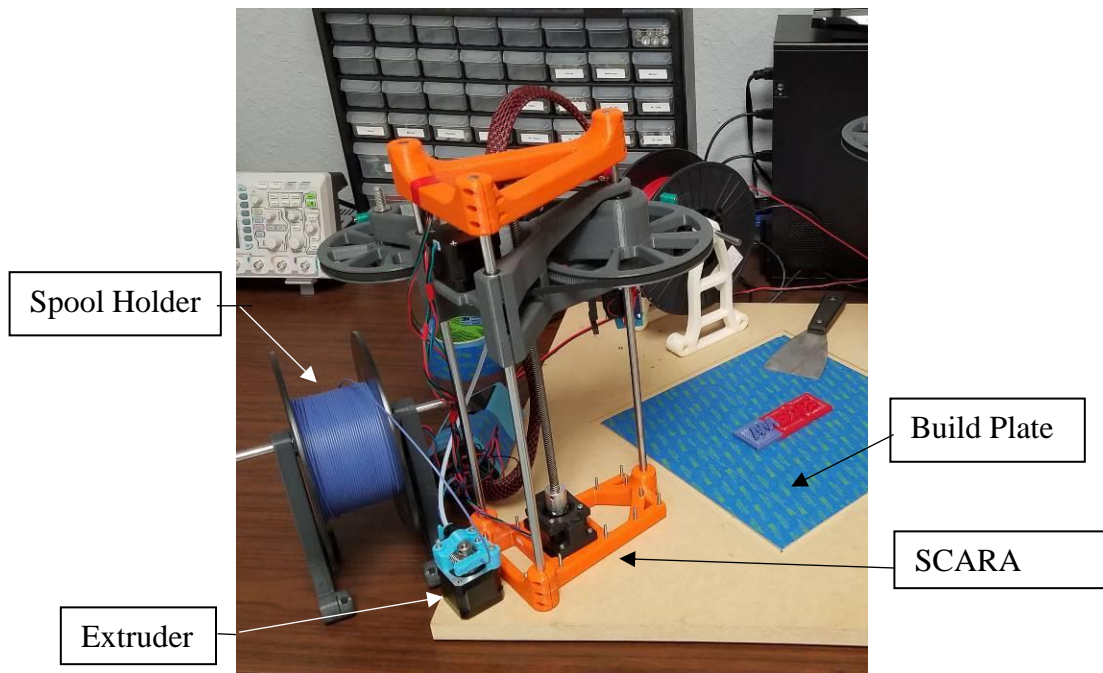

Figure 3-13: Free Standing SCARA Prototype

Chapter 4: Evaluation

As iterations of the design were assembled, testing was done to evaluate the performance of each iteration. This chapter details three key testing phases during the development process. The first section reviews the results from testing a free-standing SCARA design for print quality and performance. The second section evaluates the performance of the mobile platform itself. The third and last section reports on the test results of the platforms ability to print cooperatively.

4.1 Print Testing

The first round of tests were to ensure that the SCARA could print with an acceptable quality regardless of whether it was on a mobile platform or not. For this test one of the free standing SCARAs was used to print a Benchy (a boat test model that is generally used to quality test 3D printers)[12] that was scaled up to 300% for a height of 172mm. The model was sliced using a standard slicer and the G-code was converted from Cartesian coordinates to SCARA coordinates.

Figure 4-1a shows the arm printing the model with a couple previous tests in the foreground. Figure 4-1b shows a close up of the model during the printing process. Figure 4-2 shows the finished model. As can be seen in the figures the print quality was successful. After this test we moved to testing the mobile platform and cooperative printing capabilities.

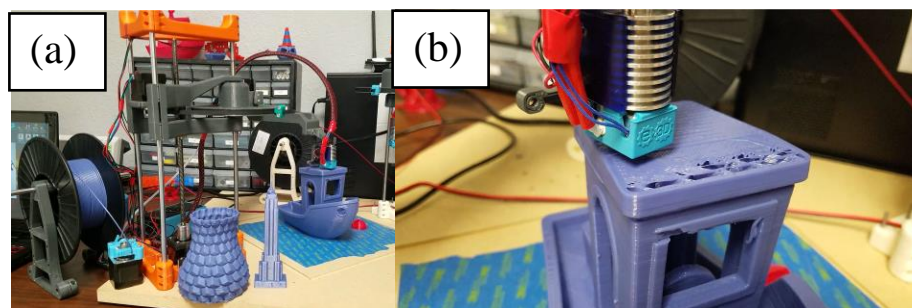

Figure 4-1: Freestanding Print Test (a) Full View (b) Close-Up



Figure 4-2: Finished Result of Freestanding Print Test

4.2 Mobile Platform Testing

The next round of testing was done on the mobile platform and its ability to move between printing positions, attach and release the anchoring system, and do so repeatedly. For this test, the mobile platform was moved to different positions on the floor tile and anchored to them. After some adjustments to the floor tile and the line following code the mobile platform was able to accomplish this 100% of the time. Figure 4-3 below shows photos during the test at different phases.

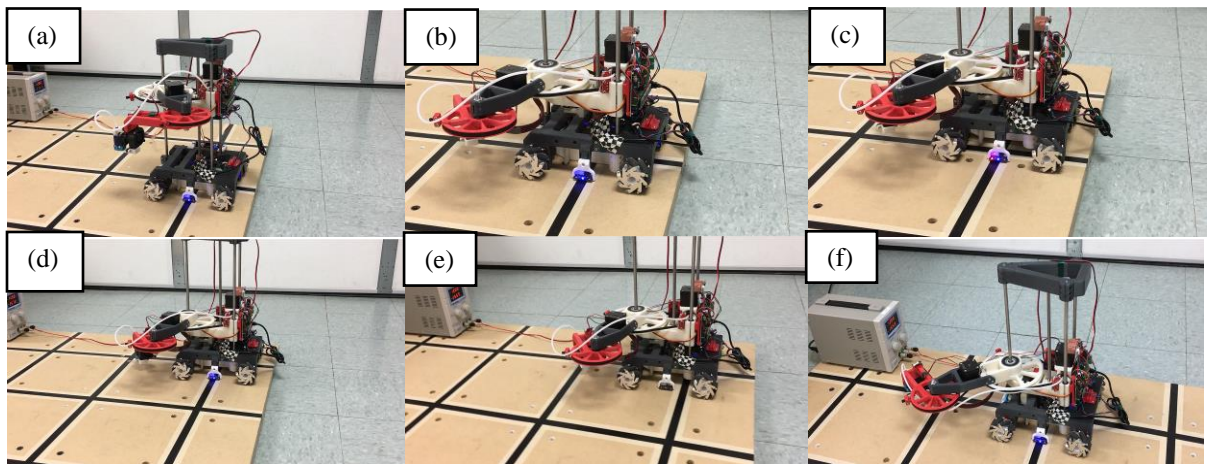

Figure 4-3: Mobile Platform Testing (a) in print mode (b) Switching to movement mode (c) moving to position one (d) at position one (e) moving to position two (f) at position two

4.3 Cooperative Print Testing

The main test for the robot was to see how well it could print cooperatively. This being the main test, a printing demo was made to showcase the capabilities of the platform. For this demo, an 840mm long honeycomb structured beam was made. Since it is nearly three print beds long, it

would require three print jobs to be completed. Two robots were used for this demo, one of them stayed in one place to print one piece of the model, and another printed the other two, changing printing location between each part. Figure 4-4 shows the printing demo at different phases. As can be seen, the demo was a success. The robots printed the beam in five hours while it was estimated by a common slicer software to take 10 hours on a desktop printer using the same layer height of 0.5mm and nozzle diameter of 0.4mm. Overall the test was successful with the biggest issue being slight misalignment between two of the sections.

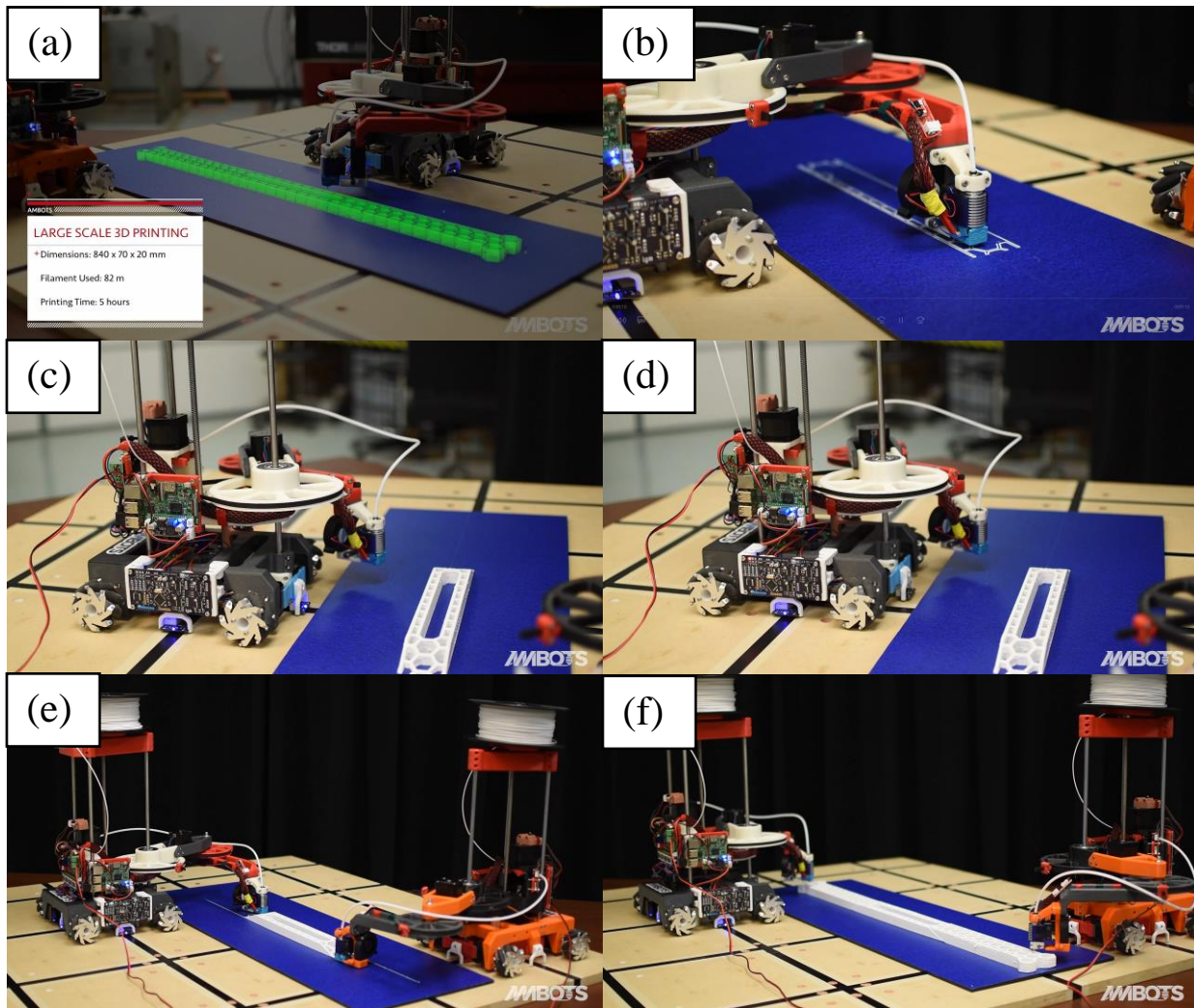

Figure 4-4: Cooperative Printing Test (a) part to be printed (b) first robot starts first section of print (c) first section of print done (d) first robot moving to second printing position (e) second and third section of print started on both robots (f) print finished

4.4 Design Requirement Fulfillment

In Chapter 2 of this paper, a set of design requirements were laid out. This section review the success of this prototype in accomplishing these requirements. The outcome of the design requirements discussed in chapter two are:

1. Robot be able to fit inside one print area of 300x300mm.

The robot has a footprint of 250x250mm, so well within the requirement. However, the arm itself extends significantly into the adjacent print bed, enough that two robot are unable to print side by side. This was not seen as a problem as the research described is still in the prototyping phase, this issue will be fixed in a later version.

2. SCARA able to print within 50mm of the robot.

A freestanding arm is able to print within the 50mm requirement. The robot mounted arm is able to print within 100mm of the robot, causing a semicircle of print bed area to be unreachable. This large difference is due to a change in placement of one of the calibration end stops on the arm when it was redesigned to be used on the robot. This problem has a solution but was not yet solved at the time of writing.

3. Robot able to carry the necessary payload weight.

This requirement was completed successfully, albeit with the printing hot-end being the only payload currently on the arm, during load testing the arm was able to lift and carry 1kg.

4. Acceptable print quality.

As can be seen from the print tests earlier in the chapter, the robot produced a decent print quality. Print failures were greatly reduced during the design process and overall quality has increased. Although its quality won't be winning any awards yet, some of the issues present can be resolved through further calibration of the print settings, and the others will be solved in future updates of the arm design.

5. Capable of cooperative printing.

Through several iterations of the tool end the number of collision points has been reduced enough to where to reduce them further would require a smaller hot end. The current design is capable of supporting four arms printing on a single print bed. Future software updates and testing will be required before this feature is available.

6. Fast changing time between robot printing and movement mode.

The robot takes approximately 10 seconds to switch between its moving and print modes. This includes the z-axis being lowered to the floor, the anchoring system attaching to the floor, and the z-axis lock being turned out of the way. These results were seen as a success.

Chapter 5:

Chapter 5: Conclusions and Future Plans

In this thesis, a SCARA based 3D printing platform was presented for an improved cooperative manufacturing system. This system is a step towards a manufacturing future where swarms of mobile robots with different tool heads work together to manufacture products on demand. First, the SCARA was designed and validated along with the script to convert G-code to SCARA coordinates. Next the mobile platform was developed to add mobility to the SCARA. Finally, the anchoring and elevator system were designed to allow the robot to switch between printing and movement modes. Multiple tests were done during the process to troubleshoot and confirm the functionality of each system before the full cooperative printing test was done.

5.1 Future Plans

Some of the planned features were not yet implemented at the time of writing. These future plans include:

1. Redesigning the SCARA to be machined form aluminum. This update is currently in the process of being completed and consists of redesigning the SCARA to be made from machined aluminum. Although the printed design has worked well for the fast redesigns that were required in the early development process and has yielded decent results, a machined aluminum version of the arm will add rigidity to the arm as well as making it easier to manufacture for a production model.
2. Creating an electrical connection between the robots' anchoring system and the floor tile. This would allow for powering the robot during printing.
3. Implementing an automatic bed leveling system. The current calibration process calibrates the arm with respect to the robot and not the printing surface. A planned update is to add a

bed leveling sensor to the tool end of the arm to allow the arm to calibrate its positioning relative to the printing surface. This would greatly increase the reliability of the printing process.

4. Creating a new tool head for the robot to facilitate automatic print bed deployment. This plan includes the design of a new tool end that would allow for the robot to pick up and carry a clean print bed onto the floor tiles and set up a new printing location for another robot to print on. This would increase the overall automation of the system and would be another step in advancing the robot into an automated manufacturing solution.

References

- [1] McCue, TJ. “*Wohlers Report 2018: 3D Printer Industry Tops \$7 Billion.*” Forbes. Jun 4, 2018. <https://www.forbes.com/sites/tjmccue/2018/06/04/wohlers-report-2018-3d-printer-industry-rises-21-percent-to-over-7-billion/#436acb12d1a4>
- [2] Dilberoglu, Ugur & Gharehpapagh, Bahar & Yaman, Ulas & Dolen, Melik. “*The Role of Additive Manufacturing in the Era of Industry 4.0.*” Procedia Manufacturing. 2017. 11. 545-554. 10.1016/j.promfg.2017.07.148.
- [3] Liu Y, Xu X. “*Industry 4.0 and Cloud Manufacturing: A Comparative Analysis.*” ASME. *J. Manuf. Sci. Eng.* 2016;139 (3):034701-034701-8. doi:10.1115/1.4034667.
- [4] Lucas Galvan Marques, Robert Austin Williams, Wenchao Zhou. “*A Mobile 3D Printer for Cooperative 3D Printing.*” Solid Freeform Fabrication. 2017.
- [5] Jace McPherson, Wenchao Zhou, (2018) “*A chunk-based slicer for cooperative 3D printing*”, Rapid Prototyping Journal, <https://doi.org/10.1108/RPJ-07-2017-0150>
- [6] “*IRB 910SC SCARA.*” ABB. 2019. <https://new.abb.com/products/robotics/industrial-robots/irb-910sc>
- [7] “*DOBOT MI.*” DOBOT. 2019. <https://www.dobot.cc/dobot-m1/product-overview.html>
- [8] Epson. “*Epson G3 SCARA Robots.*” Epson America. 2019. <https://epson.com/For-Work/Robots/SCARA/Epson-G3-SCARA-Robots---350mm/p/RG3-351SST13>
- [9] “*SCARA Robot SR-3iA.*” Fanuc. 2019. <https://www.fanuc.eu/de/en/robots/robot-filter-page/scara-series/scara-sr-3ia>
- [10] “*SCARA Robot THE400.*” Toshiba Machine. 2017. <https://www.toshiba-machine.co.jp/en/product/robot/lineup/th/THE400.html>
- [11] Yamaha Motors “*Small Type SCARA Robots YK-XG.*” Yamaha. 2019. <https://global.yamaha-motor.com/business/robot/lineup/ykxg/small/index.html>
- [12] CreativeTools “*#3D Benchy.*” Makerbot,inc. Apr 9, 2015. <https://www.thingiverse.com/thing:763622>