

12-2019

# Load Flow Analysis of 138/69kV Substation Using Electrical Transient & Analysis Program (ETAP)

Vanessa Abadia Gomez

Follow this and additional works at: <https://scholarworks.uark.edu/eleguht>

 Part of the [Electrical and Electronics Commons](#), [Power and Energy Commons](#), and the [Service Learning Commons](#)

---

## Recommended Citation

Abadia Gomez, Vanessa, "Load Flow Analysis of 138/69kV Substation Using Electrical Transient & Analysis Program (ETAP)" (2019). *Electrical Engineering Undergraduate Honors Theses*. 67.  
<https://scholarworks.uark.edu/eleguht/67>

This Thesis is brought to you for free and open access by the Electrical Engineering at ScholarWorks@UARK. It has been accepted for inclusion in Electrical Engineering Undergraduate Honors Theses by an authorized administrator of ScholarWorks@UARK. For more information, please contact [ccmiddle@uark.edu](mailto:ccmiddle@uark.edu).



College of Engineering  
Department of Electrical Engineering

An undergraduate honors thesis  
submitted in partial fulfillment of the requirements for the  
Honors Studies in Electrical Engineering

***“Load Flow Analysis of 138/69kV Substation  
Using Electrical Transient & Analysis Program (ETAP)”***

**Submitted by:**

Vanessa Abadia Gomez

Bachelor of Science in Electrical Engineering

Date Submitted:	4/27/2019
Thesis Advisor:	Mr. Robert Saunders
Sponsor Company:	Black & Veatch

***“Load Flow Analysis of 138/69kV Substation  
Using Electrical Transient & Analysis Program (ETAP)”***

Honors Senior Thesis

by

Vanessa Abadia Gomez

**❖ ABSTRACT**

This paper examines the load flow analysis of a high-voltage substation using ETAP, and explores options for improving the voltage profile of the system. This study yields critical information about the system, such as the voltage drop at each feeder, the voltage at each bus, as well as real and reactive power losses at the different branches and feeders. In this power flow examination, the system’s performance is evaluated for different operating conditions, so that control measurements can be applied if necessary. The experimental results are used for proposing a plan of using fixed and switched shunt capacitor banks to improve the voltage stability of the substation. Distribution systems include inductive loads along with transformers and transmission lines, which account for quite significant power loss due to lagging current. The introduction of strategically sized and positioned shunt capacitors within the distribution system, helps to counteract losses due to inductive elements and improves the voltage profile of the network. The problem of capacitor allocation includes the location, type (fixed or switched), and size of capacitor. To determine the sizing of the shunt capacitor bank necessary to compensate inductive effect of the loads, power flow equations are used along with the ETAP simulation results. The results obtained in the load flow analysis will be substituted into these equations to perform a power factor correction. Overall, the purpose of this paper is to use the ETAP software to analyze the load flow operation of the substation, and perform the necessary adjustments so that it meets the National Standards for Electrical Power Systems.

## Table of Contents

Abstract.....	2
Introduction .....	5
Theoretical Background .....	6
Experimental Procedure.....	8
Results.....	9
Conclusion .....	20
References .....	21

## List of Figures

Fig. 1. Complete One-line Diagram.....	9
Fig. 2. Voltage Drop for 0.60 PF Inductive Load. ....	10
Fig. 3. Load Flow Simulation for Unchanged Conditions.....	11
Fig. 4. Load Flow Simulation for Unchanged Conditions.....	12
Fig. 5. Result Window Transformer Overloaded Warning.....	12
Fig. 6. Power Factor Correction by Increasing Size of Fixed Capacitor Bank. ....	14
Fig. 7. Result Window for Feeders with Resized Fixed Capacitor Bank.....	14
Fig. 8. Load Flow Results with Resized Fixed Shunt Capacitor Bank.....	15
Fig. 9. Result Window for Power Transformer without Overloading Warning.....	16
Fig. 10. Load Flow When PF Is Close to 1 for Fixed Shunt Cap Bank. ....	17
Fig. 11. Installation of Switched Capacitor Bank (Open Switch).....	18
Fig. 12. Installation of Switched Capacitor Bank (Closed Switch). ....	18
Fig. 13. Internal Configuration of a Switched Shunt Capacitor Bank.....	19

## List of Tables

Table. 1. Power Factor Assignment to Feeders for First Scenario.....	10
Table. 2. Power Factor Assignment to Feeders for Second Scenario.....	16

## ❖ INTRODUCTION

In this paper, a load flow analysis is performed to a 138/69kV substation using ETAP. The substation layout and equipment choice were provided by Black & Veatch (B&V) as part of a Senior Design project. The scope of this report encompasses the load flow results, and explains how these were used to implement changes on the feeders that resulted in an improved voltage profile. In this context, the load flow study is performed for different operating conditions or scenarios to determine what control measurements are necessary to prevent system breakdown. The results of the load flow study for the different scenarios, will be substituted into power flow equations destined to improve the power factor of a given bus. The equations define the relationship of the real and reactive power with the desired power factor. They yield the updated size of fixed or switched shunt capacitor banks required to compensate the inductive effect of the loads. To verify that the theoretical results are accurate, the load flow is performed with the updated parameters for the capacitor banks.

As early introduced, the power flow study for this substation will be performed on ETAP. The acronym ETAP stands for Electrical Transient and Analysis Program. This software is a comprehensive platform for the design, simulation, and protection of electrical networks. ETAP not only provides solutions to substation designs, but also specializes in generation, transmission, and distribution of power systems. The software relies on predictive simulation. This allows the user to perform analysis using real-time system parameters and may also simulate “what if” scenarios to predict equipment malfunctioning. ETAP also uses preventive simulation, which allows the user to see any automated alarms and warnings. These alarms and warnings are based on events that could potentially occur (generator outages/contingencies) and corrective action will be suggested. ETAP analyses are always verified and validated against field results, real system measurements, and hand calculations.

The one-line diagram of the electrical system in question is composed by several pieces of equipment, each with a specific function. All of the components for this substation are high-voltage components. Some of the most important components are the power source, disconnect switches, circuit breakers, capacitor banks, transmission lines, as well as power transformers, potential transformers, and current transformers. The layout for the substation and the operation

parameters for each component on the one-line were specified in the documentation provided by Black & Veatch, with the exception of the transmission line parameters. The process of choosing the most suitable type of conductors for the transmission lines is discussed in the next section.

## ❖ THEORETICAL BACKGROUND

For a deeper understanding of this thesis, it is important to cover important information about the load flow analysis. The load flow analysis is performed to determine whether the system voltages operate within the specified voltage limits under normal or fault operating conditions. It is used to determine the voltage drop at different points of the system, the voltage reading at each bus, and real and reactive power losses through each branch and feeder. ETAP creates warnings if a feeder bus is below the nominal voltage. Likewise, the load flow study is often performed to identify the need for additional generation units, and the addition or replacement of capacitors and/or reactors to maintain system voltages within specified limits [1].

From the information gathered from the load flow test, the voltage profile of the system is of critical importance. If there is a substantial variation in the voltage over the system, large reactive flows will occur. This could lead to an increase in real power losses, and in extreme scenarios, a likelihood for system breakdown. It is a common practice to install capacitor banks when a particular bus exhibits particularly low-voltage, to provide reactive compensation to the load. The major cause of all the major power system disturbances is due to under voltage [2].

The load flow study can also be performed to determine the optimum size and location of capacitors. The simplest way to improve power factor is by adding power factor (PF) correction capacitors to the electrical system. PF correction capacitors act as reactive current generators. They help offset the non-working power used by inductive loads, thereby improving the power factor [3].

In the one-line drawing, the first two current transformers closer to the 138kV bus have a winding ratio of 3000:5. The rest of the transformers below it, have a winding ratio of 2000:5. This information is in agreement with the parameters displayed in the B&V original blueprints for the substation.

### ***Key Terms:***

- ✚ Electrical Fault: An electrical fault is defined as a condition in the electrical system that causes failure of the electrical equipment in the circuit such as: generators, transformers, cables and all other equipment in the system that operate at within defined voltage limits [4].
- ✚ Equipment Overloading: A circuit overload takes place when the amount of current flowing through the circuit exceeds the rating of the protective devices. Exceeding the rated load for the circuit will cause the circuit breaker to trip, shutting off the power of an entire region in the system. If there were no breakers in the circuit, an overload would cause the circuit wiring to overheat, which could melt the wire insulation and lead to a fire [5].

### ***About Capacitors:***

Series capacitors have very limited use in distribution systems. This is because of problems with its implementation. The installment of these requires a large amount of vast engineering investigation, so utilities often are reluctant to install series capacitors. Additionally, series capacitors have the particularity of providing considerably less correction to the power factor [6].

Unlike series capacitors, shunt capacitors are used very extensively in distribution circuits. Shunt capacitors supply the amount of reactive power or current necessary to counteract the inductive effect of a load. By installing shunt capacitors banks, the magnitude of the source current can be reduced, the power factor can be improved, and hence the voltage drop between the sending end and the load is also reduced [6].

Depending on the needs of a particular substation, fixed or automatically switched capacitor banks may be installed. There are two main types of power factor correction capacitors: fixed and automatic. Automatic capacitors also receive the name of switched capacitors. Automatic capacitors vary the amount of correction (KVAR) supplied to an electrical system, while fixed capacitors supply a constant amount of correction (KVAR) [6].

**Fixed Capacitors.** Fixed capacitor installations are those that are permanently on the line. These capacitor banks are connected to the system through a disconnecting device (i.e. switch). The importance of the switches is that they are capable of interrupting the capacitor current, allowing removal of capacitors for maintenance purposes. The use of fixed capacitor banks is recommended when a voltage boost to the system is required during heavy load periods [7].



Switched Capacitors. Switched capacitors are those where the capacitor bank is switched in and out of service, depending upon the needs of the system. Typically, these are switched on when the load requirements are the highest and switched off during light-load conditions. They can be switched on/off as a block or in several consecutive stages as the reactive load increases from light-load level to peak load and sized accordingly [7].

### ❖ EXPERIMENTAL PROCEDURE

Conductor line sizing is a critical step of designing a substation. The size of conductors chosen for this substation were designed to handle the rated current of the high and low voltage sides of the substation plus an additional a safety margin. The calculations below display the rated current of the high and low voltage sides for the substation, using the equations from reference [6]:

$$I_{Rated,HV} = \frac{S}{\sqrt{3}V_{LL}} = \frac{120MVA}{\sqrt{3} * (138kV)} = 502.08 \text{ Amps} \quad (1)$$

$$I_{Rated,LV} = \frac{S}{\sqrt{3}V_{LL}} = \frac{120MVA}{\sqrt{3} * (69kV)} = 1004.08 \text{ Amps} \quad (2)$$

The transmission line conductor size was selected to accommodate the above ratings plus a 30% safety margin for possibilities of load increment, voltage drop, and power losses. The conductor selections indicate that a bare 2500 kcmil all aluminum conductor was chosen for the 138kV high voltage side bus and a bare 1590 kcmil all aluminum conductor was chosen for the rest of the substation. The 2500kcmil AAC (all aluminum conductor) is rated for 1706 Amps and the 1590kcmil AAC is rated for 1333 Amps [8]. The 138kV high voltage side bus conductor size was selected to be much larger than the rest of the substation. The reason is that this bus will connect to several substations and other loads before it is terminated. The conductors chose are bare all aluminum stranded conductors. This design choice has numerous advantages. The bare conductors use the air around them as insulation. The stranded wires improve flexibility and increase the surface area of wires exposed to the air. This helps the conductor to cool down, and hence increases the conductivity. The chosen bare all aluminum conductor lines contribute the substation design be safe, reliable, and cost effective. Based on the above calculations, a conductor with similar ratings was chosen for the transmission lines in the substation.

## ❖ RESULTS

The drawing presented below is the completed one-line diagram on ETAP.

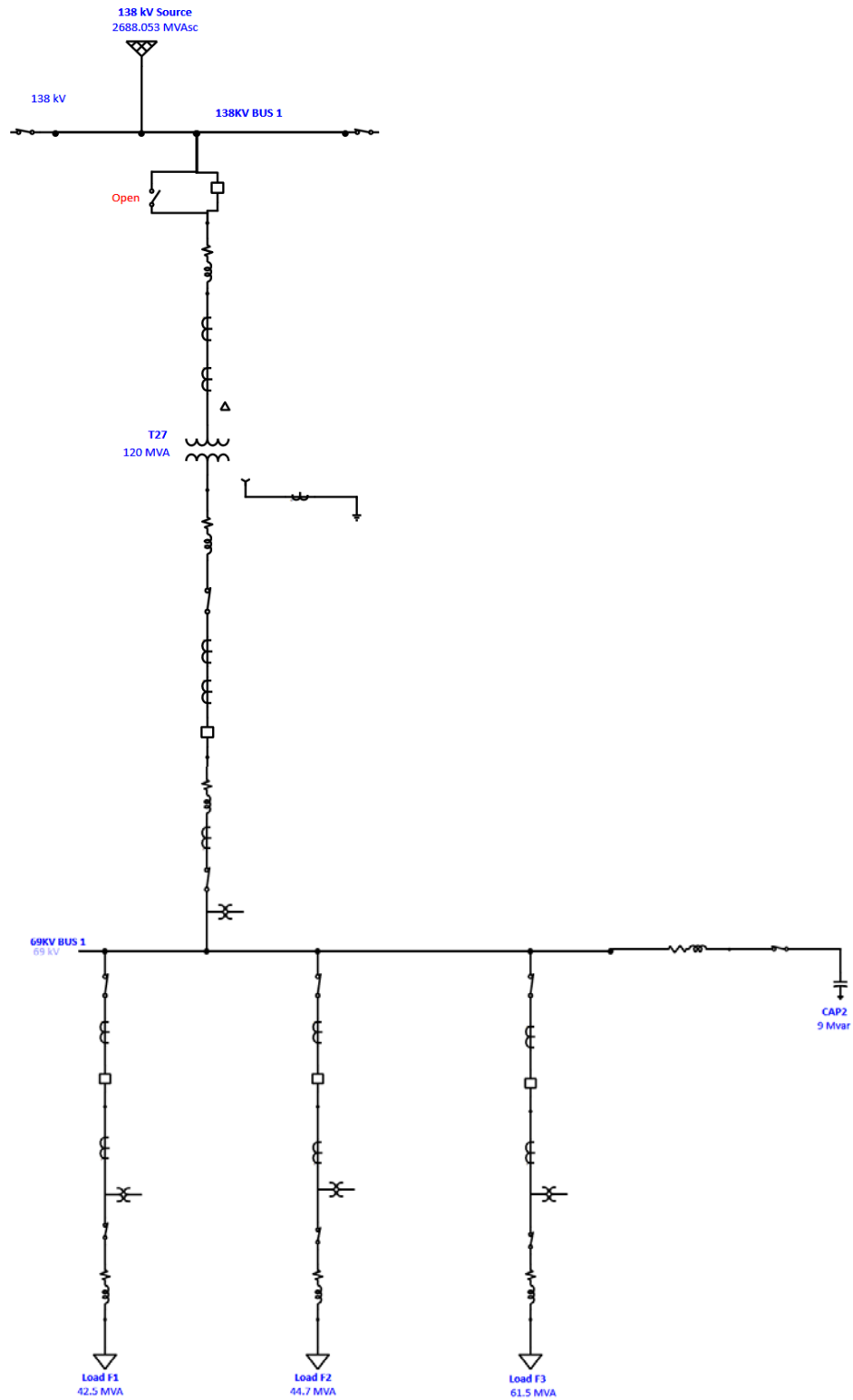

Fig. 1. Complete One-line Diagram.

With all the parameters filled out for each piece of equipment, the first load flow simulation is performed. For this simulation, the substation parameters given by Black & Veatch were applied. That includes the size of the capacitor bank and the ratings for all pieces of equipment. For the first scenario tested, the load power factor of one of the feeders is set to a particularly low power factor. The loads placed on the other two feeders were set to acceptable operating power factors. For substations with large inductive loads, the operating power factor normally ranges from 80% to 95% [6]. Table. 1. below displays the power factors (PF) used on each of the loads, for the first load flow simulation.

PF Feeder 1	PF Feeder 2	PF Feeder 3
0.94	0.89	0.60

Table. 1. Power Factor Assignment to Feeders for First Scenario.

### ***First Scenario – Testing the Current Size of Fixed Capacitor Bank***

My Senior Design project mentors from Black & Veatch suggested implementing a particularly low power factor of 0.60 on one of the loads. The objective of doing this, is to determine whether the size of the current capacitor bank (9 Mvar) is sufficient to have the voltage operating within permissible limits. Low power factors cause heavier current flow through the power distribution lines, which brings about increased power losses in the system [9].

	ID	kW	kvar	Amp	% PF	Vterminal
	Load F1	35421.5	12856.3	334.9	94	94.16
	Load F2	35273.2	18071	352.2	89	94.16
	Load F3	32716	43621.4	484.5	60	94.16

Fig. 2. Voltage Drop for 0.60 PF Inductive Load.

The table above summarizes the load flow results at the feeders. The results obtained in the first load flow scenario indicate that the feeders are under voltage. Fig. 3 below, shows that the voltage at the feeders is at 94.16% of the nominal voltage which is 69kV. In other words, a voltage drop of 5.84% of the nominal takes place at the feeders. This violates the National Standard for Utility Voltage Regulation called ANSI C84.1. It dictates that the voltage service range should always remain within  $\pm 5\%$  of nominal. This standard applies to any 60Hz electrical power system

above 100 Volts. This standard includes preferred voltage ratings up to 1,200kV maximum system voltage [10]. When voltages and currents deviate from nominal values, electrical faults can occur. Fault operating conditions cause damage to equipment and devices. Higher power factors are associated with improved and safer operating conditions [11].

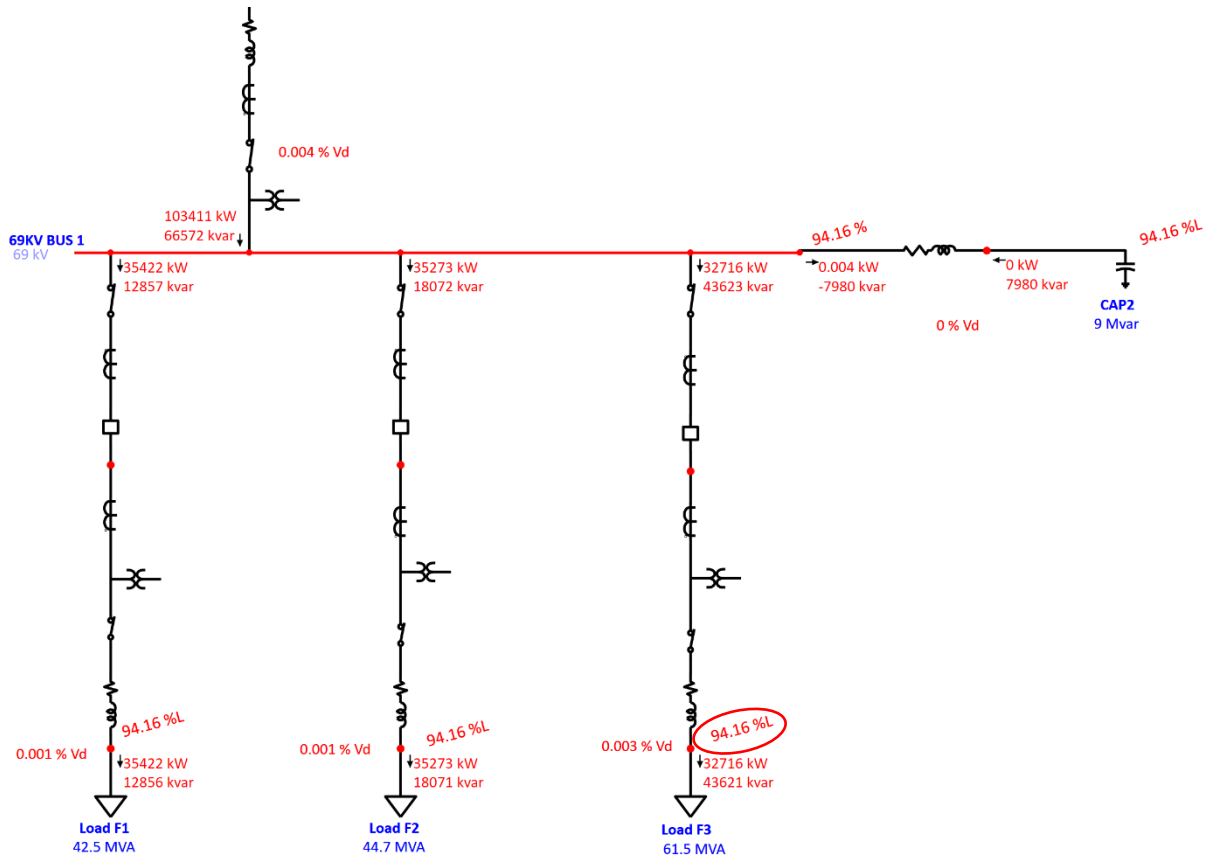

Fig. 3. Load Flow Simulation for Unchanged Conditions.

When running this simulation, the ETAP software also flagged the power transformer on the high voltage side of the substation. As displayed in the pictures as follows, the voltage through the power transformer is overloaded at 102.5%. ETAP highlights the overloaded transformer in red. During overloading scenarios, excess heat will cause the insulation system to break down, resulting in decreased life expectancy of the transformer [6]. This suggest that an optimization of the system is required.

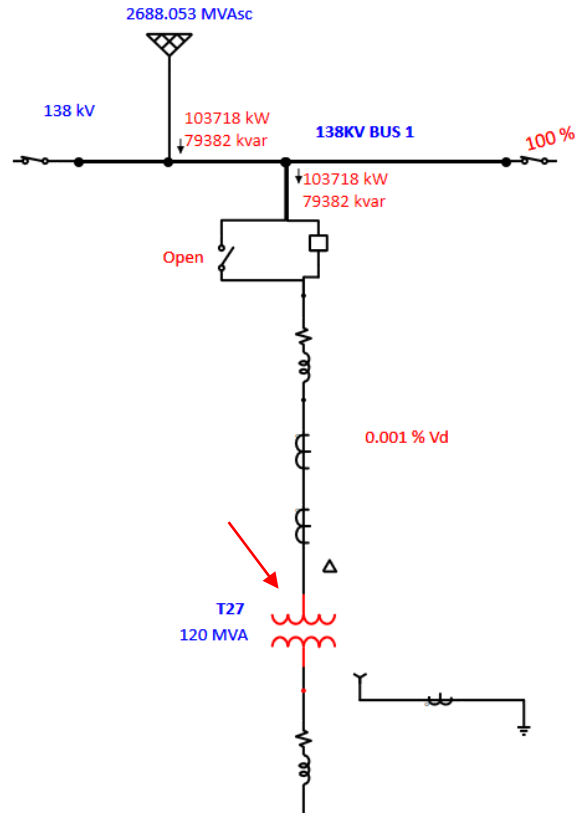

Fig. 4. Load Flow Simulation for Unchanged Conditions.

ID	Type	MW Flow	Mvar Flow	Amp Flow	% Loading	% Voltage Drop
T27	Transf. 2W	103.718	79.381	546.4	102.5	5.83

Fig. 5. Result Window Transformer Overloaded Warning.

It can be observed that introducing a load with a lagging power factor of 0.60 significantly drops the voltage on each of the feeders to about 64.97 kV. The change represents a decrease of 5.84% of the nominal voltage (69kV). All of the feeders have the same configuration and parameters, and are connected in parallel. For this reason, the voltage reading through each of them is the same. The percentage voltage drop observed to the left of each feeder corresponds to voltage change through the transmission line. In the same way, the reading of real and reactive power consumed by the load is displayed to the right of each feeder. The results from the simulation indicate that the size of the capacitor bank is not large enough to compensate the inductive effect of the loads.

As explained in the book *Electrical Power Distribution Engineering* by Gonen, shunt capacitors can be used to control the voltage drop in the system caused by inductive loads [6]. In particular, shunt capacitor banks are widely used to improve the power factor in the network. At the same time, they improve voltage stability and reduce network losses. Improving the power factor also results in a higher power transmission capability and improved control of the power flow [6]. To optimize the system's voltage stability, the approach of modifying the size of the existing fixed capacitor bank. The goal of performing this change is to bring up the voltage level at the loads and try to correct the overloading at the transformer.

To determine the size of the fixed capacitor bank that brings up the voltage up within  $\pm 5\%$  of the nominal voltage, the following procedure is followed. The values to be plugged in into the equations below are the those obtained in the load flow results in Fig. 3. The desired power factor displayed is a choice of the designer, and this can be changed according to the requirements of the system.

In the equations as follows [6],

$P_n$  stands for the real power losses (kW)

$Q_n$  stands for the reactive power losses (kVAR)

$Q_{source}$  is the reactive power magnitude at the source

$Q_{C,Fixed}$  denotes the size of the fixed shunt capacitor bank

$Q_{C,Switch}$  denotes the size of the switched capacitor bank

$n$  denotes the nodes of the section being analyzed

- **Fixed Shunt Capacitor Bank Calculations [6]:**

$$PF_{Desired} = 0.95$$

$$P_{Min,Total} = \sum_{n=1}^{n=5} P_n = \sum_{n=1}^{n=5} (35,422 + 35,273 + 32,716 + 103,411 + 0.004) = 206,822 \text{ kW}$$

$$Q_{Min,Total} = \sum_{n=3}^{n=5} Q_n = \sum_{n=1}^{n=5} (12,856 + 18,071 + 43,621 + 66,572 - 7,980) = 133,140 \text{ kVar}$$

$$Q_{Source} = P_{Min,Total} \tan(\cos^{-1} PF_{Desired}) = (206,822 \text{ kW}) \tan(\cos^{-1} 0.95) = 67,979 \text{ kVar}$$

$$Q_{C,Fixed} = Q_{Min,Total} - Q_{Source} = 133,140 \text{ kVar} - 67,979 \text{ kVar} = 65,161 \text{ kVar}$$

*Capacitor Bank: 65,161 kVar*

After updating the new size of capacitor bank into the one-line diagram, the simulation is run one more time. The results show that this modification improved the voltage reading at the terminals, being closer to the nominal bus voltage. The voltage at the feeders is now 98.04% of the nominal voltage, which represents a 67.65kV. By increasing the size of the fixed capacitor bank, the power factor in the system was corrected. The higher the power factor, the smaller the overall system losses and the better performance of the system. Fig. 6 below displays the results for the load flow with the resized capacitor bank and the improved voltage profile.

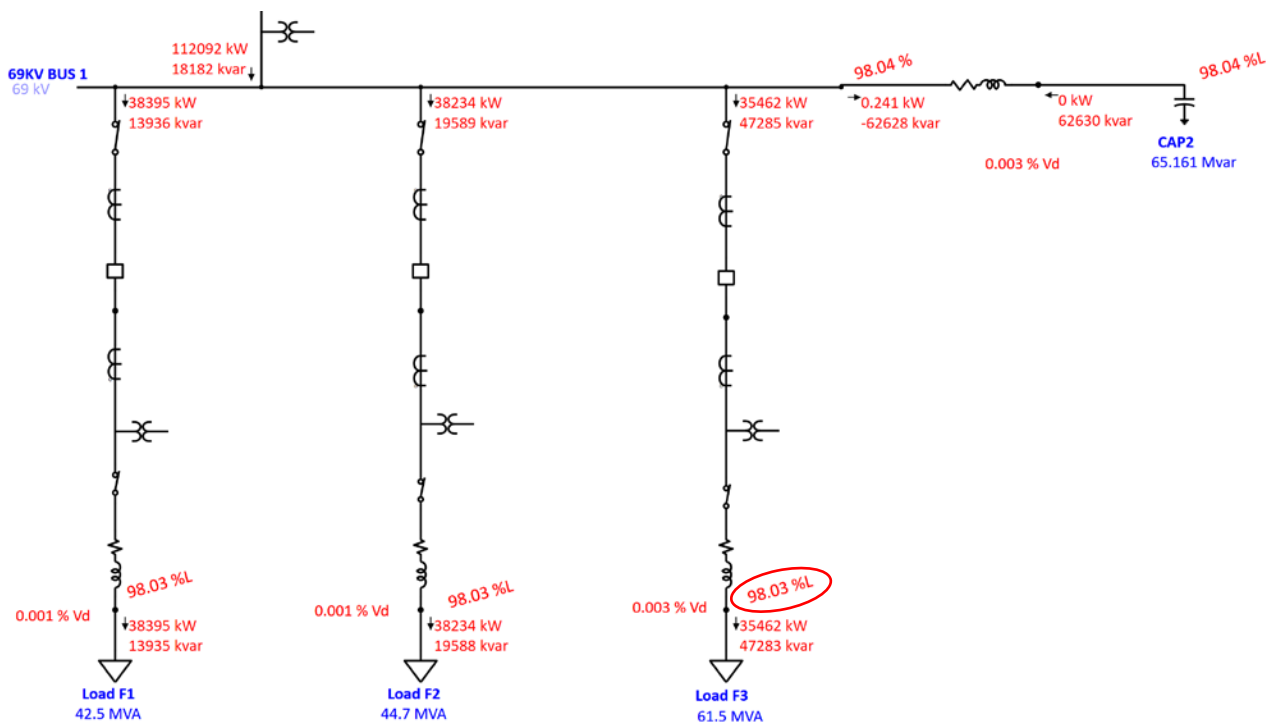

Fig. 6. Power Factor Correction by Increasing Size of Fixed Capacitor Bank.

ID	kW	kvar	Amp	% PF	Vterminal
Load F1	38394.7	13935.4	348.6	94	98.03
Load F2	38234	19587.8	366.7	89	98.03
Load F3	35462.1	47282.9	504.5	60	98.03

Fig. 7. Result Window for Feeders with Resized Fixed Capacitor Bank.

As Fig. 7 verifies, the resizing of the fixed shunt capacitor bank indeed compensates for the inductive effect in the voltage profile.

The results of the load flow analysis for the complete one-line diagram are displayed as follows.

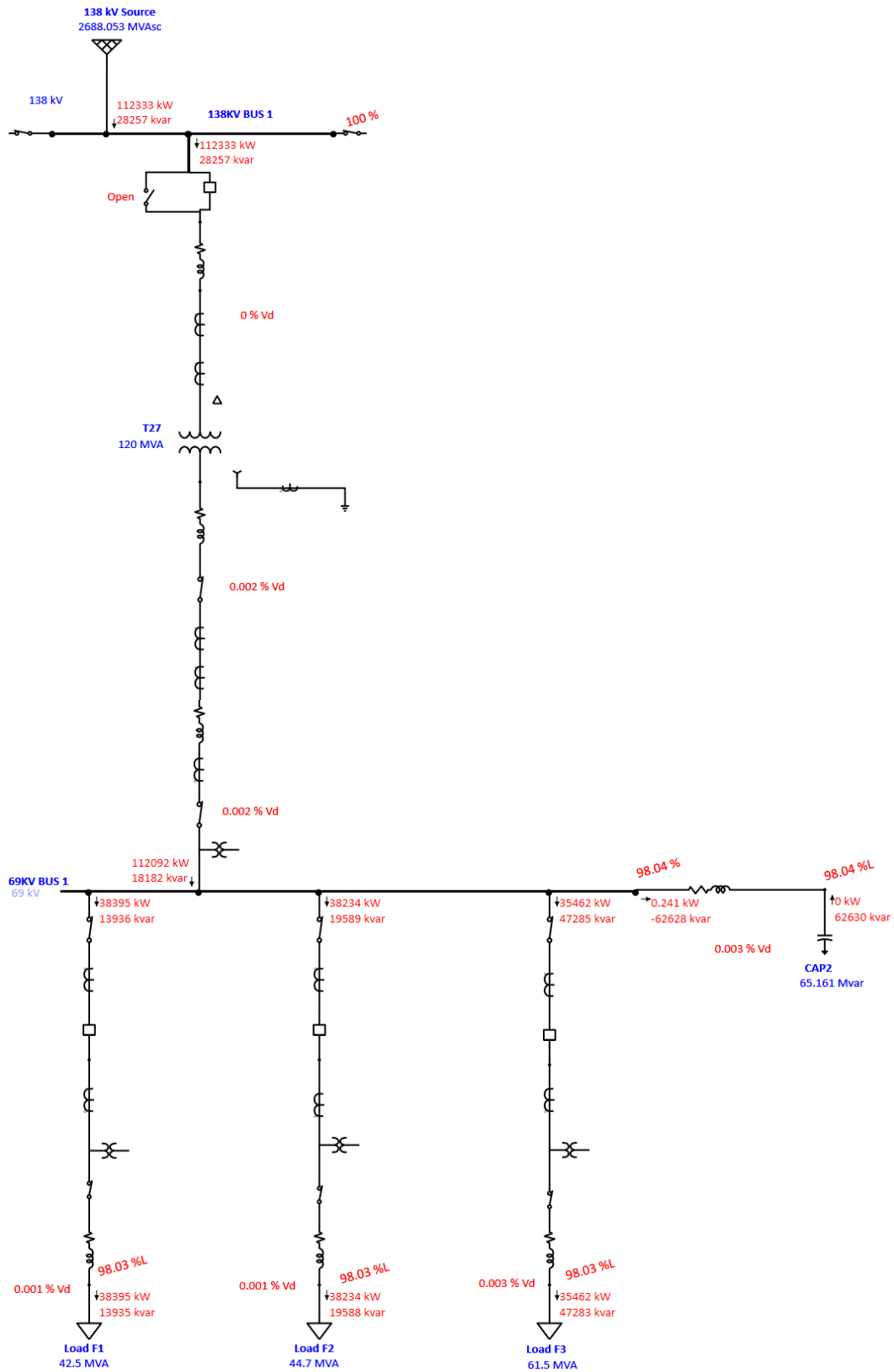

Fig. 8. Load Flow Results with Resized Fixed Shunt Capacitor Bank.



It can be commented that this improvement in the power factor, resulted in the overloading warning for the power transformer in the high voltage side to disappear. The results window for the transformer is displayed below.

ID	Type	MW Flow	Mvar Flow	Amp Flow	% Loading	% Voltage Drop
T27	Transf. 2W	112.333	28.256	484.6	94.6	1.96

Fig. 9. Result Window for Power Transformer without Overloading Warning.

It is worth recalling that the capacitor bank on the bus is a fixed. That means that its reactive effect on the network is permanent. Fixed capacitors supply a constant amount of reactive correction (kVAR). In other words, a fixed capacitor is a type of capacitor that stores fixed amount of electric charge which is not adjustable. Now, it is of critical importance to take into consideration what happens when the system is not operating at peak load and the power factor is close to 1. When the power factor at the loads is close to 1, reactive compensation of the capacitor bank is not required at that instance.

***Second Scenario – PF at the feeders is close to 1***

The placement of the fixed capacitors in the distribution lines, sometimes encounters the problem of overcompensation when the reactive power demand reduces. This occurs as the fixed capacitors are placed for a particular calculated load to give the line reactive power compensation for the existing load. In this scenario, the system is not operating at peak loads, so the power factor is close to 1.

The simulation performed as follows is used to determine the impact of the fixed capacitor bank on the voltage profile when the PF at the loads is close to 1. The power factor assignment for the feeders is displayed in Table 2. When testing this scenario, it can be observed that the voltage increases to 73.91 kV. This represents 7.1% higher voltage than the permissible operating limit that is  $\pm 5\%$  of the nominal.

PF Feeder 1	PF Feeder 2	PF Feeder 3
0.99	0.985	0.99

Table. 2. Power Factor Assignment to Feeders for Second Scenario.

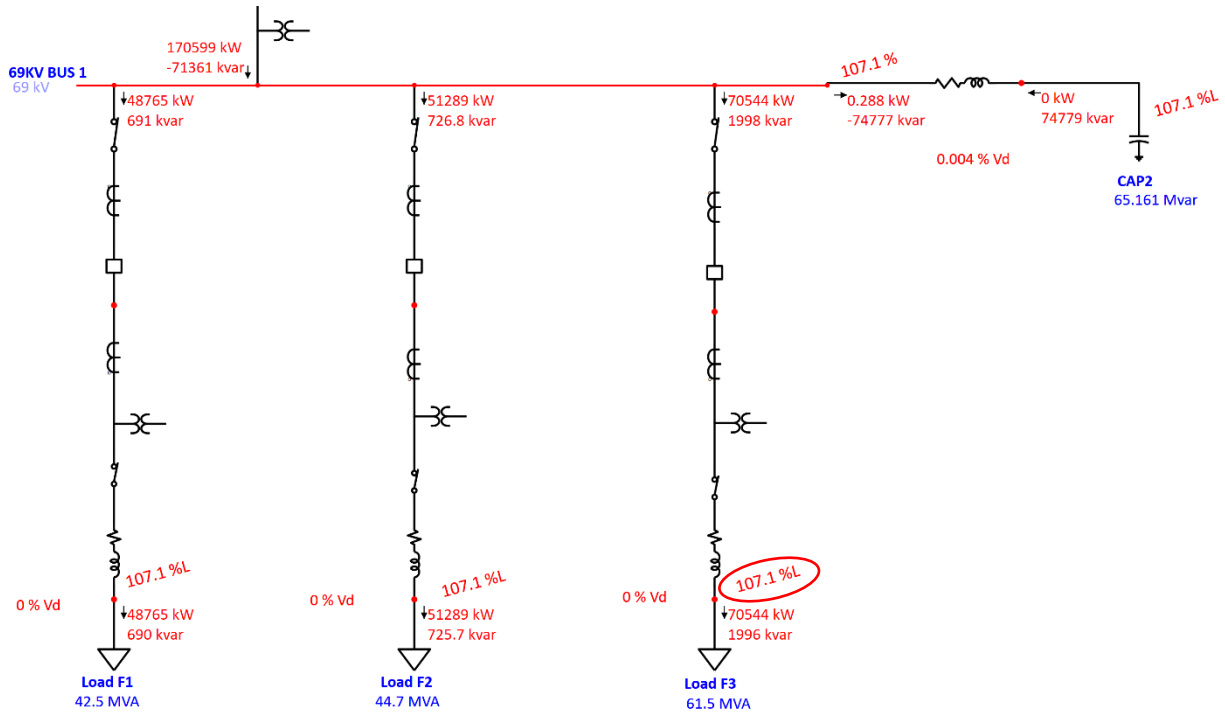

Fig. 10. Load Flow When PF Is Close to 1 for Fixed Shunt Cap Bank.

The over voltage problem can be corrected by replacing the fixed capacitor bank with a switched capacitor bank. The size of the switched shunt capacitor can be determined by substituting the values obtained in the simulations into the power flow equations shown below. After implementing this change, the voltage reading at each of the feeders falls within the  $\pm 5\%$  voltage regulation standards. The calculations required to obtain the minimum size of switched capacitor bank, so that it operates within  $\pm 5\%$  of the rated voltage are as follows:

- **Switched Shunt Capacitor Calculations [6]:**

$$PF_{Desired} = 0.95$$

$$P_{Min,Total} = \sum_{n=1}^{n=5} P_n = \sum_{n=1}^{n=5} (35,422 + 35,273 + 32,716 + 103,411 + 0.004) = 206,822 \text{ kW}$$

$$Q_{Min,Total} = \sum_{n=3}^{n=5} Q_n = \sum_{n=1}^{n=5} (12,856 + 18,071 + 43,621 + 66,572 - 7,980) = 133,140 \text{ kVar}$$

$$Q_{Source} = P_{Min,Total} \tan(\cos^{-1} PF_{Desired}) = (206,822 \text{ kW}) \tan(\cos^{-1} 0.95) = 67,979 \text{ kVar}$$

$$Q_{C,Fixed} = Q_{Min,Total} - Q_{Source} = 133,140 \text{ kVar} - 67,979 \text{ kVar} = 65,161 \text{ kVar}$$

$$Q_{C,Total} = Q_{Peak,Total} - Q_{Source} = 143,440 \text{ kVar} - 67,979 \text{ kVar} = 75,461 \text{ kVar}$$

$$Q_{C,Switch} = Q_{C,Total} - Q_{C,Fixed} = 75,461 \text{ kVar} - 65,161 \text{ kVar} = 10,300 \text{ kVar}$$

Capacitor Bank: 10,300 kVar

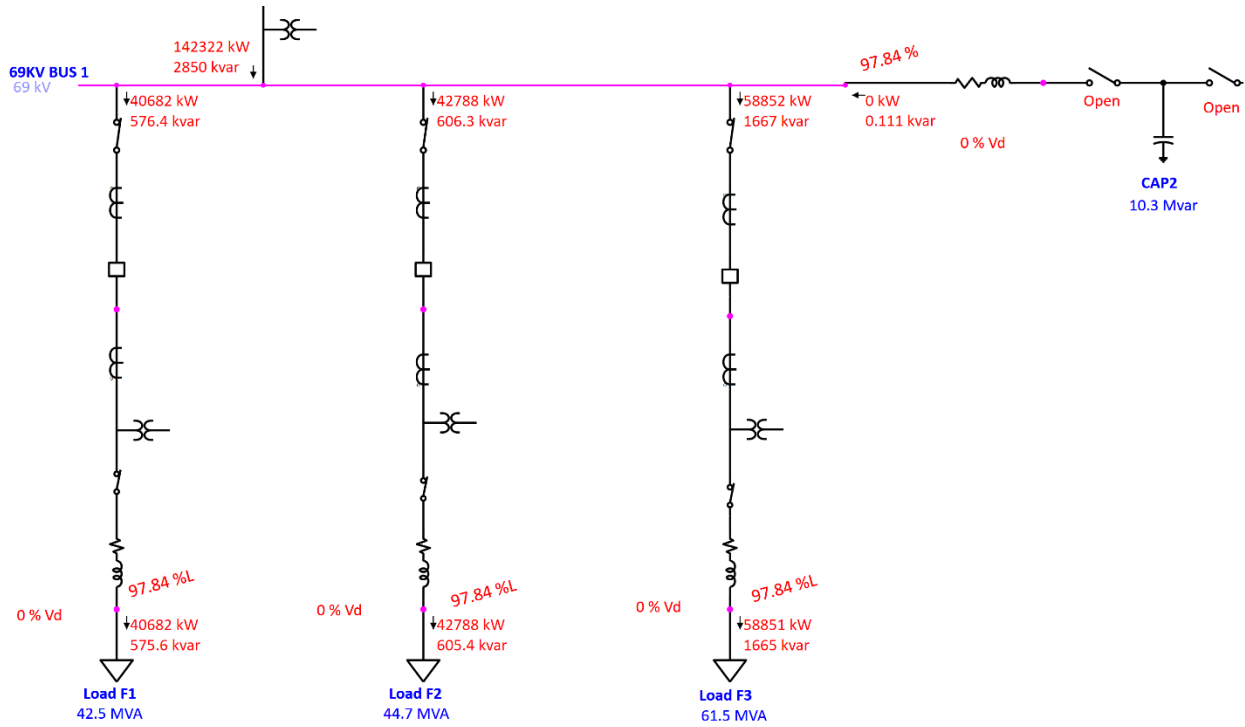

Fig. 11. Installation of Switched Capacitor Bank (Open Switch).

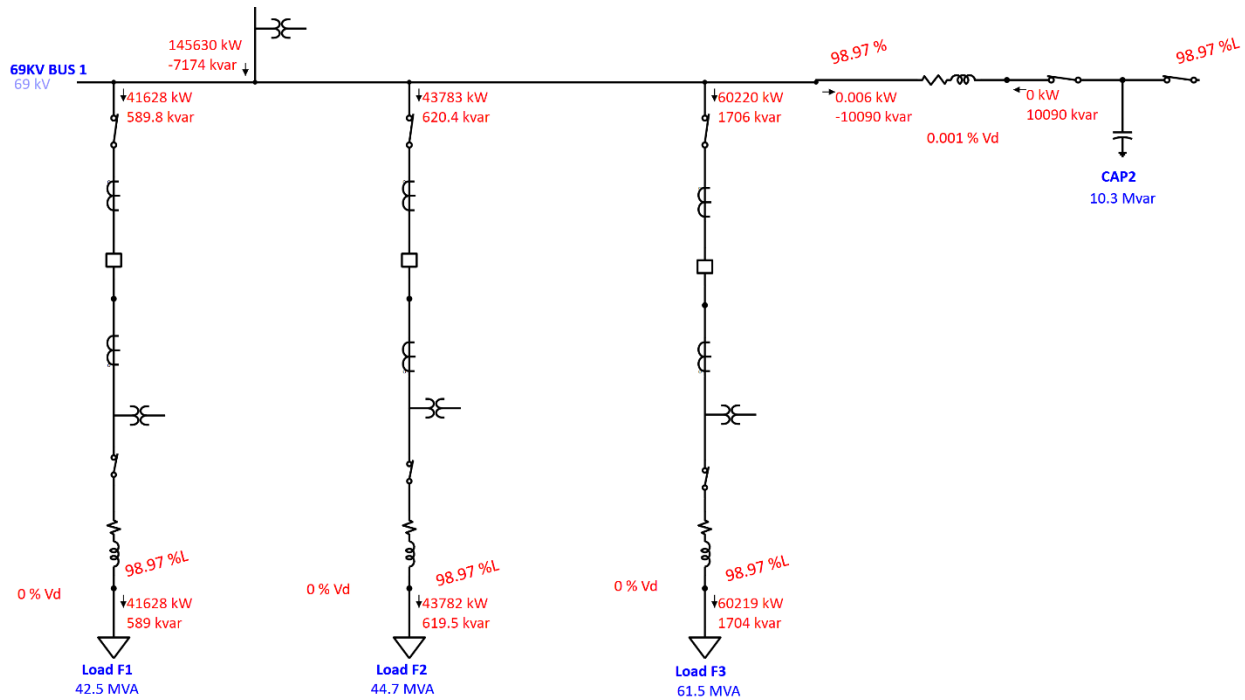

Fig. 12. Installation of Switched Capacitor Bank (Closed Switch).

It can be concluded that replacing the fixed capacitor bank with the switched capacitor bank is suitable when the loads are not operating at peak load. This means that the inductive effect of the loads is very little, and so the power factor of the loads is close to 1. As the results illustrate,

switched capacitors can be switched on/off as a block or in several consecutive stages as the reactive load increases from light-load level to peak load and sized accordingly. This is one of the fundamental advantages of switched capacitor banks. Fig. 13 below displays the internal configuration of a switched shunt capacitor.

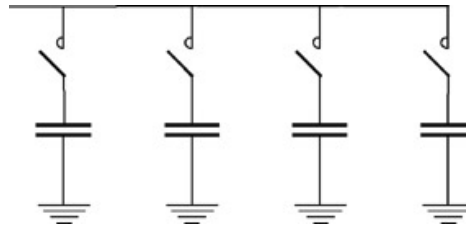

Fig. 13. Internal Configuration of a Switched Shunt Capacitor Bank [12].

If only fixed-type capacitors were implemented, the utility would experience an excessive leading power factor and voltage increment the feeders as verified before in Fig. 11. From this information, the following conclusion can be drawn. If the utility has a fixed demand of power and constant power factors at the loads, fixed capacitor banks could be a good choice (static loads). In contrast, if the utility has a large plant with varying load PFs, a switched capacitor would be a better option (dynamic loads).

The implementation of a voltage regulator to the system was considered. Nevertheless, the drawing corresponding to this piece of equipment was not available on ETAP. So, the effect of this device could not be demonstrated with simulations. Despite this fact, it is worth mentioning the effect of voltage regulator in the performance of the system. Voltage regulators are often implemented both at the substation and out on distribution lines to help maintain a constant voltage level along the feeders. Their operation consists on automatically regulating voltage changes, trying to maintain a constant voltage level. They raise or lower the voltage on the distribution lines to as the amount of load on the line changes [6].

Incorporating a voltage regulator to the system would be advantageous, since they minimize variations in voltage in order to protect the equipment using the electricity. In power-distribution systems, the regulators may be placed at the substations or on the feeder lines themselves. Two common types of regulators are used: step regulators, in which switches normalize the current supply, and induction regulators, in which an induction motor supplies a

secondary, constantly adjusted voltage to even out current variations in the feeder line [13]. It can be mentioned that a fixed capacitor is not a voltage regulator and cannot be directly compared to regulators. Nevertheless, in some instances, automatically switched capacitors can replace conventional step-type voltage regulators for voltage control on distribution feeders [6].

## ❖ CONCLUSION

Through this paper, the load flow analysis of a 138/69kV substation was examined for different operating scenarios using ETAP. The results obtained from load flow study were used to make pertinent adjustments to improve the system's performance. Different approaches for power factor corrections were examined, and considerations to keep in mind before any addition or modification to the system were discussed. It is important to highlight that the ETAP simulation results confirmed that the introduction of strategically sized and positioned shunt capacitors within the distribution system, helps to counteract losses due to inductive elements and improves the voltage profile of the network. It can be argued that the investment on fixed and switched capacitors comes with numerous technical and financial benefits. These benefits include power loss reduction, improved voltage stability, reducing equipment loading, and postponement in costly network upgrades. All in all, the load flow analysis is of critical importance for ensuring an optimal system performance and for preventing power outages.

## ❖ REFERENCES

- [1] O. M. Fahmy, "Analysis of Existing Power Flow Case for South Operating Area Network," 2016 *Saudi Arabia Smart Grid (SASG)*, Jeddah, 2016, pp. 1-10. doi: 10.1109/SASG.2016.7849666
- [2] K. Tilakul, P. Buasri, A. Kaewrawang and J. Triyangkulsri, "Capacitor Location and Size Determination to Reduce Power Losses of a Distribution Feeder in Lao PDR," *International Journal of Computer and Electrical Engineering*, pp. 32-36, 2012. Available: 10.7763/ijcee.2012.v4.447.
- [3] "Understanding The Power Factor - Laurens Electric Cooperative", *Laurens Electric Cooperative*, 2019. [Online]. Available: <https://www.laurenselectric.com/home/business/understanding-power-factor/>.
- [4] "Faults in Electrical Systems (back to basics)", Electrical engineering Community, 2019. [Online]. Available: <http://engineering.electrical-equipment.org/electrical-distribution/faults-in-electrical-systems-back-to-basics.html>
- [5] Jamil, M. and Sharma, A., "Reconfiguration of Electrical Distribution System Using ACO Methodology," pp. 1-8, 2018.
- [6] T. Gonen, *Electric Power Distribution Engineering, Third Edition*. Abingdon: CRC Press, 2014.
- [7] "IEEE Guide for the Application of Shunt Power Capacitors", *Ieeexplore.ieee.org*, 2019. [Online]. Available: <https://ieeexplore.ieee.org/stamp/stamp.jsp?arnumber=5703189>.
- [8] "All Aluminum Conductor AAC", *Priority Wire & Cable*, 2018. [Online]. Available: <http://www.prioritywire.com/specs/AAC%20All%20Aluminum%20Conductor.pdf>.
- [9] "Understanding The Power Factor - Laurens Electric Cooperative", *Laurens Electric Cooperative*. [Online]. Available: <https://www.laurenselectric.com/home/business/understanding-power-factor/>.
- [10] "American National Standard for Electric Power Systems and Equipment—Voltage Ratings (60 Hz)", *Nema.org*, 2019. [Online]. Available: <https://www.nema.org/Standards/Pages/American-National-Standard-for-Electric-Power-Systems-and-Equipment-Voltage-Ratings.aspx>.
- [11] "Faults in Electrical Systems (back to basics)", *Electrical engineering Community*, 2019. [Online]. Available: <http://engineering.electrical-equipment.org/electrical-distribution/faults-in-electrical-systems-back-to-basics.html>.

- [12] "Capacitor Bank Protection", *IEEE Global Spec - Engineering 360*. [Online]. Available: <https://www.globalspec.com/reference/74820/203279/10-6-capacitor-bank-protection>.
- [13] "Voltage Regulator | Electronics", *Encyclopedia Britannica*, 2019. [Online]. Available: <https://www.britannica.com/technology/voltage-regulator>.