

4-1-1979

# Study of Cumulative Growth-Inhibiting Factors in Recycled Water for Catfish Cultivation

R. W. Raible

*University of Arkansas at Little Rock*

Follow this and additional works at: <https://scholarworks.uark.edu/awrcctr>

 Part of the [Fresh Water Studies Commons](#), and the [Water Resource Management Commons](#)

---

## Recommended Citation

Raible, R. W.. 1979. Study of Cumulative Growth-Inhibiting Factors in Recycled Water for Catfish Cultivation. Arkansas Water Resources Center, Fayetteville, AR. PUB064. 45

This Technical Report is brought to you for free and open access by the Arkansas Water Resources Center at ScholarWorks@UARK. It has been accepted for inclusion in Technical Reports by an authorized administrator of ScholarWorks@UARK. For more information, please contact [scholar@uark.edu](mailto:scholar@uark.edu), [ccmiddle@uark.edu](mailto:ccmiddle@uark.edu).

**STUDY OF CUMULATIVE  
GROWTH-INHIBITING FACTORS  
IN RECYCLED WATER FOR CATFISH CULTIVATION**

by

R.W. Raible

Principal Investigator

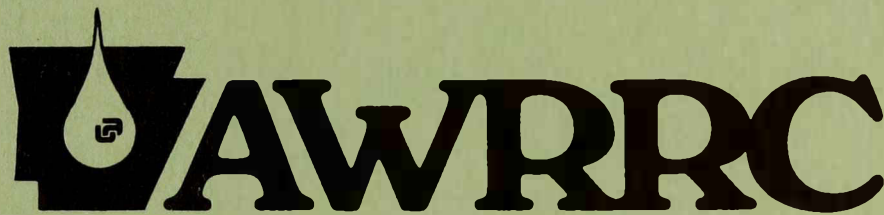

**Arkansas Water Resources Research Center**

University of Arkansas  
Fayetteville , Arkansas

for work performed at  
Department of Electronics and Instrumentation  
Graduate Institute of Technology  
Little Rock, Arkansas

Publication No. 64

1979



## DISCLAIMER

Contents of this publication do not necessarily reflect the views and policies of the Office of Water Research and Technology, U. S. Department of the Interior; nor does mention of trade names or commercial products constitute their endorsement or recommendation for use by the U. S. Government.

## ABSTRACT

Channel catfish were grown in tanks with integral biological filters and complete recirculation of water. After the fish had resided in the tanks for 120 days, solvent extraction was performed on a portion of the tank water. Fresh pond-raised specimen channel catfish showed decreases in their heartbeat rates of about 20 percent when exposed to the extract. This metabolic disturbance is thought to be a factor in reducing the growth rate of fish held in close confinement in recirculating systems.

## TABLE OF CONTENTS

DISCLAIMER . . . . .	ii
ABSTRACT . . . . .	iii
LIST OF FIGURES . . . . .	v
LIST OF TABLES . . . . .	vi
ACKNOWLEDGEMENTS . . . . .	vii
I. INTRODUCTION . . . . .	1
II. FISH CULTIVATION EQUIPMENT . . . . .	4
A. General System Design . . . . .	4
B. Biological Filtration . . . . .	10
III. EXPERIMENTAL EQUIPMENT AND PROCEDURES . . . . .	14
IV. RESULTS . . . . .	24
V. CONCLUSIONS . . . . .	33
REFERENCES . . . . .	36

## LIST OF FIGURES

1.	Photograph of the eight closed systems used for catfish cultivation . . . . .	5
2.	Diagram of the top view of the closed system . . . . .	7
3.	View of the main-filter side of the closed system . . . . .	8
4.	View of the pump end of the closed system . . . . .	9
5.	Concentration of un-ionized ammonia compared with the rate of ammonia and nitrite reduction . . . . .	16
6.	Location of hooks used as electrodes at pectoral girdle of catfish . . . . .	20
7.	Block diagram of the electronic system for amplifying, filtering, and recording the heartbeat rate . . . . .	21
8.	Schematic diagram of the active filter . . . . .	22
9a.	Heartbeat rate with recorder tuned to remove the opercular rate . . . . .	25
9b.	Heartbeat rate per minute with the opercular rate visible . . . . .	25

LIST OF TABLES

I.	Hardening Chemicals . . . . .	12
II.	Effect on Heart Rate of Channel Catfish Produced by Exposure to Extract No. 1 Taken from Tank No. 2 on April 27, 1977. . . . .	26
III.	Effect on Heart Rate of Channel Catfish Produced by Exposure to Extract No. 2 Taken from Tank No. 5 on April 27, 1977. . . . .	27
IV.	Effect on Heart Rate of Channel Catfish Produced by Exposure to Extract No. 3 Taken from Tank No. 8 on April 27, 1977. . . . .	28
V.	Effect on Heart Rate of Channel Catfish Produced by Exposure to Extract No. 4 Taken from Tank No. 1 on June 27, 1977. . . . .	29
VI.	Effect on Heart Rate of Channel Catfish Produced by Exposure to Extract No. 5 Taken from Tank No. 6 on June 27, 1977. . . . .	30
VII.	Effect on Heart Rate of Channel Catfish Produced by Exposure to Extract No. 6 Taken from Tank No. 8 on June 27, 1977. . . . .	31
VIII.	Heart Rate of Channel Catfish in Control Experiment During Which Extract Was Not Used . . . . .	32



## ACKNOWLEDGEMENTS

The Principal Investigator is grateful for the assistance provided by Mr. Leroy Gray, University of Arkansas Extension Fish and Wildlife Biologist; Mr. Dewey Tackett, Chemist at the Stuttgart Warmwater Fish Culture Laboratories, Stuttgart, Arkansas; and Dr. William Simco, Associate Professor of Biology at Memphis State University, Memphis, Tennessee. The work of the following in the experimental program also is deeply appreciated: Philip S. H. Hui, graduate research assistant, and Peggy Roberson, research assistant.

## I. INTRODUCTION

Fish are recognized as an increasingly important source of protein in human diet for medical and economic reasons. However, the world's natural supply of fish is decreasing as fish harvesting increases. As standards of living rise throughout the world, the available natural supply of fish cannot meet the demand. Therefore, recent years have seen an increasing interest in the domestic cultivation of fish. There can be little doubt that domestic fish cultivation will continue to increase.

Two major water-quality problems are posed by the increasing interest in fish cultivation. Contaminants produced by the growing fish in ponds, tanks, or raceways must be controlled to protect nearby ground and surface water from contamination. Also, successful aquaculture requires the maintenance of the water within the cultivation system in a sufficiently "clean" state to support maximal growth of the fish.

Considerable interest has evolved in cultivating catfish in confined and controlled systems, with emphasis on efficient feed conversion. Raceway culture requires a constant, large flow of water through the raceway; and the contaminated effluent poses a problem of water treatment. In comparison, closed-system culture allows water reuse. The only water supply needed in a closed

system during the growth cycle is that used to replace evaporation losses. In addition, closed systems eliminate the problem of controlling effluents because the contaminants are retained within the system. However, the constant reuse of water within a closed system compounds the difficulty of maintaining the requisite water quality for maximal fish growth.

During the course of a previous study at the University of Arkansas Graduate Institute of Technology,<sup>1</sup> several stockings of channel catfish (Ictalurus punctatus) were cultivated successively in closed systems in which all the known variables affecting growth rate were controlled. The successive stockings produced successively lower percentages of weight gained. The purpose of the current project, therefore, was to determine whether water recycled for the cultivation of channel catfish in closed systems accumulates factors that inhibit the growth of the catfish.

In the course of aquarium culture of exotic fish, it is common to observe that fish in a crowded aquarium are stunted; but the same fish grow to much larger sizes when allowed a large living space.<sup>2</sup> One reason for growth variations may be the presence of growth inhibitors produced by the fish living in crowded conditions. Experiments performed with carp, goldfish, zebrafish, and blue gourami have demonstrated serious reductions of the heartbeat rate for carp and goldfish caused by an extract from crowded fish tanks.<sup>3-5</sup> The extracts appeared to be species selective. Depression of the heartbeat rate was chosen for the experiments described below as a measure of the possible

accumulation of growth-inhibiting substances in a closed system over an extended period of time.

Difficulty in isolating and analyzing undesirable compounds in water recirculated for fish culture may be experienced for two reasons. First, numerous compounds are produced in the course of fish culture, making identification of any one of them difficult. Second, the compound of interest may be present only in very small quantities while still having a substantial effect on the fish. Fish metabolism has been shown to be sensitive to extremely small quantities of poisonous substances.<sup>6</sup> In addition, fish seem to be able to concentrate such substances (e.g., pesticides) in their tissues to an amazing degree.<sup>7</sup>

## II. FISH CULTIVATION EQUIPMENT

Eight similar water-recirculating systems (Figure 1) were used as the habitats for the channel catfish studied during this project. Each of the eight closed systems was independent of the others, and each contained its own biological filter.

### A. General System Design

The basic component of each of the eight systems was a double-tank container made of fiberglass. Each of the two tanks was 183 cm long, 61 cm wide, and 76 cm deep. Each tank was watertight, permitting cultivation of the catfish in one tank with no uncontrolled crossover to the filtration system in the other tank. A smaller tank (61 cm x 91 cm x 61 cm) was positioned above the double tank to provide an auxiliary filtration area. This auxiliary filter was added in earlier tests when it was determined that the main filter was too small to accommodate the fish at the end of a 6-month growth period. However, the auxiliary filter was operated continuously, regardless of the size of the fish in the system. The total water capacity of each system was approximately 1710 l, with the fish-cultivation tank being maintained at 684 l of water.

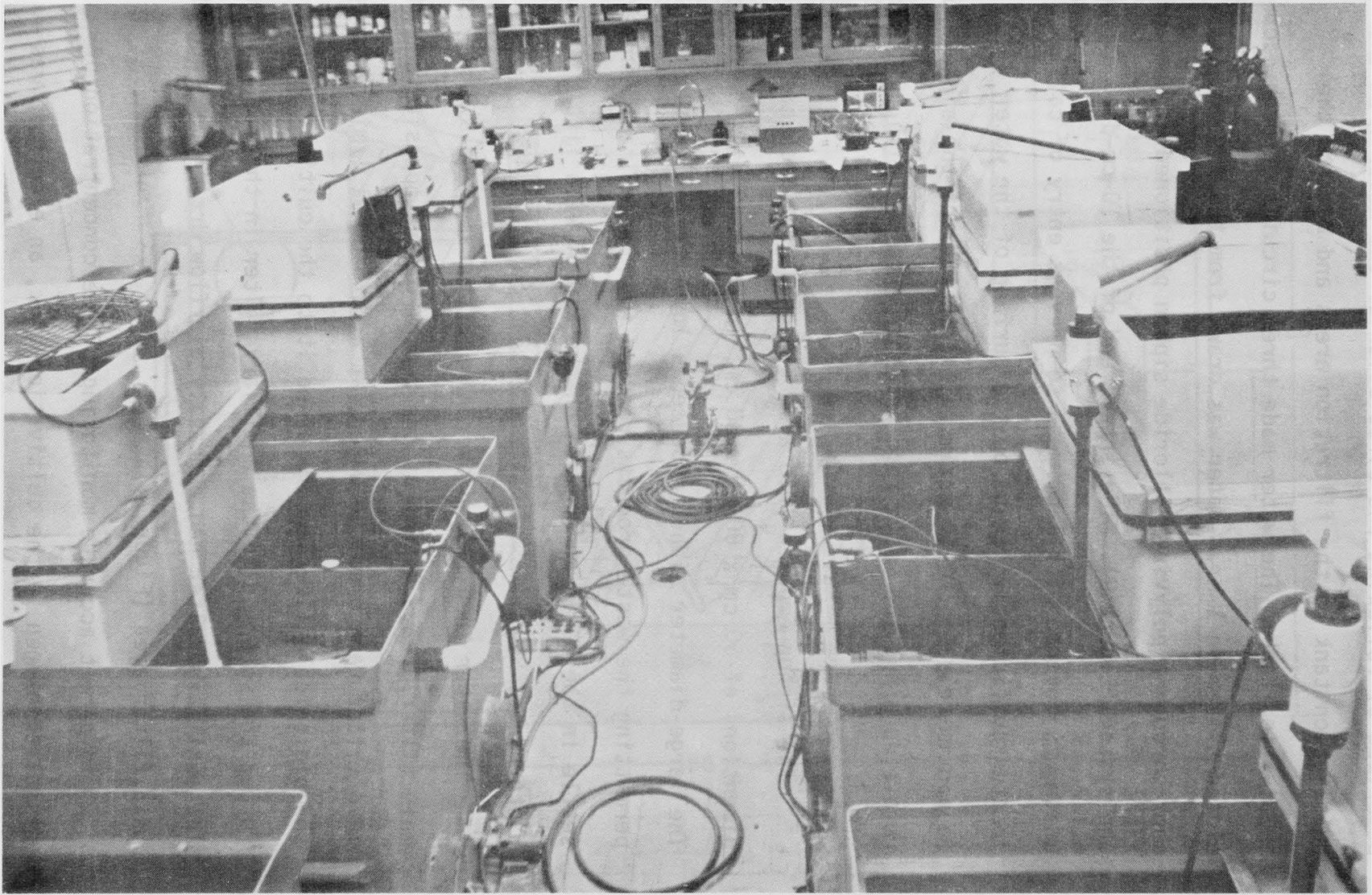

Fig. 1. Photograph of the eight closed systems used for catfish cultivation.

The general design of each of the eight closed systems can be described by following the circulation of the water from the cultivation tank to the filtration areas and back to the cultivation tank. The water made three circuits through each closed system in 1 hr. Water was drawn from the fish cultivation tank through a polyvinyl chloride siphon positioned at one end of the system (Figure 2). The intake end of the 10-cm-dia. siphon, which was covered with 1-cm mesh to prevent entry of catfish, was located sufficiently far below the surface of the water (approximately 46 cm) to maximize the ability of the siphon to remove detritus and waste food products from the fish cultivation tank.

The siphon emptied into a settling basin, which had dimensions of 60 cm x 60 cm x 30 cm, in the main filtration tank. The large-diameter siphon produced a low water velocity, permitting the waste products removed from the cultivation tank to settle in the basin and remain on the bottom with little disturbance.

The water then flowed over a partition (Figure 3) into the main filter area. A pump at the bottom of the opposite end of the main filter tank drew the water, at a rate of 91 l/min, through the biological filter and returned it to the cultivation tank or forced the water up to the auxiliary filter in the smaller tank. The auxiliary filter had a gravity overflow drain back into the main filter area (Figure 4).

To permit accurate monitoring of the concentration of dissolved oxygen in the cultivation tank, an electrode was

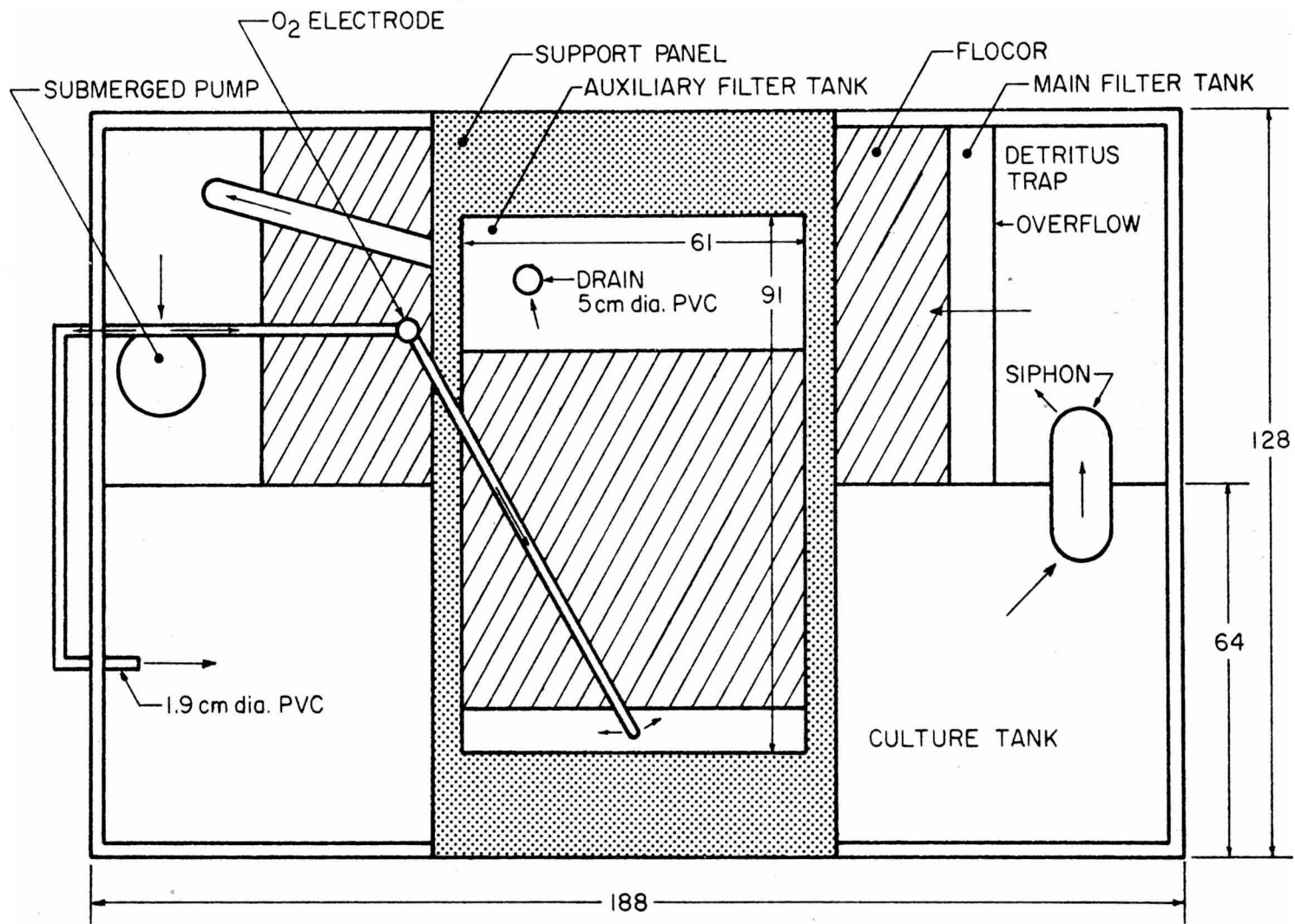

Fig. 2. Diagram of the top view of the closed system. All dimensions are in centimeters.



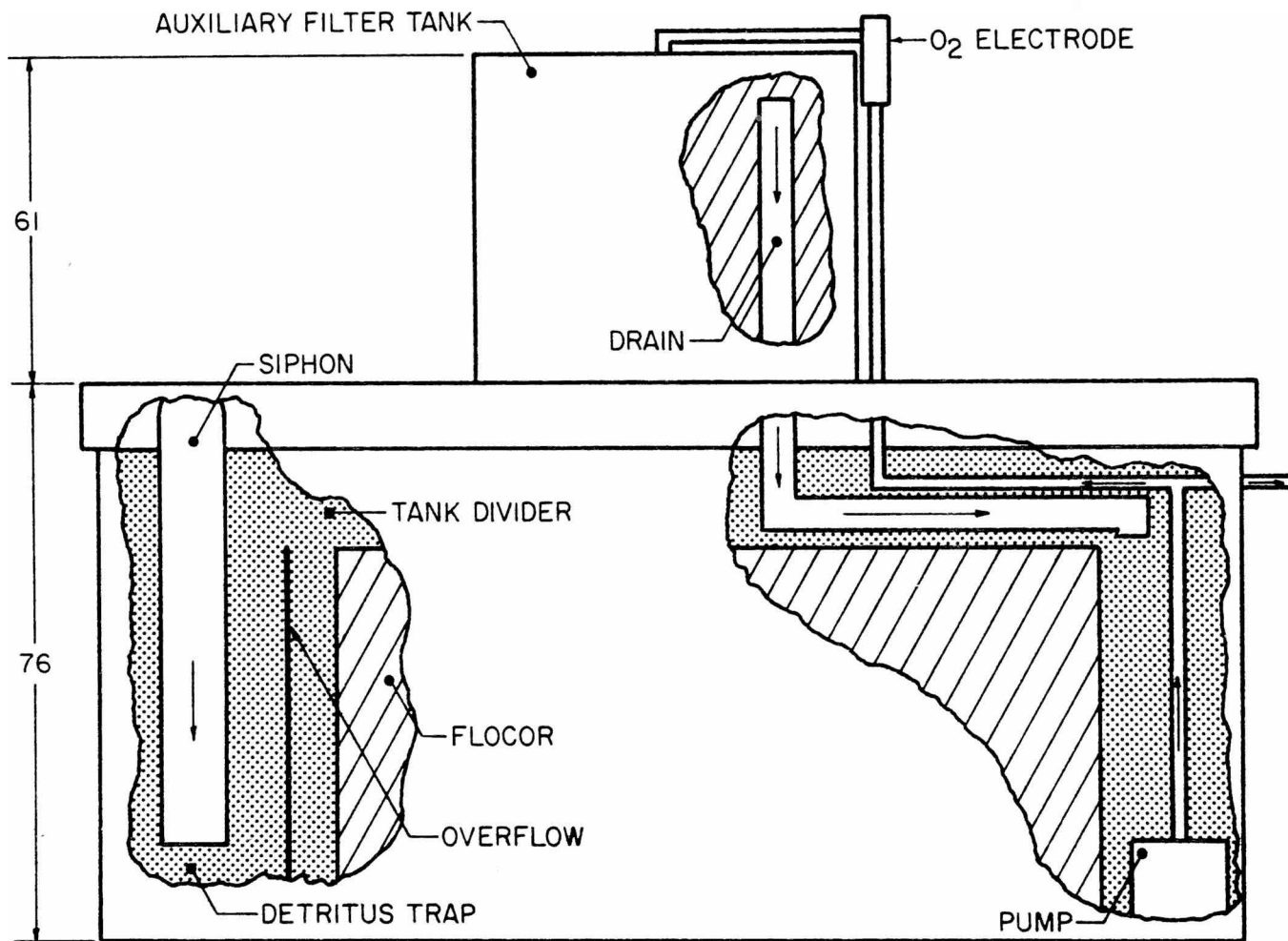

Fig. 3. View of the main-filter side of the closed system. All dimensions are in centimeters.

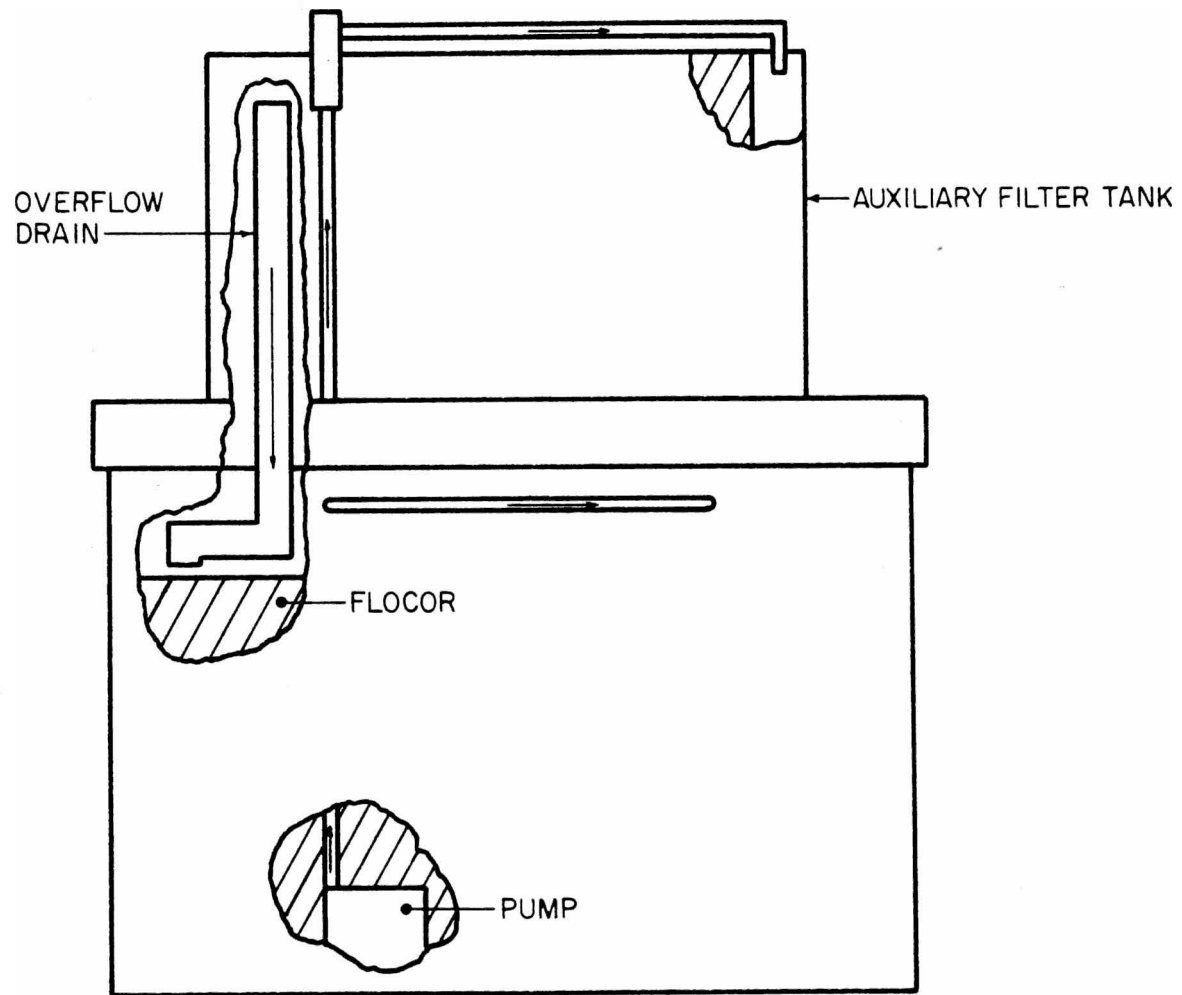

Fig. 4. View of the pump end of the closed system.

positioned in the outlet pipe of the pump and was connected to a metering system in the air-inlet valve in the pipe. The metering system triggered an audible alarm when the dissolved-oxygen level dropped below a pre-set value. Because of previous experiences with pump and power failures, air was continuously injected into the cultivation tank. When the fish in the system are large, deaths may occur within an hour after power failure. Air injection extended this time by several hours. A 5-kW generator was available to supply air when power failed for an extended period.

#### B. Biological Filtration

The eight closed systems used in this project incorporated biological filters that cleansed the water by utilizing the nitrogen cycle described by Spotte.<sup>8</sup> In this cycle, naturally occurring bacteria, Nitrosomonas and Nitrobacter, converted the ammonia generated in the systems into nitrites and nitrates. It was found that the bacteria were able to keep the ammonia levels in the systems at approximately 1 mg/l.

Initial attempts to construct a filter bed with such materials as gravel and oyster shells, as described in the literature,<sup>9,10</sup> were disappointing because of rapid plugging of the materials by slime and finely divided waste products. The filter elements ultimately used in the systems were blocks of Flocor,<sup>11</sup> a polyvinyl chloride material chosen because of its large passageways and large surface area. Three blocks of Flocor,

each having dimensions of 60 cm X 60 cm X 60 cm were used in each system. Two were positioned in the main filter area, and one was placed in the auxiliary filter tank. Flocor has a volumetric void ratio of 0.97, and the area is stated to be  $29 \text{ m}^2/\text{m}^3$ . The total surface area in each closed system available for filter growth was  $75 \text{ m}^2$ , of which 86 percent was Flocor and the remaining 14 percent was wall and partition areas. Because of the large void ratio of Flocor, the total amount of water in the system was greater than it would have been if gravel had been used as a filter bed. This greater quantity of water provided a reserve of oxygen when demand was high, such as when the detritus bed was disturbed. In addition, Flocor is lightweight and was easily removed for system cleaning and sterilization.

The greatest difficulty in creating a biological filter occurred when new materials, fresh water, and clean filter elements were used in constructing a system. Under such circumstances, the ammonia-conversion process of the nitrogen cycle required up to 3 weeks to become active. During this period, it was found advisable to place a small number of catfish (in comparison with total carrying capacity) in the system and to monitor the concentration of ammonia in the water. The concentration of ammonia generally rose to 3-10 mg/l before the biological filter became established, depending upon the number of fish in the system. When the nitrogen cycle was established, the ammonia concentration decreased suddenly, dropping to approximately 0.2-0.3 mg/l within 48-72 hr. When this concentration of ammonia was attained, a larger number of catfish

was introduced into the system, and the biological filter continued to function.

When water was originally placed in the tanks, hardening chemicals (Table I) were added to approximate well water, which is customarily used by catfish farmers. These chemicals provided a buffering capacity to hold the pH at a desirable level, and they reduced the possibility of poisoning from heavy metals. Supposedly, no heavy metals were present in the water used in this project, but accidental introduction of even a small amount of metal would have been dangerous because the water in the systems was constantly recirculating and no flushing action took place. The amounts of each chemical shown in Table I should produce a water hardness of approximately 150 grains when introduced into the volume of water contained in one of the recirculating systems.

TABLE I

## Hardening Chemicals.

Chemical	Amount (g)
$\text{NaCO}_3$	511
$\text{CaSO}_4$	260
$\text{MgSO}_4$	306
KCl	20

Once the ammonia-conversion cycle had been initiated, the catfish could be removed and the systems left empty for approximately 2 weeks without harming the ability of the filters to return to full operation when catfish were re-introduced into the systems. When any of the systems was devoid of fish for more than 2 weeks, it was considered advisable to add ammonium hydroxide to the water every few days to prevent the biological filter from dying. The ammonium hydroxide supplied the ammonia needed in the life cycle of the bacteria.

It was found that a decrease of the concentration of dissolved oxygen to a low level would cause the system to fail catastrophically, sometimes within only 24 hr. The decrease in the dissolved-oxygen concentration would cause stressed fish to begin dying. These deaths would produce a very high biological oxygen demand, further decreasing the concentration of dissolved oxygen. At this point, the rate of ammonia conversion by the aerobic bacterial filter would slow. The severely reduced dissolved-oxygen concentration and the increase of the ammonia concentration would accelerate the rate of fish mortality, and the system would collapse.

### III. EXPERIMENTAL EQUIPMENT AND PROCEDURES

Activated-charcoal filters were installed on four of the closed systems based on the hypothesis that, if growth-inhibiting factors were created by the catfish, the charcoal possibly could trap these contaminants. The granulated charcoal of these filters was contained in tubes 10 cm in diameter and 60 cm long. These filters improved the color of the water and reduced turbidity. However, the filters were subject to persistent plugging; and the flow through one of the filters would decrease to a trickle within 48-72 hr of operation. Backwashing was attempted, but was ineffective. It was felt that any part of the system that required excessive maintenance would not be effective in a catfish-rearing operation. In addition, the cost of replacement charcoal was considered to be excessive. These filters were removed after 4 months.

The temperature of the water in the systems was maintained at 25°C, mainly by the heat produced by the motors of the submersible pumps in the main filter areas. Fine control of water temperature in the systems was accomplished by varying the air temperature in the laboratory.

Throughout this project, ammonia, nitrite, and nitrate were measured using the Hach colorimetric system. Ammonia and nitrite

were measured every other day, or daily if readings justified closer checks. Nitrate was measured weekly.

The pH of the water also was measured weekly, and sodium carbonate was added if the pH decreased below 7.5. Generally, pH readings ranged from 7.5 to 8.1. Lower pH readings would have been desirable for reducing the amount of un-ionized ammonia; however, optimal operation of the biological filters required that the water be basic. Figure 5 is a graph showing filter operation versus the percentage of un-ionized ammonia. In the figure, this plot is superimposed on plots of the filter conversion efficiency as given by Meyerhof<sup>12</sup> and Engel and Alexander.<sup>13</sup> The graph shows that the requirement of low pH values to reduce the amount of un-ionized ammonia is incompatible with the pH values required for optimal conversion of ammonia by the filter. In other words, if the pH goes to low values, the filter slows down, producing large increases in the levels of both ammonia and nitrite. An increased nitrite level is particularly harmful. On the other hand, if the pH goes too high, un-ionized ammonia increases, and again poisoning can occur. An attempt to keep the total ammonia concentration low by using large volumes of water and large filters increases capital costs. It follows that precise pH control is needed, requiring expense and good maintenance. Limestone has been suggested and is used for pH control. However, at the system-loading levels required to justify the overall investment in a closed system, deposition of silt quickly covers all active sites available for dissolving the limestone and pH control is lost.



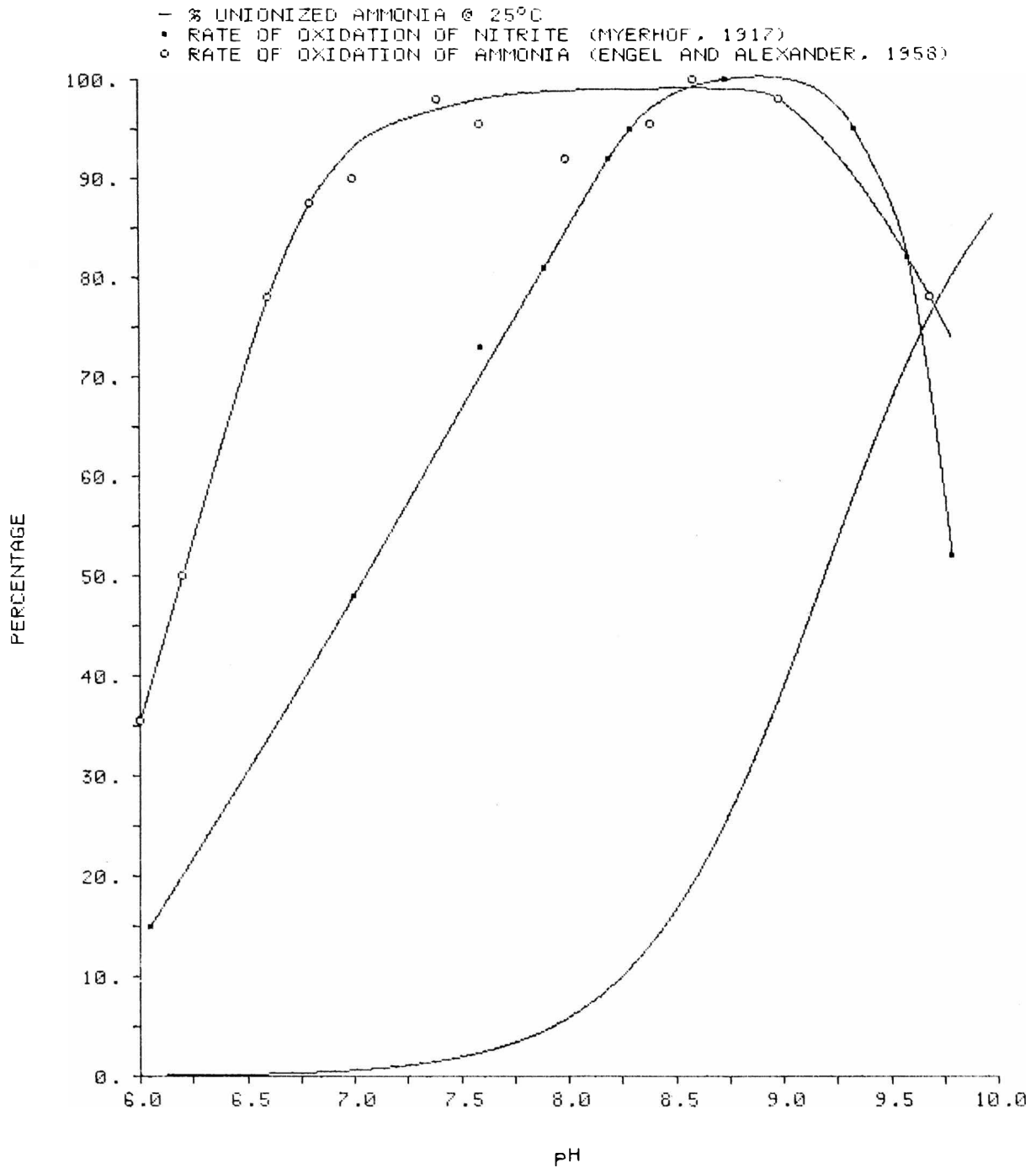

Fig. 5. Concentration of un-ionized ammonia compared with the rate of ammonia and nitrite reduction.

The weight of the catfish in the systems was determined at intervals of 30 to 60 days. Only one-third to one-half of the catfish in each system was weighed at the end of each interval, and the total weight was extrapolated from the measured values. It would have been desirable to weigh all of the catfish; however, the stress that would have been induced by handling, particularly by capturing, the fish was undesirable and, therefore, was avoided.

The fish were fed a daily ration of trout chow at 3 percent of body weight during the initial 120-day growing period. Total ammonia levels ranged from 0.1 to 1 mg/l during this period. After the initial growing period attempts to continue feeding at 3 percent of body weight resulted in rising values of the total ammonia concentration. System loading at 120 days varied from 31 to 46 kg/m<sup>3</sup> based on the volume of the living area (684 l). For the total system, including water in the filter, loading varied from 14 to 21 kg/m<sup>3</sup>.

After 120 days, a maintenance diet was instituted, with the fish being fed amounts that resulted in total ammonia levels at or below 2 mg/l. The fish were held for an additional 360 days while tests were conducted to determine if evidence of crowding factors could be detected. At the end of this period, the fish were removed, counted, and weighed. Total fish weight per system had increased by approximately 40 percent; while the number of fish per system had decreased to about half. Similar losses have been described by Rose.<sup>14</sup> The majority of the losses appeared to have been caused by cannibalism. Careful records had been compiled for

disease losses, which were small. It is possible, however, that additional disease losses occurred and the remaining fish consumed the carcasses.

To isolate any contaminants that might inhibit growth, an extraction procedure was performed by pumping water periodically from the systems that had been occupied by fish under crowded conditions for extended periods. The extractor consisted of a glass tube 2.5 cm in diameter and 122 cm long. The tube had a side arm about 15 cm from the top. The water from the system was pumped into the extractor through an orifice at the bottom. The water then bubbled through a layer of solvent 15 cm deep, then filled the tube until it ran out the side arm. As the water entered the bottom of the tube and rose, the solvent bubbled and rose with the water, the water being lighter. The solvent bubbles agglomerated and settled back to the bottom of the extractor. The flow rate of the water was adjusted to 8 l/hr, which permitted thorough mixing of the water and the solvent. The extraction process continued for 24 hr, and about 200 l of water were passed through the extractor. At the end of the extraction period, the solvent and sample were removed from the extractor. The solvent was evaporated in a rotating vacuum extractor, and the remaining sample was washed out of the extractor with a small amount of solvent and preserved until tests on specimen fish could be run. Meanwhile, the closed system from which the water had been pumped was refilled with clean water.

Heartbeat-rate measurements were made by attaching small (#18) gold-plated trout hooks to specimen catfish as shown in

Figure 6 to serve as electrodes. The electrodes were connected by shielded wire to the amplifier-filter system (Figure 7). The amplifier was a Model AD521 instrumentation amplifier made by Analog Devices. This amplifier has a high common-mode rejection ratio that helps to reduce the effects of stray pickup. The gain of the amplifier is programmed by an external resistor and was set at X40. The amplifier was followed by a Model UAF25 active filter (Figure 8) made by Burr-Brown. This filter was connected in a manner that provided a bandpass characteristic with adjustable center frequency and variable bandwidth. At the same time, the filter also provided gain. The resistors  $R_7$  and  $R_8$  shown in Figure 8 allowed adjustment of the center frequency to the signal of interest. The resistor  $R_Q$  served as the Q adjust for setting the bandwidth, which was adjusted to allow passage of the desired signal and its changes as the catfish were exposed to the extract. At the same time, opercular signals were rejected because they differed appreciably in frequency from the heartbeat rate. Good discrimination was relatively easy to achieve. The total gain of the system was approximately 1000. The Gould strip-chart recorder was used at a 1-V full-scale setting that allowed easy reading of the traces produced.

To make the heartbeat-rate measurements, one fresh, pond-raised specimen catfish was placed in a small glass tank (1 l) and was restrained by a Plexiglas frame to prevent dislodging the hooks (electrodes). Air was bubbled into the water in the glass tank in a manner that did not disturb the fish. Tests were made to determine the amount of time required for the heartbeat rate to

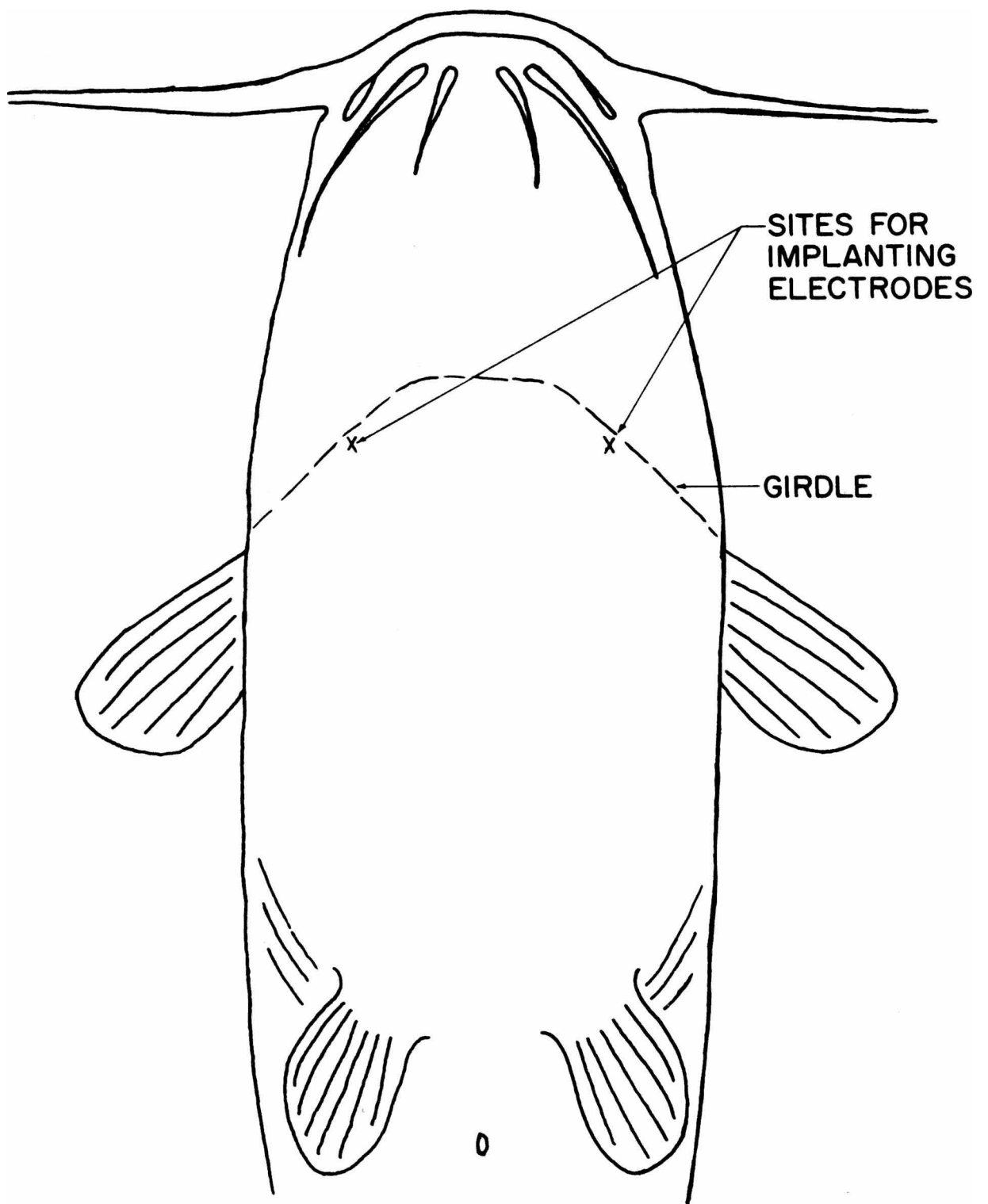

Fig. 6. Location of hooks used as electrodes at pectoral girdle of catfish.

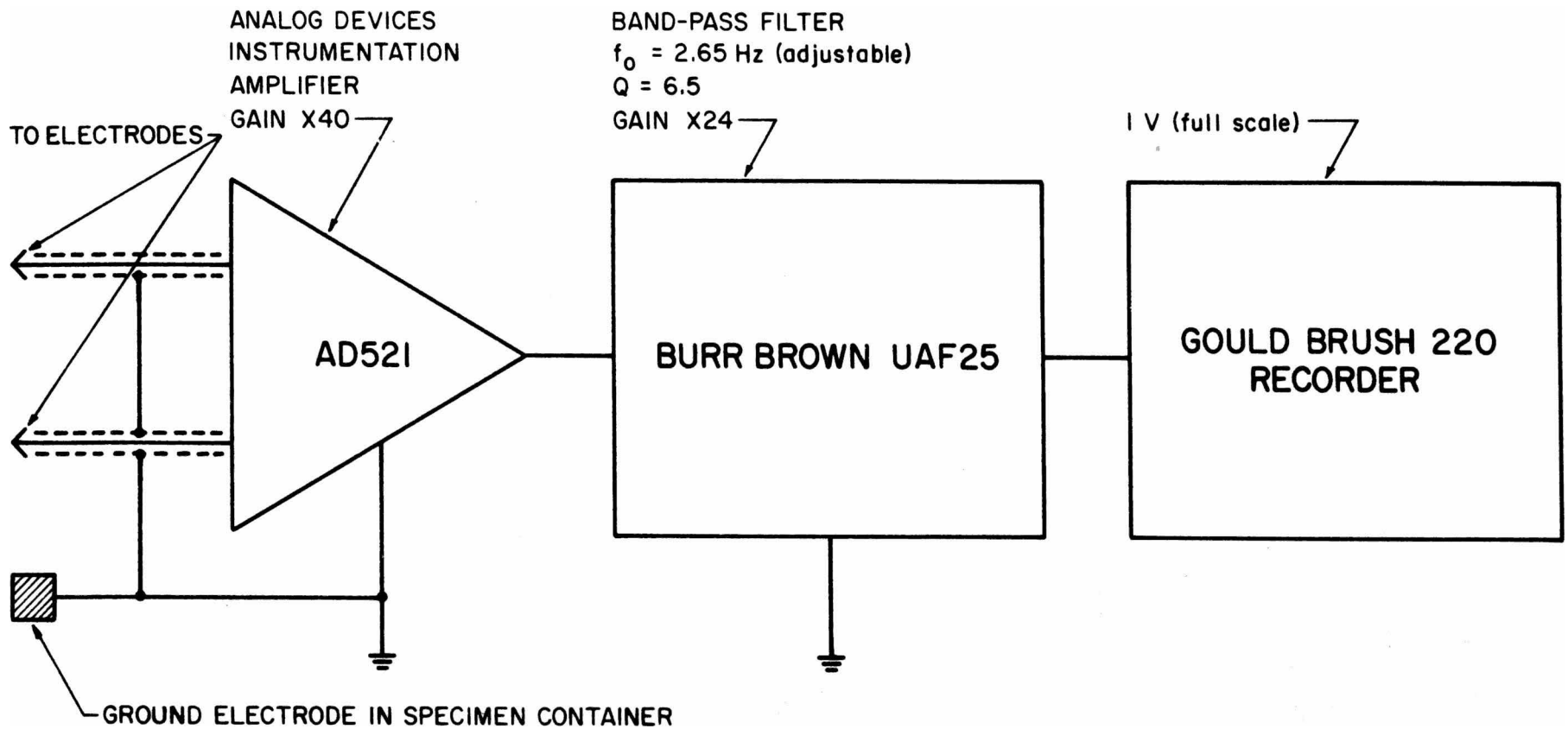

Fig. 7. Block diagram of the electronic system for amplifying, filtering, and recording the heartbeat rate.

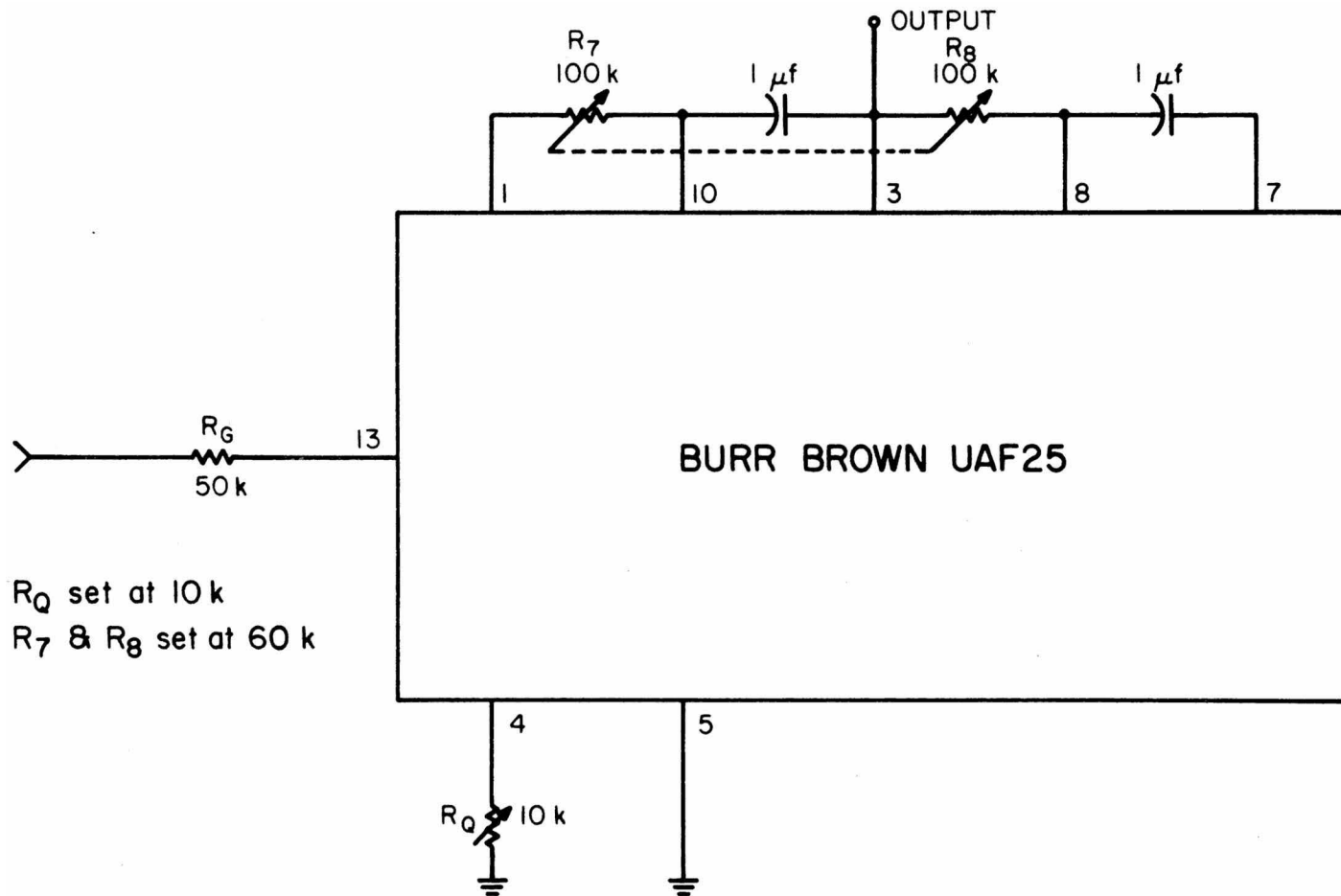

Fig. 8. Schematic diagram of the active filter.

reach equilibrium after the fish was placed in the tank. In all cases, equilibrium was reached in 2.5 min or less. The samples extracted from the solvent were dissolved in chloroform and were injected into the small tank through a lightproof metal cover 5 min after electrode attachment. The metal cover served as an electrostatic shield and also protected the specimen from being disturbed by room light and the movement of persons around the small glass tank. After 5 min, to allow for distribution of the injected sample in the water, recording of the heartbeat rate was begun. Several measurements were made at 5 min intervals to insure that the rate had stabilized and that the specimen was still viable.



#### IV. RESULTS

Tests were run using extractions made at the 120th day of system occupation and were repeated at 30-day intervals for the next 360 days. The heartbeat rate was determined by counting pulses visually from the strip-chart record 15 min after sample injection. Samples of one of the recordings are shown in Figures 9a and 9b. Results of typical tests are presented in Tables II through VII. Table VIII shows the heartbeat rate for channel catfish in a control experiment when no extract was used. The reduction in heartbeat rate was about 20 percent for most specimens. This is a significant reduction and indicates a change in the metabolic function. The change in metabolism would account for the reduced growth rate that has been observed when fish are grown in continuously recycled water. The reduction of the heartbeat rate was not significantly different for samples taken at the beginning of the 360-day period or later, indicating that saturation of the effect was reached before the 120th day of residence.

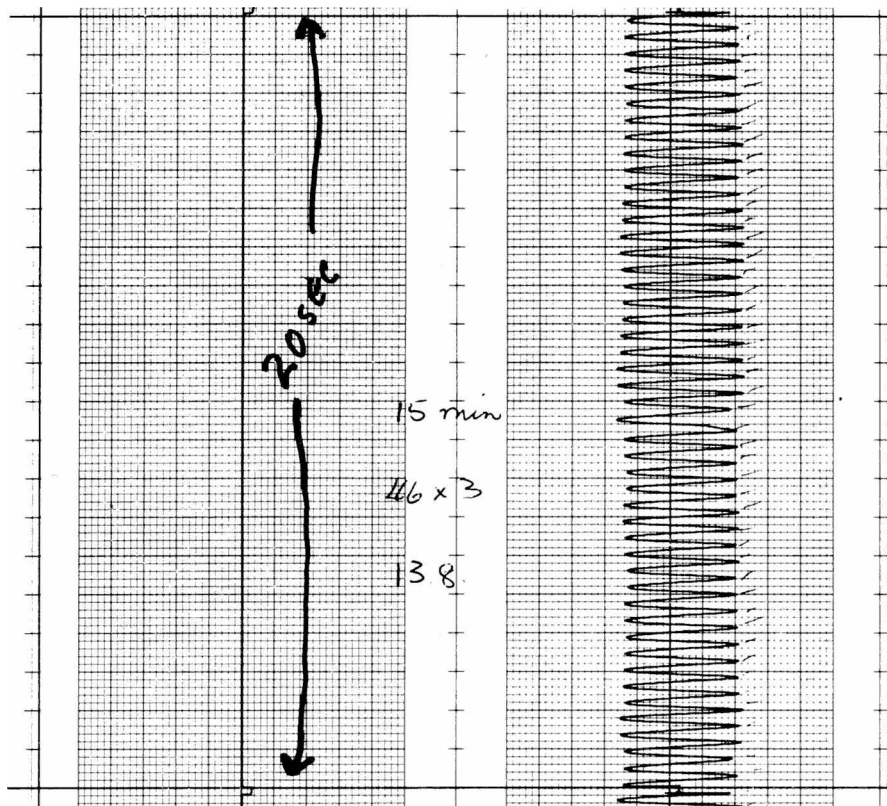

Fig. 9a. Heartbeat rate with recorder tuned to remove the opercular rate.

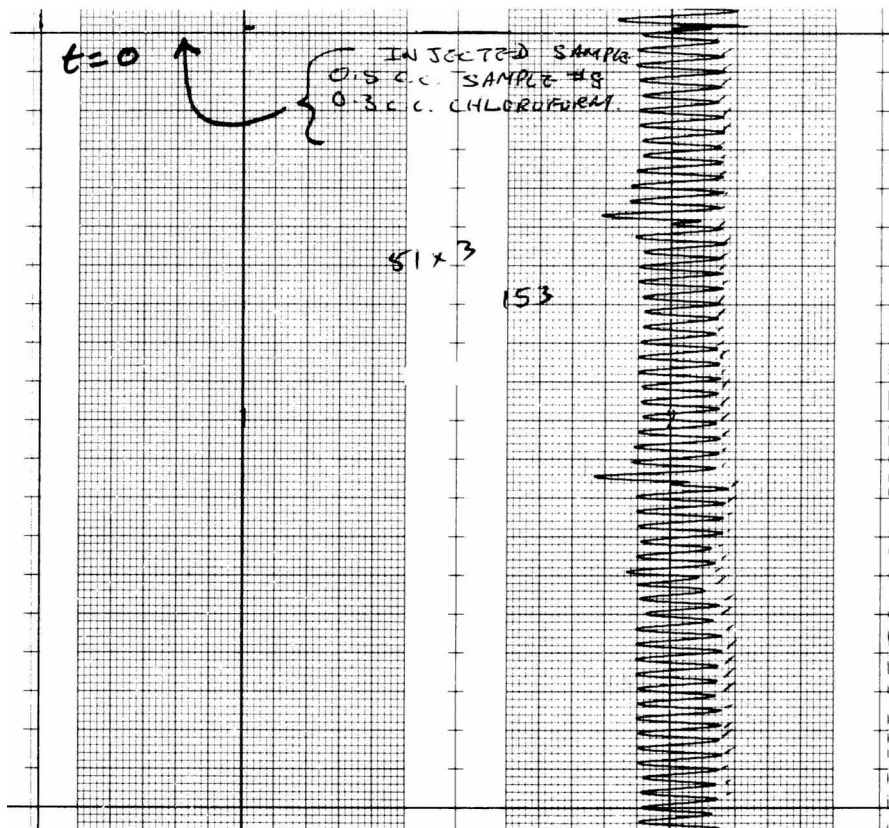

Fig. 9b. Heartbeat rate per minute with the opercular rate visible.

TABLE II  
 Effect on Heart Rate of Channel Catfish Produced by  
 Exposure to Extract No. 1 Taken From Tank No. 2  
 on April 27, 1977.

Fish Length (cm)	Sample		Heart Rate (beats/min)		Heart Rate Reduction (beats/min)
	Extract (cc)	Chloroform (cc)	Before Exposure	20 min After	
15	0.5	0.3	111	78	33
13	0.5	0.3	114	90	24
17	0.5	0.3	117	96	21
18	0.6	0.4	108	71	37
14	0.5	0.3	135	108	27
15	0.5	0.3	132	108	24
14	0.5	0.3	138	117	21
18	0.6	0.3	96	78	18
18	0.6	0.3	108	-- <sup>a</sup>	-- <sup>a</sup>

<sup>a</sup>Died after 5 min.

TABLE III

Effect on Heart Rate of Channel Catfish Produced by  
Exposure to Extract No. 2 Taken From Tank No. 5  
on April 27, 1977.

Fish Length (cm)	Sample		Heart Rate (beats/min)		Heart Rate Reduction (beats/min)
	Extract (cc)	Chloroform (cc)	Before Exposure	20 min After	
13	0.4	0.2	117	114	3
16	0.5	0.3	119	119	0
11	0.4	0.4	135	111	24
10	0.4	0.4	144	126	18
11	0.4	0.4	144	98	46
10	0.4	0.4	132	108	24

TABLE VI

Effect on Heart Rate of Channel Catfish Produced by  
Exposure to Extract No. 3 Taken From Tank No. 8  
on April 27, 1977.

Fish Length (cm)	Sample		Heart Rate (beats/min)		Heart Rate Reduction (beats/min)
	Extract (cc)	Chloroform (cc)	Before Exposure	20 min After	
14	0.3	--	135	111	24
13	0.3	0.3	160	134	26
13	0.3	0.3	140	124	16
14	0.3	0.1	144	111	33
14	0.4	0.1	108	96	12
10	0.4	0.1	142	135	7
14	0.4	0.4	144	114	30

TABLE V

Effect on Heart Rate of Channel Catfish Produced by  
Exposure to Extract No. 4 Taken From Tank No. 1  
on June 27, 1977.

Fish Length (cm)	Amount of Extract Diluted with Chloroform (cc)	Heart Rate (beats/min)		Heart Rate Reduction (beats/min)
		Before Exposure	20 min After	
15	0.8	120	90	30
14	0.6	112	96	16
13	0.6	147	117	30
11	0.6	129	126	3
11	0.6	147	132	15
13	1.0	141	114	27
14	1.0	135	114	21
17	1.0	150	75	75

TABLE VI

Effect on Heart Rate of Channel Catfish Produced by  
Exposure to Extract No. 5 Taken From Tank No. 6 on June 27, 1977.<sup>a</sup>

Fish Length (cm)	Amount of Extract Diluted with Chloroform (cc)	Heart Rate (beats/min)		Heart Rate Reduction (beats/min) <sup>b</sup>
		Before Exposure	20 min After	
13	1.0	120	126	(6)
13	1.0	141	156	(15)
14	1.0	162	162	0
13	1.0	153	144	9
14	1.0	153	156	(3)
11	1.0	165	-- <sup>c</sup>	-- <sup>c</sup>

<sup>a</sup>Because of accidental disturbance of the detritus bed in this tank, the water had been changed and flushed a week before this extraction was performed.

<sup>b</sup>Numbers in parentheses indicate increase in heart rate.

<sup>c</sup>Died before end of exposure period.

TABLE VII

Effect on Heart Rate of Channel Catfish Produced by  
Exposure to Extract No. 6 Taken From Tank No. 8  
on June 27, 1977.

Fish Length (cm)	Sample		Heart Rate (beats/min)		Heart Rate Reduction (beats/min)
	Extract (cc)	Chloroform (cc)	Before Exposure	20 min After	
17	0.5	0.3	150	123	27
18	0.5	0.3	153	126	27
13	0.5	0.3	114	74	40
15	0.5	0.3	135	111	24
13	0.5	0.3	129	111	18





## V. CONCLUSIONS

The samples extracted from the water of closed cultivation systems in which catfish had resided in crowded conditions consistently caused a reduction in the heartbeat rate of fresh specimen catfish that were exposed to the extractions. For the majority of samples, the reduction in heartbeat rate was approximately 20 percent. The effect on heartbeat rate was not significantly larger for increased amounts of extracted sample. The signal-conditioning system and particularly the tuneable active filter allowed good discrimination between the desired heartbeat signals and interference from noise and opercular signals. After total system loading reached a certain point, usually 120 days after initial stocking, increased ammonia levels required reduction of the feeding rate; consequently, the rate of weight gain was reduced to a low level. At the same time, underfeeding resulted in a large increase in cannibalism.

The following observations are made after five years of raising catfish in water-recirculating systems. An attempt to raise broilers or pigs in a sealed building with the air being purified and recirculated would be a very difficult task. Removal of large amounts of carbon dioxide would be necessary, and the system would have to recover the oxygen from the carbon dioxide.

One way of doing this would be to use living plants to perform the conversion. However, if the plants died, the system would fail.

The nitrogen cycle in closed-system culture of catfish is delicately balanced, and failure of this cycle is catastrophic to the catfish. The success of the closed system depends upon keeping two sets of living organisms in continuous good health. The catfish population must not only be kept healthy, but there must also be a thriving bacterial population. Both of these populations are subject to many threats to viability. In addition, mechanical failures are a constant threat, and backup systems to supply oxygen are needed to protect the money involved in the crop of catfish. This requirement increases capital costs.

Constant observation of the fish and filter and frequent measurement of ammonia, pH, and nitrite are needed for closed-system culture of catfish. These requirements lead to high labor costs because observation and measurement require backgrounds in biology and chemistry. An attempt to automate would result in excessive capital costs and much instrument maintenance.

Another problem lies in energy costs that result from the requirement that the water in the system must be recirculated. Low flow rates would suffice to recirculate the water if only filter requirements were considered. However, any practical system requires some sort of scouring action to remove detritus from the fish cultivation area; consequently, high flow rates, which increase energy costs, are needed.

The spread of disease in closely confined quarters is another problem; whereas in pond culture, the aquaculturist is aided by

what might be termed the dilution factor. It is true that treatment should be easier in closed systems. However, no treatment can be used if it will adversely affect the bacteria in the filter system, so at least some treatments must be discarded. In addition, the number of approved treatment substances is extremely limited.

The preceding is written simply to point out that anyone considering raising catfish in recirculating systems faces many obstacles and would require expertise in a wide range of fields. There is a viable role for closed systems, and that role is in the laboratory, where research requires controlled conditions for examining parameters of interest and where close observation of the fish is necessary.

## REFERENCES

1. Raible, R. W., "Survival and Growth Rate of Channel Catfish as a Function of Dissolved-Oxygen Concentration," Publication No. 33, Water Resources Research Center, University of Arkansas, Fayetteville (1975).
2. Solomon, D. J., "A Review of Chemical Communication in Freshwater Fish," *J. Fish Biol.*, 11; 363 (1977).
3. Pfuderer, P., Williams, P., and Francis, A. A., "Partial Purification of the Crowding Factor from Carassius auratus and Cyprinus carpio," *J. Exp. Zool.*, 187, No. 3; 375 (1974).
4. Francis, A. A., Smith, F., and Pfuderer, P., "A Heart-Rate Bioassay for Crowding Factors in Goldfish," *Prog. Fish Cult.*, 36; 196 (October, 1974).
5. Yu, M., and Perlmutter, A., "Growth Inhibiting Factors in the Zebrafish, Brachydanio rerio, and the Blue Gourami, Trichogaster trichopterus," *Growth*, 34; 153 (1970).
6. "Aquatic Toxicology Comes of Age," *Environ. Sci. Technol.*, 12; No. 1; 23 (1978).

7. Weiss, C. M., "Use of Fish to Detect Organic Insecticides in Water," J. Water Pollut. Control Fed, 37; (1965).
8. Spotte, S., Fish and Invertebrate Culture, Wiley-Interscience, N.Y. (1970).
9. Burrows, R. E., and Combs, B. D., "Controlled Environments for Salmon Propagation," Prog. Fish Cult., 300; 123 (1968).
10. "A Study for Development of Fish Hatchery Water Treatment Systems," prepared by Kramer, Chin & Mayo, consulting engineers, Seattle, Washington for Walla Walla District, Corp. of Engineers (April, 1972).
11. Flocor, registered trademark of Ethyl Corporation, Ethyl Tower, 451 Florida, Baton Rouge, Louisiana 70801.
12. Meyerhof, O., Arch. Gesamte Physiologie Menschen Tiere, 166; 255 (1917).
13. Engle, M. S., and Alexander, M., "Growth and Autotrophic Metabolism of Nitrosomonas euopaea, J. Bacteriol., 76; 217 (1958).
14. Rose, S. M., "Failure of Survival of Slowly Growing Members of a Population," Science, 129; 1026 (1959).