

6-13-2018

# Halo - A Personal IoT Air Monitor Powered by Harvested Energy

Benjamin Lampe

Santa Clara University, [blampe@scu.edu](mailto:blampe@scu.edu)

Taylor Mau

Santa Clara University, [tmau@scu.edu](mailto:tmau@scu.edu)

Samantha Morehead

Santa Clara University, [smorehead@scu.edu](mailto:smorehead@scu.edu)

Naeem Turner-Bandele

Santa Clara University, [nturnerbandele@scu.edu](mailto:nturnerbandele@scu.edu)

Follow this and additional works at: [https://scholarcommons.scu.edu/idp\\_senior](https://scholarcommons.scu.edu/idp_senior)



Part of the [Computer Engineering Commons](#), and the [Electrical and Computer Engineering Commons](#)

---

## Recommended Citation

Lampe, Benjamin; Mau, Taylor; Morehead, Samantha; and Turner-Bandele, Naeem, "Halo - A Personal IoT Air Monitor Powered by Harvested Energy" (2018). *Interdisciplinary Design Senior Theses*. 40.

[https://scholarcommons.scu.edu/idp\\_senior/40](https://scholarcommons.scu.edu/idp_senior/40)

This Thesis is brought to you for free and open access by the Engineering Senior Theses at Scholar Commons. It has been accepted for inclusion in Interdisciplinary Design Senior Theses by an authorized administrator of Scholar Commons. For more information, please contact [rscroggin@scu.edu](mailto:rscroggin@scu.edu).

**SANTA CLARA UNIVERSITY**  
**DEPARTMENT OF COMPUTER ENGINEERING**  
**DEPARTMENT OF ELECTRICAL ENGINEERING**

Date: June 11, 2018

I HEREBY RECOMMEND THAT THE THESIS PREPARED UNDER MY SUPERVISION BY

**Benjamin Lampe**  
**Taylor Mau**  
**Samantha Morehead**  
**Naeem Turner-Bandele**

ENTITLED

**Halo - A Personal IoT Air Monitor Powered by Harvested Energy**

BE ACCEPTED IN PARTIAL FULFILLMENT OF THE REQUIREMENTS FOR THE DEGREES OF

BACHELOR OF SCIENCE IN COMPUTER SCIENCE AND ENGINEERING  
BACHELOR OF SCIENCE IN ELECTRICAL ENGINEERING



Thesis Advisor

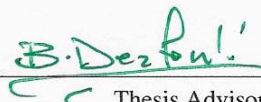

Thesis Advisor



Department Chair

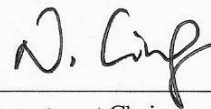

Department Chair

# **Halo - A Personal IoT Air Monitor Powered by Harvested Energy**

by

Benjamin Lampe  
Taylor Mau  
Samantha Morehead  
Naeem Turner-Bandeale

Submitted in partial fulfillment of the requirements  
for the degrees of  
Bachelor of Science in Computer Science and Engineering  
Bachelor of Science in Electrical Engineering  
School of Engineering  
Santa Clara University

Santa Clara, California  
June 13, 2018

# **Halo - A Personal IoT Air Monitor Powered by Harvested Energy**

Benjamin Lampe  
Taylor Mau  
Samantha Morehead  
Naeem Turner-Bandeale

Department of Computer Engineering  
Department of Electrical Engineering  
Santa Clara University  
June 13, 2018

## **ABSTRACT**

Urban air pollution leads to widespread respiratory illness and millions of deaths annually. PM<sub>2.5</sub>, particulate matter with a diameter less than 2.5 micrometers, is the product of many common combustion reactions and poses a particularly serious health risk. Its small size allows it to penetrate deep into the lungs and enter the bloodstream. Existing air quality monitors are aimed at scientific research, differentiating between pollutants and providing high accuracy in measurement. These devices are prohibitively expensive and cannot easily be carried around. Due to the highly localized nature of air pollution, and in order to allow individuals and institutions to easily monitor their real-time exposure to PM<sub>2.5</sub>, we propose Halo, an air quality monitor costing less than \$100. Halo is powered by a 500 mW solar panel and equipped with a 1500 mAh Lithium-Ion battery in order to handle 150 mW peak power consumption and operate continuously for over 24 hours without power input. The device is small enough to be clipped to a backpack or bag for easy portability, and it can be used in personal or public settings. Using an IR emitter and detector, Halo measures reflected IR light to determine the particulate concentration in the air with an error less than 10%. It uses Bluetooth Low Energy (BLE) to communicate these values to a user's phone. From the phone, air data can be time-stamped, stored in a cloud database, and visualized in an app for easy monitoring of pollution trends and pollution exposure. Additionally, the cloud database allows for the aggregation of data from multiple devices to create crowdsourced pollution maps. These maps can be used to pinpoint areas with particularly bad air quality in order to try to make changes to these areas or to help users to know to avoid these areas in possible.



# Table of Contents

<b>1</b>	<b>Introduction</b>	<b>1</b>
1.1	Problem Statement . . . . .	1
1.2	Benefit . . . . .	1
1.3	Architectural Diagram . . . . .	2
1.3.1	Architectural Diagram Level 1 . . . . .	2
1.4	Development Timeline . . . . .	3
<b>2</b>	<b>Requirements</b>	<b>4</b>
2.1	Background . . . . .	4
2.1.1	Current Market Air Quality Monitors . . . . .	4
2.1.2	Use Cases . . . . .	5
2.2	Functional Requirements . . . . .	6
2.3	Non-Functional Requirements . . . . .	7
<b>3</b>	<b>Design Rationale</b>	<b>8</b>
3.1	Particulates Measured . . . . .	8
3.1.1	PM2.5 . . . . .	8
3.1.2	Additional Gas Sensors . . . . .	10
3.1.3	Additional Sensors . . . . .	10
3.2	Microcontroller . . . . .	11
3.3	Energy Harvesting . . . . .	12
3.4	Power Converters . . . . .	14
3.5	Energy Storage . . . . .	15
3.6	Conclusion . . . . .	15
<b>4</b>	<b>Air Quality Monitoring Device</b>	<b>16</b>
4.1	Overview . . . . .	16
4.2	PM2.5 Sensor . . . . .	16
4.2.1	Background . . . . .	16
4.2.2	Initial Design . . . . .	17
4.2.3	Final Design . . . . .	19
4.3	Data Acquisition and Transmission . . . . .	20
4.3.1	Hardware . . . . .	20
4.3.2	Software . . . . .	21
4.4	Energy Harvester . . . . .	22
4.4.1	Background . . . . .	22
4.4.2	Initial Design . . . . .	22
4.4.3	Final Design . . . . .	23
4.5	Case . . . . .	24
4.6	Testing and Results . . . . .	27
4.6.1	PM2.5 Sensor Results . . . . .	27
4.6.2	Energy Harvester Results . . . . .	29
4.6.3	Final Cost . . . . .	30

4.7	Conclusion . . . . .	30
<b>5</b>	<b>Mobile Application</b>	<b>31</b>
5.1	Overview . . . . .	31
5.2	Requirements . . . . .	32
5.2.1	Functional Requirements . . . . .	32
5.2.2	Non-Functional Requirements . . . . .	32
5.3	State Diagram . . . . .	33
5.4	Use Cases . . . . .	34
5.4.1	Use Case 1: Connect to Microcontroller . . . . .	34
5.4.2	Use Case 2: Collect Data . . . . .	35
5.5	Results . . . . .	36
5.5.1	Mock-ups . . . . .	36
5.5.2	Prototypes . . . . .	37
5.5.3	Final Version . . . . .	39
<b>6</b>	<b>Web</b>	<b>40</b>
6.1	Overview . . . . .	40
6.2	Requirements . . . . .	40
6.2.1	Non-Functional Requirements . . . . .	41
6.3	Solution . . . . .	42
6.4	Testing . . . . .	45
<b>7</b>	<b>Social Issues Analysis</b>	<b>47</b>
7.1	Ethical . . . . .	47
7.1.1	Section I: Senior Design and Ethical Justification for project . . . . .	47
7.1.2	Section II: Senior Design Project and Virtues of Being a Good Engineer . . . . .	48
7.1.3	Section III: Senior Design Project and Safety, Risk, the Public, and Informed Consent . . . . .	49
7.2	Sustainability . . . . .	50
7.2.1	Environmental Sustainability . . . . .	50
7.2.2	Social Sustainability . . . . .	51
7.2.3	Economic sustainability . . . . .	51
<b>8</b>	<b>Future Work</b>	<b>53</b>
8.1	Condense Form Factor . . . . .	53
8.2	Integrate Additional Sensors and a Fuel Gauge . . . . .	54
8.3	Deploy Mobile Application . . . . .	54
8.4	Establish Sensor Network . . . . .	54
8.5	Machine Learning for Data Analytics . . . . .	54
<b>9</b>	<b>Lessons Learned</b>	<b>55</b>
9.1	Project Timeline . . . . .	55
9.2	Design Challenges . . . . .	55
9.3	Software and Hardware Integration . . . . .	55
9.4	Website and Mobile Application . . . . .	56
9.5	Evaluation Metrics . . . . .	56
<b>10</b>	<b>Acknowledgements</b>	<b>57</b>

# List of Figures

1.1	Architectural Diagram Level 1	2
3.1	AQI with PM2.5 Level [1]	9
4.1	Circuit With Non-inverting Op Amp	17
4.2	Data from Sensor With Poor Sensitivity	17
4.3	Circuit With Instrumentational Amplifier	18
4.4	Data from Noisy Sensor	19
4.5	Schematic for Custom Sensor	20
4.6	PCB Layout for Final Sensor Design	20
4.7	TI SimpleLink LaunchPad used for data acquisition and transmission	21
4.8	Diagram of software processes running on the embedded device	21
4.9	Schematic for Energy Harvester	23
4.10	PCB for Energy Harvester	24
4.11	Prototype Version 1	25
4.12	Mobile Application Version 2	25
4.13	Prototype Version 3 of Casing	26
4.14	Casing for the Evaluation Boards	26
4.15	Final Version of Casing	27
4.16	Sensor Performance in a Lab Setting	27
4.17	Sensor Performance at Washington Elementary School	28
4.18	Long-term Air Quality Test	29
5.1	Data Transfer Overview	31
5.2	Mobile Application State Diagram	33
5.3	Mobile Application Mock-up	36
5.4	Mobile Application Version 1	37
5.5	Mobile Application Version 2 Mock-up	38
5.6	Final Version of Mobile Application	39
6.1	Version 1 of the Website	42
6.2	Version 2 of the Website	43
6.3	Version 3 of the Website	43
6.4	Version 4 of the Website	44
6.5	Final Version of Website	44
6.6	Graph of Air Quality in SCU's Campus	45
6.7	Map of the Walk We Took	46

# List of Tables

2.1	Current Market Air Quality Monitors . . . . .	4
2.2	Initial Estimate of the Cost of One Air Quality Monitor . . . . .	7
3.1	Possible PM2.5 Sensors . . . . .	8
3.2	Additional Gas Sensors . . . . .	10
3.3	Temperature, UV, and Humidity Sensors . . . . .	10
3.4	Microcontrollers . . . . .	11
3.5	Power From Energy Harvested Sources [6] . . . . .	12
3.6	Energy Sources [7] . . . . .	13
3.7	Power Converters - IC Chips . . . . .	14
3.8	Super Capacitor Life Span [8] . . . . .	15
4.1	Energy Harvester Power Measurements . . . . .	29
4.2	Final Cost Breakdown for our Prototype . . . . .	30
5.1	Mobile Application Functional Requirements . . . . .	32
5.2	Mobile Application Non-Functional Requirements . . . . .	32
6.1	Website Functional Requirements . . . . .	40
6.2	Website Non-Functional Requirements . . . . .	41
8.1	Future Work to Be Completed . . . . .	53

# Chapter 1

## Introduction

### 1.1 Problem Statement

Air pollution can cause irreparable damage to the health of human beings and harms our environment. Worse, many people are not aware of the sources of pollution in their everyday surroundings. According to the World Health Organization, polluted air contributes to one in eight deaths worldwide and 92% of the world's population live in places where air pollution exceeds safe limits [16]. Research is also showing that 1 in 8 deaths can be associated with impacts of air pollution [17]. This is a serious problem that many people do not know about.

There are some air quality monitors on the market, but many consume significant power causing them to be larger in size and more expensive. Most monitors are not portable, so they only provide measure the air quality in one location. Finally, they are often powered by batteries, which limit the longevity of the device.

Our aim was to create a device powered by harvested energy that can monitor and log air pollution levels. This device could be used in homes and cities regardless of current infrastructure in order to bring awareness to their exposure to harmful particulates. These populations can then make decisions about improving their environment.

### 1.2 Benefit

Halo is meant to draw awareness to the issue of air quality and enable healthy decisions in both the personal and public realm. On a personal level, users can know how to plan their outdoor activities when the air quality is good, open a window while cooking if the room has become smoky, or move out of a city where the air quality is consistently bad. Governments and citizens will also have access to aggregate information that can be used to implement policies to protect the health of the community. Halo can also be useful in school, as children are more sensitive to the health effects of poor air quality. Often, inner city schools are located close to freeways, which can present serious pollution risks for the students. In this case, Halo can be stationed in the school, where it will constantly monitor, track, and display the air quality, allowing schools to take appropriate action to protect student health.

## 1.3 Architectural Diagram

We began this project by building a proof of concept that we used to compare our final product to. We started by purchasing parts such as the Sharp PM2.5 sensor, two small solar panels, an Arduino, and a lithium ion battery. We then built our own air quality sensor using IR emitters and detectors. We also tested other sources of harvesting energy such as RF and vibrations. Finally, we used a microprocessor to collect the data from our sensor and used bluetooth to send the sensor information to a phone. We also created a central database that all of the sensor information is sent to. Figure 1.1 shows the level 1 block diagram.

### 1.3.1 Architectural Diagram Level 1

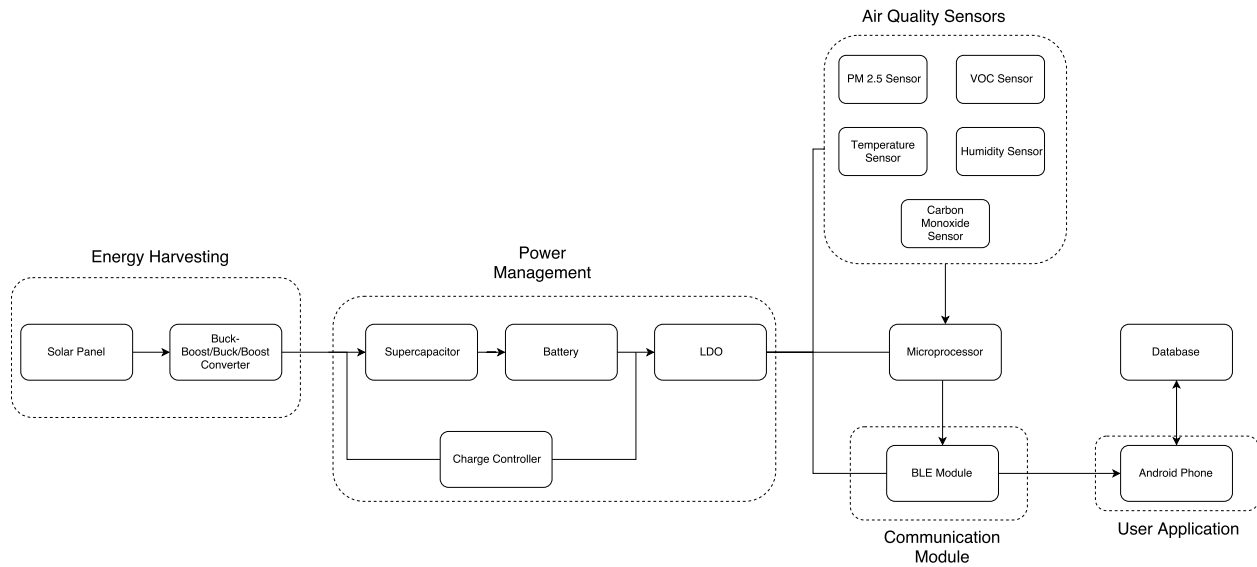
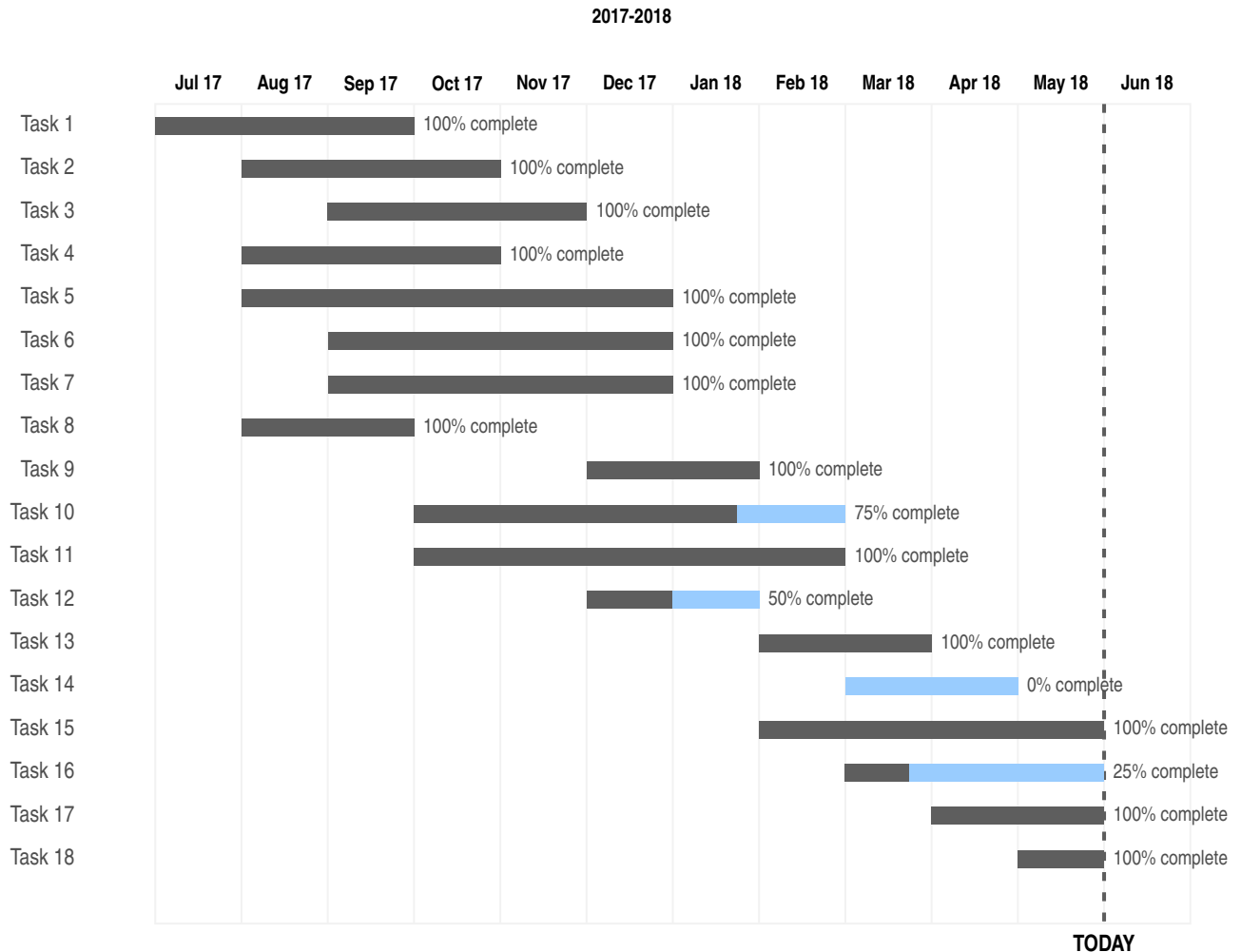

Figure 1.1: Architectural Diagram Level 1

Our block diagrams begin with energy harvesting. Energy harvesting will provide the necessary power to operate the device without it ever having to be plugged in to charge. The power from the energy source will not be constant, so power management is necessary to provide a consistent input to the rest of the device. This power will then go to various air quality sensors and a microcontroller. The air quality sensors will test for particulate matter, carbon monoxide, volatile organic compounds, temperature, and humidity. The output of these sensors will be connected to a microprocessor. The microprocessor will interpret the data and send it to a phone through a bluetooth connection. From there, an app on the phone will send the data to a central database.

## 1.4 Development Timeline

The development timeline shows both the project schedule and our current progress.



Task 1. Research Harmful Particulates and Potential Energy Sources

Task 2. Determine Particulates to Measure and Energy Sources to Use

Task 3. Determine Web, Mobile, and Cloud Database Technologies

Task 4. Complete Project Budget

Task 5. Order All Project Parts

Task 6. Assemble Prototype Solar Energy Harvester

Task 7. Design Prototype PM 2.5 Sensor

Task 8. Mock-up iOS App and Website

Task 9. Incorporate Temperature, Humidity and Other Gas Sensors

Task 10. Complete iOS App

Task 11. Finish Website

Task 12. Order PCBs for Energy Harvester and PM 2.5 Sensor

Task 13. Finalize Casing Design

Task 14. Assemble and Test Integrated Portable Energy Harvester and PM 2.5 Sensor Module

Task 15. Assemble Two to Five Additional Portable Modules

Task 16. Conduct Extensive Field Testing in Santa Clara County Schools and Community

Task 17. Prepare for Senior Design Presentation

Task 18. Present at Senior Design Conference

# Chapter 2

## Requirements

This section includes requirements for our project that we determined by looking at current market air quality monitors and seeing what was missing in the market. We found that there was no low cost device because most of the devices cost over \$200. We also found that there are almost no portable devices on the market, which limits users awareness of what they are breathing in wherever they go. Finally, we selected a few use cases that helped us to narrow the scope of our device.

### 2.1 Background

#### 2.1.1 Current Market Air Quality Monitors

Few air quality monitors exist on the market today. There are research devices that can detect many types of air pollutants with great accuracy and cost thousands of dollars. There are also some air quality monitors on the market meant for home use. That cost between \$150 and \$400. These devices are often for indoor use only. Finally, there is one new device coming out that is meant to be portable, so the user can track his/her air quality as they go about daily activities. However, this device still costs \$200, which makes it unfeasible for a wide audience.

Table 2.1 shows a list of some of the air quality monitors on the market today including their cost, what they measure, and their portability.

Table 2.1: Current Market Air Quality Monitors

	Aerotrack [2]	Uhoo[3]	Speck 2.0 [4]	Flow [5]
Cost	\$2380	\$299	\$199	\$199
Particles Measured	0.5 $\mu$ m 1.0 $\mu$ m 2.0 $\mu$ m 2.5 $\mu$ m	2.5 $\mu$ m, VOC Carbon monoxide Ozone	2.5 $\mu$ m	2.5 $\mu$ m, 10 $\mu$ m VOC Nitrogen dioxide
Portable	Yes	No	No	Yes



## **2.1.2 Use Cases**

Before we began designing a device, we needed to determine who our audience was going to be. We knew from our research that air pollution is a immense problem all around the world, and we knew that we were not going to be able to help everyone facing this issue. We decided to narrow our users to three categories, so we could begin our project. We determined these categories to be personal use, use in schools, and use by firefighters.

### **Personal**

After researching the various current market air quality monitors, we found that most of them were expensive and not portable. We determined that air quality is such a prevalent issue, there needed to be a low-cost, air quality monitor that could reach a wider audience than many of the current air quality monitors. We also wanted to create a portable device, so that users could track their exposure to air pollutants throughout the day instead of use in one room in their house. They could be exposed to high levels of air pollutants on their walk to work, in their office building, or in various other locations. A portable device would allow users to know their air quality where ever they go.

### **Schools**

Inner-city schools often experience higher levels of air pollution due to their proximity to highway and city traffic pollution. This is particularly troubling because youth are especially susceptible to developing asthma from extended exposure to air pollution. We met with Dr.Iris Stewart-Frey, from the Santa Clara University Environmental Studies department, who is doing research to measure the air quality at schools in San Jose. She expressed that a stationary air quality device that could be permanently placed in these schools would be helpful to her research.

### **Firefighters**

Finally, we met with firefighter Sean Lanthier through the Frugal Innovation Hub. He told us that firefighters experience a much higher risk of getting cancer due to their exposure to air pollutants. He also told us that firefighters actually experience the most exposure to air pollutants after the fire is out. They will take their masks off, assuming they are safe, but the air is still swarming with hazardous particles. Firefighters could use a personal air quality monitor that could alert them to when it is safe and when it is unsafe to take off their masks.

## 2.2 Functional Requirements

The functional requirements below describe the various functionality of the system and specifics on how the various components will interact with each other. We developed these requirements based on current market air quality monitors and our use cases.

- Accuracy: 10% error or less
  - Reference sensors have accuracy ratings of  $1V/100\mu g/m^3$ , so our custom should be able to reach this same level of sensitivity
  - PM2.5 is measured on a scale for 0 to  $500.4\mu g/m^3$ , so a 10% error would be acceptable within these ranges
- Power: Energy harvester should produce 500mW
  - Sharp sensor requires 496mW power, not including the fan
  - IR emitter and detector require  $\sim 200mW$
  - Bluetooth(Rx and TX) requires  $\sim 100mW$
  - 2 small solar panels can produce 500mW
- Operating Voltage:  $3.3V \pm .05$
- Dimensions:  $24in^3$
- Weight: 100g
- Power:
  - Integrated 500mAh battery
  - 24h autonomously
- Sampling Interval:
  - 1 sample/min
- Pollution Sensing:
  - VOC:volatile organic compounds
  - PM 2.5: particulate matter under 2.5 micrometers
  - Carbon Monoxide
- On Board Storage:
  - 10kB of data
  - Equivalent to 1 day
- Connectivity: BLE

## 2.3 Non-Functional Requirements

The non-functional requirements describe the overall characteristics of the system.

- Cost \$150 or Less
  - Current products on the market cost \$200 or more
  - We budgeted our module to cost \$99
- Device should be no larger than 24 cubic inches
  - Solar Panel: 1” x 3.5” x 0.2”
  - 500mAh Li-ion Battery: 1.15” x 1.4” x 0.19”
  - PVC pipe: 0.5” diameter
  - Average backpack: 16” x 14” x 5”
    - \* Our device should be able to easily clip onto a backpack
- Must be able to use incoming data to create crowdsourced pollution maps

Table 2.2: Initial Estimate of the Cost of One Air Quality Monitor

Item	Quantity	Cost	Total Cost
IR Emitter/Detector	2	\$4	\$8
Humidity sensor	1	\$2	\$2
Custom PCB	2	\$12	\$24
Energy Harvesting	1	\$50	\$50
Res/Cap/Op Amp	-	\$10	\$10
PVC pipe/Casing	1	\$5	\$5
Total			\$99

# Chapter 3

## Design Rationale

### 3.1 Particulates Measured

#### 3.1.1 PM2.5

PM2.5 stands for particulate matter less than 2.5 micrometers. These tiny particles are created in combustion reactions. They are extremely light, so they stay in the air for a long period of time. They penetrate deep into the lungs and bloodstream, which can result in disastrous health effects after long-term exposure. While some air quality monitors measure coarse particles between 2.5 and 10 micrometers, these particles are often less toxic, cannot travel as far, and cannot penetrate as deeply into the lungs. Ultimately, PM2.5 is the main cause of health issues related to air, so it is a good basis for determining air quality. [15]

We looked into possible sensors to measure PM2.5. We found that we could buy a pre-made sensor off the shelf or create our own sensor. The table below shows some of the comparisons of possible PM2.5 sensors.

Table 3.1: Possible PM2.5 Sensors

Possible Implementation	Accuracy	Operating Voltage	Power	Cost
Sharp DN7C3CA006	High	5V	805mW	\$30
Shinyei PPD42NS	Low	5V	400mW	\$15
IR Emitter and Detector	Unknown	3.3-5V	207mW	\$4

Ultimately, we decided to create our own sensor out of an IR emitter and detector because it would be less expensive and require less power. We also chose to use the Sharp sensor as a reference sensor to compare our custom sensor to.

From a PM2.5 measurement, an Air Quality Index (AQI) value can be determined. The AQI was created by the Environmental Protection Agency as a way to standardize air quality measurements in a way that is easy to understand and easily comparable. Figure 3.1 shows the official AQI and the corresponding PM2.5 level published by the EPA.

PM <sub>2.5</sub>	Air Quality Index	PM <sub>2.5</sub> Health Effects	Precautionary Actions
<b>0 to 12.0</b>	<b>Good</b> 0 to 50	Little to no risk.	None.
<b>12.1 to 35.4</b>	<b>Moderate</b> 51 to 100	Unusually sensitive individuals may experience respiratory symptoms.	Unusually sensitive people should consider reducing prolonged or heavy exertion.
<b>35.5 to 55.4</b>	<b>Unhealthy for Sensitive Groups</b> 101 to 150	Increasing likelihood of respiratory symptoms in sensitive individuals, aggravation of heart or lung disease and premature mortality in persons with cardiopulmonary disease and the elderly.	People with respiratory or heart disease, the elderly and children should limit prolonged exertion.
<b>55.5 to 150.4</b>	<b>Unhealthy</b> 151 to 200	Increased aggravation of heart or lung disease and premature mortality in persons with cardiopulmonary disease and the elderly; increased respiratory effects in general population.	People with respiratory or heart disease, the elderly and children should avoid prolonged exertion; everyone else should limit prolonged exertion.
<b>150.5 to 250.4</b>	<b>Very Unhealthy</b> 201 to 300	Significant aggravation of heart or lung disease and premature mortality in persons with cardiopulmonary disease and the elderly; significant increase in respiratory effects in general population.	People with respiratory or heart disease, the elderly and children should avoid any outdoor activity; everyone else should avoid prolonged exertion.
<b>250.5 to 500.4</b>	<b>Hazardous</b> 301 to 500	Serious aggravation of heart or lung disease and premature mortality in persons with cardiopulmonary disease and the elderly; serious risk of respiratory effects in general population.	Everyone should avoid any outdoor exertion; people with respiratory or heart disease, the elderly and children should remain indoors.

Figure 3.1: AQI with PM2.5 Level [1]

Each category is associated with a range of PM<sub>2.5</sub> values, a range of AQI value, and a word to help individuals make sense of the numbers. Colors are also used to indicate the air quality with green representing good air quality and shades of red representing dangerous air quality. Finally, the AQI provides helpful instructions to allow people to make appropriate decisions base on the AQI.

### 3.1.2 Additional Gas Sensors

PM2.5 is not the only gas that can contribute to poor air quality, so we wanted to include additional sensors that could measure other pollutants like carbon monoxide and volatile organic compounds (VOC). Table 3.2 shows possible sensors we thought about including in our device.

Table 3.2: Additional Gas Sensors

Possible Implementation	Gas Measured	Power	Cost
Parallax MQ-7	Carbon Monoxide	800mW	\$6
SPEC 110-102	Carbon Monoxide	50uW	\$20
MQ-135	VOC	800mW	\$5
CCS811	VOC	unknown	\$20

Note: VOC stands for Volatile Organic Compounds

As of now, we only include the PM2.5 sensor in our device, but will consider including these additional sensors in future implementations of our device.

### 3.1.3 Additional Sensors

We also wanted to include some additional sensors in our device. We needed a humidity detector because water particles can effect the sensitivity of our device. Water particles can reflect light in the same way that gas particles do, so when it is humid, the readings from the sensors will vary slightly. Therefore, we must include the humidity as a factor in our calculation in air quality. We also wanted to include a temperature sensor and a UV sensor to provide additional information to our users. Table 3.3 shows some sensors we thought about including.

Table 3.3: Temperature, UV, and Humidity Sensors

Possible Implementation	Measurement	Power	Cost
VEML 6070	UV Radiation	0.5 mW	\$2.39
HIH-5030	Humidity	1 mW	\$11.47
TI LMT70	Temperature	45 $\mu$ W	\$1.86
SI7021	Temp and Humidity	300 $\mu$ W	\$6.95

Ultimately we decided to use the Si7021 because of it was low power, inexpensive, and easy to use.

## 3.2 Microcontroller

In order to control the sensors and report their output, we looked at several microcontroller options. Because this was a small device and we wanted to power it from harvested energy, power consumption was one of our main selection criteria. Additionally, we wanted a controller with a high-resolution analog-to-digital converter (ADC), so that we could accurately sample our analog sensors. Finally, in order to send sensor information to a mobile device, we needed a communication method with the board.

We looked at several wireless communication methods including WiFi, Bluetooth, and Zigbee, but we ultimately settled on Bluetooth Low Energy (BLE), due to its low power consumption, ease of implementation, and the prevalence of Bluetooth as a built-in feature for mobile phones. Table 3.4 lists out the options we considered.

Table 3.4: Microcontrollers

Controller	Power Consumption	ADC	Communication
ATMega328	360 $\mu$ W	8 bits	None
CC2640R2F	109 $\mu$ W	12 bits	BLE
Artik 020	113 $\mu$ W	12 bits	BLE
ATSAMB11	288 $\mu$ W	11 bits	BLE

After considering all of these criteria, we selected a TI CC2640R2F as our controller. We selected the TI controller for its low power consumption, incorporation of BLE, high-accuracy ADC, and the wealth of design resources available through TI's online help forum.

### 3.3 Energy Harvesting

Given that the intent of Halo project was to develop a network of wireless air quality sensors, we determined that energy harvesting would be beneficial. Wireless sensor networks (WSN) have seen increased interest and use over the last several years with the rise of the Internet of Things (IoT). An interconnected network of closely packed sensor nodes is powerful. When aggregated together, wireless sensor nodes can be used for environmental monitoring, hazard detection, structural monitoring, and city management. WSNs can have a variety of design constraints, such as sensing methods, data transfer and storage, component costs, communications, and applications. Each of these constraints requires energy.

Traditionally, individual sensor nodes have been powered solely by batteries. However, one major weakness of existing sensor network nodes is that they are limited by the finite nature of batteries. Upon depletion of the battery capacity, sensor networks must have their batteries replaced which decreases the effectiveness of a WSN. A variety of computational methods exist to maximize the lifetime of battery-powered WSNs such as duty cycling strategies, resource allocation management, and adaptive sensing, to name a few. However, these methods are restricted by the inherent nature of batteries. Recent work has focused on maximizing the lifetime of WSNs through energy harvesting. Energy harvesting, in theory, can be used to perpetually sustain sensor nodes by continuously using energy from the surrounding environment.

Energy harvesting consists primarily of three basic components:

- The energy source
- The harvesting architecture
  - Harvest-use
  - Harvest-store-use
- The load

The following tables show energy sources that we explored using for our device.

Table 3.5: Power From Energy Harvested Sources [6]

Source	Source Power	Harvested Power
<b>Light</b>		
Indoor	0.1 mW/cm <sup>2</sup>	10 μW/cm <sup>2</sup>
Outdoor	100 mW/cm <sup>2</sup>	10 mW/cm <sup>2</sup>
<b>Vibration/Motion</b>		
Human	0.5m at 1 Hz	
	1m/s <sup>2</sup> at 50 Hz	4 μW/cm <sup>2</sup>
Machine	1m at 5 Hz	
	10m/s <sup>2</sup> at 1 kHz	100 μW/cm <sup>2</sup>
<b>Thermal</b>		
Human	20 mW/cm <sup>2</sup>	30 μW/cm <sup>2</sup>
Machine	100 mW/cm <sup>2</sup>	1-10 mW/cm <sup>2</sup>
<b>RF</b>		
GSM BSS	0.3 μW/cm <sup>2</sup>	0.1 μW/cm <sup>2</sup>



Table 3.5 highlights the power that can be obtained from common energy harvesting sources. The power that can be harvested from outdoor light is substantially more than other sources.

Table 3.6 illustrates the characteristics of energy harvesting sources.

Table 3.6: Energy Sources [7]

<b>Energy Source</b>	<b>Characteristics</b>
Solar	Ambient, Uncontrollable, Predictable
Wind	Ambient, Uncontrollable, Predictable
RF Energy	Ambient, Partially controllable
Body heat, Exhalation, Breathing and Blood Pressure	Passive human power, Uncontrollable, Unpredictable
Finger motion and Footfalls	Active human power, Fully controllable
Vibrations in indoor environments	Ambient, Uncontrollable, Unpredictable

If an energy source is ambient this means that it can come from the surrounding environment. If an energy source is controllable, then it does not require predicting or scheduling. Ultimately we decided to use solar energy as it produced the most power, was predictable, and was the least expensive.

### 3.4 Power Converters

The output coming from an energy source is often unregulated. We needed to be able to provide our sensors and microcontroller with a consistent 3.3V, so we utilized a power converter as a bridge between our load and our energy harvester. By using a power converter, we were able to maximize the energy output. We researched various power converters for our air quality monitor to ensure we chose a suitable converter. The table shows various power converters that we looked into. We selected the TI BQ25505 for our final design given that it allowed for dual energy storage and input voltage regulation.

Table 3.7: Power Converters - IC Chips

Possible Implementation	Type	Features	Cost
TI BQ25505	Boost	Charge controller, MPPT, Cold-Start unit, Dual energy storage	\$5.63
MAX17710	Boost	LDO, Charge controller, Multi-input harvesting	\$7.67
MAX77650	Buck-Boost	Charge controller, LDO, Cold-Start unit	\$4.73
LTC3330	Buck-Boost	LDO	\$5.07
SPV1050	Buck-Boost	LDO, MPPT, Charge controller	\$3.14

### 3.5 Energy Storage

For our energy storage, we chose to use both a supercapacitor and a battery. By using a battery and a super capacitor, we increase the life of the battery.

- Supercapacitor functions as a secondary energy storage source when the battery is exhausted
- Supercapacitor life cycle is longer than batteries
- Supercapacitor used as a buffer for battery to decrease charge and discharge

Table 3.8 shows that the battery life at 25°C is 13.356 yrs ( $117000/24/365 = 13.356$  yrs).

Table 3.8: Super Capacitor Life Span [8]

<b>Datasheet end of life</b>	<b><i>Voltage across the supercapacitor</i></b>	
	2.7 V	2.5 V
<b><i>Chamber temperature:</i></b>	<b><i>End of life: <sup>b</sup></i></b>	
$\theta = 65^{\circ}\text{C}$	3670 h	7330 h
$\theta = 55^{\circ}\text{C}$	7330 h	14700 h
$\theta = 45^{\circ}\text{C}$	14700 h	29300 h
$\theta = 35^{\circ}\text{C}$	2930 h	58700 h
$\theta = 25^{\circ}\text{C}$	58700 h	117000 h

<sup>b</sup>. End of life  $\Leftrightarrow$  20% reduction of the rated capacitance

### 3.6 Conclusion

In sum, all elements of the project were picked based on existing research and design requirements. PM2.5 was selected as the primary particulate to measure given that it is the principle cause of health issues related to air pollution. Additional gas sensors were evaluated but not incorporated in this implementation of the design. A humidity sensor was added to obtain more accurate air quality readings. A BLE-enabled microcontroller was selected due to its low power consumption and the ubiquity of bluetooth. Finally, a solar energy harvester was chosen due to the high amount of power that can be obtained from light as opposed to alternate energy sources. The next chapter details our implementation utilizing the aforementioned design criteria.

## Chapter 4

# Air Quality Monitoring Device

### 4.1 Overview

The purpose of the air quality sensor is to detect the quality of air. First, a PM2.5 sensor is used to measure the users air quality and output a voltage reading that correlates to air quality. This voltage is read by a microcontroller, which converts the voltage reading from the sensor to an AQI value. Finally, the microcontroller sends the AQI value to the mobile app using a BLE connection. Energy harvesting is used to power both the microcontroller and the PM2.5 Sensor. Finally, all these devices are included in a single case, so the user can easily take the device on the go with them.

### 4.2 PM2.5 Sensor

#### 4.2.1 Background

As mentioned in section 3.1.1., we determined that measuring PM2.5 would give us the best indication of our user's air quality. It is also one of the easiest ways to measure air quality because other hazardous pollutants like VOC and carbon monoxide can only be detected through a chemical reaction. We also decided that we wanted to build our own PM 2.5 sensor. We found that other sensors on the market were either expensive or inaccurate and required a lot of power (see Table 3.1), which would not have worked in our application.

After looking at several reference designs and on the market solutions, we first determined that we needed to us an optical solution for our custom sensor. An optical solution uses an IR emitter and detector pairing to detect the gas particles in the air. Both the IR emitter and detector must be placed in a dark enclosure. The IR detector should be placed outside of the range of the IR emitter, so that the only light the detector sees is the light reflected by gas particles. The amount of light detected by the IR detector correlates to the amount of gas particles in the air.

We specifically chose an IR emitter and detector pairing at a wavelength of 940nm. We did this because water is reflected at wavelengths less then 3nm, from 5-8nm and above 16nm [14]. We wanted to be outside these ranges to ensure that we were mostly detecting gas rather than water particles.

Finally, for our IR detector, we chose to use a phototransistor as opposed to a photoresistor or a photodiode. Phototransistors are the most sensitive and highest output reading, which was important to detecting the small changes we needed to detect.

## 4.2.2 Initial Design

The change in output between clean air and smoky air with a phototransistor was fairly small and noisy. We determined we needed to amplify and filter the output. We first began by converting the current in the phototransistor to a voltage using a resistor. We then amplified this voltage using a non-inverting amplifier and added a low pass filter at the output. Figure 4.1 shows the schematic for this circuit.

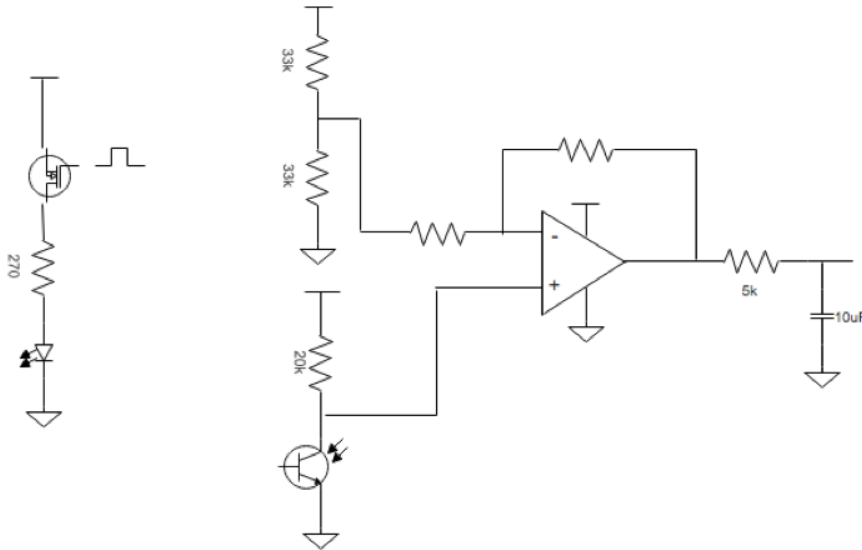

Figure 4.1: Circuit With Non-inverting Op Amp

We found this circuit to be very noisy, and it did not have the sensitivity we were hoping to see. Figure 4.2 shows the poor performance of this circuit. We placed the sensor in a clean environment and then introduced smoke. We only saw a 50mV from clean to smoky air, which not be enough for us to detect fine levels of change.

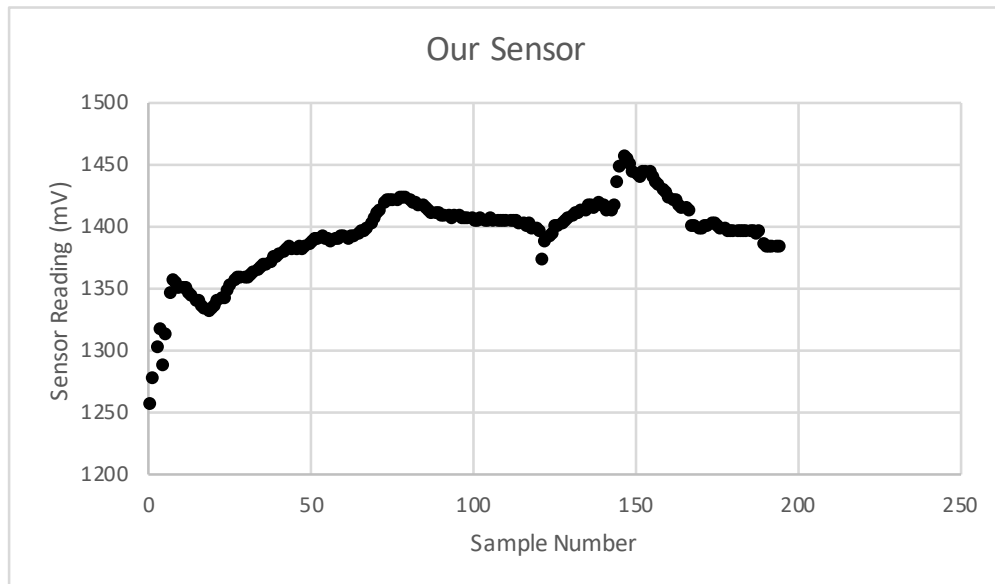

Figure 4.2: Data from Sensor With Poor Sensitivity

We then experimented with an instrumentational amplifier. We thought this would increase our sensitivity because we would be able to amplify between a range of 0V to 3.3V rather than 1.65V to 3.3V amplification range we used in the previous example. Figure 4.3 shows the schematic we created with an instrumentational amplifier.

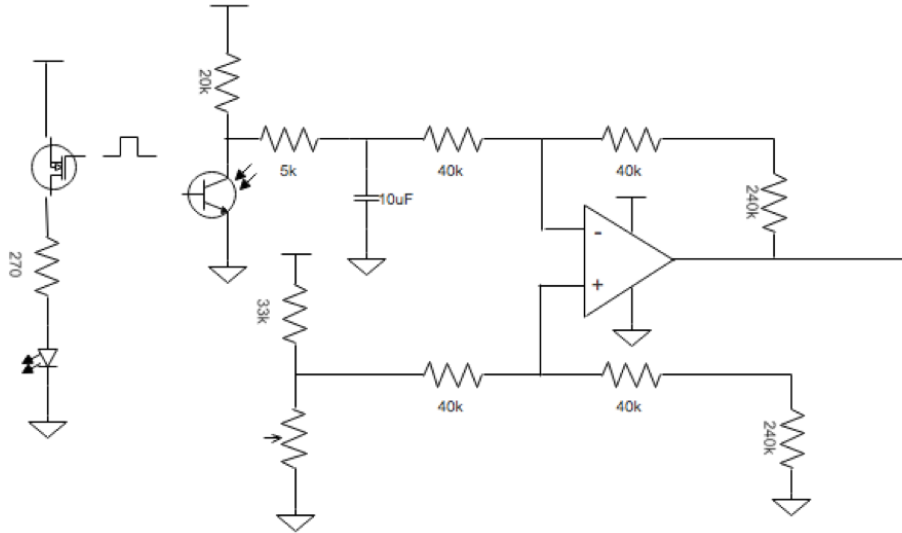

Figure 4.3: Circuit With Instrumental Amplifier

We found that we were able to increase the sensitivity greatly, but we still saw a lot of noise at the output. We placed our sensor and a reference sensor in a clean environment overnight and watched the results. We found that our sensor produced dramatic changes that were linked to noise in our device. Figure 4.4 shows the noise we saw with this sensor.

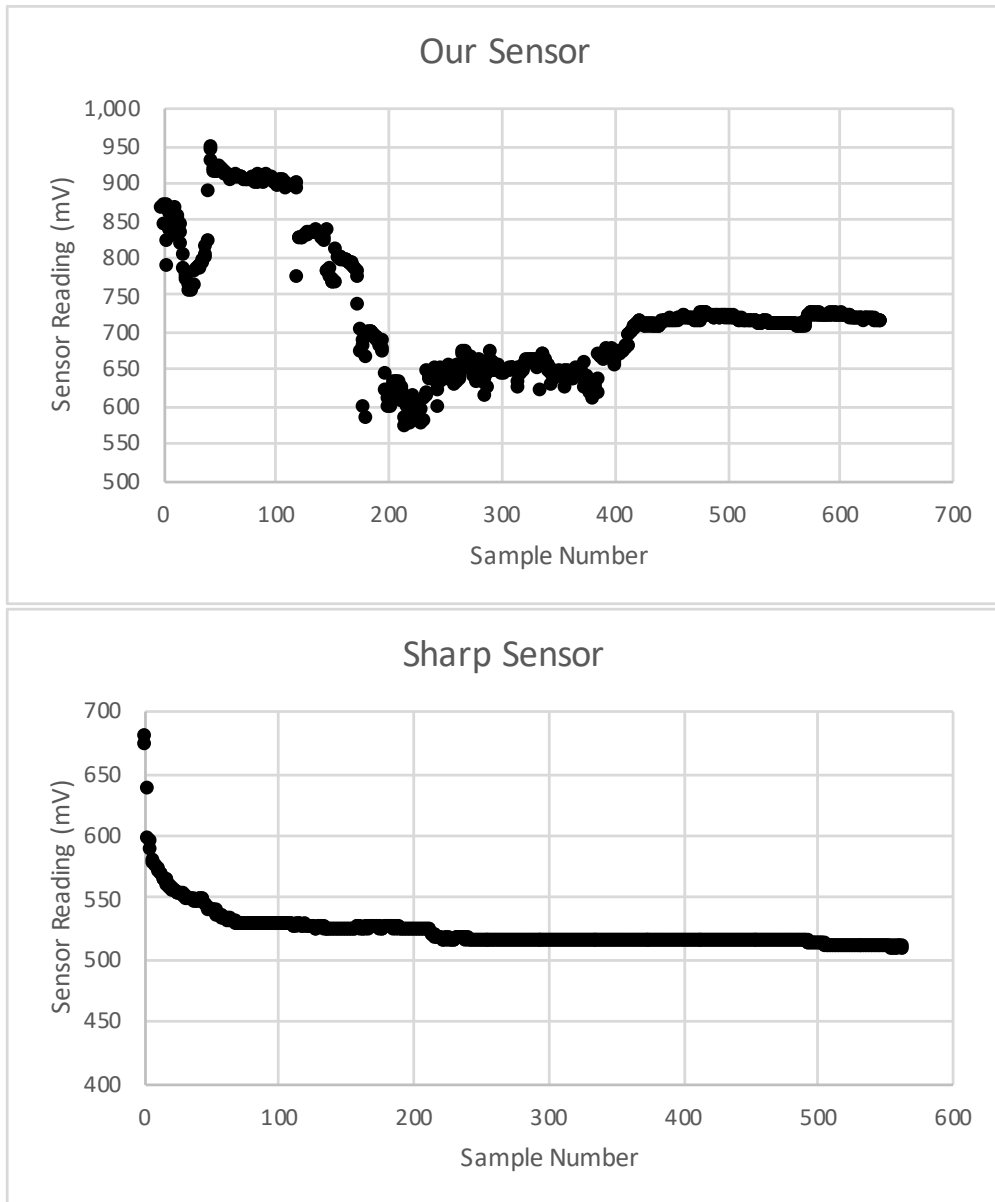

Figure 4.4: Data from Noisy Sensor

### 4.2.3 Final Design

For our final design, we chose a trans-impedance amplifier. It amplifies the current coming from the phototransistor rather than the voltage. Current is often much less noisy than voltage, so this would help us to ensure that we were not amplifying any noise. Next, we used another amplification stage to increase the sensitivity. Finally, we added a passive RC filter with a 20 Hz cutoff frequency at the output. This eliminated any 60Hz noise from ambient light. Figure 4.5 shows the final schematic that we used.

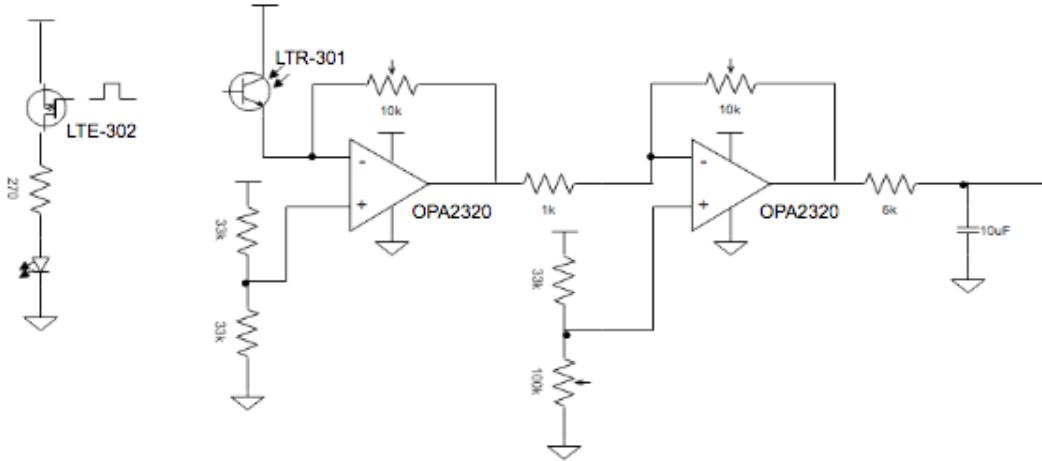

Figure 4.5: Schematic for Custom Sensor

We also found that using breadboards and wires created too much noise for our sensor. We needed to design our own custom PCB for our sensor. Figure 4.6 shows the board layout. With the implementation of the final circuit design and the PCB we saw much less noise and obtained the sensitivity that we desired.

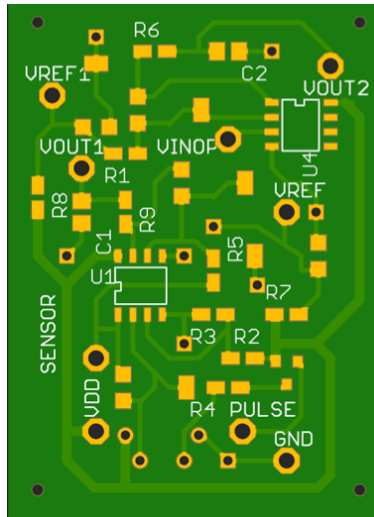

Figure 4.6: PCB Layout for Final Sensor Design

## 4.3 Data Acquisition and Transmission

### 4.3.1 Hardware

Section 3.2 explained the decisions and criteria motivating the selection of a TI CC2640R2F as the microcontroller for our device. The purpose of the device is threefold: to interface with the sensors, perform processing and filtering on the acquired data, and send the data to a user's mobile device. In order to perform all of these tasks, we use a LaunchPad (pictured in Fig. 4.7) from TI that incorporates the desired controller.



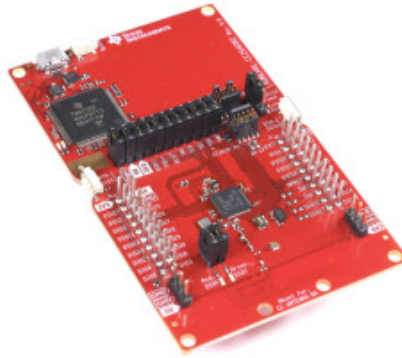

Figure 4.7: TI SimpleLink LaunchPad used for data acquisition and transmission

The LaunchPad also offers an on-board debugger that allows for quick modification of code and easy testing of new designs. On top of this, the board has a built-in Bluetooth Low Energy (BLE) antenna, allowing us to easily communicate between the board and a mobile device while conserving power.

### 4.3.2 Software

Programming the CC2640R2F is accomplished using the Code Composer Studio development environment. The C language is used, and task scheduling for the device is handled by TI-RTOS, a specialized real time operating system for TI microcontrollers. The tasks carried out by the embedded system are diagrammed in Fig. 4.8.

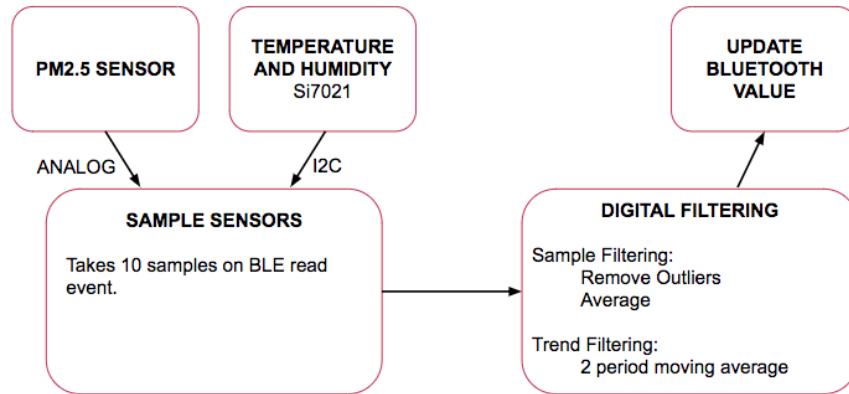

Figure 4.8: Diagram of software processes running on the embedded device

The program flow centers around a main task that manages the BLE connection to another device. This task maintains the connection and handles major connection events. "Read" events, when the phone attempts to read a new value, spawn a secondary thread that samples the sensors. The PM2.5 sensor is sampled through the ADC 10 times, then outliers are removed and the remaining samples are averaged. For added digital filtering, a two-period weighted moving average is computed to come up with the final sampled value. Then, the controller reads the Si7021 temperature and humidity sensor via I2C, and the humidity and PM2.5 values are used to compute an AQI value. Once all of these operations are performed, Bluetooth characteristics for PM2.5, humidity, and temperature are updated, allowing the connected mobile device to see the latest readings.

## 4.4 Energy Harvester

### 4.4.1 Background

Energy harvesting involves capturing small or low amounts energy from an energy source, using a harvesting architecture that consists of energy conversion and energy storage, and then delivering power to a load. A basic energy harvesting system consists of an energy source, a harvesting architecture, power management, and energy storage. Energy harvesting can include radio frequency (RF), thermoelectric, piezoelectric, or photovoltaic sources. Given the current state of technology, RF, thermoelectric, and piezoelectric sources used independently cannot provide enough power to sustain WSNs that use more than a few mW of power.

Despite their varying and weather-dependent nature, photovoltaic sources hold the most promise given their higher energy output compared to the other sources and the sharp decrease in the cost of solar cells over the last decade. Architecture and power management can include step-down regulators equipped with Maximum Power-Point Tracking (MPPT), step-up regulators with MPPT, or some combination of the two architectures. Common energy storage methods include lithium-ion (Li-Ion), lead (Pb), or nickel-metal-hydride (NiMH) batteries. Some exploration has also been done into the use of supercapacitor storage system given their high energy density and ability to effectively manage deep discharge cycles.

### 4.4.2 Initial Design

As mentioned previously, energy harvesting was selected as a way to power our device. The energy harvester functions by taking the varying 0-5 V voltage from a solar panel and into the T.I. BQ25505 boost power converter. From there, MPPT is performed on the energy source as it is harvested. Then, the input voltage is regulated and boosted to a 4.2 V output. Some energy is used to charge the 500 mAh battery, while the rest is used to power the microcontroller and PM 2.5 sensor. A supercapacitor is used as a buffer to the battery. At the output, a Texas Instruments Low-Dropout Regulator, the TPS7A89 was used to maintain the output voltage at 3.3 V so our PM 2.5 sensor and microcontroller could be consistently powered.

For our energy source, solar panels were used after evaluating the amount of energy that could be obtained using photovoltaics in comparison to other energy sources. Initially, we examined using 2 or more solar panels of 250 mW or less to meet our energy production requirement of 500 mW. These panels provided a peak current of 50 mA. However, as we iterated through our design we determined that more current would be needed. As a solution, we incorporated the Seeed Technology Co. 500 mW panel and the Seeed Technology Co. 1 W panel. Each panel provided 100 mA and 150 mA of peak current respectively. Both were used individually throughout the testing of our device.

Next, we selected the harvesting architecture. For our device, we selected a hybrid harvest-store-use and harvest-use architecture. To ensure that when necessary our device could deliver power to the sensors and microcontroller when the battery was full while also ensuring that our device was able to charge when the battery was low. We settled on using the Texas Instrument's BQ25505 for our energy conversion given that it included MPPT, dual energy storage, input voltage regulation, and energy source overvoltage and under voltage protection. Input voltage regulation was especially valuable, given that under heavy light conditions voltage from the solar panel can exceed 5.0v.

Lastly, for our energy storage we settled on using both a battery and a supercapacitor. The supercapacitor would function as a buffer for the battery and assist in decreasing the steep charge and discharge cycles that batteries experience. An AVX supercapacitor and a 500 mAh LiPo battery were used. The size of the battery was calculated using a mathematical model provided by Texas Instruments. The calculations are discussed more in the Energy Harvester Results section.

### 4.4.3 Final Design

After initial testing, we determined several changes were needed. First, while the supercapacitor functioned, in order to properly optimize and storage energy in the device, a supercapacitor balancer was needed. The addition of this component would have proved expensive and overly complicated, thus we decided to eliminate the supercapacitor from our design altogether. Next, we needed some way of evaluating and measuring the state of our battery. So, we incorporated a fuel gauge which gave us the ability to monitor the state of charge, state of health, and power being delivered and consumed by the battery. We selected the Texas Instruments BQ27741 given that it was low-cost compared to other options such as the Maxim 17055. Lastly, we replaced the TPS7A89 with the T.I. TPS26447 buck-LDO. Testing demonstrated that the first LDO was drawing over 1 A of power and severely depleting our energy harvester. For comparison, the TPS26447 dissipated a maximum of 400 mA. The final energy harvester schematic and printed circuit board can be seen in the figures below. Our custom PCB allowed us to reduce the size of the energy harvester so that we could place it into a more compact and efficient casing.

Figure 4.9 shows the final schematic that we used.

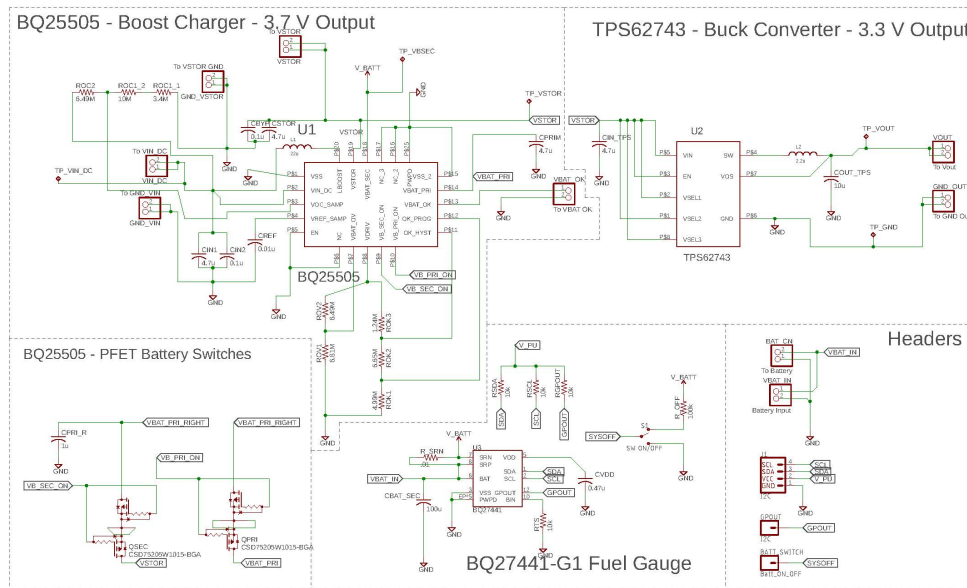

4/20/18 9:13 AM f=0.77 /Users/naeem.turner-bandle/Documents/eagle/Energy\_Harvester/Energy\_Harvester\_Schematic.sch (Sheet: 1/1)

Figure 4.9: Schematic for Energy Harvester

Figure 4.10 shows the final PCB that we designed.



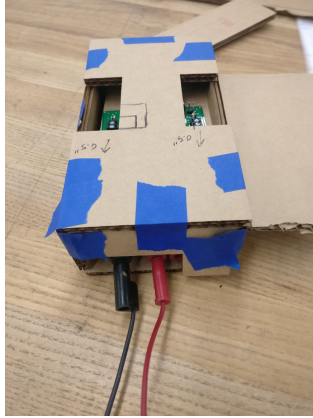

(a) Version 1 of the Energy Harvester Box

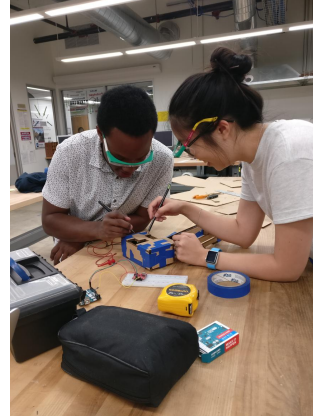

(b) Box Design Discussion

Figure 4.11: Prototype Version 1

### Prototype Version 2

In the second version of the prototype, the height of the box increased so that it would be able to accommodate space for both PCBs and the wall in between them. One of the holes needed to be cut even bigger because one of the pins was not easily accessible based on the current design. A handle was added to the design so that the box would be easy to carry around.

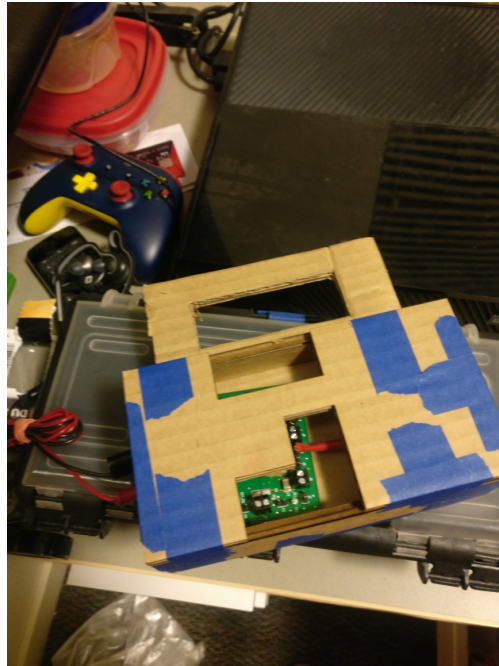

Figure 4.12: Mobile Application Version 2

### Prototype Version 3

In this third prototype of the box, we made sure that the box was able to contain all of the hardware components. We made sure that the components inside the box was easily accessible.

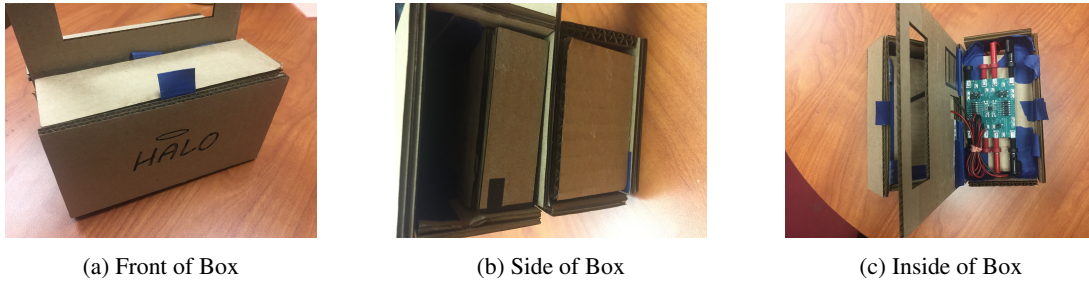

Figure 4.13: Prototype Version 3 of Casing

### Final Boxes

Since we were not able to develop all of the PCBs, we created a larger box that is able to house all of the evaluation boards. This allows us to run our testing. We used a black matte acrylic since black reflects the least amount of light and the matte finish also helps. We used a shiny black finish for the outside of the box to give it a sleek look and feel.

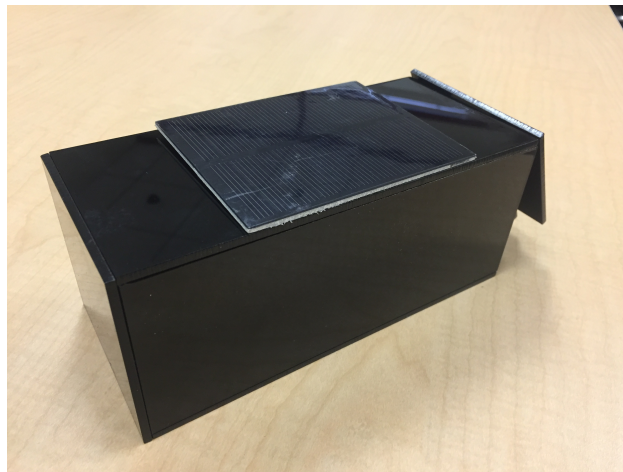

Figure 4.14: Casing for the Evaluation Boards



The smaller box is designed out the same material, but is smaller because that is when all of the PCBs will be manufactured. The small box represents the final size of the portable air quality monitor as shown in Figure 4.15



Figure 4.15: Final Version of Casing

## 4.6 Testing and Results

### 4.6.1 PM2.5 Sensor Results

#### Lab Testing

In order to determine the functionality of the designed PM2.5 sensor, we devised various tests to look at its performance. First, we placed our sensor and a reference sensor in an environment with very clean air and then added smoke to the environment to mimic poor air quality. The results are show in Figure 4.16.

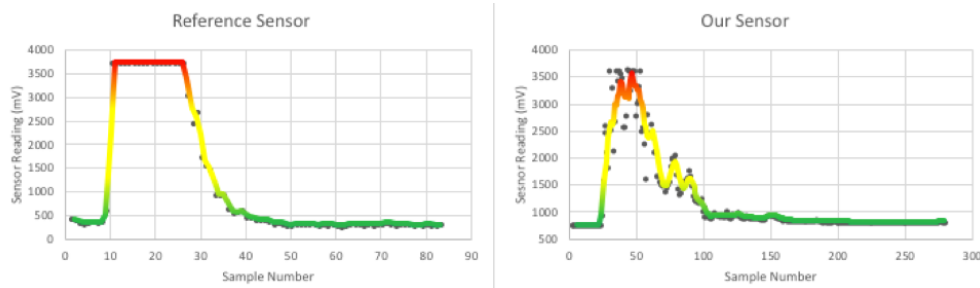

Figure 4.16: Sensor Performance in a Lab Setting

Both the output of our sensor and the reference sensor showed an increase in voltage when the smoke was introduced. As the smoke dissipated, both sensors gradually decreased back to indicate that the air was clear again. Our sensor showed a range much similar to the reference sensor, about 3V. This is enough to give us enough sensitivity to detect fine levels of change in air quality.

## Field Testing

We performed many field tests to determine how our sensor would perform in our actual application. These included tests to look at the long term functionality of our sensor and its ability to pick up fine levels of changes in air quality in the environment.

One field test that we performed was at Washington Elementary School, a school located in San Jose. We tested our sensor with a research grade air quality monitor that Dr. Iris Stewart-Frey and her team use. We found that our sensor behaved much like the research grade sensor did. Figure 4.17 shows the results of the test we ran at the elementary school.

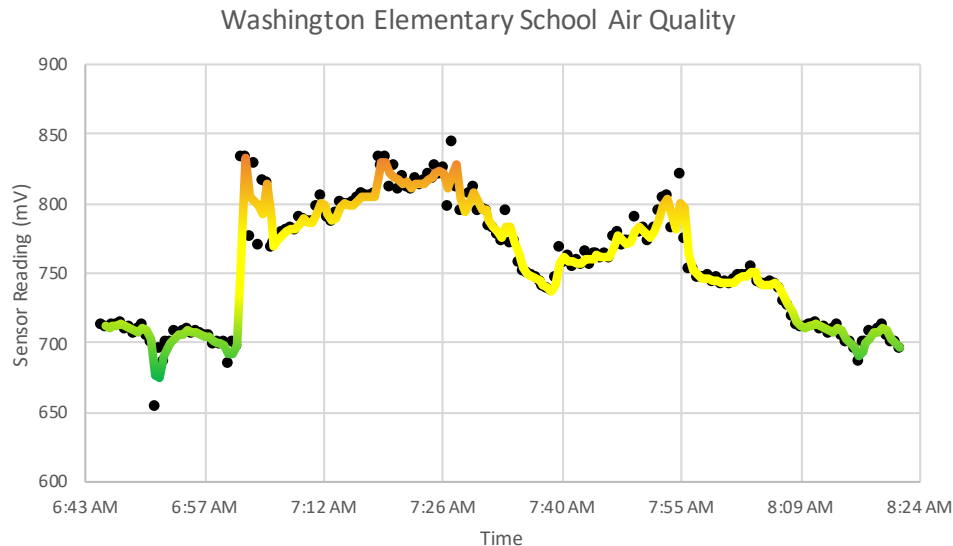

Figure 4.17: Sensor Performance at Washington Elementary School

The green represents the air when we began the test in Santa Clara. The sudden spike in the graph at around 7:00am is when we opened the car door at Washington Elementary School. This told us that the air quality was in fact worse as expected. Then we walked around the school, which is all the yellow part for the graph. The highest spike in the graph is at the location where students enter the school. Through this test, we were able to see that our sensor could detect fine levels of change in air quality. We also determined that placing our air quality monitor at this school could be helpful to Dr. Iris Stewart-Frey's research. This could help to make important findings that could be used to make changes for the students at these schools.

We also wanted to test how our sensor operates over a long period of time. We placed the sensor in one spot outside for approximately two days. This allowed us to see how the sensor performed at detecting the constant changes in air quality that throughout the day. Figure 4.18 shows the air quality measured in this long-term test.



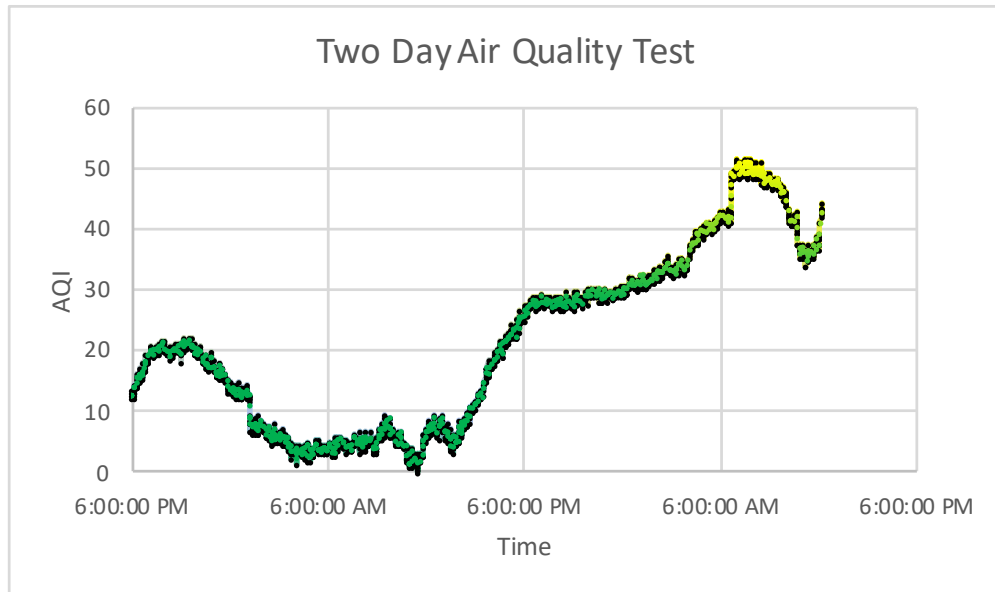

Figure 4.18: Long-term Air Quality Test

We found the the air quality was generally good, with a peak of just above an AQI of 50 for a few hours. This is what we would expect to see for this area. We also were able to see that the air quality seemed to fluctuate throughout the two days, which is what we would expect to see. Overall, this test showed us that our sensor was able to detect small changed in air quality that are constantly occurring.

## 4.6.2 Energy Harvester Results

The energy harvester was tested in several environments. Initial testing was done indoors to verify the bare-minimum functionality of the device. During these tests the key measurements taken were: the input voltage, output voltage, input current, and output current. Once the device performed as expected, testing moved outside. Outside tests were performed in both cloudy and full light environments. The following items were looked at when collecting data: battery state of charge, battery state of health, solar input voltage, energy harvester output voltage, output current, power delivered or consumed by the battery, and current battery capacity. Measurements were taken for one to 5 hours at a time. Unfortunately, we were unable to conduct long-term testing prior to the completion of the project.

Using the initial energy harvester measurements, current and voltage measurements of the PM 2.5 Sensor, current and voltage measurements of the Data Acquisition and Transmission System, and a Texas Instruments mathematical model, we were able to calculate power and energy measurements for our device. These gave us a strong understanding of how our device might perform over the long term. Below, in Table 4.1 are the power measurements for our device.

Table 4.1: Energy Harvester Power Measurements

	Total mAHr/day consumed	Total mWHr/day consumed	Min. Input Power Required for System Operation
Equation	$ISTOR \times \text{Mode Hrs/ Day}$	$VSTOR \times \text{mAHr/Day}$	$\text{Inst. Power/ converter efficiency}$
Estimate	99.609 mAHr/day	370.546 mWHr/day	202.642 mW

### 4.6.3 Final Cost

The final cost the prototype of our device is \$120. The breakdown on the costs are shown in Table 4.2. The areas that were more expensive than we expected them to be were the custom PCBs and the electrical components to use on the boards; however, if we were to manufacturer many of these devices, the costs per device in those two areas will go down significantly. This would put the final cost well under \$99. This means that we achieved our goal of creating an air quality monitor that is much less expensive than current market solutions.

Table 4.2: Final Cost Breakdown for our Prototype

Item	Cost
Custom PCB	\$33
Microcontroller	\$35
Electrical Components	\$32
Solar Panel	\$5
Battery	\$5
Casing	\$5
Total	\$129

## 4.7 Conclusion

In conclusion, our air quality monitor consists of a custom PM2.5 sensor that utilizes an IR emitter, IR detector, amplification, and filtering. A TI CC2640R2F microcontroller processes the data and converts the output of the sensor to an AQI value that the user can easily interpret. The device is powered by solar panel, so it never has to be plugged in to charge. Finally, all of the components are encased in a single module that also includes a testing chamber for the PM2.5 sensor.

The final sensor design was sensitive enough to detect small changes in air quality. It matched closely with the reference sensor during lab testing and seemed to operate correctly in field tests. The energy harvesting system for the device is able to operate the air quality monitor for 24 hours without recharge. Finally, the cost of one module is under the requirement and is only \$120. If this device was to be mass produced, this cost would decrease drastically. Overall, the air quality monitor we created accomplished many of the goals we set out to meet.

## Chapter 5

# Mobile Application

### 5.1 Overview

The purpose of the iOS application is to connect to the air quality monitor that we created with the website that will aggregate all of our user data. The mobile app will connect to the hardware air quality monitor by using BLE. The application provides a simple and easy method of collecting data as well as a way for the users to understand what the air quality is like. Figure 5.1 explains how the data is transferred throughout the system.

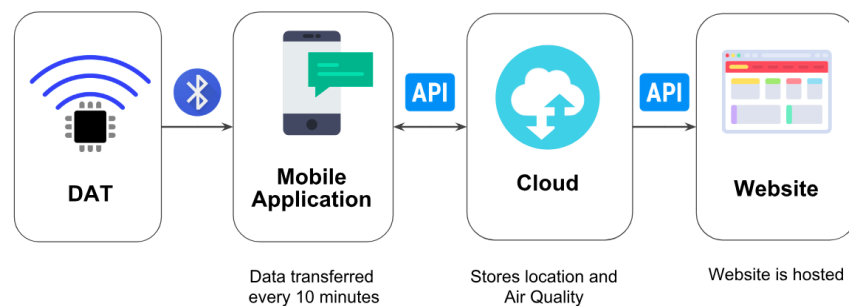

Figure 5.1: Data Transfer Overview

The DAT or TI board transmits the data over BLE. The mobile application polls the DAT every 10 minutes. Once the data is collected, the API, application program interface, will send the data to the cloud. Our cloud is currently Adafruit IO since it is a free service and already had a well documented API explaining how to send data. The website then takes the data from the cloud and then populates and updates the data shown on the page.

## 5.2 Requirements

### 5.2.1 Functional Requirements

The functional requirements are what our system must do in order to be successful. They define what our mobile application must do. These requirements are listed in the Table 5.1. Note that 10 is the most important while 1 is the least important.

Table 5.1: Mobile Application Functional Requirements

Name of Requirement	Importance (1-10)*
Connect to Microcontroller	10
Receive data from Microcontroller about sensor state	10
Display the Air Quality Data on the Mobile Application	10
Display the Humidity Data on the Mobile Application	4
Display the Temperature Data on the Mobile Application	5
Send the results to a website and database to be stored	8
Gather and send users location with data sent to the website and database	3

### 5.2.2 Non-Functional Requirements

The non-functional requirements are constraints that our system must follow and show the overall characteristics and qualities. These are not always easy to measure. These non-functional requirements are listed in Table 5.2.

Table 5.2: Mobile Application Non-Functional Requirements

Name of Requirement	Importance (1-10)*
Intuitive mobile application design	8
Display new updated results quickly	9
Data should be readable and easily understood	8

### 5.3 State Diagram

The state diagram depicts the various states that the mobile application is in. We want the application to be very simple and user friendly. The user does not feel overwhelmed and is able to review the information given quickly. Figure 5.2 shows what the various states of the mobile application are.

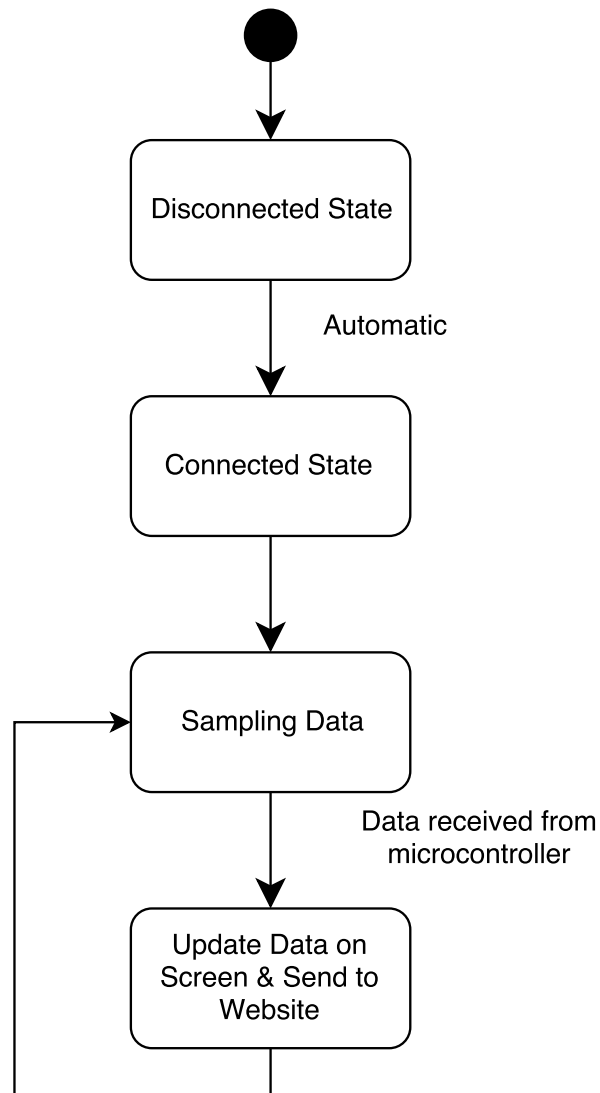

Figure 5.2: Mobile Application State Diagram

- Disconnected State
  - Initiation: The application enters this state the first time the application is opened for the very first time. This pairing only happens when the user downloads the application for the first time.
  - Function: The mobile application needs to be paired with the air quality monitor.
  - Interaction: This state interacts with the TI CR2640 microcontroller
- Connected State
  - Initiation: The application has successfully connected to the TI CR2640 microcontroller and has turned on the green light on the microcontroller.
  - Function: This then allows the mobile application to continue with the rest of the functions.
  - Interaction: This state interacts with the TI CR2640 microcontroller.
- Sampling Data
  - Initiation: This state is automatically entered once the devices have been paired.
  - Function: The application receives the data from the microcontroller and displays them on screen
  - Interaction: This state interacts with the TI CR2640 microcontroller.
- Update data on screen & send to website
  - Initiation: Once the data has been gathered and displayed on the mobile app, the sending data state is initialized.
  - Function: The data is then sent over to the website and database.
  - Interaction: This state interacts with the online database and website.

## 5.4 Use Cases

### 5.4.1 Use Case 1: Connect to Microcontroller

- Actor
  - User
- Goal
  - Connect the microcontroller to the phone so that data can be sent over BLE
- Preconditions
  - Microcontroller must be powered and turned on as well as create a BLE service to connect to
- Postconditions
  - The mobile application is connected to the phone
- Sequence of Steps
  1. User must open mobile application on their phone
  2. The mobile application will automatically connect to the microcontroller and notify the user that it has been connected
- Exceptions
  - None

## 5.4.2 Use Case 2: Collect Data

- Actor
  - User
- Goal
  - Collect data on air quality, temperature and humidity
- Preconditions
  - Mobile application is connected to the microcontroller
  - Microcontroller is connected to the relevant sensors such as air quality, temperature and humidity
- Postconditions
  - Mobile application updates the data displayed on screen
  - Mobile application sends data to the website/database
- Sequence of Steps
  1. User waits for 5 seconds
  2. Data from the microcontroller is then updated on the screen
  3. Data is then sent to the website/database
- Exceptions
  - None

## 5.5 Results

### 5.5.1 Mock-ups

The designs that we came up with for the mobile application. We wanted to create a simple interface that allowed users to quickly receive the information. The sketches of the potential designs are shown in Figure 5.3

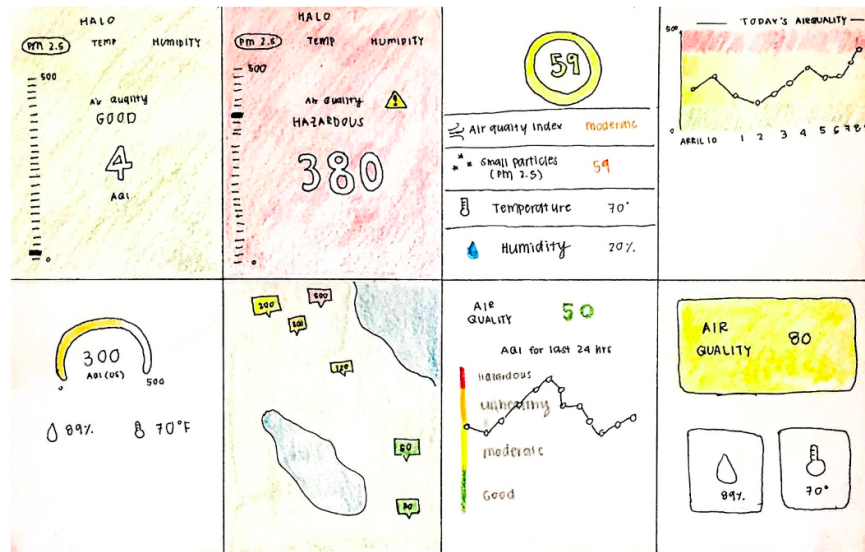

Figure 5.3: Mobile Application Mock-up



## 5.5.2 Prototypes

### Version 1

This is the first working version of the mobile application on iOS. The first prototype is shown in Figure 5.4

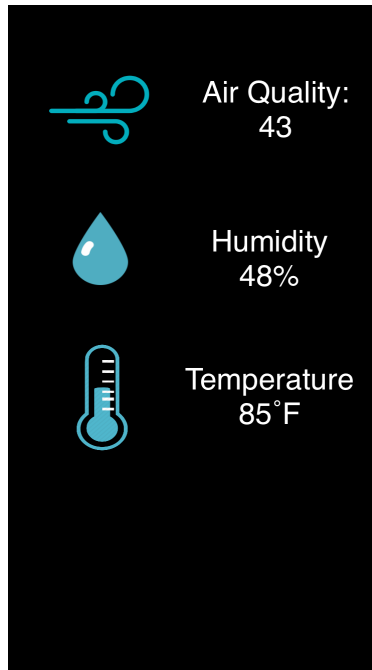

Figure 5.4: Mobile Application Version 1

The application is able to connect to the air quality monitoring hardware and turn on the green LED. Once the iOS application has established the connection, the application begins to immediately read the data that was sent over Bluetooth. The mobile application displays the data on the screen to the user and continuously updates the value every 5 seconds. The data is also sent to the website [io.adafruit](http://io.adafruit) where the data is stored and graphed.

## Version 2

This is the mock-up of the refined design of the mobile application. Since Version 1 was just a functional prototype, we wanted to make a prototype that had the look and feel of the end product. The second mock-up is shown in Figure 5.5 and was made to showcase what the final design would look like. This mock-up was created using the website creately.com.



Figure 5.5: Mobile Application Version 2 Mock-up

### 5.5.3 Final Version

The final application seen in Figure 5.6 is able to display the current air quality when connected to the device.

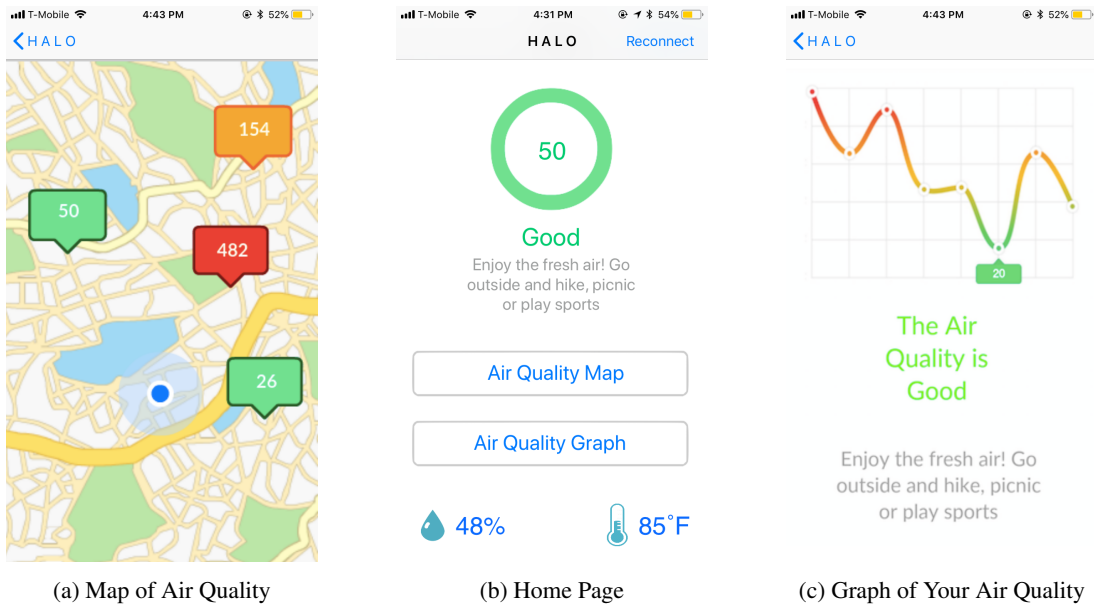

Figure 5.6: Final Version of Mobile Application

The button in the top right corner toggles between connected and reconnect. This allows the user to know when the device has been disconnected. We have also been able change the color of the circle and update the suggestions based on the level of pollution. This is extremely important as it shows that we are able to easily communicate to the user what the air quality is like and what actions they should take in real time.

# Chapter 6

## Web

### 6.1 Overview

The website's purpose is to be able to display the aggregate data in a meaningful way such that users are able to have an immediate understanding of what they should do. The website is easily accessible through any mobile device or computer with internet capabilities.

### 6.2 Requirements

The functional requirements are what our system must do in order to be successful. They define what our website application must do. These requirements are listed in the Table 6.1. They are based on a scale from 0-10 where 10 is extremely vital to our system and 0 being a nice feature that should only be implemented if time permits.

Table 6.1: Website Functional Requirements

Name of Requirement	Importance (1-10)*
Display Aggregate Map	10
Get Data From Cloud	10
Graph Current Air Quality	9
Graph Air Quality with Colors	8
Update Website in Real Time	5

## 6.2.1 Non-Functional Requirements

The non-functional requirements are constraints that our system must follow and show the overall characteristics and qualities. These are not always easy to measure. These non-functional requirements are listed in Table 6.2.

Table 6.2: Website Non-Functional Requirements

Name of Requirement	Importance (1-10)*
Intuitive Website Design	8
Display new updated results quickly	9
Data should be readable and easily understood	8
Aesthetically Pleasing	7

## 6.3 Solution

First we set up an Oracle Database to store all of the air quality results that we had received from the microcontroller. The first mockup of the website can be seen in Figure 6.1.

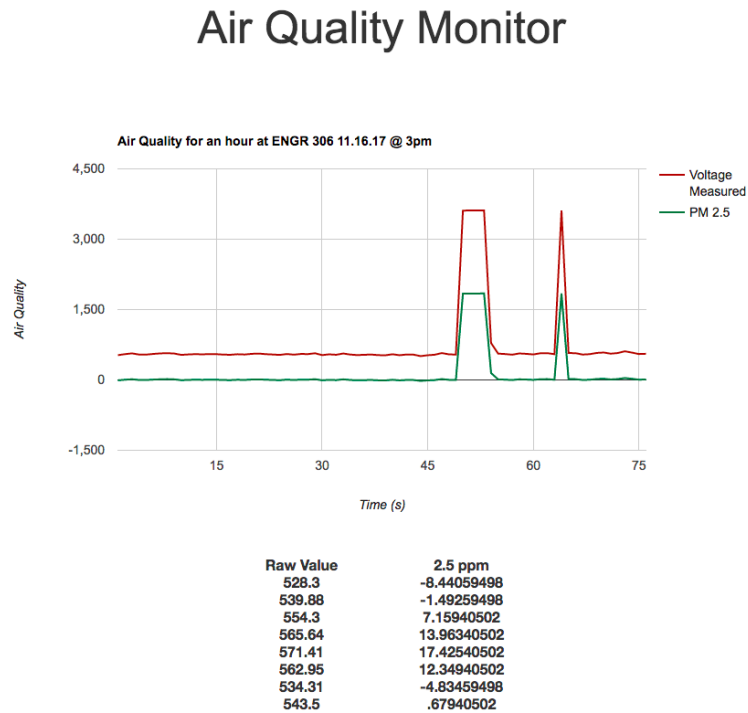

Figure 6.1: Version 1 of the Website

The SQL database stores all of the data on the Oracle server. We used Google Charts in order to display the graph. When the mouse hovered over the graph, a small window would popup showing the user what data point he or she was looking at.

The website then needed to have an additional map and display the temperature and humidity which can be seen in Figure 6.2.

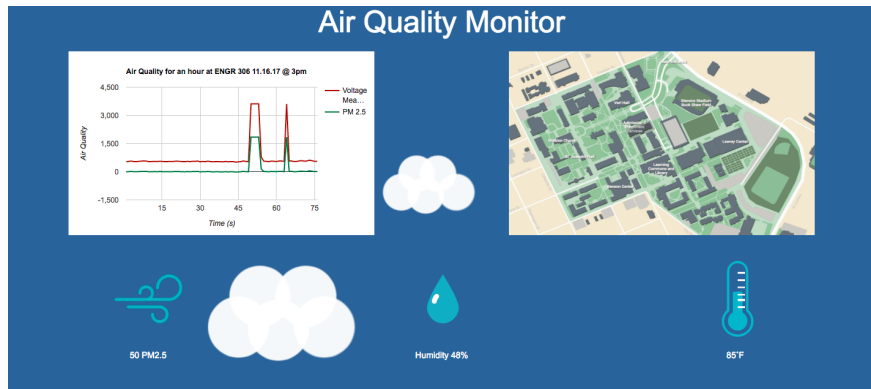

Figure 6.2: Version 2 of the Website

Bootstrap was then used on the website to ensure scalability and a photo of campus was taken to simulate where the live map would eventually be placed. The moving clouds in the background were to make the website more fun for users.



Figure 6.3: Version 3 of the Website

However, it became clear that we needed the website to be a little more clean and thus we introduced version 3 of the website shown in Figure 6.3. This website featured a map implemented using the Google Maps API. The map was able to display a pop-up informational window when the location icon was clicked. This allowed the users to fully understand the data at that point. After reformatting the website with Bootstrap, we moved on to our next design.

This design in Figure 6.4 featured a more functioning graph.

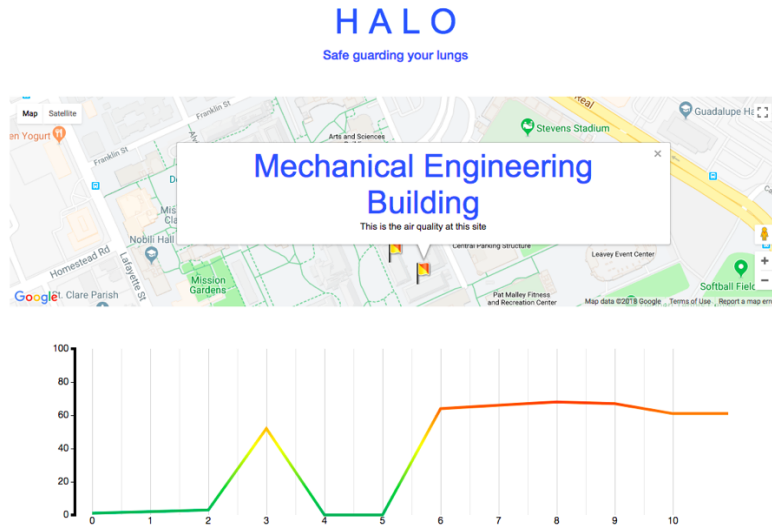

Figure 6.4: Version 4 of the Website

The graph that was created using Google Charts would not do so we moved over to using D3, a visualization library that allowed us to customize the colors of the graph. The graph is able to change from green to red. This change in color allows the user to quickly understand the differences in air quality. Figure 6.4 shows the graph that much easier to understand.

The final version of the website combines these features together. The aggregate map is shown on the bottom right corner of Figure 6.5.

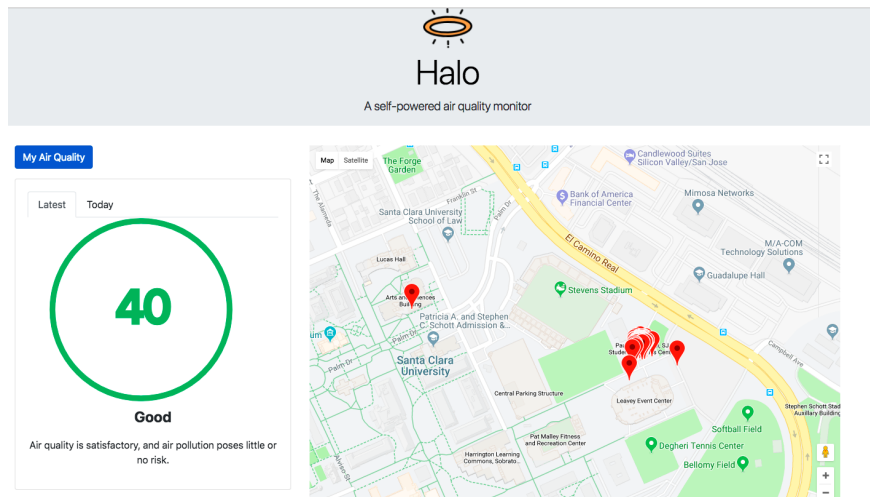

Figure 6.5: Final Version of Website

The green circle shows the current air quality and shows a suggestion of what to do below it. This suggestion is consistent with the mobile application and stems from the advice from the AQI chart in Figure 3.1. The website is able to update in real time and the graphing of the data is done by React library. The React library also helps the website be developed more modularly, so we are able to focus on one item at a time. Webpack was used in order to compress the



website so that it is able to load quicker. This is extremely useful when loading a website onto a mobile phone since the data transfer rate is not normally as high as a computer. The rotating Halo at the top adds a little bit of fun to the website.

## 6.4 Testing

We wanted to check the functionality of our website integrated with all of the other components of our device. To do this, we walked around Santa Clara University's campus for 45 minutes and used our device to measure the air quality we walked. Figure 6.6 shows the graph of the air quality measured as we walked around. Figure 6.7 shows the path we took as we walked around campus.

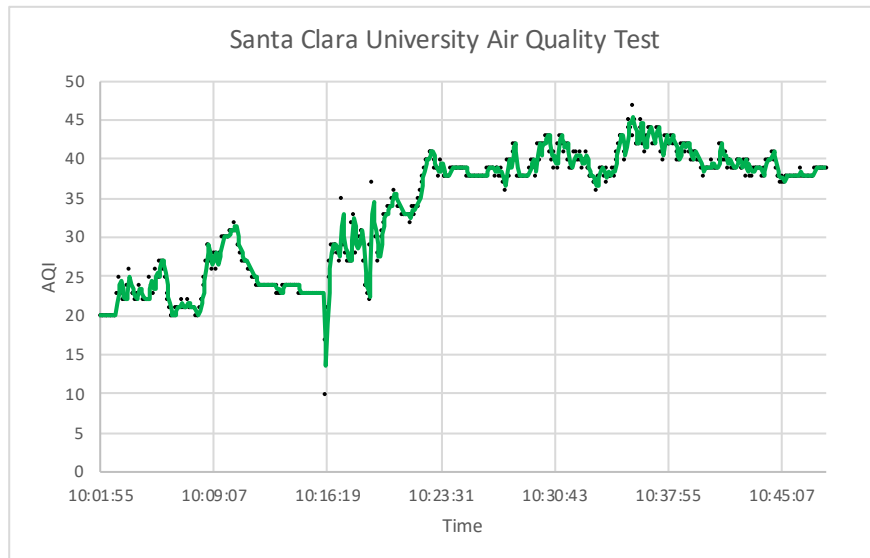

Figure 6.6: Graph of Air Quality in SCU's Campus

Figure 6.6 shows that overall, the air quality on campus was good. It did fluctuate slightly as we walked around. There was an upward trend, which is likely caused by the air quality getting worse overall rather than one specific location on campus having worse air quality.

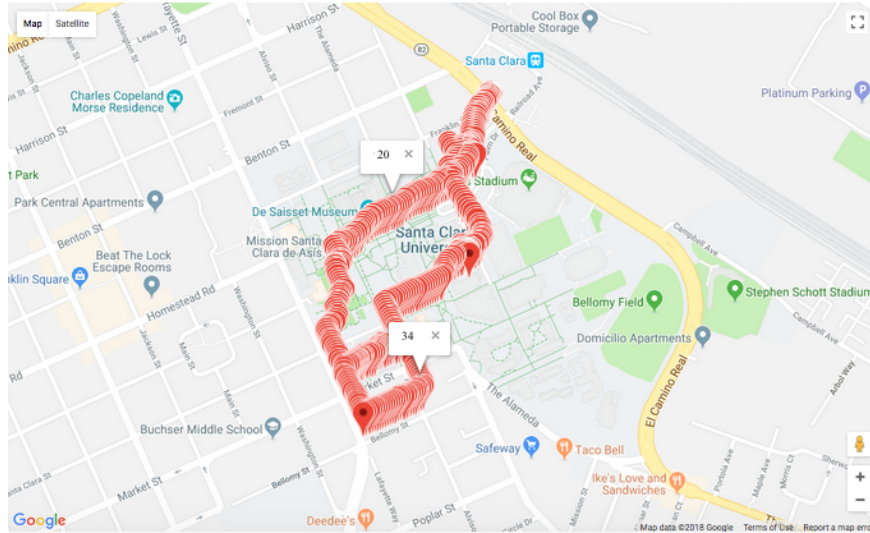

Figure 6.7: Map of the Walk We Took

Each of the red pins on Figure 6.7 shows a place where data was taken. If we click on the pin, the AQI value will be displayed. There are two AQI values highlighted to show the functionality. Connecting the AQI value with a location will help users to easily detect where areas of poor air quality might be.

# Chapter 7

## Social Issues Analysis

### 7.1 Ethical

#### 7.1.1 Section I: Senior Design and Ethical Justification for project

Air pollution, both natural and man-made, poses a hazard to our health and to the integrity of our ecosystems. Most pollutants are invisible to the eye (Brugha and Grigg 195), even in harmful concentrations, and they only have serious health repercussions in the long term, resulting in a lack of awareness and urgency surrounding the problem. Most people would be shocked to learn that air pollution-related illnesses resulted in 7 million deaths in 2015 (Scutti). This gap in knowledge, coupled with the scarcity of air quality data, poses a moral quandary, as individuals cannot make informed decisions for their health without

1. Understanding the risks
2. Being able to measure their risk factors

The Rights Approach from the Markkula Center for Applied Ethics's "A Framework for Ethical Decision Making" defines an ethical action as "the one that best protects and respects the moral rights of those affected" (Velasquez, Manuel, et al). This principle applies to an individual's right to know about air pollution, as it poses an unnecessary risk to life and well-being. Existing air quality monitors are aimed at scientific research, providing clear differentiation between pollutants and high accuracy in measurement; however, such devices are prohibitively expensive, and cannot easily be carried around on one's person. The localized nature of pollution calls for a personal, portable, inexpensive device to protect and respect the human right to clean air through accurate, timely information.

Additionally, aggregating data from many devices allows the construction of high-resolution pollution maps showing air quality trends. Such data allows regulatory bodies to make informed policy, or if regulatory bodies fail to take public health risks seriously, gives citizens support to lobby for action to protect the lives of those in the community.

On top of the public health risks, air pollution can disrupt entire ecosystems. All of the systems on the planet are intricately linked together, and even small disruptions can create natural catastrophes that come back and impact human lives. It is to our benefit to work in harmony with our natural environment, increasing the quality of our own lives and ensuring that the planet remains a safe place for all species that inhabit it. The Utilitarian Approach from the Markkula Center for Applied Ethics's "A Framework for Ethical Decision Making" encourages us to look at how the net damage pollution causes to both our communities and the environment (Velasquez, Manuel, et al). Leaving pollution unmonitored allows the damage it causes to go unnoticed. The health benefits for both our communities and the environment provide strong ethical justification for our air monitor project.

## 7.1.2 Section II: Senior Design Project and Virtues of Being a Good Engineer

In the introduction of the Santa Clara University “Engineering Handbook,” the School of Engineering outlines several essential virtues of a good engineer, including knowledge, compassion, lifelong learning, and experience. Throughout our design and testing, we incorporated the good engineering practices espoused by the handbook. Our teamwork and technical competence allowed us to create a solution that is techno-socially sensitive, respectful of nature, and committed to public good. The following sections outline the engineering virtues that guided us during our senior design project.

### Techno-Social Sensitivity

As our project involves introducing a new technology into society, it is important to recognize the possible effects of this technology, following the IEEE Code of Ethics “to improve the understanding by individuals and society of the capabilities and societal implications of conventional and emerging technologies, including intelligent systems” (“IEEE Code of Ethics”). Our air quality monitor is small and simple, and it will not require intensive training or behavioral shifts to use. However, it is important to keep the public informed about what their interactions with the device mean. We can easily have our air quality monitor display the AQI value and leave it at that, but as good engineers we want to provide users with more valuable information such as

- What toxins are being detected
- How these toxins are harmful
- What risks are posed to whom by current pollution levels
- What actions can be taken to avoid unhealthy exposure

Additionally, we must take into account how society will shape our project. In order to make an effective device, we must be compassionate towards our users by gearing our design towards their needs. We recognize that if we want users to carry our device around, it must be small and easily attachable to backpacks or purses. Technology and society are closely intertwined, so it is important for us to practice the virtues of a good engineer and recognize the possible implications of introducing a new technology into society, as well as how society will shape our technology.

### Respect for Nature

The biggest direct impact of our project on nature is power consumption of all of our sensors. The Utilitarian Approach from the Markkula Center for Applied Ethics encourages actions that cause the least harm to the environment. Mindful of this, our project is “green,” harvesting all of the power for our devices from solar energy, rather than plugging them into wall outlets. A 500 mW solar panel allows for continuous operation, and the 1500 mAh Lithium-Ion battery allows the device to run for over 24 hours without receiving power input from the solar panels.

There are also some cases where our device might not be used as a portable device. For instance, we considered permanently mounting devices outside schools located near freeways to monitor the quality of air that students are breathing to ensure it is not hazardous. In this application, the device could be mounted so that the solar panel is getting as much sunlight as possible, allowing our device to run for years without ever needing to be plugged in. Not only does this make it easier for the end user, but it also ensures that our device does as little harm to the environment as possible.

## **Commitment to Common Good**

Air quality is an issue common to people throughout the world, disproportionately impacting impoverished and heavily populated areas. People often have no means of measuring their air quality, which leaves them unaware of a key health risk. Inspired by the Fairness or Justice Approach from the Markkula Center for Applied Ethics, we place major emphasis on designing an inexpensive system that can be used by people anywhere, regardless of their economic standing. In this way, our project can contribute to the public good, rather than a small audience with the economic means to buy an expensive sensor.

## **Teamwork**

Additionally, the teamwork inherent in this project supports our growth as good engineers. Many of the IEEE Code of Ethics rules support collaboration, including “to seek, accept, and offer honest criticism of technical work, to acknowledge and correct errors, and to credit properly the contributions of others” (“IEEE Code of Ethics”).

We emphasized being open to criticism, listening to each others’ ideas and keeping an open mind, even when they differed from our own. We also listened to criticism provided by our faculty advisors, other faculty members, and industry partners, so that we could improve our design based on their feedback. The first idea is rarely the best, so this acceptance of criticism is a critical virtue of a good engineer.

Another IEEE Code of Ethics guideline requires engineers “to improve the understanding of technology; its appropriate application, and potential consequences.” We tested many sensors, learning from the operation of each one. Some were too inaccurate or required too much power for our application, but we were able to adapt many of the concepts to a more appropriate solution. We also experimented with sources of harvested energy attempting to get a modicum of extra energy from sources that were not always reliable.

The IEEE Code of Ethics also requires us “to be honest and realistic in stating claims or estimates based on available data” (“IEEE Code of Ethics”). Throughout our tests, we took care to only report accurate data, and to avoid any misleading interpretation of results. Further, we emphasized safety throughout the project, working in pairs when in the lab and only using equipment after receiving proper training. This meets the following two guidelines of IEEE Code of Ethics:

- “to maintain and improve our technical competence and to undertake technological tasks for others only if qualified by training or experience, or after full disclosure of pertinent limitations”
- “to avoid injuring others.”

### **7.1.3 Section III: Senior Design Project and Safety, Risk, the Public, and Informed Consent**

Finally, the Common Good Approach from the Markkula Center for Applied Ethics’s “A Framework for Ethical Decision Making” encourages our group to look at the public impact of our device. By using our device, individuals and families are placing their privacy and safety at risk. Users gain invaluable information about the quality of the air, but they also expose themselves to the risk that their data could be used by government officials and corporations to make improperly motivated decisions about their health. A chief concern of this team was the impact our air quality monitor could have on schools and the healthcare industry.

Schools in low-income areas near highways could be closed if the air quality in the surrounding area is deemed hazardous. This could disrupt the education of students who may not have affordable and accessible alternative education options. At the same time, this risk could be deemed acceptable if children are being exposed to harmful pollutants that endanger their long-term health. Exposure to pollutants can also lead to increased illnesses and decreased school attendance, increasing the benefit of air monitoring for schoolchildren.

The healthcare industry might also have an interest in our project. The personal air data and aggregate pollution maps provide useful health informations. Doctors and public health officials can gain greater insight into the health risks air pollution poses for individuals and take measured action to improve the health of communities. Conversely, insurance companies can use this data to deny health coverage or increase costs for individuals living in more polluted areas. Without access to affordable, life-saving medical treatments, individuals could see a decrease in their life expectancy.

Given the risks to the safety and privacy of individuals, we are taking several steps to secure consent and minimize risk to users.

1. We reviewed local, state, and federal environmental and privacy laws to ensure compliance.
2. We sought recommendations and approval from experienced researchers on our data collection and information dissemination methodologies.
3. We ensured that user data was stored and maintained in a secure cloud database.
4. User data is encrypted.
5. GPS location data is not tied to identifying information.
6. Points on the aggregate map are displayed as a heat map, hiding individual user locations.

Upon completing these steps, we created an ethics guide to inform users of our privacy policy, how their data was secured, and how their data could be used by government officials and corporations. Additionally, before placing the device in or around any schools, we briefed school officials on the risks and our ethics guide. These actions satisfy the “informed” portion of informed consent, while the “consent” element is satisfied by allowing users to opt in or out of their data being used for our aggregate maps.

## **7.2 Sustainability**

### **7.2.1 Environmental Sustainability**

There are several resources needed to successfully implement our Halo air quality monitor. Looking into the basic materials of our device, the components for creation are solar cells, LEDs, resistors, capacitors, op-amps, inductors, solder, lithium-ion batteries, copper, nickel, gold, palladium, silver, epoxy, chromium, tin, zinc, fused silica, carbon black, doped silicon, and a computer. For the casing design, a computer, 3D printer, and laser cutter are needed. To produce the PCB and device electronics, a plotter, film Sheet, copper foil, epoxy resin, optical inspection machine, PCB prepreg, drill, ink-jet, and x-ray locator are required.

If the air quality monitor was mass produced then we would have to make strategic decisions about time, shipping and packaging materials, and transportation. Operational resources for mass production would include personnel and software to manage the supply chain, resources for troubleshooting and repair, as wells as teams to deal with sales, accounting, marketing, and finances.

The resources used for the construction of the air quality monitor could introduce several pollutants into the environment. Disposing of the materials in a landfill after project completion could contribute to significant environmental and personal harm. For example, improperly disposing of the lithium and lead used in the air quality monitor could contribute to human birth defects, brain damage, heart, liver, lung and spleen damage, and kidney damage. Once these materials are incinerated, melted down, or put in landfills the toxins they emit can be released into the air. This would contradict the purpose of our project. We would be exacerbating the problem that we set out to solve.

We believe the lifetime of our product will be similar to that of other consumer electronics. Most customers will use the product 2-3 years before tiring of the product or being captivated by something new. Ideally, a new version of the

air quality monitor would be released by then for customers to purchase. The total lifetime of the product will most likely be 10 years max before the product needs to be replaced. The battery within the device could last up to 20 years but regular device wear and tear will surely reduce the overall product lifetime. The solar panels on the device could be reused after a user is finished with the air quality monitor since most panels last 25 years. Once the panel lifetime expires, customers will need to recycle the panels so that they do not increase the current 6500 tons of solar panel waste in the U.S.

## **7.2.2 Social Sustainability**

The need this project satisfies has not been well-understood or well-articulated in the past, but it is a topic that is beginning to come into the global conversation. It's common knowledge that pollution has a negative impact on the environment and that exposure to high levels of pollution could be hazardous to health, but very few people recognize that hazardous levels of pollution exist on a regular basis in most large cities. Particulate matter in city air is increasing and can be directly tied to increasing respiratory health issues. By providing the users of our project with an accurate picture of the pollution they are exposed to on a daily basis, we can empower them to make decisions to benefit their health. If they find that they are out and about voluntarily during hours of poor air quality, they can alter their schedule so they can avoid these hazardous conditions. If their typical running route takes them along a busy road with high pollution, they will be able to recognize this and select a different route that would protect their respiratory health.

This value will be easy to obtain from the device. Users would be able to purchase the device online or in a store. It will be small enough to be clipped onto a backpack or purse, and will automatically send data over Bluetooth to the user's phone. From the user's point of view, they will be able to simply take the device with them during their day and check in from their phone or a website to see a live dashboard displaying their current air quality (and a quick description of what that level means for their health), as well as a chart displaying the past data, so they are able to view a historical record and find trends.

Other more specific uses we discussed include measuring particulate matter exposure to firefighters and in schools. Firefighters are constantly exposed to toxic fumes and high levels of particulates, and consequently, face a much higher risk of cancer. For schools, especially those in the inner-city, proximity to highways is suspected to expose children to risky levels of particulate matter. Children are particularly sensitive to air quality and can develop asthma or other respiratory issues in response to consistent exposure to pollution.

Possible negative impacts to user welfare can occur when air quality data cannot be acted upon, or when acting to improve health could cause other negative side effects. For instance, if a school is deemed to have poor air quality and the environmental causes of this issue cannot be easily remedied, the choices are to either continue exposing the children of the school to poor air, or to close and/or move the school, disrupting the children's education and placing new strains on their families. Additionally, once air quality measurements become more widespread and reliable, health insurance companies may use it to justify charging higher rates to individuals living in areas with high pollution.

## **7.2.3 Economic sustainability**

One of the first things to look at in terms of the economic sustainability of our project is how it compares to current solutions on the market. Most of the air quality monitors currently on the market cost over \$200. This is fairly expensive and drastically limits the audience that these devices can reach. These devices are also only meant for household use and must be plugged into an outlet for power. The only portable air quality on the market is not available for sale until June 2018. The current air quality monitors on the market tell us that there is some demand for a product like ours. The product we have created is also much cheaper than the available devices. Our one-off prototype costs \$120, and optimization for bulk sales would easily bring that to under \$100. Our device is also portable, which will make it more appealing to users. This will make our device very competitive in the already existing market for air quality monitors.

One unique feature of our device that will increase the economic stability of our product is that it is powered by harvested energy. This means that the user will not face any additional costs after buying the product. The user will not have to spend money additional buying batteries or chargers. This feature will be very appealing to users. This means that our device will also require no extra maintenance on the part of the user. They should simply be able to pull it out of the box and start using it. The simplicity of our product will also increase the likelihood that users will gravitate towards our product as opposed to others.

One of the biggest hurdles that our device must overcome to profit is that many people are completely unaware that air quality is a problem. They don't realize it is something that they need to monitor. Although there is some demand for air quality monitors, as evidenced by the devices currently on the market, this demand is not huge. If a majority of the population cannot see the utility of an air quality monitor, then our product will fail. However, more and more statistics point to pollution as a growing epidemic in the world today. As more of these statistics come out, people might be more interested in finding out the quality of the air they are breathing. Also, Google Maps has begun to produce air quality maps of cities, albeit not on the block-by-block resolution our device could achieve. However, this could still show people that air quality might not be as good as expected, and leading them to want to track their own exposure with a personal device like ours. Overall, in order for our device to be economically sustainable, there must be a demand from customers to track their air quality; however, as the public becomes more aware of the dangers of pollution, there will likely be a large demand for products like ours.



## Chapter 8

# Future Work

As designed, the sensor provides a solid proof of concept, illustrating that a small, low-power, inexpensive sensor is capable of making fine air quality measurements. As-is, the device can provide valuable information to end users in an intuitive manner. However, given more time, there is much more that can be done to improve the final device. Key advancements and improvements are listed in Table 8.1 and further explicated in the following sections.

Table 8.1: Future Work to Be Completed

Objective	Motivation	Method
Condense Form Factor	Improved portability	Print and integrate PCBs Explore solar form factors
Integrate Additional Sensors	Increased pollutant sensitivity Remote monitoring of battery level	Integrate sensors into DAT system
Deploy Mobile App	Expand potential users	Ensure Apple Store compliance Develop Android application.
Establish Sensor Network	Increased data collection Improved map data	Build and distribute more sensors.
Machine Learning	Meaningful data analytics Trend prediction	Test algorithms on map data

### 8.1 Condense Form Factor

Further shrinking the size of the device to a portable size would require us to move away from the bulky evaluation boards we are using for the energy harvesting system. During the project, we were unable to print the custom energy harvesting PCB due to time and budget constraints, and so the footprint remains large until we can order the new PCB. Integrating the energy harvesting, controller, and sensor circuitry onto a single PCB would help us to further shrink the form factor. Another constrain on our device size is the solar panel, which could be improved with alternate technologies like flexible solar panels that would wrap around the casing of the device, giving us more panel area, more power, and more flexibility in design.

## **8.2 Integrate Additional Sensors and a Fuel Gauge**

We have additional pollution sensors for carbon monoxide (CO) and volatile organic compounds (VOC), but we have not yet integrated these sensors into our device. Expanding our pollution sensitivity beyond PM2.5 would help us to alert users to more possible hazards in their environment, improving the overall effectiveness of the device. We also have a fuel gauge we would like to integrate into the design, so the user could monitor the battery's state of charge. This is particularly important given the device is powered from inconsistent sources like solar energy.

## **8.3 Deploy Mobile Application**

As of now, our mobile application is being developed on one of our iPhones. We would like to deploy it to all potential users, which requires us to get a licence to push the app onto the Apple store. We will need to ensure compliance with Apple's policies and rules so that the application is approved to be placed on the App Store. We also want to port our app to Android to increase the number of potential users for the device.

## **8.4 Establish Sensor Network**

A major goal for our project was the creation of a network of air quality sensors that could be aggregated into crowd-sourced pollution maps. Now that we have produced a functional sensor, we hope to replicate the design and distribute it to multiple users, allowing us to collect data on a much wider scale. Distributed sensors will allow us to create city-wide air pollution maps to pinpoint areas of very poor air quality and begin finding geographic or temporal trends.

## **8.5 Machine Learning for Data Analytics**

Finally, an important area of future work would be the development of machine learning algorithms to interpret the data from the air monitor network. From this data, we can predict air quality trends based on collected pollution and weather data. By synthesizing data from these various sources, we can better inform users and government entities how to mitigate the damage from air pollution.

# Chapter 9

## Lessons Learned

Working on Halo imbued in us a number of valuable lessons related to project management and scope, communication, integration, and testing.

### 9.1 Project Timeline

First and foremost, we learned that you must develop a reasonable timeline that properly addresses the scope of your project. We set out to develop a network of air quality monitors that could be visualized through both a mobile app and website, but in the end only created one device. This taught us that creating a fully realized set of products is quite different than producing a hobbyist project. It requires a level of care and detail that we had not accounted for at the start of our senior design project.

### 9.2 Design Challenges

We encountered a number of challenges in our design process that we had not previously anticipated. There was significant difficulty obtaining an accurate PM 2.5 sensor, we iterated through a number of non-functional power converters, and our mobile and web development process progressed slower than anticipated. Something we could have done to improve all of these low points was to improve our communication between one another and with friends and professionals who had the resources to assist us.

### 9.3 Software and Hardware Integration

Additionally, in our initial project timeline we failed to account for software and hardware integration. One of the most arduous tasks of the project was integrating the hardware and software. For too long, we each worked individually in our own silos attempting to perfect our section of the project. This was a mistake because it left us without knowledge of what the other person was doing and did not make us ponder about how we create an end-to-end demonstration. By the time we realized this, we were too far behind to make up the time. We should have started working together much earlier on at least seeing how each part would connect to the other. Significant time was spent discussing how it would work but not enough action was taken.

## **9.4 Website and Mobile Application**

On the software side, there was a lot of time wasted since we kept redesigning both the website and the mobile application. Because of this, we spent many hours working with different libraries that we did not end up using for our final design. Our lack of planning caused us to waste time developing features that did not carry over into the final design. It is important to plan out what is important in the mobile application and website. Although it might not be clear what exactly the final design should look like, it should be something that is more thought through.

## **9.5 Evaluation Metrics**

Finally, creating quantitative metrics to effectively test our device was challenging. The nature of our project required that we have metrics to verify the functionality of individual components as well as the entire system. This was not thought of until the end and should have been something we considered in the summer or the fall. Had we considered these things earlier so that we could have worked towards meeting or using those metrics in the winter and the spring as opposed to the late winter and spring.

## **Chapter 10**

# **Acknowledgements**

The authors would like to thank the Santa Clara University School of Engineering for funding us. We also acknowledge the contributions of Dr. Iris Stewart-Frey and her research team, Sean Lanthier, Yohannes Kahsai, Nicholas Mikstas, Immanuel Amirtharaj, and the Frugal Innovation Hub. The work accomplished in this project would not have been possible without you.

# Bibliography

- [1] Ho, Wee Peng. *What is PM2.5 and Why You Should Care* Retrieved from <https://blissair.com/what-is-pm-2-5.htm>
- [2] “AEROTRAK Handheld Particle Counter 9303.” TSI, Inc, [www.tsi.com/aerotrak-handheld-particle-counter-9303/](http://www.tsi.com/aerotrak-handheld-particle-counter-9303/).
- [3] “Most Advanced Air Quality Sensor — Know Your Air With UHoo.” UHoo, [uhooair.com/](http://uhooair.com/).
- [4] Speck™, [www.specksensor.com/](http://www.specksensor.com/).
- [5] “Flow, the Personal Air Quality Tracker.” Flow - The Personal Air Pollution Tracker, [flow.plumelabs.com/](http://flow.plumelabs.com/).
- [6] <https://www.mouser.com/applications/energy-harvesting-new-applications/>
- [7] Kulkarni, P., & Sudevalayam, S. (2011). Energy Harvesting Sensor Nodes: Survey and Implications. *IEEE Communications Surveys and Tutorials*, 13, 443-461.
- [8] P. Kreczanik, P. Venet, A. Hijazi and G. Clerc, “Study of Supercapacitor Aging and Lifetime Estimation According to Voltage, Temperature, and RMS Current,” in *IEEE Transactions on Industrial Electronics*, vol. 61, no. 9, pp. 4895-4902, Sept. 2014. doi: 10.1109/TIE.2013.2293695
- [9] Brugha, Rossa, and Jonathan Grigg. “Urban Air Pollution and Respiratory Infections.” *Paediatric Respiratory Reviews*, vol. 15, no. 2, June 2014, pp. 194–199.
- [10] “Engineering Handbook.” School of Engineering, Santa Clara University, <https://sites.google.com/a/scu.edu/soe-intranet/current-undergraduate-students/engineering-handbook>
- [11] “IEEE Code of Ethics.” IEEE - Advancing Technology for Humanity, Institute of Electrical and Electronics Engineers, [www.ieee.org/about/corporate/governance/p7-8.html](http://www.ieee.org/about/corporate/governance/p7-8.html).
- [12] Scutti, Susan. “1 In 6 Global Deaths Link to Pollution, Study Says.” CNN, Cable News Network, 20 Oct. 2017, [www.cnn.com/2017/10/19/health/pollution-1-in-6-deaths-study/index.html](http://www.cnn.com/2017/10/19/health/pollution-1-in-6-deaths-study/index.html).
- [13] Velasquez, Manuel, et al. “A Framework for Ethical Decision Making.” *Ethical Decision Making - Markkula Center for Applied Ethics*, Markkula Center for Applied Ethics, [www.scu.edu/ethics/ethics-resources/ethical-decision-making/](http://www.scu.edu/ethics/ethics-resources/ethical-decision-making/).
- [14] Sponsored by SGX Sensortech (IS) Ltd. “Introduction to Gas Sensing Using Non-Dispersive Infrared (NDIR).” AZoSensors.com, 27 July 2017, [www.azosensors.com/article.aspx?ArticleID=544](http://www.azosensors.com/article.aspx?ArticleID=544).
- [15] “Understanding Air Pollution and the Way It Is Measured.” World Bank, [www.worldbank.org/en/news/feature/2015/07/14/understanding-air-pollution-and-the-way-it-is-measured](http://www.worldbank.org/en/news/feature/2015/07/14/understanding-air-pollution-and-the-way-it-is-measured).
- [16] “WHO Releases Country Estimates on Air Pollution Exposure and Health Impact.” World Health Organization, World Health Organization, [www.who.int/en/news-room/detail/27-09-2016-who-releases-country-estimates-on-air-pollution-exposure-and-health-impact](http://www.who.int/en/news-room/detail/27-09-2016-who-releases-country-estimates-on-air-pollution-exposure-and-health-impact).
- [17] “Air Pollution Accounts for 1 in 8 Deaths Worldwide, According to New WHO Estimates.” National Institute of Environmental Health Sciences, U.S. Department of Health and Human Services.