Electronic Thesis and Dissertation Repository

5-14-2019 2:00 PM

The Role of Cognitive Distortions in the Longitudinal Relationship Between Problematic Drinking and Depressive Symptoms

Monica F. Tomlinson
The University of Western Ontario

Supervisor
Dozois, David J. A.
The University of Western Ontario

Graduate Program in Psychology
A thesis submitted in partial fulfillment of the requirements for the degree in Doctor of Philosophy
© Monica F. Tomlinson 2019

Follow this and additional works at: <https://ir.lib.uwo.ca/etd>



Part of the [Clinical Psychology Commons](#)

Recommended Citation

Tomlinson, Monica F., "The Role of Cognitive Distortions in the Longitudinal Relationship Between Problematic Drinking and Depressive Symptoms" (2019). *Electronic Thesis and Dissertation Repository*. 6197.

<https://ir.lib.uwo.ca/etd/6197>

This Dissertation/Thesis is brought to you for free and open access by Scholarship@Western. It has been accepted for inclusion in Electronic Thesis and Dissertation Repository by an authorized administrator of Scholarship@Western. For more information, please contact wlsadmin@uwo.ca.

Abstract

This dissertation investigated the mechanisms by which problematic drinking contributes to depressive symptoms in two longitudinal, prospective, cohort-design studies. Distorted cognitive processes (dysfunctional attitudes, negatively-biased information processing, and rumination) were proposed as mediators in the relationship between problematic drinking and depressive symptoms over time. Study 1 ($N = 1090$) assessed participants' levels of problematic drinking, dysfunctional attitudes, and depressive symptoms at three-month intervals for one year. Findings indicated that the social and occupational consequences of alcohol use (e.g., interpersonal conflict) significantly predicted depressive symptoms. The amount and frequency of alcohol consumption did not. Therefore, impairment, but not level of consumption, is predictive of psychopathology in the long-term. Longitudinal analyses found inconsistent evidence that dysfunctional attitudes mediated this relationship over time. Study 2 ($N = 321$) incorporated measures of ruminative thinking, biased information processing, and motivations behind drinking (e.g., drinking to cope), 8-12 weeks apart. There was no evidence of a significant predictive relationship between alcohol problems and depressive symptoms in this time frame. Rather, a third-variable relationship emerged, whereby cognitive variables predicted changes in both alcohol problems and depressive symptoms. Specifically, "drinking to cope" predicted drinking problems, negatively-biased information processing predicted both depressive symptoms and alcohol problems, and dysfunctional attitudes predicted depressive symptoms over time. Clinicians treating individuals with this comorbidity are encouraged to focus on and address the underlying distorted cognitive processes that contribute to the social and occupational consequences of their clients' drinking patterns and help them actively manage their clinical impairment through cognitively-focused interventions.

Keywords

Depression, alcohol, alcohol use disorders, major depressive disorder, concurrent disorders, dysfunctional attitudes, rumination, negative information processing bias, mediation model, structural equation model.

Acknowledgments

First and foremost, I owe a debt of gratitude to my family. Mom, dad, Isaac - you mean the world to me. Aunt Fran, Grandma, all of my wonderful extended family - you have all supported me and kept me grounded in my values from the beginning. You have taught me to think critically, feel fully, weather storms, and push myself far beyond my comfort zone.

David, you are a true mentor. You are so deeply invested in the success and well-being of all of your students and I am so grateful for your guidance, dedication, and encouragement. I also thank you for bringing together such a wonderful group of graduate students. Katerina, Jesse, Lindsay, Jennifer, Dan, you have been such a pleasure to work with and I have no doubt that you will all take the clinical psychology world by storm.

To all of my friends, you have made London feel like a home over the last six years. I will look back fondly on our Trivia Nights (Go Cheese Quiz on Toast!), Board Game nights, and trips to wine country. I couldn't have made it through without your support.

Josh - your dedication, drive, and unwavering self-motivation kept me on track over the last four years. You encouraged me to think more deeply, helped me learn new statistical softwares, walked me through complex analyses, and supported (or at least tolerated) all of the foster dogs, tenants, home renos, and additional clinical work that I took on. I look forward to joining you out West in the coming months for my residency year.

I owe a debt of gratitude to my thesis advisory committee members. Dr. Paul Tremblay, I honestly could not have pulled this dissertation together without your unending statistical guidance. You deserve a barrel of home-made pickles. Dr. Nick Kuiper, thank you for your thoughtful suggestions throughout this process. A tremendous thank you to Drs. Nick Kuiper, Robert Mann, Riley Hinson, Tara Dumas, and Paul Tremblay for contributing to my departmental and senate oral defenses.

Table of Contents

Abstract.....	i
Acknowledgments.....	iii
Table of Contents	iv
List of Figures	xi
List of Tables	xiv
List of Appendices	xv
Chapter 1.....	1
1 Introduction.....	1
1.1 The Three Possible Relationships Between Alcohol Problems and Depressive Symptoms	3
1.1.1 An Indirect Relationship.....	3
1.1.2 A Causal Relationship.....	6
1.1.2.1 Depressive Symptoms Cause Alcohol Problems	6
1.1.2.2 Alcohol Problems Cause Depressive Symptoms	10
1.1.2.3 The Physiological Effects of Alcohol on Depression	11
1.1.2.4 The Cognitive Effects of Alcohol Problems on Depressive Symptoms.	15
1.1.2.5 Alcohol, Depression, and Cognitive Deficits.	16
1.1.3 Alcohol, Depression, and Cognitive Distortions (e.g., Dysfunctional Attitudes, Ruminative Thinking, and Information Processing biases).....	18
1.1.4 A Reciprocal Relationship.	23
1.1.5 Gaps in the Literature.....	26

1.1.6	Importance of the Present Research.....	28
Chapter 2	30
2	Study One: The Community Study.....	30
2.1	Design.....	30
2.1.1	Time Interval Considerations.....	30
2.2	Sample Size.....	33
2.3	Sample.....	34
2.4	Measures.....	37
2.4.1	Demographic Information.....	37
2.4.2	Alcohol Use Measures.....	37
2.4.3	Mood Measures.....	39
2.4.4	Measures of Distorted Cognitive Processes.....	39
2.4.5	Sad Mood Induction.....	40
2.4.6	Attention Checks.....	41
2.5	Procedure.....	42
2.6	Hypotheses.....	44
2.6.1	Cross-Sectional Hypotheses.....	44
2.6.1.1	Mediation Hypotheses.....	45
2.6.1.2	Moderated Mediation Hypotheses.....	45
2.6.2	Longitudinal Hypotheses.....	45
2.6.2.1	Mediation Hypotheses.....	45
2.6.3	Moderated Mediation Hypotheses.....	46
2.7	Analyses for the Community Study.....	46
2.7.1	Confirmatory Factor Analyses of the Measures.....	47

2.8	Data Analytic Techniques for Community Sample	48
2.8.1	SPSS Analyses	48
2.8.2	MPlus Analyses	48
Chapter 3	50
3	Results.....	50
3.1.1	Attrition.....	50
3.1.2	Correlations Between All Variables at Time 1	51
3.1.3	Correlations Between Variables at Different Time Points	52
3.1.4	Prevalence of “Clinical” Levels of Depressive Symptoms and Alcohol Use.....	53
3.1.5	Variability in Alcohol Problems, Dysfunctional Attitudes, and Depressive Symptoms over One Year	53
3.2	Cross-Sectional Analyses.....	54
3.2.1	The Measurement Model	56
3.2.2	The Structural Equation Models	58
3.2.2.1	Cross-Sectional Moderated Mediation	59
3.3	Longitudinal Analyses	61
3.3.1	Results for the Path Model from AUDIT to BDI-II	61
3.3.2	Moderated Mediation Analyses	62
3.3.2.1	Women.....	62
3.3.2.2	Men	63
3.3.3	AUDIT Subscales	64
3.4	Results for the Path Model from RAPI to BDI-II.....	64
3.4.1	Moderated Mediation Analyses	66
3.4.2	Results from RAPI Subscales	66

3.4.2.1	RAPI Social/Occupational Consequences	66
3.4.3	Moderated Mediation Analyses with RAPI, Social/Occupational Consequences Subscale	68
3.4.3.1	RAPI Withdrawal-Dependence	70
3.4.4	Moderated Mediation Analyses with RAPI, Alcohol Dependence and Withdrawal.....	72
Chapter 4	73
4	Conclusions from the Community Study.....	73
Chapter 5	77
5	Testing Alternative Models: The Self-Medication Hypothesis	77
5.1	Results for the Path Model from BDI-II to AUDIT	77
5.2	Alternative Model from BDI-II to RAPI	79
5.2.1	Results for the Path Model from BDI-II to RAPI.....	79
5.2.2	Summary of Findings from the Alternative Model from BDI-II to RAPI.....	80
Chapter 6	82
6	Conclusions from the Alternative Model.....	82
Chapter 7	84
7	Study Two: The Student Study	84
7.1	Cross-sectional Hypotheses	86
7.2	Longitudinal Hypotheses	86
7.3	Methods.....	87
7.3.1	Design	87

7.3.2	Sample.....	88
7.3.3	Measures	91
7.3.3.1	Additional Cognitive Measures	91
7.3.4	Scoring the Self-Referent Encoding Task.....	94
7.3.5	Procedure	96
7.3.6	Missing Data	97
7.3.7	Data Analytic Techniques for Community Sample	98
7.3.7.1	SPSS Analyses	98
7.3.8	MPlus Analyses	98
7.3.9	Data Cleaning and Analysis	99
Chapter 8.....		100
8	Results of the Student Study	100
8.1	Descriptive Statistics.....	100
8.1.1	Variability in Alcohol Problems, Dysfunctional Attitudes, and Depressive Symptoms Over One Year	101
8.2	Correlations Between Primary Variables at Time 1	102
8.2.1	CFA of the Measurement Model	104
8.2.2	Cross-Sectional Structural Equation Model, Time 1.	105
8.2.3	Moderated Mediation Cross-Sectional Analyses	107
8.2.3.1	Women.....	107
8.2.3.2	Men	107
8.3	Longitudinal Analyses	108
8.3.1	General Longitudinal Model.....	109
8.3.2	Mediational Longitudinal Model	110

8.3.2.1	Path from the Social and Occupational Consequences of Alcohol to the Cognitive Symptoms of Depression, Through Dysfunctional Attitudes	111
8.3.2.2	Moderated Mediation Analyses, Dysfunctional Attitudes	112
8.3.2.3	Path from the RAPI, Social and Occupational Consequences Subscales to BDI, Cognitive Subscale, Through Negatively-biased Information Processing	114
8.3.2.4	Moderated Mediation Analyses with Negatively-biased Information Processing	115
8.4	Alternative Longitudinal Models: From Depression to Alcohol Problems	116
8.4.1	General Longitudinal Model.....	116
8.4.2	Mediational Longitudinal Alternative Model	118
8.4.2.1	Path from the RAPI, Social and Occupational Consequences Subscales to BDI, Cognitive Subscale, Through DAS	118
8.4.2.2	Moderated Mediation Analyses, Dysfunctional Attitudes	119
8.4.2.3	Path from BDI, Cognitive Subscale, to RAPI, Social and Occupational Consequences Subscales Through Negatively-biased Information Processing.....	121
8.4.2.4	Moderated Mediation Analyses with Negatively-biased Information Processing	122
8.5	Third Variable Hypothesis.....	123
Chapter 9	124
9	Student Study Part 2: Drinking Motives	124
9.1.1	SEM with Drinking Motives, Alcohol Problems, Distorted Cognitive Processes, Depression.....	125
9.1.2	Longitudinal SEM with Coping Motives, Alcohol Problems, Dysfunctional Attitudes, and Depressive Symptoms	126

9.1.3 Longitudinal SEM with Coping Motives, Alcohol Problems, Negatively-biased Information Processing, and Depressive Symptoms	127
Chapter 10.....	129
10 One Final Model	129
Chapter 11	131
11 Conclusions for the Student Study.....	131
Chapter 12.....	134
12 General Discussion	134
References.....	155
Appendices.....	186
Curriculum Vitae	233

List of Figures

Figure 1. A theoretical model of the relationship between alcohol use and depression.	25
Figure 2. Full longitudinal mediation model of the relationship between alcohol use, dysfunctional attitudes, and depressive symptoms at three-month intervals.	32
Figure 3: Longitudinal mediation model at six-month intervals.	33
Figure 4. The final measurement model for the community sample, time 1 data used.	57
Figure 5. Cross-sectional structural equation model time 1 (standardized coefficients).	59
Figure 6. Longitudinal path model from alcohol use disorder symptoms (AUDIT) to depressive symptoms (standardized coefficients), six-month paths.	62
Figure 7. Cross-lagged paths alcohol use disorder symptoms (AUDIT) to depressive symptoms for women.	63
Figure 8. Longitudinal path models from alcohol problems (RAPI) to depressive symptoms (standardized coefficients).	65
Figure 9. Cross-lagged paths from alcohol problems (social/occupational consequences subscale) to depressive symptoms, three-month and six-month paths.	67
Figure 10. Cross-lagged paths from alcohol problems (social/occupational consequences subscale) to depressive symptoms, six-month paths for men.	69
Figure 11. Cross-lagged paths from alcohol problems (withdrawal-dependence subscale) to depressive symptoms, three-month and six-month paths.	71
Figure 12. Alternative models from depression to alcohol use disorder symptoms, three- month and six-month paths.	78
Figure 13. Alternative models from depressive symptoms to alcohol problems, three-month and six-month paths.	80

Figure 14. The two possible mediation pathways for the student sample longitudinal analyses.	88
Figure 15. Final cross-sectional measurement model for the student study, time 1 data used.	104
Figure 16. Cross-sectional SEM model for student study, time 1.	106
Figure 17. Student sample, from the social and occupational consequences of alcohol use to the cognitive symptoms of depression, through dysfunctional attitudes.	112
Figure 18. Moderated mediation analyses, alcohol problems to depression through dysfunctional attitudes	113
Figure 19. Student sample, from the social and occupational consequences of alcohol use to the cognitive symptoms of depression, through negatively-biased information processing.	114
Figure 20. Moderated mediation analyses, alcohol problems to depression through negatively-biased information processing.	115
Figure 21. Student sample, from the cognitive symptoms of depression to the social and occupational consequences of alcohol use, through dysfunctional attitudes.	119
Figure 22. Moderated mediation analyses, depressive symptoms to alcohol problems through dysfunctional attitudes.	120
Figure 23. Student sample, from the cognitive symptoms of depression to the social and occupational consequences of alcohol use, through negatively-biased information processing.	122
Figure 24. Moderated mediation analyses, depression to alcohol problems through negatively-biased information processing.	123
Figure 25. SEM with drinking to cope, alcohol problems, dysfunctional attitudes, and depressive symptoms (Time 1).	126

Figure 26. Longitudinal model from drinking to cope to depressive symptoms.	128
Figure 27. The third variable hypothesis supported, distorted cognitive processes and drinking motivations predict alcohol problems and depression over time.	130
Figure 28. Cross-sectional SEM, time 2.	210
Figure 29. Cross-sectional SEM, time 3.	211
Figure 30. Cross-sectional SEM, time 4.	212
Figure 31. Cross-sectional SEM, time 5.	212
Figure 32. Cross-sectional CFA with alcohol problems, coping motives, and depressive symptoms (time 1).	232

List of Tables

Table 1. Demographic Statistics for the Community Sample.....	35
Table 2. Descriptive Statistics of Time 1 Community Data	47
Table 3. Correlations Between All Variables at Time 1, Community Study	55
Table 4. Correlation Matrix for all Variables in the Measurement Model of Time 1 Community Sample Data	58
Table 5. Demographic Statistics for the Student Sample	90
Table 6. Scores on the Self-Referent Encoding Task, Time 1 and 2	95
Table 7. Descriptive Statistics of Time 1 Student Data	100
Table 8. Correlations Between Primary Variables at Time 1, Student Study.....	103
Table 9. Correlation Table for Measurement Model, Student Study, Time 1 Data Used	105
Table 10. Correlations Between Variables Across Time Points.	206
Table 11. AUDIT, RAPI, DAS, and BDI-II Scores Across One Year, By Sex (Community Study).....	209
Table 12. AUDIT, RAPI, DAS, and BDI-II Scores Across Three Months, By Sex (Student Study).....	223
Table 13. Correlations Between Primary Variables and Secondary Variables at Time 1, Student Study	230
Table 14. Correlations Between Secondary Variables at Time 1, Student Study.....	231

List of Appendices

Appendix A: Letters of Information and Consent and Debriefing Forms	186
Appendix B: Data Cleaning and Analysis of Measures for Community Study	196
Appendix C: Confirmatory Factor Analyses of the Measures (Community Data)	203
Appendix D: Additional Descriptive Data.....	206
Appendix E: Cross-Sectional Analyses for Time Points 2-5.....	210
Appendix F: Longitudinal Findings from the AUDIT Subscales (Community Study).....	214
Appendix G: Data Cleaning and Analysis of Measures for Student Study	220
Appendix H: A Description of How Variables Were Associated with Each Other in the Student Study and Changes in Variables over Time	224
Appendix I: The CFA of Alcohol Problems, Coping Motives, and Depressive Symptoms, Student Study	232

Chapter 1

1 Introduction

Major depressive disorder (MDD) is a prevalent mental disorder and one of the leading causes of disability worldwide (Gotlib & Hammen, 2014). A diagnosis of MDD also confers a three-fold increased chance of having a comorbid alcohol use disorder (AUD; Lukassen & Beaudet, 2005). Recent estimates suggest that one in 10 Canadians will develop MDD, one in five will develop AUD (Pearson, Janz, & Ali, 2013), and one in 13 will experience a co-occurrence of these disorders in their lifetime (Brière, Rohde, Seeley, Klein, & Lewinsohn, 2014). Studies examining how alcohol use impacts the course of MDD over a two year period have shown that individuals with remitted or current alcohol dependence¹ have more severe depressive symptoms compared to individuals with no history of alcohol dependence (Boschloo et al., 2011, 2012). Further, 95% of individuals with both diagnoses continue to experience depressive symptoms over the course of two years, compared to 53% of individuals with MDD alone (Brière et al., 2014). Moreover, comorbid MDD and AUD has been persistently associated with a higher frequency of self-harm, a higher likelihood of completing suicide, lower global functioning, poorer economic productivity, and lower life satisfaction than having MDD (Boden & Fergusson, 2011; Boschloo et al., 2012; Brière et al., 2014) or AUD independently (Archie, Zangeneh Kazemi, & Akhtar-Danesh, 2012; Crum et al., 2013).

¹ based on diagnoses from the 4th edition of the *Diagnostic and Statistical Manual of Mental Disorders* (American Psychiatric Association [APA], 2000).

Thus, comorbid AUD not only worsens the severity and course of MDD, but also leads to poorer functioning and higher risk for mortality than exhibiting either disorder alone.

The significant negative outcomes associated with these disorders warrants a more detailed study of their relationship (Davis, Uezato, Newell, & Frazier, 2008). The four objectives of this dissertation are to; (1) unpack the complex relationship between problematic drinking patterns and depressive symptoms by providing an overview of the research investigating the relationships between these two symptom profiles; (2) synthesize this literature into a comprehensive theoretical model; (3) identify the current empirical gaps in this model; and (4) conduct two studies to help address those gaps.

It is important to note that the measures used, definitions presented, and terminology employed for these two disorders have varied greatly over the last several decades, which may partially account for the heterogeneity in findings across studies. Further, a large proportion of studies do not use clinical samples, but rather assesses clinical symptoms among community or student samples. Previous research has shown that these findings can be meaningfully interpreted and generalized to clinical populations (Vredenburg, Flett, & Krames, 1993). When possible, this review focuses on AUD and MDD as defined by the most recent, 5th edition, of the *Diagnostic and Statistical Manual* (APA, 2013). In this manual, AUD is defined as “a problematic pattern of alcohol use leading to clinically significant impairment or distress” (APA, 2013, p. 490) over a 12-month period. MDD is defined as depressed mood or loss of interest or pleasure most of the day, nearly every day, for at least a two-week period, that is markedly different from previous functioning (APA, 2013). To accomplish the first objective of this dissertation, the following sections review the potential relationship

between alcohol use, alcohol problems, and depressive symptoms, and highlight which aspects of this relationship require further investigation.

1.1 The Three Possible Relationships Between Alcohol Problems and Depressive Symptoms

Three possible relationships may exist between alcohol problems and depressive symptoms; that depressive symptoms and drinking problems are related via; (1) an indirect relationship; (2) a causal relationship; (3) or a reciprocal relationship, whereby the two disorders feed into each other in a cyclical fashion. The majority of research evidence supports the theory that alcohol problems and depressive symptoms are causally linked, and that they are influenced by an interaction of genetic, environmental, physiological, and cognitive factors. Whether alcohol problems lead to depressive symptoms, or whether depressive symptoms lead to alcohol problems has been disputed over the last several decades. Several studies have also found compelling evidence that alcohol problems and depressive symptoms are related indirectly or reciprocally. Thus, to thoroughly understand the relationship between these symptom clusters, it is useful to investigate each of these three relationships in turn and to evaluate the available evidence.

1.1.1 An Indirect Relationship

Alcohol problems and depressive symptoms may be associated exclusively through third variable factors. For example, it is conceivable that genetic variables underlying both syndromes could explain the high prevalence of this comorbidity (Foo et al., 2018). Studies involving male, female, and mixed twin pairs have found that genetic factors account for 61% of the association between MDD and AUD among men and 51% of the association among women; after statistically controlling for environmental factors and

individual-specific sources of variation (Prescott, Aggen, & Kendler, 2000). To help explain these findings, several studies have attempted to locate specific genes that might be responsible for the development of both disorders. Studies have found evidence that individuals who go on to develop comorbid AUD and MDD have similar polymorphisms on the gene encoding the muscarinic acetylcholine receptor M2 (CHRM2), a gene related to the expression of certain mood-regulating neurotransmitters (J. C. Wang et al., 2004). However, this genetic polymorphism was also found among individuals who had either disorder in isolation. Therefore, there is little evidence for a gene that confers an increased vulnerability to this comorbidity, but rather evidence that some polymorphisms may be related to overall psychopathology.

It is also possible that individuals who experience more stressful life events, adverse childhood experiences, or more psychopathology overall could be at greater risk for developing comorbid AUD and MDD than individuals without those experiences. Studies investigating this possibility have found some evidence that adverse childhood experiences confer an increased probability of developing either MDD or AUD, but little evidence that these experiences contribute to an increased chance of developing the disorders comorbidly. Importantly, having a parent with AUD is not, in and of itself, a negative childhood experience, and has not been found to increase the chances that a child will later develop MDD (Anda et al., 2002). However, having a parent with an AUD does confer an increased likelihood of having an AUD later in life, regardless of childhood experiences (Anda et al., 2002).

Emerging research has investigated the potential role of cognitive distortions in the etiology and maintenance of AUD and MDD. Cognitive theories of depression have

consistently implicated cognitive distortions, defined as negatively-biased thinking patterns, as a risk factor for the development, maintenance, and relapse of depression (Beck & Bredemeier, 2016). Studies investigating the relationship among AUD, MDD, and cognitive distortions have generally found that cognitive distortions have an independent association with both AUD and MDD (Beck & Bredemeier, 2016; Caselli, Bortolai, Leoni, Rovetto, & Spada, 2008; Gjestad, Franck, Hagtvet, & Haver, 2011; Willem, Bijttebier, Claes, Vanhalst, & Raes, 2014).

When cognitive distortions were assessed in the context of individuals with both drinking problems and depressive symptoms, the findings were mixed. Although some researchers indicated that cognitive distortions predicted subsequent alcohol consumption (Gjestad et al., 2011), others suggested that alcohol consumption predicted cognitive distortions (Willem et al., 2014). Some researchers found that depression predicted cognitive distortions (Kempton, Van Hasselt, Bukstein, & Null, 1994). Researchers have also found that individuals with comorbid substance use disorders have higher levels of cognitive distortions, compared to individuals with MDD alone (Chabon & Robins, 1986) and others found that comorbid substance abuse is associated with lower levels of cognitive distortions (Kempton et al., 1994). To be sure, measures of cognitive distortions, depression, and substance use varied across studies, which may account for some of the variation in findings. Time frames investigating these relationships also varied considerably, which may have precluded a consistent pattern of findings in this area. Given that distorted cognitive processes are undisputedly related to both disorders, and that interventions (e.g., cognitive-behavioural therapies) for both disorders often involve addressing distorted cognitive processes (e.g., ruminative thinking, irrational

beliefs, dysfunctional attitudes, negatively-biased information processing), this dissertation will explore how cognitive variables interact with depressive symptoms and alcohol problems, and whether they present as a potential third-variable to explain the development and maintenance of both symptom profiles, or whether they have a mediating role in the relationship between these two disorders.

Taken together, there is insufficient evidence that the comorbidity of these disorders is caused by third variable environmental factors, and some empirical evidence that this comorbidity has a genetic basis (although data have failed to demonstrate that comorbidity is inherited at a higher rate than each disorder in isolation). Importantly, there is evidence for a relationship between alcohol problems and depressive symptoms after controlling for the shared genetic influences underlying both (Kuo, Gardner, Kendler, & Prescott, 2006), which indicates that, even if there are common underlying genetic factors relating to both disorders, factors beyond genes influence this relationship. There is some evidence that cognitive distortions contribute to both disorders and could present as a third variable factor causing both; however, there is insufficient data to support this hypothesis at present. As a result, research has turned its focus to investigating the possibility of a causal relationship between alcohol problems and depressive symptoms.

1.1.2 A Causal Relationship

1.1.2.1 Depressive Symptoms Cause Alcohol Problems

Proponents of the theory that depressive symptoms cause alcohol problems suggest that individuals who suffer from depression engage in drinking behaviours as a means of assuaging their symptoms or “self-medicating” (Crum et al., 2013; Dixit & Crum, 2000;

K. L. Tomlinson, Tate, Anderson, McCarthy, & Brown, 2006). There are two pillars to the Self-Medication theory: first, that individuals will engage in substance use with the purpose of alleviating their psychiatric symptomatology and, second, that symptomatology will improve following substance use, which would then positively reinforce the substance use, leading to a substance use disorder. Studies assessing the first component of this theory have shown that individuals with MDD report experiencing significant psychiatric symptoms prior to engaging in heavy substance use (K. L. Tomlinson et al., 2006), many with the expectation of alleviating (Weiss, Griffin, & Mirin, 1992), or coping with, their symptoms (Kuntsche, Knibbe, Gmel, & Engels, 2006).

In further support of the first pillar, recent data show that, among adolescent girls, MDD modestly predicts future drinking from ages 13 to 17 (Schleider et al., 2019). MDD symptoms in adulthood also exacerbate future heavy drinking, especially among women (Dixit & Crum, 2000). Among individuals with lifetime cumulative comorbidity (those who develop both disorders, but not concurrently), 57% experienced MDD first and only 41% experienced AUD first (Brière et al., 2014). Especially among women, MDD appears to confer an increased probability of developing AUD.

Importantly, however, studies prospectively assessing concurrent episodes found that AUD symptoms preceded and exacerbated the onset of MDD in 57% of cases, whereas MDD preceded AUD 23% of cases and both disorders appeared simultaneously in 20% of concurrent episodes (Brière et al., 2014). Further, there is strong evidence that AUD predicts the course and severity of MDD better than MDD predicts the course and severity of AUD (Boschloo et al., 2012; Carton et al., 2018; Kenneson, Funderburk, & Maisto, 2013). Prospective studies using structural equation modeling to determine causal

pathways between AUD and MDD, have found further support for a reverse causality, whereby AUD causes MDD, regardless of gender (Boden & Fergusson, 2011; Fergusson, Boden, & Horwood, 2009).

In a recent study assessing alcohol problems and depressive symptoms over four years among men, problematic alcohol use predicted depressive symptoms better than depressive symptoms predicted alcohol use (Lee, Chung, Lee, & Seo, 2018). Further, problem drinking intensified the symptoms of depression across all four years of analysis (Lee et al., 2018). Boden and Fergusson (2011), after assessing all possible relationships between these two disorders conclude that, “the most plausible causal association between AUD and MDD is one in which AUD increases the risk of MDD” (p. 106). Therefore, there is insufficient empirical support for the first pillar of the Self-Medication Hypothesis and increasing evidence for the contrary.

The second pillar of this hypothesis also lacks consistent empirical support. Rather than finding a relationship between increased alcohol use and decreased psychiatric symptoms, studies have found that 68% of individuals who engage in alcohol use to attenuate their depressive symptoms experience more severe depressive symptoms and lower global functioning immediately after substance use and 72% experience more severe and prolonged symptoms two weeks after substance use (K. L. Tomlinson et al., 2006) and one year later (Bellos et al., 2016). There may be some age differences in this effect, however, as there is evidence among adolescents that frequent, light or moderate, drinking can decrease or prevent symptoms of depression from 13 to 17 years old, especially if drinking is occurring in social situations (Schleider et al., 2019). Thus, light and moderate drinking in adolescence may be an indicator of socially normative

adolescent behaviour, which may be associated with more psychological health (Schleider et al., 2019). Among adults, however, there is little evidence to support the theory that alcohol use causes positive affect over time (Bellos et al., 2016).

To help shed light on these seemingly counterintuitive findings, it is useful to briefly discuss the physiological properties of alcohol use. Alcohol is a complex substance that produces stimulating effects during absorption (during intoxication) and depressant effects during elimination (after intoxication). In most studies, participants are interviewed during the elimination phase, which would physiologically produce depressed affect. In support of this assertion, all participants in the above-mentioned study self-reported more severe and prolonged symptoms of depression immediately after alcohol use and in the two weeks following alcohol use compared to individuals who did not consume alcohol (K. L. Tomlinson et al., 2006). It is possible that more support for the second pillar of the Self-Medication Hypothesis would surface if participants were interviewed during intoxication. Indeed, a study that examined individuals' self-referent encoding of negative information found that individuals with depression encoded less negative-self-referent information when they were acutely intoxicated compared to when they were given a placebo drink that participants thought was alcoholic (Stephens & Curtin, 1995). Studies investigating the amount of time that individuals spend intoxicated, and monitoring depressive symptoms during those periods of intoxication, are needed to determine whether depressive symptoms are attenuated during intoxication, and are only exacerbated during elimination. Given the propensity of individuals with AUD to use avoidance coping as a means of tolerating unpleasant emotions and managing life stressors, it is also possible that individuals are consuming alcohol, not as a

way to “feel better”, but as a way not to feel, to forget their feelings, or to escape the realities of their emotions and the events around them (Cowan, 1983; Dickter, Forestell, Hammett, & Young, 2014; Forestell, Dickter, & Young, 2012).

Overall, there is little evidence that depression causes alcohol use, or that alcohol use improves symptoms of depression over time. It is much more likely that individuals who struggle with alcohol-related problems are using alcohol as more of an avoidance coping mechanism than a means of self-medication with hopes of improving their symptoms. Nevertheless, it is possible that some individuals self-medicate using alcohol, and that individuals who are depressed and who lack other means by which to cope will continue to self-medicate with alcohol as a means of avoidance coping despite the negative long-term consequences (Cowan, 1983). This behaviour may lead to a feedback loop, whereby alcohol is used to alleviate low mood or numb, successfully alleviates low mood (and/or helps individuals avoid and distract from current problems) during acute intoxication, exacerbates low mood during elimination, and consequently maintains or worsens the overall depressive syndrome. This possibility is further explored in the section entitled *Reciprocal Relationship*.

1.1.2.2 Alcohol Problems Cause Depressive Symptoms

Data suggest that changes in alcohol consumption vary with changes in depressive symptoms, and are more predictive of changes in depressive symptoms than depressive symptoms are of alcohol problems (Gjestad et al., 2011). The following section offers an overview of the physiological and cognitive effects of alcohol on depressive symptomatology to help provide a theoretical and empirical foundation for the hypothesis

that alcohol problems causes depressive symptoms among individuals with both disorders.

1.1.2.3 The Physiological Effects of Alcohol on Depression

During acute intoxication, alcohol quickly enters the bloodstream and crosses the blood-brain barrier. Alcohol then moves into cell membranes and impacts neuronal functioning. Within neurons, alcohol affects the functioning of neurotransmitters (amino acids, peptides, and monoamines); the molecules that allow neurons to communicate. Among the amino acids, alcohol primarily influences glutamate activity. During intoxication, alcohol reduces the effectiveness of glutamate at the N-methyl-D-aspartate (NMDA) receptor. Impairment to the NMDA receptor during intoxication is associated with memory blackouts and impairments in spatial memory.

During withdrawal, lasting deficiencies in this receptor are associated with behavioural hyperactivity (Chastain, 2006). Repeated alcohol use depletes the availability of glutamate in the brain, which causes the brain to create an abundance of NMDA receptors (McCarthy et al., 2012). The consequences of alcohol-induced disruptions in this system lead to problems in learning, memory, and spatial awareness. Further, alterations in glutamatergic neurotransmission have been increasingly associated with problems in mood regulation (McCarthy et al., 2012). Specifically, phenotypic sequelae of glutamate overdose are poor concentration, irritability, memory problems, and retarded motor functioning, all of which present as symptoms of depression (McCarthy et al., 2012). Researchers have termed this relationship “glutamate-based depression”, and are increasingly suggesting that disruptions in this amino acid may underlie a considerable portion of clinically-observed depressive symptoms (Hashimoto, 2009; McCarthy et al.,

2012). Of note, drugs that target the NMDA receptor and regulate glutamate activity have been shown to produce antidepressant effects (Pittenger, Sanacora, & Krystal, 2007). These findings indicate that alcohol-induced changes to the functioning of glutamate may cause symptoms of depression among individuals who consume alcohol, especially repeatedly and in high doses.

Gamma-amino-butyric acid (GABA) is another amino acid disrupted by acute and repeated alcohol use. GABA is the brain's main inhibitory neurotransmitter. Alcohol has been found to reduce the inhibitory effects of GABA, thus further dysregulating glutamatergic neurotransmission. Specifically, alcohol has been found to reduce concentrations of GABA in the brain, which is associated with depressive symptomatology. In general, studies have found that GABA levels are lower among patients with depression compared to patients without depression (Brambilla, Perez, Barale, Schettini, & Soares, 2003). Interestingly, after prolonged alcohol use, disruptions in GABA reduce the excitatory and anti-anxiety effects of alcohol (Chastain, 2006; Cryan & Kaupmann, 2005), which may lead to increased amounts of alcohol consumption over time to obtain the desired effects.

Although research investigating the effects of amino acids in the etiology of depression is relatively new, studies investigating the monoamines, dopamine and serotonin, span several decades (Birkmayer & Riederer, 1975; Rominger et al., 2015; Willner, 1983). Dopamine is a neurotransmitter closely related to motivation and reinforcement. Acute intoxication is associated with a flood of dopamine in the brain, which partly explains the overall positive experiences associated with alcohol intoxication (Chastain, 2006), and likely contributes to repeated alcohol consumption,

especially among those who are biologically sensitive to dopamine (Blum et al., 1990). Repeated intoxication, however, is related to overall decreases in dopamine production, which causes dysphoria, reduced motor activity, and a reduced ability to derive pleasure from experiences. Further, the decreases in dopamine activity following intoxication provide some explanation for the depressant effects of alcohol during elimination (Rominger et al., 2015).

Serotonin is another monoamine critical for human functioning. Serotonin is related to the regulation of sleep, appetite, pain, mood, memory, and learning (Chastain, 2006). This monoamine has received the majority of attention in depression research, as changes in serotonin have been most consistently related to depressive symptoms (Asberg, Thoren, Traskman, Bertilsson, & Ringberger, 1976; Risch et al., 2009). Like dopamine, serotonin increases during acute intoxication and produces a pleasurable subjective experience. When serotonin decreases after the consumption of alcohol, it can cause depressive effects similar to dopamine. Further, alcohol-influenced increases in serotonin can stimulate dopamine production and, in turn, increase emotionality (Chastain, 2006). Individuals with low baseline levels of serotonin have been found to consume more alcohol and are more likely to develop alcohol-related problems compared to those who have higher baseline levels of serotonin, potentially because their body is attempting to regulate its levels of serotonin.

Data show that genetic variations in the serotonin transporter gene (which influences serotonin availability in the brain) predict whether adolescents will develop AUDs (van der Zwaluw et al., 2010) and MDD (Caspi et al., 2003; Risch et al., 2009). For example, research has demonstrated that having the 5-HTTLPR serotonin transporter

gene is related to the frequency and amount of alcohol use, as well as the severity of depressive symptoms. The short allele of 5-HTTLPR has been associated with depression, but only among adults who experience negative life events (Caspi et al., 2003). Meta-analytic data suggest that the short allele of this gene is also associated with AUD (McHugh, Hofmann, Asnaani, Sawyer, & Otto, 2010) and the long allele of this gene is associated with AUD when depressive symptoms are also present (Tartter & Ray, 2011). Thus, the long allele of the 5-HTTLPR transporter gene may confer an increased probability of developing problematic drinking patterns, which then disrupts mood regulation (regardless of environmental stressors), whereas the short allele may confer an increased susceptibility to reacting poorly to environmental stress.

To summarize, research evidence suggests that alcohol mainly disrupts glutamatergic, GABAergic, dopaminergic, and serotonergic systems by causing initial influxes of these neurotransmitters during intoxication and long-term depletions in these neurotransmitters during elimination and prolonged use. The long-term disruptions in these systems are known to impact the Hypothalamic-Pituitary-Adrenal (HPA) axis - a system designed to secrete stress hormones in reaction to stress, which allows the body to quickly respond to stressful situations in the environment. This system is also tasked with returning the body to a state of rest, or homeostasis, following a stressful event. There is evidence that individuals who consume moderate or high amounts of alcohol have more of the stress hormone, cortisol, compared to light drinkers or non-drinkers; which causes the body to have a more intense stress reaction during periods of perceived stress. Further, studies have shown that alcohol use is related to a dysregulated inhibitory HPA response, which leads to a slower return of the body to resting state following a stressful

event. When the body is in a prolonged period of high stress reactivity, it is less able to regulate its resting state functions, such as sleeping, eating, and mood regulation (Thayer, Hall, Sollers III, & Fischer, 2006). This dysregulation between arousal and resting state is known to impair cognitive, affective, and physiological processes, many of which are related to depressive symptomatology (Beck & Bredemeier, 2016).

1.1.2.4 The Cognitive Effects of Alcohol Problems on Depressive Symptoms.

The negative impact of alcohol on cognitive processes is well documented (Chabon & Robins, 1986; Giancola & Zeichner, 1997; Ritchie et al., 2014). This research has generally investigated two separate topics related to cognitive functioning: cognitive deficits and cognitive distortions. Whereas cognitive deficits involve the inability to exercise the necessary cognitive activity in situations where it would be necessary or beneficial, cognitive distortions represent distorted or biased thinking processes (Epkins, 2000). When relating these cognitive processes to alcohol and depression, there is evidence that alcohol produces cognitive deficits (Schweizer & Vogel-Sprott, 2008), and that cognitive deficits are associated with depression (Pantzar et al., 2014). There is also evidence that individuals who drink alcohol have higher levels of distorted thinking compared to individuals who do not drink alcohol (Gjestad et al., 2011). Further, there is overwhelming evidence that distorted thinking is related to depression (Beck, 1993).

Widely held cognitive theories of depression posit that negatively-biased or distorted information processing can facilitate overgeneralized negative views of the self, world, and future, which can cause depressive symptoms (Beck, 1993; Beck & Bredemeier, 2016). Interestingly, the literatures on alcohol and cognitive deficits, alcohol and cognitive distortions, depression and cognitive deficits, and depression and cognitive

distortions do not generally overlap. Thus, there has been minimal exploration of the possibility that alcohol-induced cognitive deficits contribute to the development of cognitive distortions and increase an individuals' vulnerability to MDD. The following section seeks to synthesize the research on alcohol's impact on cognitive deficits and distortions to help relate these processes to depressive symptomatology in an overarching theoretical model.

1.1.2.5 Alcohol, Depression, and Cognitive Deficits.

The literature on alcohol's effect on cognitive deficits indicates that acute and long-term alcohol use has negative effects on attention, memory, and learning. Studies investigating alcohol's impact on memory have focused largely on cognitive functions regulated by the dorsolateral prefrontal cortex and its subcortical connections such as cognitive flexibility, selective attention, inhibitory control, goal-related motivation, and working memory. For example, studies have shown that individuals under the influence of alcohol are less quick and accurate on measures of working memory, are less able to control and monitor their behaviour, and are less able to attend to relevant information in the environment and ignore irrelevant, distracting information compared to sober individuals (Schweizer & Vogel-Sprott, 2008). With regards to general memory functioning, studies have found alcohol to impair individuals' performance on long-term, but not short-term, rote verbal memory or visual memory tasks (Pantzar et al., 2014). Alcohol has also been shown to impair individuals' performance on visuospatial tasks, however these results have only been found during the elimination phase of alcohol use (Schweizer & Vogel-Sprott, 2008). The ability to attend to, retain, process, interpret, and then react to environmental stimuli is crucial for individuals' physical and mental health.

A wealth of data indicate that cognitive impairments are related to psychotic disorders, neurological disorders, and, mood disorders (Austin, Mitchell, & Goodwin, 2001). For example, meta-analytic studies have found that depression is associated with impairments in phonemic verbal fluency, sustained attention, inhibitory control, set shifting, episodic memory, and learning (Austin et al., 2001; Burt, Zembar, & Niederehe, 1995; Wagner, Müller, Helmreich, Huss, & Tadić, 2015).

It is important to note that these studies are predominantly correlational and provide little evidence that deficits in cognitive functioning *cause* depressive symptomatology. It is possible that depressive thought patterns impair individuals' cognitive processes and lead to poorer performance on neuropsychological tests. To help test this theory, studies have investigated whether neuropsychological dysfunction remits when symptoms of depression are alleviated. In general, studies testing individuals with depression on neuropsychological tasks related to attention, memory, and learning both during depressive episodes and during periods of remission find that cognitive deficits in immediate memory, delayed recall of visual and verbal information, and perceptual reasoning persist into periods of recovery (Austin et al., 2001; Paradiso, Lamberty, Garvey, & Robinson, 1997). Other studies testing individuals with depression both during episodes of depression and recovery have found persistent deficits on tasks of set shifting, verbal fluency, learning, and long-term, but not short-term, memory (Abas, Sahakian, & Levy, 1990; Sternberg & Jarvik, 1976). These findings remained significant after controlling statistically for the patients' ages, medications, and symptoms of dementia (Austin et al., 2001; Paradiso et al., 1997; Sternberg & Jarvik, 1976). Therefore, there is more empirical support for the theory that alcohol use causes cognitive impairment,

which may contribute to depressive symptomatology, rather than depressive symptomatology causing cognitive impairment.

1.1.3 Alcohol, Depression, and Cognitive Distortions (e.g., Dysfunctional Attitudes, Ruminative Thinking, and Information Processing biases).

Cognitive theories of depression have posited that negative cognitive processes emerge during stressful situations among individuals who are vulnerable to depression and instigate negative, distorted, thinking patterns that trigger feelings of depression (Beck, 2008; Beck & Bredemeier, 2016). Cognitive distortions are generally conceptualized as a systematic cognitive bias in information processing that leads individuals to selectively attend to negative aspects (and ignore positive aspects) of experiences or incoming information; thereby leading to a generally negative interpretation of the world and a generally negative memory of past experiences (Beck, 2008). This negatively-skewed information processing bias can lead individuals to develop overly negative and rigid attitudes, often referred to as *dysfunctional attitudes*, about themselves, the world, and the future. Similarly, this information processing bias can lead to *ruminative thinking*, whereby individuals repetitively and passively focus on their distress, and the possible causes and consequences of their distress, without engaging in active problem solving (Nolen-Hoeksema, 1991). The cognitive theory of depression also proposes that distorted cognitions are latent until “activated” by environmental stimuli, such as stressful life events (Beck & Bredemeier, 2016; Martin, 1990). When “activated”, these distorted cognitions can significantly impact how individuals interact with the world around them, and can cause problems in psychological, social, and occupational functioning (Beck & Bredemeier, 2016). Given

that most individuals who participate in laboratory research on depression and cognitive distortions are not actively experiencing a depressive episode, many studies use measures to activate these latent cognitive schemas. For example, studies often use negative mood induction procedures, where participants are asked to listen to sad music or are shown depressogenic statements, such as “I am useless” (Clark, 1983; Velten, 1968) to help activate latent distorted cognitions. Mood induction procedures are incorporated into the studies presented in this dissertation to help evaluate how activated distorted cognitive processes influence depressive symptoms and alcohol problems over time.

Although the literature on cognitive deficits and cognitive distortions rarely overlaps, it would seem logical that impairments in individuals’ ability to process, retain, and interpret information could lead to biased and distorted thinking when negative affect is present. Indeed, there is preliminary evidence that cognitive deficits (specifically relating to working memory, cognitive flexibility, strategic thinking, and goal-directed motivation) predict cognitive distortions relating to catastrophizing, overgeneralizing, personalizing, and selective abstraction over time (Giancola, Mezzich, Clark, & Tarter, 1999; Kirisci, Tarter, Vanyukov, Reynolds, & Habeych, 2004); although more research is needed to determine whether a causal relationship between these two processes exists. In general, the research on cognitive theories of depression has overwhelmingly focused on cognitive distortions rather than cognitive deficits. There are two major reasons for this focus; (1) cognitive distortions are more closely related to depressive symptomatology than are cognitive deficits, which are related to a wide range of psychological and social problems (Scott et al., 2015; Wagner et al., 2015) and; (2) cognitive distortions are more amenable to intervention and improvement than cognitive deficits. Thus, it is arguably

more fruitful to unpack the relationship between alcohol problems, depressive symptoms, and distorted cognitions so that these findings can be incorporated into intervention and prevention strategies by physicians, clinicians, and allied health professionals. The following studies in this dissertation focus on cognitive distortions, rather than deficits.

The literatures on AUD and MDD have largely independently discussed the role of cognitive distortions in the etiology and maintenance of each disorder. It appears that these fields of study have expanded in parallel, but have not yet been comprehensively integrated. Studies on alcohol use and cognitive distortions have found consistent evidence that dysfunctional attitudes are related to general substance use (Giancola et al., 1999; Kempton et al., 1994). Further, studies have shown that dysfunctional attitudes are higher among individuals with comorbid substance use disorders, compared to those with a psychiatric disorder (e.g., posttraumatic stress disorder, bipolar disorder, MDD) and no SUD (Kempton et al., 1994; Najavits, Gotthardt, Weiss, & Epstein, 2004).

The research on the relationship between alcohol and dysfunctional attitudes, specifically, has revealed mixed findings (Kirisci et al., 2004; Ramsey, Brown, Stuart, Burgess, & Miller, 2002). Heinz et al. (2009) found evidence that dysfunctional attitudes predicted problem drinking among college students, even after controlling for age, sex, baseline alcohol consumption, depressive symptoms, and drinking motives. Further, Ramsey and her colleagues (2002) revealed that changes in dysfunctional attitudes following cognitive-behavioural treatment for individuals with AUD and depressive symptoms predicted changes in alcohol use. However, Shoal and Giancola (2001) found no evidence that cognitive distortions predicted any substance use problems and Kirisci and his colleagues (2004) found evidence that cognitive distortions predicted later

cannabis use, but not later alcohol use. More research is needed to determine whether alcohol use contributes to the development of cognitive distortions and how these distorted cognitive processes are related to the maintenance and severity of alcohol problems over time. Promisingly, there is evidence that a vulnerability to developing AUD is associated with more cognitive distortions. For example, data show that a family history of AUD is associated with developing higher levels of dysfunctional attitudes than not having a family history of AUD (Giancola et al., 1999; Shoal & Giancola, 2001).

In addition to being associated with higher levels of dysfunctional attitudes, problematic alcohol use has also been consistently related to rumination. Studies have shown that problem drinking is associated with higher levels of rumination compared to social drinking, and that the link between rumination and problematic drinking persists after controlling for levels of depression (Caselli et al., 2008). Further, ruminative thinking patterns have been shown to differentiate between problem drinkers and social drinkers, suggesting that the presence of ruminative thinking among individuals who consume alcohol is associated with increased psychopathology (Caselli et al., 2010).

Prospective studies have found evidence that problematic alcohol use is associated with ruminative thinking patterns, including brooding and reflection. *Brooding* refers to a repetitive passive comparison of one's current situation to one's ideal and *reflection* refers to a tendency to continually think about one's current distress in an attempt to better understand and alleviate it (Willem et al., 2014). Willem and his colleagues (2014) found that alcohol use puts adolescents at risk for both brooding and reflection, after controlling for depressive symptoms. Importantly, substance use problems overall predicted both brooding and reflection in girls but not boys over time. Willem et al.

(2014) suggested that substance use problems could lead to more negative emotions, and, given that women have been found to attend more to their negative emotions than do men, they may engage in more ruminative thinking styles following substance use. These authors also posited that the increased tendency for women to engage in ruminative thinking styles could put them at an increased risk for depression. Interestingly, they also discovered that women were more stable in their drinking patterns and ruminative thinking styles over the course of a year, whereas men varied on both variables.

Information processing biases have also been consistently associated with AUD and MDD. In his well-known cognitive model of depression, Beck (1963), proposed that negatively-biased information processing distorts incoming information and maintains depressive symptomatology. Beck conjectured that individuals' who are vulnerable to depression will selectively process negative information (which is consistent with their depressive schemata) and ignore positive information. In this way, individuals vulnerable to depression should have a greater store of information that is consistent with their depressive views, which can lead to a predominately negative view of the self, world, and future – and the onset of a depressive episode.

Alcohol intoxication and prolonged alcohol use have also been repeatedly associated impairments in information processing (Hull & Reilly, 1986). As previously mentioned, information processing is compromised during intoxication compared to periods of sobriety. Data show that the encoding of verbal and visual information is poorer among intoxicated individuals compared to individuals who are sober, however the recall of verbal and visual information that is learned under sober conditions is unaffected by alcohol intoxication (Hull & Reilly, 1986). Further, alcohol appears to have

a dose-related effect on information processing, as moderate drinkers perform worse on information processing tasks than light drinkers and heavy drinkers perform worse than moderate and light drinkers (Hull & Reilly, 1986). Women are particularly susceptible to alcohol-induced impairments in information processing, likely as a result of women's lower threshold for experiencing the physiological effects of alcohol compared to men. During periods of low mood, it is highly likely that alcohol would facilitate negatively-biased information processing, especially among women, and would contribute to the onset of a depressive episode.

1.1.4 A Reciprocal Relationship.

Undoubtedly, no simple etiological explanations exist for the development of comorbid alcohol problems and depressive symptoms. The sections above offer some evidence that genetic, physiological, environmental, and cognitive factors likely contribute to this comorbidity. To help synthesize how these variables interact with each other, a theoretical model was developed (see *Figure 1*). In this model, a causal pathway is proposed whereby genetic factors contribute to abnormalities in individuals' biological stress reactivity. Such abnormalities include HPA axis dysfunction, high baseline levels of cortisol, or low baseline levels of dopamine, GABA, serotonin, and glutamate. These abnormalities can increase individuals' vulnerability to engaging in alcohol use and, during periods of low mood or stressful life events, could lead to alcohol-induced distorted cognitions, which would confer a vulnerability to developing depressive symptoms.

The literature pertaining to how these variables interact with each other suggests that some reciprocal relationships exist. For example, biological stress reactivity can be

both exacerbated by stressful life events and can increase an individuals' likelihood of perceiving events as stressful. Further, the physiological effects of alcohol can dysregulate biological stress reactivity systems and those systems could lead to increased alcohol use. Alcohol use could also contribute to distorted cognitions, which could then lead individuals to drink more as a means of coping. Lastly, depressive symptomatology could bias information processing and exacerbate or maintain cognitive distortions.

The model presented in *Figure 1* integrates the literature and proposes that alcohol use contributes to depressive symptomatology by interacting with genetic, physiological, cognitive, and environmental factors. Specifically, this model suggests that genetic and physiological factors increase an individual's susceptibility to developing an AUD, which then causes depressive symptomatology by facilitating cognitive risk factors for depression, such as dysfunctional attitudes, biased information processing, and ruminative thinking. Using this theoretical model as a foundation, the following section outlines the empirical gaps in this model and the two studies that address these gaps.

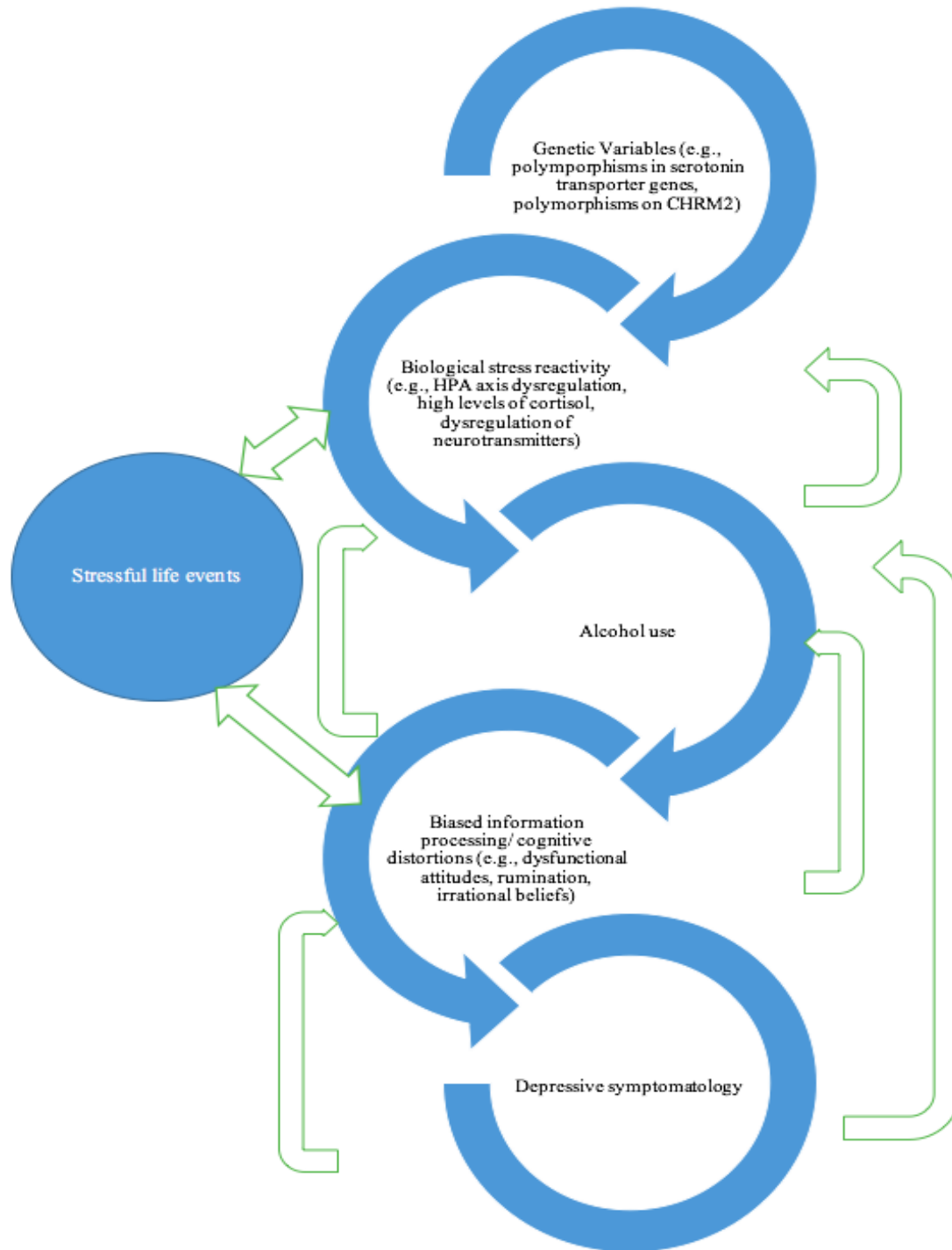

Figure 1. A theoretical model of the relationship between alcohol use and depression.

1.1.5 Gaps in the Literature

Many components of the model presented in *Figure 1* are already substantially supported by empirical data. For example, the causal relationships between genetic variables and biological stress reactivity, as well as biological stress reactivity and alcohol use are empirically well-supported (Kuo et al., 2006; Thayer et al., 2006; J. C. Wang et al., 2004). Further, there is considerable evidence that stressful life events can both impact biological stress reactivity and contribute to biased cognitive processes (Caspi et al., 2003; Risch et al., 2009). There is insufficient research, however, on the proposed causal relationship between alcohol use, distorted cognitions, and depression. Empirical data exist to link alcohol problems to distorted cognitions, distorted cognitions to depression, and depression to alcohol problems, although no studies to date have sought to unpack the causal pathways linking these three phenomena (Beck & Bredemeier, 2016; Caselli et al., 2008, 2010; Chabon & Robins, 1986). Importantly, although many studies have assessed the frequency and amount of alcohol use and its relationship to depressive symptoms (e.g., Archie et al., 2012; Bellos et al., 2016; Dixit & Crum, 2000; Holahan, Schutte, Brennan, Holahan, & Moos, 2014; Tremblay & Pulford, 2009), fewer studies have focused on *impairment* caused by problem drinking, which is far more relevant for conceptualizing the onset and maintenance of psychopathology and AUDs (APA, 2013). Therefore, this dissertation will highlight the aspects of problems drinking that lead to clinical impairment (e.g., the social and occupational consequences of alcohol use).

The literatures on AUDs and MDDs have generally focused on those who most frequently experience them. Given that women are more than twice as likely to develop

MDD than men (Nolen-Hoeksema, 1990) and adult men are twice as likely to develop an AUD compared to women (McHugh, Votaw, Sugarman, & Greenfield, 2018), the literature on MDD has focused more on women and the literature on AUD has focused more on men. However, this disproportionate disease burden of AUD in men is changing. The gap between women and men in the prevalence of AUDs is shrinking and more women are being diagnosed with AUDs each year (McHugh et al., 2018). As these literatures increasingly investigate sex differences in the relationship between AUDs and MDDs (Berger & Adesso, 1991; Cooper, Russell, Skinner, Frone, & Mudar, 1992; McHugh et al., 2018), some studies show that men are more likely to drink when they are depressed compared to women (Berger & Adesso, 1991), but that women with depression who drink exhibit more severe psychopathology than men with depression who drink (Foster et al., 2014). Cognitive variables related to both depressive symptoms and alcohol problems have generally shown that women are more susceptible to engaging in distorted cognitive processes (especially rumination) in reaction to stress compared to men, who are more likely to distract themselves from stressful situations (Nolen-Hoeksema, 1990, 2000; Nolen-Hoeksema & Harrell, 2002). No research to date has attempted to unpack sex differences in the relationship between alcohol problems, distorted cognitive processes, and depressive symptoms across time. Therefore, another gap being addressed in this dissertation is understanding sex differences in this relationship longitudinally.

Two studies were conducted to address these gaps. The first study involved a large-scale community sample, which afforded a preliminary investigation of the unsubstantiated elements of the model presented in *Figure 1*. The second study involved a student sample and provided an opportunity to replicate the findings of the first study

and expand on these findings by using more complex and time-intensive measures. Although much of the research in this area is conducted to better understand MDD and AUD, a great deal of the literature focuses on the symptoms of each, but not necessarily on the entire diagnostic profile. That is, fewer studies exclusively include individuals who have been formally diagnosed with these disorders. Rather, is common in clinical research to assess symptoms of clinical disorders (e.g., to use the Beck Depression Inventory to assess depressive symptoms) in order to make inferences about the larger diagnostic profile (Kendall, Hollon, Beck, Hammen, & Ingram, 1987). It is also common to conduct research outside of clinical populations, either with student or community samples, and to then makes inferences about clinical samples from these non-clinical samples (Vredenburg et al., 1993). The two studies in this dissertation included non-clinical samples; one community and one student sample. There is evidence that findings from non-clinical populations can offer important insight into clinical profiles (Ehring, Kleim, & Ehlers, 2011; Vredenburg et al., 1993). There has also been a call to include more non-clinical samples in this area of research (Sullivan, Fiellin, & O'Connor, 2005). First, the hypothesis that alcohol use causes depression was tested empirically. Second, the theory that this causal relationship is accounted for, partly, by the impact of alcohol on cognitive distortions was examined. Sex differences in these relationships were also evaluated.

1.1.6 Importance of the Present Research

The proposed studies seek to better understand the complex relationship between comorbid alcohol problems and depressive symptoms. Although research on each of these disorders separately abounds, limited research exists on the causal relationship

between both disorders (Davis et al., 2008; Swendsen & Merikangas, 2000). Further, research that has assessed the causal relationship between them has failed to present a compelling theoretical argument as to why one disorder might cause the other and has neglected to investigate any moderating or mediating factors influencing this relationship. A better understanding of how alcohol use and depressive symptoms are related to each other can inform treatment approaches for individuals who struggle with both alcohol-related problems and depressive symptoms. These studies may also offer more insight into how to assist individuals who are struggling at sub-threshold levels of these disorders to help prevent them from experiencing an AUD or MDD. If distorted cognitive processes underlie both depressive symptoms and alcohol-related problems, they present as an appropriate area of intervention for individuals with both disorders. Treatment approaches with individuals who have comorbid AUD and MDD often approach one disorder or the other, but rarely address the common factors exacerbating both.

This thesis may offer a comprehensive understanding of the relationship between distorted cognitive variables and the symptoms of both disorders to better understand how intervention strategies can address the symptoms of both disorders simultaneously. Already, there is evidence that addressing the underlying cognitive vulnerability of both disorders helps individuals suffering from this comorbidity (Riper et al., 2014). Therefore, evidence from this dissertation could further support these efforts and provide a theoretical rationale for third-wave approaches to treatment among individuals with concurrent disorders. This dissertation is dedicated to supporting the wide range of mental health and medical professionals who assist in the treatment of individuals with concurrent disorders in health care and community-based settings.

Chapter 2

2 Study One: The Community Study

The first study assessed the relationship between alcohol problems, cognitive distortions (operationalized as dysfunctional attitudes), and depressive symptoms in a community sample across time. Specifically, this study was designed to test the mediating effects of dysfunctional attitudes on the relationship between alcohol problems and depressive symptoms over time (see *Figure 2*). This protocol for this study was approved by the Research Ethics Board of the University of Western Ontario (REB# 108660).

2.1 Design

The Community Study employed a longitudinal prospective cohort design with five waves of data collection, three months apart (baseline, three months, six months, nine months, one year). All participants received the same measures at all five time points.

2.1.1 Time Interval Considerations.

Determining how much time to allot between intervals was challenging. It is important to re-assess individuals at time periods where one would reasonably expect to detect some variability in alcohol problems, depressive symptoms, and cognitive variables. Data from The National Population Health Survey (NPHS) in Canada (Patten, 2006) suggests that the duration of depressive episodes varies widely; 48.5% of individuals with depression will recover after three months, 61% after six months, and 74.3% after one year. Symptoms tend to stay relatively stable if they do not remit following one year (Patten, 2006). Therefore, it would be reasonable to expect that

measuring depressive symptoms at three, six, and 12 months would allow for some variability in symptoms to be detected. Further, a longer timeline would allow for more detection of emerging depressive symptoms among individuals who did not experience these symptoms at baseline. Additionally, depression is a highly recurrent condition (Bockting, Hollon, Jarrett, Kuyken, & Dobson, 2015). Individuals who have suffered a previous depressive episode have a 40-60% chance of relapsing, often within 6-12 months (Bockting et al., 2015). Relapse rates increase dramatically after the second (60%) and third (90%) depressive episodes (Bockting et al., 2015; Eaton et al., 2008); therefore, it would be important to measure changes in depression across relatively long periods of time (e.g., one year).

There is little information on the average duration of an AUD. Research suggests that AUDs tend to remit on their own, however. A study using American large-scale survey data suggests that 75% of individuals who report previous alcohol dependence (according to the DSM-IV; APA, 1994) no longer meet diagnostic criteria (Dawson, Grant, Stinson, Chou, & Huang, 2005). However, relapse rates are high. Approximately 60% of individuals with AUD will relapse at some point in the future (Moos & Moos, 2006). The limited information on duration of AUD episodes and specific time estimates for relapse rates makes it challenging to estimate what time intervals would be best suited to detect changes in these symptoms across time.

Dysfunctional attitudes are known to be relatively stable across time, but also to vary with changing mood levels and greater life stress (C. E. A. Wang, Halvorsen, Eisemann, & Waterloo, 2010). Therefore, it was expected that changes in dysfunctional attitudes would be more individualized (based on changes in mood, life events, and

symptoms of mental disorder over time). To allow for as much variability in these symptoms as possible (thus increasing the chances of detecting relationships between these variables), the present study collected information on alcohol problems, depressive symptoms, and dysfunctional attitudes at three-month intervals (February 2017, May 2017, August 2017, November 2017, and February 2018) for one year (see *Figure 2*).

This design presents an opportunity to evaluate how alcohol problems, depressive symptoms, and dysfunctional attitudes change and relate to each other over three-month intervals (*Figure 2*) and six-month intervals (*Figure 3*). This design also provides an opportunity to determine whether mediating relationships are stable over time and whether they replicate across time points (*Figure 3*).

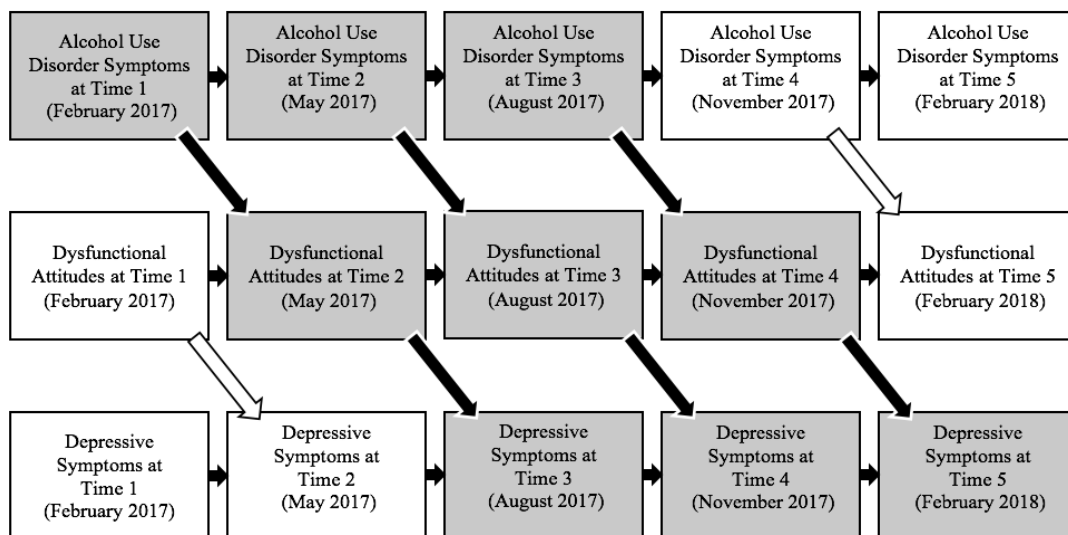

Figure 2. Full longitudinal mediation model of the relationship between alcohol use, dysfunctional attitudes, and depressive symptoms at three-month intervals.

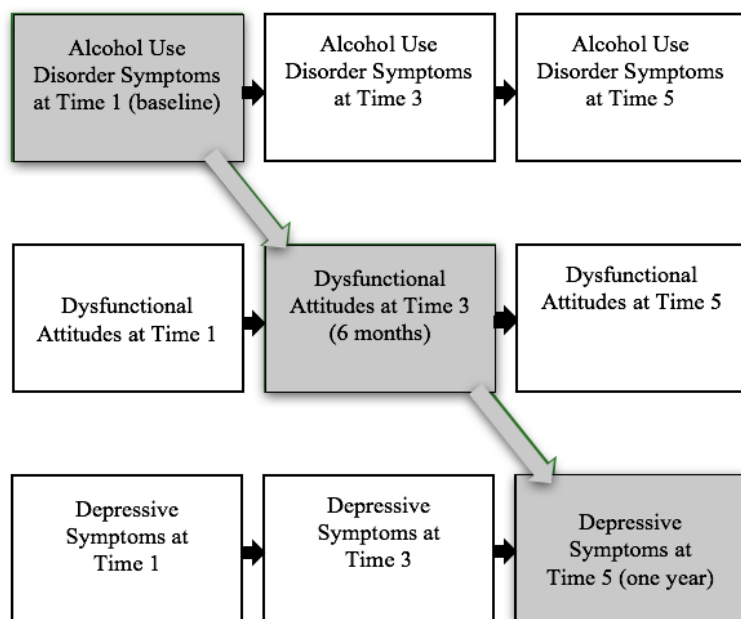

Figure 3: Longitudinal mediation model at six-month intervals.

2.2 Sample Size

The analytic procedures discussed below involve several longitudinal path analyses and cross-sectional structural equation models. Monte Carlo simulations have recently been termed the most robust and sophisticated method of estimating sample size for confirmatory factor analyses, path analyses, and structure equation models (Wolf, Harrington, Clark, & Miller, 2013). Wolf and colleagues computed several simulated models to estimate the required sample size of studies that involve missing data, regressive models, and moderate factor loadings. These researchers concluded that a sample size of 450+ is generally sufficient to detect small effects. They also note, however, that for mediation analyses, it is important to have a larger sample size (as indirect effects tend to be small), and when anticipating missing data.

Studies assessing the relationship between alcohol use, distorted cognitions, and/or depression range widely in their sample sizes, from less than 200 participants (Gjestad et

al., 2011) to just over 1000 participants (Fergusson et al., 2009). Twelve hundred participants were recruited for the present study to ensure sufficient power to detect small effects, and to account for the likelihood of missing data. Similar longitudinal studies (e.g., Brière et al., 2014; Fergusson et al., 2009) have experienced approximately a 20% attrition rate. This sample size was also sufficient for the largest model being tested (which had 50 parameters to estimate).

2.3 Sample

Participants were recruited through Amazon Mechanical Turk's, TurkPrime. Participants needed to be registered "workers" on TurkPrime, to have a 90% approval rating on the site (meaning that they were in good standing with other researchers on the site). All TurkPrime "workers" are 18 years of age or older and speak fluent English. To ensure that participants were generally culturally homogeneous, they were exclusively recruited from Western countries: United States, Canada, Australia, the United Kingdom, and Ireland. The vast majority TurkPrime workers are American. Demographic data are presented in *Table 1*. According to the most recent available US Census Data from 2017 (<https://www.census.gov/quickfacts/fact/table/US/PST045217>), the sample was highly representative of the age, sex, ethnicity, education, and marital status of Americans. A negligible number of participants were from Western countries outside of the US (largely because MTurk requires an American address to become an MTurk worker). The sample was primarily ethnically white and participants were predominantly between the ages of 25-44. The sex distribution was relatively even.

Table 1. Demographic Statistics for the Community Sample

	Age (%)	Sex (%)	Ethnicity (%)	Country of Residence (%)	Marital Status (%)	Education (%)
Time 1 <i>N</i> = 1090	18-24 (11.70)	Male (55.00)	White (76.30)	USA (98.70)	Single (41.31)	High school (12.01)
	25-34 (46.74)	Female (45.00)	Hispanic (5.90)	Canada (.90)	Committed relationship (16.22)	College (26.10)
	35-44 (23.51)	Other (.10)	African American (7.10)	UK (.30)	Married/common law (33.62)	Trade School (3.32)
	45-54 (11.12)		Native American (.90)	Ireland (.10)	Widowed (.61)	Associates (10.80)
	55-64 (5.20)		Asian (7.80)		Divorced (7.11)	Bachelor (37.10)
	65-74 (1.70)		Middle Eastern (.10)		Separated (1.20)	Master's (8.23)
	75+ (.10)		Mixed Race (1.70)			Professional (1.50)
						PhD (1.00)
Time 2 <i>N</i> = 738	18-24 (8.00)	Male (52.00)	White (77.00)	USA (98.48)	Single (38.61)	High school (12.02)
	25-34 (46.61)	Female (47.80)	Hispanic (5.00)	Canada (.89)	Committed relationship (17.12)	College (24.70)
	35-44 (25.60)	Other (.10)	African American (8.00)	UK (.40)	Married/common law (35.61)	Trade School (1.89)
	45-54 (12.53)		Native American (.80)	Ireland (.10)	Widowed (1.22)	Associates Degree (12.10)
	55-64 (5.72)		Asian (6.90)		Divorced (6.60)	Bachelors (38.12)
	65-74 (1.64)		Middle Eastern (.10)		Separated (.80)	Masters (8.81)
	75+ (.00)		Mixed Race (2.20)			Professional (1.50)
						PhD (.90)
Time 3 <i>N</i> = 576	18-24 (6.91)	Male (52.30)	White (78.50)	USA (99.02)	Single (39.12)	High school (12.10)
	25-34 (42.90)	Female (47.60)	Hispanic (4.50)	Canada (.88)	Committed relationship (15.50)	College (23.11)
	35-44 (28.01)	Other (.20)	African American (7.60)	UK (.20)	Married/common law (37.31)	Trade School (2.80)
	45-54 (13.00)		Native American (.50)	Ireland (.00)	Widowed (.90)	Associates (11.82)
	55-64 (7.30)		Asian (6.30)			Bachelor (38.91)
	65-74 (1.93)		Middle Eastern (.00)			Master's (8.92)
	75+ (.00)					Professional (1.64)

			Mixed Race (2.60)		Divorced (6.80) Separated (.50)	PhD (.90)
Time 4 N = 677	18-24 (5.51)	Male (53.00)	White (78.91)	USA (98.71)	Single (39.12)	High school (10.62)
	25-34 (43.71)	Female	Hispanic (4.74)	Canada (.60)	Committed	College (23.51)
	35-44 (27.82)	(47.00)	African American (7.44)	UK (.60)	relationship (14.32)	Trade School (3.53)
	45-54 (14.23)	Other (.00)	Native American (.40)	Ireland (.00)	Married/common	Associates (11.41)
	55-64 (6.94)		Asian (6.5)	Other (.10)	law (37.42)	Bachelor (39.70)
	65-74 (1.82)		Middle Eastern (.00)		Widowed (.90)	Master's (9.20)
	75+ (.10)		Mixed Race (2.10)		Divorced (7.41) Separated (.90)	Professional (1.21) PhD (.90)
Time 5 N = 617	18-24 (5.00)	Male (53.00)	White (78.92)	USA (98.43)	Single (40.22)	High school (12.31)
	25-34 (41.30)	Female	Hispanic (5.02)	Canada	Committed	College (23.82)
	35-44 (29.81)	(47.00)	African American (6.23)	(1.11)	relationship (14.31)	Trade School (3.90)
	45-54 (13.89)	Other (.00)	Native American (.502)	UK (.50)	Married/common	Associates (10.51)
	55-64 (7.60)		Asian (7.90)	Ireland (.00)	law (35.72)	Bachelor (38.40)
	65-74 (2.32)		Middle Eastern (.00)		Widowed (.80)	Master's (9.40)
	75+ (.00)		Mixed Race (2.41)		Divorced (8.11) Separated (1.00)	Professional (.80) PhD (.80)

2.4 Measures

2.4.1 Demographic Information

Demographic questionnaire. Participants were asked about their current age, sex, educational background, and ethnic background.

2.4.2 Alcohol Use Measures.

Alcohol Use Disorders Identification Test – Self-Report Version (Bohn, Babor, & Kranzler, 1995; Saunders, Aasland, Babor, Fuente, & Grant, 1993). The AUDIT is a 10-item self-report questionnaire designed by the World Health Organization to screen for AUDs. This scale assesses frequency of drinking, quantity of alcohol consumed on each drinking occasion, and consequences related to drinking (e.g., frequency of memory loss, injury due to drinking). Participants were asked to evaluate each item on a five-point scale, with higher numbers indicating greater frequency, quantity, or negative consequences of alcohol use. Scores in the range of 20-40 are generally considered high enough to warrant a referral for diagnostic evaluation and treatment. The AUDIT stands out from other AUDs screening measures because it was constructed based on a large multinational sample and specifically identifies hazardous drinking in the recent past, rather than lifetime alcohol use problems (Allen, Litten, Fertig, & Babor, 1997). Further, it has been referred to as the most psychometrically sophisticated AUD screening test, when compared to over 22 self-report AUD screening measures (Allen et al., 1997). The reliability of the total score for this scale in the present sample was high ($\alpha = .90$). The reliability for the three subscales was also acceptable; Audit Hazardous ($\alpha = .77$), Audit Dependence ($\alpha = .84$), and Audit Harmful ($\alpha = .79$). Importantly, however, confirmatory

factor analyses (see section 2.7.1) suggest that a one-factor solution best represents these data, therefore there is little evidence to suggest that these three subscales are measuring distinct constructs, which may explain the lower reliability estimates.

Rutgers Alcohol Problems Index (White & Labouvie, 1989). The RAPI is a 23-item self-report measure of problems encountered as a result of alcohol use in the last 12 months (e.g., neglecting responsibilities, going to work or school drunk, or interpersonal conflicts). Participants were asked to evaluate how often each problem has arisen in the last twelve months on a four-point scale from 0 = *never* to 3 = *more than five times*. Possible total scores range from 0 to 69. Although no cut-off score is specifically presented for the RAPI, mean scores in clinical populations are 26 for women ($n = 15$) and 20.1 for men ($n = 43$) between 17 and 18 years old (White & Labouvie, 1989).

The authors indicate that the RAPI can be adapted to a different time point without jeopardizing its psychometric properties (White & Labouvie, 1989). To avoid any overlap between the two time points in this study, participants were asked to indicate how often each problem arose in the last three months, rather than 12 months. This scale was originally designed for use with adolescents and young adults, although it was used for a general adult population in the present study. The reason for this decision is that previous studies have indicated that the RAPI has been shown to predict cognitive distortions, which maps onto the hypotheses in the present study (Willem et al., 2014). The RAPI is currently the most widely used measure of problematic drinking patterns in the alcohol literature (Dick, Aliev, Viken, Kaprio, & Rose, 2011). The reliability of this total score for this scale in the present sample was high ($\alpha = .95$). The reliability for the

two subscales was also high; RAPI Social/Occupational Consequences ($\alpha = .90$), RAPI Dependence/Withdrawal ($\alpha = .91$).

2.4.3 Mood Measures.

Beck Depression Inventory (Beck, Steer, & Brown, 1996). The BDI-II is a 21-item self-report questionnaire designed to measure the presence and severity of depressive symptomatology in the last two weeks. Respondents select one item from each of the 21 statement groups. Choices range from 0 = *not present* to 4 = *severe*. Total scores range from 0 to 63. The psychometric properties of the BDI-II have been well established (Beck et al., 1996; Dozois, Dobson, & Ahnberg, 1998). In the present sample, internal consistency was excellent, Cronbach's alpha = .96.

Visual Analog Mood Scale (VAMS; Stern, Arruda, Hooper, Wolfner, & Morey, 1997). The VAMS is a commonly used one-item measure of mood that has been found to accurately distinguish between individuals with depressed and non-depressed mood. This measure has shown excellent sensitivity, specificity, and convergent validity with other mood scales (Killgore, 1999; Nyenhuis, Yamamoto, Stern, Luchetta, & Arruda, 1997). On this measure, participants were asked to make a single mark on a straight line anchored by "happy" and "sad".

2.4.4 Measures of Distorted Cognitive Processes

Dysfunctional Attitudes Scale-SF (DAS-SF; Beevers, Strong, Meyer, Pilkonis, & Miller, 2007). The original DAS (Weissman & Beck, 1978) is a 40-item self-report questionnaire designed to assess the degree to which participants endorse statements that are considered to be dysfunctional (e.g., "if a person asks for help, it is a sign of weakness"). This measure has been repeatedly used in research related to depression and

AUDs (Chabon & Robins, 1986; Gjestad et al., 2011). Studies have also found this measure to reliably distinguish between clinical and non-clinical populations (Dobson & Shaw, 1986). Two parallel short forms of this measure were recently developed by Beevers and colleagues (2007) using non-parametric item response theory. The present study used the two 9-item parallel versions of the DAS (DAS_A and DAS_B) created by Beevers and colleagues. These short form measures correlate between .91 and .93 with the original 40-item version and have been found to reliably and accurately measure dysfunctional attitudes in research samples. In the present sample, the internal consistency of DAS_A was excellent (Cronbach's alpha = .88) and DAS_B was acceptable ($\alpha = .73$).

2.4.5 Sad Mood Induction

Adapted Velten Mood Induction (Velten, 1968). The sad mood induction procedure employed in the present study was based on the Velten negative mood induction procedure, whereby participants are exposed to self-referent sad mood-inducing statements and are explicitly asked to try and feel the mood being elicited by these statements. The statements were taken from Jennings, McGinnis, Lovejoy, & Stirling (2000). All 23 statements that were found to have a significantly negative valence were included in the present study. Statements included, "when I talk no one really listens" and "I'm tired of trying". Each statement is flashed across the screen for 12 seconds (Göriz & Moser, 2006).

Studies have continually shown that the Velten sad mood induction reliably induces a negative mood among participants (Martin, 1990). A limitation of the Velten procedure is that only 30% to 50% of individuals experience a negative mood following this

procedure (Clark, 1983). To further facilitate the induction of sad mood, researchers have begun to combine mood-induction procedures. For example, Fox and her colleagues (1998) combined the Velten mood induction procedure with a musical mood induction procedure, whereby participants listen to sad music while reading the sad statements. This procedure was found to significantly lower participants' moods, compared to a neutral mood induction procedure (where participants read statements that were unrelated to mood). Gillies (2018) suggests that a sad music induces a low mood for approximately 4 minutes, which is sufficient to complete the short-form measure of dysfunctional attitudes (DAS) included in this study. Data have also found that the Velten mood induction procedure is both effective in online studies and is the most time-efficient of all mood induction procedures (Gillies, 2018; Göritz & Moser, 2006). In the present study, the music used was Alexander Nevsky's *Russia Under the Mongolian Yoke*, remastered at half speed. This specific track has been used in multiple sad mood induction procedures in the past (Gillies, 2018; Knight, Maines, & Robinson, 2002; Segal, Gemar, & Williams, 1999) and has been specifically used in mood induction procedures that combined Velten and musical mood induction procedures (Knight et al., 2002).

2.4.6 Attention Checks

Six attention checks (e.g., "please select option three for this answer") were placed randomly throughout the study to ensure that participants were attending to the study. Participants answered anywhere from 2-6 attention checks, depending on how many questionnaires they completed (e.g., participants who did not drink alcohol did not get the attention checks embedded into the alcohol measures).

2.5 Procedure

Participants were paid \$1.50 USD to participate in the first wave of data collection, and \$2 USD to participate in the second, third, fourth, and fifth waves to promote retention. All measures for this study were presented to participants on a privately coded website, which they accessed by clicking a link available to them on the TurkPrime website, once they clicked the “HIT” for the study. TurkPrime workers who volunteered to participate in the study read a Letter of Information and Consent (Appendix A) to familiarize themselves with the study. They also re-consented to the study at each time point, and the Letter of Information and Consent was amended appropriately (e.g., to welcome to them to the current phase, inform them of how many phases remained). Participants were also informed that the study involved music (as part of the sad mood induction procedure) and were asked to complete the study either with headphones, or in a quiet space with their speakers turned on. Participants were then given the series of questionnaires on demographics, alcohol, depression, and cognitive distortions.

Most participants were also led through a sad mood induction procedure after completing measures of depression, alcohol use, and baseline cognitive distortions. These participants were given a counterbalanced, parallel measure of cognitive distortions before and after the sad mood induction procedure to ensure that the sad mood induction procedure had activated latent cognitive processes. Given that participants in this study were not pre-screened for depression, the measure of depression included in this study, the Beck Depression Inventory-II (Beck et al., 1996), also served as a short screening questionnaire. If participants completed the depression questionnaire and had high levels of depression (BDI-II scores of 29+), they were automatically diverted around the sad

mood induction procedure. This diversion was coded into the software of the study's website. The decision to divert individuals who had high levels of depression was made because individuals who are already experiencing depression should theoretically have their cognitive distortions activated, and would not need for them to be induced. Further, exposing individuals with high levels of depression to tasks that are designed to further lower their mood has ethical implications.

To ensure that the sad mood induction procedure was effective in activating dysfunctional attitudes (and to add a between-subjects analysis of the efficacy of the sad-mood induction), a subgroup of participants ($n = 300$) with low-moderate depressive symptoms at Time 1 were automatically diverted around the sad mood induction procedure. This methodology provided an opportunity to compare the dysfunctional attitudes among people who did and did not receive the sad mood induction. Only participants who were led through the sad mood induction procedure completed both versions of this scale, one before and one after the sad mood induction. Participants were led through the study in this order:

1. Brief demographic questionnaire (5 minutes);
2. Two alcohol use measures (5-7 minutes);
3. A measure of depressive symptomatology (5-7 minutes);
4. Visual Analog Mood Scale to assess current mood (5 seconds);
5. A short-form measure of dysfunctional attitudes (3 minutes);
6. Participants who were not currently depressed (and who had not been randomly assigned to bypass the sad mood induction) were led through a mood induction procedure to induce sad mood (5 minutes). *Participants in Time 1 who were*

currently depressed or who had been randomly assigned to bypass the sad mood induction procedure finished the study at this point and were debriefed at Time 5. In Times 2-5, only participants who were experiencing severe levels of depression bypassed the mood prime;

7. Visual Analog Mood Scale to assess their current mood (5 seconds);
8. Manipulation check to see if participants were properly led through the sad mood induction;
9. A second, parallel, short-form measure of dysfunctional attitudes (3 minutes);
10. Positive mood induction (1 minute). Participants wrote about something happy that happened in their lives;
11. Participants were then given a third Visual Analogue Scale to monitor whether their mood improved following Step 10.
12. At Time 5: participants were debriefed (Appendix B).

Total time: approximately 15-30 minutes

2.6 Hypotheses

The Community Study's design allows for several hypotheses to be developed, both longitudinal and cross-sectional.

2.6.1 Cross-Sectional Hypotheses

In addition to assessing the relationship between alcohol problems, dysfunctional attitudes, and depressive symptoms over time, this study also assessed how these variables are related to each other at any given point in time. All three variables were assessed at each time point, and cross-sectional mediation models were tested at each time point.

2.6.1.1 Mediation Hypotheses

1. At Times 1, 2, 3, 4, and 5, alcohol problems and depressive symptoms will be significantly correlated with each other, and dysfunctional attitudes will account for a significant proportion of the variance of this relationship.

2.6.1.2 Moderated Mediation Hypotheses

1. At Time 1 (the model with the most power to detect small effects), the mediation model proposed above will be significantly moderated by sex, such that the indirect effect will be stronger for women compared to men.

2.6.2 Longitudinal Hypotheses

2.6.2.1 Mediation Hypotheses

The hypothesized pathways shown in *Figures 2 and 3* were tested in turn.

1. Changes in alcohol problems will predict changes in dysfunctional attitudes across three-month and six-month intervals;
2. Changes in dysfunctional attitudes will predict changes in depressive symptoms across three-month and six-month intervals;
3. Changes in alcohol problems will directly predict changes in depressive symptoms across six-month and 12-month intervals;
4. Dysfunctional attitudes will mediate the relationship between alcohol problems and depressive symptoms across six-month and 12-month intervals;

2.6.3 Moderated Mediation Hypotheses

1. The hypothesized indirect effect of dysfunctional attitudes on the relationship between alcohol problems and depressive symptoms will be stronger for women compared to men.

2.7 Analyses for the Community Study

Analyses related to duplicate data sets, attention checks, outliers, analyses of non-normality, and missing data are presented in Appendix B. Descriptive statistics are presented in *Table 2* (for a description of this table, also see Appendix B). Paired Samples t-tests² were employed to test whether the two versions of the DAS (A and B) were sufficiently similar to be considered parallel, and to determine whether the Velten Mood Induction procedure was successful in increasing dysfunctional attitudes across all five time points. That is, all pre-mood induction DAS scores were compared to all post-mood induction DAS scores. Descriptive statistics and frequency tables were computed for all demographic information, analyses of failing attention checks, and manipulation check questions (see Appendix B). In general, while there is some evidence that dysfunctional attitudes increased following the prime, the effect was not consistent across time points, and Time 1 data does not suggest that the prime is the specific cause of these changes. There was also no evidence that the two parallel versions of the DAS were equivalent.

² A paired-samples t-test was conducted rather than a chi-squared test because the data for the DAS were normally distributed.

Table 2. Descriptive Statistics of Time 1 Community Data

Scale	N	M	SD	Skewness	Kurtosis	Min	Max
AUDIT Total	901	7.00	6.84	1.69	2.49	0	34
Hazardous Dependence	901	4.19	2.71	.83	.04	0	12
Harmful	901	1.09	2.18	2.43	5.62	0	12
RAPI Total	900	1.71	2.79	2.04	3.96	0	15
Social/Occupational Dependence/Withdrawal	900	5.22	9.29	2.48	5.90	0	49
	900	2.01	2.01	3.04	10.04	0	28
BDI	901	2.70	2.07	2.39	5.47	0	26
Somatic Cognitive	1088	11.22	12.17	1.34	1.37	0	60
	1086	5.99	6.29	1.28	1.32	0	31
DAS A	1087	5.22	6.49	1.45	1.50	0	30
DAS B	717	16.56	5.38	.56	-.70	9	36
	719	18.53	4.36	.33	-.34	9	33

2.7.1 Confirmatory Factor Analyses of the Measures

Confirmatory factor analyses (CFA) with maximum likelihood extraction were conducted using SPSS Version 24 (IMB SPSS Statistics, 1989-2016) on the RAPI, AUDIT, DAS, and BDI-II to determine whether separating these scales into their theoretical dimensions and using subscale scores was warranted. Exploratory factor analytic procedures were used to determine whether the pre-established factors could be confirmed, and to evaluate whether any additional factors existed. Although unconventional, using exploratory analyses to conduct these CFA's offers an opportunity to evaluate the factor structure of these scales as well as identify new factors structures within this population. All analyses were conducted on Time 1 data (see Appendix C). The RAPI's CFA as well as the BDI-II's CFA indicated that the two predetermined subscales fit the data well for each of these measures. The CFAs with the AUDIT and the DAS only supported a one-factor solution. Thus, only the total score of the DAS was used and results based on the subscales of the AUDIT should be interpreted with caution.

2.8 Data Analytic Techniques for Community Sample

2.8.1 SPSS Analyses

Descriptive analyses, ANOVAs, t-tests, factor analyses, reliability analyses, and most correlational analyses were conducted using SPSS Versions 24 and 25 (IBM SPSS Statistics, 1989-2016; 2017). Cronbach's alpha was computed for all measures and the reliability estimates are presented within the methods section, with each respective measure.

2.8.2 MPlus Analyses

Path analyses, structural equation models, and some correlational analyses were conducted in Mplus Version 7.4 (Muthén & Muthén, 1998-2015) using Maximum Likelihood estimation, which is robust to non-normality of data and missing data, and has been used frequently in longitudinal analyses (Kim, 2013; Li, 2016; Ory & Mokhtarian, 2009, 2010; Wolf et al., 2013). Path analytic models were tested for all longitudinal hypotheses to determine whether the hypothesized relationships between alcohol variables, dysfunctional attitudes, and depression fit the observed data, and whether dysfunctional attitudes were a significant mediator. Separate path models were conducted with the AUDIT and the RAPI as the predictors to ensure that the number of observations per estimated parameter had adequate power to detect significant relationships. Structural equation models, which included latent and observed variables, were tested for all cross-sectional analyses. Adding latent variables to the analyses reduces error variance and allows for a more robust analyses of the relationships between variables. Further, latent variables allow for multiple factors of a construct to be included (e.g., the latent variable

“alcohol-related problems” can include the information about consumption, physiological consequences of alcohol use, and alcohol problems).

Chapter 3

3 Results

3.1.1 Attrition

A variable named “missingness” was computed for each time point to determine whether presence or absence in each time point correlated with measures of interest from time one (e.g., alcohol problems, depressive symptoms, DAS). The variable “missingness” coded presence or absence in each time point as 1 = present, 0 = absent. These variables were then added up to indicate the degree of “missingness” (from 0 – 4). Small (Cohen, 1988) but statistically significant positive correlations between “missingness” across the time points and Time 1 BDI-II ($r = .11, p < .01$), Time 1 AUDIT Total ($r = .14, p < .01$), Time 1 RAPI ($r = .20, p < .01$), and Time 1 DAS B ($r = .08, p = .01$), but not DAS A ($r = .05, p = .17$), were found.

These findings indicate that individuals with higher levels of depression, alcohol use disorder symptoms, and dysfunctional attitudes (but only on the DAS B) were more likely to drop out of one or more time points. Thus, participants may have dropped out of the study at different time points partly due to changes in these variables. There was also a small, significant, negative correlation between age and missingness ($r = -.17, p < .01$), such that younger participants were more likely to leave the study over time compared to older participants. No other demographic variables were associated with attrition over time.

3.1.2 Correlations Between All Variables at Time 1

To better understand how these variables are related to each other in this sample, bivariate correlations were computed for the variables at Time 1. *Table 3* shows that all alcohol measures correlated strongly with each other and the BDI-II correlated very strongly with its subscales. Correlations between the alcohol measures and the depression measures ranged from small to moderate. Specifically, the Hazardous drinking subscale of the AUDIT (which measures frequency and amount of alcohol consumption) had the weakest association with the total score of the BDI-II ($r = .21$) compared to any other measures of alcohol problems. The Harmful drinking subscale, which measures guilt around drinking, being injured or injuring another person while intoxicated, having people tell you that they are worried about your drinking, and memory loss from drinking, was most highly associated with overall depressive symptoms ($r = .40$). Depressive symptoms were also highly associated with alcohol problems, in general, as demonstrated by the moderate association between total RAPI and BDI-II scores.

The correlation between the Hazardous drinking subscale and total BDI-II scores was statistically significantly lower than the correlations between total BDI-II scores and both the Harmful drinking ($n = 903$, $z = 4.46$, $p < .01$) subscale and the total RAPI scores ($n = 903$, $z = 4.72$, $p < .01$). Therefore, the association between depressive symptoms and harmful drinking (which is characterized by guilt and impairment) and drinking problems is significantly stronger than the association between depressive symptoms and the amount or frequency of drinking³.

³ These calculations were conducted using the Free Statistics Calculator Version 4.0 (Soper, 2018).

Correlations between the alcohol measures and the DAS score were small; and the RAPI correlated more strongly with the DAS compared to the AUDIT and its subscales. Specifically, again, the Hazardous drinking subscale of the AUDIT had the weakest correlation with the DAS ($r = .10$). The Social and Occupational Consequences of Drinking subscale of the RAPI had the strongest correlation ($n_{das} = 475$, $n_{rapi_soco} = 476$, $z = 2.71$, $p < .01$) with the DAS, which was almost moderate in size ($r = .27$). Therefore, there is more evidence that the consequences of drinking, rather than the amount or frequency of drinking, is related to dysfunctional attitudes.

Correlations between the DAS and the BDI-II were moderate. The weakest correlation was between the DAS and the somatic subscale of the BDI-II ($r = .36$) and the strongest correlation was with the cognitive subscale ($r = .49$). These correlations were also statistically significantly different from each other ($n_{DAS} = 564$, $n_{BDI-II} = 563$, $z = 2.66$, $p = .01$). Given that dysfunctional attitudes are a cognitive process, this finding is not surprising.

3.1.3 Correlations Between Variables at Different Time Points

To assess the degree to which variable scores at different time points correlated with each other, bi-variate correlations were conducted with each time points' scores on the same variables (see *Table 10*, Appendix D). In general, the same variables have a stronger relationship to each other at closer time intervals compared to farther time intervals. RAPI and DAS scores had lower correlations over time compared to BDI and AUDIT scores over time. All correlations were significant at the $p = .01$ level (see Appendix D).

3.1.4 Prevalence of “Clinical” Levels of Depressive Symptoms and Alcohol Use

According to the National Institutes on Alcohol Abuse and Alcoholism’s 2015 survey <https://www.niaaa.nih.gov/alcohol-health/overview-alcohol-consumption/alcohol-facts-and-statistics>, 6.2% of Americans were currently experiencing an AUD. In the present study, 72 (6%) participants had scores of 20 or higher on the AUDIT and 85 (7%) had scores of 20 or higher on the RAPI. Therefore, the prevalence of clinical levels of alcohol use disorder symptoms was comparable to the overall American population. The 2017 National Survey on Drug Use and Health (<https://www.samhsa.gov/data/sites/default/files/cbhsq-reports/NSDUHDetailedTabs2017/NSDUHDetailedTabs2017.htm#tab8-56A>) show overall prevalence rates of depression at 7.1%. In the present study, 109 (10%) of participants endorsed levels of depressive symptoms in the clinical range (29+) on the BDI-II. Thus, this prevalence rate is slightly higher than the American national average. Given how few individuals in this study would likely meet criteria for an AUD or an MDD, no meaningful longitudinal analyses among individuals with “clinical” levels of these disorders could be conducted.

3.1.5 Variability in Alcohol Problems, Dysfunctional Attitudes, and Depressive Symptoms over One Year

To determine whether depressive symptomatology, alcohol problems, and dysfunctional attitudes significantly changed over time, and across sex at each time point, a mixed between/within subjects repeated-measures ANOVA was conducted with sex as the between-subjects variables (2 levels: male and female) and time as the within-subjects variables (5 levels: Time 1, Time 2, Time 3, Time 4, and Time 5) for each measure using

IBM SPSS Statistics Version 25. Participants who did not attend all time points were omitted using listwise deletion. For an overview of the means and standard deviations for the whole sample across time points, and across sexes for each time point, please see *Table 11* in Appendix D. Major findings were consistent with the literature and suggested that depressive symptoms are higher among women, and alcohol problems are higher among men. There was some variability in scores throughout the year in alcohol problems and dysfunctional attitudes and no significant variability in depressive symptoms across the year.

3.2 Cross-Sectional Analyses

Cross Sectional Analyses were conducted using structural equation modeling techniques. Fit indices evaluated for each model included the Root Mean Square Error of Approximation (RMSEA), the Chi-square test of model fit (χ^2), the Comparative Fit Index (CFI), the Tucker-Lewis Index (TLI), and the Standardized Root Mean Square Residual (SRMR). The RMSEA, Chi-squared test, and SRMR are absolute fit indices and determine how well the hypothesized covariance matrices fit with the observed covariance matrices (Tabachnick & Fidell, 2007). The RMSEA is often used with the Chi-squared test as it is more sensitive to sample size and adjusts for the number of parameters in the model. The SRMR statistic is the square root of the difference between the residuals of the observed and hypothesized covariance matrices. The acceptable cut-off for the RMSEA statistic is .08 for the SRMR is .06.

Table 3. Correlations Between All Variables at Time 1, Community Study

	AUDIT Total	AUDIT Hazardous	AUDIT Harmful	AUDIT Dependence	RAPI Total	RAPI Dependence/ Withdrawal	RAPI Social/ Occupational	DAS	BDI-II Total	BDI-II Cognitive	BDI-II Somatic
AUDIT _{Total}	1										
AUDIT _{Hazardous}	.86**	1									
AUDIT _{Harmful}	.91**	.63**	1								
AUDIT _{Dependence}	.90**	.64**	.79**	1							
RAPI _{Total}	.82**	.59**	.79**	.80**	1						
RAPI Dependence/Withdrawal	.82**	.63**	.78**	.79**	.95**	1					
RAPI Social/Occupational Consequences	.70**	.47**	.70**	.71**	.93**	.77**	1				
DAS	.18**	.10*	.19**	.19**	.24**	.19**	.27**	1			
BDI-II _{Total}	.36**	.21**	.40**	.34**	.41**	.40**	.37**	.46**	1		
BDI-II _{Cognitive}	.35**	.21**	.38**	.34**	.39**	.38**	.34**	.49**	.95**	1	
BDI-II _{Somatic}	.33**	.19**	.38**	.31**	.39**	.37**	.36**	.36**	.95**	.81**	1

Note: Correlations which are significant at $p < .05$ level are marked with *, and $p < .01$ are marked with **.

If the hypothesized and observed models are not significantly different (i.e., the data fit the hypothesized model well), the Chi-squared will not be significant. The CFI and TLI are comparative fit indices, and do not use the Chi-square in its raw form, but compare the Chi-square value to a baseline model, whereby the null hypothesis is that all variables are unrelated or uncorrelated with each other. The cut-off points for these fit indices are conservatively .95 (Barrett, 2007; Tabachnick & Fidell, 2007). Before a structural equation model was tested, a measurement model was tested to ensure that all variables were significantly related.

3.2.1 The Measurement Model

Time 1 data were used to test the measurement model (*Figure 4*), as this sample has the highest power to detect associations between these variables (for the correlation matrix, see *Table 4*). A confirmatory factor analysis was conducted to assess the fit of a model whereby alcohol problems, dysfunctional attitudes, and depressive symptoms are associated with each other. Latent variables were constructed for alcohol problems and depressive symptoms by having the subscale scores for the AUDIT and RAPI questionnaires as indicators for the alcohol problems' latent variable and the subscales of the BDI-II as indicators of the depressive symptoms' latent variable. DAS scores were used as the mediating observed variable. The fit indices of the original model were slightly below the acceptable levels, $\chi^2(18) = 130.41, p < .01$, RMSEA = .10, 90% CI (.08, .012), $p < .01$, TLI = .94, CFI = .96, SRMR = .04. Although the overall fit of this model was not ideal, the standardized loadings for each latent variable were all high, appropriate values and there was no issue with the pattern of correlations. There was a strong association between the Depressive Symptoms latent variable and the Alcohol

Problems latent variable, a moderate association between the Depressive Symptoms latent variable and the Dysfunctional Attitudes indicator, and a small association between the Dysfunctional Attitudes indicator variable and the Alcohol Problems latent variable.

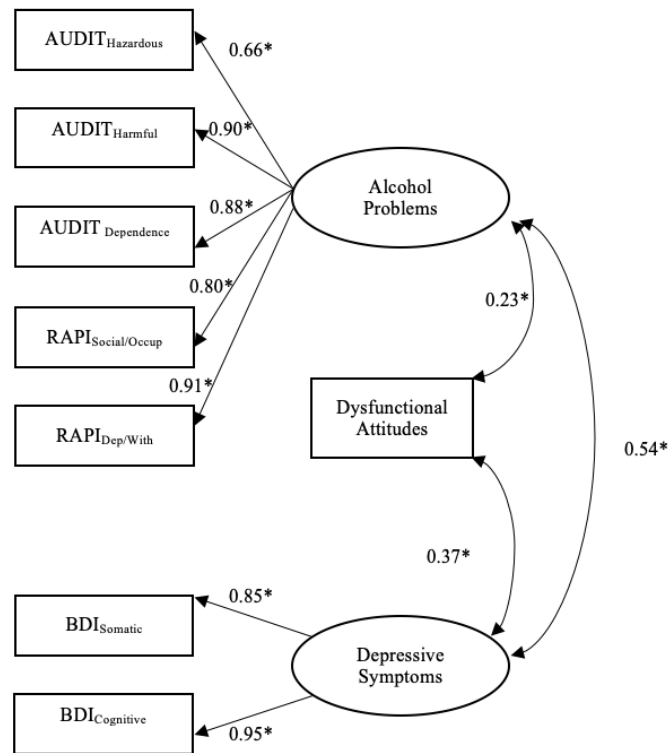

Figure 4. The final measurement model for the community sample, time 1 data used.

It is concerning that DAS scores showed only small correlations with the alcohol measures, and moderate correlations with the depression subscales. Further, correlations between the depression subscales and the alcohol subscales were somewhat low (especially for AUDIT Hazardous). Again, there is little indication that drinking large amounts of alcohol, frequently is strongly related to either depressive symptoms or dysfunctional attitudes.

Table 4. Correlation Matrix for all Variables in the Measurement Model of Time 1 Community Sample Data

	AUDIT Hazardous	AUDIT Dependence	AUDIT Harmful	RAPI Withdrawal	RAPI Social/ Occupational	BDI Cognitive	BDI Somatic	DAS
AUDIT Hazardous	1							
AUDIT Dependence	.63	1						
AUDIT Harmful	.62	.81	1					
RAPI Withdrawal	.59	.79	.80	1				
RAPI Social/ Occupational	.42	.67	.70	.78	1			
BDI Cognitive	.22	.43	.48	.48	.41	1		
BDI Somatic	.21	.38	.44	.43	.42	.81	1	
DAS	.03	.17	.17	.21	.28	.30	.34	1

3.2.2 The Structural Equation Models

All cross-sectional analyses were conducted using Structural Equation Modeling in MPlus using MLR and were based on the CFA above. In the Time 1 sample ($N = 1090$), the hypothesized structural equation fit the data well, $RMSEA = .08$, 90% CI (.07, .09), $p < .01$; $\chi^2(11) = 155.1$, $p < .01$; $CFI = .97$; $TLI = .95$; $SRMR = .03$. All paths were significant at the $p = .01$ level (*Figure 5*). The specific direct path from alcohol problems to depressive symptoms was significant ($b = .33$, $p < .01$) as was the specific indirect path from alcohol problems to depressive symptoms through dysfunctional attitudes ($b = .09$, $p < .01$). The mediating effect of dysfunctional attitudes accounted for 27% of the total

effect ($b = .42, p < .01$). Cross-sectional analyses of Times 2-5 are presented in Appendix E.

Figure 5. Cross-sectional structural equation model time 1 (standardized coefficients).

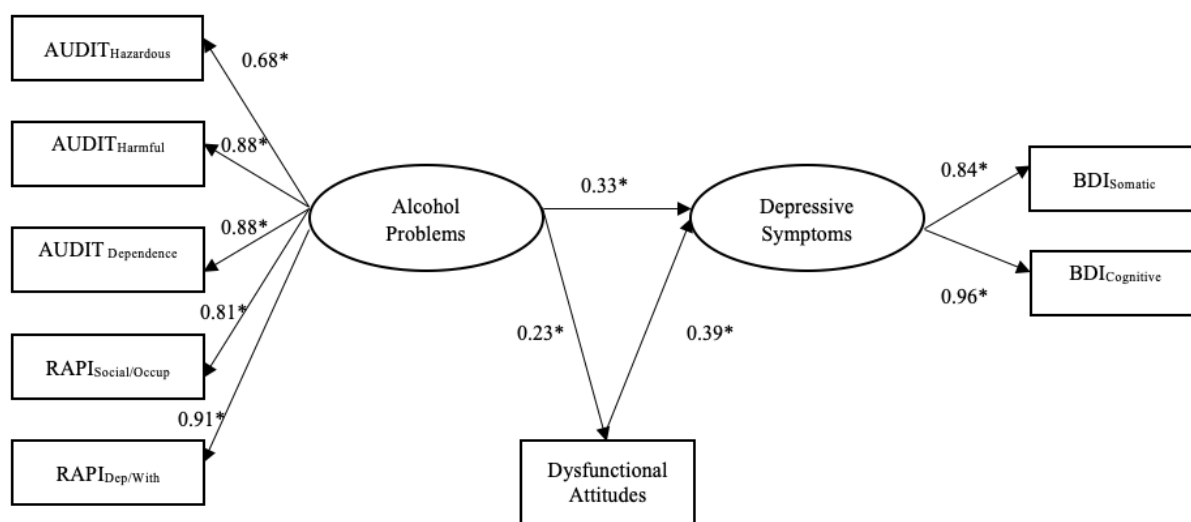

3.2.2.1 Cross-Sectional Moderated Mediation

To determine whether the significant mediation effect of DAS in the relationship between alcohol problems and depressive symptoms was moderated by sex, a moderated mediation analysis was conducted in the sample with the highest power to determine this effect (Time 1). The moderated mediation was accomplished by estimating the parameter estimates for both women and men and comparing each of them to see if the models fit significantly differently for each group. First, tests of measurement invariance across groups were conducted and the variance within indicators was comparable across groups. Therefore, differences between groups can be meaningfully interpreted (Milfont, 2010). The Wald Statistic of Parameter Constraints was used as a measurement of group differences using MPlus.

A significant difference between men and women was found ($w = 8.29, df = 1, p < .01$). A review of the specific indirect effects indicates that DAS scores ($b = .06, p < .01$) accounted for 11% of the total relationship between AUD and depressive symptoms for men ($.54, p < .01$), whereas DAS scores ($b = .13, p < .01$) accounted for 40% of the variance in the relationship between AUD and depressive symptoms ($b = .34, p < .01$) for women.

However, the total effect was stronger for men compared to women. The standardized regression coefficients between alcohol problems and depression for men were more than double what they were for women. For men, a one standard deviation increase in alcohol problems was associated with a .47 standard deviation increase in depressive symptoms. For women, a one standard deviation increase in alcohol problems was associated with a .20 standard deviation increase in depressive symptoms.

The relationship between depressive symptoms and dysfunctional attitudes had the opposite finding. For men, a one-unit increase in dysfunctional attitudes was associated with a .26-unit increase in depressive symptoms. For women, a one standard deviation increase in dysfunctional attitudes was associated with a .40 standard deviation increase in depressive symptoms. The relationship between AUD and dysfunctional attitudes was similar for both women ($b = .28, p < .01$) and men ($b = .23, p < .01$). Therefore, there is a stronger direct relationship between alcohol use and depressive symptoms at Time 1 for men and a stronger relationship between dysfunctional attitudes and depression for women. Overall, the mediated model from alcohol to depression through dysfunctional attitudes fit the women's data better than the men's data.

3.3 Longitudinal Analyses

Although not depicted in the figures below (for visual simplicity), all variables are correlated at each time point. All paths identified with a * are significant at the $p = .05$ level and all paths that are identified with a ** are significant at the $p = .01$ level. Figures are presented of the most interesting findings.

3.3.1 Results for the Path Model from AUDIT to BDI-II

The initial indices for this longitudinal analysis revealed poor model fit, ($n = 1090$), $\chi^2(67) = 994.54, p < .01$, RMSEA = .11, 90% CI (.11, .12), $p < .01$; CFI = .89; TLI = .84; SRMR = .09, however no modifications were made because the paths in this model are specific to the predetermined hypotheses. No significant paths emerged from AUDIT to DAS or from AUDIT to BDI-II. Significant paths emerged from Time 2 DAS to Time 3 BDI-II ($b = .06, p = .01$) and from Time 3 DAS to Time 4 BDI-II ($b = .07, p < .01$).

The path was also tested from Time 1 to Time 3 to Time 5 separately (*Figure 6*), to evaluate whether a six-month lag between these variables would allow for more change between them. This model, $n = 1090$, $\chi^2(16) = 136.48, p < .01$, RMSEA = .08, 90% CI (.07, .10), $p < .01$; CFI = .97; TLI = .93; SRMR = .05, fit the data extremely well. A significant cross-lagged path emerged from Time 3 DAS to Time 5 BDI-II ($b = .05, p = .04$). The paths from Time 1 AUDIT to Time 5 BDI-II ($b = .05, p = .07$) and from Time 1 AUDIT to Time 3 DAS had comparably-sized standardized coefficient, but were not statistically significant ($b = .05, p = .22$). Therefore, in the full model, there is no evidence that alcohol problems predicted dysfunctional attitudes six-months later, or that alcohol problems predicted depressive symptoms at any time point. There is evidence that dysfunctional attitudes predicted depressive symptoms three and six-months later.

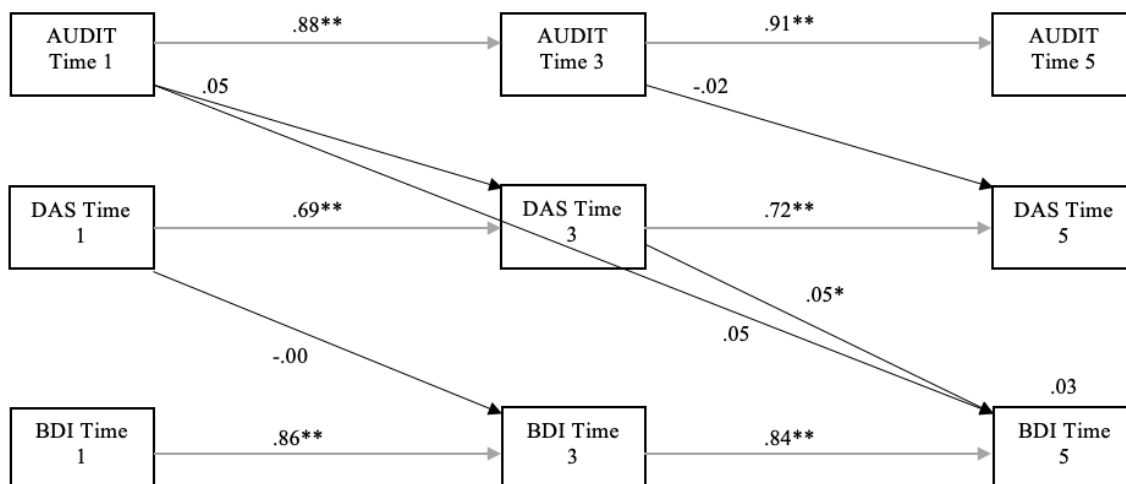

Figure 6. Longitudinal path model from alcohol use disorder symptoms (AUDIT) to depressive symptoms (standardized coefficients), six-month paths.

3.3.2 Moderated Mediation Analyses

The full model was tested with both women and men separately. The hypothesized models for women [$n = 491$, RMSEA = .11, 90% CI (.11, .12), $p < .01$; $\chi^2(67) = 493.16$, $p < .01$; CFI = .90; TLI = .84; SRMR = .09] and men [$n = 599$, RMSEA = .12, 90% CI (.11, .13), $p < .01$; $\chi^2(67) = 637.18$, $p < .01$; CFI = .87; TLI = .81; SRMR = .08], did not fit the data well, however paths were still evaluated for significance, as they correspond directly with hypotheses.

3.3.2.1 Women

The path model for women (*Figure 7*) showed that Time 3 AUDIT scores significantly predicted Time 4 DAS scores ($b = .09$, $p = .02$) and Time 2 DAS scores significantly predicted Time 3 BDI-II scores ($b = .10$, $p < .01$). A direct path from Time 3 AUDIT to Time 5 BDI-II also emerged for women, ($b = .07$, $p = .04$). Indirect paths were assessed and did not reveal any indirect paths from AUDIT to BDI-II.

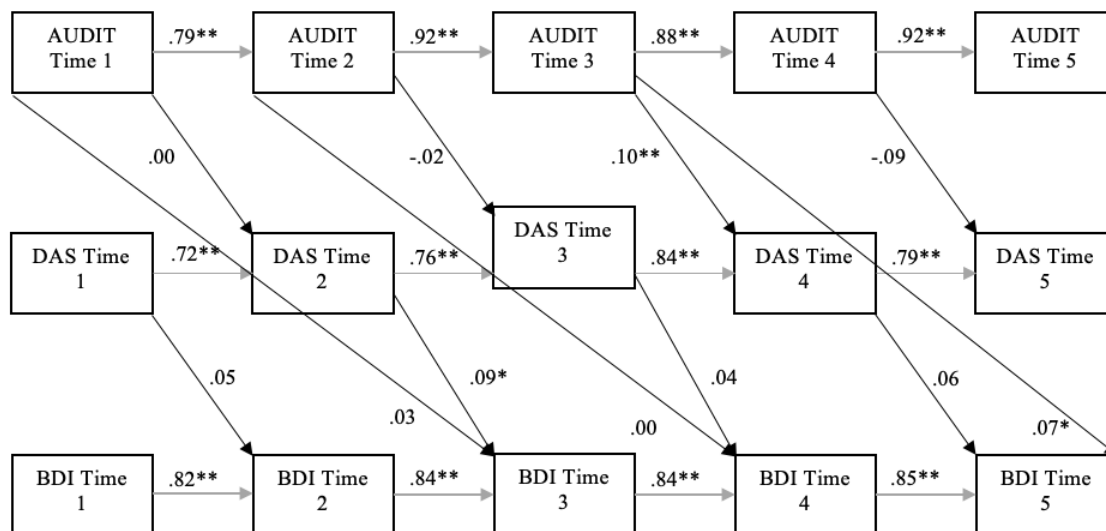

Figure 7. Cross-lagged paths alcohol use disorder symptoms (AUDIT) to depressive symptoms for women.

The model was also tested from Time 1 to Time 3 to Time 5 separately. This model, $n = 491$, $\chi^2(16) = 84.23$, $p < .01$, RMSEA = .09, 90% CI (.07, .11), $p < .01$; CFI = .96; TLI = .91; SRMR = .06, fit the data reasonably well. No significant cross-lagged paths emerged. Therefore, among women, there is some evidence of a direct relationship between alcohol problems and depression over six-month periods, as well as a relationship between alcohol problems and dysfunctional attitudes and dysfunctional attitudes and depressive symptoms three months later.

3.3.2.2 Men

The path model for men shows that Time 1 AUDIT scores significantly predicted Time 2 DAS scores ($b = .11$, $p = .02$). Time 3 DAS scores significantly predicted Time 4 BDI-II scores ($b = .08$, $p < .01$). AUDIT scores also significantly directly predicted BDI-II scores six-months-later, from Time 2 to Time 4 ($b = .07$, $p = .03$). The model was also tested from Time 1 to Time 3 to Time 5 separately. This model, ($n = 599$), $\chi^2(16) = 56.56$, $p < .01$, RMSEA = .06, 90% CI (.05, .08), $p < .01$; CFI = .98; TLI = .96; SRMR

= .04, fit the data well. In contrast to the full model, or the women's model, which found a significant path from Time 3 DAS to Time 5 BDI-II over six months, the model with men revealed a significant path from Time 1 AUDIT to Time 3 DAS ($b = .12, p = .02$). No significant indirect or direct effects from AUDIT to BDI-II emerged over one year.

Both men and women demonstrated direct paths from alcohol use to depressive symptoms over six-month paths. Significant paths emerged from alcohol problems to dysfunctional attitudes and from dysfunctional attitudes to depressive symptoms over three months in models with both men and women, again at different times.

3.3.3 AUDIT Subscales

Due to concerns regarding the psychometric validity of the AUDIT subscales, results from the specific subscales of the AUDIT were not emphasized in this dissertation. The findings from the AUDIT subscales are presented in Appendix F. For the same reason, moderated mediation analyses were not conducted with the subscales.

3.4 Results for the Path Model from RAPI to BDI-II

The initial model (*Figure 8*) for this longitudinal analysis ($n = 1090$) shows poor fit, RMSEA = .12, 90% CI (.10, .11), $p < .01$; $\chi^2(67) = 896.38, p < .01$; CFI = .89; TLI = .84; SRMR = .10. All autoregressive paths were significant at the $p = .01$ level. In this model, a significant path from Time 3 RAPI to Time 4 DAS emerged ($b = .09, p = .02$) and a negative path emerged from Time 4 RAPI to Time 5 DAS ($b = -.10, p = .02$). A direct path from Time 2 RAPI to Time 4 BDI-II emerged ($b = .07, p = .01$), as well as a path from Time 2 DAS to Time 3 BDI-II ($b = .06, p < .01$) and from Time 3 DAS to Time 4 BDI-II ($b = .07, p = .01$). The model was also tested from Time 1 to Time 3 to Time 5 separately. This model, ($n = 1090$), $\chi^2(16) = 121.76, (p < .01)$, RMSEA = .08,

90% CI (.07, .09), $p < .01$; CFI = .97; TLI = .93; SRMR = .05, fit the data reasonably well. A significant direct path from Time 1 RAPI to Time 5 BDI-II emerged ($b = .07$, $p = .01$). Therefore, there is evidence from the whole model that alcohol problems predict depressive symptoms over six-months and one year (Figure 8).

Three-month paths.

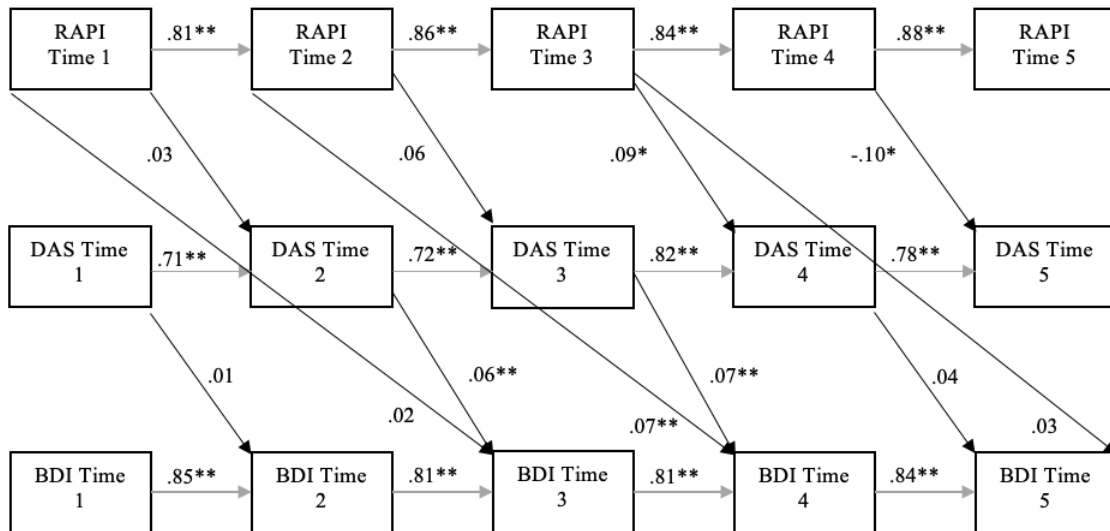

Six-month paths.

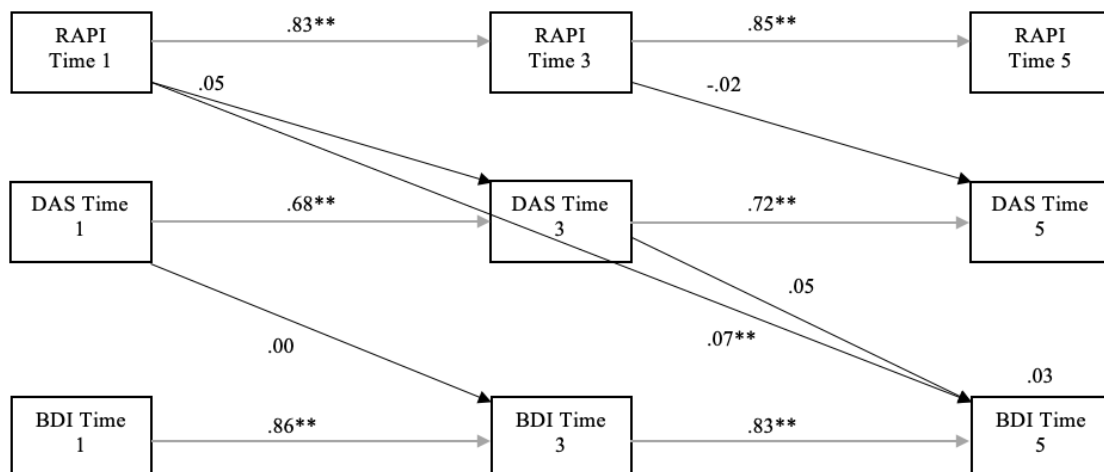

Figure 8. Longitudinal path models from alcohol problems (RAPI) to depressive symptoms (standardized coefficients).

3.4.1 Moderated Mediation Analyses

The full model was tested with both women and men separately. The model fit for women was poor, $n = 491$, $RMSEA = .11$, 90% CI (.10, .12), $p < .01$; $\chi^2(67) = 473.15$, $p < .01$; CFI = .89; TLI = .84; SRMR = .09. The model fit for men, $n = 599$, $RMSEA = .12$, 90% CI (.11, .12), $p < .01$; $\chi^2(67) = 598.54$, $p < .01$; CFI = .87; TLI = .81; SRMR = .10 was also poor. The same pattern of findings as emerged in the whole model, emerged for women's model in both the 3-, 6-, and 12-month paths. There were significant paths from alcohol problems to dysfunctional attitudes, from dysfunctional attitudes to depressive symptoms (over 3 months) and from alcohol problems to depressive symptoms over six months and one year. The path model for men had similar three-month and a six-month path from alcohol problems to depressive symptoms. In the model with six-month and one-year paths, only a path from alcohol problems to dysfunctional attitudes over six months emerged. No year-long direct path emerged for men.

3.4.2 Results from RAPI Subscales

3.4.2.1 RAPI Social/Occupational Consequences

The Social/Occupational Consequences subscale of the RAPI (*Figure 9*) assessed the consequences of problematic drinking, such as going to work intoxicated, experiencing financial difficulties due to alcohol, getting into fights, and neglecting responsibilities. The model fit for this subtest was poor, $RMSEA = .11$, 90% CI (.10, .12), $p < .01$, $\chi^2(67) = 926.85$, $p < .01$; CFI = .88; TLI = .82; SRMR = .10.

Three-month paths.

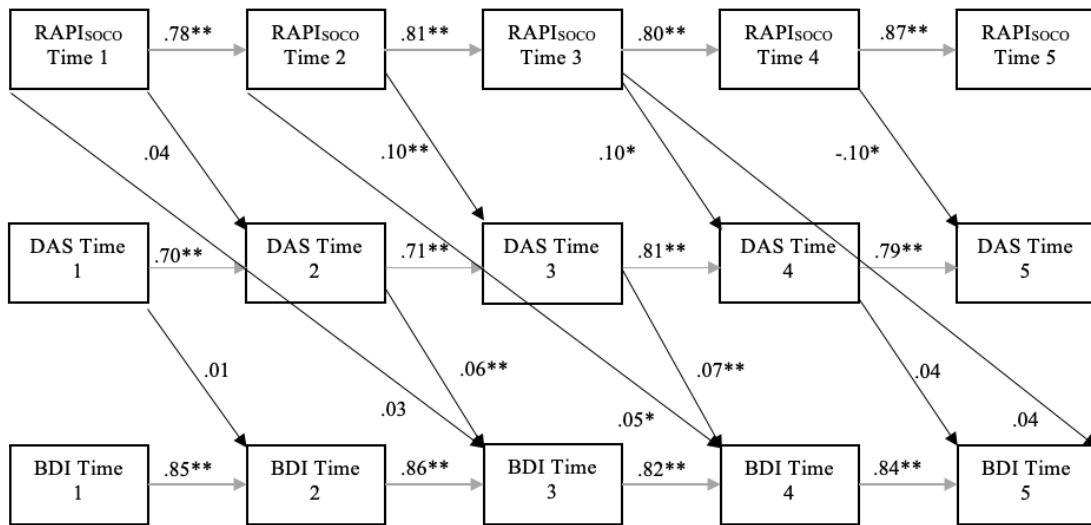

Six-month paths.

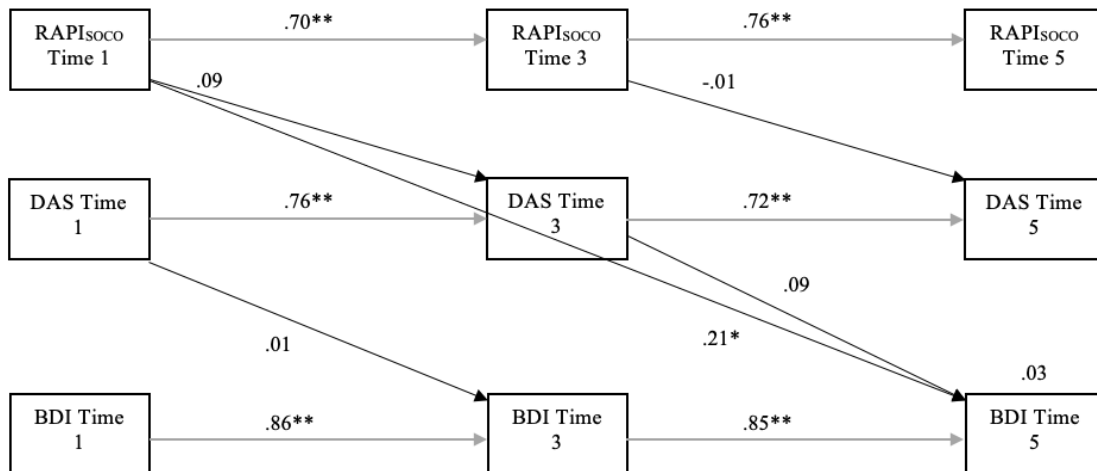

Figure 9. Cross-lagged paths from alcohol problems (social/occupational consequences subscale) to depressive symptoms, three-month and six-month paths.

A review of the standardized regression coefficients for cross-lagged paths indicated that Time 2 RAPI_soco scores significantly directly predicted Time 4 BDI-II scores ($b = .05, p = .05$), Time 2 RAPI_soco significantly predicted Time 3 DAS scores ($b = .10, p = .01$), Time 3 RAPI_soco significantly predicted Time 4 DAS scores ($b = .10,$

$p = .02$), and Time 4 RAPI_soco significantly negatively predicted Time 5 DAS scores ($b = -.10, p = .03$). Dysfunctional attitudes at Time 2 also predicted BDI-II scores at Time 3 ($b = .06, p = .01$) and dysfunctional attitudes at Time 3 predicted BDI-II scores at Time 4 ($b = .07, p < .01$).

For the first time, there was a significant indirect effect. The total direct effect from Time 2 RAPI_soco to Time 4 BDI-II was $b = .06, p = .03$, and the total indirect effect was, $b = .01, p = .05$. This indirect effect accounted for 10% of the variance in the total effect. The model was also tested from Time 1 to Time 3 to Time 5 separately. This model, ($n = 1090$), $\chi^2(16) = 123.43, (p < .01)$, RMSEA = .08, 90% CI (.07, .09), $p < .01$; CFI = .96; TLI = .92; SRMR = .05, fit the data very well. The only significant path was a direct path from Time 1 RAPI_soco to Time 5 BDI-II ($b = .21, p < .01$).

3.4.3 Moderated Mediation Analyses with RAPI, Social/Occupational Consequences Subscale

The model fit for both men [$(n = 599)$, $\chi^2(67) = 623.80, (p < .01)$, RMSEA = .12, 90% CI (.12, .13), $p < .01$; CFI = .86; TLI = .78; SRMR = .11] and women [$(n = 491)$, $\chi^2(67) = 465.42, (p < .01)$, RMSEA = .11, 90% CI (.10, .12), $p < .01$; CFI = .89; TLI = .83; SRMR = .10], was poor in the three-month time-lagged models. Neither model revealed any direct or indirect effects from alcohol problems to depressive symptoms. For women, only the paths from Time 4 RAPI_soco to Time 5 DAS ($b = -.13, p = .01$) and from Time 2 DAS to Time 3 BDI-II ($b = .10, p < .01$) were significant. Among men, the path from Time 2 RAPI_soco to Time 3 DAS ($b = .11, p = .04$) and from Time 3 DAS to Time 4 BDI-II ($b = .10, p < .01$) were significant.

This model was also tested for both men and women with six-month time-lagged paths. For men (*Figure 10*), the model fit was excellent, ($n = 599$), $\chi^2(16) = 64.26$, ($p < .01$), RMSEA = .07, 90% CI (.05, .09), $p < .01$; CFI = .97; TLI = .94; SRMR = .04. Two significant paths emerged, one from Time 1 RAPI_soco to Time 3 DAS ($b = .12$, $p = .05$), and the second from Time 1 RAPI_soco to Time 5 BDI-II ($b = .11$, $p = .01$). The model for women fit the data reasonably well, ($n = 491$), $\chi^2(16) = 73.59$, ($p < .01$), RMSEA = .09, 90% CI (.07, .12), $p < .01$; CFI = .96; TLI = .91; SRMR = .06. The only significant path that emerged for women was a direct path from Time 1 RAPI_soco to Time 5 BDI-II ($b = .07$, $p = .05$).

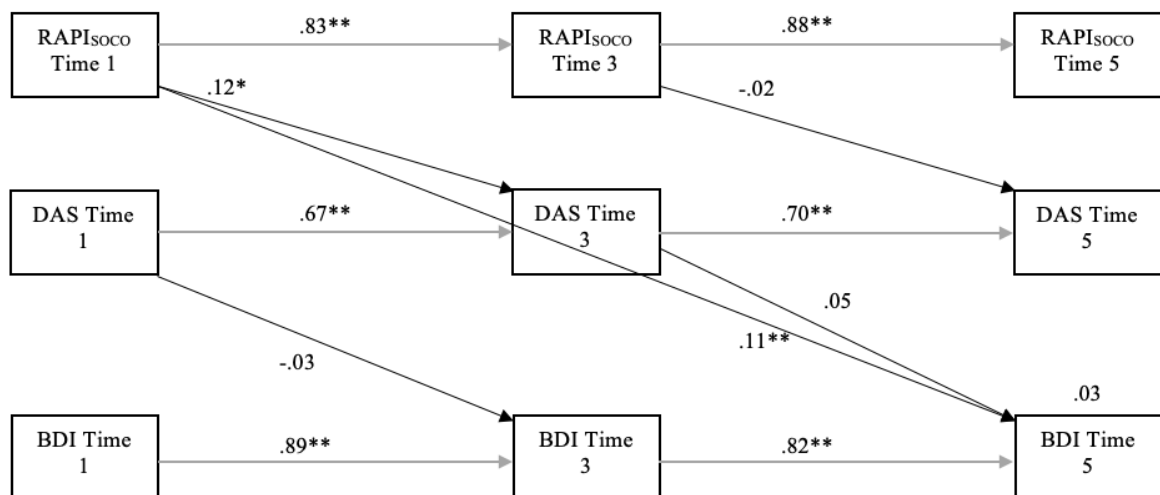

Figure 10. Cross-lagged paths from alcohol problems (social/occupational consequences subscale) to depressive symptoms, six-month paths for men.

Overall, there is more evidence that dysfunctional attitudes play a role in the relationship between the social and occupational consequences of alcohol and depressive symptoms for men over the course of one year, compared to women. There are significant direct paths from the social and occupational consequences of alcohol use to depressive symptoms for both men and women. For men, the relationship between

alcohol problems and dysfunctional attitudes was more consistent, and often positive. For both men and women there is evidence that dysfunctional attitudes predicted changes in depressive symptoms over three-month time frames.

3.4.3.1 RAPI Withdrawal-Dependence

The Withdrawal/Dependence subscale of the RAPI (*Figure 11*) assessed behavioural and physiological consequences of problematic alcohol use, such as passing out from drinking, memory loss, feeling unable to control drinking, and experiencing withdrawal symptoms. The model fit for this subtest was reasonable ($n = 1091$), RMSEA = .11, 90% CI (.10, .12), $p < .01$; $\chi^2(67) = 943.81$, $p < .01$; CFI = .89; TLI = .83; SRMR = .10. A review of the standardized regression coefficients for cross-lagged paths indicates that Time 2 RAPI_wd scores significantly directly predicted Time 4 BDI-II scores ($b = .06$, $p = .01$). Time 3 RAPI_wd significantly predicted Time 4 DAS scores ($b = .08$, $p = .02$) and Time 4 RAPI_wd significantly negatively predicted Time 5 DAS ($b = -.10$, $p = .01$). Time 2 DAS scores significantly predicted Time 3 BDI-II scores ($b = .06$, $p < .01$) and Time 3 DAS scores significantly predicted Time 4 BDI-II scores ($b = .07$, $p = .01$). While there was a significant direct effect from Time 2 RAPI_wd to Time 4 BDI-II, there were no significant indirect effects in this model.

The model was also tested from Time 1 to Time 3 to Time 5 separately (*Figure 11*). This model, ($n = 1090$), $\chi^2(16) = 129.77$, ($p < .01$), RMSEA = .08, 90% CI (.07, .09), $p < .01$; CFI = .96; TLI = .93; SRMR = .05, fit the data very well. In this model, a significant direct path from Time 1 RAPI_wd to Time 5 BDI-II emerged ($b = .06$, $p = .02$), as well as a significant path from Time 3 DAS Time 5 BDI-II ($b = .05$, $p = .02$).

Three-month paths.

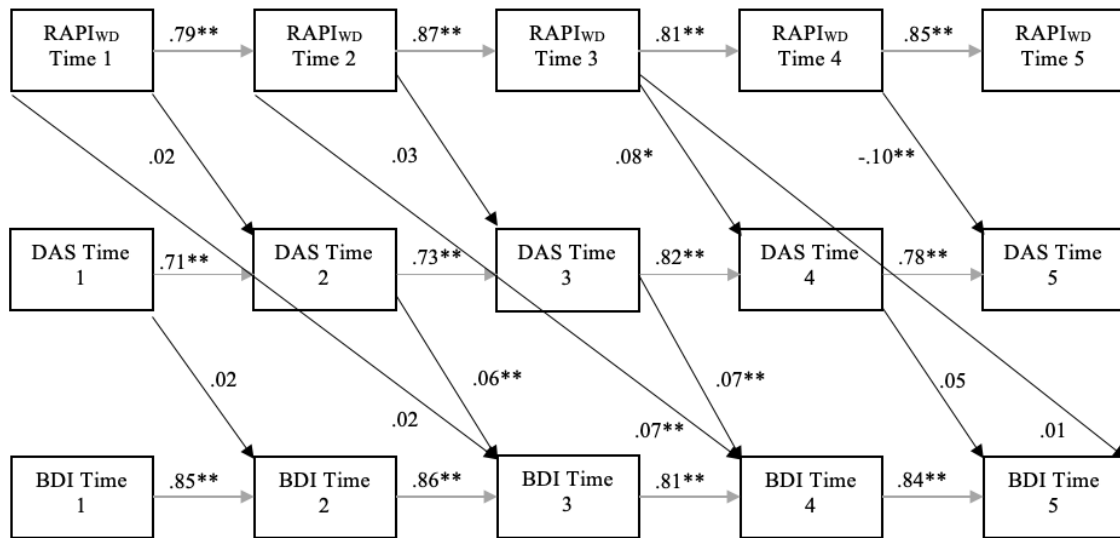

Six-month paths.

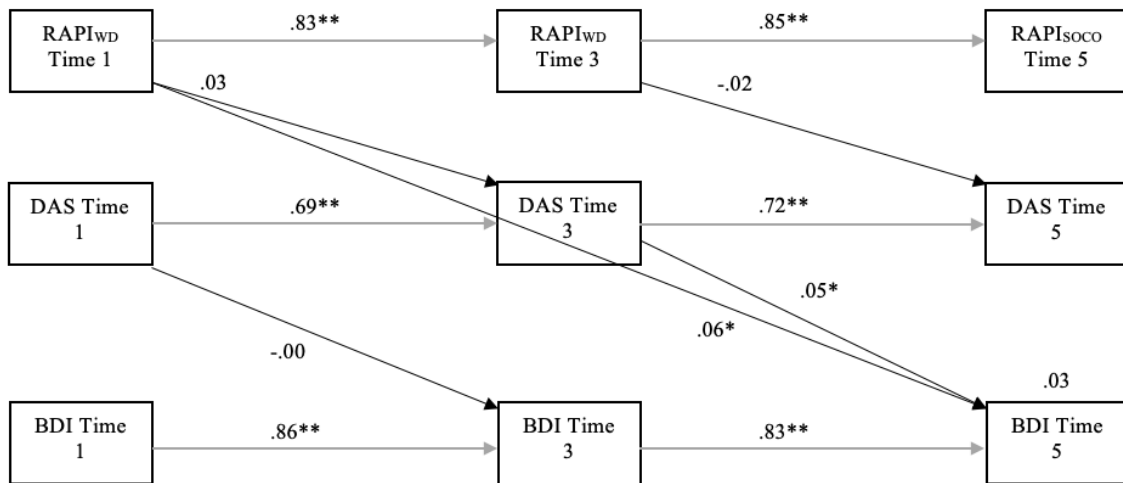

Figure 11. Cross-lagged paths from alcohol problems (withdrawal-dependence subscale) to depressive symptoms, three-month and six-month paths.

3.4.4 Moderated Mediation Analyses with RAPI, Alcohol Dependence and Withdrawal

The hypothesized model for women fit the data poorly, ($n = 491$), $\chi^2(67) = 484.69$, ($p < .01$), RMSEA = .11, 90% CI (.10, .12), $p < .01$; CFI = .89; TLI = .83; SRMR = .10, however many significant paths emerged. Overall, this model was very similar to the model presented above (with all participants included). When the model for women was tested with six-month time-lagged paths only, ($n = 491$), $\chi^2(16) = 80.63$, ($p < .01$), RMSEA = .09, 90% CI (.07, .11), $p < .01$; CFI = .95; TLI = .91; SRMR = .06, the model fit the data better. The only significant path to emerge in this model was a significant path from Time 1 RAPI_wd directly to Time 5 BDI-II ($b = .09$, $p = .01$).

Far fewer significant paths emerged in the men's model, ($n = 599$), $\chi^2(67) = 484.69$, ($p < .01$), RMSEA = .12, 90% CI (.11, .12), $p < .01$; CFI = .87; TLI = .81; SRMR = .10. Among men, none of the paths from RAPI_wd to dysfunctional attitudes emerged. There was one significant path from Time 2 RAPI_wd directly to Time 4 BDI-II ($b = .07$, $p = .04$), and one significant path from Time 3 DAS to Time 4 BDI-II ($b = .10$, $p < .01$). When the model for men was tested with six-month time-lagged paths only, ($n = 599$), $\chi^2(16) = 660.51$, ($p < .01$), RMSEA = .07, 90% CI (.06, .09), $p = .02$; CFI = .97; TLI = .94; SRMR = .04, the model fit the data very well. For men, no significant paths emerged in this model.

Chapter 4

4 Conclusions from the Community Study

It is useful at this point to return to the original hypotheses of this study. The cross-sectional hypotheses were that alcohol problems and depressive symptoms will be significantly correlated with each other, and dysfunctional attitudes will account for a significant proportion of the variance of this relationship across time points. This hypothesis was supported. **Cross-sectional analyses revealed a significant positive relationship between alcohol problems, dysfunctional attitudes, and depressive symptoms at each time point.** Further, **dysfunctional attitudes significantly mediated this effect** and accounted for between 17-33% of the overall relationship between alcohol problems and depressive symptoms.

There were also hypothesized moderated mediation effects, whereby the cross-sectional mediation model proposed above would be significantly moderated by sex; such that the indirect effect would be stronger for women compared to men. This hypothesis was also supported, as **the indirect effect of dysfunctional attitudes on the relationship between alcohol problems and depressive symptoms was 11% for men and 40% for women.**

The first set of longitudinal hypotheses proposed that alcohol problems would predict dysfunctional attitudes over time. The models with the AUDIT demonstrated some, inconsistent, evidence that problematic drinking predicted dysfunctional attitudes three months later. Of note, Hazardous drinking (see Appendix F), specifically, did not predict dysfunctional attitudes at any future time point. Therefore, the direct physical effects of increased alcohol intake did not influence cognitive processes over time (after

three or six months). There was more evidence that alcohol problems (based on the RAPI) predicted dysfunctional attitudes three months and six months later. **Thus, there was evidence to support the hypothesis that alcohol problems predict dysfunctional attitudes.**

Women and men displayed separate patterns, however, **there was more evidence that the social and occupational consequences of alcohol predict dysfunctional attitudes among men, compared to women, and more evidence that alcohol dependence and withdrawal predicted dysfunctional attitudes for women, compared to men.** Therefore, for women, there may be more of a direct physiological response to alcohol dependence and withdrawal that is influencing distorted cognitive processes over time. For men, the difficulties caused by problematic alcohol use may influence their thinking patterns, perhaps as a means of justifying their continued alcohol use.

There were also longitudinal hypotheses positing that dysfunctional attitudes would predict depressive symptoms over time. There was some evidence, over three-month and six-month periods, that dysfunctional attitudes predicted later depressive symptoms for the whole sample when the model employed the AUDIT as the predictor. There was little evidence that sex moderated this finding. A similar pattern was found when the RAPI was employed as the predictor, although no six-month paths emerged in any of these models. The model with the dependence/withdrawal subscale of the RAPI offered the most evidence that dysfunctional attitudes predicted depressive symptoms. **Therefore, there was support for the hypothesis that dysfunctional attitudes predict depressive symptoms over time.**

Direct longitudinal paths from alcohol problems to depressive symptoms were also hypothesized. Direct paths emerged from overall alcohol problems (AUDIT) as well as hazardous and harmful drinking to depressive symptoms, over six-month periods. There were no direct paths present for alcohol dependence and withdrawal. There were no major sex differences in these findings. Direct longitudinal paths also emerged in the models which included the RAPI. For both women and men, alcohol problems directly predicted depressive symptoms six months later. For women, but not men, there was also a direct significant path from alcohol problems to depressive symptoms one year later. **Although inconsistent, there is evidence to support the hypothesis that changes in alcohol problems directly predict changes in depressive symptoms over time, and alcohol problems may have a longer-term influence on depressive symptoms for women compared to men.** When assessing the social and occupational consequences and alcohol dependence and withdrawal separately, **there was a stronger direct effect from the social and occupational consequences of alcohol to depressive symptoms for men compared to women (although both direct paths were significant), and a stronger direct path from alcohol dependence/withdrawal to depression for women (this path was not significant for men).**

The only significant longitudinal indirect effect to emerge across all models was from the social and occupational consequences of alcohol use to depressive symptoms. **Therefore, the hypothesis that dysfunctional attitudes would significantly mediate the relationship between alcohol problems and depressive symptoms does have some support; although it is not consistent across time points and is specific to the social and occupational problems associated with alcohol use.** In this model, dysfunctional

attitudes accounted for 10% of the variance in the total relationship between the social and occupational consequences of alcohol and depressive symptoms over six months. There was no evidence that sex moderated this relationship, as it was only found in the full model, and not in either moderated mediation model. **Therefore, the hypothesis that the indirect longitudinal effect would be stronger for women compared to men, was not supported.**

Although many of the proposed hypotheses were supported to some extent, the lack of consistent findings in the hypothesized directions warrants an exploration of alternative models. The following section will empirically test the Self-Medication Hypotheses; whereby depressive symptoms lead to alcohol problems. Again, this model will test dysfunctional attitudes as a mediating variable, as dysfunctional attitudes should theoretically motivate individuals to seek less productive and helpful coping strategies, such as drinking (Cannon et al., 1999; Gjestad et al., 2011) to manage their depression, and may lead to more stress generation (Liu & Alloy, 2010) in the form of drinking-related problems (e.g., drinking at work, fights with relatives). The same longitudinal models above were tested in the following chapter, with the paths going in the opposite direction (from BDI-II to alcohol problems based on the AUDIT and the RAPI).

Chapter 5

5 Testing Alternative Models: The Self-Medication Hypothesis

In this chapter, the methodology from the previous chapter was replicated, and all models were re-tested with paths going from BDI-II to alcohol problems. Only models using total scores of alcohol measures were tested and no moderated mediation analyses were conducted here, as they are beyond the scope of this dissertation.

5.1 Results for the Path Model from BDI-II to AUDIT

The full model from depression to alcohol use disorder symptoms (AUDIT) demonstrated poor model fit ($n = 1091$), $RMSEA = .11$, 90% CI (.10, .12), $p < .01$; $\chi^2(67) = 956.46$, $p < .01$; $CFI = .90$; $TLI = .84$; $SRMR = .07$. Significant paths emerged from Time 1 BDI-II to Time 2 DAS ($b = .13$, $p < .01$), Time 2 BDI-II to Time 3 DAS ($b = .12$, $p < .01$), and Time 3 BDI-II to Time 4 DAS ($b = .17$, $p < .01$). There was also one significant path from Time 2 DAS to Time 3 AUDIT ($b = .04$, $p = .04$). There were no direct relationships from depressive symptoms to alcohol problems. No indirect effects emerged (*Figure 12*).

The model tested with six-month paths fit the data much better, ($n = 1091$), $RMSEA = .08$, 90% CI (.06, .09), $p < .01$; $\chi^2(16) = 116.23$, $p < .01$; $CFI = .97$; $TLI = .94$; $SRMR = .03$. The paths from Time 1 BDI to Time 3 DAS ($b = .12$, $p < .01$) and from Time 3 BDI to Time 5 DAS ($b = .13$, $p < .01$) were both significant, indicating that depressive symptoms significantly and consistently predicted dysfunctional attitudes over time. There were no direct or indirect paths from depressive symptoms to problematic drinking (*Figure 12*).

Three-month paths.

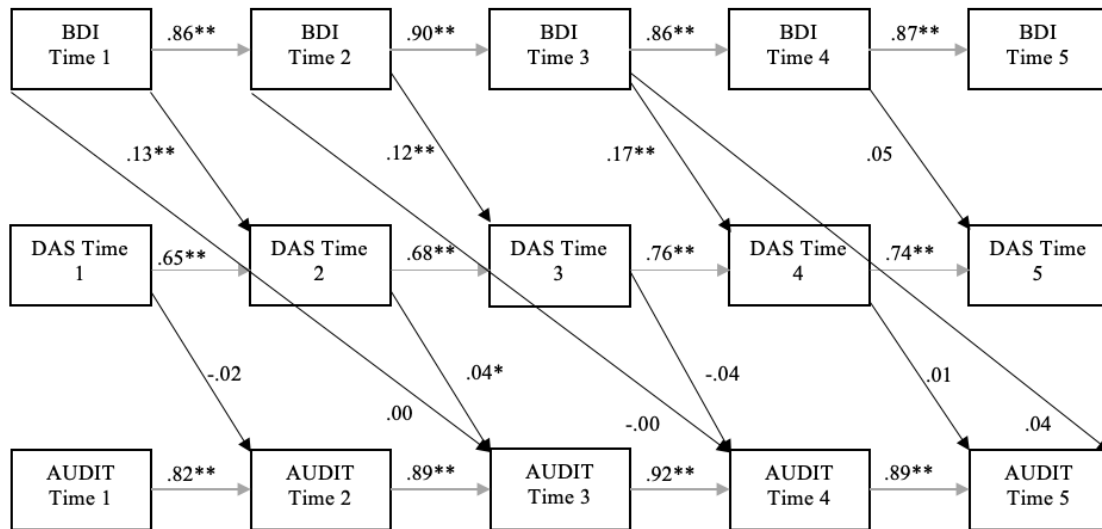

Six-month paths.

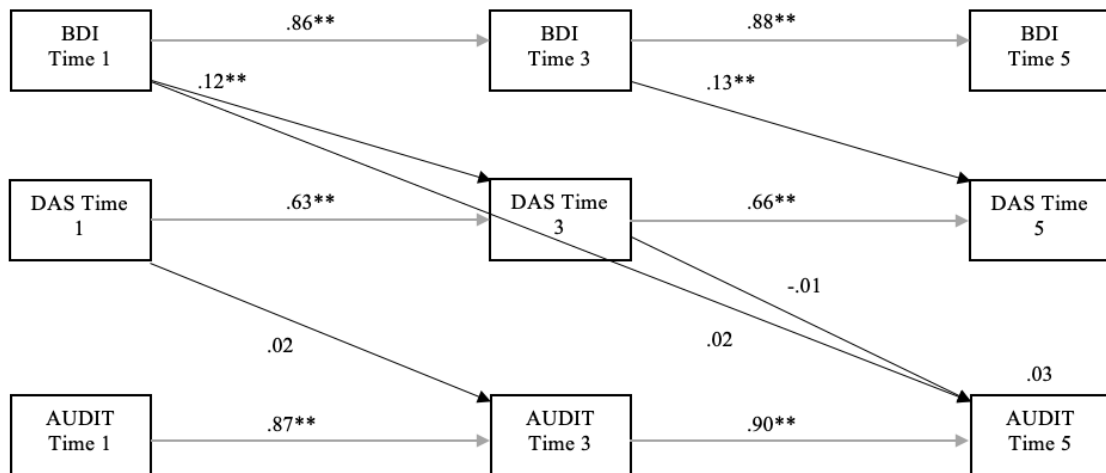

Figure 12. Alternative models from depression to alcohol use disorder symptoms, three-month and six-month paths.

Findings from the AUDIT subscales are presented in detail in Appendix F. The overall model revealed that depressive symptoms consistently and significantly predicted dysfunctional attitudes over three-and-six-month time intervals. There was evidence that dysfunctional attitudes predicted alcohol problems, but this finding only emerged in the model with AUDIT total, alcohol dependence and withdrawal and harmful drinking.

There was also a significant path from dysfunctional attitudes to alcohol dependence and withdrawal six months later, but this path did not emerge in any other models. Findings from the subscales (Appendix F) also indicated a significant direct path from depressive symptoms to harmful drinking. No other direct paths emerged in any of the alternative models. This significant path from depressive symptoms to harmful drinking suggests that depressive symptoms may influence the consequences of alcohol use, which is explored in more detail next.

5.2 Alternative Model from BDI-II to RAPI

5.2.1 Results for the Path Model from BDI-II to RAPI

The hypothesized three-month, cross-legged model from depressive symptoms to alcohol problems (RAPI) poorly fit the data, ($n = 1091$), $RMSEA = .12$ 90% CI (.10, .11), $p < .01$; $\chi^2(67) = 869.92$, $p < .01$; $CFI = .89$; $TLI = .84$; $SRMR = .08$, however many significant paths emerged (*Figure 13*). In this model, significant paths emerged from Time 1 BDI-II to Time 2 DAS ($b = .13$, $p < .01$), Time 2 BDI-II to Time 3 DAS ($b = .12$, $p < .01$), and Time 3 BDI-II to Time 4 DAS ($b = .16$, $p < .01$). Unlike the model with the AUDIT, there was a direct path from Time 2 BDI-II to Time 4 RAPI ($b = .08$, $p = .02$). There was no evidence that dysfunctional attitudes predicted alcohol problems over time.

The model with six-month time-lagged paths (*Figure 13*) fit the data very well, $n = 1091$, $RMSEA = .07$, 90% CI (.06, .09), $p < .01$; $\chi^2(16) = 105.58$, $p < .01$; $CFI = .97$; $TLI = .94$; $SRMR = .03$. Only paths Time 1 BDI to Time 3 DAS ($b = .12$, $p < .01$) and from Time 3 BDI to Time 5 DAS ($b = .13$, $p < .01$) were significant, indicating that depressive symptoms significantly and consistently predict dysfunctional attitudes over

time. There were no direct or indirect paths from problematic drinking to depressive symptoms. Similar patterns emerged on each of the subscales.

Three-month paths.

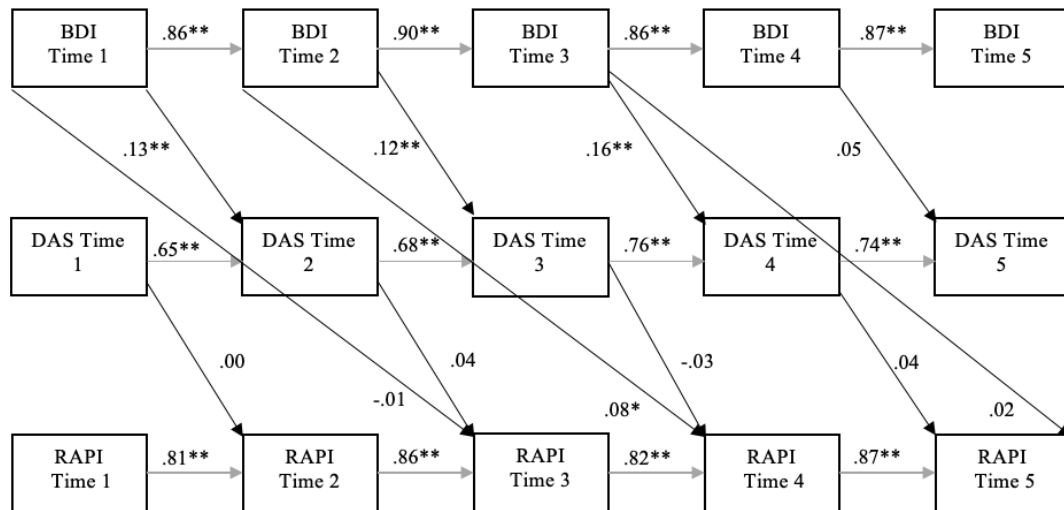

Six-month paths.

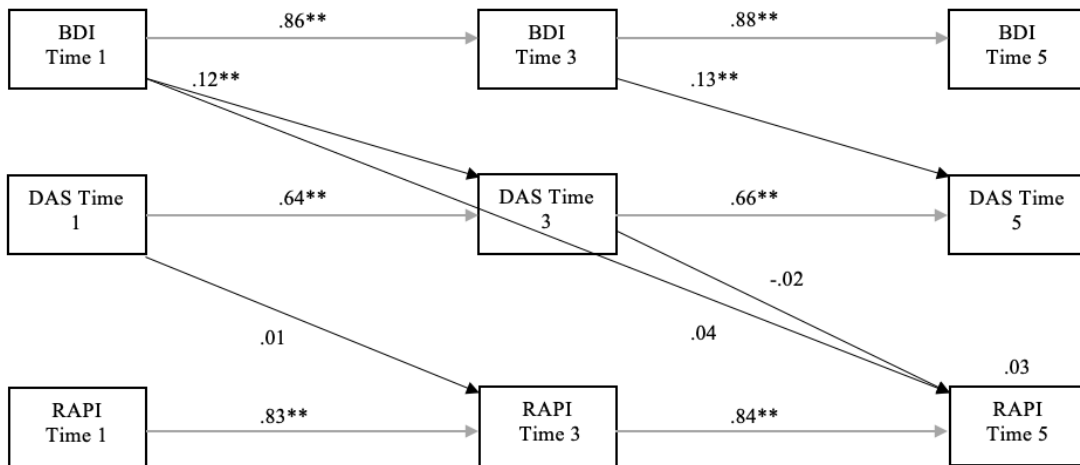

Figure 13. Alternative models from depressive symptoms to alcohol problems, three-month and six-month paths.

5.2.2 Summary of Findings from the Alternative Model from BDI-II to RAPI

Consistent with the findings from the paths using the total score of the AUDIT, depressive symptoms consistently and significantly predicted dysfunctional attitudes over

three-and-six-month time intervals. There was little evidence that dysfunctional attitudes predicted alcohol problems, and little evidence of a direct path from depression to alcohol problems. Therefore, there is far more evidence that depression predicts dysfunctional attitudes and far more evidence from Chapter 3 of a direct relationship from alcohol problems to depression, than from depression to alcohol problems.

Chapter 6

6 Conclusions from the Alternative Model

The “self-medication” model (Khantzian, 1997; K. L. Tomlinson et al., 2006; Weiss et al., 1992), as hypothesized in the literature, suggests that individuals with depression will consume alcohol as a coping strategy to manage and/or avoid their depressive symptoms and the stressful events around them. Not only does the path from alcohol problems to depressive symptoms fit the data better than the path from depressive symptoms to alcohol problems, but no data from this study support the conjecture that increases in symptoms of depression predict increases in drinking frequency or amount (for example, as indicated by the AUDIT hazardous subscale). Rather, this model offers some evidence that increases in depressive symptoms lead to greater drinking problems, such as neglecting responsibilities, getting into fights because of drinking, or showing up to work intoxicated over six months.

It may be that, for individuals who already consume alcohol, depressive symptoms are leading to more problematic behaviours while intoxicated. These findings are consistent with previous research showing that negative life events, while having a significant impact on depressive symptoms, tend not to change drinking habits (Skaff, Finney, & Moos, 1999) and that depressive symptoms, in general, tend not to affect alcohol consumption habits (Allan & Cooke, 1985; Boden & Fergusson, 2011; Fergusson et al., 2009). The model tested in Chapter 3 offered some evidence that dysfunctional attitudes predicted depression over time, although there was much more consistent evidence that depressive symptoms predicted changes in dysfunctional attitudes. While there may be a cyclical relationship between these two variables, there is far more

consistent evidence that depressive symptoms cause changes in dysfunctional attitudes over time, than any other possible relationship.

There is evidence in the literature that cognitive distortions predict subsequent alcohol consumption (e.g., Gjestad et al., 2011) and that dysfunctional attitudes predict depressive symptoms (Rush, Weissenburger, & Eaves, 1986; Zuroff, Blatt, Sanislow III, Bondi, & Pilkonis, 1999; Zuroff, Igreja, & Mongrain, 1990). Testing a third variable hypothesis, whereby dysfunctional attitudes would predict both depressive symptoms and alcohol problems over time, would be a reasonable next step if there were evidence from Chapters 3 and 5 that dysfunctional attitudes significantly predicted either depressive symptoms or alcohol problems. There is very little evidence that dysfunctional attitudes predict either, and therefore there is insufficient data to warrant proposing and testing the third variable hypothesis that dysfunctional attitudes predict both depressive symptoms and alcohol problems.

Chapter 7

7 Study Two: The Student Study

The objective of this study was to replicate the major findings of the first study with a younger population, in a shorter time frame, and to extend the findings to other cognitive tasks. The Community Study investigated dysfunctional attitudes, as they are both easily assessed in an online study, and have a wider representation in the MDD and AUD literatures compared to other cognitive variables. Other cognitive processes, such as ruminative thinking (patterns of thinking that involve a persistent and passive focus on one's distress), and negatively-biased information processing have almost exclusively been studied within the context of mood disorders. In several studies assessing these processes, individuals with comorbid MDD and AUD were actually excluded from participation (e.g., Derry & Kuiper, 1981; Dobson & Shaw, 1987a), presumably because alcohol was not the focus of the study, but was assumed to significantly influence these variables.

More recent studies have begun to investigate how alcohol influences these variables and studies have shown that problem drinking is associated with higher levels of rumination compared to social drinking, and that the link between rumination and problematic drinking behaviours persists after controlling for levels of depression (Caselli et al., 2008). Further, ruminative thinking patterns have been shown to differentiate between problem drinkers and social drinkers, suggesting that the presence of ruminative thinking among individuals who consume alcohol is associated with increased psychopathology (Caselli et al., 2010).

Alcohol intoxication and prolonged alcohol use have also been repeatedly associated impairments in information processing (Hull & Reilly, 1986). Research data show that the encoding of verbal and visual information is poorer among intoxicated individuals compared to individuals who are sober, however the recall of verbal and visual information that is learned under sober conditions is unaffected by alcohol intoxication (Hull & Reilly, 1986). Further, alcohol appears to have a dose-related effect on information processing, as moderate drinkers perform worse on information processing tasks than light drinkers and heavy drinkers perform worse than moderate and light drinkers (Hull & Reilly, 1986).

Women are particularly susceptible to alcohol-induced impairments in information processing, likely as a result of women's lower threshold for experiencing the physiological effects of alcohol compared to men (which were shown in Chapter 3 to have a stronger relationship with depression among women). During periods of low mood, it is highly likely that alcohol would facilitate negatively-biased information processing, especially among women, and would contribute to the onset of a depressive episode. It is unclear whether these information processing deficits occur when individuals are not actively intoxicated, or what the directionality of this relationship is.

No studies to the author's knowledge have assessed the relationship between depressive symptoms, alcohol problems, and either ruminative thinking or negative information processing bias over time. Derry and Kuiper (1981) have assessed the stability of self-referent encoding, specifically, and have found that individuals endorse more negative self-referent information compared to positive self-referent information while they are depressed, but that this bias disappears when participants are no longer in a

depressive episode. A better understanding of the ongoing relationship between these variables could shed light on how they may influence each other, and how to approach intervention and prevention strategies among individuals who suffer from both mood and alcohol difficulties. This study also assessed how different motivations for drinking (specifically, drinking to cope with low mood) influenced alcohol problems. Drinking to cope motives were also added into the longitudinal model to assess whether they are able to predict drinking problems over time (elaborated on in Chapter 9). Ethics approval (REB# 108660) was granted by the Research Ethics Board at the University of Western Ontario.

7.1 Cross-sectional Hypotheses

- (1) Individuals with higher levels of alcohol problems will experience higher levels of depressive symptoms at each time point;
- (2) Distorted cognitions (e.g., dysfunctional attitudes, negatively-biased information processing, rumination) will mediate the relationship between alcohol problems and depressive symptoms at each time point.

7.2 Longitudinal Hypotheses

- (1) Individuals with higher baseline drinking problems will experience higher levels of distorted cognitive processes and depressive symptoms at Time 2 (after controlling for baseline levels of distorted cognitive processes and depressive symptoms).
- (2) Individuals with higher baseline distorted cognitive processes will experience higher levels of depressive symptomatology at Time 2 (after controlling for baseline levels of depression).

(3) Distorted cognitive processes (ruminative thinking, dysfunctional attitudes, negative information processing bias) will mediate the relationship between alcohol problems and depressive symptoms;

(4) Drinking to cope will predict alcohol problems over time (Chapter 9);

Numerous empirical studies suggest that women are more susceptible to experiencing biased information processing as a result of alcohol use and are two times more vulnerable to experiencing depression compared to men (Butler & Nolen-Hoeksema, 1994; Gotlib & Hammen, 2014; Lopez, Driscoll, & Kistner, 2009). Therefore, the moderated mediation hypothesis is that;

(5) The positive causal relationship between alcohol use, negative information processing bias, and depression will be stronger for women compared to men.

7.3 Methods

7.3.1 Design

This study employed a longitudinal design with two waves of data collection (*Figure 14*). All participants completed both time points between two and three months apart. All participants were administered the same measures at both time points. This two-wave method of longitudinal mediation has been supported as robust at detecting indirect effects, despite lacking a third wave (Cole & Maxwell, 2003). Cole and Maxwell (2003) suggest that, as long as baseline levels of the variables are controlled for (which they are in the proposed model), meaningful interpretations of indirect and direct effects can be made.

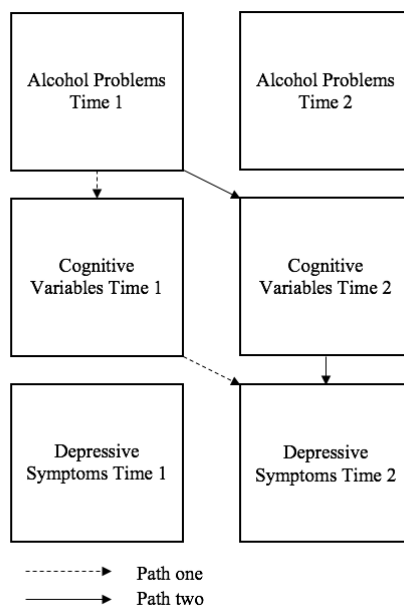

Figure 14. The two possible mediation pathways for the student sample longitudinal analyses.

7.3.2 Sample

Three hundred and twenty-one adult participants were recruited through the Psychology Research Participation Pool at the University of Western Ontario. This sample size has previously been found to be adequate in detecting correlational and predictive associations between cognitive distortions and depression among university students (Craighead, Sheets, Craighead, & Madsen, 2011; K. A. Johnson, Johnson, & Petzel, 1992). Participants were 17 years of age or older, fluent in English, and enrolled in a course that required research participation as part of course credit.

According to the 2018 Canadian Statistics Canada Census data (<https://www150.statcan.gc.ca/n1/pub/91-215-x/91-215-x2018001-eng.htm>), the student sample (see *Table 5*) had a disproportionate number of women (74.9% vs. 50.7% in the Canadian general population), Asian participants (44.2% vs 19% in the Canadian general

population), single people (86.3% vs. 28% in the Canadian general population), young adults (84.1% vs 7% in the Canadian general population), and people with some post-secondary education (89.4% vs 60.7% in the general populations). There were also fewer white participants (44.5% vs. 65% in the Canadian general population).

While it is useful to compare this sample with the sample to which the results from this study are being generalized (i.e., a North American population), it may also be useful to appreciate how this sample compares to the general undergraduate population. The Association for Universities and Colleges of Canada last reported the demographic information for post-secondary populations in 2011 (The Association of Universities and Colleges of Canada, 2011). Overall, the present sample had more individuals under the age of 24 (97.8 compared to 75.9% in general post-secondary samples) and more women (74.9% vs. 57.5%).

No information about the ethnic distribution of undergraduate students was available, only 8% of students in the general Canadian post-secondary population are international. Therefore, given that the present sample is predominately comprised of White and Asian participants, it is possible that this sample has more international students from countries with White and Asian ethnic backgrounds (e.g., China and Europe) compared to the general undergraduate population. No information about the marital status of students in the general Canadian undergraduate population was available.

Table 5. Demographic Statistics for the Student Sample

	Age (%)	Sex (%)	Ethnicity (%)	Marital Status (%)	Education (%)
Time 1 <i>N</i> = 321	<18 (13.71)	Male (25.12)	White (44.53)	Single (86.30)	High school (.60)
	18-24 (84.11)	Female (74.78)	Hispanic (.90)	Committed relationship (12.50)	Some College (89.41)
	25-34 (1.22)	Other (.00)	African Canadian (1.61)	Married/common law (1.29)	Trade School (5.60)
	35-44 (.30)		Native Canadian (.90)	Widowed (.00)	Associates (.30)
	45-54 (.00)		Asian (44.22)	Divorced (.00)	Bachelor (.30)
	55-64 (.32)		Middle Eastern (4.71)	Separated (.00)	Master's (3.71)
	65-74 (.28)		Mixed Race (.92)		Professional (.00)
	75+ (.00)				PhD (.00)
Time 2 <i>N</i> = 212	<18 (4.9)	Male (24.00)	White (46.2)	Single (83.51)	High school (1.41)
	18-24 (58.6)	Female (76.00)	Hispanic (.90)	Committed relationship (14.67)	Some College (87.30)
	25-34 (.90)	Other (.00)	African Canadian (1.40)	Married/common law (1.92)	Trade School (6.12)
	35-44 (.30)		Native Canadian (.50)	Widowed (.00)	Associates (.50)
	45-54 (.00)		Asian (43.40)	Divorced (.00)	Bachelor (.00)
	55-64 (.30)		Middle Eastern (4.21)	Separated (.00)	Master's (4.71)
	65-74 (.30)		Mixed Race (3.29)		Professional (.00)
	75+ (.00)				PhD (.00)

Note: Some students endorsed multiple ethnicities, therefore the percentages add to more than 100%. Reporting multiple ethnic origins is common. According to the 2016 Statistics Canada Census, 41.1% of Canadians report more than one ethnic origin.

7.3.3 Measures

All measures from Study 1 (demographic questionnaire, AUDIT, RAPI, BDI-II, Visual Analog Mood Scale, Adapted Velten Mood Induction Procedure, and the DAS) were also included in this study. Additional measures were also included and are outlined below. Reliability analyses were conducted on all measures to determine their level of internal consistency in this student sample. Time 1 reliabilities are presented here.

In this sample, the total score of the BDI-II demonstrated good internal consistency ($\alpha = .89$), and so did the subscales (somatic, $\alpha = .82$; cognitive, $\alpha = .84$). The AUDIT ($\alpha = .83$) also demonstrated good internal consistency, however its subscales demonstrated questionable to acceptable levels of internal consistency (hazardous, $\alpha = .75$; withdrawal/dependence, $\alpha = .58$; harmful, $\alpha = .58$). The overall RAPI scores demonstrated good internal consistency ($\alpha = .88$) and the internal consistency of the subscales was acceptable (social/occupational consequences, $\alpha = .79$; withdrawal/dependence, $\alpha = .76$). Therefore, results from the RAPI were emphasized more than results from the AUDIT, given its superior reliability scores. Reliability analyses were also conducted on the two versions of the DAS. DAS A demonstrated good internal consistency ($\alpha = .82$) and the DAS B demonstrated acceptable internal consistency ($\alpha = .78$).

7.3.3.1 Additional Cognitive Measures

Drinking Motives Questionnaire-Revised (DMQ-R; Cooper, 1994) is a 20-item measure that assesses the four established motives for drinking (i.e., enhancement [5 items; “Because it’s fun”], social [5 items; “To celebrate a special occasion with friends”], conformity [5 items; “To fit in with a group you like”], and coping [5 items;

“To forget about your problems”]. Participants indicate how often they drink for each reason on a 5-point scale from 1 (almost never/never) to 5 (almost always/always). Subscale scores are computed by averaging responses across subscale items. It makes little logical sense to compute the reliability of the total score for this subscale, as the total score on this measure would simply indicate how many motives people endorsed. Therefore, the DMQ-R was divided into its subscales and the findings demonstrated good reliability for the social subscale ($\alpha = .82$), acceptable reliability for the coping ($\alpha = .71$) and conformity subscales ($\alpha = .73$), and questionable reliability for the enhancement subscale ($\alpha = .65$). A confirmatory factor analysis was conducted on the DMQ (based on the Community Study Data) to evaluate the factor structure of this measure (Appendix C). The factor most closely related to its intended subscale was factor two, which aligned closely with coping. Therefore, the coping subscale has the most psychometric validity in this sample. The other factors did not align well with their intended subscales. During the CFA, which was conducted using exploratory analyses, all factors aside from the coping factor significantly overlapped. These pre-determined factors (social, enhancement, and conformity) may not be distinct motivations for drinking (and motivations for drinking may be multifaceted, thus precluding a clear identification of separate motivations during each drinking occasion). For these reasons, analyses focused on the most psychometrically valid subscale, as well as the subscale the most theoretically associated with depressive symptoms and alcohol problems (e.g., Armeli, Conner, Cullum, & Tennen, 2010; Colder, 2001; Foster et al., 2014), which is the coping subscale.

Ruminative Response Scale – 10 item measure (Treynor, Gonzalez, & Nolen-Hoeksema, 2003). This measure is a 10-item self-report questionnaire based on the 22-

item Ruminative Response Scale (Nolen-Hoeksema & Morrow, 1991), which was designed to assess individuals' tendencies to focus attention on their negative affect and distress. Given that many of the items closely overlapped with depressive symptomatology (e.g., "think about how alone you feel"), there were concerns regarding this scale's ability to differentiate rumination from overall depression. Therefore, Treynor and his colleagues (2003) analyzed the items on this questionnaire and designed a 10-item version of the RRS that is not confounded with depression content. The internal consistency of the RRS was acceptable in the present sample ($\alpha = .75$).

Self-referent encoding task. This task is a depth of processing paradigm (Ingram & Reed, 1986), first presented by (Rogers, Kuiper, & Kirker, 1977). Depth-of-processing paradigms present participants with several stimulus adjectives and asks them to rate each adjective on a specific dimension (e.g., semantic, phonemic). In the self-referent encoding task, participants view several stimulus adjectives and rate each adjective based on how much it describes the participant. Once the task is complete, participants are asked to recall as many of the adjectives as possible. This study employed 17 positive and 17 negative self-referent words from the list used in Derry and Kuiper's 1981 study (the original list contained 30 depressed and 30 non-depressed words). In this study, Derry and Kuiper formulated a list of adjectives that specifically representing depressed and non-depressed states, which were balanced in terms of their length (number of letters per word), frequency of use in the English language, and relative emotional valence. Thirty-four of these 60 words were used for the main SRET task, based on their use in other studies with shorter word lists (e.g., Ingram, 1983) and their relative frequency in the English language (<https://www.wordfrequency.info/free.asp?s=y>).

This task is expected to tap into information processing differences among individuals with or without depression as individuals with depression are expected to disproportionately endorse and remember negative information relevant to them, compared to individuals who are not depressed (Derry & Kuiper, 1981; Dobson & Shaw, 1987a; Ingram & Reed, 1986). This task also provided an opportunity to test whether individuals who have more alcohol-related problems process more negative self-referent words than positive self-referent words compared to individuals who have fewer alcohol-related problems.

7.3.4 Scoring the Self-Referent Encoding Task

Studies using the SRET have used a variety of approaches for calculating memory biases; however, the most common approach is to take the number of positive or negative words recalled and endorsed as the numerator and the total number of both positive and negative words endorsed as the denominator (e.g. Hammen & Zupan, 1984; Hayden, Klein, Durban, & Olino, 2006; Prieto, Cole, & Tageson, 1992). This method was used in the present study as it has become the standard in the adult SRET literature, and is preferable because it controls for overall endorsement rates, which have been shown to vary by groups and arbitrarily shift processing scores (Prieto et al., 1992).

The self-referent encoding task required several steps to arrive at the final equation. First, the number of positive and negative words endorsed as “like me” was calculated for each participant, as well as the total number of words endorsed as “like me”. Second, a visual scan was conducted for all words recalled by each participant and any recalled words that were not from the initial list of words to endorse were deleted (e.g., several participants incorrectly recalled words like “hopeful” and “content” that were not on the

original list of words). Any duplicates were also deleted (i.e., some participants recalled the same word multiple times) – possibly pointing to some cognitive deficits that warrant further study. Recalled words that were similar to the initial words (e.g., “energized” instead of “energetic”) were counted as correct. The total number of positive and negative correctly recalled words was calculated, along with the total number of correctly recalled and total number of incorrectly recalled words.

Next, for each word, for each participant, a visual scan was conducted to calculate the number of positive and negative words that were both endorsed and recalled. Thus, the total number of positive endorsed and recalled words and the total number of negative endorsed and recalled words was calculated for each participant. Then, the total number of words recalled and endorsed was calculated and two equations were calculated (1) Total number of positive words endorsed and recalled/Total number of words recalled; (2) Total number of negative words endorsed and recalled/Total number of words recalled (see *Table 6*).

Table 6. Scores on the Self-Referent Encoding Task, Time 1 and 2

SRET Scores	Time 1 <i>M (SD), n = 325</i>	Time 2 <i>M (SD), n = 212</i>
Positive Words Endorsed (out of 17)	12.12 (3.72)	12.06 (4.24)
Negative Words Endorsed (out of 17)	5.04 (4.04)	5.00 (3.69)
Total Words Endorsed (out of 34)	17.16 (3.15)	17.10 (3.71)
Positive Words Recalled	5.85 (2.25)	7.37 (2.27)
Negative Words Recalled	4.06 (2.00)	5.43 (2.31)
Total Words Recalled	9.90 (3.39)	12.81 (3.80)
Positive Words Endorsed and Recalled	4.37 (2.33)	5.37 (2.62)
Negative Words Endorsed and Recalled	1.44 (1.62)	2.12 (1.99)
Total Words Endorsed and Recalled	7.49 (2.81)	5.82 (2.55)

7.3.5 Procedure

Participants received a Letter of Information and Consent (Appendix A) to familiarize themselves with the study. Before participants were administered measures of distorted cognitive processes, they were screened for depressive symptomatology (using the BDI-II). Participants with minimal (scores between 0-13), mild (scores between 14-19), and moderate (scores between 20 and 28) depressive symptomatology were led through a sad mood induction procedure and completed measures of distorted cognitions before and after the induction procedure. Participants who met criteria for severe (scores between 29-63) depressive symptoms were not led through the sad mood induction, but were given measures of distorted cognitive processes. Once the study was over, participants with severe depression were given resources for mental health services. Students received course credit for participating. Participants were led through the study in the following order;

1. Brief demographic questionnaire (5 minutes);
2. Two alcohol use measures (5-7 minutes);
3. A measure of depressive symptomatology (5-7 minutes);
4. Visual Analog Mood Scale to assess current mood (5 seconds);
5. A short-form measure of dysfunctional attitudes (3 minutes);
6. Participants who were not currently depressed were led through a mood induction procedure to induce sad mood (5 minutes). *Participants who were currently severely depressed bypassed this section and proceeded to number 9;*
7. Visual Analog Mood Scale to assess their current mood (5 seconds);
8. A parallel short-form measure of dysfunctional attitudes (3 minutes);

9. Self-referent encoding task (10 minutes);
10. Ruminative Response Scale (5-10 minutes);
11. A recognition task followed by a memory recall task from the SRET (10-15 minutes)
12. Participants who completed the sad mood induction were given one minute to write about something happy that happened in their lives (to ensure that participants are left with positive thoughts; 1 minute).
13. Participants were then given a third Visual Analogue Scale to monitor whether their mood improved following Step 12.
 - a. At Time 2: participants were debriefed.

Total time: approximately 45-70 minutes

7.3.6 Missing Data

A variable named “missingness” was computed for Time 2 to determine whether presence or absence in Time 2 was correlated with measures of interest from Time 1 (e.g., alcohol problems, depressive symptoms, DAS, RRS). No significant correlations were found between “missingness” and any of the variables of interest or any demographic variables at Time 1. Therefore, participants appear to have dropped out of the study for reasons not related to the variables of interest. Unfortunately, approximately one third of individuals did not return for Time 2 of the study, which occurred between eight and 12 weeks following the first time point.

7.3.7 Data Analytic Techniques for Community Sample

7.3.7.1 SPSS Analyses

The following analyses were conducted using SPSS Versions 24 and 25 (IMB SPSS Statistics, 1989-2016; 2017). Cronbach's alpha was computed for all measures and the reliability estimates are presented within the methods section, with each respective measure. Paired Samples t-tests⁴ were employed to examine whether the two versions of the DAS (A and B) were sufficiently similar to be considered parallel, and to determine whether the Velten Mood Induction procedure was successful in increasing dysfunctional attitudes across both time points. That is, the "pre-mood induction" DAS scores were compared to all "post-mood induction" DAS scores. Descriptive statistics and frequency tables were computed for all demographic information, analyses of failing attention checks, and manipulation check questions (see Appendix G).

7.3.8 MPlus Analyses

Path analytic models were tested for all longitudinal hypotheses to determine whether the hypothesized relationships between alcohol variables, cognitive variables, and depression fit the observed data, and whether cognitive variables mediated this relationship. Simpler models were tested separately, and then a more complicated model, whereby latent variables entitled "alcohol problems" (AUDIT, RAPI), "distorted cognitive processes" (RRS, SRET variables, DAS), and "depressive symptoms" (using both subscales of the BDI-II) were created using indicators of those constructs.

⁴ A paired-samples t-test was conducted rather than a chi-squared test because the data for the DAS were normally distributed.

Structural equation models, which included latent and observed variables, were also tested cross-sectionally at both time points. Adding latent variables to the analyses reduces error variance and allows for a more robust analyses of the relationships between variables. Further, latent variables allow for multiple factors of a construct to be included (e.g., the latent variable “alcohol-related problems” can include the information from multiple areas of alcohol use (e.g., frequency, dependence/withdrawal/alcohol-related problems). Models including drinking to cope motivations were conducted separately, following all other analyses.

7.3.9 Data Cleaning and Analysis

A review of the attention checks, outliers, non-normality, and missing data points was conducted for all Student Study data. An analysis of whether the two short-forms of the DAS were equivalent was also conducted and findings indicated that these scales are not comparable. Mood prime data was also analyzed and found evidence that the prime succeeded in activating latent dysfunctional attitudes at Time 1 (see Appendix G).

Chapter 8

8 Results of the Student Study

8.1 Descriptive Statistics

A review of the means and standard deviations suggest that clinical levels of alcohol problems and depressive symptoms were not common in this sample, which would be expected for a student sample. The prevalence of clinically-significant scores on the measures, however, was lower than expected (see *Table 7*).

Table 7. Descriptive Statistics of Time 1 Student Data

Scale	N	M	SD	Skewness	Kurtosis	Min	Max
AUDIT Total	260	8.17	5.90	.12	.81	1	29
Hazardous Dependence	260	4.70	2.69	.83	-1.00	0	11
Harmful	260	.88	1.36	1.89	5.05	0	8
RAPI Total	260	2.58	2.95	1.41	1.61	0	15
RAPI Social/Occupational Dependence/Withdrawal	258	7.26	7.47	1.83	4.32	0	43
	258	3.79	3.99	1.65	1.65	0	21
	260	3.11	3.37	3.20	3.62	0	18
BDI	321	10.55	8.26	1.35	2.31	0	47
Somatic	321	5.86	4.43	1.56	3.01	0	25
Cognitive	321	4.66	4.46	1.24	1.95	0	26
DMQ Social	260	13.82	5.03	-.07	-.89	5	25
DMQ Conformity	260	13.03	3.76	-.25	-.65	5	24
DMQ Enhancement	259	9.87	3.59	.75	.57	5	23
DMQ Coping	260	12.00	3.76	.35	.37	5	25
DAS	321	19.36	4.67	.09	.13	9	33
Negatively-biased Information Processing	317	.08	.09	1.25	1.50	0	.42

Studies using the National Household Survey on Drug Abuse have found that 24% of college men and 13% of college women suffered from clinically significant levels

alcohol-related problems (Slutske, 2005). In this sample, 10 participants (3.1%) endorsed symptoms in the clinically significant range on the AUDIT (20+) and 18 participants (5.6%) endorsed symptoms in the clinically significant range on the RAPI (20+). The prevalence of clinically significant levels of depressive symptoms was also low. While prevalence rates of depression among college students are typically around 11% (Beiter et al., 2015), 10 participants (3.1%) endorsed clinically significant levels on the BDI-II (20+), thus rates of clinically significant depressive symptoms were also lower than expected.

8.1.1 Variability in Alcohol Problems, Dysfunctional Attitudes, and Depressive Symptoms Over One Year

The longitudinal analysis across two time points assessed whether scores on alcohol problems (RAPI and AUDIT), dysfunctional attitudes (DAS), rumination (RRS), information processing (SRET), drinking motives (DMQ-R) and depression (BDI-II) predict future scores on any of these measures, or whether there is significant variability in these variables over time. (*Table 12* in Appendix G provides an overview of the means and standard deviations for the whole sample across time points, and across sexes. Appendix H provides a detailed description of the changes in variables over time). Overall, depressive symptoms, negatively-biased information processing, and conformity motives decreased over time. There were no changes in dysfunctional attitudes or alcohol measures from Time 1 to Time 2. Men had higher levels of alcohol problems on the AUDIT and significantly increased their drinking to cope motives over time, compared to women. Women, overall, had higher levels of ruminative thinking and recalled more positive words compared to men.

8.2 Correlations Between Primary Variables at Time 1

To help better understand how these variables are related to each other in this sample, bivariate correlations were computed for the primary and secondary variables at Time 1 (*Table 8*). A full description of how the variables related to each other is presented in Appendix H. Correlations between primary and secondary variables (e.g., DMQ, other analyses of the SRET) are also outlined in detail in Appendix H in Tables 13 and 14.

Table 8. Correlations Between Primary Variables at Time 1, Student Study

	1	2	3	4	5	6	7	8	9	10	11	12	13	14
1. AUDIT _{Total}	1													
2. AUDIT _{Haz}	.83**	1												
3. AUDIT _{Harm}	.90**	.57**	1											
4. AUDIT _{Dep}	.72**	.40**	.62**	1										
5. RAPI _{Total}	.75**	.55**	.68**	.67**	1									
6. RAPI _{Dep/With}	.70**	.50**	.62**	.67**	.92**	1								
7. RAPI _{SoCo}	.70**	.53**	.65**	.60**	.94**	.74**	1							
8. DAS	.10	.05	.14*	.04	.19**	.14*	.21**	1						
9. BDI-II _{Total}	.22**	.06	.32**	.16*	.36**	.33**	.35**	.47**	1					
10. BDI-II _{Cog}	.20**	.06	.29**	.12*	.29**	.27**	.26**	.47**	.93**	1				
11. BDI-II _{Som}	.21**	.06	.29**	.17**	.39**	.33**	.38**	.40**	.95**	.72**	1			
12. RRS	.05	-.01	.07	.09	.13*	.14*	.10	.31**	.31**	.29**	.28**	1		
13. SRET _{NegativeInfo}	.03	-.01	.07	.01	.03	.02	.03	.34**	.48**	.49**	.40**	.28**	1	
14. DMQ _{Coping}	.50**	.41**	.42**	.41**	.48**	.56**	.43**	.22**	.21**	.20**	.19**	.10	-.08	1

Note: Correlations significant at $p < .05$ are marked with *, and $p < .01$ are marked with **. $N = 260$ (listwise deletion use)

8.2.1 CFA of the Measurement Model

A CFA was conducted to assess the fit of a model whereby Alcohol Problems, Distorted Cognitive Processes and Depressive Symptoms are associated with each other (the correlation matrix is presented in *Table 9*). This measurement model (*Figure 15*) was tested with Time 1, which had the highest power to detect associations between these variables ($n = 318$). The original model fit the data extremely well, $\chi^2(17) = 39.22$, $p < .01$, RMSEA = .06, 90 CI (.04, .09), $p = .17$, TLI = .98, CFI = .96, SRMR = .04 and no modifications were made to the original model. The results of this analysis demonstrate a good fitting measurement model. The standardized loadings are all high, statistically significant, appropriate values and there is no issue with the pattern of correlations.

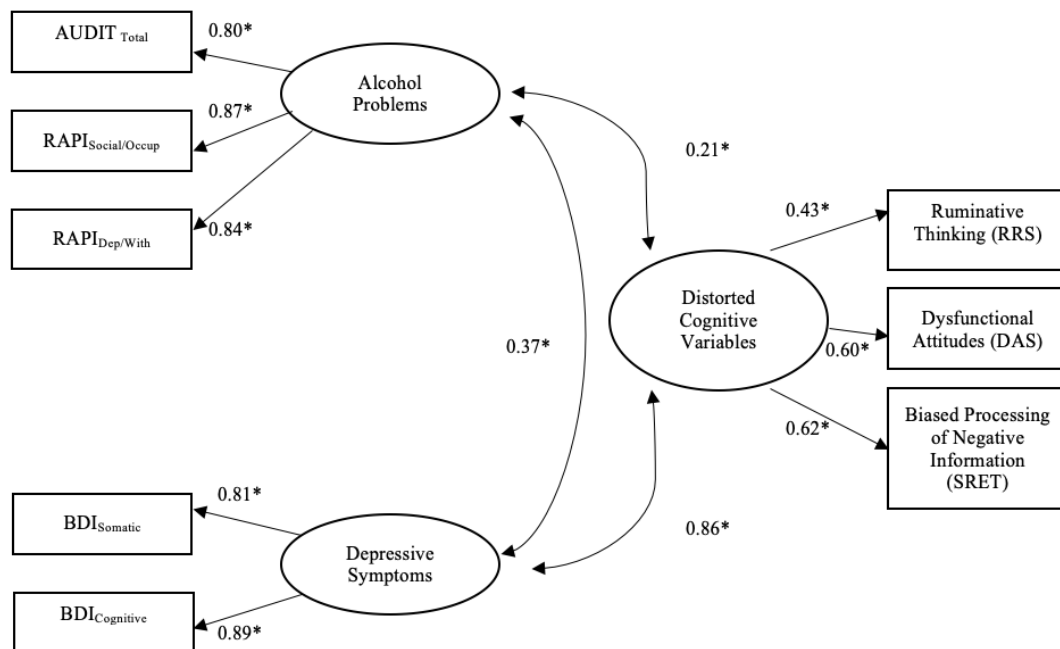

Figure 15. Final cross-sectional measurement model for the student study, time 1 data used.

Table 9. Correlation Table for Measurement Model, Student Study, Time 1 Data Used

Measure	AUDIT Total	RAPI Withdrawal	RAPI Social/ Occup.	DAS	RRS	SRET Negative	BDI Som.	BDI Cog.
AUDIT Total	1							
RAPI Withdrawal	.67**	1						
RAPISocial/ Occup.	.69**	.72**	1					
DAS	.12*	.14*	.21**	1				
RRS	.03	.13*	.09	.30**	1			
SRET Negative	.05	.03	.04	.34**	.28**	1		
BDI Somatic	.20**	.31**	.37**	.41**	.28**	.40**	1	
BDI Cognitive	.19**	.26**	.25**	.48**	.29**	.50**	.72**	1

Note. $N = 318$, Missing data estimated using MLR in MPlus.

8.2.2 Cross-Sectional Structural Equation Model, Time 1.

The structural equation model based on the CFA was conducted with Time 1 data, as this time point had the highest power for detecting effects. The latent variable, Depressive Symptoms, was loaded onto the latent variable, Alcohol Problems and on the latent variable, Dysfunctional Cognitive Processes. The Dysfunctional Cognitive Processes latent variable was included in the model as a mediator between Alcohol Problems and Depressive Symptoms.

The structural model for Time 1 data ($N = 318$) demonstrated excellent fit; $\chi^2(17) = 39.22$, $p < .01$, RMSEA = .06, 95% CI (.04, .09), CFI = .98, TLI = .96, SRMR = .04. All standardized parameters in the final model were statistically significant at the .05 level (Figure 16). Both the total direct ($b = .37$) and total indirect ($b = .17$) effects were

significant ($p < .01$). The size of the direct effect was moderate and the size of the indirect effect was relatively small. The specific direct effect of alcohol problems on depression was significant ($b = .20$, $p < .01$) and dysfunctional attitudes significantly mediated this effect ($b = .17$, $p = .01$, Bootstrapped 95% CI [.04, .30]), accounting for 45.9% of the variance. The size of both the specific direct and specific indirect effects were relatively small, but accounted for a very large proportion of the variance.

Overall, the model fit the data well and suggests that alcohol problems are statistically significantly associated with depressive symptoms, and that dysfunctional cognitive processes partially mediate almost half of this effect. All standardized loadings were significant, positive values, and do not point to any specific concerns with the model.

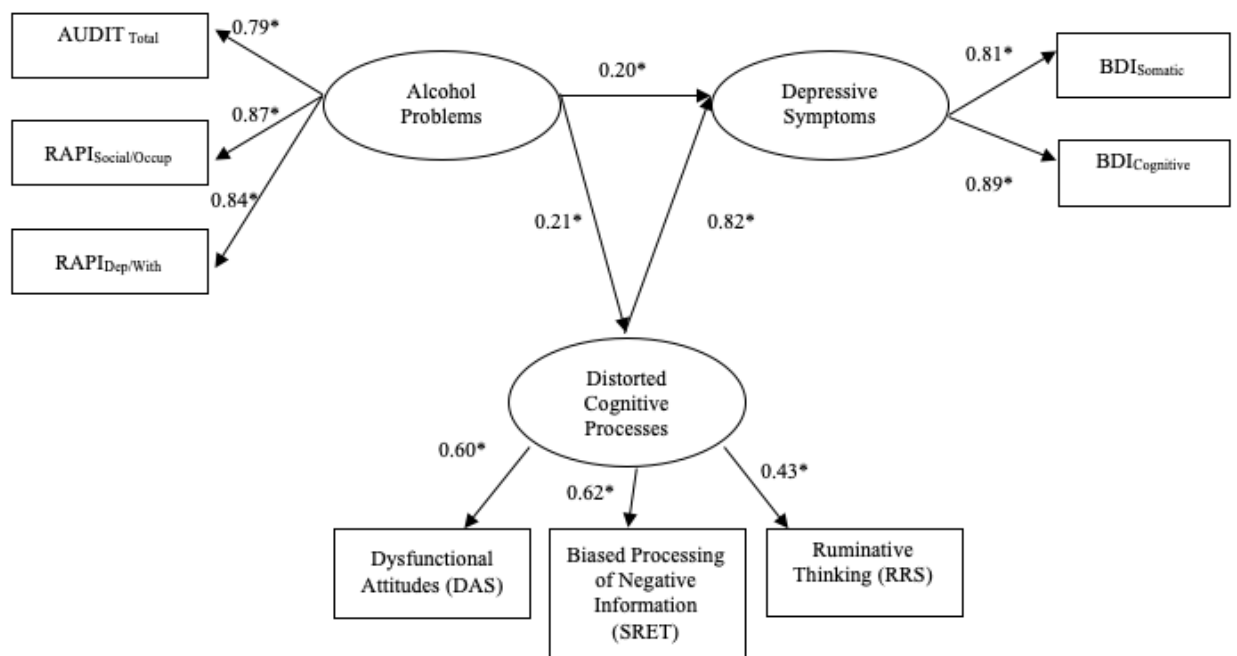

Figure 16. Cross-sectional SEM model for student study, time 1.

8.2.3 Moderated Mediation Cross-Sectional Analyses

The cross-sectional model using Time 1 data was used to test sex differences in the relationship between alcohol problems, dysfunctional attitudes, and depressive symptoms.

8.2.3.1 Women

The structural model for Time 1 data with women ($n = 178$) demonstrated excellent fit; $\chi^2(17) = 33.52, p < .01$, RMSEA = .08, 95% CI (.04, .11), $p = .13$, CFI = .94, TLI = .94, SRMR = .05. The direct path from alcohol problems to depressive symptoms was not significant ($b = .15, p = .22$), and the paths from alcohol problems to distorted cognitive processes ($b = .27, p = .02$), and from distorted cognitive processes to depressive symptoms were significant ($b = .87, p < .01$). Both the total direct ($b = .39$, 95% Bootstrapped CI [.06, .66]) and total indirect ($b = .24$, 95% Bootstrapped CI [.01, .59]) effects were significant ($p < .01$). The size of the direct effect was moderate and the size of the indirect effect was relatively small. The specific indirect effect of alcohol problems on depression, accounting for 61.1% of the variance and the specific direct effect was non-significant ($b = .15, p = .22$). Therefore, the indirect effect is accounting for more than half of the variance in the overall effect for women.

8.2.3.2 Men

The structural model for Time 1 data with men ($n = 56$) demonstrated poor fit; $\chi^2(17) = 28.18, p = .04$, RMSEA = .12, 95% CI (.02, .18), $p = .10$, CFI = .94, TLI = .90, SRMR = .08. In this model, the path from alcohol to depressive symptoms was also not significant, and the standardized regression coefficient was much smaller than it was in the women's model ($b = .05, p = .86$). The path from alcohol problems to distorted

cognitive processes was also non-significant ($b = .18, p = .37$). The only significant path in this model was from distorted cognitive processes to depressive symptoms ($b = .61, p = .02$). It is important to note the significant sample size difference between these two models, which may have significantly altered the parameter estimates of the men's model. No direct or indirect effects were present in this model.

8.3 Longitudinal Analyses

The number of parameter estimates required to conduct longitudinal analyses with the SEM model proposed above was, unfortunately, not possible due to the significant drop-out rate of participants in Time 2. Therefore, a simplified path model was tested that was similar to that of the Community Study and for the same reasons (sample sizes needed for complex models are, at times, prohibitive) to assess how these variables relate to each other over time. A review of the correlation table (*Table 13* in Appendix H) demonstrates that the AUDIT does not correlate well with other measures of distorted cognitive processing, or with measures of depression, compared to the RAPI subscales. This pattern of associations suggests that the frequency and amount of alcohol consumed is not strongly related to either distorted cognitive processing or depressive symptoms. This finding is consistent with the Community Study.

Therefore, the path model included only the RAPI as the associations between this measure and both cognitive measures and measures of depression. Several path models were tested using different indicators, which is consistent with the Community Study. First, path models were created using the strongest indicators for the latent construct alcohol problems (i.e., the social/occupational consequences subscale of the RAPI) and

depressive symptoms (i.e. the cognitive subscale of the BDI-II). The model was tested separately with dysfunctional attitudes and negative information processing bias.

8.3.1 General Longitudinal Model

To begin, a longitudinal model was designed to simply test whether alcohol problems predicted distorted cognitive processes over time, and whether distorted cognitive processes predicted depressive symptoms over time, after controlling for baseline levels of these variables. The model was first tested with dysfunctional attitudes and then with negatively-biased information processing as the distorted cognitive process. Paths from Time 1 alcohol problems to dysfunctional attitudes, from dysfunctional attitudes to depressive symptoms, and from alcohol problems to depressive symptoms were added to the model. This model does not allow for any mediational analyses, but offers an appreciation of how these variables are related over time.

The hypothesized model of longitudinal paths with dysfunctional attitudes ($n = 170$) fit the data very well, $\chi^2(3) = 3.42$, $p = .33$, RMSEA = .03, 95% CI (.00, .14), CFI = .99, TLI = .99, SRMR = .02. The paths from alcohol problems to depressive symptoms was not significant ($b = -.04$, $p = .62$), and neither was the path from alcohol problems to dysfunctional attitudes ($b = .05$, $p = .34$). The path from dysfunctional attitudes to depressive symptoms was significant ($b = .18$, $p = .01$). The autoregressive paths were also all significant. This finding suggests alcohol problems do not predict dysfunctional attitudes, negatively biased information processing, or depressive symptoms over three months.

The hypothesized model using negatively-biased information processing did not fit the data as well as the one with dysfunctional attitudes, ($n = 170$), $\chi^2(3) = 36.46$, $p < .01$,

RMSEA = .26, 95% CI (.19, .33), CFI = .91, TLI = .62, SRMR = .07. The path from alcohol problems to depressive symptoms was, again, non-significant ($b = .02, p = .69$), as was the path from alcohol problems to negatively-biased information processing ($b = -.02, p = .34$). The path from negatively-biased information processing to depressive symptoms was significant ($b = .13, p = .05$). The autoregressive paths were also all significant. Of note, the above models were tested with the total scores of the RAPI and the total score of the BDI-II. The same significant and non-significant paths emerged. Therefore, alcohol problems did not predict dysfunctional attitudes or depressive symptoms over shorter time points. Both dysfunctional attitudes and negatively biased information processing significantly predicted cognitive depressive symptoms.

8.3.2 Mediation Longitudinal Model

Although the paths from alcohol problems to both depressive symptoms and dysfunctional attitudes/negatively-biased information processing were not significant, mediational paths were still tested. The longitudinal structural equation mediation model can be tested using two pathways. The first pathway tests a path from Time 1 alcohol problems to Time 2 depressive symptoms through Time 1 distorted cognitive processes. Path two tests a pathway from Time 1 alcohol problems to Time 2 depressive symptoms through Time 2 distorted cognitive processes. The first path has a larger sample size, and a higher chance of detecting small effects. Therefore, the first path was used throughout (the dotted path in *Figure 14*).

8.3.2.1 Path from the Social and Occupational Consequences of Alcohol to the Cognitive Symptoms of Depression, Through Dysfunctional Attitudes

The hypothesized model from alcohol problems (the social and occupational consequences scale of the RAPI) to cognitive depressive symptoms (the cognitive subscale of the BDI-II) through dysfunctional attitudes did not fit the data well, $\chi^2(5) = 59.26, p < .01$, RMSEA = .21, 95% CI (.16, .25), CFI = .87, TLI = .65, SRMR = .13; however, many of the hypothesized paths were significant (*Figure 17*). The path from Time 1 alcohol problems to Time 1 dysfunctional attitudes ($b = .21, p < .01$) and from Time 1 dysfunctional attitudes to Time 2 cognitive depressive symptoms ($b = .21, p = .01$) were both positive and significant. The direct path from alcohol problems to cognitive depressive symptoms, however, was non-significant ($b = -.05, p = .36$).

Traditionally, indirect effects are not tested when there is no direct path; in this case, from alcohol problems to depressive symptoms (Baron & Kenny, 1986). However, some authors (e.g., Judd & Kenny, 1981; MacKinnon, Krull, & Lockwood, 2000; Preacher & Hayes, 2008, 2008; Shrout & Bolger, 2002) have argued that a significant total effect of one variable on another is not necessary for mediation to occur, as long as the indirect effect is significant. A review of the indirect paths indicates a significant total indirect effect of dysfunctional attitudes on the relationship between alcohol problems and cognitive depressive symptoms ($b = .04, p = .02$, Bootstrapped 95% CI [.02, .09]) and a non-significant total direct effect ($b = -.01, p = .40$, Bootstrapped 95% CI [-.15, .15]). Therefore, there is no evidence that alcohol problems significantly predict cognitive depressive variables over this short time period. It is possible that dysfunctional attitudes explain the majority of the variance in this relationship, precluding a direct path from

alcohol problems to depressive symptoms. Of note, the same model was tested with the total scores of the RAPI and the total score of the BDI-II. The same significant and non-significant paths emerged and the same significant indirect effect emerged.

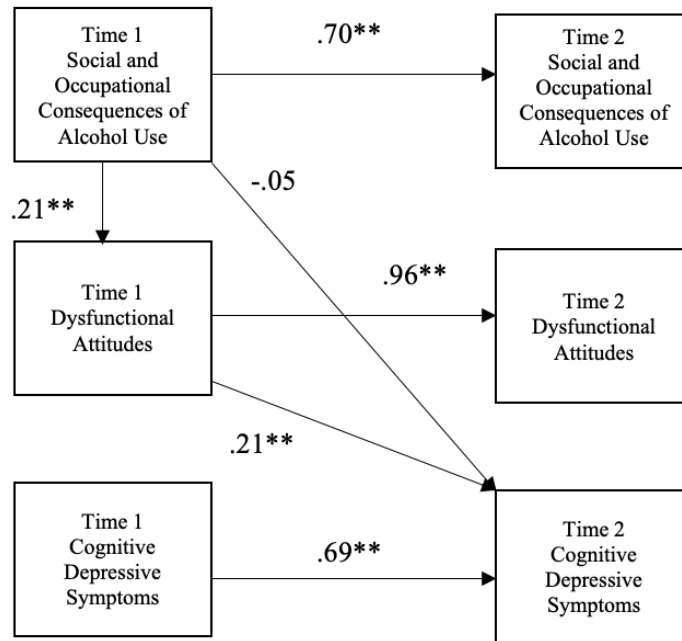

Figure 17. Student sample, from the social and occupational consequences of alcohol use to the cognitive symptoms of depression, through dysfunctional attitudes.

8.3.2.2 Moderated Mediation Analyses, Dysfunctional Attitudes

The same path was tested separately for men and women to determine whether sex moderates the relationship with alcohol problems, dysfunctional attitudes, and cognitive symptoms of depression (*Figure 18*). The model from the alcohol problems to the cognitive symptoms of depression through dysfunctional attitudes demonstrated different patterns for men and women.

Among men ($n = 41$), the fit of the hypothesized model was generally poor, $\chi^2(5) = 10.44$, $p = .06$, RMSEA = .16, 95% CI (.00, .30), CFI = .92, TLI = .78, SRMR = .16.

However, many hypothesized paths were significant. The path from Time 1 alcohol

problems to Time 1 dysfunctional attitudes was significant ($b = .23, p = .02$), and so was the path between Time 1 dysfunctional attitudes and Time 2 cognitive depressive symptoms ($b = .49, p < .01$). No significant indirect effects were present in this model.

The fit of the hypothesized model with women ($n = 136$) was poorer compared to the men's model, $\chi^2(5) = 52.99, p < .01$, RMSEA = .27, 95% CI (.20, .33), CFI = .79, TLI = .42, SRMR = .16. The path from Time 1 alcohol problems to Time 1 dysfunctional attitudes ($b = .16, p = .09$) and from the Social and Occupational Consequences of Alcohol to Cognitive depressive symptoms were non-significant. The path from Time 1 dysfunctional attitudes and Time 2 cognitive depressive symptoms ($b = .18, p = .03$) was significant, and half the size of the men's effect. No significant indirect effects were present in this model. Therefore, there is more evidence that alcohol problems are associated with dysfunctional attitudes among men and evidence that dysfunctional attitudes most strongly predict depressive symptoms among men.

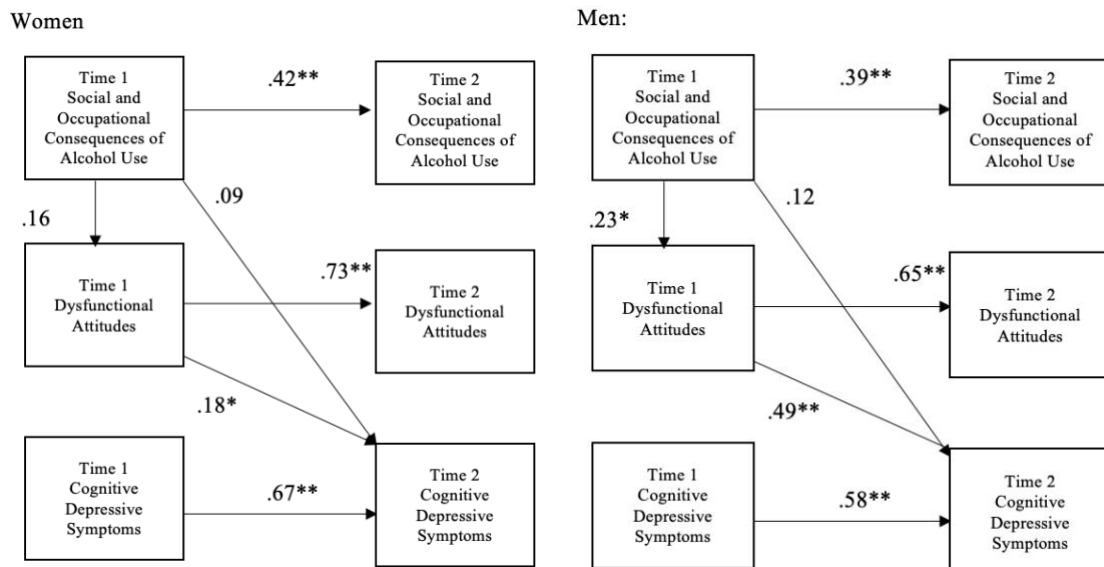

Figure 18. Moderated mediation analyses, alcohol problems to depression through dysfunctional attitudes

8.3.2.3 Path from the RAPI, Social and Occupational Consequences Subscales to BDI, Cognitive Subscale, Through Negatively-biased Information Processing

The hypothesized model from alcohol problems (the social and occupational consequences scale of the RAPI) to cognitive depressive symptoms (the cognitive subscale of the BDI-II) through negatively-biased information processing (SRET) also did not fit the data well; $\chi^2(5) = 102.14$, $p < .01$, RMSEA = .28, 95% CI (.27, .28), CFI = .76, TLI = .35, SRMR = .17. In this model (*Figure 19*), the path from Time 1 alcohol problems to Time 1 negatively-biased information processing was not significant ($b = .04$, $p = .51$), however the path from Time 1 negatively-biased information processing to Time 2 cognitive depressive symptoms ($b = .15$, $p = .05$) was significant.

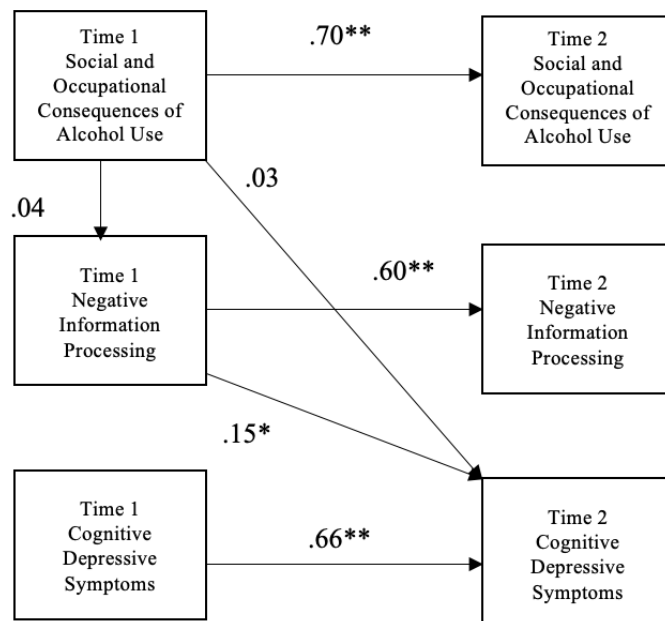

Figure 19. Student sample, from the social and occupational consequences of alcohol use to the cognitive symptoms of depression, through negatively-biased information processing.

The direct path from alcohol problems to cognitive depressive symptoms, again, was non-significant ($b = .03$, $p = .69$). A review of the indirect paths did not reveal any

significant direct or indirect effects. The same model was tested with the total scores of the RAPI and the total score of the BDI-II. No significant paths emerged in that model, suggesting that the significant path from Time 1 negatively-biased information processing to cognitive depressive symptoms is specific to the cognitive symptoms, rather than the somatic symptoms, of depression.

8.3.2.4 Moderated Mediation Analyses with Negatively-biased Information Processing

The same path was tested separately for men and women (*Figure 20*) to determine whether sex moderates the relationship with alcohol problems, negatively-biased information processing, and cognitive symptoms of depression. The model from alcohol problems to the cognitive symptoms of depression through negatively-biased information processing demonstrated similar patterns for men and women.

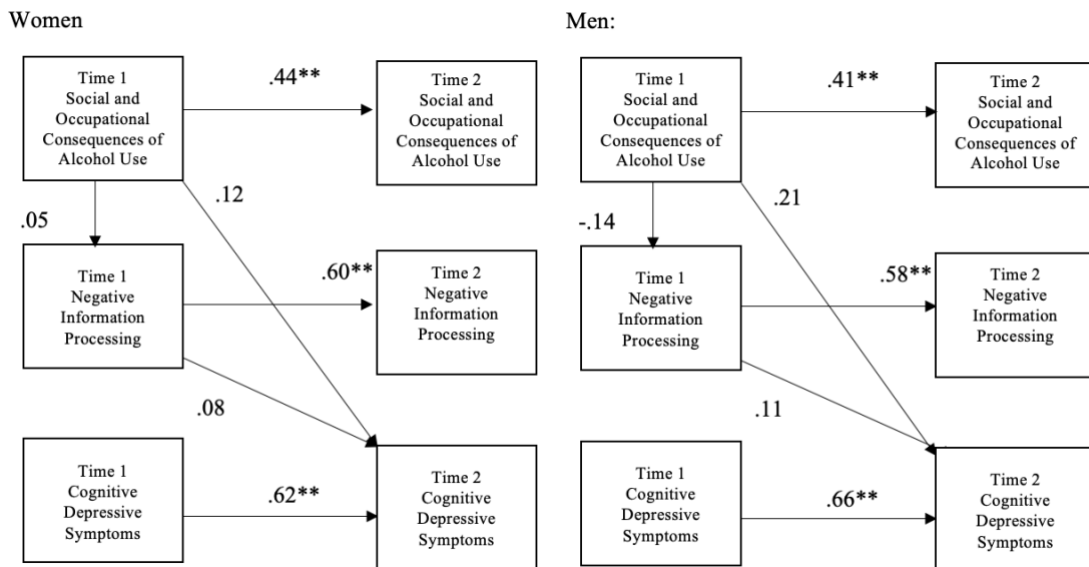

Figure 20. Moderated mediation analyses, alcohol problems to depression through negatively-biased information processing.

Among men ($n = 43$), the fit of the hypothesized model was generally poor, $\chi^2(5) = 21.14, p < .01$, RMSEA = .27, 95% CI (.16, .34), CFI = .72, TLI = .21, SRMR = .15. The same was true for women, $\chi^2(5) = 80.13, p < .01$, RMSEA = .33, 95% CI (.27, .39), CFI = .66, TLI = .06, SRMR = .20. In both models, the paths from alcohol problems to negatively-biased information processing, from alcohol problems to depressive symptoms, and from alcohol problems to depressive symptoms were not significant.

8.4 Alternative Longitudinal Models: From Depression to Alcohol Problems

An alternative model from cognitive depressive symptoms to alcohol problems was tested to determine whether there is evidence in this sample for the Self-Medication Hypothesis, whereby depressive symptoms predict drinking problems. To assess this possibility, the same models as tested above were tested with paths going in the other direction.

8.4.1 General Longitudinal Model

To begin, a longitudinal model was designed to simply test whether depressive symptoms predicted distorted cognitive processes over time, and whether distorted cognitive processes predicted alcohol problems over time, after controlling for baseline levels of these variables. The model was first tested with dysfunctional attitudes and then with negatively-biased information processing. Paths from Time 1 depressive symptoms to dysfunctional attitudes, from dysfunctional attitudes to alcohol problems, and from depressive symptoms to alcohol problems were added to the model. This model does not allow for any mediational analyses, but offers an appreciation of how these variables are related over time. The hypothesized model of longitudinal paths with depressive symptom, dysfunctional attitudes, and alcohol problems ($n = 170$) fit the data reasonably

well, $\chi^2(3) = 9.28$, $p = .33$, RMSEA = .11, 95% CI (.03, .20), CFI = .98, TLI = .93, SRMR = .04, although this same model in the other direction fit the data better.

The paths from depressive symptoms to alcohol problems ($b = .07$, $p = .29$), and from dysfunctional attitudes to alcohol problems ($b = -.09$, $p = .13$) were not significant. The path from depressive symptoms to dysfunctional attitudes was significant ($b = .14$, $p = .04$), yet the effect was smaller than it was in the opposite direction. The autoregressive paths were also all significant. There is no evidence that depressive symptoms can predict alcohol problems any better than alcohol problems can predict dysfunctional attitudes or depression over shorter time points. There is evidence, however, that depressive symptoms predict dysfunctional attitudes over time. These findings are consistent with the Community Study.

The hypothesized model of longitudinal paths with depressive symptoms, negatively-biased information processing, and alcohol problems ($n = 170$) fit the data reasonably well, $\chi^2(3) = 9.46$, $p = .08$, RMSEA = .11, 95% CI (.04, .20), CFI = .98, TLI = .93, SRMR = .04. Unlike the model in the opposite direction, many paths were significant in this model. The paths from depressive symptoms to negatively-biased information processing was significant ($b = .35$, $p < .01$), and so was the path from negatively-biased information processing to alcohol problems ($b = .15$, $p = .02$). The direct path from depressive symptoms to alcohol problems was not significant ($b = .09$, $p = .15$).

Thus, there is evidence that depressive symptoms predict changes in negatively-biased information processing, and that changes in negatively-biased information processing can predict changes in alcohol problems, over time, after controlling for

baseline levels of these variables. The same significant and non-significant paths emerged when the models were tested with the total scores of the RAPI and the total score of the BDI-II.

8.4.2 Mediation Longitudinal Alternative Model

The alternative model with negatively-biased information processing is particularly interesting, as this model indicates that cognitive depressive symptoms can predict negatively-biased information processing, and that negatively-biased information processing can predict alcohol problems in the student sample. While the path from dysfunctional attitudes to alcohol problems was not significant, mediation models were still tested with both distorted cognitive processes. Path from the RAPI, Social and Occupational Consequences Subscales to BDI, Cognitive Subscale, Through DAS

The hypothesized model from cognitive depressive symptoms to alcohol problems through dysfunctional attitudes fit the data better than it did in the model in the other direction, $\chi^2(5) = 16.99, p < .01$, RMSEA = .09, 95% CI (.05, .15), CFI = .97, TLI = .92, SRMR = .07, and some of the hypothesized paths were significant (*Figure 21*). The path from Time 1 depressive symptoms to Time 1 dysfunctional attitudes ($b = .47, p < .01$) was significant and this effect was stronger than it was in the opposite direction (again, consistent with the Community Study), as were all autoregressive paths. The path from dysfunctional attitudes to alcohol problems was non-significant ($b = -.09, p = .20$) and neither was the direct path from depressive symptoms to alcohol problems ($b = .05, p = .40$). There were no significant indirect effects. The same model was tested with the total scores of the RAPI and the total score of the BDI-II. The same significant and non-significant paths emerged and the same significant indirect effect emerged.

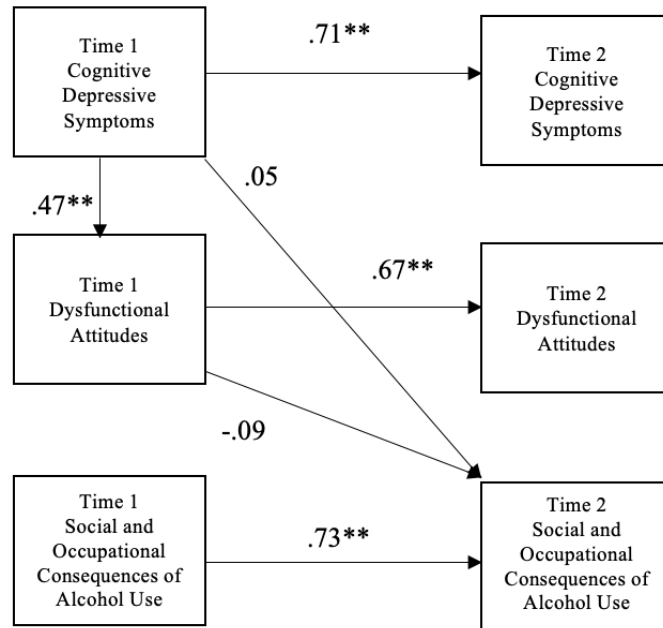

Figure 21. Student sample, from the cognitive symptoms of depression to the social and occupational consequences of alcohol use, through dysfunctional attitudes.

8.4.2.1 Moderated Mediation Analyses, Dysfunctional Attitudes

The same path was tested separately for men and women (*Figure 22*) to determine whether sex moderates the associations between depressive symptoms, dysfunctional attitudes, and alcohol problems. The fit of the hypothesized model with women ($n = 136$) was excellent, $\chi^2(5) = 9.46$, $p = .09$, RMSEA = .08, 95% CI (.00, .16), CFI = .98, TLI = .95, SRMR = .06, especially compared to the men's model. The path from Time 1 depressive symptoms to Time 1 dysfunctional attitudes was significant ($b = .57$, $p < .01$), and the effect was stronger than it was in the opposite direction, suggesting that depressive symptoms are a far stronger predictor of dysfunctional attitudes for women than dysfunctional attitudes are of depressive symptoms (consistent with the Community Study). The path from Time 1 depressive symptoms to Time 2 alcohol problems was non-significant ($b = -.01$, $p = .94$) and neither was the path from Time 1 dysfunctional

attitudes to Time 2 alcohol problems ($b = .00, p = .97$). No significant indirect effect was present in this model.

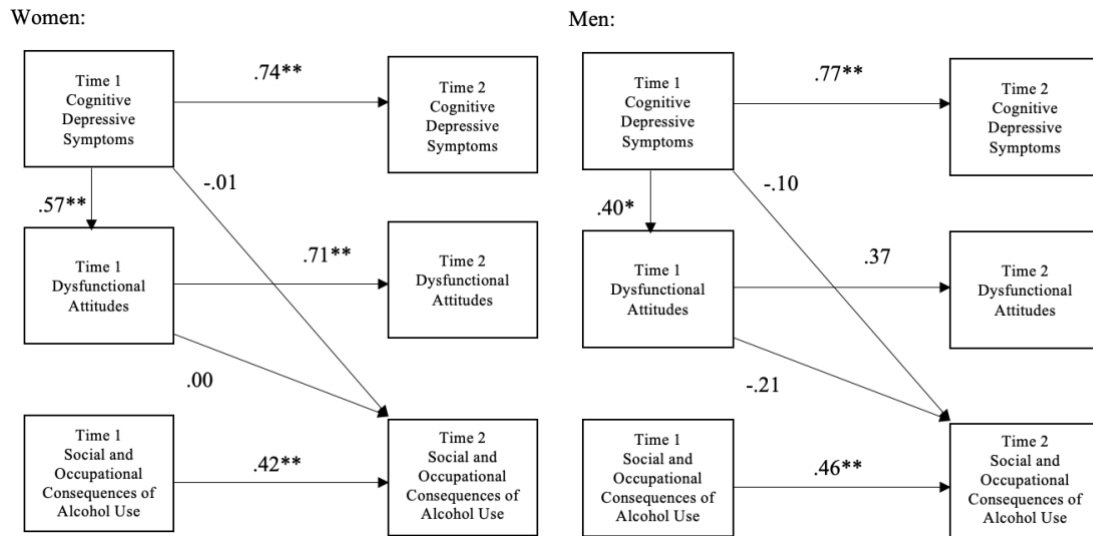

Figure 22. Moderated mediation analyses, depressive symptoms to alcohol problems through dysfunctional attitudes.

Among men ($n = 43$), the fit of the hypothesized model was generally poor, $\chi^2(5) = 13.84, p < .01$, RMSEA = .20, 95% CI (.08, .33), CFI = .87, TLI = .64, SRMR = .17. The path from Time 1 depressive symptoms to Time 1 dysfunctional attitudes was significant ($b = .40, p = .02$) and the effect was similar to this path in the opposite direction, suggesting that depressive symptoms both lead to and are predicted by dysfunctional attitudes among men. The path from Time 1 depressive symptoms to Time 2 alcohol problems was not significant ($b = -.10, p = .40$). Neither was the path from Time 1 dysfunctional attitudes to Time 2 alcohol problems ($b = -.21, p = .40$). No significant indirect effect was present in this model. For the first time, the path from Time 1 dysfunctional attitudes to Time 2 dysfunctional attitudes was not significant ($b = .37, p = .19$).

8.4.2.2 Path from BDI (Cognitive Subscale) to RAPI (Social and Occupational Consequences Subscale) Through Negatively-biased Information Processing

The hypothesized model from depressive symptoms to alcohol problems through negatively-biased information processing (*Figure 23*) fit the data better than the model in the other direction; $\chi^2(5) = 37.34, p < .01$, RMSEA = .16, 95% CI (.11, .21), CFI = .92, TLI = .78, SRMR = .08. The path from Time 1 depressive symptoms to Time 1 negatively-biased information processing was significant ($b = .47, p = .05$) as was the path from Time 1 negatively-biased information processing to Time 2 alcohol problems ($b = .16, p = .02$). The direct path from depressive symptoms to alcohol problems, however, again was non-significant ($b = -.05, p = .50$).

A review of the indirect paths revealed a significant total indirect path between depressive symptoms and alcohol problems ($b = .07, p = .02$, Bootstrapped 95% CI [.01, .15]) and no significant total direct effect ($b = .03, p = .66$, Bootstrapped 95% CI [-.14, .17]). The indirect effect here was slightly larger than the one in the opposite model. Therefore, there is no evidence that alcohol problems significantly predicted cognitive depressive variables over this short time period, however there is some evidence that negatively-biased information processing is influencing these variables over time.

The same model was tested with the total scores of the RAPI and the total score of the BDI-II. The only significant path that emerged was the path from depressive symptoms to negatively-biased information processing. The path from negatively-biased information processing to alcohol problems was not significant in the model using total scores, perhaps suggesting that this effect is specific to the social and occupational consequences of alcohol use.

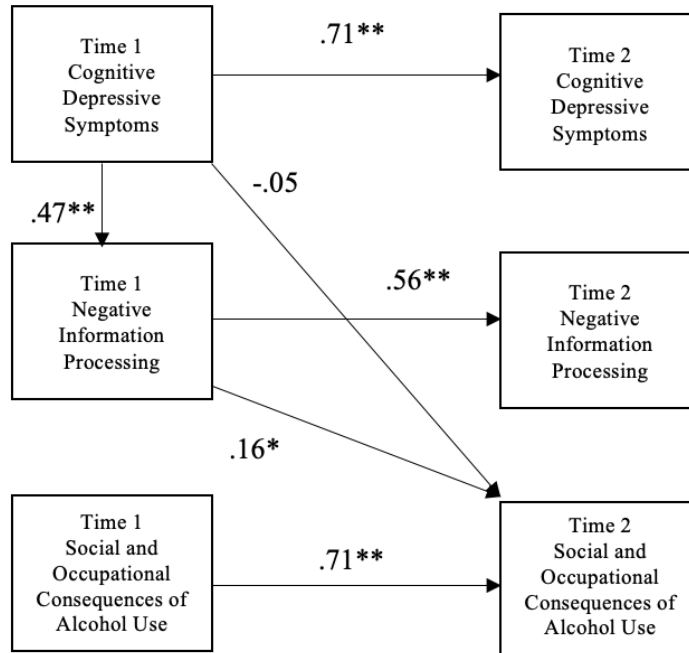

Figure 23. Student sample, from the cognitive symptoms of depression to the social and occupational consequences of alcohol use, through negatively-biased information processing.

8.4.2.3 Moderated Mediation Analyses with Negatively-biased Information Processing

The same paths were tested separately for men and women (*Figure 24*) to determine whether sex moderates the associations between depressive symptoms, negatively-biased information processing, and alcohol problems. The model from depressive symptoms to alcohol problems through negatively-biased information processing demonstrated the same pattern for men and women. Among men ($n = 43$), the fit of the hypothesized model was generally poor, $\chi^2(5) = 13.32, p = .02, RMSEA = .20, 95\% CI (.07, .33), CFI = .86, TLI = .60, SRMR = .17$. The same was true for women, $n = 136, \chi^2(5) = 35.29, p < .01, RMSEA = .21, 95\% CI (.15, .28), CFI = .87, TLI = .62, SRMR = .10$. In both models, the paths from depressive symptoms to negatively-biased

information processing were significant (Women: $b = .53, p < .01$; Men: $b = .35, p = .02$). The paths from depressive symptoms to alcohol problems were non-significant and the paths from negatively-biased information processing to alcohol problems were non-significant. No indirect effects emerged. Sample sizes in each case were small.

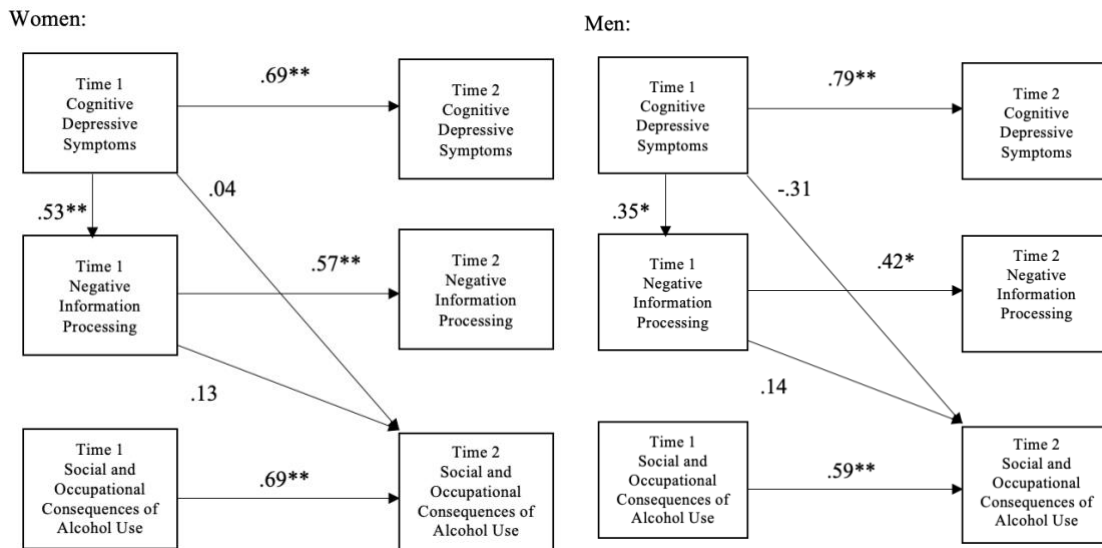

Figure 24. Moderated mediation analyses, depression to alcohol problems through negatively-biased information processing.

8.5 Third Variable Hypothesis.

In the simple longitudinal models, there is evidence that negatively-biased information processing predicted both depressive symptoms and alcohol problems. A third variable hypothesis is tested in Chapter 10. There was no evidence from any of the models above that ruminative thinking mediated the effect of alcohol problems on depressive symptoms, therefore analyses using this measure are not outlined in detail.

Chapter 9

9 Student Study Part 2: Drinking Motives

The reasons for why people drink have been widely found to influence the amount of alcohol consumed, and the problems caused by alcohol (Colder, 2001; Cooper, 1994; Foster et al., 2014; Kuntsche et al., 2006). Existing longitudinal studies have not found clear evidence that coping motives predict changes in alcohol consumption and have found more evidence that enhancement motives predict changes in drinking patterns among college students (Armeli et al., 2010; Read, Wood, Kahler, Maddock, & Palfai, 2003). However, when alcohol problems are assessed (e.g., consequences of alcohol use), there is more evidence that drinking to cope predicts alcohol problems over time (Read et al., 2003).

A review of the correlation tables (*Table 13* in Appendix H) does not support that enhancement motives are strongly linked to alcohol use ($r = .44$ falls in the modest range), but social motives, conformity motives, and coping motives are more strongly linked ($r = .65$, $r = .66$, and $r = .50$, respectively, falling in the strong range) cross-sectionally. Conformity ($r = .66$) was relatively the most strongly associated with total AUDIT scores, and was more strongly associated with total AUDIT scores than coping motives ($r = .50$, $z = 2.76$, $p = .01$) and enhancement motives ($r = .44$, $z = 3.63$, $p < .01$), but not statistically differently associated with social motives ($r = .65$). Social motives ($r = .65$) were more strongly associated with total AUDIT scores than coping motives ($r = .50$, $z = 2.56$, $p = .01$) and enhancement motives ($r = .44$, $z = 3.43$, $p < .01$). Coping motives ($r = .50$) were not significantly differently associated with total AUDIT scores

compared to enhancement motives. Therefore, total AUDIT scores were most strongly associated with conformity and social motives than with coping or enhancement motives cross-sectionally. It is unclear how these variables influence each other over time. Since the literature provides the strongest theoretical argument for a relationship between coping motives and drinking problems over time, and because the CFA in this dissertation found this subscale to be the most psychometrically sound (see Appendix C) it may be fruitful to assess how coping motivations, specifically, predict alcohol problems over time. To generally assess how coping motives are related to alcohol problems and depressive symptoms, an initial CFA was conducted (see Appendix I). The data fit the model well and the variables were significantly associated with each other.

9.1.1 SEM with Drinking Motives, Alcohol Problems, Distorted Cognitive Processes, Depression

The hypothesized model from coping motives to alcohol problems, and from alcohol problems to depression through dysfunctional attitudes, fit the data well, $n = 257$, $\chi^2(12) = 36.90$ $p < .01$, RMSEA = .09, 95% CI (.06, .24), $p = .02$, CFI = .97, TLI = .94, SRMR = .04. All of the paths here were significant at $p = .05$ (Figure 25). The total indirect effect of cognitive variables was significant ($b = .10$, $p < .01$, Bootstrapped 95% CI [.04, .17]) and so was the total direct effect from alcohol problems to depressive symptoms ($b = .29$, $p < .01$, Bootstrapped 95% CI [.12, .48]). This mediation effect accounted for 26% of the variance in the direct relationship.

9.1.2 Longitudinal SEM with Coping Motives, Alcohol Problems, Dysfunctional Attitudes, and Depressive Symptoms

With this well-fitting, hypothesized SEM, longitudinal analyses were conducted from coping motivations to depressive symptoms. The longitudinal model hypothesized that drinking to cope predicts alcohol problems, alcohol problems predict dysfunctional attitudes, and dysfunctional attitudes predict depressive symptoms (*Figure 26*). The hypothesized model, $n = 170$, $\chi^2(9) = 20.62$, $p < .01$, RMSEA = .09, 95% CI (.04, .14), $p = .10$, CFI = .98, TLI = .95, SRMR = .05, fit the data well. The only path that was not significant was from alcohol problems to dysfunctional attitudes ($b = .06$, $p = .25$). When the path from Time 1 alcohol problems to Time 2 dysfunctional attitudes was reversed, so that Time 1 dysfunctional attitudes were hypothesized to predict Time 2 problems, $n = 257$, $\chi^2(12) = 85.20$, $p < .01$, RMSEA = .15, 95% CI (.12, .19), $p < .01$, CFI = .88, TLI = .75, SRMR = .12, most paths were significant.

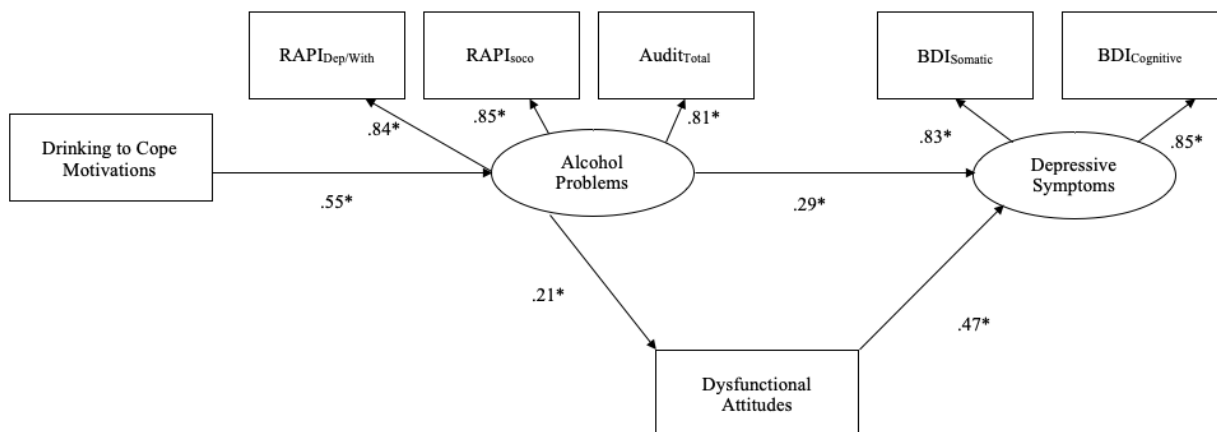

Figure 25. SEM with drinking to cope, alcohol problems, dysfunctional attitudes, and depressive symptoms (Time 1).

9.1.3 Longitudinal SEM with Coping Motives, Alcohol Problems, Negatively-biased Information Processing, and Depressive Symptoms

Given the evidence from the above models that negatively-biased information processing predicts alcohol problems over time, the model was re-run with negatively-biased information processing instead of dysfunctional attitudes, $n = 170$, $\chi^2(9) = 44.49$, $p < .01$, RMSEA = .15, 95% CI (.12, .20), $p < .01$, CFI = .93, TLI = .84, SRMR = .07. The hypothesized model did not support the data well. The path from alcohol problems to negatively-biased information processing was not significant ($b = -.05$, $p = .37$) and neither was the path from negative information processing bias to depression ($b = .09$, $p = .17$). The path from coping motives to alcohol problems remained significant in this model ($b = .13$, $p < .01$). Sample sizes were too small to meaningfully interpret moderated mediation effects, and, therefore, these analyses were not conducted.

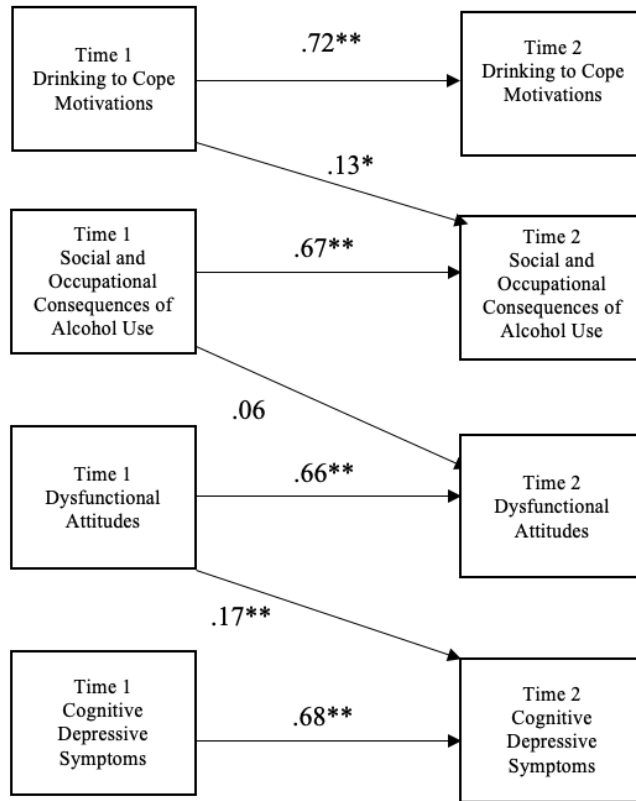

Figure 26. Longitudinal model from drinking to cope to depressive symptoms.

Chapter 10

10 One Final Model

Evaluating the relationship between alcohol, distorted cognitive processes, drinking to cope motivations, and alcohol problems has revealed an interesting pattern of relationships over time. The above analyses have indicated that negatively-biased information processing predicts both depressive symptoms and alcohol problems over time. Coping motives also predict alcohol problems over time. Dysfunctional attitudes predict depressive symptoms, and depressive symptoms predict dysfunctional attitudes. When a model was created that allowed all of these paths to exist, the path from Time 1 depressive symptoms to Time 2 dysfunctional attitudes was non-significant. Therefore, there is more evidence that dysfunctional attitudes predict depressive symptoms over this short time frame.

The model whereby coping motives predict alcohol problems, negatively-biased information processing predicts both depressive symptoms and alcohol problems, and dysfunctional attitudes predict depressive symptoms was tested (*Figure 27*). The hypothesized model, $n = 170$, $\chi^2(16) = 56.69$, $p < .01$, RMSEA = .12, 95% CI (.09, .16), $p < .01$, CFI = .93, TLI = .86, SRMR = .07, while not fitting the data exceptionally well, revealed that all predicted paths were significant. Therefore, while no direct association exist over two-to-three-month periods for college students, a clear third variable hypothesis model is revealed, whereby changes in depressive symptoms at Time 2 can be predicted by negatively-biased information processing and dysfunctional attitudes at Time 1 and changes in alcohol problems can be predicted by drinking to cope motivations and negatively-biased information processing at Time 1.

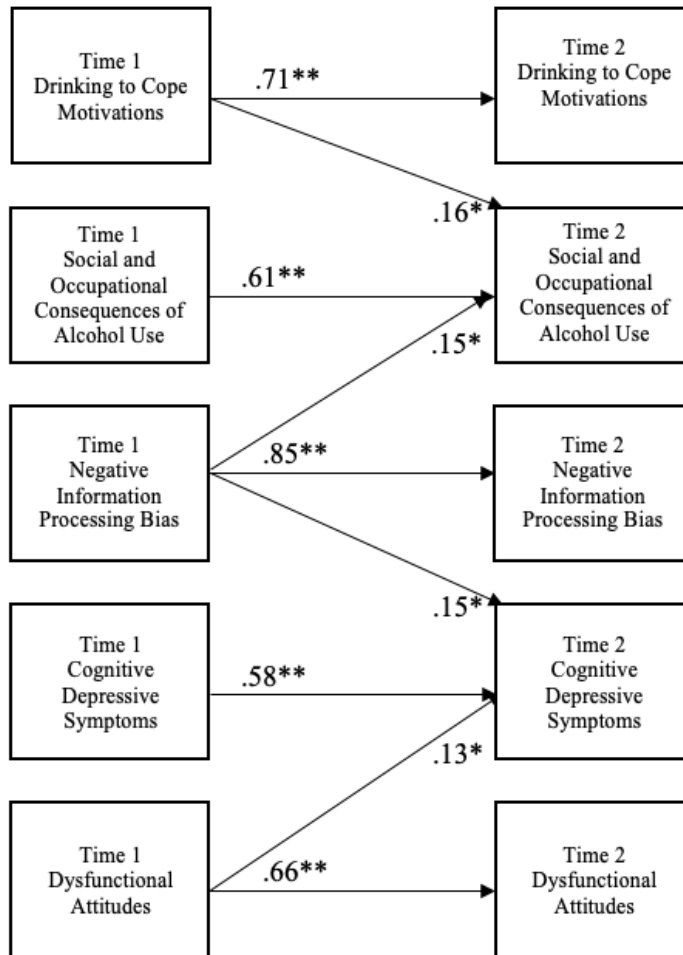

Figure 27. The third variable hypothesis supported, distorted cognitive processes and drinking motivations predict alcohol problems and depression over time.

Chapter 11

11 Conclusions for the Student Study

Cross-sectional hypotheses were that; (1) individuals with higher levels of alcohol problems would experience higher levels of depressive symptoms at each time point; (2) distorted cognitive processes (e.g., dysfunctional attitudes, negatively biased information processing, rumination) would mediate the relationship between alcohol problems and depressive symptoms at each time point; and (3) drinking motives, specifically drinking to “cope”, would predict alcohol problems.

Consistent with the Community Study, cross-sectional analyses at Time 1 revealed a positive relationship between alcohol problems and depressive symptoms. **Therefore, there is support for the hypothesis that alcohol problems and depressive symptoms are positively related.** Also consistent with the Community Study, cross-sectional analyses of Time 1 data revealed a significant mediation effect of distorted cognitive processes in the relationship between alcohol problems and depressive symptoms. This indirect effect accounted for 45.9% of the variance. The paths from alcohol problems to distorted cognitive processes, and from distorted cognitive processes to depressive symptoms were significant. The mediated effect, again, was stronger in women compared to men. **Therefore, there is support for the hypothesis that distorted cognitive processes mediate the relationship between alcohol problems and depressive symptoms, and that this effect is stronger for women compared to men, cross-sectionally.**

Longitudinal hypotheses posited that; (1) individuals with higher baseline drinking problems would experience higher levels of distorted cognitive processes and depressive

symptoms at Time 2 (after controlling for baseline levels of distorted cognitive processes and depressive symptoms); (2) individuals with higher baseline distorted cognitive processes will experience higher levels of depressive symptomatology at Time 2; (3) distorted cognitive processes will mediate the relationship between alcohol problems and depressive symptoms; and (4) drinking to cope will predict alcohol problems over time;

The simple longitudinal model did not support the first hypothesis that higher baseline drinking problems predict higher distorted cognitive processes. Rather, the alternative model provided evidence that negative information processing bias, but not dysfunctional attitudes, predicted higher baseline drinking problems. Over the shorter time frame of the Student Study, **no significant direct paths from alcohol problems to depressive symptoms emerged for any of the models**, nor did any direct paths from depressive symptoms to alcohol problems emerge in the alternative models tested. Importantly, and consistent with the Community Study, these models also, again, revealed that the social and occupational consequences of alcohol use are more strongly associated with both cognitive variables and depressive symptoms, compared to the amount or frequency of alcohol use.

The simple longitudinal model and the mediation models provided evidence that negative information processing bias and dysfunctional attitudes predicted depressive symptoms. Moderated mediation analyses revealed that the path from Time 1 dysfunctional attitudes to Time 1 depressive symptoms is more than twice as strong for men compared to women, however the path from depressive symptoms to dysfunctional attitudes is stronger for women compared to men. Moderated mediation analyses did not

find a significant path from negative information processing bias to depressive symptoms for either men or women.

The longitudinal models also revealed a significant indirect effect of dysfunctional attitudes from alcohol problems to depressive symptoms, however, again, no direct effect was present. When alternative models were tested with negative information processing bias, a significant indirect effect of negative information processing bias was found. This effect surfaced in the absence of a direct effect. This indirect effect may simply indicate that negative information processing is related to both depressive symptoms and alcohol problems, but that alcohol problems and depressive symptoms are not closely related in this time frame.

Indeed, when a third variable hypothesis was tested whereby negative information processing bias predicted both depressive symptoms and alcohol problems, and dysfunctional attitudes predicted depressive symptoms, all paths were significant. The last hypothesis posited that drinking to cope with negative emotions would predict alcohol problems over time. Coping motives predicted social and occupational consequences of drinking in both cross-sectional and longitudinal models. This effect was stronger for men compared to women.

Chapter 12

12 General Discussion

Alcohol has long been used as a means to “self-medicate” stress, negative mood, and unpleasant situations. In *Lord of the Rings*, J.R.R. Tolkien writes “Ho! Ho! Ho! To the bottle I go/To heal my heart and drown my woe” (Tolkien, 1954). In modern society, alcohol continues to be informally marketed as a method of coping with distress or lifting one’s spirits. Countless movies, TV shows, and songs depict grieving, dejected, and heartbroken individuals drinking to manage negative emotional states (Connolly, Casswell, Zhang, & Silva, 1994). Inspired by these informal accounts, as well as by emerging theories of alcohol being used as a means of “tension-reduction” (Conger, 1956; Cooper et al., 1992), Khantzian and his colleagues developed the Self-Medication Hypothesis (Khantzian, 1997; Khantzian, Halliday, & McAuliffe, 1990) - the first formal, comprehensive psychological theory to help conceptualize substance use disorders.

The Self-Medication Hypothesis suggests that substance use disorders evolve out of an attempt to alleviate confusing and painful emotions. This theory posits that the amount and frequency of the substance consumed should be proportional to the individual’s level of distress, and that the substance consumed should be associated with both the individual’s personality characteristics and the unwanted experiences being “self-medicated”. For example, an individual who’s distress presents as attentional difficulties would prefer amphetamines to alcohol, due to amphetamines’ stimulating properties, whereas those for whom distress manifests as anxiety or depression would prefer alcohol to amphetamines, due to alcohol’s anxiolytic and short-term antidepressant properties (Lembke, 2012). The theory that personality factors partly drive substance choice has

been recently empirically supported (McKernan et al., 2015); however, the other components of this theory remain under scrutiny.

To understand how this theory assists in our understanding of AUDs, for example, its assumptions must be elucidated. The two major assumptions behind this theory are that a) the amount of alcohol consumed is directly proportionate to the level of distress an individual is experiencing; and b) the “medicinal” properties of alcohol succeed in alleviating distress (or numbing the experience of distress) thus perpetuating the cycle of alcohol use. After 30 years of research empirically testing this theory, there are surprisingly little data to support these conjectures (Hall & Queener, 2007; Lembke, 2012).

Although there is some evidence that alcohol and other substances temporarily improve mood (Weiss et al., 1992), there is little evidence that depressive symptoms, specifically, decrease following substance use (Lembke, 2012; Tremblay & Pulford, 2009). Rather, there is evidence that drinking larger amounts, often referred to as “binge drinking” leads to consistently lower mood compared to drinking moderately (Townshend & Duka, 2005), especially among individuals who drink problematically (Freed, 1978). There is also little evidence that mood states can predict alcohol consumption (Lembke, 2012; Tremblay & Pulford, 2009).

The studies that have found a relationship between these two variables have generally found it to emerge after several months or multiple years of drinking (Aneshensel & Huba, 1983a; Boden & Fergusson, 2011; Fergusson et al., 2009; Gémes et al., 2019). It may be that the physiological effects of alcohol are influencing biological (e.g., reduced availability of certain mood-regulating neurotransmitters) changes over

time. In general, however, studies which have focused on the relationship between depressive symptoms and the amount of alcohol consumed, the frequency of alcohol consumption, and binge drinking behaviours (as opposed to the difficulties caused by alcohol) in shorter time frames (over months) have not found any relationship between the amount and frequency of alcohol consumed and depressive symptoms at all (e.g., Tremblay & Pulford, 2009). Why is this the case? If alcohol is theoretically promising at medicating emotional states such as depression, and if there is some evidence of cross-sectional relationships between these variables, why do individuals who drink excessively continue to experience depression? Why do the theoretically “tension reducing” effects of alcohol use not last over time – or appear at all?

Over 100 years ago, psychologist George Partridge set out to “gather facts about the intoxication impulse” (Partridge, 1900 p. 318). He keenly noted that “a stage of exhilaration is followed by a stage of depression” (Partridge, 1900, p. 329). Around the same time, the British Medical Journal published an entire section entitled “A Discussion of Alcohol in Relation to Mental Disorders”, where physicians across Britain contributed their scientific observations about this relationship. One contributor, Dr. David Yellowlees, the medical superintendent at the Glasgow Asylum, discussed the various insanities caused by alcohol use; “one type of alcoholic insanity had often struck him – the melancholia occurring about the climacteric period in those who had been addicted to drinking in earlier life, as if the errors of youthful days had at last to be heavily paid for” (Hyslop et al., 1903, p .820).

These findings, along with centuries of literature, anecdote, science, and observation have led to an interesting contradiction; *although individuals may consume*

alcohol as a means of assuaging depressive affect, alcohol is also a cause of that very affect among individuals who drink problematically. Among individuals who do not engage in problematic drinking patterns, alcohol was generally successful in temporarily improving mood (Freed, 1978). Importantly, however, these non-problematic drinkers tended not to drink with the *purpose* of alleviating or distracting from negative mood states. This pattern of findings has naturally led to a fruitful “Chicken or Egg” scientific literature attempting to untangle whether alcohol or depressive affect appeared first among problematic drinkers, what other factors may influence this relationship, and how this knowledge can be applied to treating individuals who suffer from both depression and alcohol-related problems (Boden & Fergusson, 2011; Hartka et al., 1991).

Studies which have attempted to map the trajectory of the relationship between depressive symptoms and alcohol use have used vastly different time frames; from months (Aneshensel & Huba, 1983b) to multiple years (e.g., Brière et al., 2014; Gémes et al., 2019; Hartka et al., 1991; Lee et al., 2018; Schleider et al., 2019), and have operationalized alcohol use and depressive symptoms differently. Some studies have focused on the frequency and amount of alcohol consumed and how it relates to depressive symptoms (Hartka et al., 1991; Tremblay & Pulford, 2009). Others have assessed this relationship in clinical populations where participants have diagnoses of MDD and/or AUD (Boden & Fergusson, 2011; Brière et al., 2014; Grant, Hasin, & Dawson, 1995). Some studies have operationalized depressive symptoms using empirically supported measures of MDD, such as the Beck Depression Inventory or the Composite International Diagnostic Interview (Bellos et al., 2016; Fergusson et al., 2009; Kenneson et al., 2013; Tremblay & Pulford, 2009; J. Wang & Patten, 2002), whereas

others assessed depressive affect using single questions, like “do you often feel depressed?” (Hartka et al., 1991). These different approaches have unsurprisingly led to varying results.

The studies that generally *have* found a positive association between alcohol and depression over time have focused on AUDs, which are characterized by *impairment*. In the DSM-5 (APA, 2013), AUDs are characterized by a problematic pattern of drinking that leads to *clinically significant impairment*, regardless of the amount or frequency consumed. This clinical conceptualization of problematic drinking suggests that, regardless of how much people are consuming, it does not lead to pathology until the drinking patterns cause problems. This is likely a major reason why the impairment aspect of alcohol use needs to be considered in studies assessing how alcohol use is related to other psychopathologies, such as depression, and why studies that focus exclusively on drinking patterns may not offer as much insight into alcohol’s relationship with other disorders.

Among the studies that do assess drinking problems and depressive symptoms, many claim that alcohol and depressive symptoms share a causal connection, rather than being associated due to third variable factors (Aneshensel & Huba, 1983a, 1983b; Boden & Fergusson, 2011; Conner, Piquart, & Gamble, 2009; Fergusson et al., 2009). Importantly, however, these studies ruled out “third-variable” hypotheses because no shared environmental or genetic factors could entirely account for this relationship (Fergusson et al., 2009; Foo et al., 2018; Grant et al., 1995; Hartka et al., 1991; Kendler, Heath, Neale, Kessler, & Eaves, 1993; Kuo et al., 2006; Lyons et al., 2006; Prescott et al.,

2000). Interestingly, no one has proposed that cognitive processes may explain the development or maintenance of both disorders.

This gap is interesting because, although the literatures on alcohol problems and cognitive variables (e.g., Armeli et al., 2010; Caselli et al., 2010; Heinz, Veilleux, & Kassel, 2009) and depression and cognitive variables (e.g., Abela & D'Alessandro, 2002; Austin et al., 2001; Beck, 1963, 2008; C. E. A. Wang et al., 2010) abound, they have rarely been integrated. Few studies have considered the role of cognitive variables in the relationship between alcohol problems and depressive symptoms (e.g., Chabon & Robins, 1986; Ramsey et al., 2002) and these studies appear more focused on the treatment, rather than etiology, of these disorders. The remarkable social, personal, and financial burden that both alcohol problems and depressive symptoms confer (Kessler et al., 2009) necessitates an exploration of this possibility to better assist clinical, institutional, and governmental efforts to both prevent and treat this comorbidity.

The purpose of this dissertation was to assist in this important endeavour by offering a comprehensive, prospective, longitudinal, evaluation of the relationship between alcohol problems, depressive symptoms, and the variables that influence this relationship. Cognitive variables, such as dysfunctional attitudes, ruminative thinking, and negative information processing bias have been long identified as relating to both depressive affect and alcohol-related problems (Conner, 2011), yet have rarely been proposed as mediators or moderators in this relationship. The present study evaluated the relationship between these variables over three-month, six-month, and one-year intervals.

Consistent with other research using both university student (Tremblay et al., 2010; Tremblay & Pulford, 2009) and general community samples (Hartka et al., 1991), the

present studies observed remarkable stability of both depressive symptoms and alcohol problems over time. In the present studies and others, the best predictor of future depressive symptoms were past depressive symptoms and the best predictor of future alcohol problems were past alcohol problems (e.g., Aneshensel & Huba, 1983a; Hartka et al., 1991). Further, there was very little variation in alcohol use frequency and amount. Thus, individuals who drink alcohol generally did not change their drinking habits based on changes in mood or changes in situation. That is, individuals who drink tend to drink across moods, stressful situations, and levels of distress.

With that general finding in mind, both studies in this dissertation did reveal some variation in depressive symptoms and alcohol problems over time. In the Community Study, alcohol problems were generally highest in the winter months and decreased over time, although not significantly. Further, and consistent with previous research on sex differences in depressive symptoms (Nolen-Hoeksema, 1990), women displayed significantly higher levels of depression compared to men. Therefore, there is support for seasonally-related changes in affect and for the well-documented sex differences in affective disorders (Nolen-Hoeksema, 1990).

In the Student Study, depressive symptoms decreased over the three-month time period and there were no sex differences. This finding is also consistent with other studies of depressive symptoms in student samples, where depressive symptoms are highest at the beginning of the semester and slightly, but non-significantly, higher for women compared to men (Tremblay & Pulford, 2009). Therefore, while shared environmental stressors related to the student sample (i.e., students starting their first year

of university) influence mood, depression is generally stable, generally higher in the winter months, and generally higher for women compared to men.

Overall, alcohol problems were higher among men compared to women, and were slightly higher in the winter months and generally quite stable. Again, this is consistent with other longitudinal research on alcohol use and alcohol problems which generally find that men drink more than women, and suffer more alcohol-related problems compared to women (Lee et al., 2018; Nolen-Hoeksema & Hilt, 2006; J. Wang & Patten, 2001). Alcohol use is also well-known to be highly stable over time (Conner et al., 2009). Among students, alcohol consumption was highest at the beginning of the semester and decreased over the three months, again likely as a result of situational influences such as Frosh Week at the beginning of the semester, and fewer organized social engagements during exam time.

Dysfunctional attitudes showed some variability, generally being higher in the warmer months and lower in the colder months. This finding is also consistent with previous research finding instability in dysfunctional attitudes over time, especially for younger samples (Hankin, 2008). Dysfunctional attitudes have a somewhat challenging trajectory to capture, as they are generally found to be stable in terms of individuals being dispositionally more dysfunctional in their thought patterns, but they are also known to vary with stressful life events (C. E. A. Wang et al., 2010), and coincide with changes in depressive symptoms (Halvorsen, Wang, Eisemann, & Waterloo, 2010). Ruminative thinking, which is generally thought to drop from early adolescence to adulthood and then remain relatively stable (Hankin, 2008), was relatively stable in the Student Study.

Consistent with previous research (D. P. Johnson & Whisman, 2013), ruminative thinking was higher among women compared to men, although this effect was small.

Negative information processing bias decreased over time in the Student Study. There is actually very little research on the stability of negative information processing bias, so these findings may present some preliminary evidence that negative information processing bias, often seen as more of a trait-like characteristic (Hammen & Zupan, 1984; Otto, 2007), varies over time. There is some evidence from studies with children of low, but significant, stability in negatively-biased self-referent information processing from ages six to nine (B. L. Goldstein, Hayden, & Klein, 2015) and evidence that negatively-biased information processing remits following depressive episodes (Dobson & Shaw, 1987b), but little research on natural fluctuations in this variable among adults over time. It is likely, in the student sample presented in this dissertation, that negative information processing bias decreased as stress-levels decreased among students, or as they learned to cope with the challenges of university life.

The evidence of some instability in many of the variables above offers an opportunity to assess whether the instability can be partly explained by the hypothesized relationships between them. The overall hypotheses in this dissertation suggested that alcohol problems predicted changes in depressive symptoms (that this relationship was stronger than the relationship in the opposite direction), and the distorted cognitive processes mediated this relationship. This hypothesis was tested both cross-sectionally and longitudinally across a two samples.

Consistent with the hypothesized directionality, there was a direct causal relationship between alcohol problems and depressive symptoms, **such that alcohol**

problems predicted depressive symptoms six months and one year later, but not three months later (as evidenced by the Student Study). It is important to note, however, that the relationship between alcohol use and depressive symptoms tended to be stronger for older populations, which is consistent with previous research (Brière et al., 2014; Conner, 2011), and which may also explain why this effect was not detected in the longitudinal analyses in the Student Study, where 84% of participants were between the ages of 18-24. There is actually evidence that moderate drinking at younger ages is typical and may signal normative social behaviour (Schleider et al., 2019). At the same time, however, disordered and problematic drinking was lower in the student sample than would be expected. A closer review of the demographic make-up of this sample indicated that 44% were students of Asian descent, many of whom were international students. Asian countries are known to have a lower prevalence of AUDs, between 3 and 4%, (Chen, Cochrane, Conigrave, & Hao, 2003). In this sample, the Asian participants had statistically significantly lower levels of alcohol problems on the AUDIT and RAPI, which reduced the overall scores. Therefore, these findings likely underestimate the relationship between problematic drinking and depressive symptoms in North America generally.

Hazardous drinking, which is characterized by the amount and frequency of alcohol use did predict depressive symptoms six months later, but not one year later. Again, previous research has found a predictive relationship between hazardous levels of alcohol consumption and depressive symptoms in the short-term, but not the long-term (e.g., Aneshensel & Huba, 1983b). Consistent with previous studies in university samples (e.g., Tremblay & Pulford, 2009), hazardous drinking did not predict depressive symptoms in

the student sample, over three months. **Importantly, alcohol problems, as compared to alcohol consumption, were a stronger predictor of depressive symptoms and significantly predicted depressive symptoms both six months and one year later.** The alternative models did not find any evidence that depressive symptoms predicted alcohol problems over one year. **Therefore, there is strong evidence that the long-term relationship between these variables is one where alcohol problems significantly predict depressive symptoms one-year later, rather than the other way around.** This finding is also consistent with previous research showing either no relationship or a negative relationship between alcohol use and depressive symptoms in shorter time frames (Aneshensel & Huba, 1983b; Schleider et al., 2019), and more evidence for a causal path from alcohol problems to depressive symptoms over one to four years (e.g., Aneshensel & Huba, 1983a, 1983a; Boden & Fergusson, 2011; Fergusson et al., 2009; Gilman & Abraham, 2001; Lee et al., 2018).

Specifically, the social and occupational consequences of alcohol use, surfaced as the strongest long-term predictor of depressive symptoms, especially after one-year, for both men and women. This finding is consistent with the emerging evidence that the impairment caused by alcohol use disorders accounts for a large proportion of the variance in the relationship between alcohol use disorder symptoms and depressive symptoms. **The overall relationship between alcohol problems and depressive symptoms one-year later (based on total RAPI scores) was only significant for women.** There are several possible reasons for these findings.

Empirical studies have found that women who drink socially are more negatively influenced by the effects of alcohol compared to men. For example, data show that even

moderate increases in alcohol consumption during social events were associated with increased symptoms of depression and anxiety in the following hours (Bimbaum, Taylor, & Parker, 1983; Bjork, Dougherty, & Moeller, 1999). Women with alcohol use disorders also tend to have more psychological difficulties overall, compared to men (Preuss & Wong, 2000); including a rates of phobias, posttraumatic stress disorder, mood disorders, and anxiety disorders, that are two-to-three times the rates of the same disorders among men (Regier et al., 1990; Schuckit et al., 1997). These are important findings, with important implications. While men experience AUDs at a greater rate than women, overall, (Cooper et al., 1992; King, Bernardy, & Hauner, 2003), women who experience AUDs tend to suffer from far greater levels of internalizing disorders compared to men, and these internalizing disorders appear to be directly associated with their alcohol use.

Two processes may be at play here. First, given that women tend to appraise problems as being more serious, compared to men (Tamres, Janicki, & Helgeson, 2002), it is possible that women perceive their drinking as creating more problems in their lives compared to men. This discrepancy in appraisal may more negatively influence women's psychological well-being compared to men's well-being. In contrast, men are more likely to minimize their problems and distract themselves from current stressors, which has been found to reduce their propensity for depression (Roelofs et al., 2009).

Further, there may be more stress-generation and ruminating about current stressors on the part of women compared to men (Hammen, 1991; Holahan, Moos, Holahan, Brennan, & Schutte, 2005; Liu & Alloy, 2010). Women with AUDs, compared to men with AUDs, are more likely to marry individuals who are cold, domineering, and who are often struggling with alcohol use disorders themselves (for a review, see Beckman,

1975). Women who drinking heavily are also more likely to be victims of physical and sexual assault, and are more likely to drink following being assaulted (Kaysen, 2007; Leeies, Pagura, Sareen, & Bolton, 2010). Theories related to this comorbidity among women also suggest that women engage in more avoidance coping (e.g., rumination, drinking) when problems arise compared to men, and that avoidance coping is directly related to their depressive symptoms.

For example, a 10-year longitudinal study assessing the stress-generating role of avoidance coping in predicting future depressive symptoms among 1,211 late-middle-aged individuals found that women who engaged in avoidance coping were more likely to experience depressive symptoms compared to men, and that this link was more likely to be direct and causal for women compared to men (Holahan et al., 2005). Alcohol use is a common form of avoidance coping, and drinking in order to cope has been shown to predict depressive symptoms over multi-year periods (Holahan, Moos, Holahan, Cronkite, & Randall, 2001).

To help assess the possibility that alcohol is used as a means of avoidance coping in general, motivations for drinking, which have been increasingly incorporated into the research on AUDs (e.g., Cooper, 1994; Cooper, Frone, Russell, & Mudar, 1995; Cooper et al., 1992; Foster et al., 2014; A. L. Goldstein, Wall, McKee, & Hinson, 2004), were also added into a final model of the Student Study. In this exploratory model, drinking to cope surfaced as a significant predictor of alcohol-related problems over a three-month period. Therefore, there is empirical evidence for this hypothesis. Due to limitations in sample size, an analyses of sex differences could not be completed, and future research is needed to fill in this gap.

The propensity to cope using avoidance strategies (e.g., drinking, distracting) may also be causing alcohol problems and depressive symptoms to cycle. Although alcohol problems predict depressive symptoms over longer time frames, evidence from this dissertation also suggests that symptoms of these disorders perpetuate each other in six-month time frames. Alternative models tested in this dissertation indicated similar three-month and six-month paths in both directions (from depressive symptoms to alcohol problems and vice versa). In the Community Study, there was equal evidence that depressive symptoms significantly predicted alcohol problems and that alcohol problems predicted depressive symptoms over six months. The paths in both directions were approximately equal in size. **Therefore, over six-month time frames, there is likely a reciprocal relationship between depressive symptoms and alcohol problems, such that they influence and exacerbate each other.** There were no sex differences in this relationship.

Alcohol use disorders among men have received a much larger proportion of the literature in this area, not because they lead to more problems for men, but because they lead to more severe externalizing problems, such as aggression towards others (M. F. Tomlinson, Brown, & Hoaken, 2016), as well as more problems for society, such as criminal behaviour (Bennett & Holloway, 2005). However, the finding that women experience more psychiatric difficulties related to alcohol-related problems is an important finding. Clinicians working with men and women experiencing comorbid AUD and MDD are encouraged to prioritize understanding how the alcohol use is affecting their client's lives, what externalizing and internalizing problems are caused by drinking, and what problems are perpetuating drinking (i.e., what problems are they using alcohol

to avoid). Helping clients identify these problems and engage in more active coping (e.g., problem solving) and alternative means of reducing the physiological arousal caused by these problems (e.g., self-soothing strategies) may mitigate consequent depressive symptoms.

Treating both disorder simultaneously by understanding and treating the underlying externalizing and internalizing problems surrounding these disorders may also have a significant positive impact on society. For example, both problematic alcohol use and psychological distress have a significant impact on economic growth, individual productivity, disability claims, and interpersonal conflict (Gotlib & Hammen, 2014; M. F. Tomlinson et al., 2016). Understanding the commonalities of these disorders and helping clients navigate the difficulties that their disorders are causing may meaningfully assist them in living full, meaningful, and productive lives; and in contributing more to society.

Given the substantive evidence against the Self-Medication Hypothesis from this dissertation and previous research (Lembke, 2012), and the increasing evidence of a causal path from alcohol problems to depressive symptoms, an updated theoretical explanation is needed. This dissertation proposed that cognitive variables influence the relationship between alcohol problems and depressive symptoms. There was evidence from both studies that distorted cognitive processes mediated the relationship between alcohol use and depressive symptoms. However, this effect was not consistent over time frames, and only periodically emerged. In the Student Study, this mediational effect emerged over a three-month period but in the absence of a direct relationship between alcohol problems and depressive symptoms.

Further, when distorted cognitive functioning was added into the model as a latent variable comprised of ruminative thinking, negative information processing, and dysfunctional attitudes, cross-sectional analysis found these variables to mediate the overall relationship between alcohol problems and depressive symptoms. In longitudinal models, there was no evidence that ruminative thinking mediated this relationship. Ruminative thinking was significantly associated alcohol withdrawal and with depressive symptoms, although these associations were small.

A closer review of how dysfunctional attitudes, specifically, related to both depressive symptoms and alcohol problems demonstrated a stronger relationship between depressive symptoms and alcohol problems, and a much weaker, relationship between dysfunctional attitudes and alcohol problems. Dysfunctional attitudes may have a larger role in perceptions of difficulties, avoidance coping, and stress-generation, which may motivate and exacerbate drinking problems, rather than in directly predicting difficulties with drinking.

In the Student Study, the simple longitudinal paths from cognitive depressive symptoms to dysfunctional attitudes ($b = .18$) and from dysfunctional attitudes to cognitive depressive symptoms ($b = .21$) were largely comparable. In the Community Study, depressive symptoms were far stronger predictors of dysfunctional attitudes compared to the other way around, and this effect was consistent across multiple time-lags. Thus, while there is some evidence that these variables have a reciprocal relationship, there is far more evidence over time that depressive symptoms predict dysfunctional attitudes than vice versa.

Results from the Student Study also point to evidence for a third variable hypothesis whereby cognitive variables predict both alcohol problems and depressive symptoms. Specifically, although negatively-biased information processing was not strongly associated with alcohol measures cross-sectionally, it did surface as a significant predictor of alcohol problems three months later. Negative information processing also surfaced as a significant predictor of depressive symptoms, and depressive symptoms surfaced as a strong and significant predictor of negatively-biased information processing.

Therefore, negative information processing as a trait-level characteristic may cause both increases in depressive symptoms and increases in alcohol-related problems. Depressive symptoms, in turn, may perpetuate an individual's tendency to process information in a negatively-biased way. There were no sex differences in this relationship. Clinicians treating individuals with both AUD and MDD may target these negatively-biased ways of interpreting incoming information as a means of mitigating both symptoms of depression and an individual's interpretation of the consequences of their drinking. By helping individuals to process information in a more balanced and accurate way, as emphasized in psychotherapeutic approaches such as Cognitive Behaviour Therapy (Beck, 1963), clients may become more accurate in their interpretation of current stressors, and combined with more active coping strategies (e.g., problem solving, actively addressing interpersonal conflict), may learn to break-down and problem-solve the challenges with which they are faced. In this process, clients may learn to prevent or mitigate resulting depressive symptoms.

In summary, evidence from this dissertation suggests that alcohol problems and depressive symptoms are not strongly related at 3-month intervals, demonstrate a reciprocal relationship at six-month intervals, and have a causal unidirectional relationship at one-year intervals, whereby alcohol problems cause depressive symptoms. There is some evidence that dysfunctional attitudes mediate this relationship, and there is some evidence that negative-information processing bias predicts both depressive symptoms and alcohol-related problems. Ruminative thinking is not related to alcohol problems over time and is strongly related to depressive symptomatology.

While many hypotheses were supported to some degree in the community and student studies, the paths were rarely consistent across time, and the hypothesized mediation effect was only present in one six-month interval. There are three potential explanations for these findings that warrant discussion. First, it is possible that the cross-sectional mediational findings were not consistently replicated in the longitudinal model due to problems with the distance between time points. Three-month time intervals may be either too long or too short to detect sufficient covariance among these three variables, and to detect mediating effects. Further, there may be sex differences in the optimal time-lags. In the cross-sectional models, there was clear evidence that the indirect effect of dysfunctional attitudes on the relationship between alcohol problems and depressive symptoms was stronger for women compared to men. This effect was not replicated in longitudinal analyses. Further, there was no evidence that this effect surfaced in the models tested with women and men separately. However, given how small the longitudinal indirect effect was, it is possible that only the full model (with all participants included) had sufficient power to detect the effect.

It is possible that future studies assessing changes over hours, days, weeks, or years would show more variability in these variables and better capture how changes in dysfunctional attitudes may influence these variables among women. The second possible explanation is that dysfunctional attitudes do not represent the cognitive variables that may influence the relationship between alcohol problems and depressive symptoms. The majority of research on alcohol use and cognitive variables is separate from the research on depressive symptoms and cognitive variables. Therefore, there has been strikingly little investigation of how these variables may influence alcohol use and depressive symptoms, and far more research on how cognitive variables may influence depressive symptoms (Beck & Bredemeier, 2016; Dobson & Shaw, 1987b; Halvorsen et al., 2010) or how cognitive variables influence alcohol problems (Caselli et al., 2010; Gjestad et al., 2011; Read et al., 2003), separately.

Thus, it was challenging to determine which cognitive variables to include in this mediation model. Further, given that the majority of this research has been cross-sectional rather than longitudinal, there is little information on how these variables naturally fluctuate over time. It is possible that more general distorted cognitive processes (e.g., negative information processing bias), which do not need to be activated by sad mood, are more influential in perpetuating and predicting the relationship between alcohol problems and depression in more of a third-variable role. There is research suggesting that negative-biased information processing remits following periods of remission from depression, and may predict depressive symptoms over time (Dobson & Shaw, 1987b). Future research is needed to further map the trajectory of cognitive

variables over time, and to determine how these variables may be influenced by stressful life events, as well as stressful events caused by problematic drinking.

Two major limitations of this dissertation also warrant discussion. First, the substantial attrition seen in both studies points to the logistical difficulties of longitudinal research. In the Community Study, almost 50% of participants were lost over the course of the year. In the Student Study, approximately 30% were lost over three months. Therefore, future studies in this area are encouraged to over-sample by approximately 100% to account for the significant attrition seen in longitudinal research. Additionally, the significant attrition present in both studies may have influenced the findings. While attrition did not appear to be associated with either depressive symptoms or alcohol problems in the Student Study, it was associated with these key variables in the Community Study. Individuals who struggled more with both depression and alcohol problems in the Community Study inconsistently participated over time. This limitation may partially explain the inconsistent findings across time points.

Second, only dysfunctional attitudes were assessed in the community sample, which prevented an evaluation of other cognitive variables, such as rumination and negative information processing bias, among older and more diverse samples. Future studies are needed to map the trajectory of other cognitive variables in more diverse samples, and to assess their relationship with alcohol-related problems specifically, as well as their relationship with depressive symptoms over time.

Alcohol is the most commonly abused drug worldwide⁵, and has been for hundreds of years (M. F. Tomlinson et al., 2016). Although alcohol often conjures images of

⁵ Alcohol is preceded only by caffeine and nicotine as the most used drugs worldwide.

celebration, amusement, and joy, the effects of alcohol, such as disinhibition, depressed affect, and increased aggressive behaviour can also lead to significant problems among individuals who use the substance problematically (Boden & Fergusson, 2011; M. F. Tomlinson et al., 2016). Many individuals with AUDs also experience other psychiatric difficulties comorbidly. The findings from this dissertation should be implemented in intervention and prevention programs that focus on more comprehensively understanding the impairment caused by alcohol use and depressive symptoms and using cognitively-based (e.g., thought records, re-framing, balanced-thinking) and behavioural (problem-solving, activity-planning, self-soothing) strategies to help mitigate the impairment caused by these disorders. Treating both disorders using the common underlying factors that contribute to both is expected to help clients live healthier lives.

References

- Abas, M. A., Sahakian, B. J., & Levy, R. (1990). Neuropsychological deficits and CT scan changes in elderly depressives. *Psychological Medicine, 20*, 507–520.
- Abela, J. R. Z., & D'Alessandro, D. U. (2002). Beck's cognitive theory of depression: A test of the diathesis-stress and causal mediation components. *British Journal of Clinical Psychology, 41*, 111–128. <https://doi.org/10.1348/014466502163912>
- Allan, C. A., & Cooke, D. J. (1985). Stressful life events and alcohol misuse in women: A critical review. *Journal of Studies on Alcohol, 46*, 147–152. <https://doi.org/10.15288/jsa.1985.46.147>
- Allen, J. P., Litten, R. Z., Fertig, J. B., & Babor, T. (1997). A review of research on the Alcohol Use Disorders Identification Test (AUDIT). *Alcoholism: Clinical and Experimental Research, 21*, 613–619. <https://doi.org/10.1111/j.1530-0277.1997.tb03811.x>
- Anda, R. F., Whitfield, C. L., Felitti, V. J., Chapman, D., Edwards, V. J., Dube, S. R., & Williamson, D. F. (2002). Adverse childhood experiences, alcoholic parents, and later risk of alcoholism and depression. *Psychiatric Services, 53*, 1001–1009. <https://doi.org/10.1176/appi.ps.53.8.1001>
- Aneshensel, C. S., & Huba, G. J. (1983a). An integrative causal model of the antecedents and consequences of depression over one year. *Research in Community & Mental Health, 4*, 35–72.
- Aneshensel, C. S., & Huba, G. J. (1983b). Depression, alcohol use, and smoking over one year: A four-wave longitudinal causal model. *Journal of Abnormal Psychology, 92*, 134.

- APA. (2000). *Diagnostic and statistical manual of mental disorders* (4th edition, text revision). Washington, DC: Author.
- APA. (2013). *Diagnostic and statistical manual of mental disorders* (5th edition). Washington, DC: Author.
- Archie, S., Zangeneh Kazemi, A., & Akhtar-Danesh, N. (2012). Concurrent binge drinking and depression among Canadian youth: Prevalence, patterns, and suicidality. *Alcohol, 46*, 165–172. <https://doi.org/10.1016/j.alcohol.2011.07.001>
- Armeli, S., Conner, T. S., Cullum, J., & Tennen, H. (2010). A longitudinal analysis of drinking motives moderating the negative affect-drinking association among college students. *Psychology of Addictive Behaviors, 24*, 38–47.
- Asberg, M., Thoren, P., Traskman, L., Bertilsson, L., & Ringberger, V. (1976). ‘Serotonin depression’ - a biochemical subgroup within the affective disorders? *Science, 191*, 478–480.
- Austin, M.-P., Mitchell, P., & Goodwin, G. (2001). Cognitive deficits in depression. *The British Journal of Psychiatry, 178*, 200–206.
<https://doi.org/10.1192/bjp.178.3.200>
- Baron, R. M., & Kenny, D. A. (1986). The moderator–mediator variable distinction in social psychological research: Conceptual, strategic, and statistical considerations. *Journal of Personality and Social Psychology, 51*, 1173–1182.
- Barrett, P. (2007). Structural equation modelling: Adjudging model fit. *Personality and Individual Differences, 42*, 815–824.

- Beck, A. T. (1963). Thinking and depression: I. idiosyncratic content and cognitive distortions. *Archives of General Psychiatry*, *9*, 324–333.
<https://doi.org/10.1001/archpsyc.1963.01720160014002>
- Beck, A. T. (1993). Cognitive therapy: Nature and relation to behavior therapy. *The Journal of Psychotherapy Practice and Research*, *2*, 342–342.
- Beck, A. T. (2008). The evolution of the cognitive model of depression and its neurobiological correlates. *The American Journal of Psychiatry*, *165*, 969–977.
<https://doi.org/10.1176/appi.ajp.2008.08050721>
- Beck, A. T., & Bredemeier, K. (2016). A unified model of depression: Integrating clinical, cognitive, biological, and evolutionary perspectives. *Clinical Psychological Science*, *4*(4), 596–619.
- Beck, A. T., Steer, R. A., & Brown, G. K. (1996). *Beck depression inventory-II*. San Antonio, TX: The Psychological Cooperation.
- Beckman, L. J. (1975). Women alcoholics. A review of social and psychological studies. *Journal of Studies on Alcohol*, *36*, 797–824.
<https://doi.org/10.15288/jsa.1975.36.797>
- Beiter, R., Nash, R., McCrady, M., Rhoades, D., Linscomb, M., Clarahan, M., & Sammut, S. (2015). The prevalence and correlates of depression, anxiety, and stress in a sample of college students. *Journal of Affective Disorders*, *173*, 90–96.
<https://doi.org/10.1016/j.jad.2014.10.054>
- Bellos, S., Skapinakis, P., Rai, D., Zitko, P., Araya, R., Lewis, G., ... Mavreas, V. (2016). Longitudinal association between different levels of alcohol consumption and a new onset of depression and generalized anxiety disorder: Results from an

international study in primary care. *Psychiatry Research*, 243, 30–34.

<https://doi.org/10.1016/j.psychres.2016.05.049>

Bennett, T., & Holloway, K. (2005). *Understanding drugs, alcohol and crime*. McGraw-Hill Education (UK).

Berger, B. D., & Adesso, V. J. (1991). Gender differences in using alcohol to cope with depression. *Addictive Behaviors*, 16(5), 315–327. [https://doi.org/10.1016/0306-4603\(91\)90024-C](https://doi.org/10.1016/0306-4603(91)90024-C)

Bimbaum, I. M., Taylor, T. H., & Parker, E. S. (1983). Alcohol and sober mood state in female social drinkers. *Alcoholism: Clinical and Experimental Research*, 7, 362–368. <https://doi.org/10.1111/j.1530-0277.1983.tb05483.x>

Birkmayer, W., & Riederer, P. (1975). Biochemical post-mortem findings in depressed patients. *Journal of Neural Transmission*, 37, 95–109. <https://doi.org/10.1007/BF01663627>

Bjork, J. M., Dougherty, D. M., & Moeller, F. G. (1999). Symptomatology of depression and anxiety in female “social drinkers”. *The American Journal of Drug and Alcohol Abuse*, 25, 173–182.

Blum, K., Noble, E., Sheridan, P., Montgomery, A., Ritchie, T., Jagadeeswaran, P., ... Cohn. (1990). Allelic association of human dopamine D2 receptor gene in alcoholism. *JAMA*, 263, 2055–2060. <https://doi.org/10.1001/jama.1990.03440150063027>

Bockting, C. L., Hollon, S. D., Jarrett, R. B., Kuyken, W., & Dobson, K. (2015). A lifetime approach to major depressive disorder: The contributions of

- psychological interventions in preventing relapse and recurrence. *Psychological Interventions for Depression*, *41*, 16–26. <https://doi.org/10.1016/j.cpr.2015.02.003>
- Boden, J. M., & Fergusson, D. M. (2011). Alcohol and depression. *Addiction*, *106*, 906–914. <https://doi.org/10.1111/j.1360-0443.2010.03351.x>
- Bohn, M. J., Babor, T. F., & Kranzler, H. R. (1995). The alcohol use disorders identification test (AUDIT): Validation of a screening instrument for use in medical settings. *Journal of Studies on Alcohol*, *56*, 423–432. <https://doi.org/10.15288/jsa.1995.56.423>
- Boschloo, L., Vogelzangs, N., Smit, J. H., van den Brink, W., Veltman, D. J., Beekman, A. T. F., & Penninx, B. W. J. H. (2011). Comorbidity and risk indicators for alcohol use disorders among persons with anxiety and/or depressive disorders. *Journal of Affective Disorders*, *131*, 233–242. <https://doi.org/10.1016/j.jad.2010.12.014>
- Boschloo, L., Vogelzangs, N., van den Brink, W., Smit, J. H., Veltman, D. J., Beekman, A. T. F., & Penninx, B. W. J. H. (2012). Alcohol use disorders and the course of depressive and anxiety disorders. *The British Journal of Psychiatry*, *200*, 476–484. <https://doi.org/10.1192/bjp.bp.111.097550>
- Brambilla, P., Perez, J., Barale, F., Schettini, G., & Soares, J. (2003). GABAergic dysfunction in mood disorders. *Molecular Psychiatry*, *8*, 721–737.
- Brière, F. N., Rohde, P., Seeley, J. R., Klein, D., & Lewinsohn, P. M. (2014). Comorbidity between major depression and alcohol use disorder from adolescence to adulthood. *Comprehensive Psychiatry*, *55*, 526–533. <https://doi.org/10.1016/j.comppsy.2013.10.007>

- Burt, D. B., Zembar, M. J., & Niederehe, G. (1995). Depression and memory impairment: A meta-analysis of the association, its pattern, and specificity. *Psychological Bulletin, 117*, 285–305. <https://doi.org/10.1037/0033-2909.117.2.285>
- Butler, L. D., & Nolen-Hoeksema, S. (1994). Gender differences in responses to depressed mood in a college sample. *Sex Roles, 30*(5), 331–346. <https://doi.org/10.1007/BF01420597>
- Cannon, B., Mulroy, R., Otto, M. W., Rosenbaum, J. F., Fava, M., & Nierenberg, A. A. (1999). Dysfunctional attitudes and poor problem solving skills predict hopelessness in major depression. *Journal of Affective Disorders, 55*, 45–49. [https://doi.org/10.1016/S0165-0327\(98\)00123-2](https://doi.org/10.1016/S0165-0327(98)00123-2)
- Carton, L., Pignon, B., Baguet, A., Benradia, I., Roelandt, J.-L., Vaiva, G., ... Rolland, B. (2018). Influence of comorbid alcohol use disorders on the clinical patterns of major depressive disorder: A general population-based study. *Drug and Alcohol Dependence, 187*, 40–47. <https://doi.org/10.1016/j.drugalcdep.2018.02.009>
- Caselli, G., Bortolai, C., Leoni, M., Rovetto, F., & Spada, M. M. (2008). Rumination in problem drinkers. *Addiction Research & Theory, 16*, 564–571.
- Caselli, G., Ferretti, C., Leoni, M., Rebecchi, D., Rovetto, F., & Spada, M. M. (2010). Rumination as a predictor of drinking behaviour in alcohol abusers: A prospective study. *Addiction, 105*, 1041–1048.
- Caspi, A., Sugden, K., Moffitt, T. E., Taylor, A., Craig, I. W., Harrington, H., ... Braithwaite, A. (2003). Influence of life stress on depression: Moderation by a polymorphism in the 5-HTT gene. *Science, 301*, 386–389.

- Chabon, B., & Robins, C. J. (1986). Cognitive distortions among depressed and suicidal drug abusers. *International Journal of the Addictions, 21*, 1313–1329.
- Chastain, G. (2006). Alcohol, neurotransmitter systems, and behavior. *The Journal of General Psychology, 133*, 329–335.
- Chen, H., Cochrane, J., Conigrave, K. M., & Hao, W. (2003). Alcohol use in China. *Alcohol and Alcoholism, 38*(6), 537–542. <https://doi.org/10.1093/alcalc/agg111>
- Clark, D. M. (1983). On the induction of depressed mood in the laboratory: Evaluation and comparison of the Velten and musical procedures. *Advances in Behaviour Research and Therapy, 5*, 27–49.
- Cohen, J. (1988). *Statistical power analysis for the behavioural sciences*. New Jersey: Lawrence Erlbaum Associates.
- Colder, C. R. (2001). Life stress, physiological and subjective indexes of negative emotionality, and coping reasons for drinking: Is there evidence for a self-medication model of alcohol use? *Psychology of Addictive Behaviors, 15*, 237–245. <https://doi.org/10.1037/0893-164X.15.3.237>
- Cole, D. A., & Maxwell, S. E. (2003). Testing mediational models with longitudinal data: Questions and tips in the use of structural equation modeling. *Journal of Abnormal Psychology, 112*, 558–577.
- Conger, J. J. (1956). Alcoholism: Theory, problem and challenge. II. Reinforcement theory and the dynamics of alcoholism. *Quarterly Journal of Studies On Alcohol, 17*, 296–305.
- Conner, K. R. (2011). Clarifying the relationship between alcohol and depression. *Addiction, 106*, 915–916. <https://doi.org/10.1111/j.1360-0443.2011.03385.x>

- Conner, K. R., Piquart, M., & Gamble, S. A. (2009). Meta-analysis of depression and substance use among individuals with alcohol use disorders. *Journal of Substance Abuse Treatment, 37*, 127–137. <https://doi.org/10.1016/j.jsat.2008.11.007>
- Connolly, G. M., Casswell, S., Zhang, J.-F., & Silva, P. A. (1994). Alcohol in the mass media and drinking by adolescents: A longitudinal study. *Addiction, 89*, 1255–1263. <https://doi.org/10.1111/j.1360-0443.1994.tb03304.x>
- Cooper, M. L. (1994). Motivations for alcohol use among adolescents: Development and validation of a four-factor model. *Psychological Assessment, 6*, 117–128. <https://doi.org/10.1037/1040-3590.6.2.117>
- Cooper, M. L., Frone, M. R., Russell, M., & Mudar, P. (1995). Drinking to regulate positive and negative emotions: A motivational model of alcohol use. *Journal of Personality and Social Psychology, 69*, 990–1005.
- Cooper, M. L., Russell, M., Skinner, J. B., Frone, M. R., & Mudar, P. (1992). Stress and alcohol use: Moderating effects of gender, coping, and alcohol expectancies. *Journal of Abnormal Psychology, 101*, 139.
- Cowan, J. D. (1983). Testing the escape hypotheses: Alcohol helps users to forget their feelings. *Journal of Nervous and Mental Disease, 171*(1), 40–48. <https://doi.org/10.1097/00005053-198301000-00008>
- Craighead, W. E., Sheets, E. S., Craighead, L. W., & Madsen, J. W. (2011). Recurrence of MDD: A prospective study of personality pathology and cognitive distortions. *Personality Disorders: Theory, Research, and Treatment, 2*, 83–97. <https://doi.org/10.1037/a0020456>

- Crum, R. M., Mojtabai, R., Lazareck, S., Bolton, J. M., Robinson, J., Sareen, J., ... Storr, C. L. (2013). A prospective assessment of reports of drinking to self-medicate mood symptoms with the incidence and persistence of alcohol dependence. *JAMA Psychiatry, 70*, 718–726. <https://doi.org/10.1001/jamapsychiatry.2013.1098>
- Cryan, J. F., & Kaupmann, K. (2005). Don't worry 'B' happy!: A role for GABAB receptors in anxiety and depression. *Trends in Pharmacological Sciences, 26*, 36–43. <https://doi.org/10.1016/j.tips.2004.11.004>
- Davis, L., Uezato, A., Newell, J. M., & Frazier, E. (2008). Major depression and comorbid substance use disorders. *Current Opinion in Psychiatry, 21*, 14–18.
- Dawson, D. A., Grant, B., Stinson, F., Chou, P., & Huang, B. (2005). Recovery from DSM-IV alcohol dependence: United States, 2001-2002. *Addiction (Abingdon, England), 100*, 281–292. <https://doi.org/10.1111/j.1360-0443.2004.00964.x>
- Derry, P. A., & Kuiper, N. A. (1981). Schematic processing and self-reference in clinical depression. *Journal of Abnormal Psychology, 90*, 286–297.
- Dick, D. M., Aliev, F., Viken, R., Kaprio, J., & Rose, R. J. (2011). Rutgers Alcohol Problem Index Scores at age 18 predict alcohol dependence diagnoses 7 years later. *Alcoholism: Clinical and Experimental Research, 35*, 1011–1014. <https://doi.org/10.1111/j.1530-0277.2010.01432.x>
- Dickter, C. L., Forestell, C. A., Hammett, P. J., & Young, C. M. (2014). Relationship between alcohol dependence, escape drinking, and early neural attention to alcohol-related cues. *Psychopharmacology, 231*(9), 2031–2040.
- Dixit, A. R., & Crum, R. M. (2000). Prospective study of depression and the risk of heavy alcohol use in women. *The American Journal of Psychiatry, 157*, 751–758.

Retrieved from Nursing & Allied Health Database; Research Library.
(220509763; 10784468; 20246926)

- Dobson, K. S., & Shaw, B. F. (1986). Cognitive assessment with major depressive disorders. *Cognitive Therapy and Research, 10*, 13–29.
- Dobson, K. S., & Shaw, B. F. (1987a). Specificity and stability of self-referent encoding in clinical depression. *Journal of Abnormal Psychology, 96*, 34–40.
- Dobson, K. S., & Shaw, B. F. (1987b). Specificity and stability of self-referent encoding in clinical depression. *Journal of Abnormal Psychology, 96*(1), 34–40.
<https://doi.org/10.1037/0021-843X.96.1.34>
- Dozois, D. J. A., Dobson, K. S., & Ahnberg, J. L. (1998). A psychometric evaluation of the Beck Depression Inventory–II. *Psychological Assessment, 10*, 83–89.
- Eaton, W. W., Shao, H., Nestadt, G., Lee, B. H., Bienvenu, O. J., & Zandi, P. (2008). Population-based study of first onset and chronicity in major depressive disorder. *Archives of General Psychiatry, 65*, 513–520.
<https://doi.org/10.1001/archpsyc.65.5.513>
- Ehring, T., Kleim, B., & Ehlers, A. (2011). Combining clinical studies and analogue experiments to investigate cognitive mechanisms in posttraumatic stress disorder. *International Journal of Cognitive Therapy, 4*(2), 165–177.
<https://doi.org/10.1521/ijct.2011.4.2.165>
- Epkins, C. C. (2000). Cognitive specificity in internalizing and externalizing problems in community and clinic-referred children. *Journal of Clinical Child Psychology, 29*, 199–208.

- Fergusson, D. M., Boden, J. M., & Horwood, L. J. (2009). Tests of causal links between alcohol abuse or dependence and major depression. *Archives of General Psychiatry*, *66*, 260–266.
- Field, A. (2013). *Discovering statistics using IBM SPSS statistics: And sex and drugs and rock'n'roll*. London, UK: Sage.
- Foo, J. C., Streit, F., Treutlein, J., Ripke, S., Witt, S. H., Strohmaier, J., ... Soyka, M. (2018). Shared genetic etiology between alcohol dependence and major depressive disorder. *Psychiatric Genetics*, *28*, 66–70.
- Forestell, C. A., Dickter, C. L., & Young, C. M. (2012). Take me away: The relationship between escape drinking and attentional bias for alcohol-related cues. *Alcohol*, *46*(6), 543–549.
- Foster, D. W., Young, C. M., Steers, M.-L. N., Quist, M. C., Bryan, J. L., & Neighbors, C. (2014). Tears in your beer: Gender differences in coping drinking motives, depressive symptoms and drinking. *International Journal of Mental Health and Addiction*, *12*, 730–746.
- Freed, E. X. (1978). Alcohol and mood: An updated review. *International Journal of the Addictions*, *13*, 173–200. <https://doi.org/10.3109/10826087809039273>
- Gémes, K., Forsell, Y., Janszky, I., László, K. D., Lundin, A., Ponce De Leon, A., ... Möller, J. (2019). Moderate alcohol consumption and depression—a longitudinal population-based study in Sweden. *Acta Psychiatrica Scandinavica*, Online Pre-Print.
- Giancola, P. R., Mezzich, A. C., Clark, D. B., & Tarter, R. E. (1999). Cognitive distortions, aggressive behavior, and drug use in adolescent boys with and without

a family history of a substance use disorder. *Psychology of Addictive Behaviors*, 13, 22–32. <https://doi.org/10.1037/0893-164X.13.1.22>

- Giancola, P. R., & Zeichner, A. (1997). The biphasic effects of alcohol on human physical aggression. *Journal of Abnormal Psychology*, 106, 598.
- Gillies, J. C. P. (2018). *Trajectories of the effects of sad mood induction procedures (MIPs)* (Master's Thesis). University of Western Ontario, London, ON.
- Gilman, S. E., & Abraham, H. D. (2001). A longitudinal study of the order of onset of alcohol dependence and major depression. *Drug and Alcohol Dependence*, 63, 277–286. [https://doi.org/10.1016/S0376-8716\(00\)00216-7](https://doi.org/10.1016/S0376-8716(00)00216-7)
- Gjestad, R., Franck, J., Hagtvet, K. A., & Haver, B. (2011). Level and change in alcohol consumption, depression and dysfunctional attitudes among females treated for alcohol addiction. *Alcohol and Alcoholism*, 46, 292–300.
- Goldstein, A. L., Wall, A.-M., McKee, S. A., & Hinson, R. E. (2004). Accessibility of alcohol expectancies from memory: Impact of mood and motives in college student drinkers. *Journal of Studies on Alcohol*, 65, 95–104.
- Goldstein, B. L., Hayden, E. P., & Klein, D. N. (2015). Stability of self-referent encoding task performance and associations with change in depressive symptoms from early to middle childhood. *Cognition and Emotion*, 29, 1445–1455. <https://doi.org/10.1080/02699931.2014.990358>
- Görizt, A. S., & Moser, K. (2006). Web-based mood induction. *Cognition and Emotion*, 20, 887–896.
- Gotlib, I. H., & Hammen, C., L. (2014). *Handbook of Depression* (3rd ed., Vol. 1). New York, NY: Guilford Press.

- Grant, B. F., Hasin, D. S., & Dawson, D. A. (1995). The relationship between DSM-IV alcohol use disorders and DSM-IV major depression: Examination of the primary-secondary distinction in a general population sample. *Journal of Affective Disorders, 38*(2–3), 113–128. [https://doi.org/10.1016/0165-0327\(96\)00002-X](https://doi.org/10.1016/0165-0327(96)00002-X)
- Hall, D. H., & Queener, J. E. (2007). Self-Medication Hypothesis of Substance Use: Testing Khantzian's Updated Theory. *Journal of Psychoactive Drugs, 39*, 151–158. <https://doi.org/10.1080/02791072.2007.10399873>
- Halvorsen, M., Wang, C. E., Eisemann, M., & Waterloo, K. (2010). Dysfunctional attitudes and early maladaptive schemas as predictors of depression: A 9-year follow-up study. *Cognitive Therapy and Research, 34*, 368–379. <https://doi.org/10.1007/s10608-009-9259-5>
- Hammen, C. (1991). Generation of stress in the course of unipolar depression. *Journal of Abnormal Psychology, 100*, 555–561. <https://doi.org/10.1037/0021-843X.100.4.555>
- Hammen, C., & Zupan, B. A. (1984). Self-schemas, depression, and the processing of personal information in children. *Journal of Experimental Child Psychology, 37*, 598–608. [https://doi.org/10.1016/0022-0965\(84\)90079-1](https://doi.org/10.1016/0022-0965(84)90079-1)
- Hankin, B. L. (2008). Stability of cognitive vulnerabilities to depression: A short-term prospective multiwave study. *Journal of Abnormal Psychology, 117*, 324.
- Hartka, E., Johnstone, B., Leino, E. V., Motoyoshi, M., Temple, M. T., & Fillmore, K. M. (1991). A meta-analysis of depressive symptomatology and alcohol consumption over time. *British Journal of Addiction, 86*, 1283–1298.

- Hashimoto, K. (2009). Emerging role of glutamate in the pathophysiology of major depressive disorder. *Brain Research Reviews*, *61*, 105–123.
- Hayden, E. P., Klein, D. N., Durban, E. C., & Olino, T. M. (2006). Positive emotionality at age 3 predicts cognitive styles in 7-year-old children. *Development and Psychopathology*, *18*, 409–423. <https://doi.org/10.1017/S0954579406060226>
- Heinz, A. J., Veilleux, J. C., & Kassel, J. D. (2009). The role of cognitive structure in college student problem drinking. *Addictive Behaviors*, *34*, 212–218.
- Hoaglin, D. C., Iglewicz, B., & Tukey, J. W. (1986). Performance of some resistant rules for outlier labeling. *Journal of the American Statistical Association*, *81*, 991–999. <https://doi.org/10.1080/01621459.1986.10478363>
- Holahan, C. J., Moos, R. H., Holahan, C. K., Brennan, P. L., & Schutte, K. K. (2005). Stress generation, avoidance coping, and depressive symptoms: A 10-year model. *Journal of Consulting and Clinical Psychology*, *73*(4), 658–666. <https://doi.org/10.1037/0022-006X.73.4.658>
- Holahan, C. J., Moos, R. H., Holahan, C. K., Cronkite, R. C., & Randall, P. K. (2001). Drinking to cope, emotional distress and alcohol use and abuse: A ten-year model. *Journal of Studies on Alcohol*, *62*, 190–198. <https://doi.org/10.15288/jsa.2001.62.190>
- Holahan, C. J., Schutte, K. K., Brennan, P. L., Holahan, C. K., & Moos, R. H. (2014). Episodic Heavy Drinking and 20-Year Total Mortality Among Late-Life Moderate Drinkers. *Alcoholism: Clinical and Experimental Research*, *38*(5), 1432–1438. <https://doi.org/10.1111/acer.12381>

- Hull, J. G., & Reilly, N. P. (1986). Information processing approach to alcohol use and its consequences. In *Personality, Psychopathology, and Psychotherapy Series. Information processing approaches to clinical psychology*. (pp. 151–167). Retrieved from <https://www.lib.uwo.ca/cgi-bin/ezpauthn.cgi?url=http://search.proquest.com/docview/617237693?accountid=15115>
- Hyslop, Theo. B., Reid, G. A., Mercier, C., Yellowlees, D., Kelynack, T. N., Edridge-Green, F., ... Jones, R. (1903). A discussion on alcohol in relation to mental disorders. *The British Medical Journal*, (2231), 816–822. Retrieved from JSTOR.
- Ingram, R. E. (1983). Depression and information processing: Self-schemata and the encoding of self-referent information. *Journal of Personality and Social Psychology*, 45(2), 412–420. <https://doi.org/10.1037/0022-3514.45.2.412>
- Ingram, R. E., & Reed, M. R. (1986). *Information encoding and retrieval processes in depression: Findings, issues, and future directions*. Academic Press.
- Jennings, P. D., McGinnis, D., Lovejoy, S., & Stirling, J. (2000). Valence and Arousal Ratings for Velten Mood Induction Statements. *Motivation and Emotion*, 24, 285–297. <https://doi.org/10.1023/A:1010745016868>
- Johnson, D. P., & Whisman, M. A. (2013). Gender differences in rumination: A meta-analysis. *Personality and Individual Differences*, 55, 367–374. <https://doi.org/10.1016/j.paid.2013.03.019>
- Johnson, K. A., Johnson, J. E., & Petzel, T. P. (1992). Social anxiety, depression, and distorted cognitions in college students. *Journal of Social and Clinical Psychology*, 11, 181.

- Judd, C. M., & Kenny, D. A. (1981). Process analysis: Estimating mediation in treatment evaluations. *Evaluation Review*, (5), 602–619.
- Kahler, C. W., Ramsey, S. E., Read, J. P., & Brown, R. A. (2002). Substance-induced and independent major depressive disorder in treatment-seeking alcoholics: Associations with dysfunctional attitudes and coping. *Journal of Studies on Alcohol*, 63, 363–371. Retrieved from PsycINFO. (619738293; 2002-01967-013)
- Kaysen, D. (2007). Domestic violence and alcohol use: Trauma-related symptoms and motives for drinking. *Addictive Behaviors*, 32(6), 1272–1283.
<https://doi.org/10.1016/j.addbeh.2006.09.007>
- Kempton, T., Van Hasselt, V. B., Bukstein, O. G., & Null, J. A. (1994). Cognitive distortions and psychiatric diagnosis in dually diagnosed adolescents. *Journal of the American Academy of Child & Adolescent Psychiatry*, 33, 217–222.
- Kendall, P. C., Hollon, S. D., Beck, A. T., Hammen, C. L., & Ingram, R. E. (1987). Issues and recommendations regarding use of the Beck Depression Inventory. *Cognitive Therapy and Research*, 11(3), 289–299.
<https://doi.org/10.1007/BF01186280>
- Kendler, K. S., Heath, A. C., Neale, M. C., Kessler, R. C., & Eaves, L. J. (1993). Alcoholism and major depression in women: A twin study of the causes of comorbidity. *Archives of General Psychiatry*, 50, 690–698.
<https://doi.org/10.1001/archpsyc.1993.01820210024003>
- Kenneson, A., Funderburk, J. S., & Maisto, S. A. (2013). Substance use disorders increase the odds of subsequent mood disorders. *Drug and Alcohol Dependence*, 133, 338–343. <https://doi.org/10.1016/j.drugalcdep.2013.06.011>

- Kessler, R. C., Aguilar-Gaxiola, S., Alonso, J., Chatterji, S., Lee, S., Ormel, J., ... Wang, P. S. (2009). The global burden of mental disorders: An update from the WHO World Mental Health (WMH) surveys. *Epidemiologia e Psichiatria Sociale*, *18*, 23–33.
- Khantzian, E. J. (1997). The self-medication hypothesis of substance use disorders: A reconsideration and recent applications. *Harvard Review of Psychiatry*, *4*, 231–244. <https://doi.org/10.3109/10673229709030550>
- Khantzian, E. J., Halliday, K. S., & McAuliffe, W. E. (1990). *Addiction and the vulnerable self: Modified dynamic group therapy for substance abusers*. New York, NY: Guilford Press.
- Killgore, W. D. S. (1999). The Visual Analogue Mood Scale: Can a single-item scale accurately classify depressive mood state? *Psychological Reports*, *85*(3, Pt 2 [Spec Issue]), 1238–1243. <https://doi.org/10.2466/PR0.85.7.1238-1243>
- Kim, H.-Y. (2013). Statistical notes for clinical researchers: assessing normal distribution using skewness and kurtosis. *Restorative Dentistry & Endodontics*, *38*, 52–54. <https://doi.org/10.5395/rde.2013.38.1.52>
- King, A. C., Bernardy, N. C., & Hauner, K. (2003). Stressful events, personality, and mood disturbance: Gender differences in alcoholics and problem drinkers. *Addictive Behaviors*, *28*, 171–187. [https://doi.org/10.1016/S0306-4603\(01\)00264-7](https://doi.org/10.1016/S0306-4603(01)00264-7)
- Kirisci, L., Tarter, R. E., Vanyukov, M., Reynolds, M., & Habeych, M. (2004). Relation between cognitive distortions and neurobehavior disinhibition on the development of substance use during adolescence and substance use disorder by young

adulthood: A prospective study. *Drug and Alcohol Dependence*, 76, 125–133.

<https://doi.org/10.1016/j.drugalcdep.2004.04.015>

Knight, B. G., Maines, M. L., & Robinson, G. S. (2002). The effects of sad mood on memory in older adults: A test of the mood congruence effect. *Psychology and Aging*, 17, 653.

Kuntsche, E., Knibbe, R., Gmel, G., & Engels, R. (2006). Who drinks and why? A review of socio-demographic, personality, and contextual issues behind the drinking motives in young people. *Addictive Behaviors*, 31, 1844–1857.

<https://doi.org/10.1016/j.addbeh.2005.12.028>

Kuo, P.-H., Gardner, C. O., Kendler, K. S., & Prescott, C. A. (2006). The temporal relationship of the onsets of alcohol dependence and major depression: Using a genetically informative study design. *Psychological Medicine*, 36, 1153–1162.

Lee, S. B., Chung, S., Lee, H., & Seo, J. S. (2018). The mutual relationship between men's drinking and depression: A 4-year longitudinal analysis. *Alcohol and Alcoholism*, 53(5), 597–602. <https://doi.org/10.1093/alcalc/agy003>

Leeies, M., Pagura, J., Sareen, J., & Bolton, J. M. (2010). The use of alcohol and drugs to self-medicate symptoms of posttraumatic stress disorder. *Depress Anxiety*, 27.

Lembke, A. (2012). Time to abandon the self-medication hypothesis in patients with psychiatric disorders. *The American Journal of Drug and Alcohol Abuse*, 38, 524–529. <https://doi.org/10.3109/00952990.2012.694532>

Li, C.-H. (2016). Confirmatory factor analysis with ordinal data: Comparing robust maximum likelihood and diagonally weighted least squares. *Behavior Research Methods*, 48(3), 936–949.

- Liu, R. T., & Alloy, L. B. (2010). Stress generation in depression: A systematic review of the empirical literature and recommendations for future study. *Clinical Psychology Review, 30*, 582–593. <https://doi.org/10.1016/j.cpr.2010.04.010>
- Lopez, C. M., Driscoll, K. A., & Kistner, J. A. (2009). Sex differences and response styles: Subtypes of rumination and associations with depressive symptoms. *Journal of Clinical Child & Adolescent Psychology, 38*, 27–35.
- Lukassen, J., & Beaudet, M. P. (2005). Alcohol dependence and depression among heavy drinkers in Canada. *Social Science & Medicine, 61*, 1658–1667. <https://doi.org/10.1016/j.socscimed.2005.03.019>
- Lyons, M. J., Schultz, M., Neale, M., Brady, K., Eisen, S., Toomey, R., ... Tsuang, M. (2006). Specificity of familial vulnerability for alcoholism versus major depression in men. *The Journal of Nervous and Mental Disease, 194*, 809–817.
- MacKinnon, D. P., Krull, J. L., & Lockwood, C. M. (2000). Equivalence of the mediation, confounding and suppression effect. *Prevention Science, (4)*, 173–181.
- Martin, M. (1990). On the induction of mood. *Clinical Psychology Review, 10*, 669–697.
- McCarthy, D. J., Alexander, R., Smith, M. A., Pathak, S., Kaner, S., Lee, C.-M., & Sanacora, G. (2012). Glutamate-based depression GBD. *Medical Hypotheses, 78*, 675–681. <https://doi.org/10.1016/j.mehy.2012.02.009>
- McHugh, R. K., Hofmann, S. G., Asnaani, A., Sawyer, A. T., & Otto, M. W. (2010). The serotonin transporter gene and risk for alcohol dependence: A meta-analytic review. *Drug and Alcohol Dependence, 108*(2), 1–6. <https://doi.org/10.1016/j.drugalcdep.2009.11.017>

- McHugh, R. K., Votaw, V. R., Sugarman, D. E., & Greenfield, S. F. (2018). Sex and gender differences in substance use disorders. *Gender and Mental Health, 66*, 12–23. <https://doi.org/10.1016/j.cpr.2017.10.012>
- McKernan, L. C., Nash, M. R., Gottdiener, W. H., Anderson, S. E., Lambert, W. E., & Carr, E. R. (2015). Further evidence of self-medication: Personality factors influencing drug choice in substance use disorders. *Psychodynamic Psychiatry, 43*, 243–275. <https://doi.org/10.1521/pdps.2015.43.2.243>
- Milfont, T. L. (2010). Testing measurement invariance across groups: Applications in cross-cultural research. *International Journal of Psychological Research, 3*(1). <https://doi.org/10.21500/20112084.857>
- Moos, R. H., & Moos, B. S. (2006). Rates and predictors of relapse after natural and treated remission from alcohol use disorders. *Addiction, 101*, 212–222. <https://doi.org/10.1111/j.1360-0443.2006.01310.x>
- Najavits, L. M., Gotthardt, S., Weiss, R. D., & Epstein, M. (2004). Cognitive distortions in the dual diagnosis of PTSD and substance use disorder. *Cognitive Therapy and Research, 28*, 159–172. <https://doi.org/10.1023/B:COTR.0000021537.18501.66>
- Nolen-Hoeksema, S. (1990). *Sex differences in depression*. Stanford, CA: Stanford University Press.
- Nolen-Hoeksema, S. (1991). Responses to depression and their effects on the duration of depressive episodes. *Journal of Abnormal Psychology, 100*, 569.
- Nolen-Hoeksema, S. (2000). The role of rumination in depressive disorders and mixed anxiety/depressive symptoms. *Journal of Abnormal Psychology, 109*, 504–511. <https://doi.org/10.1037/0021-843X.109.3.504>

- Nolen-Hoeksema, S., & Harrell, Z. A. (2002). Rumination, depression, and alcohol use: Tests of gender differences. *Journal of Cognitive Psychotherapy, 16*, 391–403.
- Nolen-Hoeksema, S., & Hilt, L. (2006). Possible contributors to the gender differences in alcohol use and problems. *The Journal of General Psychology, 133*, 357–374.
- Nolen-Hoeksema, S., & Morrow, J. (1991). A prospective study of depression and posttraumatic stress symptoms after a natural disaster: The 1989 Loma Prieta Earthquake. *Journal of Personality and Social Psychology, 61*, 115.
- Nyenhuis, D. L., Yamamoto, C., Stern, R. A., Luchetta, T., & Arruda, J. E. (1997). Standardization and validation of the visual analog mood scales. *The Clinical Neuropsychologist, 11*, 407–415.
- Ory, D. T., & Mokhtarian, P. L. (2009). Modeling the structural relationships among short-distance travel amounts, perceptions, affections, and desires. *Transportation Research Part A: Policy and Practice, 43*, 26–43.
- Ory, D. T., & Mokhtarian, P. L. (2010). The impact of non-normality, sample size and estimation technique on goodness-of-fit measures in structural equation modeling: Evidence from ten empirical models of travel behavior. *Quality & Quantity, 44*, 427–445. <https://doi.org/10.1007/s11135-008-9215-6>
- Otto, M. W. (2007). Dysfunctional attitudes and episodes of major depression: Predictive validity and temporal stability in never-depressed, depressed, and recovered women. *Journal of Abnormal Psychology, 116*, 475–483. <https://doi.org/10.1037/0021-843X.116.3.475>
- Pantzar, A., Laukka, E. J., Atti, A. R., Fastbom, J., Fratiglioni, L., & Bäckman, L. (2014). Cognitive deficits in unipolar old-age depression: A population-based study.

Psychological Medicine, 44, 937–947.

<https://doi.org/10.1017/S0033291713001736>

Paradiso, S., Lamberty, G. J., Garvey, M. J., & Robinson, R. G. (1997). Cognitive impairment in the euthymic phase of chronic unipolar depression. *The Journal of Nervous and Mental Disease*, 185, 748–754.

Partridge, G. E. (1900). Studies in the psychology of alcohol. *The American Journal of Psychology*, 11, 318–376.

Patten, S. B. (2006). A major depression prognosis calculator based on episode duration. *Clinical Practice and Epidemiology in Mental Health*, 2(13), (online).

<https://doi.org/10.1186/1745-0179-2-13>

Pearson, C., Janz, T., & Ali, J. (2013). Mental and substance use disorders in Canada. *Health at a Glance*.

Pittenger, C., Sanacora, G., & Krystal, J. H. (2007). The NMDA receptor as a therapeutic target in major depressive disorder. *CNS & Neurological Disorders-Drug Targets (Formerly Current Drug Targets-CNS & Neurological Disorders)*, 6, 101–115.

Power, M. J., Katz, R., McGuffin, P., Duggan, C. F., Lam, D., & Beck, A. T. (1994). The Dysfunctional Attitude Scale (DAS): A Comparison of Forms A and B and Proposals for a New Subscaled Version. *Journal of Research in Personality*, 28(3), 263–276. <https://doi.org/10.1006/jrpe.1994.1019>

Preacher, K. J., & Hayes, A. F. (2008). Asymptotic and resampling strategies for assessing and comparing indirect effects in multiple mediator models. *Behavior Research Methods*, 40, 879–891. <https://doi.org/10.3758/BRM.40.3.879>

- Prescott, C. A., Aggen, S. H., & Kendler, K. S. (2000). Sex-specific genetic influences on the comorbidity of alcoholism and major depression in a population-based sample of US twins. *Archives of General Psychiatry*, *57*, 803–811.
- Preuss, U. W., & Wong, W. M. (2000). Comorbidity. In G. Zernig, M. Saria, & S. S. O'Malley (Eds.), *Handbook of alcoholism* (pp. 287–303). Boca Raton, FL: CRC Press.
- Prieto, S. L., Cole, D. A., & Tageson, C. W. (1992). Depressive self-schemas in clinic and nonclinic children. *Cognitive Therapy and Research*, *16*, 521–534.
- Ramsey, S. E., Brown, R. A., Stuart, G. L., Burgess, E. S., & Miller, I. W. (2002). Cognitive variables in alcohol dependent patients with elevated depressive symptoms: Changes and predictive utility as a function of treatment modality. *Substance Abuse*, *23*, 171–182.
- Read, J. P., Wood, M. D., Kahler, C. W., Maddock, J. E., & Palfai, T. P. (2003). Examining the role of drinking motives in college student alcohol use and problems. *Psychology of Addictive Behaviors*, *17*, 13–23.
<https://doi.org/10.1037/0893-164X.17.1.13>
- Regier, D. A., Farmer, M. E., Rae, D. S., Locke, B. Z., Keith, S. J., Judd, L. L., & Goodwin, F. K. (1990). Comorbidity of mental disorders with alcohol and other drug abuse: Results from the Epidemiologic Catchment Area (ECA) study. *JAMA Psychiatry*, *264*, 2511–2518.
- Riper, H., Andersson, G., Hunter, S. B., Wit, J., Berking, M., & Cuijpers, P. (2014). Treatment of comorbid alcohol use disorders and depression with cognitive-

- behavioural therapy and motivational interviewing: a meta-analysis. *Addiction*, *109*(3), 394–406. <https://doi.org/10.1111/add.12441>
- Risch, N., Herrell, R., Lehner, T., Liang, K.-Y., Eaves, L., Hoh, J., ... Merikangas, K. R. (2009). Interaction between the serotonin transporter gene (5-HTTLPR), stressful life events, and risk of depression: a meta-analysis. *Jama*, *301*, 2462–2471.
- Ritchie, S. J., Bates, T. C., Corley, J., McNeill, G., Davies, G., Liewald, D. C., ... Deary, I. J. (2014). Alcohol consumption and lifetime change in cognitive ability: A gene × environment interaction study. *AGE*, *36*, 1493–1502. <https://doi.org/10.1007/s11357-014-9638-z>
- Roelofs, J., Rood, L., Meesters, C., te Dorsthorst, V., Bögels, S., Alloy, L. B., & Nolen-Hoeksema, S. (2009). The influence of rumination and distraction on depressed and anxious mood: A prospective examination of the response styles theory in children and adolescents. *European Child & Adolescent Psychiatry*, *18*, 635–642. <https://doi.org/10.1007/s00787-009-0026-7>
- Rogers, T. B., Kuiper, N. A., & Kirker, W. S. (1977). Self-reference and the encoding of personal information. *Journal of Personality and Social Psychology*, *35*, 677–688. <https://doi.org/10.1037//0022-3514.35.9.677>
- Rominger, A., Cumming, P., Brendel, M., Xiong, G., Zach, C., Karch, S., ... Pogarell, O. (2015). Altered serotonin and dopamine transporter availabilities in brain of depressed patients upon treatment with escitalopram: A [¹²³I]β-CIT SPECT study. *European Neuropsychopharmacology*, *25*, 873–881. <https://doi.org/10.1016/j.euroneuro.2014.12.010>

- Rush, A. J., Weissenburger, J., & Eaves, G. (1986). Do thinking patterns predict depressive symptoms? *Cognitive Therapy and Research*, *10*, 225–235.
<https://doi.org/10.1007/BF01173727>
- Saunders, J. B., Aasland, O. G., Babor, T. F., Fuente, J. R., & Grant, M. (1993). Development of the Alcohol Use Disorders Identification Test (AUDIT): WHO collaborative project on early detection of persons with harmful alcohol consumption--II. *Addiction*, *88*. <https://doi.org/10.1111/j.1360-0443.1993.tb02093.x>
- Schleider, J. L., Ye, F., Wang, F., Hipwell, A. E., Chung, T., & Sartor, C. E. (2019). Longitudinal reciprocal associations between anxiety, depression, and alcohol use in adolescent girls. *Alcoholism: Clinical and Experimental Research*, *43*(1), 98–107.
- Schuckit, M. A., Tipp, J. E., Bucholtz, K. K., Nurnberger Jr., J. I., Hasselbrock, V. M., Crowe, R., & Kramer, J. (1997). The life-time rates of three major mood disorders and four major anxiety disorders in alcoholics and controls. *Addiction*, *92*, 1289–1304. <https://doi.org/10.1111/j.1360-0443.1997.tb02848.x>
- Schweizer, T. A., & Vogel-Sprott, M. (2008). Alcohol-impaired speed and accuracy of cognitive functions: A review of acute tolerance and recovery of cognitive performance. *Experimental and Clinical Psychopharmacology*, *16*, 240–250.
<https://doi.org/10.1037/1064-1297.16.3.240>
- Scott, J. C., Matt, G. E., Wrocklage, K. M., Crnich, C., Jordan, J., Southwick, S. M., ... Schweinsburg, B. C. (2015). A quantitative meta-analysis of neurocognitive functioning in posttraumatic stress disorder. *Psychological Bulletin*, *141*, 105.

- Segal, Z. V., Gemar, M., & Williams, S. (1999). Differential cognitive response to a mood challenge following successful cognitive therapy or pharmacotherapy for unipolar depression. *Journal of Abnormal Psychology, 108*, 3–10.
<https://doi.org/10.1037/0021-843X.108.1.3>
- Shoal, G. D., & Giancola, P. R. (2001). Cognition, negative affectivity and substance use in adolescent boys with and without a family history of a substance use disorder. *Journal of Studies on Alcohol, 62*, 675–686.
- Shrout, P. E., & Bolger, N. (2002). Mediation in experimental and nonexperimental studies: New procedures and recommendations. *Psychological Methods, 7*(4), 422.
- Skaff, M. M., Finney, J. W., & Moos, R. H. (1999). Gender Differences in Problem Drinking and Depression: Different “Vulnerabilities?” *American Journal of Community Psychology, 27*(1), 25–54. <https://doi.org/10.1023/A:1022813727823>
- Slutske, W. S. (2005). Alcohol Use Disorders Among US College Students and Their Non-College-Attending Peers. *Archives of General Psychiatry, 62*(3), 321–327.
<https://doi.org/10.1001/archpsyc.62.3.321>
- Soper, D. S. (2018). *Significance of the difference between two correlations calculator*. Retrieved from <http://www.danielsoper.com/statcalc>
- Stephens, R. S., & Curtin, L. (1995). Alcohol and depression: Effects on mood and biased processing of self-relevant information. *Psychology of Addictive Behaviors, 9*, 211–222. <https://doi.org/10.1037/0893-164X.9.4.211>

- Stern, R., Arruda, J., Hooper, C., Wolfner, G., & Morey, C. (1997). Visual analogue mood scales to measure internal mood state in neurologically impaired patients: Description and initial validity evidence. *Aphasiology, 11*, 59–71.
- Sternberg, D. E., & Jarvik, M. E. (1976). Memory functions in depression: Improvement with antidepressant medication. *Archives of General Psychiatry, 33*, 219–224.
- Sullivan, L. E., Fiellin, D. A., & O'Connor, P. G. (2005). The prevalence and impact of alcohol problems in major depression: A systematic review. *The American Journal of Medicine, 118*(4), 330–341. Retrieved from Research Library. (232333419)
- Swendsen, J. D., & Merikangas, K. R. (2000). The comorbidity of depression and substance use disorders. *Clinical Psychology Review, 20*, 173–189.
[https://doi.org/10.1016/S0272-7358\(99\)00026-4](https://doi.org/10.1016/S0272-7358(99)00026-4)
- Tabachnick, B. G., & Fidell, L. S. (2007). *Using multivariate statistics* (5th ed.). New York: Allyn and Bacon.
- Tamres, L. K., Janicki, D., & Helgeson, V. S. (2002). Sex differences in coping behavior: A meta-analytic review and an examination of relative coping. *Personality and Social Psychology Review, 6*(1), 2–30.
https://doi.org/10.1207/S15327957PSPR0601_1
- Tartter, M. A., & Ray, L. A. (2011). The serotonin transporter polymorphism (5-HTTLPR) and alcohol problems in heavy drinkers: Moderation by depressive symptoms. *Frontiers in Psychiatry, 2*, 49.
<https://doi.org/10.3389/fpsy.2011.00049>

- Thayer, J. F., Hall, M., Sollers III, J. J., & Fischer, J. E. (2006). Alcohol use, urinary cortisol, and heart rate variability in apparently healthy men: Evidence for impaired inhibitory control of the HPA axis in heavy drinkers. *Cortisol and the Addictions*, *59*, 244–250. <https://doi.org/10.1016/j.ijpsycho.2005.10.013>
- The Association of Universities and Colleges of Canada. (2011). *Trends in higher education* (No. Volume 1; pp. 1–70). Ottawa, ON: Association of Universities and Colleges of Canada.
- Tolkien, J. R. R. (1954). *The fellowship of the ring*. New York, NY: Houghton Mifflin.
- Tomlinson, K. L., Tate, S. R., Anderson, K. G., McCarthy, D. M., & Brown, S. A. (2006). An examination of self-medication and rebound effects: Psychiatric symptomatology before and after alcohol or drug relapse. *Addictive Behaviors*, *31*, 461–474.
- Tomlinson, M. F., Brown, M., & Hoaken, P. N. S. (2016). Recreational drug use and human aggressive behavior: A comprehensive review since 2003. *Aggression and Violent Behavior*, *27*, 9–29.
- Townshend, J. M., & Duka, T. (2005). Binge drinking, cognitive performance and mood in a population of young social drinkers. *Alcoholism: Clinical and Experimental Research*, *29*, 317–325. <https://doi.org/10.1097/01.ALC.0000156453.05028.F5>
- Tremblay, P. F., Graham, K., Wells, S., Harris, R., Pulford, R., & Roberts, S. E. (2010). When do first-year college students drink most during the academic year? An internet-based study of daily and weekly drinking. *Journal of American College Health*, *58*, 401–411. <https://doi.org/10.1080/07448480903540465>

- Tremblay, P. F., & Pulford, R. (2009). *Keeping track: A campus diary study of drinking patterns, depressive symptoms and interpersonal conflict*. Center for Addiction and Mental Health.
- Treynor, W., Gonzalez, R., & Nolen-Hoeksema, S. (2003). Rumination reconsidered: A psychometric analysis. *Cognitive Therapy and Research*, 27, 247–259.
<https://doi.org/10.1023/A:1023910315561>
- Tukey, J. (1977). *Exploratory data analysis*. Reading, MA: Addison-Wesley.
- van der Zwaluw, C. S., Engels, R. C. M. E., Vermulst, A. A., Rose, R. J., Verkes, R. J., Buitelaar, J., ... Scholte, R. H. J. (2010). A serotonin transporter polymorphism (5-HTTLPR) predicts the development of adolescent alcohol use. *Drug and Alcohol Dependence*, 112(1–2), 134–139.
<https://doi.org/10.1016/j.drugalcdep.2010.06.001>
- Velten, E. (1968). A laboratory task for induction of mood states. *Behaviour Research and Therapy*, 6, 473–482.
- Vredenburg, K., Flett, G., & Krames, L. (1993). Analogue versus clinical depression: A critical reappraisal. *Psychological Bulletin*, 113, 327–344.
<https://doi.org/10.1037/0033-2909.113.2.327>
- Wagner, S., Müller, C., Helmreich, I., Huss, M., & Tadić, A. (2015). A meta-analysis of cognitive functions in children and adolescents with major depressive disorder. *European Child & Adolescent Psychiatry*, 24, 5–19.
- Wang, C. E. A., Halvorsen, M., Eisemann, M., & Waterloo, K. (2010). Stability of dysfunctional attitudes and early maladaptive schemas: A 9-year follow-up study

- of clinically depressed subjects. *Journal of Behavior Therapy and Experimental Psychiatry*, *41*, 389–396. <https://doi.org/10.1016/j.jbtep.2010.04.002>
- Wang, J. C., Hinrichs, A. L., Stock, H., Budde, J., Allen, R., Bertelsen, S., ... Bierut, L. J. (2004). Evidence of common and specific genetic effects: Association of the muscarinic acetylcholine receptor M2 (CHRM2) gene with alcohol dependence and major depressive syndrome. *Human Molecular Genetics*, *13*, 1903–1911. <https://doi.org/10.1093/hmg/ddh194>
- Wang, J., & Patten, S. B. (2001). A prospective study of sex-specific effects of major depression on alcohol consumption. *The Canadian Journal of Psychiatry / La Revue Canadienne de Psychiatrie*, *46*(5), 422–425. Retrieved from PsycINFO. (620101128; 2003-05531-007)
- Wang, J., & Patten, S. B. (2002). Prospective study of frequent heavy alcohol use and the risk of major depression in the Canadian general population. *Depression and Anxiety*, *15*, 42–45.
- Weiss, R. D., Griffin, M. L., & Mirin, S. M. (1992). Drug abuse as self-medication for depression: An empirical study. *The American Journal of Drug and Alcohol Abuse*, *18*, 121–129.
- White, H. R., & Labouvie, E. W. (1989). Towards the assessment of adolescent problem drinking. *Journal of Studies on Alcohol*, *50*, 30–37.
- Willem, L., Bijttebier, P., Claes, L., Vanhalst, J., & Raes, F. (2014). The cross-temporal associations between rumination subtypes and substance use in adolescence: Exploring the moderating role of gender. *Journal of Psychopathology and Behavioral Assessment*, *36*, 143–154.

- Willner, P. (1983). Dopamine and depression: A review of recent evidence. I. Empirical studies. *Brain Research Reviews*, *6*, 211–224. [https://doi.org/10.1016/0165-0173\(83\)90005-X](https://doi.org/10.1016/0165-0173(83)90005-X)
- Wolf, E. J., Harrington, K. M., Clark, S. L., & Miller, M. W. (2013). Sample size requirements for structural equation models: An evaluation of power, bias, and solution propriety. *Educational and Psychological Measurement*, *76*, 913–934. <https://doi.org/10.1177/0013164413495237>
- Yuan, K.-H., & Bentler, P. M. (2008). Three likelihood-based methods for mean and covariance structure analysis with nonnormal missing data. *Sociological Methodology*, *30*, 165–200. <https://doi.org/10.1111/0081-1750.00078>
- Zuroff, D. C., Blatt, S. J., Sanislow III, C. A., Bondi, C. M., & Pilkonis, P. A. (1999). Vulnerability to depression: Reexamining state dependence and relative stability. *Journal of Abnormal Psychology*, *108*, 76–89. <https://doi.org/10.1037/0021-843X.108.1.76>
- Zuroff, D. C., Igreja, I., & Mongrain, M. (1990). Dysfunctional attitudes, dependency, and self-criticism as predictors of depressive mood states: A 12-month longitudinal study. *Cognitive Therapy and Research*, *14*, 315–326. <https://doi.org/10.1007/BF01183999>

Appendices

Appendix A: Letters of Information and Consent and Debriefing Forms



Letter of Information and Consent for Community Study

Project Title: Thinking, Drinking, and Mood Study

Document Title: Letter for Participants in the MTurk Study

Principal Investigator: David Dozois, PhD, CPsych.

Additional Research Staff: Monica Tomlinson, MSc.

1. Introduction

We are inviting you to participate in a study on how people's drinking behaviors impact thoughts and feelings.

2. Invitation to Participate

We are inviting you to participate in Phase I, II, III, IV and V of this research study. Phase I will begin today. Phase II will be in 3 months. Phase III will be in 6 months, Phase IV will be in 9 months, and Phase V will be in 1 year. Each phase will take between 15-30 minutes of your time (maximum 2.5 hours in total, over the course of one year)

If you participate in this study, you will be completing several questionnaires pertaining to your drinking behavior (if you drink alcohol), your thoughts, and your feelings. You may also be selected to go through a short activity that will present you with several words on a screen while you are listening to music. You may also be selected to go through a short activity that will ask you to think of happy thoughts.

3. Why is This Study Being Done?

Alcohol is the most widely consumed drug worldwide. Alcohol use is known to alter people's information processing, which can change the way they feel about themselves, others, and the world around them. We are interested in better understanding how different drinking behaviors might influence people's thoughts and feelings. For example, we are interested in whether different drinking behaviors lead people to have happier or sadder thoughts, and whether those thoughts influence their psychological functioning.

4. How Long Will You be in This Study?

We would like you to be in our study for one year. We will contact you in 3 months, 6 months, and 12 months to see whether you would like to complete a short questionnaire

(15-30 minutes) at each of those time points.

5. What Are the Study Procedures?

If you agree to participate, you will be asked to complete a series of questionnaires on The University of Western Ontario's Server. The University of Western Ontario's Server is a secure online survey portal. You will be asked about your drinking habits, your mood, and some thoughts that you might have. You may also be selected to participate in activities that require you to listen to music, read sentences on a screen, or write about a happy experience.

6. What are the Risk and Harms of Participating in This Study?

You may experience mild discomfort when completing some of our questionnaires. If you experience any distress during the study, we encourage you to contact the PI or Monica Tomlinson. If you are experiencing any problems with your drinking or mood, we would like to help you. We both have training in psychology and would be happy to connect you to appropriate resources.

7. What are the Benefits of Participating in the Study?

You may not directly benefit from participating in this study but the information gathered may provide benefits to society as a whole, which include a better understanding of how to help people who struggle with drinking or sad mood. You will also receive information on mental health services, which might be helpful to you.

8. Can Participants Choose to Leave the Study

If you decide to withdraw from the study, the information that was collected prior to you leaving the study will still be used, unless you indicate to us that you would not like for it to be used (i.e., by emailing us). No new information will be collected without your permission. You can choose to leave the study at any time. However, you will only receive credit if you complete the study. **At the completion of the study, you will be provided with a unique code. You need to enter this code at the end of the survey to receive credit by MTurk.**

9. How Will Participants' Information Be Kept Confidential?

When you consent to participate in this study, MTurk will generate a random Participant ID code (in accordance with the researcher's guidelines). You will need this code to complete the other phases of this study. MTurk will also automatically provide your Worker ID Code to the researchers. You will not give us any identifying information in this study. Therefore, none of the responses that you provide us can be linked back to you.

All data will be saved on the University of Western Ontario's Server and only Dr. David Dozois and Monica Tomlinson will have any access to that data. The University of Western Ontario's server is secure. We will store this data for five years and then delete it from the University of Western Ontario's server.

While we do our best to protect your information there is no guarantee that we will be able to do so. If we are required by law to report any data collected, we have a duty to report.

10. Are Participants Compensated to Be in This Study?

You will be compensated \$1.50 if you participate in Phase I of this study and \$2.00 if you participate in Phases II-V. If you participate in all five phases, you will receive a total of \$9.50.

11. What Are the Rights of Participants?

Your participation in this study is voluntary. You may decide not to be in this study. Even if you consent to participate you have the right to not answer individual questions or to withdraw from the study at any time. If you choose not to participate or to leave the study before completion, however, you will not be compensated. **MTurk provides you with a code at the end of your questionnaire. You will need this code to be compensated.**

Consent

Project Title: Thinking, Drinking, and Mood Study

Document Title: Letter for Participants in the MTurk Study

Principal Investigator: David Dozois, PhD, CPsych.

Additional Research Staff: Monica Tomlinson, MSc.

Do you confirm that you have read the Letter of Information [or the Letter of Information has been read to you] and have had all questions answered to your satisfaction?

YES NO

Do you agree to participate in this research?

YES NO

Do you agree to be contacted for future phases of this study? That is, in 3 months, 6 months, 9 months, and 12 months?

YES NO

Letter of Information and Consent for Student Study



Letter of Information and Consent

Please read this information carefully before you continue.

Project Title: Thinking, Drinking, and Mood Study

Principal Investigator: David Dozois, PhD, CPsych.

Additional Research Staff: Monica Tomlinson, MSc

1. Introduction

We are inviting you to participate in a study on how people's drinking behaviors impact thoughts and feelings.

2. Invitation to Participate

We are inviting you to participate in Phase I and II of this research study. Phase I will begin today. Phase II will begin in three months. Each phase will take between 45-60 minutes of your time (maximum two hours in total).

If you participate in this study, you will be completing several questionnaires pertaining to your drinking behavior (if you drink alcohol), your thoughts, and your feelings. You may also be selected to go through a short activity that will present you with several words on a screen while you are listening to music. You may also be selected to go through a short activity that will ask you to think of happy thoughts.

3. Why is This Study Being Done?

Alcohol is the most widely consumed drug worldwide. Alcohol use is known to alter people's information processing, which can change the way they feel about themselves, others, and the world around them. We are interested in better understanding how different drinking behaviors might influence people's thoughts and feelings. For example, we are interested in whether different drinking behaviors lead people to have happier or sadder thoughts, and whether those thoughts influence their psychological functioning.

4. How Long Will You be in This Study?

We would like you to be in our study for 3 months. We will contact you in 3 months to see whether you would like to complete the second phase of this study.

5. What Are the Study Procedures?

If you agree to participate, you will be asked to complete a series of questionnaires on The University of Western Ontario's Server. The University of Western Ontario's Server is a secure online survey portal. You will be asked about your drinking habits, your mood, and some thoughts that you might have. You may also be selected to participate in activities that require you to listen to music, read sentences on a screen, or write about a happy experience.

6. What are the Risks and Harms of Participating in this Study?

You may experience mild discomfort when completing some of our questionnaires. If you experience any distress during the study, we encourage you to contact the PI or Monica Tomlinson. If you feel you cannot complete the study, please end the study and contact Dr. Dozois or Monica Tomlinson. If you are experiencing any problems with your drinking or mood, we would like to help you. Please contact either Dr. Dozois or Monica Tomlinson. We both have training in psychology. You can also alert a researcher to your discomfort.

7. What are the Benefits of Participating in the Study

You may not directly benefit from participating in this study but the information gathered may provide benefits to society as a whole, which include a better understanding of how to help people who struggle with drinking or sad mood. You will also receive information on mental health services, which might be helpful to you.

8. Can Participants Choose to Leave the Study?

If you decide to withdraw from the study, the information that was collected prior to you leaving the study will still be used, unless you indicate to us that you would not like it to be used (i.e., by alerting a researcher or emailing us). No new information will be collected without your permission.

9. How Will Participants' Information Be Kept Confidential?

When you consent to participate in this study, you will use your SONA ID code as your participant ID code. You will input this ID code on both lab visits so that we can connect your data. You will not give us any identifying information in this study. We will ask you for your email address at the beginning of the first visit to contact you for the second lab visit, in three months. This email address will be kept in a separate file and will not be linked to your SONA ID code or any data.

All data will be saved on the University of Western Ontario's Server and only Dr. David Dozois and Monica Tomlinson will have any access to that data. The University of Western Ontario's server is secure. We will store this data for five years and then delete it from the University of Western Ontario's server.

While we do our best to protect your information there is no guarantee that we will be able to do so. If we are required by law to report any data collected, we will report it.

10. Are Participants Compensated to Be in This Study?

If you are in Psychology 1000, you will be compensated with course credit. You will receive 0.5 credits for each 1/2 hour of your time. If you are not in Psychology 1000, you will receive course credit based on information provided in your course outline. If you have any questions about the compensation, please refer to your course outline or contact your course instructor.

11. What Are the Rights of Participants?

Your participation in this study is voluntary. You may decide not to be in this study. Even if you consent to participate you have the right to not answer individual questions or to withdraw from the study at any time. If you choose not to participate or to leave the study at any time it will have no effect on your compensation.

Do you confirm that you have read the Letter of Information and have had all questions answered to your satisfaction?

YES NO

Do you confirm that you are fluent in English, are in a class that awards course credit in exchange for research participation, are over the age of 17, and have normal or corrected-to-normal hearing and vision?

YES NO

Do you agree to participate in this research?

YES NO

Do you agree to be contacted for future phase 2 of this study? That is, in 3 months?

YES NO



DEBRIEFING FORM

Community Study

Project Title: Drinking, Thinking, and Mood Study

Principal Investigator: Dr. David Dozois

Main Researcher: Monica Tomlinson, MSc.

Thank you for your participation in this study. We REALLY appreciate your contributions to this research. The purpose of this study was to know more about the relationship between drinking, thinking, and mood. Sometimes people have more negatively-biased thinking patterns. We wanted to know whether people who drink more alcohol have more negative thoughts. We were also interested in whether people who have more negative thoughts feel more depressed than people with less negative thoughts.

We predicted that people who drank more alcohol, more often, would have more negative thoughts, and that those negative thoughts would increase their chances of feeling depressed.

If you have any questions or concerns, or if you experienced any distress during this study, we strongly recommend that you contact the PI of this study (Dr. David Dozois) or Monica Tomlinson. Both Dr. Dozois and Monica have training in psychology, and would be happy to help you.

Here are some references if you would like to read more on this topic:

Boden, J. M., & Fergusson, D. M. (2011). Alcohol and depression. *Addiction*, *106*(5), 906–914. <https://doi.org/10.1111/j.1360-0443.2010.03351.x>

Boschloo, L., Vogelzangs, N., van den Brink, W., Smit, J. H., Veltman, D. J., Beekman, A. T. F., & Penninx, B. W. J. H. (2012). Alcohol use disorders and the course of depressive and anxiety disorders. *The British Journal of Psychiatry*, *200*(6), 476–484. <https://doi.org/10.1192/bjp.bp.111.097550>

Below are a variety of resources if you are interested in learning more about depression, alcohol, how you can help yourself, or how you can arrange for professional help.

Self-Help References:

If you would like to look up some good self-help books on changing negative thinking or drinking habits, please see:

- ❖ Burns, D. D. (1980). *Feeling good*. New York: Penguin.
- ❖ Burns, D. D. (1989). *The feeling good handbook*. New York: Penguin.
- ❖ Greenberger, D., & Padesky, C. A. (2015). *Mind over mood: Change the way you feel by changing the way you think*. 2nd Edition. Guilford Press.
- ❖ Wright, J. H., & McCray, L. W. (2011). *Breaking free from depression: Pathways to wellness*. Guilford Press
- ❖ Williams, R. E., & Kraft, J. S. (2012). *The Mindfulness Workbook for Addiction: A Guide to Coping with the Grief, Stress and Anger that Trigger Addictive Behaviors*. New Harbinger Publications.

❖ Miller, W. R., & Muñoz, R. F. (2013). *Controlling your drinking: Tools to make moderation work for you*. Guilford Press.

Available Services

There are several ways in which individuals can access psychological or psychiatric help within the United States. If you are feeling depressed or anxious or feel that you could benefit from some individual assistance with drinking or other issues, the following information may be of use to you.

Immediate Help:

If you are in crisis, and need immediate support or intervention, call, or go the website of the [National Suicide Prevention Lifeline](http://suicidepreventionlifeline.org) (<http://suicidepreventionlifeline.org>) (1-800-273-8255). **Trained crisis workers are available to talk 24 hours a day, 7 days a week.** Your confidential and toll-free call goes to the nearest crisis center in the Lifeline national network. These centers provide crisis counseling and mental health referrals. If the situation is potentially life-threatening, call 911 or go to a hospital emergency room.

Telephone Helplines

U.S. Helplines

US Suicide Hotline	1-800-784-2433
NDMDA Depression Hotline – Support Group	800-826-3632
Suicide Prevention Services Crisis Hotline	800-784-2433
Suicide Prevention Services Depression Hotline	630-482-9696
AAA Crisis Pregnancy Center	800-560-0717
Child Abuse Hotline – Support & Information	800-792-5200
Crisis Help Line – For Any Kind of Crisis	800-233-4357
Domestic & Teen Dating Violence (English & Spanish)	800-992-2600
Parental Stress Hotline – Help for Parents	800-632-8188
Runaway Hotline (All Calls are Confidential)	800-231-6946
Sexual Assault Hotline (24/7, English & Spanish)	800-223-5001
Suicide & Depression Hotline – Covenant House	800-999-9999
National Child Abuse Hotline	800-422-4453
National Domestic Violence Hotline	800-799-SAFE
National Domestic Violence Hotline (TDD)	800-787-3224
National Youth Crisis Hotline	800-448-4663

(taken from: <http://psychcentral.com/lib/telephone-hotlines-and-help-lines/>)

General Information or Resources in Your Area:

For general information on mental health and to locate treatment services in your area, call the Substance Abuse and Mental Health Services Administration (SAMHSA) Treatment Referral Helpline at 1-800-662-HELP (4357). SAMHSA also has a [Behavioral Health Treatment Locator](https://findtreatment.samhsa.gov) (<https://findtreatment.samhsa.gov>) on its website that can be searched by location.

Anxiety and Depression Association of America

<https://www.adaa.org/>

Depression and Bipolar Support Alliance

<http://www.dbsalliance.org/site/PageServer?pagename=home>

Mental Health America

<http://www.mentalhealthamerica.net/finding-help>

National Alliance on Mental Health

Phone: 800-950-6264

Website: www.nami.org

American Psychological Association

Psychology Help Centre

<http://www.apa.org/helpcenter/index.aspx>



DEBRIEFING FORM Student Study

Project Title: Drinking, Thinking, and Mood Study

Principal Investigator: Dr. David Dozois

Main Researcher: Monica Tomlinson

Thank you for your participation in this study. The purpose of this study was to know more about the relationship between drinking, thinking, and mood. Sometimes people have more negatively-biased thinking patterns. We wanted to know whether people who drink more alcohol have more negative thoughts. We were also interested in whether people who have more negative thoughts feel more depressed than people with less

negative thoughts. We predicted that people who drank more alcohol, more often, would have more negative thoughts, and that those negative thoughts would increase their chances of feeling depressed.

If you have any questions or concerns, or if you experienced any distress during this study, we strongly recommend that you contact the PI of this study (Dr. David Dozois) or Monica Tomlinson. Both Dr. Dozois and Monica have training in psychology, and would be happy to help you.

Here are some references if you would like to read more on this topic:

Boden, J. M., & Fergusson, D. M. (2011). Alcohol and depression. *Addiction, 106*(5), 906–914. <https://doi.org/10.1111/j.1360-0443.2010.03351.x>

Boschloo, L., Vogelzangs, N., van den Brink, W., Smit, J. H., Veltman, D. J., Beekman, A. T. F., & Penninx, B. W. J. H. (2012). Alcohol use disorders and the course of depressive and anxiety disorders. *The British Journal of Psychiatry, 200*(6), 476–484. <https://doi.org/10.1192/bjp.bp.111.097550>

Appendix B: Data Cleaning and Analysis of Measures for Community Study

Duplicate Data Sets

Data files from all five time points were merged into one SPSS file for data cleaning. Twelve-hundred and five participants were in the final data set with all of the time points merged. Sixty-seven duplicate files emerged and were deleted, 1133 participants remained.

Attention Checks

Test items were re-coded as either 0 = fail or 1 = pass so that total number of failed attention checks could be computed. In Time 1 ($N = 1133$), 103 participants (9%) failed one attention check, 27 participants (2%) failed two attention checks, and 10 participants failed three to five attention checks (.8%). In Time 2 ($N = 751$), 20 participants (2.6%) failed one attention check, and 10 participants (1%) failed two or more. In Time 3 ($N = 391$), nine participants (2%) failed one attention check and one (.02%) failed two attention checks. At Time 4 ($N = 413$), 11 participants (2.6%) failed one attention check and two failed more than one (.04%). In Time 5 ($N = 454$), 12 participants (2.6%) failed one attention check and two participants (.04%) failed more than one. Individuals who failed more than one attention check in Time 1 were not invited back to participate in the following time points. Analyses were completed with and without participants who failed attention checks from Time points 1-5. There were no differences in the analyses that including participants who failed attention checks and those who did not. Therefore, all participants who failed attention checks were retained in the final analyses.

Outliers

Outliers were reviewed by assessing the quartiles of each scale. A widely held definition of an outlier is any data point more than 1.5 interquartile ranges (IQRs) below the first quartile or above the third quartile (Hoaglin, Iglewicz, & Tukey, 1986; Tukey, 1977). Interquartile ranges for all scales were computed and data was visually analyzed for outliers. No outliers were present on the AUDIT, RAPI, BDI-II, DAS, or VAS. This is not surprising, as the general range for these scales is relatively low. Outliers are more common in data with indefinite ranges (e.g., response time data).

Analysis of Non-Normality

Skewness and kurtosis were then analyzed for data at each time point. The kurtosis cutoff points are driven by the literature summarized in Ory & Mokhtarian (2009, 2010), which suggests that kurtosis values of one or less indicate negligible non-normality, values between 3.5 and 10 indicate moderate non-normality, and values greater than 10 indicate severe non-normality. The generally acceptable cutoff for skewness is 2 (Kim, 2013). The findings for skewness and kurtosis were similar across time points, and thus only Time 1 data are presented here (*Table 2*) to offer an example of the findings. For Time 1, the AUDIT Dependence and Harmful subscales both indicated skewness slightly above the accepted levels, as did the all of the RAPI subscales. The Dependence and Harmful subscales of the AUDIT as well as the RAPI total and Dependence/Withdrawal subscale indicated moderate non-normality. The Social/Occupational subscale of the RAPI indicated severe non-normality. A review of the distribution for this subscale indicates that the majority of scores on this measure are zero, which peaks the data at the low end of this scale (which is expected in a community sample).

Non-normal distributions are extremely common in behavioural sciences research (Kim, 2013), and several statistical methods have been developed to assuage their impact on analytic results. When sample sizes are small, these concerns of non-normality become particularly important, as results can diverge very significantly depending on the analytic approach used (Ory & Mokhtarian, 2009). For larger samples sizes ($N = 1000+$), the analytic approach used (e.g., Maximum Likelihood, Bootstrapping) is less important (Ory & Mokhtarian, 2009). Therefore, while they are not anticipated to have a notable impact on the findings of this study, they were taken into consideration and statistical methods for reducing their effects were used.

Missing Data

During each time point, the data were visually scanned to see if any participants had large proportions of missing data. Two participants were removed from the analyses, as they had more than 20% of their data missing at Time 1 and were not invited back to participate in the remaining time points. There were no participants from that point forward who had large proportions of missing data. For participants who missed specific items on questionnaires (which was a rare occurrence), data point was replaced with the mean for the other responses on that questionnaire for that person. Missing data points for variables where means could not be imputed (e.g., demographic data) were deleted from analyses using listwise deletion. The sample sizes for each time point, once data were cleaned, are as follows (Time 2: $N = 738$; Time 3: $N = 576$; Time 4: $N = 677$; Time 5: $N = 617$). Time 3 (August 2017) may have fallen at a time when several people are on vacation.

Equivalence of DAS A and DAS B

The two versions of the DAS were compared to each other using a paired-sampled t-test for each wave of data collection. Across all time points, there was a significant difference between the two versions of the DAS [Time 1, $t(348) = -11.67, p < .01$; Time 2, $t(652) = -14.28, p < .01$; Time 3, $t(520) = -10.59, p < .01$; Time 4, $t(601) = -13.91, p < .01$; Time 5, $t(547) = -11.03, p < .01$]. At each time point, the mean for DAS B was higher than DAS A (e.g., at Time 1, $M_{\text{DasA}} = 15.20, SD = 4.76$; $M_{\text{DasB}} = 17.52, SD = 3.99$). Correlations between the DAS A and DAS B at each time point were also lower than expected, ranging from $r = .65$ at Time 1 to $r = .75$ at Time 2. These findings indicate that these two version of the DAS are not equivalent. Given that the parallel versions were presented in counterbalanced order for each participant, the differences between the two form were controlled for.

Effect of the Mood Prime on Mood in the Community Study

Each participant who was in the priming condition completed a Visual Analog Scale to rate their mood from sad to happy (on a 100-point line) before the sad mood prime, after the sad mood prime, and after the happy mood prime at the end of the study. A paired-samples t-test revealed significant differences in mood from each condition to the next throughout each component of the study.

For example, at Time 1, participants ($n = 350$) rated themselves an average of 73.51 out of 100 before the mood prime ($SD = 17.49$), 51.16 out of 100 following the mood prime ($SD = 23.15$), and 76.00 out of 100 following the happy mood prime ($SD = 16.99$). All differences were significant at $p < .01$. Of note, while the sad mood prime did significantly lower mood, and the happy mood prime did significantly improve mood, the

sad mood prime did not make participants feel sad (below 50 on the VAS). Rather, the sad mood prime appears to have made participants' moods more neutral.

Effect of the Mood Prime on Dysfunctional Attitudes

To determine whether lowering mood increased participants' dysfunctional attitudes, a paired-samples t-test was conducted on DAS scores before participants went through the sad mood prime, and afterwards. Time 2 data were used for these analyses as the most people were primed in Time 2 compared to any other time point, therefore power to detect differences is highest in this phase. More people were primed during this phase because more people endorsed levels of depression in the low-moderate range in this time point compared to any other time point. Therefore, the most people were exposed to the prime at this time point compared to any other time point. That is, at other time points, more participants bypassed the prime because of their higher levels of depressive symptoms. Time 1 also had a group of participants randomly assigned to bypass the mood prime, regardless of their depression scores. Therefore, there were fewer participants exposed to the mood prime in Time 1 compared to Time 2.

Total DAS scores were calculated for individuals in the pre-prime, post-prime, and no-prime conditions. In Time 2, a significant increase in dysfunctional attitudes, $t(652) = -3.85, p < .01$, was detected from pre-prime ($n = 653, M = 16.84, SD = 4.94$) to post-prime ($n = 653, M = 17.46, SD = 5.27$). This effect was also replicated at Time 3, which has the second largest sample size. Although post-prime scores were higher than pre-prime scores at each time point, no significant difference was detected from pre-prime to post-prime at Time 1 ($n = 349, p = .89$), Time 4 ($n = 602, p = .10$), or Time 5 ($n = 548, p = .07$).

An independent samples t-test, with DAS scores as the dependent variable and condition as the grouping variable (post and no prime) was also conducted to determine whether there was a difference between people who completed the prime and people who did not (because their levels of depressive symptoms were high). This analysis will shed light on whether people with higher levels of depressive symptoms naturally have higher levels of dysfunctional attitudes (without them being primed), and whether their levels of dysfunctional attitudes are comparable to the participants who were primed. In Time 2, participants who did not complete the prime ($n = 81$, $M = 22.36$, $SD = 4.77$) had significantly higher DAS scores ($t(731) = 7.96$, $p < .01$) compared to those who completed the prime ($n = 652$, $M = 17.46$, $SD = 5.27$), suggesting that individuals with high levels of depressive symptoms have significantly more dysfunctional attitudes overall (without having a sad mood induced) compared to individuals with lower depressive symptoms after they have been primed into a lower mood. Therefore, the prime is not increasing individuals' levels of dysfunctional attitudes to the same level as individuals with moderate-high levels of depression, which we may expect.

In Time 1, a group of participants who had low levels of depressive symptoms were randomly assigned not to go through the sad mood prime. This group was created as another way to test the effectiveness of the sad mood prime. An independent groups t-test was conducted with DAS scores as the dependent variable and group (control group vs. post-prime group) as the independent variable. No significant difference was detected, [$t(699) = -.94$, $p = .35$], between the control group ($n = 352$, $M = 16.37$, $SD = 4.67$) and the post-prime group ($n = 16.69$, $M = 16.37$, $SD = 4.52$). Therefore, while there is some evidence that dysfunctional attitudes increase following the prime, this effect is not

consistent across time points, and Time 1 data does not suggest that the prime is the specific cause of these changes.

Appendix C: Confirmatory Factor Analyses of the Measures (Community Data)

RAPI

On the RAPI, a 1-factor solution accounted for 50.8% of the variance and all factor loadings were above .60. The 2-factor solution accounted for 59.0% of the variance. For this extraction, a promax rotation with Kaiser normalization was used because correlations between items in the two factors were generally low. Items 1, 2, 4, 5, 7, 11, 13, 15, 16, 17, 18, and 21 loaded highly onto the “social/occupational consequences” factor (all factor loadings above .30) and items 3, 6, 8, 9, 10, 14, 20, 22, and 23 loaded highly onto the “dependence/withdrawal” factor (all loadings above .40). Therefore, this questionnaire was considered to have two distinct underlying factors in our Time 1 sample, which is consistent with the two theoretical underlying factors of alcohol problems (Dick et al., 2011).

AUDIT

A CFA using maximum likelihood extraction was also conducted on the AUDIT. A single factor solution accounted for 56.0% of the variance. All factor loadings were above .50, suggesting that this questionnaire assesses one underlying dimension of drinking problems. Therefore, any analyses evaluating the subscales of this measure warrant a cautious interpretation of the findings.

DAS

A CFA was conducted on both short-form versions of the DAS (DAS_A and DAS_B). DAS_A revealed a one factor solution that accounted for 51.7% of the variance. When a 2-factor solution with a direct oblimin Kaiser normalization rotation was conducted, this solution accounted for 61.9% of the variance, with items 2, 3, 5, 8, and 9 loading onto

factor 1, and items 1, 4, 6, and 7 loading onto factor 2. However, most items loaded highly onto both factors. For DAS_B, a 1-factor solution accounted for 42.9% of the variance and a 2-factor solution with a direct oblimin Kaiser normalization accounted for 57.3% of the variance. Items 1, 4, 5, 7, 8, 9 all correspond to the previously identified perfectionism subscale from the long-form of the DAS and items 2, 3, 6 load highly onto the second factor and correspond with the “need for approval” subscale of the long-form of the DAS. Given that the two versions of this scale were not comparable, they could not equally be separated into their theoretical “need for approval” and “perfectionism” subscales. Therefore, the total scores on these two forms were used. Regrettably, despite how widely used this scale is, other researchers have found similar problems with its psychometric properties (Power et al., 1994).

BDI-II

On the BDI-II, a one factor solution accounted for 52.5% of the variance. The two-factor solution with a direct oblimin Kaiser normalization rotation accounted for 58.9% of the variance and the items loaded clearly onto the two pre-identified underlying dimensions; cognitive and somatic/affective symptoms. Items 1, 2, 3, 5, 6, 7, 8, 9, 13, and 14 loaded onto the cognitive factor and Items 4, 10, 11, 12, 15, 16, 17, 18, 19, 20, 21 loaded onto the somatic/affective dimension (all standardized loadings above .4 for both dimensions).

Based on the results of these CFAs, we replicated the results from previous studies suggesting that the RAPI and BDI-II each have two underlying dimensions. Our findings were consistent with the 1-factor solution of the AUDIT, and do not support separating this scale into its suggested subscales (hazardous drinking, harmful drinking,

dependence/withdrawal). Our results demonstrated that, contrary to the 2-dimension structure of the long-form of the DAS, the two short forms included in this study do not both carry that same structure, and are best represented as having one underlying dimension.

DMQ

The CFA conducted on the DMQ-R found that a one-factor solution accounted for 36% of the variance, a two-factor solution accounted for 51% of the variance, a three-factor solution accounted for 64% of the variance, and, consistent with the literature (Cooper, 1994), a four-factor solution fit the data well, accounting for 69% of the variance when a direct oblimin Kaiser normalization rotation was employed. A review of the pattern coefficients indicated that the items did not load well onto their intended factors. The four pre-determined factors: social (3, 5, 11, 14, 16), coping (1, 4, 6, 15, 17), enhancement (7, 9, 10, 13, 18), and conformity (2, 8, 12, 19, 20) did not hold up in these analyses. Rather, factor one (items 3, 5, 12, 15, 16) was a combination of social, coping, and conformity items (all loadings above .5). Factor two (items 1, 4, 6, 18) involved a combination of coping and enhancement items (all loadings above .8). Factor 3 (items 2, 7, 9, 13, 20) was comprised of a combination of conformity and enhancement (all loadings above .65). Factor 4 (8, 10, 11, 14, 19) was a combination of enhancement, conformity, social, and coping (all loadings above .56).

Appendix D: Additional Descriptive Data

Table 10. Correlations Between Variables Across Time Points.

	Time 1 February	Time 2 May	Time 3 August	Time 4 November	Time 5 January
Time 1 BDI	1	.85	.85	.79	.80
Time 2 BDI		1	.89	.86	.86
Time 3 BDI			1	.85	.87
Time 4 BDI				1	.86
Time 5 BDI					1
Time 1 AUDIT	1	.79	.84	.82	.80
Time 2 AUDIT		1	.88	.86	.85
Time 3 AUDIT			1	.89	.87
Time 4 AUDIT				1	
Time 5 AUDIT					1
Time 1 RAPI	1	.78	.73	.62	.65
Time 2 RAPI		1	.83	.76	.66
Time 3 RAPI			1	.79	.72
Time 4 RAPI				1	.85
Time 5 RAPI					1
Time 1 DAS	1	.69	.68	.75	.68
Time 2 DAS		1	.72	.76	.70
Time 3 DAS			1	.81	.71
Time 4 DAS				1	.75
Time 5 DAS					1

Note: All correlations are significant at $p < .001$.

Variability in Measures Across Time

To determine whether depressive symptomatology, alcohol problems, and dysfunctional attitudes significantly changed over time, and across sex at each time point, a mixed between/within subjects repeated-measures ANOVA was conducted with sex as the between-subjects variables (2 levels: male and female) and time as the within-subjects variables (5 levels: Time 1, Time 2, Time 3, Time 4, and Time 5) for each measures using IBM SPSS Statistics Version 25. When Mauchley's test of sphericity was significant (indicating that the variances of the differences between conditions are not

equal), and the Greenhouse-Geisser estimate of sphericity was higher than .75, the Huynh-Feldt corrected degrees of freedom were used to make the F-statistic more conservative (Field, 2013). When the Greenhouse-Geisser statistic was below .75, the Greenhouse-Geisser corrected degrees of freedom were used to make the F-statistic more conservative (Field, 2013).

Variability in Depressive Symptomatology

Over time, across men and women, depressive symptomatology remained stable, $F(3.62, 15552.4) = 2.01, p = .09$. There was also no interaction effect between time and sex, $F(3.62, 15552.43), p = .49$. Consistent with the literature on depression, there was a significant main effect of sex, such that women ($M = 10.87, SD = 11.25$) had significantly higher levels of depressive symptomatology across time, $F(1, 428) = 5.28, p = .02$ than men ($M = 8.38, SD = 11.25$).

Variability in Alcohol Use and Problems

On the AUDIT, a main effect of time, $F(3.62, 1020.74) = 4.97, p < .01$, partial $\eta^2 = .02$ was revealed, such that Time 1 ($M = 6.18, SD = 5.39$) alcohol use disorder symptomatology was significantly higher than Time 2 ($M = 5.65, SD = 5.19, p = .05$), Time 4 ($M = 5.57, SD = 5.47, p = .02$) and Time 5 ($M = 5.52, SD = 5.21, p < .01$). No significant interaction between time and sex was found. Also consistent with the literature, a significant main effect of sex was found on alcohol use disorder symptomatology, $F(1, 282) = 12.23, p < .01$, however this effect was in the opposite direction of depressive symptomatology. Consistent with the literature, men ($M = 6.67, SD = 4.94$) had higher levels of alcohol problems compared to women ($M = 4.61, SD = 4.93$).

On the RAPI, a main effect of time, $F(2.99, 840.16) = 4.43, p = .04$, partial $\eta^2 = .02$ was revealed, such that Time 1 ($M = 3.62, SD = 6.92$) alcohol problems were significantly higher than Time 4 ($M = 2.63, SD = 5.63, p = .03$) alcohol problems. No interaction effect of time and sex was found. No significant effect of sex was revealed either. While men have higher levels of alcohol use disorder symptomatology (based on the AUDIT), there were no sex differences in the number of problems caused by excessive alcohol use on the RAPI. Therefore, women may experience more problems related to alcohol use, even if they do not display higher levels of AUD symptomatology. It is important to note that the RAPI scale total scores range from 0 to 69. On this measure, there was likely a floor effect, as means for both groups were below 7 for both sexes, across time.

Variability in Dysfunctional Attitudes

On the post-prime DAS scores, a main effect of time, $F(4, 540) = 4.77, p < .01$, partial $\eta^2 = .03$ was revealed, such that Time 2 ($M = 16.67, SD = 5.22$) dysfunctional attitudes were significantly higher than Time 4 ($M = 15.30, SD = 5.00, p < .01$) and Time 3 dysfunctional attitudes ($M = 16.59, SD = 4.73, p < .01$) were significantly higher than Time 4 ($M = 15.30, SD = 5.00, p < .01$). Time 4 dysfunctional attitudes were significantly lower than Time 5 ($M = 16.41, SD = 5.27, p = .04$). Therefore, dysfunctional attitudes decreased from Time 2 to Time 4 and from Time 3 to Time 4, and then increased from Time 4 to Time 5. No significant interaction between time and sex was found, and no main effect of sex was found. Although men and women significantly differ in their levels of alcohol use disorder symptoms (AUDIT) and depressive symptoms, they do not differ in their levels of dysfunctional attitudes.

Table 11. AUDIT, RAPI, DAS, and BDI-II Scores Across One Year, By Sex (Community Study).

Measure	Time 1 (<i>M, SD</i>) February 2017	Time 2 (<i>M, SD</i>) May 2017	Time 3 (<i>M, SD</i>) August 2017	Time 4 (<i>M, SD</i>) November 2017	Time 5 (<i>M, SD</i>) February 2018
AUDIT	<i>n</i> = 903 7.03 , 6.90	<i>n</i> = 602 6.11 , 5.97	<i>n</i> = 440 6.14 , 6.03	<i>n</i> = 536 6.04 , 6.32	<i>n</i> = 484 5.77 , 5.91
Men	<i>n</i> = 504 8.23 , 7.43	<i>n</i> = 321 7.22 , 6.45	<i>n</i> = 231 7.00 , 6.50	<i>n</i> = 297 7.19 , 6.99	<i>n</i> = 268 6.78 , 6.44
Women	<i>n</i> = 339 5.52 , 5.70	<i>n</i> = 281 4.82 , 5.06	<i>n</i> = 209 5.19 , 5.32	<i>n</i> = 239 4.61 , 5.02	<i>n</i> = 216 4.53 , 4.89
RAPI	<i>n</i> = 902 5.30 , 9.43	<i>n</i> = 602 3.92 , 7.86	<i>n</i> = 440 3.77 , 7.57	<i>n</i> = 535 3.74 , 7.63	<i>n</i> = 484 3.37 , 7.14
Men	<i>n</i> = 503 6.25 , 9.43	<i>n</i> = 321 4.61 , 8.58	<i>n</i> = 231 4.11 , 8.15	<i>n</i> = 297 4.51 , 8.50	<i>n</i> = 268 4.19 , 8.25
Women	<i>n</i> = 399 4.09 , 8.21	<i>n</i> = 281 3.13 , 6.86	<i>n</i> = 209 3.40 , 6.87	<i>n</i> = 238 2.78 , 6.27	<i>n</i> = 216 2.35 , 5.28
DAS	<i>n</i> = 701 16.53 , 4.59	<i>n</i> = 734 18.00 , 5.43	<i>n</i> = 573 17.68 , 5.46	<i>n</i> = 328 17.18 , 5.76	<i>n</i> = 612 17.82 , 5.51
Men	<i>n</i> = 400 16.75 , 4.58	<i>n</i> = 384 18.08 , 5.23	<i>n</i> = 302 17.58 , 5.27	<i>n</i> = 164 17.44 , 5.48	<i>n</i> = 324 17.92 , 5.33
Women	<i>n</i> = 301 16.24 , 4.61	<i>n</i> = 350 17.91 , 5.64	<i>n</i> = 271 17.78 , 5.67	<i>n</i> = 164 16.92 , 6.04	<i>n</i> = 288 17.72 , 5.69
BDI-II	<i>n</i> = 1090 11.26 , 12.21	<i>n</i> = 738 10.25 , 12.12	<i>n</i> = 574 9.45 , 11.93	<i>n</i> = 677 10.44 , 12.47	<i>n</i> = 677 10.15 , 12.19
Men	<i>n</i> = 599 10.30 , 11.51	<i>n</i> = 387 9.33 , 11.44	<i>n</i> = 302 8.52 , 11.67	<i>n</i> = 360 9.52 , 11.87	<i>n</i> = 291 11.48 , 12.83
Women	<i>n</i> = 491 12.44 , 12.92	<i>n</i> = 351 11.28 , 12.77	<i>n</i> = 272 10.47 , 12.14	<i>n</i> = 317 11.48 , 13.05	<i>n</i> = 326 11.19 , 8.26

Appendix E: Cross-Sectional Analyses for Time Points 2-5

Cross-Sectional Analyses Time 2

In the Time 2 sample ($n = 739$), the hypothesized structural equation fit the data well, RMSEA = .07, 90% CI (.05, .08), $p < .01$; $\chi^2(18) = 80.9$, $p < .01$; CFI = .98; TLI = .97; SRMR = .03. No alterations were made to this model. All paths were significant at the $p = .01$ level. The specific direct path from Alcohol problems to depressive symptoms was significant ($b = .21$, $p < .01$) and so was the specific indirect path from Alcohol problems to depressive symptoms through dysfunctional attitudes ($b = .10$, $p < .01$). The mediating effect of dysfunctional attitudes accounted for 31% of the total effect ($b = .31$, $p < .01$).

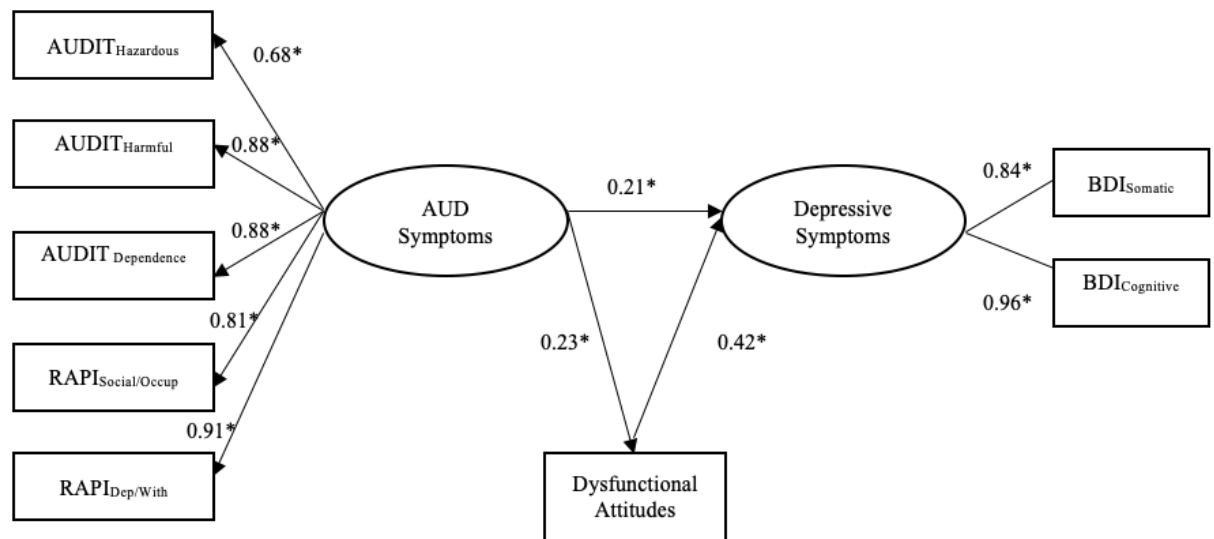

Figure 28. Cross-sectional SEM, time 2.

Cross-Sectional Analyses Time 3

In the Time 3 sample ($n = 574$), the hypothesized structural equation fit the data well, RMSEA = .08, 90% CI (.06, .09), $p < .01$; $\chi^2(18) = 78.6$, $p < .01$; CFI = .98; TLI = .96; SRMR = .04. No alterations were made to this model. All paths were significant at

the $p = .01$ level. The specific direct path from Alcohol problems to depressive symptoms was significant ($b = .20, p < .01$) and so was the specific indirect path from Alcohol problems to depressive symptoms through dysfunctional attitudes ($b = .10, p < .01$). The mediating effect of dysfunctional attitudes accounted for 33% of the total effect ($b = .30, p < .01$).

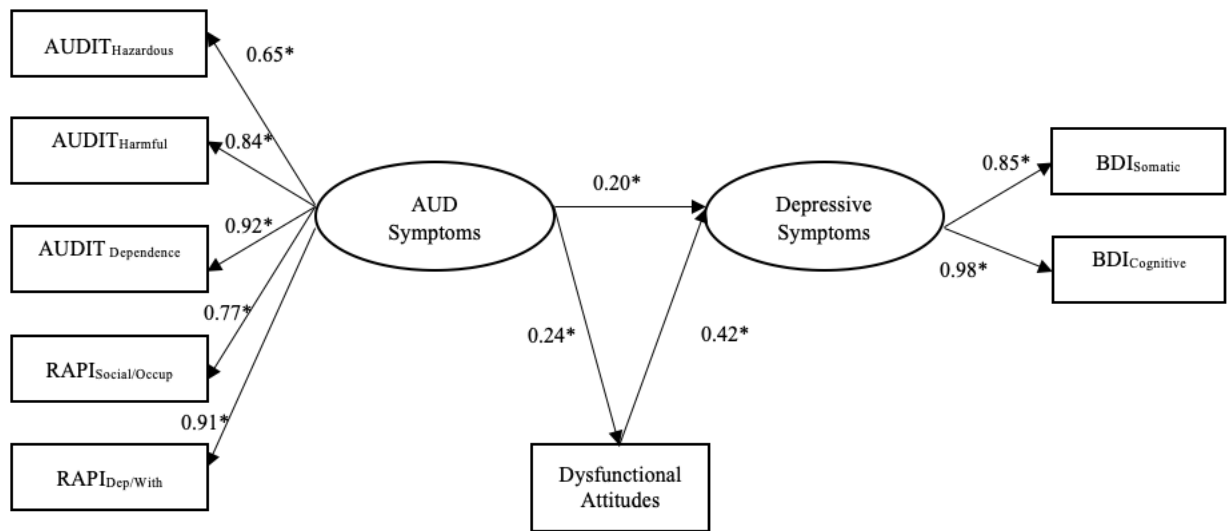

Figure 29. Cross-sectional SEM, time 3.

Cross-Sectional Analyses Time 4

In the Time 4 sample ($n = 677$), the hypothesized structural equation fit the data well, $RMSEA = .07$, 90% CI (.05, .09), $p < .01$, $\chi^2(18) = 74.6, p < .01$; $CFI = .98$; $TLI = .97$; $SRMR = .03$. No alterations were made to this model. All paths were significant at the $p = .01$ level. The specific direct path from Alcohol problems to depressive symptoms was significant ($b = .23, p < .01$) and so was the specific indirect path from Alcohol problems to depressive symptoms through dysfunctional attitudes ($b = .11, p < .01$). The mediating effect of dysfunctional attitudes accounted for 33% of the total effect ($b = .38, p < .01$).

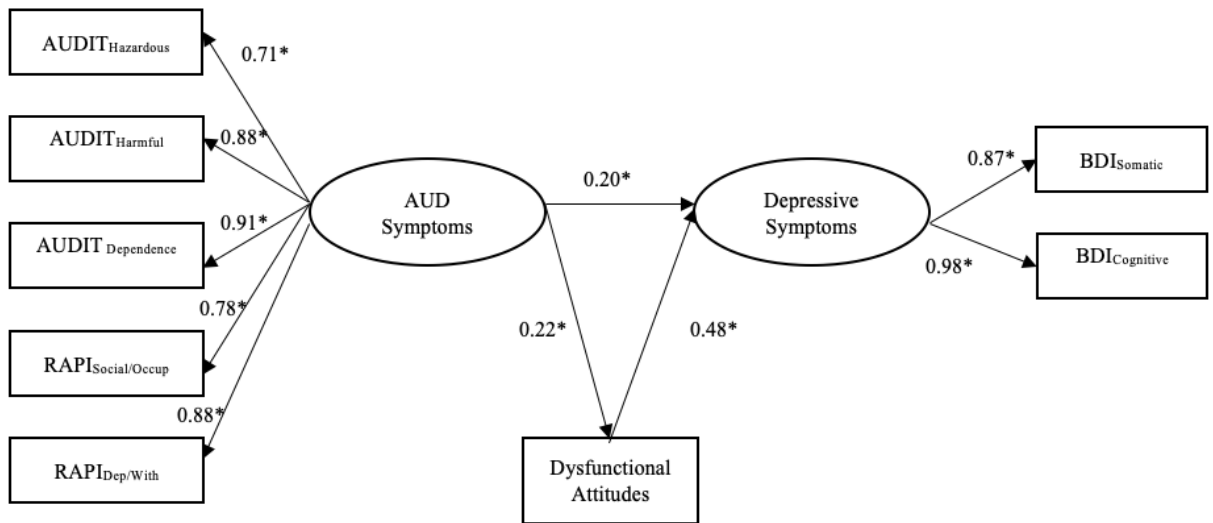

Figure 30. Cross-sectional SEM, time 4.

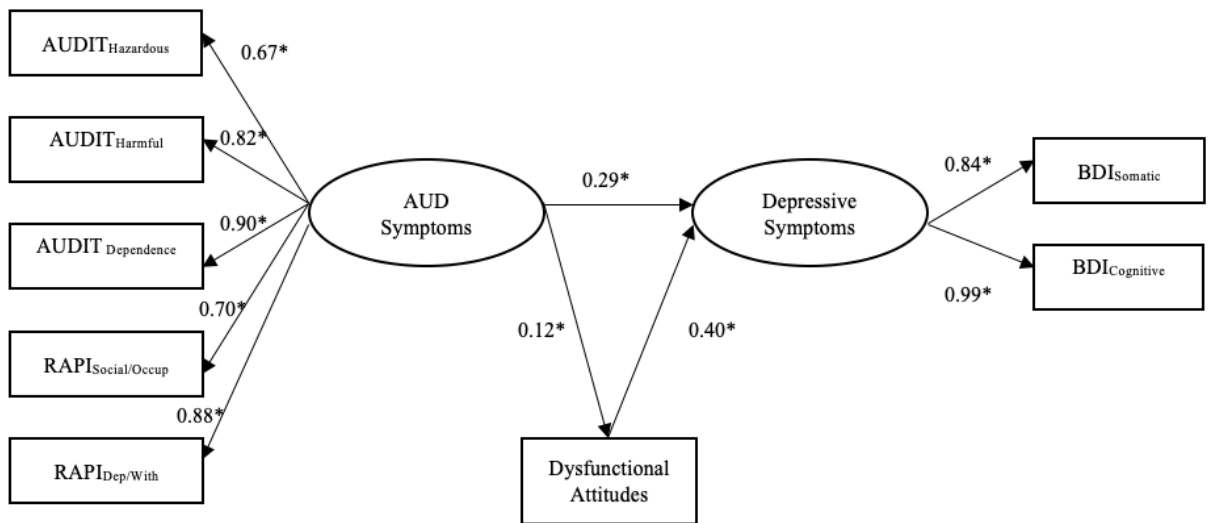

Figure 31. Cross-sectional SEM, time 5.

Cross-Sectional Analyses Time 5

In the Time 5 sample ($n = 617$), the hypothesized structural equation fit the data to an acceptable degree, $RMSEA = .09$, 90% CI (.08, .11), $p < .01$; $\chi^2(18) = 123.2$, $p < .01$;

CFI = .96; TLI = .93; SRMR = .04. No alterations were made to this model. All paths were significant at the $p = .01$ level. The specific direct path from Alcohol problems to depressive symptoms was significant ($b = .30, p < .01$) and so was the specific indirect path from Alcohol problems to depressive symptoms through dysfunctional attitudes ($b = .06, p < .01$). The mediating effect of dysfunctional attitudes accounted for 17% of the total effect ($b = .35, p < .01$).

Appendix F: Longitudinal Findings from the AUDIT Subscales (Community Study)

Hazardous Drinking Subscale

Model from Depressive Symptoms to Alcohol Problems

The hazardous drinking subscale of the AUDIT assesses the amount of alcohol consumption, the typical quantity of consumption, and the frequency of heavy drinking. Isolating this subscale and assessing it separately from the total score will help better understand whether the physical effects of heavy, frequent, drinking are affecting cognitive variables, and subsequent depression. When the full model was tested with the hazardous subscale as the predictor of DAS and BDI-II, the full model fit the data poorly, $n = 1090$, $\chi^2(67) = 1026.85$, $p < .01$; RMSEA = .12, 90% CI (.11, .12), $p < .01$; CFI = .89; TLI = .83; SRMR = .10.

Unlike in the full model, there was a significant direct path from Time 2 hazardous drinking to Time 4 depressive symptoms ($b = .06$, $p = .04$), and significant paths from Time 2 dysfunctional attitudes to Time 3 depressive symptoms ($b = .06$, $p = .01$), and from Time 3 dysfunctional attitudes to Time 4 depressive symptoms ($b = .07$, $p < .01$). The model was also tested with six-month paths only, (Time 1, 3, and 5), and the hypothesized model did not fit the data well, $n = 1090$, $\chi^2(16) = 147.87$, $p < .01$, RMSEA = .11, 90% CI (.11, .12), $p = .01$; CFI = .89; TLI = .83; SRMR = .10. The same significant path from Time 3 dysfunctional attitudes to Time 5 depressive symptoms ($b = .05$, $p = .04$) that emerged in the full model also emerged in this model. There were no significant total direct or indirect effects. There is no evidence that hazardous drinking predicts dysfunctional attitudes at three-month or six-month intervals.

Harmful Drinking Subscale

The harmful drinking subscale of the AUDIT assesses consequences of drinking (guilt after drinking, blackouts, alcohol-related injuries, and family/friends' concerns about the person's drinking). Isolating this subscale will permit an assessment of whether the consequences associated with drinking (rather than the physical effects of drinking) affect cognitive variables and subsequent depression.

When the full model was tested with the harmful subscale as the predictor of DAS and BDI-II, the hypothesized model again poorly fit the data, $n = 599$, $\chi^2(67) = 963.66$, $p < .01$; RMSEA = .12, 90% CI (.11, .13), $p < .01$, CFI = .87; TLI = .80; SRMR = .10. In this model, there was a direct path from Time 3 AUDIT to Time 5 BDI-II ($b = .05$, $p = .05$). Time 3 harmful drinking also predicted Time 4 dysfunctional attitudes ($b = .08$, $p = .03$). Time 2 dysfunctional attitudes predicted Time 3 depressive symptoms ($b = .05$, $p = .01$) and Time 3 dysfunctional attitudes predicted Time 4 depressive symptoms ($b = .07$, $p < .01$).

The model was also tested with six-month paths only, (Time 1, 3, and 5), and the hypothesized model fit the data reasonably well, $n = 1090$, $\chi^2(16) = 140.78$, $p < .01$; RMSEA = .09, 90% CI (.07, .10), $p < .01$, CFI = .96; TLI = .92; SRMR = .05. A significant path emerged from Time 3 dysfunctional attitudes to Time 5 depressive symptoms ($b = .05$, $p = .05$).

Alcohol Dependence Subscale

The alcohol dependence subscale is a combination of cognitive, physiological, and behavioural factors that lead to an inability to control or stop drinking behaviours despite physical or environmental consequences. Dependence includes impaired control over drinking, engaging in excessive behaviours to access alcohol, and morning drinking to

avoid withdrawal. Isolating this subscale permitted an assessment of whether the long-term physiological consequences associated with drinking (rather than the immediate physical effects or the consequences of drinking) affect cognitive variables and subsequent depression. When the full model was tested with only the dependence subscale as the predictor of DAS and BDI-II, the hypothesized model fit the data poorly, $n = 1090$, $\chi^2(67) = 943.05$, $p < .01$; RMSEA = .11, 90% CI (.10, .12), $p < .01$, CFI = .89; TLI = .83; SRMR = .12.

A review of the cross-lagged paths did not reveal any direct or indirect paths from alcohol dependence to depressive symptoms. Rather, Time 3 alcohol dependence positively predicted time 4 dysfunctional attitudes ($b = .09$, $p = .02$), and Time 4 alcohol dependence negatively predicted Time 5 dysfunctional attitudes ($b = -.09$, $p = .02$). Time 2 dysfunctional attitudes predicted Time 3 depressive symptoms ($b = .06$, $p = .01$) and time 3 dysfunctional attitudes predicted Time 4 depressive symptoms ($b = .07$, $p < .01$).

The model was also tested with six-month paths only, (Time 1, 3, and 5), and the hypothesized model fit the data reasonably well, $n = 1090$, $\chi^2(16) = 153.30$, $p < .01$; RMSEA = .09, 90% CI (.09, .12), $p < .01$, CFI = .96; TLI = .91; SRMR = .05. A significant path emerged from Time 3 dysfunctional attitudes to Time 5 depressive symptoms ($b = .05$, $p = .04$).

Summary of AUDIT Subscale Findings

A review of the three-month cross-lagged paths revealed some evidence that harmful drinking and alcohol dependence predict dysfunctional attitudes three months later, although this relationship is complicated. From August to November, changes in harmful drinking and alcohol dependence predicted increases in dysfunctional attitudes,

whereas from November to February, changes in harmful drinking and alcohol dependence predicted decreases in dysfunctional attitudes. Dysfunctional attitudes predicted depressive symptoms at three-month and six-month intervals in all models. Only hazardous drinking and harmful drinking predicted depressive symptoms directly, six months later. There was no evidence from these models that alcohol problems predict depressive symptoms one year later.

Model from Depressive Symptoms to Alcohol Problems

The initial model for this longitudinal model shows poor fit ($n = 1091$), RMSEA = .11, 90% CI (.12, .12), $p < .01$; $\chi^2(67) = 99.17$, $p < .01$; CFI = .89; TLI = .83; SRMR = .07. There were no significant paths from dysfunctional attitudes to hazardous drinking. There were also no direct paths from depressive symptoms to hazardous drinking. The only paths that emerged were significant cross-lagged paths from Time 1 BDI-II to Time 2 DAS ($b = .13$, $p = .00$), Time 2 BDI-II to Time 3 DAS ($b = .12$, $p < .01$) and Time 3 BDI-II to Time 4 DAS ($b = .17$, $p < .01$). There is more evidence that hazardous drinking predicts depressive symptoms than depressive symptoms predicting hazardous thinking. The six-month cross-lagged model fit the data very well, ($n = 1091$), RMSEA = .08, 90% CI (.07, .09), $p < .01$; $\chi^2(16) = 124.66$, $p < .01$; CFI = .97; TLI = .93; SRMR = .03. In this model, there was a significant path from Time 1 BDI-II to Time 3 DAS ($b = .12$, $p = .00$) and from Time 3 BDI-II to Time 5 DAS ($b = .13$, $p < .01$). There were no paths from dysfunctional attitudes or from depressive symptoms to hazardous drinking.

Results for the Path Model from BDI-II to AUDIT, Harmful Drinking

The initial model for these longitudinal data demonstrated a poor fit ($n = 1091$), RMSEA = .11, 90% CI (.10, .11), $p < .01$; $\chi^2(67) = 921.17$, $p < .01$; CFI = .89; TLI =

.84; SRMR = .08. In this model, unlike the model with the total AUDIT scores, there was a significant direct path from Time 3 harmful drinking to Time 5 depressive symptoms ($b = .08, p = .01$). There were also significant paths from Time 1 BDI-II to Time 2 DAS ($b = .13, p = .00$), from Time 2 BDI-II to Time 3 DAS ($b = .12, p < .01$), and from Time 3 BDI-II to Time 4 DAS ($b = .17, p < .01$). There was also a significant path from Time 2 DAS to Time 3 harmful drinking ($b = .06, p = .04$). No significant indirect effects were present in this model. Therefore, again there is evidence that depressive symptoms predict dysfunctional attitudes over time. There was also some evidence in this model that dysfunctional attitudes predict harmful drinking patterns, and that depressive symptoms predict harmful drinking patterns. The six-month cross-lagged paths also revealed the same significant paths from depressive symptoms to dysfunctional attitudes over six-month periods. There were no direct or indirect effects in this model.

Results for the Path Model from BDI-II to AUDIT, Alcohol Dependence and Withdrawal

The initial model, again, generally poorly fits the data ($n = 1091$), RMSEA = .08, 90% CI (.07, .09), $p < .01$; $\chi^2(67) = 903.75, p < .01$; CFI = .96; TLI = .92; SRMR = .08. There were no direct paths from depressive symptoms to alcohol dependence. There were significant paths from Time 1 BDI-II to Time 2 DAS ($b = .13, p = .00$), from Time 2 BDI-II to Time 3 DAS ($b = .12, p < .01$), and from Time 3 BDI-II to Time 4 DAS ($b = .17, p < .01$). There was also a significant path from Time 2 DAS to Time 3 alcohol dependence and withdrawal ($b = .05, p = .05$). No significant indirect effects were present in this model. Therefore, again there is evidence that depressive symptoms predict dysfunctional

attitudes over time. There was also some evidence in this model that dysfunctional attitudes predicted alcohol dependence and withdrawal.

The six-month cross-lagged path model fit the data very well, ($n = 1091$), RMSEA = .12, 90% CI (.10, .11), $p < .01$; $\chi^2(16) = 130.30$, $p < .01$; CFI = .89; TLI = .84; SRMR = .04. There were the same significant paths from Time 1 BDI-II to Time 3 DAS ($b = .12$, $p < .01$) and from Time 3 BDI-II to Time 5 DAS ($b = .13$, $p < .01$) as there were in the other models. There was also a significant path from Time 1 DAS to Time 3 alcohol dependence and withdrawal ($b = .06$, $p = .05$). No significant direct or indirect paths emerged.

Appendix G: Data Cleaning and Analysis of Measures for Student Study

Attention Checks

Test items were re-coded as either 0 = fail or 1 = pass so that total number of failed attention checks could be computed. In Time 1 ($n = 321$), 16 participants (5%) failed one attention check, two participants (.6%) failed two attention checks, and one participant failed three attention checks (.3%). In Time 2 ($n = 212$), four participants failed one attention check (2%) and no one failed more than one. Analyses were completed with and without participants who failed attention checks. There were no differences between the samples that including participants who failed attention checks and those who did not. Therefore, all participants who failed attention checks were retained in the final analyses.

Outliers

No outliers were present on the AUDIT, RAPI, RRS, DMQ-R, BDI-II, DAS, or VAS. This is not surprising, as the general range for these scales is relatively low. Outliers are more common in data with indefinite ranges (e.g., response time data).

Analysis of Non-Normality

Skewness and kurtosis were then analyzed for data at each time point. The kurtosis cutoff points are driven by the literature summarized in Ory & Mokhtarian (2009, 2010), which suggests that kurtosis values of one or less indicate negligible non-normality, values between 3.5 and 10 indicate moderate non-normality, and values greater than 10 indicate severe non-normality. The generally acceptable cutoff for skewness is 2 (Kim, 2013). The findings for skewness and kurtosis were similar across time points, and thus only Time 1 data are presented here (*Table 7*) to offer an example of the findings. For Time 1, the AUDIT withdrawal/dependence subscale indicated skewness slightly above

the accepted levels, indicating some non-normality. A review of the distribution of scores for this subscale demonstrates that 75% of participants scored a zero or one on this subscale, suggesting that most students are not physiologically dependent on alcohol.

The AUDIT withdrawal/dependence, RAPI Total, and RAPI withdrawal/dependence also indicated moderate non-normality according to their degree of kurtosis. Again, a review of the distribution for these scales indicates that most participants scored the lower ends of these subscales. For the RAPI withdrawal/dependence subscale, 75% of participants fell below a score of four, and on the total RAPI score, 77% of participants' scores fell in the bottom 25% of scores. Therefore, significant alcohol problems were not common in this sample, which would be expected in a community sample. These minor concerns with non-normality were taken into consideration during the statistical approach used.

Missing Data

During each time point, the data were scanned visually to see if any participants had large proportions of missing data. At times, participants did miss specific items while completing questionnaires. This type of missing data was a surprisingly rare occurrence (likely because participants were made aware of any unanswered items when they clicked "next" and had to click "yes, I want to proceed without answering that question" before moving to the next page). For example, in Time 1, five people were missing an item on a questionnaire. These data points were replaced with the mean for the other responses on that questionnaire for that person.

No one was missing any data in Time 2. Missing data points for variables where means could not be imputed (e.g., demographic data) were deleted from analyses using

listwise deletion. The sample sizes for each time point, once data were cleaned, were as follows (Time 1: $N = 321$, Time 2: $n = 212$). MLR estimations (Yuan & Bentler, 2008) of missing data between time points were employed using Mplus Version 7.4 (Muthén & Muthén, 1998-2015).

Equivalence of DAS A and DAS B

The two versions of the DAS were compared to each other using a paired-samples t-test for each wave of data collection. Across all time points, there was a significant difference between the two version of the DAS (Time 1, $t(310) = -4.98, p < .01$; Time 2, $t(196) = -8.63, p < .01$) At each time point, the mean for DAS B was higher than DAS A (Time 1, $M_{DasA} = 18.30, SD = 4.54$; $M_{DasB} = 19.38, SD = 4.36$; Time 2, $M_{DasA} = 17.86, SD = 4.55$; $M_{DasB} = 19.83, SD = 4.02$). Correlations between the DAS A and DAS B at each time point were also much lower than expected ($r_{Time1} = .64, r_{Time2} = .73$). These findings replicate the findings from the community sample.

Effect of the Mood Prime on Mood

Each participant who was in the priming condition completed a Visual Analog Scale to rate their mood from sad to happy (on a 100-point line) before the sad mood prime, after the sad mood prime, and after the happy mood prime. Participants began the study in a relatively positive mood, reported significantly lower mood (a more neutral mood) following the sad mood prime and significantly improved mood after the happy mood prime. In Time 1, a significant increase in dysfunctional attitudes was found ($t(310) = -2.67, p < .01$) from pre-prime ($M = 18.54, SD = 4.42$) to post-prime ($M = 19.14, SD = 4.53$). Therefore, there is evidence that the prime succeeded in activating latent dysfunctional attitudes at Time 1.

Table 12. AUDIT, RAPI, DAS, and BDI-II Scores Across Three Months, By Sex (Student Study).

Measure	Time 1 <i>n</i> , <i>M</i> (<i>SD</i>) September 2017	Time 2 <i>M</i> (<i>SD</i>) December 2017
AUDIT	<i>n</i> = 260, 8.17 (8.17)	<i>n</i> = 171, 7.60 (6.26)
Men	<i>n</i> = 64, 10.17 (7.18)	<i>n</i> = 40, 9.90 (7.54)
Women	<i>n</i> = 196, 7.52 (5.28)	<i>n</i> = 131, 6.90 (5.66)
RAPI	<i>n</i> = 260, 6.91 (6.85)	<i>n</i> = 171, 6.41 (7.24)
Men	<i>n</i> = 64, 7.95 (7.90)	<i>n</i> = 40, 8.50 (8.64)
Women	<i>n</i> = 196, 6.56 (6.45)	<i>n</i> = 132, 5.78 (6.67)
DAS	<i>n</i> = 321, 19.36 (4.67)	<i>n</i> = 212, 19.22 (4.57)
Men	<i>n</i> = 80, 19.31 (3.98)	<i>n</i> = 51, 19.76 (3.82)
Women	<i>n</i> = 161, 19.05 (4.79)	<i>n</i> = 350, 17.91 (5.64)
BDI-II	<i>n</i> = 321, 10.55 (8.26)	<i>n</i> = 212, 12.71 (10.45)
Men	<i>n</i> = 80, 8.97 (7.46)	<i>n</i> = 51, 12.16 (9.53)
Women	<i>n</i> = 241, 11.07 (8.45)	<i>n</i> = 161, 12.88 (10.75)
RRS	<i>n</i> = 320, 22.75 (5.25)	<i>n</i> = 212, 22.11 (5.59)
Women	<i>n</i> = 240, 23.25 (5.33)	<i>n</i> = 161, 22.63 (5.75)
Men	<i>n</i> = 80, 21.25 (4.68)	<i>n</i> = 51, 20.47 (4.75)
DMQ		
Social	<i>n</i> = 260, 13.38 (5.03)	<i>n</i> = 172, 13.45 (5.22)
Women	<i>n</i> = 196, 13.76 (4.92)	<i>n</i> = 132, 13.15 (5.22)
Men	<i>n</i> = 64, 14.00 (5.38)	<i>n</i> = 40, 14.42 (5.15)
Coping	<i>n</i> = 260, 12.90 (3.76)	<i>n</i> = 172, 12.09 (4.39)
Women	<i>n</i> = 196, 12.06 (3.66)	<i>n</i> = 132, 11.93 (4.25)
Men	<i>n</i> = 64, 11.81 (4.08)	<i>n</i> = 40, 12.60 (4.85)
Enhancement	<i>n</i> = 260, 9.89 (3.59)	<i>n</i> = 172, 9.74 (4.12)
Women	<i>n</i> = 196, 9.83 (3.38)	<i>n</i> = 132, 9.68 (4.05)
Men	<i>n</i> = 64, 10.07 (4.19)	<i>n</i> = 40, 9.92 (4.39)
Conformity	<i>n</i> = 260, 13.38 (4.33)	<i>n</i> = 172, 12.63 (4.65)
Women	<i>n</i> = 196, 13.40 (4.21)	<i>n</i> = 131, 12.51 (4.58)
Men	<i>n</i> = 64, 13.32 (4.71)	<i>n</i> = 40, 13.00 (4.91)

Appendix H: A Description of How Variables Were Associated with Each Other in the Student Study and Changes in Variables over Time

Table 8 shows that all alcohol measures generally correlated strongly with each other. The lowest correlation, which was moderate in size, was the correlation between the Audit Hazardous and Audit Dependence/Withdrawal subscales ($r = .40$). The BDI-II subscales correlated strongly with each other, and with the total score. While it is not typical to separate these subscales in analyses (given the very high internal reliability of the BDI-II), they were separated in this study to assess whether the cognitive symptoms of depression, specifically, were influenced by changes in cognitive variables. They were also used separately as indicators of the latent variable “depressive symptoms” during structural equation modeling analyses (latent variables reduce error variance more so than observed variables). The cognitive variables generally correlated moderately with each other. The RRS and the DAS demonstrated a moderate correlation ($r = .31$) as did the SRET (Negatively-biased Information Processing) and the DAS ($r = .34$). The RRS and the SRET has a weaker association ($r = .28$).

Alcohol Measures and BDI-II

Correlations between the alcohol measures and the depression measures range from very small to moderate. Specifically, the Hazardous drinking subscale of the AUDIT (which measures frequency and amount of alcohol consumption) had the weakest association with the depressive symptoms ($r = .06$). The RAPI total score, which measures problems related to alcohol use (e.g., getting into fights, failing to fulfil responsibilities) was most highly associated with overall depressive symptoms ($r = .36$), cognitive symptoms ($r = .29$) and somatic symptoms ($r = .39$). The correlation between

the Hazardous drinking subscale and total BDI-II scores was statistically significantly lower than the correlations between total BDI-II scores and the total RAPI scores ($n = 260$, z -score = 3.59, $p < .01$). Therefore, the association between depressive symptoms and drinking problems is statistically significantly stronger than the association between depressive symptoms and the amount or frequency of drinking.

Alcohol Measures and Cognitive Variables

Correlations between the alcohol measures and the cognitive variables were small. They were strongest for the DAS. The RAPI correlated more strongly with the DAS compared to the AUDIT and its subscales. Specifically, the Dependence/Withdrawal ($r = .04$) and Hazardous drinking ($r = .05$) subscales of the AUDIT showed the weakest correlations with the DAS. The Social and Occupational Consequences of Drinking subscale of the RAPI had the strongest correlation with the DAS ($r = .21$). Therefore, there is more evidence that the consequences of drinking, rather than the amount or frequency of drinking, or the physiological consequences of drinking, are related to dysfunctional attitudes.

The correlation between DAS and Hazardous drinking was not significantly weaker than the correlation between DAS and the social and occupational consequences subscale of the RAPI ($n = 260$, $z = 1.84$, $p = .06$). The correlations between DAS and the Dependence/Withdrawal subscale of the AUDIT was significantly weaker than the correlation between DAS and the social and occupational consequences subscale of the RAPI ($n = 260$, $z = 1.96$, $p = .05$). Correlations between the RRS and the alcohol measures were very small. The largest correlations, which were statistically significant, were with the RRS and the total RAPI score ($r = .13$) and the RAPI subscale, social and

occupational consequences of drinking ($r = .14$). The smallest correlation was with the hazardous drinking subscale of the AUDIT and the RRS ($r = -.01$). These differences were not statistically significant. The correlations between the hazardous subscale and the RRS, and the RAPI total and the RRS were not significantly different from each other ($z = 1.60, p = .11$). The correlations between the hazardous subscale and the RRS, and the RAPI social and occupational consequences subscale and the RRS were also not significantly different from each other ($z = 1.71, p = .08$).

Correlations between the alcohol measures and the Negatively-biased Information Processing Bias calculation of the SRET were all small and non-significant. Therefore, there is little indication that either ruminative thinking or negatively-biased information processing are associated with alcohol use or alcohol problems. Rather, there is more evidence that dysfunctional attitudes are associated with these measures.

Depressive Symptoms and Cognitive Variables

Correlations between the DAS and the BDI-II were moderate. The weakest correlation was between the DAS and the somatic subscale of the BDI-II ($r = .40$). The DAS correlated equally strongly with the BDI-II total score and the cognitive subscale ($r = .47$). These correlations were not statistically significantly different from each other ($n = 260, z\text{-score} = .98, p = .33$).

Correlations between the RRS and the BDI subscales were small to moderate, ranging from $r = .28$ with the somatic subscale of the BDI-II to $r = .31$ with the total BDI-II scores. These correlations were not statistically significantly different from each other ($n = 260, z\text{-score} = .25, p = .80$). Correlations with the Negatively-biased Information Processing and the BDI-II were moderate, and ranged from $r = .40$ with the

somatic subscale of the BDI-II to $r = .49$ with the cognitive subscale. These correlations were not statistically significantly different from each other ($n = 260$, z -score = 1.27, $p = .20$). Overall, dysfunctional attitudes and negatively-biased information processing were significantly more strongly associated (e.g., the correlation between the RRS and BDI-II total and with the DAS and BDI-II total were significantly different; $n = 260$, $z = 2.14$, $p = .03$) with depressive symptoms compared to ruminative thinking. Cognitive measures were more strongly associated with depressive symptoms, compared to alcohol use.

Correlations Between Primary Variables and Secondary Variables at Time 1

The DMQ and other calculations from the SRET task, including positive information processing bias, total words recalled, positive words recalled, and negative words recalled, were also assessed to determine whether they were associated with measures of alcohol problems and depressive symptoms. The four subscales of the DMQ show moderate to strong associations with the alcohol measures. They show small to moderate associations with the DAS and no significant association with the RRS or the Negatively-biased Information Processing measure of the SRET. They also show small associations with the measures of depression (see *Table 13*). For a review of the correlations between secondary variables, see *Table 14*.

Participants' total positive words recalled calculation showed small associations with depression measures and no association with the alcohol measures. Participants' total negative words recalled demonstrated a small association with the cognitive subscale of the BDI-II. Neither participants' total number of words recalled nor their positive information processing bias calculation were associated with either alcohol or

depression measures. These SRET calculations did correlate significantly with each other. The size of these correlations ranged from small to large.

Therefore, consistent with the literature (Cooper, 1994; e.g., Foster et al., 2014; Kuntsche et al., 2006, 2006) there is evidence in this student sample that drinking motives are associated with measures of both depression and alcohol use. Coping motives are the only cognitive measure in this study that show consistent moderate-strong associations with alcohol use.

Changes in Variables Across Time

To determine whether changes in depressive symptomatology, alcohol problems, ruminative thinking, and drinking motives, information processing biases, and dysfunctional attitudes significantly changed over time, and across sex at each time point, a mixed between/within subjects repeated-measures ANOVA was conducted with sex as the between-subjects variables (2 levels: male and female) and time as the within-subjects variables (2 levels: Time 1 and Time 2) for each measures using IBM SPSS Statistics Version 25. Participants with missing data at any time point were omitted using listwise deletion.

For the alcohol measures, a main effect of sex was found on the AUDIT, $F(1, 163) = 5.58, p = .02$, partial $\eta^2 = .03$, such that men ($M = 9.87, SD = 6.11$) had higher levels of drinking problems across time than did women ($M = 7.34, SD = 5.91$). Paired-samples *t*-tests were also conducted on the subscales to determine whether the frequency and amount of alcohol use, alcohol dependence and withdrawal symptoms, or harmful drinking changed over time. The only difference found was in hazardous drinking, such that students drank less alcohol, less often at Time 2 ($M = 2.76, SD = 2.8$) compared to

Time 1 ($M = 2.46$, $SD = 2.68$, $t(164) = 2.76$, $p = .01$). There were no significant differences between group or across time for the RAPI.

A main effect of time was found for depressive symptoms, such that they decreased, $F(1, 207) = 12.31$, $p < .01$, $\eta^2 = .06$, from Time 1 ($M = 11.04$, $SD = 8.70$) to Time 2 ($M = 12.70$, $SD = 10.53$), across sexes. There was also a main effect of sex found on the RRS, $F(1, 206) = 9.74$, $p = .02$, $\eta^2 = .05$, such that women ($M = 23.00$, $SD = 4.88$) had higher levels of ruminative thinking, across time, than men ($M = 20.52$, $SD = 4.92$). A review of the four motivations for drinking did not reveal any significant effects of time or sex on social or enhancement motivations for drinking. Conformity motivations (i.e., drinking to “fit in”) significantly decreased from Time 1 ($M = 13.36$, $SD = 4.99$) to Time 2 ($M = 12.72$, $SD = 5.37$), across sexes, $F(1, 162) = 5.43$, $p = .02$, $\eta^2 = .03$. A significant interaction was found for coping motives (i.e., drinking to cope with low mood or anxiety), $F(1, 163) = 4.06$, $p = .04$, $\eta^2 = .06$. From Time 1 to Time 2, men significantly increased their drinking to cope motivations ($M_{T1} = 11.62$, $SD = 3.84$, $M_{T2} = 12.60$, $SD = 4.85$), whereas women remained stable on this measure ($M_{T1} = 11.98$, $SD = 3.69$, $M_{T2} = 11.84$, $SD = 4.16$).

Negative information processing decreased over time, $F(1, 195) = 70.06$, $p < .01$. The degree to which participants both endorsed negative adjectives as “like them” and later recalled them (after controlling for the total number of words recalled) was higher in Time 1 ($M = .34$, $SD = .32$) than in Time 2 ($M = .16$, $SD = .14$). There were no sex differences in this effect. There were no differences in dysfunctional attitudes across time or sex, and no interaction effects.

Table 13. Correlations Between Primary Variables and Secondary Variables at Time 1, Student Study

	AUDIT Total	AUDIT Hazardous	AUDIT Harmful	AUDIT Dependence	RAPI Total	RAPI Dependence/ Withdrawal	RAPI Social/ Occupational	DAS	BDI- II Total	BDI-II Cognitive	BDI-II Somatic	RRS	SRET Negatively Biased Information Processing
DMQ Enhancement	.44**	.32**	.39**	.43**	.53**	.47**	.50**	.34**	.28**	.21**	.31**	.09	-.02
DMQ Coping	.50**	.41**	.42**	.41**	.48**	.56**	.43**	.22**	.21**	.20**	.19**	.10	-.08
DMQ Social	.65**	.59**	.55**	.45**	.55**	.51**	.51**	.24**	.16**	.15*	.15*	.09	.01
DMQ Conformity	.66**	.63**	.54**	.43**	.56**	.51**	.52**	.21**	.18**	.14*	.19**	.07	-.01
SRET Total Words Recalled	.06	.06	-.01	.01	-.05	-.05	-.04	.06	-.03	-.03	-.05	.08	.33**
SRET Total Positive Recalled	-.02	.00	-.04	-.01	-.08	-.08	-.08	.01	-.11*	.14**	-.12*	.05	.13*
SRET Total Negative Recalled	.07	.10	.03	.03	.01	.01	.02	.08	.08	.19**	.04	.08	.43**
SRET Positive Information Processing	-.02	-.04	-.01	.00	-.02	-.04	-.00	.12	.01	.01	.01	.08	.12*

Note: Correlations significant at $p < .05$ are marked with *, and $p < .01$ are marked with **. $N = 260$ (listwise deletion)

Table 14. Correlations Between Secondary Variables at Time 1, Student Study

	DMQ _{Enhancement}	DMQ _{Coping}	DMQ _{Social}	DMQ _{Conformity}	SRET _{Total Words Recalled}	SRET _{Total Positive Recalled}	SRET _{Total Negative Recalled}	SRET _{Positive Information Processing}
DMQ _{Enhancement}	1							
DMQ _{Coping}	.63**	1						
DMQ _{Social}	.68**	.71**	1					
DMQ _{Conformity}	.70**	.75**	.87**	1				
SRET _{Total Words Recalled}	-.00	-.01	.04	.04	1			
SRET _{Total Positive Recalled}	.01	-.03	.02	.03	.82**	1		
SRET _{Total Negative Recalled}	-.02	.02	.04	.03	.77**	.27**	1	
SRET _{Positive Information Processing}	.08	.02	.05	.07	.66**	.81**	.12**	1

Note: Correlations significant at $p < .05$ are marked with *, and $p < .01$ are marked with **. $N = 260-320$ (listwise deletion)

Appendix I: The CFA of Alcohol Problems, Coping Motives, and Depressive Symptoms, Student Study

The hypothesized model assessing the general, cross-sectional, association between alcohol problems, coping motives, and depressive symptoms fit the data well, at Time 1 $n = 318$, $\chi^2(17) = 39.22$, $p < .01$, RMSEA = .06, 95% CI (.04, .09), $p = .17$, CFI = .98, TLI = .96, SRMR = .04. All correlations were significant at the $p = .05$ level.

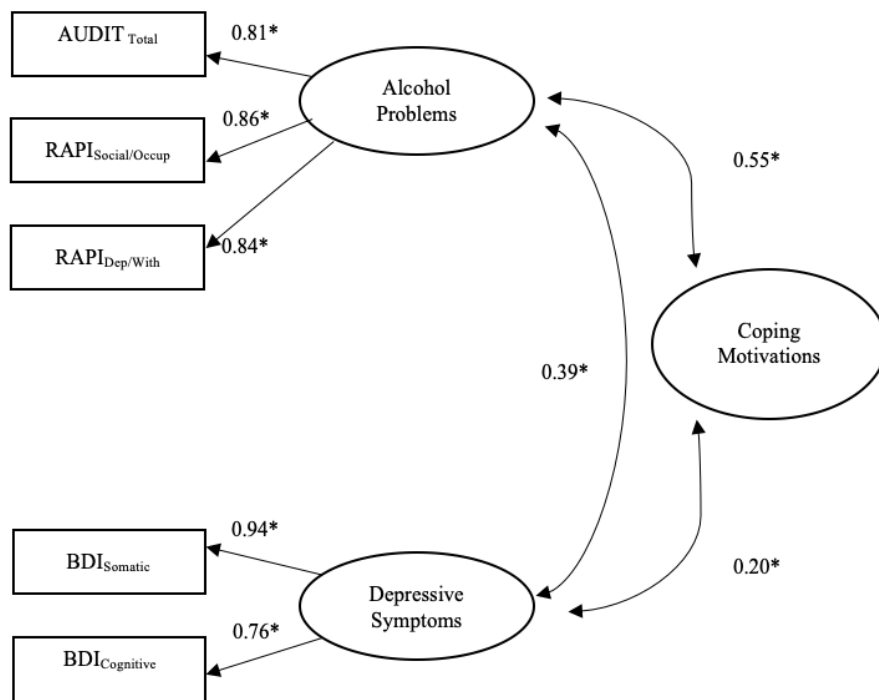

Figure 32. Cross-sectional CFA with alcohol problems, coping motives, and depressive symptoms (time 1).

Curriculum Vitae

Name: Monica Tomlinson

Post-secondary Education and Degrees: Doctor of Philosophy
The University of Western Ontario
London, Ontario, Canada
2015-2020

Master of Science
The University of Western Ontario
London, Ontario, Canada
2013-2015

Bachelor of Arts (Hons.)
McGill University
Montreal, Quebec, Canada
2007-2011

Honours and Awards: Social Science and Humanities Research Council (SSHRC)
Doctoral Fellowship
2017-2020

Ontario Graduate Scholarship
2016-2017

Related Work Experience: Junior Clinical Associate
McKenzie Zayed
2018-Present

Clinical Assistant
LaRose Psychology Professional Corporation
2016-Present

Research Assistant
The University of Western Ontario
2017-2018

Teaching Assistant
The University of Western Ontario
2013-2018

Publications:

- Tomlinson, M.F & Wright, J.D.** (2018). Identifying the “therapy targets” for treating the negative symptoms of psychosis using cognitive behavioral therapy. *Journal of Cognitive Psychotherapy*, 32(3), 1-17. [http:// dx. doi. org/ 10. 1891/ 0889- 8391. 32.3](http://dx.doi.org/10.1891/0889-8391.32.3)
- Wright, J.D. & **Tomlinson, M.F.** (2018). Personality profiles of Hillary Clinton and Donald Trump: Fooled by your own politics. *Personality and Individual Differences*, 128, 21-24. doi: 10.1016/j.paid.2018.02.019
- Tomlinson, M.** (2018) A theoretical and empirical review of dialectical behaviour therapy within forensic psychiatric and correctional settings worldwide. *International Journal of Forensic Mental Health*. Advanced online publication. doi. 10.1080/14999013.2017.1416003
- Dozois, D. J. A. & **Tomlinson, M. F.** (2018). Chapter 4: Psychological assessment. In D.J.A Dozois (Ed.) *Abnormal psychology: Perspectives* (5th edition). Toronto, ON: Pearson Education Canada.
- Tomlinson, M & Hoaken, P.** (2017). The potential for a skills-based dialectical behaviour therapy program to reduce aggression, anger, and hostility in a Canadian forensic psychiatric sample: A pilot study. *International Journal of Forensic Mental Health*, 16(3), 215-226.
- Tomlinson, M., Brown, M., Hoaken, P.** (2016). Recreational drug use and human aggressive behaviour: A comprehensive review since 2003. *Aggression and Violent Behavior*, 27, 9-29.
- Chalupa, A. A. & **Tomlinson, M.** (2015). Migration and survival: An analysis of memory, identity, solidarity, and coping among the gulag survivors of WWII. In W. Owczarski and M. V. F. Cremasco (Eds.), *Memory, Identity, and Solidarity* (225-239). Gdansk: Cambridge University Press.
- Tomlinson, M. F.** (2015). The impact of dialectical behaviour therapy on aggression, anger, and hostility in a forensic psychiatric population. (Master’s thesis). The University of Western Ontario. Paper 3005.
- Tomlinson, M.** (2013). *Learning from lives that have been lived*. Montreal, QC: Douglas Mental Health University Institute.
<https://assets.documentcloud.org/documents/708953/suicide-report-nunavut-english.pdf>