

Spring 2019

AutoJack - Hydraulic Powertrain System

Tyce Vu
vuty@cwu.edu

Follow this and additional works at: <https://digitalcommons.cwu.edu/undergradproj>

 Part of the [Applied Mechanics Commons](#), [Automotive Engineering Commons](#), [Computer-Aided Engineering and Design Commons](#), [Electro-Mechanical Systems Commons](#), [Energy Systems Commons](#), [Manufacturing Commons](#), [Other Engineering Commons](#), [Other Materials Science and Engineering Commons](#), [Other Mechanical Engineering Commons](#), [Risk Analysis Commons](#), and the [Structural Materials Commons](#)

Recommended Citation

Vu, Tyce, "AutoJack - Hydraulic Powertrain System" (2019). *All Undergraduate Projects*. 94.
<https://digitalcommons.cwu.edu/undergradproj/94>

This Undergraduate Project is brought to you for free and open access by the Undergraduate Student Projects at ScholarWorks@CWU. It has been accepted for inclusion in All Undergraduate Projects by an authorized administrator of ScholarWorks@CWU. For more information, please contact scholarworks@cwu.edu.

AutoJack

Hydraulic Powertrain System



By

Tyce Vu

Project Partner: Nick Stadelman

TABLE OF CONTENTS

Page Number (#)

Abstract	4
1. Introduction	4
a. Description.....	4
b. Motivation.....	4
c. Function Statement.....	4
d. Requirements.....	4
e. Engineering Merit.....	4-5
f. Scope of Effort.....	5
g. Success Criteria.....	5
2. Design and Analyses	5
a. Approach.....	6
b. Design Description.....	6
c. Benchmark.....	7
d. Performance Predictions.....	7-8
e. Description of Analyses.....	8
f. Scope of Testing and Evaluation.....	8
g. Analyses (Green Sheets found in Appendix A)	8-15
h. Parts of Device.....	15-16
i. Device Assembly.....	16
j. Tolerances.....	16
k. Safety Factors	16
3. Methods and Construction	16
a. Description.....	16-18
b. Drawing Tree	19
c. Parts List and Labels.....	19
d. Manufacturing Issues.....	19-20
e. Discussion of Assembly.....	20
f. M/C01.....	20
g. M/C02.....	21
4. Testing Method	22
a. Introduction.....	22
b. Method/Approach/Test Description.....	22-23
c. TEST.....	23
d. TES01.....	24
e. TES02.....	24

5.	Budget/Schedule/Project Management	24
a.	Proposed Budget.....	24
b.	Proposed Schedule (Milestones).....	25
c.	Project Management.....	25-26
d.	SCH01.....	26
e.	BUDG - B.....	27
f.	SCHD.....	28
g.	BUDG - C.....	28
6.	Discussion	28
a.	Design Evolution/Performance Creep.....	28
b.	Project Risk Analysis.....	28
c.	Project Documentation.....	28
d.	Next Phase.....	28
e.	DIS01 - B.....	28-29
f.	DIS02 - B.....	29-30
g.	DIS01 - C.....	30-31
h.	DIS02 - C.....	33
7.	Conclusion	30
8.	Acknowledgements	31
9.	References	32
10.	Appendix A – Analyses (Green Sheets A-1 through A-12)	33-45
11.	Appendix B – Drawings (ANSI Y14.5 Drawings B-1 through B-12)	46-57
12.	Appendix C – Parts List (Excel Spreadsheet)	58
13.	Appendix D – Budget (Excel Spreadsheet)	58
14.	Appendix E – Schedule (Excel Gantt Chart)	59-60
15.	Appendix F - Expertise and Resources	60
16.	Appendix G –Testing Data	61
17.	Appendix H – Evaluation Sheet	62
18.	Appendix I – Testing Report	63
19.	Appendix J – Job Hazard Analysis Form	64
20.	Appendix K – Resume	65

ABSTRACT

A primary problem for mechanics and automotive enthusiasts is the risk associated with lifting and securing a vehicle with conventional jack stands. Often times, improper jack-stand installation results in the vehicle collapsing unexpectedly, causing injury and/or death. This problem can be minimized through the application of a newly re-designed vehicle lifting system. The conventional method for lifting cars is time consuming and can be unsafe in many circumstances. A better, safer, and more efficient lift design was needed; the AutoJack. The approach of the AutoJack design was entirely focused on the safety of lifting a vehicle. Safety was improved by creating an automated, hydraulically powered system that doesn't require the user to maneuver under the vehicle to lift or position jack stands. In doing so, the design has removed the operator from a potentially hazardous environment, maximizing safety. The frame design of the AutoJack features a contact area of 4 square feet, a massive improvement over the 4in² standard stability area. Compared to the standard 2-ton floor jack, the AutoJack has a 500% increase in maximum load capacity, a 27% greater maximum lift capacity, a lift speed increase of 100% (2in/s to 4in/s), an operational time reduction of 30%, a jack-to-vehicle contact area (safety) increase of 14,400% (4in² to 4ft²), and a total cost reduction of 40%. The AutoJack is also user-friendlier since the user is only required to slide the device under the vehicle. This device maximizes safety while saving time and money. The AutoJack will save lives.

(1) INTRODUCTION

(a) Description:

A primary problem for mechanics and automotive enthusiasts is the risk associated with lifting and securing a vehicle with conventional jack stands. Often times, improper jacking/jack-stand installation results in the vehicle collapsing unexpectedly. When this happens, personnel near and under the vehicle can be seriously injured and/or killed. From an engineering standpoint, this problem can be minimized through the application of a newly re-designed vehicle lifting system.

(b) Motivation:

This primary motivation behind this project is the need to improve safety in an automotive environment. The conventional method for lifting cars is time consuming and can be unsafe in many circumstances. A device that can rapidly lift and secure the rear/front end(s) of a vehicle without requiring the user to get underneath the chassis of the vehicle, will improve safety.

(c) Function Statement:

The powertrain system of this auto-jack is responsible for providing the necessary power to lift a vehicle in a reasonable amount of time. The hydraulic portion (hydro pump and cylinder) of the system will work together with the driveshaft in order to extend a cylinder/lever system to lift the vehicle.

(d) Design Requirements:

- (1) The powertrain system of this auto-jack must be capable of lifting a 5000lb vehicle.
- (2) The powertrain system of this auto-jack must lift the vehicle at a rate of 1in/second.
- (3) The powertrain system of this auto-jack must have a vertical motion range from 4in (fully collapsed jack/open cylinder) to 35in (fully open jack/closed cylinder).
- (4) The automatic locking safety pin of this auto-jack must be capable of supporting a 5000lb load independently.
- (5) The powertrain system of this auto-jack must operate with no more than 3 gallons of hydraulic fluid.
- (6) The powertrain system of this auto-jack must weigh less than 60lbs.

(e) Engineering Merit:

The safety, capability, and efficiency of the AutoJack's powertrain is the overall focus for this project. The key factors driving the success of this design is the safety of the user, ease of operation, and lifting functionality. The hydraulic system is responsible for providing the necessary power to lift the applied load (the weight of the vehicle), which was determined and set to a maximum of 5000lbs. This specific maximum load was determined by researching car, truck, and SUV chassis configurations and weight distributions. These specifications were sourced from a variety of both domestic and foreign auto manufactures. In addition, the hydraulic system is also responsible for providing the range of motion needed to lift the vehicle to a maximum of 35inches off the ground. This specific height was determined by researching and field-testing for comfort.

Engineering merit was utilized in order to determine the size/dimensions of the hydraulic power unit, hydraulic cylinder, cylinder cross rods, cylinder clevis joints, cylinder pins, hydraulic lines, and the necessary hardware to mount the listed components. Force, pressure, normal stress, shear stress, fluid flow rate, and deflection equations were used to determine and select the proper equipment. This included appropriately sizing the power unit (pump flow and fluid capacity), hydraulic cylinder (working pressure and stroke length), cross rod diameter (deflection at center), cylinder clevis wall thickness (stress in double shear), cylinder pins (point of shear failure), and hydraulic lines (cross sectional area for necessary flow rate). It is also important to note that the financial cost of these materials is the primary limiter for the overall span of the project.

(f) Scope of this effort:

The scope of this effort will include the electric and hydraulic powertrain system responsible for providing the necessary power to safely lift the vehicle. This powertrain system consists of an electric/hydraulic "power unit", hydraulic cylinder, cylinder cross rods, cylinder clevis joints, cylinder pins, hydraulic lines, and the necessary hardware to mount the components of the powertrain.

(g) Success Criteria:

The success of this project can be measured/determined by testing to see if the auto-jack effectively and safely lifts the vehicle. Success depends on the final performance of the AutoJack safely lifting the test vehicle within our set design requirements.

(2) DESIGN AND ANALYSES

(a) Approach:

The design of the AutoJack was conceived after noticing the number of injuries and fatalities related to the improper lifting (jacking) and supporting of automobiles during mechanical maintenance. When servicing vehicles, mechanics frequently use standard claw/prong jack stands to secure the lifted vehicle. Since these standard jack stands rely on a mere 2inch² of contact surface area with the vehicle, there is an opportunity for the vehicle to shift, slide, and slip off of the stand. This creates a life-threatening situation for the mechanic underneath the

vehicle. In addition, the process for installing standard jack stands has proven to be time consuming. In a profession such as auto-repair where time is money, anytime taken to lift the vehicle and prepare it for service is essentially lost time, and therefore, lost money. The approach of the AutoJack design was entirely focused on the safety of lifting a vehicle. Safety was improved by creating an automated (hydraulically powered) system that doesn't require the user to maneuver under the vehicle to jack the vehicle or position jack stands. In doing so, the design has removed the operator from a potentially hazardous environment, maximizing safety. The frame design of the AutoJack features has a jack-to-vehicle contact area of 4 square feet, a massive safety increase from conventional jack stands.

(b) Design Description:

The AutoJack design consist of a 1020 steel square stock frame, 1020 steel square stock link arms jointed with 1020 steel dowel pins. In addition, two 1020 steel cross rods span the width of the frame and run through each set of link arms. A dual acting hydraulic cylinder is mounted on these cross rods and can be considered pinned between the two sets of link arms. The hydraulic cylinder is a dual acting cylinder, meaning that it is capable of providing force during both the extension and retraction stroke. An electric-hydraulic power unit (electric motor and hydro pump) provides fluid flow to the cylinder. The design utilizes the pulling force generated by the hydraulic cylinders retraction stroke in order to "pull" the cross arms and the connected link arms together. This scissor-like motion forces the upper frame to rise, ultimately lifting the vehicle. The range of motion (angle) that the link arms operate in, allow the Autojack to have a greater vertical motion range than it does horizontal. This means that the design is incredibly efficient, since a relatively small cylinder can provide a large amount of lift. A hand sketch of the AutoJack is pictured below for reference.

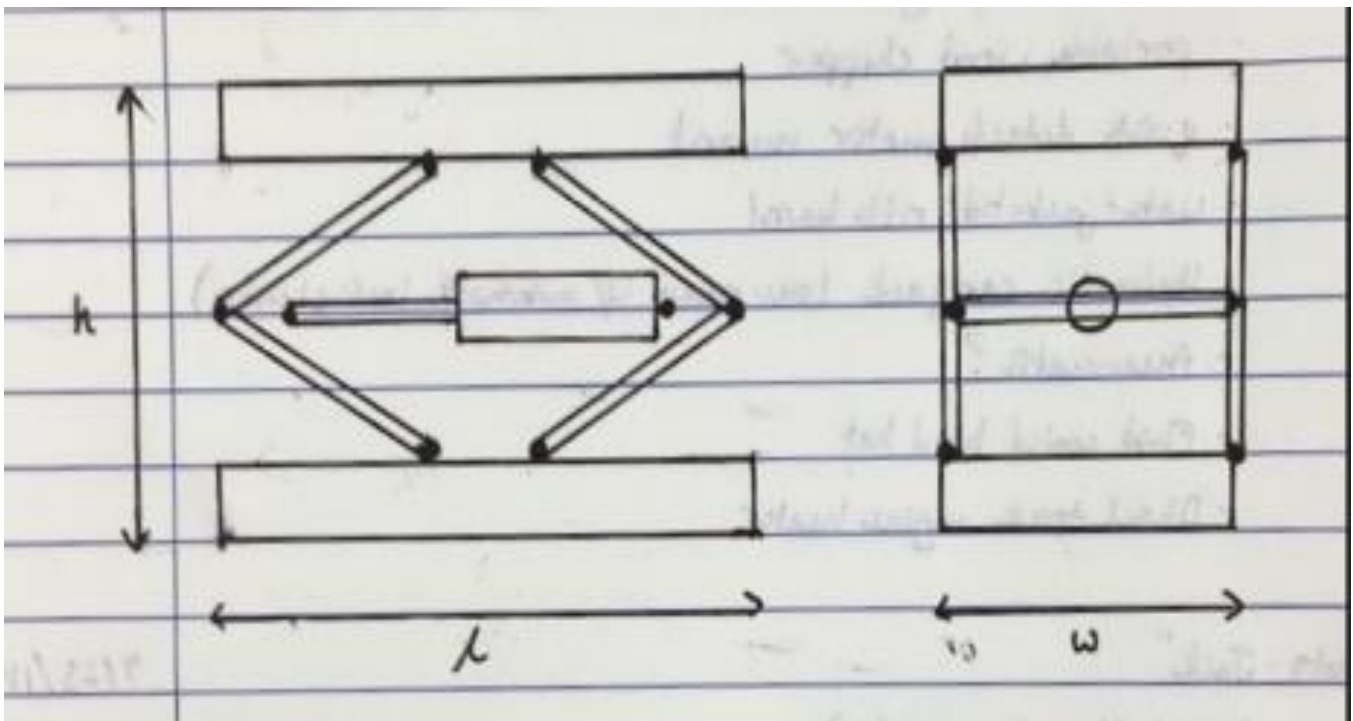

(c) Benchmark:

Another device that was developed to address this problem was the Safe-Jack Gator Jack, part number: #88M-SJGA0403 (Link: <https://safejacks.com/products/safe-jack-gator-jacks>). While this jack does in fact safely lift the vehicle, there are some major drawbacks. This device is only capable of lifting one corner of a vehicle at a time, it is expensive (\$1239.00), and it has no locking safety features. A more efficient, safer (dual safety), cheaper, and equally as user-friendly device is needed. The Safe-Jack Gator Jack is pictured below for reference.



(d) Performance Predictions:

Since the AutoJack utilizes a square-stock, rectangular frame design, it is predicted that this device will be substantially cheaper to manufacture than the Safe-Jack Gator Jack. In addition, the AutoJack will have significantly more jack-to-vehicle contact area. This will create a safer working environment. Furthermore, the AutoJack will also be capable of lifting the entire rear/front axle of a vehicle a full 35 inches off of the ground. In comparison, the Safe-Jack Gator Jack is only capable of lifting the vehicle one corner of the vehicle 18.25 inches off of the ground. It is important to note that the design of The Safe-Jack Gator Jack has the same critical flaw as that of standard or conventional jack stands; the contact area that the vehicle rests on is a mere 4in^2 . As stated previously, this creates a hazardous situation. The design of the AutoJack creates a jack-to-vehicle contact area of 4ft^2 . With this contact area, the lifted vehicle will always remain steady and secure even if the vehicle is leaned on, bumped, or impacted.

(e) Description of Analyses:

The powertrain analysis consists of 12 individual RADD engineering sheets. It begins by solving for the working pressure and piston stroke of the hydraulic cylinder given the 5000lb load and desired lift height. It then moves into the sizing of the hydraulic power unit; electric motor, fluid pump, and fluid reservoir given the cylinder requirements previously determined. Afterwards, the hydraulic lines, cylinder clevis joints, cylinder cross rods, and cylinder pins can be appropriately sized through further stress analysis. Each analysis follows proper engineering format; “Given, Find, Assume, Method, Answer, and Tolerance” and is labeled A-(1-12). Each analysis also follows and satisfies RADD guidelines; “Requirement, Analysis, Design, and Documentation”.

During the Winter Quarter: Construction Phase of the project, adjustments and modifications were made to the design of the AutoJack. Some of these changes altered the structural design of the lift system. Due to this, certain parts of the project had to be re-worked, re-analyzed, and/or ultimately re-designed. Two of the analyses effected were “Analysis A-11: Hydraulic Cylinder Clevis Pin Sizing Analysis” and “Analysis A-12: Frame/Cylinder Cross Rod Deflection Analysis – Winter Quarter”. These analyses have been labeled with “– Winter Quarter” or “- WQ” to signify the second set of revisions that took place during the Construction Phase.

The raw analyses can be found in “Appendix A” of this report. The description of each analysis can be found in point “(g) Analyses” of the “(2) DESIGN AND ANALYSES” section of this report.

(f) Scope of Testing and Evaluation:

The overall scope of testing and evaluation will consist of the success of the powertrain system. Success depends on the final performance of the AutoJack safely lifting the test vehicle within our set design requirements. Testing the Autojack with a test vehicle and recording the results will determine this success of the project. Furthermore, the ability for each component of the powertrain to perform its specified duty will serve as success indicators. The overall success can be evaluated by the final and overall performance and capability of the AutoJack.

(g) Analyses (Appendix A):

Green Sheet A-1 RADD: “Hydraulic Cylinder Force and Pressure Analysis”

- **Requirement (G & F):** Analysis A-1 was performed to address the design requirement of the powertrain lifting a 5000lb load. The goal here was to calculate the necessary dimensions for the hydraulic cylinder and then source the next available standard size.
- **Analysis (S):** In order to appropriately size the hydraulic cylinder for this specific situation, the bore diameter, rod diameter, working pressure and stroke length had to be

calculated. These values were cross-referenced with NorTrac's product catalog in order to confirm that the results were well under the working limit and therefore the design could be considered safe.

- **Design (A & T):** Analysis A-1 revealed that this design calls for a hydraulic cylinder with a 2in bore diameter, 1.125in rod diameter, a working pressure of at least 2350psi, and a minimum stroke length of 18in. It is important to remember that the cylinder effectively lifts the load directly with the connected link arms translating its horizontal motion into vertical motion. This can be treated as two separate 2500lb "pulls" or one 5000lb "pull" opposite to the fixed end of the cylinder.
- **Documentation:** Please see Appendix A, Analysis A-1 for this specific engineering analysis. Please see Appendix B, Drawing B-1 and B-2 for the corresponding engineering drawings.

Green Sheet A-2 RADD: "Hydraulic Cylinder Speed/Flow Rate Analysis"

- **Requirement (G & F):** Analysis A-2 was performed to address the design requirement of the powertrain lifting the desired load at a maximum rate of 1in/s. The goal here was to calculate the necessary flow rate for the specified hydraulic cylinder and then use this information to select and source the next available standard size hydraulic power unit.
- **Analysis (S):** In order to appropriately size the hydraulic power unit for this application, the effective piston area of the double acting cylinder had to be considered. In addition, the desired speed of 1in/s was set as the upper speed limit in when performing these calculations.
- **Design (A & T):** Analysis A-2 revealed that this design calls for a hydraulic power unit that can flow 0.6GPM. It is important to note that this flow rate is only required when the jack is opening and lifting the vehicle. When the jack is closing and lowering the vehicle the effective piston area is reduced and therefore requires a greater flow rate of 0.82GPM to move at the same 1in/s.
- **Documentation:** Please see Appendix A, Analysis A-2 for this specific engineering analysis. Please see Appendix B, Drawing B-1 and B-2 for the corresponding engineering drawings.

Green Sheet A-3 RADD: "Hydraulic Cylinder Clevis Pin Sizing Analysis"

- 1) **Requirement (G & F):** Analysis A-3 was performed to address the design requirement of the powertrain lifting the desired load using two clevis pins. The goal here was to calculate and ensure that the provided ½ inch clevis pins could withstand the shear stress of the lifting load. The figures used here also incorporate and account for a generous safety factor.

- 2) **Analysis (S):** In order to appropriately size the hydraulic cylinder clevis pins for this specific application, the pulling force exerted on the pin during the retraction stroke of the cylinder had to be considered. In addition, due to the geometry of the clevis joint, these pins were considered to be in “double shear” when performing these calculations.
- 3) **Design (A & T):** Analysis A-3 revealed that this design will indeed safely operate using the standard issue ½ inch clevis pins. It is important to note that since each pin is in “double shear”, they only experience a maximum moment of 625lb-in and a shear stress of approximately 6,400psi. Even after incorporating a generous safety factor of 1.5, this shear value (9,600psi) is well under the shear limit of each pin. This design can be considered safe.
- 4) **Documentation:** Please see Appendix A, Analysis A-3 for this specific engineering analysis. Please see Appendix B, Drawing B-4 for the corresponding engineering drawing.

Green Sheet A-4 RADD: “Frame/Cylinder Cross Rod Deflection Analysis”

- 1) **Requirement (G & F):** Analysis A-4 was performed as a secondary analysis in order to address the design requirement of the powertrain lifting a 5000lb load. The goal here was to calculate and ensure that the ½ inch diameter, 10inch cross rods could withstand the pulling force generated during the retraction stroke of the cylinder. The figures used here also incorporate and account for a generous safety factor.
- 2) **Analysis (S):** In order to appropriately size the hydraulic cylinder cross rods for this specific application, the pulling force exerted on the pin during the retraction stroke of the cylinder had to be considered. In addition, due to the mounting location of the hydraulic cylinder, the maximum shear and moment had to be considered when performing these calculations.
- 3) **Design (A & T):** Analysis A-4 revealed that this design will indeed safely operate using a 10inch long, ½ inch diameter cross rod. It is important to note that since the hydraulic cylinder is mounted between and at the center of these cross rods, the rods will experience a maximum shear stress of 2500lbs and a maximum moment of 7,500lb-in. Even after incorporating a generous safety factor of 1.5, the maximum deflection of each cross rod at its center will be 0.056inches. Therefore, this design can be considered safe.
- 4) **Documentation:** Please see Appendix A, Analysis A-4 for this specific engineering analysis. Please see Appendix B, Drawing B-5 for the corresponding engineering drawing.

Green Sheet A-5 RADD: “Hydraulic Line Selection Analysis”

- (1) **Requirement (G & F):** Analysis A-5 was performed to address the design requirement of the powertrain lifting the desired load at a maximum rate of 1in/s. The goal here was calculate the necessary dimensions of the hydraulic fluid lines responsible for flowing fluid throughout the components of the hydraulic circuit. These results were used to select and source the next available standard size hydraulic lines.
- (2) **Analysis (S):** In order to appropriately size the hydraulic lines for this specific application, the provided flow rate (from power unit) and desired velocity (requirement) had to be considered. The lift speed of 1in/s was set as the upper speed limit in when performing these calculations.
- (3) **Design (A & T):** Analysis A-5 revealed that this design calls for hydraulic hose/line with a nominal diameter of 0.78inch. Since 1.0inch is relatively expensive, 0.75inch line will be used in this hydraulic circuit with a negligible loss in lift rate. It is important to note that this flow rate is only required when the jack is opening and lifting the vehicle. Since the lifting rate is the only concern in this analysis, the lowering rate will be neglected.
- (4) **Documentation:** Please see Appendix A, Analysis A-5 for this specific engineering analysis. Please see Appendix B, Drawing B-2 and B-6 for the corresponding engineering drawings.

Green Sheet A-6 RADD: “Powertrain (Unit) System Analysis”

- (1) **Requirement (G & F):** Analysis A-6 was performed analyzing the overall powertrain system in order to address the design requirements of the powertrain lifting a 5000lb load at a rate of 1in/s. The goal here was to calculate and ensure that the two major components in the hydraulic circuit; the power unit and cylinder would operate properly together. The figures used here also incorporate and account for up/down sizing due to part availability.
- (2) **Analysis (S):** In order to ensure that this hydraulic circuit was indeed fully functional, calculated results from Analyses A-1 and A-2 were utilized. Furthermore, fluid pressure, stroke length, and cylinder velocity figures were calculated and ran against NorTrac spec sheets in order to confirm that the working numbers of each component were under the safety limit.
- (3) **Design (A & T):** Analysis A-6 revealed that this design will have a real time operating pressure of 1,600psi (< 3,000psi = safe), a cylinder stroke of 18inches, and cylinder velocity of 1.84in/s (> 1in/s requirement = safe). It is important to note that these working numbers were checked against the NorTrac hydraulic catalog. In doing so, common size part numbers could be documented; #992206 (cylinder) and #473933 (power unit).

- (4) **Documentation:** Please see Appendix A, Analysis A-6 for this specific engineering analysis. Please see Appendix B, Drawing B-2, B-6, and B-7 for the corresponding engineering drawings.

Green Sheet A-7 RADD: “Hydraulic Cylinder Fitment, Clearance, and Motion Analysis”

1. **Requirement (G & F):** Analysis A-7 was performed to address the design requirement of the powertrain system having a vertical motion range from 4in (fully collapsed jack/open cylinder) to 35in (fully open jack/closed cylinder). The goal here was to take the upper and lower frame constraints and calculate potential cylinder size and stroke combinations that could satisfy the design requirements. These results were used to select and source the closest available standard size hydraulic cylinder.
2. **Analysis (S):** In order to appropriately size the upper frame, lower frame, and hydraulic cylinder for these specific requirements, the total length, working length, and maximum link arm length had to be considered. In addition, due to the mounting location of the hydraulic cylinder, the maximum and minimum height of the jack was a major concern.
3. **Design (A & T):** Analysis A-7 revealed that the 4ft x 1ft frame combined with a 28.5inch closed (center-center) cylinder will satisfy all of the set requirements. It is important to note that with the jack closed/cylinder open the jack has a total height of 4inches and the cylinder has a total length of 45inches. With the jack open/cylinder closed the jack has a total height of 34.9inches and the cylinder has a total length of 28.5inches. Given the requirements, this design is satisfactory.
4. **Documentation:** Please see Appendix A, Analysis A-7 for this specific engineering analysis. Please see Appendix B, Drawing B-2, B-6, and B-7 for the corresponding engineering drawings.

Green Sheet A-8 RADD: “Hydraulic System (Fail-Safe) Pin Stress Analysis”

1. **Requirement (G & F):** Analysis A-8 was performed in order to address the design requirement of the automated safety pin being capable of supporting the 5000lb load independently. The goal here was to calculate and ensure that the 4inch long, ½ inch diameter safety pin could withstand the ultimate shear load applied by the weight of the 5000lb vehicle. The figures used here also incorporate and account for a generous safety factor.
2. **Analysis (S):** In order to ensure that the safety pin could support the given load, the force exerted on the pin during the hypothetical failure of the cylinder had to be considered. In addition, due to the geometry of the pin lock, the maximum shear load and maximum bending moment that the pin would experience in this situation were critical to obtaining valid results.

3. **Design (A & T):** Analysis A-8 revealed that the 4inch long, ½ inch diameter safety pin was capable of supporting the 5000lb load independently. It is important to note that since this design utilizes a pin that auto-locks, only half of the pin (2inches of length) will experience the shear load. There was a maximum shear force of 5000lbs, a maximum moment of 5000lb-in, and a maximum shear stress value of approximately 25.4ksi. Even after incorporating a generous safety factor of 1.5, this shear value (38.1ksi) is well under the shear limit of the safety pin. This design can be considered safe.
4. **Documentation:** Please see Appendix A, Analysis A-8 for this specific engineering analysis. Please see Appendix B, Drawing B-8 for the corresponding engineering drawing.

Green Sheet A-9 RADD: “Hydraulic System Fluid Volume Analysis”

- (1) **Requirement (G & F):** Analysis A-9 was performed in order to address two design requirements; the powertrain must operate with no more than 3 gallons of hydraulic fluid and that the powertrain system must weigh under 70lbs. The goal here was to calculate and ensure that full fluid volume needed to operate the hydraulic circuit remained under the weight limit. The figures used here also incorporate and account for a generous safety factor.
- (2) **Analysis (S):** In order to ensure that the working volume and weight were under the set requirements, the hydraulic circuit was considered to be full of fluid and its cylinder fully extended (larger effective area). In addition, due to the geometry of the circuit, the lengths of the working hydraulic lines were assumed to be the longest possible in order to obtain the most accurate results.
- (3) **Design (A & T):** Analysis A-9 revealed that the powertrain was capable of operating with fewer than 3 gallons of hydraulic fluid. It is important to note that since this design utilizes a double acting cylinder, there must be enough free storage available for the fluid that the piston rod displaces during the retraction stroke. When completely full, the hydraulic circuit will operate with approximately 250in³. In order to leave room for fluid displacement, the working fluid will be reduced to 200in³ (<231in³ = 1 gallon). Doing so will leave adequate room in the 173in³ fluid reservoir. This design can be considered sustaining.
- (4) **Documentation:** Please see Appendix A, Analysis A-9 for this specific engineering analysis. Please see Appendix B, Drawing B-2 for the corresponding engineering drawing.

Green Sheet A-10 RADD: “Powertrain System Total Weight Analysis”

1. **Requirement (G & F):** Analysis A-10 was performed in order to address the design requirement of the powertrain system weighing less than 70lbs. The goal here was to

calculate and ensure that the hydraulic/electric equipment remain under the desired weight limit, since they will be combined with a 48lb frame. The figures used here account for all system weight, including hydraulic lines and fluid.

2. **Analysis (S):** In order to ensure that the working weight of the powertrain was under the required 70lbs, the hydraulic circuit was considered to be full of fluid and its cylinder fully extended (larger effective area). In addition, due to the geometry of the circuit, the lengths of the working hydraulic lines were assumed to be the longest possible in order to obtain the most forgiving results. The weight of each component in the circuit was either calculated or found (in the NorTrac catalog) and then summed to find the total working weight.
3. **Design (A & T):** Analysis A-10 revealed that the work-ready powertrain would weigh in at 69.16lbs. It is important to note that the hydraulic power unit; electric motor, hydraulic pump, and fluid reservoir consumed the majority of the system weight limit. The hydraulic circuit contains a 24.55lb cylinder, 2.5lb line A, 2.5lb line B, 32.0lb power unit, and 7.61lb of fluid. In order to leave room for fluid displacement, the working fluid will be reduced to 200in³ (<231in³ = 1 gallon). Doing so will leave adequate room in the 173in³ fluid reservoir and reduce the overall system weight.
4. **Documentation:** Please see Appendix A, Analysis A-10 for this specific engineering analysis. Please see Appendix B, Drawing B-6 for the corresponding engineering drawing.

Green Sheet A-11 RADD: “Hydraulic Cylinder Clevis Pin Sizing Analysis” - WQ

1. **Requirement (G & F):** Analysis A-11 was performed to re-address the design requirement of the powertrain lifting the desired load using two clevis pins. The goal here was to re-calculate and ensure that smaller, 0.4inch clevis pins could withstand the same shear stress of the lifting load. Again, the figures used here also incorporate and account for a generous safety factor. The purpose for re-sizing the clevis pins was to reduce overall cost and resolve fitment issues.
2. **Analysis (S):** Again, in order to appropriately size the hydraulic cylinder clevis pins for this specific application, the pulling force exerted on the pin during the retraction stroke of the cylinder had to be considered. In addition, due to the geometry of the clevis joint, these pins were considered to be in “double shear” when performing these calculations.
3. **Design (A & T):** Analysis A-11 revealed that this design will indeed safely operate using the reduced diameter 0.4 inch clevis pins. It is important to note that since each pin is in “double shear”, they only experience a maximum moment of 625lb-in and a shear stress of approximately 9,950psi. Even after incorporating a generous safety factor of 1.5, this shear value (14,920psi) is well under the shear limit of each pin. This design can once again be considered safe.

4. **Documentation:** Please see Appendix A, Analysis A-11 for this specific engineering analysis. Please see Appendix B, Drawing B-4 for the corresponding engineering drawing.

Green Sheet A-12 RADD: “Frame/Cylinder Cross Rod Deflection Analysis” – WQ

1. **Requirement (G & F):** Analysis A-12 was performed as a secondary analysis in order to address the design requirement of the powertrain lifting a 5000lb load. The goal here was to re-calculate and ensure that smaller diameter (0.4inch), 10inch cross rods could withstand the same pulling force generated during the retraction stroke of the cylinder. The figures used here also incorporate and account for a generous safety factor. The purpose for re-sizing the cross rods was to reduce overall cost and resolve fitment issues.
2. **Analysis (S):** In order to appropriately size the hydraulic cylinder cross rods for this specific application, the pulling force exerted on the pin during the retraction stroke of the cylinder had to be considered. In addition, due to the mounting location of the hydraulic cylinder, the maximum shear and moment had to be considered when performing these calculations.
3. **Design (A & T):** Analysis A-4 revealed that this design will indeed safely operate using a 10inch long, ½ inch diameter cross rod. It is important to note that since the hydraulic cylinder is mounted between and at the center of these cross rods, the rods will experience a maximum shear stress of 2500lbs and a maximum moment of 7,500lb-in. Even after incorporating a generous safety factor of 1.5, the maximum deflection of each cross rod at its center will be 0.056inches. Therefore, this design can be considered safe.
4. **Documentation:** Please see Appendix A, Analysis A-12 for this specific engineering analysis. Please see Appendix B, Drawing B-5 for the corresponding engineering drawing.

(h) Parts of Device:

The powertrain system of the AutoJack consists of seven major components; an electric/hydraulic “power unit”, hydraulic cylinder, two cylinder cross rods, two cylinder clevis joints, two cylinder pins, two hydraulic lines, and the necessary hardware to mount the components of the powertrain together.

(i) Device Assembly:

The powertrain system will be pre-assembled, tested, and then installed into the fully extended frame of the AutoJack. Please see “APPENDIX E” for a complete and detailed assembly process.

(j) Tolerances:

The powertrain components of the AutoJack will be manufactured to the standards of the NorTrac Hydraulic Company. The frame components of the AutoJack will be manufactured in house with ANSI Y14.5 GD&T tolerances.

(k) Safety Factors:

Since the AutoJack will be lifting a 5000lb object nearly 3ft off of the ground, a generous safety factor must be incorporated into the design of both the powertrain and frame. Using reference material and considering the hazards of operation, a safety factor of 1.5 has been selected for both the components of the powertrain and frame.

(3) METHODS AND CONSTRUCTION

(a) Description:

The design of the AutoJack's powertrain was conceived after researching hazard reduction. The goal here was to completely remove the user from the vehicle lifting/securing process, and thereby, removing the hazard. A power source that can smoothly deliver the necessary power to lift a vehicle in the set requirements was needed. After researching and using an engineering decision matrix, hydraulic technology became the obvious choice. The analyses above show the theoretical efficiency of the powertrain. However, the manufacturing and construction process of the device remains to be defined. The section below will discuss the phases of the construction process, how these phases will be completed, and how each component of the design will be manufactured and/or purchased, and then assembled. Financially, the goal is to manufacture and assemble all possible parts from the resources provided by Central Washington University.

1. Hydraulic Power Unit: Construction

The power unit is a critical component of the AutoJack that is responsible for converting electrical energy into mechanical energy, or in other words, creating fluid flow. This sub-device must be purchased, since its design is a project in itself. Several analyses (reference "APPENDIX A") have been performed to determine the necessary requirements that the power unit must fulfill. Using these requirements as a checklist, the appropriate power unit was located and purchased from the NorTrac product catalog.

2. Hydraulic Cylinder: Construction

The hydraulic cylinder is another critical component of the AutoJack. It is responsible for translating fluid flow into liner motion. This sub-device must be purchased, since its design is a project in itself. Several analyses (reference “APPENDIX A”) have been performed to determine the necessary requirements that the hydraulic cylinder must fulfil. Using these requirements as a checklist, the appropriate cylinder was located and purchased from the NorTrac product catalog.

3. Cylinder Cross Rods: Construction

The cylinder cross rods are another critical component of the AutoJack. They are composed of ½ inch diameter, AISI 1020 steel round stock. The raw round stock will be purchased from Metal Supermarkets in Kent, WA. It will then be mounted in a vice and cut to the desired 10inch length using a table saw. The ends of each cross rod will then be faced on the lathe and deburred using the bench grinder. The Bridgeport End Mill, drill guide, and hole jig will then be used to correctly place the necessary cotter pin holes.

4. Cylinder Clevis Joints: Construction

The clevis joints of the cylinder are another critical component of the AutoJack. A total of ten clevis joints must be purchased, since it is significantly more cost effective and time efficient to purchase the relatively cheap clevis joints rather than milling each bracket by hand. Several analyses (reference “APPENDIX A”) have been performed to determine the necessary stresses that these clevis joints must withstand. Using these requirements as a checklist, the appropriate clevis joint was located and purchased from the Metal Supermarkets (Kent, WA) catalog.

5. Cylinder Pins: Construction

The cylinder pins are another critical component of the AutoJack. They are composed of ½ inch diameter, AISI 1020 steel round stock. The raw round stock will be purchased from Metal Supermarkets in Kent, WA. It will then be mounted in a vice and cut to the desired 4inch length using a table saw. The ends of each cross rod will then be faced on the lathe and deburred using the bench grinder. The Bridgeport End Mill, drill guide, and hole jig will then be used to correctly place the necessary cotter pin holes.

6. Hydraulic Lines: Construction

The hydraulic lines are another critical component of the AutoJack. They are responsible for transporting flowing fluid throughout the components of the hydraulic circuit. These parts must be purchased since the tools for construction are simply unavailable. Several analyses (reference “APPENDIX A”) have been performed to determine the necessary requirements that the hydraulic lines must fulfil. Using these requirements as a checklist, the appropriate line kit was located and purchased from the NorTrac product catalog.

7. Hydraulic Fluid: Construction

The hydraulic fluid is another critical component of the AutoJack. It is the fluid that allows the AutoJack and all of its components to function. This must be purchased since the tools for construction are simply unavailable. Several analyses (reference “APPENDIX A”) have been performed to determine the necessary requirements that the hydraulic fluid must fulfil. Using these requirements as a checklist, the appropriate fluid type and amount was located and purchased from the NorTrac product catalog.

(b) Drawing Tree:

The AutoJack drawing tree is divided into two sections of assembly; the powertrain assembly and the frame assembly. The powertrain assembly is composed of 5 branches indicating the drawing I’Ds for each branch, the drawing tree/I’Ds and the drawings (B-1 through B-8) for the AutoJack can be found in “APPENDIX B.”

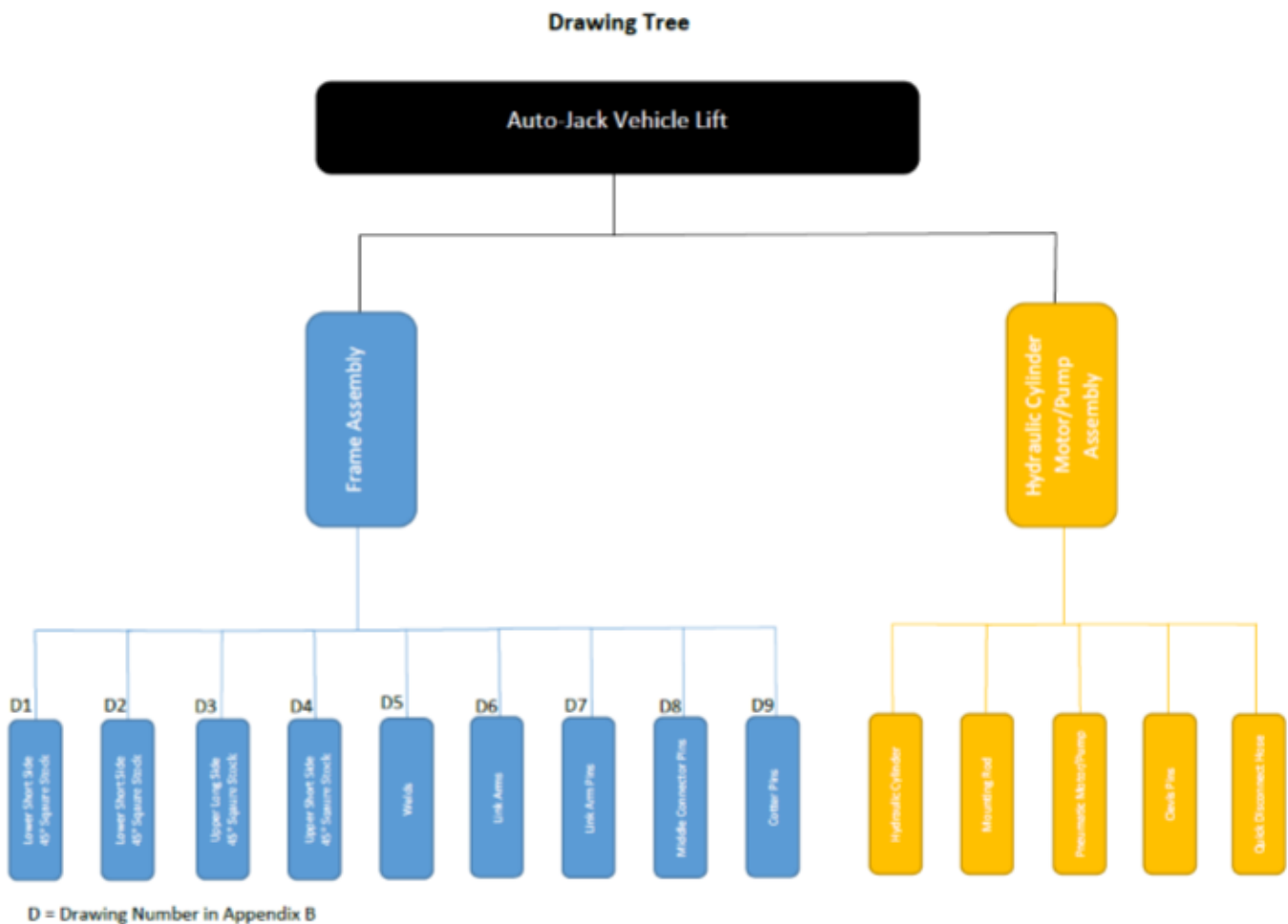

(c) Parts List and Labels:

Please see “APPENDIX C” for a complete Excel spreadsheet containing the AutoJack powertrain parts list, labels, and budget.

(d) Manufacturing Issues:

Potential manufacturing issues include finding/designing a safe and reliable drill guide and hole jig. Since drill bits tend to “walk” when drilling holes on a rounded surface, all safety precautions must be taken.

(e) Discussion of Assembly:

The AutoJack is composed of thirty-six separate parts and three subassemblies. The assembly of the AutoJack’s powertrain will follow that of the Gantt chart (“APPENDIX E”). After purchased material has arrived, the cylinder cross rods and pins will be manufactured immediately. The complete hydraulic circuit will then be pre-assembled outside of the AutoJack frame to ensure proper operation and motion. Finally, after both the powertrain and frame have been tested independently, they will be assembled together as discussed in the “Design Description”. The final assembly of the AutoJack has been pictured below for reference.

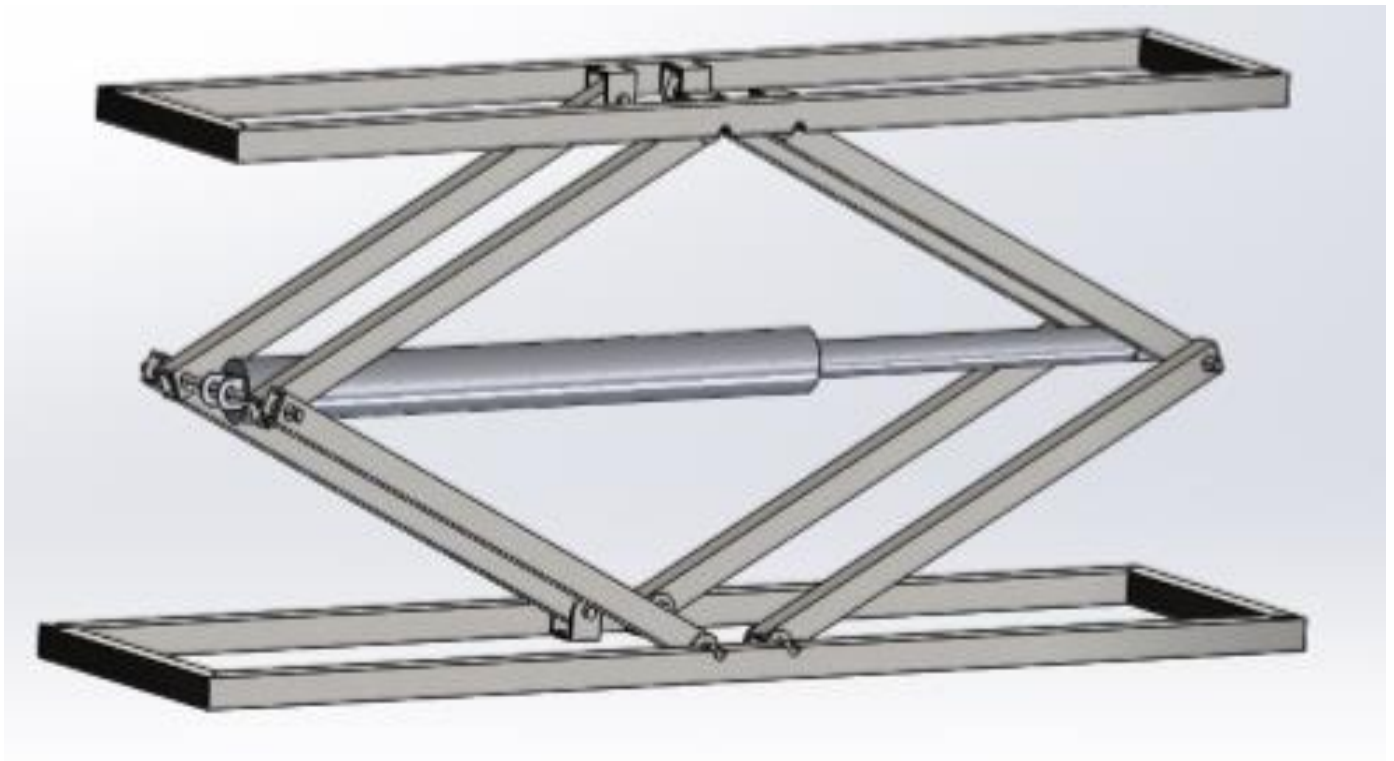

(f) M/C01:

Description of AutoJack – Powertrain System Cross Rod(s): The cylinder cross rods are a critical component of the AutoJack. They are composed of ½ inch diameter, AISI 1020 cold rolled steel round stock. The raw round stock was purchased from Metal Supermarkets in Kent, WA. The raw material was mounted in a vice and a roughing cut of 12.25inches was taken using a table saw. Afterwards, the section was mounted in a three-jaw lathe, and the ends of the cross rod were faced down 0.125inches, bringing the rods overall length down to 12.0inches +/- 0.005in. The ends of the rod were then chamfered 45 degrees with a depth of 0.05inches and finally deburred using a bench grinder/wire brush. Layout, a scribe, and drill press were then used to correctly locate and create the (2) 9/64inch diameter cotter pin holes. This process was then repeated for the second cross rod.

Manufacturing issues/modifications: There were two manufacturing issues when producing this part. Firstly, when facing the ends of each raw (12.25inch) rod on the lathe, they began to deflect and chatter due to the run out length. This chatter caused the finish quality of each rod end to be poor. Looking ahead, this would cause poor (or impossible) fitment and clearance with the other pinned parts of the AutoJack. The second issue when producing each cross rod was encountered when attempting to drill the cotter pin holes. Since the rod is of cylindrical geometry, the small diameter drill-bit wanted to walk off of the work piece, preventing a hole from being created.

Methods used to resolve issues: In order to resolve these manufacturing issues, Mathew Burvee was sought out for his machining experience and wisdom. For the rod chatter, Mr. Burvee suggested that center-drill at each end of the cross rod (on the lathe) in order to create a secondary mounting location on the work piece when facing and turning. This solution resolved the rods deflection and chatter issues when working on the lathe. For the drill-bit walking, Mr. Burvee provided a drill guide/hole jig that was mounted to the drill press. This stabilized the walking bit and allowed it to create the necessary cotter pin holes.

(g) M/C02:

Description of AutoJack – Powertrain System “Link Arm Insert” Part(s): The link arm inserts are another critical component of the AutoJack. They are composed of two separate sub-parts: the “LAI peg” and “LAI sleeve”. For this M/C02, manufacturing details regarding the “LAI sleeve” will be discussed. The sleeves (16) are made from AISI 1020 CR, 1” tube. The raw material was purchased from Metal Supermarkets in Kent, WA. The raw material (24in) was mounted in a vice and a roughing cut of 1.25inches was taken using a table saw. Afterwards, the section was mounted in a three-jaw lathe, and each end of the sleeve was faced down 0.125inches, bringing the sleeves overall length down to 1.00inch +/- 0.003in. Then, each end of the sleeve was chamfered 45 degrees to a depth of 0.05inches. Finally, the fully machined part was de-burred using a bench grinder/wire brush. This process was then repeated a total of 16 times in order to produce 16 fully machined LAI sleeves.

Manufacturing issues/modifications: There were two manufacturing issues when producing this part. Firstly, when rough-cutting each sleeve off of the raw material, the saw blade had un-

desired horizontal wobble from being worn. This caused each sleeve to come out with a different length, ranging from 1.10in – 1.40in. This was only discovered once all 16 sleeves had been rough cut and were re-measured. Looking ahead, this would cause poor (or impossible) fitment and clearance with the other pinned parts of the AutoJack.

The second issue when producing each LAI sleeve was encountered when attempting to assemble the completed sleeves with the other components of the AutoJack. When designed, the sleeve was intended to have an inner diameter of 0.50inches. Due to the nature of “drawn over mandrel” manufacturing, the produced ID was actually closer to 0.45inches. Looking ahead, this would prevent fitment with the other pinned parts of the AutoJack.

Methods used to resolve issues: In order to resolve these manufacturing issues, extra out-of-class time was allotted to the project and additional care was taken to correct and ensure the quality of each part. For the inconsistent rough cutting of the sleeves, each sleeve was carefully re-measured and then machined down to the desired 1.0inch length by hand, and one at a time. Since the initial plan was to utilize an automated machining program (that assumes the starting length of all parts to be uniform), this change added significant time to the production of these parts. However, the end result was 16 high quality, 1.00inch +/- 0.003in LAI sleeve parts. For the out of spec ID of each sleeve, Mathew Burvee was sought out for his machining experience and wisdom. Mr. Burvee suggested using a ½” reamer bit to remove the excess material and create a true ½” hole. This worked perfectly, and the reamed sleeves fit their mating components perfectly. These manufacturing issues have been fully resolved, and the AutoJack project remains on schedule.

(4) TESTING METHOD

(a) Introduction:

The overall success of the AutoJack design can be determined by testing to see if the AutoJack actually lifts the given test vehicle. However, to measure this success, a success criterion rubric will be utilized during testing. By doing so, the performance of the AutoJack can be quantified as it will either meet or fall short of each design requirement.

(b) Method/Approach/Test Description:

1. Hydraulic Cylinder Power Test:

This test will ensure that the hydraulic cylinder and power unit are functioning properly and that they provide the necessary power to lift the 5000lb load. This test will be conducted in the hydraulic lab by assembling the complete hydraulic circuit outside of the frame, mounting the cylinder in a clamp jig, and pushing a 5000lb slab. Obviously, the cylinder must move the slab in order to be considered successful in this test.

2. Hydraulic Cylinder Speed Test:

This test will ensure that the hydraulic cylinder and power unit are functioning properly and are capable of moving the applied load at a rate of 1in/s. This test will be conducted in the hydraulic lab by assembling the complete hydraulic circuit outside of the frame, mounting the cylinder in a clamp jig, and pushing a 5000lb slab. The cylinder must move the slab at a maximum rate of 1in/s (using a tape measure and stopwatch) in order to be considered successful in this test.

3. Total Collapsed Height Test:

This test will ensure that the hydraulic cylinder is functioning properly and has the necessary stroke to fully collapse the AutoJack frame. This test will be conducted in the hydraulic lab by assembling the complete AutoJack and fully extending the cylinder. With the cylinder fully extended, the total height of the AutoJack must be 4 inches or under (measured with a tape measure) in order to be considered successful in this test.

4. Total Expanded Height Test:

This test will ensure that the hydraulic cylinder is functioning properly and has the necessary stroke to fully expand the AutoJack frame. This test will be conducted in the hydraulic lab by assembling the complete AutoJack and fully extending the cylinder. With the cylinder fully retracted, the total height of the AutoJack must be 35 inches (measured with a tape measure) in order to be considered successful in this test.

5. Cross Rod Deflection Testing:

This test will ensure that the theoretical calculated deflection of each cross rod is accurate to the real world data. This will ensure that the cross rods do not fail in sure, bending, or fracture during the lifting process. This test will be conducted in the Materials Lab using the Tenuis Olsen machine. Each cross rod will be mounted at its ends, simulating frame support. A 2500lb load will then be applied and the results will be measured and recorded in order to determine the cross rods deflection at max loading. The cross rods must deflect minimally or less than the theoretical values in order to be considered successful in this test.

6. Total Powertrain Weight Test:

This test will ensure that the completed powertrain has remained under the maximum weight limit of 70lbs. This test will be conducted in the Materials Lab using a scale accurate to the nearest pound. The powertrain system will simply be placed on the scale and the weight reading will be recorded. Obviously, the powertrain system must weight less than 70lbs in order to be considered successful in this test.

(c) TEST

AutoJack - Powertrain System: Testing

In total, there will be six mechanical powertrain tests. These tests will determine whether or not the powertrain system of the AutoJack has successfully met the set design requirements. These tests consist of a “Hydraulic Cylinder Power Test”, “Hydraulic Cylinder Speed Test”, “Total Collapsed Height Test”, “Total Expanded Height Test”, “Cross Rod Deflection Test”, and a “Total Powertrain Weight Test”. However, these tests will be conducted at the same time as the other mechanical frame tests.

In order to evaluate the overall functionality and performance of the AutoJack, all of the mechanical (powertrain + frame) must be considered. Two of the most crucial features that the total system must be tested for are “lift stability” and “resistance to compressive loads”.

In order to test the lift stability of the AutoJack, the link arm system will be raised by charging the hydraulic cylinder with compressed air. As the system rises, pre-determined side loads (pushing and pulling) will be applied to the ends of the upper frame. Measurements will be taken during the applications of each load. If the system has less than 1inch of play in all directions (x, y, and z), the AutoJack lifting process may be considered stable.

In order to test the AutoJack’s resistance to compressive loads, the entire powertrain + frame assembly will be placed within a confined area of the power lab. The lower frame of the device will be secured to the ground using fasteners and clamps. Then, slabs of different weights will be added to the upper frame. With each increasing load increment, measurements will be taken at each critical point along the system. This will continue until either a 5000lb load has been achieved, or there is a system failure. In order to be considered successful in this test, the AutoJack must have less than a ¼ inch of material deflection at any point. If so, the AutoJack design may be considered resistant to compressive loads (vehicle).

(d) TES01

Powertrain System Test 1: “Hydraulic Speed Test – Loaded”

One of the biggest safety advantages that the AutoJack’s powertrain design offers over other conventional jacking methods is its smooth, steady, and fluid lifting operation. This characteristic has been achieved through the use of hydraulics and fluid power. The AutoJack’s hydraulic circuit is composed of several components, with the primary parts being the dual-acting cylinder and DC power unit. These components work together in order to transmit power through fluid and into linear motion. In order to minimize safety risks, this linear motion must occur at a steady and consistent rate. Therefore, it is critical that the hydraulic system operates as it was designed to.

To ensure that the system was operating at consistent speeds, a test was in order. The test consisted of mounting the hydraulic system in a device jig and running the circuit with various

applied loads. Please see the “Test Plan” located in Appendix I for full documentation of this test. During evaluation, time (s) and distance (in) measurements were taken. Afterwards, these values could be used to calculate linear rate (in/s) values. This test will ensure that the cylinder and power unit are functioning correctly and are capable of meeting design requirement 3; moving the maximum applied load at a rate of 1in/s.

After Test 1 had been completed and average calculations had been made, the results could be analyzed. On average, the AutoJack’s hydraulic system was capable of traveling the 12in set distance in 2.76 seconds regardless of the applied load amount (tested 100lbs-500lbs). This means that the AutoJack’s powertrain transmits enough power to lift the load at 4.35 in/s on average. Compared to the lifting design requirement of 1 in/s minimum, the powertrain system has surpassed all relevant expectations and excelled in lift speed. Therefore, the AutoJack can be considered successful in Test 1: “Hydraulic Speed Test – Loaded.” The testing and evaluation phase of this device will continue as outlined in the project Gantt chart schedule located in APPENDIX E. Like the results from Test 1, future results will be appropriately documented with photographs and tabulated data and then added to APPENDIX G of this report.

(e) TES02

Powertrain System Test 4: “Lifting Applied Load”

Another advantage that the AutoJack’s powertrain design offers over other conventional jacking methods is its vertical lifting capabilities. Despite its relatively compact and lightweight design, the AutoJack is capable of lifting nearly 3-tons of direct load. This capability has been achieved through the use of hydraulics and fluid power. The primary parts of the AutoJack’s hydraulic circuit are the dual-acting cylinder and DC power unit. These components work together in order to transmit fluid power into horizontal motion. This horizontal motion is then translated into a vertical motion, through a mechanical linkage system. Once contact with the above vehicle has been made, this vertical motion is the motion that lifts the car. Therefore, it is critical that the hydraulic system operates as it was designed to.

To ensure that the system was operating with correct/safe force and pressure values, a test was in order. The test consisted of placing the complete AutoJack device underneath a test vehicle, and actuating and raising the system. An in-line pressure gauge, machinists square, and stopwatch were used to check for proper function. Please see the Test section located in Appendix I for full documentation of this test. During evaluation, several maximum pressure (psi) measurements were taken. Afterwards, these values could be used to calculate the average maximum pressure (psi). If the AutoJack ceased to lift at any point, the “stall pressure” was recorded. These stall pressure values were also averaged to find the average stall pressure. By using the average stall pressure value, fluid-dynamic equations were used to solve for the average “stall weight”. This test will ensure that the cylinder and power unit are functioning correctly and are capable of meeting design requirement 1: the powertrain system of the AutoJack must be capable of lifting a 5000lb vehicle.

After Test 4 had been completed and average calculations had been made, the results could be analyzed. With a 3599lb test vehicle, the AutoJack's hydraulic system operated at an average pressure of 1710psi. This means that proportionally, the AutoJack's powertrain transmits enough power to lift a 5000lb load with an operating pressure of approximately 2910psi. Compared to the 5000lb lifting design requirement, the powertrain system has surpassed all relevant expectations and excelled in lifting capability. Therefore, the AutoJack can be considered successful in Test 4: "Lifting Applied Load." The testing and evaluation phase of this device will continue as outlined in the project Gantt chart schedule located in APPENDIX E. Like the results from Test 4, future results will be appropriately documented with photographs and tabulated data and then added to APPENDIX G of this report.

(5) BUDGET/SCHEDULE/PROJECT MANAGEMENT

(a) Proposed Budget:

1. Discuss Part Suppliers and Substantive Costs:

The powertrain components of the AutoJack will be purchased through two main part suppliers; NorTrac Hydraulics (online) and Metal Supermarket (Kent, WA).

2. Determine Labor/Outsourcing Rates and Estimate Costs:

The components of the AutoJack will be obtained, manufactured, and assembled by the two-man team designing the device. Therefore, it is not necessary to evaluate external labor or outsourcing rates.

3. Estimate Total Project Cost:

The estimated total project cost of the AutoJack's powertrain system is \$476.46.

4. Funding Source(s):

The AutoJack project is being funded by the two-man team designing the device. The project has no external funding, sponsors, or donators.

(b) Proposed Schedule:

The schedule for this project has been organized and illustrated with an Excel Gantt chart. This Gantt chart can be found in "Appendix E". The Gantt chart is divided into three distinct sections which include; "Design & Analysis" (Fall Quarter), "Methods & Construction" (Winter Quarter), and "Testing" (Spring Quarter). The "Design & Analysis" section of this project is presented in the form of a proposal. This proposal outlines the entire project from start to finish

and contains all of the proper engineering documentation necessary to support the project. The next section, “Methods & Construction”, focuses on the physical construction of the AutoJack design generated in section one. The construction process will include all drawing trees, parts lists, budget lists, and any manufacturing issues that arise during the construction of the AutoJack. The third and final section, “Testing”, features the actual testing of the final device. This entails the description, methods, and testing processes used to determine the success of the project.

Perhaps the largest factor that will impact the schedule of this project, will be obtaining the required material within the desired time frame. Since several of the hydraulic components are specialized for this design, it make take a greater amount of time to source them. If this transaction takes more time than anticipated, it may affect the overall schedule of the project.

Milestones for the AutoJack project include:

1. Complete Project Proposal by December 4th, 2018 - COMPLETED
2. Complete Project Construction by March 6th, 2019 - COMPLETED
3. Complete and present a successful AutoJack device by June 5th, 2019 – IN PROGRESS

(c) Project Management

(1) Human Resources:

1. **CWU’s Dr. Craig Johnson** – Provided guidance throughout the design phase of this project.
- 2.
3. **CWU’s Charles Pringle** –Provided guidance throughout the design phase of this project.
4. **CWU’s Jeunghwan Choi** –Provided guidance throughout the design phase of this project.
5. **CWU’s Tedman Bramble** – Provided access to the Hogue Machine Shop. Supervised and provided guidance during the manufacturing phase of the project.
6. **CWU’s Mattew Burvee** - Provided access to the Hogue Machine Shop. Supervised and provided guidance during the manufacturing phase of the project.
7. **CWU’s Daryl Fuhrman** - Provided access to the Hogue Welding Shop and Hydraulics Lab. Supervised and provided guidance during the manufacturing phase of the project.

(2) Physical Resources:

1. CWU Hogue Machine Shop
2. CWU Hogue Hydraulic Lab

3. CWU Hogue Welding Lab
4. CWU Hogue Materials Lab
5. CWU Hogue CAD Lab
6. Family Owned Fabrication Garage located in Seattle, WA.

(3) Soft Resources:

1. Dassault Systemes Solidworks
2. Microsoft Excel
3. Microsoft Word

(4) Financial Resources:

The AutoJack project is being funded by the two-man team designing the device. The project has no external funding, sponsors, or donators.

(d) SCH01:

Manufacturing Schedule Issues/Changes:

There were two manufacturing issues when producing the cross rod part(s). Firstly, when facing the ends of each rod on the lathe, they began to deflect and chatter due to the run out length. Looking ahead, this would likely cause poor (or impossible) fitment and clearance with the other pinned parts of the AutoJack. The second issue when producing each cross rod was encountered when attempting to drill the cotter pin holes. Since the rod is of cylindrical geometry, the small diameter drill-bit wanted to walk off of the work piece, preventing a hole from being created.

These manufacturing issues delayed the completion of the cross rod part(s) by a total of two man-hours (one class period). Looking ahead, this delay would push the entire production schedule forward an entire workday. Given our projected construction timeline, this was unacceptable. Therefore, an additional overtime (out-of-class) workday was allotted to the part production schedule. This has been reflected in the project Gantt chart.

Methods used to resolve issues:

In order to resolve these scheduling issues, additional out-of-class work time was allotted to complete the machining process of each rod. During this time, Mathew Burvee was sought out for his machining experience and wisdom. For the rod chatter, Mr. Burvee suggested that center-drill at each end of the cross rod (on the lathe) in order to create a secondary mounting location or the work piece when facing and turning. This solution resolved the rods deflection and chatter issues when working on the lathe. For the drill-bit walking, Mr. Burvee provided a drill guide/hole jig that was mounted to the drill press. This stabilized the walking bit and allowed it to create the necessary cotter pin holes.

By completing the cross rod part(s) machining out-of-class, the production time allotted for this portion of the AutoJack project has been followed. Therefore, the construction timeline has been corrected and the progress of the project remains in line with the Gantt chart.

(e) BUDG – B:

Manufacturing Budget - cost: As of 2/5/19, all necessary raw materials and purchased parts have been obtained and stored in the CWU shop room. The total cost of the AutoJack project has been calculated to be \$571.68. Since the project was budgeted to \$750.00, we remain well under the spending limit.

Manufacturing Budget - cost change due to change in design: As of 2/5/19 and 3/7/19, there have been two changes in the Autojack system design in order to reduce the overall cost of the project. The first change was sourcing the Hydraulic Power Unit from a cheaper retailer. Initially, the Power Unit was projected to cost \$445.50, but after some additional searching, the same unit was found on sale for \$218.59 from a different NorTrac part distributor. Purchasing this part from this distributor saved \$226.91. The second change design change was replacing the \$8.59/ea purchased swing bolts with manufactured link arm inserts (\$3.51/ea). Since there were 16 of these parts replaced, the savings totaled up to \$81.28. These two project design changes saved a total of \$308.19.

Manufacturing Budget - cost due to errors/mistakes: As of 2/5/19 and 3/7/19, there have been no errors or mistakes during the construction of the AutoJack. Therefore, the cost of the project has not been effect by any production errors/mistakes.

Manufacturing Budget - actual cost: As of 2/5/19 and 3/7/19, the actual cost of the AutoJack project, including raw material, purchased parts, and tax, has been calculated to be \$571.68.

Manufacturing Budget - methods used to resolve issues: Budget issues have been resolved by sourcing raw material and purchased parts from cheaper/discount retailers.

(f) SCHED

Testing Schedule Issues/Changes:

There were two testing issues when testing the AutoJack's powertrain. During Test 1, the cylinder-clamp jigs would come out of perpendicular alignment and travel out at random degrees of motion. Therefore, each traveled distance was completely random and likewise, so was the measured elapsed times. This testing issue rendered the results inaccurate and invalid. The second testing issue occurred during Test 4. Due to the complexity of the AutoJacks hydraulic system, where the only available location for the pressure test gauge was in a weld-on port underneath the cylinder. This proved to be problematic when the scissor system could not fully collapse without crushing the test gauge. At this point, no results could be obtained.

These testing issues delayed the completion of the testing phase by a total of 6 man-hours or three class periods. Looking ahead, this delay would push the entire Gantt schedule forward by 3 entire workdays. Given our projected testing timeline, this was unacceptable. Therefore, three additional overtime (out-of-class) workdays were allotted to the device-testing schedule. This has been reflected in the project Gantt chart.

Methods used to resolve issues:

In order to resolve these scheduling issues, additional out-of-class work time was allotted to complete each test and the testing process. During this time, Mathew Burvee was sought out for his mechanical experience and wisdom. For the Test 1 cylinder misalignment issue, the clamp jigs and connecting clevis pins were disassembled and taken back to the machine shop for a tighter boring/turning operation. The powertrain system was then reassembled with the tighter tolerance parts. This allowed the jigs, pins, and cylinder to fit together much tighter. This eliminated all system wobble and eliminated the room for misalignment. For the Test 4 gauge fitment issue, a 3/8in-1/4in 90° elbow fitting was installed on the cylinder port and the test gauge was re-installed on the new fitting. This modification allowed the test gauge to mount horizontally instead of vertically, which added nearly 3.5 inches of ground clearance. Test 4 was then conducted properly.

By correcting/completing Test 1 and 4 out-of-class, the testing phase that was originally allotted for this portion of the AutoJack project, has been followed. Therefore, the testing timeline has been corrected and the progress of the project remains in line with the engineering Gantt chart schedule.

(g) BUDG – C:

Testing Phase Budget - cost: As of 5/14/19, all necessary testing materials (purchased and manufactured) have been obtained and stored in the CWU senior project room. The total cost of the AutoJack project has been calculated to be \$992.68. Since the cumulative project was budgeted to \$1000.00, we remain under the spending limit.

Testing Phase Budget - cost change due to testing issues: As of 5/14/19, there have been two changes in the AutoJack testing phase in order to reduce the overall cost of the project. The first change and cost reduction was made during Test 1 when raw gear stock was required to stabilize the scissor system. Instead of purchasing \$110.99 gear stock from McMaster-Carr, custom 1020 gears were machined from the CWU machine shop scrap bin. This saved the project \$110.99. The second change during the testing phase was made during Test 4 when an in-line pressure gauge was required. This part was originally projected to cost \$48.93. However, by talking with Mr. Bramble, the gauge unit was sourced and loaned to the AutoJack project by CWU. This saved the project \$48.93. These two project-testing changes saved a total of \$159.92.

Testing Phase Budget - cost due to errors/mistakes: As of 5/14/19, there have been no errors or mistakes during the testing of the AutoJack. Therefore, the cost of the project has not been affected by any production errors/mistakes.

Testing Phase Budget - actual cost: As of 5/14/19, the actual cost of the AutoJack project, including raw material, purchased parts, custom machined parts, and tax, has been calculated to be \$992.68.

Testing Phase Budget - methods used to resolve issues: Budget issues have been resolved by sourcing testing material and raw part material from Central Washington University.

(6) DISCUSSION

1. Design Evolution/Performance Creep:

During the Fall design phase, the AutoJack has seen several iterations. Initially, the idea was to utilize an “X” frame and mount the hydraulic cylinder perpendicular to the cross of the “X” shaped link arms. However, this design quickly gave way since the link arm geometry would not allow for a decent vertical lift. The AutoJack was then redesigned into a 2ft x 2ft square, utilizing a scissor link arm system and a vertically mounted cylinder. This time around, fitment of the hydraulic system was a major problem. After several brainstorming sessions and decision matrix’s, the AutoJack design had evolved into the current 4ft x 1ft rectangular frame, “<>” link arm system, and horizontally mounted hydraulic cylinder powertrain.

2. Project Risk Analysis:

There is a significant amount of risk involved with the construction of the AutoJack. There are health and safety risks ranging from inhaling welding fumes, pinching inside the moving components of the device, and hydraulic fluid injection. Following the proper PPE procedures will help to minimize the present risks. In addition, having a trained, qualified, and authorized supervisor overseeing the construction and testing phases will reduce the risks of shop accidents. Being compliant with these safety standards minimize the chance for injury during the construction of the device. Since the design phase of the project was performed in the CAD lab, there was no health or safety risks. The “Risk Analysis Hazard Sheet” can be found in “APPENDIX J” of this engineering report.

3. Project Documentation:

Full project documentation can be found in the appendices of this proposal report. This documentation includes 12 engineering analyses, 8 engineering drawings, Gantt schedule, parts/budget lists, safety hazard forms, photographs of the project, and all relevant references. Please refer to the appendices of this engineering report for each section of documentation.

4. Next Phase:

The next phase of this project is the construction of the AutoJack device. This process will begin with submitting raw material orders to their respective manufacturers on January 3rd,

2019. Once the necessary materials and parts have arrived, the physical construction process described in the “(3) METHODS AND CONSTRUCTION” section will begin.

(e) DIS01 - B:

AutoJack - Powertrain System: “Cross Rod(s)” Part Manufacturing Discussion

Manufacturing Issues/Modifications:

The cylinder cross rods are a critical component of the AutoJack. They are composed of ½ inch diameter, AISI 1020 cold rolled steel round stock. These rods span the width of the AutoJack’s frame and serve as a common/shared attachment point for the link arm, clevis sleeve, and hydraulic cylinder clevis mounts. When the hydraulic cylinder is retracted, these cross rods are pulled together, which in turn, expand the scissor system and lift the vehicle.

There were two manufacturing issues when producing this part. Firstly, when facing the ends of each rod on the lathe, they began to deflect and chatter due to the run out length. This chatter caused the finish quality of each rod end to be poor. Looking ahead, this would likely cause poor (or impossible) fitment and clearance with the other pinned parts of the AutoJack. The second issue when producing each cross rod was encountered when attempting to drill the cotter pin holes. Since the rod is of cylindrical geometry, the small diameter drill-bit wanted to walk off of the work piece, preventing a hole from being created.

Methods used to resolve issues:

In order to resolve these manufacturing issues, Mathew Burvee was sought out for his machining experience and wisdom. For the rod chatter, Mr. Burvee suggested that center-drill at each end of the cross rod (on the lathe) in order to create a secondary mounting location on the work piece when facing and turning. This solution resolved the rods deflection and chatter issues when working on the lathe. For the drill-bit walking, Mr. Burvee provided a drill guide/hole jig that was mounted to the drill press. This stabilized the walking bit and allowed it to create the necessary cotter pin holes.

(f) DIS02 - B:

AutoJack - Powertrain System: “Link Arm Insert(s)” Manufacturing Discussion

Manufacturing Issues/Modifications:

The link arm inserts are a critical component of the AutoJack. They are composed of two separate sub-parts: the “LAI peg” and “LAI sleeve”. For this DIS02, manufacturing details regarding the “LAI sleeve” will be discussed. The sleeves (16) are made from AISI 1020 CR Steel, 1” tube. These link arm inserts are inserted into both ends of each link arm and are secured with 4 MIG weld beads. They serve as constrained pivot points for the AutoJack’s scissor lift system. When the hydraulic cylinder is retracted, the cross rods are pulled together, pivoting the link arms inwards towards each other. This motion expands the scissor system, raises the upper frame, and lifts the vehicle.

There were two manufacturing issues when producing this part. Firstly, when rough-cutting each sleeve off of the raw material, the saw blade had un-desired horizontal wobble from being worn. This caused each sleeve to come out with a different length, ranging from 1.10in – 1.40in. This was only discovered once all 16 sleeves had been rough cut and were re-measured. The second issue when producing each LAI sleeve was encountered when attempting to assemble the completed sleeves with the other components of the AutoJack. When designed, the sleeve was intended to have an inner diameter of 0.50inches. Due to the nature of “drawn over mandrel” manufacturing, the produced ID was actually closer to 0.45inches. Looking ahead, these issues would cause poor or impossible fitment and clearance with the other pinned parts of the AutoJack.

Methods used to resolve issues:

In order to resolve these manufacturing issues, extra out-of-class time was allotted to the project and additional care was taken to correct and ensure the quality of each part. For the inconsistent rough cutting of the sleeves, each sleeve was carefully re-measured and then machined down to the desired 1.0inch length by hand, one at a time. Since the initial plan was to utilize an automated machining program (that assumes the starting length of all parts to be uniform), this change added significant time to the production of these parts. However, the end result was 16 high quality, 1.00inch +/- 0.003in LAI parts.

(g) DIS01 - C:

AutoJack - Test 1: “Hydraulic Speed Test – Loaded” Discussion

Testing Issues/Modifications:

One of the biggest advantages that the AutoJack’s design offers over other conventional jacking methods is its self-actuated hydraulic system. This system enables the AutoJack to have a consistent and steady lifting operation. Therefore, in order to maximize safety, it is absolutely critical that the hydraulic system operates as it was designed to. To ensure that the system was operating at consistent speeds, a test was in order. The test consisted of mounting the hydraulic system in a device jig and running the circuit with various applied loads. During evaluation, time (s) and distance (in) measurements were taken. Afterwards, these values could be used to calculate linear rate (in/s) values.

There was one major issue when performing this test. Firstly, when providing power to the circuit, the cylinder-clamp jigs would come out of perpendicular alignment. This would cause the cylinder to extend out at an angle and travel farther than the pre set distance. Due to the additional traveling distance, each test trial required a greater time window. It is also important to note that the degree at which the jig setup would misalign itself was completely random. Therefore, each traveled distance was completely random and likewise, so was the measured elapsed times. Due to these reasons, this testing issue rendered the results inaccurate and invalid.

Methods used to resolve issues:

In order to resolve these testing issues, extra out-of-class time was allotted to the project and additional care was taken to correct and ensure testing success. For the cylinder misalignment issue, the clamp jigs and connecting clevis pins were disassembled and taken back to the machine shop for a boring/turning operation. Using the lathe, the jig holes were re-bored to accept a larger 1.0in diameter pin. Afterwards, the clevis pins were turned down to 0.975in diameter(s). The powertrain system was then reassembled with the fresh parts. These precisely machined parts allowed the jigs, pins, and cylinder to fit together much tighter. This eliminated all system wobble, and thereby eliminated the room for misalignment. Test 1 was then conducted properly. It was found that on average, the AutoJack's powertrain transmits enough power to lift the load at 4.35in/s. This has surpassed all relevant expectations and minimum lift speed requirements. Therefore, Test 1 and the AutoJack itself can be considered successful.

(h) DIS02 - C

AutoJack - Test 4: "Lifting Applied Load" Discussion

Testing Issues/Modifications:

Another big advantage that the AutoJack's powertrain design offers over other conventional jacking methods is its vertical lifting capabilities. This system enables the AutoJack to lift nearly 3-tons of direct load. In order to maximize performance, it is crucial that the hydraulic system operates as it was designed to. To ensure that the system was operating with correct/safe force and pressure values, a test was in order. The test consisted of placing the complete AutoJack device underneath a test vehicle, and actuating the system. During evaluation, distance (in) and pressure (psi) measurements were taken. Afterwards, these values could be averaged and used to calculate the operating pressure of the hydraulic circuit and the internal force within each frame member.

There was one major issue when performing this test. Due to the complexity of the hydraulic system, the only available location for the pressure test gauge was in a weld-on port underneath the cylinder. This proved to be problematic when the scissor system could not fully collapse without crushing the test gauge. This meant that the AutoJack would have to remain open an additional 6 inches, and therefore, would not fit underneath the selected test vehicle (2004 Honda CR-V SUV). At this point, Test 4 could not continue and no results could be obtained.

Methods used to resolve issues:

In order to resolve these testing issues, extra out-of-class time was allotted to the project and additional care was taken to correct and ensure testing success. In order to solve the pressure gauge fitment issue, two solutions were developed and implemented. Firstly, the pressure test gauge was removed from the cylinder. A 3/8in-1/4in 90° elbow fitting was then installed on the cylinder port. Afterwards, the test gauge could be re-installed to the new fitting. This modification allowed the test gauge to mount horizontally instead of vertically. This added nearly 3.5 inches of ground clearance, meaning that the AutoJack could now lower within 2.5 inches of the ground. The second solution to this testing issue was simply changing the

selected test vehicle (2001 Ford Ranger Pickup). Since the pickup truck sits higher than the SUV, the AutoJack could remain 2.5 inches open and still fit underneath the vehicle easier. Test 4 was then conducted properly. It was found that on average, the AutoJack's powertrain operates at 1710psi when lifting a 3599lb vehicle. This has surpassed all relevant expectations and operating pressure requirements. Therefore, Test 4 and the AutoJack itself can be considered successful.

(7) CONCLUSION

By the end of the design phase (Fall), the AutoJack powertrain had met all of the design requirements. Furthermore, the powertrain system exceeded the performance of the project benchmark. The final cost of the device totaled significantly under that of the benchmark. If time is available, the AutoJack will undergo aesthetic upgrades such as powder coating. The driving motivation behind this project was reducing risk and improving safety in the automotive workplace environment. The user free operation, jack-to-vehicle contact area, and stability of the AutoJack will allow the user to service a vehicle with a maximum level of safety. The AutoJack significantly reduces the safety risks present when lifting a vehicle into the air.

When comparing the AutoJack to the project benchmark, the amount of device/system improvement becomes clear; the AutoJack has a 500% increase in maximum load capacity, a 27% greater maximum lift capacity, a lift speed increase of 100% (2in/s to 4in/s), an operational time reduction of 30%, a jack-to-vehicle contact area (safety) increase of 14,400% (4in² to 4ft²), and a total cost reduction of 40%. The AutoJack is also more user-friendly than the benchmark, since the user is only required to slide the device under the vehicle. This device maximizes safety all while saving time and money.

The AutoJack also meets the parameters of a successful CWU MET senior project. First, there is a significant amount of engineering merit in the design of the AutoJack; force, pressure, shear stress, and deflection analysis, static and dynamic considerations, and mechanical design. Secondly, the cost and budgeting of this project is within reason and necessary resources are available. Third and finally, there is physical proof in the efficiency of the design and the teamwork and collaboration that made the project possible.

By the end of the construction phase (Winter), the AutoJack powertrain has met all of the design requirements. However, the powertrain system needs adjustments during the testing phase (Spring) in order to operate flawlessly. The final cost of the device has remained significantly under that of the benchmark device. The AutoJack will also undergo aesthetic upgrades such as powder coating over the course of the Spring Quarter. The driving motivation behind this project remains to be improving safety in the automotive workplace environment. The user free operation, jack-to-vehicle contact area, and stability of the AutoJack will allow the user to service a vehicle with a maximum level of safety. The AutoJack significantly reduces the safety risks present when lifting a vehicle into the air.

The AutoJack continues to meet the parameters of a successful CWU MET senior project. First, there is a significant amount of engineering merit in the design and re-design (the iteration process) of the AutoJack; force, pressure, shear stress, and deflection analysis, static and dynamic considerations, and mechanical design. Also, the cost and budgeting of this project remains realistic, and replicates that of a professional real-life situation. Finally, there is distinct physical proof in the efficiency of the design and the teamwork and collaboration that made the project possible. Therefore, the AutoJack project has continued to be a successful engineering senior project through Spring Quarter: Construction Phase.

(8) ACKNOWLEDGEMENTS

5. **Central Washington University** – Allowed MET students to access the CAD Lab, Machine Shop, Welding Shop, Hydraulics Lab and all of their resources.
6. **CWU’s Dr. Craig Johnson** – Provided guidance throughout the design phase of this project.
7. **CWU’s Charles Pringle** – Provided guidance throughout the design phase of this project.
8. **CWU’s Jeunghwan Choi** – Provided guidance throughout the design phase of this project.
9. **CWU’s Tedman Bramble** – Provided access to the Hogue Machine Shop. Supervised and provided guidance during the manufacturing phase of the project.
10. **CWU’s Mattew Burvee** - Provided access to the Hogue Machine Shop. Supervised and provided guidance during the manufacturing phase of the project.
11. **CWU’s Daryl Fuhrman** - Provided access to the Hogue Welding Shop and Hydraulics Lab. Supervised and provided guidance during the manufacturing phase of the project.
12. **Carl’s Powder Coating Service** - Provided professional powder coating service for the project during the manufacturing phase of the project.

(9) REFERENCES

1. Mott - *Machine Elements in Mechanical Design*, 6th edition.
2. Eaton - *Hydraulic Training Manual*, 5th edition.
3. NorTrac Hydraulic Supplier Product Catalog
(Link: https://www.northerntool.com/shop/tools/category_hydraulics+nortrac)

(10) APPENDIX A – ANALYSES

Analysis A-1: Hydraulic Cylinder Force and Pressure Analysis

A-1	10/30/18	MET489A	Tyce Vu	1/1
<p>AutoJack Powertrain Analysis : hydraulic cylinder force and pressure analysis</p> <p>Given: Design requirement (powertrain system must be capable of lifting a 5000lb load to a maximum height of 18")</p> <p>Find: necessary (+ SF) dimensions for the hydraulic cylinder using standard available sizes</p> <p>Assume: N/A</p> <p>Method: 1) sketch w/ FBD 2) determine l_c, l_r, and l_{unit} 3) determine required ϕ_c and ϕ_r (Formulas 1-2 and 1-4 from pages 16 and 17). 4) select cylinder model</p> <p>Solution:</p> <div style="display: flex; justify-content: space-around; align-items: flex-start;"> <div style="text-align: center;"> </div> <div style="font-size: small;"> <p>Note: Cylinder effectively lifts car directly w/ arms translating horizontal motion into vertical. Can be treated as two separate 25000 lb "pulls" or as one single 5000 lb "pull" from the opposite to "fixed" end of the cylinder.</p> <p>Note: Using Nortrac common size cylinder, part # 992206.</p> </div> </div> <div style="text-align: center; margin-top: 20px;"> </div> <p>Pressure:</p> $P = \frac{F}{A} \rightarrow P = \frac{F}{(A_p - A_r)} \rightarrow P = \frac{F}{\left(\frac{\pi}{4} \phi_p^2\right) - \left(\frac{\pi}{4} \phi_r^2\right)}$ $P = \frac{5000 \text{ lbs}}{\left(\frac{\pi}{4} (2 \text{ in})^2\right) - \left(\frac{\pi}{4} (1.125 \text{ in})^2\right)} \rightarrow P = 1328.21 \text{ psi} \quad \left(\begin{array}{l} \phi_c/r = 2 \text{ in} \\ \phi_r = 1.125 \text{ in} \end{array} \right)$ <p>Length, l:</p> $l_{unit} = 36 \text{ in} = l_c + l_r = 18 \text{ in} + 18 \text{ in} \quad \left(\begin{array}{l} l_c = 18 \text{ in} \quad l_{unit} = 36 \text{ in} \\ l_r = 18 \text{ in} \end{array} \right)$				

Analysis A-2: Hydraulic Cylinder Speed/Flow Rate Analysis

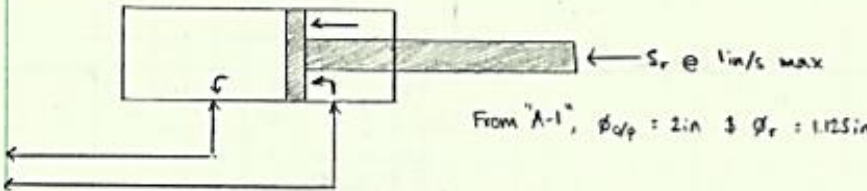
A-2	10/30/18	METV89A	Type No	1/1
<p>AutoJack Powertrain Analysis : hydraulic cylinder speed / flow rate analysis</p> <p>Given: Design requirement (powertrain system must be capable of lifting the vehicle / desired load at a maximum rate of 1in/s)</p> <p>Find: Necessary (+ SF) flow rate (\dot{Q}) for the hydraulic cylinder & size motor unit</p> <p>Assume: N/A</p> <p>Method: 1) sketch 2) solve for \dot{Q} (Formula 3-2, page. 159) Etc Hydraulic lift manual 3) use chart to select appropriate standard motor size</p> <p>Solution:</p>				
				
$\text{Flow (GPM)} = \frac{\text{Effective Piston Area (in}^2\text{)} \times \text{Speed (in/min)}}{2.31 \text{ in}^3/\text{gal}}$ $\dot{Q}_{req} = \frac{\left(\left(\frac{\pi}{4} d_p^2 \right) - \left(\frac{\pi}{4} d_r^2 \right) \right) (1 \text{ in/s}) (60 \text{ sec/min})}{2.31 \text{ in}^3/\text{gal}}$ $\dot{Q}_{req} = \frac{\left(\left(\frac{\pi}{4} (2 \text{ in})^2 \right) - \left(\frac{\pi}{4} (1.125 \text{ in})^2 \right) \right) (60 \text{ in/min})}{2.31 \text{ in}^3/\text{gal}}$ $\dot{Q}_{req} = 0.5578 \text{ GPM} \approx 0.56 \text{ GPM} = 0.60 \text{ GPM}$ $\dot{Q}_{req} = 0.6 \text{ GPM}$				
<p>Using standard size motor / power unit chart...</p>				

Analysis A-3: Hydraulic Cylinder Clevis Pin Sizing Analysis

A-3

10/30/18

MET489A

Tyler Vu

1/1

AutoJack Powertrain Analysis: hydraulic cylinder clevis pin sizing (shear stress)

Given: Design requirement and safety requirement (pin must withstand 2000lb + load w/SF)

Find: necessary pin size, ϕ for cylinder clevis joints

Assume: N/A

- Method:
- 1) sketch
 - 2) FED
 - 3) solve for reactions
 - 4) V/M diagram
 - 5) solve for ϕ_{min} (+SF)

Solution:

Note: Pin is in double shear due to clevis geometry.

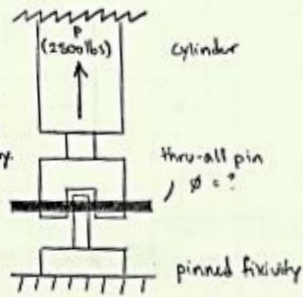

FED:

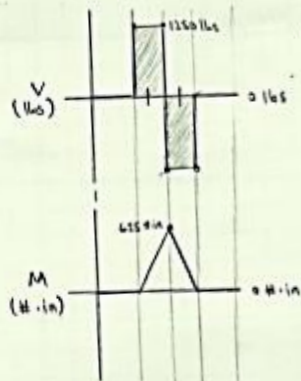
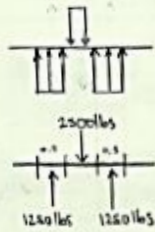

From V/M diagrams...

Max Shear Value, $V_{max} = 1250 \text{ lb}$
 Max moment value, $M_{max} = 625 \text{ in}$

Shear stress in pin (for double shear)

$$\tau_{pin} = \frac{2P}{\pi d^2}$$

$$\tau_{pin} = \frac{2(2500 \text{ lbs})}{\pi (0.5 \text{ in})^2} \quad \text{* try standard 0.5 in pin}$$

$$\tau_{pin} = 6366.19 \text{ psi}$$

Alternatively...

$$\tau_{pin} = \frac{V}{A}$$

$$\tau_{pin} = \frac{1250 \text{ lbs}}{\frac{\pi}{4} (0.5 \text{ in})^2}$$

$$\tau_{pin} = 6366.19 \text{ psi}$$

Analysis A-4: Frame/Cylinder Cross Rod Deflection Analysis

A-4

10/30/18

MET489A

Type W

1/1

AutoJack Powertrain Analysis: frame/cylinder cross rod deflection analysis

Given: AutoJack dimensions, properties for 1020 steel

Find: Deflection of $\phi = 0.5 \text{ in}$ @ $L = 12 \text{ in}$ & resize to required dimensions if necessary

Assume: N/A

- Method:
- 1) sketch (FV & RV)
 - 2) FBD
 - 3) solve for reactions
 - 4) solve for δ_r
 - 5) resize?

Solution:

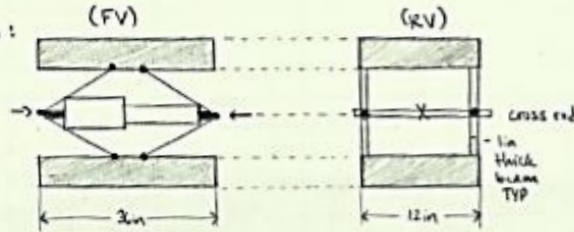

$$d = \frac{m}{v} \rightarrow m = dv$$

$$m = (0.281 \text{ lb/in}^3) \left(\frac{\pi}{4} (0.5 \text{ in})^2 (12 \text{ in}) \right)$$

$$m = 0.5576 \text{ lbs}$$

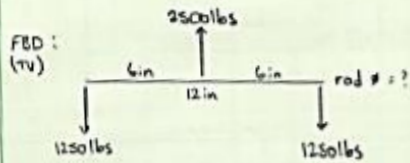

$$\delta_c = \frac{FL^3}{48EI} \quad \text{where } E = 200 \text{ GPa} \quad \text{and } I = \frac{1}{12} \pi d^4$$

$$\delta_c = \frac{(2500 \text{ lbs})(12 \text{ in})^3}{48(200 \text{ GPa}) \left(\frac{1}{12} \pi (0.5 \text{ in})^4 \right)}$$

$$\delta_c = 0.05604 \text{ inches}$$

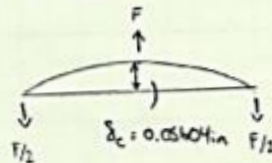
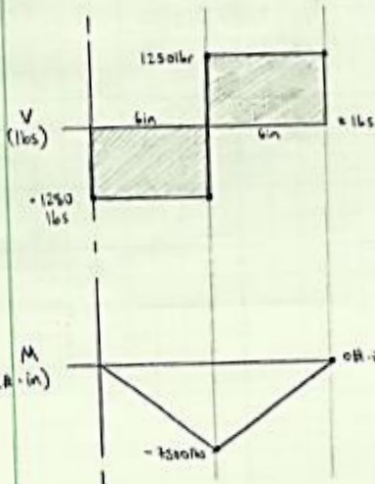

Analysis A-5: Hydraulic Line Selection Analysis

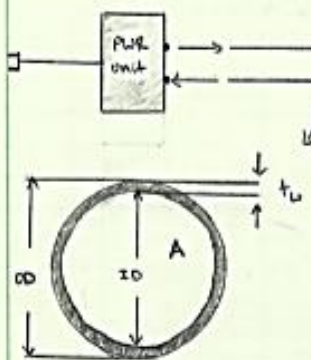
A-5	10/30/18	MET489A	Type W	1/1
<p>AutoJack Powertrain Analysis: hydraulic line selection</p> <p>Given: Design requirement (powertrain system must be capable of lifting the vehicle / desired load at a maximum rate of 1in/s)</p> <p>Find: Necessary (+SF) dimensions for the hydraulic fluid lines using standard available sizes.</p> <p>Assume: N/A</p> <p>Method: 1) sketch 2) solve for cross sectional area of line (A) (Formula) 3) solve for OD and Wt 4) use chart to select appropriate standard size</p> <p>Solution:</p> <div style="display: flex; align-items: flex-start;"> <div style="flex: 1;">  </div> <div style="flex: 2; padding-left: 20px;"> $\text{Area} = \frac{\text{GPM} \times 0.3208}{\text{Velocity (ft/s)}} \quad \text{where } \text{GPM} = 1.36 \text{ GPM}$ $\text{Area} = \frac{(0.6 \text{ GPM})(0.3208)}{(1/12 \text{ ft/s})}$ $\text{Area} = 2.3076 \text{ in}^2 \quad \text{where } A = \frac{\pi}{4} D^2$ </div> </div> <p style="margin-top: 20px;">Solving for nominal or ID:</p> $\frac{\pi}{4} D^2 = 0.4812 \rightarrow D = 0.7827 \text{ in} \approx \begin{cases} \#12 \text{ } 3/4 \text{ in hose} \\ \#16 \text{ } 1 \text{ in hose} \end{cases}$ <p>OD & Wt: Standard sizes & dimensions associated with nominal diameter</p> <p>Note: Please see attached chart for a complete hose & fitting selection process.</p>				

Analysis A-6: Powertrain (Unit) System Analysis

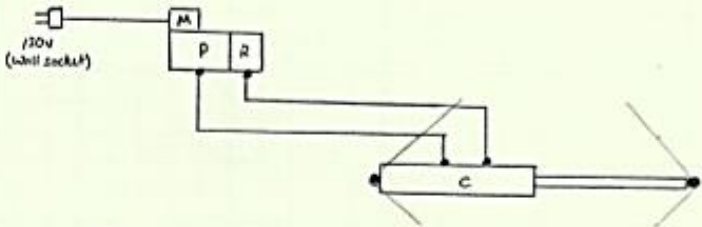
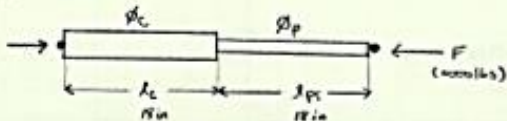
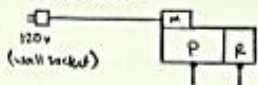
A-6	10/23/18	MET189A	Type Vu	1/2
"Autojack" - Powertrain System Analysis w/ RAO				
Given: Autojack design requirements (3000lb car load & lift rate of 1in/s)				
Find: appropriate sizing for hydraulic power unit and cylinder				
Assume: N/A				
Method: 1) sketch system (hydraulic circuit) 2) solve for required cylinder dimensions 3) solve for power unit specs 4) RAO				
Solution:				
				
Cylinder:				
				
NoTRe common size (18 in) Cylinder #92206:				
$d_c = 3in$ $d_p = 2in$ $P_{max} = 3000 \text{ psi rating}$				
$P = \frac{F}{A} = \frac{3000 \text{ lbs}}{\frac{\pi}{4} (2in)^2} = 1591.55 \text{ psi}$				
$P: 1591.55 \text{ psi} < 3000 \text{ psi rating} \checkmark$ $l_c = l_c + l_p = 36in = 18in + 18in \checkmark$				
Power Unit:				
				
NoTRe common size PWR unit # 47393:				
$V_{cyl} = \frac{Q_{pump}}{A_{cyl}} = \frac{5.795 \text{ in}^3/s}{\frac{\pi}{4} (2in)^2} = 1.858 \text{ in/s}$				
$v: 1.858 \text{ in/s} > 1 \text{ in/s requirement} \checkmark$				
$Capacity = 0.75 \text{ gal}$ $P \text{ Flow rate, } Q_p = 1.5 \text{ GPM} = 5.795 \text{ in}^3/s$ $M \text{ pur} = 2HP$ $M \text{ speed} = 3000 \text{ RPM}$ $M \text{ sigl} = 2.4cc$ $M \text{ amp} = 250 \text{ max Amps}$				

Analysis A-6 Continued: Powertrain (Unit) System Analysis

10/25/18	MET-454A	Type U ₆
<p>RADD:</p> <p>Requirement: Cylinder must lift a minimum of a 5000 lb load. Motor/pump PWR unit must meet demand of 1 in/s lift.</p> <p>Analysis: please see attached green sheet "1/2"</p> <p>Design: • Cylinder ($d_c = 3$ in, $l_c = 18$ in, $d_p = 2$ in, $l_p = 18$ in, $P = 1591.55$ psi (< 3000 psi max)) • PWR unit ($V_{cyl} = 1.838$ in/s (> 1 in/s req.))</p> <p>Documentation: please see attached green sheet "1/2"</p> <p>Answer: Cylinder: Nortrac # 992206 PWR unit: Nortrac # 47313</p> <p>Tolerance: N/A</p>		



Analysis A-7: Hydraulic Cylinder Fitment, Clearance, and Motion Analysis

A-7	11/2/18	MET489A	Tyce Vg	1/1
AutoJack Powertrain Analysis: hydraulic cylinder fitment, clearance, and motion analysis.				
Given: Design Requirement (powertrain system must have a vertical motion range from 4in (fully collapsed jack/open cylinder) to 35in (fully open jack/closed cylinder)).				
Find: necessary cylinder stroke and sizing (account for frame dimensions).				
Assume: N/A				
Method: 1) select desired/arbitrary values 2) sketch 3) dimension 4) solve for resulting l & h				
Solution:				
(4ft x 4ft)				
			$l_{total} = 48in$ $l_{working} = 45in$ $Link\ Arm\ l_{max} = 21.5in$ $\left\{ \begin{array}{l} J_{closed} / Cyl_{open} : Cyl\ l\ of\ 45in \\ J_{open} / Cyl_{closed} : cyl\ l\ of\ 28.5in \end{array} \right.$ $\left\{ \begin{array}{l} J_{closed}, h = 4in \\ J_{open}, h = (16.95)(2) + (0.5)(2) = 34.86in \end{array} \right.$	
J _{open} / Cyl _{closed} :		J _{closed} / Cyl _{open} :		

Analysis A-8: Hydraulic System (Fail-Safe) Pin Stress Analysis

A-8	11/2/18	MET489A	Tyce U	1/1
AutoJack Powertrain Analysis: hydraulic system fail-safe pin stress analysis				
Given: Design Requirement (the automated safety-pin of the jack must be capable of supporting a 5000lb load independently).				
Find: Necessary dimensions (ESF) for safety pin (0.5in standard?)				
Assume: Pin is placed where it will undergo direct shear w/ support along half the pin				
Method: 1) sketch 2) FBD w/ solve for reactions 3) V/M diagram 4) τ_{max}				
Solution:				
$\phi = 0.5in$			$L = 5000lb$ $L/in = 2500lb/in$ $\sum F_y = 0 = -5000lb + A_y \rightarrow A_y = 5000lb$ $\sum M_A = 0 = -5000lb(1in) + M_A \rightarrow M_A = 5000lb \cdot in$ $\sum F_x = 0 = 0 \rightarrow A_x = 0lb$	
			<p>From V/M diagram...</p> $V = 5000lb$ $M = 5000lb \cdot in$ $\tau = \frac{V}{A} = \frac{5000lb}{\frac{\pi}{4} (0.5in)^2} = 25464.79lb/in^2$ $\tau_{pin} = 25.4ksi \text{ (safe?)}$	

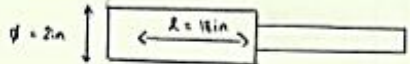
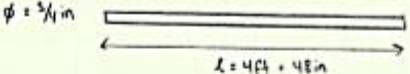
Analysis A-9: Hydraulic System Fluid Volume Analysis

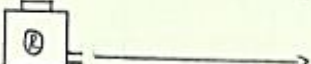
A-9	11/13/18	MET489A	Tyce W	1/1
<p>Autodesk Fountain Analysis: hydraulic system fluid volume analysis</p> <p>Given: Design requirement (pneumatic system must operate with no more than 3 gallons of hydraulic fluid & pneumatic system must weigh under 60 lbs).</p> <p>Find: necessary fluid volume to operate hydraulic circuit and remain under weight limit.</p> <p>Assume: Vial assumed a completely filled system w/ cylinder fully extended (large effective area).</p> <p>Method:</p> <ol style="list-style-type: none"> 1) sketch 2) determine V_{cyl}, V_{line1}, V_{line2}, V_{pump}, V_{res}, V_t 3) calculate total mass of working fluid / weight of working fluid / look up weight from manufacturer 4) adjust reservoir size if necessary <p>Solution:</p> <div style="display: flex; justify-content: space-between;"> <div style="width: 45%;">  <p>$\phi = 2 \text{ in}$</p> <p>$L = 18 \text{ in}$</p> </div> <div style="width: 50%;"> $V_{cyl_{max}} = \left(\frac{\pi}{4} D^2\right) (L) = \left(\frac{\pi}{4} (2 \text{ in})^2\right) (18 \text{ in}) = 56.55 \text{ in}^3$ $V_{cyl_{min}} = \left(\left(\frac{\pi}{4} A_1^2\right) - \left(\frac{\pi}{4} A_2^2\right)\right) (L) = \left(\left(\frac{\pi}{4} (2 \text{ in})^2\right) - \left(\frac{\pi}{4} (1.125 \text{ in})^2\right)\right) (18 \text{ in}) = 38.44 \text{ in}^3$ </div> </div> <div style="display: flex; justify-content: space-between; margin-top: 10px;"> <div style="width: 45%;">  <p>$\phi = 3/4 \text{ in}$</p> <p>$L = 4 \text{ ft} + 48 \text{ in}$</p> </div> <div style="width: 50%;"> $V_{line1} = \left(\frac{\pi}{4} D^2\right) (L) = \left(\frac{\pi}{4} (0.5 \text{ in})^2\right) (48 \text{ in}) = 9.42 \text{ in}^3$ $V_{line2} = \left(\frac{\pi}{4} D^2\right) (L) = \left(\frac{\pi}{4} (0.5 \text{ in})^2\right) (48 \text{ in}) = 9.42 \text{ in}^3$ </div> </div> <div style="display: flex; justify-content: space-between; margin-top: 10px;"> <div style="width: 45%;">  </div> <div style="width: 50%;"> $V_{pump} = 1.5 \text{ CFM} \text{ (given by Nortrac - neglect volume of fluid)}$ </div> </div> <div style="display: flex; justify-content: space-between; margin-top: 10px;"> <div style="width: 45%;">  </div> <div style="width: 50%;"> $V_{res} = 0.73 \text{ gal} = 173.25 \text{ in}^3 \text{ (given by Nortrac)}$ </div> </div> <div style="margin-top: 20px;"> $V_{total} = V_{cyl(max)} + V_{line1} + V_{line2} + V_{pump} + V_{res}$ $V_{total} = 56.55 \text{ in}^3 + 9.42 \text{ in}^3 + 9.42 \text{ in}^3 + 0 + 173.25 \text{ in}^3$ $V_{total} = 248.64 \text{ in}^3$ <p><i>Note:</i> This Vial assumes that system is full, therefore, room must be left in the reservoir for fluid head change. Use Vial for reference.</p> $V_{total(working)} = 200 \text{ in}^3 \text{ w/ } 173.25 \text{ in}^3 \text{ reservoir}$ $W_{fluid} = 1 \text{ gal @ } 7.61 \text{ lbs (given by Mobil from Nortrac)}$ </div>				

Analysis A-10: Powertrain System Total Weight Analysis

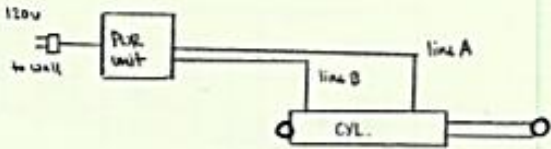
A-10	11/13/18	MET489A	Type V+	1/1
<p>AutoTask Powertrain Analysis: powertrain system total weight analysis</p> <p>Given: Design requirement (powertrain system must weigh less than 70 lbs).</p> <p>Find: Total weight of powertrain system.</p> <p>Assume: Provided weight data from manufacturers and Solidworks is accurate.</p> <p>Method:</p> <ol style="list-style-type: none"> 1) List components 2) calculate/list given weight for each component 3) Total system weight 4) Adjust/propose weight reduction methods <p>Solution:</p> <ul style="list-style-type: none"> • Hydraulic Cylinder (NorTrac 992206) → weight: 24.55 lbs • Hydraulic line A → weight: 2.5 lbs • Hydraulic line B → weight: 2.5 lbs • Hydraulic Power unit w/ fluid reservoir (NorTrac 49393) → weight: 32.0 lbs • Hydraulic fluid (Mobil 1) → weight: 7.61 lbs/gal <p>Total system weight, W_T:</p> $W_T = W_{cyl} + W_{lineA} + W_{lineB} + W_{powerunit} + W_{fluid}$ $W_T = 24.55 \text{ lbs} + 2.5 \text{ lbs} + 2.5 \text{ lbs} + 32.0 \text{ lbs} + 7.61 \text{ lbs}$ $W_T = 69.16 \text{ lbs} \quad (< 70 \text{ lbs})$ <p>Proposed methods for system weight reduction...</p> <ul style="list-style-type: none"> • Shorten working lines? • cut/weld/shorten cylinder? • size down power unit? • remove fluid from system? <div style="text-align: right;">  </div>				

Analysis A-11: Hydraulic Cylinder Clevis Pin Sizing Analysis – Winter Quarter

1/1

11/28/15 MET489A Type VI

AutoJack Powertrain Analysis: hydraulic cylinder clevis pin sizing (shear stress) - REDO

Given: Design Requirement and safety requirement (pin must withstand 2500lb + load w/SF)
Analysis A-3

Find: Shear stress in re-sized pin / σ for cylinder clevis joints

Assume: N/A

Method: 1) sketch
2) FBD
3) solve for reactions
4) V/M diagram
5) solve for τ in pin w/ new dimensions

Solution:

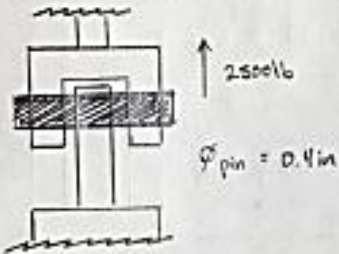

2500 lb

$d_{\text{pin}} = 0.4 \text{ in}$

FBD:



2500 lb

1250 lb 1250 lb

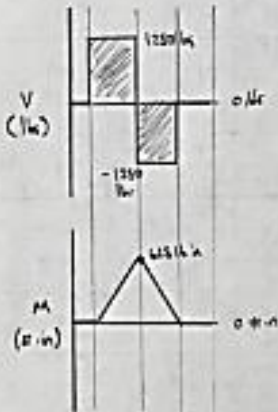

1250 lb

-1250 lb

625 lb-in

\hookrightarrow Max Shear: $V_{\text{max}} = 1250 \text{ lb}$
 \hookrightarrow Max Moment: $M_{\text{max}} = 625 \text{ lb-in}$
 \hookrightarrow Double Shear

Shear Stress in pin ...

$$\tau_{\text{pin}} = \frac{2P}{\pi d^2} = \frac{2(2500 \text{ lb})}{\pi (0.4 \text{ in})^2} = 9947.2 \text{ psi}$$

$$\tau_{\text{pin w/SF}} = \tau_{\text{pin}} \cdot SF = 9947.2 \text{ psi} \cdot 1.5 = 14,920.78 \text{ psi}$$

Analysis A-12: Frame/Cylinder Cross Rod Deflection Analysis – Winter Quarter

1/1

11/28/17 MET489A Tye W

AutoJack Poutreain Analysis: frame/cylinder cross rod deflection analysis - RFD

Given: AutoJack dimensions
 Properties for AISE 1020 Steel ($\rho = 0.284 \text{ lb/in}^3$, $E = 200 \text{ GPa}$)
 Analysis A-4

Find: Deflection of $\phi = 0.4 \text{ in}$ @ $L = 10 \text{ in}$ (ensure design is safe!)

Assume: N/A

Method: 1) Sketch
 2) FBD
 3) Solve for Reactions
 4) Solve for δ_r
 5) Safe?

Solution:



FBD:

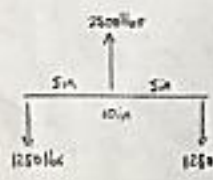

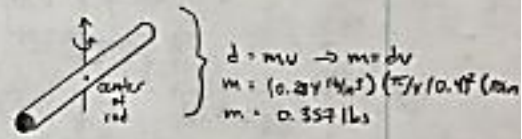

rod $\phi = 0.4 \text{ in}$

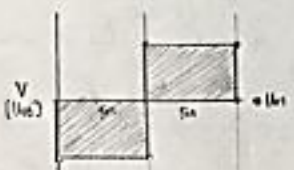

$$d = mU \rightarrow m = dV$$

$$m = (0.284 \text{ lb/in}^3) \left(\frac{\pi}{4} (0.4 \text{ in})^2 (10 \text{ in}) \right)$$

$$m = 0.357 \text{ lb}$$



$$\delta_c = \frac{FL^3}{48EI} \quad \left. \begin{array}{l} \\ \\ \end{array} \right\} I = \frac{1}{12} m d^2$$

$$\delta_c = \frac{FL^3}{(48)(\pi)(\rho)(\frac{1}{12} m d^2)}$$

$$\delta_c = \frac{(2500 \text{ lbs})(10 \text{ in})^3}{(48)(200 \text{ GPa})(\frac{1}{12}(0.357 \text{ lb})(10 \text{ in})^2)}$$

$$\delta_c = 0.087555 \text{ inches} \approx 0.1 \text{ inch}$$

Deflection of $\phi = 0.4 \text{ inch}$ pin $< 0.1 \text{ inch}$.
 Design can be considered safe.

(11) APPENDIX B – DRAWINGS

Drawing B-1: Hydraulic Cylinder – Cylinder Bore

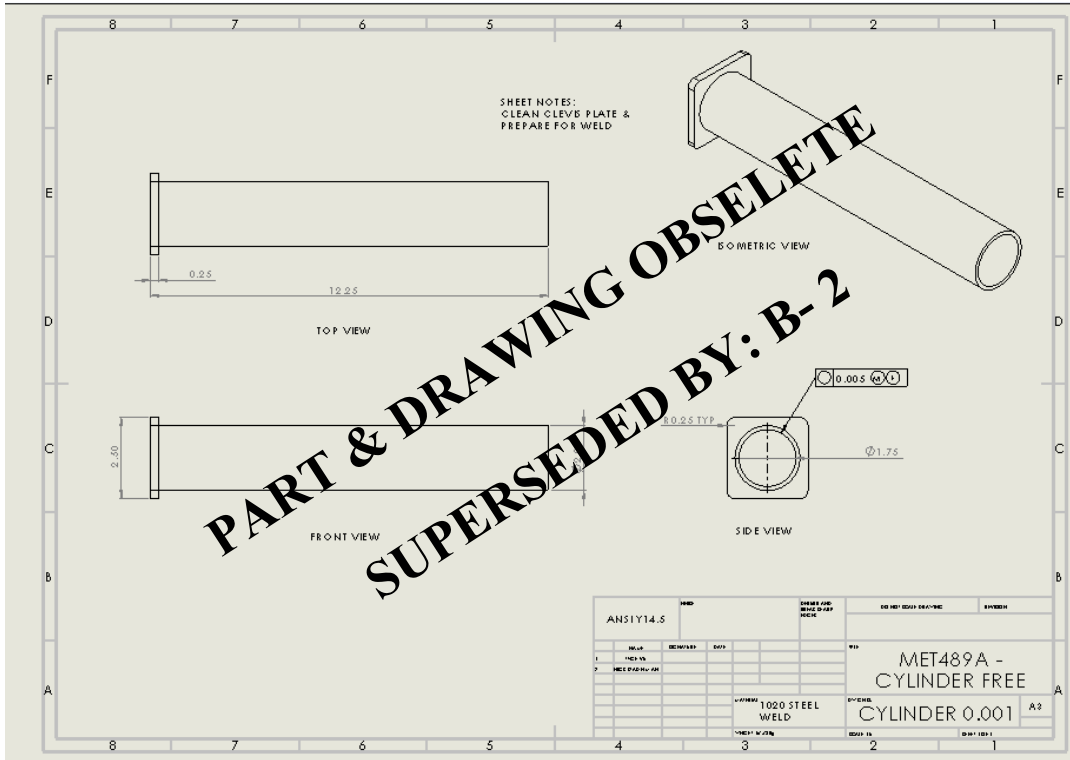

Drawing B-2: Hydraulic Cylinder – Cylinder Rod Assembly

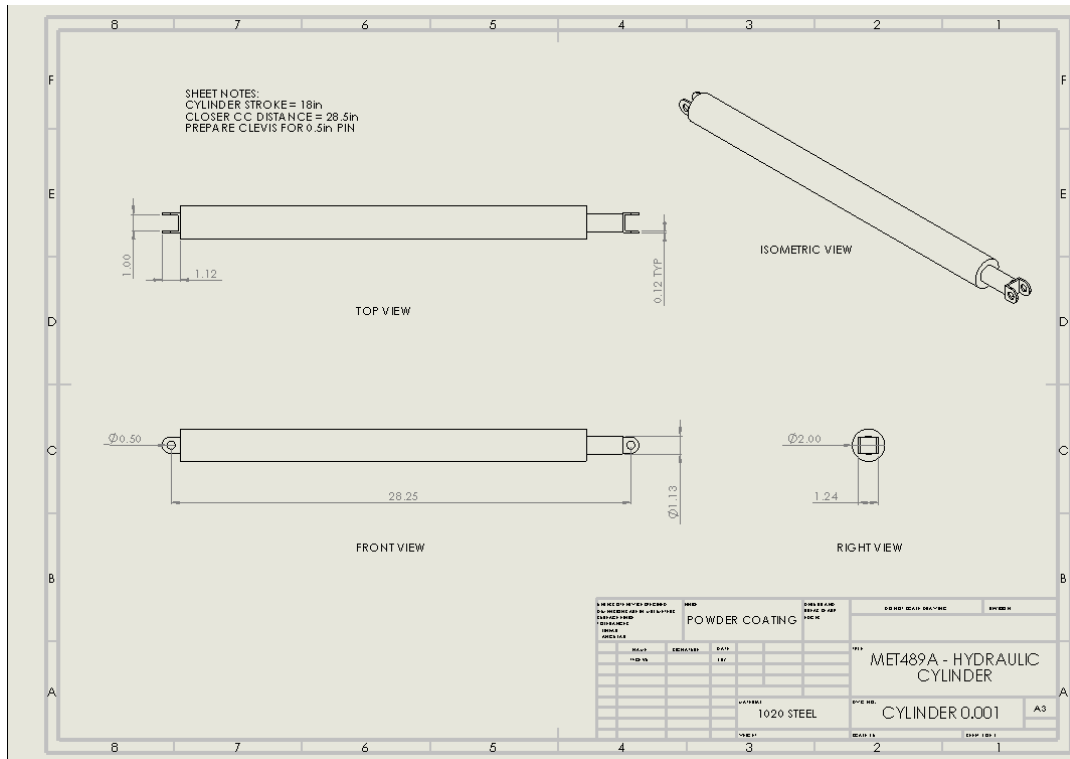

Drawing B-3: Hydraulic Cylinder Clevis Joint

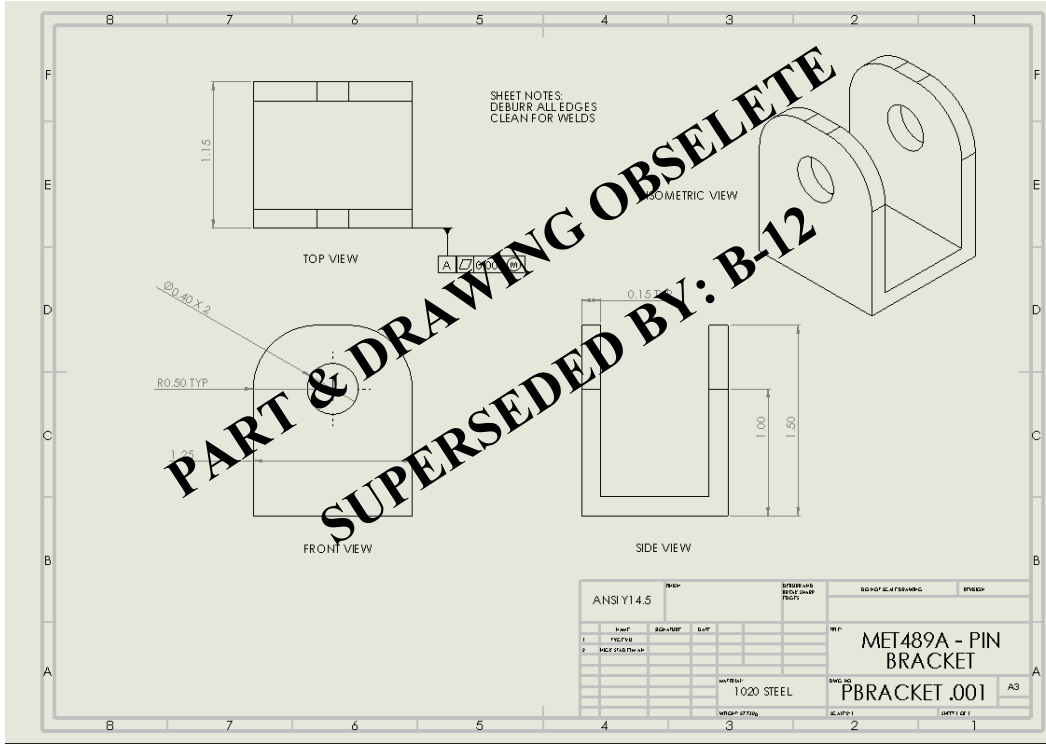

Drawing B-4: Hydraulic Cylinder – Clevis Pin

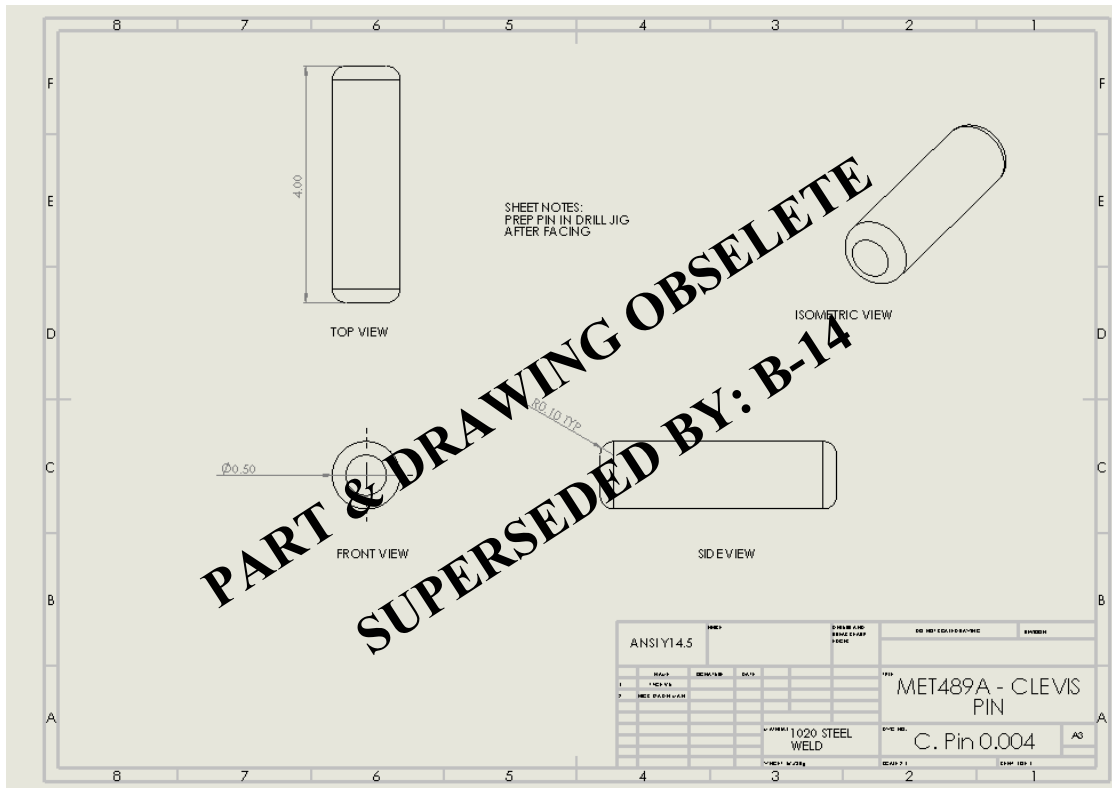

Drawing B-5: Hydraulic Cylinder – Cross Ro

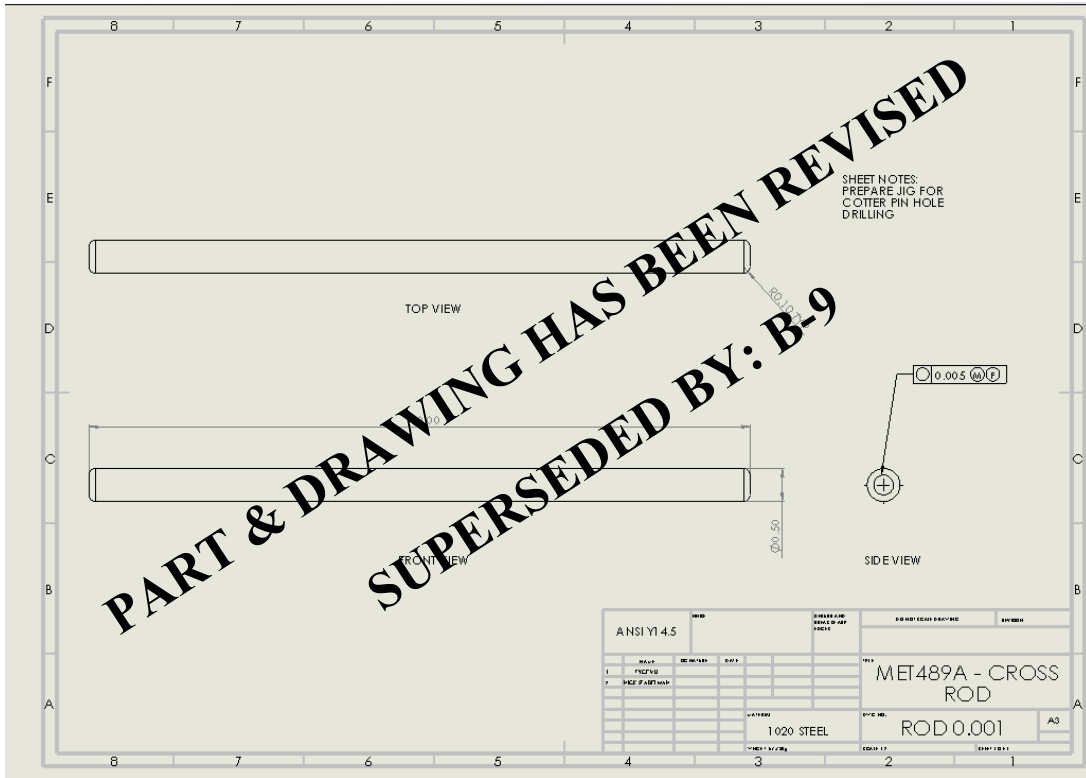

Drawing B-6: ANSI Y14.5 Assembly Drawing - Powertrain w/ Frame Fitment

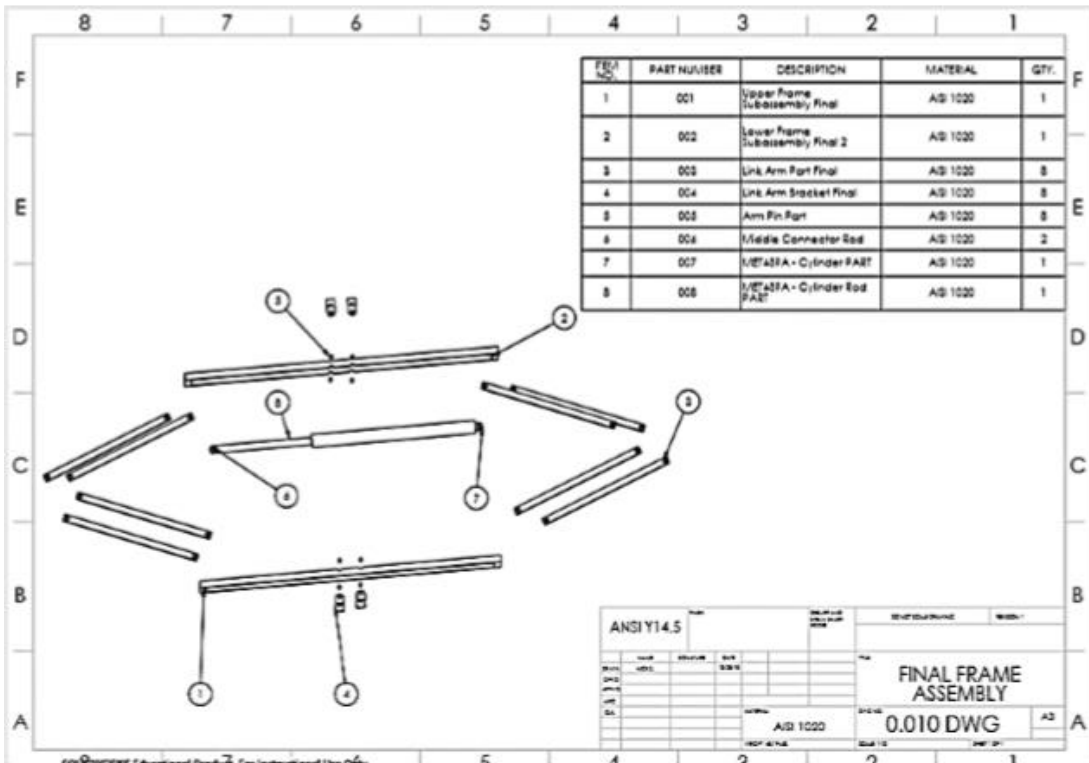

Drawing B-7: Motion Analysis Snips have been superseded by a full system assembly drawing, located below.

Drawing B-8: Shear Safety Pin

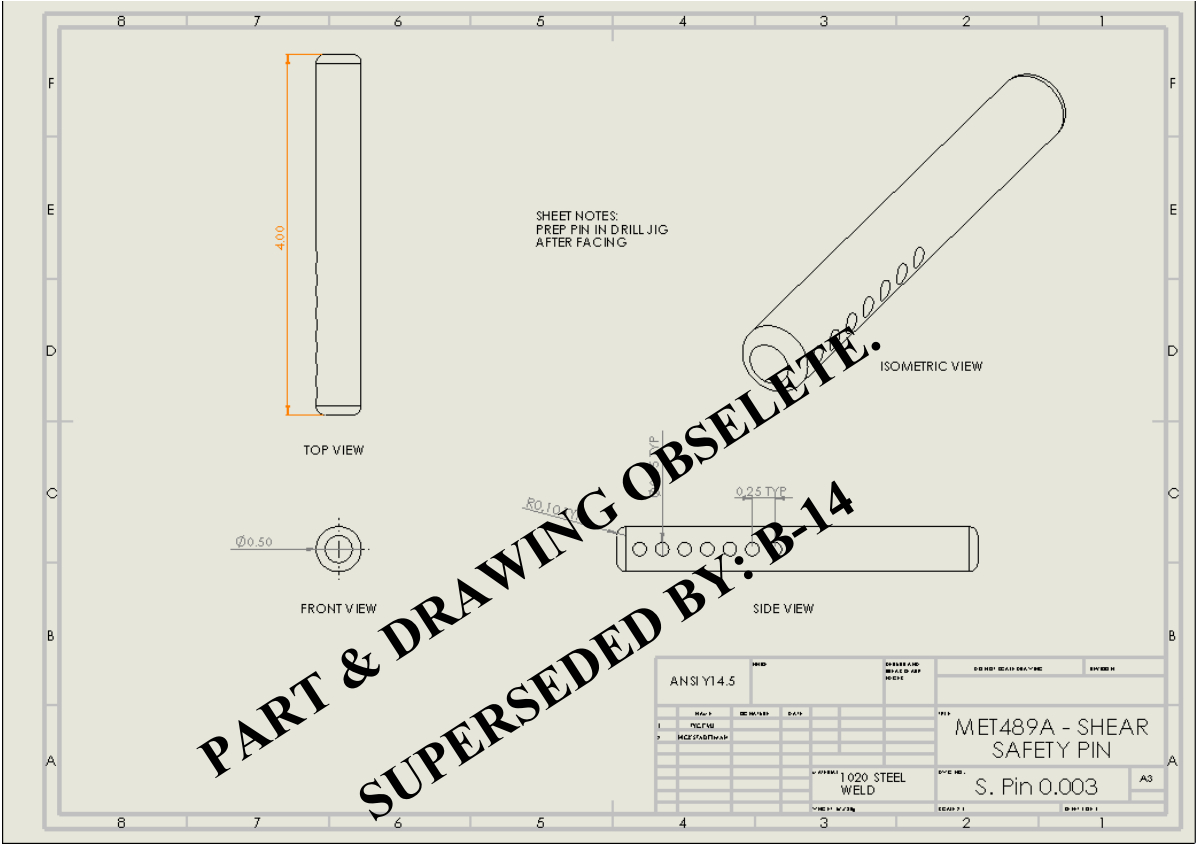

Drawing B-9: Middle Cross Rod

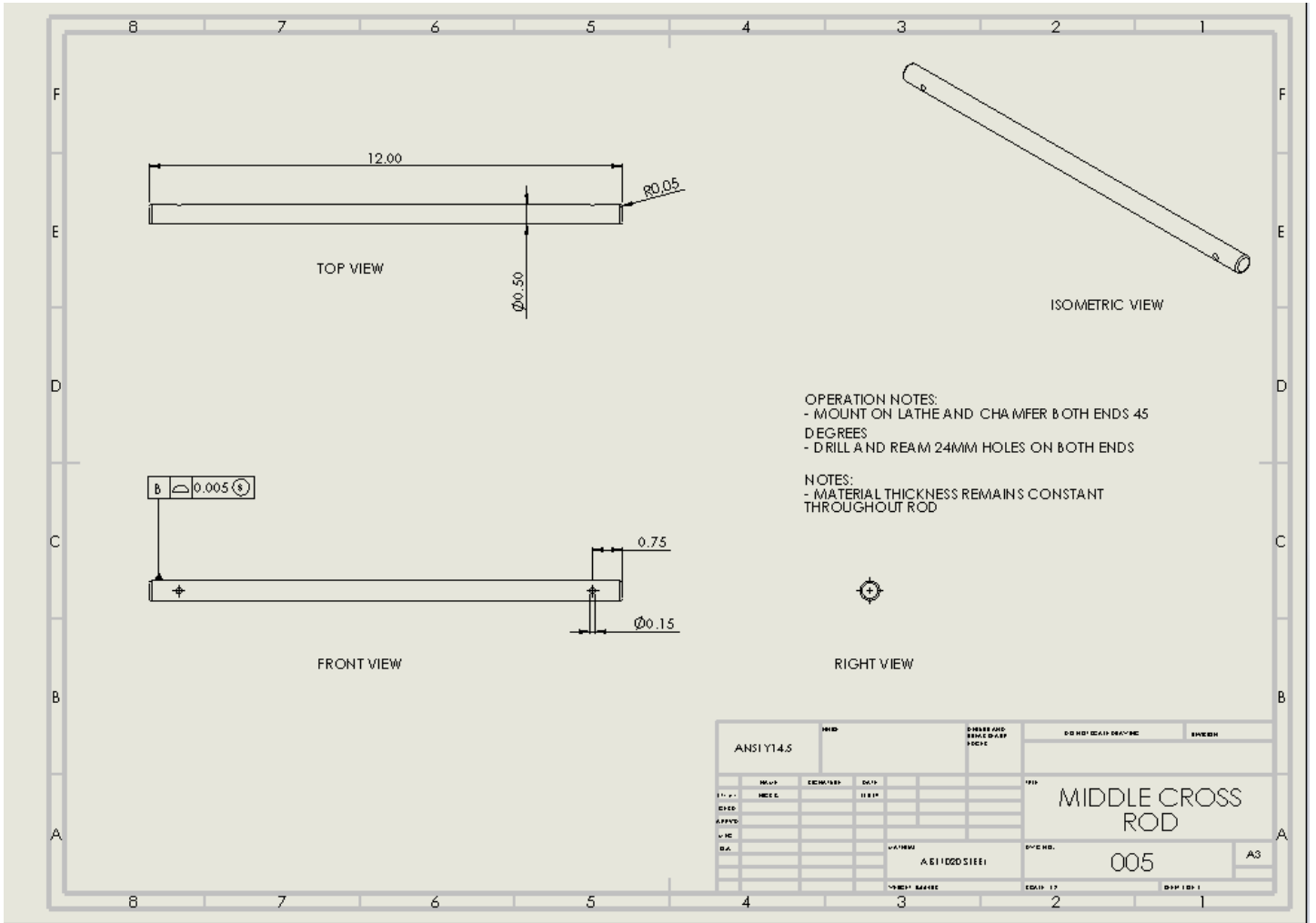

Drawing B-10: Link Arm Insert

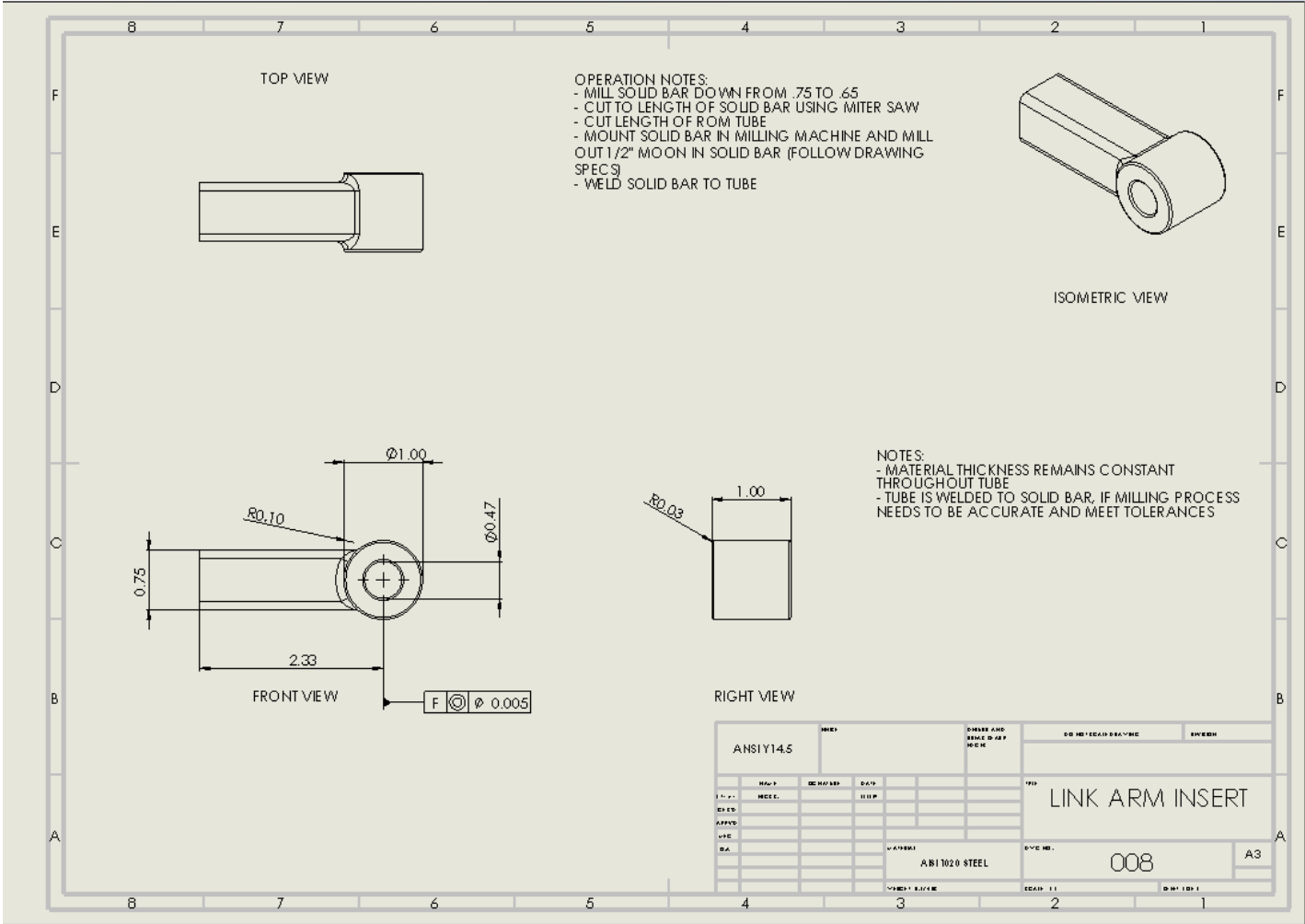

Drawing B-11: Power Unit Plate

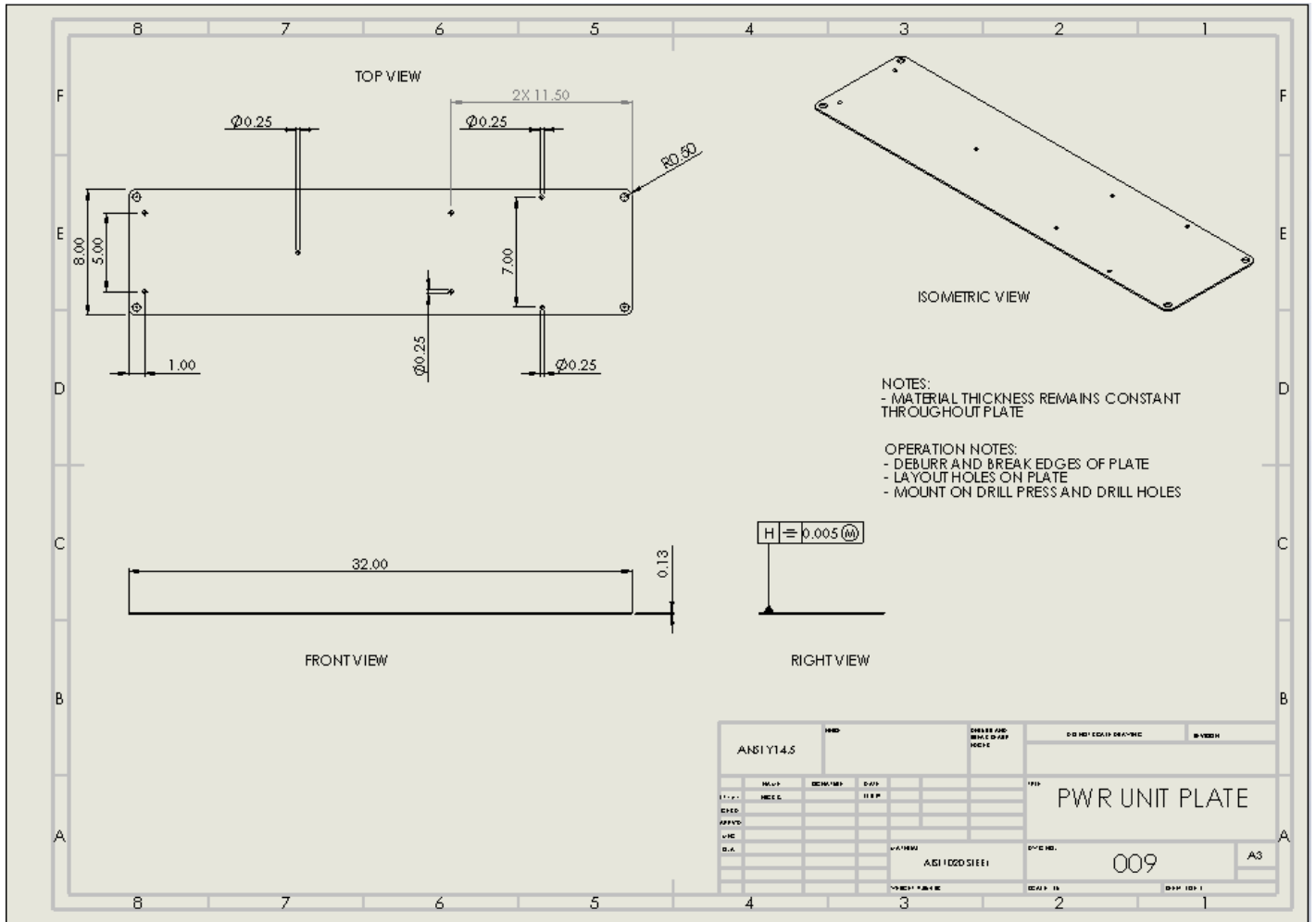

Drawing B-12: Hydraulic Clevis Sleeve

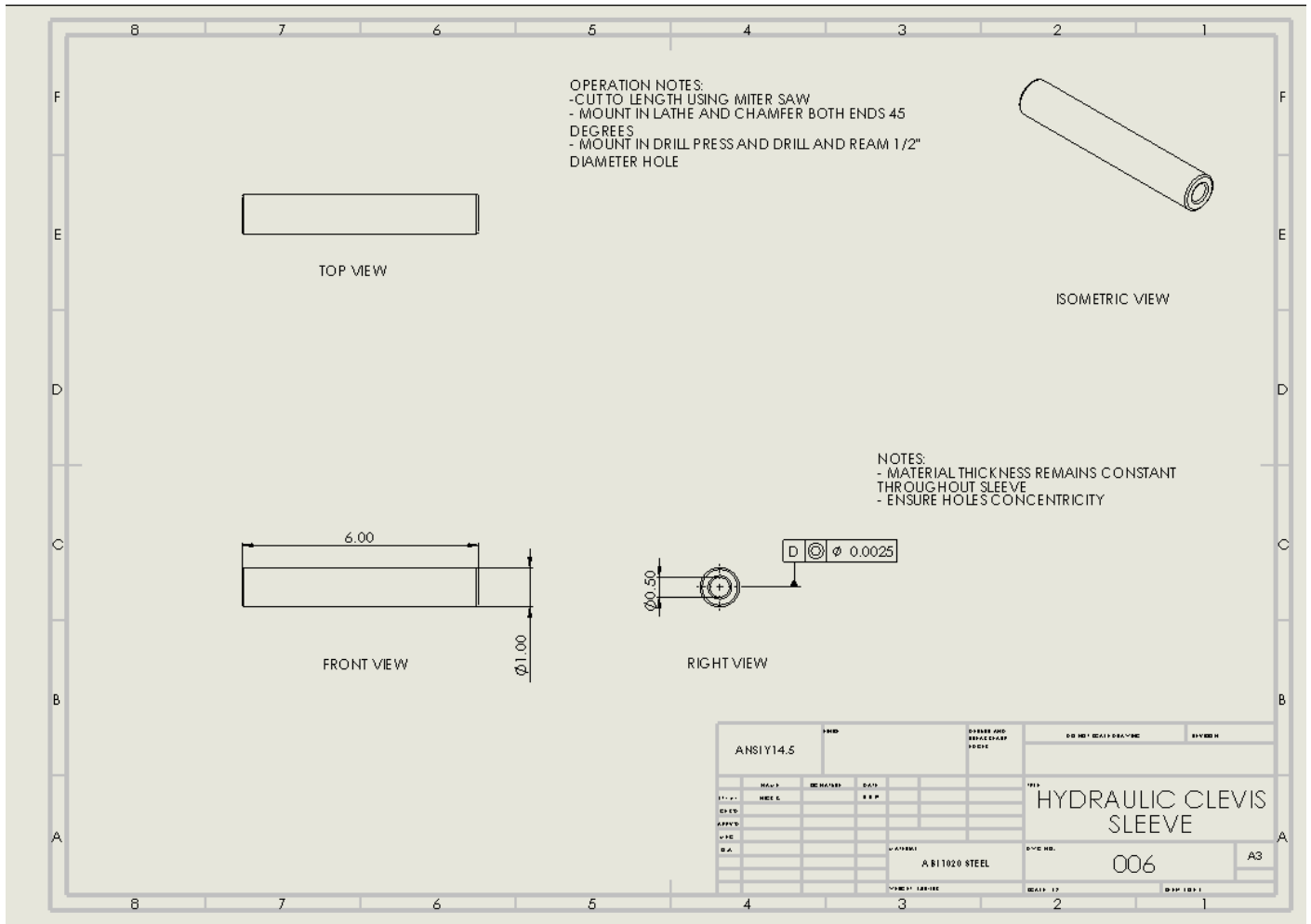

Drawing B-13: Hydraulic Line Guide

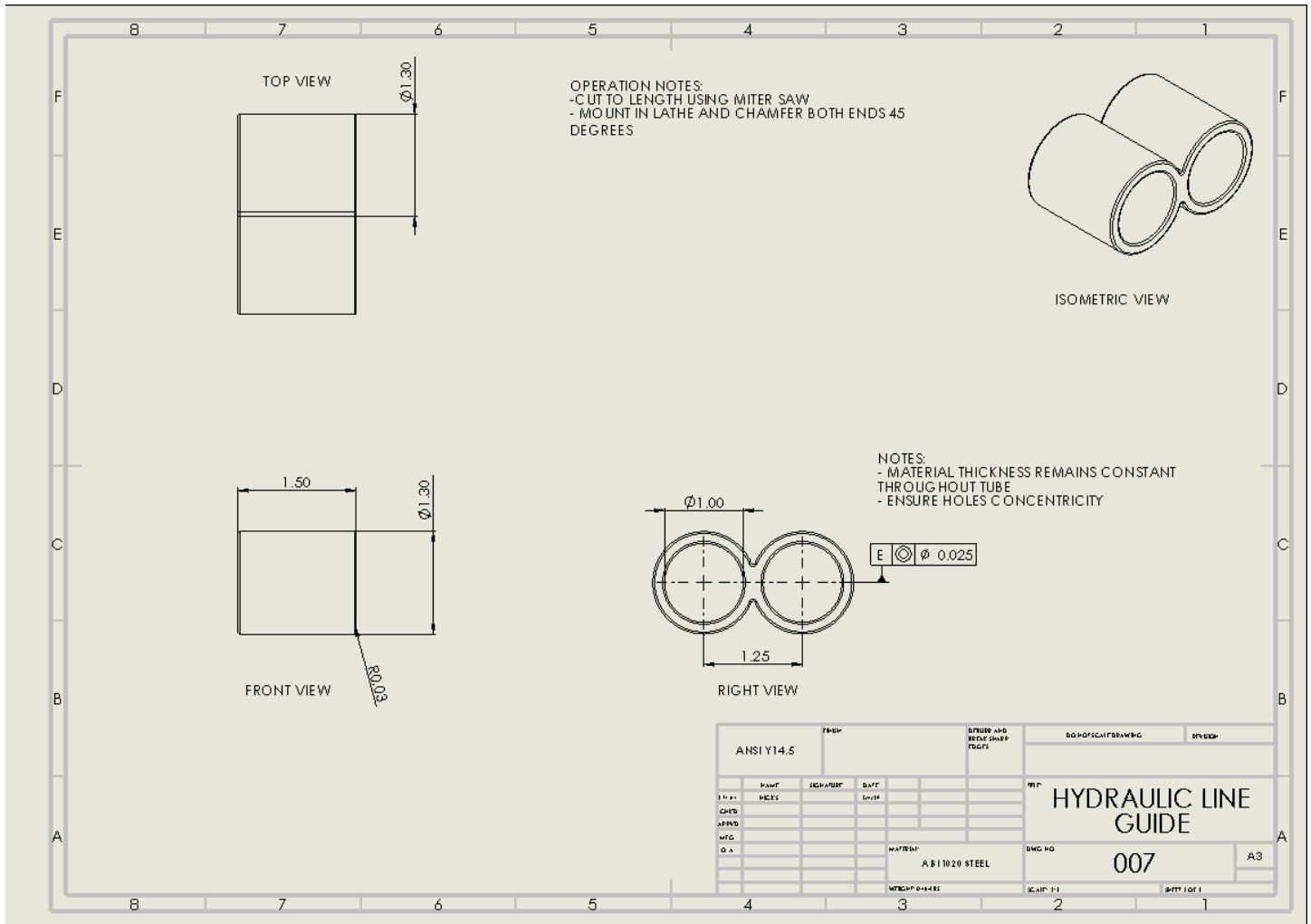

Drawing B-14: Link Arm Pin

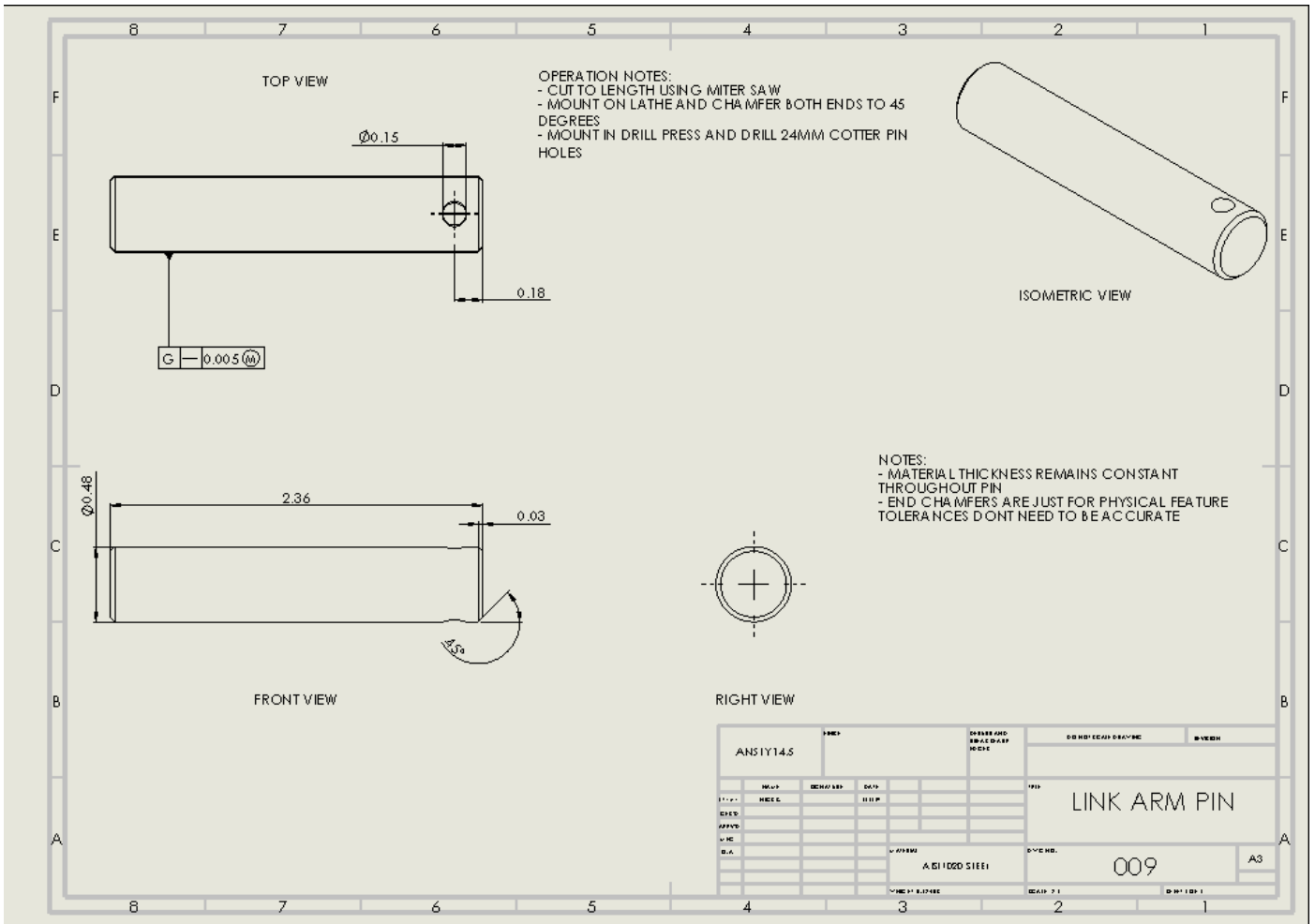

Drawing B-15: Link Arm Insert - Peg

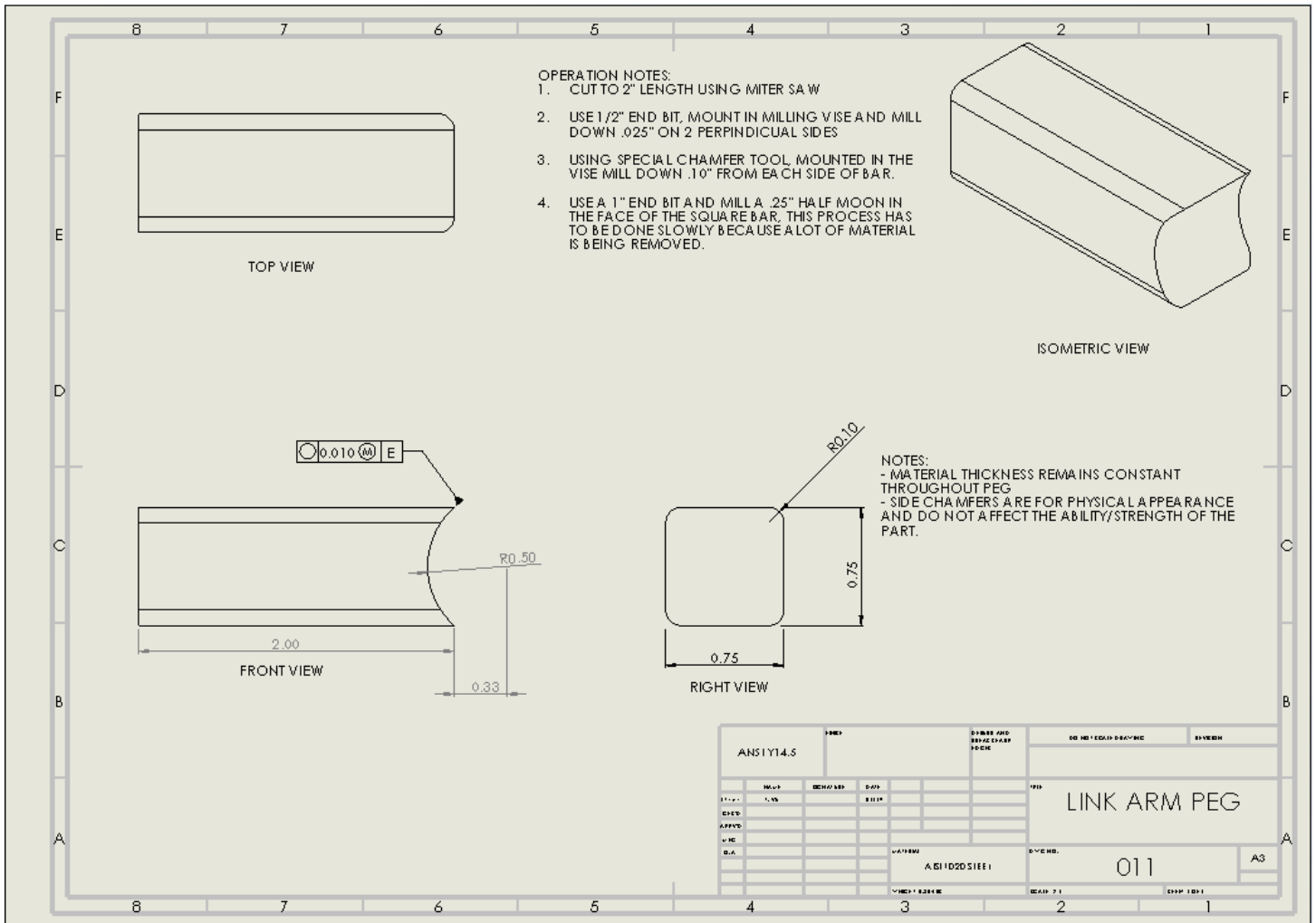

Drawing B-16: Link Arm Insert - Sleeve

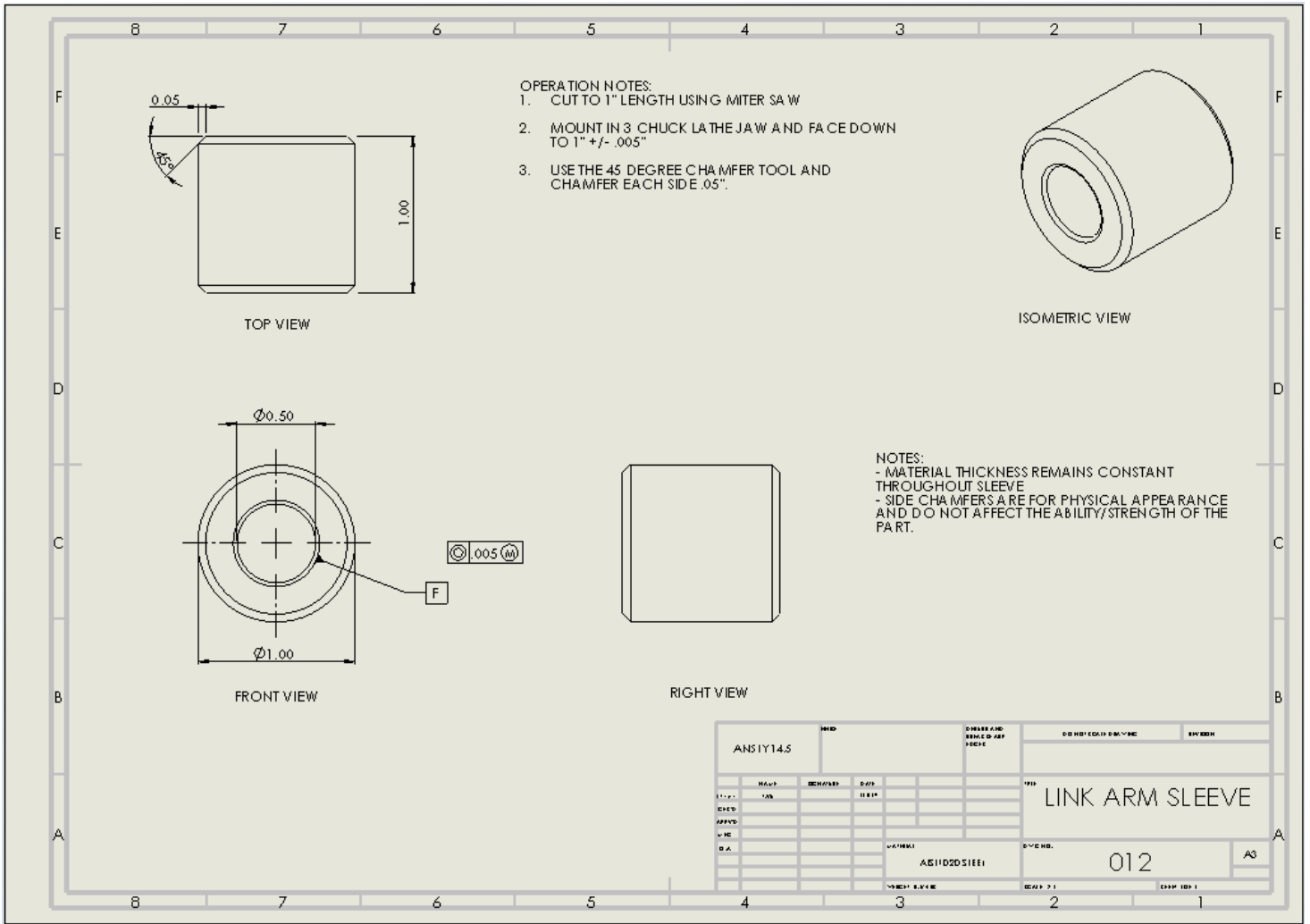

(12) APPENDIX C – PARTS LIST

Tyce Vu - MET489A - Parts & Budget Spreadsheet									
Nick Stadelman									
"AutoJack" - Powertrain System									
Item ID	Item Description	Item Source	Brand	Model/SN	Price/Cost (US Dollars - \$/hour)	Quantity (or hrs)	Cost: Subtotals	Actual \$ (Tax)	
0.01	Heavy Duty Hydraulic Cylinder - 3000 PSI, 2in. Bore, 18in Stroke.	Northern Tool	Nortrack	# 992206	\$119.99	1	\$119.99	\$119.99	\$119.99
0.02	Mophorn Hydraulic Power Unit 8 Quart Pump Double Acting 12V DC	Amazon	Mophorn	#B0GYS2TMY2	\$218.59	1	\$218.59	\$218.59	\$218.59
0.03	Steel Square Tube A500-A513 Welded - 96 inches	Metal Supermarkets	Metal Supermarkets	#HTSQ-11120	\$119.30	1	\$119.30	\$119.30	\$119.30
0.04	Hot Rolled Round 0.500 - 36 inches	Metal Supermarkets	Metal Supermarkets	#HR-500	\$5.42	1	\$5.42	\$5.42	\$5.42
0.05	Alloy Steel Dowel Pin 12mm x 60mm	McMaster-Carr	McMaster-Carr	#DING6325-M6	\$2.78	10	\$27.80	\$27.80	\$27.80
0.06	Hot Rolled Square Bar 0.750 - 48in	Metal Supermarkets	Metal Supermarkets	#HSQ/750	\$14.69	1	\$14.69	\$14.69	\$14.69
0.07	Hot Rolled Flat Bar 0.25 x 8in	Metal Supermarkets	Metal Supermarkets	#HF/2508	\$29.56	1	\$29.56	\$29.56	\$29.56
0.08	Cold Rolled Round Tube 1026 DOM - 36in	Metal Supermarkets	Metal Supermarkets	#CTR10260/1250	\$35.49	1	\$35.49	\$35.49	\$35.49
0.09	High and Low Pressure Hydraulic Lines x 10ft	John Deere	John Deere	#4549821	\$210.50	2	\$421.00	\$421.00	\$421.00
0.1	Cotter Pins 9/64in	FMW Fastners	FMW Fastners	#1802081	\$0.07	12	\$0.84	\$0.84	\$0.84
0.11	Hydraulic Fluid	Zoro	Valvoline	# G4295392	\$20.77	2	\$41.54	\$41.54	\$41.54
0.12	Swivel Stem Caster Wheels 3/8in - 16 x 1in (4 pack)	Amazon	Dicasal	#DSC-09	\$14.90	1	\$14.90	\$14.90	\$14.90
							Total Est:	Total Act:	
							\$992.68	\$992.68	

(13) APPENDIX D – BUDGET

Tyce Vu - MET489A - Parts & Budget Spreadsheet									
Nick Stadelman									
"AutoJack" - Powertrain System									
Item ID	Item Description	Item Source	Brand	Model/SN	Price/Cost (US Dollars - \$/hour)	Quantity (or hrs)	Cost: Subtotals	Actual \$ (Tax)	
0.01	Heavy Duty Hydraulic Cylinder - 3000 PSI, 2in. Bore, 18in Stroke.	Northern Tool	Nortrack	# 992206	\$119.99	1	\$119.99	\$119.99	\$119.99
0.02	Mophorn Hydraulic Power Unit 8 Quart Pump Double Acting 12V DC	Amazon	Mophorn	#B0GYS2TMY2	\$218.59	1	\$218.59	\$218.59	\$218.59
0.03	Steel Square Tube A500-A513 Welded - 96 inches	Metal Supermarkets	Metal Supermarkets	#HTSQ-11120	\$119.30	1	\$119.30	\$119.30	\$119.30
0.04	Hot Rolled Round 0.500 - 36 inches	Metal Supermarkets	Metal Supermarkets	#HR-500	\$5.42	1	\$5.42	\$5.42	\$5.42
0.05	Alloy Steel Dowel Pin 12mm x 60mm	McMaster-Carr	McMaster-Carr	#DING6325-M6	\$2.78	10	\$27.80	\$27.80	\$27.80
0.06	Hot Rolled Square Bar 0.750 - 48in	Metal Supermarkets	Metal Supermarkets	#HSQ/750	\$14.69	1	\$14.69	\$14.69	\$14.69
0.07	Hot Rolled Flat Bar 0.25 x 8in	Metal Supermarkets	Metal Supermarkets	#HF/2508	\$29.56	1	\$29.56	\$29.56	\$29.56
0.08	Cold Rolled Round Tube 1026 DOM - 36in	Metal Supermarkets	Metal Supermarkets	#CTR10260/1250	\$35.49	1	\$35.49	\$35.49	\$35.49
0.09	High and Low Pressure Hydraulic Lines x 10ft	John Deere	John Deere	#4549821	\$210.50	2	\$421.00	\$421.00	\$421.00
0.1	Cotter Pins 9/64in	FMW Fastners	FMW Fastners	#1802081	\$0.07	12	\$0.84	\$0.84	\$0.84
0.11	Hydraulic Fluid	Zoro	Valvoline	# G4295392	\$20.77	2	\$41.54	\$41.54	\$41.54
0.12	Swivel Stem Caster Wheels 3/8in - 16 x 1in (4 pack)	Amazon	Dicasal	#DSC-09	\$14.90	1	\$14.90	\$14.90	\$14.90
							Total Est:	Total Act:	
							\$992.68	\$992.68	

(14) APPENDIX E – GANTT SCHEDULE
Gantt chart continued onto next page...

MET489A-C Senior Project Gantt Schedule - Tyce Vu																	
Project Title: "Auto-Jack" - Hydraulic Powertrain System																	
Principal Investigator: Tyce Vu																	
TASK ID	Description	Duration		Comp. %	Fall Quarter - MET489A				Winter Quarter - MET489B			Spring Quarter - MET489C					
		Est. (hrs)	Actual (hrs)		Sept.	Oct.	Nov.	Dec.	Jan.	Feb.	Mar.	Apr.	May	June			
1	Proposal																
A	Table of Contents	1	2	100%	X												
B	Introduction	2	1.5	100%	X												
C	Methods and Analyses	24	12	100%	X	X	X	X	X	X	X	X	X	X	X	X	X
D	Methods and Construction	3	3	100%			X	X	X	X							
E	Testing Method	3	3	100%			X	X	X								
F	Budget/Schedule/Proj. Manage	6	6	100%		X	X	X	X	X							
G	Discussion	6	6	100%			X	X	X								
H	Conclusion	2	2	100%			X	X	X	X	X						
I	Acknowledgments	1	1	100%			X	X	X								
J	References	1	1	100%			X	X	X								
K	Appendix A	12	12	100%	X	X	X	X	X	X	X	X	X	X	X	X	X
L	Appendix B	8	8	100%	X	X	X	X	X	X	X	X	X	X	X	X	X
M	Appendix C	2	2	100%			X	X	X	X							
N	Appendix D	2	2	100%							X	X	X				
O	Appendix E	4	4	100%			X	X	X								
P	Appendix F	1	1	100%			X	X	X								
Q	Appendix G	2	2	100%			X	X	X								
R	Appendix H	2	2	100%			X	X									
S	Appendix I	2	2	100%					X	X							
T	Appendix J	1	1	100%			X	X	X								
U	Appendix K	1	1	100%													
	subtotal:	86	74.5														
2	Analyses (Green Sheets)																
A-1	Cyl. Force & Pressure Analysis	1	1	100%	X												
A-2	Cyl. Speed & Flow Rate Analysis	1	1	100%	X												
A-3	Cyl. Clevis Joint/Pin Sizing Analysis	1	1	100%		X											
A-4	Cyl. Cross Rod Deflection Analysis	1	1	100%		X											
A-5	Hydraulic Line Selection	1	1	100%			X										
A-6	Hydraulic Power Unit Analysis	1	1	100%			X										
A-7	Cyl. Motion Analysis	1	1	100%			X										
A-8	Safety Pin Shear Analysis	1	1	100%			X										
A-9	Hydraulic Fluid Volume Analysis	1	1	100%			X										
A-10	Powertrain Total Weight Analysis	1	1	100%			X										
A-11	Cyl. Clevis Pin Sizing Analysis - REDO	1	1	100%					X	X	X	X	X				
A-12	Cyl. Cross Rod Deflection Analysis - REDO	1	1	100%					X	X	X	X	X				
	subtotal:	12	12														
3	Documentation (Drawings)																
B-1	Hydraulic Cyl. - Cylinder Bore	1	1	100%	X												
B-2	Hydraulic Cyl. - Cylinder Rod Assem.	1	1	100%		X											
B-3	Hydraulic Cyl. - Clevis Joint	1	1	100%			X										
B-4	Hydraulic Cyl. - Clevis Pin	1	1	100%			X										
B-5	Hydraulic Cyl. - Cross Rod	1	1	100%			X										
B-6	Powertrain w/ Frame Fitment	2	2	100%				X									
B-7	Powertrain w/ Frame Motion	2	2	100%					X								
B-8	Shear Safety Pin	1	1	100%						X	X	X					
	subtotal:	10	10														
4	Proposal Mods																
A	Redesign Cyl. Stroke w/ Link Arms	4	3	100%					X	X	X	X	X	X			
B	Redesign Hydraulic PWR Unit	2	2	100%					X	X	X	X	X	X			
C	Critical Design Review	1	1	100%					X	X	X	X	X	X			
	subtotal:	7	6														
5	Part Construction																
A	Order Cyl. (NorTrac 992206)	0.5	0.5	100%						X	X						
B	Order PWR Unit (NorTrac 766432)	0.5	0.5	100%						X	X						
C	Order Line Kit (NorTrac 342588)	0.5	0.5	100%						X	X						
D	Order Hydraulic Fluid (Amazon)	0.5	0.5	100%						X	X						
E	Machine LA Insert Peg & Sleeve	4	13.25	100%							X	X	X	X	X	X	X
F	Machine 0.5in Cross Rod	1	1	100%							X	X	X	X	X	X	X
G	Documentation: Photograph	0.5	0.5	100%						X	X	X	X	X	X	X	X

H	Update Website	4	1	100%									X	X	X	X
I	Check Bill of Materials & Budget	1	2	100%									X	X	X	X
		subtotal:	12.5	19.75												
6	Device Construction															
A	Frame Assembly	4	3.75	100%					X	X	X	X				
B	Link Arm Assembly	4	4	100%									X	X	X	X
C	Cyl. Install/Assembly	1	1	100%												
D	Hydraulic Circuit Assembly	10	8	100%									X	X	X	X
E	Documentation: Photograph	0.5	0.5	100%									X	X	X	X
F	Update Website	1	1	100%									X	X		
		subtotal:	20.5	18.25												
7	Device Evaluation															
A	List Parameters	2	2	100%	X	X	X	X	X	X						
B	Design Test and Scope	2	2	100%	X	X	X	X	X	X						
C	Obtain Resources	6	5	100%					X	X	X	X	X	X	X	X
D	Make Test Sheets	4	3.5	100%	X	X	X	X	X	X						
E	Plan Analyses	5	5	100%	X	X	X	X	X	X						
G	Test Plan	2	2	100%	X	X	X	X	X	X						
H	Perform Device Evaluation	18	18	100%											X	X
I	Take Testing Pics	4	3	100%									X	X	X	X
J	Update Website	12.5	12.5	100%					X	X	X	X	X	X	X	X
		subtotal:	55.5	53												
8	MET489 A-C Deliverables															
A	Obtain Report Guide	6	5	100%									X	X	X	X
B	Make Report Outline	4	3.5	100%									X	X	X	X
C	Write Testing Report	4	4	100%									X	X	X	X
D	Make Slide Outline	4	4	100%									X	X	X	X
E	Create Poster Presentation - SOURCE	6	5.5	100%									X	X	X	X
F	SOURCE Presentation - May 15th 2:00pm	2.5	2.5	100%											X	
G	Write 489A parts	2	2	100%									X	X	X	X
H	Update Website	12.5	12	100%									X	X	X	X
I	Project CD	2	2	100%									X	X	X	X
		subtotal:	43	40.5												
9	Project Milestones - X															
A	Milestone 1 - Complete Proposal	100	88.5	100%	X	X	X	X	X	X	X	X	X	X	X	X
B	Milestone 2 - Complete Construction/Present	100	127.5	100%					X	X	X	X	X	X	X	X
C	Milestone 3 - Present Finished AutoJack	100	110	100%									X	X	X	X

(15) APPENDIX F - EXPERTISE AND RESOURCES

4. **Central Washington University** – Allowed MET students to access the CAD Lab, Machine Shop, Welding Shop, Hydraulics Lab and all of their resources.
5. **CWU’s Dr. Craig Johnson** – Provided guidance throughout the design phase of this project.
6. **CWU’s Charles Pringle** – Provided guidance throughout the design phase of this project.
7. **CWU’s Jeunghwan Choi** – Provided guidance throughout the design phase of this project.
8. **CWU’s Tedman Bramble** – Provided access to the Hogue Machine Shop. Supervised and provided guidance during the manufacturing phase of the project.
9. **CWU’s Mattew Burvee** - Provided access to the Hogue Machine Shop. Supervised and provided guidance during the manufacturing phase of the project.
10. **CWU’s Daryl Fuhrman** - Provided access to the Hogue Welding Shop and Hydraulics Lab. Supervised and provided guidance during the manufacturing phase of the project.
11. **Carl’s Powder Coating Service** - Provided professional powder coating service for the project during the manufacturing phase of the project.

(16) APPENDIX G –TESTING DATA

Test 1 - Data Collection Handout:

Trial #	Load (lbs)	Set Distance (in)	Time Taken (s)	Avg. Time (s)	Rate (in/s)
1	1000lbs	12in	____seconds	____seconds	____in/s
2	1000lbs	12in	____seconds		
3	1000lbs	12in	____seconds		

1	2000lbs	12in	____seconds	____seconds	____in/s
2	2000lbs	12in	____seconds		
3	2000lbs	12in	____seconds		

1	3000lbs	12in	____seconds	____seconds	____in/s
2	3000lbs	12in	____seconds		
3	3000lbs	12in	____seconds		

1	4000lbs	12in	____seconds	____seconds	____in/s
2	4000lbs	12in	____seconds		
3	4000lbs	12in	____seconds		

1	5000lbs	12in	____seconds	____seconds	____in/s
2	5000lbs	12in	____seconds		
3	5000lbs	12in	____seconds		

AutoJack System Test 4: “Lifting Applied Load”

Test 4 Given/Known Data:

Test vehicle: 2001 Ford Ranger EDGE (Super-cab, 4x4, 4.0 v6, A/T)

Test vehicle curb weight: 3599lbs (+/- 75lbs)

Test vehicle lift location: rear hitch post

Vertical travel distance: 12.5in to 36in

Vertical lift rate: 4.1in/s

Pressure Relief Valve (PRV) setting: ¾ turn from factory setting

Equations - solving for pressure in hydraulic powertrain system at stall point...

- $Force = (Mass)(Gravity\ Constant) \rightarrow F = mg$

- $Pressure = \frac{Force}{Area} \rightarrow P = \frac{F}{A}$

- $F = P_1 \left(\frac{\pi(d_2^2 - d_1^2)}{4} \right)$ where... P_1 = pressure read from gauge, $d_2 = 2in$, and $d_1 = 1in$

Test 4 - Data Collection Handout:

Trial #	Vehicle Weight (lbs)	Max System Pressure (psi)	Max AVG Pressure (psi)	Max Stall Pressure (psi)	AVG Stall Pressure (psi)	AVG Stall Weight (lbs)
1	3599lbs	1700 psi	1710 psi	N/A psi	N/A psi	N/A lbs
2	3599lbs	1200 psi		N/A psi		
3	3599lbs	2200 psi		N/A psi		
4	3599lbs	2000 psi		N/A psi		
5	3599lbs	1950 psi		N/A psi		
6	3599lbs	1800 psi		N/A psi		
7	3599lbs	1100 psi		N/A psi		

Note: In the event that the AutoJack ceases to lift the vehicle at any point during its full range of motion, use the “**stall**” columns of this table.

(17) APPENDIX H – EVALUATION SHEET

Test 1 - Data Collection Handout – Evaluation Sheet:

Trial #	Load (lbs)	Set Distance (in)	Time Taken (s)	Avg. Time (s)	Rate (in/s)
1	1000lbs	12in	____seconds	____seconds	____in/s
2	1000lbs	12in	____seconds		
3	1000lbs	12in	____seconds		

1	2000lbs	12in	____seconds	____seconds	____in/s
2	2000lbs	12in	____seconds		
3	2000lbs	12in	____seconds		

1	3000lbs	12in	____seconds	____seconds	____in/s
2	3000lbs	12in	____seconds		
3	3000lbs	12in	____seconds		

1	4000lbs	12in	____seconds	____seconds	____in/s
2	4000lbs	12in	____seconds		
3	4000lbs	12in	____seconds		

1	5000lbs	12in	____seconds	____seconds	____in/s
2	5000lbs	12in	____seconds		
3	5000lbs	12in	____seconds		

Test 4 - Data Collection Handout – Evaluation Sheet:

Trial #	Vehicle Weight (lbs)	Max System Pressure (psi)	Max AVG Pressure (psi)	Max Stall Pressure (psi)	AVG Stall Pressure (psi)	AVG Stall Weight (lbs)
1	3599lbs	1700 psi	1710 psi	N/A psi	N/A psi	N/A lbs
2	3599lbs	1200 psi		N/A psi		
3	3599lbs	2200 psi		N/A psi		
4	3599lbs	2000 psi		N/A psi		
5	3599lbs	1950 psi		N/A psi		
6	3599lbs	1800 psi		N/A psi		
7	3599lbs	1100 psi		N/A psi		

(18) APPENDIX I – TESTING REPORT

AutoJack - Hydraulic Powertrain System

Test Report Guide; a detailed account of device testing and results.

Introduction:

- **Requirements:** One of the biggest advantages that the AutoJack's design offers over other conventional jacking methods is its self-actuated hydraulic system. The hydraulic system is composed of several components, with the primary parts being the dual-acting cylinder and DC power unit. These components work together in order to transmit power through fluid and into linear motion. This system enables the AutoJack to have a consistent and steady lifting operation. Therefore, in order to maximize safety, it is absolutely critical that the hydraulic system operates as it was designed to. To ensure that the system was operating at consistent speeds and is capable of meeting Design Requirement 3; moving the maximum applied load at a minimum of 1in/s, a test was in order
- **Parameters of interest:** The test consisted of mounting the hydraulic system in a device jig and running the circuit with various applied loads. During this evaluation, the most important parameters that were monitored, measured, and recorded, were the applied loads (pounds), distance traveled (inches), and time taken (seconds). Afterwards, these values could be averaged to find the average time taken and then used to calculate linear rate (inches/second) values.
- **Predicted performance:** Before conducting the test, several hand calculations were performed on engineering green sheets. These results were used to make relevant and realistic predictions about the real-life performance of the AutoJack device. One of the benefits of using a hydraulic system is the ability to transmit massive amounts of power all while maintaining an incredibly smooth, consistent, and easy to control action. This is one of the reasons that a hydraulic powertrain was selected/designed for use in the AutoJack. Therefore, it is no surprise that the AutoJack was calculated/predicted to travel the 12in set distance in 2.55 seconds regardless of the applied load amount (for 100lbs-500lbs). According to these predictions, the hydraulic system will begin to slow at a rate of -0.085 seconds for every additional 1000lbs of applied load. This performance will continue to diminish until the AutoJack has stalled at >5,250lbs.
- **Data Acquisition:** As stated before, there were several data points acquired during testing. These included the applied load (pounds), distance traveled (inches), and time taken (seconds). Afterwards, these values could be averaged to find the average time taken and then used to calculate average linear rate (inches/second) values. It was found that on average, the AutoJack's hydraulic system was capable of traveling the 12in set distance in 2.76 seconds regardless of the applied load amount (for 100lbs-500lbs). This means that on average, the AutoJack's powertrain transmits enough power to lift the load at 4.35 in/s. Compared to the lifting design requirement of 1 in/s minimum, the powertrain system has surpassed all relevant expectations and excelled in lift speed.

- **Schedule (reference Gantt chart):** For the majority of the time, this testing phase of the AutoJack remained “on schedule”. The actual testing period only took approximately 2.5 hours. However, the test setup/re-setup took nearly 4 additional hours. This was due to the cylinder misalignment issue discovered in the first few trials runs. In order to resolve this testing issue, extra out-of-class time was allotted to the project for disassembly of the device, part/jig machining, and reassembly of the device. This extra time meant that proper care could be taken in order to correct the issue and ensure testing success (valid results). Since this was completed outside of normal class time, further testing could continue and the project Gantt chart has been successfully followed.

Method/Approach:

- **Resources (hard/soft/external, people, costs):** In order to safely conduct this test, several resources will be called upon. All necessary materials include a (1x) cylinder fixed clevis clamp jig, (1x) cylinder free plate clevis clamp jig, (1x) tape measure, (1x) medium square, (1x) roll of 3M blue masking tape, (1x) stopwatch (accurate to the nearest tenth of second), and (5x) 100lb aluminum slab(s). It was also important to have access to computer/laptop and Microsoft Excel software for data collection and analysis. Since this test will be conducted in the Hogue Power Lab with the hydraulic circuit assembled outside of the frame, a shop supervisor is also needed. Both Mr. Burvee and Mr. Bramble have volunteered their time to help conduct this test. The cost of this test is \$0.00, since all required materials are available to MET students at no cost.
- **Data capture/doc/processing:** To collect data in the most efficient manner possible, a student laptop with Microsoft Excel software was utilized. While testing, data points were quickly written on green sheet scratch paper and then input into a pre-made data collection table handout.
- **Test procedure overview:** The test consisted of mounting the hydraulic system in a device jig and running the circuit with various applied loads. During evaluation, several measurements such as load/distance/time were taken and recorded. Afterwards, these values could be used to calculate averages and rate. Obtaining these final values would confirm whether or not the AutoJack had successfully met Design Requirement 3; moving the maximum applied load at a minimum of 1in/s.
- **Operational limitations:** In order to more thoroughly conduct this test, testing objects that are safe to lift and are also of great weight (>1000lbs) are required. Since it has proven difficult to obtain such objects, this test has an operational limitation. During this test, it was only possible to run trials with loads ranging from 100lbs-500lbs +/-25lbs because of the available materials. If heavier and stable lifting objects can be acquired, the test can be conducted more thoroughly.
- **Precision and accuracy discussion:** While testing, there was an issue with the cylinder-clamp jig(s) alignment, which rendered the results from each trial inaccurate and invalid. To better explain, when providing power to the circuit, the cylinder-clamp jigs would

come out of perpendicular alignment. This would cause the cylinder to extend out at an angle and travel farther than the desired distance. Due to additional traveling distance, each test trial required a greater time window. It is also important to note that the degree at which the jig setup would misalign itself was completely random. Therefore, each traveled distance was completely random and likewise, so was the measured elapsed times. Due to these reasons, further testing was paused until a solution has been implemented. In order to resolve these testing issues, extra out-of-class time was allotted to the project and additional care was taken to correct and ensure testing success. For the cylinder misalignment issue, the clamp jigs and connecting clevis pins were disassembled and taken back to the machine shop for a boring/turning operation. Using the lathe, the jig holes were re-bored to accept a larger 1.0in diameter pin. Afterwards, the clevis pins were turned down to 0.975in diameter(s). The powertrain system was then reassembled with the fresh parts. These precisely machined parts allowed the jigs, pins, and cylinder to fit together much tighter. This eliminated all system wobble, and thereby eliminated the room for misalignment. Therefore, the results from Test 1 were both as precise and accurate as possible.

- **Data storage/manipulation/analysis:** Once the data collection table handout had been completed, the applied load, distance traveled, and time taken columns were ready for further calculation. Excel was configured to automatically average the time values and then work backwards to calculate linear rate (in/s) values using $rate = distance/time$. These results were verified by hand and checked against predicted values to ensure validity. This yielded the most reliable and realistic results possible.
- **Data presentation:** Before testing, Microsoft Excel software was used to create a data collection table sheet. Then, during testing, data points were quickly written on green sheets (scratch paper) and then input into the pre-made data collection table directly through Excel. This has been presented in table format, DR list format, and paragraph format.

Test Procedure:

- **Summary/overview:** The AutoJack is a device designed to rapidly lift and secure the rear/front end(s) of a vehicle without requiring the user to get underneath the chassis of the vehicle, thereby, improving safety. The powertrain system of the AutoJack consists of several electric and hydraulic components that are responsible for providing the necessary power to lift the 5000lb vehicle in a desired amount of time. The AutoJack has been pictured to the right for reference. During its testing phase, the AutoJack will undergo several mechanical powertrain tests. These tests will determine whether or not the powertrain system of the AutoJack has successfully met the set design requirements. In order to evaluate the overall functionality and performance of the AutoJack, all of these mechanical (powertrain + frame) must be considered, therefore, some of powertrain tests will be conducted simultaneously with other frame tests. In order to test that the AutoJack's hydraulic system is operating smoothly and at the correct speed, a "Hydraulic Speed Test - Loaded" will be conducted. This test will ensure that the hydraulic cylinder and power unit are functioning properly and are capable of moving the maximum applied

load at a rate of 1in/s.

- **Specify time, duration:** Since this test deals with hydraulic fluid and moving actuators, there are inherent safety risks. Extra caution must be taken. Therefore, there will be approximately 2 hours required for test setup. The testing portion of this evaluation will last approximately 2 hours. The test teardown has been allotted 1.5 hours.
- **Place:** This test will be conducted within the CWU Hogue Hall, Power Lab, Room 127.
- **Resources needed:** This test will be conducted in the Power Lab with the hydraulic circuit assembled outside of the frame. The other necessary materials have been listed: (1x) cylinder fixed clevis clamp jig, (1x) cylinder free plate clevis clamp jig, (1x) tape measure, (1x) roll of 3M blue masking tape, (1x) stopwatch (accurate to the nearest tenth of second), (5x) 1000lb slab, (1x) data collection sheet (see below for pre-made handout), Equation: $distance = (rate)(time) \rightarrow r = \frac{d}{t}$.
- **Specific actions to complete the test (Procedure):**
 1. Gather all necessary resources listed in the “Resources required” section of this Test Plan.
 2. Locate resources into the Hogue Hall Power Lab, Room 127.
 3. Locate a clean testing area with ample space, and a nearby spill kit.
 4. Ensure that the hydraulic circuit is disconnected from any power source (battery/wall socket).
 5. Lift the rear end of the hydraulic cylinder into the fixed clevis clamp jig and secure using a 1in diameter -1020 steel dowel pin. Use the provided cotter pin to lock in the 1in clevis pin.
 6. Lift the front end of the hydraulic cylinder into the free plated clevis clamp jig and secure using a 1in diameter -1020 steel dowel pin. Use the provided cotter pin to lock in the 1in clevis pin.
 7. Using the tape measure, measure out distance to be traveled (12in) on the ground. This distance should be co-linear with the stroke of the cylinder. Mark the start, travel path, and end using 3M blue masking tape.
 8. Connect the hydraulic power unit to its 12v battery source.
 9. Place a 1000lb slab in front and against the free plated clevis clamp jig. Use the available foundry crane for positioning.

10. Using the power unit directional control unit, begin extending the hydraulic cylinder. At the moment that the cylinder is actuated, begin the stopwatch. As soon as the clevis of the cylinder has passed the finish mark, stop the timer.
 11. Record data in data collection handout. ‘
 12. Repeat steps 9-11 two more times for a total of 3, 1000lb trials.
 13. Compute Averages and Rate results using $r = \frac{d}{t}$.
 13. Repeat steps 9-13 with 2000lb, 3000lb, 4000lb, and 5000lb loads. ‘
 14. Clean up testing area.
- **Risk/safety/evaluation readiness/other:** Since this test deals with hydraulic fluid, moving actuators, and heavy loads, there are inherent safety risks. Extra caution must be taken. All personal participating in this test are required to wear ANSI Z87 approved safety glasses and Nitrile gloves. A spill kit should be prepared and placed nearby the testing area in case of an emergency.
 - **Discussion:** This test will ensure that the hydraulic cylinder and power unit are functioning properly and are capable of moving the applied load(s) at a constant rate of 1in/s. The overall success of the AutoJack design can be measured by utilizing a success criterion rubric during the testing phase. By doing so, the performance of the AutoJack can be quantified as it will either meet or fall short of each design requirement.

Deliverables:

- **Parameter values:** Parameter values to be monitored, measured, and recorded include the “applied load(s)” in pounds, the “distance traveled” in inches, and “time taken” in seconds. Other parameter values also relative to the AutoJack powertrain system include “test vehicle curb weight” in pounds, “vertical travel distance” in inches, “vertical lift rate” in inches/second, “PRV setting” in ¼ turns, “maximum system pressure” in psi, and “maximum stall pressure” in psi.
- **Calculated values** Calculated values to be obtained from the parameter values include the “average time taken” in seconds and the “average linear rate” in inches/second. Other calculated values relative to the AutoJack powertrain system include “maximum average pressure” in psi, “average stall pressure” in psi, and “average stall weight” in pounds.
- **Success criteria values:** Using a testing decision matrix, it has been ruled that DR #3 has a success criteria value of 3.8/5. Therefore, the speed and consistency of the AutoJack’s lifting operation has a significant impact to the success rating of the device.
- **Conclusion:** Overall, the AutoJack’s hydraulic system was capable of traveling the 12in set distance in 2.76 seconds. This value remained steady regardless of the applied load amount (tested 100lbs-500lbs). This means that even with a wide range of loads, the

AutoJack’s powertain can operate consistently and move at 4.35 in/s on average. When compared to the lifting design requirement of 1 in/s minimum, the powertrain system has surpassed all relevant expectations and excelled in lift speed. Therefore, the AutoJack can be considered successful in Test 1.

Report Appendix

• **Data forms:**

Test 1 - Data Collection Handout:

Trial #	Load (lbs)	Set Distance (in)	Time Taken (s)	Avg. Time (s)	Rate (in/s)
1	100lbs	12in	____seconds	____seconds	____in/s
2	100lbs	12in	____seconds		
3	100lbs	12in	____seconds		

1	200lbs	12in	____seconds	____seconds	____in/s
2	200lbs	12in	____seconds		
3	200lbs	12in	____seconds		

1	300lbs	12in	____seconds	____seconds	____in/s
2	300lbs	12in	____seconds		
3	300lbs	12in	____seconds		

1	400lbs	12in	____seconds	____seconds	____in/s
2	400lbs	12in	____seconds		
3	400lbs	12in	____seconds		

1	500lbs	12in	____seconds	____seconds	____in/s
2	500lbs	12in	____seconds		
3	500lbs	12in	____seconds		

Test 4 - Data Collection Handout:

Trial #	Vehicle Weight (lbs)	Max System Pressure (psi)	Max AVG Pressure (psi)	Max Stall Pressure (psi)	AVG Stall Pressure (psi)	AVG Stall Weight (lbs)
1	3599lbs	1700 psi		N/A psi		

2	3599lbs	1200 psi	1710 psi	N/A psi	N/A psi	N/A lbs
3	3599lbs	2200 psi		N/A psi		
4	3599lbs	2000 psi		N/A psi		
5	3599lbs	1950 psi		N/A psi		
6	3599lbs	1800 psi		N/A psi		
7	3599lbs	1100 psi		N/A psi		

Note: In the event that the AutoJack ceases to lift the vehicle at any point during its full range of motion, use the “**stall**” columns of this table.

- Gantt chart with test day details:**

Note: Test 1 was conducted on March 27th and 28th in the Hogue Hall Power Lab, Room 126. Please see the attached report for a complete list of AutoJack tests and their corresponding Gantt schedules.

- Procedure checklist:** Procedure, Steps 1-14 have been checked and verified to be complete and valid. Mr. Burvee has supervised and aided in the completion of the testing of the AutoJack device. Please see the attached “Test 1 – “Hydraulic Speed Test Loaded” – Test Procedure Setup Figure” below for procedure check, setup confirmation, and to use as a secondary checklist.

7	Device Evaluation																										
A	List Parameters	2	2	100%	X	X	X	X	X	X																	
B	Design Test and Scope	2	2	100%	X	X	X	X	X	X																	
C	Obtain Resources	6	5	100%							X	X	X	X	X	X	X	X	X								
D	Make Test Sheets	4	3.5	100%	X	X	X	X	X	X																	
E	Plan Analyses	5	5	100%	X	X	X	X	X	X																	
G	Test Plan	2	2	100%	X	X	X	X	X	X																	
H	Perform Device Evaluation	15	6	40%																		X	X	X			
I	Take Testing Pics	4	1	25%																		X	X	X			
J	Update Website	15	8	50%							X	X	X	X	X	X	X	X	X	X	X	X	X	X			
		subtotal:	55	34.5																							
8	MET489A Deliverables																										
A	Get Report Guide	5	2	40%																		X	X	X			
B	Make Rep Outline	1	0	0%																		X					
C	Write Report	1	0	0%																		X					
D	Make Slide Outline	1	0	0%																							
E	Create Presentation	1	0	0%																							
F	Make CD Deliv. List	1	0	0%																							
G	Write 489A parts	1	0	0%																							
H	Update Website	1	0	0%																							
I	Project CD	1	0	0%																							
		subtotal:	13	2																							
9	Project Milestones - X																										
A	Milestone 1 - Complete Proposal	100	88.5	100%	X	X	X	X	X	X	X	X	X	X	X	X	X										
B	Milestone 2 - Complete Construction/Present	100	127.5	100%								X	X	X	X	X	X	X	X	X	X	X	X	X			
C	Milestone 3 - Present Finished AutoJack	100	0	0%																		X	X	X			

Hydraulic Speed Test Loaded" - - Test Procedure Setup figure

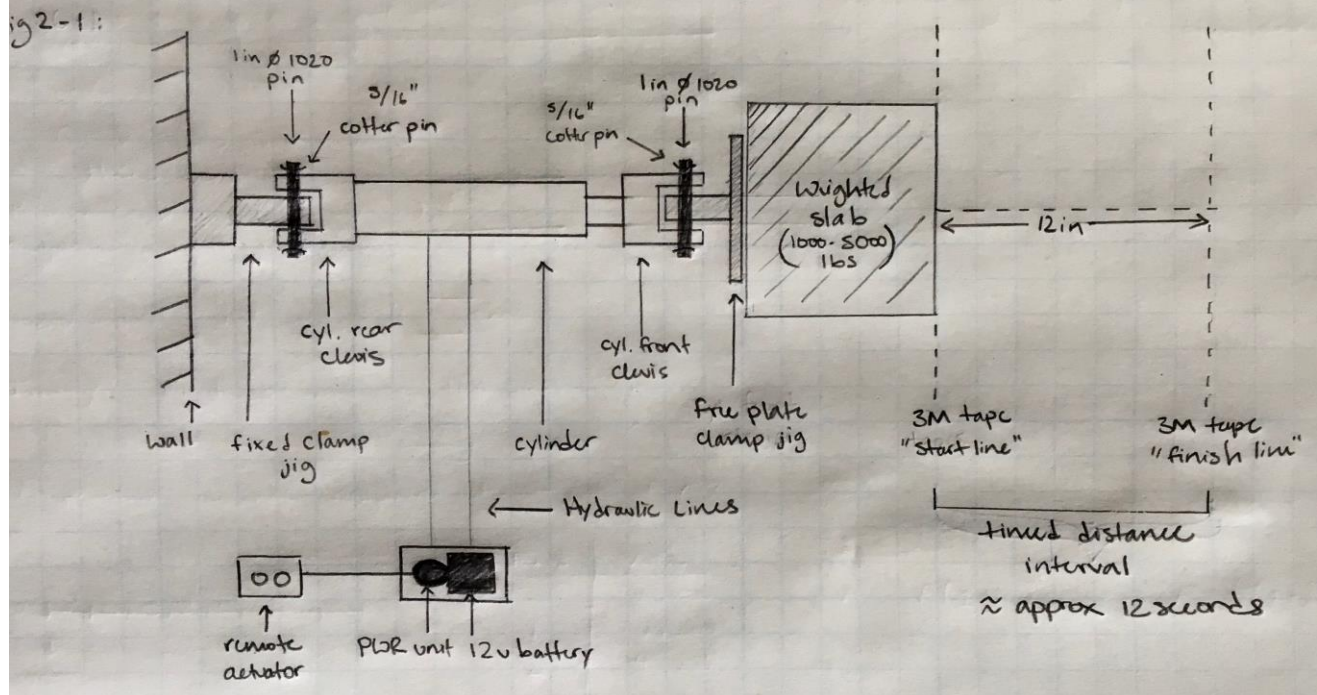
**Risk/Safety/Readiness:**

Since this test deals with hydraulic fluid, moving actuators, and heavy loads, there are inherent safety risks. Extra caution must be taken. All personal participating in this test are required to wear ANSI Z87 approved safety glasses and Nitrile gloves. A spill kit should be prepared and placed nearby the testing area in case of an emergency.

Discussion:

This test will ensure that the hydraulic cylinder and power unit are functioning properly and are capable of moving the applied load(s) at a constant rate of 1in/s. The overall success of the AutoJack design can be measured by utilizing a success criterion rubric during the testing phase. By doing so, the performance of the AutoJack can be quantified as it will either meet or fall short of each design requirement.



(19) APPENDIX J – JOB HAZARD ANALYSIS FORMS

Engineering Technologies, Safety, and Construction Department

**JOB HAZARD ANALYSIS
Complete Hydraulic Cylinder Assembly/Installation**

Prepared by: Tyce Vu	Reviewed by:
	Approved by:

Location of Task:	CWU Power (Hydraulic) Lab – Hogue 131
Required Equipment / Training for Task:	ETSC Safety Policy and Agreement - Power Lab Hydraulic Circuit Construction Training – MET310
Reference Materials as appropriate:	Link: https://www.atsdr.cdc.gov/phs/phs.asp?id=755&tid=141

Personal Protective Equipment (PPE) Required						
(Check the box for required PPE and list any additional/specific PPE to be used in "Controls" section)						
						
Gloves	Dust Mask	Eye Protection	Welding Mask	Appropriate Footwear	Hearing Protection	Protective Clothing
<input checked="" type="checkbox"/>	<input type="checkbox"/>	<input checked="" type="checkbox"/>	<input type="checkbox"/>	<input checked="" type="checkbox"/>	<input type="checkbox"/>	<input checked="" type="checkbox"/>
Use of any respiratory protective device beyond a filtering facepiece respirator (dust mask) is voluntary by the user.						

PICTURES (if applicable)	TASK DESCRIPTION	HAZARDS	CONTROLS
Coming Soon	Cylinder Circuit Construction (testing for proper stroke)	Hazardous Fluid Injection (into skin)	Use proper practice when assembling circuit and testing cylinder for proper stroke. Have supervisor check over work for proper connections.
Coming Soon	Hydraulic Reservoir Setup	Hydraulic Fluid Spills	Use proper practice when handling hydraulic fluids. Have spill kit nearby and ready for emergency.
Coming Soon	Cylinder Clevis (testing)	Hazardous Motion (pinching or crushing)	Use proper practice and actuate hydraulic circuit from a safe distance. Utilize all PPE's.

(20) APPENDIX K – RESUME

Tyce Vu, EIT

Email: VuTy@cwu.edu

Mechanical Engineering Technology:

Central Washington University Senior MET major, anticipating graduation in the Spring of 2019. ABET accredited. Scheduled to take FE exam and obtain EIT status upon completion of coursework at CWU. Seeking employment from a company that offers a challenging and rewarding work experience where I can operate at my full potential. Heavily interested in product design, product prototyping and testing, and project management.

Education:

B.S Degree, Mechanical Engineering Technology *Fall 2016 – Spring 2019*
GPA: 3.9 Cum Laude
Central Washington University, Ellensburg, WA

Running Start AA Degree, Associate of Arts *Fall 2014 – Spring 2016*
GPA: 3.6 Cum Laude
Green River College, Auburn, WA

Coursework:

Thermodynamics – Fluid Dynamics – Technical Dynamics – Heat Transfer
Statics – Strength of Materials – Applications of Strength of Materials
Mechanical Design I – Mechanical Design II – Finite Element Analysis
Machining – Hydraulics & Pneumatics – Welding – Casting Processes – Technical Writing

Proficiencies:

- Dassault Systemes Solidworks (Certified Solidworks Associate – CSWA)
- Autodesk AutoCAD, Inventor, and Nastran in-CAD (Finite Element Analysis Method)
- Microsoft Office Programs (Word & Excel)
- PlasmaCAM DesignEdge
- Experienced with casting processes, machining, welding, and hydraulic/pneumatic circuits
- Experienced with 3D printing and additive manufacturing methods
- Drafting: creating and reading engineering drawings (ANSI Y14.5 GD&T familiar)
- Teamwork: works effectively as a team member to achieve the greater goal
- Problem solving: constantly looking for new and innovative approaches to solving tasks
- Technical communication: skilled in written, electronic, and oral
- Interpersonal communication: skilled in developing lasting relationships with clients

Prior Work Experience:

Engine Machinist *Summer 2014 – Summer 2018*
Machined, repaired and assembled high output powertrains found in high performance vehicles, both domestic and international. Experienced with engine cylinder head assembly, lower crank rotational assembly, forced induction systems, ignition/fuel mapping, and transmission gearbox repair.
Vu's Auto, Auburn, WA