

2010

A CAD/CAM/CNC Curriculum for High School Students

Cory Patrick Torppa
Central Washington University

Follow this and additional works at: https://digitalcommons.cwu.edu/graduate_projects



Part of the [Secondary Education and Teaching Commons](#), and the [Vocational Education Commons](#)

Recommended Citation

Torppa, Cory Patrick, "A CAD/CAM/CNC Curriculum for High School Students" (2010). *All Graduate Projects*. 121.
https://digitalcommons.cwu.edu/graduate_projects/121

This Graduate Project is brought to you for free and open access by the Graduate Student Projects at ScholarWorks@CWU. It has been accepted for inclusion in All Graduate Projects by an authorized administrator of ScholarWorks@CWU. For more information, please contact pingfu@cwu.edu.

NOTE:

SIGNATURE PAGE OMITTED FOR SECURITY REASONS

THE REGULATIONS FOR SIGNATURE PAGES CAN BE

FOUND ON CWU'S GRADUATE STUDIES WEBPAGE:

CWU.EDU/MASTERS/

A CAD/CAM/CNC CURRICULUM FOR
HIGH SCHOOL STUDENTS

A Project Report

Presented to

The Graduate Faculty

Central Washington University

In Partial Fulfillment
of the Requirements for the Degree
Master of Education
Master Teacher

by

Cory Patrick Torppa

June 2010

ABSTRACT

A CAD/CAM/CNC CURRICULUM FOR HIGH SCHOOL STUDENTS

by

Cory Patrick Torppa

June 2010

The need for CAD/CAM/CNC curriculum for Washington State was researched. Based on research a resource workbook for CAD/CAM/CNC was in demand. In order to meet the demand for CAD/CAM/CNC curriculum and bridge the gap between the state standards, drafting frameworks, STEM curriculum, increased focus on implementation within multiple disciplines, providing a starting point for teachers who want to use CNC machinery in their program, and prepare students for quality jobs and careers related to CAD/CAM/CNC, a workbook was created. The workbook includes 27 hands-on lessons and projects, student handouts, applied STEM problems and activities, tutorials, drafting standards, state math standards, and equation sheets. The workbook is designed to be used as a resource for CAD/CAM/CNC teachers in Washington State.

TABLE OF CONTENTS

| Chapter | Page |
|---|------|
| I THE PROBLEM | 1 |
| Introduction | 1 |
| Rationale | 2 |
| Scope | 3 |
| Limitations | 4 |
| Definitions and Acronyms | 5 |
| II REVIEW OF THE RELATED LITERATURE | 8 |
| The Evolution of CAD/CAM/CNC | 8 |
| The Manufacturing Industry and CAD/CAM/CNC Use | 11 |
| Benefits of Using CAD/CAM/CNC in the Manufacturing Industry | 20 |
| Demand for CAD/CAM/CNC Operators | 22 |
| Efforts in Providing Skilled Manufacturing Employees | 23 |
| The Need for CAD/CAM/CNC curriculum in Washington State | 26 |
| Effects CAD/CAM/CNC Training Has Had in Schools | 37 |
| Drawbacks of Teaching a CAD/CAM/CNC Curriculum | 40 |
| III METHODOLOGY | 43 |
| Introduction to Methodology | 43 |
| Description of Methodology | 43 |
| IV THE PROJECT | 48 |
| Purpose | 50 |
| Introduction | 51 |
| Laser Engraver Projects | 53 |
| Milling Machine Projects | 135 |
| Appendixes | 219 |
| V SUMMARY | 230 |
| Suggestions for Further Work | 230 |
| REFERENCES | 232 |

CHAPTER I

THE PROBLEM

Introduction

It all started five years ago when the author began his first year of teaching at Kelso High School. He taught five periods of woodshop and one period of computer-aided design (CAD). The CAD program, which he never thought he would teach, consisted of just 16 students. The author did the best he could with the class as he worked through many training manuals and books with his students. While teaching CAD he always tried to make the subject relevant to his students with real world examples and projects. As his comfort level with the subject has grown over time, he has made his curriculum more and more challenging. Now, he teaches three periods of CAD, has three levels of students, and an overflowing program with nearly 150 students signed up for next year. The students are extremely excited about CAD and continuously demand more curricula. To meet their needs the author purchased a computer numerically controlled (CNC) milling machine, a CNC laser engraver, and some computer-aided manufacturing (CAM) software within the last year. The new technology will allow him to advance his program to the next level as CAD/CAM/CNC is being used around the world today in the manufacturing industry. However, more importantly, the technology will allow him to use a hands-on approach in teaching science, technology, engineering, and math (STEM).

In an effort to learn more of the CAD/CAM/CNC technology the author has attended workshops and has done a lot of networking among fellow teachers. He has found there are a lot of teachers using CNC machinery around the state, but in so many different ways. Currently there does not appear to be any CAD/CAM/CNC curriculum directly aligned with Washington State's standards. There are a lot of great text books that teach CAD, but they lack hands-on activities and projects where students can engage in their learning and apply concepts related to STEM. It is believed that student interest and motivation can be piqued through hands on activities (Berry et al., 2005). Therefore, the author has chosen to create a CAD/CAM/CNC curriculum for high school students in the state of Washington.

Rationale

There are many reasons why the author has chosen to create CAD/CAM/CNC curriculum that aligns with Washington State's standards. The main reason is because he is going to start using CAM software and CNC machinery in his CAD classes, but there is no curriculum written to do so. Upon networking the author has found that every teacher who teaches CAD/CAM/CNC has had to create their own assignments and projects for their programs. There does not appear to be many resources available that include CAD/CAM/CNC projects and curriculum. This is a big challenge for teachers who want to add CAM software and a CNC machine into their program.

Many CAD teachers in Washington State use the General Drafting 15.1301 frameworks in their classes. Therefore the author plans to add a CNC component to the assignments and projects within the frameworks to align CAD/CAM/CNC with the state's standards. When he creates the curriculum he will show how science, technology,

engineering, and mathematics (STEM) is taught within a CAD/CAM/CNC class as well. Teaching STEM in a CAD/CAM class would allow students who learn best by doing, to excel because they would be putting theory into practice. Concepts that are tough for some to grasp on paper can be easily understood kinesthetically, touching, manipulating, and thinking (Smith, 2003, p. 35). Being that STEM is increasingly important in education today, the author wants to include the new initiative ideas in the curriculum that are supported in CAD/CAM/CNC classes. The overall goal is to create a rigorous and relevant curriculum that will have a positive impact on student learning in the high school setting.

Scope

The overall scope of the project is to create CAD/CAM/CNC curriculum that can be implemented in classrooms by Career and Technical Education (CTE) teachers in the State of Washington. In effort to support the importance of CTE the curriculum will have Grade Level Expectations (GLE's), Essential Academic Learning Requirements (EALR's), and science, technology, engineering, and math (STEM) incorporated. The author plans to put the curriculum together in a workbook. The workbook is to be used as a resource that teachers can use in their classrooms to help them teach CAD/CAM/CNC. The curriculum will be a starting point for teachers that are teaching in an area that is not their expertise but want to include CAM software and CNC machinery in their program. The workbook will not be intended to replace any CAD/CAM books or manuals. The workbook will provide more of an application focus on real-world problems that align with industry and STEM. Applied mathematics will be incorporated within an assortment of lessons and projects that can be used with many

different types of CNC machines. The author plans to distribute the workbook to CAD/CAM/CNC teachers at the Washington Association for Career and Technical Education (WA-CTE) and Washington Association for Skilled and Technical Sciences (WASTS) conferences in the future.

Limitations

While creating the CAD/CAM/CNC curriculum there were a few limitations that the author was faced with. One of the limitations was the choice of software used to demonstrate the CAD/CAM/CNC assignments and projects. There are so many different types of CAD/CAM software already developed that it would be impossible to create a workbook demonstrating all of the software for each activity. Instead, the author was limited to using the CAD/CAM software available in the lab. The good news is that the software in use for CAD, called RHINO, is very popular in high schools in Washington State. However, the CAM software in the lab, called PartWorks, is not the most popular or best CAM software available for use today. The author was not able to purchase and use one of industry's leading CAM software like MasterCAM because of funding limitations. On the other hand the lessons and projects in the workbook were designed in a generic way so teachers can integrate their machines with the workbook's lessons and projects.

Another major limitation the author had while creating the CAD/CAM/CNC curriculum was having access to CNC machinery. Currently he has two CNC milling machines, a CNC plasma cutter, and a CNC laser engraver at his school. The author does not have access to a vinyl cutter or 3D printer, which he had hoped to include in the workbook. He attended workshops and conferences where he learned how to use CNC

machinery. Learning how to use new software and CNC machines for creating the curriculum was a challenge. However, the author knows that the workbook will pay off as he will be able to use the end product in his program. The workbook is relevant to what he teaches and applies to technology classrooms throughout the state.

Definitions and Acronyms

Adequate Yearly Progress (AYP): the measure in determining whether a school or district is making progress towards the academic goals established by each state (www.k12.wa.us)

College-Readiness Standards for Mathematics- curriculum for grades 11 and 12 that is not designed to prepare students for the state assessment or serve as a remedial course for students who have failed an attempt at the state assessment. (www.k12.wa.us/careertech/formsstandards.aspx)

Computer-aided design (CAD): also referred to as computer-aided drafting, is the use of computer software for designing and drafting applications (Nanfara et al., 2002, p. 364)

Computer-aided design and drafting (CADD): also referred to as CAD (Madsen et al., 2002, p. 15)

Computer-aided engineering (CAE): the use of computers to design, analyze, and manufacture a process or product (Madsen et al., 2007, p. 64)

Computer-aided manufacturing (CAM): the use of computers to assist in various phases of manufacturing (Nanfara et al., 2002, p. 364)

Computer numerical control (CNC): a numerical control system that uses a computer as a controller (Nanfara et al., 2002, p. 365)

Career and Technical Education (CTE)

Essential Academic Learning Requirements (EALR's): standards defined to show what students should know and be able to do at each grade level, result of the Basic Education Act of 1993 (www.k12.wa.us)

Equivalency Course: A CTE course or courses that satisfy one or more academic subject areas that are required for graduation (www.k12.wa.us/careertech/formsstandards.aspx)

Equivalency Credit Toolkit 3.0: a toolkit that is designed as a resource guide for school districts that are trying to implement core academic credit equivalencies for CTE courses in Washington State (www.k12.wa.us/careertech/formsstandards.aspx)

G-code: preparatory functions found in NC code, which involve tool moves (roughing, rapid moves, feed moves, etc.) (Nanfara et al., 2002, p. 37)

General Drafting Frameworks 15.1301: is the curriculum layout of the standards and competencies that one who teaches a general CAD class must teach (www.wasts.us)

Grade Level Expectations (GLE's): standards defined to show what students should know and be able to do at each grade level (www.k12.wa.us)

M-code: miscellaneous functions found in NC code, which are actions necessary for machining but they are not actual tool movements (coolant on/off, spindle on/off, program stops, etc.) (Nanfara et al., 2002, p. 37)

Manufacturing Institute (MI): the education and research branch of NAM (www.nam.org)

National Association of Manufacturers (NAM): an industrial trade association that represents companies in every industrial sector in every state (www.nam.org)

No Child Left Behind (NCLB): an act of 2001 to improve the performance of U.S. primary and secondary schools by increasing the accountability for states and schools (www.k12.wa.us)

Numerical control (NC): the process of controlling a machine by using numbers, letters, and symbols (Nanfara et al., 2002, p. 369)

Science, technology, engineering, and mathematics (STEM): a movement to build cumulative STEM competencies and knowledge in students from elementary school through post secondary education in the areas of science, technology, engineering, and mathematics, with the use of research projects, hands on projects/activities, and open ended or real world problems (Berry et al. 2005)

Three-dimensional (3D): the use of three planes or axis (x,y,z)

Two and one half dimensional (2 ½D): the use of two axis (x,y), with a third axis (z) being fixed, often used for machining pockets

Two-dimensional (2D): the use of two planes or axis, usually x and y axis

Washington Association for Career and Technical Education (WA-ACTE): an affiliated state association that promotes and improves the cause of Career and Technical Education to the state of Washington (www.wa-acte.org)

CHAPTER II

REVIEW OF THE RELATED LITERATURE

The Evolution of CAD/CAM/CNC

Over the past few hundred years drafting has come a long way with the help of advancements in technology. Traditional drafting was done by hand with a pencil or ink. Manual drafters used to use drafting instruments and equipment to draft on either paper or polyester film. In the 1800's Coleman Sellers, who used to take part in manufacturing fire engines, used large blackboards to draw full size parts on. Coleman's son George recalled the time he laid on his belly as his dad stood over him and used his arms to create the radius for curves on some of the sketches he created (Madsen, Madsen, & Turpin, 2007). At that time the sketches were used for patterns to create three dimensional (3D) wooden models. Henry Ford was also very famous for his use of blackboards to sketch car parts. He too had pattern makers construct full-size 3D wooden models from his sketches (Madsen et al., 2007). Today board drafting has been replaced with computer aided design.

Due to advancements in computer technology and software, CAD is used to create two dimensional (2D) drafting and 3D modeling in many industrial applications (Giesecke et al., 2001). Computer-aided design is being used worldwide now in all aspects of drafting, designing, and engineering (Madsen et al., 2007). The software is found within disciplines of architecture, manufacturing, welding, landscape design, pattern making, solid modeling, and much more (Madsen et al., 2007). The use of CAD

has increased the productivity and cost effectiveness of drafting and design work for many companies around the world (Giesecke et al., 2001).

Computer-aided design allows designers and drafters to create 2D drawings exactly like manual drafters once did, but with the use of a computer. The drawings can be created accurately, to various scales, and to meet industry standards (Giesecke et al., 2001). Computer-aided design software allows the user to create information in graphic form, and to also design and store engineering analysis, cost calculations, material lists, and other forms of information (Madsen et al., 2007). Designers and drafters can easily save, edit, and store their designs now when they use CAD. Prior to CAD, editing a drawing took a lot of time and storing the work took a lot of space. Computer-aided design has definitely made drafting and designing a lot easier and more efficient.

Three dimensional designing and modeling is becoming increasingly popular in CAD as well. Many CAD software products allow the user to create 3D surface and solid modeling now. Doing so provides a realistic, accurate presentation of the model as one can add color, texture, lights, shadows, and materials to the model (Madsen et al., 2007). Landscape and architect designers are just a few of the many disciplines in industry that use the 3D presentations to display their designs. Since many people like to see what they are making or purchasing prior to doing so, the 3D surface and solid work in CAD is becoming increasingly popular.

Drawings and models that have been created with CAD can easily be integrated with a CAM software to produce a part. Computer-aided manufacturing software allows one to control the manufacturing data, plans, and operations that are needed in the production process. Parts are designed in CAD and transmitted into a CAM program

where instructions are generated for a CNC machine to run. The user of the CAM program then selects specific tools that are needed and creates toolpaths. Once a CAM programmer has established all the necessary toolpaths to machine the part, it goes to the post processor. There are many post processors so the operator must pick the one meant for the machine he uses, so the correct codes can be sent to the machine. The post processor, which is built into the CAM software, then generates G-code from the toolpaths. As a result, a CNC program is created. The CNC program is a form of code that lists sequential machining operations and different points on a plane. Prior to running the CNC program with a CNC machine, the program is simulated with the CAM software to verify all toolpaths. If the program is correct, then it can be run on the CNC machine needed to manufacture the part (Madsen et al., 2007).

Much like CAD, the use of CNC has changed drastically over the years. The changes occurred during World War II when industrialists realized they could no longer meet quality and quantity requirements at the same time. At the time machinists produced quality parts but not at a high volume. Because of human factors, the quality decreased as the quantity of parts increased (Nanfara, Uccello, & Murphy, 2002). As a result, the first three-axis, numerically controlled (NC), tape-fed machine was created in 1952. The coded paper tape was required to run most of the first generation NC machines (Nanfara et al., 2002). Engineers used to write the NC code needed to operate a machine. The NC code consisted of G-codes and M-codes. The G-codes are preparatory functions that control tool movement. The M-codes are miscellaneous functions needed for machining but are not actual tool movements. Once the NC code was generated, the code was encoded on long strips of paper by patterns of punched

holes. The hole pattern is what the NC machines read and operated from. However, further research and developments in technology have led to the use of CNC machines (Nanfara et al., 2002).

Modern technology has allowed CNC machines to replace NC machines. With CNC technology, programs can easily be edited, run, and stored for further use. As mentioned earlier, the code is now generated in CAM software using a postprocessor. What used to take engineers hours can take the CAM software minutes. Also, in the past if a NC code was incorrect the engineers had to go back through the entire code, find the problem, and regenerate the code. Operators would also have to go back and remake the part because there was no way to simulate the toolpaths on a computer without CAM software. Now, however, if the code is incorrect the CAM programmer can re-open the file on a computer, make the necessary changes, and re-simulate the code to show the machining processes on the computer prior to machining the part. As a result the flexibility of parts that can be produced with CNC machines is much larger now as well. Computer-aided manufacturing software makes generating part programs nearly automatic thus drastically saving manual programming time. Overall, the use of CNC machinery has increased productivity and product quality, while lowering manufacturing costs (Madsen et al., 2007). As a result, many manufacturing companies around the world are switching to CAD/CAM software and CNC machine technology.

The Manufacturing Industry and CAD/CAM/CNC Use

On a global perspective there is some tension in the manufacturing industry. According to Vavra (2007), this is because “wages for manufacturing in emerging economies such as China and India create an unfair advantage” (p. 1). Reports show that

manufacturing jobs being sent overseas have become increasingly common. In fact, a study by Forrest Research found that 3.3 million jobs are expected to be sent overseas by 2015 (Thottam, 2003, p. 2). With CAD/CAM/CNC being used world wide now, the manufacturing industry is becoming more and more competitive. Mahajan (2004) acknowledged the point, “why pay someone \$15 an hour to do something that can be done elsewhere for \$2 an hour” (p. 1). Some United States managers believe that by taking advantage of lower wages overseas they can cut overall costs 25%-40% while building a more secure and focused work force in the U.S. (Thottam, 2003).

Are the lower salaries the only reason U.S. companies are sending jobs overseas? No, according to Conner (2004) many U.S. companies have wanted to increase what they can manufacture within the states but there are not enough engineers to do so (p. 44). As of 2004 the U.S. was only producing about 60,000 engineering graduates a year, while China was producing 220,000. India is forecasted to produce 500,000 engineering graduates by 2010 (Conner, 2004). According to Thottam, the educated Indian workers are the world’s most sought after employee these days (2003).

The U.S. manufacturing companies definitely have their hands full with the competitive industry that manufacturing has become worldwide. Rather than relying on the U.S. or Europe these days, multinational companies are now looking to their native engineers to take on their own design and research tasks in an effort to increase their marketing and manufacturing presence. Globalization is causing a shift in the location of research, design, and development around the world (Conner, 2004). After all, Conner (2004) stated, “in the global economy, the new motto for emerging countries seems to be there’s no need to steal jobs when you can create your own based on a growing economy

and a huge source of well-educated engineers and scientists” (p. 44). It appears that many countries have caught up to the U.S in the manufacturing industry.

One of the major reasons for the increase in global competition within manufacturing is technology. There are more CAD/CAM software companies marketing their software worldwide now than ever before. The use of the internet also has played a roll in the manufacturing industry. The internet allows companies to sub-contract part of a job overseas with a click of a mouse. As a result it is common for a parent company to have multi-national offices around the world (Conner, 2004). Carl Fries, president and CEO of Wright & Sons, explained,

I think opportunities are there for a shop that employs newer and higher-quality technology. Technology will open doors. The name of the game is speed: process parts as fast as possible at the highest level of quality. If we can't do that, we're done, no matter how rich a history the company has. In the past, the Chinese didn't have the technology to compete, but they're acquiring it and getting better at using it.

(“Modernization,” 2007, pp. 48-49)

The U.S. has been known for its production in the manufacturing industry, but now other countries have caught up with the U.S. as technology has evolved.

Things are not looking good for the U.S. in terms of losing jobs to countries overseas in areas such as CAD/CAM/CNC. However, there is a bright spot in global manufacturing; salaries could have a major impact on future outsourcing. According to a study by Towers Perrin Consultancy the base manufacturing wages in China and India are raising faster than the rate of inflation in both countries, and double the base rate in the U.S. (Vavra, 2007). The study showed that in 2008 the manufacturing salaries were

forecasted to raise by 9% in China and 15% in India, which is similar to the increases that took place in 2007 (Vavra, 2007). As a result, Towers Perrin officials see “the competitive wage advantage starting to erode” (Vavra, 2007, p. 1). Ravin Jesuthasan, managing principal and practice leader at Towers Perrin, stated, “you play that forward a few more years, and that cost disadvantage, particularly given the currency depreciation in the U.S. is significantly nullified. You’ll start to see a slow down of work moving to India and China” (Vavra, 2007, p. 2) Though this is only a prediction, it will be very interesting to see what the future holds for the U.S. in the manufacturing industry over time.

Manufacturing jobs in the U.S. have declined slightly from 2004 to present. Employment in the manufacturing industry declined by 2.1% in 2007 and 2.6% in 2008 as the U.S. started to go into a recession. In the 4th quarter of 2008 the U.S. exports showed a 23.6% drop while imports declined 16% (“Washington economic,” 2009, p. 1). Some major contributors to America’s economic troubles have come from the poor housing market, auto sales, and inflated gas prices (“Washington economic,” 2009, p. 4). The construction and manufacturing industries have definitely been impacted as a result. Forecasters predict the unemployment rate in the U.S. to rise over 8% in 2010, which has not occurred since the early 1980’s (“Washington economic,” 2009, p. 7). After all, when the economy struggles and people do not spend money there is less demand for products to be manufactured. This leads to unemployment in the manufacturing industry.

The U.S. manufacturing industry has seen a decline in production and employment for many reasons. Manufacturing companies have reported that the decline in the value of the dollar, higher energy rates, unfavorable exchange rates, drop in

demand, and the increased levels of inflation in Asia have impacted their industry (“Modernization,” 2007, p. 5). The Institute for Supply Management reported that “manufacturers are in a situation where both new orders and production are slowly declining, but prices continue to rise at highly inflationary rates” (“The current,” 2008, p. 5). It appears the U.S. needs to make some changes in order to help the manufacturing industry.

So what is being done in the U.S. to help the manufacturing industry? In 2007 the National Association of Manufacturers (NAM) reported that congress passed legislation that opened 8.3 million acres for developing oil and gas. The goal is to reduce the manufacturers from depending on sources of energy from foreign countries (“Investing,” 2007). The manufacturing industry is also looking to greatly benefit from the federal government’s stimulus package. The \$787 billion package is slated to cut taxes and to create infrastructure jobs for Americans (“Washington economic,” 2009). The creation of infrastructure jobs means more work for manufacturing companies in the U.S. Forecasters predict that with the help of the stimulus package the economy will pick up midway through 2010 (“Washington economic,” 2009).

The manufacturing industry in Washington State has experienced an overall decline in recent years. Washington, which lost nearly 20% of its manufacturing jobs between January 2001 and August 2004, ranked 12th in the nation in 2004 for manufacturing jobs lost (“Washington State,” 2004, p. 2). During that same time the state had lost 66,700 manufacturing jobs. The manufacturing sectors that suffered the most were the aerospace industry, computer and electronic products, food manufacturing, machinery manufacturing, fabricated metal products, paper and wood products, and

primary metals and aluminum products (“Washington State,” 2004, p. 3). The Seattle, Tacoma, and Spokane regions lost most of the manufacturing jobs in Washington with Seattle losing 42,200 while Tacoma and Spokane together lost another 7,000 jobs. Reports showed that over 40% of the manufacturing jobs that were lost in Washington were due to trade (“Washington State,” 2004, p. 3).

Boeing, the state’s leader in aerospace, accounted for over 23,000 of the jobs lost due to trade and import competition (“Washington State,” 2004). In the report, excluding Boeing, there were another 7,177 layoffs examined. Of the 7,177 manufacturing lost jobs, 2,619 of them were trade related (“Washington State,” 2004). The computer and electronic products sector ranked second in manufacturing jobs lost as the sector declined 35% or 12,200 jobs from 2001-2004. The primary metals manufacturing industry lost about 52% of its jobs as did the aluminum industry with a loss of 72% of its jobs. Manufacturers of wood and metal products were also durable good producers that had large losses during the manufacturing crisis. Sectors producing non-durable goods such as food manufacturing, paper manufacturing, and printing and related support all suffered major losses during 2001 as well. Printing and related support took the largest hit, losing about 24% of its jobs. However the food and paper manufacturing sectors lost nearly 10% of its jobs during that time as well (“Washington State,” 2004, p. 5).

To get a better understanding of why large-scale layoffs took place from 2001 to 2004 a Job Export Database Project was created. Project researchers only researched companies in Washington that had more than 100 employees and had laid off at least 50 people (“Washington State,” 2004, p. 6). The report found that of the 41 manufacturing

companies that were researched, 14 of them laid off workers due to import competitions or because their companies were shifting operations overseas.

Boeing reported that the September 11, 2001 attacks had a major impact on a slumping global air travel, and they were also facing import competition from their European-competitor, Airbus. Boeing's decision to move part of its operations overseas threatens thousands of machinists and engineering jobs. As a result, Boeing now employs 350 low-cost Russian aeronautical engineers in a research and development center in Moscow. China and Japan have also been outsourced to make parts for Boeing's 737 jet and work on the company's composite and wing technology ("Washington State," 2004, p. 10).

The aluminum processors in Washington that reported 774 job losses explained that the California electricity crisis that occurred in 2001 raised the electricity prices to a level that forced plants to close and jobs had to be cut back ("Washington State," 2004, p. 10). Aluminum companies across the U.S. also suffered during that time due to poor aluminum sales and costs, while competing with China's aluminum industry. When China expanded the aluminum cost in the U.S. went up and the supply went down ("Washington State," 2004, p. 9).

Washington's paper, pulp, and wood products industries faced major job cuts due to import competition as well. In fact, from January 2001 to May 2004 about 75% of the layoffs in these sectors were due to import competition.

Many of the electronic component manufacturing operations that took place in Washington has shifted overseas as well. For example, AVX Corp., an electronics plant in Vancouver cut 350 jobs and moved to Mexico. In 2001 Matsushita Kotobunki

Electronics Industries of America laid off about half of its workforce in Vancouver and moved the other half to Indonesia. Vancouver was impacted again when the silicon wafer fabricator, SHE, eliminated 350 jobs and moved the plant to Malaysia (“Washington State,” 2004, p. 12).

As mentioned earlier, non-durable goods were impacted during this time in Washington, and the one sector that felt a huge impact was the food manufacturers. Import competition caused Miller Brewing Co. in Tumwater to cut 375 jobs and close their doors. A frozen food company, Agrifrozen Foods in Grandview, had to cut 368 jobs as a result of high electricity prices and competition from China. The frozen foods company has also closed many of its plants and moved them to Mexico (“Washington State,” 2004, p. 10). Selah’s apple producer, Tree Top, has had to make many job cuts due to import competition with China (“Washington State,” 2004, p. 11). There is a report also that East Wenatchee’s Dole Fresh Fruit Co. cut 232 jobs and has shut down plants due to competition with Chinese exports (“Washington State,” 2004, p. 12).

The Job Expert Database Project’s analysis uncovered many trade-related layoffs in Washington State between January 2001 and May 2004. In Washington and other states, U.S. manufacturing companies have seen a drastic drop in employment due to the outsourcing of U.S. jobs and competition from imports (“Washington State,” 2004, p. 12).

Washington State, however, made an economic recovery from 2004 through 2007. The improvement was a result of the improvement in the world economy and the decline in the U.S. dollar (“Washington economic,” 2009). The employment rate went up about 8% from 2004-2007 in Washington. The construction industry led the way with

a 19.4% increase, followed by manufacturing which improved 10.1%, and the service-producing industry saw a 6.5% increase in employment (“Washington economic,” 2009, p. 86). However, the numbers soon fell for Washington’s industries when the U.S. started to go into a recession.

Washington is currently in the middle of a recession that started in 2008. The weakness in the economy has spread throughout many of Washington industries such as construction, manufacturing, aerospace, software publishing and retail sales (“Washington economic,” 2009). Forecasters predict the recession will flatten out toward the end of the 3rd quarter of 2009 and will remain flat through the first half of 2010. The main reason for the poor outlook for Washington’s economy is because of the severe downturn in the national economy which is producing job losses in many industries including manufacturing (“Washington economic,” 2009).

So what is next for Washington? Currently economic and forecast members predict that the Washington economy will pick up midway through 2010 and will increase through the year 2011. The unemployment rate is forecasted to drop in 2011 as manufacturing and construction jobs pick up (“Washington economic,” 2009).

Washington is hoping to use some of the federal government’s stimulus package funds of \$787 billion to create infrastructure jobs as well. Right now it appears that renewable energy is a big focus in Washington. Regardless of the focus, Washingtonians are hoping the state’s high unemployment and poor economy will soon turn around. When the economy does turn around will the manufacturing companies be ready for the work?

Benefits of using CAD/CAM/CNC in the Manufacturing Industry

As previously mentioned, the manufacturing industry within the U.S. is very competitive. Every minute of every day there are parts, molds, assemblies, and much more being produced by manufacturing companies across the U.S. Many of the manufacturing companies that are still around have made the technology jump to stay competitive. Companies are finding that purchasing CAD/CAM software and CNC machinery has increased their success. Fries explained,

A U.S. shop using the same equipment it has been for 20 or 30 years may say ‘The equipment on our shop floor has always worked. It makes the parts, we hold the tolerances, so why invest in new machinery?’ But that won’t cut it anymore. A shop can’t be passive. It has to be active. At the same time, shops go out of business because they’re not employing the latest technology. They’re not willing to make the investment. So, there’s a thinning of the herd. (“Modernization,” 2007, p. 49)

It appears that in order to stay in the manufacturing industry today companies are having to update their facilities by bringing in CAD/CAM software and CNC machinery.

So just what does implementing CAD/CAM/CNC do for a company and how does the technology impact their success? Research shows that modernizing with CAD/CAM/CNC helps prevent bottlenecks in shops and increases part output. The Genesis Mold Corporation of Libertyville, IL has found that using CAD/CAM software has allowed their operators to start cutting molds in two hours rather than two days (“Mold maker,” 2006, p. 45). Another company, Twin Disc, has experienced a 30 to 40 percent decrease in cycle times on some of the parts they produce which comes from reduced setups and faster feed rates (“From bottleneck,” 2008, p. 30). Being able to

increase in production has allowed some companies to take on work they once had to turn down because of extremely aggressive timelines (“Mold maker,” 2006). For example, previous methods of manufacturing such as manual machining only allowed for a machinist to run one machine at a time. However, running CNC machines allow for companies to have one operator run multiple machines at once with much quicker feed rates (“From bottleneck,” 2008). Turn-around is also quick because of the use of computers. Part files are saved on a computer so going back and changing a design is very easy for companies who use CAD/CAM (“Mold maker,” 2006). What used to be a timely process of literally going back to the drawing board to refigure a part or toolpath can now be done with a few clicks of a mouse.

As a result of CAD/CAM/CNC, the quality of products produced in America has greatly increased. Manufacturers are able to create products to greater precision consistently. Once a part is designed in CAD and toolpaths are programmed in CAM an operator can run the same part over and over with the same precision. Manual machining in the past was a precise way to machine parts but to be efficient and machine multiple parts with the same tolerances was very difficult to do. Therefore, to ensure quality at a high production rate CAD/CAM/CNC is a must have for companies in the manufacturing industry.

Much like what is happening internationally, there are a lot of manufacturing companies in the U.S. that are subcontracting some of their CAD/CAM work within the states. In the manufacturing industry the use of CAD/CAM software and CNC machinery is becoming the norm and a must have to stay in business. Danny Odom, president of Aero Components Inc. explained that in the medical industry “the only way

you can survive is obtaining productivity through technology” (“Technology,” 2006, p. 14). With the increased use of technology the manufacturing industry is becoming very competitive.

Demand for CAD/CAM/CNC Operators

It appears that as time goes on the manufacturing industry is becoming more and more competitive. As mentioned earlier, in order for many companies to stay in business they have had to implement the use of technology with CAD/CAM software and CNC machines. As a result, CAD/CAM/CNC is the foundation of most of the work that is being done in business shops and contract manufacturers today (“Prepping,” 2008). However, in order for a company to take advantage of CAD/CAM/CNC they must find skilled workers who know how to use the technology.

As businesses switch to using the CAD/CAM/CNC technology in their companies one of the major problems they are having is finding workers who are qualified to run the software and operate the machinery. A few years back several cabinet shop owners in Ohio went to a local teacher at a technical school and said they were unable to take advantage of running CNC machines in their shops because they could not find people who could program the machinery. As a result the teacher implemented a CNC curriculum into his construction program and the five local cabinet shops purchased CNC machines for their newly trained students to operate. This is just one of many examples of how there is a shortage of highly skilled workers that know how to use CAD/CAM software or operate a CNC machine. One of the cabinet shop owners stated that “most of us don’t want to take time to learn about computers and are too busy to stop overseeing our shops to learn” (Panella, 2007, p. 12). This statement brings up another reason why

CNC operators are in such high demand. It is due to the age of many workers in the manufacturing industry.

Most employees in the manufacturing industry are baby boomers and they will be either retiring in the near future or will be driven out of the industry due to the technology. One of the number one goals in the U.S. and within the National Association of Manufacturers (NAM) is to replace the baby boomers with a skilled workforce. Currently there is a shortage of skilled workers coming out of the U.S. education system so the U.S. plans to improve the quality of education to create the skilled workforce that is needed ("The DNA," 2008, p. 16).

Efforts in Providing Skilled Manufacturing Employees

To provide manufacturing companies with highly skilled workers, the NAM believes the U.S. must first improve the quality of education at all levels. They also feel that a better job needs to be done with job training programs to address the continuous demands of training and retraining of workers ("The DNA," 2008, p. 16). In an attempt to produce the necessary workers for the future, a Dream It-Do It campaign and the implementation of STEM have been put into place.

The Dream It-Do It campaign, which started in Kansas City during 2005, has now spread across 15 states. The campaign originated after NAM kept hearing from manufacturing members that they were struggling to attract employees with skills. One of the primary goals for the campaign is to link manufacturing and education together. The goal is to raise the awareness of students about career opportunities in manufacturing. Students will learn about the requirements they should take in high

school or post-secondary to help them prepare for a career of interest (“The DNA,” 2008).

The Manufacturing Institute (MI) has now posted a Dream It-Do It website where one can go to learn about the campaign. The website has links set up for people to take career quizzes, learn about career profiles, and search schools related to careers of interest. Some links have also been set up for parents, educators, employees, and sponsors/partners to view and show information about the campaign. The parent link is especially important as NAM wants parents to be educated about how the manufacturing industry has changed in hopes of eliminating the stereotypes some may have about manufacturing jobs. Educators are encouraged to go to the site to display the careers and options to their students and parents. The website also has a link that takes viewers to the different regions in the U.S. where the campaign is taking place. The site displays the names of those involved in the region and any events or related information that is taking place. It is important to note that Washington is one of the 15 states to join the campaign.

Though Washington is actively involved with the Dream It-Do It campaign, the state is just getting started with a STEM initiative. The STEM movement is a push for the integration of science, technology, engineering, and mathematics instruction (Berry et al., 2005). The STEM initiative has surfaced because national business and political leaders are worried about the “U.S. schools’ ability to stimulate students’ interest in math and science” (Honawar, 2005, p. 1). This is an area of weakness people believe has led to the growth of Asian countries in the fields of engineering and technology. According to the Trends in International Mathematics and Science Study, American high school students are being outperformed by students in other developed countries. In 2008 there

were 60,000 engineers produced in the U.S., compared to a million engineers in China. As a result, in July of 2009 the U.S. is creating an action plan to increase student achievement in science, technology, engineering, and math. The goal of the plan is to double the number of engineering graduates in the U.S. in the next 10 years (Honawar, 2005, p. 3).

How exactly are teachers supposed to implement STEM? Though STEM is a work in progress it is believed that programs should build cumulative STEM competencies and knowledge in students from elementary school through post secondary education. Teachers should also provide students with research projects, hands-on projects or activities, and open-ended or real world problems for students to solve. Again, all of the above activities should incorporate science, technology, engineering, and math (Berry et al., 2005). It is believed that STEM is “a unique way to map curriculum and attempt to build and strengthen student skills in those subjects that can lead to scientific and technological career pursuits” (Berry et al., 2005, p. 24). The various hands-on activities and projects can increase student knowledge and interest in science, technology, engineering, and math because they use so many different intelligences. It is predicted that students should gain more knowledge by doing STEM curriculum and the knowledge should be transferred among other subjects and applications (Berry et al., 2005).

In Washington there is a STEM initiative. The initiative is for the K-12 education system and is aimed at improving both teacher effectiveness and student learning. There are high hopes on getting many more students ready for college, work, and STEM degree programs. Every student should benefit from STEM in Washington, with a special

interest on increasing the achievement of minority and low-income students. The state plans on building a STEM Center by Spring of 2010 that will provide the talent and resources necessary to help teachers be effective teaching STEM across the state (“Washington STEM,” 2009).

The Need for CAD/CAM/CNC Curriculum in Washington State

Within the manufacturing industry there appears to be a common problem among many companies. The problem often heard in the industry is that companies cannot find anyone who is skilled to operate their CNC machines. This is very sad as an entire company’s success could be resting on the output of one machine or one operator. It is time to fill that void and create a CAD/CAM/CNC curriculum for high school teachers in Washington so the teachers can train a skilled workforce.

One of the many reasons for creating the CAD/CAM/CNC curriculum is to teach students skills that will make them skilled and employable. The Mazak Corporation reported “we have growing pains, the biggest of which is finding people. Also with just in time manufacturing we have more work, but less time to train people to do the work” (“Technology,” 2006, p. 15). There is no reason why such training could not take place in a high school classroom. After all, the role of a CTE teacher is to better prepare students for careers, whether they are going on to post-secondary education or going out in the workforce after graduating high school. Teaching CAD/CAM/CNC curriculum is a way to provide students with some skills that will make them employable. After all, not all high school students are going to college.

A CAD/CAM/CNC curriculum would definitely tie in nicely with the Dream It-Do It campaign. It is a given that most students will not be a CNC operator in the future.

However, the curriculum would allow students to see how CAD/CAM is being used around the world. They may gain an interest in architecture, construction, engineering, interior designing, mold making, and many more trades in industry. Again, the exposure to all the different careers and fields that use CAD/CAM/CNC is one of the benefits of teaching such a curriculum.

The curriculum to be developed would meet the expectations of the STEM project as well. One of the biggest buzz words with STEM is hands on. A CAD/CAM/CNC curriculum is full of hands on activities and projects. It is believed that student interest and motivation can be piqued through hands on activities (Berry et al., 2005).

Teaching STEM in a CAD/CAM class would allow students who learn best by “doing” to excel because they would be putting theory into practice. Concepts that are tough for some to grasp on paper can be easily understood kinesthetically, touching, manipulating, and thinking (Smith, 2003, p. 35). High school CTE teacher, Steve Smith, notes that “finding out how things work through designing, testing and building is at the heart of what stimulates the mind of young engineers to be, spurring these students to become engineers for life” (Smith, 2003, p. 35). Smith also mentioned that “hands-on work captivates the students and holds their attention in a way that book learning cannot duplicate” (Smith, 2003, p. 35). The hands on training received with a CAD/CAM/CNC curriculum would definitely have a positive influence on the learning of many students.

Not only will the curriculum be hands-on, but it will also contain many real world problem solving experiences. Implementing real world problems would make learning more relevant for students. With the use of relevancy the students will be able to comprehend math and science in a way that they can remember in the future. For

example, some people argue that if a student was to study for a math test, they would learn the concepts necessary to take the test, but the information would soon be lost.

High school teacher Richard Filsinger stated that,

Some students studied for their Geometry I test and promptly forgot the basic relationships of diameter vs. radius, how to read a ruler, parallel vs. perpendicular, and even what perpendicular means. They have forgotten because they weren't shown its relevance to real life. They studied Algebra II only so they could pass the state-test, and on and on. But when they must remember the material in order to complete a practical project, it sticks with them. (Millson, 2002, p. 20)

Teaching STEM within a CAD/CAM/CNC curriculum will increase student retention of subject matter with the use of real world, practical math and science problems.

A CAD/CAM/CNC curriculum is an affective way to teach math and science to students because it is built into the course work. The math used in such a curriculum is endless and real. For example, let us say a project is to have each student draw up a 12" ruler, with one edge being standard and the other edge being metric. When the students were done drawing the ruler they would then use a laser engraver to cut their rulers out. The students would need to use their ruler for all of their assignments and measuring in the class. If a student made a ruler that was wrong, then all of their measurements would be off, effecting their assignments. However, in order to make a ruler, the student must think about how to break an inch into 16ths. They must figure out the decimal equivalency for 1 millimeter so they can make the metric ruler. Often times the metric system is skipped over but now the student must figure out how many millimeters are in 1 centimeter, and how many there are in 12 inches. These are just a few math concepts

students would be faced with when creating a ruler project using CAD. Needless to say there is a lot of math being used and the students must problem-solve and possibly use technology such as the internet to do some research. By assigning projects like this the students are in charge of their own learning. Being that they get to cut their own ruler out with their name on it and must use it for the class makes it relevant and motivates them more to learn.

Not a day goes by when math is not being used in a CAD/CAM/CNC class. In typical math classes students usually just learn theoretical math but in CAD/CAM/CNC classes the theoretical math becomes practical (Millson, 2002). A great example of this would occur if a student went to set up their toolpaths and tried to cut out their project using a CNC machine. First, in order to do so the student would have to use CAM software to calculate speed and feed rates depending on the size of the cutter used and type of material they were using. The students must also program the toolpaths around jigs, fixtures, or fasteners that may be holding the project to the work table. The math would get incredibly tricky if the student had to cut out a male part that must fit within thousands of an inch of the female part. However, within a CAD/CAM/CNC class, there is a lot that can go wrong if a student's math is wrong. First of all, the student may cut too deep in one pass, cut too fast, or run the cutter into something. All of the previous miscalculations could result in a broken bit or poor part. The student may have just ruined a cutter worth between \$15 and a few hundred dollars. They may have also destroyed a project they had contributed countless hours into. These are just a few of many scenarios that could occur when operating a CNC machine. The math becomes really relevant when there are big consequences.

Courses such as CAD/CAM teach students a lot about science and engineering with the use of computer-aided engineering (CAE) software. For example, a student could use CAE software like SolidWorks to draw a catapult and test its performance. CAE software is a CAD software with engineering tools built in to run a test analysis on parts. A program like SolidWorks would show a student how far the object being projected would go and where the stress would occur on their catapult. A student could then design a catapult until they were happy with their results. They then could analyze the pros and cons of their design and learn what materials and designs worked the best. After talking with a few teachers in the state that use CAE software in their CAD/CAM programs, it is apparent that the new generation of students get excited about designing and engineering projects when they use CAE software.

Science is a subject area that is weaved into CAD/CAM/CNC classes in many ways. All CAD projects that involve gears, cams, and pulley systems include physics. Science also comes into play when a student uses a CNC machine. Prior to students cutting out a project using such a machine they must know the properties of the material they are using. For example, the hardness of the material effects the cutting speeds. Also, if a student was to cut metal with a CNC machine they would need to know about thermodynamics to determine how much coolant flow to use (Millson, 2002).

Students use science and engineering when they do design projects with CAD software as well. For example, if a student was assigned to design a deck for a house they must again know the material they are going to use. The properties of the material would determine the joist spacing that could be used in the design. If the deck was to be built out of Cedar the spacing could be 24" on center, but with composite decking the

spacing must be 16" on center or less. This is just one of many examples of how science plays a major part in design projects.

Science occurs in a CAD/CAM/CNC class when mold making is implemented as well. A CAD/CAM class is a great fit for teaching mold making. One reason is it introduces students to the huge mold making industry that exists. Another reason is because some mold making companies use CAD/CAM/CNC to make their molds, which they use to cast. An easy and safe way to teach mold making is with the use of silicone and resin. The students would learn a lot of math and science in a mold making unit. Students must first build a box to place their part and pour silicone in. They then must replace their part and pour resin into the silicone to reproduce their original part. However, students must mix both the silicone and resin to specific ratios in order for the material to set up. A miscalculation could lead to part failure and most of all, a fire. The student must wait for their materials to cure prior to removal or they again will have a defective part. It is also important that students calculate the volume of silicone and resin needed to pour each time because the materials used are not cheap. In essence, mold making would be a great hands-on way to teach math and science within a CAD/CAM/CNC class.

Technology plays a key role in a CAD/CAM/CNC class as well. Students use computers most days when they take a CAD class. The technology that can be found in CAD programs does vary. Some schools still use outdated software due to the expense of updating. On the other hand, there are schools across the state that have computer labs equipped with the top of the line CAD and CAM software as they try to align with industry. There are many labs now that are equipped with CNC machines as well. The

technology used with CNC is very high tech. Schools are using CNC with mills, lathes, laser engravers, plasma cutters, vinyl cutters, and 3D printers. Students that take CAD/CAM/CNC classes learn a lot about technology as they work with the CAD/CAM programs and possibly CNC machines. Fortunately, some students get the luxury of learning how to use some of the newest, high-tech software and machinery used in today's industry. The more students learn about the technology and its place in industry, the more employable they will be.

Teaching CAD/CAM/CNC is an excellent way to teach technical reading and writing. Students learn how to use CAD/CAM software by reading technical manuals. They also must read technical manuals to learn how to program a CNC machine. According to Willard Daggett, president and founder of International Center for Leadership in Education, learning how to read such material is vital in today's workplace. Daggett stated,

The reading level for entry-level workers today- because they have to read a manual- is substantively higher than the reading requirements in virtually any academic course you'll take in high school or in college. And not only are the reading skills higher, but if the worker cannot read the materials, the consequences are huge. ("An interview," 2008, p. 12)

Daggett noted that you would not want a person putting brakes on your car who could not read the manual to do so and you would not want an electrician wiring your house if they could not read the manual ("An interview," 2008). He also makes it very clear that technical reading and writing is rarely taught in the U.S. today. Daggett said,

The reality of it is, we either have to compete against high skills or low wages, and we

surely aren't able to compete against the low wages found in other nations. The problem is, we're not yet high-skilled in these new jobs either, because our graduates are functionally illiterate. They are well educated, they are nice people, they are bright, but how many recent college graduates can program a VCR? (O'Neil, 1995, p. 46)

Reading technical manuals in a CAD/CAM/CNC class builds the skills that Daggett is talking about.

Typically language arts curriculum in the U.S. focuses on developing students' personal response to literature and conceptualization skills. Therefore students read literature, newspapers, and many similar materials instead of detailed, technical material (O'Neil, 1995). However, a study Daggett was a part of showed many other countries demanded technical reading and writing in elementary and secondary schools. The results showed that it is not the language arts curriculum that implements such skills. Technical reading and writing is being implemented in the math and science curriculum around the world(O'Neil, 1995). Daggett felt that this is an important distinction to make as he feels that after looking into the language arts programs among many countries, the U.S. appears to be one of the best in the world. He also feels technical reading and writing needs to be taught in science, math, and CTE classes. This proves that a CTE course such as CAD/CAM/CNC is exactly where technical reading and writing can and should be developed.

Implementing a CAD/CAM/CNC curriculum could have a major impact on the survival of a CTE program. Currently CTE programs are under pressure because of No Child Left Behind's Adequate Yearly Progress (AYP). The education system wants to

raise the proficiency of all students, which means CTE programs must be able to demonstrate academic proficiencies on state tests (Daggett, 2005). A CAD/CAM/CNC course that contains a rigorous and relevant curriculum, and aligns with both state and national standards can do just that. According to Daggett, “the 30 highest performing U.S. high schools have organized themselves around small learning communities in the area of CTE” (“Educational rigor,” 2005, p. 36). It is now important that CTE programs can prove to officials that their programs are contributing to both academics and the workplace (“Educational rigor,” 2005). Daggett concluded,

CTE is not just an alternative for students who may choose not to go directly to college. Rather it is the platform, the spine and the instructional basis for developing academic skills for student success on the state tests and in life. (Daggett, 2005, pp. 57-58)

A CAD/CAM/CNC class has the potential to excite and connect all students to learning. Whether it is the 2D geometry or 3D model drawn on one’s screen, the sound of material being shredded by a cutter on a CNC machine, the colored plot of one’s dream house, or the smell coming from the resin that is curing in a mold, there is a lot students can do and learn with such curriculum. There are activities and projects that one could do with CAD/CAM/CNC to get students involved in learning regardless of their gender, race, or culture. Such exposure may lead to more women and minorities going into degrees earned in the area of math, science, or engineering. Daggett mentioned that “we have not provided adequate career awareness and preparation with women and/or minorities. We need to nurture their interests earlier in math and science topics” (“Educational rigor,” 2005, p. 35). It is worth noting that many of the training manuals

that are used to learn CAD/CAM software are available in many different languages, so implementing English language learning students into a CAD/CAM class is rather seamless. Poor students also have a chance to shine in CAD/CAM/CNC classes. Again Daggett notes, “some of the students we classify as poor students do as well or better when the content combines theory and applications” (O’Neil, 1995, p. 47). A teacher in Miami, FL told a story about an attention deficit disorder (ADD) student that could not concentrate because he was so hyper. The teacher introduced the student to a CO2 car project where he had to use CAD/CAM/CNC to draw up and cut the car out using a CNC machine. The student ended up going in after school regularly once he developed an interest in using the technology. Needless to say, the student went off to college in hopes of receiving an engineering degree (Baltazar & Millson, 1999). In essence, a CAD/CAM/CNC class has a lot to offer to all students.

A CAD/CAM class can use CNC technology to help special education students learn as well. In Hialeah, FL a technology educator teaches CAD/CAM to his special education students. Teacher, Jeff Lintz, stated,

I have had many students who clearly had talent in graphics and design that went unrealized because of their physical disabilities. I have seen students with an enormous amount of creativity get frustrated and withdraw because they could not physically build what their minds could conceive. (Lintz, 2004, p. 19)

However, using CAD/CAM software allowed Lintz’s students to define their ideas on the computer and cut out functional projects. Lintz noted, “instead of having to rely on others to produce their designs, they can compete on an equal basis with fellow students, using the CNC machine to substitute for a lack of fine motor control” (Lintz, 2004, p.

20). The Florida teacher said he has seen a lot of pride on his students' faces and sees his disabled students being treated more equal, with less attention being paid to their disabilities (Lintz, 2004). It is apparent that CAD/CAM/CNC/ curriculum can greatly benefit students with disabilities.

A CAD/CAM/CNC class has the potential to grab the interest of a student who is not going to college. Reality is, a lot of high school students dislike school and cannot wait to be done. College is probably not the best option for such a student. Daggett feels that it makes no sense to assume going to college will lead to a good job because just one out of five students obtain a college degree (O'Neil, 1995, p. 47). Again, a CAD/CAM/CNC class is one of the CTE classes that could open a door of opportunity for a student who did not want to go to college. The job of a CTE teacher is to prepare their students for careers. The careers may require students to go to college while others may not. The bottom line is, according to Monster and Craigslist there are a lot of jobs out in industry that use CAD/CAM/CNC every day, and occasionally a student from a CAD/CAM/CNC class will land one of those jobs. When that happens the CTE teacher has done their job.

Another feature of CAD/CAM/CNC curriculum is its ability to be used across the curriculum. Students in physics class can pair up with CAD students and design a catapult together. The same can be said for math. A math teacher may be doing a unit on measuring. They may pair math students up with CAD students. The students then draw a ruler and cut out the ruler using a CNC machine. Also, a construction teacher could pair his students up with CAD students to design storage sheds. The students present their designs and the class builds the sheds for a service project for their district. All of

the above are just a few examples of the many ways CAD/CAM/CNC can be used across the curriculum. By working in teams, the students are developing appropriate social skills needed to succeed in the real world. These activities would again show relevance to real life and the practical projects would help students retain information (Millson, 2002).

A CAD/CAM/CNC class has potential for teaching leadership to students as well. Each class could have a club or student led organization built within it. The club then could do fundraisers with the use of their CNC machine. For example, if a class had a laser engraver they could make protractors, rulers, and other measuring devices so they could sell them in the student store or library. Also, if a class had a milling machine they could make name plates for people who wanted them. If a class had a vinyl cutter they could make stickers for the local youth sports teams. The students would be in charge of all orders and inventory for all the above fundraising ideas. A teacher could use CAD/CAM/CNC to teach leadership in so many ways. This is very important as CTE teachers in Washington are required to have leadership built into their curriculum. In a CAD/CAM/CNC class this would be a seamless process.

Effects CAD/CAM/CNC Training Has Had in Schools

Currently there are CAD/CAM/CNC classes being taught in colleges, technical schools, high schools, and even some middle schools across the U.S. Such classes have had a major impact on student success in academics. At the post secondary level it appears most CAD/CAM/CNC courses are called manufacturing technology. Research shows the manufacturing technology courses are being taught at community and technical colleges. Many colleges teach manufacturing classes, but a lot teach just

manual machining and have not made the shift to using CNC machines. Cape Fear Community College (CFCC) in Wilmington, NC nearly lost their machining program prior to making the switch. The program was down to five students and when they switched from traditional machining operations to CNC programming their enrollment went up to 55 students in one year. They are looking to expand in the future (Cassola, 2006). One of the instructors at CFCC, Randy Johnson, stated that “everyone wants CNC-qualified people” (Cassola, 2006, p. 36).

At Moraine Park Technical College in Kewaskum, WI the machining technology program trains over 200 hundred full-time equivalent students per year while providing continuing education for those in the existing workforce. Instructor Jim Hokenson said, “local industry is very, very happy with what we’ve done. As for the placement rate of the graduating students, all of our students are employed well before the last month of their tour here” (Reese, 2005, p. 43). Hokenson’s statement displays the need for CNC operators in the manufacturing industry. It shows that a good CAD/CAM/CNC program has the potential to produce students that are highly employable when they leave the program.

At the high school level there are a lot of success stories with programs teaching CAD/CAM/CNC. In Aurora, OR, teacher Joe Shephard explained, “in the past few years, we’ve been sending kids out whose CAM skills surpass their supervisors’ because I stay up on the latest capabilities, they fit right into the job market” (Millson, 2003, p. 25). Two of Shephard’s graduates, who interned at a Portland aerospace company after one year at Oregon Institute of Technology were hired as staff programmers within their first 2 months of being with the company. One intern was offered a six figure contract to

be the company's lead programmer, but declined to focus on his studies (Millson, 2003). This again shows that a CAD/CAM/CNC program that is current with technology and demands of the industry can offer quality employment opportunities.

In Washington there is one CAD/CAM/CNC program that is well known, and that program can be found at Mark Morris High School. The Longview program, which just placed second at the SkillsUSA National Competition, has been successful for quite some time. Mark Morris students have placed first in the state eight times and have been to nationals seven times in the past decade. Mark Morris instructors believe that Washington is behind times with CAD/CAM/CNC in schools because there is insufficient money and the education system puts no value on training for industry. However, a source within the CAD/CAM/CNC program at Mark Morris said that many of the students who have left the program have gone on to have success in the manufacturing industry or with post-secondary education. One student was offered a job with Boeing prior to graduating from high school. A few students have even gone to Portland and helped start up successful manufacturing businesses. Several of the students who have left Mark Morris's CAD/CAM/CNC program have gone on to receive degrees in engineering, architecture, or drafting, as the skills learned in the CAD/CAM/CNC class are transferable. The success at Mark Morris High School proves that with a quality, rigorous CAD/CAM/CNC curriculum students can successfully enter the manufacturing industry at an early age. The course work has also given students the success they need to further their education.

It seems that CAD/CAM/CNC is being taught a little more now as programs are adding CNC to meet industry's needs. However, there are very few college programs

that offer a certificate for such training in the U.S. After researching 71 private, public, and community colleges in Washington there appears to be just 10 colleges that offer CNC training. The five community colleges that offer CNC training are Clark, Green River, Lower Columbia, Shoreline, and Spokane. Meanwhile CNC training is available at Bates, Clover Park, Lake Washington, Perry, and Renton technical colleges as well. Students receive a Certificate of Proficiency (COP) for their CNC training at these colleges. However, according to Mark Morris's CAD/CAM/CNC program, proficiency can be taught at the high school level with a rigorous and relevant curriculum. The author's goal is to develop a CAD/CAM/CNC high school curriculum for Washington State.

Drawbacks of Teaching a CAD/CAM/CNC Curriculum

As with most things, there are a few negative factors that limit a CAD/CAM/CNC curriculum being taught in Washington CTE programs. One of the major problems with teaching the curriculum is the cost that is required. The CAD/CAM software and CNC machines are expensive for a program. In order to stay current with industry, programs have to keep upgrading their software. However, in order to continue to run the software the computers must occasionally be upgraded as well. Upgrading a computer lab to teach CAD/CAM/CNC is a continuous cycle.

With funding in Washington's education system being scarce, running a CAD/CAM/CNC program may not be a priority. However, if a district were to shop around they could find some CAD/CAM software and CNC machinery that are affordable. For example, a CAD teacher could spend about \$1,000 for Rhino or \$30,000 for AutoCAD to teach CAD in their lab. Also, a teacher could spend anywhere from

\$1,000 to over \$100,000 on a CNC machine. The smaller, less expensive CNC machines may not be as durable or efficient as some of the larger machines, but they can be affordable and a great start to a CAD/CAM/CNC program. One CNC machine allows a program to do a lot more than no CNC machine. According to Mark Morris's CAD/CAM/CNC program, once students start to see and use the technology it is likely the program will grow. This in turn could bring in more funding for the program.

William Daggett said that school officials,

may be surprised to discover that the programs that are expensive and not highly valued at the secondary school level have the greatest financial benefits for the students and society (ie., many students graduating from career and technical education (CTE) programs end up with jobs beyond entry-level status. Whereas, college students often find themselves functionally unemployable). Ultimately, it becomes an issue of pay now or pay later. ("Educational rigor," 2005, pp.34-35)

There are grants available that CAD/CAM/CNC teachers could apply for. While the cost of running a CAD/CAM/CNC program is high the education experience for students who go through such a program is priceless.

Another drawback to a CAD/CAM/CNC program is the fact that manual machining is unused and students learn to rely on technology. If a computer was to crash the student would not know how to make the part they were going to machine with a CNC machine. However, a student who knows how to do manual machining would still be able to produce the part without using technology. So relying on CAD/CAM software to be able to design and cut a part is not always a good thing, especially if the technology was to fail.

One last major drawback of teaching a CAD/CAM/CNC curriculum is the fact that a high percentage of CTE teachers are nearing retirement and they do not want to learn how to teach with the new technology. Many of the older generation CTE teachers would much rather teach board drafting and manual machining as the thought of teaching CAD/CAM/CNC is overwhelming. Staying current with the technology used in a CAD/CAM class is a lot of work for any teacher because the software and CNC machines are always changing and programs keep evolving (Reese, 2005). A CNC instructor at Moraine Park Technical College, Jim Hokerson, explained that “the equipment is better, the tooling is better, the machine itself is better, and they are all evolving at an incredible rate” (Reese, 2005, p. 43). Though teaching CAD/CAM/CNC requires a lot of work, the payoff of better preparing students for careers is worth the effort.

CHAPTER III

METHODOLOGY

Introduction to Methodology

Enough has been said about the need for a rigor and relevant CAD/CAM/CNC curriculum in Washington State. The author has created curriculum that aligns with state standards and meets the requirements for the General Drafting 15.1301 frameworks for Washington. The curriculum includes many hands-on lessons and projects that incorporate a lot of STEM. The author's overall goal for the workbook is to provide CAD/CAM teachers with curriculum they can use in their classroom.

The reason for the creation of the workbook was not to tell teachers how to do their jobs, but instead to provide teachers with a resource they can use in their classrooms to help them do their jobs. The workbook includes documentation of EALR's and GLE's to help support CAD/CAM teacher's case in their efforts to teach the skills and knowledge needed to help raise AYP. The author created a workbook that has a chapter on laser engraver projects and milling machine projects. Overall, this author hopes the workbook will provide CAD/CAM teachers with lessons and project ideas they can use to incorporate science, technology, engineering, and math.

Description of Methodology

The author started creating the workbook by focusing on CAD drawings and assignments. The reason CAD was the starting point for the projects is because one must be able to draw before they can use CAM. The assignments created for CAD primarily

focused on 2D geometry and measurement, which students struggle with. The idea behind the CAD assignments is to add in activities that can build on students' CAD, math, and science skills.

There are a lot of CAD books out that focus primarily on CAD terminology, commands, and drawing techniques. The CAD assignments in the workbook are directed more towards real world CAD applications and concepts. To do this the author looked at the CAD work that is being done in industry, and used some of the real-world CAD problems in the workbook. By teaching the practical math and science activities students will be able to make sense of the theoretical math and science concepts they have learned in previous classes. The assignments in the workbook will also help students familiarize themselves with CAD commands and concepts. To help make the curriculum relevant each assignment has some kind of project that the student can print or cut out with a CNC machine. Students leaving class with a project in their hand is a common theme throughout the workbook. The author feels that when a student gets the opportunity to make something the learning becomes more meaningful.

It is important to note that the CAD assignments are not designed to teach CAD thoroughly and to be used every day of a quarter. The assignments or projects are to be used when a teacher sees a parallel in the curriculum they teach and are looking for a hands-on approach to teaching the curriculum. Again, there are a lot of great CAD books out there for teachers to utilize. However, the author feels there are not very many real-world application problems and hands-on assignments in the CAD books for teachers to use, and that is what the CAD assignments in the workbook provide.

The CAM projects are a component of the CAD projects in the workbook. The beginning CAM projects focus on teaching G&M code to students. To do this, students must first graph specified projects. Students then use G&M code to cut out their projects using a CNC machine. The G&M code is an important concept to teach students prior to teaching CAM software because that way students develop an understanding of the code or language that takes place when a part is cut. By knowing this a student can fix poor code or write code if they ever need to when doing CAM and CNC work. Unfortunately the CAM software today writes the codes for you so often that being able to read what the code actually means is skipped over. The problem with not knowing G&M code is if there is an error or problem with a toolpath that has been calculated the person has no clue how to fix it or what the problem is. By teaching G&M code the students become familiar with x,y, and z axis, graphing, coordinate system, and much more. Students are also introduced to CNC terminology and set-up like feed and speed rates, tool specifications and parameters, safety and much more. For many students the G&M code assignments will be the first time they have ever machined the math they graphed which is a great experience. The unit on G&M code comes with graph paper and hand outs to make teaching the code a seamless process.

The CAM assignments also include an assortment of projects to run toolpaths on and cut using CAM software and different CNC machines. Much like the CAD assignments, the CAM assignments were not designed to teach CAM software, but instead how to apply the software to real world problems. Again, CAM software companies already have training manuals available to teach how their software is used. The CAM assignments start out simple with 2 ½D toolpaths. As one works through the

workbook they will be faced with more complex 3D models that will require 3D toolpaths. Towards the end of the CAM projects there are a few assignments that involve part indexing as the parts will need to be cut on four sides. The students are challenged with the concept of design for manufacturability and must also think about making jigs and fixtures in order to accurately machine the part.

Once all of the CAD/CAM/CNC projects were created the author went back through each project and added in STEM related questions and activities to help reinforce and see the importance of science, technology, engineering, and math at work. To do so the author had many CTE, and a few math teachers look over the projects and the standards for mathematics. Using the advice from his colleagues, the author created STEM questions for each project. The goal of doing so was to be able to teach enough math within the workbook in effort to provide programs with a math course equivalency. Again, the class of 2013 needs to have three math credits, and so students are going to be pulled out of CTE courses for remediation if they do not pass the state test. However, by teaching enough math within the workbook curriculum CAD/CAM/CNC teachers will be able to provide their students with a math credit and save their student enrollment. To help describe the curriculum and standards alignment the author provided a table at the end of the workbook that breaks down each project and how it aligns within the standards and frameworks. In essence, the workbook that has been created will help support CAD/CAM/CNC programs in Washington State.

In reality there are a lot of CAD/CAM/CNC teachers doing some great things within their programs. Unfortunately there is no CAD/CAM/CNC workbook or resource out there that one can use in their class that contains real-world problems, aligns with

state standards, and meets the requirements for the General Drafting 15.1301 frameworks for Washington. The author feels it is a pleasure to create such a document. He looks forward to presenting and distributing his findings and work to others across the state. The author plans to do this in the near future at the spring and summer WITEA and WASTS conferences.

CHAPTER IV
THE PROJECT

A CAD/CAM/CNC WORKBOOK FOR
HIGH SCHOOL STUDENTS

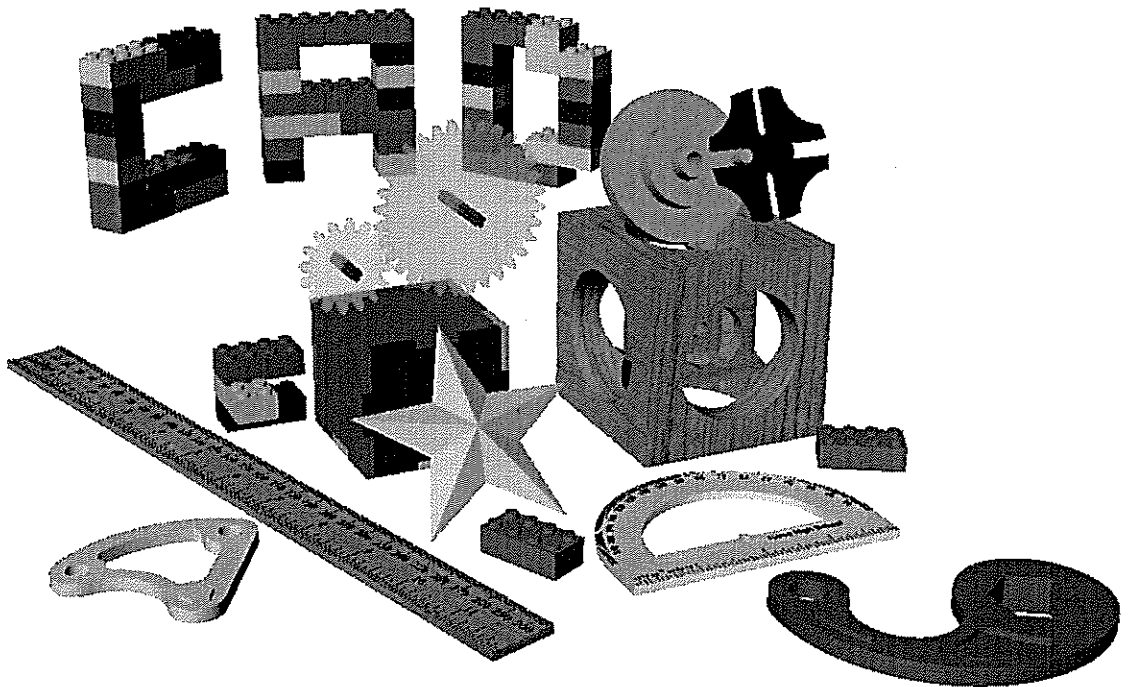

by
Cory Patrick Torppa
June 2010

TABLE OF CONTENTS

| Chapter | | Page |
|---------|---|------|
| | Purpose..... | 50 |
| | Introduction..... | 51 |
| I | LASER ENGRAVER PROJECTS..... | 53 |
| | Purpose of Laser Engraver Projects..... | 53 |
| | Box..... | 54 |
| | Protractor..... | 60 |
| | Ruler..... | 67 |
| | Pi Tape..... | 73 |
| | Golf Ball Box..... | 80 |
| | Star..... | 88 |
| | Y-Tube..... | 96 |
| | Inlay Initials..... | 102 |
| | Lego..... | 107 |
| | Gears..... | 112 |
| | Cabin..... | 117 |
| II | MILLING MACHINE PROJECTS..... | 135 |
| | Purpose of Milling Machine Projects..... | 135 |
| | G&M Code Square..... | 139 |
| | G&M Code House..... | 141 |
| | G&M Code Square-Circle-Triangle..... | 143 |
| | G&M Code Name..... | 146 |
| | Square-Circle-Triangle Male/Female..... | 149 |
| | Keychain..... | 156 |
| | Calculator..... | 162 |
| | Gasket..... | 169 |
| | Cam..... | 174 |
| | Frisbee..... | 179 |
| | Lego..... | 184 |
| | Adaptive Device..... | 190 |
| | Small Box..... | 196 |
| | Cube..... | 201 |
| | Captive Cube..... | 206 |
| | Geneva Gear..... | 212 |
| | APPENDIXES..... | 219 |
| | Appendix A—Curriculum and Standard Alignment..... | 219 |
| | Appendix B—Mathematics Formulas..... | 227 |

Purpose

This workbook is designed as a resource guide for CAD/CAM/CNC teachers to use in their classrooms at the high school level. In effort to support the CAD/CAM/CNC programs in Washington, the workbook has the state standards incorporated within each project provided. Since students in Washington State, starting with the class of 2013, must earn 3 credits of mathematics, the workbook is strongly influenced with math related problems in effort to support CAD/CAM/CNC curriculum. There is a lot of pressure on Career and Technology Education programs right now because more and more students are being pulled out of classes for more math classes and remediation. If teachers do not make an effort to align with a course equivalency in math they will suffer with the loss of students in their program and possibly have to shut their programs down in the future. The curriculum in the workbook may be enough support for a CAD/CAM/CNC program to be approved for a mathematics course equivalency credit, however it is up to the local school district to approve such an equivalency ("Equivalency Credit," 2009, p. 13). This workbook is a key that could keep the door unlocked in the future.

Despite the mathematics course equivalency having a strong influence on the creation of the workbook, the overall purpose of the workbook is to implement hands-on activities with the use of CAD/CAM/CNC in efforts too enhance student interest and understanding in science, technology, engineering, and mathematics (STEM). The workbook is designed to expose students to technology and skills that are transferable to the manufacturing industry and many related trades.

Introduction

As a result of there being very few resources or books available that provide hands-on lessons and projects related to CAD/CAM/CNC, the author has created a workbook that can serve as such a resource. The workbook is designed to provide teachers with hands-on activities and projects that can engage students in learning and apply concepts in the CAD/CAM/CNC content area. To help do so the author has provided 27 CAD projects that involve using a CNC laser engraver and a CNC milling machine.

Within the workbook one will find 11 projects that have been designed to use a laser engraver and 16 that are designed to be used with a milling machine. Each project has a student handout that contains the learning targets and design parameters that are needed for students to get started. Upon completion of each project the students have a list of assignments they must complete, which include STEM related activities. The activities include drawing, measuring, cutting, writing, creating tutorials, calculating displacement, designing and building jigs and fixtures, and much more.

Being that there are a lot of teachers new to CAD/CAM/CNC, each project has a tutorial provided to help walk teachers through how to complete them. Every assignment in the workbook also comes with all the 2D drawings and 3D models needed for the projects. The tutorials tell the teacher when and how they need to use each file.

At the end of the workbook there is a table that breaks down how the state standards are incorporated within each project. Each project is aligned with the General Drafting 15.1301 frameworks and the College-Readiness Standards for Mathematics.

Again the curriculum in the workbook may be enough for a local school district to approve a CAD/CAM/CNC program for a mathematics course equivalency credit.

Finally, it is recommended that each teacher completes the projects in the workbook to see how they fit within their program. Many of the projects can be used with other CNC machines such as plasma cutters, vinyl cutters, or 3D printers. They can also be used within a program that does not have any CNC machines, which can be done by using a printer, glue, and hand or power tools such as a scroll saw. The workbook is to be distributed via compact disc to allow teachers to adapt the curriculum to meet their needs. After all, one of the primary goals of the workbook is to provide teachers with curriculum they can use.

CHAPTER I

LASER ENGRAVER PROJECTS

Purpose of Laser Engraver Projects

The laser engraver assignments were designed to teach students how to create a project given a set of parameters. A laser engraver is a very easy CNC machine for a student to learn how to use and have success with early on in a CAD/CAM/CNC program. Much of this is due to the fact that a laser engraver is set up much like a printer when it comes to cutting or engraving a project. Also, a lot of what is covered in beginning CAD courses tends to be more 2 dimensional and that is exactly what a laser engraver cuts. Using such a machine teaches students about measurement, layers, scaling of projects, 2D layouts, parameters, and much more. With a little creativity a CAD/CAM teacher could do endless amounts of projects with a laser engraver. The CNC machine is very universal as it can cut out parts, engrave curves, text, etch or burn pictures, and engrave endless amounts of fine detail work. It is important to note that most of the laser engraver projects in the workbook are inexpensive. In essence, the goal is to get a project in the student's hands to make the learning more relevant and motivating. Laser engraver projects that involve cutting or etching plastics and wood are a cheap and an easy way to do so.

Building a Box Using the Laser Engraver

Student Learning Targets

I can create a box given a set of parameters

- I will do this by using Rhino (CAD)
- I will work in both 2D and 3D space
- I will demonstrate this by creating a box that meets the given parameters

Design Parameters

- Must fit on an 8 inch by 8 inch piece of .125 inch sheet good
- Must include tab system to join box sides together
- Include your name and the school year as lettering on the box

Perspective

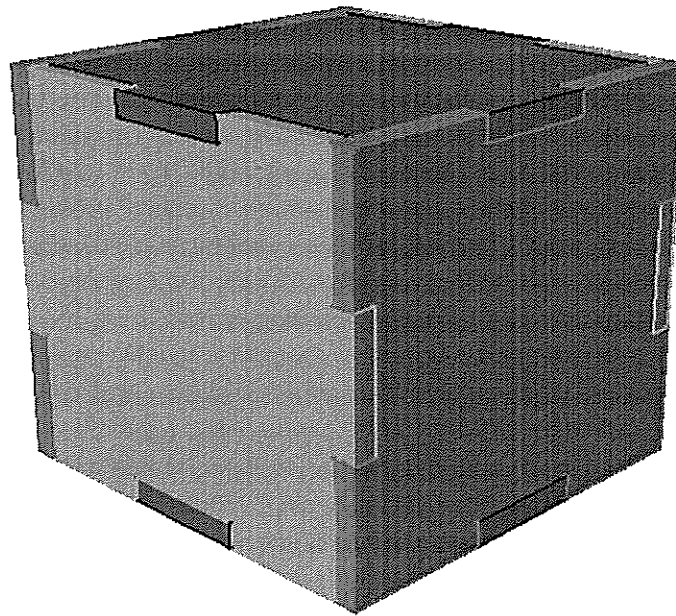

Learning Outcome

In this project the student will learn to create a box using editing and transforming commands. The student will have to apply such commands while they create a 2D layout and 3D model of the box. Finally, the student will learn the importance of layers and scaling an object to cut the box out to its actual size. The commands and techniques used in this project are regularly used in CAD.

The Following Must be Turned in with the Box Project

Turn in project in the following order

- Project cover page
- Completed math problems below
- Page layout of box (see figure 1a)
 - 1 detail of top view (show 2D layout as if to be laser engraved, show dimensions of inside box pieces)
 - 1 detail of a rendered perspective (displays the box fits together)
- Laser engraved box

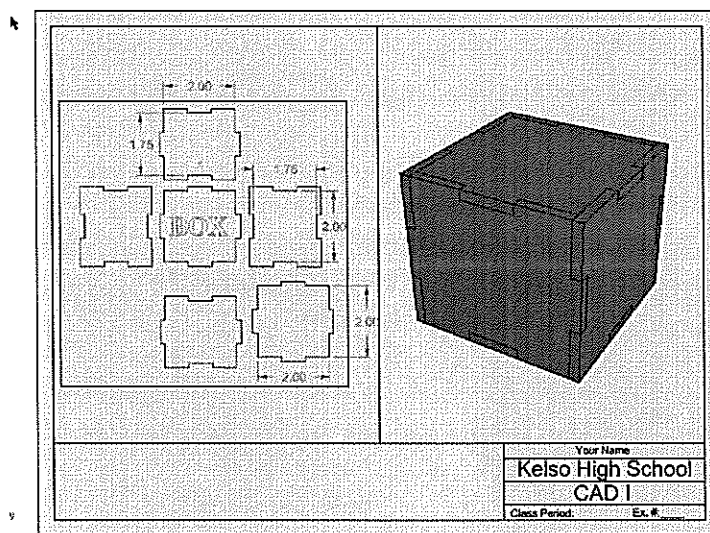

Figure 1a

Complete the Following Math Questions for the Box Project YOU MUST SHOW ALL MATH TO RECEIVE CREDIT!!!

1. How much water would your box hold in cubic inches? (round to nearest .00001)

2. How much water would your box hold in gallons? (round to nearest .00001)

3. How much would the water inside the box weigh in pounds? (round to nearest .00001)

4. What is the total surface area of the outside of the box? (round to nearest .01)

5. How many regular M&M's could fit in your box? (M&M= .636 cubic centimeters)

Directions for the Box Assignment

1. Draw 1 box side, figure 1a

L.

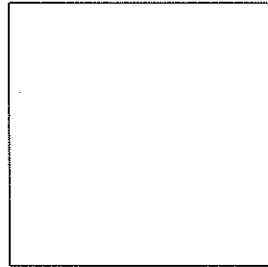

Figure 1a

2. COPY or draw each box side as if the box was laid open, figure 1b

L.

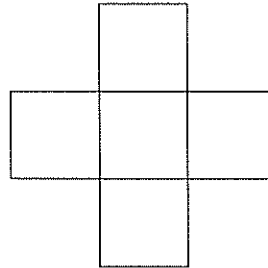

Figure 1b

3. EXPLODE each box side so they are constructed of separate line segments.
4. Use the DIVIDE command to divide each segment to create the tabs and slots (must be divided into an odd number of segments), figure 1c

L.

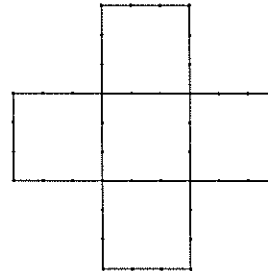

Figure 1c

5. Draw the tabs for the box and use the TRIM command to clean up the tabs and slots (keep in mind the size of the tabs and slots is determined based on the thickness of the material you use)figure 1d

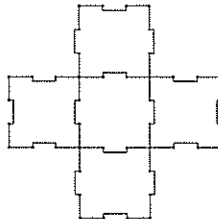

Figure 1d

6. OFFSET 2 of the box sides' segments outwards the thickness of the material to allow for assembly, figure 1e

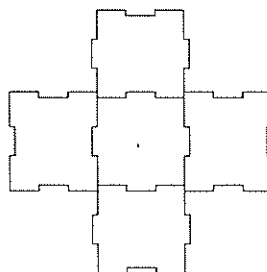

Figure 1e

6. HIDE the points on the box
7. JOIN each sides' segments together
8. Using the RECTANGLE command, draw an 8" x 8" square and center all 6 box pieces within the square to assure that the box will fit on provided material, figure 1f

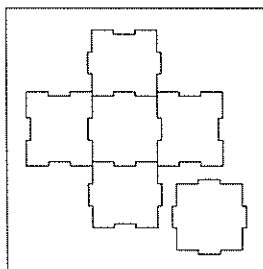

Figure 1f

9. Apply text to the box, make sure your text is curves and is grouped

10. Assign the appropriate layer colors to your box, text, and bounding square to assure the box cuts out correctly with the laser engraver (Tip: you can use the bounding 8" x 8" square to scale your box when you go to cut), figure 1g

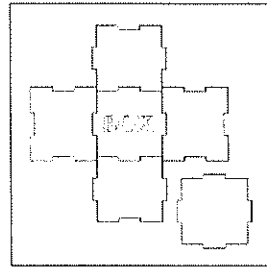

Figure 1g

Prior to cutting the box, extrude and assemble a 3D box using Rhino to assure the box will assemble correctly

11. COPY only the box pieces off to the side, hide all other curves and text

12. Using SOLID-EXTRUDE PLANER CURVES, EXTRUDE your box curves to the thickness of the material you are using, figure 1h

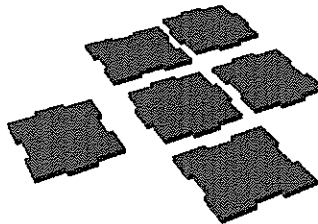

Figure 1h

13. Using the transform commands (MOVE, COPY, ROTATE, MIRROR, etc.) to assemble the box you created, figure 1i

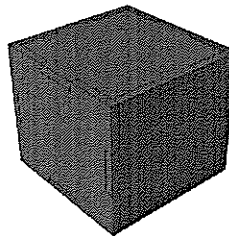

Figure 1i

14. If the box assembles correctly it is time to engrave or print out

Building a Protractor Using the Laser Engraver

Student Learning Targets

I can create a protractor given a set of parameters

- I will do this by using Rhino (CAD)
- I will demonstrate this by creating a protractor that meets the given parameters
- I will show I can accurately use a protractor by laying out and measuring angles
- This means I can accurately use inches, diameter, circumference, perimeter, and degrees as it applies to this project

Design Parameters

- Must fit on a 4 inch by 3 inch piece of .125 inch transparent Acrylic
- Must include a 4 inch ruler with .0625 divisions
- All lettering must be on the side of the protractor that touches the material being measured
- Must measure in 1 degree increments
- Must include an alignment feature as well as a “center target”
- Include your name and the school year as lettering on the protractor
- Label the ruler down to 1/8” increments.

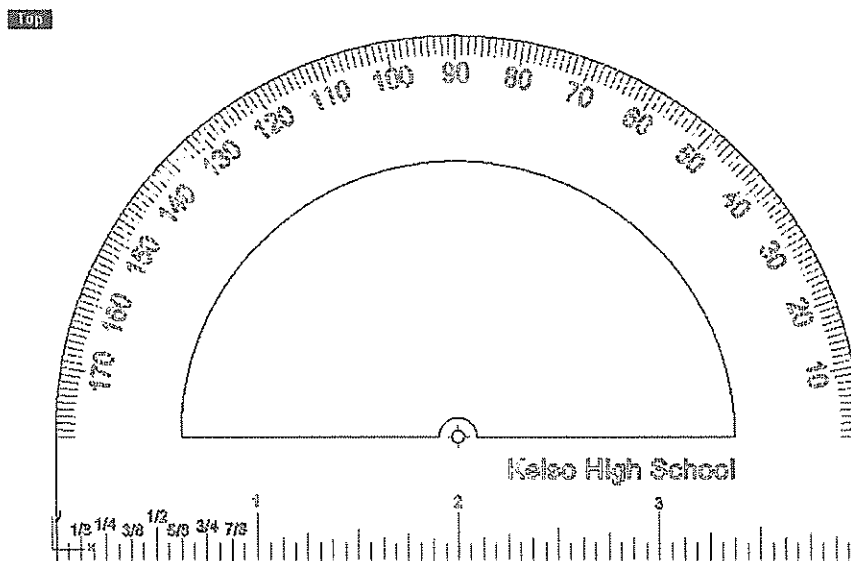

Learning Outcome

In this project the student will learn to apply the curve, text, edit, and transform commands to create a protractor. The student will learn the importance of layers and scaling an object to cut the protractor out to its actual size. The commands and techniques used in this process are regularly used in CAD

The Following Must be Turned in with the Protractor Project

Turn in project in the following order

- Project cover page
- Completed math problems below
- Page layout of protractor (see figure 1a)
 - Center and scale 1 detail of front view in the middle of the page layout (show 2D layout as if to be laser engraved, use 1:1 scale)
- Laser engraved protractor

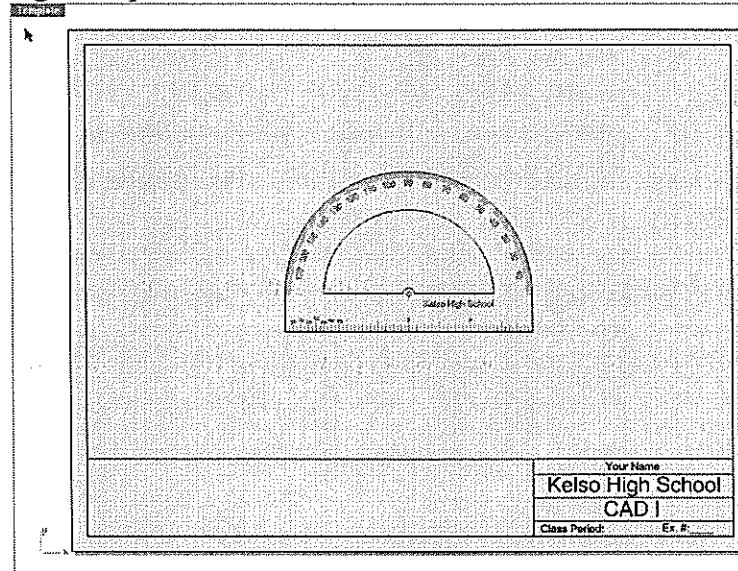

Figure 1a

Complete the Following Math Questions for the Protractor Project
YOU MUST SHOW ALL MATH TO RECEIVE CREDIT!!!

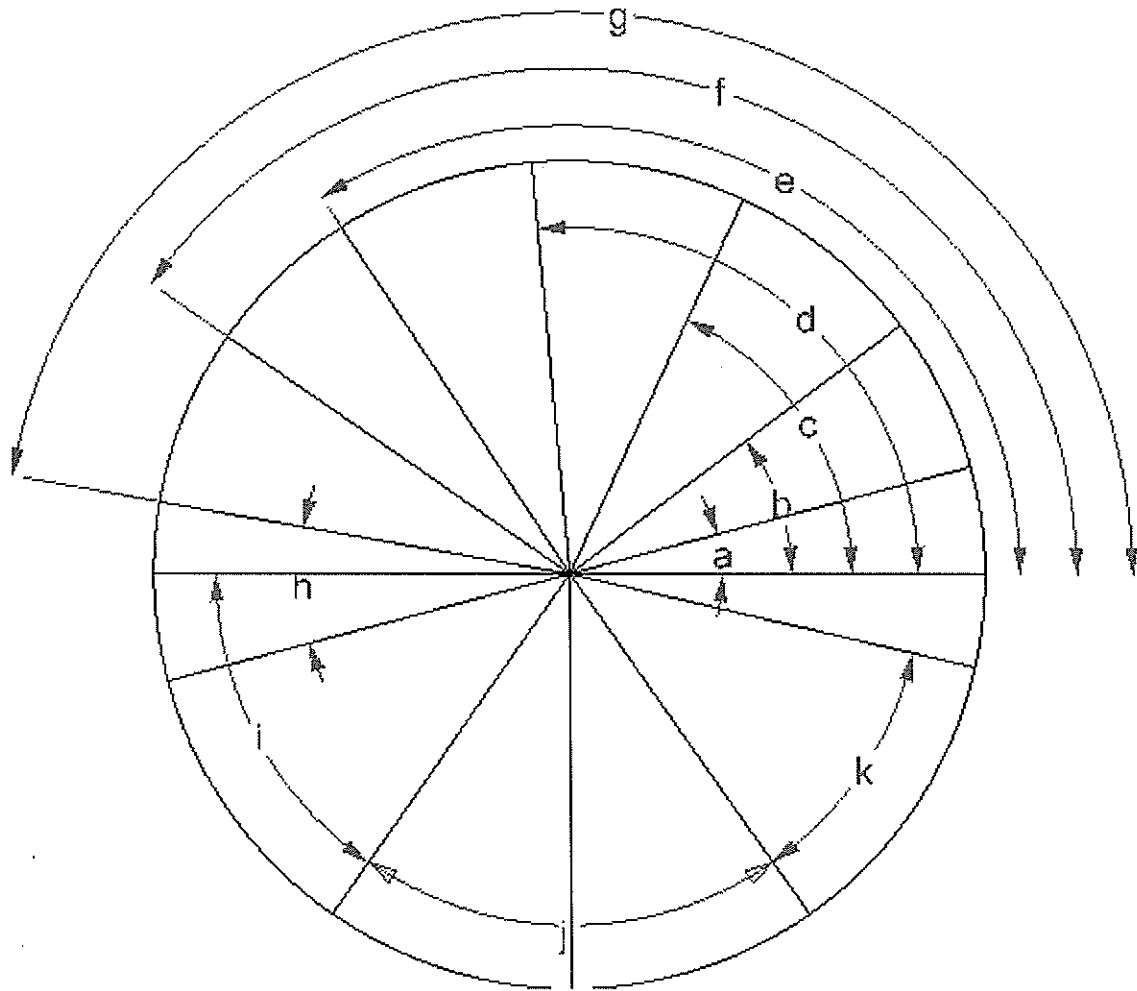

Figure 1b

Find the following angles using figure 1b (use your protractor)

Angle A _____
 Angle B _____
 Angle C _____

Angle D _____
 Angle E _____
 Angle F _____

Angle G _____
 Angle H _____
 Angle I _____

Angle J _____
 Angle K _____

In figure 1c lines AB and CD are parallel and are cut by a third line EF (transversal)
If the measure of angle 1 is 144 degrees, find the measure of each angle.

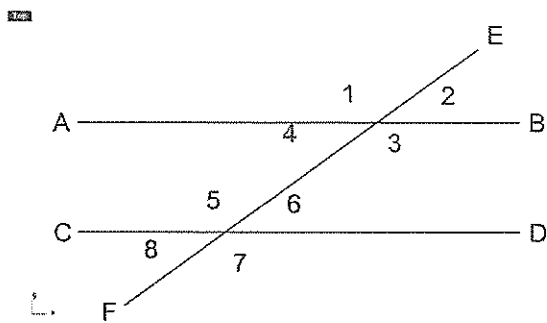

Angle 2 _____
Angle 3 _____
Angle 5 _____
Angle 7 _____
Angle 8 _____

Figure 1c

Directions for the Protractor Assignment

1. Draw a 4" diameter circle.
2. Draw a horizontal line segment from quadrant to quadrant, figure 1a

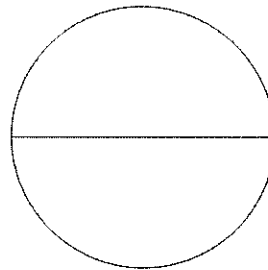

Figure 1a

3. TRIM the circle, figure 1b

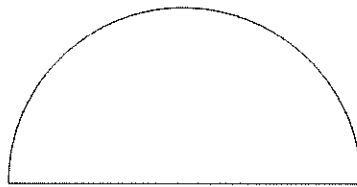

Figure 1b

4. Delete the horizontal line
5. Starting on the bottom left of the arc, draw a line segment down .625", continue across the diameter, and end the segment at the bottom right of the arc, figure 1c

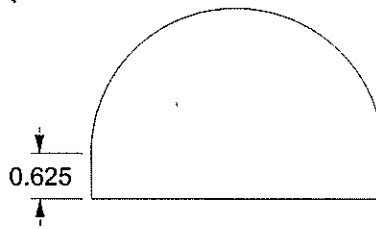

Figure 1c

6. JOIN the arc and line segments together
7. OFFSET the curve inward .625, figure 1d

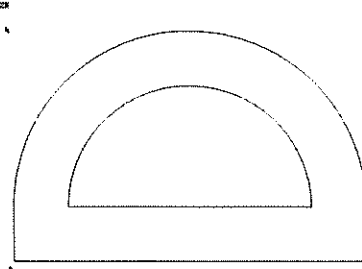

Figure 1d

8. Create an alignment feature (center target) as desired, figure 1e

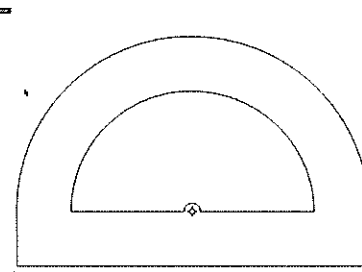

Figure 1e

9. EXPLODE the outer curve
 10. Analyze the length of the top arc= 6.283"
 11. Draw a line 6.283" long
 12. On the left side of the 6.283" long line, draw a line down .1", figure 1f



Figure 1f

13. ARRAY the .1" line along the 6.283" curve 181 times, figure 1g

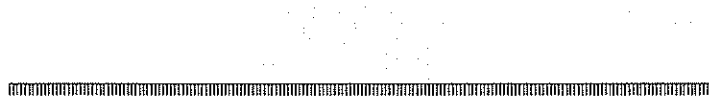

Figure 1g

14. EXTEND every 10th line by .025 to better represent every 10 degrees, figure 1h

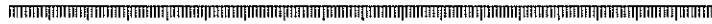

Figure 1h

15. Label every 10 degrees, figure 1i



Figure 1i

16. Use the Transfer- FLOW ALONG CURVE command to flow the degree lines and text around the protractor, figure 1j

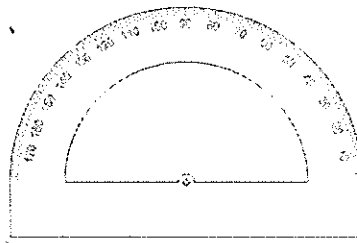

Figure 1j

17. Create a 4" ruler across the bottom of protractor, figure 1k

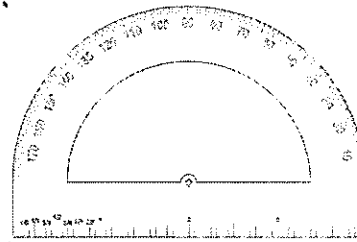

Figure 1k

18. Add any last text you want

19. Prior to engraving with laser engraver, MIRROR the protractor to engrave on the back side of the plastic, figure 1l

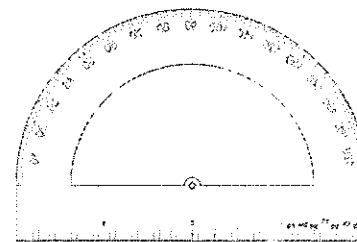

Figure 1l

Building a 12" Ruler Using the Laser Engraver

Student Learning Targets

I can create a ruler given a set of parameters

- I will do this by using Rhino (CAD)
- I will demonstrate this by creating a ruler that meets the given parameters
- I will show I can accurately use a metric and standard ruler by measuring lines
- This means I can accurately read a standard ruler to 1/16" precision
- This means I can accurately read a metric ruler using millimeters and centimeters

Design Parameters

- Must be centered on 1" x 12" piece of 1/8" inch transparent Acrylic
- Must include divisions to 1/16" precision on standard edge
- Label the ruler down to 1/4" increments on standard edge
- Must include both millimeters and centimeters on metric edge
- Label every ten millimeters on metric edge
- Place full name and school name on ruler
- Text height is .125
- Length of line segments are as follows:

| Precision | Length of line | Precision | Length of line |
|-----------|----------------|-----------|----------------|
| 1/16" | 0.125 | mm | 0.125 |
| 1/8" | 0.1875 | cm | 0.25 |
| 1/4" | 0.25 | | |
| 1/2" | 0.3125 | | |
| 1" | 0.375 | | |

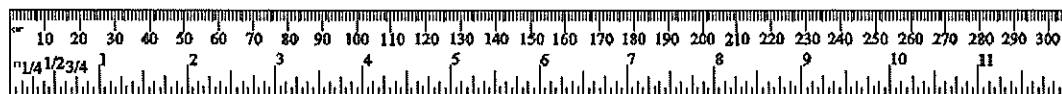

Learning Outcome

In this project the students will learn to apply the curve, text, edit, and transform commands to create a ruler. The student will learn to read a metric and standard ruler. The ruler will be used to do measuring activities throughout the semester.

The Following Must be Turned in with the Ruler Project

Turn in project in the following order

- Project cover page
- Completed math problems below
- Page layout of ruler (see figure 1a)
 - 1 detail of top or front view (show 2D layout as if to be laser engraved)
- Laser engraved ruler

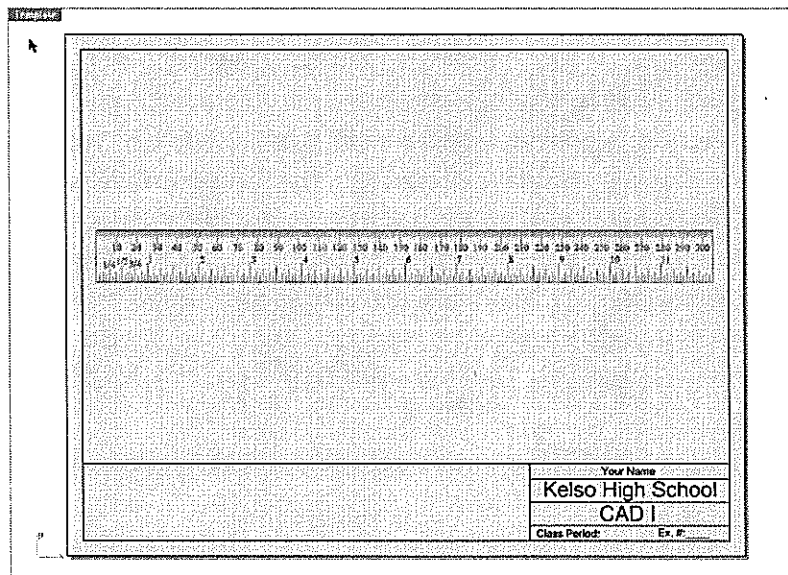
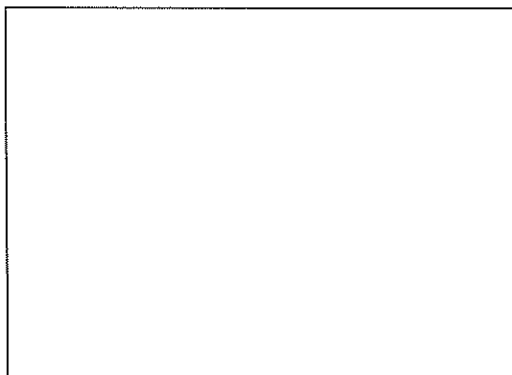

Figure 1a

Complete the Following Math Questions for the Ruler Project YOU MUST SHOW ALL MATH TO RECEIVE CREDIT!!!



1. Find the perimeter of the rectangle in inches. (nearest 1000th)

2. Find the area of the rectangle in millimeters. (nearest mm)

3. If the rectangle was extruded to a thickness of $\frac{1}{2}$ " what would the volume of the block be in cubic inches? (nearest 100th)

1.

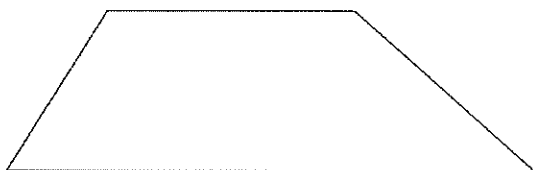

2.

1. Find the perimeter of the trapezoid in millimeters. (nearest mm)

2. Find the area of the trapezoid in inches. (nearest 1000th)

1.

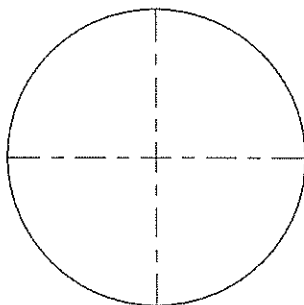

2.

1. Find the circumference of the circle in centimeters. (nearest 100th)

2. If the circle was extruded to a height of 3 cm, what would the volume of the cylinder be in cubic centimeters? (nearest 1000th)

Directions for the 12" Ruler Assignment

1. Draw a 1" x 12" rectangle using the RECTANGLE command, figure 1a

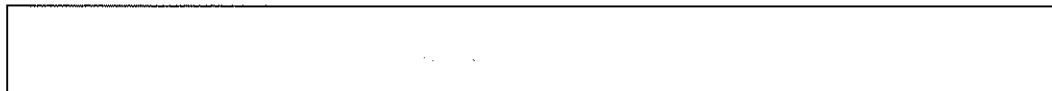

Figure 1a

2. EXPLODE the rectangle into separate line segments
3. OFFSET the bottom line of the rectangle upwards .125", .1875", .25", .3125", and .375", figure 1b



Figure 1b

4. Draw a line from the bottom left hand corner of the rectangle upwards .125"
5. ARRAY the line along the bottom curve of the rectangle with a distance of .0625, figure 1c



Figure 1c

6. EXTEND every 1/8" line up to the .1875" line, figure 1d



Figure 1d

7. EXTEND every 1/4" line up to the .25" line, figure 1e



Figure 1e

8. EXTEND every $\frac{1}{2}$ " line up to the .3125" line, figure 1f



Figure 1f

9. EXTEND every 1" line up to the .375" line, figure 1g



Figure 1g

10. HIDE the offset lines, figure 1h

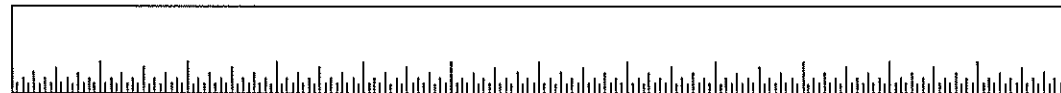

Figure 1h

11. OFFSET the top line of the rectangle down .125 and .25, figure 1i

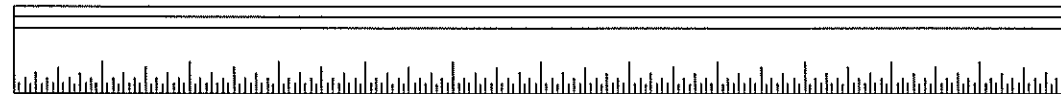

Figure 1i

12. Starting at the top left-hand corner of the rectangle, draw a line down .125
13. ARRAY the line along the top curve of the rectangle with a distance of .03937, figure 1j

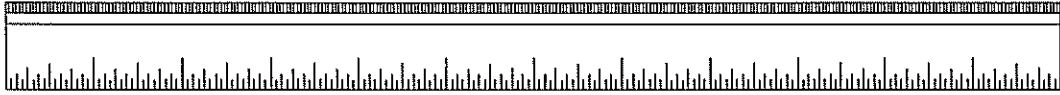

Figure 1j

14. EXTEND every centimeter line to the .25" line, figure 1k

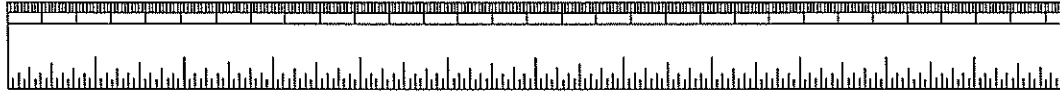

Figure 1k

15. HIDE the offset lines, figure 1l

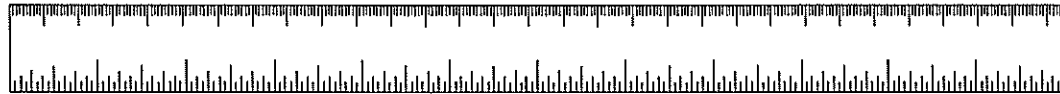

Figure 1l

16. Label the ruler using text (curves), figure 1m

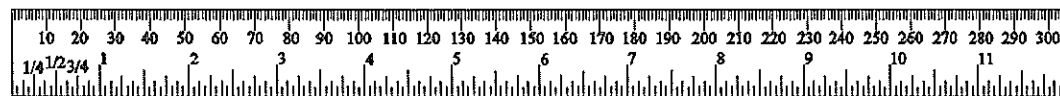

Figure 1m

17. Assign the appropriate layer colors to your ruler, figure 1n

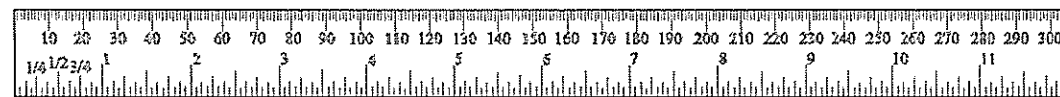

Figure 1n

18. Cut ruler out with laser engraver

Building a Pi Tape Using CAD

Student Learning Targets

I can create a pi tape given a set of parameters

- I will do this by using Rhino (CAD)
- I will demonstrate this by creating a pi tape that meets the given parameters
- I will show I can accurately use a pi tape by measuring multiple cylinders
- This means I can accurately read a standard ruler to 1/16" precision
- This means I can accurately read a dial caliper
- This means I can accurately read a micrometer
- This means I can accurately use inches, diameter, circumference, and pi as it applies to this project

Design Parameters

- Use a template or set units to inches
- Construct a standard 6 inch ruler with divisions to 1/16 inch precision
- Label the ruler down to the 1/4 inch increments
- Make sure to put your full name and school name on the ruler
- Total height of the ruler should be *no more* than .318 inches, *including text*
- Copy the ruler and scale one copy by the value of Pi. (*If using a letter size printer you will need to split your Pi scaled ruler into several parts to fit the paper*)
- Make sure you have an accurate "reading line" as well as a means of holding the tape when measuring
- Using the materials provided, test your Pi tape. Use your standard ruler to measure the diameter and the Pi tape to measure the circumference. If your work is accurate the rule and the tape will agree. Check the accuracy of your ruler with a "factory" ruler

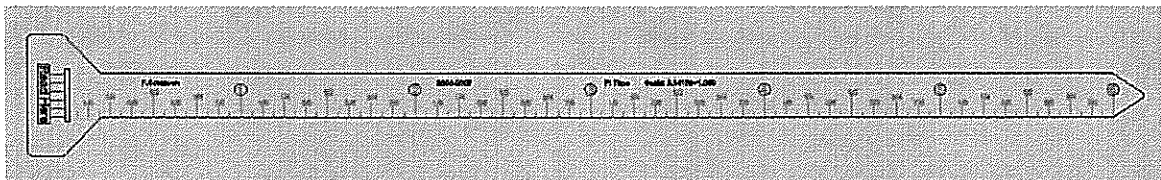

Learning Outcome

In this project the student will learn to apply the curve, text, edit, and transform commands to create a pi tape. The student will learn how to use a pi tape to find the diameter of a round object. The pi tape will be used to do measuring activities throughout the semester.

The Following Must be Turned in with the Pi Tape Project

Turn in project in the following order

- Project cover page
- Completed math problems below
- Printed Pi Tape (print to 1:1 scale), see figure 1a

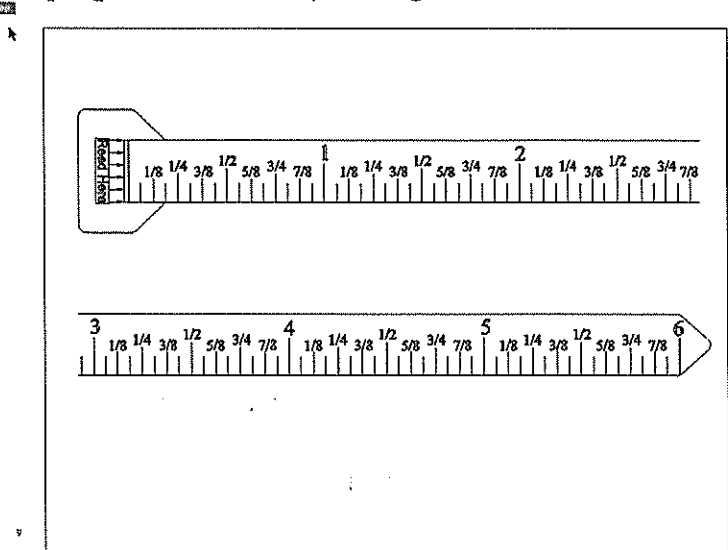

Figure 1a

Complete the Following Math Questions for the Pi Tape Assignment YOU MUST SHOW ALL MATH TO RECEIVE CREDIT!!!

Worksheet instructions:

- Teacher will assign the student 6 plumbing pipes to work with
- Complete the following chart in numerical order.
- Provide ALL math calculations below

| Pipe # | O.D. | I.D. | Wall Th. | Volume |
|--------|------|------|----------|--------|
| | | | | |
| | | | | |
| | | | | |
| | | | | |
| | | | | |

Pipe #: located on pipe

O.D.: outside diameter

I.D.: inside diameter (subtract wall thickness from O.D.)

Wall Th.: wall thickness

Directions for Making the Pi Tape

- Using the RECTANGLE command, draw a rectangle .318" x 6", figure 1a



Figure 1a

- Starting at the bottom left corner of the rectangle, draw a LINE to the right 1"
- OFFSET the 1" line you just drew upward .1", .125", .15", .175", and .2", figure 1b

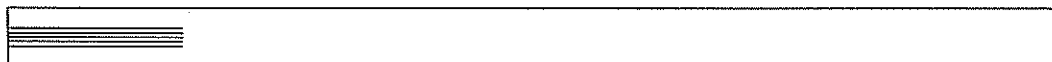

Figure 1b

- Starting at the bottom left hand corner of the rectangle, draw a LINE up .1"
- ARRAY the .1" line you just drew along one of the 1" lines with a distance between items set at .0625", figure 1c

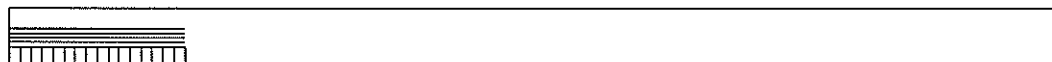

Figure 1c

- EXTEND every 1/8" line up to the .125" line, figure 1d



Figure 1d

- EXTEND every 1/4" line up to the .15" line, figure 1e

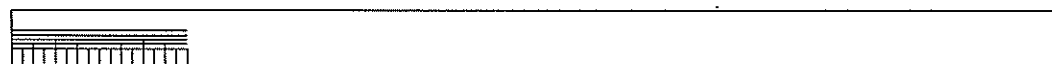

Figure 1e

- EXTEND the 1/2" line up to the .175" line, and the 1" line up to the .2" line, figure 1f



Figure 1f

- HIDE the lines you offset and the .1" and 1" lines you draw from the bottom of the rectangle
- Using the SOLID-TEXT-CURVES, label the ruler down to 1/8" increments (text height of .05", or scale as desired), figure 1g

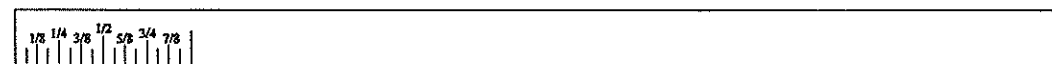

Figure 1g

11. COPY the ruler to the right, using the bottom left hand corner of the rectangle as the point to copy from, figure 1h

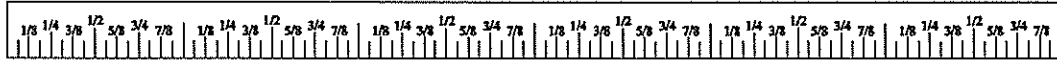

Figure 1h

12. Label every inch, figure 1i

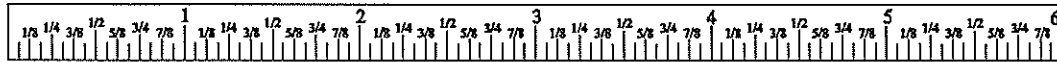

Figure 1i

13. COPY the ruler off to the side
14. HIDE one of the rulers
15. SCALE one ruler by the value of Pi
16. Use LINE SEGMENTS, FILLETS, OFFSETS, TEXT, LEADERS, to create a “reading line, figure 1j

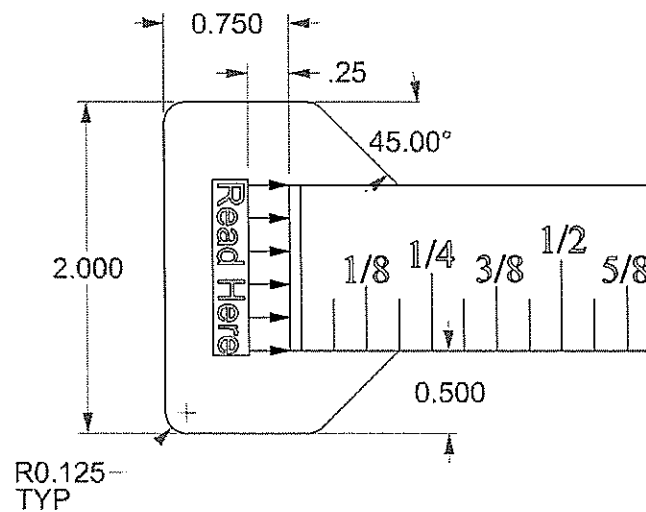

Figure 1j

17. Create the tip of the ruler, figure 1k

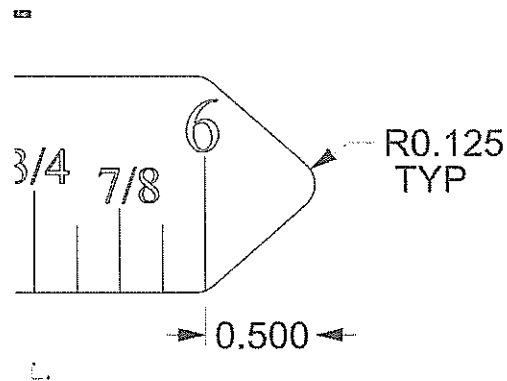

Figure 1k

18. Your Pi Tape is complete but must be SPLIT into sections to fit on the paper you are printing with

19. OFFSET the vertical line segment on the left side of your Pi Tape to use for splitting (in the example the line was offset 10", to fit on 11 x 8.5 paper-landscape) figure 11

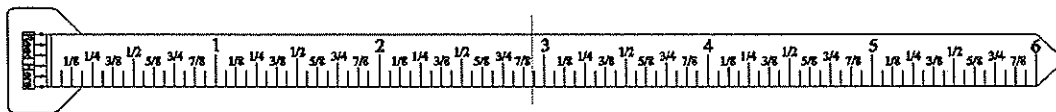

Figure 11

20. SPLIT the Pi Tape into 2 sections

21. Using the RECTANGLE command, draw a 11" x 8 1/2" rectangle

22. MOVE the Pi Tape pieces so they fit in the rectangle, figure 1m

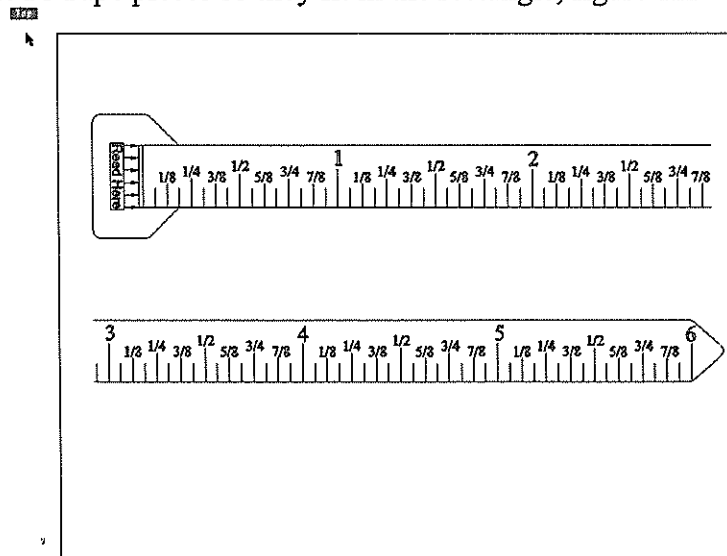

Figure 1m

23. Print the Pi Tape, cut out with scissors, and use packaging tape on both sides to laminate the tape

24. Test your Pi Tape

Building a Golf Ball Box Using the Laser Engraver

Student Learning Targets

I can create a golf ball box given a set of parameters

- I will do this by using Rhino (CAD)
- I will work in both 2D and 3D space
- I will do this by creating a flat layout from a 3D object
- I will demonstrate this by creating a golf ball box that meets the given parameters
- This means I can accurately use radius, diameter, area, and volume as it applies to this project

Design Parameters

- Box must hold 2 golf balls
- Edges of golf balls must protrude out from each edge of box
- Cannot use glue, tape, etc. to fasten together
- Must use tabs and slots
- Print name and school year on box
- Use inches
- Must be able to fit and ship a dozen golf balls to a sporting goods store using the provided shipping box in the class
- For an "A" the shipment of golf ball boxes must fit snug in the shipping box

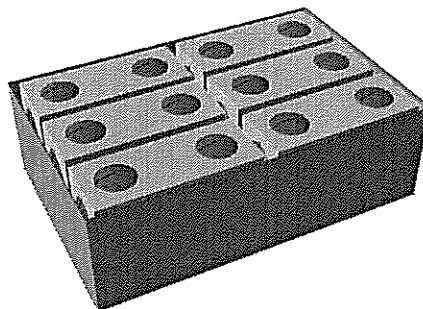
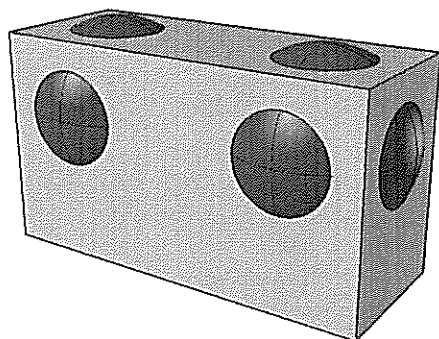

Learning Outcome

In this project the student will use surface or solid modeling techniques to create a golf ball box. The student will learn how to unroll a surface from an object to create a 2D layout, similar to what is done in the sheet metal industry. The challenge and parameters of the golf ball box will teach students to plan ahead and focus on the importance of design.

The Following Must be Turned in with the Golf Ball Box Project

Turn in project in the following order

- Project cover page
- Completed math problems below
- Page layout of golf ball box (see figure 1a)
 - 1 detail of top view (show 2D layout as if to be laser engraved, show dimensions of box sides and tabs)
 - 1 detail of a rendered perspective (displays the box fits together)
- Laser engraved golf ball boxes (must cut enough to ship 12 golf balls)

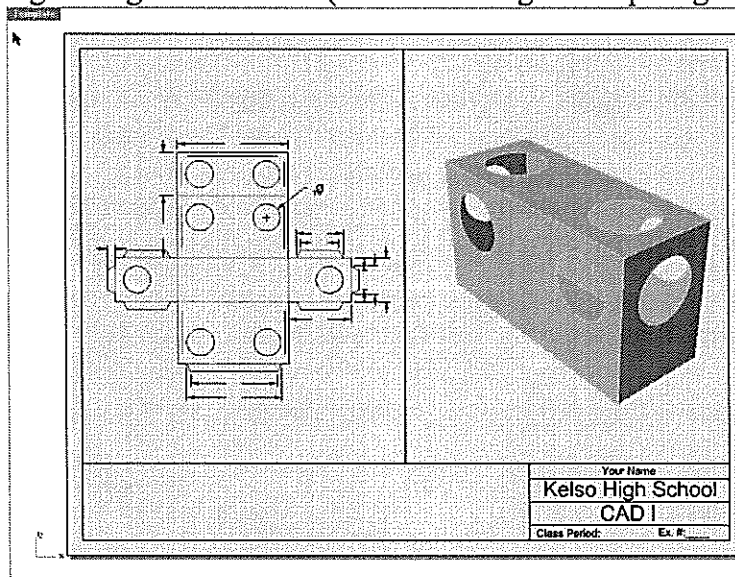

Figure 1a

Complete the following math questions for the golf ball box assignment
SHOW ALL WORK FOR CREDIT

1. If it cost the golf ball company \$.0075 per cubic foot of box space to ship their product how much would the *shipping box* cost to ship? (round to nearest \$.01)

2. Sketch and fully dimension your golf ball box below. (see example- figure 1b)

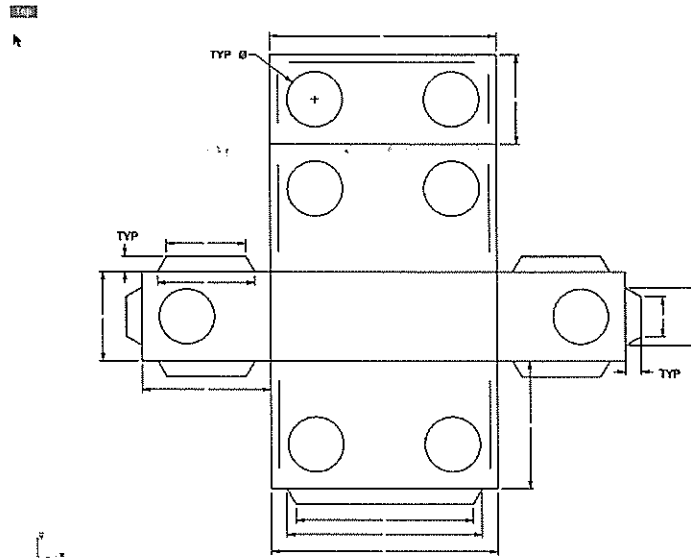

Figure 1b

Directions for Creating a Golf Ball Box

1. Find the diameter of a golf ball
2. Create a top view sketch of how you want 2 golf balls to be positioned in a box (golf ball must protrude out from edges of box) figure 1a

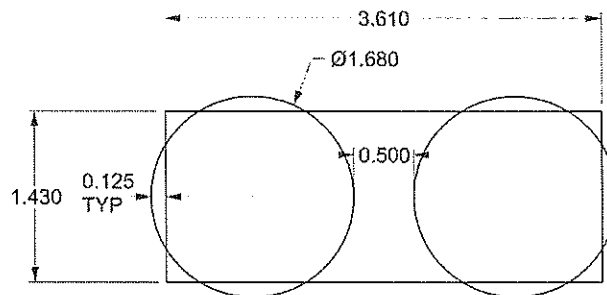

Figure 1a

3. COPY one drawing of the sketch off to the side
4. HIDE one copy
5. EXTRUDE the box using SURFACE-EXTRUDE CURVE-STRAIGHT (the height of the box is determined by where you want the golf balls to sit in the box, in the example the balls will be raised up ½" from the box bottom), figure 1b

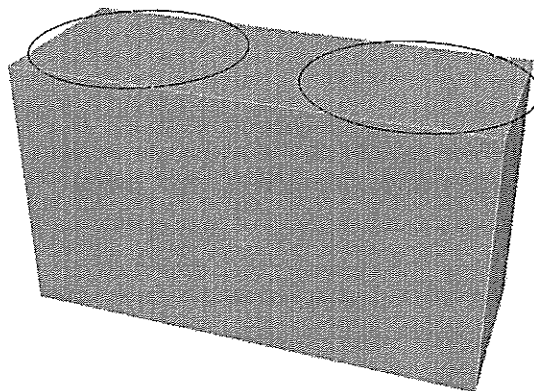

Figure 1b

6. HIDE the box

- Using the Center OSNAP draw a line down from the center of the circles the distance you want the center of the golf balls to be located, figure 1c

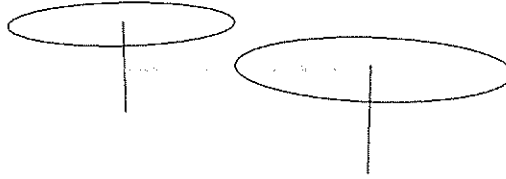

Figure 1c

- Using the SPHERE command, create 2 spheres using the end point of the lines you just drew, figure 1d

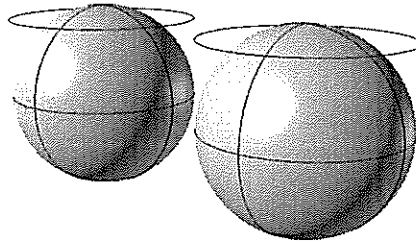

Figure 1d

- HIDE all curves

- SHOW the box, figure 1e

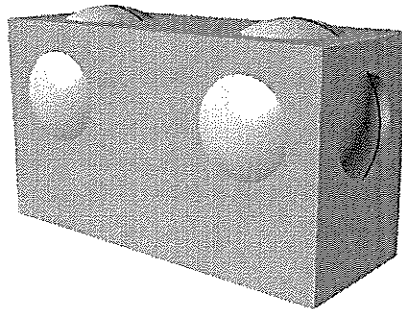

Figure 1e

- Use the SPLIT command to split the box using the spheres as cutting objects
- HIDE the spheres

13. DELETE the split surfaces on the box, figure 1f

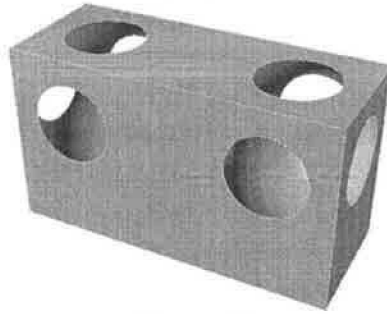

Figure 1f

14. Use the SURFACE-UNROLL DEVELOPABLE SRF command to unroll the box, figure 1g

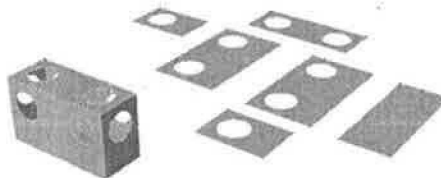

Figure 1g

15. Window select all the unrolled surfaces
16. Use the CURVE-CURVE FROM OBJECT-DUPLICATE EDGE command to duplicate all the edges on the unrolled surfaces
17. HIDE the box and all surfaces, figure 1h

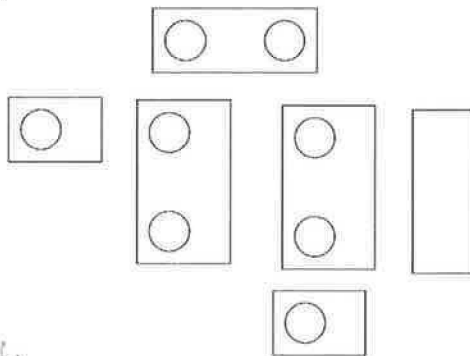

Figure 1h

18. GROUP each side's segments and circles together

19. Use the MOVE, ROTATE, and MIRROR commands to align the golf ball box as though it was laid open, figure 1i

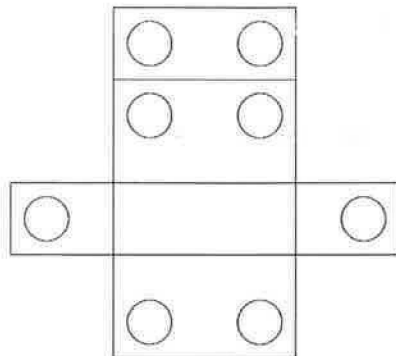

Figure 1i

20. Draw a tab system for the entire box (bring in cereal, cracker, and other packaging boxes to look at for examples), figure 1j

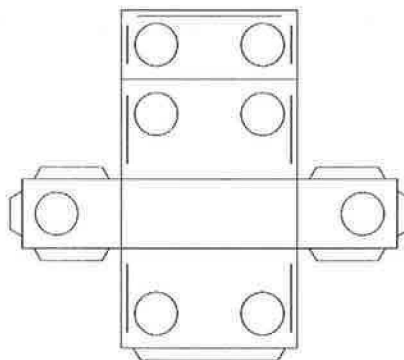

Figure 1j

21. Assign the appropriate layer colors to your box, figure 1k

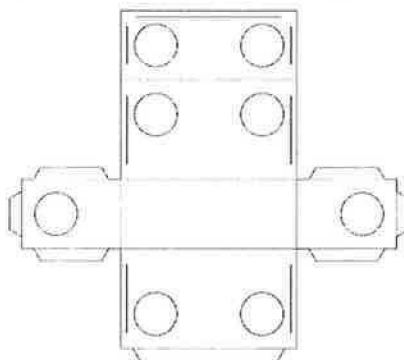

Figure 1k

22. Your golf ball box is now ready to engrave or print out

Building a Star Using the Laser Engraver

Student Learning Targets

I can create a star given a set of parameters

- I will do this by using Rhino (CAD)
- I will work in both 2D and 3D space
- I will do this by creating a flat layout from a 3D object
- I will demonstrate this by creating a star that meets the given parameters
- This means I can accurately use radius, diameter, area, and measure angles as it applies to this project

Design Parameters

- Measure and sketch the star on the wall
- Draw the star $\frac{1}{4}$ of its original scale in 3D using Rhino
- Create a flat layout of the star with 2D curves ($\frac{1}{4}$ scale)
- Must show all folds
- Must use tab system to assemble star
- Include your name and the school year as lettering on the star

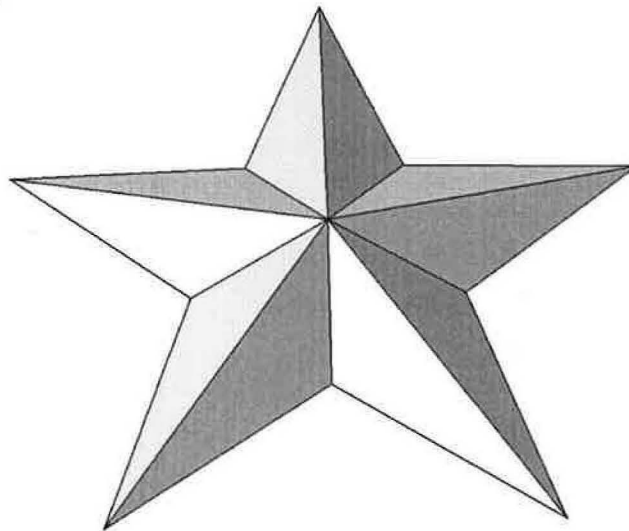

Learning Outcome

In this project the student will model a star using surfaces. The student will learn how to unroll a surface from an object to create a 2D layout, similar to what is done in the sheet metal industry. The challenge of the tab system used to assemble the star will teach students to plan ahead and focus on the importance of design.

The Following Must be Turned in with the Star Project

Turn in project in the following order

- Project cover page
- Completed math problems below
- Page layout of star (see figure 1a)
 - 1 detail of top or front view of star piece to be cut (show 2D layout as if to be laser engraved)
 - 1 detail of a rendered perspective of the completed star
- Laser engraved star

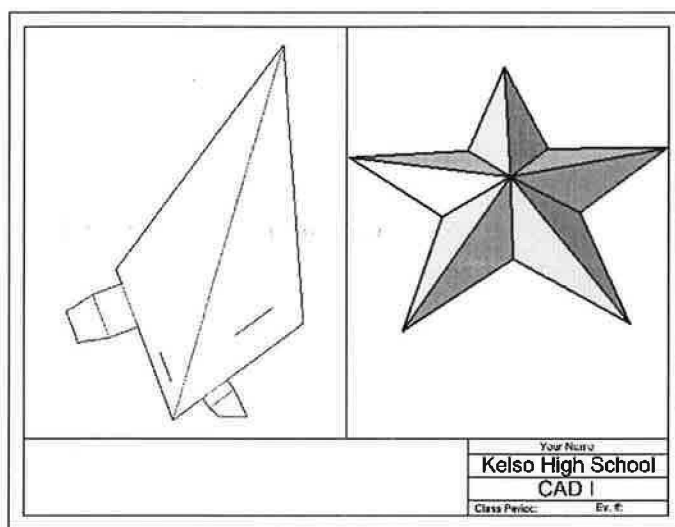

Figure 1a

Complete the Following Math Questions for the Star Project

YOU MUST SHOW ALL MATH TO RECEIVE CREDIT!!!

(Round all answers to nearest 100th)

| | |
|-----------|--|
| <p>1.</p> | <p>1. Find the value of X for the similar triangles.</p> <hr/> <hr/> <hr/> <hr/> <hr/> <hr/> <hr/> <hr/> <hr/> <hr/> |
|-----------|--|

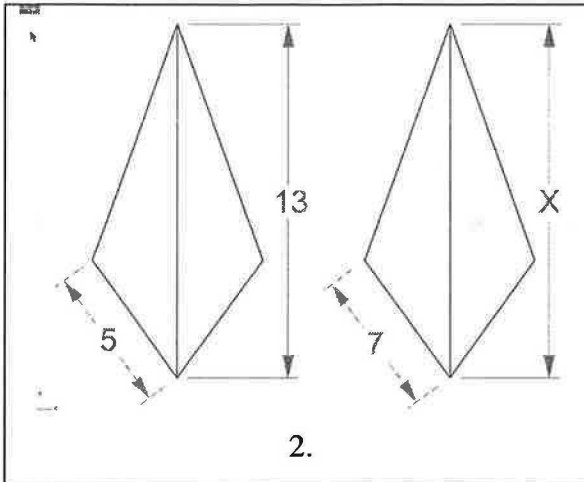

2. Find the value of X for the similar triangles.

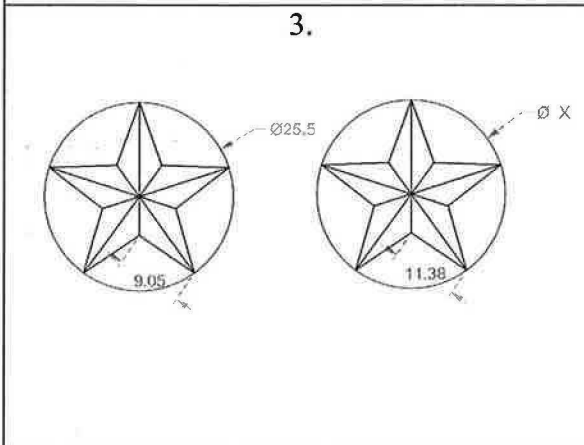

3. Find the value of X.

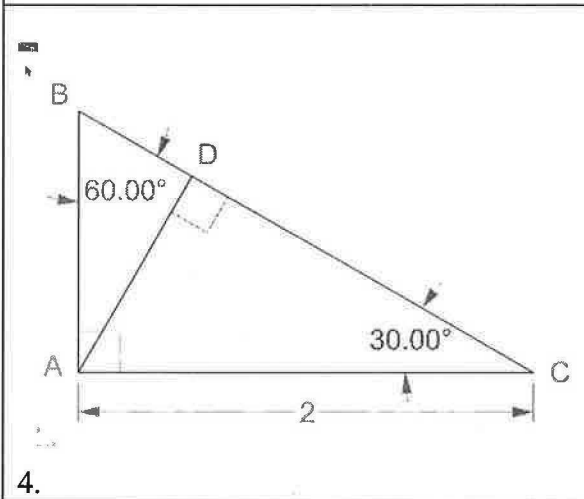

4. Find the following for the 30-60-90 triangle to the left.

CD _____

AD _____

BD _____

AB _____

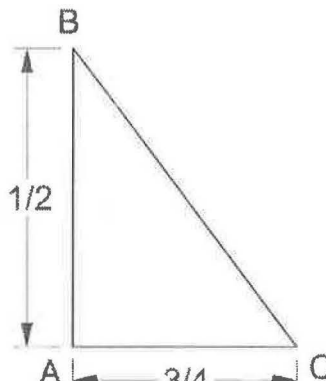
| | |
|---|---|
|  <p>A right-angled triangle with vertices A, B, and C. The right angle is at vertex A. The vertical leg AB has a length of $\frac{1}{2}$, and the horizontal leg AC has a length of $\frac{3}{4}$. The hypotenuse is BC.</p> | <p>5. Use Pythagorean Theorem to find BC.</p> <hr/> <hr/> <hr/> <hr/> <hr/> <hr/> <hr/> <hr/> <hr/> <hr/> |
|---|---|

Directions for the Star Assignment

1. Measure the star that is in the classroom
2. Sketch the star on a piece of paper (note: the 12.75 & 5.25 are linear dimensions, if they were aligned with the angle of the star you would need to use trigonometry to lay the star out) figure 1a

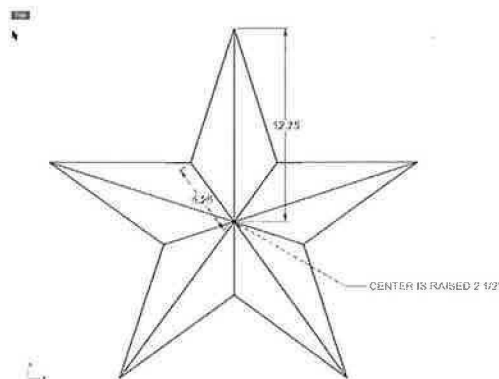

Figure 1a

3. Draw the line segments and center point needed for laying out the star, figure 1b



Figure 1b

4. MOVE the center point up however far your star sticks out (for this example the point is raised up $2\frac{1}{2}$ "")
5. Draw a line segment from the center point, down to the outer endpoint of each of the 2 line segments shown above, figure 1c

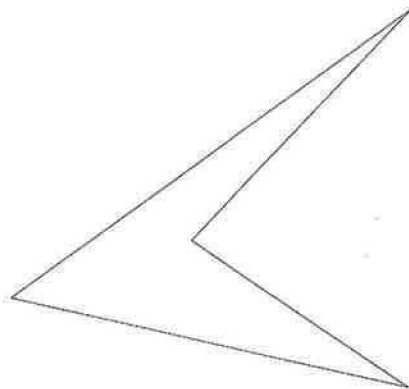

Figure 1c

6. HIDE the original line segments that are in figure 1b
7. MIRROR the smaller line segment about the large line segment, figure 1d

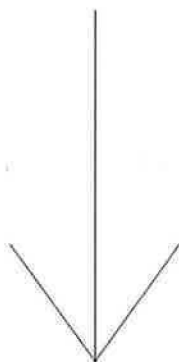

Figure 1d

8. Draw line segments to connect the end points of the smaller line segments to the end of the large line, figure 1e

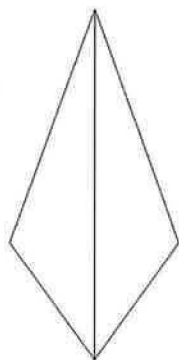

Figure 1e

9. Using SURFACE-EDGE CURVES, create 2 surfaces using the triangles as edges, figure 1f

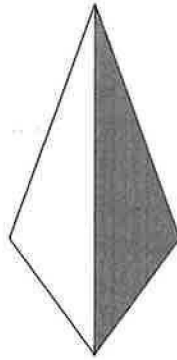

Figure 1f

10. JOIN the 2 surfaces into 1 polysurface

11. HIDE curves and point

12. Use the ARRAY-POLAR command to array the polysurface around the point 5 times, figure 1g

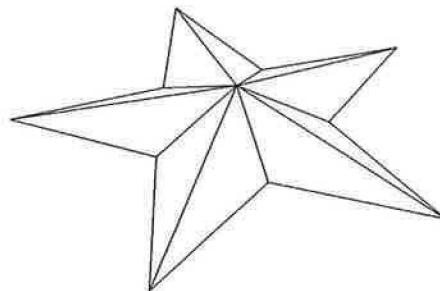

Figure 1g

13. JOIN all the polysurfaces together

14. Use the UNROLL DEVELOPABLE SRF command to unroll the star, figure 1h

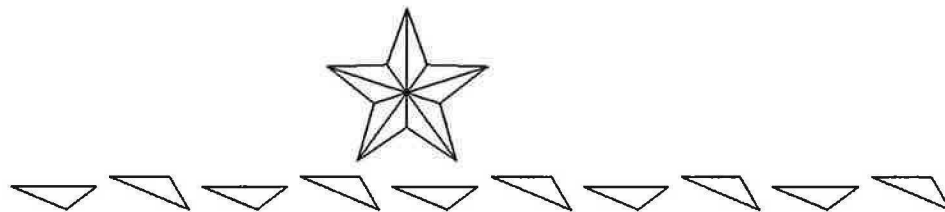

Figure 1h

15. HIDE the star and all but 2 of the unrolled surfaces

16. Use ROTATE and MOVE to connect 2 of the unrolled surfaces, figure 1i

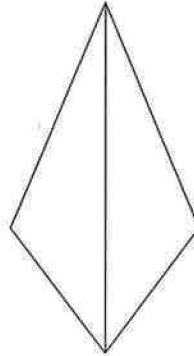

Figure 1i

17. JOIN the 2 surfaces into 1 polysurface

18. Use the CURVE-CURVE FROM OBJECT-DUPLICATE EDGE command to duplicate all the edges on the polysurface

19. HIDE the polysurface

20. Draw a tab system for the star's piece, figure 1j

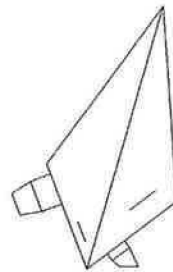

Figure 1j

21. Assign the appropriate layer colors to your star piece, figure 1k

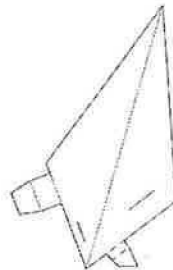

Figure 1k

22. Your star pieces are ready to engrave or print out

Building a Y-Tube Using the Laser Engraver

Student Learning Targets

I can create a y-tube given a set of parameters

- I will do this by using Rhino (CAD)
- I will work in both 2D and 3D space
- I will do this by creating a flat layout from a 3D object
- I will demonstrate this by creating a y-tube that meets the given parameters
- This means I can accurately use radius, diameter, area, and volume as it applies to this project

Design Parameters

- Design must be able to fit on 1 manila folder
- Measure a ball provided by your teacher (use your Pi Tape)
- Draw a tube using the same diameter of the ball
- Make another tube with the same diameter and rotate at 45 degrees
- Create a third tube so the three intersect and create a 'Y'
- Trim tubes to create a 'Y'
- Create a flat-2D layout of the y-tube
- Must show all folds
- Must use tab or slot system to assemble y-tube
- Use lines to help line up paper for assembling
- Include your name and the school year as lettering on the y-tube



Learning Outcome

In this project the student will model a y-tube using surfaces. The student will learn how to unroll a surface from an object to create a 2D layout, similar to what is done in the sheet metal industry. The challenge of the tab system used to assemble the y-tube will teach students to plan ahead and focus on the importance of design.

The Following Must Be Turned In with the Y-Tube Project

Turn in project in the following order

- Project cover page
- Completed math problems below
- Page layout of y-tube (see figure 1a)
 - 1 detail of top or front view of y-tube pieces to be cut (show 2D layout as if to be laser engraved)
 - 1 detail of a rendered perspective of the completed y-tube
- Laser engraved y-tube

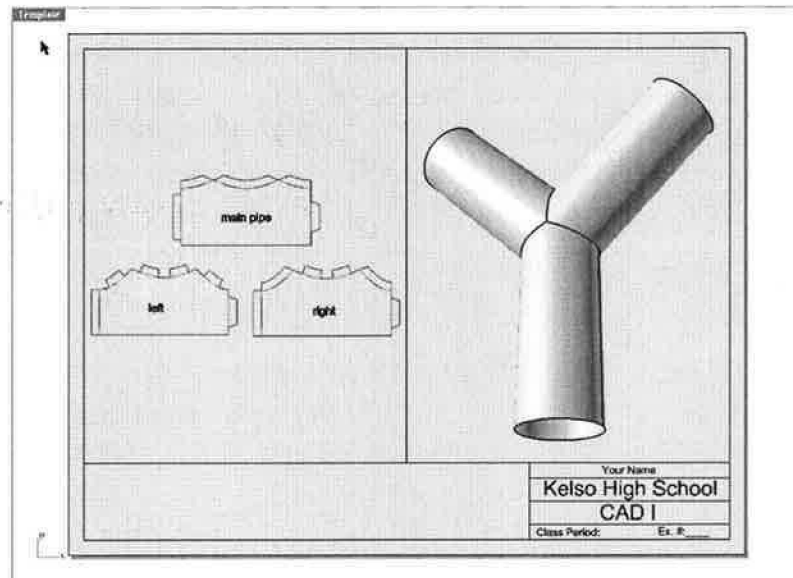

Figure 1a

Complete the Following Math Questions for the Y-tube Project
YOU MUST SHOW ALL MATH TO RECEIVE CREDIT!!!

1. Find the surface area for the following cylinder.



2. Find the amount of water needed to fill the cylinder up (use the cylinder above).
(volume in milliliters) _____

3. Using the flat layout of your y-tube, find the total surface area for your y-tube pieces
(ANALYZE with Rhino) (use inches).

4. Given that you cut your y-tube pieces out of 1 manila folder, what was the percentage
of waste you had? (careful- a manila folder is not a perfect rectangle)

5. If a box containing 50 manila folders cost \$4.12, then what does one folder cost?

6. Given that you know how much one folder cost and the percentage of waste for each
y-tube you cut, how much money goes to waste for each y-tube you cut?

Directions for the Y-tube Project

1. Measure a ball provided by teacher (use Pi Tape to determine diameter)
2. Using line segments, draw 3 lines that intersect as a "Y" (careful not to go too small as it will make it considerably difficult to assemble the finished product, figure 1a)

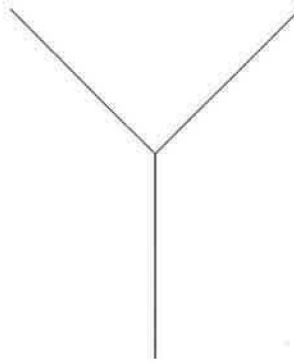

Figure 1a

3. Using the CIRCLE-AROUND CURVE command, draw a circle around the vertical line (use a diameter that will allow the ball to fit through the y-tube), figure 1b)



Figure 1b

4. Using the SURFACE-EXTRUDE CURVE-ALONG CURVE command, extrude the circle along the vertical line segment, figure 1c

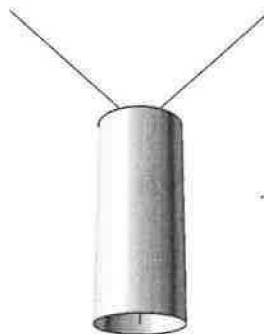

Figure 1c

5. Repeat steps 3 and 4 for the other two line segments, figure 1d

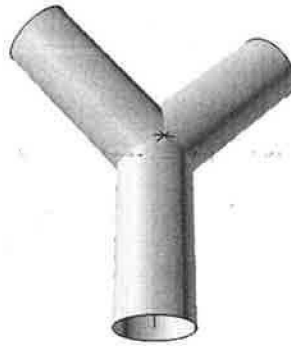

Figure 1d

6. HIDE curves
7. TRIM the surfaces (cylinders) where they intersect
8. JOIN the surfaces to create 1 polysurface
9. Use the SURFACE-UNROLL DEVELOPABLE SRF command to unroll the y-tube, figure 1e

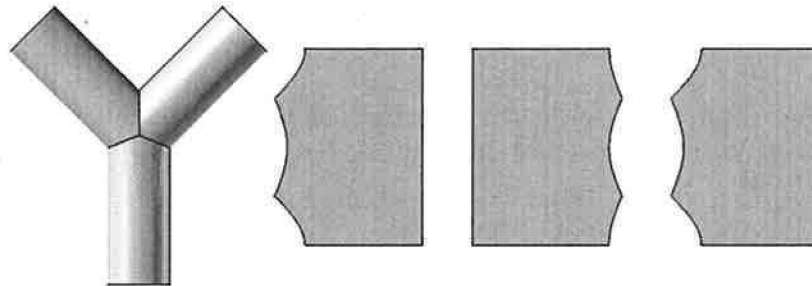

Figure 1e

10. HIDE the 3D y-tube
11. Create curves around the unrolled surfaces by using the CURVE-CURVE FROM OBJECT-DUPLICATE BORDER command
12. HIDE the unrolled surfaces, figure 1f

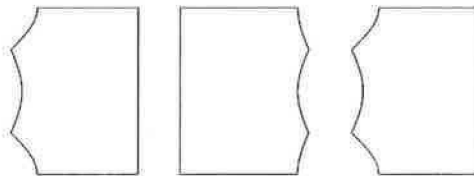

Figure 1f

13. Draw a tab system for the y-tube (bring in cereal, cracker, and other packaging boxes to look at for examples), figure 1g

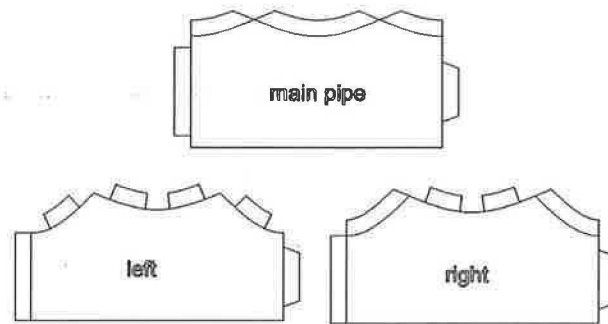

Figure 1g

14. Assign the appropriate layer colors to the y-tube pieces, figure 1h

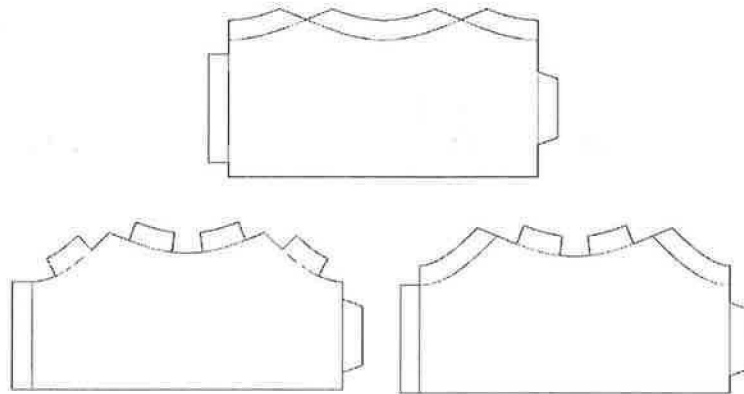

Figure 1h

15. Your y-tube is now ready to engrave or print out

Creating an Initial Inlay Using the Laser Engraver

Student Learning Targets

I can create an inlay given a set of parameters

- I will do this by using Rhino (CAD)
- I will work in both 2D and 3D space
- I will demonstrate this by creating an inlay that meets the given parameters

Design Parameters

- Inlay your initials into a piece of wood (capital letters)
- Initials must intersect
- Initials must fit on a 4" by 4" piece of material

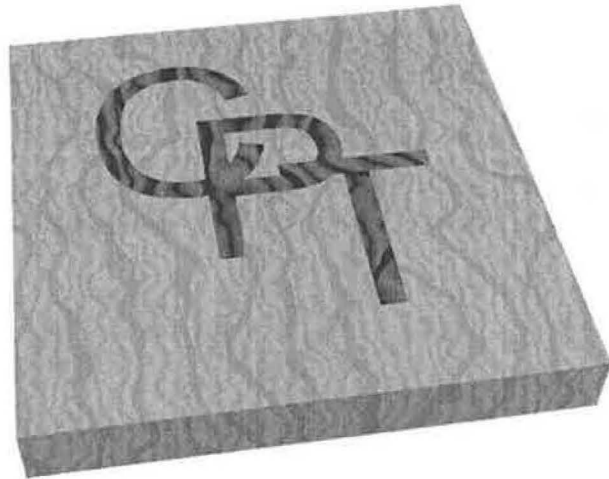

Learning Outcome

In this project the student will learn how to create a basic inlay using the laser engraver. The student will create a pocket using a raster cut, and will cut out the letters using a vector cut. This is a great project that one can do to learn how to create decorative art work

The Following Must be Turned in with the Initial Inlay Project

Turn in project in the following order

- Project cover page
- Completed math problems below
- Inlay with initials

Complete the Following Math Questions for the Initial Inlay Project
YOU MUST SHOW ALL MATH TO RECEIVE CREDIT!!!

1. Graph your initials to match your vector cutout
 - Must label X & Y axis to 1/8" increments
 - Must use compass & straight edge for ALL arcs, circles, and lines
 - Stock size= 4"x 4"

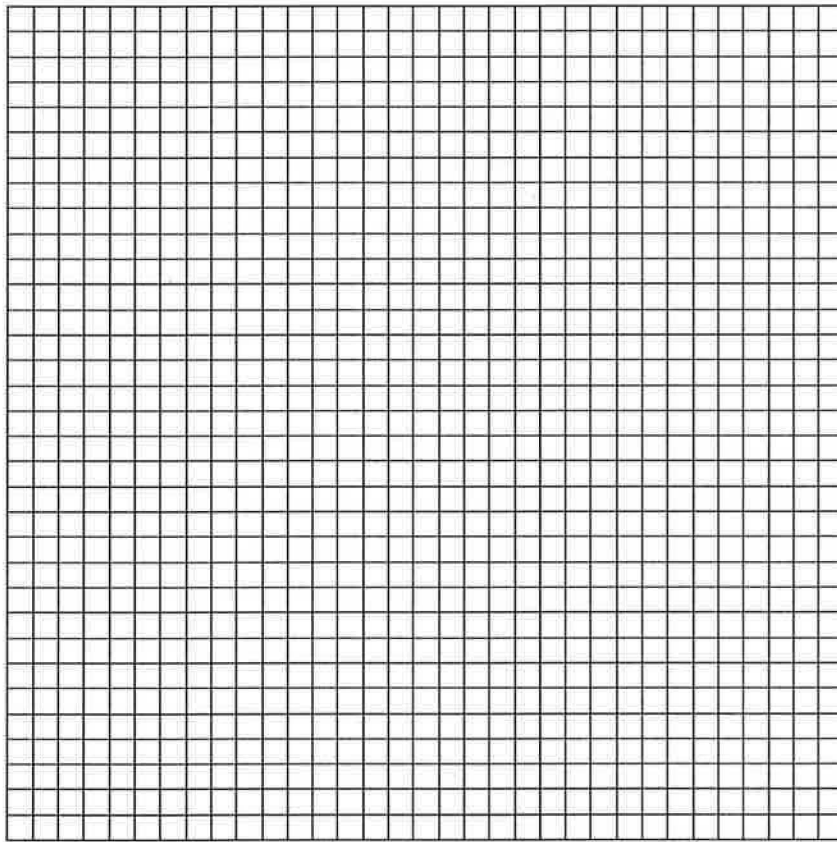

2. Using the space below, write G&M code for the initials you cut out

| | | | |
|-------|-------|-------|-------|
| _____ | _____ | _____ | _____ |
| _____ | _____ | _____ | _____ |
| _____ | _____ | _____ | _____ |
| _____ | _____ | _____ | _____ |
| _____ | _____ | _____ | _____ |

Directions for the Initial Inlay Project

To create a pocket for your initials do the following:

1. Draw a rectangle the size of the material
2. Create your initials in the center of the rectangle using curves (make sure they intersect and use **SOLID-TEXT-CURVES**), figure 1a

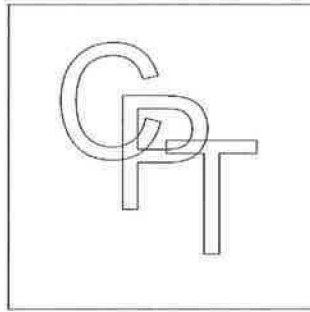

Figure 1a

3. **MAKE SURE YOU COPY YOUR ORIGINAL INITIALS ON A SEPARATE LAYER AND TURN THE NEW LAYER OFF**
4. Trim initials to create a pocket, figure 1b

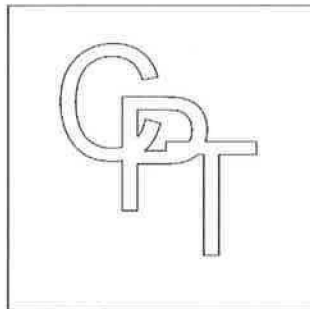

Figure 1b

5. Hide your rectangle
6. Use **SOLID-EXTRUDE PLANAR CURVE-STRAIGHT** to extrude your initials a tiny bit (you just need a surface or solid surface to raster- thickness is really not important), figure 1c



Figure 1c

7. Save your extruded initials as: pocket for initials
8. Raster your pocket with the laser engraver (initials must be black and raster must be selected on print options), figure 1d

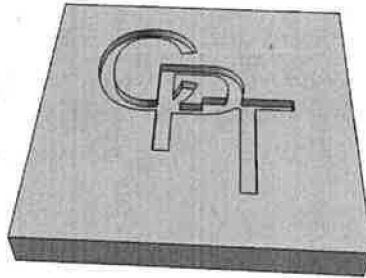

Figure 1d

To cut out your initials out of a veneer do the following:

1. Hide your work from creating the pocket
2. Turn on the layer you created above that contains your original initials
3. Trim your initials to create pieces you can cut to fit in your pocket, Figure 1e



Figure 1e

4. Save your initials (curves) as: cut out initials
5. Cut your initials using a vector cut with the laser engraver, figure 1f



Figure 1f

6. Clean the pocket up with a flat-head screw driver
7. Brush glue into the pocket
8. Place letter pieces into place and either hold into place with clear tape or put wax paper over letters and apply pressure with an object (you really want your letters a bit above the block that way the pressure is distributed over the letters and not the block)
9. Next day, sand the material flush and you should have a nice inlay, figure 1g

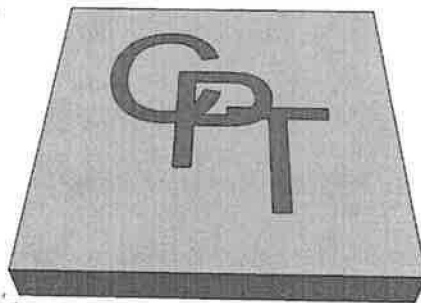

Figure 1g

Cutting a Lego Using the Laser Engraver

Student Learning Targets

I can create a Lego given a set of parameters

- I will do this by using Rhino (CAD)
- I will demonstrate this by creating a Lego that meets the given parameters
- This means I can accurately read a dial caliper
- This means I can convert from standard to metric units
- This means I can accurately use conversions, measuring, and scaling as it applies to this project

Project Parameters

- Using a dial caliper, measure a Lego to .001"
- Sketch a drawing with the measurements (top, front, right views)
- Use inches
- Use Rhino to draw a 2D drawing of top
- Build 3D model on a separate layer (do not model the bottom)
- Print 2D drawing of top at full scale using 1/8" acrylic and laser engraver (see below)
- Check fit with actual Lego

Perspective

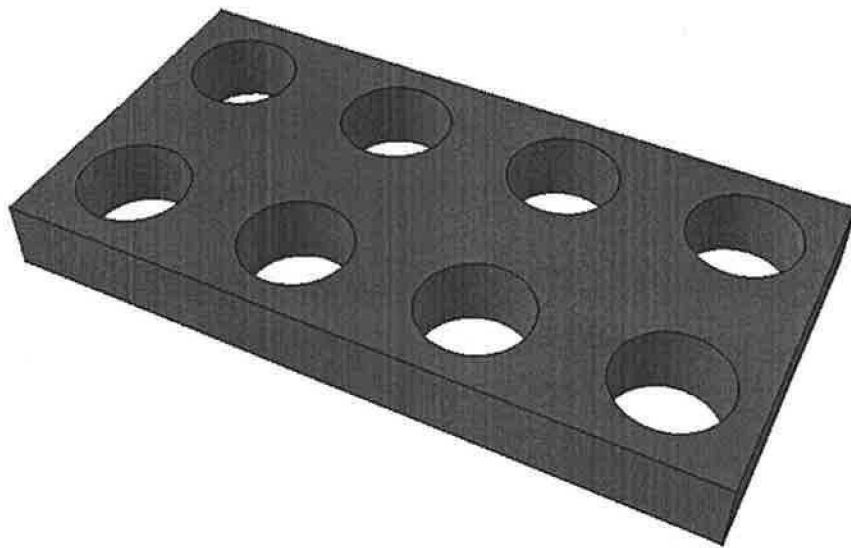

Learning Outcome

In this project the student will learn how to use a dial caliper for precision measuring. The student will understand the importance of precision measuring upon completion of the Lego project.

The Following Must be Turned in with the Lego Project

Turn in project in the following order

- Project cover page
- Completed math problems below
- Page layout of Lego (see figure 1a)
 - 1 detail of top view (show 2D layout as if to be laser engraved, show dimensions of Lego)
 - 1 detail of a rendered perspective
- Laser engraved Lego

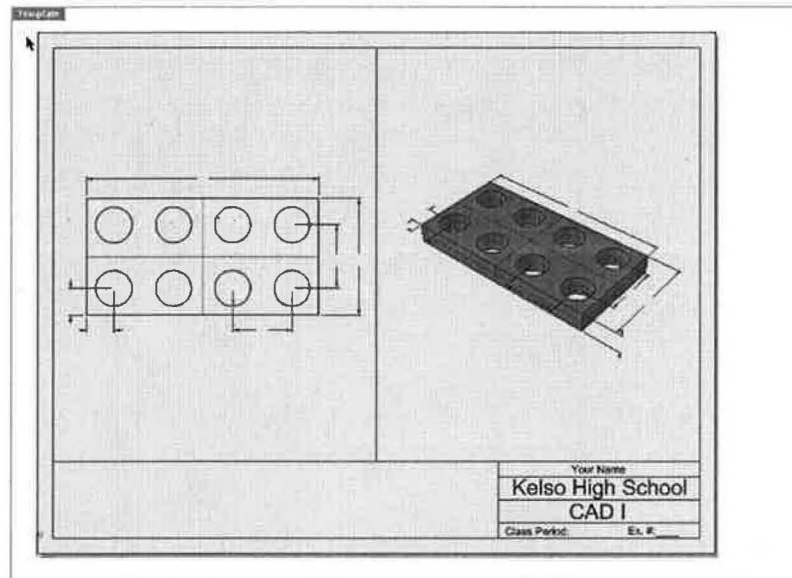
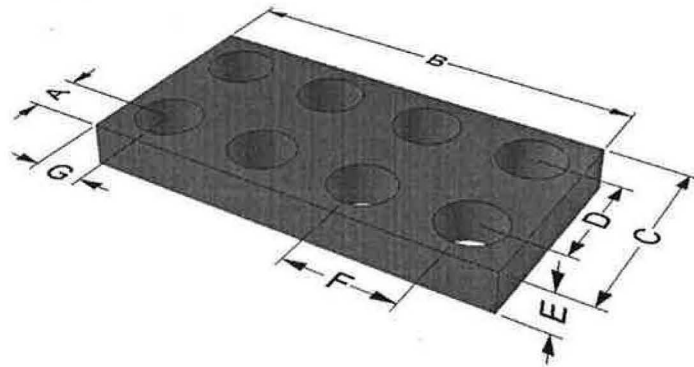

Figure 1a

Complete the Following Math Questions for the Lego Project YOU MUST SHOW ALL MATH TO RECEIVE CREDIT!!!

1. Your Lego was just scaled up by 7%. Fill in the dimension below to resemble what the new dimensions would be if the Lego was scaled up by that amount. (your piece was 1/8" thick to start with) (round to nearest 1000th using inches)



A= _____
 B= _____
 C= _____
 D= _____
 E= _____
 F= _____
 G= _____

2. Using the same scaled Lego, fill in the dimensions below to resemble the Lego using millimeters (round to nearest mm).

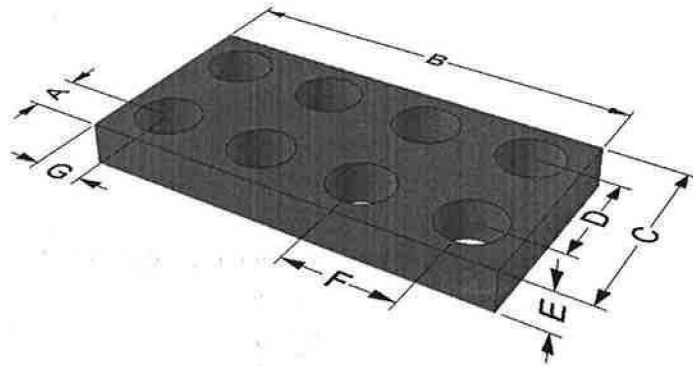

A= _____
 B= _____
 C= _____
 D= _____
 E= _____
 F= _____
 G= _____

3. Using millimeters, what is the volume of the Lego with the holes cut out? (round to nearest .001 mm)

Instructions for the Lego Assignment (Laser Engraver)

1. Using a dial caliper, measure a Lego to .001"
2. Using the RECTANGLE command, draw the top rectangle of the Lego, figure 1a



Figure 1a

3. EXPLODE the rectangle
4. Use OFFSET to layout the center of the Lego's circles, figure 1b

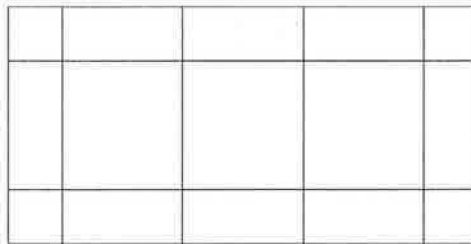

Figure 1b

5. Draw a CIRCLE according to the diameter you measured off the Lego, figure 1c

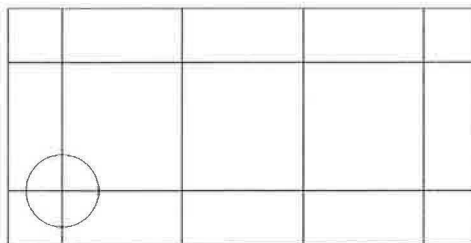

Figure 1c

6. COPY the circle to all the required locations, figure 1d

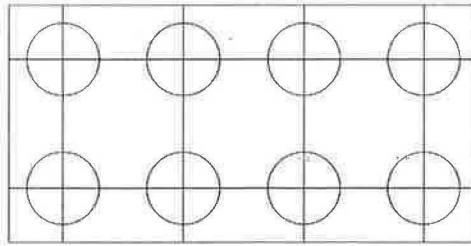

Figure 1d

7. HIDE the curves used for locating centers of circles, figure 1e

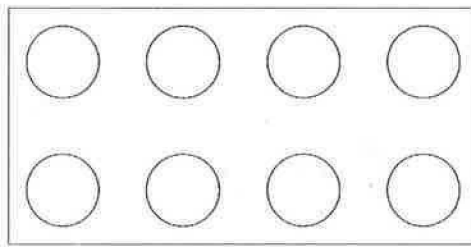

Figure 1e

8. Assign the appropriate layer colors to your Lego, figure 1f

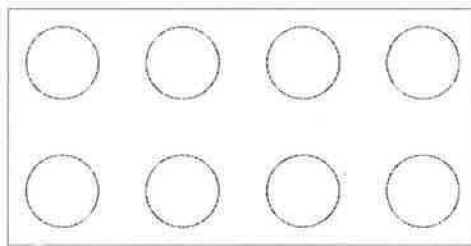

Figure 1f

9. Your Lego is now ready to be engraved or printed

Creating a Set of Gears Using the Laser Engraver

Student Learning Targets

I can create a set of gears given a set of parameters

- I will do this by using Rhino (CAD)
- I will demonstrate this by creating a set of gears that meet the given parameters.
- This means I can accurately read a dial caliper
- This means I can accurately use inches, diameter, ratio, and gear calculations as it applies to this project

Design Parameters (STEP 1)

- See teacher to get the gear ratio you will use for the project
- Using Rhino, draw 2 spur gears 2D using the following:
 - GearGen plug- in for Rhino-*public folder*
 - Gear ratio you were given
 - 20 degree pressure angle
 - Smallest gear has 16 teeth
- Create one page layout showing the following, figure 1a:
 - 2 gears their correct distance apart
 - Rotated to display they fit
 - Dimension the pitch diameter for each circle
 - Label each gear with the number of teeth they have

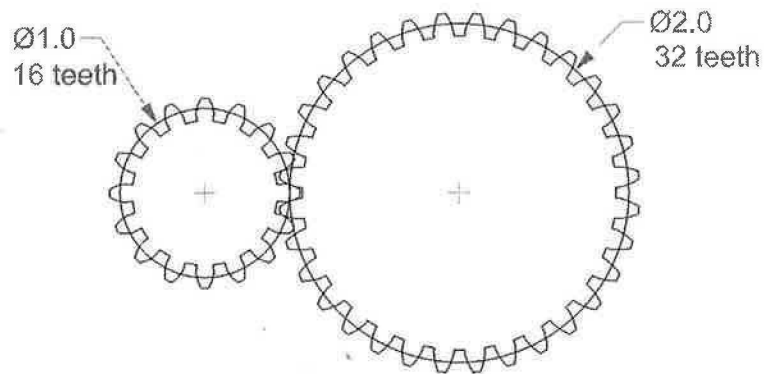

Figure 1a

Learning Outcome

In this project the student will be introduced to a spur gear. They will learn about gear ratios throughout the project and the importance of scaling an object to a specified size. The student will use precision measuring techniques to prepare their gears to fit on a Lego axel.

Design Parameters (STEP 2)

- See teacher to get the axel distance (location) to fit gears to, figure 1b
- Measure a Lego axel
- Draw Lego axel cut-outs on the 2 gears you already designed, figure 1c
- Scale the 2 gears so they fit the distance you were assigned above
- Cut the 2 gears separately out of a manila folder using the laser engraver
- Check gear fit with the Legos
- Once you think the gears fit, cut your final set out of 1/8" acrylic

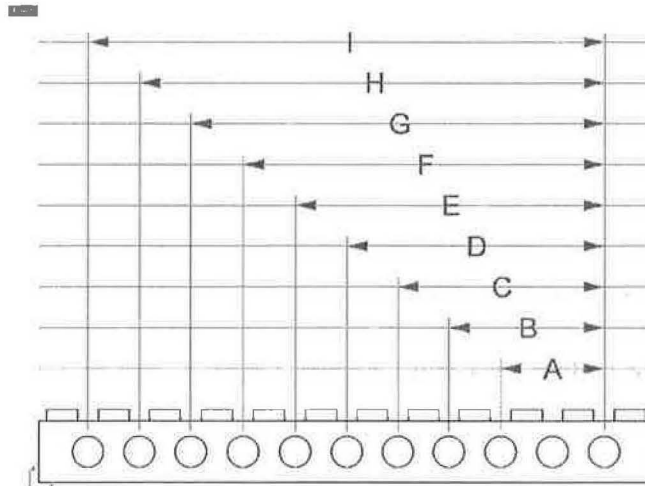

Figure 1b

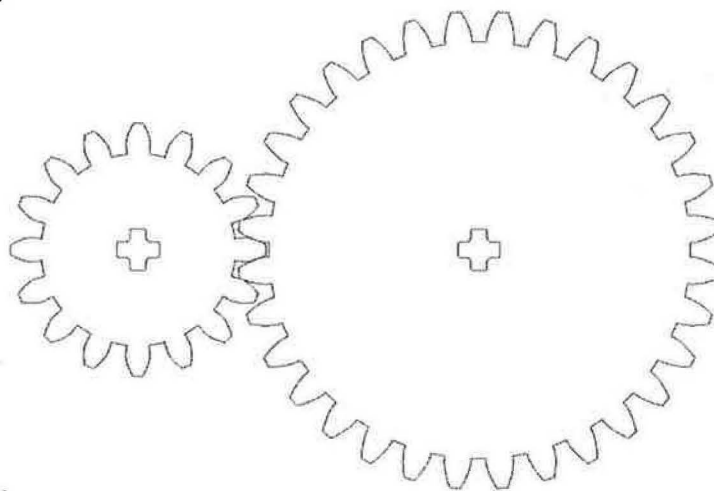

Figure 1c

The Following Must be Turned in with the Gear Project

Turn in project in the following order

- Project cover page
- Completed math problems below
- Page layout of gears (see figure 1d)
 - Center and scale 1 detail of front view in the middle of the page layout (show 2D layout of gears as they fit together using their correct distance, use 1:1 scale)
- Laser engraved gears

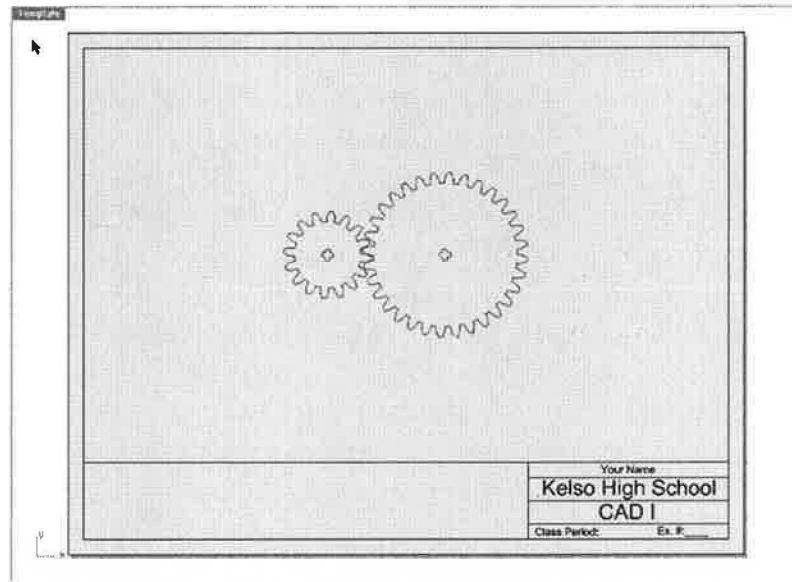

Figure 1d

Complete the Following Math Questions for the Gear Project YOU MUST SHOW ALL MATH TO RECEIVE CREDIT!!!

1. Using figure 1a below, if gear 1 rotates clockwise what direction will gear 4 rotate?

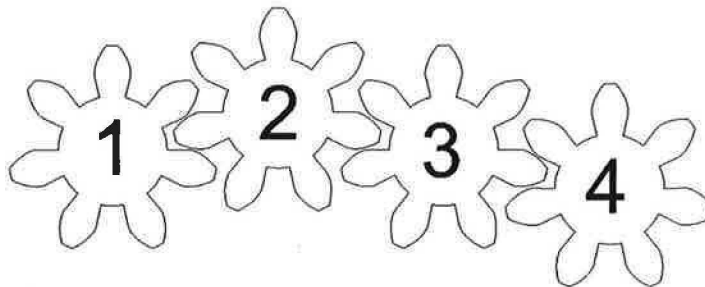

Figure 1a

2. Using figure 1b below, if gear 1 moves in a counterclockwise direction, which other gears will also turn counterclockwise? _____

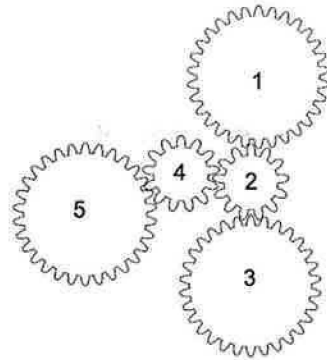

Figure 1b

3. Using figure 1c below, if gear 1 is turning right which direction will gear 3 turn (L or R)? _____

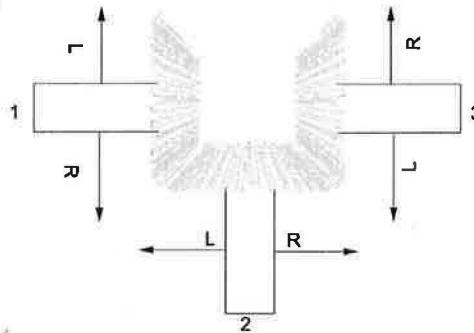

Figure 1c

4. Using figure 1d below, if gear 1 makes 20 complete counterclockwise revolutions per minute then how many revolutions will gear 2 make? What direction?

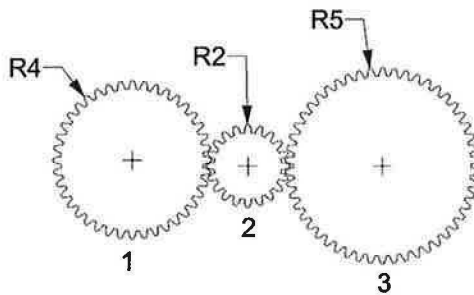

Figure 1d

5. Using figure 1e below, if gear 1 makes 10 complete counterclockwise revolutions per minute then how many revolutions will gear 3 make per minute?

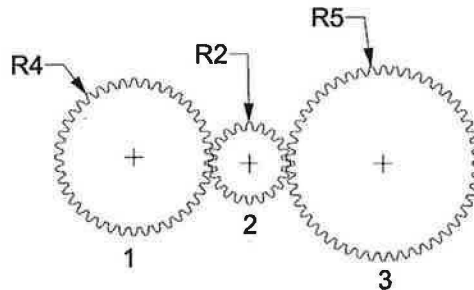

Figure 1e

Designing a Small Cabin for a Developer

Student Learning Targets

I can create a cabin given a set of parameters

- I will do this by using Rhino (CAD)
- I will work in both 2D and 3D space
- I will demonstrate this by creating a cabin that meets the given parameters
- This means I can accurately use estimating, floor plan, roof plan, and elevations as it applies to this project

Design Parameters

- MAXIMUM of 120 square feet
- Must be livable

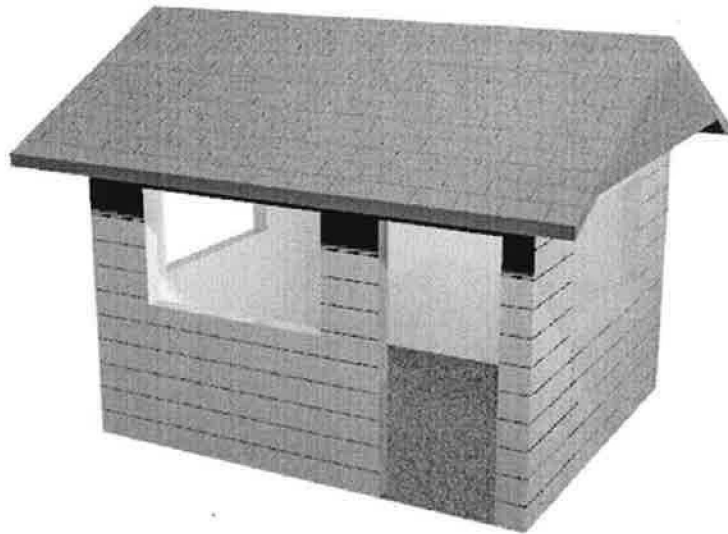

Learning Outcome

In this project the student will be introduced to some basic architecture terminology and techniques as they create a floor plan, roof plan, and elevations of a small cabin. The student will also learn how to scale a detail on a page layout. Solid modeling and rendering techniques will be used in this project as the student creates a realistic model of their cabin.

The Following Must be Turned in with the Cabin Project

Turn in project in the following order

- Project cover page
- Completed math problems below
- Page layout of a rendered perspective (show material properties-realistic look), figure 1a
- Page layout of floor plan (use $\frac{1}{2}''=1'$ scale), figure 1b
- Page layout of roof plan (use $\frac{1}{2}''=1'$ scale), figure 1c
- Page layout with 4 elevations (front, rear, right, left) (use $\frac{1}{4}''=1'$ scale), figure 1d
- Model of cabin (use laser engraver and $\frac{1}{8}''$ plywood)

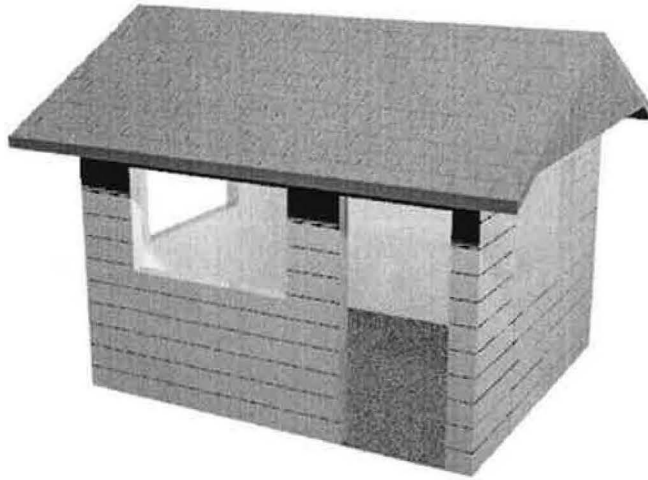

Figure 1a

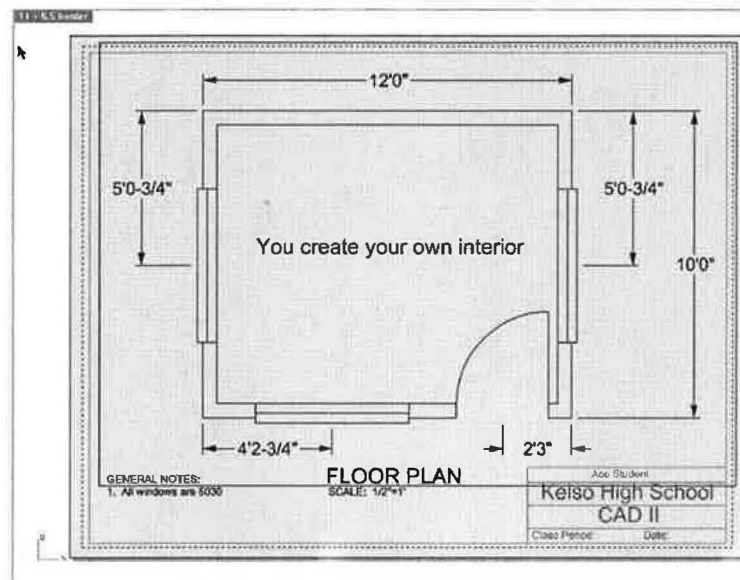

Figure 1b

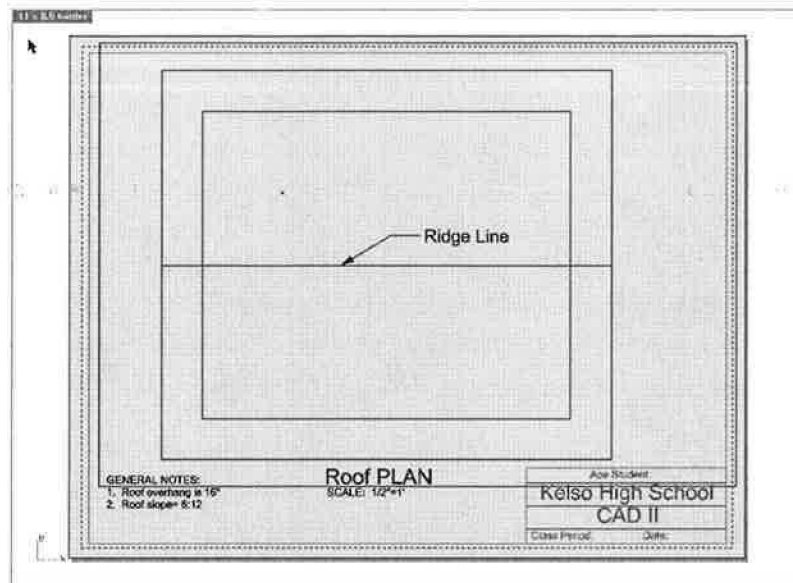

Figure 1c

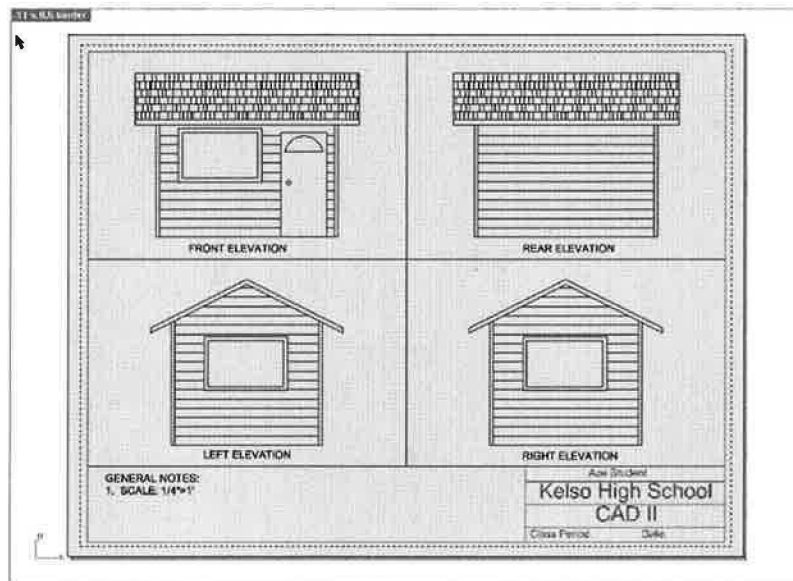

Figure 1d

**Complete the Following Math Questions for the Cabin Project
YOU MUST SHOW ALL MATH TO RECEIVE CREDIT!!!**

Exterior Walls

1. How many 4' x 8' sheets of plywood would you need to cover the exterior walls of your cabin?

2. If one piece of siding covers 1,044 square inches, how many pieces would you need to cover your entire cabin?

Roof

3. If a bundle of roofing covers 33 square feet, how many bundles of roofing would you need to roof your cabin?

Interior Walls

4. If one gallon of paint covers about 400 square feet, how many gallons would you use when painting your cabin (nearest 100th)?

Interior Floor

5. If carpet cost \$2.35 per square foot, how much would it cost to carpet the inside of your cabin? (round to nearest \$.01)

How to Create a 3D Model of Cabin

1. Complete your floor plan, Figure 1a

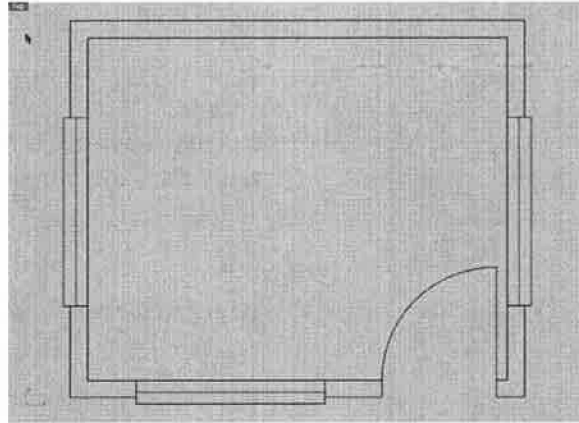

Figure 1a

2. Extrude walls up 8', Figure 1b

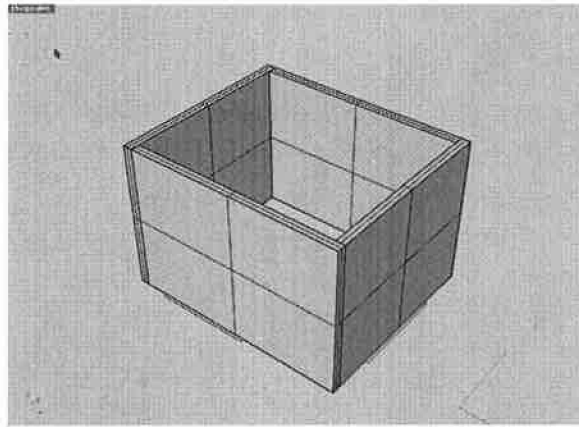

Figure 1b

3. Cut out windows and doors, (top of windows & doors= 6'10") Figure 1c

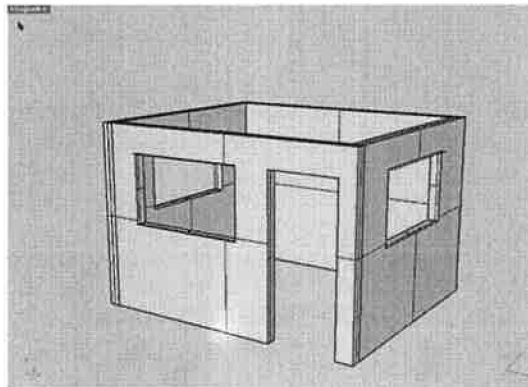

Figure 1c

4. Create floor with flat surface, Figure 1d

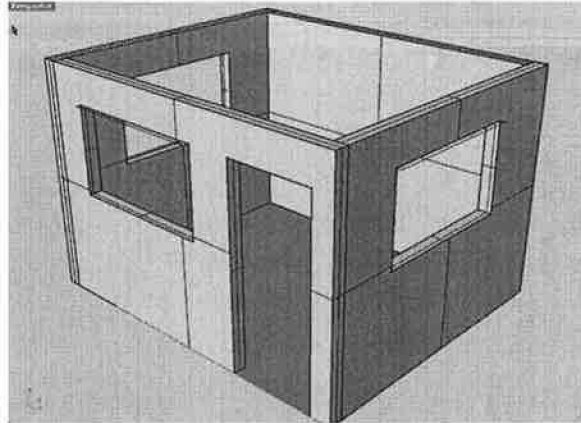

Figure 1d

5. Copy roof layout from wall section onto one of side walls, Figure 1e

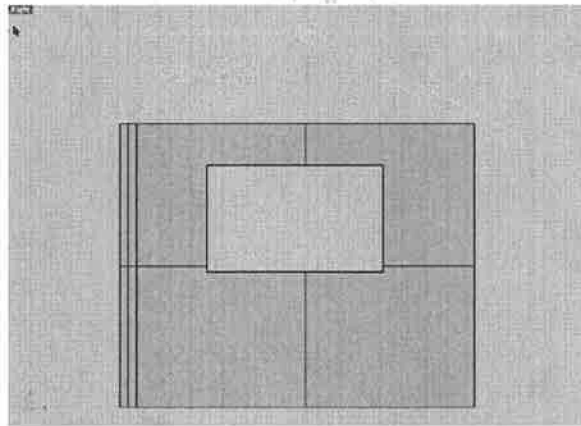

Figure 1e

6. Create two closed polylines as shown in Figure 1f

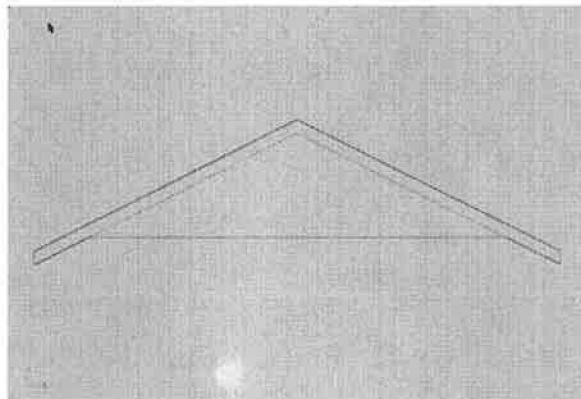

Figure 1f

7. Extrude bottom triangle of roof layout along one wall, Figure 1g

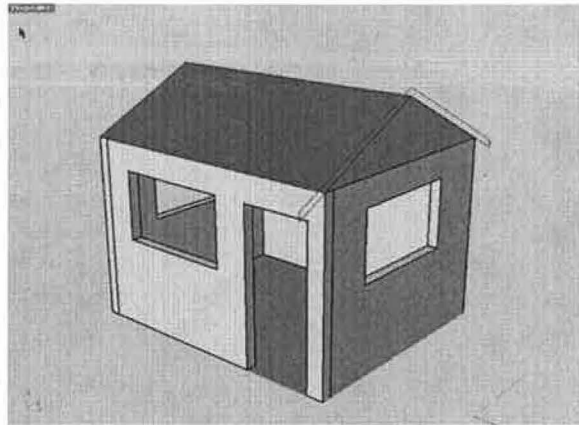

Figure 1g

8. Move your top roof layout curve out from the wall the distance you have included in your design, Figure 1h

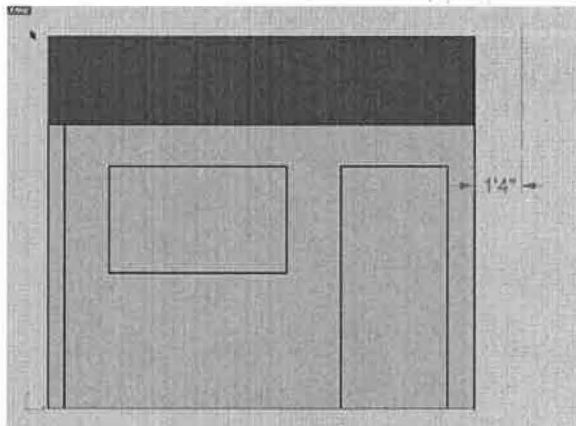

Figure 1h

9. Extrude the top roof layout curve the correct distance of your cabin roof, Figure 1i

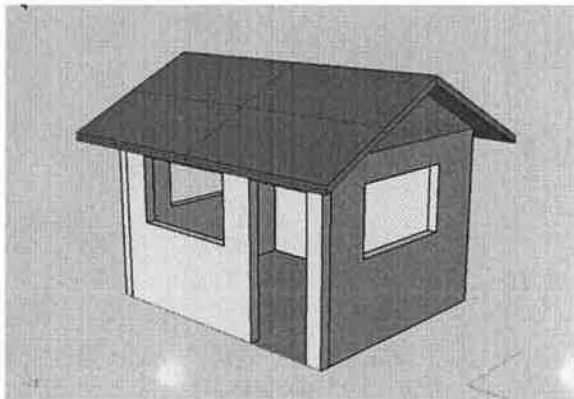

Figure 1i

10. Explode your polysurfaces so you can apply properties to both sides of the polysurfaces (example: you can apply siding to the outside of a wall and paint the inside of the same wall)
11. Be creative and make your cabin as realistic as you can!!!

How to Create an Elevation

Follow these steps:

1. Rotate floor plan to work on either right or left side (there is a reason you should create the right or left elevations prior to creating the front and rear, will discuss front & rear later)
2. Copy wall section from public folder and paste as shown in Figure 1a.

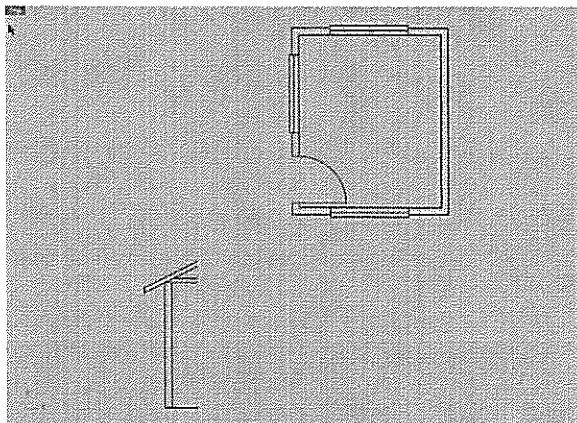

Figure 1a

3. Project lines down from floor plan (outside of walls, windows, doors), Figure 1b.

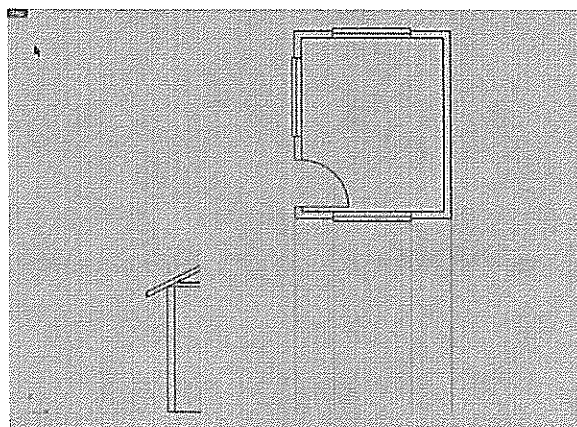

Figure 1b

4. Project lines across from wall section (floor, end of rafter tail), Figure 1c

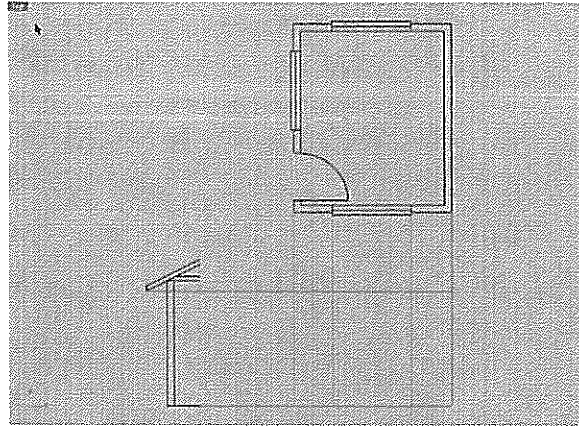

Figure 1c

5. Copy wall section to the correct location, Figure 1d

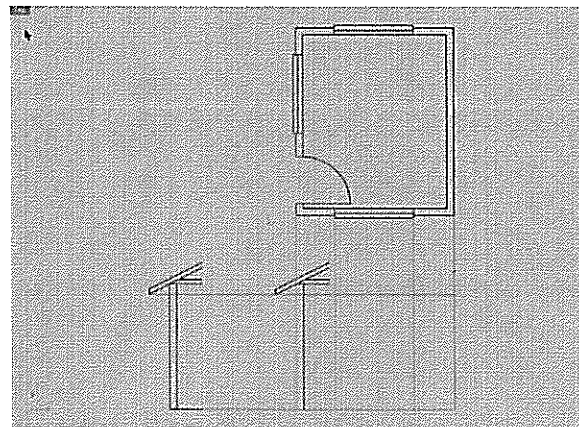

Figure 1d

6. Trim wall section, Figure 1e

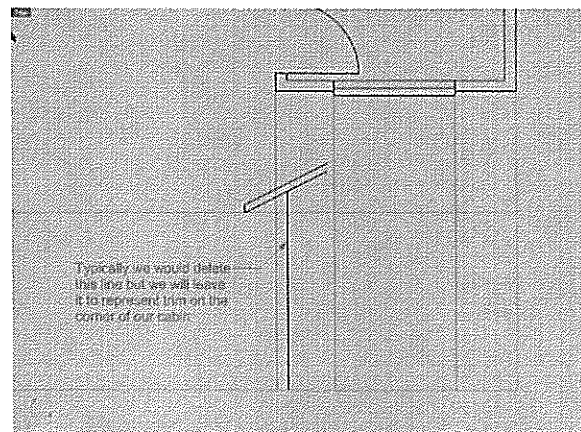

Figure 1e

7. Extend wall section to midpoint of wall or elevation, Figure 1f

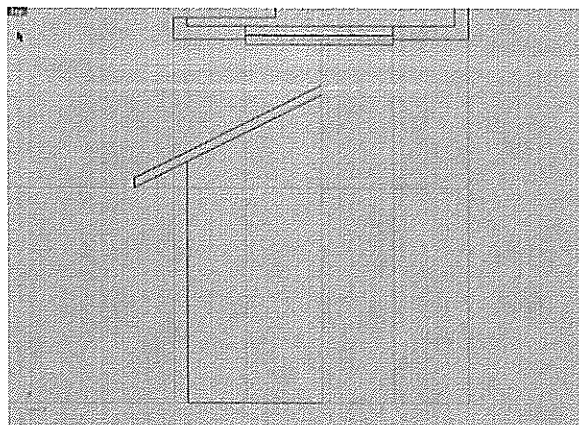

Figure 1f

8. Mirror wall section to other side of wall or elevation, Figure 1g

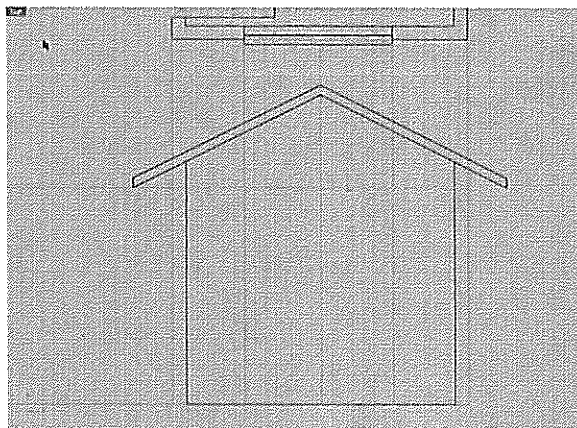

Figure 1g

9. Copy floor line up 6'10" to layout top of window(s) or door(s), Figure 1h

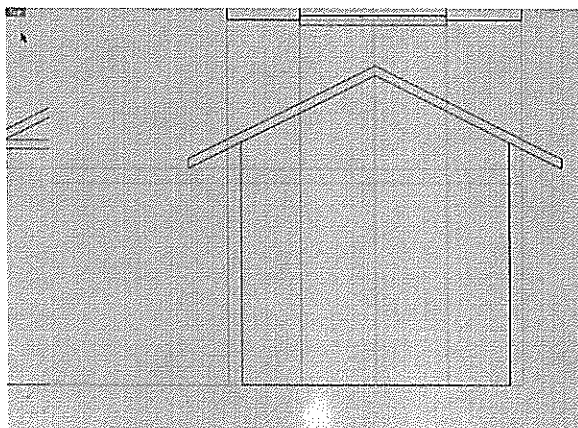

Figure 1h

10. Copy the top of window line down the height(s) of the window(s), Figure 1i

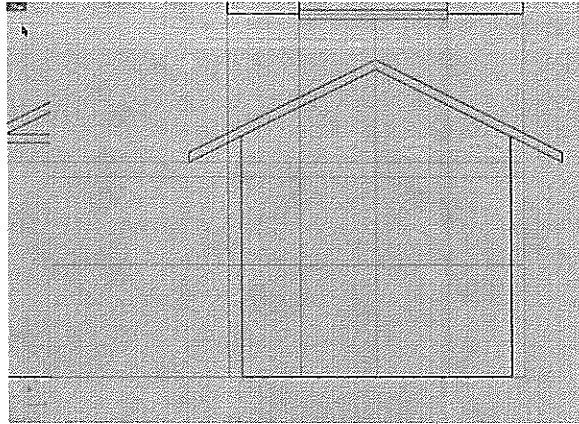

Figure 1i

11. Use line or polyline command to draw window(s) and doors, turn off projection lines to see elevation, Figure 1j

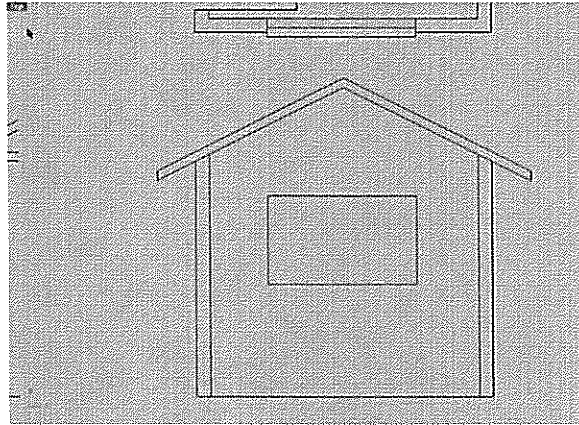

Figure 1j

12. Copy bottom line up the width you want your siding, trim lines up as shown in Figure 1k

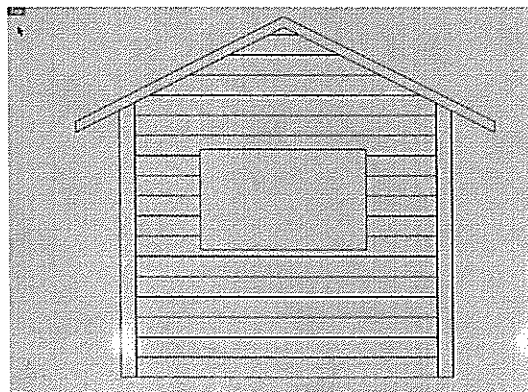

Figure 1k

13. Add trim around doors and windows as needed, Figure 11

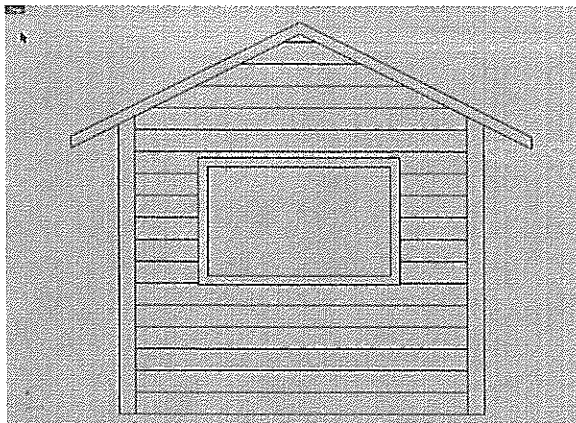

Figure 11

14. Add any extras you want to dress up your elevation.

15. To create front and rear elevations see below.

How to Create Front and Rear Elevations

1. Copy wall section from public folder and paste as shown in Figure 1a.

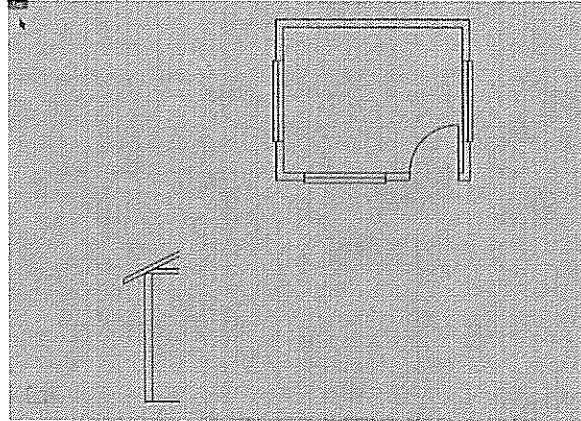

Figure 1a

2. Project lines down from floor plan (outside of walls, windows, doors), Figure 1b.

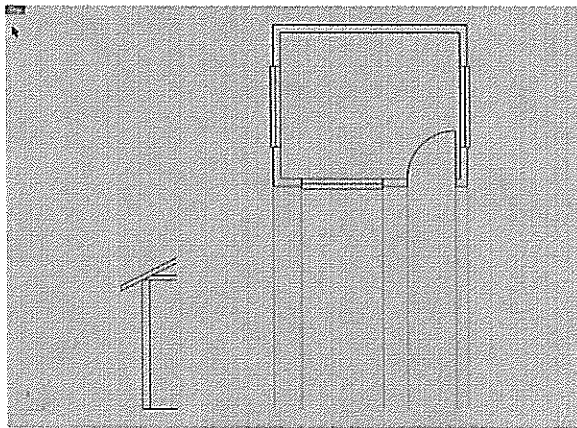

Figure 1b

3. Offset the outside lines outwards the distance of your roof overhang, Figure 1c

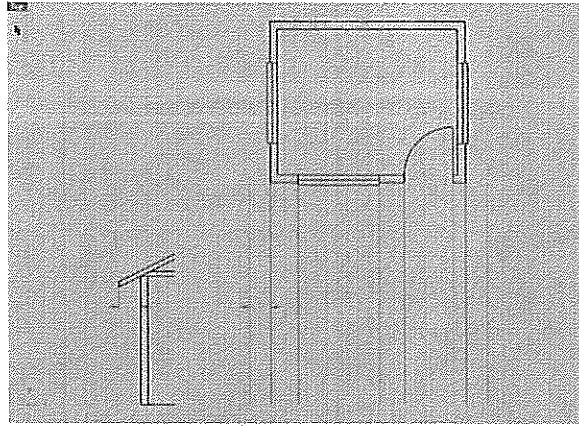

Figure 1c

4. Project lines across from wall section (floor, end of rafter tail), Figure 1d

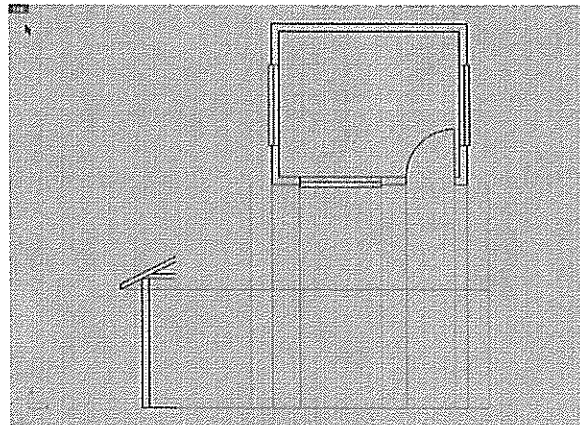
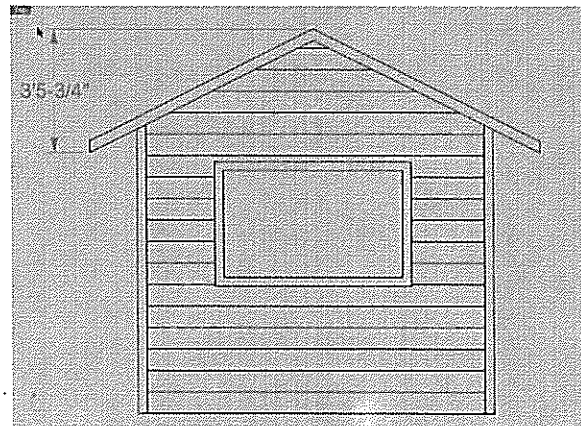
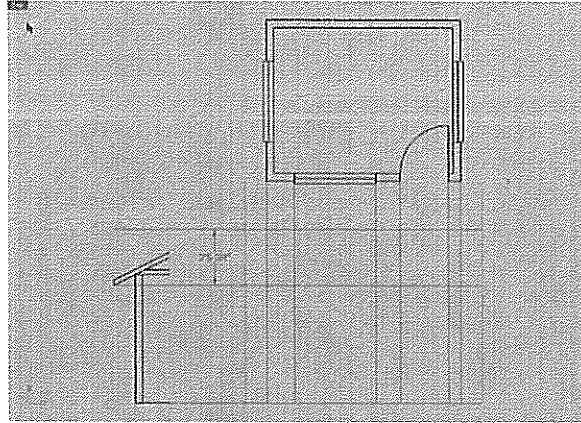

Figure 1d

5. Offset the “end of rafter tail projection line” up the height of your roof (previously determined when you created your right and left elevations) see below





6. Use the line or polyline command to create the outline of the roof and cabin, figure 1e

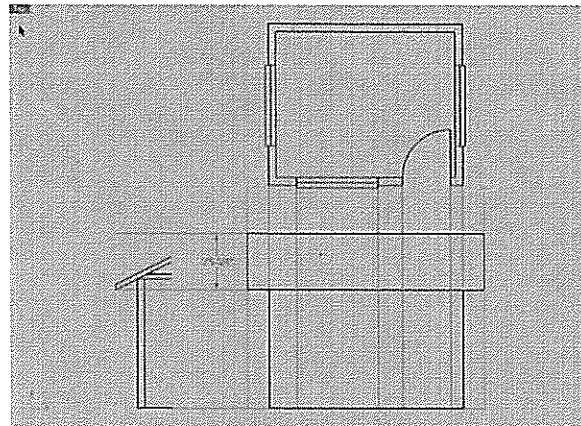

Figure 1e

7. Copy floor line up 6'10" to layout top of window(s) or door(s), Figure 1f

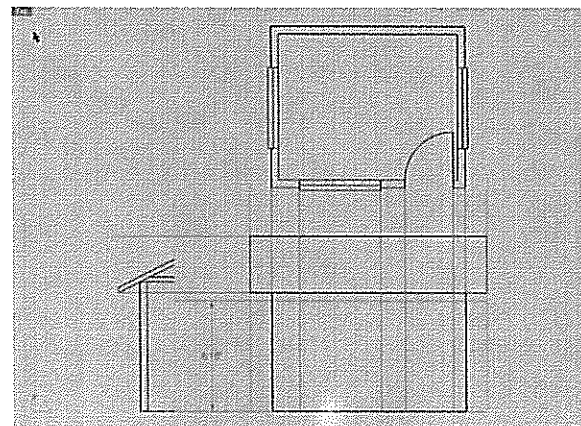

Figure 1f

8. Copy the top of window line down the height(s) of the window(s), Figure 1g

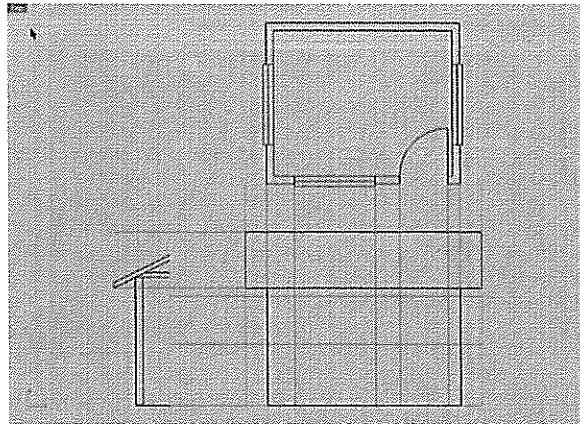

Figure 1g

9. Use line or polyline command to draw window(s) and doors, turn off projection lines to see elevation, Figure 1h

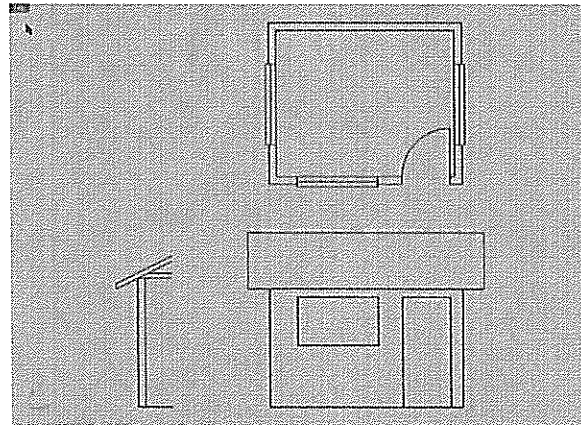

Figure 1h

10. See instructions above to layout siding, place trim on corners of cabin, place trim around doors and windows, etc.

Creating a Page Layout for Elevations

The biggest issue is the UNITS settings, make sure the units are in INCHES

Setting up a Page Layout

1. Start a new model. Select the template file called "11x8.5 architecture"
2. Click the "11x8.5 Border" Tab at the bottom of the page. You will see the Border and title ready to go.
3. Once you have created your Elevation in the Top-Viewport, or copy and pasted your Elevation into the Top-Viewport of the new template file, Right-Click the "11x8.5 Border" page tab and pick "Insert New Detail."
4. Drag the rectangle to the size of detail you want. You can always turn on the control points to resize the new detail box to fit your needs.

Scaling your Elevations

1. To scale your Elevation make sure the "11x8.5 border" viewport is NOT active. Click the edge of the detail to select it.
2. Select Object Properties, change object to detail, and choose a scale that will work for your layout. (1:12= 1"=1', 1:24= 1/2"=1', 1:48=1/4"=1', 1:96= 1/8"=1')
THEN LOCK YOUR SCALE (you can still size and move it, but its scale will NOT change on the sheet)

Adding Text

1. With the Page Layout detail NOT active, from the Dimension menu, select Text Block
2. Pick a start point, then set text height. .125" or .25" text height is a good height for labeling.

To Plot

1. Select the correct printer for the job
2. Select Landscape
3. Select the correct viewport and make sure PAGE is selected, not extents
4. Scale= 1:1 (you already scaled the detail)
5. Print

CHAPTER II

MILLING MACHINE PROJECTS

Purpose of the Milling Machine Projects

Much like the laser engraver, the milling machine projects were designed to teach students how to create a project given a set of parameters. The first few G&M code projects were designed to help students make the connection between the X,Y,Z coordinate system and how it is relevant to the project and the machining process. Students are also introduced to the tools, toolpaths, stepdowns, offsets, material sizes, G&M codes, and graphing techniques needed to understand the basics of NC programming. The G&M code projects help prepare students for using CAM software and help them trouble shoot code if they need to in the future.

The CAD/CAM projects used with the milling machine were designed to teach students how to use a CAM software to simulate toolpaths from a CAD drawing and be able to safely and accurately operate a CNC milling machine. The projects were also created to teach students about precision measuring, the importance of being able to read technical drawings, and be able to design for manufacturability. If a drawing is off a thousandth of an inch the part may not work. Also, a student may design a project that they think is great until they try to machine it and find out they cannot do so. Their problem may be because they did not figure their math right for the size of the part, the cutter size, or take into account the capability of the machine they are using. All of the skills listed are relevant to student learning and parallel industry. The milling machine projects force students to think and plan more then they have had to in their beginning

CAD course(s). They also force students to pay close attention to detail. All in all, the milling machine projects teach students many skills that are transferable to industry and may peak an interest in a engineering or CAD related career for some students.

G & M Code Handout

The following are a list of G & M codes you will use to write CNC code for your next few projects:

G-CODES:

G00 Position in rapid

- Used to move tool linearly without cutting any material
- Z moves are on separate line then XY moves
- NOT TO BE USED FOR CUTTING

G01 Linear interpolation

- Straight-line feed moves
- Linear removal of material with any combination of X, Y, Z

G02 Circular interpolation (CW)

- Radial feed moves for making quadratic arcs, partial arcs, or complete circles
- Requires an endpoint and radius in order to cut an arc
- 2 ways to draw arcs

Method 1

- ✓ enter X and Y endpoints and then R for radius
- ✓ use of R value for radius of arc is limited to 90 degrees
- ✓ see example: G01 X2 Y4 (start point of arc)
G02 X4 Y2 R2

Method 2

- ✓ find radius by measuring relative(incremental) distance from start point to center point
- ✓ radius is assigned variables I and J
- ✓ I is the X value
- ✓ J is the Y value
- ✓ to find radius values make a chart:

| | | | |
|--------------|----|-----|-------------------|
| Center point | X2 | Y2 | G01 X2 Y4 (start) |
| Start point | X2 | Y4 | G02 X4 Y2 I0 J-2 |
| Radius | I0 | J-2 | |

G03 Circular interpolation (CCW)

- SAME RULES APPLY AS FOR G02
- ✓ See example: G01 X4 Y1 (start point of arc)
G03 X1 Y4 R3

- ✓ See example: Center point X1 Y1 G01 X4 Y1 (start)
- Start point X4 Y1 G03 X1 Y4 I-3 J0
- Radius I-3 J0

M-CODES:

- Only 1 M-CODE per line

M02 Program end

- Last line of program (end of cycle)

M03 Spindle on clockwise

- Switches spindle on clockwise
- Spindle speed (S) is followed by spindle speed rpm on the same line as M03
- To determine speed one needs to look up the material being cut, cutter used, material removal, etc. in a Machinist's handbook
- Example: M03 S1200 (means spindle is turned on at a speed of 1200rpm's)

M05 Spindle stop

- Turns spindle off
- Command is found at end of program

M06 Tool change

- Stops all machine operations
- Machine changes the tool

To write CNC Codes for your following assignments follow the 3-step process below:

Step 1: Program set up (prepare machine for operation)

- Turn spindle on and include rpm M03 S1200

Step 2: Material removal (cutting feed moves)

- Rapid X, Y from origin G00 X_ Y_
- Rapid down Z to .1" above part G00 Z.1
- Feed down into part to required depth for cut pass G01 Z-._
- Feed X, Y G01 X_ Y_
- Rapid up Z to .1 (clear the part) G00 Z.1
- Rapid back home X0, Y0 G00 X0 Y0

Step 3: System shut down (turn off the options that were turned on in Step 1 and end)

- Turn spindle off M05
- End of program M02

Graph & Write G & M Code for a Square Part

Student Learning Targets

I can graph and write G&M code for a part given a set of parameters

- I will do this by using graph paper
- I will demonstrate this by graphing and writing G&M code for the square part given a set of parameters
- This means I can accurately graph and write G&M code for a part

Assignment Instructions

- Must first graph the part
- Graph the object on graph paper (graph paper is attached below)
- Must label X and Y axis on graph
- Must label incremental value of $\frac{1}{4}$ "
- Must write G & M code for machining the part

Design Parameters

- Stock size= 2" x 3"
- Cutter= $\frac{1}{8}$ " end mill
- Depth of cut= $\frac{1}{8}$ "

 TOP

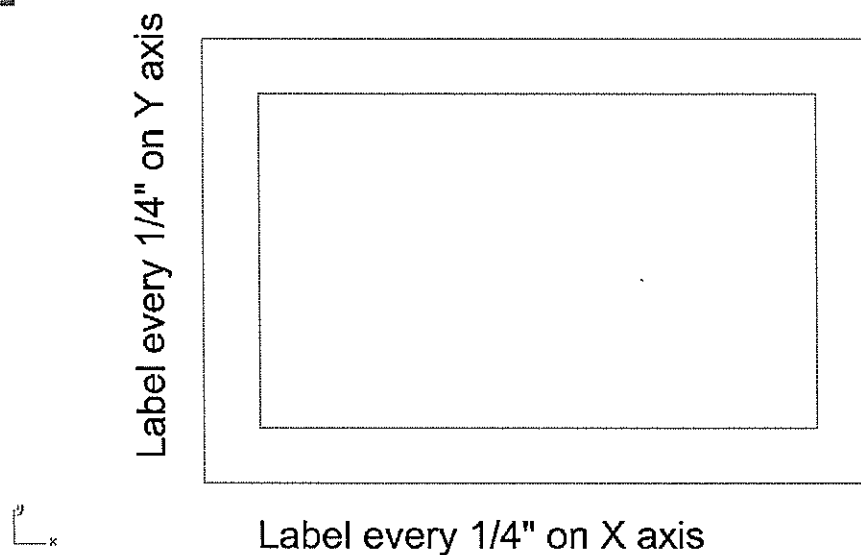

Learning Outcome

In this project the student will learn how to write G&M code. The G&M code is a standard form of code that Numerical Control (NC) machinery operates from. Knowing G&M code will help students with the graphing techniques needed to understand the basics of NC programming, and will help them troubleshoot code if they need to in the future.

Graph & Write G & M Code for the House Part

Student Learning Targets

I can graph and write G&M code for a part given a set of parameters

- I will do this by using graph paper
- I will demonstrate this by graphing and writing G&M code for the house part given a set of parameters
- This means I can accurately graph and write G&M code for a part

Assignment Instructions

- Must first graph the part
- Graph the object on graph paper (graph paper is attached below)
- Must label X and Y axis on graph
- Must label incremental value of $\frac{1}{4}$ "
- Must write G & M code for machining the part

Design Parameters

- Stock size= 2" x 3"
- Cutter= $\frac{1}{8}$ " end mill
- Depth of cut= $\frac{1}{8}$ "

 top

Label every $\frac{1}{4}$ " on Y axis

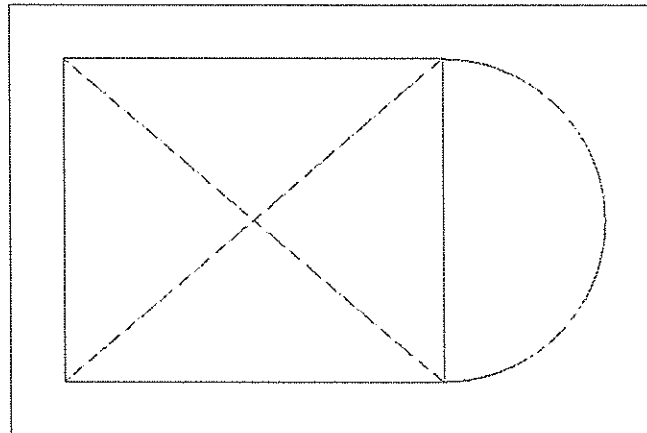



Label every $\frac{1}{4}$ " on X axis

Learning Outcome

In this project the student will learn how to write G&M code. The G&M code is a standard form of code that Numerical Control (NC) machinery operates from. Knowing G&M code will help students with the graphing techniques needed to understand the basics of NC programming, and will help them troubleshoot code if they need to in the future.

Graph & Write G & M Code for the Square-Circle-Triangle (Male) Part

Student Learning Targets

I can graph and write G&M code for a part given a set of parameters

- I will do this by using graph paper
- I will demonstrate this by graphing and writing G&M code for the square-circle-triangle male part given a set of parameters
- This means I can accurately graph and write G&M code for a part

Assignment Instructions

- Must first graph the part
- Graph the object on graph paper (graph paper is attached below)
- Must label X and Y axis on graph
- Must label incremental value of 1/8"
- Must write G & M code for machining the MALE part

Design Parameters

- Stock size= 2" x 3"
- Cutter= 1/2" end mill
- Depth of cut= 1/8"
- Triangle (top), circle (middle), square (bottom)

 Stop

Label every 1/8" on Y axis

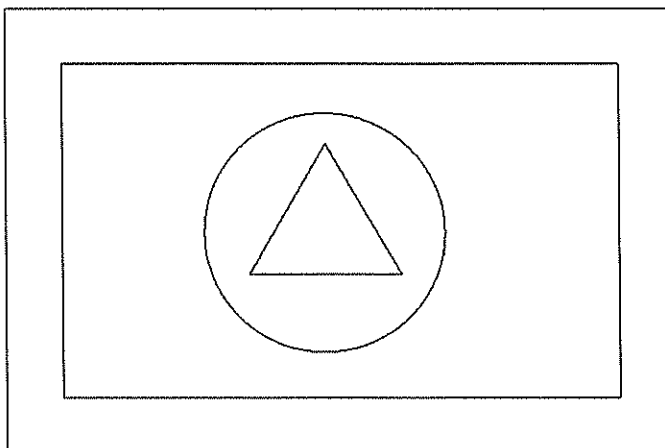

 x y

Label every 1/8" on X axis

Learning Outcome

In this project the student will learn how to write G&M code. The G&M code is a standard form of code that Numerical Control (NC) machinery operates from. Knowing G&M code will help students with the graphing techniques needed to understand the basics of NC programming, and will help them troubleshoot code if they need to in the future.

Graph & Write G & M Code for the Name Part

Student Learning Targets

I can graph and write G&M code for a part given a set of parameters

- I will do this by using graph paper
- I will demonstrate this by graphing and writing G&M code for the name part given a set of parameters
- This means I can accurately graph and write G&M code for a part

Assignment Instructions

- Must first graph the part
- Graph the object on graph paper (graph paper is attached below)
- Must label X and Y axis on graph
- Must label incremental value of 1/8"
- Must write G & M code for machining the part

Design Parameters

- Stock size= 2" x 3"
- Cutter= 1/8" end mill
- Depth of cut= 1/8"
- Only 2 capital letters

TOP

Label every 1/8" on Y axis

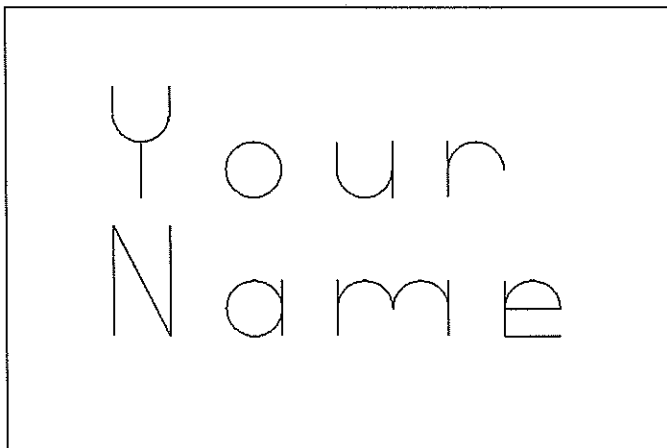

Y
X

Label every 1/8" on X axis

Learning Outcome

In this project the student will learn how to write G&M code. The G&M code is a standard form of code that Numerical Control (NC) machinery operates from. Knowing G&M code will help students with the graphing techniques needed to understand the basics of NC programming, and will help them troubleshoot code if they need to in the future.

Creating Square-Circle-Triangle Male & Female Parts Using the Milling Machine

Student Learning Targets

I can create square-circle-triangle male and female parts given a set of parameters

- I will do this by using Rhino (CAD)
- I will do this by using PartWorks (CAM)
- I will demonstrate this by creating two square-circle-triangle mating parts that meet the given parameters
- This means I can accurately generate toolpaths
- This means I can accurately and safely operate a CNC milling machine

Design Parameters

- Must cut male and female square, circle, triangle parts using the ShopBot
- Must fit on an 2" x 3" piece of 3/4" thick machinable wax
- Must use 1/8" step downs
- Must cut both male and female parts with one cutter
- Must use Rhino to create 2D drawing (CAD)
- Must use PartWorks to create toolpaths (CAM)
- If your completed male and female parts do not fit, then REDO

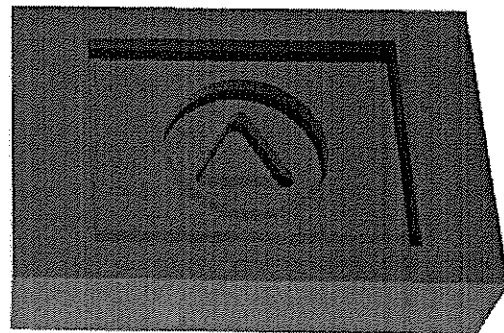
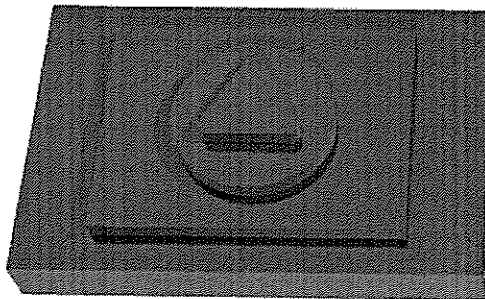

Learning Outcome

In this project the student will learn how to use pocketing and/or profiling toolpaths to create a set of mating parts. By doing so the student will learn about the importance of tolerances.

The Following Must be Turned in with the Square-Circle-Triangle-Male/Female Project

Turn in project in the following order

- Project cover page
- Completed math problems below (there is a pre-machining activity)
- Machined male and female parts

Complete the Following Math Questions for the Square-Circle-Triangle-Male/Female Project

YOU MUST SHOW ALL MATH TO RECEIVE CREDIT!!!

Pre-machining activity (complete for both male and female parts)

1. Determine the displacement of water for the rough block of material you are starting with. To do this do the following:

- Fill a beaker with 500 mL of water
- Place your material/part into the beaker
- Record the reading of the beaker below (nearest mL)

Male Part

Record your water level here: ___ mL

Female Part

Record your water level here: ___ mL

2. In your own words, write a prediction for which block will have more material removed when machined and why?

Post-machining activity (complete for both male and female parts)

1. Determine the displacement of water for the machined block of material.

Male Part

Record your water level here: ___ mL

Female Part

Record your water level here: ___ mL

2. Determine the volume of material that was removed from both blocks of material (round to nearest .001 cubic inches)

Male Part

Directions for the Square-Circle-Triangle Male and Female Parts

1. Draw a 3" x 2" RECTANGLE (this is the size of the stock), figure 1a

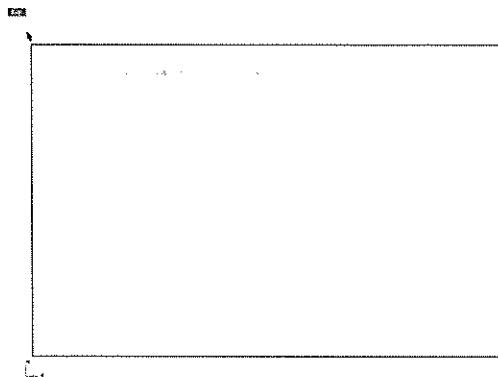

Figure 1a

2. Draw a RECTANGLE, CIRCLE, and TRIANGLE inside the 3" x 2" RECTANGLE, figure 1b

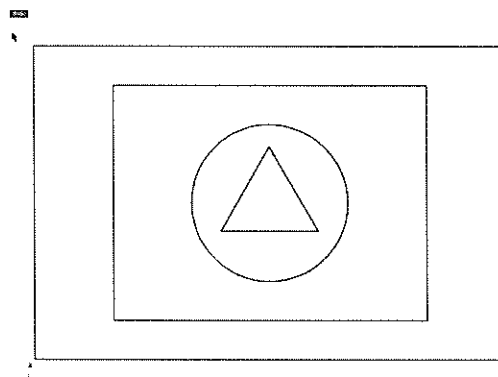

Figure 1b

3. FILLET all corners of the inner rectangle and triangle, (radius of fillet is equal to radius of cutter used), figure 1c

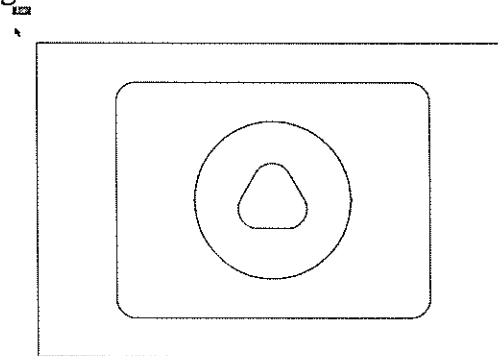

Figure 1c

4. Save the drawing
5. Save the drawing a second time as a dxf file (dxf files are commonly used with CAM software)
6. Use your CAM software to cut the male part (use the same drawing to cut both the male and female parts)
7. Import your dxf file into your CAM program (these steps will not be the same for all CAD/CAM software)
8. OFFSET the larger rectangle outward the radius of the cutter (this rectangle will be used as a boundary for creating pockets to ensure the entire outside of block is being machined), figure 1d

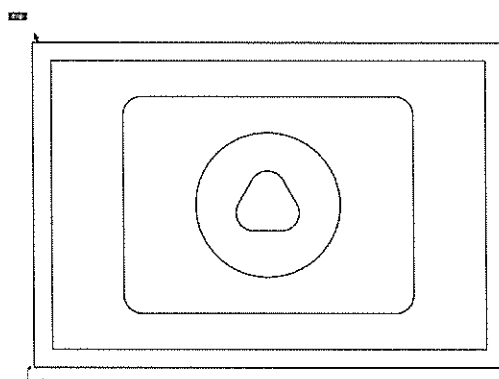

Figure 1d

9. Create a 1/8" deep POCKET TOOLPATH using a 1/4" end mill and the outside rectangle and triangle as the boundaries, figure 1e

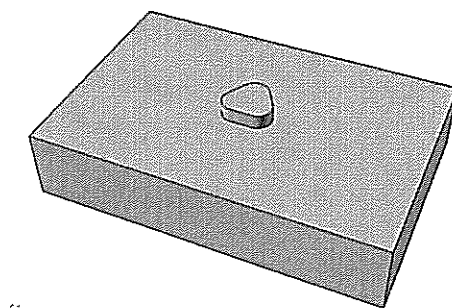

Figure 1e

10. Starting at a depth of 1/8", create a 1/8" deep POCKET TOOLPATH using a 1/4" end mill and the outside rectangle and circle as the boundaries (as a beginner it may be easier to use a start depth of 0 and create a pocket 1/4" deep), figure 1f

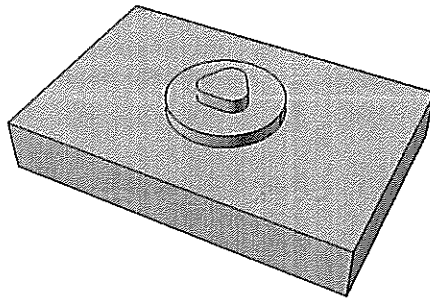

Figure 1f

11. Starting at a depth of $\frac{1}{4}$ ", create a $\frac{1}{8}$ " deep POCKET TOOLPATH using a $\frac{1}{4}$ " end mill and the outside rectangle and the inner rectangle as the boundaries (you could also use a start depth of 0 and create a pocket $\frac{3}{8}$ " deep), figure 1g

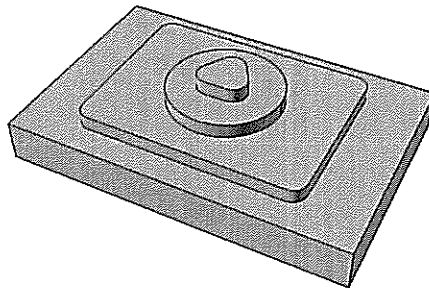

Figure 1g

12. Your toolpaths for the male part are now complete. Using a post processor, save the toolpaths in the order of which they should be run.

13. To cut the female part, re-import your original dxf file into your CAM program

14. Create a $\frac{1}{8}$ " deep POCKET TOOLPATH using a $\frac{1}{4}$ " end mill and the inside rectangle as the boundary, figure 1h

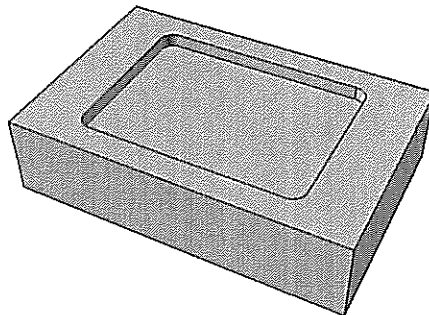

Figure 1h

15. Starting at a depth of 1/8", create a 1/8" deep POCKET TOOLPATH using a 1/4" end mill and the circle as the boundary (as a beginner it may be easier to use a start depth of 0 and create a pocket 1/4" deep), figure 1i

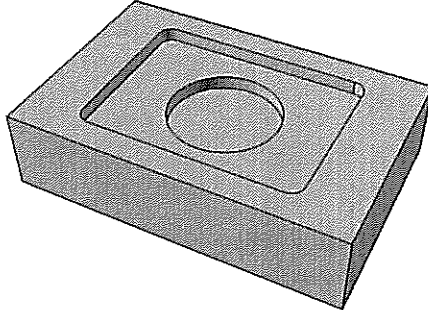

Figure 1i

16. Starting at a depth of 1/4", create a 1/8" deep POCKET TOOLPATH using a 1/4" end mill and the triangle as the boundary (you could also use a start depth of 0 and create a pocket 3/8" deep), figure 1j

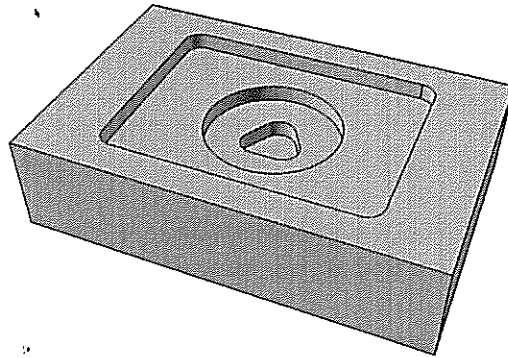

Figure 1j

17. Your toolpaths for the female part are now complete. Using a post processor, save the toolpaths in the order of which they should be run.

18. Once you have machined both parts, check to see if they fit

Creating a Key Chain Using the Milling Machine

Student Learning Targets

I can create a key chain given a set of parameters

- I will do this by using Rhino (CAD)
- I will do this by using PartWorks (CAM)
- I will demonstrate this by creating a key chain that meets the given parameters
- This means I can accurately read a technical drawing
- This means I can accurately generate toolpaths
- This means I can accurately and safely operate a CNC milling machine

Design Parameters

- Must cut the key chain provided using the ShopBot
- Must fit on an 2" x 3" piece of 3/4" thick material
- Must use 1/8" step downs
- Must use Rhino to create 2D drawing (CAD)
- Must use PartWorks to create toolpaths (CAM)
- If your completed key chain does not fit the answer key, then REDO

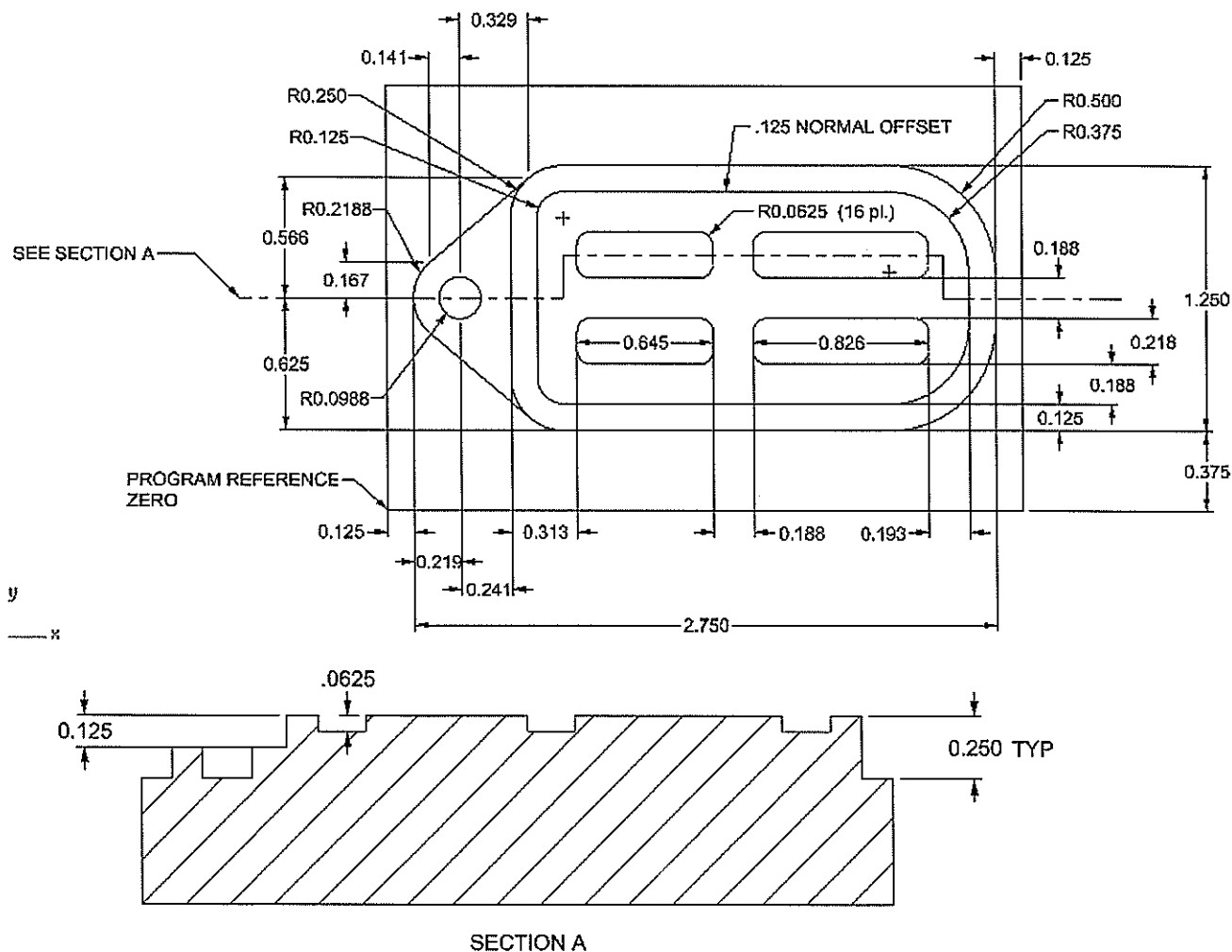

Learning Outcome

In this project the student will learn how to read a technical drawing. The student will have to accurately read a section view drawing to be able to determine cutting depths for the part.

The Following Must be Turned in with the Keychain Project

Turn in project in the following order

- Project cover page
- Completed math problems below
- Page layout of keychain
 - 2D with quality dimensioning techniques
- Machined keychain

Complete the Following Math Questions for the Keychain Project
YOU MUST SHOW ALL MATH TO RECEIVE CREDIT!!!

1. If you were machining a pocket with a $\frac{1}{4}$ " diameter bit, how small would the fillet be in the corners of the block you were machining, figure 1a?

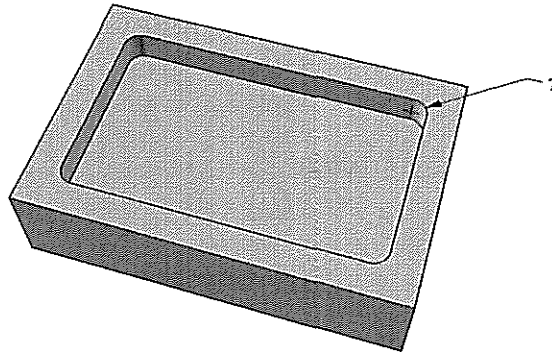

figure 1a

2. If you were machining with a $\frac{1}{4}$ " diameter bit and you set your stepover to .1 inches, what percent of the bit would step over with each pass?

3. Which method would be a faster way of cleaning the top of a 2" x 3" block (explain). Method A= $\frac{1}{4}$ " bit with a 50% step over or Method B= $\frac{1}{8}$ " bit with a 100% stepover

4. How many passes would it take a $\frac{1}{4}$ " diameter bit set up with a 50% stepover to clean off the ENTIRE top of a 2" x 3" block if the bit was traveling as shown below?, figure 1b

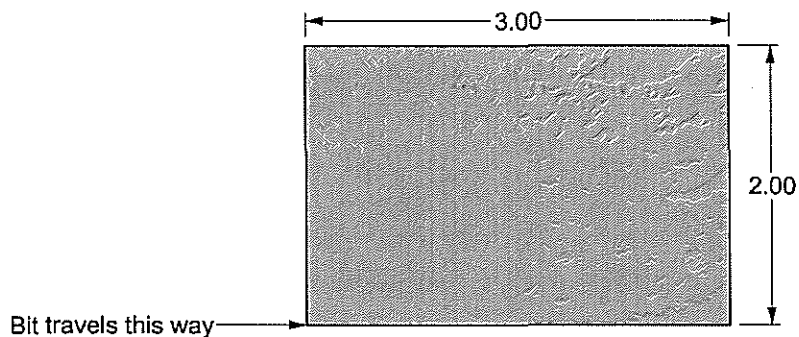

Figure 1b

5. What would 1.75 inches per second convert to in mm per second (nearest .01)?

6. Which is a faster feed rate, 1.75 inches per sec or 8.75 feet per min?

Directions for machining key chain

1. Draw the key chain in the center of a 3" x 2" rectangle as shown on handout, figure 1a

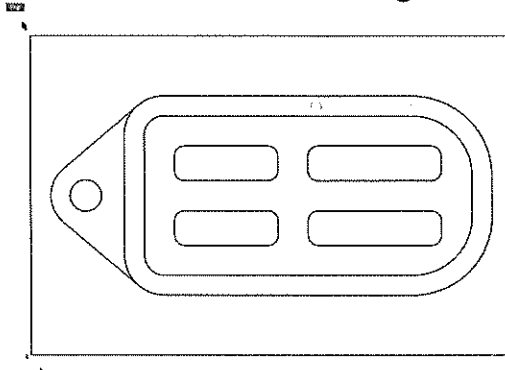

Figure 1a

2. Save the drawing
3. Save the drawing a second time as a dxf file (dxf files are commonly used with CAM software)
4. Use your CAM software to machine the key chain
5. Import your dxf file into your CAM program (these steps will not be the same for all CAD/CAM software)
6. Select the inner curves of the key chain, figure 1b

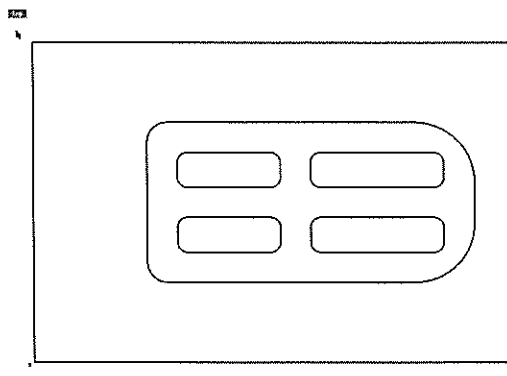

Figure 1b

7. Create a 1/16" deep POCKET TOOLPATH using a 1/8" end mill and the inner curves (figure 1b) as the boundaries, figure 1c

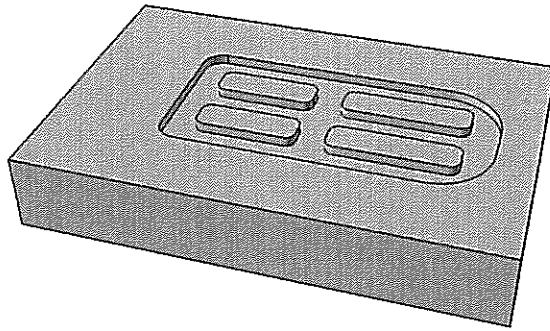

Figure 1c

8. OFFSET the 3" x 2" rectangle outward 1/8", figure 1d

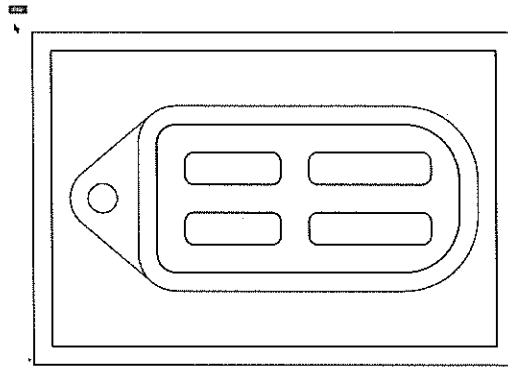

Figure 1d

9. Select the curves shown in figure 1e

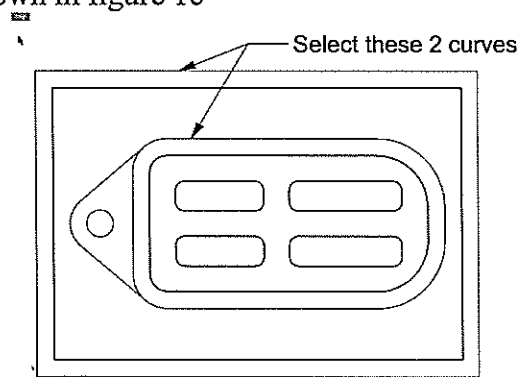

Figure 1e

10. Create a 1/8" deep POCKET TOOLPATH using a 1/8" end mill and the curves selected above as boundaries, figure 1e

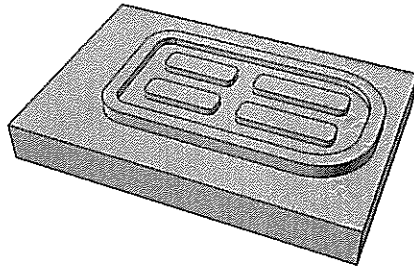

Figure 1e

11. Starting at a depth of 1/8", create a 1/8" deep POCKET TOOLPATH using a 1/8" end mill and the entire outside of the key chain and the outer rectangle as the boundaries (as a beginner it may be easier to use a start depth of 0 and create a pocket 1/4" deep), figure 1f

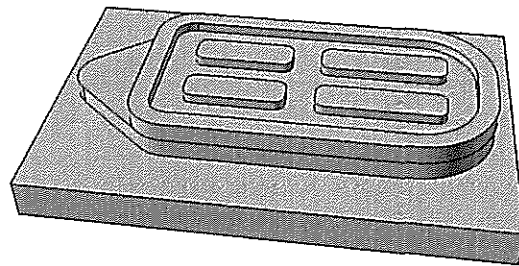

Figure 1f

12. Starting at a depth of 1/8", create a 1/8" deep POCKET TOOLPATH using a 1/8" end mill and the circle as the boundary (you could also use a start depth of 0 and create a pocket 1/4" deep), figure 1g

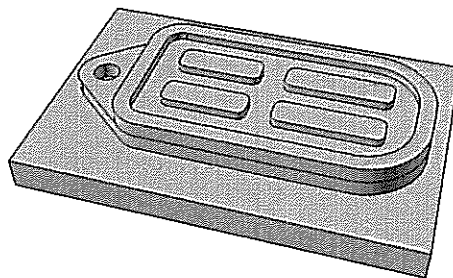

Figure 1g

13. Your toolpaths for the key chain are now complete. Using a post processor, save the toolpaths in the order of which they should be run.

Creating a Calculator Using the Milling Machine

Student Learning Targets

I can create a calculator given a set of parameters

- I will do this by using Rhino (CAD)
- I will do this by using PartWorks (CAM)
- I will demonstrate this by creating a calculator that meets the given parameters
- This means I can accurately read a technical drawing
- This means I can accurately generate toolpaths
- This means I can accurately and safely operate a CNC milling machine

Design Parameters

- Must cut the calculator provided using the ShopBot
- Must fit on a 3" x 5" piece of 3/4" thick material
- Must use 1/8" step downs
- Must use Rhino to create 2D drawing (CAD)
- Must use PartWorks to create toolpaths (CAM)
- If your completed calculator does not fit the answer key, then REDO

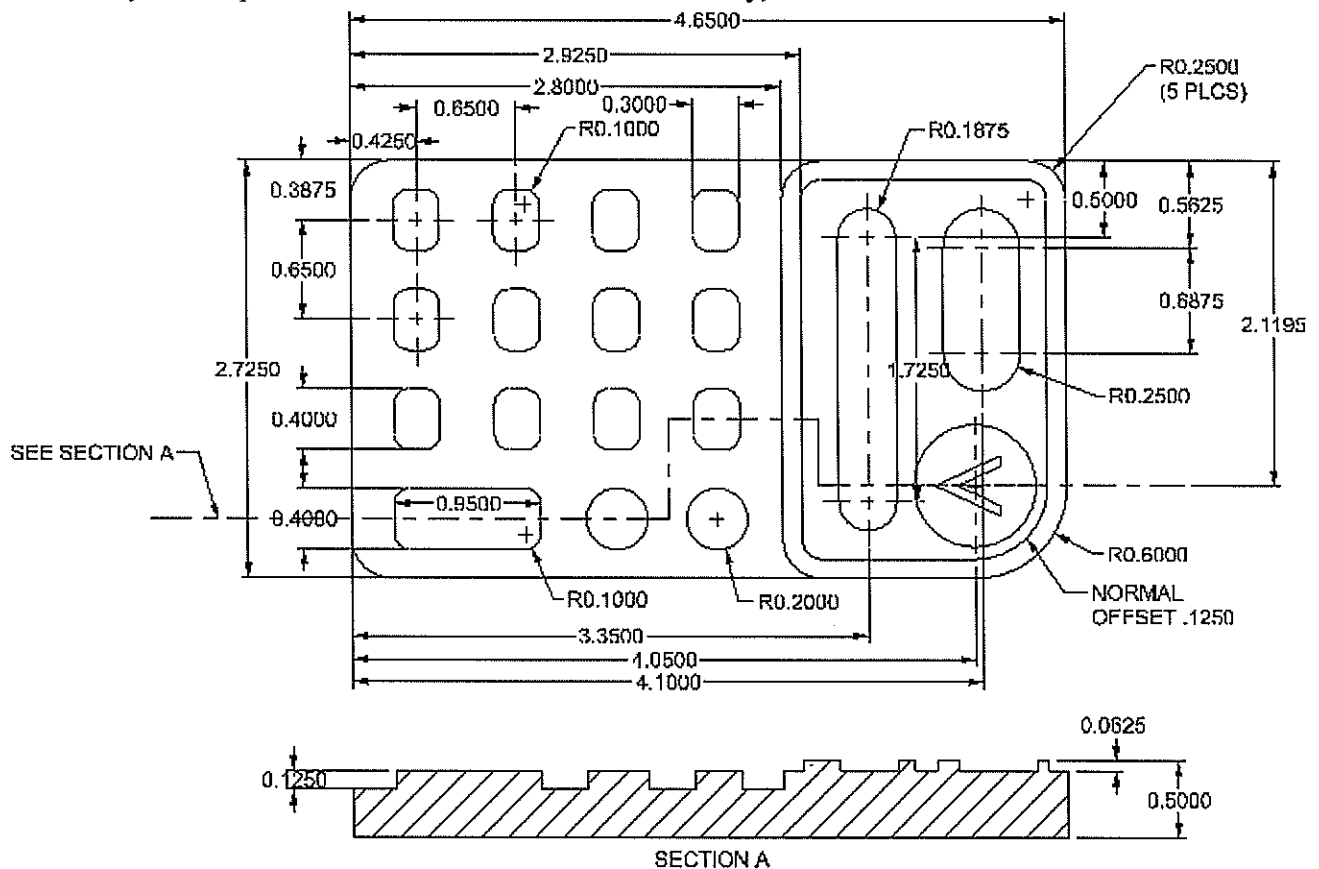

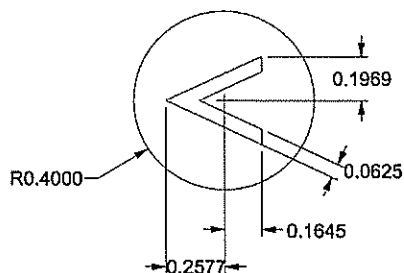

Learning Outcome

In this project the student will learn how to read a technical drawing. The student will have to accurately read a section view drawing to be able to determine cutting depths for the part.

The Following Must be Turned in with the Calculator Project

Turn in project in the following order

- Project cover page
- Page layout of calculator.(see figure 1a)
 - 1 detail of top view (show 2D layout of calculator and section view)
 - 1 detail of a rendered perspective
- Machined calculator

Complete the Following for the Calculator Project

1. Using Rhino, create a 3D model of the calculator above, figure 1b.

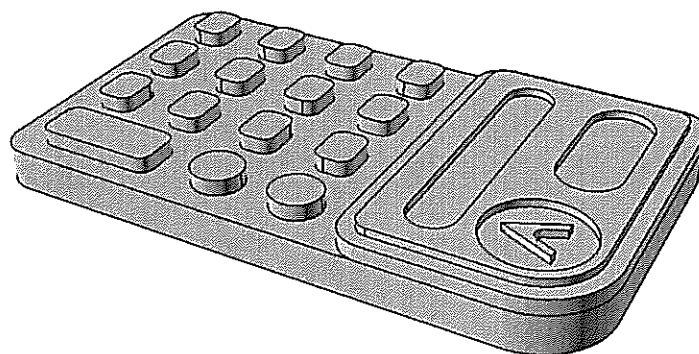

Figure 1b

2. Using Rhino, create a section view of the calculator

Section view should:

- Be different than the one above
- Be lined up under a top view
- Include a section line
- Include cross-section lines

Directions for Machining the Calculator

1. Draw the calculator in the center of a 3" x 5" rectangle, figure 1a

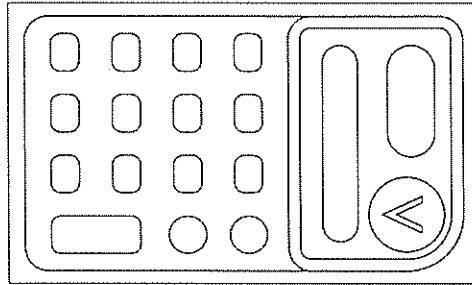

Figure 1a

2. FILLET the inside corner of the "V" with a radius of .0625, figure 1b

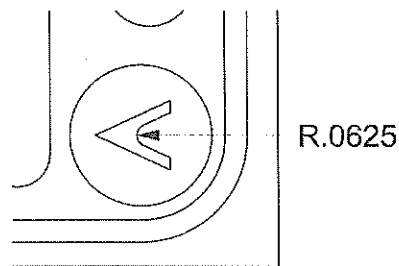

Figure 1b

3. Save the drawing
4. Save the drawing a second time as a dxf file (dxf files are commonly used with CAM software)
5. Use your CAM software to machine the calculator
5. Import your dxf file into your CAM program (these steps will not be the same for all CAD/CAM software)
6. Select the curves shown in figure 1c

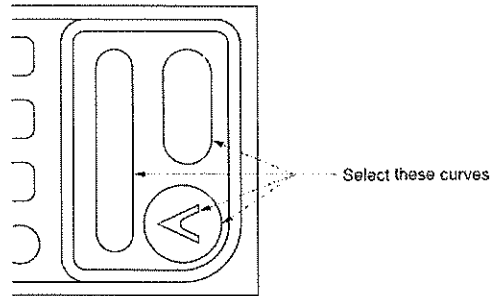

Figure 1c

7. Create a 1/16" deep POCKET TOOLPATH using a 1/8" end mill and the curves selected above as boundaries, figure 1d

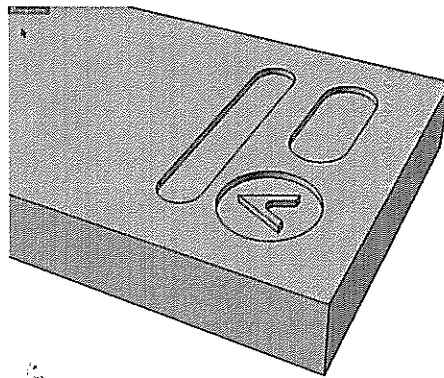

Figure 1d

8. Select the curve shown in figure 1e

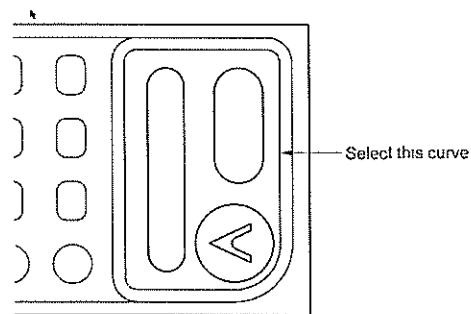

Figure 1e

9. Using a 1/8" end mill, create a 1/16" deep PROFILE TOOLPATH on the outside of the curve selected above, figure 1f

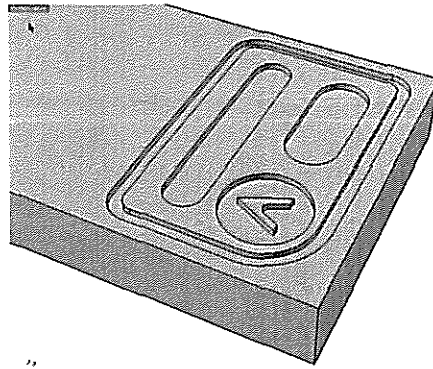

Figure 1f

10. Starting in the bottom right hand corner of the material, draw a rectangle that is 2.25" x 3" (this rectangle will be used as a boundary for the next POCKET TOOLPATH), figure 1g

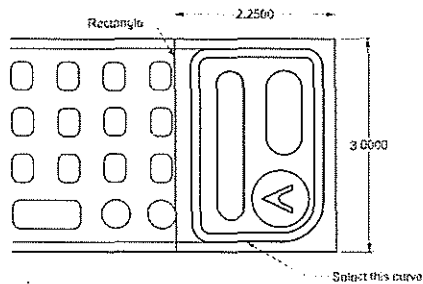

Figure 1g

11. Using a 1/8" end mill create a .1875" deep POCKET TOOLPATH using the rectangle and the curve selected above, (in the corners there will be some material left but when the part is cut out at the end they will be removed), figure 1h

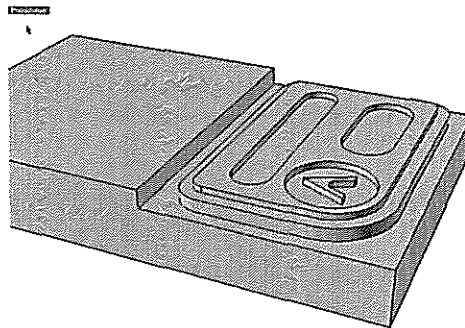

figure 1h

12. Starting in the bottom left hand corner of the material, draw a rectangle that is 2.975" x 3, figure 1i

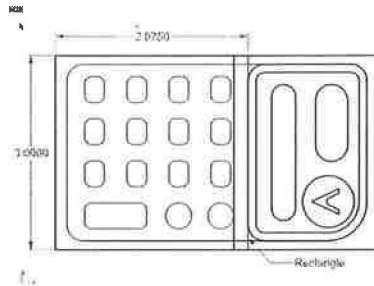

Figure 1i

13. Using a 1/8" end mill create a .0625" deep POCKET TOOLPATH using the rectangle you just created as a boundary, (in the corners there will be some material left but when the part is cut out at the end they will be removed), figure 1j

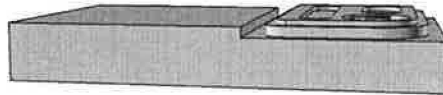

Figure 1j

14. Using a 1/8" end mill create a .125 deep POCKET TOOLPATH using the same rectangle you just created and all the calculator's buttons as boundaries, figure 1k

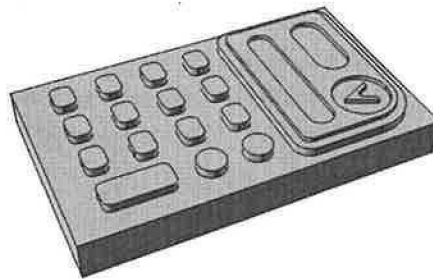

Figure 1k

15. Using a 1/4" end mill create a 1/2" deep PROFILE TOOLPATH on the outside of the entire calculator, figure 1l

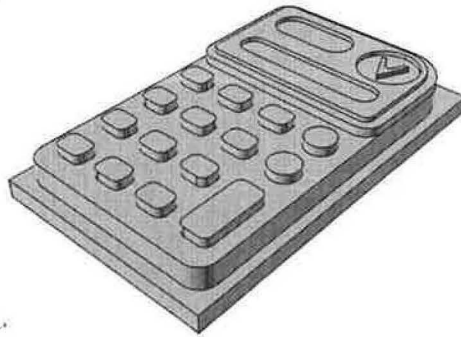

Figure 11

16. To cut the calculator completely out you must clamp the calculator up-side down and machine the back side, figure 1m



Figure 1m

17. Your toolpaths for the calculator are now complete. Using a post processor, save the toolpaths in the order of which they should be run.

Creating a Gasket Using the Milling Machine

Student Learning Targets

I can create a gasket given a set of parameters

- I will do this by using Rhino (CAD)
- I will do this by using PartWorks (CAM)
- I will demonstrate this by creating a gasket that meets the given parameters
- This means I can accurately read a technical drawing
- This means I can accurately generate toolpaths
- This means I can accurately and safely operate a CNC milling machine

Design Parameters

- Must cut the gasket provided using the ShopBot
- Must fit on a 4" x 4" piece of 3/4" thick material
- Select cutters from SB Starter Set in PartWorks
- Must use 1/8" step downs
- Must use Rhino to create 2D drawing (CAD)
- Must use PartWorks to create toolpaths (CAM)
- If your completed gasket does not fit the answer key, then REDO

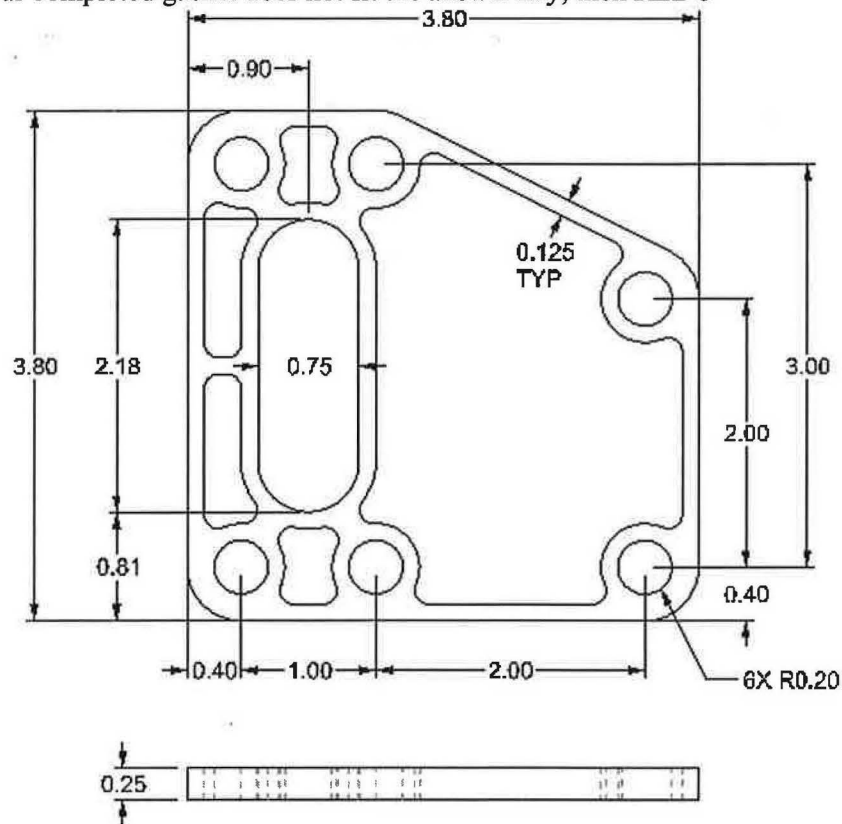

ALL ROUNDS R0.40
ALL FILLETS R0.10

Learning Outcome

In this project the students will learn how to read a multi-view drawing to determine how to machine the part.

The Following Must be Turned in with the Gasket Project

Turn in project in the following order

- Project cover page
- Completed math problems below
- Page layout of gasket (4-view, see figure 1a) (show hidden lines)
 - 1 detail of top view
 - 1 detail of a front view
 - 1 detail of right view
 - 1 detail of isometric view
- Machined gasket

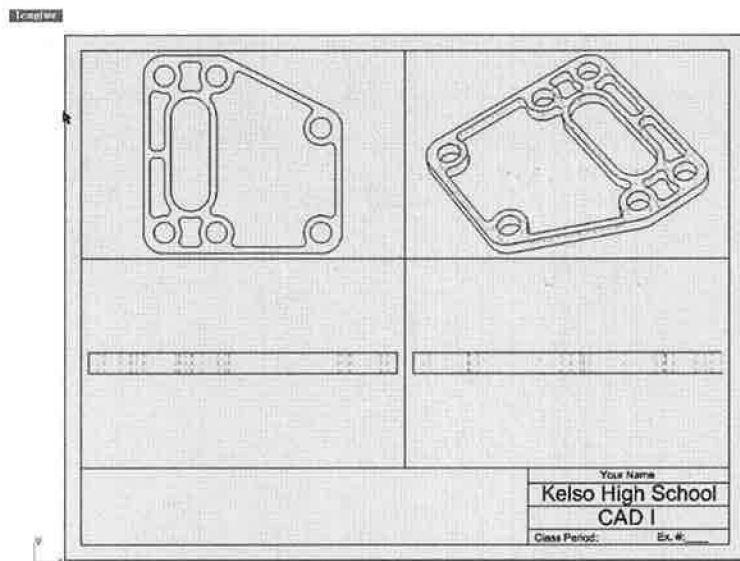

Figure 1a

Complete the Following Math Questions for the Gasket Project
YOU MUST SHOW ALL MATH TO RECEIVE CREDIT!!!

1. If you machined a gasket that had a volume of .9244 cubic inches out of a piece of machinable wax that had a volume of 4 cubic inches, what would the percentage of waste be for the wax? (nearest 100th of a percent)

2. If the machinable wax block cost \$1.97, how much money is wasted with every gasket that is cut out? (nearest \$.01)

3. If you melted down the wax shavings to make more machinable blocks, how many gaskets could you cut out of a 2" x 8" x 16" block of machinable wax and the gasket had the same volume as the one above? (nearest whole number)

4. How many gaskets would you have to cut to be able to fill a 1 gallon garbage can with shavings (pretending we did not have to account for air space)

Directions for Machining the Gasket

1. Draw the gasket in the center of a 4" x 4" rectangle as shown on handout, figure 1a

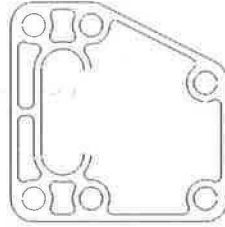

Figure 1a

2. Save the drawing
3. Save the drawing a second time as a dxf file (dxf files are commonly used with CAM software)
4. Use your CAM software to machine the gasket
5. Import your dxf file into your CAM program (these steps will not be the same for all CAD/CAM software)
6. Select the curves shown in figure 1b

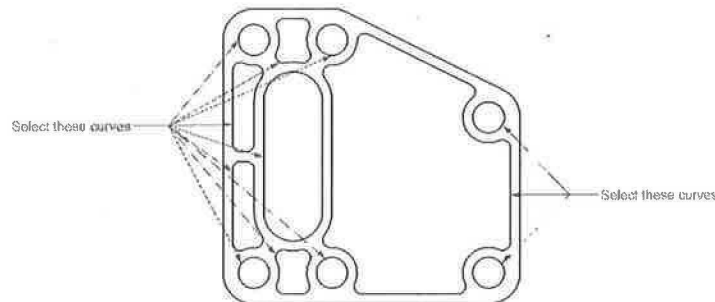

Figure 1b

7. Create a 1/4" deep POCKET TOOLPATH using a 1/8" end mill and the selected curves above as boundaries, figure 1c

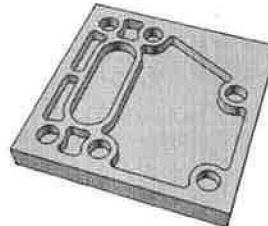

Figure 1c

8. Using a 1/2" end mill, create a 1/4" deep PROFILE TOOLPATH on the outside of the entire gasket, figure 1d

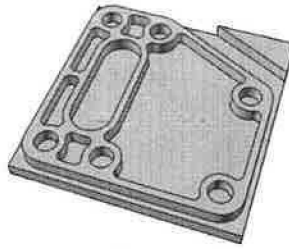

Figure 1d

9. Using a 1/2" end mill machine down the corner that still has material left over (this is machined down to allow for the piece to be easily clamped in a vice or jig for the next step), figure 1e

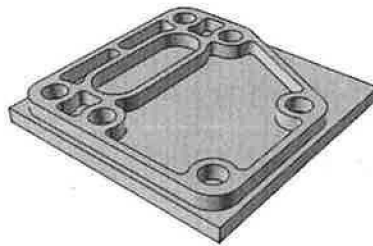

Figure 1e.

10. To cut the gasket completely out you must clamp the gasket up-side down and use a POCKET TOOLPATH to machine the entire back side down to the desired thickness, figure 1f



Figure 1f

11. Your toolpaths for the gasket are now complete. Using a post processor, save the toolpaths in the order of which they should be run.

Creating a Cam Using the Milling Machine

Student Learning Targets

I can create a cam given a set of parameters

- I will do this by using Rhino (CAD)
- I will do this by using PartWorks (CAM)
- I will demonstrate this by creating a cam that meets the given parameters
- This means I can accurately read a technical drawing
- This means I can accurately generate toolpaths
- This means I can accurately and safely operate a CNC milling machine

Design Parameters

- Must cut the cam using the ShopBot
- Must fit on a 3" x 4" piece of $\frac{3}{4}$ " thick material
- Must use $\frac{1}{8}$ " step downs
- Must use Rhino to create 2D drawing (CAD)
- Must use PartWorks to create toolpaths (CAM)
- If your completed part does not fit the answer key, then REDO

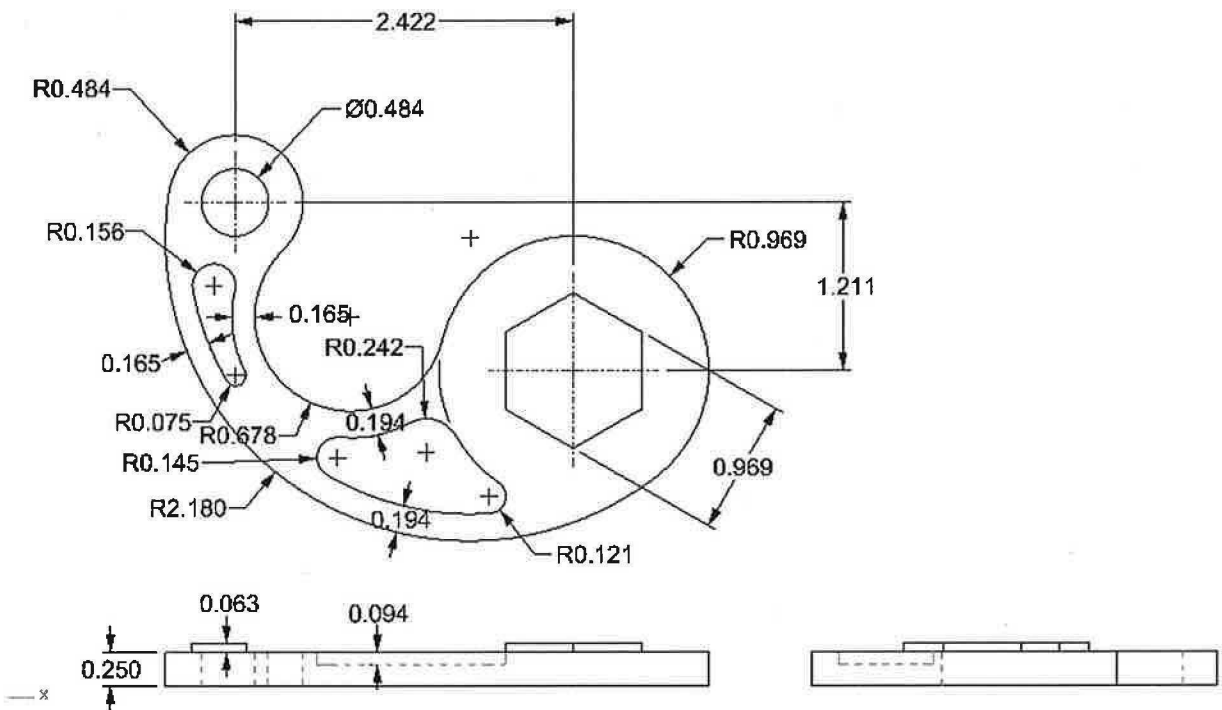

Learning Outcome

In this project the student will learn how to read a technical drawing. The student will have to accurately read a 3-view drawing to be able to determine the cutting depths for the part. They will also be introduced to the important use of jigs and fixtures.

The Following Must be Turned in with the Cam Project

Turn in project in the following order

- Project cover page
- Page layout of cam jig
 - 1 detail of rendered perspective view
- Page layout of cam jig (4-view, show hidden lines & dimensions)
 - 1 detail of top view
 - 1 detail of a front view
 - 1 detail of right view
 - 1 detail of isometric view
- Jig
- Machined cam to final thickness

Complete the Following Assignments for the Cam Project

1. Your task is to plan, design, and construct a jig or fixture that can be used to hold down the cam part to allow one to cut the cam to its final thickness.
2. Create a 3D model of your jig/fixture
3. Machine the back side of the cam part to its final thickness

Directions for Machining the Cam

1. Draw the cam in the center of a 3" x 4" rectangle as shown on handout, figure 1a

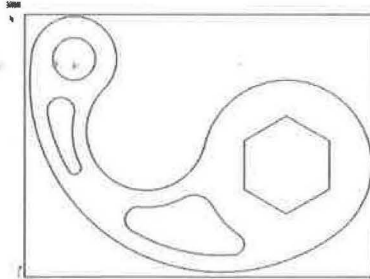

Figure 1a

2. Save the drawing
3. Save the drawing a second time as a dxf file (dxf files are commonly used with CAM software)
4. Use your CAM software to machine the cam
5. Import your dxf file into your CAM program (these steps will not be the same for all CAD/CAM software)
6. OFFSET the rectangle outward $\frac{1}{4}$ " (the rectangle will be used for a boundary on the next step), figure 1b

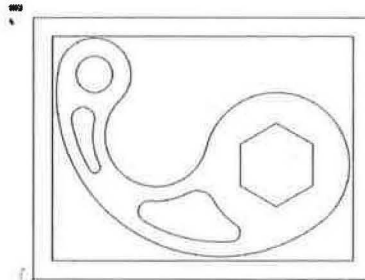

Figure 1b

7. Select the curves shown in figure 1c

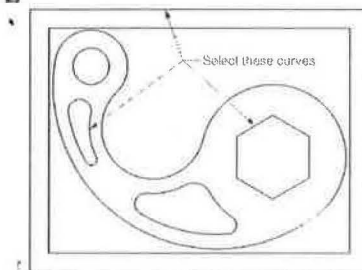

Figure 1c

7. Create a .063" deep POCKET TOOLPATH using a 1/4" end mill and the selected curves above as boundaries, figure 1d

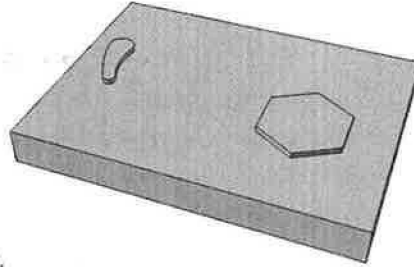

Figure 1d

8. Select the curve shown in figure 1e

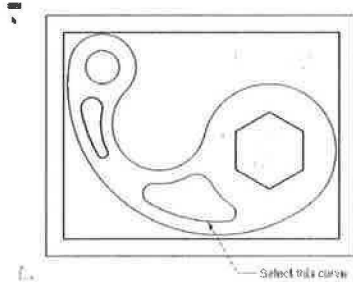

Figure 1e

9. Create a .094" deep POCKET TOOLPATH using a 1/4" end mill and the selected curve above as the boundary, figure 1f

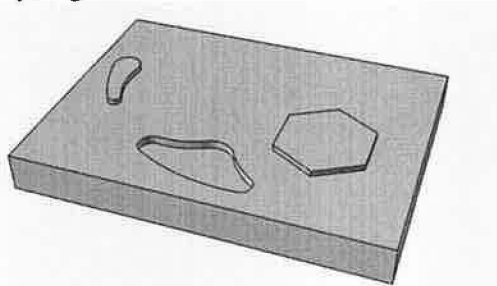

Figure 1f

10. Select the circle on the cam drawing

11. Create a .25" deep POCKET TOOLPATH using a 1/4" end mill and the selected circle as the boundary, figure 1g

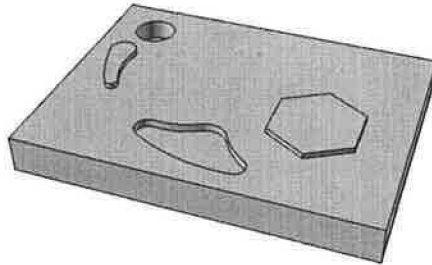

Figure 1g

12. Select the outside curve of the cam and the outer rectangle

13. Create a .25" deep POCKET TOOLPATH using a 1/4" end mill and the selected curves in step 12 as the boundaries, figure 1h

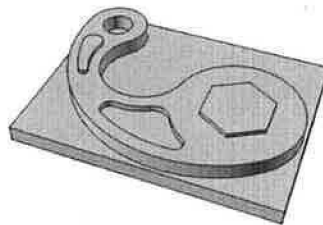

Figure 1h

14. To cut the cam completely out you must create a jig or fixture to hold the cam so you can use a POCKET TOOLPATH to machine the entire back side down to the desired thickness (building the jig or fixture is a project in itself), figure 1i



Figure 1i

15. Your toolpaths for the cam are now complete. Using a post processor, save the toolpaths in the order of which they should be run.

Creating a Frisbee Using the Milling Machine

Student Learning Targets

I can create a frisbee given a set of parameters

- I will do this by using Rhino (CAD)
- I will do this by using PartWorks (CAM)
- I will demonstrate this by creating a frisbee that meets the given parameters
- This means I can accurately read a technical drawing
- This means I can accurately generate toolpaths
- This means I can accurately and safely operate a CNC milling machine

Design Parameters

- Must cut the frisbee using the ShopBot
- Must fit on an 3" x 3" piece of 3/4" thick material
- Must use 1/8" step downs
- Must use Rhino to create 2D drawing (CAD)
- Must use PartWorks to create toolpaths (CAM)
- If your completed part does not fit the answer key, then REDO

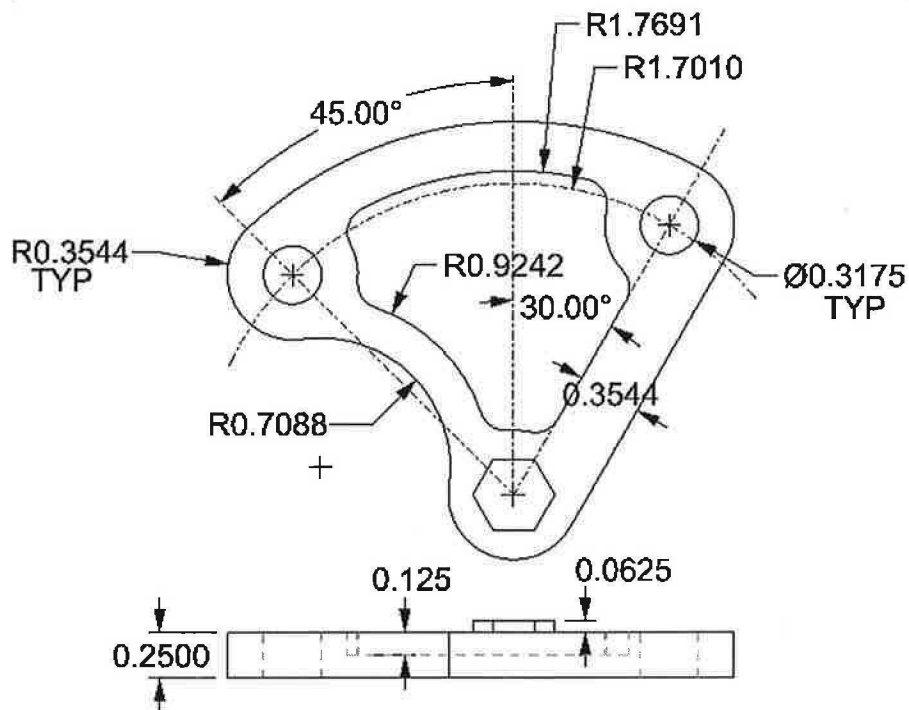

Learning Outcome

In this project the student will learn how to read a technical drawing. The student will have to accurately read a multi-view drawing to be able to determine the cutting depths for the part. They will also be introduced to the important use of jigs and fixtures.

The Following Must be Turned in with the Frisbee Project

Turn in project in the following order

- Project cover page
- Page layout of frisbee jig
 - 1 detail of rendered perspective view
- Page layout of frisbee jig (4-view, show hidden lines & dimensions)
 - 1 detail of top view
 - 1 detail of a front view
 - 1 detail of right view
 - 1 detail of isometric view
- Jig
- Machined frisbee to final thickness

Complete the Following Assignments for the Frisbee Project

1. Your task is to plan, design, and construct a jig or fixture that can be used to hold down the frisbee part to allow one to cut the frisbee to its final thickness.

2. Create a 4-view drawing of your jig/fixture

Your drawing will:

- Be completely 2D
- Include top, front, right, perspective views
- Display hidden lines
- Display all needed dimensions

3. Machine the back side of the frisbee part to its final thickness

Directions for Machining the Frisbee

1. Draw the frisbee in the center of a 3" x 3" rectangle as shown on handout, figure 1a

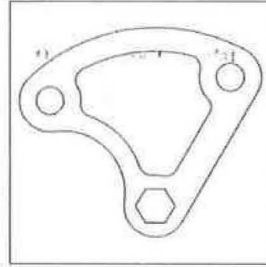

Figure 1a

2. Save the drawing
3. Save the drawing a second time as a dxf file (dxf files are commonly used with CAM software)
4. Use your CAM software to machine the frisbee
5. Import your dxf file into your CAM program (these steps will not be the same for all CAD/CAM software)
6. OFFSET the rectangle outward .15" (the rectangle will be used for a boundary on the next step), figure 1b



Figure 1b

7. Select the outer rectangle and the hexagon
8. Create a .0625" deep POCKET TOOLPATH using a 1/4" end mill and the selected curves above as boundaries, figure 1c

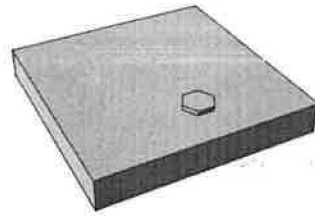

Figure 1c

9. Select the curve shown in figure 1d

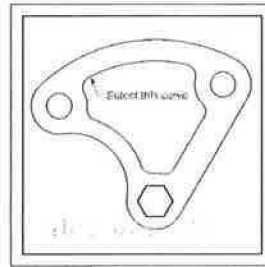

Figure 1d

10. Create a .125" deep POCKET TOOLPATH using a 1/4" end mill and the selected curve above as a boundary, figure 1e

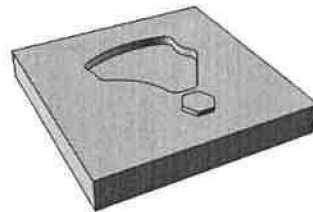

Figure 1e

11. Select the 2 circles

12. Create a .25" deep POCKET TOOLPATH using a 1/4" end mill and the selected circles as the boundaries, figure 1f

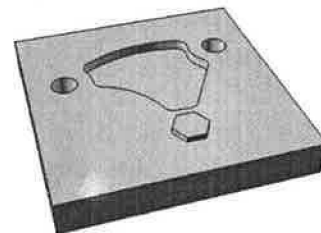

Figure 1f

13. Select the outside curve of the frisbee and the outer rectangle
14. Create a .25" deep POCKET TOOLPATH using a 1/4" end mill and the selected curves in step 13 as the boundaries, figure 1g

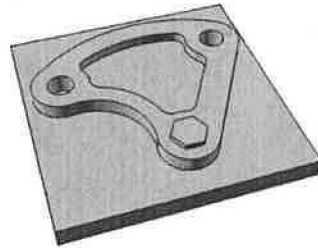

Figure 1g

15. To cut the frisbee completely out you must create a jig or fixture to hold the frisbee so you can use a POCKET TOOLPATH to machine the entire back side down to the desired thickness (building the jig or fixture is a project in itself), figure 1h



Figure 1h

16. Your toolpaths for the frisbee are now complete. Using a post processor, save the toolpaths in the order of which they should be run.

Cutting a Lego Using the Milling Machine

Student Learning Targets

I can create a Lego given a set of parameters

- I will do this by using Rhino (CAD)
- I will do this by using PartWorks (CAM)
- I will demonstrate this by creating a Lego that meets the given parameters
- This means I can accurately read a dial caliper
- This means I can accurately generate toolpaths
- This means I can accurately and safely operate a CNC milling machine

Design Parameters

- Using a dial caliper, measure a Lego to .001"
- Sketch a drawing with the measurements (top, front, right views)
- Use inches
- Use Rhino to draw a 2D drawing of top
- Build 3D model on a separate layer (do not model the bottom)
- Must machine Lego as shown below
- If your completed Lego does not fit the answer key then REDO

Perspective

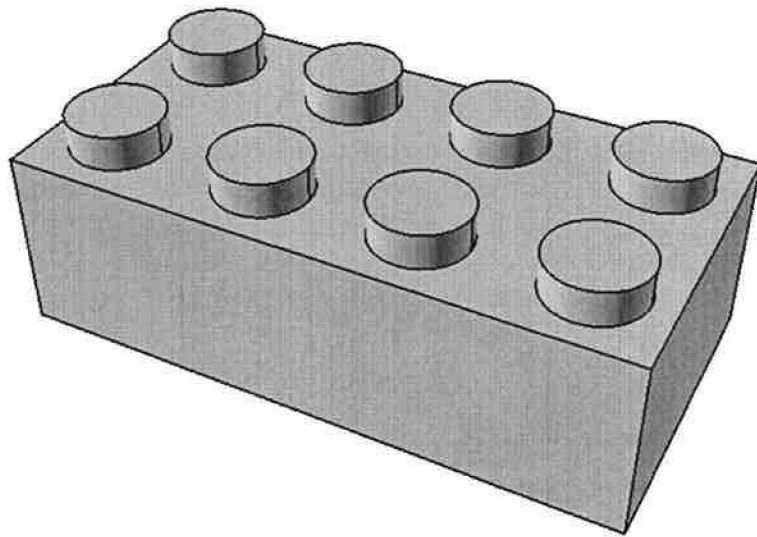

Learning Outcome

In this project the student will learn how to use a dial caliper for precision measuring. The student will understand the importance of precision measuring upon completion of the Lego project.

The Following Must be Turned in with the Lego Project

Turn in project in the following order

- Project cover page
- Completed math problems below
- Page layout of Lego (see figure 1a)
 - 1 detail of top view (show 2D layout, show dimensions of Lego)
 - 1 detail of a rendered perspective
- Machined Lego

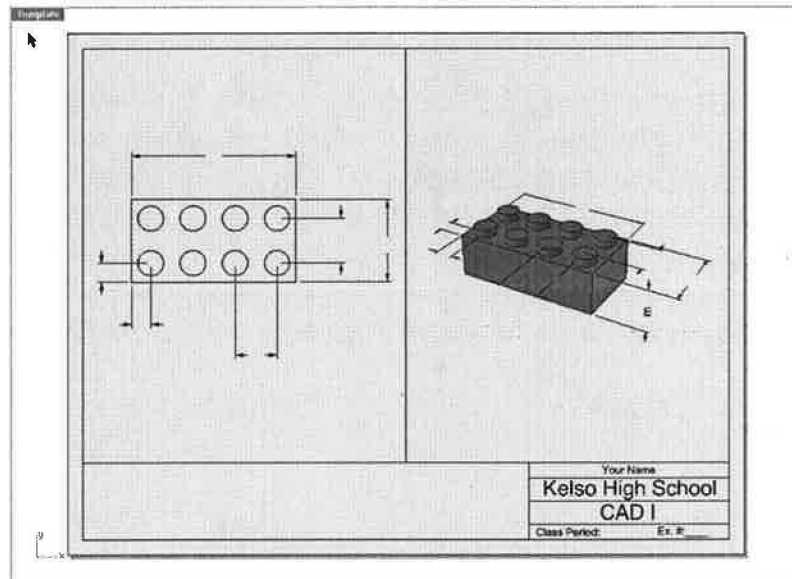
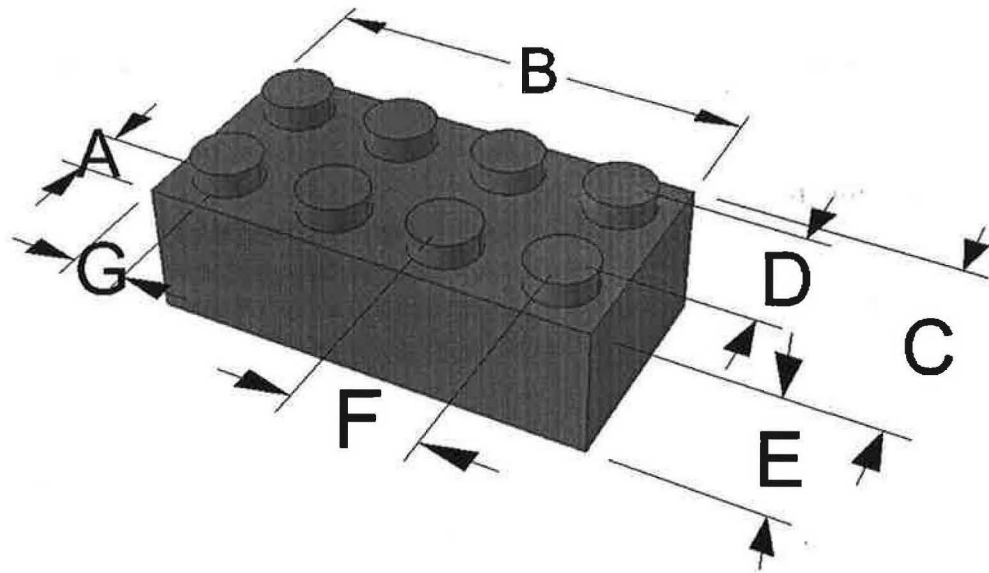

Figure 1a

Complete the Following Math Questions for the Lego Project YOU MUST SHOW ALL MATH TO RECEIVE CREDIT!!!

1. Fill in the dimensions below to resemble the Lego using millimeters (round to nearest .01 mm).



A= _____

B= _____

C= _____

D= _____

E= _____

F= _____

G= _____

2. Imagine you were going to pour a bunch of Legos as shown (solid block with extruded cylinders on the top). How many milliliters of plastic would you have to pour to create 1 Lego?

3. How many Legos could you fit in the shipping box used for the golf ball project?

Directions for Machining the Lego

1. Using a dial caliper, measure a Lego to .001"
2. Using the RECTANGLE command, draw the top rectangle of the Lego, figure 1a

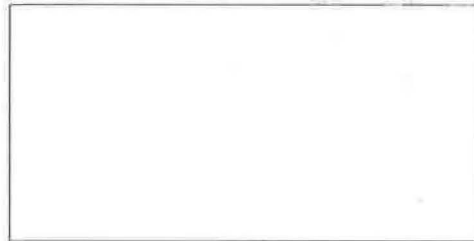

Figure 1a

3. EXPLODE the rectangle
4. Use OFFSET to layout the center of the Lego's circles, figure 1b

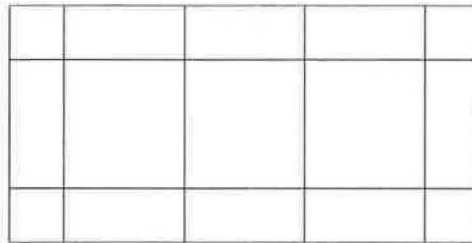

Figure 1b

5. Draw a CIRCLE according to the diameter you measured off the Lego, figure 1c

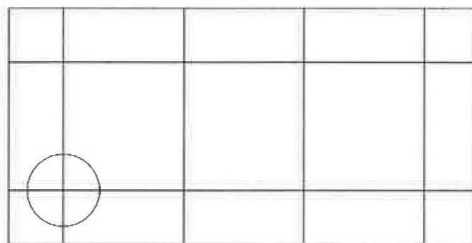

Figure 1c

6. COPY the circle to all the required locations, figure 1d.

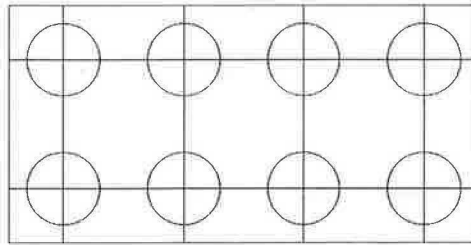

Figure 1d

7. HIDE the curves used for locating centers of circles, figure 1e

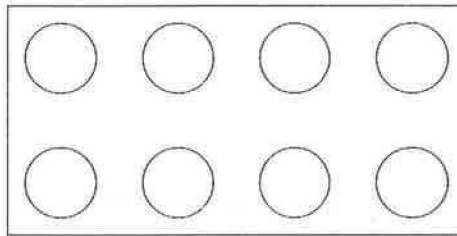

Figure 1e

8. Center the curves in a .75" x 1.5" rectangle, figure 1f

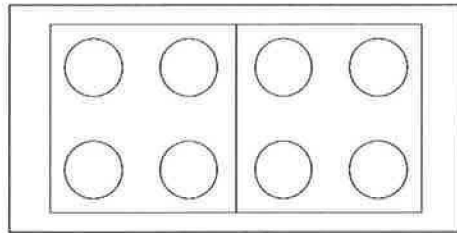

Figure 1f

9. Save the drawing
10. Save the drawing a second time as a dxf file (dxf files are commonly used with CAM software)
11. Use your CAM software to machine the Lego
12. Import your dxf file into your CAM program (these steps will not be the same for all CAD/CAM software)
13. OFFSET the outer rectangle outward .125"

14. Select the outer rectangle and the circles

15. Create a POCKET TOOLPATH using a 1/8" end mill and the selected curves as the boundaries (the depth is determined by the height of the cylinders you measure on top of the Lego), figure 1g

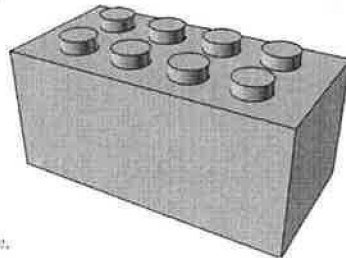

Figure 1g

16. Select both the inner and the outer rectangle

17. Create a POCKET TOOLPATH using a 1/8" end mill and the selected curves as the boundaries (the depth is determined by the height of the rectangular base of the Lego, the pocket toolpath is used instead of a profile to make sure the corners are machined down as well to make clamping the Lego upside down easy), figure 1h

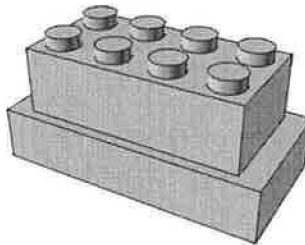

Figure 1h

18. To cut the Lego completely out you must clamp the Lego up-side down and use a POCKET TOOLPATH to machine the entire back side down to the desired thickness, figure 1i

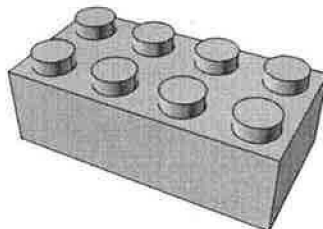

Figure 1i

19. Your toolpaths for the Lego are now complete. Using a post processor, save the toolpaths in the order of which they should be run.

Create an Adaptive Device for Folding Silverware in Napkins

Student Learning Targets

I can create an adaptive device given a set of parameters

- I will do this by using Rhino (CAD)
- I will do this by using PartWorks (CAM)
- I will demonstrate this by creating an adaptive device that meets the given parameters
- This means I can accurately generate toolpaths
- This means I can accurately and safely operate a CNC milling machine

Design Parameters

- Create an adaptive device for folding silverware in napkins
- Device is to be used by a person who is legally blind
- Material can only be removed from the block of wood, not added
- Use a 12" X 12" piece of 1 ½" thick particle board to construct the device
- Include 1 fork, 1 spoon, 1 knife (see teacher for silverware)
- Include 1 8½"x 8½" napkin

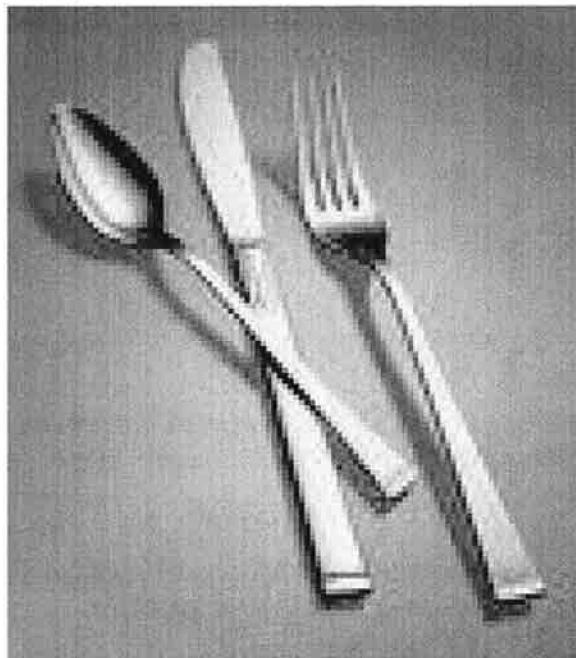

Learning Outcome

In this project the student will learn about the importance of design. They will also learn how to use technical writing skills to describe their design by creating a descriptive tutorial.

Directions for Machining an Adaptive Device for Folding Silverware in Napkins

1. Measure the silverware that is to be used with the device
2. Draw your device idea and the location of the napkin, fork, knife, spoon, etc., figure 1a

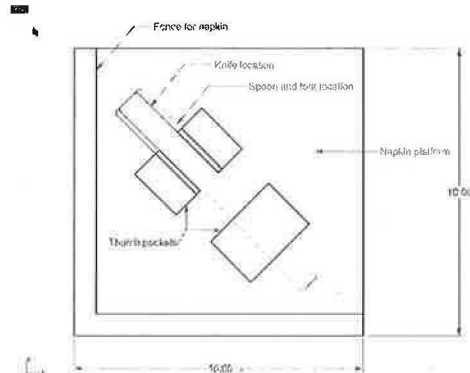

Figure 1a

3. Save the drawing
4. Save the drawing a second time as a dxf file (dxf files are commonly used with CAM software)
5. Use your CAM software to machine the adaptive device
6. Import your dxf file into your CAM program (these steps will not be the same for all CAD/CAM software)
7. Draw a 9.5" x 9.5" RECTANGLE as shown in figure 1b

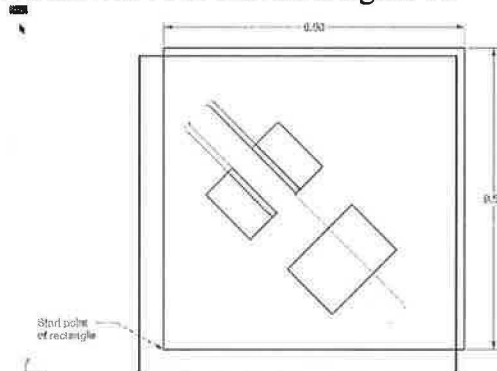

Figure 1b

8. Create a 1/4" deep POCKET TOOLPATH using a 1/2" end mill and the rectangle created above as the boundary (you will have to chisel out the inside corner), figure 1c

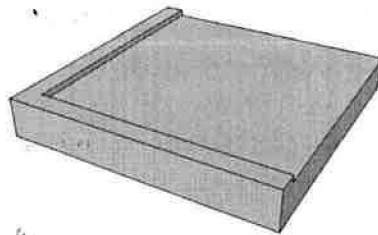

Figure 1c

9. Select the curve shown in figure 1d

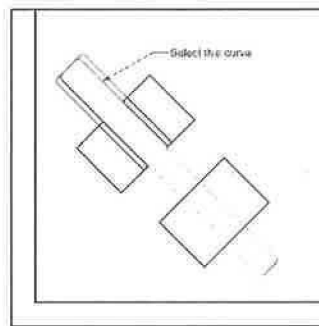

Figure 1d

10. Starting at a depth of .25, create a .75" deep POCKET TOOLPATH using a $\frac{1}{4}$ " end mill and the curve selected above as the boundary (for beginners it may be easier to use a start depth of 0 and creating a 1" deep POCKET TOOLPATH), figure 1e

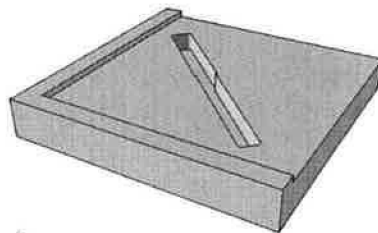

Figure 1e

11. Select the curve shown in figure 1f

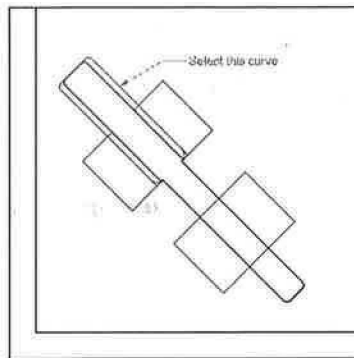

Figure 1f

12. Starting at a depth of .25, create a .5" deep POCKET TOOLPATH using a $\frac{1}{4}$ " end mill and the curve selected above as the boundary (for beginners it may be easier to use a start depth of 0 and creating a .75" deep POCKET TOOLPATH), figure 1g

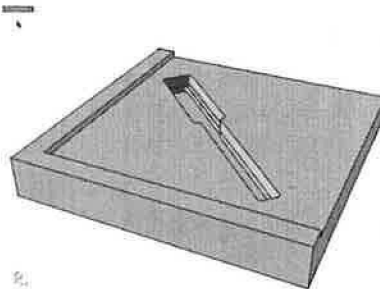

Figure 1g

13. Select the curves shown in figure 1h

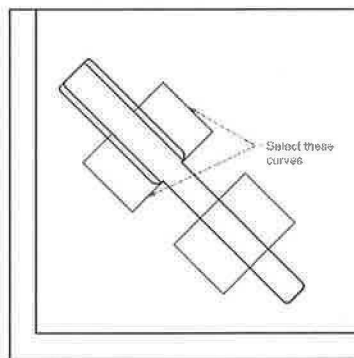

Figure 1h

14. Starting at a depth of .25, create a .5" deep POCKET TOOLPATH using a $\frac{1}{4}$ " end mill and the curves selected above as the boundaries (for beginners it may be easier to use a start depth of 0 and creating a .75" deep POCKET TOOLPATH), figure 1i

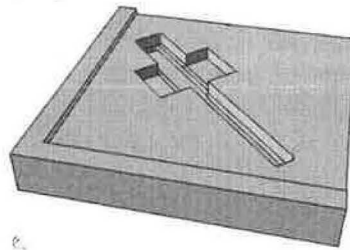

Figure 1i

15. Select the curves shown in figure 1j

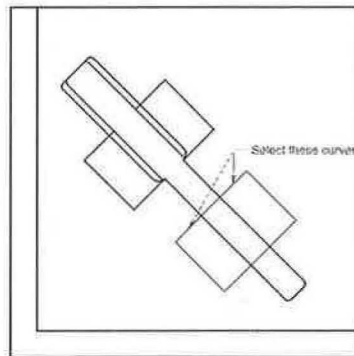

Figure 1j

16. Starting at a depth of .25, create a 1.125" deep POCKET TOOLPATH using a $\frac{1}{4}$ " end mill and the curves selected above as the boundaries (for beginners it may be easier to use a start depth of 0 and creating a 1.375" deep POCKET TOOLPATH), figure 1k

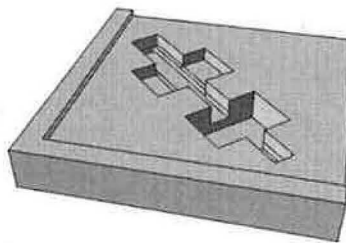

Figure 1k

17. Your toolpaths for the adaptive device are now complete. Using a post processor, save the toolpaths in the order of which they should be run.

Create a Small Box Using the Milling Machine

Student Learning Targets

I can create a small box given a set of parameters

- I will do this by using Rhino (CAD)
- I will do this by using PartWorks (CAM)
- I will demonstrate this by creating a small box that meets the given parameters
- This means I can accurately generate toolpaths
- This means I can accurately and safely operate a CNC milling machine

Design Parameters

- Must create a box out of a block of wood (see teacher for block)
- Must use the ShopBot for all cuts
- Box must contain a top that attaches in some way other than hinges
- The use of glue or fasteners is prohibited

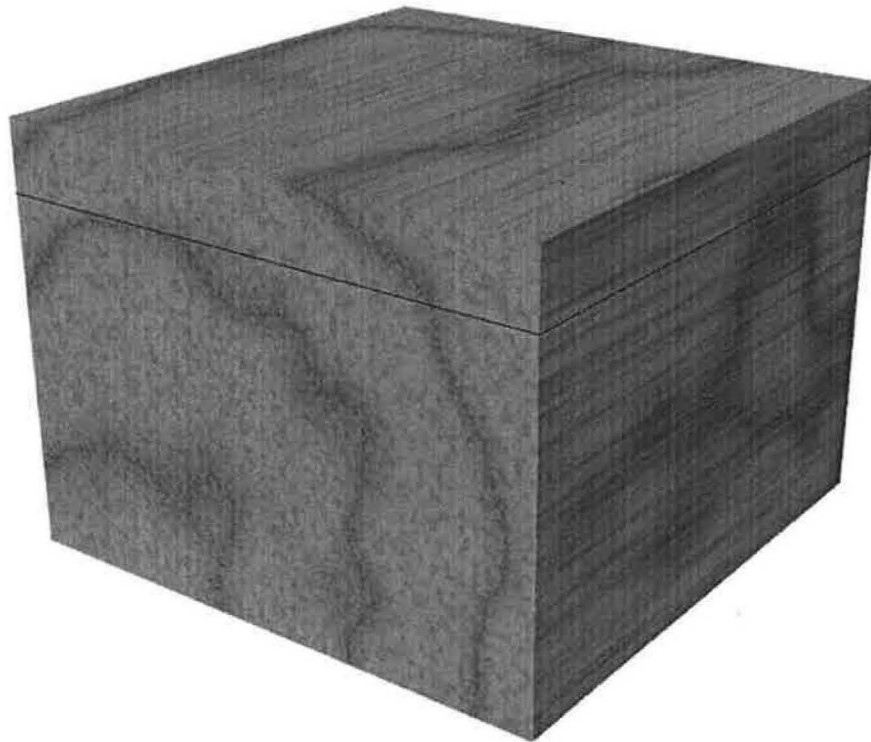

Learning Outcome

In this project the student will learn the importance of designing a product for manufacturability. They will also learn how to use technical writing skills to describe their design by creating a descriptive tutorial.

The Following Must be Turned in with the Small Box Project

Turn in project in the following order

- Project cover page
- Completed tutorial
- Page layout of small box (4-view, show all hidden lines and dimensions)
 - 1 detail of top view
 - 1 detail of a front view
 - 1 detail of right view
 - 1 detail of isometric view
- Machined small box

Complete the Following Assignments for the Small Box Project

1. Your task for the box assignment is to write a tutorial that shows the sequence of steps you used to create a small box out of a solid block of material.

Your tutorial will:

- Include pictures only
- Show the ShopBot table for a reference
- Show the cutter used for a reference
- Show the toolpaths used
- Show a sequence of steps
- Be graded based on if one can machine your box from the instructions provided

2. Create a 4-view drawing of your small box

Your drawing will:

- Be completely 2D
- Include top, front, right, isometric views
- Display hidden lines
- Display all needed dimensions

Directions for Creating a Small Box

1. Measure the rough block of material given by teacher
2. Sketch a box (top, front, right views) that you will make out of the block of material (keep in mind the block of material must be squared up-see the square cube assignment), figure 1a

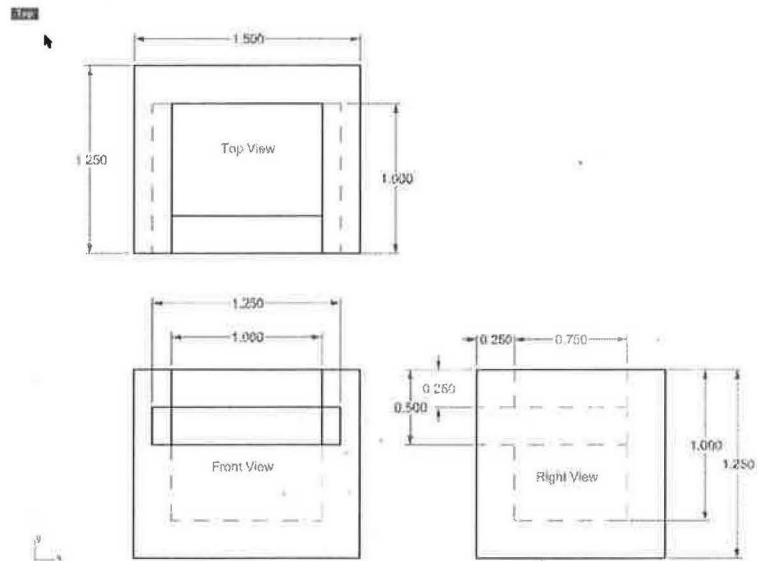

Figure 1a

3. For this example I will use a “squared-up” block that is $1\frac{1}{2}$ ” wide x 2” long x $1\frac{1}{4}$ ” tall and a $\frac{1}{4}$ ” end mill cutter, figure 1b

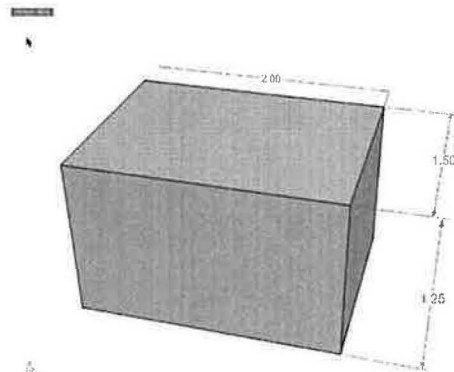

Figure 1b

4. Stand the block up on its left side and cut the top down to size (the top in this example is $\frac{1}{2}$ ” thick x $1\frac{1}{4}$ ” wide x 1” long), figure 1c

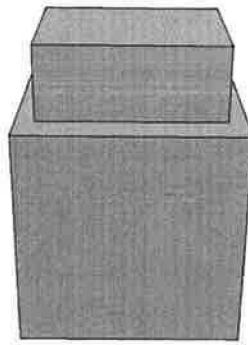

Figure 1c

5. Cut $1/8$ " wide x $1/4$ " deep rabbets down 2 edges of top, figure 1d

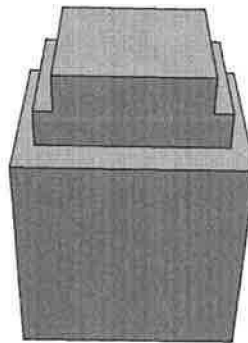

Figure 1d

6. Rotate the block so that it lays flat and cut the top off the right side, figure 1e

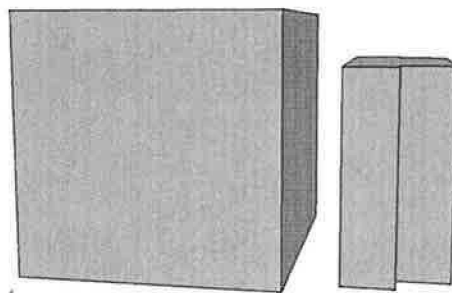

Figure 1e

7. Cut out the inside of the box, leaving $1/4$ " of material on the bottom and 4 sides, figure 1f

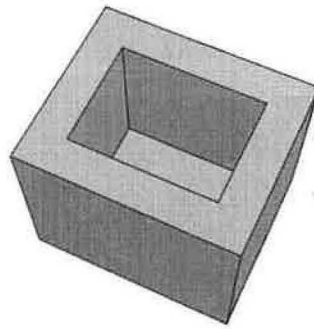

Figure 1f

8. Rotate the box so it rests on the left(back) side

9. Cut material away from the front and cut a 1/8" deep x 1/4" wide dado down each side of the box, figure 1g

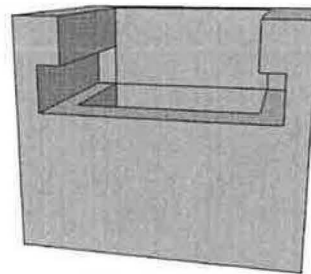

Figure 1g

10. After sanding or rounding some edges on the top, slide the top into place, (you will have to slightly round some edges on the top to fit into the dados in the sides as the cutter will leave rounded corners when the pockets are cut), figure 1h

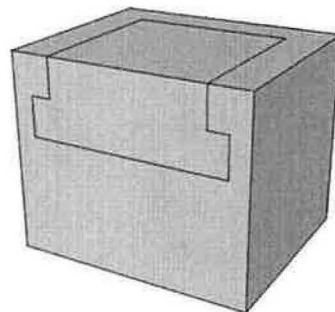

Figure 1h

Create a Square Cube Using the Milling Machine

Student Learning Targets

I can create a square cube given a set of parameters

- I will do this by using Rhino (CAD)
- I will do this by using PartWorks (CAM)
- I will demonstrate this by creating a square cube that meets the given parameters
- This means I can accurately generate toolpaths
- This means I can accurately and safely operate a CNC milling machine

Design Parameters

- Must complete the pre-write on the next page prior to starting project
- Must create a $\frac{3}{4}$ "x $\frac{3}{4}$ " x $\frac{3}{4}$ " square cube
- ALL sides must be $\frac{3}{4}$ "
- ALL sides must be square
- CAREFULLY check the maximum height of the Z-height on the ShopBot prior to planning your process
- The Z-height will impact the length of the cutter you use, height of part, height of clamps, height of jigs, fixtures, and much more

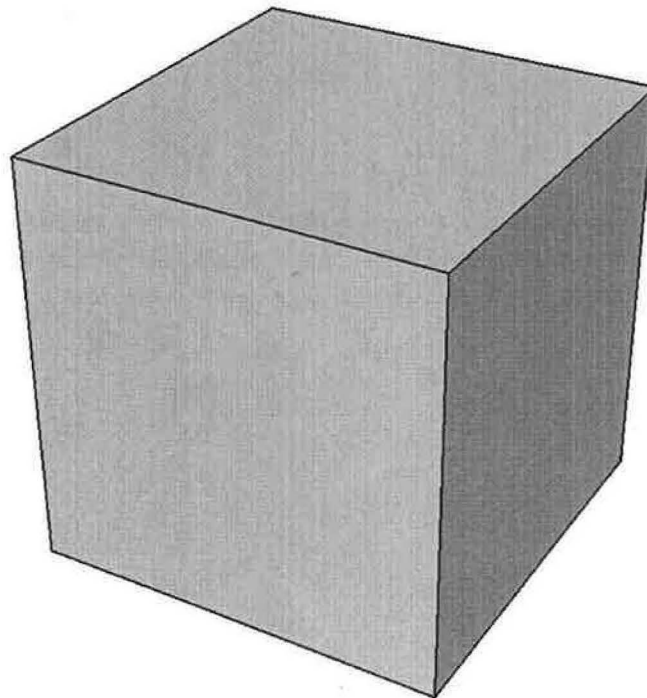

Learning Outcome

In this project the student will learn the importance and difficulty of creating a square cube. They will need to be able to create a square cube in order to have success in machining the captive cube project.

The Following Must be Turned in with the Square Cube Project

Turn in project in the following order

- Project cover page
- Completed math problems below (there is a write-up prior to machining block)
- Machined square cube

Complete the Following Questions for the Square Cube Project YOU MUST SHOW ALL MATH TO RECEIVE CREDIT!!!

Pre-write

1. In the space below, sketch the machining sequence you plan to use for this project (use both words and pictures)

2. Estimate how many toolpaths you will need to complete the project.

3. Estimate how long the part will take to machine (make comparisons to other parts you have machined)

Post-write

1. In the space below, sketch the machining sequence you ended up using for this project (use both words and pictures)

Directions for the Square Cube Assignment

- Encourage students to do this on their own as they will try every which way you can think of to create a square cube and they will struggle with it
 - Students will often create a parallelogram instead of a square cube
 - Create a jig that the square cubes must fit into to check for accuracy
1. Draw a RECTANGLE that is $\frac{3}{4}$ " x $\frac{3}{4}$ " and another RECTANGLE that represents the outside of the original block of material
 2. Center the $\frac{3}{4}$ " x $\frac{3}{4}$ " rectangle in the original block
 3. OFFSET the rectangle that represents the original block outward so that it can be used as a boundary to machine the top of the block and around the outside of the cube (the rectangle is created to allow the cutter to cut the entire top surface of the block and not leave pieces in the corners, it must also be offset far enough to allow a cutter to fit between it and the desired cube), figure 1a

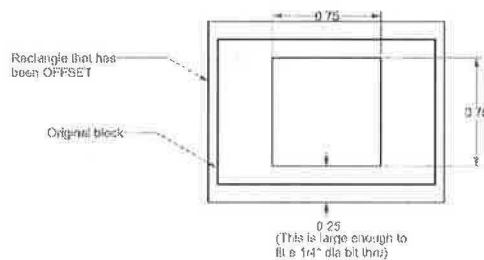

Figure 1a

4. Select the outside rectangle
5. Create a $\frac{1}{32}$ " deep POCKET TOOLPATH using a $\frac{1}{4}$ " end mill and the curve selected above as boundary (this toolpath cleans the top of the material)
6. Select the inside and outside rectangles, figure 1b

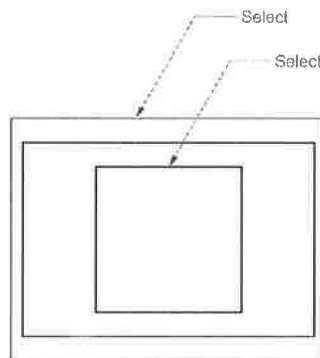

Figure 1b

7. Create a $\frac{3}{4}$ " deep POCKET TOOLPATH using a $\frac{1}{4}$ " end mill and the curves selected above as boundaries, figure 1c

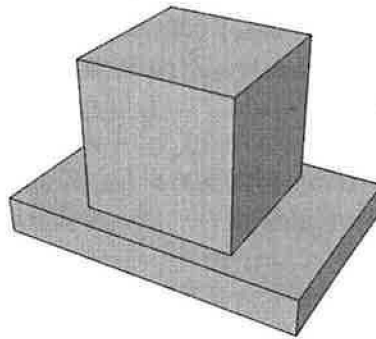

Figure 1c

8. To cut the cube completely out you must clamp the cube up-side down and machine the bottom side down to the desired height, figure 1d

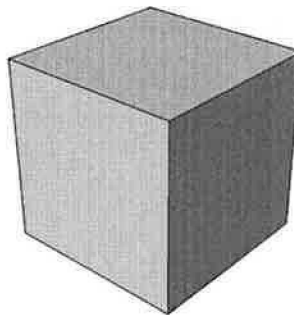

Figure 1d

9. Your toolpaths for the cube are now complete. Using a post processor, save the toolpaths in the order of which they should be run.

Create the Captive Cubes Using the Milling Machine

Student Learning Targets

I can create a captive cube given a set of parameters

- I will do this by using Rhino (CAD)
- I will do this by using PartWorks (CAM)
- I will demonstrate this by creating a captive cube that meets the given parameters
- This means I can accurately generate toolpaths
- This means I can accurately and safely operate a CNC milling machine

Design Parameters

- Must use a 2 inch cube
- Must include at least 3 cubes
- $\frac{1}{4}$ " diameter bit is the smallest bit you can use

Perspective

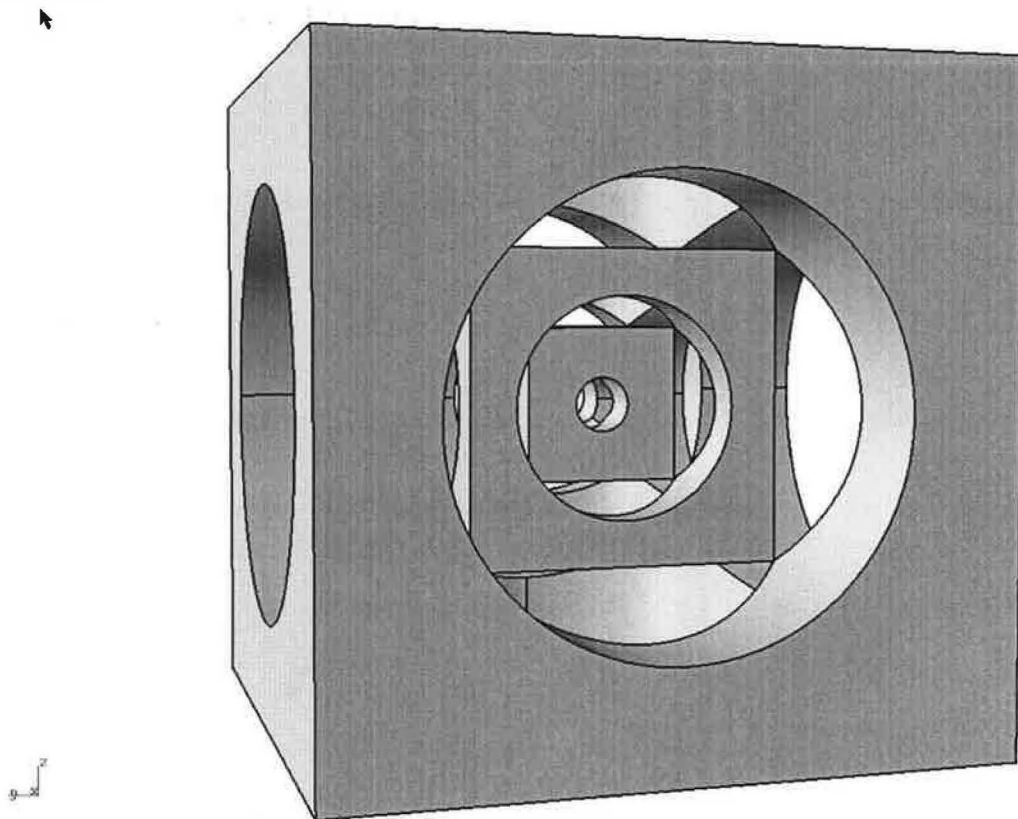

Learning Outcome

In this project the student will understand the importance of creating a square cube. They will also learn why they must accurately reference a part and be introduced to the use of jigs and fixtures.

Directions for the Captive Cube Assignment

1. Measure the rough block of material given by teacher
2. Machine the block so that it is a square cube (see square cube assignment)
3. Draw the outline of the cube using the RECTANGLE command, figure 1a

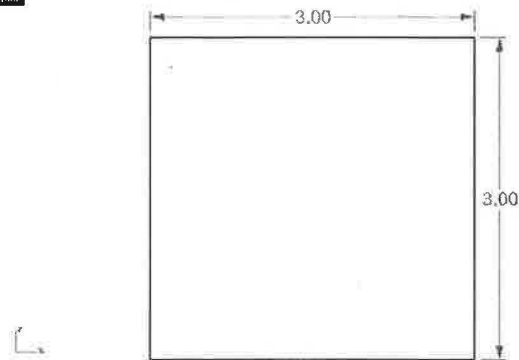

Figure 1a

4. Draw a large CIRCLE in the center of the rectangle, figure 1b

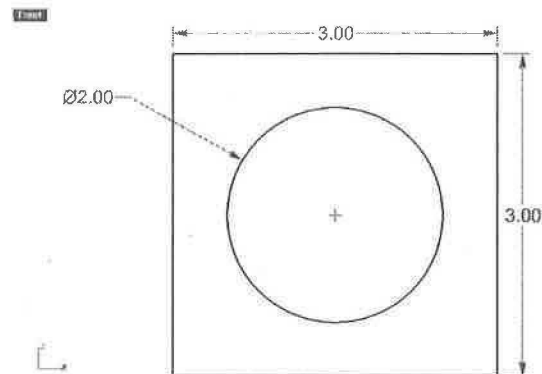

Figure 1b

5. Draw another RECTANGLE in the center of the current rectangle (this new rectangle should extend just slightly outside the circle to ensure the cube will not fall out of the circle when it is machined), figure 1c

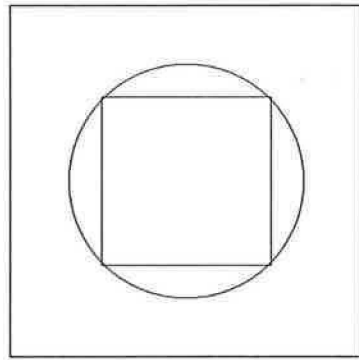

Figure 1c

6. Draw a smaller circle inside the rectangle you just drew, figure 1d

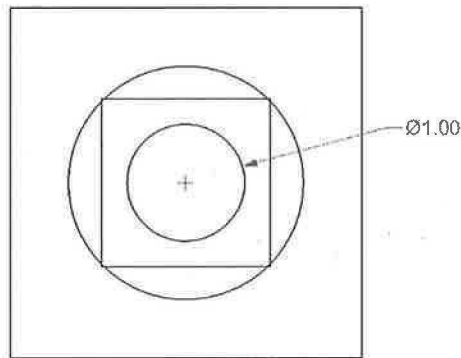

Figure 1d

7. Draw another small RECTANGLE in the center of the current rectangle (this new rectangle should extend just slightly outside the circle you just drew to ensure the cube will not fall out of the circle when it is machined), figure 1e

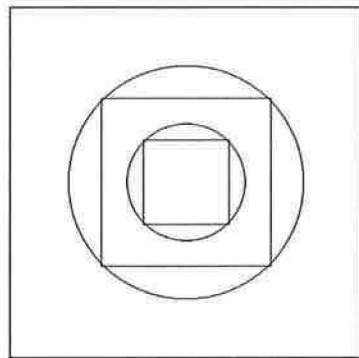

Figure 1e

8. Draw a smaller circle inside the rectangle you just drew, figure 1f

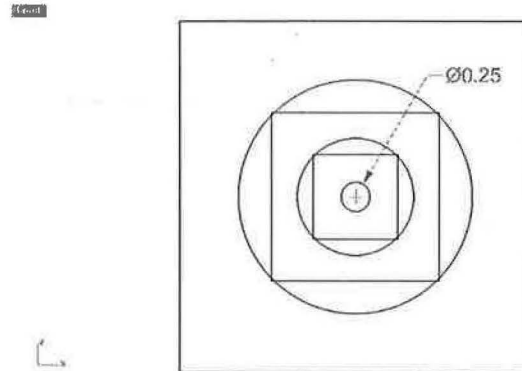

Figure 1f

9. Save the drawing
10. Save the drawing a second time as a dxf file (dxf files are commonly used with CAM software)
11. Use your CAM software to machine the captive cube
12. Import your dxf file into your CAM program (these steps will not be the same for all CAD/CAM software)
13. Select the largest circle
14. Create a POCKET TOOLPATH using a 1/4" end mill and the curve selected above as the boundary (the depth of the pocket is determined by measuring the distance from one rectangle to the next rectangle), figure 1g

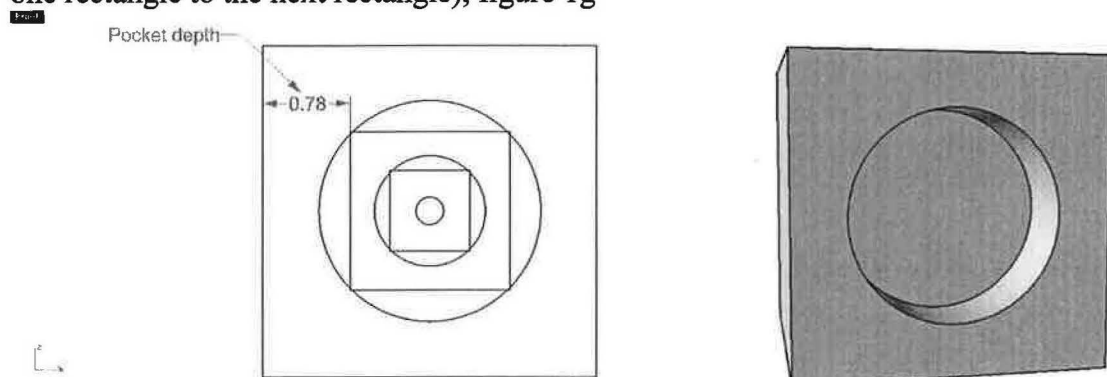

Figure 1g

15. Select the second largest circle
16. Create a POCKET TOOLPATH using a 1/4" end mill and the curve selected above as the boundary, figure 1h

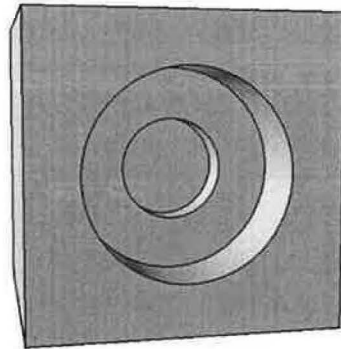

Figure 1h

17. Select the smallest circle

18. Create a POCKET TOOLPATH using a $\frac{1}{4}$ " end mill and the curve selected above as the boundary (this pocket should be at least half way through the cube), figure 1i

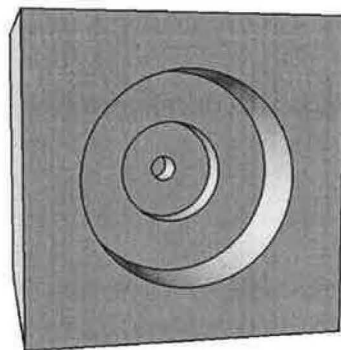

Figure 1i

19. Repeat steps 13-18 for all 6 sides of the cube to create the captive cube (you may want to make a jig to help support the cube when you get close to making your last few cuts), figure 1j

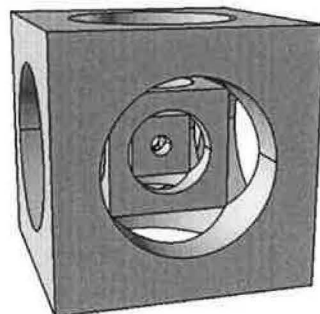

Figure 1j

20. The last step you will need to do is use a small blade (scroll saw blade) to cut the little parts of the interior cubes that are still connected

Creating a Geneva Gear Using the Milling Machine

Student Learning Targets

I can create a pair of Geneva Gears given a set of parameters

- I will do this by using Rhino (CAD)
- I will do this by using PartWorks (CAM)
- I will demonstrate this by creating a pair of Geneva Gears that meet the given parameters
- This means I can accurately read a technical drawing
- This means I can accurately cast a part using a mold,
- This means I can accurately generate toolpaths
- This means I can accurately and safely operate a CNC milling machine

THIS IS A 4 STEP ASSIGNMENT

- **Step 1**= cut male parts using ShopBot
- **Step 2**= pour Silicone into the part you just machined, creating a female mold
- **Step 3**= pour Resin into the female mold you made in step 2, resulting into new Geneva Gear parts
- **Step 4**= cut a base to set your Geneva Gear parts on to see if they work

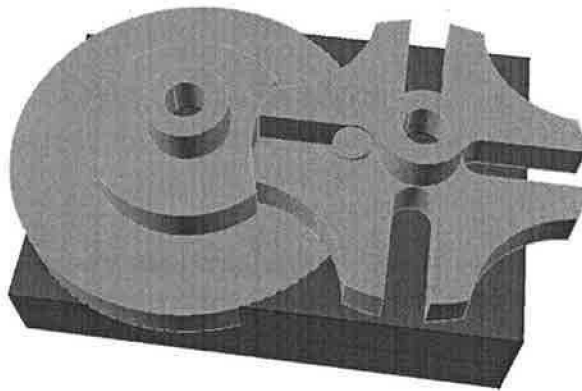

Learning Outcome

In this project the student will learn how a Geneva mechanism works. A Geneva mechanism is a timing device used in projectors, clocks, watches, etc. The student will learn how to read a technical drawing. They will also be introduced to mold making as they make a silicone mold. The student will then create Geneva gear parts using resin. Last, the student will test their Geneva mechanism to see if it works.

STEP 1: Cutting male Geneva Gear parts**Design Parameters**

- Must cut the male Geneva Gear parts using the ShopBot
- Must use a 1/4" straight bit (select from SB starter set in PartWorks)
- Parts must be centered on a 1 1/4"x 3 1/2"x 5 1/2" piece of wax
- Must leave 1/4" wall around outside of piece of wax to hold Silicone in when poured
- Must use 1/8" step downs
- See below for example

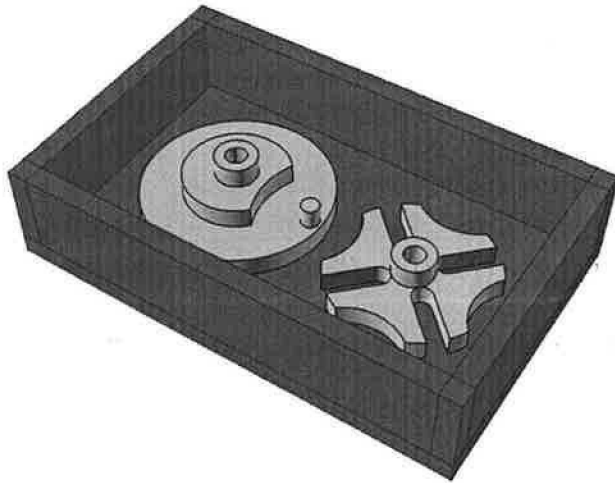
**STEP 2: Pour Silicone to form female mold**

- See teacher to discuss this step

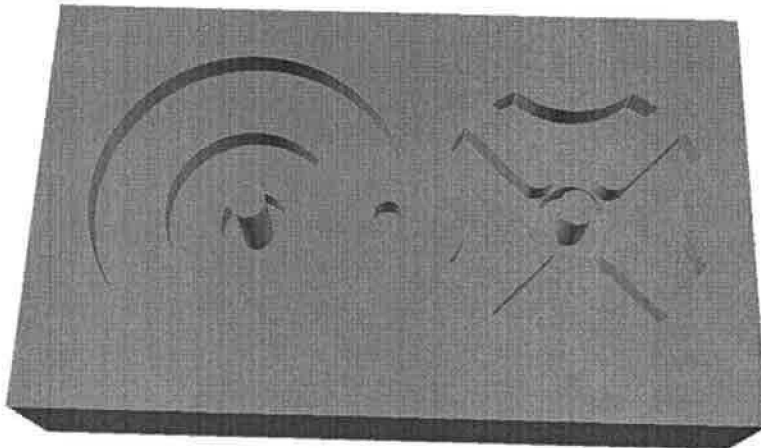

STEP 3: Pour Resin into mold to create new Geneva Gear parts

- See teacher to discuss this step

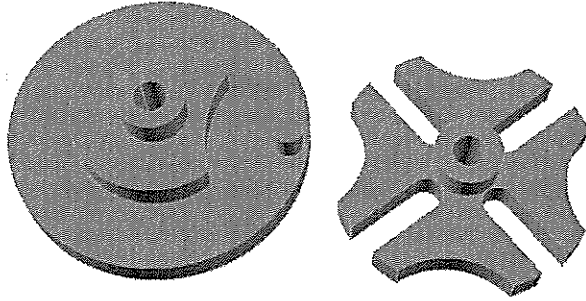
**STEP 4: Cut a base to set your Geneva Gears on to see if they work**Design Parameters

- Must cut a base using the ShopBot
- Must use a 1/4" straight bit (select from SB starter set in PartWorks)
- Must use 1/8" step downs
- Must cut out of a 1"x 3"x 2" piece of wax
- See below for example

Perspective

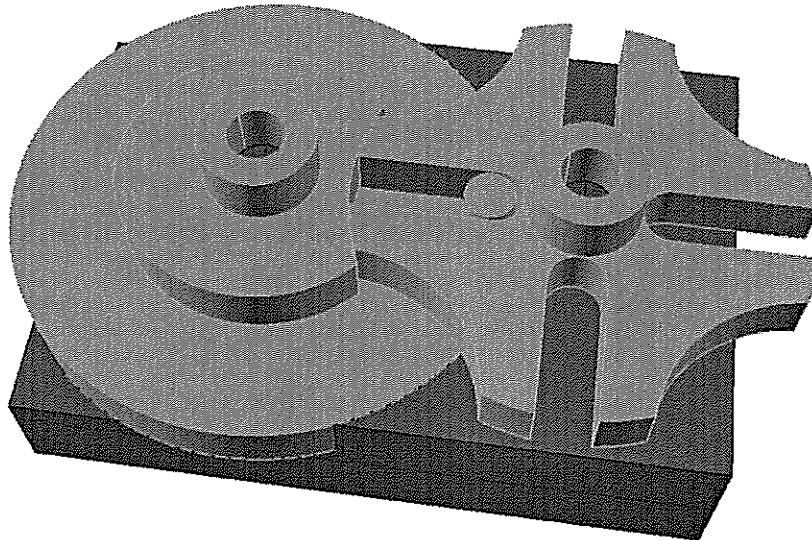

The Following Must be Turned in with the Geneva Gear Project

Turn in project in the following order

- Project cover page
- Completed questions below (**there is a pre-machining activity**)
- Machined set of Geneva Gears placed on base to check for accuracy

Complete the Following Questions for the Geneva Gear Project YOU MUST SHOW ALL MATH TO RECEIVE CREDIT!!!

Pre-machining activity

1. Before machining the male gear parts in step 1, determine the displacement of water for the rough block of material you are starting with. To do this do the following:

- Fill a graduated cylinder with 500 mL of water
- Place your material/part into the graduated cylinder
- Record the reading of the graduated cylinder below (nearest mL)

Record your water level here: ___ mL

Post-machining activity

1. Determine the displacement of water for the machined block of material in step 1.

Record your water level here: ___ mL

2. Determine the amount of Silicone you will need to mix up to pour into the male mold for step 2(forming a female Silicone mold) (nearest .01 mL)

3. In order to make Silicone you must mix a 1:9 ratio of catalyst to Silicone.

- How many mL of catalyst do you need to mix to create the female mold above
___ mL

- How many mL of Silicone do you need to mix to create the female mold above
___ mL

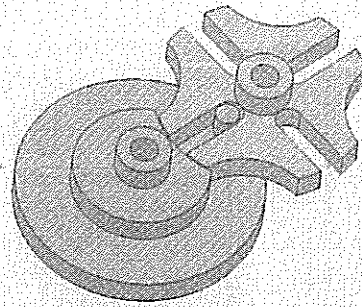
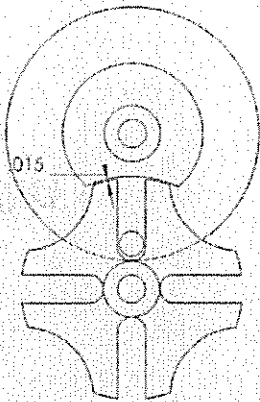

| ITEM NO. | PART NUMBER | MATERIAL | QTY. |
|----------|--------------|----------|------|
| 1 | GENEVA GEAR | Balsa | 1 |
| 2 | CAM FOLLOWER | Maple | 1 |

| | | | | | |
|-------------------|---------|----------------------|------------|---------------|----------|
| KELSO HIGH SCHOOL | | GENEVA GEAR ASSEMBLY | | DATE: | ID CODE: |
| DR. BY: | CK. BY: | AP. BY: | SCALE: 1:1 | SHEET: 1 OF 3 | DWG. NO. |

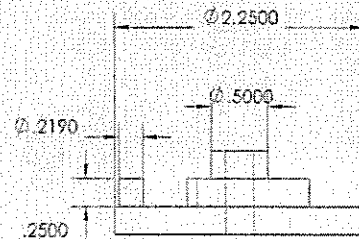
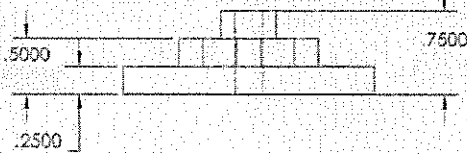
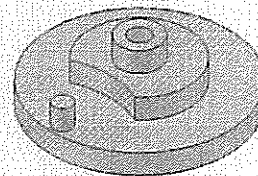
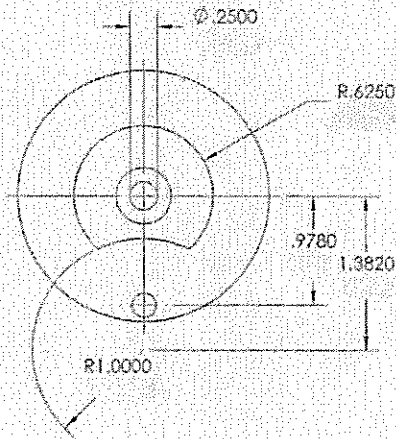

| | | | | | |
|-------------------|---------|--------------|------------|---------------|----------|
| KELSO HIGH SCHOOL | | CAM FOLLOWER | | DATE: | ID CODE: |
| DR. BY: | CK. BY: | AP. BY: | SCALE: 1:1 | SHEET: 2 OF 3 | DWG. NO. |

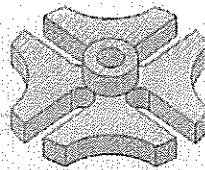
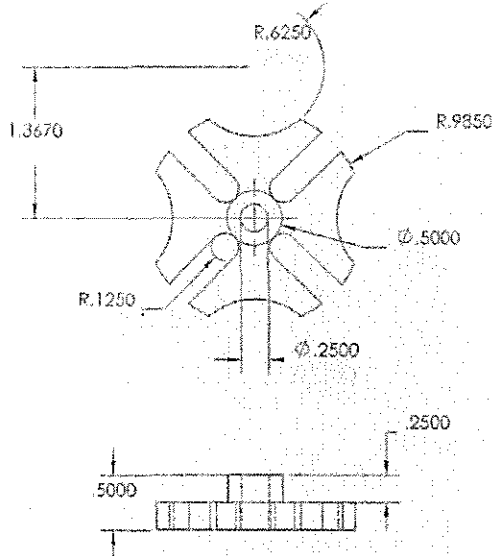

| | | | | | |
|-------------------|---------|-------------|-------------|---------------|----------|
| KELSO HIGH SCHOOL | | GENEVA GEAR | | DATE: | ID CODE: |
| DR. BY: | CK. BY: | AP. BY: | SCALE: 1: 1 | SHEET: 3 OF 3 | DWG. NO. |

APPENDIXES

Appendix A

Curriculum and Standards Alignment

| Project | CAD 15.1301 Foundation Standards | CAD 15.1301 Career Strand Standards | College-Readiness Standards for Mathematics |
|------------|---|--|---|
| Box | 1.01,1.04,2.01,3.01, 3.02,6.01,8.01,8.06, 9.01,9.02 | 1.01,6.01,6.02,7.01,7.02, 7.03,7.04,8.01,8.02,8.03, 8.04,8.05,8.06,8.07,9.01, 9.08,9.01,11.01,11.02, 11.03,11.04,11.06,11.07, 11.08,11.09,12.01,12.04, 12.05,12.06,12.07,13.01, 13.02,13.03,13.04,13.05, 13.06,14.01,14.02,14.03, 14.04,14.05,14.06,14.08, 15.01,15.02,16.01,16.02, 16.03,16.04,16.06,16.07, 16.08,16.09,17.01 | 1.1,1.2,1.3,2.1,2.3, 3.1,3.2,3.3,4.1,4.2, 4.3,5.1,5.2,5.3,7.1, 7.2,7.3 |
| Protractor | 1.01,1.04,2.01,3.01, 3.02,6.01,8.01,8.06, 9.01,9.02 | 1.01,6.01,6.02,7.01,7.02, 7.03,7.04,8.01,8.02,8.03, 8.04,8.05,8.06,8.07,9.01, 9.08,9.01,11.01,11.02, 11.03,11.04,11.05,11.06, 11.07,11.08,11.09,12.01, 12.04,12.05,12.06,12.07, 13.01,13.02,13.03,13.04, 13.05,13.06,14.01,14.02, 14.03,14.04,14.05,14.06, 15.01,15.02,16.01,16.02, 16.03,16.04,16.06,16.07, 16.08,16.09,17.01 | 1.3,2.1,2.3,3.1,3.2, 3.3,4.1,5.1,5.2,5.3 |
| Ruler | 1.01,1.04,2.01,3.01, 3.02,6.01,8.01,8.06, 9.01,9.02 | 1.01,6.01,6.02,7.01,7.02, 7.03,7.04,8.01,8.02,8.03, 8.04,8.05,8.06,8.07,9.01, 9.08,,11.01,11.02,11.03, 11.04,11.06,11.07,11.08, 11.09,12.01,12.04,12.05, 12.06,12.07,13.01,13.02, 13.03,13.04,13.05,13.06, 14.01,14.02,14.03,14.04, 14.05,14.06,15.01,15.02, | 1.3,2.1,2.3,3.1,3.2, 3.3,4.1,4.2,5.1,5.2, 5.3,7.1,7.2,7.3 |

| | | | |
|------------------|---|---|---|
| | | 16.01,16.02,16.03,16.04, 16.06,16.07,16.08,16.09, 17.01 | |
| Pi Tape | 1.01,1.04,2.01,3.01, 3.02,6.01,8.01,8.06, 9.01,9.02 | 1.01,6.01,6.02,7.01,7.02, 7.03,7.04,8.01,8.02,8.03, 8.04,8.05,8.06,8.07,9.01, 9.08,11.01,11.02,11.03, 11.04,11.06,11.07,11.08, 11.09,12.01,12.04,12.05, 12.06,12.07,13.01,13.02, 13.03,13.04,13.05,13.06, 14.01,14.02,14.03,14.04, 14.05,14.06,15.01,15.02, 16.01,16.02,16.03,16.04,16 .06,16.07,16.08,16.09, 17.01 | 1.3,2.1,2.3,3.1,3.2, 3.3,3.4,4.1,4.2,5.1, 5.2,5.3,7.1,7.2,7.3 |
| Golf Ball Box | 1.01,1.04,2.01,3.01, 3.02,4.01,4.03,6.01, 8.01,8.06,9.01,9.02 | 1.01,6.01,6.02,7.01,7.02, 7.03,7.04,8.01,8.02,8.03, 8.04,8.05,8.06,8.07,9.01, 9.08,10.03,11.01,11.02, 11.03,11.04,11.05,11.06, 11.07,11.08,11.09,12.01, 12.04,12.05,12.06,12.07, 13.01,13.02,13.03,13.04, 13.05,13.06,14.01,14.02, 14.03,14.04,14.05,14.06, 14.08,15.01,15.02,16.01, 16.02,16.03,16.04,16.06, 16.07,16.08,16.09,17.01 | 1.1,1.2,1.3,2.1,2.3, 3.1,3.2,3.3,4.1,4.2, 5.1,5.2,5.3,7.1,7.2, 7.3 |
| Star | 1.01,1.04,2.01,3.01, 3.02,6.01,8.01,8.06, 9.01,9.02 | 1.01,6.01,6.02,7.01,7.02, 7.03,7.04,8.01,8.02,8.03, 8.04,8.05,8.06,8.07,9.01, 9.08,10.03,11.01,11.02, 11.03,11.04,11.06,11.07, 11.08,11.09,12.01,12.04, 12.05,12.06,12.07,13.01, 13.02,13.03,13.04,13.05, 13.06,14.01,14.02,14.03, 14.05,14.06,15.01,15.02, 16.01,16.02,16.03,16.04, 16.06,16.07,16.08,16.09, 17.01 | 1.1,1.2,1.3,2.1,2.3, 3.1,3.2,3.3,4.1,4.2, 5.1,5.2,5.3,7.1,7.2, 7.3 |
| Y-tube | 1.01,1.04,2.01,3.01, 3.02,6.01,8.01,8.06, 9.01,9.02 | 1.01,6.01,6.02,7.01,7.02, 7.03,7.04,8.01,8.02,8.03, 8.04,8.05,8.06,8.07,9.01, | 1.1,1.2,1.3,2.1,2.3, 3.1,3.2,3.3,4.1,4.2, 4.3,5.1,5.2,5.3,7.1, |

| | | | |
|----------------|---|---|---|
| | | 9.08,10.03,11.01,11.02, 11.03,11.04,11.06,11.07, 11.08,11.09,12.01,12.04, 12.05,12.06,12.07,13.01, 13.02,13.03,13.04,13.05, 13.06,14.01,14.02,14.03, 14.04,14.05,14.06,14.08, 15.01,15.02,16.01,16.02, 16.03,16.04,16.06,16.07, 16.08,16.09,17.01 | 7.2,7.3 |
| Inlay Initials | 1.01,1.04,2.01,3.01, 3.02,6.01,8.01,8.06, 9.01,9.02 | 1.01,6.01,6.02,7.01,7.02, 7.03,7.04,8.01,8.02,8.03, 8.04,8.05,8.06,8.07,9.01, 9.08,11.01,11.02,11.03, 11.04,11.06,11.07,11.08, 11.09,12.01,12.04,12.05, 12.06,12.07,13.01,13.02, 13.03,13.04,13.05,13.06, 14.01,14.02,14.03,14.05, 14.06,14.04,14.08,15.01, 15.02,16.01,16.02,16.03, 16.04,16.06,16.07,16.08, 16.09,17.01 | 1.1,1.2,1.3,2.1,2.2, 2.3,3.1,3.2,3.3,4.1, 4.2,5.1,5.2,7.1,7.2, 7.3 |
| Laser Lego | 1.01,1.04,2.01,3.01, 3.02,6.01,8.01,8.06, 9.01,9.02 | 1.01,6.01,6.02,7.01,7.02, 7.03,7.04,8.01,8.02,8.03, 8.04,8.05,8.06,8.07,9.01, 9.08,10.03,11.01,11.02, 11.03,11.04,11.05,11.06, 11.07,11.08,11.09,12.01, 12.04,12.05,12.06,12.07, 13.01,13.02,13.03,13.04, 13.05,13.06,14.01,14.02, 14.03,14.05,14.06,14.08, 15.01,15.02,16.01,16.02, 16.03,16.04,16.06,16.07, 16.08,16.09,17.01 | 1.1,1.2,1.3,2.1,2.2, 2.3,3.1,3.2,3.3,4.1, 4.2,5.1,5.2,7.1 |
| Gears | 1.01,1.04,2.01,3.01, 3.02,6.01,8.01,8.06, 9.01,9.02 | 1.01,6.01,6.02,7.01,7.02, 7.03,7.04,8.01,8.02,8.03, 8.04,8.05,8.06,8.07,9.01, 9.08,11.01,11.02,11.03, 11.04,11.06,11.07,11.08, 11.09,12.01,12.04,12.05, 12.06,12.07,13.01,13.02, 13.03,13.04,13.05,13.06, 14.01,14.02,14.03,14.05, | 1.1,1.2,1.3,2.1,2.3, 3.1,3.2,3.3,3.4,4.1, 4.2,5.1,5.2,5.3,7.1, 7.2,7.3 |

| | | | |
|------------------------------|---|---|---|
| | | 14.06,14.08,15.01,15.02, 16.01,16.02,16.03,16.04, 16.06,16.07,16.08,16.09, 17.01 | |
| Cabin | 1.01,1.04,2.01,3.01, 3.02,6.01,8.01,8.06, 9.01,9.02 | 1.01,2.01,5.01,6.01,6.02, 7.01,7.02,7.03,7.04,8.01, 8.02,8.03,8.04,8.05,8.06, 8.07,9.01,9.08,10.03,11.01, 11.02,11.03,11.04,11.06, 11.07,11.08,11.09,12.01, 12.04,12.05,12.06,12.07, 13.01,13.02,13.03,13.04, 13.05,13.06,14.01,14.02, 14.03,14.04,14.05,14.06, 14.08,15.01,15.02,16.01, 16.02,16.03,16.04,16.06, 16.07,16.08,16.09,17.01 | 1.1,1.2,1.3,2.1,2.2, 2.3,3.1,3.2,3.3,4.1, 4.2,5.1,5.2,5.3,7.1 |
| G&M-Square | 1.01,1.04,2.01,3.01, 3.02,6.01,8.01,8.06, 9.01,9.02 | 1.01,6.01,6.02,7.01,7.02, 7.03,7.04,8.01,8.02,8.03, 8.04,8.05,8.06,8.07,9.08, 11.01,11.02,11.03,11.04, 11.06,11.07,11.08,11.09, 12.01,12.04,12.05,12.06, 12.07,13.01,13.02,13.03, 13.04,13.05,13.06,14.01, 14.02,14.03,14.05,14.06, 15.01,15.02,16.01,16.02, 16.03,16.04,16.06,16.07, 16.08,16.09,17.01 | 1.1,1.2,1.3,2.1,2.2, 2.3,3.1,3.2,3.3,3.4, 4.1,4.2,5.1,5.2,5.3, 7.1 |
| G&M-House | 1.01,1.04,2.01,3.01, 3.02,6.01,8.01,8.06, 9.01,9.02 | 1.01,6.01,6.02,7.01,7.02, 7.03,7.04,8.01,8.02,8.03, 8.04,8.05,8.06,8.07,9.08, 11.01,11.02,11.03,11.04, 11.06,11.07,11.08,11.09, 12.01,12.04,12.05,12.06, 12.07,13.01,13.02,13.03, 13.04,13.05,13.06,14.01, 14.02,14.03,14.05,14.06, 15.01,15.02,16.01,16.02, 16.03,16.04,16.06,16.07, 16.08,16.09,17.01 | 1.1,1.2,1.3,2.1,2.2, 2.3,3.1,3.2,3.3,3.4, 4.1,4.2,5.1,5.2,5.3, 7.1 |
| G&M-Square, Circle, Triangle | 1.01,1.04,2.01,3.01, 3.02,6.01,8.01,8.06, 9.01,9.02 | 1.01,6.01,6.02,7.01,7.02, 7.03,7.04,8.01,8.02,8.03, 8.04,8.05,8.06,8.07,9.08, 11.01,11.02,11.03,11.04, | 1.1,1.2,1.3,2.1,2.2, 2.3,3.1,3.2,3.3,3.4, 4.1,4.2,5.1,5.2,5.3, 7.1 |

| | | | |
|--|--|--|---|
| | | 11.06,11.07,11.08,11.09, 12.01,12.04,12.05,12.06, 12.07,13.01,13.02,13.03, 13.04,13.05,13.06,14.01, 14.02,14.03,14.05,14.06, 15.01,15.02,16.01,16.02, 16.03,16.04,16.06,16.07, 16.08,16.09,17.01 | |
| G&M-Name | 1.01,1.04,2.01,3.01, 3.02,6.01,8.01,8.06, 9.01,9.02 | 1.01,6.01,6.02,7.01,7.02, 7.03,7.04,8.01,8.02,8.03, 8.04,8.05,8.06,8.07,9.08, 11.01,11.02,11.03,11.04, 11.06,11.07,11.08,11.09, 12.01,12.04,12.05,12.06, 12.07,13.01,13.02,13.03, 13.04,13.05,13.06,14.01, 14.02,14.03,14.05,14.06, 15.01,15.02,16.01,16.02, 16.03,16.04,16.06,16.07, 16.08,16.09,17.01 | 1.1,1.2,1.3,2.1,2.2, 2.3,3.1,3.2,3.3,3.4, 4.1,4.2,5.1,5.2,5.3, 7.1 |
| Square,Circle ,Triangle- Male/Female | 1.01,1.04,2.01,3.01, 3.02,5.01,6.01,8.01, 8.06,9.01,9.02 | 1.01,6.01,6.02,7.01,7.02, 7.03,7.04,8.01,8.02,8.03, 8.04,8.05,8.06,8.07,9.08, 11.01,11.02,11.03,11.04, 11.05,11.06,11.07,11.08, 11.09,12.01,12.04,12.05, 12.06,12.07,13.01,13.02, 13.03,13.04,13.05,13.06, 14.01,14.02,14.03,14.05, 14.06,15.01,15.02,16.01, 16.02,16.03,16.04,16.05, 16.06,16.07,16.08,16.09, 17.01 | 1.1,1.2,1.3,2.1,2.2, 2.3,3.1,3.2,3.3,3.4, 4.1,4.2,4.3,5.1,5.2, 5.3,7.1,7.2,7.3 |
| Keychain | 1.01,1.04,2.01,3.01, 3.02,5.01,6.01,8.01, 8.06,9.01,9.02 | 1.01,6.01,6.02,7.01,7.02, 7.03,7.04,8.01,8.02,8.03, 8.04,8.05,8.06,8.07,9.03, 9.08,11.01,11.02,11.03, 11.04,11.05,11.06,11.07, 11.08,11.09,12.01,12.04, 12.05,12.06,12.07,13.01, 13.02,13.03,13.04,13.05, 13.06,14.01,14.02,14.03, 14.05,14.06,15.01,15.02, 16.01,16.02,16.03,16.04, 16.05,16.06,16.07,16.08, | 1.1,1.2,1.3,2.1,2.2, 2.3,3.1,3.2,3.3,3.4, 4.1,4.2,5.1,5.2,5.3, 7.1,7.2,7.3 |

| | | | |
|------------|--|---|---|
| | | 16.09,17.01 | |
| Calculator | 1.01,1.04,2.01,3.01, 3.02,5.01,6.01,8.01, 8.06,9.01,9.02 | 1.01,6.01,6.02,7.01,7.02, 7.03,7.04,8.01,8.02,8.03, 8.04,8.05,8.06,8.07,9.03, 9.08,11.01,11.02,11.03, 11.04,11.05,11.06,11.07, 11.08,11.09,12.01,12.04, 12.05,12.06,12.07,13.01, 13.02,13.03,13.04,13.05, 13.06,14.01,14.02,14.03, 14.05,14.06,15.01,15.02, 16.01,16.02,16.03,16.04, 16.05,16.06,16.07,16.08, 16.09,17.01 | 1.1,1.2,1.3,2.1,2.2, 2.3,3.1,3.2,3.3,3.4, 4.1,4.2,5.1,5.2,5.3, 7.1 |
| Gasket | 1.01,1.04,2.01,3.01, 3.02,5.01,6.01,8.01, 8.06,9.01,9.02 | 1.01,6.01,6.02,7.01,7.02, 7.03,7.04,8.01,8.02,8.03, 8.04,8.05,8.06,8.07,9.01, 9.08,11.01,11.02,11.03, 11.04,11.06,11.07,11.08, 11.09,12.01,12.04,12.05, 12.06,12.07,13.01,13.02, 13.03,13.04,13.05,13.06, 14.01,14.02,14.03,14.05, 14.06,15.01,15.02,16.01, 16.02,16.03,16.04,16.06, 16.07,16.08,16.09,17.01 | 1.1,1.2,1.3,2.1,2.3, 3.1,3.2,3.3,3.4,4.1, 4.2,4.3,5.1,5.2,5.3, 7.1,7.2,7.3 |
| Cam | 1.01,1.04,2.01,3.01, 3.02,5.01,6.01,8.01, 8.06,9.01,9.02 | 1.01,6.01,6.02,7.01,7.02, 7.03,7.04,8.01,8.02,8.03, 8.04,8.05,8.06,8.07,9.01, 9.08,11.01,11.02,11.03, 11.04,11.06,11.07,11.08, 11.09,12.01,12.04,12.05, 12.06,12.07,13.01,13.02, 13.03,13.04,13.05,13.06, 14.01,14.02,14.03,14.05, 14.06,15.01,15.02,16.01, 16.02,16.03,16.04,16.06, 16.07,16.08,16.09,17.01 | 1.1,1.2,1.3,2.1,2.2, 2.3,3.1,3.2,3.3,4.1, 4.2,5.1,5.2,5.3,7.1 |
| Frisbee | 1.01,1.04,2.01,3.01, 3.02,5.01,6.01,8.01, 8.06,9.01,9.02 | 1.01,6.01,6.02,7.01,7.02, 7.03,7.04,8.01,8.02,8.03, 8.04,8.05,8.06,8.07,9.01, 9.08,11.01,11.02,11.03, 11.04,11.06,11.07,11.08, 11.09,12.01,12.04,12.05, 12.06,12.07,13.01,13.02, | 1.1,1.2,1.3,2.1,2.2, 2.3,3.1,3.2,3.3,4.1,4 .2,5.1,5.2,5.3,7.1 |

| | | | |
|----------------------------|---|--|---|
| | | 13.03,13.04,13.05,13.06, 14.01,14.02,14.03,14.05, 14.06,15.01,15.02,16.01, 16.02,16.03,16.04,16.06, 16.07,16.08,16.09,17.01 | |
| Milling Machine Lego | 1.01,1.04,2.01,3.01, 3.02,5.01,6.01,8.01, 8.06,9.01,9.02 | 1.01,6.01,6.02,7.01,7.02, 7.03,7.04,8.01,8.02,8.03, 8.04,8.05,8.06,8.07,9.01, 9.08,11.01,11.02,11.03, 11.04,11.05,11.06,11.07, 11.08,11.09,12.01,12.04, 12.05,12.06,12.07,13.01, 13.02,13.03,13.04,13.05, 13.06,14.01,14.02,14.03, 14.05,14.06,15.01,15.02, 16.01,16.02,16.03,16.04, 16.06,16.07,16.08,16.09, 17.01 | 1.1,1.2,1.3,2.1,2.3, 3.1,3.2,3.3,4.1,4.2, 5.1,5.2,5.3,7.1 |
| Adaptive Device | 1.01,1.04,1.05,2.01, 3.01,3.02,5.01,6.01, 8.01,8.06,9.01,9.02 | 1.01,2.01,4.02,5.01,6.01, 6.02,7.01,7.02,7.03,7.04, 8.01,8.02,8.03,8.04,8.05, 8.06,8.07,9.01,9.08,10.01, 11.01,11.02,11.03,11.04, 11.05,11.06,11.07,11.08, 11.09,12.01,12.04,12.05, 12.06,12.07,13.01,13.02, 13.03,13.04,13.05,13.06, 14.01,14.02,14.03,14.04, 14.05,14.06,14.08,15.01, 15.02,16.01,16.02,16.03, 16.04,16.06,16.07,16.08, 16.09,17.01 | 1.1,1.2,1.3,2.1,2.2, 2.3,3.1,3.2,3.3,4.1, 4.2,5.1,5.2,5.3,7.1 |
| Small Box | 1.01,1.04,1.05,2.01, 3.01,3.02,5.01,6.01, 8.01,8.06,9.01,9.02 | 1.01,6.01,6.02,7.01,7.02, 7.03,7.04,8.01,8.02,8.03, 8.04,8.05,8.06,8.07,9.01, 9.08,10.01,11.01,11.02, 11.03,11.04,11.06,11.07, 11.08,11.09,12.01,12.04, 12.05,12.06,12.07,13.01, 13.02,13.03,13.04,13.05, 13.06,14.01,14.02,14.03, 14.04,14.05,14.06,14.08, 15.01,15.02,16.01,16.02, 16.03,16.04,16.06,16.07, 16.08,16.09,17.01 | 1.1,1.2,1.3,2.1,2.2, 2.3,3.1,3.2,3.3,4.1, 4.2,5.1,5.2,5.3,7.1 |

| | | | |
|--------------|--|---|---|
| Square Cube | 1.01,1.04,2.01,3.01, 3.02,5.01,6.01,8.01, 8.06,9.01,9.02 | 1.01,6.01,6.02,7.01,7.02,7. 03,7.04,8.01,8.02,8.03,8.04 ,8.05,8.06,8.07,9.08,11.01, 11.02,11.03,11.04,11.06,11 .07,11.08,11.09,12.01,12.0 4,12.05,12.06,12.07,13.01, 13.02,13.03,13.04,13.05,13 .06,14.01,14.02,14.03,14.0 5,14.06,15.01,15.02,16.01, 16.02,16.03,16.04,16.06,16 .07,16.08,16.09,17.01 | 1.1,1.2,1.3,2.1,2.2, 2.3,3.1,3.2,3.3,4.1, 4.2,4.3,5.1,5.2,5.3, 7.1 |
| Captive Cube | 1.01,1.04,2.01,3.01, 3.02,5.01,6.01,8.01, 8.06,9.01,9.02 | 1.01,6.01,6.02,7.01,7.02, 7.03,7.04,8.01,8.02,8.03, 8.04,8.05,8.06,8.07,9.01, 9.08,11.01,11.02,11.03, 11.04,11.05,11.06,11.07, 11.08,11.09,12.01,12.04, 12.05,12.06,12.07,13.01, 13.02,13.03,13.04,13.05, 13.06,14.01,14.02,14.03, 14.05,14.06,15.01,15.02, 16.01,16.02,16.03,16.04, 16.06,16.07,16.08,16.09, 17.01 | 1.1,1.2,1.3,2.1,2.2, 2.3,3.1,3.2,3.3,4.1, 4.2,5.1,5.2,5.3,7.1 |
| Geneva Gear | 1.01,1.04,2.01,3.01, 3.02,5.01,6.01,8.01, 8.06,9.01,9.02 | 1.01,6.01,6.02,7.01,7.02, 7.03,7.04,8.01,8.02,8.03, 8.04,8.05,8.06,8.07,9.01, 9.08,11.01,11.02,11.03, 11.04,11.05,11.06,11.07, 11.08,11.09,12.01,12.04, 12.05,12.06,12.07,13.01, 13.02,13.03,13.04,13.05, 13.06,14.01,14.02,14.03, 14.05,14.06,15.01,15.02, 16.01,16.02,16.03,16.04, 16.06,16.07,16.08,16.09, 17.01 | 1.1,1.2,1.3,2.1,2.2, 2.3,3.1,3.2,3.3,4.1, 4.2,4.3,5.1,5.2,5.3, 7.1,7.2,7.3 |

Appendix B

Mathematics Formulas

Area of a rectangle

Area= lw
 l = length
 w = width

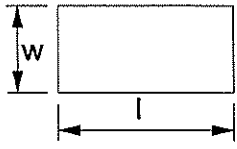

Area of a rectangle

Area= lw
 $A = 4'' \times 2''$
 $A = 8 \text{ in}^2$

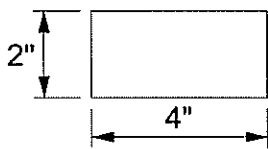

Area of a circle

Area= πr^2
 r = radius

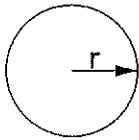

Area of a circle

Area= πr^2
 $A = 3.14 \times 4'' \times 4''$
 $A = 50.25 \text{ in}^2$

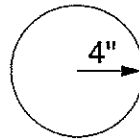

Area of a triangle

Area= $\frac{1}{2}bh$
 b = base
 h = height

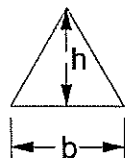

Area of a triangle

Area= $\frac{1}{2}bh$
 $A = \frac{1}{2} \times 4 \times 6$
 $A = 12 \text{ in}^2$

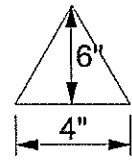

Area of a trapezoid

Area= $\frac{1}{2}(b_1 + b_2)h$
 b_1 = base 1
 b_2 = base 2
 h = height

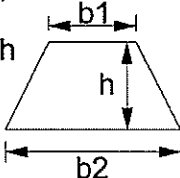

Area of a trapezoid

Area= $\frac{1}{2}(b_1 + b_2)h$
 $A = \frac{1}{2}(2 + 4)3$
 $A = 9 \text{ in}^2$

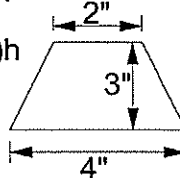

STEP

Volume of rectangular prism
 Volume= area of base x h
 Volume= $L \times w \times h$
 l= length
 w= width
 h= height



STEP

Volume of rectangular prism
 Volume= area of base x h
 Volume= $L \times w \times h$
 $V = 6'' \times 4'' \times 2''$
 $V = 48 \text{ in.}^3$

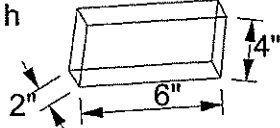

STEP

Volume of cylinder
 Volume= area of base x h
 $V = \pi r^2 h$

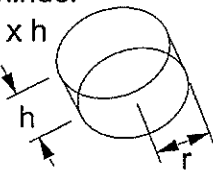

STEP

Volume of cylinder
 Volume= area of base x h
 $V = \pi r^2 h$
 $V = \pi 2'' \times 2'' \times 4''$
 $V = 50.24 \text{ in.}^3$

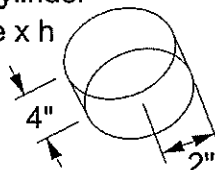

STEP

Volume of triangular prism
 Volume= area of base x h
 Volume= Bh
 $B = \frac{1}{2}bh$

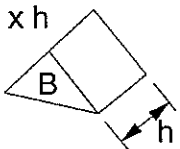

STEP

Volume of triangular prism
 Volume= area of base x h
 $V = Bh$
 $V = \frac{1}{2} \times 5'' \times 3'' \times 7''$
 $V = 52.5 \text{ in.}^3$

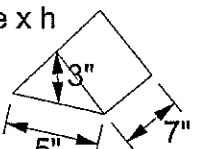

STEP

Volume of pyramid
 Volume= $\frac{1}{3}$ x area of base x h
 Volume= $\frac{1}{3}Bh$

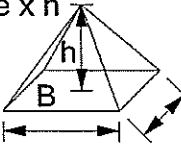

STEP

Volume of pyramid
 Volume= $\frac{1}{3}$ x area of base x h
 Volume= $\frac{1}{3}Bh$
 $V = \frac{1}{3} \times 2'' \times 2'' \times 4''$
 $V = 5.33 \text{ in.}^3$

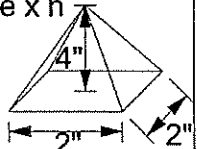

STEP

Volume of cone
 Volume= $\frac{1}{3}$ x area of base x h
 Volume= $\frac{1}{3}Bh$

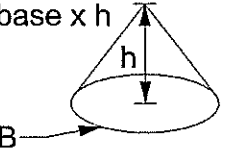

STEP

Volume of cone
 Volume= $\frac{1}{3}$ x area of base x h
 Volume= $\frac{1}{3}Bh$
 $V = \frac{1}{3} \times \pi \times 2'' \times 2'' \times 6''$
 $V = 25.12 \text{ in.}^3$

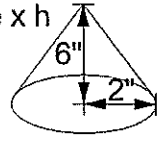

Perimeter of a rectangle

Perimeter = $2(l + w)$
 l = length
 w = width

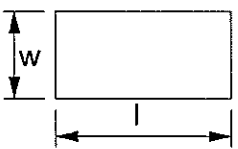

Perimeter of a rectangle

Perimeter = $2(l + w)$
 $P = 2(4'' + 2'')$
 $P = 12 \text{ in.}$

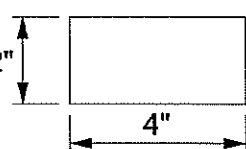

Circumference of a circle

Circumference = $2\pi r$ or πd
 r = radius
 d = diameter

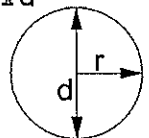

Circumference of a circle

Circumference = $2\pi r$ or πd
 $C = 2\pi 4''$ $C = \pi 8''$
 $C = 25.12''$ $C = 25.12''$

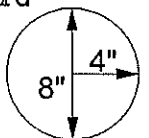

45-45-90 Triangle

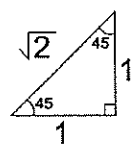

30-60-90 Triangle

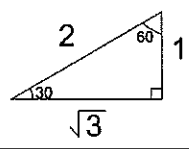

Pythagorean Theorem

$a^2 + b^2 = c^2$

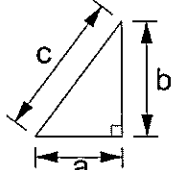

Pythagorean Theorem

$a^2 + b^2 = c^2$
 $(3 \times 3) + (4 \times 4) = c^2$
 $25 = c^2$
 $c = \sqrt{25}$
 $c = 5$

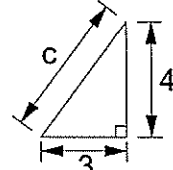

CHAPTER V

SUMMARY

In summary the need for CAD/CAM/CNC curriculum in Washington State was researched. A close look was taken at the manufacturing industry around the world. The benefits of using CAD/CAM/CNC in the manufacturing industry and the demand for operators were also evaluated. Efforts to providing skilled manufacturing employees and programs that teach CAD/CAM/CNC curriculum were viewed across the nation at both college and high school levels. Results showed a need for creating CAD/CAM/CNC curriculum for Washington State. Therefore, a workbook was created to provide teachers with a resource they can use in their classrooms. The workbook provides many projects that incorporate science, technology, engineering, and mathematics that meet Washington's mathematics course equivalency and General Drafting 15.1301 standards.

In the near future, the workbook will be distributed across the state of Washington at educational conferences. The workbook will be presented and distributed at the summer CAD workshops and next year at the WITEA and WASTS conferences. As a result of the curriculum in the workbook, Kelso High School's CAD program is in the process of being approved for a mathematics course equivalency. The program at Kelso has been implementing the workbook throughout the year and has seen a very positive impact in the classroom as a result.

Suggestions for Further Work

There are a lot of ideas and information that graduate students could do for further research. First of all, the workbook barely scratches the surface for what is possible with

CAD/CAM/CNC curriculum. There are a lot more CNC machines such as plasma cutters, vinyl cutters, lathes, and 3D printers that a person could develop curriculum for. Each of the machines are used for different applications and the projects and curriculum one could develop with such machines would greatly differ.

Another idea is to create a workbook for teachers that shows them how to set up, operate, and maintain their CNC machines. The workbook that was just created did not go into great detail of doing such. The tutorials in the workbook showed teachers how to use toolpaths and cut parts but did not go into how to select the cutters, the speeds to use, how to fasten down parts, how to zero the machines, or how to troubleshoot problems. These are just a few of many areas that could be further explained.

One last suggestion is to add answer sheets to the workbook that was just created. The reason the answer sheets were not created is because when the author drew up the projects they would not scale correctly in Microsoft Word. Some of the projects in the workbook involve measuring shapes. However if the teachers' computers are all set up or print to a slightly different scale the answers would be off. First of all, a person needs to figure out if there is a technique or software out that allows one to open documents to the same scale every time with any software they choose to use. If a person figures out how to do so then answer sheets would be consistent and accurate to use as an educational tool. However, this is just one of many things a person could do that relates to the project that was just completed. There truly is a lot of work left to do with CAD/CAM/CNC and all would be much appreciated to those who teach the subjects.

REFERENCES

- AFL-CIO Industrial Union Council. (2004). Washington State job exports: An analysis of
The role trade plays in manufacturing job loss. Washington, D.C. Author.
- An interview with Williard Daggett. (2008, October). *Techniques*, pp.12-13.
- Baltazar, W., & Millson, D. (1999, January). It's a classroom gas! *Tech Directions*. 30-32.
- Berry, R., Reed, P., Ritz, J., Lin, C., Hsiung, S., & Frazier, W. (2005, December/January). STEM initiatives: Stimulating students to improve science and mathematics achievement. *The Technology Teacher*. 23-29.
- Cassola, J. (2002, February). CNC preparation meets manufacturing opportunity. *Techniques*. 36-38.
- Conner, M. (2004, November). Jobs follow the market. *EDN Europe*. 102.
- Daggett, W. (2005, April). A central role for CTE in high school restructuring. *Techniques*. 56-58.
- Economic and Revenue Forecast Council. (2009). Washington economic and revenue forecast (Vol. 32, No. 1). Washington: Author.
- Educational rigor & relevance: An interview with Williard Daggett. (2005, September). *Techniques*, pp. 34-37.
- From bottleneck to breakthrough. (2008, April). *Modern Application News*, pp. 28-31.
- Giesecke, F., Mitchell, A., Spencer, H., Hill, I., Dygdon, J., Novak, J., et al. (2001). *Modern graphics communication (2nd ed.)*. Upper Saddle River, NJ: Prentice Hall.
- Honawar, V. (2005, September). U.S. leaders fret over students' math and science weaknesses. *Education Week*. 1-13.

Investing in America: The NAM's 2007 agenda (2007, January). Retrieved June 25, 2009

From <http://www.nam.org>

Lintz, J. (2004, November). CNC technology brings out hidden talents in disabled children. *Tech Directions*. 19-21.

Madsen, D., Madsen, D., & Turpin, J. (2007). *Engineering drawing and design*. New York: Delmar.

Mahazan, Vivek. (2004, January). American manufacturing is not dead. *Industrial Engineer*. 24.

Millson, D. (2002, November). Meeting modern manufacturing technology face-to-face. *Tech Directions*. 19-24.

Millson, D. (2003, November). They learn so their students can earn. *The Technology Teacher*. 23-26.

Modernization cuts cycle time in half. (2007, April). *Modern Applications News*, pp.46-49.

Mold maker finds success with CAD/CAM. (2006, August). *Modern Application News*, p.45.

Nanfara, F., Uccello, T., Murphy, D. (2002). *The CNC workshop (2nd ed.)*. Mission, Kansas: Schroff.

National Association of Manufacturers. (2008). *The DNA of America's manufacturing economy*. Washington, D.C.: Author.

O'Neil, J. (1995, May). On preparing students for the world of work: A conversation with Willard Daggett. *Educational Leadership*. 46-48.

Panella, J. (2007, April). CNC skills help carpentry students snare high-paying jobs. *Tech Directions*. 11-13.

Prepping the next generation of metalworkers. (2008, November). *Modern Application News*. pp. 30-33.

Reese, S. (2005, January). CAD/CAM: A new dimension in design and manufacturing. *Techniques*. 37-43.

Smith, S. (2003, September). Vital virtual hands-on learning. *Techniques*. 35-37.

State of Washington, Superintendent of Public Instruction. (2009). *Equivalency Credit Toolkit 3.0: An implementation guide for local school districts*. Olympia, WA: Author.

Technology prescription cures profit problems. (2006, May). *Modern Application News*, pp. 12-15.

The current state of the U.S. economy and manufacturing (2008, May). Retrieved June 25, 2009, from <http://www.nam.org>

Thottam, J. (2003, August). Where the good jobs are going. *Time*. 36-39.

Vavra, B. (2008, January). 2007 Salary survey: Global manufacturing salaries on the rise; job market tightens. *Plant Engineering*. 46-47.

Washington STEM initiative. Retrieved June 25, 2009, from <http://partnership4learning.org/stem>