

**QUICK MANUAL DESIGN OF SHELL AND
TUBE HEAT EXCHANGERS**

By

JAYESH MODI

Bachelor of Engineering

B.V.College of Engineering

University of Poona

Pune, India

1991

**Submitted to the Faculty of the
Graduate College of the
Oklahoma State University
in partial fulfilment of
the requirements for
the Degree of
MASTER OF SCIENCE
May, 1995**

**QUICK MANUAL DESIGN OF SHELL AND
TUBE HEAT EXCHANGERS**

Thesis Approved:

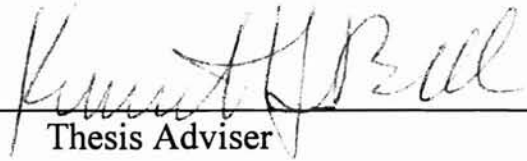

Thesis Adviser

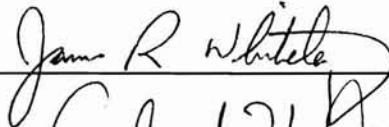

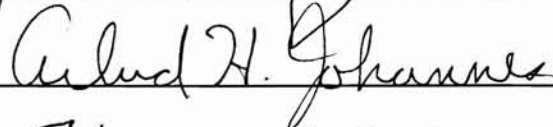

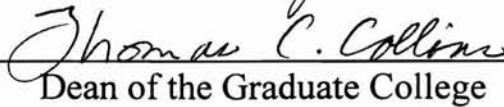

Dean of the Graduate College

PREFACE

The purpose of this thesis is to provide a general procedure to quickly estimate the approximate size of a shell and tube heat exchanger, including multiple shells in series and/or parallel, and dimensions required for entering rating calculations. This procedure is an expansion and refinement of the procedure given in Section 3.1.4 of the Heat Exchanger Design Handbook (Bell, 1983). The procedure is useful for a preliminary plant layout, cost estimation, and as a check on the output of computer-based design procedures.

Chapter 1 discusses the general usefulness of an approximate design method for shell and tube heat exchangers and describes both the essential and desirable features of such a method. A brief description of the components of a shell and tube heat exchanger, the various types of shell and bundle constructions, and the general selection criteria are also presented.

Chapter 2 deals with the basic structure of the design method. It includes a brief description of the concepts of conduction, convection and radiation. Also presented are procedures for the estimation of Q (total heat duty), MTD (mean temperature difference), individual film heat transfer coefficients (α 's) and overall heat transfer coefficient (U_o), and the number of shells required to perform the specified duty. The existing version of the design method, with its limitations, is also described.

In Chapter 3, the relationship of the heat transfer area, A , to the basic shell dimensions (shell inside diameter and effective tube length) is developed. A generalization of the outside area/shell dimensions relationship for the reference case to other tube sizes and

layouts, bundle types, number of tube side passes and finned tube dimensions is also developed.

Chapter 4 presents a procedure for the estimation of tube counts. An approximate method for estimating the baffle cut and baffle spacing as a function of the shell inside diameter is also presented. Vibration limitations are also described.

The Summary and Conclusions are given in Chapter 5 and Recommendations in Chapter 6. The use of the approximate design method is illustrated in the form of an example problem in the appendix. Also given are various tables for the estimation of film and overall coefficients for various cases, fouling factors, dimensions of bare and finned tubes and detailed tables and plots for the estimation of the correction factors.

ACKNOWLEDGMENTS

At the very outset, I would like to thank my major advisor, Dr. Ken Bell for his invaluable comments, constructive criticism and guidance and unlimited patience. My sincere appreciation extends to Dr. Karen High and Dr. Rob Whiteley, for agreeing to serve on my committee. I would like to thank Dr. Arland Johannes (A J) whose guidance, encouragement, and friendship are also invaluable.

I would also like to take this opportunity to thank my family for their encouragement. I would also like to give my special appreciation to my friends, especially Lindsay, Steven, Kanchana, Suresh and Rohit for their precious suggestions to my research.

Last but not the least, I would like to thank all the secretaries of the School of Chemical Engineering for their immense help and CEAT for the use of their facilities.

TABLE OF CONTENTS

Chapter	Page
I. SHELL AND TUBE HEAT EXCHANGERS	1
Introduction.....	1
Shell and Tube Heat Exchangers	3
Components	9
Selection Criteria	12
Finned Tube Heat Exchangers	12
II. BASIC STRUCTURE OF THE DESIGN METHOD	15
Modes of Heat Transfer	15
Film Heat Transfer Coefficient.....	17
Overall Heat Transfer Coefficient.....	18
Basic Design Equation.....	24
Calculation of Total Heat Duty.....	26
Logarithmic Mean Temperature Difference	26
Mean Temperature Difference	30
Number of Shell Required	34
Heat Transfer Area.....	36
Extension of "Base Case" to Other Shell/Bundle/Tube Geometries.....	39
Limitations of the Existing Version.....	40
III. CORRECTION FACTORS ESTIMATION.....	41
Introduction.....	41
Correction Factor for Unit Cell Tube Array	42
Correction Factor for Number of Tube-side Passes.....	46
Correction Factor for Shell Construction/Tube-bundle Layout Type.....	48
Correction Factor for Finned-tube Heat Exchangers	50
Estimation of Equivalent Area.....	53
Effective Tube Length and Shell Diameter.....	54

Chapter	Page
IV. PARAMETER ESTIMATION.....	55
Estimation of Tube Counts	55
Estimation of Baffle Cut and Baffle Spacing	57
Tube Vibrations	61
Mechanisms of Tube Vibrations.....	62
V. SUMMARY AND CONCLUSIONS	64
Summary	64
Conclusions.....	66
VI. RECOMMENDATIONS.....	68
BIBLIOGRAPHY	69
APPENDICES	73
APPENDIX A--TYPICAL OVERALL AND INDIVIDUAL DESIGN COEFFICIENTS FOR SHELL AND TUBE HEAT EXCHANGERS.....	74
APPENDIX B--EXAMPLE PROBLEM.....	84
APPENDIX C--CHARACTERISTICS OF TUBING.....	91
APPENDIX D--DIMENSIONS OF FINNED TUBES	92
APPENDIX E--TUBE COUNT TABLES	95
APPENDIX F--CALCULATIONS FOR FACTOR F_1	101
APPENDIX G--DETAILED TABLES FOR F_2	104
APPENDIX H--DETAILED TABLES FOR F_3	110
APPENDIX I--TABLES AND PLOTS FOR ESTIMATION OF F_p	115
APPENDIX J--PLOTS FOR ESTIMATION OF BAFFLE SPACING.....	122

:

LIST OF TABLES

Table	Page
I. Features of Principal Shell and Tube Heat Exchanger Designs	10
II. Correction Factor F_1 for Unit Cell Tube Array	43
III. Correction Factor F_2 for Number of Tube-side Passes.....	47
IV. Correction Factor F_3 for Various Tube Bundle Layouts.....	49
V. Correction Factor F_f for Low-finned Tubes.....	51
VI. Typical Overall Heat Transfer Coefficients for Shell and Tube Heat Exchangers	75
VII. Typical Film Heat Transfer Coefficients and Fouling Factors for Shell and Tube Heat Exchangers	78
VIII. Characteristics of Tubing	91
IX. Dimensions of Finned Tubes	92
X. Tube Count for Fixed Tubesheet Heat Exchangers	96
XI. Tube Count for Split Ring Floating Head Heat Exchangers	97
XII. Tube Count for U-Tube Heat Exchangers.....	98
XIII. Tube Count for PTFH Heat Exchangers (1000 KPa Pressure).....	99
XIV. Tube Count for PTFH Heat Exchangers (2000 KPa Pressure).....	100
XV. Correction Factor F_2 for Fixed Tubesheet Heat Exchangers	104
XVI. Correction Factor F_2 for SRFH Heat Exchangers	106
XVII. Correction Factor F_2 for U-Tube Heat Exchangers	106

Table	Page
XVIII. Correction Factor F_2 for PTFH Heat Exchangers (1000 KPa Pressure).....	108
XIX. Correction Factor F_2 for PTFH Heat Exchangers (2000 KPa Pressure)	108
XIX. Factor F_3 for SRFH Heat Exchangers	111
XX. Factor F_3 for U-Tube Heat Exchangers	111
XXI. Factor F_3 for PTFH Heat Exchangers (1000 KPa Pressure)	113
XXII. Factor F_3 for PTFH Heat Exchangers (2000 KPa Pressure).....	113
XXIII. Packing Factor for Fixed Tubesheet Heat Exchangers	116
XXIV. Packing factor for U-Tube Heat Exchangers	117
XXV. Packing Factor for SRFH Heat Exchangers.....	118
XXVI. Packing Factor for PTFH Heat Exchangers (1000 KPa Pressure).....	119
XXVII. Packing Factor for PTFH Heat Exchangers (2000 KPa Pressure).....	120

LIST OF FIGURES

Figure	Page
1. TEMA Designation of Front End, Shell, and Rear End Types of Shell and Tube Heat Exchangers	4
2. Fixed Tubesheet Design with Expansion Joint.....	5
3. U-Tube Design.....	6
4. Split-ring Floating Head Design	7
5. Pull-through Floating Head Design	8
6. Outside Packed Lantern-ring Design	8
7. Outside Packed Stuffing Box Design	9
8. Types of Commercial Finned Tubing.....	14
9. Cross-section of Fluid-to-fluid Heat Transfer Through a Tube Wall	18
10. Block Diagram of a Single Pass Shell and Tube Heat Exchanger with Counter-current Flow of Fluids	27
11. Temperature Profiles in a Single Pass Shell and Tube Heat Exchanger with Counter-current Flow of Fluids	27
12. Block Diagram of a Single Pass Shell and Tube Heat Exchanger with Co-current Flow of Fluids.....	28
13. Temperature Profiles in a Single Pass Shell and Tube Heat Exchanger with Co-current Flow of Fluids.....	28
14. Temperature Profiles for a Single Pass, Counter-current Flow, Shell and Tube Heat Exchanger with Varying Fluid Properties.....	30
15. 1-2 Shell and Tube Heat Exchanger	31
16. Temperature Profile in a 1-2 Shell and Tube Heat Exchanger	31

Figure	Page
17. LMTD Correction Factor for a 1-n Shell and Tube Heat Exchanger.....	33
18. Estimation of Number of Shells Required in Series	35
19. Equivalent Area as a Function of Shell Inside Diameter and Effective Tube Length for 19.05 mm. OD Tubes on 23.81 mm. Equilateral Triangular Tube Layout, Fixed Tubesheet, One Tube-side Pass, Fully Tubed Shell.....	38
20. Dimensional Nomenclature Used for Type S/T Trufin Finned Tubes.....	50
21. Baffle Cut Angle	59
22. Unit Cell Array for Triangular Pitch Layout	101
23. Unit Cell Array for Square and Rotated Square Layouts.....	103
24. Correction Factor F_2 for Fixed Tubesheet Heat Exchangers.....	105
25. Correction Factor F_2 for SRFH Heat Exchangers	107
26. Correction Factor F_2 for U-Tube Heat Exchangers.....	107
27. Correction Factor F_2 for PTFH Heat Exchangers (1000 KPa Pressure)	109
28. Correction Factor F_2 for PTFH Heat Exchangers (2000 KPa Pressure)	109
29. Correction Factor F_3 for SRFH Heat Exchangers	112
30. Correction Factor F_3 for U-Tube Heat Exchangers.....	112
31. Correction Factor F_3 for PTFH Heat Exchangers (1000 KPa Pressure)	114
32. Correction Factor F_3 for PTFH Heat Exchangers (2000 KPa Pressure)	114
33 Packing Factor as a Function of the Diameter of Outer Tube Limit and Tube Pitch Layout for Various Exchanger Configurations	121
34 Baffle Spacing as a Function of Baffle Cut and Shell Inside Diameter for Fixed Tubesheet Heat Exchangers.....	124
35 Baffle Spacing as a Function of Baffle Cut and Shell Inside Diameter for U-Tube Heat Exchangers	124

Figure	Page
36 Baffle Spacing as a Function of Baffle Cut and Shell Inside Diameter for Split Ring Floating Head Exchangers.....	125
37 Baffle Spacing as a Function of Baffle Cut and Shell Inside Diameter for Pull-through Floating Head Heat Exchangers (1000 KPa Pressure)	126
38 Baffle Spacing as a Function of Baffle Cut and Shell Inside Diameter for Pull-through Floating Head Heat Exchangers (2000 KPa Pressure)	127
39 Baffle Spacing as a Function of Baffle Cut and Shell Inside Diameter for Fixed Tubesheet Heat Exchangers.....	128
40 Baffle Spacing as a Function of Baffle Cut and Shell Inside Diameter for Fixed Tubesheet Heat Exchangers.....	129

NOMENCLATURE

A	Area; A' "equivalent" area, ft ² or m ²
C _p	Specific heat at constant pressure, BTU/lb _m °F or KJ/kg K
D	Diameter of shell, in. or m
d	Diameter of tube, in. or mm
D _{otl}	Diameter of outer tube limit, in. or mm
d _r	Root diameter of finned tube, in. or mm
F ₁	Correction factor for unit cell tube array
F ₂	Correction factor for number of tube-side passes
F ₃	Correction factor for the shell construction/tube bundle layout type
F _f	Correction factor for finned tubes
F _T	Configuration correction factor on LMTD
g _c	Gravitational conversion constant, 4.17x10 ⁸ lb _m -ft/lb _f -hr ²
h _f	Height of fin for low finned tubes, in. or mm
k	Thermal conductivity, BTU/hr ft ² (°F/ft) or W/m ² (K/m)
L	Tube length, ft. or m
l _c	Baffle cut distance from baffle tip to shell inside diameter, in. or mm

LMTD	Logarithmic Mean Temperature Difference, °F or K
l_s	Central baffle spacing, in. or mm
l_{si}, l_{so}	Baffle spacing at inlet and exit sections, in. or mm
m	Mass flow rate, lb_m/hr or kg/s
MTD	Mean Temperature Difference, °F or K
PTFH	Pull-through Floating Head
p	Tube layout pitch, in. or mm
p_n	Tube layout pitch normal to the direction of flow, in. or mm
ΔP	Pressure drop, $lb_f/in.^2$ or Pa
q	Heat flux, $BTU/hr\ ft^2\ ^\circ F$ or $W/m^2\ K$
Q	Total heat duty, BTU/hr or W
Re	Reynolds number
R_{fi}, R_{fo}	Fouling resistance to heat transfer on tube-side and shell-side respectively, $hr\ ft^2\ ^\circ F/BTU$ or $m^2\ K/W$
S	Cross-sectional area of tube or pipe, ft^2 or m^2
S_m	Crossflow area at or near the centerline for one crossflow section, ft^2 or m^2
SRFH	Split Ring Floating Head
S_w	Area for flow through window, ft^2 or m^2
t	Temperature of cold fluid, °F or K
T	Temperature of hot fluid, °F or K
U	Overall heat transfer coefficient, $BTU/hr-ft^2-^\circ F$ or W/m^2-K
V	Velocity of fluid, ft/s or m/s
y_f	Fin thickness for low finned tubes, in. or mm

GREEK SYMBOLS

α	Individual film heat transfer coefficient, BTU/hr ft ² °F or W/m ² K
η	Efficiency

SUBSCRIPTS:

c	Cold fluid
f	Fin
h	Hot fluid
i	Inside a tube or pipe
l	Liquid phase
o	Outside a tube
s	Shell side
t	Tube side
T	Total
v	Vapor phase
w	Wall surface

CHAPTER I

SHELL AND TUBE HEAT EXCHANGERS

Introduction

The need for a design procedure to quickly estimate the size of a shell and tube heat exchanger arises in various situations. Most of these occur at the initial stages of a project. For any project at this stage, a critical factor to be considered is the economic feasibility. In this regard one has to determine the cost of major items of equipment. To do this an estimate of the size of the major equipment is required. A second reason for a quick estimate of the size of the equipment is for the preparation of a preliminary plant layout. This will give one a rough idea as to the amount of space that would be required for the plant and of the placement of the major components. To perform a detailed analysis to determine the size of all the heat exchangers in the plant at this stage would be an unnecessary, time consuming activity.

Computer programs are now available for the detailed design of heat exchangers for which numerous parameters have to be specified. These programs are written by specialized computer programmers and the exact contents are usually unknown to the design engineer who actually implements them. This can be dangerous in that an error in the program or in the input of data, if not detected at the early stages, can lead to errors that could prove expensive at a later stage. This makes it desirable for the design engineer to make a quick check of the computer design by hand and confirm the validity

of that design. This gives us a third reason to have an approximate design method with which one could quickly estimate the size of the shell and tube heat exchanger.

A fourth reason is related to the computer analysis and other detailed methods in that the quick method of estimation of the size of the shell and tube heat exchanger can give the input parameters for the computer programs. This would almost certainly speed up the detailed analysis as fewer iterations would be required to complete the design. The data from the preliminary method will also provide the variables for detailed hand rating procedures in the event this is required.

In any process plant, in layman's terms, there is a need to heat things up and cool things down. This can be successfully accomplished by the use of heat exchangers, the most commonly used ones being the shell and tube type. In these cases a lot of heat energy is either input into the system or released from it and much precious energy was and probably still is being wasted. Of late, research is being carried out in the field of effectively using this heat by a method called HENS (Heat Exchanger Network Synthesis), which was first studied by Linnhoff (1982). This has added a whole new dimension to the theory of heat exchangers and their importance in the process industry. In any process plant a large number of heat exchangers are in service which has a direct bearing on the equipment and operating cost of the plant. Again, a detailed analysis at this stage would be quite an unnecessary task requiring a lot of time and money, the two things usually not available in abundance.

Taking into account all the above factors, it is evident that a quick manual estimate of the size of the shell and tube heat exchangers will be a very useful tool for successful design and running of the plant.

The present version of this method has been in existence for the past quite a few years (at least 20) and has worked reasonably well. However, the method has some deficiencies and also some inconsistencies that have to be dealt with. Also, in recent years, emphasis has been laid on the system of units used. Until a few years ago, the U.S.

Customary system was used. The present thesis incorporates the S.I. units into the design method.

Shell and Tube Heat Exchangers .

There are several types of heat exchangers used in the Chemical Process Industry (CPI), the most common type being the shell and tube heat exchanger. This thesis deals exclusively with this type.

Shell and tube heat exchangers are composed of four principal sub-assemblies:

- 1) Front end
- 2) Rear end
- 3) Tube bundle
- 4) Shell

These sub-assemblies can be arranged in different combinations. These sub-assemblies are of various types, which are designated by alphabetic characters. These are shown in figure 1.1 (TEMA, 1988). The resulting exchanger is designated by a three-letter combination characterizing, in order, the stationary front end, the shell, and the rear end, for example, AES.

There are three principal types of shell and tube heat exchangers.

A) Fixed-Tubesheet Design:

The fixed-tubesheet exchanger is the most common, and typically has one of the lowest capital costs per m² of heat transfer area, the lowest being that of the U-tube type. As shown in figure 1.2, this design employs straight tubes secured at both ends into tubesheets that are either welded to the shell or attached by flanged joints. To account for any thermal expansion, i.e., the expansion caused in the tubes and the shell due to

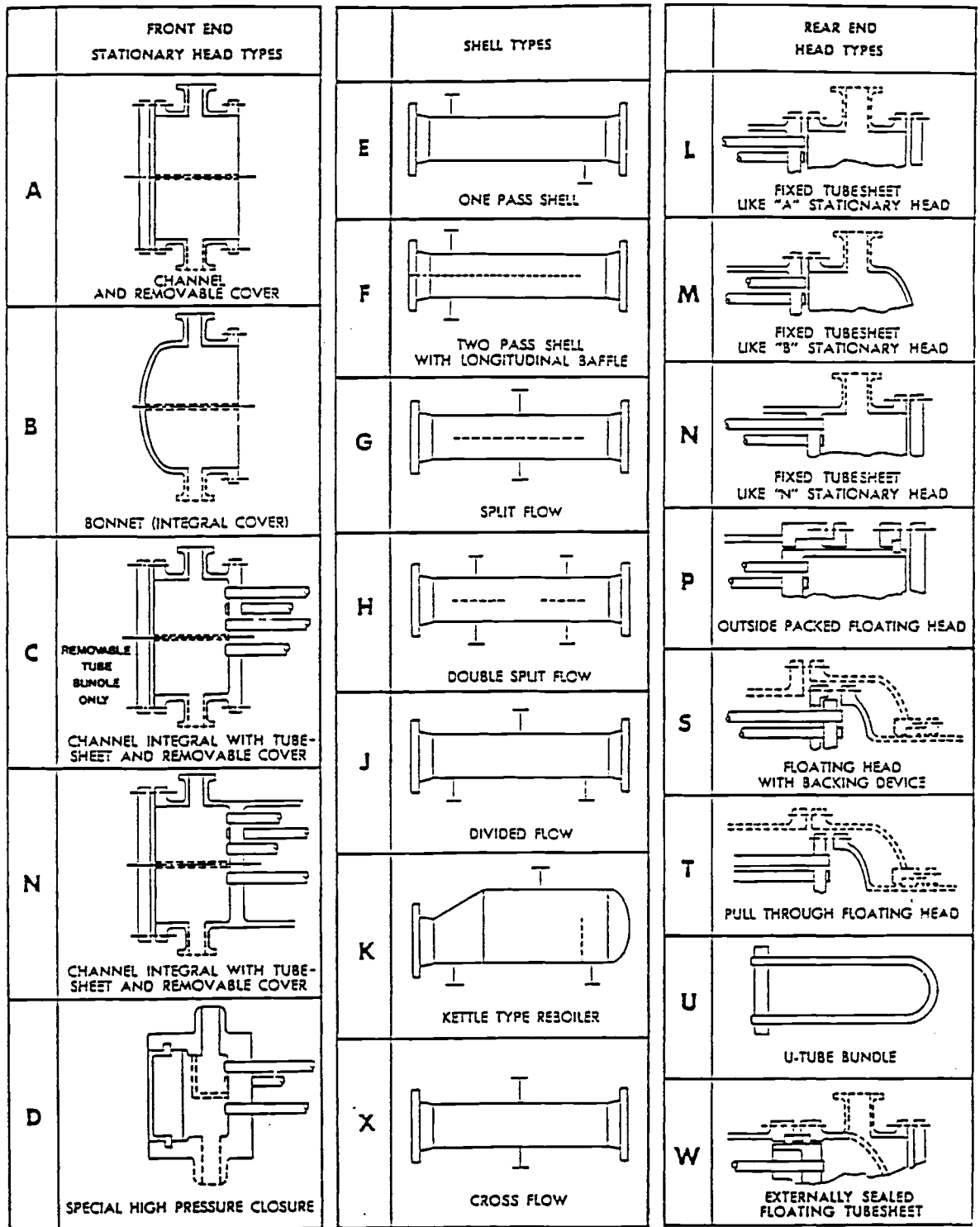

Figure 1.1 TEMA Designation of Front End, Shell, and Rear End Types of Shell and Tube Heat Exchangers (TEMA, 1988).

different temperatures, an expansion joint such as a bellows may be incorporated in the shell, allowing it to expand or contract. Because there are neither flanges nor packed or gasketed joints inside the shell, potential leak points are eliminated, making the design suitable for higher pressure or potentially lethal service. However, since the tube bundle cannot be removed, the shell-side of the exchanger can be cleaned only by chemical means. In this configuration, any practical number of tube-side passes, odd or even, are possible. For multi-pass arrangement, partitions are built into both the heads. Common TEMA designations are BEM, AEM, and NEN.

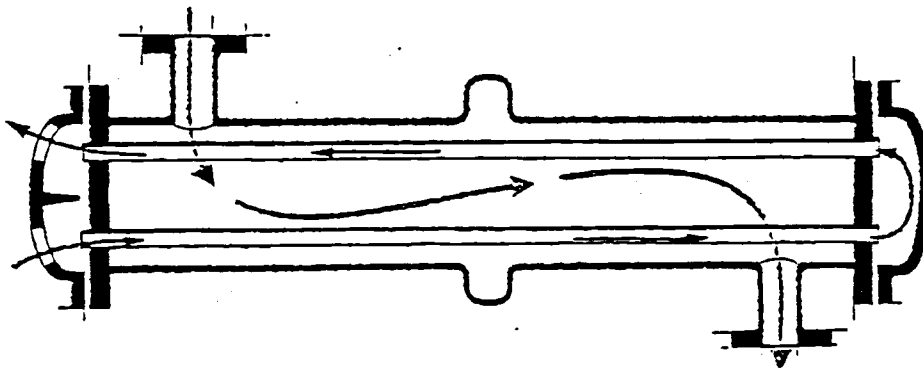

Figure 1.2 Fixed Tubesheet Design with Expansion Joint (The Patterson-Kelley Co., 1959).

B) U-tube Design:

In this type of design, figure 1.3, the differential expansion is taken care of by the U-shape of the tubes. As the name implies, the tubes have a “hairpin” shape, with both ends of the tubes fastened to one tubesheet. This design allows each tube to expand and contract independently. The U-tube bundle can be withdrawn to provide access to the inside of the shell, and to the outside of the tubes. However, mechanical cleaning of the inside of the tubes is not possible as there is no way to physically access the U-bend region inside each tube, so chemical methods are required for tube-side maintenance. In this type of exchanger, a single pass is not possible because the fluid must traverse the length of the tube bundle at least twice. Any practical even number of passes can be

obtained by building partition plates in the front head. Common TEMA designations are BEU and AEU.

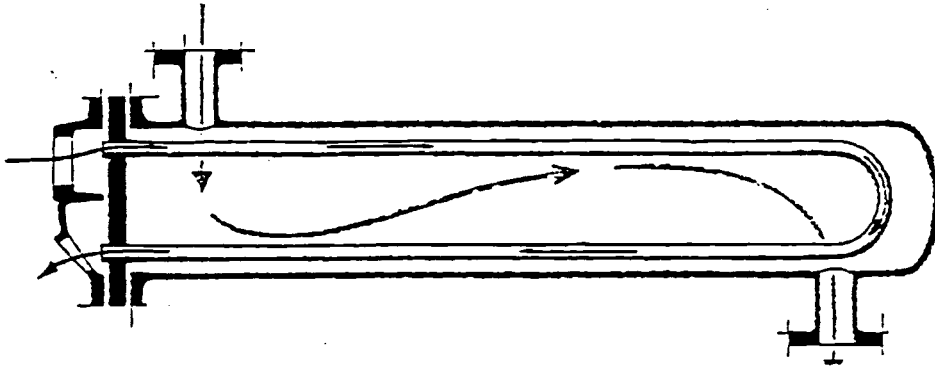

Figure 1.3 U-Tube Design (The Patterson-Kelley Co., 1959).

C) Floating Head Designs:

This type meets the expansion problem by having one stationary tubesheet and one free to move or “float” back and forth as the tubes expand and contract under the influence of temperature changes. Since the entire tube bundle is removable, maintenance is easy and inexpensive. Floating head designs are generally not used with odd number of tube-side passes as it poses severe sealing problems. This is due to the fact that with odd number of passes, arrangements have to be made to account for the nozzle on the floating head. This could be achieved by providing a packed joint on the floating cover. This does not guarantee a leak-proof joint and hence, is generally avoided. There are four common variations of this design:

i) **Split-Ring Floating Head Design:** In this type (figure 1.4), to separate the shell- and tube-side fluids at the floating head end, the tube-side of the floating tubesheet is fitted with a flanged, gasketed cover at its periphery which is held in position by bolting it to a split backing ring on the other side of the tubesheet. The backing ring is made in two halves and runs around the periphery of the tube bundle. The complete floating head assembly (flange, cover, tubesheet and backing ring) is located beyond the

main shell cover of larger diameter. Service and maintenance costs are higher than the pull-through type since the shell cover, split-ring and floating head cover must be removed before the tube bundle can be removed. Any practical even number of passes is possible. Common TEMA designations are AES and BES.

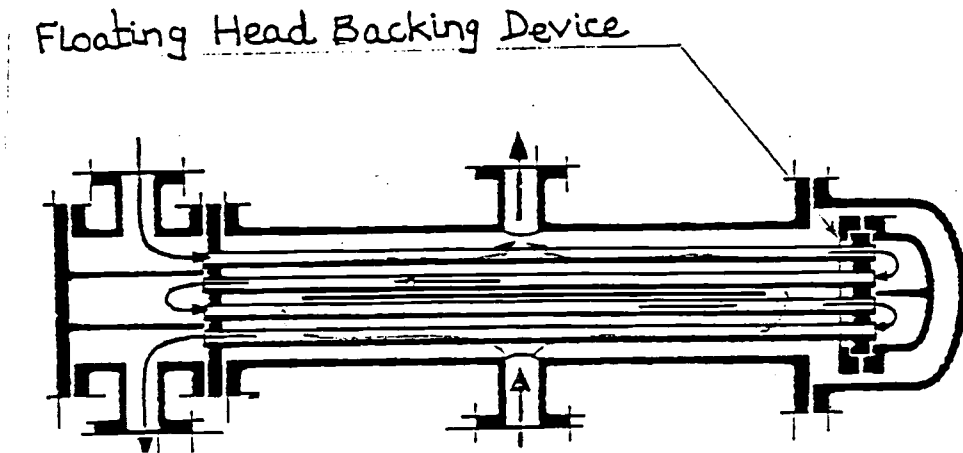

Figure 1.4 Split-Ring Floating Head Design (The Patterson-Kelley Co., 1959)

ii) **Pull-through Floating Head Design:** Here (figure 1.5), a separate head or cover is placed over the floating tubesheet within the head on the shell side, i.e., the diameter of the tubesheet is less than the shell inside diameter. The floating head is internally gasketed to prevent leakage between the tube and shell sides. The split backing ring is not required in this case and the floating tubesheet diameter must be increased to match the outside diameter of the floating-head flange. As a result, the shell diameter becomes approximately the same as that of the enlarged shell cover of the split backing ring type to accommodate the same number of tubes. Internal pressure has a significant effect in this case; the flange diameter increases as the pressure increases so that the area available for tubes in a given shell diameter is reduced. This configuration is ideal for applications that require frequent cleaning; however, it is among the most expensive designs. With this type, only an even number of tube-side passes is possible. For single pass operation, however, a packed joint must be installed on the shell cover, which is rarely done. The packed joint for odd number of passes has to be provided to account for

main shell cover of larger diameter. Service and maintenance costs are higher than the pull-through type since the shell cover, split-ring and floating head cover must be removed before the tube bundle can be removed. Any practical even number of passes is possible. Common TEMA designations are AES and BES.

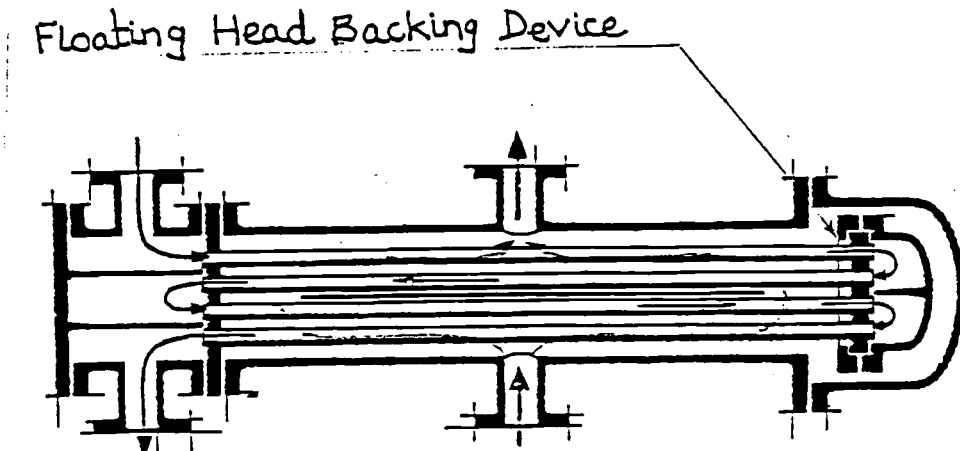

Figure 1.4 Split-Ring Floating Head Design (The Patterson-Kelley Co., 1959)

ii) **Pull-through Floating Head Design:** Here (figure 1.5), a separate head or cover is placed over the floating tubesheet within the head on the shell side, i.e., the diameter of the tubesheet is less than the shell inside diameter. The floating head is internally gasketed to prevent leakage between the tube and shell sides. The split backing ring is not required in this case and the floating tubesheet diameter must be increased to match the outside diameter of the floating-head flange. As a result, the shell diameter becomes approximately the same as that of the enlarged shell cover of the split backing ring type to accommodate the same number of tubes. Internal pressure has a significant effect in this case; the flange diameter increases as the pressure increases so that the area available for tubes in a given shell diameter is reduced. This configuration is ideal for applications that require frequent cleaning; however, it is among the most expensive designs. With this type, only an even number of tube-side passes is possible. For single pass operation, however, a packed joint must be installed on the shell cover, which is rarely done. The packed joint for odd number of passes has to be provided to account for

the floating tube-bundle and the possibility of the shell-side and tube-side mixing of fluids. Common TEMA designations are AET and BET.

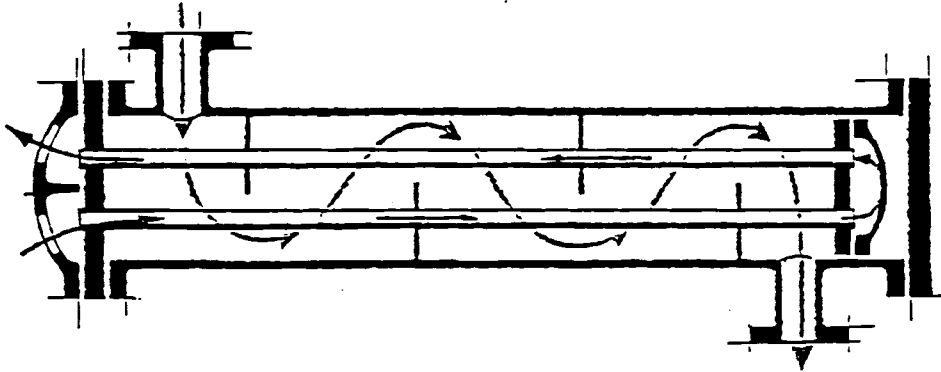

Figure 1.5 Pull-through Floating Head Design (The Patterson-Kelley Co., 1959)

iii) **Outside Packed Lantern-ring Design:** This employs a lantern ring around the floating tubesheet to seal the individual fluids as the floating tubesheet moves back and forth. As shown in figure 1.6, the lantern ring is packed on both sides and weep holes are provided so that any leakage is open to the atmosphere for ease of detection. This type can be made only single or two-pass on the tube side. Since these types of heat exchangers employ a packed joint, they are rarely used. Common TEMA designations are AEP and BEP.

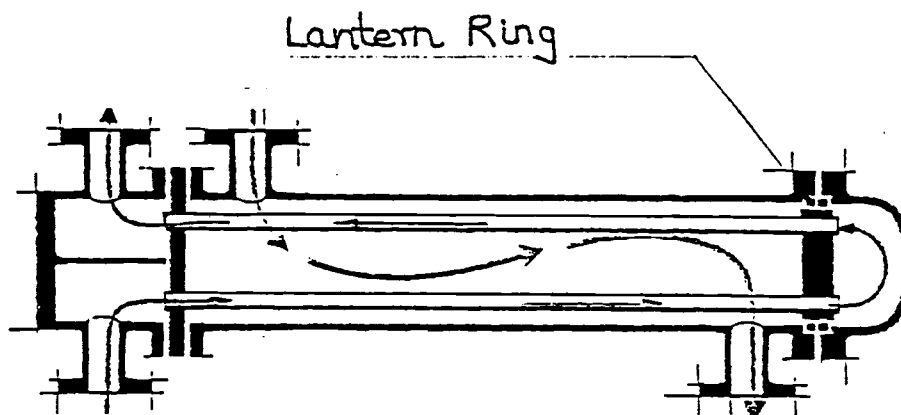

Figure 1.6 Outside Packed Lantern-ring Design (The Patterson-Kelley Co., 1959)

iv) **Outside Packed Stuffing Box Design**: This uses the outer skirt of the floating tubesheet as part of the floating head as shown below in figure 1.7. A packed stuffing box seals the shell-side fluid while allowing the floating head to move back and forth. Since the stuffing box is in contact with the shell-side fluid only, the possibility of mixing of the shell-side and tube-side fluids does not exist. This type has no practical tube pass limitations but poses severe sealing problems with any odd number of passes. Common TEMA designation is AJW and AEW.

Table 1.1 shows a comparison of the above discussed types of shell and tube heat exchangers for various conditions.

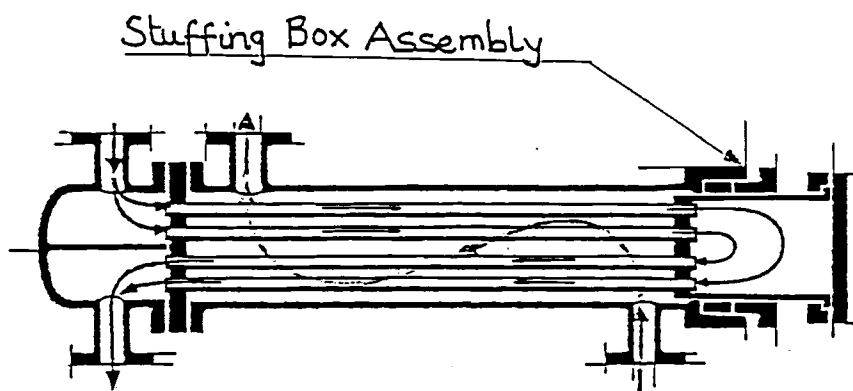

Figure 1.7 Outside Packed Stuffing Box Design (The Patterson-Kelley Co., 1959)

Components of Shell and Tube Heat Exchangers

Shell: Up to 24 inches in diameter, shells are usually seamless or welded pipes. Larger shells are usually made out of plates rolled to the specific diameter. TEMA Standards (TEMA, 1988) specify the minimum thickness to be used for the particular class of exchanger and the material of construction.

Tubes: These are the basic component of the shell and tube heat exchanger. They provide the heat transfer surface between one fluid flowing inside the tubes and another flowing across the outside. The tubes can either be plain (i.e., bare) or have an extended

Type of Design	"U"-Tube	Fixed Tubesheet	Floating Head Pull-Through Bundle	Floating Head Outside Packed Lantern-Ring	Floating Head Split Backing Ring	Floating Head Outside Packed Stuffing Box
Relative Cost Increases From (A) Least Expensive through (E) Most Expensive	A	B	C	C	D	E
Provision for Differential Expansion	individual tubes free to expand	expansion joint in shell	floating head	floating head	floating head	floating head
Removable Bundle	yes	no	yes	yes	yes	yes
Replacement Bundle Possible	yes	not practical	yes	yes	yes	yes
Individual Tubes Replaceable	only those in outside row	yes	yes	yes	yes	yes
Tube Interiors Cleanable	difficult to do mechanically can do chemically	yes. mechanically or chemically	yes. mechanically or chemically	yes. mechanically or chemically	yes. mechanically or chemically	yes. mechanically or chemically
Tube Exteriors With Triangular Pitch Cleanable	chemically only	chemically only	chemically only	chemically only	chemically only	chemically only
Tube Exteriors With Square Pitch Cleanable	yes. mechanically or chemically	chemically only	yes. mechanically or chemically	yes. mechanically or chemically	yes. mechanically or chemically	yes. mechanically or chemically
Double Tubesheet Feasible	yes	yes	no	no	no	yes
Number of Tube Passes	any practical even number possible	no practical limitations	no practical limitation (for single pass, floating head requires packed joint)	limited to single or 2 pass	no practical limitation (for single pass, floating head requires packed joint)	no practical limitation
Internal Gaskets Eliminated	yes	yes	no	yes	no	yes

Table 1.1 Features of Principal Shell and Tube Heat Exchanger Designs (The Patterson-Kelley Co., 1959).

surface. There are various types of extended surfaces in service, the most common type being finned tubes.

Tubesheets: The tubes are held in place by being inserted into the holes in the tubesheet and then rolled and/or welded. Tubesheets are in contact with both the shell-side and tube-side fluids and must withstand the pressure on both sides. Tubesheets also function as a partition between the two fluids, i.e., they do not allow the mixing of the two fluids.

Baffles: These are used on the shell side. Baffles are used primarily to support the tubes along the length of the heat exchanger. They also direct the flow of the shell-side fluid causing increased turbulence and higher heat transfer coefficients. The TEMA Standards (TEMA, 1988) specify the minimum baffle thickness and spacing for a particular class of heat exchanger.

Tie rods and spacers: Tie rods extend from one tubesheet to the last baffle. Their primary purpose is to hold the spacers. Spacers are small tubes of the appropriate length used to maintain the distance between adjacent baffles. In some cases tie rods are also placed in place of the tubes underneath the nozzles to perform as impingement plates.

Pass partition plates: These are used only when multiple passes on the tube-side are required. These plates are welded to the head.

Sealing strips: These are typically flat metallic strips either notched into or welded to the baffles. Their use is to minimize the bypass stream between the shell and the tube bundle. They are usually attached in pairs.

Impingement plates: These are plates placed directly under the inlet nozzle on the shell-side. Their purpose is to break up and divert the incoming jet of fluid from the nozzle, thus protecting the tubes from erosion and vibration. They are placed such that the area between the plate and the shell, called the escape area, is larger than the inlet nozzle area in order to reduce the velocity.

Selection Criteria

There are no strict rules that are followed for the selection of a particular type of shell and tube heat exchanger. In general, the following broad statements can be made:

- 1) The heat exchanger must satisfy the process requirements. This includes meeting the desired change in the thermal conditions of the process streams within the allowable pressure drops.
- 2) The heat exchanger must withstand the service conditions including mechanical and thermal stresses developed during installation and operation, corrosion and to some extent fouling.
- 3) The heat exchanger must be maintainable for the particular service conditions. This implies choosing a configuration that permits cleaning - tube-side and/or shell-side, as required - and replacement of tubes, gaskets and other components vulnerable to corrosion, erosion or fouling.
- 4) Cost of the heat exchanger. This is basically the initial equipment cost. In some cases a trade-off is required between higher initial cost of the equipment and the long term advantages for the selection of a particular configuration.

Finned Tube Heat Exchangers

The need for enhanced tube configuration arises from the fact that, for certain services in the industry, the heat transfer coefficients achieved are very low. This means that a large surface area will be required to perform the specified duty. This warrants the use of enhanced tube geometry for such an application. Virtually every heat exchanger is a potential candidate for enhanced heat transfer. However, each application must be tested to see if enhanced heat transfer “makes sense.” An enhanced surface geometry may be used for one of the following three objectives:

- 1) *Size Reduction*: For a constant rate of heat exchange, the exchanger length and/or diameter may be reduced. This will provide a smaller heat exchanger.
- 2) *Reduced Mean Temperature Difference*: For constant rate of heat exchange and tube length, the Mean Temperature Difference (MTD) may be reduced. This provides increased thermodynamic process efficiency and yields a savings of operating costs.
- 3) *Increased Heat Exchange*: For constant length of the exchanger and fixed fluid inlet temperatures, an increase in the rate of heat exchange results.
- 4) *Reduced Pumping Power for Fixed Heat Duty*: This is theoretically possible. However, this will typically require that the enhanced heat exchanger operate at a velocity smaller than that of the competing plain surface. This will require increased frontal area, which is normally not desired.

Enhanced surfaces can be used to provide any of the above mentioned performance improvements. How much improvement is obtained depends on the designer's objectives. The subject of enhanced heat transfer is dealt with in great detail by Webb (1987).

Low finned tubes are used extensively in conventional shell and tube heat exchangers. Such types of enhanced surfaces are used primarily for gas-gas or gas-liquid systems, and for condensing and vaporizing services. The choice of a finned-tube size and arrangement is governed by numerous factors such as the finned-tube diameter, fin height and thickness, number of fins per inch and the material of the fin and the bare tube. In the case of shell and tube exchangers, finned tubes used are almost always integral, i.e., fins and tube are the same metal. The geometry and the performance factors include the transverse and longitudinal pitch, the shell and the tube-side mass velocity, metal temperature of the fin tip, and the allowable pressure drops for the shell- and the tube-side. The first low-fin condenser tube was developed in 1940. The first, and still the most common one, has 19 fins/inch with a fin height of slightly less than 1/16 inch. The fins on a low-fin tube are radially extruded from a fairly thick walled tube in a lathe-like

finning machine. The resulting fins provide up to 5 times the outside surface area of a bare tube with the same nominal diameter. Figure 1.8 shows various types of finned tubes.

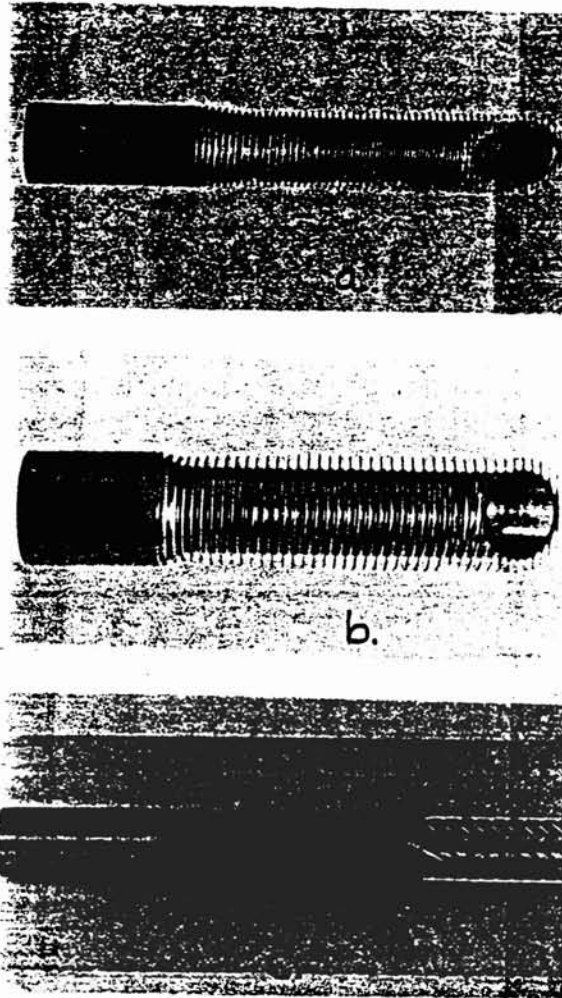

Figure 1.8 Types of Commercial Finned Tubing: (a) Wolverine Type S/T Trufin[®] Low Finned Tube With 19 Fins per In. (b) Wolverine Type S/T Trufin[®] Medium Finned Tube With 11 Fins per In.; (c) Wolverine Type Turbo-Chil[®] Finned Tube.

CHAPTER II

BASIC STRUCTURE OF THE DESIGN METHOD

Modes of Heat Transfer

There are three modes of heat transfer: Conduction, convection, and radiation. For engineering calculations, it is always convenient to consider the three modes separately and then combine the results into an overall solution.

Conduction:

In a solid body, the flow of heat is the result of a process in which kinetic energy is transferred from one molecule to another. This mode of heat transfer is called conduction. In liquids and gases the molecules are not confined to their locations, but move around and in this way transport energy. This process is still classified as conduction as long as no macroscopic movement can be detected. The fundamentals of heat conduction were established over a century ago with pioneering work by Biot and Fourier. The equation defining the rate of 1-D conduction heat transfer, first given by Biot (1804) and later solved by Fourier (c. 1824) for a number of complicated cases is

$$Q = -kA \frac{dT}{dx} \dots\dots\dots(2.1)$$

where Q = Rate of heat transfer in the x direction, BTU / hr or W

$\frac{dT}{dx}$ = Temperature gradient in the x direction at the point under consideration,

(^oF / ft) or (K / m)

A = Cross-sectional area perpendicular to the x direction, ft² or m²

k = Thermal conductivity of the solid,

BTU / hr ft² (^oF / ft) or W / m² (K / m)

Thermal conductivity is a characteristic of the material and is determined experimentally (Hutchinson, 1945).

For the case of shell and tube heat exchangers, we have to consider conduction through a cylindrical tube. The equation for conduction, on integration, becomes

$$Q = \frac{2\pi L k_w (T_i - T_o)}{\ln\left(\frac{r_o}{r_i}\right)} \dots\dots\dots(2.2)$$

where L = Length of the tube, ft or m

k_w = Thermal conductivity of the tube material,

BTU / hr ft² (^oF / ft) or W / m² (K / m)

r_o, r_i = Outside and inside radii of the tube, respectively, ft or m

T_o, T_i = Outside and inside wall surface temperatures, respectively, ^oF or K

Convection:

Heat transfer by convection occurs due to the motion of a fluid, the heat being carried as internal energy. This mode of heat transfer takes place when the fluid flow is

either laminar or turbulent. Convective heat exchange is enhanced by the fluctuating motions, called eddies, in the turbulent stream. This is not the case with laminar flows and hence the heat transfer by convection in turbulent flow is considerably higher than in laminar flow.

Radiation:

Radiation is the transfer of energy through space by means of electromagnetic waves. Radiation heat transfer, as opposed to conduction and convection, does not require the presence of a medium to convey the heat from the source to the receiver, i.e., heat can be transmitted by radiation across an absolute vacuum. Radiation heat transfer can normally be ignored unless temperatures are very high, as in flames, combustion systems, or solids heated to red heat. It is also very important in low temperature (cryogenic) systems where the cold bodies are isolated in high-vacuum enclosures to eliminate convection and conduction effects. Such systems are not considered in this thesis.

Film Heat Transfer Coefficients

For many convective heat transfer processes, it is found that the local heat flux is approximately proportional to the temperature difference between the wall and the bulk of the fluid, i.e.,

$$\frac{Q}{A} \propto (T_b - T_w) \dots\dots\dots(2.3)$$

or

$$\frac{Q}{A} = \alpha (T_b - T_w) \dots\dots\dots(2.4)$$

The constant of proportionality, ‘ α ’, is called the “film coefficient of heat transfer,” and has the units BTU/hr ft² °F or W/m² K. The value of α depends on the geometry of the system, the physical properties of the fluid, and the velocity of flow.

The Overall Heat Transfer Coefficient

The various processes described above can be described as resistances to heat transfer. Hence,

For conduction through a cylindrical wall:

$$R_{\text{cond}} = \frac{\ln\left(\frac{r_o}{r_i}\right)}{2\pi Lk_w} \dots\dots\dots(2.5)$$

For convection:

$$R_{\text{conv}} = \frac{1}{\alpha A} \dots\dots\dots(2.6)$$

In a typical shell and tube heat exchanger with no fouling and no fins, these resistances act in series in the following way (refer to figure 2.1):

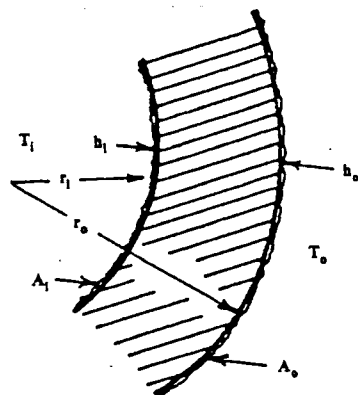

Figure 2.1 Cross-section of Fluid-to-fluid Heat Transfer Through a Tube Wall (Bell, 1993).

- 1) Convective resistance from the bulk of the fluid inside the tube to the wall of the tube,
- 2) Conductive resistance through the wall of the tube and
- 3) Convective resistance from the outer surface of the tube to the bulk of the fluid flowing across the tube.

In most heat exchangers in actual service, after some period of use, the amount of heat transferred for a given temperature difference decreases. This occurs because deposits accumulate on the heat exchange surface and interpose an additional barrier to heat flow. These deposits include sedimentation from dirty water, scale, organic growth, etc.. Heat transfer across these films is predominantly by conduction, but the thickness of the deposit or its thermal conductivity are seldom known for the designer to treat it as an individual conduction problem. The deposits are generally termed “fouling”. Based on past experience of manufacturers and users, tables of “fouling factors” (typical units of $\text{hr}\cdot\text{ft}^2\cdot\text{°F}/\text{BTU}$ or $\text{m}^2\cdot\text{K}/\text{W}$) have been prepared by TEMA (TEMA, 1988) and are presented in Appendix A. The reciprocals of the fouling factors are the heat transfer coefficients for the fouling material. These values cannot be determined directly by calculations, but are established experimentally and more so with experience. Fouling factors or fouling resistances are a measure of the resistance to heat transfer due to the presence of the fouling.

Extended surfaces or fins are frequently employed in shell and tube heat exchangers. Fins will be beneficial if they are applied to the fluid stream having the dominant thermal resistance (lower heat transfer coefficient). The fins provide reduced thermal resistance for this stream by providing increased surface area. The heat transfer coefficient on the extended surfaces may be either higher or lower than that which would occur on the unfinned/plain surface. Because of the temperature gradient in the fin material over its length, the amount of heat transferred by the fin is less than the amount that would be transferred by a fin of infinite thermal conductivity. Thus, the heat

conductance of a finned surface (αA) must be multiplied by a fin efficiency factor to account for the temperature gradient in the fin.

The fin efficiency, η_f , is defined as the ratio of the actual heat transfer from the fin to that which would occur if the entire fin were at its base temperature. The efficiency of the fin is a function of its cross-sectional shape, its length, and the geometry of the base surface. Appendix D gives the dimensions of typical finned tubes. Fin efficiency equations for a number of specialized fin geometries are discussed in detail by Kern and Kraus (1972) and Bell and Mueller (1984).

For most shell and tube heat exchanger applications, this efficiency can be calculated as follows (Bell & Mueller, 1984):

$$\eta_f = \frac{1}{1 + \frac{m^2}{3} \sqrt{\frac{d_f}{d_r}}} \dots\dots\dots(2.7)$$

where $m = h_f \sqrt{\frac{2}{\left(\frac{1}{\alpha_o} + R_{f_o}\right) k_f y_f}} \dots\dots\dots(2.8)$

d_f = Outside diameter of finned tube, ft or m

d_r = Root diameter of finned tube, ft or m

h_f = Fin height, ft or m

y_f = Fin thickness, ft or m

k_f = Thermal conductivity of fin material, BTU / hr ft² (°F / ft) or W / m² (K / m)

An inspection of Eqs. (2.7) and (2.8) indicates that the fin efficiency is higher for the better-conducting fin materials, and higher as the outside heat transfer coefficient becomes lower. Finned tubes are not generally used in applications where the fin

efficiency is lower than 0.65. For estimation purposes, the following simple guidelines could be followed:

- 1) The higher the thermal conductivity of the fin material, the higher the fin efficiency.
- 2) The smaller the fin height, the higher the fin efficiency.
- 3) The lower the outside heat transfer coefficient, the higher the fin efficiency.

For most finned-tube applications, over normal operating ranges, the efficiency lies between 0.9 and 1.0.

The heat flow can be considered to occur as a consequence of a driving force through a resistance. In this case, the driving force is the overall temperature difference and the resistance is the sum of all the above mentioned thermal resistances. The equation for the heat duty then becomes

$$Q = \frac{T - t}{\frac{1}{\alpha_i A_i} + \frac{R_{fi}}{A_i} + \frac{\ln\left(\frac{r_o}{r_i}\right)}{2\pi L k_w} + \frac{R_{fo}}{A_o} + \frac{R_{fin}}{A_o} + \frac{1}{\alpha_o A_o}} \dots\dots\dots(2.9)$$

where R_{fi} , R_{fo} = Resistance due to fouling on the inner and outer surface of the tube

respectively, $hr - ft^2 - ^\circ F / BTU$ or $m^2 - K / W$

R_{fin} = Fin resistance, $hr - ft^2 - ^\circ F / BTU$ or $m^2 - K / W$

k_w = Thermal conductivity of the tube material,

$BTU / hr - ft^2 - (^{\circ}F / ft)$ or $W / m^2 - (K / m)$

α_i , α_o = Film coefficients for inside and outside the tube respectively,

$BTU / hr - ft^2 - ^\circ F$ or $W / m^2 - K$

A_i , A_o = Inside and outside surface areas of the clean tubes

independent of fouling, ft^2 or m^2

In Equation (2.9), the temperatures T and t are the bulk fluid temperatures at a given “point” in the heat exchanger and Q , A_o , and A_i are associated with that point. The fouling is assumed to have negligible thickness and hence r_o , r_i , A_o , and A_i are those of the clean tube and independent of the buildup of fouling (refer to figure 2.1). Hence the values determined using the above equation are the “local values” corresponding to the “local point” in the heat exchanger.

The fin resistance term can be evaluated using the equation (Bell & Mueller, 1984)

$$R_{fin} = \left\{ \frac{1 - \eta_f}{\frac{A_{root}}{A_{fin}} + \eta_f} \right\} \left\{ \frac{1}{\alpha_o} + R_{f_o} \right\} \dots\dots\dots(2.10)$$

where A_{root} = Heat transfer area of the root portions between the fins, ft^2 or m^2

A_{fin} = Heat transfer area of all the fins on the tube, ft^2 or m^2

We can now define an ‘overall’ heat transfer coefficient U^* based on any reference area, A^* as

$$Q = U^* A^* (T - t) \dots\dots\dots(2.11)$$

where U^* = Overall heat transfer coefficient based on area A^* , $BTU / hr ft^2 ^\circ F$ or $W / m^2 K$

A^* = Reference area, ft^2 or m^2

Comparison of equations (2.9) and (2.11) gives

$$U^* = \frac{1}{\frac{A^*}{\alpha_i A_i} + \frac{R_{fi} A^*}{A_i} + \frac{A^* \ln\left(\frac{r_o}{r_i}\right)}{2\pi L k_w} + \frac{R_{fo} A^*}{A_o} + \frac{R_{fin} A^*}{A_o} + \frac{A^*}{\alpha_o A_o}} \dots\dots\dots(2.12)$$

The reference area can be chosen as any convenient area. This area need not be any area associated with the heat exchanger itself, but it should be one that is completely defined. In most cases, but not necessarily, this area is chosen to be the outside area of all the tubes in the heat exchanger, A_o . In this case,

$$U^* = U_o$$

and

$$U_o = \frac{1}{\frac{A_o}{\alpha_i A_i} + \frac{R_{fi} A_o}{A_i} + \frac{A_o \ln\left(\frac{r_o}{r_i}\right)}{2\pi L k_w} + R_{fo} + R_{fin} + \frac{1}{\alpha_o}} \dots\dots\dots(2.13)$$

and

$$Q = U_o A_o (T - t) \dots\dots\dots(2.14)$$

The overall heat transfer coefficient can also be written in terms of the fin efficiency instead of the fin resistance and the wall resistance term can be written using arithmetic mean instead of the logarithmic mean. Equation (2.13) then becomes:

$$U_o = \frac{1}{\frac{A_o}{\alpha_i A_i} + \frac{R_{fi} A_o}{A_i} + \frac{A_o \Delta x}{k_w A_m} + \frac{R_{fo}}{\eta_f} + \frac{1}{\eta_f \alpha_o}} \dots\dots\dots(2.15)$$

In the above equation, the wall conduction term has been written in terms of the arithmetic mean area and is evaluated for that portion of the tube wall that lies between

the inside diameter and the root diameter, i.e., exclusive of the fins. The term Δx refers to the wall thickness of the tube.

Typical values of the overall heat transfer coefficient can be found tabulated in various references (Bell, 1993; Kern, 1950; McKetta, 1992; Bell, 1983) and are presented in Appendix A, Table A.1 (Bell, 1993). This procedure can be highly inaccurate because the tabulated values generally include the entire range encountered in practice. A better procedure to estimate U_o is to estimate the values of the individual film coefficients characteristic of the specific service; typical values are given in Appendix A, Table A.2. The fouling factors are estimated either from the problem specification, personal experience, or typical values for the fluid and service (refer to Appendix A, Table A.2). For the case of finned tubes being employed, the fin efficiency is also estimated. The overall heat transfer coefficient is then estimated by using either Equation (2.13) or (2.15).

Basic Design Equation

Constant temperature difference, $(T - t)$, was assumed in the above discussion. In most exchanger applications, this is not true. One or both of the stream temperatures change along the length of the exchanger. Taking this factor into consideration, the design equation (2.11) is written in the differential form as:

$$dA^* = \frac{dQ}{U^*(T-t)} \dots\dots\dots(2.16)$$

This equation is then integrated over the entire heat duty of the exchanger. Hence,

$$A^* = \int_0^{Q_T} \frac{dQ}{U^*(T-t)} \dots\dots\dots(2.17)$$

This is the basic heat exchanger design equation. The required heat transfer area can then be calculated by plotting Q vs. $\frac{1}{U^*(T-t)}$ and evaluating the area under the curve or by using any of the available numerical methods.

Although the above mentioned method can be used for any case, it is desirable to have an easier method without a great loss in accuracy. This can be achieved by making certain simplifying assumptions. One set of assumptions that is reasonably valid for a wide range of cases and leads to a very useful result is the following (Bell & Mueller, 1984; Bowman, Mueller, & Nagle, 1940; Kern, 1950):

- 1) All elements of a given stream have the same thermal history. This simply means that all elements of a given stream that enter an exchanger follow paths through the exchanger that have the same heat transfer characteristics and have the same exposure to heat transfer surface.
- 2) The heat exchanger is at steady state.
- 3) Each stream has a constant specific heat.
- 4) The overall heat transfer coefficient is constant.
- 5) There are no heat losses from the exchanger.
- 6) There is no longitudinal heat transfer in the exchanger.
- 7) The flow is either entirely co-current or entirely counter-current.

Once these assumptions are made, the heat transfer area can be calculated directly for the case of co-current or counter-current flow using the equation (Bell & Mueller, 1984):

$$A^* = \frac{Q_T}{U^*(MTD)} \dots\dots\dots(2.18)$$

where MTD = Mean Temperature Difference, °F or K

The equations for MTD and the case where the seventh assumption is violated is dealt with in detail at a later stage.

Calculation of the Total Heat Duty, Q_T

For the case of single phase sensible heat transfer

$$Q_T = m_h C_{p_h} (T_1 - T_2) = m_c C_{p_c} (t_2 - t_1) \dots\dots\dots(2.19)$$

where m_h = Mass flow rate of the hot fluid, lb_m / hr or kg / s

m_c = Mass flow rate of cold fluid, lb_m / hr or kg / s

T_1, T_2 = Inlet and exit temperatures of the hot fluid, respectively, °F or K

t_1, t_2 = Inlet and exit temperatures of the cold fluid, respectively, °F or K

C_{p_h}, C_{p_c} = Specific heats of the hot and cold fluid respectively,

BTU / lb_m - °F or kJ / kg - K

Logarithmic Mean Temperature Difference

In the general heat transfer equation (2.17), the temperature difference term ΔT , the local (at any given point in the heat exchanger) temperature difference between the hot and the cold streams, cannot be used for the entire heat exchanger. After making the simplifying assumptions, equation (2.18) can be used to calculate the heat transfer area. For the case of pure co-current or counter-current flows, analytical evaluation of the design integral of equation (2.17) can be carried out, leading to different forms of the LMTD. The MTD concept is valid for many other flow configurations as will be seen later. The procedure to calculate the MTD can be found in numerous references (Bell, 1993; Bowman, et al., 1940; Jaw, 1964; Kern, 1950).

a) Counter-current flow of fluids (Refer to figure 2.2)

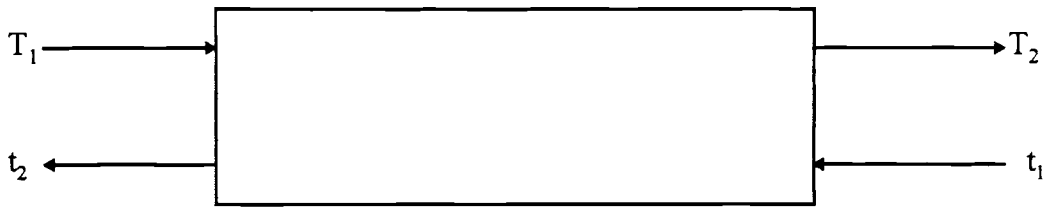

Figure 2.2 Block Diagram of a Single Pass Shell and Tube Heat Exchanger with Counter-current Flow of Fluids.

Consider the cooling of a fluid which enters at temperature T_1 and exits at T_2 . This cooling is accomplished by a fluid entering at temperature t_1 and exiting at t_2 . The temperature profiles along the length of the tube are given in figure 2.3.

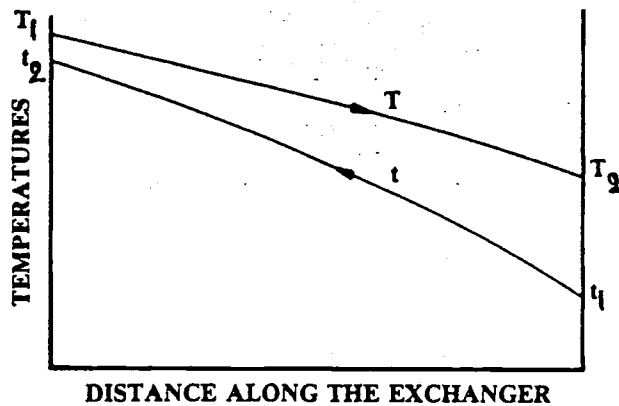

Figure 2.3 Temperature Profiles in a Single Pass Shell and Tube Heat Exchanger with Counter-current Flow of Fluids.

The MTD for this case is then calculated as

$$(\text{LMTD})_{\text{counter-current}} = \frac{(T_1 - t_2) - (T_2 - t_1)}{\ln \left\{ \frac{(T_1 - t_2)}{(T_2 - t_1)} \right\}} \dots\dots\dots(2.21)$$

b) Co-current/Parallel flow of fluids (Refer to figure 2.4)

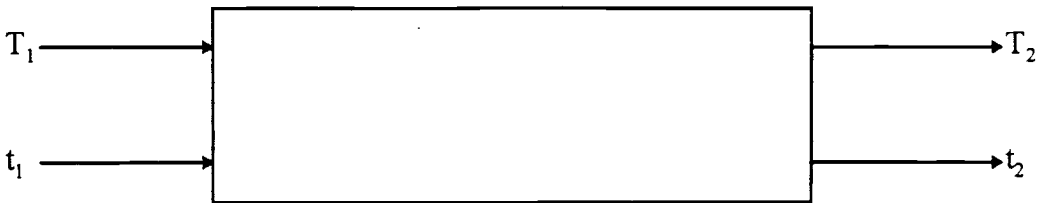

Figure 2.4 Block Diagram of a Single Pass Shell and Tube Heat Exchanger with Co-current or Parallel Flow of Fluids.

The same nomenclature is used for this case as the previous one. The temperature profiles are as shown in figure 2.5.

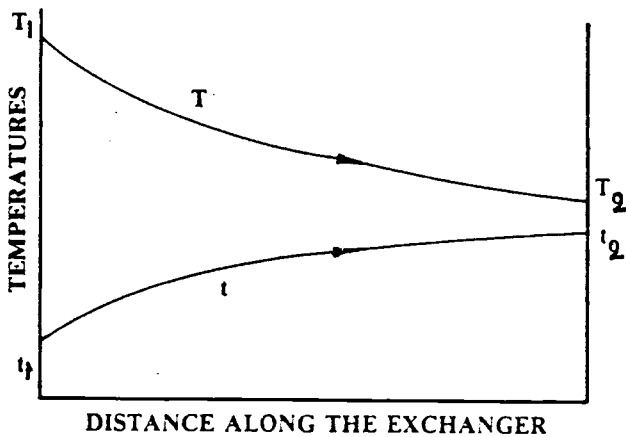

Figure 2.5 Temperature Profiles in a Single Pass Shell and Tube Heat Exchanger with Co-current or Parallel Flow of Fluids.

The MTD for this case is calculated by the equation:

$$(\text{LMTD})_{\text{co-current}} = \frac{(T_1 - t_1) - (T_2 - t_2)}{\ln \left\{ \frac{(T_1 - t_1)}{(T_2 - t_2)} \right\}} \dots\dots\dots(2.22)$$

The definitions of MTD's given in equations (2.20) and (2.21) are the logarithmic means of the terminal temperature differences in each case. Hence, for the case of pure co-current and counter-current flows, the MTD is referred to as the "Logarithmic Mean Temperature Difference", abbreviated as LMTD.

For some cases, the LMTD can be reasonably approximated by the arithmetic mean temperature difference, AMTD. Hence,

$$\text{AMTD} = \frac{(T_1 - t_2) + (T_2 - t_1)}{2} \dots\dots\dots(2.23)$$

The LMTD is always equal to or less than the AMTD. The difference between LMTD and AMTD increases with decreasing ratio of the smaller terminal temperature difference to the larger.

When the temperature difference varies greatly between the hot and cold terminals, large changes in the physical properties of the fluids may occur. To some extent changes in these properties can be compensated for by the application of the "Caloric" temperature concept. With it an "overall" coefficient is calculated for each end of the heat exchanger using equation (2.13) and incorporated into the general heat transfer equation as (Colburn, 1933):

$$Q = A \frac{U_2 \Delta T_1 - U_1 \Delta T_2}{\ln \left\{ \frac{U_2 \Delta T_1}{U_1 \Delta T_2} \right\}} \dots\dots\dots(2.24)$$

where U_1, U_2 = Overall heat transfer coefficients for each end of the heat exchanger,

BTU / hr ft² °F or W / m² K

$\Delta T_1, \Delta T_2$ = Corresponding temperature difference between the hot and the

cold streams at each end of the heat exchanger, °F or K

A possible temperature profile is shown in figure 2.6. In this case, the term overall temperature difference loses its meaning.

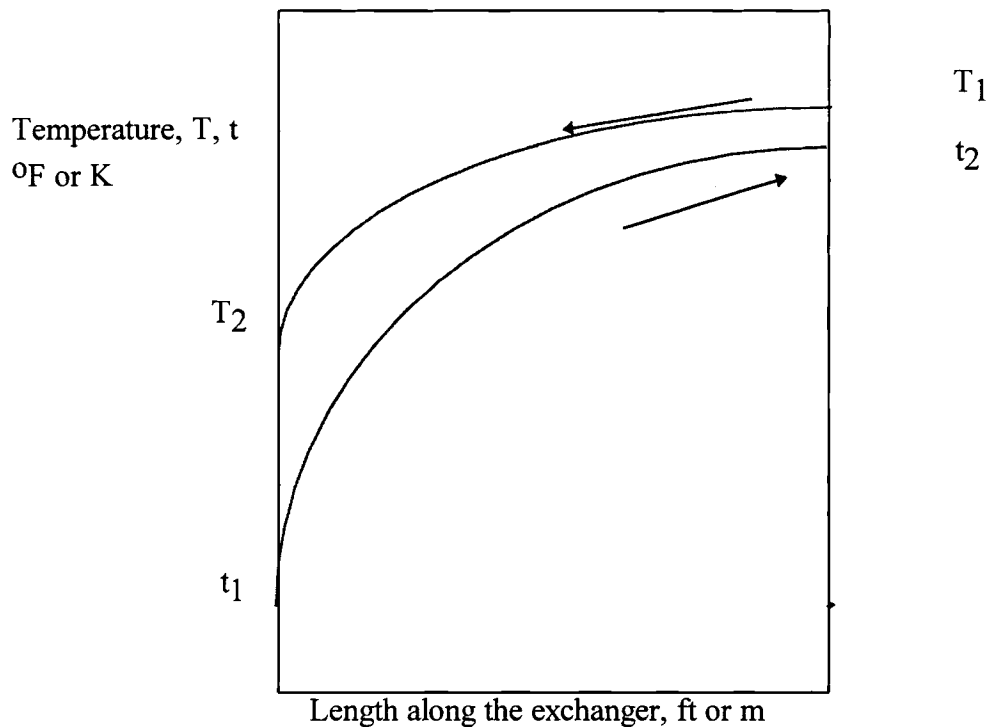

Figure 2.6 Temperature Profiles for a Single Pass, Counter-current flow, Shell and Tube Heat Exchanger with Varying Fluid Properties.

Mean Temperature Difference (MTD)

In the equations given above, true parallel or counter-current flow is assumed.

While this assumption usually works quite well for single pass exchangers, it is not true for multi-pass ones. For example, consider the 1-2 shell and tube heat exchanger shown

in figure 2.7, i.e., one shell side pass and two tube side passes. The corresponding temperature profile is shown in figure 2.8.

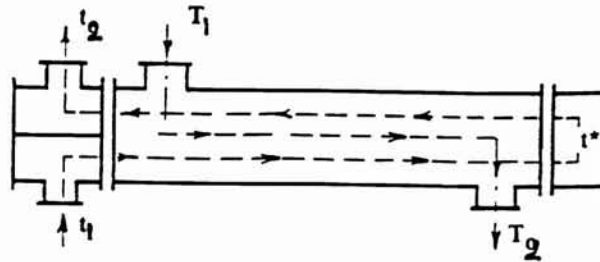

Figure 2.7 1-2 Shell and Tube Heat Exchanger (Bell, 1993).

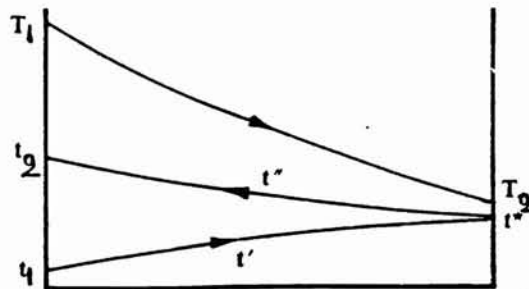

Figure 2.8 Temperature Profile in a 1-2 Shell and Tube Heat Exchanger (Bell, 1993).

Here, the first pass is true parallel and the second pass is counter-current. In this case LMTD cannot be applied directly. It then becomes necessary to develop a new expression for the calculation of the effective or true temperature difference to replace counter-current or parallel LMTD. The effective mean temperature difference for such a case can be carried out along the lines similar to those used to obtain the LMTD. The basic assumptions remain the same, except for the pure co-current or counter-current limitation. An additional assumption required is that each pass has the same amount of heat transfer area. Rather than computing the MTD directly, it is preferable to compute a correction factor F_T for the LMTD assuming pure counter-current flow, i.e.,

$$F_t = \frac{\text{MTD}}{(\text{LMTD})_{\text{counter-current}}} \dots\dots\dots (1)$$

where $F_T = 1$ indicates pure counter-current flow.

Equations for F_T were developed by Underwood and modified by Nagle (1933) and Nagle, Bowman, and Mueller (1940) for a 1-2 shell and tube heat exchanger.

The final expression for the correction factor is :

$$F_T = \frac{\sqrt{(R^2 + 1)} \ln\{(1 - P)/(1 - RP)\}}{(R - 1) \ln\left\{\frac{2 - P(R + 1 - \sqrt{R^2 + 1})}{2 - P(R + 1 + \sqrt{R^2 + 1})}\right\}} \dots\dots\dots(2.26)$$

where $R = \frac{T_1 - T_2}{t_2 - t_1}$ and $P = \frac{t_2 - t_1}{T_1 - t_1}$

To eliminate the necessity for solving the above complicated equation F_T , has been plotted as a function of the parameters R and P. Such a plot is given in figure (2.9) for a 1-n exchanger where 'n' is any even number (Kern, 1950; Perry & Chilton, 1973; Bell, 1983; TEMA, 1988). The total heat transfer area required for multi-pass exchangers is then given by the equation:

$$A^* = \frac{Q_T}{U^*(MTD)} \dots\dots\dots(2.27)$$

where MTD = Mean Temperature Difference, °F or K
 $= F_T(LMTD)_{\text{counter-current}}$

The value of F_T is always less than unity unless one stream is isothermal. This is expected due to the fact that the tube passes in co-current flow with the shell side fluid do not have as great a mean temperature difference as those in counterflow to it.

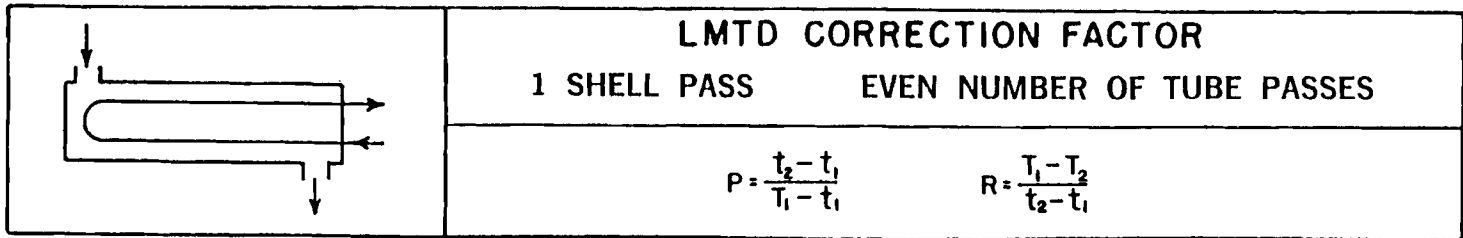
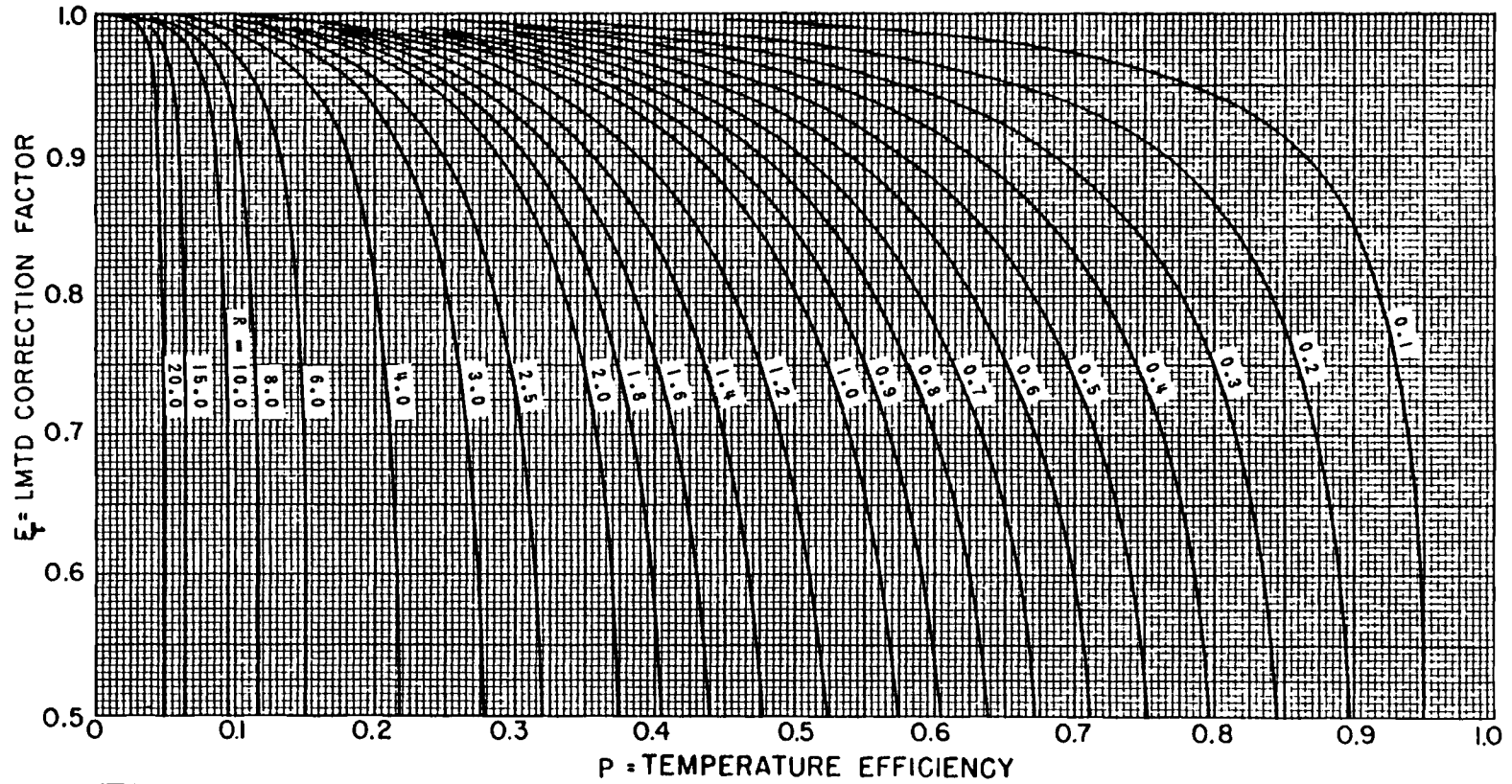

Figure 2.9 LMTD Correction Factor for a 1-n Shell and Tube Exchanger (TEMA, 1988).

The LMTD correction factor F_T can be estimated to a good degree of accuracy without the actual use of the plots. In general, for a single tube pass purely counter-current heat exchanger, $F_T = 1$. For the case of a single shell with any even number of tube-side passes (1-2n heat exchanger), the value of F_T lies between 0.8 and 1.0. The value will be close to 1.0 for the case of nearly isothermal temperature of one stream, and close to 0.8 when the outlet temperatures of both the streams are equal.

Number of Shells Required

The thermodynamic feasibility of a multi-tube pass design has to be checked for the case when the outlet temperature of the cold stream is higher than the hot stream outlet temperature. This is called a temperature cross. Absolute limits for a quick check are (Bell, 1993):

- 1) For hot fluid on the shell side:
$$T_{h,out} > \frac{(T_{c,in} + T_{c,out})}{2}$$
- 2) For cold fluid on the shell side:
$$T_{c,out} < \frac{(T_{h,in} + T_{h,out})}{2}$$

In the event that these limits are approached, it is necessary to use multiple 1-2n shells in series. It is generally highly undesirable to design a one shell, 1-2n heat exchanger when there is a temperature cross. The number of shells required to perform a specified duty can be easily determined graphically as follows (Refer to figure 2.10):

- i) Plot the hot fluid inlet and the cold fluid outlet temperatures on the left hand ordinate, and the hot fluid outlet and cold fluid inlet temperatures on the right hand ordinate. The distance between the ordinates is arbitrary.
- ii) For constant specific heat systems, straight operating lines are drawn from the inlet to the outlet temperature points of each stream. In case of changing specific heat of any

stream, calculate the temperature as a function of the amount of heat added or removed by the other stream. In such a case the operating line(s) will be curved.

iii) Starting with the cold fluid outlet temperature, a horizontal line is drawn until it intercepts the hot fluid line. From that point, a vertical line is drawn until it intercepts the cold fluid line.

iv) This procedure is carried out until a vertical line intercepts the cold fluid operating line at or below the cold fluid inlet temperature or a horizontal line crosses the right hand ordinate.

v) The number of horizontal lines, including the one that crosses the right hand ordinate, is the number of shells in series that is sufficient to perform the required duty. In the case shown, this is three.

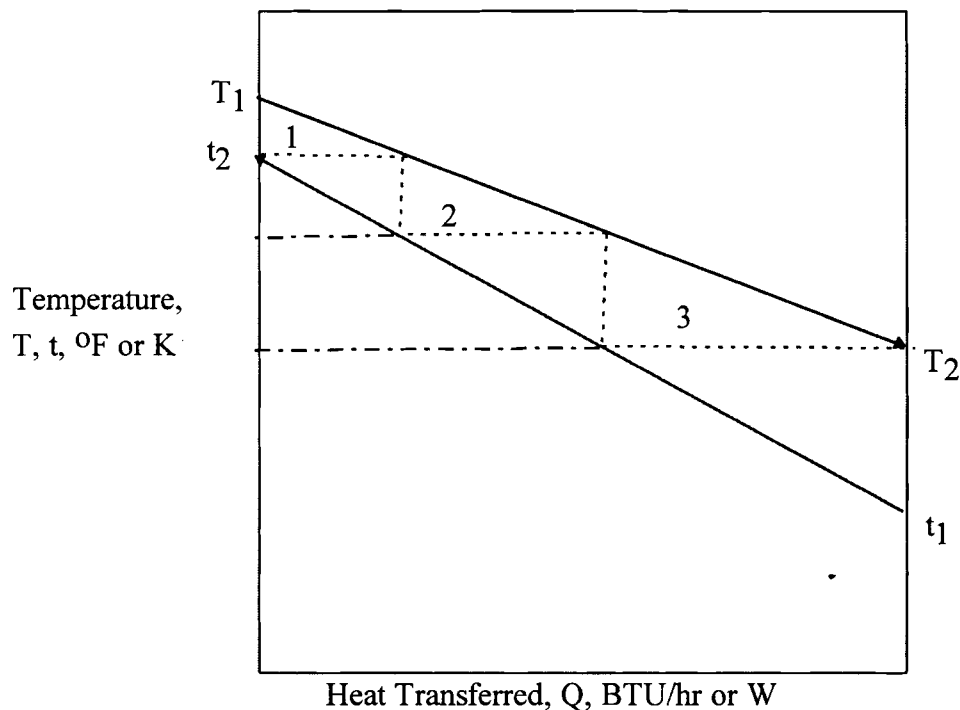

Figure 2.10 Estimation of Number of Shells Required in Series.

Figure 2.10 can also be used to estimate the temperatures of the intermediate stages. Consider shell number 3. As seen in the figure, the hot stream inlet temperature to this stage will be very close to the cold fluid inlet temperature to the second shell, and the cold fluid inlet temperature will be determined by drawing a line parallel to the x-axis until it meets the ordinate. The temperatures to the other stages can be determined in a similar way.

Heat Transfer Area

Once the values of heat duty, Q_T , the mean temperature difference (MTD), and the overall heat transfer coefficient are known, the required heat transfer area can be calculated using the equation

$$A_o = \frac{Q_T}{U_o(MTD)} \dots\dots\dots(2.28)$$

where the overall heat transfer coefficient, U_o , is based on the total tube outer surface area including fins if present.

Once the area A_o is determined, it can be related to the shell inside diameter, and effective tube length through a tube count table. A plot of the heat transfer area in a shell and tube heat exchanger as a function of the shell inside diameter and the effective tube length is given as figure (2.11) for the special case of 19.05 mm. tubes on a 23.81 mm. triangular pitch, fixed tubesheet type exchanger with one tube-side pass, fully tubed shell (Bell, 1993). The term “effective tube length” implies the length of a single straight section from tubesheet to tubesheet for a straight tube exchanger and from tubesheet to tangent line for a U-tube exchanger. As seen in figure (2.11), lines are shown indicating the (L/D_i) ratios (marked 3:1, 6:1, etc.). Shells shorter than three times the shell diameter

(3:1) may suffer from poor fluid distribution and excessive entry and exit losses, and are likely to be more expensive than a unit with a higher L/D_i but the same area, especially if the shell-side fluid is under high pressure. Shells longer than 15 times the shell diameter are likely to be difficult to handle mechanically, and require a large clearway for bundle removal or retubing. Many heat exchangers fall in the 6:1 to 8:1 range, with a pronounced trend towards higher values as pressure drop prediction procedures have improved (Bell, 1993).

Hence, once the area A_o is known, figure (2.11) can be used to determine the combinations of tube length and shell diameter that will provide that area for a given tube size and layout for a single shell, one pass fixed tubesheet exchanger. This then becomes the “base case” for all further calculations.

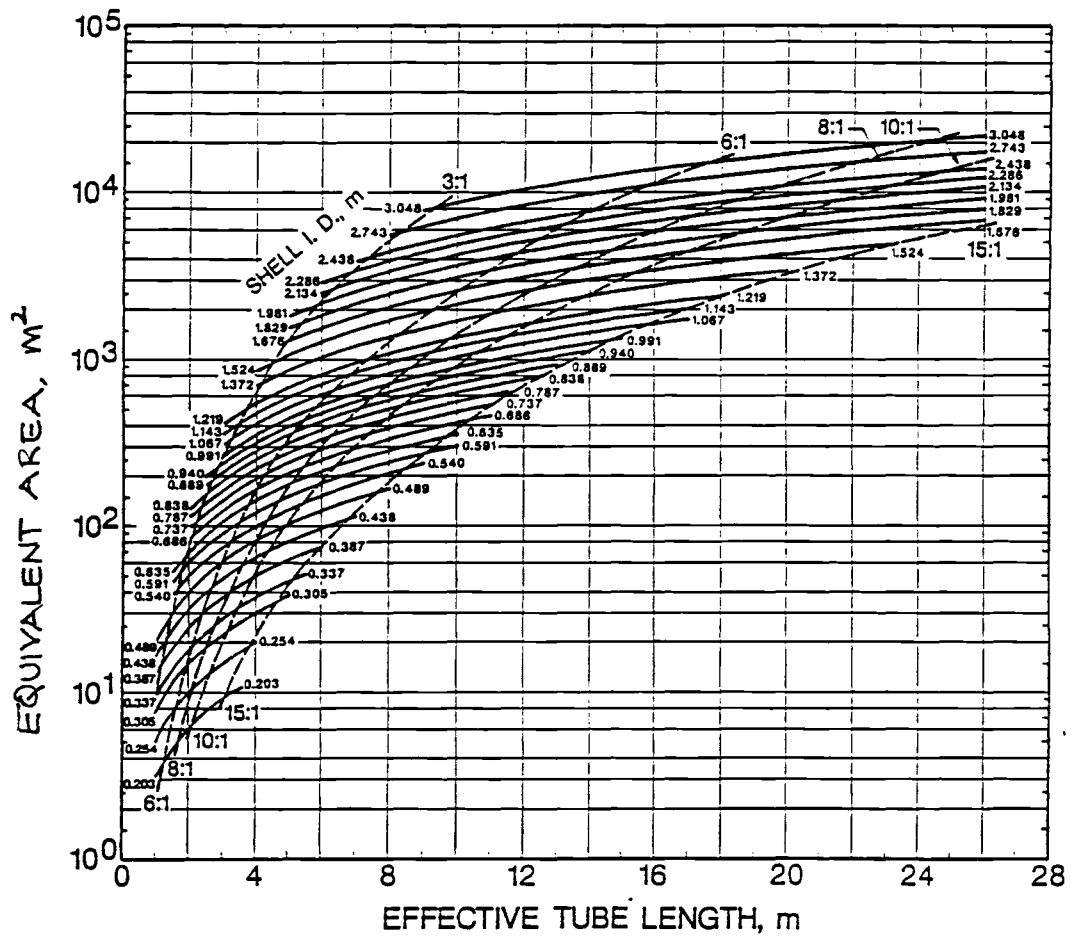

Figure 2.11 Equivalent Area as a Function of Shell Inside Diameter and Effective Tube Length for 19.05 mm. OD Tubes on 23.81 mm. Equilateral Triangular Tube Layout, Fixed Tubesheet, One Tube-side Pass, Fully Tubed Shell (Bell, 1993).

Extension of the “Base Case” to Other Shell/Bundle/Tube Geometries

The calculated area is corrected for the tube size and layout, the type of tube-bundle/shell construction, and the number of tube-side passes for the specific geometry. An “equivalent” area, A'_o is defined by

$$A'_o = A_o F_1 F_2 F_3 F_f \dots\dots\dots(2.29)$$

where A_o = Actual heat transfer area required calculated from Equation (2.28), ft^2 or m^2

F_1 = Correction factor for unit cell tube array
= 1.00 for 19.05 mm. O.D. tubes on 23.81 mm. triangular pitch

F_2 = Correction factor for number of tube - side passes
= 1.00 for one tube - side pass

F_3 = Correction factor for shell construction / tube bundle layout type
= 1.00 for fixed tubesheet type heat exchangers

F_f = Correction factor for finned - tube type exchangers
= 1.00 for plain tubes

The equivalent area A'_o is the one used to enter on the ordinate of figure (2.11). A horizontal line is drawn from this point and various values of the equivalent length and shell diameters are determined. The corresponding L/D_i ratios are also calculated. Choice of a particular $L-D_i$ combination depends to some extent on the amount of space that is available to place the equipment. Generally, the combination that gives an L/D_i ratio of 6:1 to 8:1 is preferred as explained earlier (Bell, 1993). One such combination is then selected for further calculations.

Limitations of the Existing Version of the Approximate Design Method

The existing version of the approximate design method, though it has worked reasonably well for the past several years, has several deficiencies.

- 1) Although a rough procedure for considering finned tubes is given in the footnote in the existing version, no formal procedure is described to incorporate the finned tubes in the tube diameter and layout factor. This present version of the approximate method incorporates the finned tubes by separating the above mentioned factor F_1 into two correction factors, one relating directly to the tube outside diameter, pitch and layout, and the other separately providing for the appropriate multipliers for typical finned tubes (refer to equation 2.27).
- 2) The correction factors F_2 and F_3 are each functions of the shell diameter, but the diameter ranges for each factor are different. This discrepancy is rationalized in the present version.
- 3) The present method provides a means to estimate the number of tubes in a given shell size. This depends on the use of a shell diameter-sensitive "packing factor." This allows a more formal procedure for verifying the correct range of in-tube velocities and the number of tube-side passes required, as a part of the approximate design.
- 4) There is no formal procedure for estimating the baffle cut and baffle spacing in the existing version of the design method. The present version provides a method to estimate the baffle spacing as a function of the shell inside diameter and the baffle cut.
- 5) The present version of the approximate design method incorporates the S.I. units.

CHAPTER III

CORRECTION FACTOR ESTIMATION

Introduction:

At this stage we have the following information available to us:

- i) The total heat load, Q_T .
- ii) The mean temperature difference, MTD.
- iii) The overall heat transfer coefficient, U_o .
- iv) The number of shells needed to perform the required heat duty.
- v) The total heat transfer area required, A_o based on total outside area of tubes including fins.

As explained in the previous chapter, the “base case” needs to be corrected for other shell and tube geometries. This is accomplished by the use of the correction factors F_1 , F_2 , F_3 and F_f (refer to equation 2.29).

Hence, the equation for calculating the “equivalent” area is:

$$A'_o = A_o F_1 F_2 F_3 F_f \dots\dots\dots(3.1)$$

where A_o = Actual heat transfer area required, ft^2 or m^2

F_1 = Correction factor for unit cell tube array

F_2 = Correction factor for number of tube - side passes

F_3 = Correction factor for shell construction / tube bundle layout type

F_f = Correction factor for finned tube type exchangers

The actual heat transfer area A_0 in equation (3.1) is calculated using equation (2.28). In order to use figure (2.11), this area has to be corrected for the particular shell and tube geometry under consideration. This is accomplished by the use of the above mentioned correction factors. The corresponding area estimated using equation (3.1), A'_0 is the equivalent area. This value is used to enter the ordinate of figure (2.11) to estimate the combinations of effective tube length and shell diameter.

We now consider each of the factors individually.

1) Correction Factor for the Unit Cell Tube Array

This correction factor is applied to correct the area for the type of tube layout and angle, tube size and pitch. The reference case for this factor is 19.05 mm. outside diameter tubes on 23.81 mm. triangular pitch, and the factor is defined as:

$$F_1 = \frac{(\text{Heat transfer area / Cross - sectional area of unit cell})_{\text{Reference Case}}}{(\text{Heat transfer area / Cross - sectional area of unit cell})_{\text{New Case}}} \dots\dots\dots(3.2)$$

Table 3.1 gives values of F_1 for various tube sizes and layouts. The value of F_1 is read directly from the table for the particular tube size, type of tube layout and angle, and the tube layout pitch for the case at hand. Appendix F gives the method to calculate the heat transfer area and cross-sectional area of a unit cell.

Table 3.1 : Correction Factor F1 for Unit Cell Tube Array

TUBE O/D in.	TUBE O/D mm.	PITCH RATIO	TUBE PITCH in.	TUBE PITCH mm.	LAYOUT	F ₁
0.250	6.350	1.25	0.313	7.938	→ ◁	0.334
		1.25	0.313	7.938	→ ◻ ◊	0.385
		1.33	0.333	8.446	→ ◁	0.378
		1.33	0.333	8.446	→ ◻ ◊	0.436
		1.50	0.375	9.525	→ ◁	0.480
		1.50	0.375	9.525	→ ◻ ◊	0.555
0.375	9.525	1.25	0.469	11.906	→ ◁	0.500
		1.25	0.469	11.906	→ ◻ ◊	0.577
		1.33	0.499	12.668	→ ◁	0.566
		1.33	0.499	12.668	→ ◻ ◊	0.653
		1.50	0.563	14.288	→ ◁	0.720
		1.50	0.563	14.288	→ ◻ ◊	0.831
0.500	12.700	1.25	0.625	15.875	→ ◁	0.666
		1.25	0.625	15.875	→ ◻ ◊	0.770
		1.33	0.665	16.891	→ ◁	0.755
		1.33	0.665	16.891	→ ◻ ◊	0.871
		1.50	0.750	19.050	→ ◁	0.960
		1.50	0.750	19.050	→ ◻ ◊	1.108
0.625	15.875	1.25	0.781	19.844	→ ◁	0.833
		1.25	0.781	19.844	→ ◻ ◊	0.962
		1.33	0.831	21.114	→ ◁	0.943
		1.33	0.831	21.114	→ ◻ ◊	1.089
		1.50	0.938	23.813	→ ◁	1.200
		1.50	0.938	23.813	→ ◻ ◊	1.385

Table 3.1 : Contd.

TUBE O/D in.	TUBE O/D mm.	PITCH RATIO	TUBE PITCH in.	TUBE PITCH mm.	LAYOUT	F ₁
0.750	19.050	1.25	0.938	23.813	→ ◁	1.000
		1.25	0.938	23.813	→ □ ◇	1.155
		1.33	0.998	25.337	→ ◁	1.132
		1.33	0.998	25.337	→ □ ◇	1.307
		1.50	1.125	28.575	→ ◁	1.440
		1.50	1.125	28.575	→ □ ◇	1.663
0.875	22.225	1.25	1.094	27.781	→ ◁	1.166
		1.25	1.094	27.781	→ □ ◇	1.347
		1.33	1.164	29.559	→ ◁	1.320
		1.33	1.164	29.559	→ □ ◇	1.525
		1.50	1.313	33.338	→ ◁	1.679
		1.50	1.313	33.338	→ □ ◇	1.939
1.000	25.400	1.25	1.250	31.750	→ ◁	1.333
		1.25	1.250	31.750	→ □ ◇	1.539
		1.33	1.330	33.782	→ ◁	1.509
		1.33	1.330	33.782	→ □ ◇	1.743
		1.50	1.500	38.100	→ ◁	1.920
		1.50	1.500	38.100	→ □ ◇	2.216
1.250	31.750	1.25	1.563	39.688	→ ◁	1.666
		1.25	1.563	39.688	→ □ ◇	1.924
		1.33	1.663	42.228	→ ◁	1.887
		1.33	1.663	42.228	→ □ ◇	2.178
		1.50	1.875	47.625	→ ◁	2.400
		1.50	1.875	47.625	→ □ ◇	2.771

Table 3.1 : Contd.

TUBE O/D in.	TUBE O/D mm.	PITCH RATIO	TUBE PITCH in.	TUBE PITCH mm.	LAYOUT	F₁
1.500	38.100	1.25	1.875	47.625	→ ◁	1.999
		1.25	1.875	47.625	→ ◻ ◊	2.309
		1.33	1.995	50.673	→ ◁	2.264
		1.33	1.995	50.673	→ ◻ ◊	2.614
		1.50	2.250	57.150	→ ◁	2.879
		1.50	2.250	57.150	→ ◻ ◊	3.325
2.000	50.800	1.25	2.500	63.500	→ ◁	2.666
		1.25	2.500	63.500	→ ◻ ◊	3.078
		1.33	2.660	67.564	→ ◁	3.018
		1.33	2.660	67.564	→ ◻ ◊	3.485
		1.50	3.000	76.200	→ ◁	3.839
		1.50	3.000	76.200	→ ◻ ◊	4.433

2) Correction Factor for Number of Tube-side Passes

This factor is applied when the number of tube-side passes is greater than 1(one), i.e., $F_2 = 1$ for one tube-side pass. The correction factor is defined as

$$F_2 = \frac{\text{Number of tubes in heat exchanger with one tube - side pass}}{\text{Number of tubes in heat exchanger with 'n' tube - side passes}} \dots\dots\dots(3.3)$$

where $n = 2, 4, 6, \dots$, and the heat exchangers have the same tube layout and inside shell diameter.

This factor is given in the existing version of the approximate design method but, it has been recalculated here using a different, and relatively new database. The tube counts used to calculate these values are different from those used in the existing version, and hence, the values of F_2 are also somewhat different than those given in the existing version. For a given exchanger configuration, F_2 is a function of the shell inside diameter and the number of tube-side passes. Table 3.2 gives values of factor F_2 for 19.05 mm. outside diameter tubes on 23.81 mm. triangular pitch and a pitch ratio (PR) of 1.25 for various types of configurations. For any other tube size and layout, this factor has to be used with the correction factor F_1 . For a U-tube type heat exchanger, there is a minimum of two tube-side passes, and hence, this factor has to be considered. Given in Appendix G are the detailed tables for F_2 and plots of F_2 vs. the shell inside diameter, D_i . The tube counts used for the evaluation of F_2 are given in Appendix E (Saunders, 1988).

Table 3.2 : Correction Factor F_2 for Number of Tube-side Passes.

D_i m.	FACTOR F_2		
	2 PASSES	4 PASSES	6 PASSES
0.203-0.337	1.113	1.400	1.613
0.387-0.540	1.059	1.173	1.244
0.591-0.737	1.038	1.109	1.151
0.787-0.940	1.029	1.080	1.109
0.991-1.219	1.022	1.061	1.083
1.295-1.524	1.017	1.047	1.063

As is seen in Appendix G, the values for F_2 vary substantially for the different configurations with the lowest being that for fixed tubesheet heat exchangers. As an example consider F_2 for 4 (four) tube-side passes over the diameter range of 0.203 m - 0.337 m. The value of F_2 for the various configurations are as follows:

- 1) Fixed tubesheet exchangers = 1.113
- 2) U-tube exchangers = 1.165
- 3) Split backing ring floating head exchangers = 1.561
- 4) Pull-through floating head exchangers (1000 KPa pressure) = 1.692
- 5) Pull-through floating head exchangers (2000 KPa pressure) = 1.754

This indicates that for the same diameter, more tubes can be accommodated in a fixed tubesheet exchanger than any other configuration. It also indicates that as the number of tube-side passes increase, more tubes are lost in the other configurations as compared to the fixed tubesheet type. This implies that a smaller fixed tubesheet type exchanger would be required to perform the same duty. It is not always possible to utilize this fact as many factors affect the choice of the exchanger configuration such as differential expansion.

3) Correction Factor for Shell Construction/Tube-bundle Layout Type

This factor, F_3 , is defined as

$$F_3 = \frac{\text{Number of tubes in 'n' tube - side passes of fixed tubesheet exchanger}}{\text{Number of tubes in 'n' tube - side passes of other type of exchanger}} \dots\dots\dots(3.4)$$

where $n = 1, 2, 4, \dots$, and the heat exchangers have the same tube layout, shell inside diameters, and number of passes.

As is evident from the above equation, the reference case for this factor is the fixed tubesheet type exchanger. Hence, for 1-2 split ring floating head type of exchanger, factor F_3 is estimated as

$$F_3 = \frac{\text{Number of tubes in 2 tube - side passes of fixed tubesheet exchanger}}{\text{Number of tubes in 2 tube - side passes of SRFH type of exchanger}} \dots\dots\dots(3.5)$$

The data used in the evaluation of F_3 is given in Appendix E and tables and plots of F_3 as a function of shell inside diameter are given in Appendix H. The value of F_3 is based on the data for 19.05 mm. outside diameter tubes on a 23.81 mm. triangular pitch and a PR of 1.25 (Saunders, 1988). For other tube sizes and tube layouts, this factor is used in conjunction with factor F_1 . Table 3.3 gives values of F_3 for various types of shell and tube heat exchangers over a range of shell inside diameters. As is evident from the values indicated in Table 3.3 and Appendix H, more tubes can be accommodated in a fixed tubesheet exchanger than any other configuration for the same shell inside diameter and number of tube-side passes.

Table 3.3 : Correction Factor F₃ for Various Tube Bundle Constructions.

Type of Tube Bundle Construction	F ₃					
	Inside Shell Diameter m.					
	0.203-0.337	0.387-0.540	0.591-0.737	0.787-0.940	0.991-1.219	1.295-1.524
Fixed Tubesheet (TEMA L, M, or N)	1.000	1.000	1.000	1.000	1.000	1.000
U-Tube (TEMA U)	1.065	1.072	1.047	1.034	1.024	1.020
Split Backing Ring (TEMA S)	1.213	1.112	1.090	1.072	1.059	1.045
Pull-through Floating Head (1000 KPa Pressure, TEMA T)	2.431	1.532	1.342	1.258	1.200	1.165
Pull-through Floating Head (2000 KPa Pressure, TEMA T)	2.500	1.589	1.395	1.311	1.244	1.201

4) Correction Factor for Finned-tube Type Exchangers

This factor is applied when low finned tubes are employed in the exchanger and is defined as

$$F_f = \frac{\text{Outside surface area per unit length of plain tube}}{\text{Outside surface area per unit length of finned tube}} \dots\dots\dots(3.6)$$

Figure 3.1 shows the dimensional nomenclature used for the finned tube (Bell & Mueller, 1984).

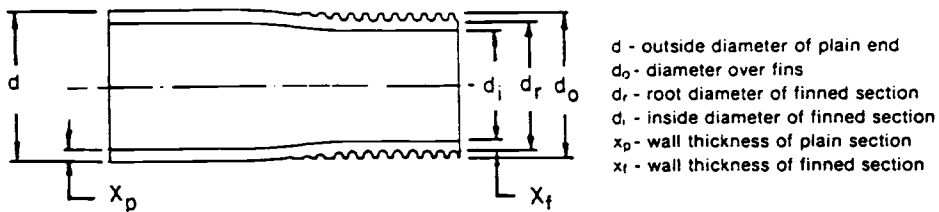

Figure 3.1 Dimensional Nomenclature Used for Type S/T Trufin Finned Tubes (Bell & Mueller, 1984).

As is evident from equation (3.6), $F_f = 1.0$ for plain tubes. Values of F_f can be read directly from Table 3.4. The data used in the estimation of F_f (Bell & Mueller, 1984) is given in Appendices C and D.

Table 3.4 : Correction Factor F_f for Low-finned Tubes

OUTSIDE DIA. in.	OUTSIDE DIA. mm.	FINS PER INCH	ROOT DIAMETER		FACTOR F_f
			d_r		
			in.	mm.	
0.375	9.525	19	0.250	6.350	0.436
0.500	12.700	19	0.375	9.525	0.411
0.500	12.700	19	0.375	9.525	0.318
0.500	12.700	16	0.375	9.525	0.504
0.625	15.875	16	0.500	12.700	0.482
0.625	15.875	19	0.500	12.700	0.399
0.625	15.875	19	0.500	12.700	0.410
0.625	15.875	26	0.500	12.700	0.299
0.625	15.875	32	0.557	14.148	0.415
0.750	19.050	11	0.500	12.700	0.373
0.750	19.050	16	0.625	15.875	0.402
0.750	19.050	19	0.625	15.875	0.392
0.750	19.050	19	0.625	15.875	0.390
0.750	19.050	19	0.625	15.875	0.390
0.750	19.050	26	0.625	15.875	0.306
0.750	19.050	26	0.640	16.256	0.311
0.750	19.050	28	0.672	17.069	0.377
0.750	19.050	32	0.682	17.323	0.390
0.750	19.050	40	0.675	17.145	0.304
0.750	19.050	40	0.625	15.875	0.212

Table 3.4 : Contd.

OUTSIDE DIA. in.	OUTSIDE DIA. mm.	FINS PER INCH	ROOT DIAMETER		FACTOR F_f
			d_r		
			in.	mm.	
0.875	22.225	11	0.625	15.875	0.361
0.875	22.225	16	0.750	19.050	0.458
0.875	22.225	19	0.750	19.050	0.385
0.875	22.225	19	0.750	19.050	0.385
0.875	22.225	28	0.797	20.244	0.375
0.875	22.225	32	0.807	20.498	0.387
1.000	25.400	11	0.750	19.050	0.353
1.000	25.400	16	0.875	22.225	0.452
1.000	25.400	19	0.875	22.225	0.381
1.000	25.400	26	0.890	22.606	0.298
1.000	25.400	26	0.875	22.225	0.293
1.000	25.400	28	0.922	23.419	0.374
1.000	25.400	32	0.932	23.673	0.386

5) Estimation of Equivalent Area

Once the actual heat transfer area, A_o is calculated using equation (2.26), and the above mentioned factors are determined for the specific shell and tube geometry, the “equivalent” area is estimated using Equation (2.29) as given below:

$$A'_o = A_o F_1 F_2 F_3 F_f \dots\dots\dots(2.29)$$

where A_o = Actual heat transfer area required calculated from Equation(2.28), ft^2 or m^2

F_1 = Correction factor for unit cell tube array

F_2 = Correction factor for number of tube- side passes

F_3 = Correction factor for shell construction/ tube bundle type

F_f = Correction factor for finned tube exchangers

A plot has been prepared, figure (2.11), for the equivalent area, A'_o as a function of shell inside diameter, effective tube length, and the L/D_i ratio for the special case of 19.05 mm. outside diameter plain tubes on a 23.81 mm. triangular pitch in a fixed tubesheet type exchanger with one tube-side pass, fully tubed shell.

As explained earlier, once the required heat transfer area is calculated using Equation (2.28), the equivalent area is estimated using the above mentioned correction factors for the specific geometry. This area is then used to enter on the ordinate of Figure (2.11) to determine the combinations of the effective tube length and shell inside diameter that will provide the required area A_o (calculated using equation 2.28).

6) Estimation of Effective Tube Length and Shell Inside Diameter

The plot is entered on the ordinate of figure (2.11) at the value of the equivalent area calculated by equation (2.29). For this value of A_0' , various combinations of the effective tube length, shell inside diameter, and the corresponding L/D_i values are determined. As is seen in the figure, the L/D_i values range from 3:1 to 15:1.

CHAPTER IV

PARAMETER ESTIMATION

Introduction

Given below is a method to estimate the tube count for a given shell size and tubesheet type and an estimation procedure for the baffle spacing as a function of the baffle cut and shell inside diameter. The baffle spacing has a direct bearing on the shell-side fluid velocity and pressure drop and hence is an important factor to be considered in the design of shell and tube heat exchangers. Both the above mentioned methods are not given in the existing version of the design method.

1) Estimation of Tube Count for a Given Shell Inside Diameter and Exchanger Type

The number of tubes for a given shell size and tubesheet type depends on the tube pitch, tube layout angle, number of tube-side passes and pass partition plates, diameter of outer tube limit, tube diameter, tube bundle type (fixed tubesheet, U-tube bundle, floating head type, etc.), presence of impingement plate, tie rods, available pressure drop, etc.. Some standard tube count tables are compiled and are available in the open literature (Kern, 1950; Perry & Chilton, 1973; Saunders, 1988). Computer programs are used to lay out the tube fields and count the tubes. Some manufacturers have their own standard tables. In any case, accurate estimates are difficult to obtain due to the large number of

variables which must be considered. For an initial design, a simple, but, a reasonably accurate estimate can be made as follows:

$$N_t = F_p \frac{A_s}{A_c} \dots\dots\dots(4.1)$$

where N_t = Total number of tubes

F_p = Packing factor

$$A_s = \text{Area of outer tube limit, ft}^2 \text{ or m}^2$$

$$= \frac{\pi}{4} D_{otl}^2$$

A_c = Cross-sectional area of unit cell, ft² or m²

Hence equation 4.1 can be expressed as

$$N_t = \frac{\pi F_p}{4 C_t} \left\{ \frac{D_{otl}}{L_{tp}} \right\}^2 = 0.785 \frac{F_p}{C_t} \left\{ \frac{D_{otl}}{L_{tp}} \right\}^2 \dots\dots\dots(4.2)$$

where D_{otl} = Diameter of outer tube limit, in. or mm

L_{tp} = Tube layout pitch, in. or mm

C_t = Tube layout angle constant

$$= 0.866 \text{ for } 30^\circ \text{ angle}$$

$$= 1.000 \text{ for } 45^\circ \text{ and } 90^\circ \text{ layout angles}$$

The value of F_p depends mainly on the tube layout pitch, L_{tp} , and the diameter of outer tube limit, D_{otl} .

F_p values for various heat exchanger configurations are given in Appendix I.

2) Estimation of Baffle Cut and Spacing for a Given Shell Size.

Baffles have two very important functions.

- i) To provide support for the tubes against sagging and damage due to vibrations caused by the fluids flowing through and across them.
- ii) To increase the heat transfer coefficient as much as possible by directing the flow and increasing velocity without violating the available pressure drop limitations.

Several types of baffles are available but the most commonly used in shell and tube exchangers is the single segmental type. These give higher heat transfer coefficients and pressure drop by increasing the velocity of the shell-side fluid. The heat transfer coefficient and the pressure drop across the exchanger also depend on the baffle spacing and baffle cut and hence these are considered in some detail in this section. To do this, we first define the terms baffle cut and baffle spacing.

Baffle Cut:

This is basically the size of the segment removed and is usually specified as a percent of the shell inside diameter. As the baffle cut increases, the flow pattern deviates increasingly from crossflow. The segment sheared off must be less than half the diameter to insure that adjacent baffles overlap at least one full tube row. For liquid flows on the shell-side, a baffle cut of 20-25 percent of the diameter is common; for low pressure gas flows, 40-45 percent (i.e., close to the maximum allowable cut) is more common, in order to minimize pressure drop (Bell & Mueller, 1984).

Baffle Spacing:

This is defined as the spacing between two adjacent baffles. For given shell and tube diameters, tube layout, and the shell-side flow rate, the baffle cut determines the flow velocity through the window (the space from the top of the baffle to the shell inside diameter), whereas the baffle spacing determines the crossflow velocity. Hence, both

baffle cut and baffle spacing influence the fluid velocity and hence, the heat transfer coefficient and pressure drop on the shell-side.

TEMA (TEMA, 1988) specifies a minimum baffle spacing of 20% of the shell diameter or 2 inches, whichever is greater. It also specifies the maximum allowable spacing depending upon the tube outside diameter and materials of construction.

The underlying principle for the estimation of baffle spacing is that the velocities in the window and crossflow regions should be approximately equal. The advantage of having approximately equal velocities in the crossflow and window regions is that it tends to maximize the effective use of the available pressure drop to create higher heat transfer coefficients. It also tends to make the tube-bundle more rigid. This is particularly important where tube vibration is expected to occur. This principle is also used in the NTIW (No Tubes In the Window) design where every tube passes through and is supported by every baffle guiding the flow. The loss in the number of tubes can be minimized by having small baffle cuts and an increase in shell-side fluid velocity (especially through the window) resulting in a significant increase in shell-side heat transfer coefficient (Bell, 1993). Based on the above principle, the following procedure is used to determine the relationships between baffle cut, baffle spacing and shell inside diameter.

a) Crossflow Area At or Near the Centerline for One Crossflow Section

i) For plain tubes on rotated and inline square layouts.

$$S_m = l_s \left\{ (D_i - D_{otl}) + \left(\frac{D_{otl} - d_o}{p_n} \right) (p - d_o) \right\} \dots\dots\dots(4.3)$$

where S_m = Crossflow area at or near centerline for one crossflow section,

$$\text{ft}^2 \text{ or } \text{m}^2$$

l_s = Baffle spacing, in. or mm

d_o = Outer diameter of plain tube, in. or mm

p_n = Tube pitch normal to flow, in. or mm

p = Tube pitch, in. or mm

ii) For plain tubes on triangular layouts

$$S_m = l_s \left\{ (D_i - D_{otl}) + \left(\frac{D_{otl} - d_o}{p} \right) [(p - d_o)] \right\} \dots\dots\dots(4.4)$$

The nomenclature is as in equation (4.3).

b) Baffle Cut Angle:

This is the angle subtended by the intersection of the cut edge of the baffle with the inside surface of the shell

$$\theta = 2 \cos^{-1} \left\{ 1 - \frac{2l_c}{D_i} \right\} \dots\dots\dots(4.6)$$

where θ = Baffle cut angle, radians

c) Area for Flow Through Window

$$S_w = S_{wg} - S_{wt} \dots\dots\dots(4.6)$$

= Gross window area - Window area occupied by tubes.

$$S_{wg} = \frac{D_i^2}{4} \left\{ \frac{\theta}{2} - \left[1 - 2 \frac{l_c}{D_i} \right] \sin\left(\frac{\theta}{2}\right) \right\} \dots\dots\dots(4.7)$$

$$S_{wt} = \frac{N_t}{8} (1 - F_c) \pi d_o^2 \dots\dots\dots(4.8)$$

where F_c is the fraction of total tubes in crossflow and can be calculated from

$$F_c = \frac{1}{\pi} \left\{ \pi + 2 \left(\frac{D_i - 2l_c}{D_{otl}} \right) \sin \left[\cos^{-1} \left(\frac{D_i - 2l_c}{D_{otl}} \right) \right] - 2 \left[\cos^{-1} \left(\frac{D_i - 2l_c}{D_{otl}} \right) \right] \right\} \dots\dots\dots(4.9)$$

where l_c = Baffle cut, in. or mm

Assuming that the area of crossflow is equal to the area for flow through the window, we get the following relationship:

$$S_m = S_w = S_{wg} - S_{wt} \dots\dots\dots(4.10)$$

This equation can be simplified to get a relationship for the baffle spacing as a function of the shell inside diameter, and the baffle cut.

For plain tubes on triangular layouts,

$$l_s = \frac{\frac{D_i^2}{4} \left\{ \frac{\theta}{2} - \left[1 - 2 \left(\frac{l_c}{D_i} \right) \right] \sin\left(\frac{\theta}{2}\right) \right\} - \frac{N_t}{8} (1 - F_c) \pi d_o^2}{\left\{ D_i - D_{otl} + \left(\frac{D_{otl} - d_o}{p} \right) [(p - d_o)] \right\}} \dots\dots\dots(4.11)$$

For convenience, a plot of l_s/D_i vs. $(l_c/D_i)*100$, for the various bundle configurations for the special case of 19.05 mm. outside diameter plain tubes on 23.81 mm. triangular pitch, is given in Appendix J. Also given are plots for 19.05 mm OD tubes on 25.4 mm triangular pitch and 19.05 mm OD tubes on 25.4 mm square pitch. The results show that the baffle spacing is not a very strong function of the tube size and pitch. It is more dependent on the shell inside diameter, baffle cut, and diameter of outer tube limit.

Tube Vibrations

Damaging tube vibration can occur under certain conditions of shell-side flow relative to baffle configuration and unsupported tube span (TEMA, 1988). The designer should consider the use of shorter unsupported tube spans by a modification of the internal baffle configuration. This includes the baffle spacing, the tube-tube hole clearance and the use of the no-tube-in-window (NTIW) design. Another method used to prevent failures due to flow induced vibration is the use of the RODbaffle (RBE) type of shell and tube exchanger first developed and patented by the Phillips Petroleum Co. in 1970. As the name implies, the supports for the tubes are rods instead of the conventional perforated plate baffles.

TEMA Standards specify the maximum unsupported tube span for a shell size. The potential for tube vibration can occur at any one or more of the following locations within the heat exchanger:

- 1) Main section of the heat exchanger bundle where the baffles are generally of equal spacing and there may be repeated impact between adjacent tubes at mid-span. Cutting at the baffles can also occur, particularly if the baffles are thin or harder than the tubes or there is a large baffle hole-tube clearance due to repeated impact between tubes and baffles due to thermal expansion.

- 2) Inlet and outlet sections of the tube bundle at or near the shell nozzles where the unsupported tube span is usually the highest and the local velocities are highest due to the nozzles.
- 3) U-bends.
- 4) Underneath the nozzles.
- 5) Tubes that pass through the window.

Mechanisms of Tube Vibration

Tube vibrations in shell and tube heat exchangers may be induced by the shell-side fluid flow, tube-side fluid flow, or mechanically transmitted vibration from other equipment. The most frequently encountered source of tube excitation is from shell-side fluid flow. This source is solely dependent upon the design of the heat exchanger. Several mechanisms that may cause tube vibration, as described in the literature (Barrington, 1973; Chen & Weber, 1970; Kissel, 1973; TEMA, 1988; Walker & Reising, 1968), are as follows:

- 1) A natural frequency of the tubes may coincide with the vortex shedding frequency of the fluid in crossflow to the tubes and excite large resonant vibration amplitudes.
- 2) Turbulent pressure fluctuations occurring in the wake of a cylinder or carried to the cylinder from an upstream disturbance may provide a potential mechanism for tube vibration. The tubes respond to that portion of the energy spectrum that is close to their natural frequency. The amplitude of vibration may be very small at low flow rates and increases in direct proportion to the dynamic head.
- 3) Fluidelastic coupling occurs when the fluid flowing past the tubes causes them to vibrate with a large whirling motion. The vibration is self-excited and, once initiated, will grow in amplitude.

4) Tubes experiencing axial flow are subject to flow induced vibration resulting, in part from the flow parallel to the tubes, and in part from the crossflow components that exist in any real axial flow situation.

5) If the shell-side fluid is a low density gas, acoustic resonance or coupling may occur. This happens when standing waves in the shell are in phase with the vortex shedding from the tubes. These standing waves are perpendicular to the direction of crossflow and the axis of the tubes. Although this phenomenon can result in a serious noise problem, it usually does not cause significant tube vibration amplitude or damage. Standing waves in a liquid or dense fluid are normally too small to produce the same effect.

All the above mentioned factors have to be considered in the event that there exists a possibility of tube vibration problems during the operation of the heat exchanger.

CHAPTER V

SUMMARY AND CONCLUSIONS

Summary:

Shell and tube heat exchangers are the most common type of heat exchangers used in the Chemical Process Industry. They are one of the most important components in a process that can be used to achieve large amounts of energy savings. Numerous computer programs as well as the hand-based Delaware method are available for the detailed design but this is an unnecessary, time consuming activity at the initial stages of a project. A "Quick Manual Design," though approximate, will give an experienced designer a fair idea of the actual size of the heat exchanger after detailed design. This is important in the initial stages in that it can be used to obtain an estimate of the cost of the equipment which in turn is required at the time of the cost estimation of the project. Another advantage of such an approximate design is in the preparation of the plant layout and the piping and instrumentation diagram. The results from the approximate method will also be good starting points for the detailed design that requires some iterative solution. These results can also be used as a check for the results obtained using computer programs. This thesis is a modification of such an approximate design method.

- 1) All the correction factors in the presented version of the design method have been recalculated using a totally different database and hence there is some difference in the various values of the correction factors, as compared to the existing version.

2) The correction factor for the presence of finned tubes presented here was considered only as a footnote for factor F_1 . The present version gives a new factor F_f to account for the presence of finned tubes.

3) No formal procedure is given in the existing version to estimate the tube counts or the baffle spacing. These are covered in this thesis.

A summary of the approximate design method is as follows:

- 1) Calculate the total amount of heat to be transferred, i.e., the total heat duty, Q_T .
- 2) Estimate the individual heat transfer coefficients (α 's) from available literature (also given in Appendix A).
- 3) Estimate the fouling factors, if required, from available literature (also given in Appendix A).
- 4) If finned-tubes are employed in the service, choose the fin dimensions, calculate the fin efficiency using equation (2.7) or estimate it for the material of construction and dimensions as explained in Chapter II (close to 1.0 for highly conducting materials and low heat transfer coefficients), or calculate the resistance to heat transfer due to the presence of fins using equation (2.10).
- 5) Calculate the thermal resistance of the tube wall.
- 6) Once the values of the resistances have been determined, calculate the overall heat transfer coefficient using equation (2.13).
- 7) Estimate the number of shells required in series to perform the required heat duty.
- 8) Calculate the AMTD using equation (2.23).
- 9) Estimate the LMTD for the specified temperature conditions using the calculated value of the AMTD.
- 10) Estimate the LMTD correction factor F_T based on flow configuration (and outlet temperatures for multi-pass designs).
- 11) Estimate the MTD using equation (2.25).

- 12) Once the values of Q_T , U_o , and MTD are known, calculate the required total outside heat transfer area including fins using equation (2.28).
- 13) Estimate the correction factor F_1 for the tube size, tube layout, and pitch from Table (3.1).
- 14) Estimate correction factor F_2 for number of tube-side passes as a function of the shell inside diameter from Table (3.2).
- 15) Estimate the correction factor F_3 for the shell construction/tube-bundle type from Table (3.3).
- 16) Estimate correction factor F_f for finned tubes from Table (3.4).
- 17) Calculate the “equivalent” area to be used to enter the ordinate of Figure (2.11) using Equation (2.29).
- 18) Determine the various length-shell inside diameter combinations from figure (2.11).
- 19) Select a value of the effective length and shell inside diameter which gives an L/D_i in the range of 6:1 to 8:1.

Conclusions

- 1) The approximate design method can be used to perform a quick preliminary design of shell and tube heat exchangers. This can be useful at the initial stages of a project for cost estimation and preparation of the plant layout and P & I diagrams.
- 2) The approximate design method will be a useful tool for performing a quick manual check of any available design.
- 3) The approximate design method can be used to check the validity of computer based designs.
- 4) The method works well for estimating various parameters which can be used as input variables in the detailed and iterative design methods thus saving time.
- 5) This approximate design method can be a useful pedagogical tool.

- 6) The present version of the approximate design method takes into account the presence of finned tubes by providing a correction factor F_f to estimate the "equivalent" area. In the existing version of the approximate method, this factor was combined with factor F_1 , and only as a footnote.
- 7) The existing version of the approximate design method gives factors F_2 and F_3 over varying shell inside diameter ranges. The present version has rationalized this, i.e., it gives the factors over the same diameter ranges.
- 8) The present version incorporates S.I units.
- 9) The present version provides a method to estimate the baffle spacing as a function of baffle cut and shell inside diameter.

CHAPTER VI

RECOMMENDATIONS

- 1) The method presented to estimate the tube count using the packing factor is not very useful as it stands. It needs to be worked on to get as few figures as possible without a substantial loss of accuracy.
- 2) Some type of vibration analysis should be incorporated in this method.
- 3) The method should include some type of optimization criteria such as minimizing the heat transfer area, utilizing maximum available pressure drop, etc.
- 4) Some guidelines need to be provided on the selection of velocities and hence number of tubes in parallel, number of tube-side passes, etc.

BIBLIOGRAPHY

- Barrington, E. A. (1973). Acoustic Vibrations in Tubular Exchangers. Chemical Engineering Progress, 69(7), pp. 62-68.
- Bell, K. J. (1960). Exchanger Design Based on the Delaware Research Program. Petro./Chem. Eng., 32 (October), pp. C-26-C-40c.
- Bell, K. J. (1963). Final Report of the Co-operative Research Program on Shell and Tube Heat Exchangers, Bulletin No. 5. University of Delaware Engineering Experiment Station.
- Bell, K. J. (1978). Estimate S & T Exchanger Design Fast. Oil and Gas Journal 76 (December, 4), pp. 59-68.
- Bell K.J. (1983). In Schlunder, E. U. (Ed.). Heat Exchanger Design Handbook. Washington, D.C. Hemisphere Publishing Corp.
- Bell, K. J. (1993). Overall Design Methodology for Shell and Tube Heat Exchangers. Class Notes.
- Bell K. J. (1993). Typical Overall Design Coefficients for Shell and Tube Heat Exchangers. Class Notes.
- Bell, K. J., & Mueller, A. C. (1984). Engineering Data Book II. Wolverine Tube, Inc.
- Bowman, R. A., Mueller, A. C., & Nagle, W. M. (1940). Mean Temperature Difference in Design. Trans. ASME, 62 (May), pp. 283-294.
- Bowman, T., & Turton, R. (1990). Quick Design and Evaluation: Heat Exchangers. Chemical Engineering 27(7), pp. 92-99.
- Briggs, D. E., Katz, D. L., & Young, E. H. (1963). How to Design Finned-Tube Heat Exchangers. Chemical Engineering Progress, 59(11), pp. 49-59.

- Briggs, D. E., & Young, E. H. (1965). Convection Heat Transfer and Pressure Drop of Air Flowing Across Triangular Pitch Banks of Finned Tubes. Chem. Eng. Prog. Symp. Series, 59(41), pp.1-10.
- Chen, Y. N., & Weber, M. (1970). Flow Induced Vibrations in Tube Bundle Heat Exchangers with Cross and Parallel Flow. In Symposium on Flow-Induced Vibration in Heat Exchangers, (December, 1) New York: American Society of Mechanical Engineers, pp. 57-77.
- Colburn, A. P. (1933). A Method of Correlating Forced Convection Heat Transfer Data and a Comparison with Fluid Friction. Transactions of the AIChE, 29, pp. 174-210.
- Cook, E. M. (1964a). Comparison of Equipment for Removing Heat from Process Streams. Chem. Eng. 71 (May, 25), pp. 137-142.
- Fischer, F. K. (1938). Mean Temperature Difference Correction in Multipass Exchangers. Ind. Eng. Chem., 30(4), pp. 377-383.
- Gilmour, C. H. (1952). Short Cut to Heat Exchanger Design-I. Chemical Engineering (October), pp. 144-148.
- Gilmour, C. H. (1953a). Short Cut to Heat Exchanger Design- II. Chemical Engineering (March), pp. 226-229.
- Gilmour, C. H. (1953b). Short Cut to Heat Exchanger Design- III. Chemical Engineering (April), pp. 214-218.
- Gilmour, C. H. (1953c). Short Cut to Heat Exchanger Design- IV. Chemical Engineering (October), pp. 203-208.
- Gilmour, C. H. (1954a). Short Cut to Heat Exchanger Design- V. Chemical Engineering (February), pp. 190-195.
- Gilmour, C. H. (1954b). Short Cut to Heat Exchanger Design- VI. Chemical Engineering (March), pp. 209-213.
- Gilmour, C. H. (1954c). Short Cut to Heat Exchanger Design- VII. Chemical Engineering (August), pp. 199-206.
- Hutchinson, E. (1945). On the Measurement of the Thermal Conductivity of Liquids. Trans. Faraday Soc., 41, pp. 87-92.
- Jaw, L. (1964). Temperature Relations in Shell-and-Tube Exchangers Having One-Pass Split-Flow Shells. Trans. ASME, 86 (August), pp. 408-416.

- Kern, D. Q. (1950). Process Heat Transfer. New York: McGraw Hill Book Co.
- Kern, D. Q., and Kraus, A. D. (1972). Extended Surface Heat Transfer. New York: McGraw-Hill.
- Kissel, J. H. (1973). Flow Induced Vibrations in Heat Exchangers-A Practical Look. Machine Design, 45(11), pp. 104-107.
- Linnhoff, B. (1982). User Guide on Process Integration for the Efficient Use of Energy. London: Institution of Chemical Engineers.
- Lohrisch, F. W. (1963). What are Optimum Exchanger Conditions? Hydrocarbon Process. Petrol. Refiner, 42(5), pp. 177-180.
- Lord, R. C., Minton, P. E., & Slusser, R. P. (1970). Design of Heat Exchangers. Chemical Engineering, 77(2), pp. 96-118.
- McAdams, W. H. (1954). Heat Transmission (3rd ed.). New York: McGraw Hill Book Company inc.
- McKetta, J. J. (Ed.). (1992). Heat Transfer Design Methods. New York: Marcel Dekker Inc.
- Morton, D. S. (1962). Heat Exchangers Dominate Process Heat Transfer. Chem. Eng., 69(June, 11), pp. 170-176.
- Nagle, W. M. (1933). Mean Temperature Differences in Multipass Heat Exchangers. Ind. Eng. Chem., 25(6), pp. 604-608.
- Perry, R. H., & Chilton, C. H. (Ed.). (1973). Chemical Engineers' Handbook (5th ed.). New York: McGraw Hill Book Co.
- Rohsenow, W. M., Hartnett, J. P., & Ganic, E. N. (Ed.). (1985). Handbook of Heat Transfer (2nd ed.). New York: McGraw Hill.
- Saha, & Srivastava (1935). Treatise On Heat. Calcutta: The Indian Press.
- Sandifer, J. B. (1992). Guidelines for Flow-Induced Vibration Prevention in Heat Exchangers. Welding Research Council Bulletin, No. 372 (May), pp. 1-27.
- Saunders, E. A. D. (1988). Heat Exchangers: Selection, Design and Construction (1st ed.). Essex: Longman Scientific & Technical.
- Shah, R. K. (1984). What's New in Heat Exchanger Design. Mechanical Engineering, 106(5), pp. 50-60.

Taborek, J. (1983). In Schlunder E.U. (Ed.), Heat Exchanger Design Handbook Washington, D.C. Hemisphere Publishing Corporation.

TEMA, T. E. M. A. (Ed.). (1988). Standards of Tubular Exchangers Manufacturers Association (7th ed.). Tarrytown. Tubular Exchanger Manufacturers Association, Inc.

Ten Broeck, H. (1938). Multipass Exchanger Calculations. Ind. Eng. Chem., 30, pp. 1041-1042.

The Patterson-Kelley Co., Inc. (1959). Heat Exchanger Manual No 7a. The Patterson-Kelley Co., Inc.

Tinker, T. (1958). Shell Side Characteristics of Shell and Tube Heat Exchangers. Trans. ASME, 80(1), pp. 36-52.

Turton, R., Ferguson, D., & Levenspiel, O. (1986). Charts for the Performance and Design of Heat Exchangers. Chem. Eng., 93 (3), pp. 81-88.

Wales, R. E. (1981). Mean Temperature Difference in Heat Exchangers. Chem. Eng., 88(4), pp. 77-81.

Walker, G. (1983). Industrial Heat Exchangers: A Basic Guide. Hemisphere Publishing Corporation, McGraw Hill Publications Co.

Walker, W. M., & Reising, G. F. S. (1968). Flow Induced Vibrations in Cross-Flow Heat Exchangers. Chemical and Process Engineering, (November), pp. 95-103.

Webb, R. L. (1987). Enhancement of Single-Phase Heat Transfer. In S. Kakac, R. K. Shah, & W. Aung (Eds.), Handbook of Single-Phase Heat Transfer. New York: John Wiley & Sons.

Webb, R. L. (1994). Principles of Enhanced Heat Transfer (1st ed.). New York: John Wiley & Sons, Inc.

APPENDICES

APPENDIX A

TYPICAL OVERALL AND INDIVIDUAL DESIGN COEFFICIENTS FOR SHELL AND TUBE HEAT EXCHANGERS

(Bell, 1993)

Given in Table A.1 are typical values of the overall heat transfer coefficients for shell and tube heat exchangers. These values can be used to estimate the heat transfer area required in a shell and tube heat exchanger. The results using these values may not be very accurate due to the fact that these values are derived to include a wide range of process conditions. As explained earlier, a more accurate method would be to estimate the overall heat transfer coefficient by estimating the individual resistances. To do so typical values of the film heat transfer coefficients are required. Table A.2 presents these values for various fluid conditions. Also given in Table A.2 are typical values of fouling resistance for various fluid conditions. These values are as those given by Bell (Bell, 1993).

Table A.1 : Typical Overall Heat Transfer Coefficients for Shell and Tube Heat Exchangers (Bell, 1993).

FLUID 1	FLUID 2	U_o W/m² K
Water (3, 4)	Water	1400-1700
Water (3,4)	Gas, about 10 psig	85-115
"	Gas, about 100 psig	170-230
"	Gas, about 1000 psig	325-575
"	Light organic liquids (5)	700-1000
"	Medium organic liquids (6)	425-700
"	Heavy organic liquids (7)	225-425
"	Very heavy organic liquids (8)	
	Heating	50-225
	Cooling	25-85
Steam	Gas, about 10 psig	85-115
"	Gas, about 100 psig	200-250
"	Gas, about 1000 psig	400-625
"	Light organic liquids (5)	750-1100
"	Medium organic liquids (6)	450-750
"	Heavy organic liquids (7)	250-450
"	Very heavy organic liquids (8)	85-250
Steam (No non- condensables)	Water	1700-2275

Table A.1 : Contd.

FLUID 1	FLUID 2	U_o W/m² K
Light organic liquids	Light organic liquids (5)	575-750
"	Medium organic liquids (6)	400-575
"	Heavy organic liquids (7)	
	Heating	225-425
	Cooling	140-285
"	Very heavy organic liquids (7)	
	Heating	115-285
	Cooling	25-140
Medium organic liquids (6)	Medium organic liquids (6)	285-450
"	Heavy organic liquids (7)	
	Heating	170-285
	Cooling	85-200
"	Very heavy organic liquids (8)	
	Heating	85-170
	Cooling	25-140
Heavy organic liquids (7)	Heavy organic liquids (7)	50-170
"	Very heavy organic liquids	25-85
Gas, about 10 psig	Gas, about 10 psig	50-85
"	Gas, about 100 psig	85-115
"	Gas, about 1000 psig	85-140
Gas, about 100 psig	Gas, about 100 psig	110-170
"	Gas, about 1000 psig	140-200
Gas, about 1000 psig	Gas, about 1000 psig	200-350

Table A.1 : Contd.

FLUID 1	FLUID 2	U _o W/m ² K
Water	Condensing light organic vapors, pure component (5,9)	850-1150
"	Condensing medium organic vapors, pure component (6,9)	550-850
"	Condensing heavy organic vapors, pure component (7,9)	425-550

1. The total fouling resistance and the overall heat transfer coefficient are based on the total outside tube area.
2. Allowable pressure drops on each side are assumed to be about 10 psi except for (a) low pressure gas and condensing vapor where the pressure drop is assumed to be about 5 % of the absolute pressure, and (b) heavy organics where the allowable pressure drop is assumed to be about 20 to 30 psi.
3. Aqueous solutions give approximately the same coefficients as water.
4. Liquid ammonia gives about the same results as water.
5. "Light organic liquids" include liquids with viscosities less than about 0.5 cp, such as hydrocarbons through C₈, gasoline, light alcohols and ketones, etc.
6. "Medium organic liquids" include liquids with viscosities between 0.5 cp and 1.5 cp, such as kerosene, straw oil, hot gas oil, absorber oil, and light crudes.
7. "Heavy organic liquids" include liquids with viscosities greater than 1.5 cp, but not over 50 cp, such as cold gas oil, lube oils, fuel oils, and heavy crudes.
8. "Very heavy organic liquids" include tars, asphalts, polymer melts, greases, etc., having liquid viscosities greater than 50 cp.

Table A.2 : Typical Film Heat Transfer Coefficients for Shell and Tube Heat Exchangers (Bell, 1993).

FLUID	CONDITIONS	α , W/m ² K ^{a,b}	FOULING RESISTANCE, W/m ² K ^a
Sensible heat transfer			
Water ^c	Liquid	5000-7500	1E-4-2.5E-4
Ammonia	Liquid	6000-8000	0-1E-4
Light organics ^d	Liquid	1500-2000	0-2E-4
Medium organics ^e	Liquid	750-1500	1E-4 -4E-4
Heavy organics ^f	Liquid		
Heating		250-750	2E-4-10E-4
Cooling		150-400	2E-4-10E-4
Very heavy organics ^g	Liquid		
Heating		100-300	4E-3-30E-3
Cooling		60-150	4E-3-30E-3
Gas ^h	Pressure 100-200 kN/m ² abs.	80-125	0-1E-4
Gas ^h	Pressure 1 MN/m ² abs.	250-400	0-1E-4
Gas ^h	Pressure 10 MN/m ² abs.	500-800	0-1E-4
Condensing heat transfer			
Steam, ammonia	Pressure 10 kN/m ² abs. no noncondensables ^{i, j}	8000-12000	0-1E-4
Steam, ammonia	Pressure 10 kN/m ² abs, 1% noncondensables ^k	4000-6000	0-1E-4
Steam, ammonia	Pressure 10 kN/m ² abs 4% noncondensables ^k	2000-3000	0-1E-4
Steam, ammonia	Pressure 100 kN/m ² abs, no noncondensables ^{i,j,k,l}	10000-15000	0-1E-4
Steam, ammonia	Pressure 1 MN/m ² abs, no noncondensables ^{i,j,k,l}	15000-25000	0-1E-4
Light organics ^d	Pure component, pressure 10 kN/m ² abs, no noncondensables ^l	1500-2000	0-1E-4
Light organics ^d	Pressure 10 kN/m ² abs 4% noncondensables ^k	750-1000	0-1E-4
Light organics ^d	Pure component, pressure 100 kN/m ² abs, no noncondensables ^l	2000-4000	0-1E-4

Table A.2 : Contd.

FLUID	CONDITIONS	α , W/m ² K ^{a,b}	FOULING RESISTANCE, W/m ² K ^a
Light organics ^d	Pure component, pressure 1 MN/m ² abs	3000-4000	0-1E-4
Medium organics ^e	Pure component or narrow condensing range, pressure 100 kN/m ² abs ^{m, n}	1500-4000	1E-4-3E-4
Heavy organics	Narrow condensing range, pressure 100 kN/m ² abs ^{m, n}	600-2000	2E-4-5E-4
Light multicomponent mixtures, all condensable ^e	Medium condensing range, pressure 100 kN/m ² abs ^{k,m,o}	1000-2500	0-2E-4
Medium multicomponent mixtures, all condensable ^e	Medium condensing range, pressure 100 kN/m ² abs ^{k,m,o}	600-1500	1E-4-4E-4
Heavy multicomponent mixtures, all condensable ^f	Medium condensing range, pressure 100 kN/m ² abs ^{k,m,o}	300-600	2E-4-8E-4
Vaporizing heat transfer^{p,q}			
Water ^r	Pressure < 0.5 MN/m ² abs, $\Delta T_{SH,max} = 25$ K	3000-10000	1E-4-2E-4
Water ^r	Pressure > 0.5 MN/m ² abs, pressure < 10 MN/m ² abs $\Delta T_{SH,max} = 20$ K	4000-15000	1E-4-2E-4
Ammonia	Pressure < 3 MN/m ² abs $\Delta T_{SH,max} = 20$ K	3000-5000	0-2E-4
Light organics ^d	Pure component, pressure < 2 MN/m ² abs, $\Delta T_{SH,max} = 20$ K	1000-4000	1E-4-2E-4
Light organics ^d	Narrow boiling ranges, Pressure < 2 MN/m ² abs, $\Delta T_{SH,max} = 15$ K	750-3000	0-2E-4
Medium organics ^e	Pure component, pressure < 2 MN/m ² abs, $\Delta T_{SH,max} = 20$ K	1000-3500	1E-4-3E-4
Medium organics ^e	Narrow boiling ranges, Pressure < 2 MN/m ² abs, $\Delta T_{SH,max} = 15$ K	600-2500	1E-4-3E-4

Table A.2: Contd.

FLUID	CONDITIONS	α , W/m ² K ^{a,b}	FOULING RESISTANCE, W/m ² K ^a
Heavy organics ^f	Pure component, pressure < 2 MN/m ² abs, $\Delta T_{SH,max} = 20K$	750-2500	2E-4-5E-4
Heavy organics ^g	Narrow boiling ranges, Pressure < 2 MN/m ² abs, $\Delta T_{SH,max} = 15 K$	400-1500	2E-4-8E-4
Very heavy organics ^h	Narrow boiling ranges, Pressure < 2 MN/m ² abs, $\Delta T_{SH,max} = 15 K$	300-1000	2E-4-10E-4

- a. Heat transfer coefficients and fouling resistances are based on area in contact with fluid. Ranges shown are typical, not all-encompassing. Temperatures are assumed to be in normal processing range; allowances should be made for very high or low temperatures.
- b. Allowable pressure drops on each side are assumed to be about 50-100 kN/m² except for (1) low-pressure gas and two-phase flows, where the pressure drop is assumed to be about 5% of the absolute pressure; and (2) very viscous organics, where the allowable pressure drop is assumed to be about 150-250 kN/m².
- c. Aqueous solutions give approximately the same coefficients as water.
- d. "Light organics" include fluids with liquid viscosities less than about 0.5×10^{-3} Ns/m², such as hydrocarbons through C8, gasoline, light alcohols and ketones, etc.
- e. "Medium organics" include fluids with liquid viscosities between about 0.5×10^{-3} Ns/m² and 2.5×10^{-3} Ns/m², such as kerosene, straw oil, hot gas oil, and light crudes.
- f. "Heavy organics" include fluids with liquid viscosities greater than 2.5×10^{-3} Ns/m², but not more than 50×10^{-3} Ns/m², such as cold gas oil, lube oils, fuel oils, and heavy and reduced crudes.
- g. "Very heavy organics" include tars, asphalts, polymer melts, greases, etc., having liquid viscosities greater than about 50×10^{-3} Ns/m². Estimation of coefficients for these

materials is very uncertain and depends strongly on the temperature difference, because natural convection is often a significant contribution to heat transfer in heating, whereas conglomeration on the surface and particularly between fins can occur in cooling. Since many of these materials are thermally unstable, high surface temperatures can lead to extremely severe fouling.

- h.** Values given for gases apply to such substances as air, nitrogen, carbon dioxide, light hydrocarbon mixtures (no condensation), etc. Because of the very high thermal conductivities and specific heats of hydrogen and helium, gas mixtures containing appreciable fractions of these components will generally have substantially higher heat transfer coefficients.
- i.** Superheat of a pure vapor is removed at the same coefficient as for condensation of the saturated vapor if the exit coolant temperature is less than the saturation temperature (at the pressure existing in the vapor phase) and if the (constant) saturation temperature is used in calculating the mean temperature difference. But see note k for vapor mixtures with or without noncondensable gas.
- j.** Steam is not to be condensed on conventional low-finned tubes; its high surface tension causes bridging and retention of the condensate and a severe reduction of the coefficient below that of the plain tube.
- k.** The coefficients cited for condensation in the presence of noncondensable gases or for multicomponent mixtures are only for very rough estimation purposes because of the presence of mass transfer resistances in the vapor (and to some extent, in the liquid) phase. Also, for these cases, the vapor-phase temperature is not constant, and the coefficient given is to be used with the mean temperature difference estimated using vapor-phase inlet and exit temperatures, together with the coolant temperatures.
- l.** As a rough approximation, the same relative reduction in low-pressure condensing coefficients due to noncondensable gases can also be applied to higher pressures.
- m.** Absolute pressure and noncondensables have about the same effect on condensing

coefficients for medium and heavy organics as for light organics. Because of prior thermal degradation, fouling may become quite severe for the heavier condensates. For large fractions of noncondensable gas, interpolate between pure component condensation and gas cooling coefficients.

- n. "Narrow condensing range" implies that the temperature difference between dew point and bubble point is less than the smallest temperature difference between vapor and coolant at any place in the condenser.
- o. "Medium condensing range" implies that the temperature difference between dew point and bubble point is greater than the smallest temperature difference between vapor and coolant, but less than the temperature difference between inlet vapor and outlet coolant.
- p. Boiling and vaporizing heat transfer coefficients depend very strongly on the nature of the surface and the structure of the two-phase flow past the surface in addition to all of the other variables that are significant for convective heat transfer in other modes. The flow velocity and structure are very much governed by the geometry of the equipment and its connecting piping. Also, there is a maximum heat flux from the surface that can be achieved with reasonable temperature differences between surface and saturation temperatures of the boiling fluid; any attempt to exceed this maximum heat flux by increasing the surface temperature leads to partial or total coverage of the surface by film of vapor and a sharp decrease in the heat flux. Therefore, the vaporizing heat transfer coefficients given in this table are only for very rough estimating purposes and assume the use of plain or low-finned tubes without special nucleation enhancement. $\Delta T_{SH,max}$ is the maximum allowable temperature difference between surface and saturation temperature of the boiling liquid.

No attempt is made in this table to distinguish among the various types of vapor-generation equipment, since the major heat transfer distinction to be made is propensity of the process stream to foul. Severely fouling streams will usually call for a vertical thermosiphon or a forced convection (tube-side) reboiler for ease of cleaning.

- q. Subcooling heat load is transferred at the same coefficient as latent heat load in kettle

reboilers, using the saturation temperature in the mean temperature difference. For horizontal and vertical thermosiphons, a separate calculation is required for the sensible heat transfer area, using appropriate sensible heat transfer coefficients and the liquid temperature profile for the mean temperature difference.

- r. Aqueous solutions vaporize with nearly the same coefficient as pure water is attention is given to boiling-point evaluation, if the solution does not become saturated, and if care is taken to avoid dry wall conditions.
- s. For boiling of mixtures, the saturation temperature (bubble point) of the final liquid phase (after the desired vaporization has taken place) is to be used to calculate the mean temperature difference. A narrow-boiling-range mixture is defined as one for which the difference between the bubble point of the incoming liquid and the bubble point of the exit liquid is less than the temperature difference between the exit hot stream and the bubble point of the exit boiling liquid. Wide-boiling-range mixtures require a case-by-case analysis and cannot be reliably estimated by these simple procedures.

APPENDIX B

EXAMPLE PROBLEM

Problem Statement

A shell and tube heat exchanger is cooling a low pressure gas ($0.45 \text{ MN/m}^2 \text{ abs.}$) from 376 K to 319 K , heating water from 300 K to 311 K . The gas flow rate is 86.55 kg/s , with a specific heat of 2311 J/kg K and the water flow rate is 246.64 kg/s with a specific heat of 4179 J/kg K .

A split backing ring floating head type exchanger is to be used with water in the tubes. The tubes are Wolverine Type S/T Trufin[®], No. 60-195083 (19.05 mm. outside diameter) on 25.4 mm. square pitch. The material of construction is 90-10 Cupronickel (Alloy C70600), which has a thermal conductivity of 52 W/m K .

The specifications of the finned tubes are:

19 fins per inch (748 fins/m)

Outside diameter (over fins) : 19.05 mm. (0.75 in.)

Wall thickness (under fins) : 2.11 mm (0.083 in.)

Inside diameter (under fins) : 11.61 mm (0.457 in.)

Total external surface area per unit length : $0.151 \text{ m}^2/\text{m}$ ($0.496 \text{ ft}^2/\text{ft}$)

Surface area ratio, external to internal : 4.14

Typical pressure drops allowable are 3 kPa and 86 kPa for the shell- and tube-side respectively. Fouling resistances are given as 0.00035 m K/W for either side.

Estimate the effective tube length and shell inside diameter of the exchanger for this service.

Solution:

Check the Heat Balance

$$\begin{aligned} Q_{\text{gas}} &= 86.55(2311)(376 - 319) \\ &= 1.14 \times 10^7 \text{ W} \end{aligned}$$

$$\begin{aligned} Q_{\text{water}} &= 246.64(4179)(311 - 300) \\ &= 1.13 \times 10^7 \text{ W} \end{aligned}$$

Mean Temperature Difference

We first estimate the LMTD by calculating the AMTD.

$$\begin{aligned} \text{AMTD} &= \frac{1}{2} \{ (376 - 311) + (319 - 300) \} \\ &= 42 \text{ K} \end{aligned}$$

Since the ratio of the smaller terminal temperature difference to the larger is quite low, the difference between the AMTD and the LMTD is quite low also. Hence, we estimate that the LMTD value is approximately 90% of the AMTD.

$$\text{LMTD} = 0.9 \times 42 = 37.8 \text{ K}$$

Since the temperatures of the outlet streams are not equal and neither stream is isothermal, we estimate the value of the LMTD correction factor to be approximately between 0.8 and 1.0. We estimate this value to be 0.9, i.e.,

$$F_T = 0.9$$

Therefore, $MTD = 0.9 \times 37.8 = 34.0 \text{ K}$

Estimation of Overall Heat Transfer Coefficient, U_o

Gas : $\alpha_o = 400 \text{ W/m}^2 \text{ K}$ (from Appendix A, Table A.2)

$$R_{fo} = 0.00035 \text{ m}^2 \text{ K/W}$$

Water : $\alpha_i = 7000 \text{ W/m}^2 \text{ K}$ (from Appendix A, Table A.2)

$$R_{fi} = 0.00035 \text{ m}^2 \text{ K/W}$$

Fin Efficiency

This value can be calculated using equation (2.7) or can be estimated. We know that the thermal conductivity of the fin material (90-10 Cupronickel) is quite high (52 W/m K). Also, the fin height is low, i.e., it is a low finned tube. The heat transfer coefficient on the shell side is quite low (400 W/m² K). Hence, the fin efficiency for this case can be assumed to be high. As explained earlier, the fin efficiency lies between 0.95 and 1.0 for not very severe operating conditions. We estimate this value to be 0.98 for the case at hand.

We now calculate the wall resistance.

$$\Delta x = \frac{1}{2}(d_r - d_i) = \frac{1}{2}(15.875 - 11.61)$$

$$= 2.133 \text{ mm}$$

$$A_m \approx \pi(d_i + \Delta x)L$$

$$\approx \pi(11.61 + 2.133)$$

$$\approx 43.2 \text{ (mm}^2 \text{ / mm length)}$$

Hence,

$$R_{\text{wall}} = \frac{\Delta x_w A_o}{k_w A_m} = \frac{2.133 \text{ (mm)} \cdot 0.151 \text{ (m}^2/\text{m)}}{52 \text{ (W/m K)} \cdot 43.2 \text{ (mm}^2/\text{mm)}}$$

$$= 1.43 \times 10^{-4} \text{ m}^2 \text{ K/W}$$

We now estimate the value of U_o using equation (2.15)

$$U_o = \frac{1}{\frac{0.151}{7000(0.0365)} + 0.00035 \frac{0.151}{0.0365} + 1.43 \times 10^{-4} + \frac{0.00035}{0.98} + \frac{1}{400(0.98)}}$$

$$\approx 200 \text{ W/m}^2 \text{ K}$$

Calculation of the Required Area

$$A_o = \frac{1.14 \times 10^7}{200(33.7)} = 1690 \text{ m}^2$$

This is the actual area required in the exchanger. However, in order to use figure (2.11), it is necessary to use equation (2.29) and the associated tables to find the equivalent area, A'_o .

Calculation of the Equivalent Area

From Table 3.1, for 19.05 mm. OD tubes on 25.4 mm. square pitch,

$$F_1 = 1.307$$

From Table 3.2, for 2 tube-side passes and assuming a shell diameter of about 1 m.,

$$F_2 = 1.018$$

From Table 3.3, for split backing ring type of exchanger, and a shell diameter of about 1 m.,

$$F_3 = 1.06$$

From Table 3.4, for 748 fins/m (19 fins/in.), 19.05 mm. OD tubes,

$$F_f = 0.392$$

Therefore,

$$\begin{aligned} A'_o &= 1690 \times 1.307 \times 1.018 \times 1.06 \times 0.392 \\ &= 920 \text{ m}^2 \end{aligned}$$

From figure (2.11), for $A'_o \cong 920 \text{ m}^2$,

the following combinations of L vs. D_i are obtained:

L m.	D_i m.	L/ D_i
5.0	1.372	3.6
6.5	1.219	5.3
7.9	1.143	6.6
9.2	1.067	8.6
9.8	0.991	9.9

As seen in the above table, the first two L- D_i combinations need not be considered to avoid operational problems. A good choice appears to be 1.067 m. inside diameter shell and 9.2 m. effective tube length. Although the L/ D_i ratio is on the higher

side, detailed analysis may prove to give results within all prescribed limits. These may include space constraints, pressure drop limitations, vibration limitations.

Calculation of the Area Provided

We now check whether the chosen configuration will provide the required heat transfer area.

From Appendix E, for split-ring floating head exchanger, 1.067 m. shell inside diameter and two tube-side passes:

$$N_t = 1223$$

Hence, the heat transfer area provided is:

$$\begin{aligned} A_o &= 0.151 \text{ (m}^2 \text{ / m)} \times 9.2 \text{ (m)} \times 1223 \\ &= 1700 \text{ m}^2 \end{aligned}$$

Thus, the area provided by the chosen configuration is greater than that required and the design is satisfactory in this respect.

Tube-side Velocity

Number of tubes per pass = 612

$$\text{Internal flow area of one tube} = \frac{\pi}{4} \times (0.1161)^2 = 1.059 \times 10^{-4} \text{ m}^2$$

$$\text{Internal flow area of one pass} = 612 \times 1.059 \times 10^{-4} = 0.065 \text{ m}^2$$

$$\text{Hence, velocity in tubes} = \frac{246.64 \text{ (kg / s)}}{997 \text{ (kg / m}^3) \times 0.065 \text{ (m}^2)} = 3.81 \text{ m / s}$$

The calculated velocity of water in the tubes seems to be a little on the higher side for Cupronickel tubes.

We provide single segmental baffles for this configuration.

Two pairs of sealing strips would probably be adequate. .

Provide a 25% baffle cut.

Minimum baffle spacing as per TEMA = $0.2 (1.067) = 0.215 \text{ m.} = 8.5 \text{ inches}$

We provide a central baffle spacing of 0.375 m.

APPENDIX C

CHARACTERISTICS OF TUBING (TEMA, 1988)

Tube O.D. Inches	B.W.G. Gage	Thickness Inches	Internal Area Sq. Inch	Sq. Ft. External Surface Per Foot Length	Sq. Ft. Internal Surface Per Foot Length	Weight Per Ft. Length Steel Lbs.*	Tube I.D. Inches	Moment of Inertia Incher ⁴	Section Modulus Incher ³	Radius of Gyration Inches	Constant C**	O.D. I.D.	Transverse Metal Area Sq. Inch
1/4	22	0.028	0.0296	0.0654	0.0508	0.066	0.194	0.00012	0.00098	0.0791	46	1.289	0.0195
	24	0.022	0.0333	0.0654	0.0539	0.054	0.208	0.00010	0.00083	0.0810	52	1.214	0.0158
	26	0.018	0.0360	0.0654	0.0560	0.045	0.214	0.00009	0.00071	0.0823	56	1.168	0.0131
	27	0.016	0.0373	0.0654	0.0571	0.040	0.218	0.00008	0.00065	0.0829	58	1.147	0.0118
3/8	18	0.049	0.0603	0.0982	0.0725	0.171	0.277	0.00068	0.0036	0.1166	94	1.354	0.0502
	20	0.035	0.0731	0.0982	0.0798	0.127	0.305	0.00055	0.0029	0.1208	114	1.230	0.0374
	22	0.028	0.0789	0.0982	0.0835	0.104	0.319	0.00048	0.0025	0.1231	125	1.178	0.0305
	24	0.022	0.0860	0.0982	0.0867	0.083	0.330	0.00038	0.0020	0.1250	134	1.133	0.0244
1/2	16	0.065	0.1075	0.1309	0.0969	0.302	0.370	0.0021	0.0086	0.1555	168	1.351	0.0888
	18	0.049	0.1269	0.1309	0.1052	0.236	0.402	0.0018	0.0071	0.1604	198	1.244	0.0694
	20	0.035	0.1452	0.1309	0.1128	0.174	0.430	0.0014	0.0058	0.1649	227	1.163	0.0511
	22	0.028	0.1548	0.1309	0.1162	0.141	0.444	0.0012	0.0046	0.1672	241	1.126	0.0415
5/8	12	0.109	0.1301	0.1636	0.1066	0.601	0.407	0.0081	0.0197	0.1865	203	1.536	0.177
	13	0.095	0.1486	0.1636	0.1139	0.538	0.435	0.0057	0.0183	0.1904	232	1.437	0.158
	14	0.083	0.1655	0.1636	0.1202	0.481	0.459	0.0053	0.0170	0.1939	258	1.362	0.141
	15	0.072	0.1817	0.1636	0.1259	0.428	0.481	0.0049	0.0158	0.1972	283	1.299	0.125
	16	0.065	0.1924	0.1636	0.1298	0.389	0.488	0.0045	0.0145	0.1993	300	1.253	0.114
	17	0.058	0.2035	0.1636	0.1333	0.352	0.509	0.0042	0.0134	0.2015	317	1.228	0.103
	18	0.049	0.2181	0.1636	0.1380	0.302	0.527	0.0037	0.0119	0.2044	340	1.188	0.089
	19	0.042	0.2299	0.1636	0.1416	0.262	0.541	0.0033	0.0105	0.2067	359	1.155	0.077
	20	0.035	0.2419	0.1636	0.1453	0.221	0.555	0.0028	0.0091	0.2090	377	1.126	0.065
	3/4	10	0.134	0.1825	0.1983	0.1262	0.833	0.482	0.0129	0.0344	0.2229	285	1.556
11		0.120	0.2043	0.1983	0.1335	0.808	0.510	0.0122	0.0326	0.2267	319	1.471	0.238
12		0.109	0.2223	0.1983	0.1383	0.747	0.532	0.0118	0.0309	0.2299	347	1.410	0.219
13		0.095	0.2463	0.1983	0.1468	0.685	0.560	0.0107	0.0285	0.2340	384	1.339	0.195
14		0.083	0.2679	0.1983	0.1529	0.592	0.584	0.0098	0.0262	0.2378	418	1.284	0.174
15		0.072	0.2884	0.1983	0.1587	0.522	0.608	0.0089	0.0239	0.2411	450	1.238	0.153
16		0.065	0.3019	0.1983	0.1623	0.478	0.620	0.0083	0.0221	0.2433	471	1.210	0.140
17		0.058	0.3157	0.1983	0.1660	0.429	0.634	0.0078	0.0203	0.2455	492	1.183	0.128
18		0.049	0.3339	0.1983	0.1707	0.367	0.652	0.0067	0.0178	0.2484	521	1.150	0.108
20		0.035	0.3632	0.1983	0.1780	0.268	0.680	0.0050	0.0154	0.2531	567	1.103	0.079
7/8	10	0.134	0.2894	0.2291	0.1589	1.062	0.607	0.0221	0.0505	0.2562	451	1.442	0.312
	11	0.120	0.3167	0.2291	0.1662	0.969	0.635	0.0208	0.0475	0.2703	494	1.378	0.285
	12	0.109	0.3390	0.2291	0.1720	0.893	0.657	0.0198	0.0449	0.2736	529	1.332	0.262
	13	0.095	0.3685	0.2291	0.1793	0.792	0.685	0.0180	0.0411	0.2778	575	1.277	0.233
	14	0.083	0.3948	0.2291	0.1858	0.703	0.709	0.0164	0.0374	0.2815	616	1.234	0.207
	15	0.072	0.4187	0.2291	0.1914	0.618	0.731	0.0148	0.0337	0.2850	655	1.197	0.182
	16	0.065	0.4359	0.2291	0.1950	0.569	0.745	0.0137	0.0312	0.2873	690	1.174	0.165
	17	0.058	0.4525	0.2291	0.1987	0.507	0.758	0.0125	0.0285	0.2896	708	1.153	0.149
	18	0.049	0.4742	0.2291	0.2034	0.433	0.777	0.0109	0.0249	0.2925	740	1.128	0.127
	20	0.035	0.5090	0.2291	0.2107	0.314	0.805	0.0082	0.0187	0.2972	794	1.087	0.092
1	8	0.185	0.3526	0.2618	0.1754	1.473	0.670	0.0392	0.0784	0.3009	550	1.493	0.433
	10	0.134	0.4208	0.2618	0.1916	1.241	0.732	0.0350	0.0700	0.3098	656	1.366	0.365
	11	0.120	0.4536	0.2618	0.1990	1.129	0.760	0.0327	0.0654	0.3140	708	1.316	0.332
	12	0.109	0.4803	0.2618	0.2047	1.038	0.782	0.0307	0.0615	0.3174	749	1.279	0.305
	13	0.095	0.5153	0.2618	0.2121	0.919	0.810	0.0280	0.0559	0.3217	804	1.235	0.270
	14	0.083	0.5463	0.2618	0.2183	0.814	0.834	0.0253	0.0507	0.3265	852	1.199	0.239
	15	0.072	0.5755	0.2618	0.2241	0.714	0.858	0.0227	0.0455	0.3291	898	1.168	0.210
	16	0.065	0.5945	0.2618	0.2278	0.650	0.870	0.0210	0.0419	0.3314	927	1.149	0.191
	18	0.049	0.6390	0.2618	0.2361	0.498	0.902	0.0168	0.0332	0.3367	997	1.109	0.148
	20	0.035	0.6793	0.2618	0.2435	0.361	0.930	0.0124	0.0247	0.3414	1060	1.075	0.106
1-1/4	7	0.180	0.6221	0.3272	0.2330	2.059	0.890	0.0890	0.1425	0.3836	970	1.404	0.605
	8	0.165	0.6648	0.3272	0.2409	1.914	0.920	0.0847	0.1355	0.3880	1037	1.359	0.562
	10	0.134	0.7574	0.3272	0.2571	1.599	0.982	0.0742	0.1187	0.3974	1182	1.273	0.470
	11	0.120	0.8012	0.3272	0.2644	1.450	1.010	0.0688	0.1100	0.4018	1250	1.238	0.428
	12	0.109	0.8365	0.3272	0.2702	1.300	1.032	0.0642	0.1027	0.4052	1305	1.211	0.391
	13	0.095	0.8825	0.3272	0.2775	1.173	1.060	0.0579	0.0926	0.4097	1377	1.179	0.345
	14	0.083	0.9229	0.3272	0.2838	1.036	1.084	0.0521	0.0833	0.4136	1440	1.153	0.304
	16	0.065	0.9852	0.3272	0.2932	0.824	1.120	0.0426	0.0682	0.4196	1537	1.118	0.242
	18	0.049	1.0423	0.3272	0.3018	0.629	1.152	0.0334	0.0534	0.4250	1626	1.085	0.185
	20	0.035	1.0936	0.3272	0.3089	0.455	1.180	0.0247	0.0395	0.4297	1708	1.059	0.134
1-1/2	10	0.134	1.1921	0.3927	0.3225	1.957	1.232	0.1354	0.1806	0.4853	1880	1.218	0.575
	12	0.109	1.2908	0.3927	0.3356	1.621	1.282	0.1159	0.1545	0.4933	2014	1.170	0.478
	14	0.083	1.3977	0.3927	0.3492	1.257	1.334	0.0931	0.1241	0.5018	2180	1.124	0.369
	16	0.065	1.4741	0.3927	0.3587	0.997	1.370	0.0758	0.1008	0.5079	2300	1.095	0.293
2	11	0.120	2.4328	0.5236	0.4808	2.412	1.760	0.3144	0.3144	0.6660	3795	1.136	0.709
	12	0.109	2.4941	0.5236	0.4865	2.204	1.782	0.2904	0.2904	0.6997	3891	1.122	0.648
	13	0.095	2.5730	0.5236	0.4759	1.935	1.810	0.2598	0.2598	0.7444	4014	1.105	0.568
	14	0.083	2.6417	0.5236	0.4801	1.701	1.834	0.2300	0.2300	0.7884	4121	1.091	0.500

* Weights are based on low carbon steel with a density of 0.2836 lbs./cu. in. For other metals multiply by the following factors:

Aluminum	0.35	Aluminum Bronze	1.04	Nickel	1.13
Titanium	0.58	Aluminum Brass	1.06	Nickel-Copper	1.12
A.I.S.I. 400 Series S/Steels	0.99	Nickel-Chrome-Iron	1.07	Copper and Cupro-Nickels	1.14
A.I.S.I. 300 Series S/Steels	1.02	Admiralty	1.09		

** Liquid Velocity = $\frac{\text{lbs. Per Tube Hour}}{C \times \text{Sp. Gr. of Liquid}}$ in feet per sec. (Sp. Gr. of Water at 60°F. = 1.0)

APPENDIX D

DATA FOR FINNED TUBES (Wolverine Tube, Inc.)

STANDARD SIZES - TYPE S/T TRUFIN
19 Fins Per Inch (25.4 millimeters)

Standard Sizes			Plain Section Dimensions and Tolerances						
Out- side Dia.	Wall Thk. (X ₁)	Catalog Number	Outside Diameter (d)			Wall Thickness (X ₂)			
			Nom. Size		Tolerances in. (mm)	Nominal Size		Tolerances in. (mm)	
			in.	mm.	B359 & B404	in.	mm	B359	B404
3/8	.037	60-192037	.375	9.5	.0020 (.051)	.048	1.22	.0030 (.076)	---
1/2	.032	60-193032	.500	13.0	.0020 (.051)	.049	1.25	.0030 (.076)	.0045 (.11)
	.042	60-193042				.058	1.47	.0035 (.089)	.0050 (.13)
	.049	60-193049				.065	1.65	.0035 (.089)	.0060 (.15)
	.058	60-193058				.075	1.91	.0035 (.089)	.0065 (.16)
5/8	.028	60-194028	.625	15.9	.0025 (.064)	.042	1.07	.0030 (.076)	.0040 (.10)
	.035	60-194035				.049	1.25	.0030 (.076)	.0045 (.11)
	.042	60-194042				.058	1.47	.0035 (.089)	.0050 (.13)
	.049	60-194049				.065	1.65	.0035 (.089)	.0060 (.15)
	.058	60-194058				.072	1.83	.0035 (.089)	.0065 (.16)
	.065	60-194065				.083	2.11	.0040 (.10)	.0075 (.19)
3/4	.072	60-194072	.750	19.1	.0030 (.076)	.086	2.18	.0040 (.10)	.0080 (.20)
	.028	60-195028				.049	1.25	.0035 (.089)	.0045 (.11)
	.035	60-195035				.052	1.32	.0035 (.089)	.0045 (.11)
	.042	60-195042				.058	1.47	.0040 (.10)	.0050 (.13)
	.049	60-195049				.065	1.65	.0040 (.10)	.0060 (.15)
	.058	60-195058				.075	1.91	.0040 (.10)	.0065 (.16)
	.065	60-195065				.083	2.11	.0050 (.13)	.0075 (.19)
	.072	60-195072				.086	2.18	.0050 (.13)	.0080 (.20)
7/8	.083	60-195083	.875	22.2	.0030 (.076)	.095	2.41	.0050 (.13)	.0085 (.22)
	.095	60-195095				.109	2.77	.0050 (.13)	.0100 (.25)
	.109	60-195109				.121	3.07	.0050 (.13)	.0110 (.28)
	.035	60-196035				.054	1.37	.0035 (.089)	.0050 (.13)
	.042	60-196042				.058	1.47	.0040 (.10)	.0050 (.13)
	.049	60-196049				.065	1.65	.0040 (.10)	.0060 (.15)
	.058	60-196058				.075	1.91	.0050 (.13)	.0065 (.16)
1	.065	60-196065	1.000	25.4	.0030 (.076)	.083	2.11	.0050 (.13)	.0075 (.19)
	.072	60-196072				.086	2.18	.0050 (.13)	.0080 (.20)
	.083	60-196083				.095	2.41	.0050 (.13)	.0085 (.22)
	.095	60-196095				.109	2.77	.0050 (.13)	.0100 (.25)
	.042	60-197042				.058	1.47	.0040 (.10)	.0050 (.13)
	.049	60-197049				.065	1.65	.0040 (.10)	.0060 (.15)
	.058	60-197058				.076	1.93	.0040 (.10)	.0070 (.18)
	.065	60-197065				.083	2.11	.0050 (.13)	.0075 (.19)
	.072	60-197072				.086	2.18	.0050 (.13)	.0080 (.20)
	.083	60-197083				.095	2.41	.0050 (.13)	.0085 (.22)
	.095	60-197095				.109	2.77	---	.0100 (.25)
	.109	60-197109				.120	3.05	---	.0110 (.28)

Fins per inch - 19 + 1, -0
 Fin width - .011 inch avg.
 Fin height - .050 inch min.
 - .056 inch avg.

Tolerances are plus or minus

TABLE 1

Catalog Number	Fin Section Dimensions				Available Alloys See Table 3
	At-A-Point Root Diameter (d _r)		Minimum Wall Thickness		
	in.	mm	in.	mm	
60-192037	.250	6.4	.033	.84	01,02,26,41,53,55
60-193032	.375	9.5	.028	.71	01,02,41,53,55
60-193042			.037	.94	} { 01,02,26,28 41,51,53,55
60-193049			.044	1.12	
60-193058			.053	1.35	
60-194028	.500	13.0	.025	.64	} { 01,02,41 53,55
60-194035			.031	.79	
60-194042			.037	.94	
60-194049			.044	1.12	} All Alloys
60-194058			.051	1.30	
60-194065			.058	1.47	
60-194072			.066	1.68	
60-195028	.625	15.9	.025	.64	} { 01,02,41 53,55
60-195035			.031	.79	
60-195042			.037	.94	
60-195049			.044	1.12	} All Alloys
60-195058			.049	1.25	
60-195065			.058	1.47	
60-195072			.065	1.65	
60-195083			.074	1.88	
60-195095			.084	2.13	
60-195109			.095	2.41	
60-196035	.750	19.1	.031	.79	} { 01,02,41 53,55
60-196042			.037	.94	
60-196049			.044	1.12	
60-196058			.049	1.25	} All Alloys
60-196065			.058	1.47	
60-196072			.065	1.65	
60-196083			.074	1.88	
60-196095			.084	2.13	
60-197042	.875	22.2	.037	.94	} { 01,02,41, 53,55
60-197049			.044	1.12	
60-197058			.049	1.25	
60-197065			.058	1.47	} All Alloys
60-197072			.065	1.65	
60-197083			.074	1.88	
60-197095			.084	2.13	
60-197109			.097	2.46	

Root diameter tolerance is +.007 in. (.18mm), -.003 in. (.07mm) at a point with exception of 60-195049 and all Trufin of Alloys 26 and 30. These products are produced to a tolerance of +.015 in. (.38mm), -.003 in. (.07mm) at a point.

ENGINEERING DATA - TYPE S/T TRUFIN
19 Fins Per Inch (25.4 millimeters)

TABLE 2

Catalog Number	Average Outside Area		Surface Area Ratio To (Outside)	I.D. Cross Section Area-Average		Approx. Weight (Copper)	
	ft ² /ft	cm ² /cm		in ²	cm ²	lbs/ft	kgs/m
60-192037	.225	6.85	4.80	.025	.016	.164	.244
60-193032	.318	9.69	3.86	.077	.050	.230	.342
60-193042	.318	9.69	4.13	.068	.049	.267	.397
60-193049	.318	9.69	4.33	.062	.040	.291	.433
60-193058	.318	9.69	4.63	.054	.035	.320	.476
60-194028	.410	12.49	3.51	.157	1.01	.283	.421
60-194035	.410	12.49	3.62	.147	.95	.320	.476
60-194042	.410	12.49	3.74	.138	.89	.356	.530
60-194049	.410	12.49	3.87	.129	.83	.391	.581
60-194058	.410	12.49	4.05	.118	.76	.435	.647
60-194065	.410	12.49	4.20	.109	.70	.466	.693
60-194072	.410	12.49	4.36	.101	.65	.500	.744
60-195028	.501	15.27	3.34	.257	1.66	.334	.497
60-195035	.501	15.27	3.43	.245	1.58	.401	.597
60-195042	.501	15.27	3.52	.232	1.50	.448	.667
60-195049	.503	15.33	3.62	.221	1.43	.493	.734
60-195058	.503	15.33	3.75	.206	1.33	.550	.818
60-195065	.503	15.33	3.86	.195	1.26	.593	.882
60-195072	.503	15.33	3.97	.184	1.19	.635	.945
60-195083	.503	15.33	4.16	.168	1.08	.697	1.037
60-195095	.503	15.33	4.38	.151	.97	.765	1.138
60-195109	.503	15.33	4.68	.132	.85	.835	1.242
60-196035	.595	18.13	3.33	.366	2.36	.485	.722
60-196042	.595	18.13	3.40	.352	2.27	.541	.805
60-196049	.595	18.13	3.47	.337	2.17	.597	.888
60-196058	.595	18.13	3.57	.319	2.06	.665	.990
60-196065	.595	18.13	3.65	.305	1.97	.721	1.073
60-196072	.595	18.13	3.73	.291	1.88	.770	1.146
60-196083	.595	18.13	3.87	.271	1.75	.853	1.269
60-196095	.595	18.13	4.04	.249	1.61	.935	1.391
60-197042	.688	20.97	3.31	.495	3.19	.632	.940
60-197049	.688	20.97	3.37	.478	3.08	.699	1.040
60-197058	.688	20.97	3.45	.456	2.94	.780	1.161
60-197065	.688	20.97	3.51	.439	2.83	.847	1.260
60-197072	.688	20.97	3.58	.423	2.72	.910	1.354
60-197083	.688	20.97	3.69	.398	2.57	1.006	1.497
60-197095	.688	20.97	3.82	.372	2.40	1.106	1.646
60-197109	.688	20.97	3.98	.342	2.21	1.215	1.808

ALLOYS - APPLICABLE PLAIN TUBE SPECIFICATIONS AND MECHANICAL PROPERTIES

TABLE 3

Wolv. Alloy Number	UNS Number	ASTM Spec Number	Tensile Strength Minimum		Yield Strength Minimum		Temper
			KSI	MPa	KSI	MPa	
01	C12200	B359	30	205	9	62	Annealed Lt. Drawn
			36	250	30	205	
02	C14200	B359	30	205	9	62	Annealed Lt. Drawn
			36	250	30	205	
26	C44300	B359	45	310	15	105	Annealed
28	C23000	B359	40	275	12	85	Annealed
30	C68700	B359	50	345	18	125	Annealed
32	C60800	B359	50	345	19	130	Annealed
41	A93003	B404	14	97	5	35	Annealed
51	C71500	B359	52	360	18	125	Annealed
53	C70600	B359	40	275	15	105	Annealed Lt. Drawn
			45	310	35	245	
55	C70400	B359	38	265	12	85	Annealed Lt. Drawn
			40	275	30	205	
58	C71000	B359	45	310	16	110	Annealed

* For equivalent ASME spec., mechanical property data is identical.

APPENDIX E

TUBE COUNTS FOR VARIOUS EXCHANGER CONFIGURATIONS (Saunders, 1988)

The tube count tables for the various shell and tube heat exchangers presented here are taken from Saunders (1988). They are for tubes 19.05 mm outside diameter on a 23.81 mm triangular pitch layout.

In the following tables, the following nomenclature is used

- D_i Shell inside diameter
- D_{otl} Diameter of outer tube limit
- d_o Tube outside diameter

Table E.1 : Tube Count for Fixed Tubesheet Exchangers.

The following data is for

$$d_o = 19.05 \text{ mm}$$

Pitch = 23.81 mm Triangular

Pitch Ratio = 1.25

D_i	Number of Tubes				D_{otl}
	1 Pass	2 Pass	4 Pass	6 Pass	
mm.					mm.
203	52	45	32	26	190
254	85	76	60	52	241
305	127	116	98	88	292
337	158	146	125	115	322
387	213	199	175	163	371
438	276	260	234	220	422
489	348	330	301	285	473
540	428	408	376	359	524
591	516	495	459	440	574
635	600	577	539	518	618
686	704	679	638	616	669
737	816	789	745	721	720
787	936	907	860	835	769
838	1064	1034	983	956	820
889	1201	1169	1115	1087	871
940	1346	1312	1255	1226	922
991	1499	1463	1403	1372	972
1067	1745	1706	1642	1608	1048
1143	2009	1968	1898	1862	1124
1219	2291	2247	2173	2134	1200
1295	2592	2545	2467	2425	1275
1372	2912	2862	2779	2735	1352
1448	3250	3198	3110	3064	1428
1524	3607	3552	3459	3411	1503

Table E.2 : Tube Count for Split Backing Ring Floating Head Exchangers.

The following data is for

$d_o = 19.05 \text{ mm}$

Pitch = 23.81 mm Triangular

Pitch Ratio = 1.25

D_i	Number of Tubes				D_{otl}
	1 Pass	2 Pass	4 Pass	6 Pass	
mm					mm
203	40	33	20	14	175.0
254	70	61	45	37	226.0
305	108	97	79	69	277.0
337	136	124	103	93	305.5
387	188	174	150	138	354.5
438	247	231	205	191	405.5
489	315	297	268	252	456.5
540	392	372	340	323	505.5
591	477	456	420	401	556.0
635	545	522	484	463	600.0
686	644	619	578	556	651.0
737	752	725	681	657	699.5
787	867	838	791	766	748.0
838	991	961	910	883	799.0
889	1123	1091	1037	1009	850.0
940	1264	1230	1173	1144	899.0
991	1407	1371	1311	1280	948.0
1067	1645	1606	1542	1508	1024.0
1143	1902	1861	1791	1755	1100.0
1219	2177	2133	2059	2020	1173.0
1295	2471	2424	2346	2304	1248.0
1372	2783	2733	2650	2606	1325.0
1448	3114	3062	2974	2928	1400.0
1524	3463	3408	3315	3267	1472.0

Table E.3 : Tube Count for U-Tube Exchangers.

The following data is for

$d_o = 19.05$ mm

Pitch = 23.81 mm Triangular

Pitch Ratio = 1.25

D_i	Number of Tubes			D_{otl}
	2 Pass	4 Pass	6 Pass	
mm	2 Pass	4 Pass	6 Pass	mm
203	36	28	26	190
254	64	56	52	241
305	104	92	84	292
337	132	120	112	322
387	182	168	156	371
438	242	226	206	422
489	310	292	274	473
540	386	366	348	524
591	470	448	428	574
635	550	528	502	618
686	650	626	596	669
737	758	732	704	720
787	874	846	814	769
838	1000	968	944	820
889	1132	1098	1046	871
940	1272	1238	1190	922
991	1422	1384	1338	972
1067	1662	1622	1578	1048
1143	1922	1878	1828	1124
1219	2206	2152	2104	1200
1295	2492	2444	2400	1275
1372	2806	2756	2704	1352
1448	3138	3086	3036	1428
1524	3488	3434	3380	1503

Table E.4 : Tube Count for Pull-through Floating Head Exchangers.
 Pressure = 1000 KPa.

The following data is for

$d_o = 19.05$ mm

Pitch = 23.81 mm Triangular

Pitch Ratio = 1.25

D_i	Number of Tubes				D_{otl}
	1 Pass	2 Pass	4 Pass	6 Pass	
203	15	13	8	5	116
254	36	29	18	12	166
305	63	55	41	34	216
337	84	76	62	54	247
387	127	116	96	87	296
438	179	165	142	131	346
489	235	220	195	182	396
540	300	283	255	240	446
591	377	358	327	311	496
635	447	428	394	376	539
686	525	502	466	446	589
737	620	596	556	535	639
787	727	701	658	635	688
838	843	815	769	745	738
889	963	934	885	858	788
940	1091	1060	1007	980	838
991	1233	1199	1144	1116	888
1067	1450	1413	1351	1319	962
1143	1685	1645	1579	1544	1036
1219	1930	1889	1818	1781	1108
1295	2203	2159	2084	2045	1180
1372	2499	2452	2373	2330	1255
1448	2796	2746	2662	2618	1328
1524	3123	3071	2983	2936	1402

Table E.5 : Tube Count for Pull-through Floating Head Exchangers.
 Pressure = 2000 KPa

The following data is for

$d_o = 19.05$ mm

Pitch = 23.81 mm Triangular

Pitch Ratio = 1.25

D_i	Number of Tubes				D_{otl}
	1 Pass	2 Pass	4 Pass	6 Pass	
203	40	33	20	14	113
254	70	61	45	37	163
305	108	97	79	69	213
337	136	124	103	93	243
387	188	174	150	138	291
438	247	231	205	191	340
489	315	297	268	252	389
540	392	372	340	323	438
591	477	456	420	401	487
635	545	522	484	463	529
686	644	619	578	556	578
737	752	725	681	657	627
787	867	838	791	766	674
838	991	961	910	883	723
889	1123	1091	1037	1009	772
940	1264	1230	1173	1144	821
991	1407	1371	1311	1280	871
1067	1645	1606	1542	1508	945
1143	1902	1861	1791	1755	1018
1219	2177	2133	2059	2020	1091
1295	2471	2424	2346	2304	1163
1372	2783	2733	2650	2606	1236
1448	3114	3062	2974	2928	1308
1524	3463	3408	3315	3267	1380

APPENDIX F

CALCULATIONS FOR CORRECTION FACTOR F_1

The correction factor for a unit cell tube array is defined as:

$$F_1 = \frac{(\text{Heat transfer area / Cross-sectional area of a unit cell})_{\text{ref.}}}{(\text{Heat transfer area / Cross-sectional area of a unit cell})_{\text{new case}}} \dots\dots(F.1)$$

Here, the heat transfer area implies the surface area per unit length of a tube and the cross-sectional area refers to that of a unit cell.

1) For Triangular Tube Layouts

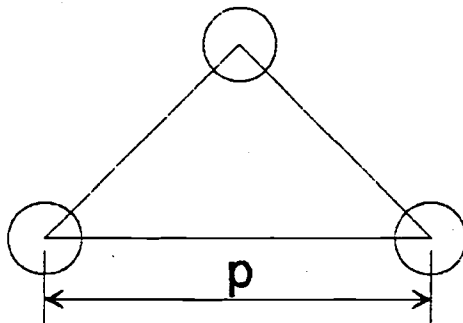

Figure F.1 Unit Cell Array for Triangular Pitch Layout (Not to Scale).

The unit cell is comprised of 3 tubes and 1/6th the surface area of each tube lies within this cell.

Hence,

$$\text{Surface area of a unit cell} = 1/6 (\text{Surface area of one tube}) \times (3 \text{ tubes per cell})$$

$$\text{i.e., } (\text{Surface area})_{\text{unit cell}} = 1/2 (\text{Surface area of one tube})$$

The cross-sectional area of the unit cell will be the area formed by the 3 tubes at pitch 'p'.

Therefore,

$$(\text{Cross-sectional area})_{\text{unit cell}} = 0.433 p^2$$

The reference case for factor F_1 is 19.05 mm. outside diameter tubes on 23.81 mm. triangular pitch.

For 19.05 mm. OD tubes, from Appendix C,

$$\text{Surface area of one tube} = 0.1963 (\text{ft}^2/\text{ft}) \times 305 = 60 (\text{mm}^2/\text{mm})$$

$$\text{and } (\text{Surface area})_{\text{unit cell}} = 30 (\text{mm}^2/\text{mm})$$

Hence, for the reference case,

$$\frac{(\text{Surface area})_{\text{unit cell}}}{(\text{Cross-sectional area})_{\text{unit cell}}} = \frac{30}{0.433(23.81)^2} = 0.122$$

Now consider 25.4 mm. OD tubes on a 31.75 mm. triangular pitch.

For 25.4 mm. OD tubes,

$$\text{Surface area of one tube} = (0.2618) \times 305 = 80 (\text{mm}^2/\text{mm})$$

and,

$$\text{cross-sectional area} = 0.433 (31.75)^2 = 436.5 \text{ mm}^2$$

Hence,

$$\frac{(\text{Surface area})_{\text{unit cell}}}{(\text{Cross-sectional area})_{\text{unit cell}}} = \frac{40}{0.433(31.75)^2}$$

$$= 0.0916$$

$$\text{and } F_1 = 0.122/0.0916 = 1.333$$

2) For Square and Rotated Square Layouts

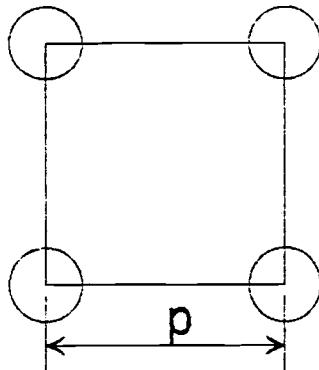

Figure F.2 Unit Cell Array for Square Pitch Layout (Not to Scale).

The unit cell comprises 4 tubes and 1/4th of the surface area of each tube lies within this cell.

Hence,

$$\text{Surface area of unit cell} = 1/4 (\text{Surface area of one tube}) (4 \text{ tubes})$$

i.e., $(\text{Surface area})_{\text{unit cell}} = \text{Surface area of one tube.}$

The cross-sectional area is the area of a square with each side being the pitch.

Therefore,

$$(\text{Cross-sectional area})_{\text{unit cell}} = p^2$$

Again, for 25.4 mm. OD tubes on 31.75 mm. square pitch,

$$\frac{(\text{Surface area})_{\text{unit cell}}}{(\text{Cross-sectional area})_{\text{unit cell}}} = \frac{0.2618(305)}{(31.75)^2}$$

$$= 0.079$$

$$\text{and } F_1 = 0.122/0.079 = 1.539$$

APPENDIX G

CORRECTION FACTOR F_2 FOR NUMBER OF TUBE-SIDE PASSES

The correction factor F_2 for number of tube-side passes is defined as:

$$F_2 = \frac{\text{Number of tubes in heat exchanger with one tube-side pass}}{\text{Number of tubes in heat exchanger with 'n' tube-side passes}} \dots\dots\dots(G.1)$$

where $n = 2, 4, 6, \dots\dots$

and the heat exchangers have the same tube layout and inside shell diameter

In the following tables, D_i refers to the shell inside diameter.

Table G.1 : Correction Factor F_2 for Fixed Tubesheet Heat Exchangers.

D_i m.	FACTOR F_2		
	2 PASS	4 PASS	6 PASS
0.203-0.337	1.113	1.400	1.613
0.387-0.540	1.059	1.173	1.244
0.591-0.737	1.038	1.109	1.151
0.787-0.940	1.029	1.080	1.109
0.991-1.219	1.022	1.061	1.083
1.295-1.524	1.017	1.047	1.063

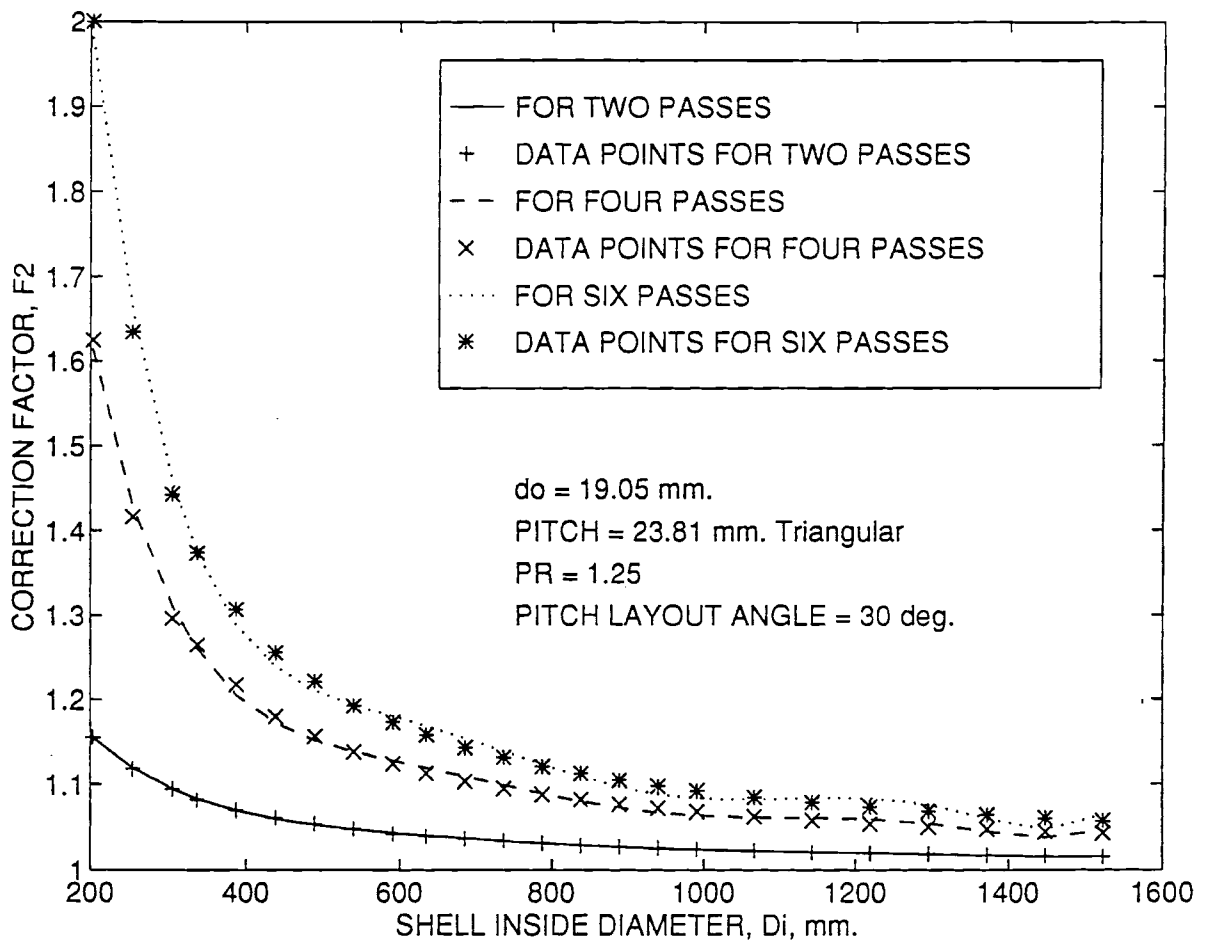

Figure G.1 : Correction Factor F_2 for Fixed Tubesheet Heat Exchanger.

Table G.2 : Correction Factor F_2 for SRFH Heat Exchangers.
(SRFH = Split-ring Floating Head)

D_i m.	FACTOR F_2		
	2 PASS	4 PASS	6 PASS
0.203-0.337	1.142	1.561	1.944
0.387-0.540	1.066	1.197	1.280
0.591-0.737	1.042	1.120	1.167
0.787-0.940	1.031	1.086	1.118
0.991-1.219	1.023	1.065	1.088
1.295-1.524	1.018	1.049	1.066

Table G.3 : Correction Factor F_2 for U-Tube Heat Exchangers.

D_i m.	FACTOR F_2	
	4 PASS	6 PASS
0.203-0.337	1.165	1.323
0.387-0.540	1.068	1.146
0.591-0.737	1.041	1.090
0.787-0.940	1.031	1.071
0.991-1.219	1.025	1.054
1.295-1.524	1.018	1.035

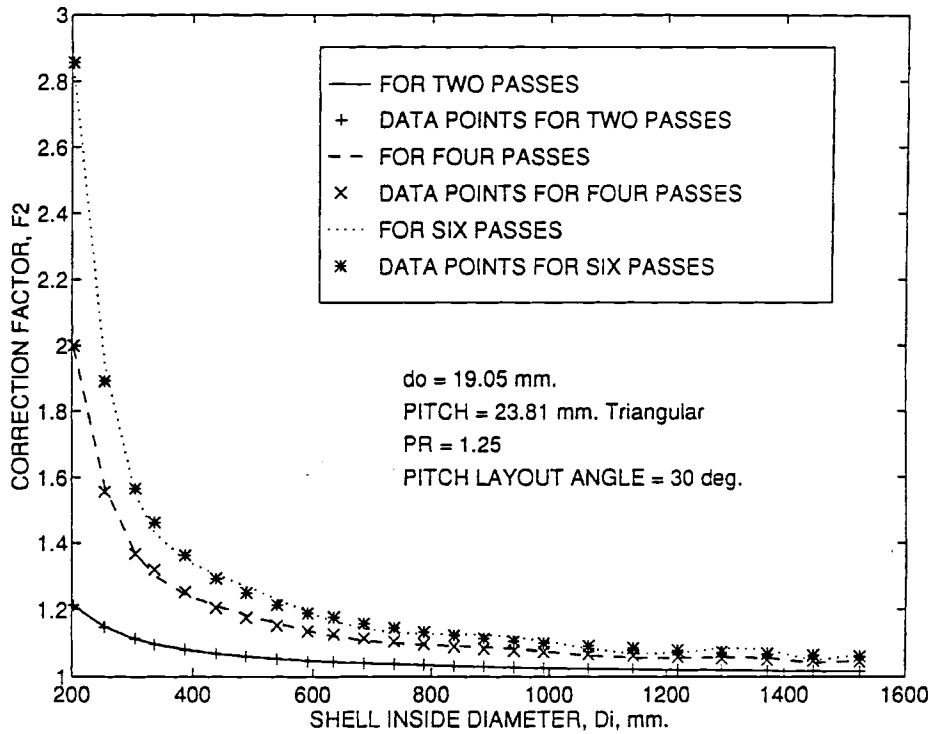

Figure G.2 : Correction Factor F_2 for Split Ring Floating Head Heat Exchangers.

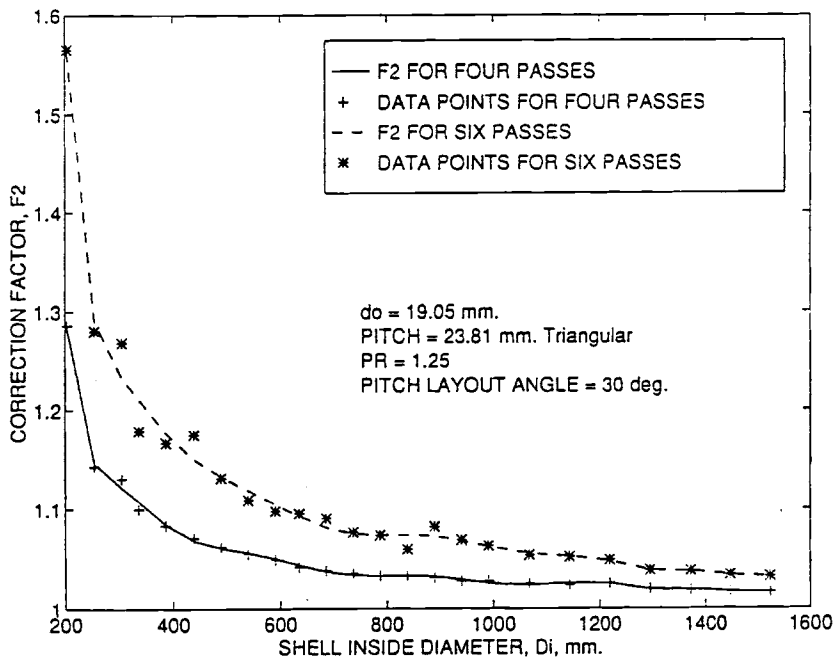

Figure G.3 : Correction Factor F_2 for U-Tube Heat Exchangers.

Table G.4 : Correction Factor F_2 for PTFH Heat Exchangers.
Pressure = 1000 KPa

D_i m.	FACTOR F_2 .		
	2 PASS	4 PASS	6 PASS
0.203-0.337	1.162	1.692	2.352
0.387-0.540	1.077	1.241	1.342
0.591-0.737	1.046	1.132	1.184
0.787-0.940	1.033	1.093	1.128
0.991-1.219	1.025	1.070	1.095
1.295-1.524	1.019	1.052	1.070

Table G.5 : Correction factor F_2 for PTFH Heat Exchangers.
Pressure = 2000 KPa

D_i m.	FACTOR F_2		
	2 PASS	4 PASS	6 PASS
0.203-0.337	1.176	1.754	2.324
0.387-0.540	1.077	1.239	1.343
0.591-0.737	1.047	1.132	1.184
0.787-0.940	1.033	1.093	1.128
0.991-1.219	1.025	1.070	1.095
1.295-1.524	1.019	1.052	1.070

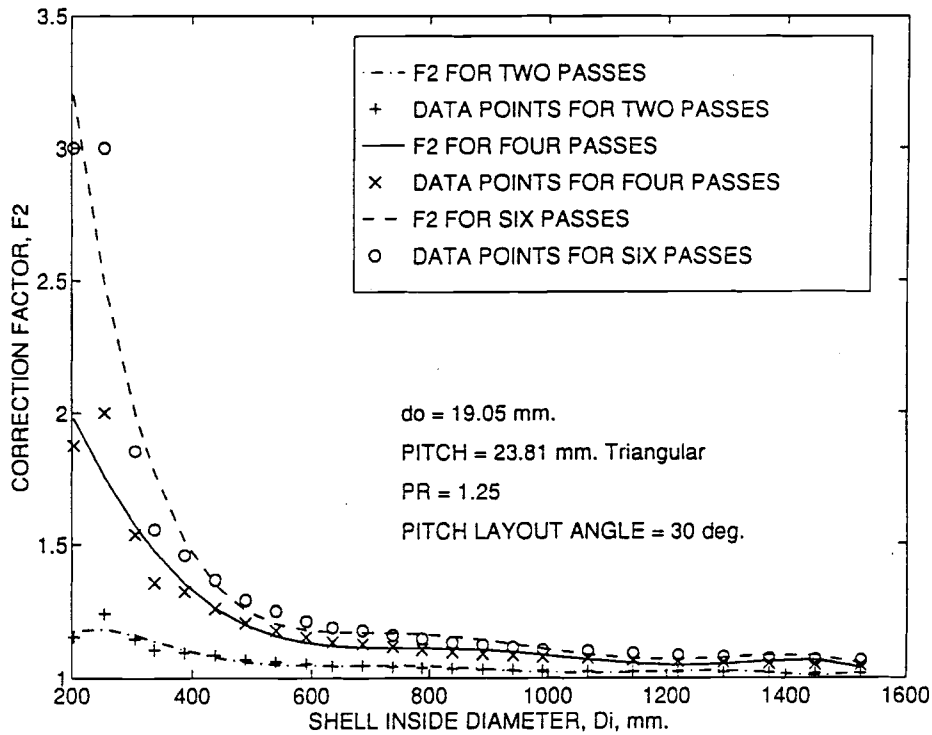

Figure G.4 : Correction Factor F_2 for Pull-through Floating Head Heat Exchangers.
 Pressure = 1000 KPa.

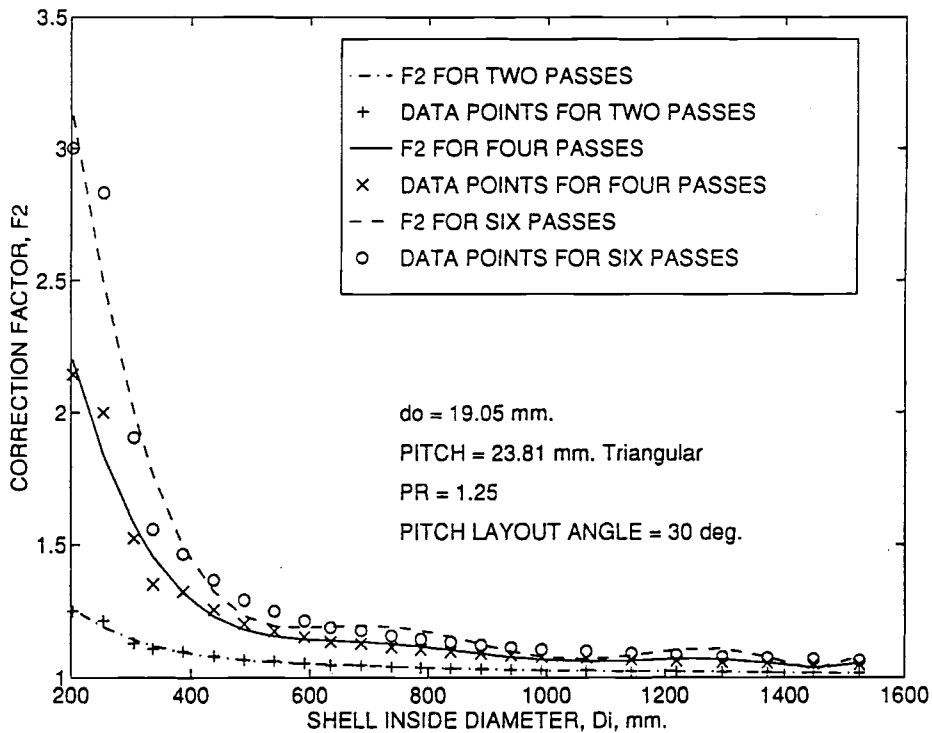

Figure G.5 : Correction Factor F_2 for Pull-through Floating Head Heat Exchangers.
 Pressure = 2000 KPa.

APPENDIX H

CORRECTION FACTOR F_3 FOR VARIOUS SHELL CONSTRUCTIONS/TUBE BUNDLE LAYOUTS

The correction factor F_3 for shell construction/tube bundle layout type is defined as:

$$F_3 = \frac{\text{Number of tubes in 'n' tube - side passes of fixed tubesheet heat exchanger}}{\text{Number of tubes in 'n' tube - side passes of other type of heat exchanger}} \dots\dots(H.1)$$

where $n = 1, 2, 4, \dots\dots$

and the heat exchangers have the same tube layout, shell inside diameter and number of passes

Correction factor $F_3 = 1$ for fixed tubesheet exchangers.

In the following tables, D_i refers to the shell inside diameter.

Table H.1 : Correction Factor F_3 for Split Ring Floating Head Heat Exchangers.

D_i m	FACTOR F_3			
	1 PASS	2 PASS	4 PASS	6 PASS
0.203-0.337	1.213	1.246	1.347	1.444
0.387-0.540	1.112	1.119	1.134	1.144
0.591-0.737	1.090	1.094	1.101	1.105
0.787-0.940	1.072	1.074	1.078	1.080
0.991-1.219	1.059	1.060	1.063	1.064
1.295-1.524	1.045	1.046	1.047	1.048

Table H.2 : Correction Factor F_3 for U-Tube Heat Exchangers.

D_i m	FACTOR F_3		
	2 PASS	4 PASS	6 PASS
0.203-0.337	1.250	1.143	1.000
0.387-0.540	1.082	1.039	1.043
0.591-0.737	1.047	1.021	1.029
0.787-0.940	1.034	1.015	1.027
0.991-1.219	1.024	1.012	1.019
1.295-1.524	1.020	1.008	1.010

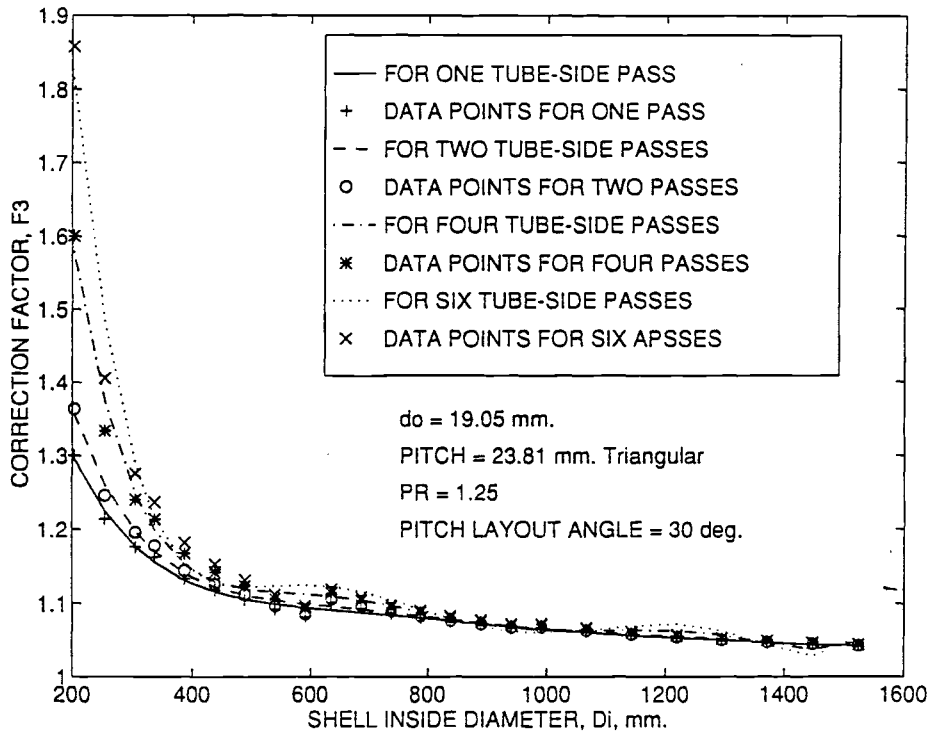

Figure H.1 : Correction Factor F_3 for Split Ring Floating Head Heat Exchangers.

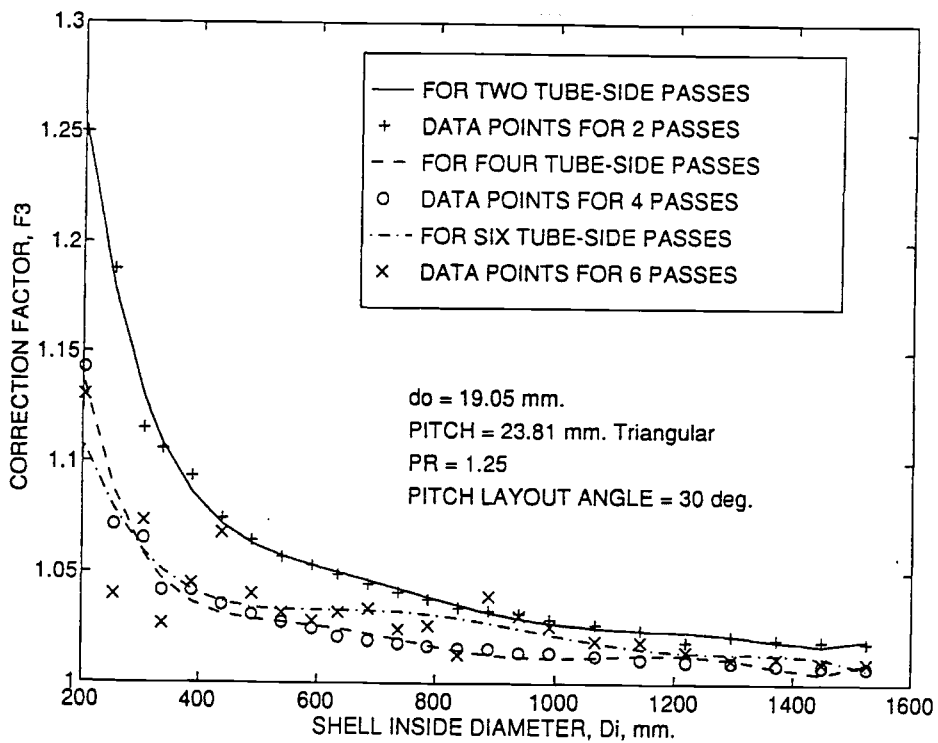

Figure H.2 : Correction Factor F_3 for U-Tube Heat Exchangers.

Table H.3 : Correction Factor F_3 for Pull-through Floating Head Heat Exchangers.
(Pressure = 1000 KPa)

D_i m	FACTOR F_3			
	1 PASS	2 PASS	4 PASS	6 PASS
0.203-0.337	2.431	2.528	2.935	3.563
0.387-0.540	1.532	1.558	1.622	1.654
0.591-0.737	1.342	1.352	1.370	1.380
0.787-0.940	1.258	1.263	1.273	1.279
0.991-1.219	1.200	1.203	1.210	1.213
1.295-1.524	1.165	1.167	1.171	1.173

Table H.4 : Correction Factor F_3 for Pull-through Floating Head Heat Exchangers.
(Pressure = 2000 KPa)

D_i m	FACTOR F_3			
	1 PASS	2 PASS	4 PASS	6 PASS
0.203-0.337	2.500	2.653	3.159	3.624
0.387-0.540	1.589	1.617	1.680	1.717
0.591-0.737	1.395	1.406	1.424	1.435
0.787-0.940	1.311	1.317	1.327	1.334
0.991-1.219	1.244	1.247	1.254	1.258
1.295-1.524	1.201	1.204	1.208	1.210

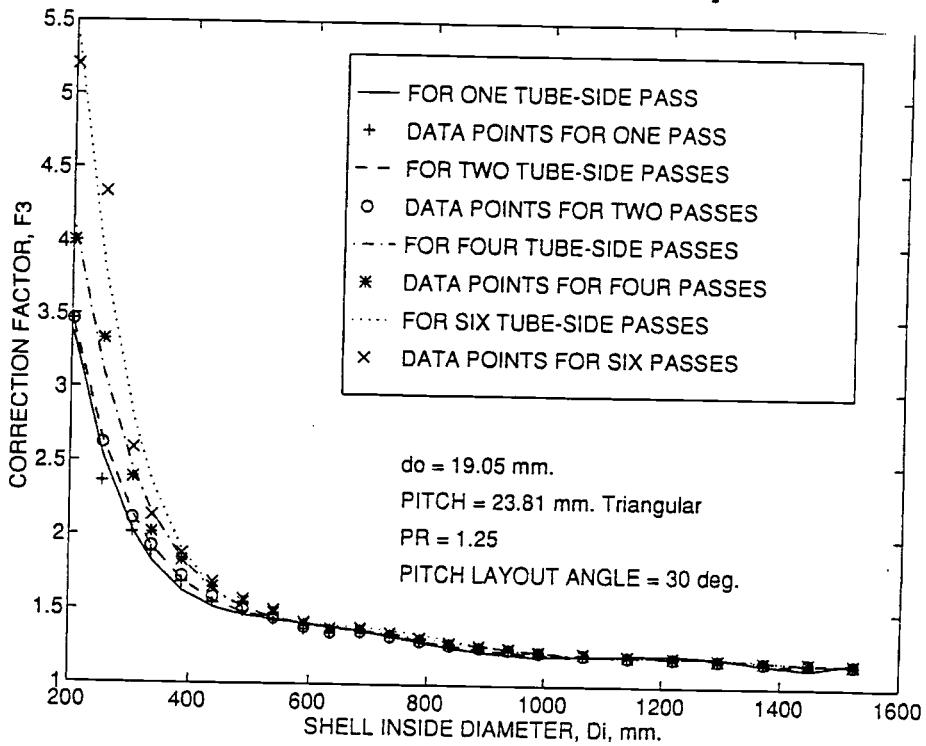

Figure H.3 : Correction Factor F_3 for Pull-through Floating Head Heat Exchangers.
Pressure = 1000 KPa.

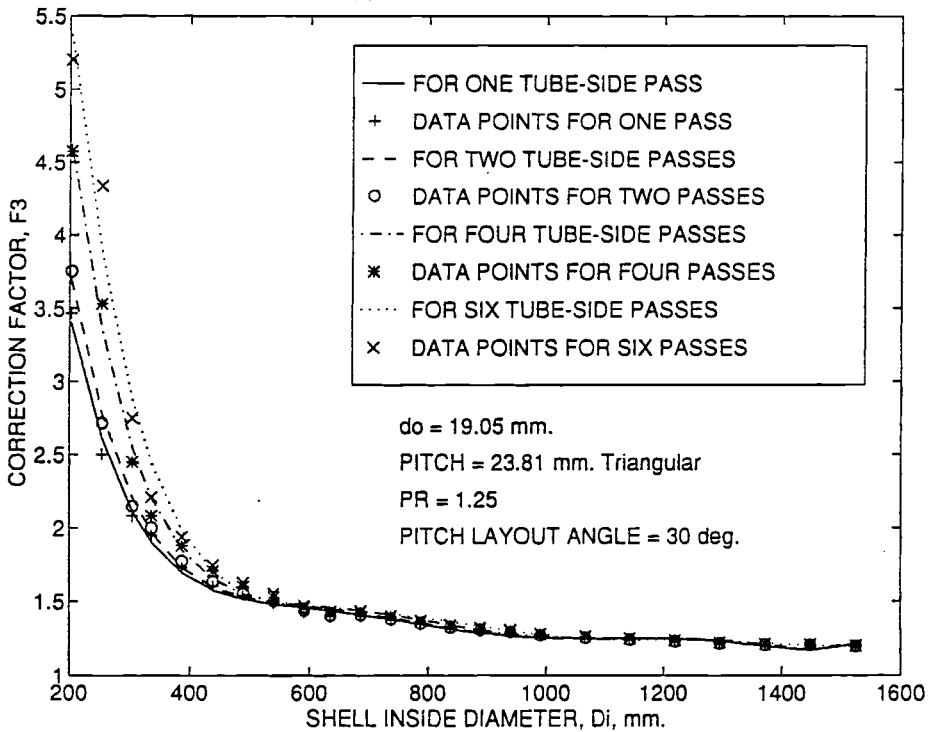

Figure H.4 : Correction Factor F_3 for Pull-through Floating Head Heat Exchangers.
Pressure = 2000 KPa.

APPENDIX I

PACKING FACTOR FOR VARIOUS EXCHANGER CONFIGURATIONS

The packing factor has been calculated for 19.05 mm. outside diameter tubes on 23.81 mm. triangular pitch layout, two tube-side passes and a pitch ratio (PR) of 1.25.

In the following tables,

F_p refers to the packing factor,

D_{otl} refers to the diameter of outer tube limit,

L_{tp} refers to the tube pitch layout and

L_{bb} refers to the clearance between the shell inside diameter and the diameter of outer tube limit.

Table I.1 : Packing Factor for Fixed Tubesheet Heat Exchangers.

D_i mm.	N_t	L_{bb} mm.	D_{otl} mm.	D_{otl}/L_{tp}	F_p
203	45	13	190	7.980	0.7796
254	76	13	241	10.122	0.8184
305	116	13	292	12.264	0.8509
337	146	15	322	13.524	0.8807
387	199	16	371	15.582	0.9042
438	260	16	422	17.724	0.9131
489	330	16	473	19.866	0.9225
540	408	16	524	22.008	0.9293
591	495	17	574	24.108	0.9396
635	577	17	618	25.956	0.9449
686	679	17	669	28.097	0.9488
737	789	17	720	30.239	0.9519
787	907	18	769	32.297	0.9592
838	1034	18	820	34.439	0.9617
889	1169	18	871	36.581	0.9637
940	1312	18	922	38.723	0.9652
991	1463	19	972	40.823	0.9685
1067	1706	19	1048	44.015	0.9715
1143	1968	19	1124	47.207	0.9742
1219	2247	19	1200	50.399	0.9759
1295	2545	20	1275	53.549	0.9791
1372	2862	20	1352	56.783	0.9792
1448	3198	20	1428	59.975	0.9808
1524	3552	21	1503	63.125	0.9834

Table I.2 : Packing Factor for U-Tube Heat Exchangers.

D_i mm.	N_t	L_{bb} mm.	D_{otl} mm.	D_{otl}/L_{tp}	F_p
203	36	13	190	7.980	0.624
254	64	13	241	10.122	0.689
305	104	13	292	12.264	0.763
337	132	15	322	13.524	0.796
387	182	16	371	15.582	0.827
438	242	16	422	17.724	0.850
489	310	16	473	19.866	0.867
540	386	16	524	22.008	0.879
591	470	17	574	24.108	0.892
635	550	17	618	25.956	0.901
686	650	17	669	28.097	0.908
737	758	17	720	30.239	0.915
787	874	18	769	32.297	0.924
838	1000	18	820	34.439	0.930
889	1132	18	871	36.581	0.933
940	1272	18	922	38.723	0.936
991	1422	19	972	40.823	0.941
1067	1662	19	1048	44.015	0.946
1143	1922	19	1124	47.207	0.952
1219	2206	19	1200	50.399	0.958
1295	2492	20	1275	53.549	0.959
1372	2806	20	1352	56.783	0.960
1448	3138	20	1428	59.975	0.962
1524	3488	21	1503	63.125	0.966

Table I.3 : Packing Factor for Split Ring Floating Head Heat Exchangers.

D_i mm.	N_t	L_{bb} mm.	D_{otl} mm.	D_{otl}/L_{tp}	F_p
203	33	28.0	175	7.350	0.674
254	61	28.0	226	9.492	0.747
305	97	28.0	277	11.634	0.791
337	124	31.5	306	12.831	0.831
387	174	32.5	354	14.889	0.866
438	231	32.5	406	17.031	0.879
489	297	32.5	456	19.173	0.891
540	372	34.5	506	21.231	0.911
591	456	35.0	556	23.352	0.923
635	522	35.0	600	25.200	0.907
686	619	35.0	651	27.342	0.914
737	725	37.5	700	29.378	0.927
787	838	39.0	748	31.415	0.937
838	961	39.0	799	33.557	0.941
889	1091	39.0	850	35.699	0.944
940	1230	41.0	899	37.757	0.952
991	1371	43.0	948	39.815	0.954
1067	1606	43.0	1024	43.007	0.958
1143	1861	43.0	1100	46.199	0.962
1219	2133	46.0	1173	49.265	0.970
1295	2424	47.0	1248	52.415	0.973
1372	2733	47.0	1325	55.649	0.974
1448	3062	48.0	1400	58.799	0.977
1524	3408	52.0	1472	61.823	0.984

Table I.4: Packing Factor for Pull-through Floating Head Heat Exchangers.
 Pressure = 1000 KPa.

D_i mm.	N_t	L_{bb} mm.	D_{otl} mm.	D_{otl}/L_{tp}	F_p
203	13	87	116	4.872	0.604
254	29	88	166	6.972	0.658
305	55	89	216	9.072	0.737
337	76	90	247	10.374	0.779
387	116	91	296	12.432	0.828
438	165	92	346	14.532	0.862
489	220	93	396	16.632	0.877
540	283	94	446	18.732	0.890
591	358	95	496	20.832	0.910
635	428	96	539	22.638	0.921
686	502	97	589	24.738	0.905
737	596	98	639	26.838	0.913
787	701	99	688	28.895	0.926
838	815	100	738	30.995	0.936
889	934	101	788	33.095	0.941
940	1060	102	838	35.195	0.944
991	1199	103	888	37.295	0.951
1067	1413	105	962	40.403	0.955
1143	1645	107	1036	43.511	0.959
1219	1889	111	1108	46.535	0.962
1295	2159	115	1180	49.559	0.970
1372	2452	117	1255	52.709	0.974
1448	2746	120	1328	55.775	0.974
1524	3071	122	1402	58.883	0.977

Table I.5 : Packing Factor for Pull-through Floating Head Heat Exchangers.
 Pressure = 2000 KPa.

D_i mm.	N_t	L_{bb} mm.	D_{otl} mm.	D_{otl}/L_{tp}	F_p
203	12	90	113	4.746	0.588
254	28	91	163	6.846	0.659
305	54	92	213	8.946	0.744
337	73	94	243	10.206	0.773
387	112	96	291	12.222	0.827
438	159	98	340	14.280	0.860
489	212	100	389	16.338	0.876
540	272	102	438	18.396	0.887
591	344	104	487	20.454	0.907
635	411	106	529	22.218	0.919
686	483	108	578	24.276	0.904
737	573	110	627	26.334	0.912
787	672	113	674	28.307	0.925
838	782	115	723	30.365	0.936
889	896	117	772	32.423	0.940
940	1016	119	821	34.481	0.943
991	1153	120	871	36.581	0.951
1067	1362	122	945	39.689	0.954
1143	1587	125	1018	42.755	0.958
1219	1830	128	1091	45.821	0.962
1295	2096	132	1163	48.845	0.969
1372	2377	136	1236	51.911	0.973
1448	2662	140	1308	54.935	0.973
1524	2974	144	1380	57.959	0.977

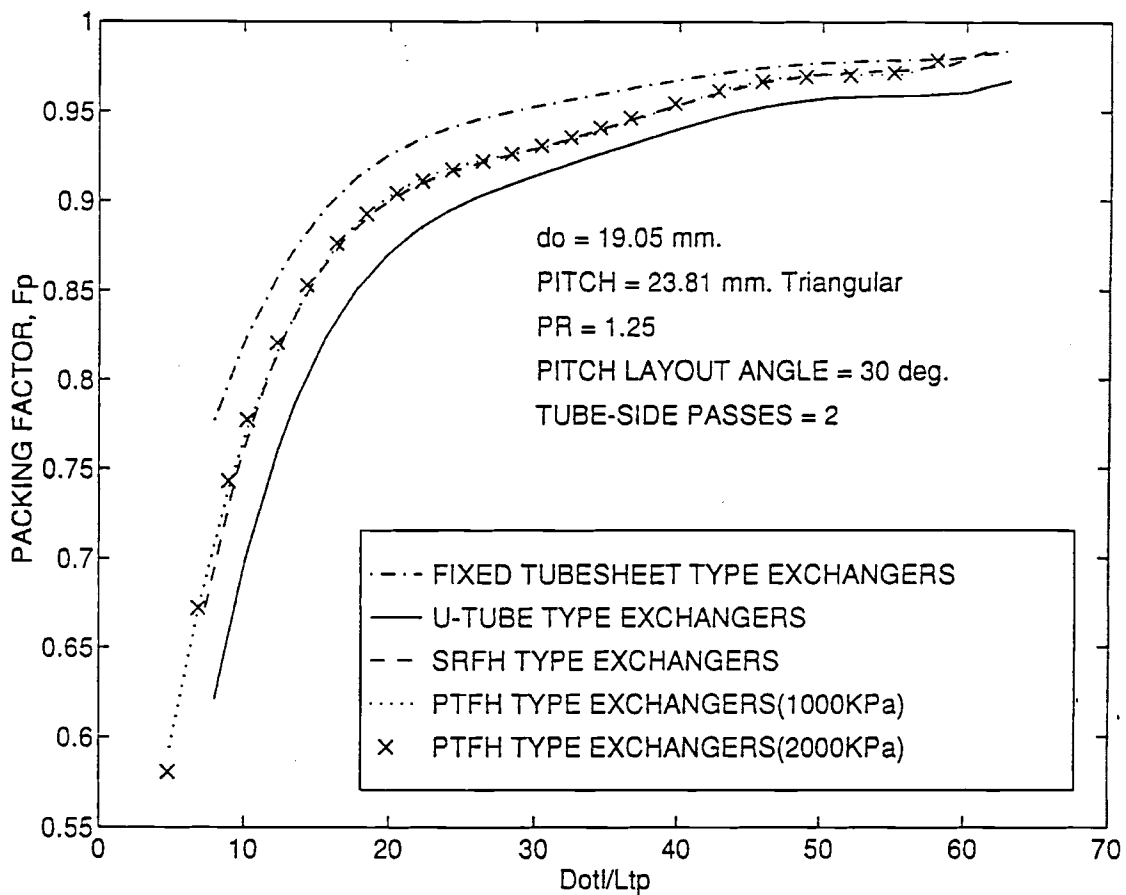

Figure I.1 : Packing Factor as a Function of the Diameter of Outer Tube Limit and Tube Pitch Layout for Various Exchanger Configurations.

APPENDIX J

BAFFLE SPACING ESTIMATION

Baffle spacing in a shell and tube heat exchanger can be estimated by assuming that the velocity of the shell-side fluid in the crossflow section is approximately equal to that in the window section. The main advantage of this is that the equal velocities in the window and crossflow regions tends to maximize the effective use of pressure drop to create higher heat transfer coefficients. By making the above mentioned assumption, we get a relationship for the baffle spacing as a function of the baffle cut and the shell inside diameter. The baffle spacing derived in this manner is not a strong function of the tube size and tube pitch layout.

The plots presented below can be used to estimate the baffle spacing if the percent baffle cut and the shell inside diameter are known.

The plots provided here are for 19.05 mm. outside diameter plain tubes on a 23.81 mm. triangular pitch layout and two tube-side passes, 19.05 mm outside diameter plain tubes on a 25.4 mm triangular pitch and two tube-side passes, and 19.05 mm outside diameter plain tubes on a 25.4 mm square pitch and two tube-side passes.

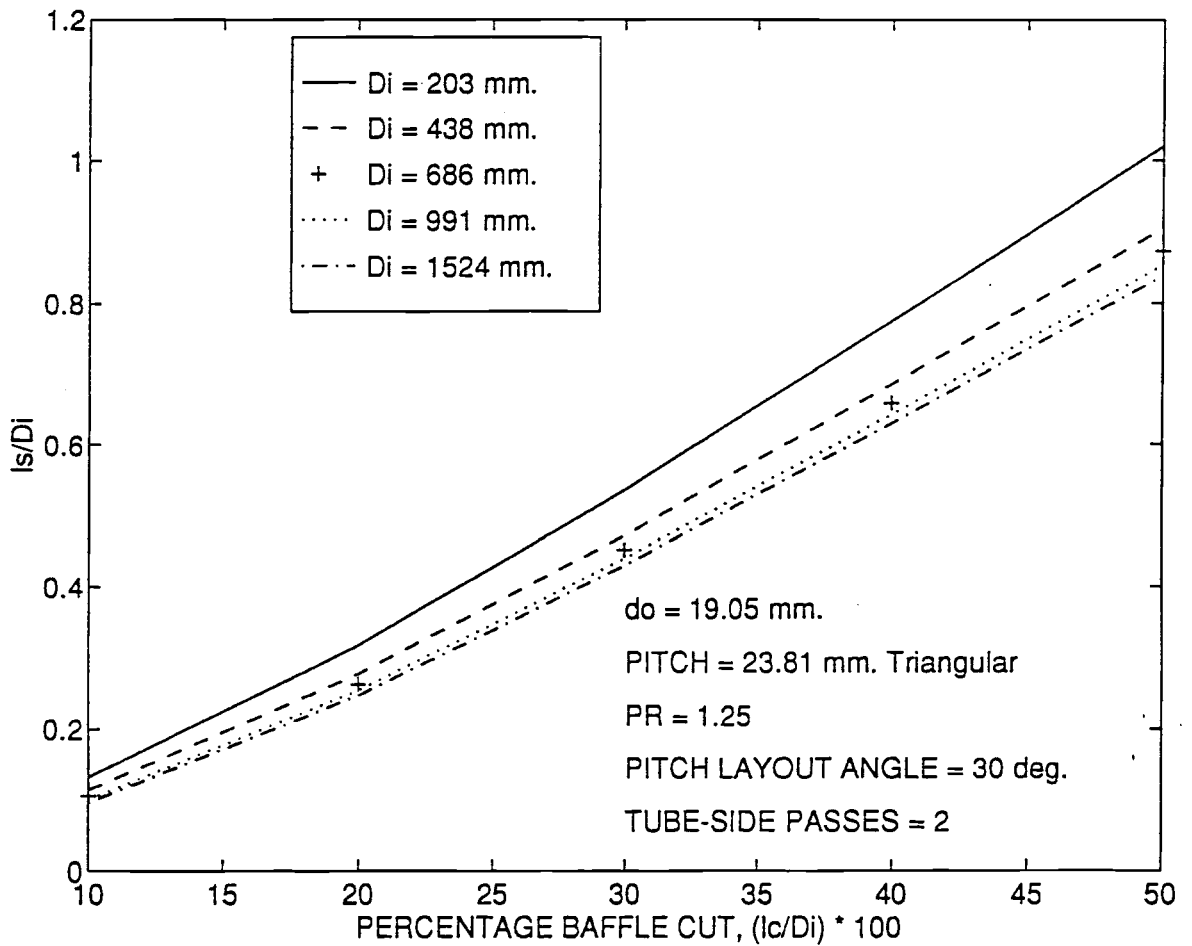

Figure J.1 : Baffle Spacing as a Function of Baffle Cut and Shell Inside Diameter for Fixed Tubesheet Heat Exchangers.

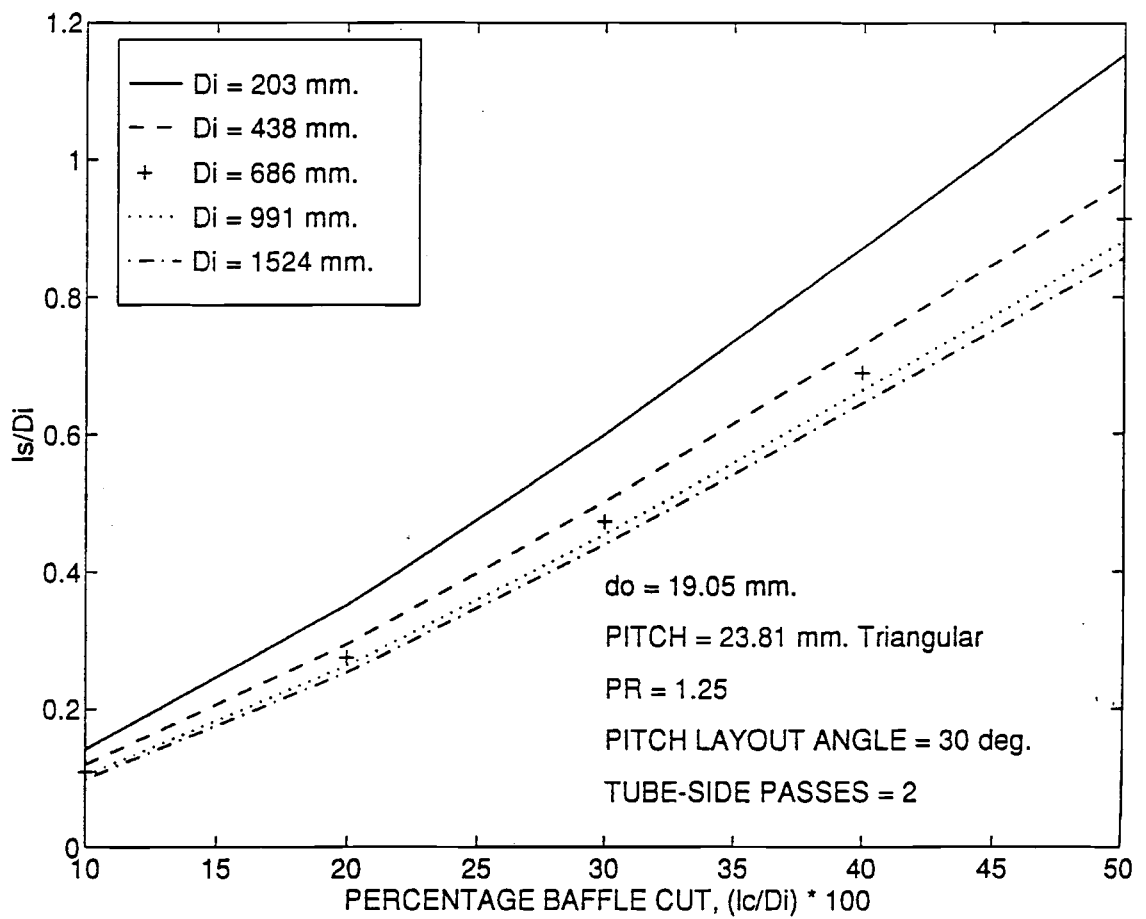

Figure J.2 : Baffle Spacing as a Function of Baffle Cut and Shell Inside Diameter for U-Tube Heat Exchangers.

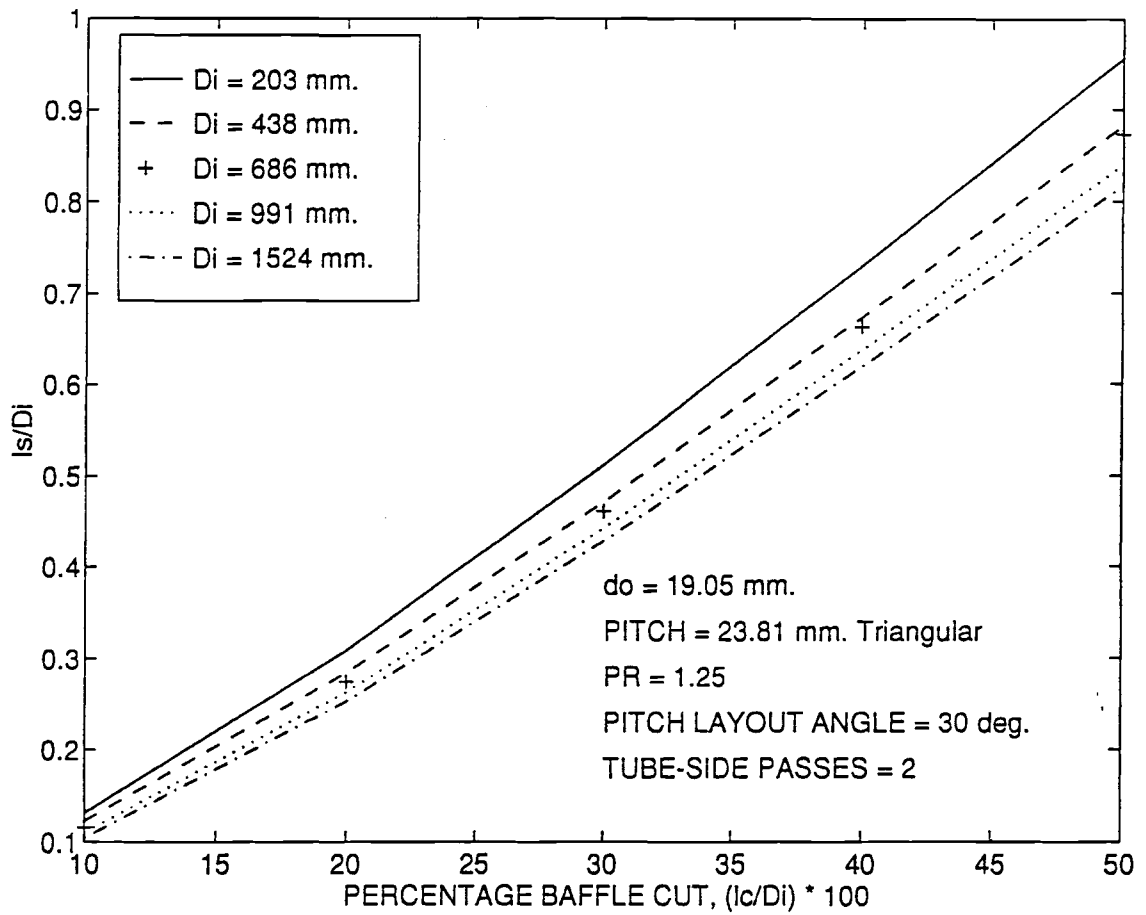

Figure J.3 : Baffle Spacing as a Function of Baffle Cut and Shell Inside Diameter for Split Ring Floating Head Heat Exchangers.

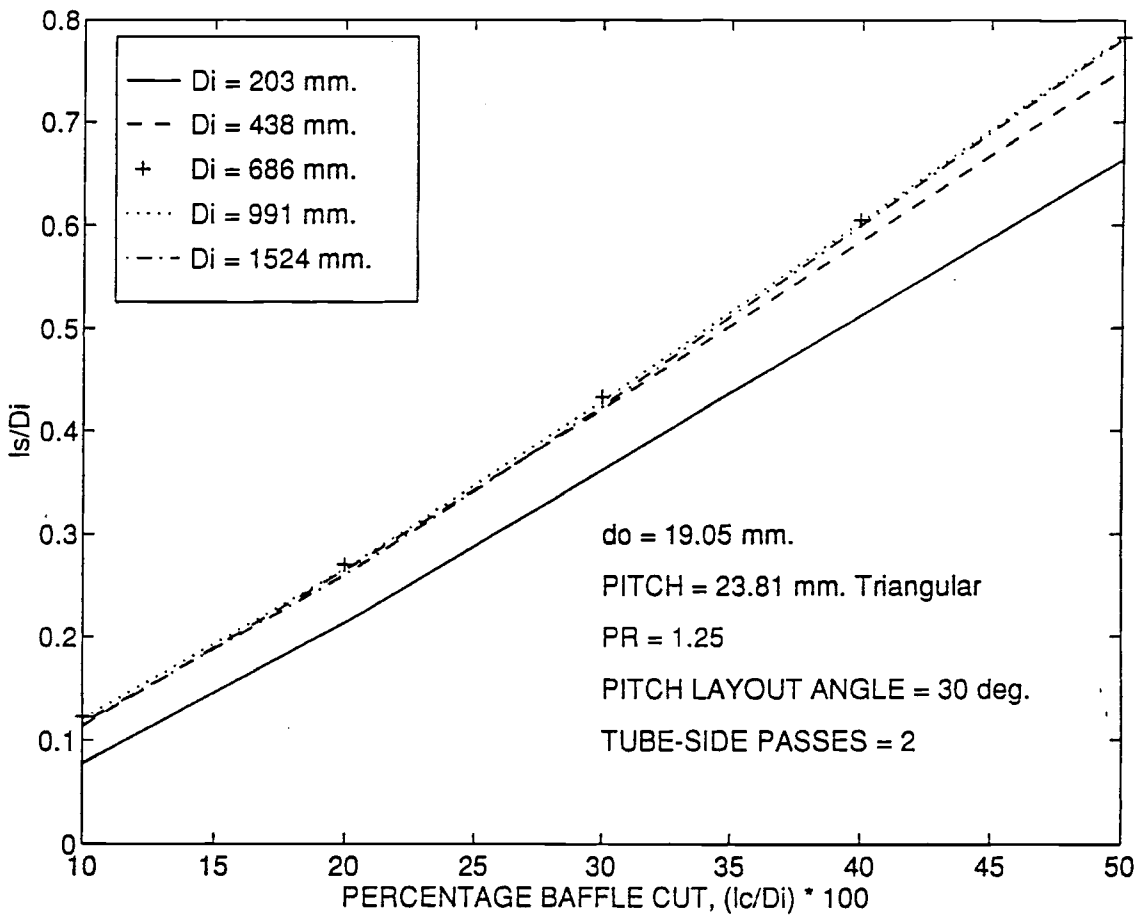

Figure J.4 : Baffle Spacing as a Function of Baffle Cut and Shell Inside Diameter for Pull-through Floating Head Heat Exchangers (Pressure = 1000 KPa).

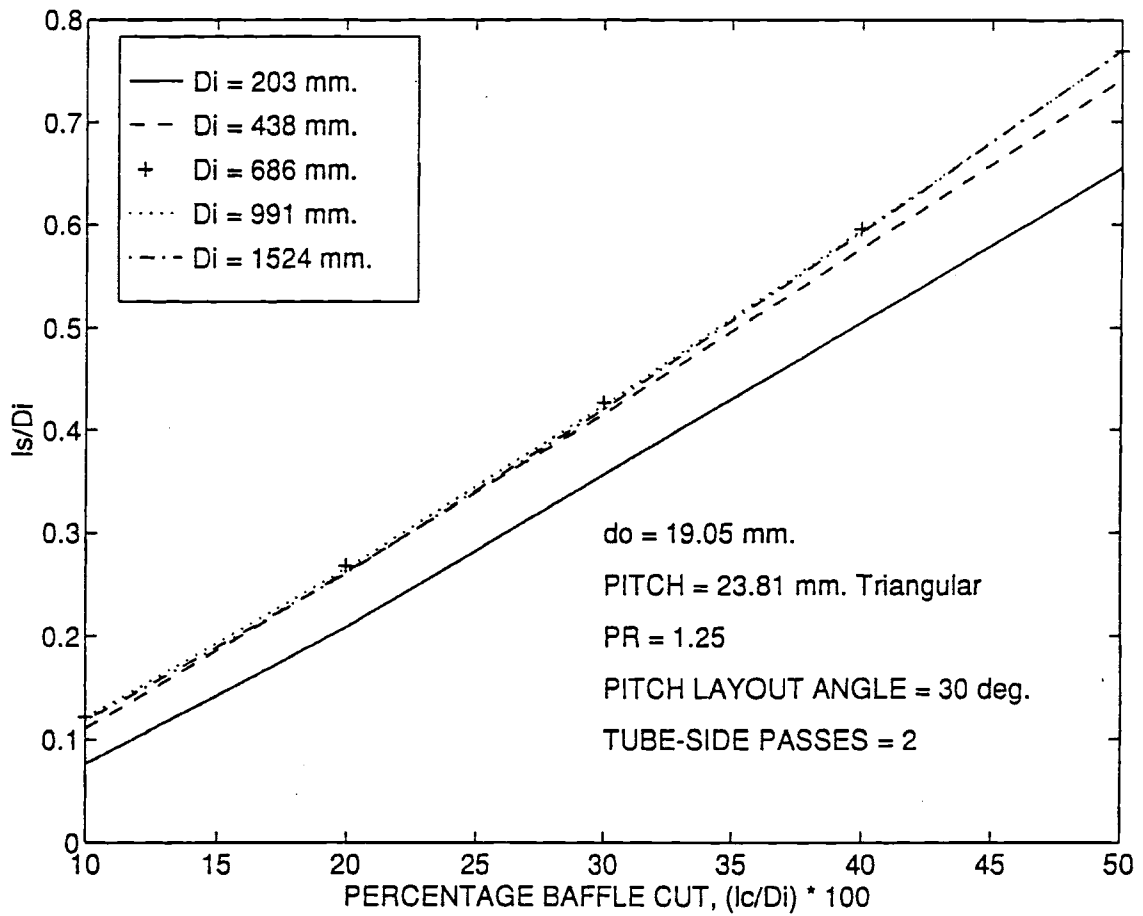

Figure J.5 : Baffle Spacing as a Function of Baffle Cut and Shell Inside Diameter for Pull-through Floating Head Heat Exchangers (Pressure = 2000 KPa).

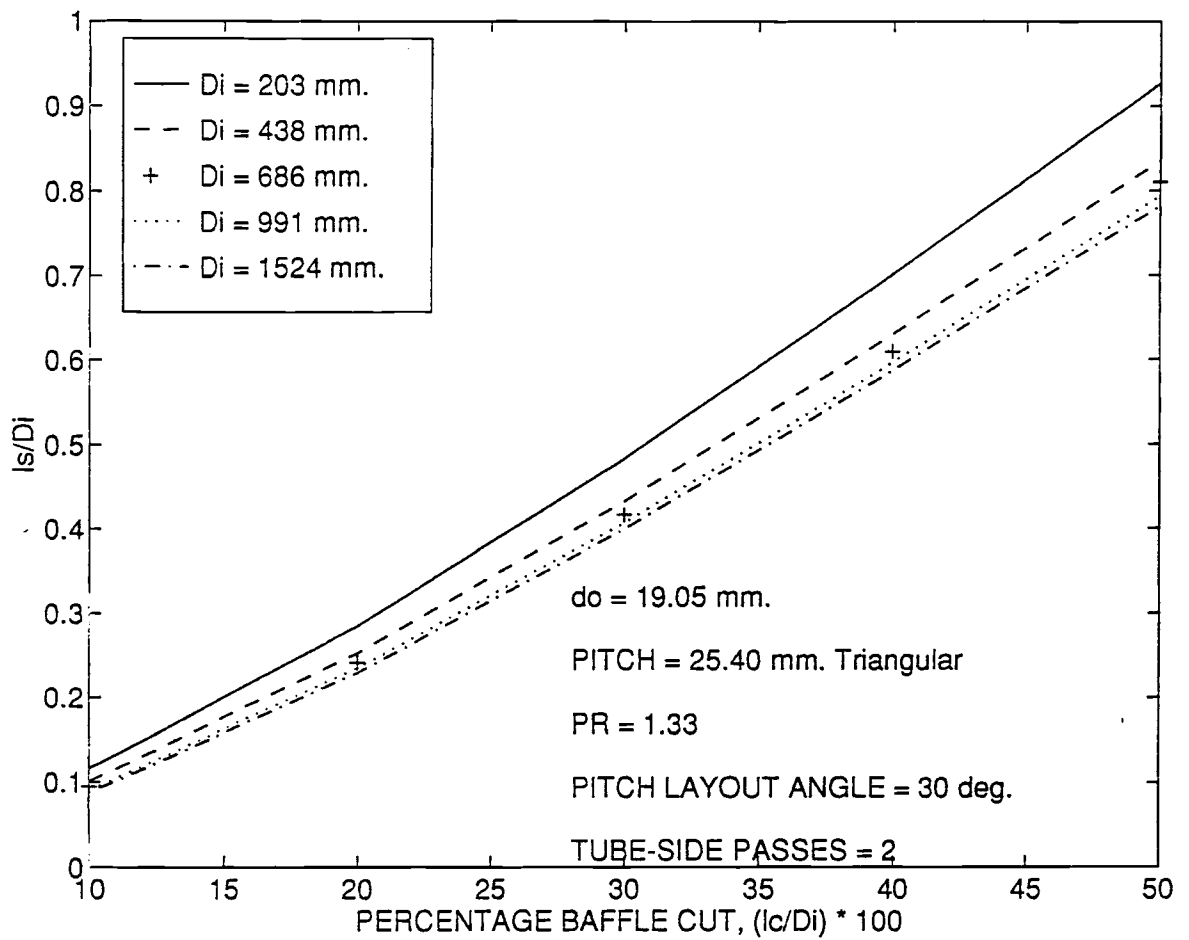

Figure J.6 : Baffle Spacing as a Function of Baffle Cut and Shell Inside Diameter for Fixed Tubesheet Heat Exchangers.

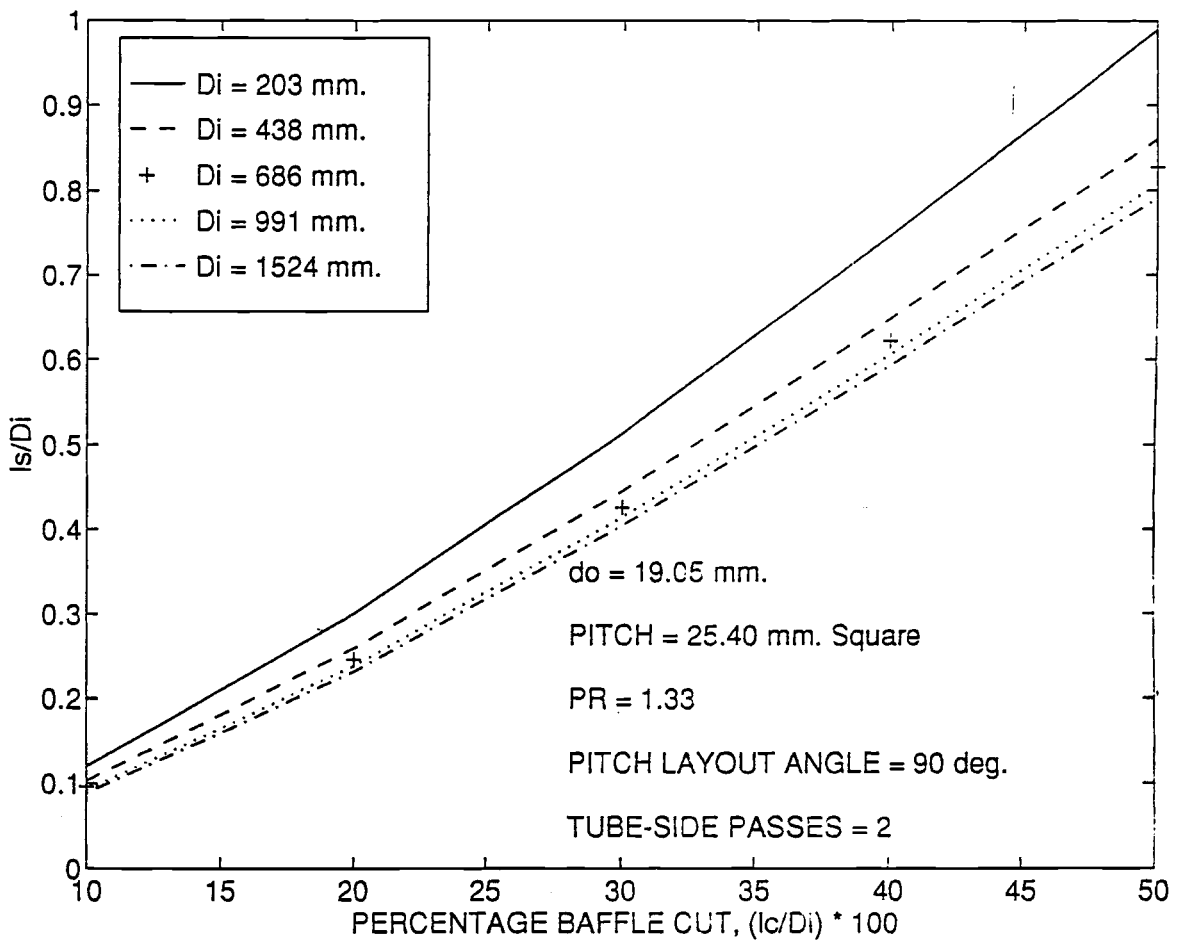

Figure J.7 : Baffle Spacing as a Function of Baffle Cut and Shell Inside Diameter for Fixed Tubesheet Heat Exchangers.

VITA

Jayesh Modi

Candidate for the Degree of

Master of Science

Thesis: QUICK MANUAL DESIGN OF SHELL AND TUBE
HEAT EXCHANGERS

Major Field: Chemical Engineering

Biographical:

Personal Data: Born in Bombay, India, on October 19, 1969, the son of Behari and Pravina Modi.

Education: Graduated from St. Theresa's High School, Bombay, India, in May 1985; received Bachelor of Engineering degree in Chemical Engineering from the University of Poona, Pune, India in June 1991. Completed the requirements for the Master of Science degree with a major in Chemical Engineering at Oklahoma State University in May 1995.

Experience: Employed by Unik Engineering Services, "Equipment Design Engineers," Bombay, India, as a Design Engineer, July 1991 to December 1992; Graduate research and teaching assistant at Oklahoma State University, spring 1993 to summer 1994.

Professional Membership: American Institute of Chemical Engineers.