

UNIVERSITY OF OKLAHOMA

GRADUATE COLLEGE

SUPPLY CHAIN PROCESS INTEGRATION:  
A CONCEPTUAL AND EMPIRICAL EXAMINATION

A DISSERTATION

SUBMITTED TO THE GRADUATE FACULTY

in partial fulfillment of the requirements for the

Degree of

DOCTOR OF PHILOSOPHY

By

HAOZHE CHEN  
Norman, Oklahoma  
2007

UMI Number: 3291927



---

UMI Microform 3291927

Copyright 2008 by ProQuest Information and Learning Company.  
All rights reserved. This microform edition is protected against  
unauthorized copying under Title 17, United States Code.

---

ProQuest Information and Learning Company  
300 North Zeeb Road  
P.O. Box 1346  
Ann Arbor, MI 48106-1346

SUPPLY CHAIN PROCESS INTEGRATION:  
A CONCEPTUAL AND EMPIRICAL EXAMINATION

A DISSERTATION APPROVED FOR THE  
MICHAEL F. PRICE COLLEGE OF BUSINESS

BY

---

Patricia J. Daugherty, Chair

---

Michael R. Buckley

---

Timothy D. Landry

---

Soonhong Min

---

Anthony S. Roath

© Copyright by HAOZHE CHEN 2007  
All Rights Reserved.

## ACKNOWLEDGEMENTS

I would not have completed my doctoral study and this dissertation without the help and support from many people. I want to express my sincere appreciation to all who have provided me with intellectual guidance and emotional support.

First, this dissertation is dedicated to my committee chair and major professor, Pat Daugherty. Pat's unwavering support and guidance have been instrumental to my growth as a researcher and as a person. I am deeply indebted to Pat in so many ways that no words can adequately express my thankfulness.

My deepest appreciation also goes to Alex Ellinger, who guided me into the wonderful academic world of supply chain management. Over the years, Alex has been a great mentor, friend, and "uncle" to me. His enduring belief in me provides me the confidence to pursue my goals.

I wish to give my heartfelt thanks to my dissertation committee members. Mike Buckley always offered inspiring encouragement when I needed it the most. I also benefited enormously from other committee members in developing my research skills. Soonhong (Hong) Min taught me to have an appropriate "orientation" toward research; Tony Roath helped me understand that an attitude of "governance" is critical to any study; and Tim Landry showed me how to take a good "control" of various research thoughts. They helped me muddle through the muck of disorganized and chaotic ideas through the sharing of their expertise and constructive criticism on a daily basis.

I feel very fortunate to have several outstanding "brothers" in the Ph.D. program – Elten Briggs, Stefan Genchev, Dan Mattioda, Aaron Arndt, and Scott Grawe. I will cherish the sensational time spent with them and I cannot imagine finishing my study

without their company. I also want to thank other people in the department – Jack Kasulis, John Hobbs, Samir Barman, Ford Smith, Jeff Schmidt, Jeff Wallman, Ken Gross, and Johnnie Ferguson – for making my life at OU enjoyable and memorable. I also must thank Glenn Richey for helping me continuously and setting up a great role model.

I owe a tremendous debt of gratitude to my friends and participating managers of this study in China. The data collection for this dissertation would not have been successful without their understanding and cooperation. I am especially thankful to Yuan Xu, Ning Zhang, Haifa Sun, Meiping Liu, Rui Huang, Xiujian Chen, and Whitley Huang for their help.

I am blessed to have the constant support from my family in China. My parents, Xinzhong Chen and Runjun Xu, are always my biggest supporters for whatever I pursue. My brother, Haoyu Chen, never said no to me and played a vital role in helping my data collection.

Finally and most importantly, I want to dedicate this dissertation to my beloved wife, Jing, and my lovely daughter, Connie. Jing displayed tremendous faith, perseverance, and trust in me over the years by sacrificing her career, time, and energy to support my study. Since her birth, Connie has been providing me with endless inspiration and motivation. I am forever thankful to have both of them in my life.

## TABLE OF CONTENTS

	<u>START PAGE</u>
<b>ABSTRACT</b>	<b>vii</b>
<b>PAPER 1 – <i>SUPPLY CHAIN PROCESS INTEGRATION: A CONCEPTUAL FRAMEWORK</i></b>	<b>1</b>
<b>PAPER 2 – <i>DEFINING AND OPERATIONALIZING SUPPLY CHAIN PROCESS INTEGRATION</i></b>	<b>48</b>
<b>PAPER 3 – <i>CUSTOMER ORIENTATION, SERVICE INNOVATIVE CAPABILITY, AND FIRM PERFORMANCE: IS SUPPLY CHAIN PROCESS INTEGRATION A MISSING LINK?</i></b>	<b>90</b>

## **ABSTRACT**

Through examining supply chain process integration conceptually and empirically, this study makes significant contributions to future research on integration which have important implications for managers.

The dissertation follows a three paper format. In the first conceptual paper, it is suggested that supply chain integration should be understood from an internal-external perspective and a process view. A conceptual model is proposed based on the strategy-structure-performance (SSP) framework and the resource based view (RBV) of firms. Firms' strategic orientations and decision-making structures are examined as key factors of supply chain process integration. Furthermore, it is argued that superior performance is likely to be achieved when necessary supply chain capabilities are developed through supply chain process integration.

The second paper focuses on defining and operationalizing the construct of supply chain process integration. An extensive literature review revealed no consensus in its conceptualization. With empirical support, it is proposed that internal and external supply chain process integration should be treated as two separate constructs, each comprised of two dimensions: connectivity and simplification.

The third paper takes a holistic approach to examining the role of supply chain process integration in the customer orientation–innovation–performance framework. Results of an empirical study indicate that supply chain process integration is the missing link between customer orientation and service innovative capability and that service innovative capability plays a critical role between supply chain process integration and firm performance. This study also empirically confirms the sequential link between internal process integration and external process integration.



# **SUPPLY CHAIN PROCESS INTEGRATION: A CONCEPTUAL FRAMEWORK**

## **INTRODUCTION**

As the concept of supply chain management (SCM) becomes more widely accepted, *supply chain integration* is gaining more attention among both practitioners and academics. While the positive outcomes of supply chain integration have been supported by previous research studies (e.g. Gimenez and Ventura 2003; Stank, Daugherty, and Ellinger 1999), effectively implementing integration remains a mystery for many companies. Operations of automobile companies such as Chrysler are more integrated than ever. Then why does a Dodge Ram pickup sit on a dealer's lot unsold for 237 days (Boudette 2007)? Dell has long been considered a superior example of supply chain integration, yet Dell has recently experienced difficulties in many operational areas and CEO Michael Dell admits that the company's supply chain needs to be improved and streamlined (Lee and Burrows 2007).

Achieving competitive advantage through supply chain integration has proven to be difficult both internally and externally (Fawcett and Cooper 2001; Fawcett and Magnan 2002). In an intra-firm context, Bowersox, Closs, and Stank (2000) indicated that while purchasing, production, logistics, and marketing have worked independently to integrate within their own functions, there has been less progress made toward cross-functional integration. Sabath and Whipple (2004) suggested that the reason is the "Great Operating Divide" – a significant gap in terms of management's ability to integrate their own internal functions. In an inter-firm context, Fawcett and Magnan (2002) found that most of the companies they studied were still at the early stages of

inter-company collaboration, because managers spent a significant amount of resources navigating the “waters of their own harbor” rather than forming external integrative programs.

Considering the suboptimal level of supply chain integration implementation, a better understanding is needed. An extensive literature review of SCM and logistics literature revealed the lack of even a clear understanding of the concept itself. Moreover, there is no comprehensive framework of supply chain integration. Although numerous studies have addressed the topic of supply chain integration, Pagell (2004) pointed out that study of the antecedents of integration is missing. Furthermore, the “black box” between supply chain integration and superior performance needs to be more fully examined. Therefore, the current study was undertaken to develop a comprehensive conceptual framework to address these research gaps. The goal is to investigate the antecedents and consequences of supply chain process integration with a clear conceptualization.

Specifically, the current study builds upon the theoretical foundation of strategy-structure-performance (SSP) framework and the resources based view (RBV) of firms. Synthesizing SSP and RBV provides a framework that is practical and meaningful to supply chain process integration practice and research. The current paper is structured as follows. The conceptualization of supply chain process integration is presented first, followed by a discussion of relevant theoretical background. Then the proposed conceptual model is introduced and propositions are developed. Finally, both academic and managerial implications are discussed.

## **UNDERSTANDING SUPPLY CHAIN PROCESS INTEGRATION**

As mentioned previously, integration has been recognized as a vital SCM concept. However, the meaning of supply chain integration has not been explained clearly and consistently. Without an explicit understanding, discussion and implementation of integration can be problematic. Thus, this section seeks to provide clarification of the concept of supply chain process integration. An extensive literature review suggested that an internal-external perspective and a process view of supply chain integration are critical.

### **Internal-External Perspective on Supply Chain Integration**

Although integration is often mentioned as a generic term without clearly defined boundaries, an internal-external perspective is essential to understanding the phenomenon. Early integration literature mainly focused on the activities *within* a firm. For example, in their seminal work, Lawrence and Lorsch (1967, p. 11) took an internal perspective and defined integration as “the quality of the state of collaboration that exists among departments that are required to achieve unity of effort by the demands of the environment.” Much of the SCM and logistics research has examined internal inter-functional integration, focusing on the interaction and collaboration between different departments (e.g. Ellinger, Daugherty, and Keller 2000; Kahn and Mentzer 1998). Another stream of research examined integration with external partners, highlighting the importance of buyer/seller cooperation for creating utility (e.g., Larson 1994). Internal and external integration should not be viewed as the same conceptually; they differ significantly in terms of scope and content. Different organizational ownerships and structures, participants, activities, and mechanisms require that internal and external

integration should be managed with different approaches. For example, integrating a firm's production process with an internal parts supplier would be significantly different from integrating an external parts supplier, because the parties involved in an external integration context often differ in terms of organizational policies, routines, values, and culture.

The fact that SCM is a boundary-spanning activity implies that both cross-functional and inter-organizational management efforts are important (Bowersox, Closs, and Stank 1999; Day 1994). Stevens (1989) emphasized that true supply chain integration includes both upstream and downstream players, although internal integration is the foundation. Internal integration can contribute to achieving reductions in costs, stock-outs, and lead time; and successful external integration is a necessity to achieve a strong competitive position (Gimenez and Ventra 2003). Thus, a firm is likely to obtain superior performance when achieving high levels of integration both internally and externally.

It can be concluded that internal and external integration are distinct but closely related concepts. Clearly, it is beneficial to examine *both* when studying supply chain integration (e.g. Morash and Clinton 1998; Rodrigues, Stank, and Lynch 2004; Stank, Keller, and Closs 2001). Clarifying the boundaries is not sufficient; an explicit understanding of the essence of supply chain integration is also fundamental.

### **Process View of Supply Chain Integration**

Process management is not new. The concept of organizing firm activities as business processes was introduced in the late 1980s and became popular in the early 1990s (Davenport 1993; Davenport, Hammer, and Metsisto 1989; Hammer and

Mangurian 1987). A business *process* refers to a structured and measured set of activities with specified business outcomes for customers (Davenport and Beers 1995). Zairi (1997, p. 64) further defined business process management as “a structured approach to analyze and continually improve fundamental activities such as manufacturing, marketing, communications and other major elements of a company’s operation.” The earliest process thinking has been attributed to pioneers of industrial engineering. Later, the process concept was adopted in the field of quality management and became the focus of corporate reengineering efforts (e.g. Davenport and Beers 1995). The critical differences between the traditional functions and the process approach are that the focus of every process is to meet customers’ requirements and the firm is organized around the processes (Cooper et al. 1997; Cooper, Lambert, and Pagh 1997).

Many of the best companies – 3M, Cisco, and Texas Instruments – have embraced a process management approach and become fast and flexible as a result (McCormack and Johnson 2001). While these success stories are encouraging, the complexity of business processes must be acknowledged. Business processes can vary significantly in terms of levels and scopes. SCM itself, in fact, can be considered a business process at the highest level and includes all activities involved in the supply chain. For example, Ross (1998) viewed supply chain process as the actual physical business functions, institutions, and operations that characterize the way a particular supply chain moves goods and services to market through the supply chain pipeline. At a lower level, a small set of activities employed to handle a customer’s defective product complaint is also a business process. Unless all the major business processes and

relevant sub-processes can be identified and understood explicitly, process management can be difficult to implement (cf. Lambert 2004). The process approach toward supply chain integration is best manifested in the Supply Chain Council's popular Supply Chain Operations Reference-model (SCOR) that suggests that business should be managed based on key processes – plan, source, make, deliver, and return (see [www.supply-chain.org](http://www.supply-chain.org)).

Hammer (2001) pointed out that it is in the integration of business processes across firms in the supply chain where the real “gold” can be found. Better managing business processes through process integration within and across members of the supply chain can make the transactions and relationship structures in the supply chain more efficient and effective (cf. Lambert 2004). Thus, Stock (2002) suggested that integration of processes within and between firms in the supply chain is the key to SCM success.

Based on the above discussed internal-external perspective and process view and existing conceptualization synthesis, *supply chain process integration* is defined here as the management of restructuring activities that aims at seamlessly linking relevant *business processes* and reducing redundant or unnecessary processes *within* and *across* firms. Having defined the key focal concept, the next section discusses the theoretical background to support the proposed model.

## **THEORETICAL BACKGROUND**

Logistics and SCM research as well as theory development can benefit from borrowing and applying existing theories from other disciplines (Stock 1997, 2002). In order to develop a theoretically solid conceptual model, the current study adopts, combines, and modifies two theoretical frameworks from the field of management,

namely the strategy-structure-performance (SSP) framework and the resource based view (RBV) of firms. The frameworks are particularly relevant to supply chain process integration because integration in essence is realigning structures to achieve optimal resource configuration.

### **Overview of the Frameworks**

The SSP framework has been widely used in the strategic management field. Chandler (1962) and Williamson (1970, 1975) related strategy to structure from the viewpoint of organizational design, economics, and sociology. The basic tenet of the SSP framework is that a firm's strategy drives the development of organizational structure and process (Galbraith and Nathanson 1978; Galunic and Eisenhardt 1994; Miles and Snow 1978). The fit between the strategy and structure of a firm leads to better performance because the structure provides the necessary systems and processes essential for successful strategy implementation (e.g. Grinyer, Yasai-Ardekani, and Al-Bazzaz 1980; Habib and Victor 1991).

Logistics and SCM researchers have not only adopted, but also expanded the SSP framework. For example, Defee and Stank (2005) extended SSP into the supply chain context based on Christopher's (1992) suggestion that competition is found at the supply chain level rather than the company level. Chow, Heaven, and Henriksson (1995) described the need for an appropriate organizational structure extending across firm boundaries to the whole supply chain and suggested that finding the best structure is contingent on the situation. Other researchers have linked supply chain strategy and structure to improved performance outcomes (e.g. Rodrigues, Stank, and Lynch 2004; Stank and Traichal 1998).

In spite of the empirical support of a positive relationship between strategy/structure fit and performance, a question still remains. Can a firm be assured of achieving better performance if its organizational structure fits its corporate strategy? Previous research has concluded that the alignment of strategy and structure is only a baseline requirement for organizational performance (Galbraith and Kazanjian 1986; Miles and Snow 1978). Miles and Snow (1984) also suggested that a minimal fit is required for firm survival. In other words, the fit of strategy and structure is a necessary but not sufficient condition for superior firm performance. So how can a firm turn strategy/structure fit into better performance? The RBV provides an explanation. It is suggested that the strategy and structure fit can only help improve performance by developing necessary capabilities. This argument is in line with Stock, Greis, and Kasarda's (1998) study, which linked a firm's strategy, structure, logistics capabilities, and performance.

Resource Based View (RBV) considers firms as bundles of distinct resources (Wernerfelt 1984). Firms are able to generate rents or competitive advantage by developing unique firm resources and capabilities (Barney 1991; Day 1994). Resources are stocks of available factors owned or controlled by a firm; while capabilities are a firm's capacity to deploy resources (Amit and Schoemaker 1993). Resources fall into two categories: tangible and intangible. Tangible resources include financial assets and physical assets (Grant 1991). Intangible resources include human capital resources (such as training, experience, intelligence, relationships, etc.) and organizational capital resources (such as reporting structure, planning, controlling and coordinating systems, etc.) (Barney 1991).



Researchers have long recognized the relevancy of RBV to logistics and SCM research. For example, Olavarrieta and Ellinger (1997) provided an in-depth review and discussion of RBV and proposed its application in strategic logistics research. Also, in an attempt to develop a unified theory of logistics, Mentzer, Min, and Bobbitt (2004) confirmed the link between resource management, logistics capabilities, and competitive advantage.

While these two theoretical frameworks (SSP and RBV) are not new to logistics and SCM researchers, the current study combines their basic tenets and applies them in the supply chain process integration context.

### **Applying SSP and RBV to supply chain process integration**

Both SSP and RBV frameworks are relevant to supply chain process integration because integration in essence is the structure realignment that focuses on optimal resource configuration. The SSP framework focuses on addressing the relationships among strategy, structure, and performance. Strategy refers to the “vital mission of an organization, the goals which must be attained, and the principal ways in which the resources available are to be used” (Hall and Saias 1980, p. 151). Strategy specifies how a firm seeks to achieve and maintain competitive advantage and is reflected in the firm’s strategic priorities. After identifying competitive priorities, firms allocate necessary resources and design appropriate structures and processes. Thus, firm’s strategic orientations can be considered strategy related variables.

Strategic priority develops from an awareness of opportunities and needs that create new administrative challenges, which may necessitate refashioned structures to operate the firm efficiently (Chandler 1962; Williamson 1970, 1975). Structure is how

tasks are allocated among organizational units and how decision-making authority is specified (Galbraith and Nathanson 1978). Organizational structure involves decisions relating to division of tasks, authority, and coordination mechanisms (Parthasarthy and Sethi 1992). The most studied organizational variables include formalization and centralization, and both are examined in the current study.

As the focus of the current study, supply chain process integration is the key concept that ties together the SSP and the RBV frameworks. First, supply chain process integration is considered as a structure-related variable in SSP. Structure is “the formal distribution of roles, and the administrative mechanisms which facilitate the control and integration of the different activities performed” (Hall and Saias 1980, p. 151). As such, structure is more than a planned network. It is also the process that takes place within and between the constituent parts. Internal process integration changes and defines the rules and routines that people need to follow; thus it is closely related to structure. Thompson (1967) suggested that external relationships have to be internalized and be considered as a part of organizational structure. Since external process integration involves relationships with external partners, it is also relevant to a firm’s organizational structure. In particular, the implementation of process integration involves the change or modification of a firm’s organizational structure. As an example, a firm may need to eliminate redundant distribution centers (DC’s) or consolidate them with customers’ DC’s while implementing integration.

The RBV framework is also relevant because the purpose of supply chain process integration is to better allocate resources within and across firms. Resources are the key input factor in the RBV framework, and acquiring a unique bundle of resources

is critical to a firm's success. Because structure can be viewed as the configuration of a firm's resources (Hall and Saias 1980), supply chain process integration can be considered the restructuring of activities and processes to help firms develop, allocate, and align resources to develop distinctive capabilities to generate better performance and competitive advantage.

Structure may not result in superior performance unless relevant capabilities are developed. In the current context, supply chain capabilities are the critical link. Supply chain related capabilities (such as responsiveness, cost reduction ability, etc.) are widely acknowledged as sources of competitive advantage (e.g., Lynch, Keller, and Ozment 2000; Morash, Dröge, and Vickery 1996a; Olavarrieta and Ellinger 1997; Zhao, Dröge, and Stank 2001).

Based on the discussion above, it can be concluded that both SSP and RBV are relevant and can serve as a solid theoretical foundation for understanding the supply chain process. Next, the proposed conceptual model is presented and the development of propositions is discussed in detail.

## **CONCEPTUAL FRAMEWORK**

In order to provide a useful framework to help managerial implementation and research, a conceptual model of supply chain process integration is developed based on SSP and RBV premises (see Figure 1). Supply chain process integration is important. However, very few supply chains are fully integrated, but portions are often integrated. Integration starts at the firm level, then across firms, and on to the supply chain level. The current conceptual model is at the firm level, but examines both internal and external process integration.

**FIGURE 1**  
**A CONCEPTUAL MODEL**

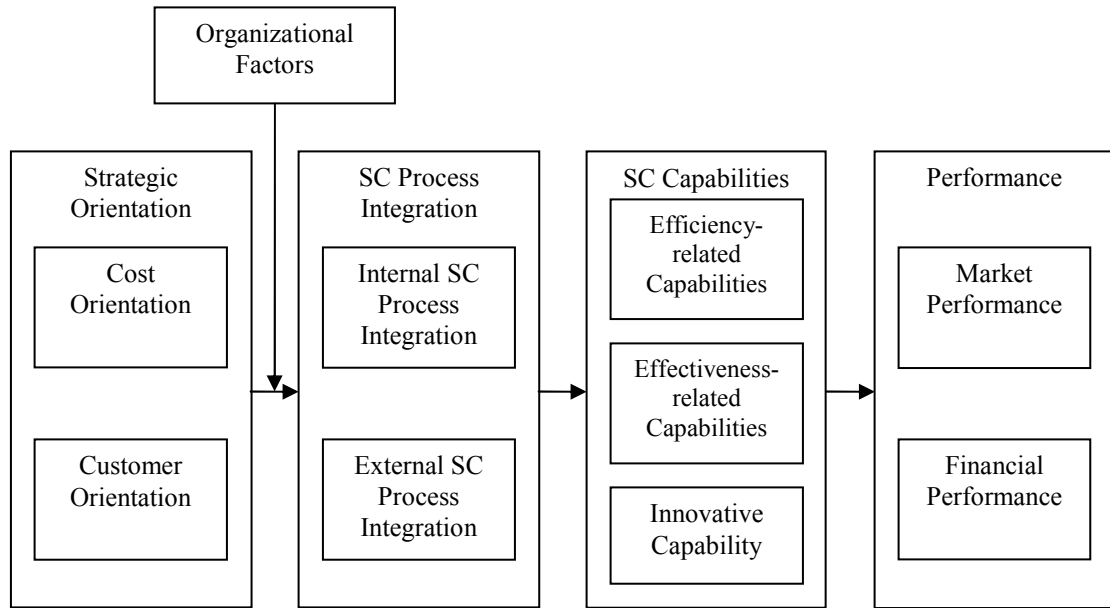

**Strategic Orientation and Supply Chain Process Integration**

Strategy is a major organizational plan for action to reach a major organizational objective (Higgins and Vincze 1989). In other words, strategy influences and directs the conduct of business activities (Porter 1996). Strategic orientation is the specific approach a firm chooses to implement its strategies for the purpose of creating superior and continuous performance (Gatignon and Xuereb 1997). Thus, *strategic orientation* is a reflection of a firm’s strategy and provides explicit goals for the firm’s activities, including the supply chain process integration activities.

The focus is on the strategic orientations closely related to supply chain process integration. Based on an extensive review of trade publications, two types strategic orientation emerged as most critical to implementing supply chain process integration – cost orientation and customer orientation.

### ***Cost orientation and supply chain process integration***

Many firms focus on cost as a competitive priority (Porter 1980; Stock, Greis, and Kasarda 1998). *Cost orientation* is a type of corporate culture that focuses on seeking and exploiting all sources of cost advantage (Porter 1985). Firms pursuing a low cost strategy emphasize tight cost controls in business processes, such as inventory management, materials handling, and production efficiencies, coupled with minimal cost investments in R&D, service, and marketing (Martin and Grbac 2003). Cost minimization becomes the overriding priority (Parthasarthy and Sethi 1993). Some companies pursue lower costs to the point where they ignore customers' needs. One example is that many companies switched their call centers to overseas to take advantage of cheap local labor (Friedman 2005). Although achieving lower costs, customer service levels were compromised because of the communication difficulties created by cultural and language differences.

However, cost orientation can encourage firms to implement supply chain process integration. Cost behavior of a value activity cannot be understood by examining that activity alone. Additionally, managing activities with an isolated approach is not enough; rather, a firm needs to take an overall approach and consider the interactions between different processes. Both internal and external linkages between processes should be considered, because joint optimization and coordination of activities within and across firms provide a powerful source of cost advantage. In other words, process integration presents a superior opportunity for firms to achieve cost advantage because redundancies can be reduced and efficiency can be improved (Grant 1991). In fact, examination of trade publications on integration revealed that many firms embraced

integration with the sole emphasis on cost reduction (e.g. *Automotive Industries* 2002; Richardson 2005). Thus, in order to achieve the maximum cost reduction, firms often choose to implement supply chain process implementation for the purpose of streamlining business processes and reducing redundancies and duplication. For example, General Motors wants to cut costs by reducing suppliers to about 500 and the goal is to develop more integrative relationships with fewer suppliers (*The Times* 2006). Hence,

***Proposition 1.*** A firm's cost orientation has direct positive impact on its supply chain process integration.

### ***Customer orientation and supply chain process integration***

Customer orientation has been defined as “the sufficient understanding of one’s target buyers to be able to create superior value for them continuously” (Narver and Slater 1990, p. 21). Deshpande, Farley, and Webster (1993, p27) defined customer orientation as “the set of beliefs that puts the customer’s interest first, while not excluding those of all other stakeholders such as owners, managers, and employees, in order to develop a long-term profitable enterprise.” Thus, *customer orientation* in the current study is defined as a corporate culture that focuses on understanding customer needs and continuously creating customer value.

Researchers have highlighted the importance of customer orientation and consider customer orientation the most fundamental aspect of a corporate culture (e.g. Deshpande, Farley, and Webster 1993; Lawton and Parasuraman 1980). The Council of Supply Chain Management Professionals (CSCMP) explicitly includes customers as an important component of SCM and emphasizes that the objective of SCM is to meet customer requirements. Lambert (2004) also stressed that the goal of SCM is to add

value for customers and other stakeholders. Although customer often refers to a firm's direct customers in marketing relationship studies, the current study suggests that it is not sufficient to only accommodate the needs of direct customers. A company should consider all downstream supply chain partners (especially the end consumers) as its customers; all customers are integral to the supply chain (Lee 2004). Thus, a customer orientation requires that a seller understand a buyer's entire value chain (Day and Wensley 1988).

It is posited that customer orientation enhances internal supply chain process integration. The SSP framework suggests that a firm's strategic direction develops from an awareness of opportunities and needs (Chandler 1962). However, a firm may need to restructure operations to implement a chosen strategy. When a firm fully embraces customer orientation as its strategic priority, all functional activities and organizational processes need to be focused toward anticipating and responding to changing market and customer requirements ahead of competitors. Researchers have suggested that the implementation of customer orientation naturally leads to integrating all functions (Felton 1959). To be more specific, creating value for customers involves the synergistic efforts of the entire business and not merely of a single department or function in it (Narver and Slater 1990; Webster 1988). Researchers, thus, have argued that the coordinated integration of the business's resources in creating superior value for customers is tied closely to customer orientation (Narver and Slater 1990; Wind and Robertson 1983). In reality, firms often use cross-functional teams to manage various processes in order to meet customer needs rather than managing each function independently. This parallels the underlying rationale of Bowersox, Closs, and Stank's

(1999, p. 59) definition of internal integration: “the competency of linking internally performed work into a seamless process to support customer requirements.” Firms with strong customer orientation are likely to implement Customer Relationship Management (CRM) programs. In an extensive literature review, Landry, Arnold, and Arndt (2005) proposed that structures and processes within organizations often need to be restructured and integrated in order to implement CRM. For example, it might be necessary to redesign the personal selling process to better integrate it with other sales and support activities of the firm or redesign and align incentive structure across the firm.

Customer orientation also facilitates external supply chain process integration. First, customer orientation can create better information visibility. According to Narver and Slater (1990), a seller must understand not only the cost and revenue dynamics of its immediate customer, but also the relevant dynamics of the customer’s customer (Day and Wensley 1988). This kind of understanding and communication enables supply chain participants to identify the interfaces that need to be connected and the duplicate processes that can be eliminated. Second, customer orientation fosters collaborative external relationships. With a strong customer orientation, a firm is more likely to develop customer closeness as a distinctive capability (Day 1994), and traditional transactional buyer-seller relationships are likely to be replaced with collaborative relationships. Collaborative relationships could facilitate the connection and simplification of business processes cross firm boundaries. Furthermore, because customer orientation places the highest priority on continuously finding ways to provide superior customer value, an increased commitment to customer orientation should result in increased boundary-spanning activity (Han, Kim, and Srivastava 1998; Pierce and



Delbecq 1977). In a third-party logistics service context, Sinkovics and Roath's (2004) empirical study supported the argument that customer orientation can increase the propensity toward coordination and combination of operational processes and procedures. Thus,

***Proposition 2.*** A firm's customer orientation has direct positive impact on its supply chain process integration.

### ***Combining cost orientation and customer orientation***

While a firm's cost orientation and customer orientation each impacts supply chain process integration, the current paper argues that when combined together their impact will be more significant.

Obsession with cost and negligence of customers can yield disastrous results. For example, big auto companies have vowed to integrate their supply chains, but some results fell short of expectations. So-called "orphan" vehicles sit on the dealers' lots for months. Chrysler equipped a truck model with a V6 engine instead of the V8 requested by most big truck buyers. Another orphan Jeep Grand Cherokee with four-wheel drive, a feature popular in snowy climates, could not find an owner in Florida. One Chrysler Sebring convertible was so loaded with options that it had a sticker price of \$32,000—nearly as much as a BMW 3 Series. Chrysler had 128,688 vehicles in unsold inventory at the end of 2006. This was equivalent to 102 days of sales, a half a year's output of a truck plant, or \$4.3 billion in potential revenue. Rather than build cars to suit customer tastes, U.S. auto makers churn out what makes sense for their plants, and then use incentives and rebates to lure buyers (Baudette 2007). The reason? Although these companies' production processes are highly integrated across various internal functional

areas and with external suppliers and distributors, overlooking and excluding final consumers underscores the reality that their supply chains are not truly integrated.

Experience has shown that the lowest cost distributor is not always (in fact, not often) the most successful (Mentzer 1993). Lee (2004) identified pitfalls of supply chains purely focusing on low cost. First, cost-orientation often results in too much inventory at the end of the supply chain because products manufactured purely according to economy of scale often do not sell well. That's why department stores sell as much as a third of their merchandise at discounted prices. Second, firms' obsession with low cost may cause supply chains to break down easily with little buffer inventory. Third and more important, low-cost supply chains often become uncompetitive because they cannot adapt to changes in the structure of market, including unexpected changes in demand or supply.

Firms need to apply cost orientation principles and also be customer focused. A widely accepted trade-off in supply chain management is balancing costs and customer service (Cooper and Ellram 1993; Houlihan 1985; Jones and Riley 1985). While providing high customer service levels is desirable, the cost can be formidable. Thus, a strong cost orientation can help firms keep their supply chain activities within a feasible range.

Collaborative Planning, Forecasting and Replenishment (CPFR) is an excellent example of combining both cost orientation and customer orientation. By integrating sales forecasting and replenishment processes between trading partners, CPFR enables participants to share improvements in both inventory costs and customer service (Esper

and Williams 2003). Based on the preceding discussion, the following proposition is offered.

***Proposition 3.*** Effectively combining cost and customer orientation can have optimal impact on a firm's supply chain process integration.

### **Effects of Traditional Organizational Factors**

Some researchers have suggested that structure is an important moderator, but not sufficient in and of itself to prompt higher performance (Child 1972; Harris and Ruefli 2000). For example, while general SSP literature examines organizational structure variables' direct impacts on firm performance, Child (1972, p. 12) suggested that "structural design is likely to have only a limited effect upon the organizational performance achieved." Schwenk and Shrader (1993) also suggested variables other than structure (formalization in their study) may play important roles. Similarly, it is suggested that traditional organizational structure variables do not have a direct impact on supply chain process integration. Rather, it is proposed that the relationship between strategic orientations and supply chain process integration is moderated by two frequently studied traditional organizational factors – centralization and formalization.

#### ***Centralization***

*Centralization* refers to the degree to which employees are involved in decision making organization wide, the extent to which workers are encouraged to critically evaluate and report problems, and worker empowerment (Dalton et al. 1980; Miller and Dröge 1986). In other words, in a centralized organization, power is retained in upper levels of the organizational hierarchy or concentrated within a few positions (John and Martin 1984). The opposite of centralization is decentralization.

Studies have yielded different conclusions on centralization depending on the situation. Centralization tends to be advantageous when economies of scale are important or when the environment is very hostile or controlling (Mintzberg 1979). A certain level of centralization is necessary; excessive decentralization will generally result in a series of incoherent separate plans (Hall and Saias 1980). Researchers have argued that centralization leads to greater effectiveness due to the ability of the decision maker to plan, coordinate, and control activities (Hage 1965; Pugh et al. 1968). On the other side, decentralization may make it difficult to avoid chaos, inconsistency, and duplicate efforts, especially within large, complex organizations (Adler 1999).

Decentralization tends to be more appropriate when the environment is complex (Mintzberg 1979) and when there is need for quick decision making (Daft 2001; Osborn et al., 1985). Excessive centralization can lead to inflexibility and a lack of confidence among those who have the best knowledge of the environment (Hall and Saias 1980). In addition, the alienation and dissatisfaction due to excessive centralization may result in lower-than-expected outcomes (John and Martin 1984). Decentralization of operations management through self-managed work teams inspires employee motivation, loyalty, and creativity. Thus, Senge (1994) argued that a structurally more effective organization involves dramatically decreasing vertical complexity while increasing horizontal complexity. The specific approach is role empowerment through decentralization.

The effects of centralization differ based on the type of decision involved. Baum and Wally's (2003) empirical study demonstrated the positive outcomes of centralization of strategic decisions and decentralization of operational decisions. It is proposed that this rationale also applies to the moderating effects of centralization on the link between

a firm's strategic orientation and its supply chain process integration. A firm's strategic level decisions are better concentrated at the top level to ensure the effective coordination of strategic moves related to integration. On the other side, decentralized operational decisions can facilitate responsive actions needed in integration. This is consistent with the results of previous studies. For example, Claycomb, Dröge, and Germain (1999) found that integration is linked with decentralization of operational decisions; while Germain, Dröge, and Daugherty's (1994) research in a Just-In-Time (JIT) context found organizational integration and centralization of more strategically important decisions are likely to be achieved at the same time. As such, the following proposition can be made.

***Proposition 4.*** The relationship between a firm's strategic orientation and its supply chain process integration is moderated by

- (1) the level of centralization of its strategic decisions, and
- (2) the level of decentralization of its operational decisions.

### ***Formalization***

As another key structure variable in traditional SSP framework, *formalization* is the degree to which formal rules and procedures govern decisions and working relationships (Olson, Slater, and Hult 2005). A formalized organization places emphasis on following specific rules and procedures in carrying out plan formulation, including documentation of planning activities and adherence to job descriptions (John and Martin 1984).

As with centralization, the effects of formalization are complex. Formal rules and procedures can lead to increased efficiency and lower administrative costs (Ruekert, Walker, and Roering 1985; Walker and Ruekert 1987), particularly in stable environments or those in which tasks are comparatively simple and/or repetitive (Hage

1965; Olson, Walker, and Ruekert 1995; Pugh et al. 1968). John and Martin (1984) argued that formalization can be beneficial because it signals a commitment by the organization to certain activities, thus conveying the importance and value of these activities. A meta-analysis of studies of small firms found that formalized planning enhanced performance (Schwenk and Shrader 1993). Removal of formal organization structures takes away organizational memory, systems for application of important management skills, and the benefit of experience formalized in systems (Adler and Borys 1996; Shah 2000).

Formalization may be viewed as negative when it leads to inadequate interaction and undesired conformity in planning and implementation (Mintzberg 1979). Higher levels of formalization may also be associated with negative reactions in terms of satisfaction, autonomy, and challenge (e.g., Aiken and Hage 1968; Pierce and Dunham 1978; Rousseau 1978). Formalization can detract from organization performance because it inhibits adaptability, open communication, and rapid competitive response (e.g. Khandwalla 1977). Firms with fewer formal procedures encourage horizontal and vertical communication and flexible roles, resulting in benefits such as rapid awareness and response to competitive and market change, more effective information sharing, and reduced lag time between decision and action (Miles and Snow 1992). Daft (2004) equated formalized control systems to bureaucracy and suggested it should be replaced with adaptive cultures and clan controls to facilitate information sharing and collaboration.

Despite different opinions, studies have suggested that formalization decisions should be based on the type of task. The widely accepted conclusion is that routine tasks

need to be formalized and non-routines should be less formalized (Adler and Borys 1996; Baum and Wally 2003). In a supply chain process integration context, routine tasks include procedures and steps that are performed regularly without significant variation. Adler (1999) suggested that TQM programs, such as ISO 9000, can generate positive outcomes by formalizing routine tasks and relationships. Rodrigues, Stank, and Lynch (2004) suggested that internal integration is likely to be achieved by lower levels of formalization of non-routine tasks – encouraging front-line managers and employees to use discretion.

Thus, formalization can be proposed to have the following moderating effects.

***Proposition 5.*** The relationship between a firm’s strategic orientation and its supply chain process integration is moderated by

- (1) the level of formalization of its routine tasks, and
- (2) the level of informalization of its non-routine tasks.

### **Supply Chain Process Integration and Supply Chain Capabilities**

The proposed conceptual model suggests that supply chain process integration does not necessarily result in desired superior performance unless relevant supply chain capabilities are developed. According to RBV, creating capabilities is not simply a matter of assembling resources: capabilities involve complex patterns of coordination between people and other resources (Grant 1991). Researchers have linked process and capability closely. Day (1994, p. 38) stated that “capabilities and organizational processes are closely entwined.” His definition of capability further confirmed the close association between process and capability – “Capabilities are complex bundles of skills and collective learning, exercised through organizational processes, that ensure superior coordination of functional activities” (p. 38). Amit and Schoemaker (1993) also noted that the development of capabilities involves effective management and utilization of

organizational processes, because capabilities are embedded in organizational routines and can be achieved through cooperation and coordination (Grant 1991). As a set of restructuring activities, supply chain process integration can help a firm realign processes and resources more effectively, thus contributing to the development of certain critical supply chain capabilities. This is in line with Day's (1994) argument from a RBV perspective – if a firm is more proficient with its process management than its rivals through process integration, this represents a distinctive capability, which can directly lead to superior profitability. The relationship between process integration and supply chain related capabilities is explored next.

### ***Process integration and efficiency/effectiveness-related capabilities***

Researchers have argued that supply chain capabilities can become distinctive and represent a powerful source of competitive advantage due to the unique boundary-spanning nature (Bowersox and Closs 1996; Morash, Dröge, and Vickery 1996b; Olavarrieta and Ellinger 1997). Considerable effort has been made to identify the dimensions of supply chain capabilities (e.g. Fawcett, Stanley, and Smith 1997; Morash, Dröge, and Vickery 1996a, 1996b; Zhao, Dröge, and Stank 2001). Most of the studied supply chain capabilities to date fall into two categories: *efficiency-related capabilities* and *effectiveness-related capabilities*. *Efficiency-related capabilities* refer to a firm's ability to utilize resources (i.e. minimize costs), while *effectiveness-related capabilities* are a firm's ability to fulfill customer requirements (i.e. enhance customer service) (Mentzer 1993). This categorization parallels Morash, Dröge, and Vickery's (1996a, 1996b) terminology of supply-management interface capabilities (including channels of distribution, total cost minimization, and lowest cost distribution) and demand-



management interface capabilities (including product or service differentiation and service enhancement).

Studies have shown that integration can help firms develop efficiency-related capabilities. More specifically, process integration can contribute to cost reduction by waste reduction and more effective management of the processes. Gustin, Stank, and Daugherty (1994) found that integrated firms are more likely to computerize their business processes, thus achieving significant tangible benefits including substantial inventory savings and lead time reductions. Maloni and Benton (2000) found that buyer-seller integration can help firms achieve cost savings from the following areas: economies of scale (in ordering, production, and transportation), decreased administration costs, decreased switching costs, and improved asset utilization. Electric Data Interchange (EDI), a type of technology that facilitates integration of various processes across firms through information sharing, has been found to be associated with shorter cycle time (Sutton 1997), inbound shipment quality (Walton and Maruchek 1997), and lower costs (Sutton 1997). Process integration also ensures that operational interfaces within and between firms are synchronized to reduce duplication, redundancy, and dwell time (Rodrigues, Stank, and Lynch 2004), thus helping firms develop efficiency capabilities.

A firm's effectiveness-related capabilities can also be positively impacted by process integration. In order to satisfy customers in a volatile environment, an increasing number of firms consider prompt reaction to changes as a priority (Daugherty, Stank, and Rogers 1996). Internal process integration can help firms develop effectiveness-related capabilities to respond the changing customer demands. A firm's responsiveness

to customers requires the support of integrated logistics processes (Daugherty, Sabath, and Rogers 1992), because where there is a lack of integration, sub-optimization with inevitable conflict between departments and activities tends to be the norm (Stuade 1987). Closs and Savitskie (2003) further found that internal logistics information technology integration can significantly improve the firm's responsiveness to key customers and delivery time flexibility. Zara, a Spanish clothing company, provides a great example of how processes integration helps achieve a sustainable competitive advantage by improving responsiveness to customer needs (Heinrich and Simchi-Levi 2005). Stank, Daugherty, and Ellinger (1999) found that highly integrated firms outperform low integration firms by developing superior capability in meeting key customers' needs and accommodating special customer service requests.

Similarly, external process integration can also contribute to the development of a firm's effectiveness-related capabilities. According to Bagchi and Skjoett-Larsen (2002), supply chain integration encourages partners to become more entrenched members of the supply chain by instilling a sense of belonging. The enhanced trust and commitment among supply chain members enable them to work closely to address changes in the market. One good example is the process integration with third party logistics providers (3PL). Logistics resources and expertise are core competencies of 3PLs, but not for many manufacturers, technology companies, and retailers (Boyson, Corsi, and Rabinovich 1999). Integrating with 3PLs allows firms to better respond to changing customer needs. In addition, through both internal and external process integration, firms are able to quickly draw inputs and skill sets from various functional areas. This may lead to higher problem-solving creativity and thus reduce product

development cycle time (Griffin 1997), which means the firm's higher ability to respond to market changes and to satisfy customers.

***Proposition 6a.*** A firm's supply chain process integration has positive impact on its efficiency-related capabilities.

***Proposition 6b.*** A firm's supply chain process integration has positive impact on its effectiveness-related capabilities.

### ***Process Integration and supply chain related innovative capability***

In addition to the above discussed efficiency/effectiveness-related capabilities, it is proposed that supply chain process integration also impacts another type of important but often overlooked supply chain capability – innovative capability. As technology advances and consumers become both more sophisticated and more demanding, the life cycles of market offerings are shrinking at a record pace. In order to remain competitive in the fast-changing environment, more and more companies have realized the critical importance of innovation. Thompson (1965, p. 36) defined innovation as “the generation, acceptance and implementation of new ideas, processes, products, or services.” Zaltman, Duncan, and Holbek (1973) defined innovation as “an idea, practice or material artifact perceived as new by the relevant unit of adoption” (p. 2); Amabile et al. (1996) indicated innovation is the “successful implementation of creative ideas within an organization” (p. 25). Although innovation may be defined very broadly, including technology, product, services, processes, or any social system (Flint et al. 2005), the research on innovation has largely focused on new product-related breakthroughs (Han, Kim, and Srivastava 1998). As services become a more important differentiator (Christopher 2005), service innovation has gained attention (e.g. Berry et al. 2006). Although researchers have advocated its critical importance to SCM (e.g. Fawcett, Stanley, and Smith 1997; Flint et al. 2005), service innovation in the supply chain

context has not received much research attention and little has been written (Flint et al. 2005). The emphasis here is *innovative capability*, which is defined as a firm's ability to develop and offer new services or processes to create superior value for supply chain members.

In the innovation literature, Khan (1996) suggested that interdepartmental integration can promote product innovation. Other studies have shown that focusing simultaneously on supplier and customer integration can contribute to product innovation (Frohlich and Westbrook 2001; Koufteros, Vonderemse, and Jayaram 2005). Stank, Daugherty, and Ellinger (1999) also found that highly integrated firms outperform low integration firms in the area of accommodating new product introductions.

Similarly, process integration can significantly contribute to a firm's supply chain related innovative capability. While researchers have argued that customer orientation could enhance innovation (e.g., Han, Kim, and Srivastava 1998; Hurley and Hult 1998), it is suggested that process integration can be a critical facilitator. Argyris (1982) suggested that organizational participants typically face uncertainty in dealing with innovations, coupled with the absence of preestablished rules or procedures. In such situations, process integration helps mitigate distrust and conflicts among the functional units, which in turn provides an environment more receptive to innovations (Han, Kim, and Srivastava 1998). Numerous studies have suggested that an interfunctional relationship that fosters trust and dependence can help a firm achieve organizational innovativeness through interfunctional coordination (Argyris 1982; Gupta, Raj, and Wilemon 1986; Olson, Walker, and Ruckert 1995; Ruckert and Walker 1987; Zaltman, Duncan, and Holbek 1973). Through close interactions between different parties, process

integration requires a firm to develop a thorough understanding of the operations along the supply chain, which provides a solid knowledge foundation for supply chain innovative capability. Furthermore, process integration enables cross-fertilization and stimulation of ideas through shared knowledge and experiences among different functional areas and partnering firms. Each party brings a different interpretation of the same data as well as different and complementary data to the process, thus facilitating active learning (Flint et al., 2005). Therefore, a strong supply chain related innovative capability is more likely to be developed through process integration.

***Proposition 7.*** A firm's supply chain process integration has positive impact on its supply chain related innovative capability.

### **Supply Chain Capabilities and Performance**

The RBV framework suggests that by developing distinctive capabilities a firm can establish a competitive advantage, which is reflected in its performance (Barney 1991). *Performance* in general is the extent to which a firm's goals are achieved (Ellinger, Daugherty, and Keller 2000). The focus here is to examine a firm's overall performance in terms of market performance and financial performance, which indicate the firm's success level. A firm's market performance includes both market share and customer satisfaction. While market share is a good indicator of the firm's competitiveness in the marketplace, customer satisfaction reflects customers' value perception. Because of the significant economic worth of loyal customers (Cannon and Homburg 2001; Reichheld and Sasser 1990), a firm's success in the marketplace rests on the firm's ability to attract, satisfy, and retain customers by creating customer value (Johnson 1998). Economic theories suggest that achieving economic rents is the goal of

any firm. Thus, measures such as profitability, sales volume, return on asset (ROA), etc. should be used to evaluate a firm's financial performance.

When a firm develops distinctive supply chain capabilities through supply chain process integration, it is likely to achieve competitive advantage in the market (Day 1994; Olavarrieta and Ellinger 1997), and result in bigger market share. Efficiency-related capabilities focus on cost reduction, which in turn directly contributes to better financial performance. Effectiveness-related capabilities such as availability, timeliness, and quality centers on customers and thus can positively impact customers' value perception. Customer satisfaction can also result when efficiency capabilities can be converted into lower cost for customers. Satisfying customers through value creation helps a firm's bottom line (Cannon and Homburg 2001; Reichheld and Sasser 1990). The link between supply chain capabilities and firm performance has been supported by numerous studies. For example, Zhao, Dröge, and Stank (2001) found logistics capabilities enhance customer satisfaction and return on assets. Sinkovics and Roath (2004) argued that firms with high level of flexibility are able to make accommodation to take advantage of unexpected situations and to continue creating value for customers. The reason is that supply chain capabilities such as flexibility can be manifested through a firm's ability to redeploy assets to take advantage of opportunities and/or avoid problems (Grewal and Tansuhaj 2001), thus enhance firm performance (Evans 1991). Similarly, Daugherty, Ellinger, and Rogers (1995) found that customer responsiveness can significantly enhance performance.

In addition to widely studied efficiency/effectiveness-related capabilities, a firm's supply chain related innovative capability can also significantly contribute to

organizational performance improvement (Han, Kim, and Srivastava 1998; Hult, Hurley, and Knight 2004). RBV (Wernerfelt 1984) helps to explain how firms derive competitive advantage by channeling resources into the development of new products, processes, and so forth. As market environment changes, firms must adopt innovations over time and the most important innovations are those allowing the firm to achieve some sort of competitive advantage, thereby contributing to its performance (Hult, Hurley, and Knight 2004). Innovative capability rooted in process integration involves complex development procedures and knowledge contributions from various parties within and outside a firm, making it a superior distinctive capability. Das and Joshi (2007) found a significant and positive relationship between a firm's innovativeness and its financial performance. Automaker Saturn's service parts supply chain, one of the best in the industry, is an example of how innovative capability can directly contribute to a firm's performance. By fully integrating the stocking and replenishment processes with its dealers, Saturn created a unique service parts supply process – monitoring and managing parts inventory for its dealers. The result? Customer loyalty because of the high service level – the service parts same-day availability is 94% at Saturn, compared to the industry average of 70 - 80% (Lee 2004). Therefore, it can be proposed that

***Proposition 8a.*** A firm's efficiency-related capabilities have positive impact on its performance.

***Proposition 8b.*** A firm's effectiveness-related capabilities have positive impact on its performance.

***Proposition 8c.*** A firm's innovative capabilities have positive impact on its performance.

## **IMPLICATIONS**

The current study makes significant contributions by introducing a comprehensive conceptual model of supply chain process integration, which emphasizes a process view and an internal-external perspective. The proposed model brings disparate research streams and concepts together to further the understanding of supply chain process integration. The propositions associated with the conceptual model are rooted in an extensive literature review and synthesis and have important implications to both researchers and practitioners.

### **Theoretical Implications**

The current study lays a solid theoretical foundation for future integration research by combining and modifying two widely used theoretical frameworks – SSP and RBV. It is suggested that the essential tenets of SSP and RBV complement each other and provide a stronger and more complete scheme to understand the phenomenon of supply chain process integration. The resulting conceptual model has important implications for future research.

First, the current study examines a firm's strategic orientations as crucial antecedents of supply chain process integration. Two types of strategic orientations – cost orientation and customer orientation – are identified as the key drivers of supply chain process integration. It is also argued that the interaction of these two strategic orientations has the maximum effect on supply chain process integration. While Pagell (2004) suggested the lack of research on the antecedents of integration, the proposed conceptual model offers a new venue to study supply chain process integration. Besides



the identified orientations in the model, future research may examine the impacts of firms' other business orientations on supply chain process integration.

Second, in line with the suggestions of earlier researchers (e.g., Child 1972; Harris and Ruefli 2000), the current study argues that traditional organizational structure factors should not be treated as direct drivers of firm performance or integration. Structure itself cannot guarantee desired outcomes. Thus, it is suggested that conventional organizational factors – centralization and formalization – only have moderating effects on the link between strategic orientations and supply chain process integration. Future empirical research is needed to validate or modify this proposition.

Third, the traditional SSP framework suggests that structure has direct impact on performance and existing studies have suggested the direct positive link between supply chain integration and performance. However, the current study argues that supply chain process integration is the restructuring activities that target at realigning resources within and across firms, thus linking the SSP and RBV frameworks. Combining the tenets of these two theoretical frameworks provides much stronger explanatory power than applying the frameworks individually. Thus, how supply chain process integration can improve a firm's performance and competitive advantage can be better understood with the proposed model.

Even with the above mentioned contributions, the proposed conceptual model is not without limitations. First, the current model uses individual firms as the unit of analysis. This is due to the current status of SCM, i.e., very few organizations have the ability or insights to manage their entire supply chains. As SCM practices progress, a more meaningful framework based on network theory is warranted. Also, the proposed

relationships still need empirical support. While testing the entire model in one study is a formidable task, continuous effort should be taken to test groups of the links.

### **Managerial Implications**

Supply chain managers can benefit from the current study in various ways. First, the proposed conceptual model suggests that a firm's strategic orientations have significant impact on its supply chain process integration practices. While firms with either cost orientation or customer orientation may adopt the concept of supply chain integration, it is suggested that the *effective combination of these two* will generate optimal results. Neglecting either one may lead to suboptimal outcomes – supply chain process integration may end up with unexpected results such as the hard-to-sell Chrysler vehicles. In reality, many leading companies are adjusting their supply chain practices and moving overseas call centers back home. Their experience suggests that purely focusing on low cost through the extensive use of cheap overseas call centers may jeopardize customer service.

Second, although the importance of customer orientation has long been advocated, many non-marketing managers still believe that it is the marketing manager's responsibility to really care about customers. Without direct contact or interaction with customers, many managers in other areas still view customer orientation as a remote and irrelevant concept. Even firms that aspire to become customer oriented oftentimes find it is difficult to implement, because they underestimate how challenging it is to shift an organization's focus to both internal and external concerns (Day 1994). However, the proposed conceptual model suggests that the implementation of supply chain process integration, encompassing various functional areas within and across firms, requires the

incorporation of customer orientation in every step. Only when customer orientation is instilled and sustained can supply chain process integration create value for customers and yield the desired financial outcomes for the firm.

Third, the proposed conceptual model suggests that internal process integration and external process integration should be differentiated, but managed cohesively. Although supply chain process integration involves both concepts, it is not wise to treat them with a single approach. For example, although information exchange is widely recognized as a key factor that facilitates process integration information sharing within a firm and across firm boundaries can differ significantly. Even with close partners, necessary actions need to be taken to protect proprietary information.

Fourth, although this study proposes that organizational structural factors (such as centralization and formalization) do not necessarily directly lead to supply chain process integration, their facilitating role still deserves serious consideration. In particular, in order to achieve the desired level of supply chain process integration, a firm's strategic decisions need to be centralized and operational or routine tasks need to be formalized. The key is to find the optimal balancing point where process integration can be implemented without creating organizational structural obstacles.

## REFERENCES

- Adler, Paul S. (1999), "Building Better Bureaucracies," *Academy of Management Executive*, Vol. 13, No. 4, pp. 36-47.
- Adler, Paul S. and Bryan Borys, (1996), "Two Types of Bureaucracy: Enabling and Coercive," *Administrative Science Quarterly*, Vol. 41, No. 1, pp. 61-89.
- Aiken, M. and J. Hage (1968), "Organizational Independence and Intra-organizational Structure," *American Sociological Review*, Vol. 33, pp. 912-930.
- Amabile, Teresa M., Regina Conti, Heather Coon, Jeffrey Lazenby, and Michael Herron (1996), "Assessing the Work Environment for Creativity," *Academy of Management Journal*, Vol. 39, No. 5, pp. 1154-1184.
- Amit, Raphael and Paul J.H. Schoemaker (1993), "Strategic Assets and Organizational Rent," *Strategic Management Journal*, Vol. 14, No. 1, pp. 33-46.
- Argyris, Chris (1982), *Reasoning, Learning, and Action: Individual and Organizational*, San Francisco, CA: Jossey-Bass.
- Automotive Industries (2002), "Sourcing Strategy Helps Suppliers/OEMs," May, Vol.182, No. 5, p. 14.
- Bagchi, Prabir K. and Tage Skjoett-Larsen (2002), "Organizational Integration in Supply Chains: A Contingency Approach," *Global Journal of Flexible Systems Management*, Vol. 3, No. 1, pp. 1-10.
- Barney, Jay (1991), "Firm Resources and Sustained Competitive Advantage," *Journal of Management*, Vol. 17, No. 1, pp. 99-120.
- Baum, J. Robert and Stefan Wally (2003), "Strategic Decision Speed and Firm Performance," *Strategic Management Journal*, Vol. 24, No. 2, pp. 1107-1129.
- Berry, Leonard L., Venkatesh Shankar, Janet Turner Parish, Susan Cadwallader, and Thomas Dotzel (2006), "Creating New Markets through Service Innovation," *MIT Sloan Management Review*, Vol. 47, No. 2, pp. 56-63.
- Boudette, Neal E. (2007), "Lots of Vehicles Big Dealer to Detroit: Fix How You Make Cars," *Wall Street Journal*, Vol. CCXLIX No. 33 (February 9, 2007), pp. A1 and A8.
- Boyson, Sandor, Thomas Corsi, and Elliot Rabinovich (1999), "Managing Effective Third Party Logistics Relationships: What Does It Take?" *Journal of Business Logistics*, Vol. 20, No. 1, pp. 73-100.

- Bowersox, Donald J. and David J. Closs (1996), *Logistics Management: The Integrated Supply Chain Process*, New York, NY: McGraw-Hill.
- Bowersox, Donald J., David J. Closs, and Theodore P. Stank (1999), *21<sup>st</sup> Century Logistics: Making Supply Chain Integration A Reality*, Oak Brook, IL: Council of Logistics Management.
- Bowersox, Donald J., David J. Closs, and Theodore P. Stank (2000), "Ten Mega-Trends That Will Revolutionize Supply Chain Logistics," *Journal of Business Logistics*, Vol. 21, No. 2, pp. 1-16.
- Cannon, Joseph P. and Christian Homburg (2001), "Buyer-Supplier Relationships and Customer Firm Costs," *Journal of Marketing*, Vol. 65, No. 1, pp. 29-43.
- Chandler, Alfred D. (1962), *Strategy and Structure*, Cambridge, MA: MIT Press.
- Child, J. (1972), "Organizational Structure, Environment, and Performance: The Role of Strategic Choice," *Sociology*, Vol. 6, pp. 1-22.
- Chow, Garland, Trevor D. Heaver, and Lennart E. Henriksson (1995), "Strategy, Structure and Performance: A Framework for Logistics Research," *Logistics and Transportation Review*, Vol. 3, No. 4, pp. 285-308.
- Christopher, Martin L. (2005), *Logistics and Supply Chain Management*, London, UK: Prentice Hall.
- Claycomb, Cindy, Cornelia Droge, and Richard Germain (1999), "The Effect of Just-in-Time with Customers on Organizational Design and Performance," *International Journal of Logistics Management*, Vol. 10, No. 1, pp. 37-58.
- Closs, David J. and Katrina Savitskie (2003), "Internal and External Logistics Information Technology Integration," *International Journal of Logistics Management*, Vol. 14, No. 1, pp. 63-76.
- Cooper, Martha C. and Lisa M. Ellram (1993), "Characteristics of Supply Chain Management and the Implications for Purchasing and Logistics Strategy," *International Journal of Logistics Management*, Vol. 4, No. 2, pp. 13-24.
- Cooper, Martha C., Lisa M. Ellram, John T. Gardner, and Albert M. Hanks (1997), "Meshing Multiple Alliances," *Journal of Business Logistics*, Vol. 18, No. 1, pp. 67-89.
- Cooper, Martha C., Douglas M. Lambert and Janus D. Pagh (1997), "Supply Chain Management: More Than a New Name for Logistics," *International Journal of Logistics Management*, Vol. 8, No. 1, pp. 1-14.

Daft, Richard L. (2001 and 2004), *Essentials of Organization Theory and Design*, Cincinnati, OH: South-Western College.

Dalton, Dan R., William D. Todor, Michael J. Spendolini, Gordon J. Fielding, and Lyman W. Porter (1980), "Organizational Structure and Performance: A Critical Review," *Academy of Management Review*, Vol. 5, pp. 49-64.

Das, Sidhartha R. and Maheshkumar P. Joshi (2007), "Process Innovativeness in Technology Services Organizations: Roles of Differentiation Strategy, Operational Autonomy and Risk-Taking Propensity," *Journal of Operations Management*, No. 25, Vol. 3, pp. 643-660.

Daugherty, Patricia J., Alexander E. Ellinger, and Dale S. Rogers (1995), "Information Accessibility: Customer Responsiveness and Enhanced Performance," *International Journal of Physical Distribution & Logistics Management*, Vol. 25, No. 1, pp. 4-17.

Daugherty, Patricia J., Robert E. Sabath, and Dale S. Rogers (1992), *Logistics and Transportation Review*, Vol. 28, No. 3, pp. 257-271.

Daugherty, Patricia J., Theodore P. Stank, and Dale S. Rogers (1996), "Third-Party Logistics Service Providers: Purchasers' Perceptions," *International Journal of Purchasing and Materials Management*, Vol. 32, No. 2, pp. 7-16.

Davenport, Thomas H. (1993), "Reengineering the Corporation," *Sloan Management Review*, Vol. 35, No. 1, pp. 103-104.

Davenport, Thomas H and Michael C. Beers (1995), "Managing Information about Processes," *Journal of Management Information Systems*, Vol. 12, No. 1, pp. 57-80.

Davenport, Thomas H., Michael Hammer, and Tauno J. Metsisto (1989), "How Executives Can Shape Their Company's Information Systems," *Harvard Business Review*, Vol. 67, No. 2, pp. 130-134.

Day, George S. (1994), "The Capabilities of Market-Driven Organizations," *Journal of Marketing*, Vol. 58, No. 4, pp. 37-52.

Day, George S. and Robin Wensley (1988), "Assessing Advantage: A Framework for Diagnosing Competitive," *Journal of Marketing*, Vol. 52, No. 2, pp. 1-20.

Defee, C. Clifford and Theodore P. Stank (2005), "Applying the Strategy-Structure-Performance Paradigm to the Supply Chain Environment," *International Journal of Logistics Management*, Vol. 16, No. 1, pp. 28-50.

Deshpande, Rohit, John U. Farley, and Frederick E. Webster, Jr. (1993), "Corporate Culture, Customer Orientation, and Innovativeness," *Journal of Marketing*, Vol. 57, No. 1, pp. 23-37.

- Ellinger, Alexander E., Patricia J. Daugherty, and Scott B. Keller (2000), "The Relationship between Marketing/Logistics Interdepartmental Integration and Performance in U.S. Manufacturing Firms: An Empirical Study," *Journal of Business Logistics*, Vol. 21, No.1, pp. 1-22.
- Esper, Terry L. and Lisa R. Williams (2003), "The Value of Collaborative Transportation Management (CTM): Its Relationship to CPFR and Information Technology," *Transportation Journal*, Vol. 42, No. 4, pp. 55-65.
- Evans, J. Stuart (1991), "Strategic Flexibility for High Technology Maneuvers: A Conceptual Framework," *Journal of Management Studies*, Vol. 28, No. 1, pp. 69-89.
- Fawcett, Stanley E. and M. Bixby Cooper (2001), "Process Integration for Competitive Success: Benchmarking Barriers and Bridges," *Benchmarking*, Vol. 8, No. 5, pp. 396-412.
- Fawcett, Stanley E., Linda L. Stanley, and Sheldon R. Smith (1997), "Developing a Logistics Capability to Improve the Performance of International Operations," *Journal of Business Logistics*, Vol. 18, No. 2, p. 101-127.
- Fawcett, Stanley E. and Gregory M. Magnan (2002), "The Rhetoric and Reality of Supply Chain Integration," *International Journal of Physical Distribution & Logistics Management*, Vol. 32, No. 5, pp. 339-351.
- Felton, Arthur P. (1959), "Making the Marketing Concept Work," *Harvard Business Review*, Vol. 37, No. 4, pp. 55-65.
- Flint, Daniel J., Everth Larsson, Britta Gammelgaard, and John T. Mentzer (2005), "Logistics Innovation: A Customer Value-Oriented Social Process," *Journal of Business Logistics*, Vol. 26, No. 1, pp. 113-147.
- Friedman, Thomas L. (2005), *The World Is Flat: A Brief History of the Twenty-first Century*, New York, NY: Farrar, Straus and Giroux.
- Frohlich, Markham T. and Roy Westbrook (2001), "Arcs of Integration: An International Study of Supply Chain Strategies," *Journal of Operations Management*, Vol. 19, No. 2, pp. 185-200.
- Galbraith, Jay R. and Robert K. Kazanjian (1986), *Strategy Implementation: Structure, System, and Process*, St Paul, MN: West Publishing Company.
- Galbraith, Jay R. and Daniel A. Nathanson (1978), *Strategy Implementation: The Role of Structure and Process*, St Paul, MN: West Publishing Company.

- Galunic, D. Charles and Kathleen M. Eisenhardt (1994), "Renewing the Strategy-Structure-Performance Paradigm," *Research in Organizational Behavior*, Vol. 16, pp. 215-255.
- Gatignon, Hubert and Jean-Marc Xuereb (1997), "Strategic Orientation of the Firm New Product Performance," *Journal of Marketing Research*, Vol. 34, No. 1, pp.-77-90.
- Germain, Richard, Cornelia Dröge, and Patricia J. Daugherty (1994), "The Effects of Just-In-Time Selling on Organizational Structure: An Empirical Investigation," *Journal of Marketing Research*, Vol. 31. No.4, pp. 471-483.
- Gimenez, Cristina and Eva Ventura (2003), "Supply Chain Management as a Competitive Advantage in the Spanish Grocery Sector," *International Journal of Logistics Management*, Vol. 14, No. 1, pp. 77-88.
- Grant, Robert M. (1991), "The Resource-Based Theory of Competitive Advantage: Implications for Strategy Formulation," *California Management Review*, Vol. 33, pp. 114-135.
- Grewal, Rajdeep and Patriya Tansuhaj (2001), "Building Organizational Capabilities for Managing Economic Crisis: The Role of Market Orientation and Strategic Flexibility," *Journal of Marketing*, Vol. 65, No. 2, pp. 67-80.
- Griffin, Abbie (1997), "The Effect of Project and Process Characteristics on Product Development Cycle Time," *Journal of Marketing Research*, Vol. 34, Winter, pp. 24.
- Grinyer, Peter H., Masoud Yasai-Ardekani, and Shawki Al-Bazzaz (1980), "Strategy, Structure, the Environment, and Financial Performance in 48 United Kingdom Companies," *Academy of Management Journal*, Vol. 23, No. 2, pp. 193-220.
- Gupta, Ashok K., S. P. Raj, and David.A. Wilemon (1986), "Model for Studying R&D-Marketing Interface in the Product Innovation Process," *Journal of Marketing*, Vol. 50, No. 2, pp. 7-17.
- Gustin, Craig M, Theodore P. Stank, and Patricia J. Daugherty (1994), "Computerization: Supporting Integration," *International Journal of Physical Distribution & Logistics Management*, Vol. 24, No. 1, pp. 11-16.
- Habib, Mohammed M. and Bart Victor (1991), "Strategy, Structure, and Performance of U.S. Manufacturing and Service MNCs: A Comparative Analysis," *Strategic Management Journal*, Vol. 12, No. 8, pp. 589-606.
- Hage, Jerald (1965), "An Axiomatic Theory of Organizations," *Administrative Science Quarterly*, Vol. 10, No. 3, pp. 289-320.



- Hall, Robert W. (1987), *Attaining Manufacturing Excellence*, Homewood, IL: Dow Jones-Irwin.
- Hall, David J. and Maurice A. Saias (1980), "Strategy Follows Structure!" *Strategic Management Journal*, Vol. 1, No. 2, pp. 149-163.
- Hammer, Michael (2001), "The Superefficient Company," *Harvard Business Review*, Vol. 79, No. 8, pp. 82-91.
- Hammer, Michael and Glenn E. Mangurian (1987), "The Changing Value of Communications Technology," *Sloan Management Review*, Vol. 28, No. 2, pp. 65-71.
- Han, Jin K., Namwoon Kim, and Rajendra K. Srivastava (1998), "Market Orientation and Organization Performance: Is Innovation a Missing Link?" *Journal of Marketing*, Vol. 62, No. 4, pp. 30-45.
- Harris, Ira C. and Timothy W. Ruefli (2000), "The Strategy/Structure Debate: An Examination of the Performance Implications," *Journal of Management Studies*, Vol. 37, No. 4, pp. 587-603.
- Heinrich, Claus E. and David Simchi-Levi (2005), "Do IT Investments Really Pay Off?" *Supply Chain Management Review*, Vol. 9, No. 4, pp. 22-28.
- Higgins, James M. and Julian W. Vincze (1989), *Strategic Management: Text and Cases, 4<sup>th</sup> Edition*, Chicago, IL: Dryden Press.
- Houlihan, John B. (1985), "International Supply Chain: A New Approach," *International Journal of Physical Distribution and Materials Management*, Vol. 15, No. 1, pp. 22-38.
- Hult, G. Thomas M., Robert F. Hurley, and Gary A. Knight (2004), "Innovativeness: Its Antecedents and Impact on Business Performance," *Industrial Marketing Management*, Vol. 33, pp. 429-438.
- Hurley, Robert F. and G. Thomas M. Hult (1998), "Innovation, Market Orientation, and Organizational Learning: An Integration and Empirical Examination," *Journal of Marketing*, Vol. 62, No. 3, pp. 42-54.
- John, George and John Martin (1984), "Effects of Organizational Structure of Marketing Planning on Credibility and Utilization of Plan Output," *Journal of Marketing Research*, Vol. 21, No. 2, pp. 170-183.
- Johnson, M. Eric (1998), "Giving'em What They Want," *Management Review*, Vol. 87, No. 1, pp. 62-67.

- Jones, Thomas C. and Daniel W. Riley (1985), "Using Inventory for Competitive Advantage through Supply Chain Management," *International Journal of Physical Distribution and Materials Management*, Vol. 15, No. 5, pp. 16-26.
- Kahn, Kenneth B. (1996), "Interdepartmental Integration: A Definition with Implications for Product Development Performance," *Journal of Product Innovation Management*, Vol. 13, pp. 137-151.
- Kahn, Kenneth B. and John T. Mentzer (1998), "Marketing's Integration with Other Departments," *Journal of Business Research*, Vol. 42, No. 1, pp. 53-62.
- Khandwalla, Pradip N. (1977), *The Design of Organizations*, New York, NY: Harcourt Brace and Jovanovich.
- Koufteros, Xenophon, Mark Vonderemse, and Jayanth Jayaram (2005), "Internal and External Integration for Product Development: The Contingency Effects of Uncertainty, Equivocality, and Platform Strategy," *Decision Science*, Vol. 36, No. 1, pp. 97-133.
- Lambert, Douglas M. (2004), *Supply Chain Management: Processes, Partnerships, Performance*, Sarasota, FL: Supply Chain Management Institute.
- Landry, Timothy D., Todd J. Arnold, and Aaron Arndt (2005), "A Compendium of Sales-Related Literature in Customer Relationship Management: Processes and Technologies with Managerial Implementations," *Journal of Personal Selling & Sales Management*, Vol. 25, No. 3, pp. 231-251.
- Larson, Paul D. (1994), "An Empirical Study of Inter-organizational Functional Integration and Total Costs," *Journal of Business Logistics*, Vol. 15, No. 1, pp. 153-169.
- Lawrence, Paul R. and Jay Williams Lorsch (1967), *Organization and Environment: Managing Differentiation and Integration*, Boston, MA: Graduate School of Business Administration, Harvard University.
- Lawton, Leigh and A. Parasuraman (1980), "The Impact of the Marketing Concept on New Product Planning," *Journal of Marketing*, Vol. 44, No. 1, pp. 19-25
- Lee, Hau L. (2004), "The Triple-A Supply Chain," *Harvard Business Review*, Vol. 82, No. 10, pp. 102-111.
- Lee, Louise and Peter Burrows (2007), "Is Dell Too Big for Michael Dell?" *BusinessWeek*, No. 4021 (February 12, 2007), pp. 33.
- Lynch, Daniel F., Scott B. Keller, and John Ozment (2000), "The Effects of Logistics Capabilities and Strategy on Firm Performance," *Journal of Business Logistics*, Vol. 21, No. 2, pp. 47-67.

- Maloni, Michael and W.C. Benton (2000), "Power Influences in the Supply Chain," *Journal of Business Logistics*, Vol. 21, No. 1, pp. 49-63.
- Martin, James H. and Bruno Grbac (2003), "The Effects of Supplier Focus, Customer Responsiveness and Strategy Type on Growth in a Transition Economy," *Journal of Marketing Theory and Practice*, Vol. 11, No. 2, p. 43-55.
- McCormack, Kevin and Bill Johnson (2001), "Business Process Orientation, Supply Chain Management, and the E-Corporation," *IIE Solutions*, Vol. 33, No. 10, p33-37.
- Mentzer, John T. (1993), "Managing Channel Relations in the 21st Century," *Journal of Business Logistics*, Vol. 14, No. 1, pp. 27-42.
- Mentzer, John T., Soonhong Min, and L. Michelle Bobbitt (2004), "Toward to Unified Theory of Logistics," *International Journal of Physical Distribution & Logistics Management*, Vol. 34, No. 8, pp. 606-627.
- Miles, Raymond E. and Charles C. Snow (1978), *Organizational Strategy, Structure, and Process*, New York, NY: McGraw-Hill.
- Miles, Raymond E. and Charles C. Snow (1984), "Designing Strategic Human Resources Systems," *Organizational Dynamics*, Vol. 13, No. 1, pp. 36-52.
- Miles, Raymond E. and Charles C. Snow (1992), "Causes of Failure in Network Organizations," *California Management Review*, Vol. 34, No. 4, pp. 53-72.
- Miller, Danny and Cornelia Dröge (1986), "Psychological and Traditional Determinants of Structure," *Administrative Science Quarterly*, Vol. 31, No. 4, pp. 539-560.
- Mintzberg, Henry (1979), *The Structuring of Organizations*, Englewood Cliffs, NJ: Prentice-Hall.
- Morash, Edward A. and Steven R. Clinton (1998), "Supply Chain Integration: Customer Value through Collaborative Closeness versus Operational Excellence," *Journal of Marketing Theory and Practice*, Vol. 6, No. 4, pp. 104-120.
- Morash, Edward A., Cornelia .L.M. Dröge, and Shawnee K. Vickery (1996a), "Strategic Logistics Capabilities for Competitive Advantage and Firm Success," *Journal of Business Logistics*, Vol. 17, No. 1, pp. 1-21.
- Morash, Edward A., Cornelia .L.M. Dröge, and Shawnee K. Vickery (1996b), "Boundary Spanning Interfaces between Logistics, Production, Marketing and New Product Development," *International Journal of Physical Distribution & Logistics Management*, Vol. 26, No. 8, pp. 43-62.

- Narver, John C. and Stanley F. Slater (1990), "The Effect of a Market Orientation on Business Profitability," *Journal of Marketing*, Vol. 54, No. 4, pp. 20-35.
- Olavarrieta, Sergio and Alexander E. Ellinger (1997), "Resource-Based Theory and Strategic Logistics Research," *International Journal of Physical Distribution & Logistics Management*, Vol. 27, No. 9/10, pp. 559-587.
- Olson, Eric M., Stanley F. Slater, and G. Thomas M. Hult (2005), "The Performance Implications of Fit among Business Strategy, Marketing Organization Structure, and Strategic Behavior," *Journal of Marketing*, Vol. 69, No. 3, pp. 49-65.
- Olson, Eric M., Orville C. Walker, and Robert W. Ruekert (1995), "Organizing for New Product Development: The Moderating Role of Product Innovativeness," *Journal of Marketing*, Vol. 59, No. 1, pp. 48-62.
- Osborn, Richard N., James G. Hunt, and Lawrence R. Jauch (1985), *Organizational Theory: Integrated Text and Case*, Melbourne, FL: Krieger.
- Pagell, Mark (2004), "Understanding the Factors That Enable and Inhibit the Integration of Operations, Purchasing and Logistics," *Journal of Operations Management*, Vol. 22, No. 5, pp. 459-487.
- Parthasarthy, Raghavan and S. Prakash Sethi (1992), "The Impact of Flexible Automation on Business Strategy and Organizational Structure," *Academy of Management Review*, Vol. 17, No. 1, pp.86-111.
- Parthasarthy, Raghavan and S. Prakash Sethi (1993), "Relating Strategy and Structure to Flexible Automation: A Test of Fit and Performance Implications," *Strategic Management Journal*, Vol. 14, No. 7, pp. 529-549.
- Pierce, Jon L. and Randall B. Dunham (1978), "An Empirical Demonstration of the Convergence of Common Macro- and Micro-Organization Measures," *Academy of Management Journal*, Vol. 21, pp. 410-418.
- Porter, Michael E. (1980), *Competitive Strategy: Techniques for Analyzing Industries and Competitors*. New York, NY: The Free Press.
- Porter, Michael E. (1985), *Competitive Advantage: Creating and Sustaining Superior Performance*, New York, NY: The Free Press.
- Porter, Michael E. (1996), "What Is Strategy?" *Harvard Business Review*, Vol. 74, No. 6, pp. 61-78.
- Pugh, D. S., D. J. Hickson, C. R. Hinings, and C. Turner (1968), "Dimensions of Organization Structure," *Administrative Science Quarterly*, Vol. 13, No. 1, pp. 65-105.

- Reichheld, Frederick F. and W.Earl Sasser (1990), "Zero Defections: Quality Comes to Services," *Harvard Business Review*, Vol. 68, No. 5, pp. 105-111.
- Richardson, Helen L. (2005), "Shape up Your Supply Chain," *Logistics Today*, Vol. 46, No. 1, pp. 26-29.
- Rodrigues, Alexander M., Theodore P. Stank, and Daniel F. Lynch (2004), "Linking Strategy, Structure, Process and Performance in Integrated Logistics," *Journal of Business Logistics*, Vol. 25, No. 2, pp. 65-94.
- Ross, David Frederick (1998), *Competing Through Supply Chain Management*, New York, NY: Chapman & Hall.
- Rousseau, Denise M. (1978), "Characteristics of Departments, Positions and Individuals: Context for Attitudes and Behavior," *Administrative Science Quarterly*, Vol. 23, No. 4, pp. 521-540.
- Ruekert, Robert W. and Orville C. Walker (1987), "Marketing's Interaction with Other Functional Units: A Conceptual Framework and Empirical Evidence," *Journal of Marketing*, Vol. 51, No. 1, pp. 1-19.
- Ruekert, Robert W. and Orville C. Walker, and Kenneth J. Roering (1985), "The Organization of Marketing Activities: A Contingency Theory of Structure and Performance," *Journal of Marketing*, Vol. 49, No. 1, pp. 13-25.
- Sabath, Robert and Judith Whipple (2004), "Using the Customer/Product Action Matrix to Enhance Internal Collaboration," *Journal of Business Logistics*, Vol.25, No.2, pp. 1-19.
- Schwenk, Charles R. and Charles B. Shrader (1993), "Effects of Formal Strategic Planning on Financial Performance in Small Firms: A Meta-Analysis," *Entrepreneurship Theory and Practice*, Vol. 17, No. 3, pp. 53- 64.
- Senge, Peter M. (1994), *The Fifth Discipline*, New York NY: Doubleday.
- Shah, Priti Pradhan (2000), "Network Destruction: The Structural Implications of Downsizing," *Academy of Management Journal*, Vol. 43, No. 1, pp. 101-112
- Sinkovics, Rudolf R. and Anthony S. Roath (2004), "Strategic Orientation, Capabilities, and Performance in Manufacturer-3PL Relationships," *Journal of Business Logistics*, Vol. 25, No. 2, pp. 43-64.
- Stank, Theodore P., Scott B. Keller, and David J. Closs (2001), "Performance Benefits of Supply Chain Logistical Integration," *Transportation Journal*, Vol. 41, No. 2/3, pp. 32-46.

- Stank, Theodore P., Patricia J. Daugherty, and Alexander E. Ellinger (1999), "Marketing/Logistics Integration and Firm Performance," *International Journal of Logistics Management*, Vol. 10, No. 1, p. 11-24.
- Stank, Theodore P. and Patrick A. Traichal (1998), "Logistics Strategy, Organizational Design, and Performance in a Cross-boarder Environment," *Logistics and Transportation Review*, Vol. 31, No. 1, pp. 75-86.
- Stevens, Graham C. (1989), "Integrating the Supply Chain," *International Journal of Physical Distribution & Materials Management*, Vol. 19, No. 8, pp. 3-8.
- Stock, Gregory N., Noel P. Greis, and John D. Kasarda (1998), "Logistics, Strategy and Structure: A Conceptual Framework," *International Journal of Operations & Production Management*, Vol. 18, No. 1, pp. 37-52.
- Stock, James R. (1997), "Applying Theories from Other Disciplines to Logistics," *International Journal of Physical Distribution & Logistics Management*, Vol. 27, No. 9/10, pp. 515-539.
- Stock, James R. (2002), "Marketing Myopia Revisited: Lessons for Logistics," *International Journal of Physical Distribution & Logistics Management*, Vol. 32, No. 1/2, pp. 12-21.
- Stuade, Gavin E. (1987), "The Physical Distribution Concept as a Philosophy of Business," *International Journal of Physical Distribution & Logistics Management*, Vol. 17, No. 6, pp. 32-37.
- Sutton, Mathias J. (1997), "The Role of Electronic Data Interchange in the Transportation Industry: Part 1," *Defense Transportation Journal*, Vol. 53, No. 4, pp. 10-12.
- The Times (2006), "GM Hopes to Reduce Supplier Numbers," June 26, p. 39.
- Thompson, James D. (1967), *Organizations in Action*, New York, NY: McGraw Hill.
- Thompson, Victor A. (1965), "Bureaucracy and Innovation," *Administrative Science Quarterly*, Vol. 5, pp. 1-20.
- Walker, Orville C. and Robert W. Ruekert (1987), "Marketing's Role in the Implementation of Business Strategies: A Critical Review and Conceptual Framework," *Journal of Marketing*, Vol. 51, No. 3, pp. 15-33.
- Walton, Steven V. and Ann S. Maruchek (1997), "The Relationship between EDI and Supplier Reliability," *International Journal of Purchasing and Materials Management*, Vol. 40, No. 3, pp. 55-79.

Webster, Frederick E., Jr. (1988), "Rediscovering the Marketing Concept," *Business Horizons*, Vol. 31, No. 3, pp. 29-39.

Wernerfelt, Birger (1984), "A Resource-Based View of the Firm," *Strategic Management Journal*, Vol. 5, No. 2, pp. 171-80.

Williamson, Oliver E. (1970), *Corporate Control and Business Behavior: An Inquiry into the Effects of Organization Form on Enterprise Behavior*, Englewood Cliffs, N.J.; Prentice Hall.

Williamson, Oliver E. (1975), *Markets and Hierarchies, Analysis and Antitrust Implications: A Study in the Economics of Internal Organization*, New York, NY: Free Press.

Wind, Yoram and Thomas S. Robertson (1983), "Marketing Strategy: New Directions for Theory and Research," *Journal of Marketing*, Vol. 47, No. 2, pp. 12-25.

Zhao, Meng, Cornelia L.M. Dröge, and Theodore P. Stank (2001), "The Effects of Logistics Capabilities on Firm Performance: Customer-Focused Versus Information-Focused Capabilities," *Journal of Business Logistics*, Vol. 22, No. 2, pp. 91-107.

Zairi, Mohamed (1997), "Business Process management: A Boundaryless Approach to Modern Competitiveness," *Business Process Re-engineering & Management Journal*, Vol. 3, No. 1, pp. 64-80.

Zaltman, Gerald, Robert Duncan, and Jonny Holbel (1973), *Innovations and Organizations*, New York, NY: John Wiley & Sons.

# DEFINING AND OPERATIONALIZING SUPPLY CHAIN PROCESS INTEGRATION

## INTRODUCTION

The importance of integration to supply chain management (SCM) has been widely recognized and is explicitly indicated by SCM definitions. For example, Cooper, Lambert, and Pagh (1997, p. 1) define SCM as “the *integration* of key business processes from end users through original suppliers that provides products, services, and information that add value for customers and other stakeholders.” Similar emphasis on integration can also be seen in the Council of Supply Chain Management Professionals’ (CSCMP) definition: “In essence, Supply Chain Management *integrates* supply and demand management within and across companies.” While research on supply chain integration continues to grow, an extensive literature review reveals issues still exist. First, there is no clear and widely accepted definition of integration. Many studies on integration do not even clearly define the concept. While the basic concept of integration may be familiar to most researchers, the actual conceptualizations and operationalizations of the construct vary a great deal (Pagell 2004). Second, although researchers have studied integration from different angles and different scopes, little research has been done to identify the true essence of integration applicable to different settings. Third, a close examination of integration operationalizations indicates that existing measures for integration-related constructs do not match well with related conceptualizations. Scale validity is often questionable, because many of the existing integration scale items can be used to measure other constructs. These problems may impede the development of supply chain integration research. Thus, the current study



was undertaken to provide a robust and accurate conceptualization of integration and to develop a valid and parsimonious operationalization.

The current paper is organized as follows. Relevant literature is first reviewed and synthesized, followed by a qualitative study. Then, the resultant definition and operationalization are tested and assessed using empirical data. The conclusion and implications are presented last.

### **CONCEPTUALIZING SUPPLY CHAIN PROCESS INTEGRATION**

According to the Merriam-Webster Dictionary (2007), *integrate* means “to form, coordinate, or blend into a functioning or unified whole,” and *integration* is “the act or process or an instance of integrating.” In early business research, integration often referred to vertical integration approach. Integration in this manner was based upon the make-or-buy decision under the explanation of Transaction Cost Analysis (TCA) (Coase 1937; Williamson 1975). With TCA, functions within firms were brought together to decrease costs; this was the objective. Integration, on the other hand, suggests that the firms’ objective is to increase functional efficiencies in order to achieve cost benefits.

Given the recognition that potentially greater benefits are achieved through coordination among firms, current SCM is often based on cooperation among independent entities and not on the legal or financial ownership by firms. Thus, new meanings have been attributed to integration. The results of a review of the literature indicate that despite the large amount of research on integration, the construct does not have a single, accepted definition or operationalization (Pagell 2004). Additionally, integration is frequently equated to other concepts such as collaboration or coordination (e.g., Barratt and Oliveira 2001; Ross 2002). A summary of various definitions and

proposed dimensions/types/stages of integration in the fields of marketing, management, and logistics is shown in the Appendix A.

Integration is such a broad term that it can be used to describe a wide variety of linkages between departments and firms. For example, internally or externally, firms can integrate different elements of their operations. These elements may be tangible (such as product flows, measurement, etc.) or intangible (such as relationships, information, etc.). The wide potential of integration topics has not only offered a wealth of knowledge but also introduced a great deal of complexity. Managers may question what type of integration should be focused on, what actions should be taken, when different types of integration overlap, and what procedures should be followed. Therefore, a simple but meaningful definition of integration is needed for more effective research and management efforts. Ideally, this definition could serve as an overarching guide for all integration activities and be applied to different settings.

It should be noted that the various definitions and operationalizations share common themes and tend to overlap (Pagell 2004). After a thorough analysis of existing literature on integration, it was concluded that an internal-external perspective and a process view are fundamental to the conceptualization of supply chain integration.

### **An Internal-External Perspective**

Although previous studies have identified different types and dimensions of integration, it is suggested that the boundaries of integration should first be identified. Here boundary refers to the ownership of business processes and activities. Different ownerships require different approaches to integration implementation. Without clearly

defining the boundaries, it is difficult to understand and address the issues involved in internal and external integration. Therefore, an internal-external perspective is necessary.

Internal integration occurs within a firm. Lawrence and Lorsch (1967, p. 11) defined integration as “the quality of the state of collaboration that exists among departments that are required to achieve unity of effort by the demands of the environment.” Researchers have examined integration between various areas such as R&D and marketing (Ayers, Dahlstrom, and Skinner 1997), manufacturing and purchasing (Narasimhan and Das 2001), marketing with R&D and manufacturing (Kahn and McDonough 1997; Kahn and Mentzer 1998), marketing and manufacturing (O’Leary-Kelly and Flores 2002; Prabhaker, Goldhar, and Lei 1995; Verma et al. 2001), human resource management and manufacturing (Pagell, Handfield, and Barber 2000; Youndt et al. 1996). Research on inter-functional integration has been focused on interaction and collaboration between different departments (e.g. Ellinger, Daugherty, and Keller 2000; Kahn and Mentzer 1998).

External integration occurs between a firm and its external partners, which highlights the importance of buyer/seller cooperation for creating utility (e.g. Larson 1994). Barratt and Oliveira (2001) proposed that integration occurs when two or more companies share the responsibility of exchanging common planning, management, execution, and performance measurement information. Backward and forward integration (Fawcett and Magnan 2002) and customer and supplier integration (Stank, Keller, and Closs 2001; Stank and Lackey 1997) all fall into this category.

Since interactions and collaboration occur both within and across firms, some researchers have examined internal and external integration at the same time (e.g.

Morash and Clinton 1998; Rodrigues, Stank, and Lynch 2004). Because of SCM's boundary-spanning features, both internal and external integration are important (Bowersox, Closs, and Stank 1999). Furthermore, it is proposed that internal and external integration should be treated as different concepts. The reasons are two-fold. First, because there are significant differences among exchange partners in many respects (such as organizational ownership, structure, policies, value, etc.), the participants, activities, mechanisms, and scope involved in internal and external integration differ considerably. Thus, the internal-external perspective has important implications. For example, information exchange, a critical facilitator of integration, can vary significantly within a firm and across firm boundaries. Even with close partners, most firms will take steps to protect proprietary information.

Second, although both are important to a firm's success, internal and external integration are often achieved at uneven levels. Research has identified different sequential orders of internal and external integration. For example, on one hand, Stevens (1989) suggested that internal integration comes first and is the foundation of external integration. On the other hand, many managers have reported that it is easier for buyers to integrate with their suppliers and logistics managers to integrate with their customers than it is for either group to integrate within the firm, across logistics, procurement, manufacturing, and marketing. This is due to what Sabath and Whipple (2004) identified as a significant gap in terms of management's ability to integrate their own internal functions – the great operating divide. Differences exist in the implementation levels of internal and external integration.

## **A Process View**

SCM is the integration of key business processes from end users through original suppliers that provide products, services, and information that add value for customer and other stakeholders (Lambert 2004). Thus, a process view of supply chain integration is fundamental. A business *process* refers to a structured and measured set of activities with specified business outcomes for customers (Davenport and Beers 1995). Zairi (1997, p. 64) further defined business process management as “a structured approach to analyze and continually improve fundamental activities such as manufacturing, marketing, communications and other major elements of a company’s operation.” The process paradigm implies a new way of looking at organizations based on the processes they perform rather than on the functional units, divisions, or departments they are divided into (Cooper et al. 1997; Cooper, Lambert, and Pagh 1997; Trkman et al. 2007). The focus of the traditional functional approach was often associated with myopic view of the activity’s influence upon other activities within or between firms. The process approach broadens the focus of the organization. This focus allows activities to interact to creating value in meeting customers’ needs.

Process management does not necessarily lead to the ideal level of integration, because a firm might manage each business process separately. However, it is argued that only when a company takes a process view, can it effectively integrate both internally and externally. This is considered key to SCM success (Stock 2002). The reason is that implementing business processes within and across members of the supply chain makes the transactions and relationship structures in the supply chain more efficient and effective (cf. Lambert 2004). In fact, researchers have linked integration

with process management. For example, Lambert (2004) and McAdam and McCormack (2001) suggested that a process approach is an effective means to integrate corporate functions within the firm. Hammer (2001) also pointed out that it is in the integration of business processes across firms in the supply chain where the real “gold” can be found.

However, the complexity of business processes must be acknowledged. Business processes can vary significantly in terms of levels (strategic or operational process) and scopes (activities involved in a process). SCM itself, in fact, can be considered a business process. For example, Ross, Venkataramanan, and Ernstberger (1998) viewed supply chain process as the actual physical business functions, institutions, and operations that characterize the way a particular supply chain moves goods and services to market through the supply chain pipeline. Alternately, a small set of activities employed to handle a customer’s defective product complaint is also a business process. Unless all major business processes and relevant sub-processes can be identified and understood explicitly, process management can be difficult to implement (cf. Lambert 2004). The process approach toward supply chain integration is best manifested in the Supply Chain Council’s popular Supply Chain Operations Reference-model (SCOR) that suggests that business should be managed based on key processes – plan, source, make, deliver, and return (see [www.supply-chain.org](http://www.supply-chain.org)). Similarly, the Global Supply Chain Forum also proposed that it is necessary to identify the relevant business processes and manage them effectively (Croxtton et al. 2001; Lambert, 2004). The eight supply chain processes suggested include:

- 1) Customer relationship management
- 2) Customer service management
- 3) Demand management
- 4) Order fulfillment

- 5) Manufacturing flow management
- 6) Supplier relationship management
- 7) Product development and customization
- 8) Returns management

Without a process view, integration may lose its focus. Recognizing and examining this aspect of integration is one problem with the extant literature. For example, some studies emphasized the importance of information integration (e.g. Bagchi and Skioett-Larsen 2003; Saaksjarvi and Talvinen 1993). However, companies do not integrate information only for the purpose of creating smooth information flow; they try to utilize the information more effectively to support the management of respective business processes. Similarly, companies integrate functional departments (e.g. marketing and logistics) in order to manage relevant processes across areas more effectively; and companies integrate with external partners (e.g. backward with suppliers and forward with customers) for the purpose of better administering the business processes along the supply chain.

Based on the above discussion about the internal-external perspective and the process view, it is suggested that research on integration should focus on the *internal and external process integration*. Consequently, this is the locus of the current study.

### **Conceptualizing Supply Chain Process Integration**

Following review and synthesis of existing literature, a qualitative study was conducted in both China and the United States to collect crucial inputs from the managers. China has emerged as one of the key manufacturing hubs in recent years; many Chinese firms have significantly improved their supply chain management practices and have become an integral part of global supply chains. Thus, China provides a viable context to develop and test the proposed conceptualization. The objectives were

to explore the meaning of integration for managers and to identify key dimensions of internal and external process integration. Close qualitative field investigation with study participants helps researchers better understand the core phenomenon and develop solid foundation for future theoretical research (Glaser 2001; Strauss 1987; Strauss and Corbin 1990).

Ten senior executives from leading Chinese companies in various industries were interviewed via telephone calls in a discovery-oriented and open-ended format. They were asked to discuss their understanding of integration in-depth. Notes were taken during the conversation and the transcripts were later analyzed. In the U.S., transcripts of sixty logistics executives' open-end responses to a supply chain integration related study were carefully reviewed. Since all of the executives hold supply chain related key positions within their respective companies (all at the vice president and director level), they are assumed to have sufficient knowledge about their companies' supply chain management practices. Efforts were made to identify common concepts within each transcript and across transcripts. Specifically, each transcript was read several times in its entirety and analyzed at the sentence and paragraph level. Special attention was paid to ensure construct equivalency between Chinese and English transcripts. Through multiple iterations and comparison of concepts, a smaller group of integration related concepts was revealed.

While the results demonstrated different levels of supply chain integration in Chinese companies and the U.S. companies, analysis of the data from two sources yielded very similar results and common themes on the core meaning of integration. Summarizing the inputs from the Chinese and U.S. managers, it is proposed that both



internal and external process integration has two key elements: connectivity and simplification. Connectivity refers to smooth linkages between different business processes within and across firms; simplification is about eliminating the unnecessary parts or steps of connected processes.

For example, a Vice President of one leading Chinese home appliance manufacturer noted the importance of connecting internal processes:

“The first thing I can think of when talking about integration is connection. I want my sales department to link their marketing activities with the production scheduling seamlessly, and at the same time I want my procurement department to facilitate the production 100%.”

A U.S. manager commented on connecting the processes across firms:

“Our supplier changed their process and we changed our requirements to integrate the backhaul (across both companies).”

Reducing or eliminating unnecessary processes also emerged as a key component of supply chain integration. For instance, one Chinese executive from a large medical equipment manufacturer emphasized the importance of simplification:

“With integration, our company is trying to make things simple, both for our customers and for our own employees. There were too many unnecessary steps in the past.”

His comment is echoed by many other managers. For example, a U.S. respondent also explicitly stated that,

“Collaboration is about information sharing and partnership, but beyond that we integrate our processes (with customers). It’s all about ‘simple’. The goal is to eliminate the waste in the value chain.”

Both key components of integration – connectivity and simplification – are highlighted in existing definitions of integration. First, researchers have acknowledged the importance of seamlessly connecting related business processes to meeting the

overall organizational objectives (Porter 1980, 1985). Stank, Keller, and Closs (2001) defined internal integration as the competency of linking internally performed work into a seamless process to support customer requirements and supplier integration as the competency of linking externally performed work into a seamless congruency with internal work processes. According to Rodrigues, Stank, and Lynch (2004), internal integration is achieved by linking operations into a seamless, synchronized operational flow. Similarly, Germain, Dröge, and Daugherty (1994) considered integration as lateral links between subunits. Lambert, García-Dastugue, and Croxton (2005) also suggested that intra-company and inter-company connectedness are the key elements of SCM. The previously quoted comment made by the Chinese executive is a perfect example – it is necessary to connect the selling process with manufacturing and procurement processes in order to achieve integration. Although it is important to identify and connect related business processes, not all business processes should be directly connected. For example, in order to achieve manufacturing flexibility, the production process should be connected with the processes of customer relationship management and demand management, but not with the returns management process (Lambert 2004).

Second, simplifying the business processes by removing duplications is equally important. Connecting relevant business processes is not enough; efforts should also be taken to identify and eliminate excessive elements within the processes, including the seven classic wastes of Shigeo Shingo: overproduction, waiting, transportation, unnecessary processing steps, stocks, motion, and defects (Hall, 1987; Frohlich and Westbrook, 2001). In other words, the processes need to be re-engineered to improve efficiency and effectiveness. The importance of simplification is supported by the

studies conducted by Bowersox, Closs, and Stank (1999) and Germain, Dröge, and Daugherty (1994). Simplification includes designing effective and efficient routines by establishing and adhering to common operational policies and procedures (cf. Bowersox, Closs, and Stank 1999). The successful process integration implemented by Bose Corporation also supports this rationale – one key step is focusing on creating common policies, guidelines, and methods for expanding improvement efforts within and between functional areas, in order to achieve simplified processes (Segars, Harkness, and Kettinger 2001). Joint planning and decision-making, instead of having these activities carried out in different processes, is another type of simplification (cf. Barratt and Oliveira 2001; Song and Xie 2000).

This approach to the conceptualization of process integration does not conflict with existing literature. Instead, it provides a better way to understand the essence of integration and identifies objectives on which managers should focus. Various dimensions and types of integration identified by other researchers represent the procedures that create and facilitate these two key components of process integration. For example, the concept of information integration is about increasing visibility along the supply chain and enables connectivity between processes; the concept of organizational integration refers to restructuring the arrangement within and across firms to simplify the processes. At the same time, the behavioral dimensions suggested by other researchers, such as collaboration, interaction, and consultation (e.g. Ellinger, Daugherty, and Keller 2000, Kahn and Menzter 1998), are also necessary to implement process integration. Since it is argued that a process view is critical to integration, a new definition of process integration is proposed based on the above discussion.

*Process integration* refers to the management of various sets of activities that aims at seamlessly linking relevant business processes within and across firms and eliminating duplicate or unnecessary parts of the processes for the purpose of building a better-functioning supply chain.

Based on this conceptualization, *internal process integration* refers to the management of restructuring activities that aims at seamlessly linking relevant business processes and reducing redundant processes within a firm. Thus, two key dimensions of internal process integration are *internal process connectivity* and *internal process simplification*. *External process integration* is a different construct and is defined similarly using the same two components, but in an external context. Despite the similarity in the definitions, significant distinctions exist between internal and external process integration. These differences will be manifested in the operationalization of the concepts. External process integration also has two key elements: *external process connectivity* and *external process simplification*. Although distinct constructs, internal and external process integration are related to each other. As Stevens (1989) suggested, in order to successfully integrate with external partners, a firm needs to achieve a high level of internal integration first. On the other side, external process integration provides an overall visibility, direction, and pattern for understanding the influences of activities within and between firms. For instance, necessary intelligence collected from external partners, such as information on order patterns, planned product promotions, and valuable service feedbacks, enables a firm to better integrate its internal processes (Stank, Keller, and Daugherty 2001). The proposed conceptualization of internal and external supply chain process integration is thus shown in Figure 1.

It should also be realized that process integration is not a dichotomous concept (integrated or not). Process integration implementation is a gradual procedure for a

company or a supply chain. Continuous efforts are necessary to adjust the integration to the changing environment. In fact, many researchers and industry studies have found that true integration is still rare (e.g. Fawcett and Magnan 2002). Thus, it is proposed that the construct of process integration is a continuum, similar to the stage typology suggested by Stevens (1989), and should be measured along two key embedded dimensions: connectivity and simplification. The detailed operationalizations of internal and external process integration are presented in the next section.

**FIGURE 1.  
PROPOSED CONCEPTUALIZATION**

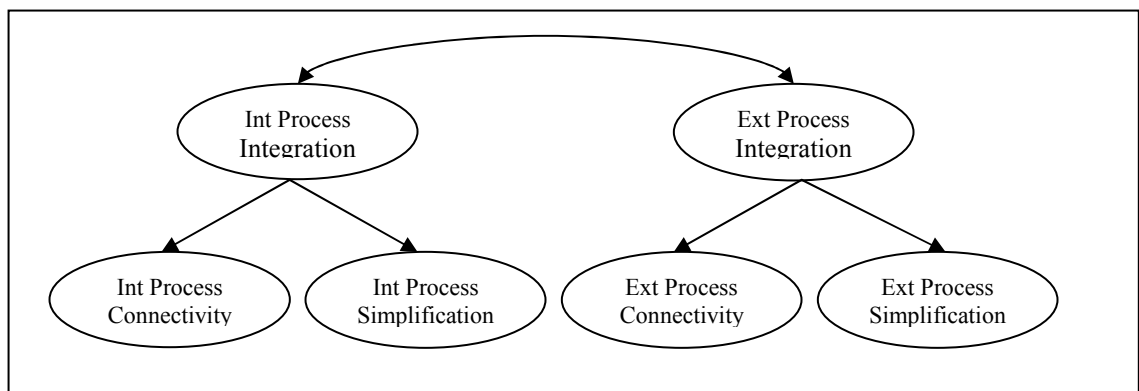

**OPERATIONALIZING SUPPLY CHAIN PROCESS INTEGRATION**

In order to validate the proposed definition of supply chain process integration and develop a set of reliable and valid scale items to measure integration related constructs, a survey was conducted in China.

**Data Collection**

A survey research design was used to collect data for scale development. Dillman’s (2000) total design approach was followed to develop and administer the questionnaire. All variables of interest were estimated through respondents’ perceptual evaluation on a seven-point Likert-type scale, which was anchored by 1 (Strongly

Disagree) and 7 (Strongly Agree). The original measurement items were first developed in English and the questionnaire was conducted in Chinese. Five qualified Chinese native experts (all hold either a Ph.D. in business or MBA from the U.S.) were asked to translate the final copy of the questionnaire from English into Chinese. Their translation was synthesized into one copy. Then, the Chinese version was back translated into English and compared with the original English copy to ensure the equivalency of both versions.

The electronics manufacturing industry was selected because it evidences some of the best management practices in China and is the closest to their international counterparts in terms of development level. Focusing on one industry also helps eliminate industry specific factors and generate more valid results. In order to ensure that respondents have sufficient knowledge and experience to answer questions related to supply chain process integration, executives in relevant areas were targeted (including SCM/logistics, marketing, operations, and manufacturing) within their companies. It was assumed that these managers were knowledgeable about their companies' SCM practices and able to answer the questions of interest.

In order to improve the efficiency of data collection, the questionnaire was available in two formats: traditional mail survey and online survey through the website of [www.zoomerang.com](http://www.zoomerang.com). An initial list was randomly generated from several electronics industry directories. Potential respondents were first contacted with a telephone call, and contact information was requested to ensure the proper delivery of hardcopy questionnaire and/or web link to the online survey. Questionnaires were sent to a total of 900 potential respondents. A follow-up phone call was made every two weeks to each

potential respondent; up to three follow-up phone calls were made to each person. A total of 362 completed surveys were returned during the three-month period. Of these, some surveys were eliminated for the following reasons: (1) too much missing data; (2) the company was not in the electronics manufacturing industry; and (3) the respondent did not identify his/her position or hold a qualifying position within the company. Furthermore, all respondents were asked to indicate the level of their agreement on a question at the end of each questionnaire: "I had enough information to answer all the questions (1 = Strongly Disagree, 4 = Neutral, and 7 = Strongly Agree)." The responses scoring 4 or lower on this question were also eliminated. This yielded 304 usable responses, representing a 33.8% response rate (i.e., 304/900). Traditional mail surveys accounted for 141 responses; 163 were completed online. All items were submitted to *t*-tests to compare mail and online responses. The results showed no significant difference. It is thus believed that these 304 usable responses can be analyzed as a single data set. Company information shown in Appendix B indicates that all responding firms are in the expected industry and have reasonable size. Personal information on respondents shown in Appendix C demonstrates their qualifications for the current study.

To further ensure the validity of the responses, all respondents were asked to identify two major customers, to whom a corresponding survey could be sent to evaluate the focal company's external process integration. However, due to the fact that most Chinese companies perceive their key accounts information as proprietary, only 41 companies provided complete contact information for their major customers. Corresponding surveys were sent to these 41 customer companies to evaluate their suppliers' external process integration practices. Thirty completed surveys were

received, representing a 73.2% response rate. A *t*-test of the paired sample resulted in no significant differences, indicating the responses from the focal companies were objective and valid.

Potential non-response bias was examined utilizing two approaches: (1) comparing early and late responses for all items through ANOVA (Armstrong and Overton 1977); and (2) comparing all respondents with 30 randomly contacted non-respondents on ten non-demographic questions in the questionnaire through ANOVA (Lohr 1999; Mentzer and Flint 1997). Both methods showed no statistically significant differences. Thus, non-response bias was not considered to be a threat for this study.

### **Measurement Items Development**

The development of measurement items followed the process several authors recommended (Churchill 1979; Gerbing and Anderson 1988; Min and Menzter 2004). First, a large pool of potential items was generated from the literature and interviews with industry experts. Because both internal process integration and external process integration are latent variables that cannot be observed directly, a fundamental principle was followed – each construct should be measured by at least two, and preferably more, different items (Churchill 1979). A subset of items was selected from the item pool based on the criteria of uniqueness and the ability to convey different meanings to respondents through content and face validity tests (Churchill 1979).

Second, selected items were submitted to the review of six academic experts in the U.S. They were all qualified researchers in the field of SCM. They were asked to review the survey for domain representativeness, item specificity, clarity of construct,



and readability (i.e. content and face validity) (Dillman 2000). Based on their inputs, some of the measurement items were eliminated or reworded, and others were added.

Third, the resulting items were reviewed by fifteen industry experts. They were asked to complete a survey and indicate any ambiguity or other difficulties they experienced in responding to the items. Their feedbacks and suggestions were used to modify the questionnaire.

Finally, item purification was done with statistical analysis and qualitative assessment. Structural Equation Modeling (SEM) (with AMOS 5.0) was used as the main statistical analysis tool to purify and validate the measurement items. SEM is a powerful technique that combines the measurement model (confirmatory factor analysis) and the structural model (path analysis) into a simultaneous statistical test (Aaker and Bagozzi 1979; Gerbing and Anderson 1988). Prior to statistical analysis, the approach suggested by Mentzer, Flint, and Kent (1999) was followed to conduct a basic analysis of the collected data, including examination of incorrect coding, item normality, means, standard deviations, and outliers, yielding acceptable results.

The primary measurement item purification was conducted with multiple iterations of confirmatory factor analysis (CFA) through maximum likelihood estimation (MLE). Indicators such as offending estimates, squared multiple correlations, standardized residual covariances, and modification indices were examined to determine whether modification was needed. Theoretical assessment or qualitative review was made before final deletion of any measurement items. Offending estimates such as negative error terms, standardized coefficients exceeding or very close to 1.0, and very large standard errors associated with estimated coefficients were examined (Hair et al.

1998). Small squared multiple correlations value demonstrates that the portion of a variable's variance explained by its predictors is minimal, suggesting consideration of deletion (Jöreskog and Sörbom 1989; Min and Menzter 2004). Significant standardized residuals ( $> |2.58|$ ) indicate a substantial prediction error, because standardized residuals are the differences between the observed and estimated covariance matrix (Hair et al. 1998). Jöreskog and Sörbom (1988) suggested that if the value of the modification index (MI) of a coefficient value is equal to or greater than 3.84, chi-square can be reduced significantly statistically with the estimation of coefficient. A large MI value indicates the presence of factor cross-loading (Byrne 2001), thus MIs with value equal to or greater than ten were closely monitored (Fassinger 1987). During the measurement purification process, hypothesized model adequacy was also assessed with overall model fit indices such as chi-square/degree of freedom (CMIN/DF), Goodness of Fit (GFI), Normed Fit Index (NFI), Incremental Fit Index (IFI), Comparative Fit Index (CFI), and Root Mean Square of Approximation (RMSEA). In addition, construct reliability and validity were also constantly examined with rigorous tests throughout the process. The next section will provide more details on these indices and tests.

### **Final Measurement Model**

After the iterative process of item refinement and purification, a large pool of items was reduced to the final set of items to measure the two proposed integration related constructs – *internal process integration* and *external process integration*. These are two higher-order constructs and each has two dimensions (first-order constructs) – *connectivity* and *simplification*. In the final measurement model, five items were used to measure each of the first-order constructs (see Table 1 and Figure 2).

**TABLE 1**  
**CONSTRUCTS AND MEASUREMENT ITEMS**

<b>Constructs and Measurement Items</b>	<b>Mean</b>	<b>Std. Dev.</b>
<b><i>Internal Process Integration</i></b>		
<i>- Internal Process Connectivity</i>		
Our firm		
IC1. ...designates people with particular skills to coordinate various internal processes.	4.79	1.51
IC2. ...develops a common goal to align the efforts of all processes, in addition to setting specific objectives for each process.	5.14	1.47
IC3. ...ensures compatibility among all relevant internal processes.	5.07	1.45
IC4. ...uses common standards for all internal processes so that processes can be linked smoothly.	4.91	1.43
IC5. ...communicates information in a timely manner about specific internal processes to facilitate other related processes.	5.18	1.44
<i>- Internal Process Simplification</i>		
Our firm		
IS1. ...reduces operational complexity.	4.92	1.40
IS2. ...simplifies product design to reduce process complexity without sacrificing product functionality.	4.98	1.35
IS3. ...regularly evaluates whether there are redundant activities within internal processes.	4.82	1.35
IS4. ...reduces unnecessary steps within internal processes.	4.74	1.50
IS5. ...reduces the need for employees in different areas to perform identical job tasks.	4.80	1.55
<b><i>External Process Integration</i></b>		
<i>- External Process Connectivity</i>		
Our firm along with our major partners		
EC1. ...discuss processes across our business operations when we conduct strategic planning.	4.68	1.49
EC2. ...try to develop common goals to align process efforts.	4.81	1.49
EC3. ...ensure compatibility between related processes of different firms.	4.70	1.54
EC4. ...use common standards to link processes smoothly across firms.	4.69	1.45
EC5. ...share information in a timely manner to facilitate cross-organizational processes.	5.01	1.49
<i>- External Process Simplification</i>		
Our firm along with our major partners		
ES1. ...work together to redesign work routines and processes for the purpose of simplicity.	4.70	1.48
ES2. ...work together to reduce operational complexity.	4.68	1.50
ES3. ...focus on reducing channel complexity.	4.88	1.44
ES4. ...regularly evaluate whether there are redundant activities within various processes across firms.	4.58	1.46
ES5. ...reduce/eliminate source inspection, receiving inspection, and count verification through our firm's supplier certification program.	4.71	1.55

**FIGURE 2**  
**PROPOSED MEASUREMENT MODEL**

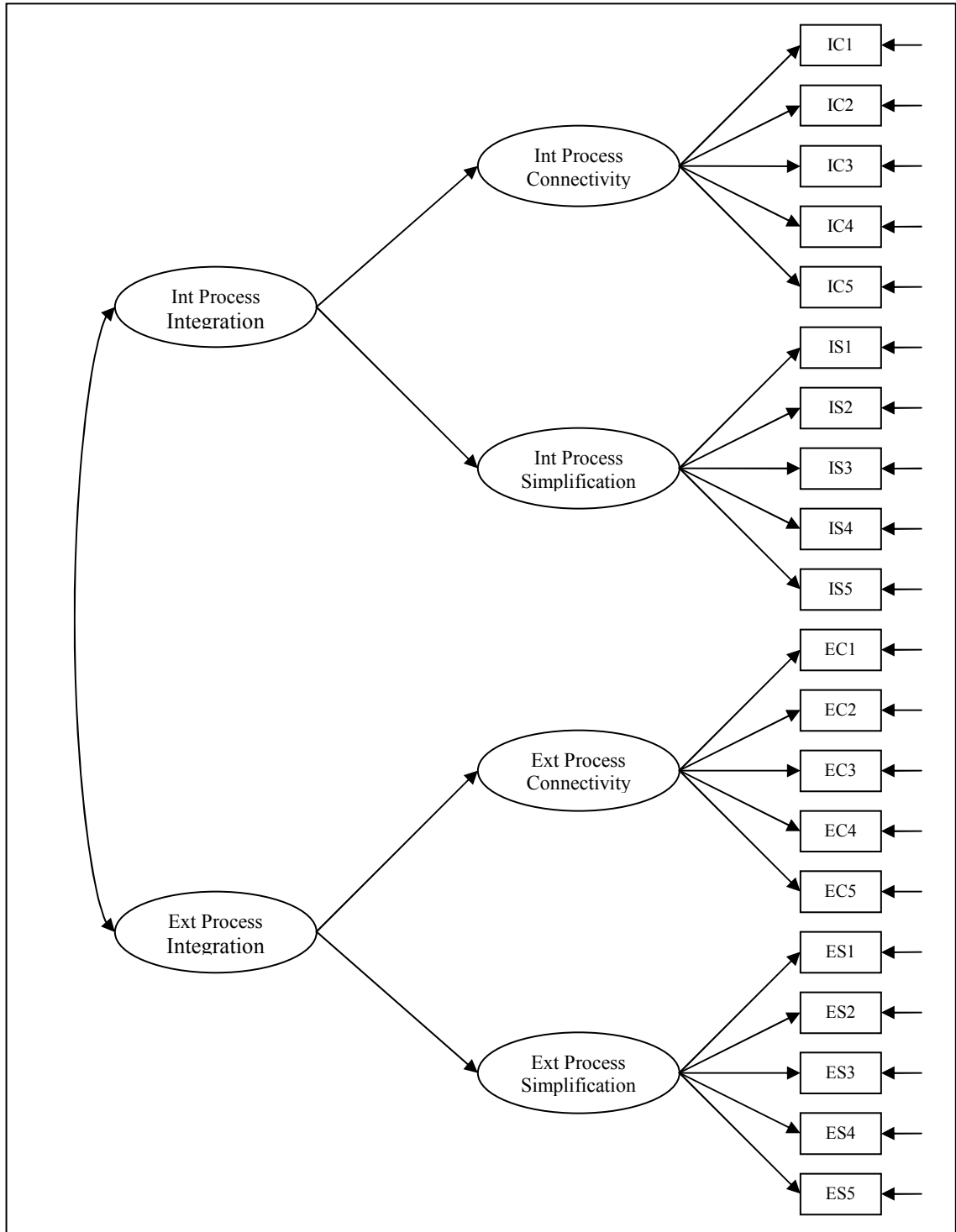

A CFA test of the final measurement model using AMOS 5.0 yielded superior model fit indices. CMIN/DF was developed to address the limitations of chi-square index (Byrne 2001), and the suggested ratio is within the range from 3 to 1 (Carmines and McIver 1981). The CMIN/DF value of 1.714 demonstrated acceptable fit between the hypothesized model and the sample data. GFI represents the degree to which the actual or observed covariance matrix is predicted by the estimated model, and the value of 0.917 is above suggested 0.9, representing a strong fit (Bentler and Bonett 1980; Hu and Bentler 1995). The NFI value of 0.926 is also above the suggested 0.9. IFI was developed by Bollen (1989) to address the issues of parsimony and sample size by taking degrees of freedom into account. The value of 0.968 indicates a good-fitting model. CFI is another comparative fit index. It has been argued that CFI is the single most important index since it accounts for sample size – a common bias in index calculations (Bentler 1990; Byrne 2001). The CFI value of 0.968 in the current model shows superior fit. RMSEA represents the discrepancy per degree of freedom measured in terms of the population (Hair et al. 1998). RMSEA value in the current model is 0.049, well below the suggested 0.08, thus indicating close model fit (Browne and Cudeck 1993).

After confirming the overall fit between the hypothesized model and the sample data, the measurement model's unidimensionality and validity were examined with the estimates of regression weights, standard errors, and critical ratios (CR) (Table 2). Critical ratios of regression weights of the items were significant ( $>1.96$ ) for all first and second order factors. Unidimensionality for each construct was, therefore, validated (Gerbing and Anderson 1988). Discriminant validity of the first-order constructs was

tested with the approach suggested by Fornell and Larcker (1981) – comparing the average variance extracted (AVE) of each construct with the shared variances between each of the constructs. As shown in the Table 3, all average variances extracted were in excess of the shared variances between constructs for each of the two-factor models, demonstrating discriminant validity.

**TABLE 2**  
**MEASUREMENT MODEL RESULTS**

<b>Path</b>	<b>Standardized Weights</b>	<b>Critical Ratio</b>	<b>p-value</b>
Int Process Integration ↔ Ext Process Integration	0.860	17.670	< 0.001
Int Process Connectivity ← Int Process Integration	0.660	9.242	< 0.001
Int Process Simplification ← Int Process Integration	0.790	10.311	< 0.001
Ext Process Connectivity ← Ext Process Integration	0.865	13.765	< 0.001
Ext Process Simplification ← Ext Process Integration	0.898	14.206	< 0.001
IC1 ← Int Process Connectivity	0.759	(fixed)	
IC2 ← Int Process Connectivity	0.805	14.207	< 0.001
IC3 ← Int Process Connectivity	0.841	14.669	< 0.001
IC4 ← Int Process Connectivity	0.734	12.774	< 0.001
IC5 ← Int Process Connectivity	0.769	13.547	< 0.001
IS1 ← Int Process Simplification	0.755	(fixed)	
IS2 ← Int Process Simplification	0.628	10.474	< 0.001
IS3 ← Int Process Simplification	0.665	10.796	< 0.001
IS4 ← Int Process Simplification	0.707	11.621	< 0.001
IS5 ← Int Process Simplification	0.750	12.171	< 0.001
EC1 ← Ext Process Connectivity	0.841	(fixed)	
EC2 ← Ext Process Connectivity	0.854	18.721	< 0.001
EC3 ← Ext Process Connectivity	0.858	18.600	< 0.001
EC4 ← Ext Process Connectivity	0.781	15.911	< 0.001
EC5 ← Ext Process Connectivity	0.791	16.133	< 0.001
ES1 ← Ext Process Simplification	0.847	(fixed)	
ES2 ← Ext Process Simplification	0.873	19.028	< 0.001
ES3 ← Ext Process Simplification	0.810	16.947	< 0.001
ES4 ← Ext Process Simplification	0.766	15.519	< 0.001
ES5 ← Ext Process Simplification	0.629	11.937	< 0.001

Fit statistics:

Chi-square = 282.843 ( $df = 165$ ,  $p < .001$ ), Chi-square/ $df$  (CMIN/DF) = 1.714  
GFI = 0.917, NFI = 0.926, IFI = 0.968, CFI = 0.968, RMSEA = 0.049

**TABLE 3**  
**TESTS FOR CONSTRUCT DISCRIMINANT VALIDITY**

	Int Process Connectivity	Int Process Simplification	Ext Process Connectivity	Ext Process Simplification
Avg. Variance Extracted	0.612	0.494	0.682	0.623
Shared Variance				
Int Process Connectivity	-			
Int Process Simplification	0.271	-		
Ext Process Connectivity	0.240	0.345	-	
Ext Process Simplification	0.259	0.371	0.604	-

Widaman's (1985) three-comparison-model approach was also used to test the convergent and discriminant validity (see Figure 3): Model 0 with each individual measurement item as unique factor in a construct; Model 1 with individual items loaded on one unique first order factor; and Model 2 with individual items loaded on appropriate first order factors that, in turn, are loaded on a second order factor. Significant chi-square statistics in the comparison of Model 0 and Model 1 suggested convergent validity; and the comparison of Model 1 and 2 provide evidence of discriminant validity.

The constructs' internal consistency reliability was then tested in two ways; results are shown in Table 4. First, Cronbach's alpha based on the average inter-item correlations was calculated for each construct. The results are all well above the suggested 0.7 (Nunnally 1978), demonstrating superior level of reliability. Second, construct reliability value was also calculated with the approach suggested by Fornell and Larcker (1981), which does not assume all loadings are the same. Again, all values are well above the suggested 0.7 (Hair et al. 1998). In sum, the proposed constructs demonstrated a high level of internal consistency reliability.

**FIGURE 3**  
**WIDAMAN'S THREE-MODEL-COMPARISON**

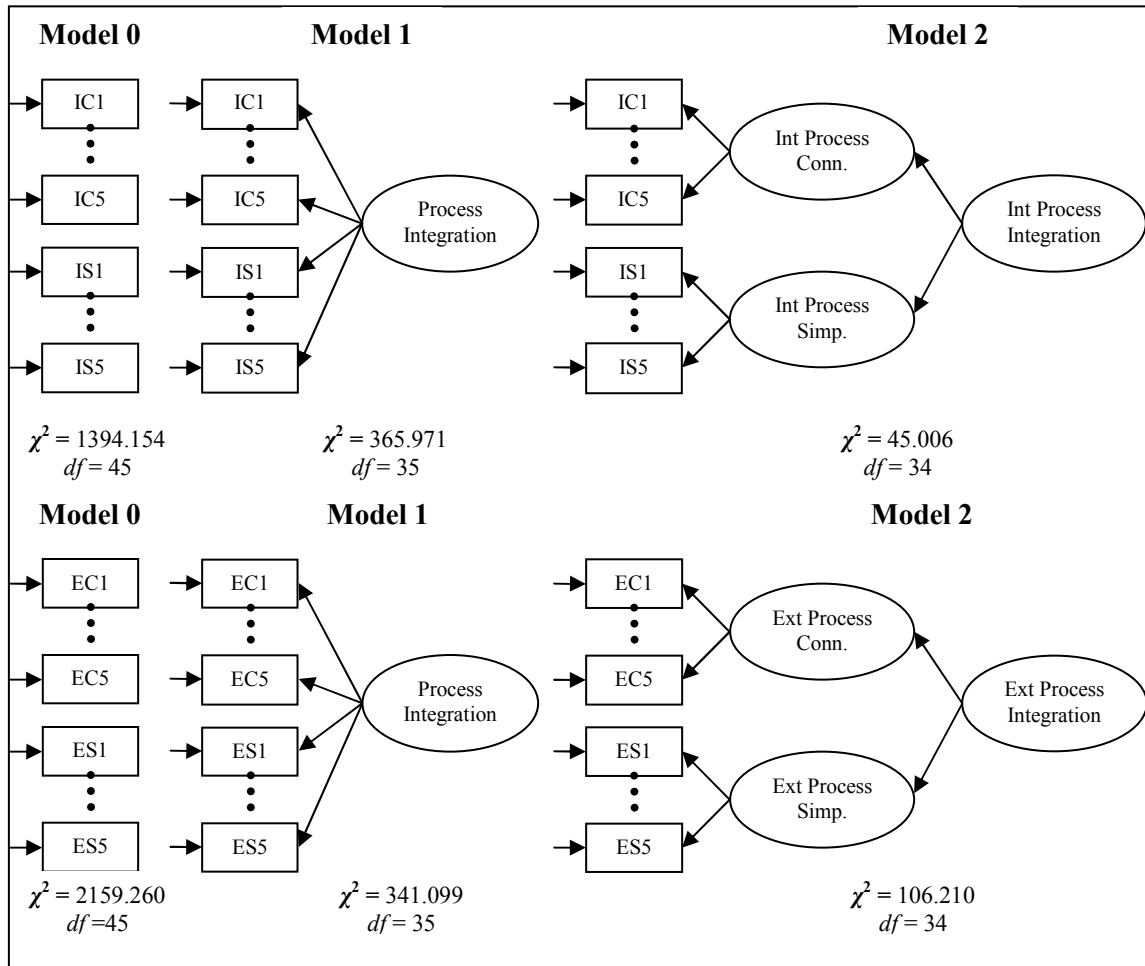

**TABLE 4**  
**CONSTRUCTS' RELIABILITY TESTS**

	<b>Cronbach's Alpha</b>	<b>Construct Reliability</b>
Int Process Connectivity	0.887	0.867
Int Process Simplification	0.828	0.784
Ext Process Connectivity	0.914	0.892
Ext Process Simplification	0.886	0.895

As the measurement model was validated with SEM, estimation of a structural model including the constructs of internal process integration and external process integration was necessary to test their nomological validity, which is the extent to which



measures of different but related constructs correlate to each other in theoretically predicted ways (Garver and Mentzer 1999; Min and Mentzer 2004). Previous studies have supported the positive impacts of external integration on firm performance (e.g. Bagchi and Skjoett-Larsen 2002; Larson 1994; Maloni and Benton 2000). Additionally, it is generally believed that internal integration is the foundation of external integration (Stevens 1989). Therefore, a causal structural model is proposed as shown in Figure 5.

**FIGURE 5  
PROPOSED STRUCTURAL MODEL**

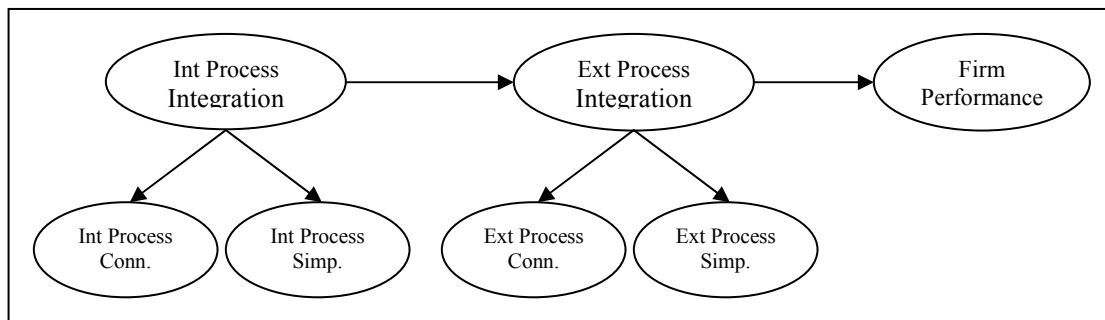

The performance scale includes five items commonly used in other studies and measures a firm’s performance relative to its major competitors in areas of sales volume, profit, return on investment (ROI), customer satisfaction, and overall firm competitiveness. This is a seven-point Likert-type scale anchored by 1 (Much Worse) and 7 (Much Better), and its reliability was supported with a Cronbach’s alpha value of 0.867. Before testing the structural model, all constructs’ validity was tested and confirmed with the approach described earlier.

The structural model was tested with SEM and resulted in satisfactory results (CMIN/DF = 1.722, NFI = 0.904, IFI = 0.958, CFI = 0.957, RMSEA = 0.049). Also, the positive links (i.e. internal process integration → external process integration, external process integration → firm performance) were supported with critical ratios of 7.340 and

8.632 respectively (both are significant at 0.001 level). Standardized regression weights and critical ratios in this model are shown in Table 5. Thus, it can be concluded that nomological validity of the constructs internal process integration and external process integration was supported.

**TABLE 5**  
**STRUCTURAL MODEL RESULTS**

<b>Path</b>	<b>Standardized Weights</b>	<b>Critical Ratio</b>	<b>p-value</b>
Ext Process Integration ← Int Process Integration	0.846	7.340	< 0.001
Firm Performance ← Ext Process Integration	0.690	8.632	< 0.001
Int Process Connectivity ← Int Process Integration	0.667	(fixed)	
Int Process Simplification ← Int Process Integration	0.781	7.467	< 0.001
Ext Process Connectivity ← Ext Process Integration	0.890	(fixed)	
Ext Process Simplification ← Ext Process Integration	0.881	11.978	< 0.001
IC1 ← Int Process Connectivity	0.758	(fixed)	
IC2 ← Int Process Connectivity	0.805	14.182	< 0.001
IC3 ← Int Process Connectivity	0.842	14.657	< 0.001
IC4 ← Int Process Connectivity	0.735	12.771	< 0.001
IC5 ← Int Process Connectivity	0.769	13.524	< 0.001
IS1 ← Int Process Simplification	0.755	(fixed)	
IS2 ← Int Process Simplification	0.624	10.413	< 0.001
IS3 ← Int Process Simplification	0.665	10.786	< 0.001
IS4 ← Int Process Simplification	0.710	11.627	< 0.001
IS5 ← Int Process Simplification	0.751	12.153	< 0.001
EC1 ← Ext Process Connectivity	0.842	(fixed)	
EC2 ← Ext Process Connectivity	0.851	18.648	< 0.001
EC3 ← Ext Process Connectivity	0.858	18.663	< 0.001
EC4 ← Ext Process Connectivity	0.785	16.058	< 0.001
EC5 ← Ext Process Connectivity	0.791	16.184	< 0.001
ES1 ← Ext Process Simplification	0.848	(fixed)	
ES2 ← Ext Process Simplification	0.869	18.991	< 0.001
ES3 ← Ext Process Simplification	0.809	16.953	< 0.001
ES4 ← Ext Process Simplification	0.770	15.662	< 0.001
ES5 ← Ext Process Simplification	0.629	11.959	< 0.001
PF1 ← Firm Performance	0.636	(fixed)	
PF2 ← Firm Performance	0.808	11.368	< 0.001
PF3 ← Firm Performance	0.823	11.378	< 0.001
PF4 ← Firm Performance	0.715	10.329	< 0.001
PF5 ← Firm Performance	0.798	11.401	< 0.001

Fit statistics:

Chi-square = 463.119 ( $df = 269$ ,  $p < .001$ ), Chi-square/ $df$  (CMIN/DF) = 1.722  
NFI = 0.904, IFI = 0.958, CFI = 0.957, RMSEA = 0.049

## CONCLUSION AND IMPLICATIONS

The goal of the current study was to develop a conceptualization of supply chain process integration that can be generally applied. The extensive literature review and qualitative study yielded two distinct but related integration related constructs – *internal process integration* and *external process integration*, each with two dimensions – *connectivity* and *simplification*. An internal-external perspective and a process view of integration are emphasized in the proposal. In addition, new measures were developed for these constructs. Using the collected data, the proposed model passed rigorous tests, supporting unidimensionality, construct validity (include convergent and discriminant validity), internal consistency reliability, and nomological validity.

The findings of this study have important research and managerial implications. Different authors have conceptualized the notion of supply chain integration differently. Compared with previous conceptualizations, the proposed conceptualization is more explicit and relevant in that it calls attention to the idea of simultaneously managing activities and processes efficiently within and across firms. Furthermore, it sharpens the focus on particular areas to better understand the interaction of processes.

When the concept of integration is vaguely defined and measured with a few broad items, the nuances and complexity involved with integration cannot be captured and understood. And, when the construct is defined with too many dimensions or specifics, the research may lose its focus. However, the proposed dimensions – *connectivity* and *simplification* – can help researchers to grasp the essence of supply chain integration in various scenarios.

Since the data used in the current study were collected in China, future studies should validate the proposed conceptualization in the U.S. or other countries. Also, the current survey study was conducted in a single industry – the electronics industry. Future research in other industries will also be necessary to test the generalizability of this conceptualization.

While a simple causal model (with performance as the outcome) based on previous research was tested to examine the nomological validity of the constructs, future research is warranted to explore the proposed constructs' relationships with other constructs. As Pagell (2004) pointed out, research on integration's drivers or antecedents is much needed.

For managers involved in SCM, this study offers a clear conceptualization of supply chain integration to help them better plan, organize, and implement supply chain integration. The results show that managers should be ready to face different challenges from internal and external process integration. As indicated with the different measurement items, managers should take different actions and emphasize different areas in internal and external process integration. Furthermore, their focus needs to be placed on connecting and simplifying processes during the integration implementation. However, it is necessary to realize that the scales are not intended to provide an exhaustive activity list for implementing integration. Rather, these scale items offer a good starting point to identify the important areas that need more attention.

In conclusion, this study offers a new venue to study supply chain integration. As for any newly developed conceptualization, the robustness of the new definition and operationalization of supply chain process integration can stand improvement. Thus,

future research is called for to continuously refine and strengthen the findings of this study.

## REFERENCES

- Aaker, David A. and Richard P. Bagozzi (1979), "Unobservable Variables in Structural Equation Models with an Application in Industrial Selling," *Journal of Marketing Research*, Vol. 16, No. 2, pp. 147-158.
- Armstrong, J. Scott and Terry S. Overton (1977), "Estimating Nonresponse Bias in Mail Surveys," *Journal of Marketing Research*, Vol. 14, No. 3, pp. 396-402.
- Ayers, Doug, Robert Dahlstrom, and Steven J. Skinner (1997), "An Exploratory Investigation of Organizational Antecedents of New Product Success," *Journal of Marketing Research*, Vol. 34, No. 1, pp. 107-116.
- Bagchi, Prabhir K. and Tage Skjoett-Larsen (2003), "Integration of Information Technology and Organizations in a Supply Chain," *International Journal of Logistics Management*, Vol. 14, No. 1, pp. 89-108.
- Barratt, Mark and Alexander Oliveira (2001), "Exploring the Experiences of Collaborative Planning Initiatives," *International Journal of Physical Distribution & Logistics Management*, Vol. 31, No. 4, pp.266-289.
- Bentler, Peter M. (1990), "Comparative Fit Indexes in Structural Models," *Psychological Bulletin*, Vol. 107, No. 2, pp. 238-246.
- Bentler, Peter M. and Douglas G. Bonett (1980), "Significance Tests and Goodness of Fit in the Analysis of Covariance Structures," *Psychological Bulletin*, Vol. 88, No. 3, pp. 588-606.
- Bollen, Kenneth A. (1989), "A New Incremental Fit Index for General Structural Equation Models," *Sociological Methods and Research*, Vol. 17, pp. 303-316.
- Bowersox, Donald J., David J. Closs, and Theodore P. Stank (1999), *21<sup>st</sup> Century Logistics: Making Supply Chain Integration A Reality*, Oak Brook, IL: Council of Logistics Management.
- Browne, Michael W. and Robert Cudeck (1993), "Alternative Ways of Assessing Model Fit," in *Testing Structural Equation Models*, Kenneth A. Bollen and J. Scott Long, eds., Newberry Park, CA: Sage Publication, pp. 136-162.
- Byrne, Barbara M. (2001), *Structural Equation Modeling with AMOS: Basic Concepts, Applications, and Programming*, Mahwah, NJ: Lawrence Erlbaum Associates Publishers.
- Carmines, Edward G. and John P. McIver (1981), "Analyzing Models with Unobserved Variables: Analysis of Covariance Structures," in *Social Measurement: Current Issues*,

George W. Bohrnstedt and Edgar F. Borgatta, Eds., Beverly Hills, CA: Sage Publications.

Churchill, Gilbert A. (1979), "A Paradigm for Developing Better Measures of Marketing," *Journal of Marketing Research*, Vol. 16, No. 1, pp. 64-73.

Coase, Ronald H. (1937), "The Nature of the Firm," *Economica*, Vol. 4, No. 16, pp. 386-405

Cooper, Martha C., Lisa M. Ellram, John T. Gardner, and Albert M. Hanks (1997), "Meshing Multiple Alliances," *Journal of Business Logistics*, Vol. 18, No. 1, pp. 67-89.

Cooper, Martha C., Douglas M. Lambert and Janus D. Pagh (1997), "Supply Chain Management: More Than a New Name for Logistics," *International Journal of Logistics Management*, Vol. 8, No. 1, pp. 1-14.

Croxton, Keely L., Sebastián J. García-Dastugue, Douglas M. Lambert, and Dale S. Rogers (2001), "The Supply Chain Management Processes," *International Journal of Logistics Management*, Vol. 12, No. 2, pp. 13-36.

Davenport, Thomas H and Michael C. Beers (1995), "Managing Information about Processes," *Journal of Management Information Systems*, Vol. 12, No. 1, pp. 57-80.

Dillman, Don A. (2000), *Mail and Internet Surveys: The Tailored Design Method*, New York, NY: John Wiley & Sons.

Ellinger, Alexander E., Patricia J. Daugherty, and Scott B. Keller (2000), "The Relationship between Marketing/Logistics Interdepartmental Integration and Performance in U.S. Manufacturing Firms: An Empirical Study," *Journal of Business Logistics*, Vol. 21, No.1, pp. 1-22.

Fassinger, Ruth E. (1987), "Use of Structural Equation Modeling in Counseling Psychology Research," *Journal of Counseling Psychology*, Vol. 34, pp. 425-436.

Fawcett, Stanley E. and Gregory M. Magnan (2002), "The Rhetoric and Reality of Supply Chain Integration," *International Journal of Physical Distribution & Logistics Management*, Vol. 32, No. 5, pp. 339-351.

Fornell, Claes and David F. Larcker (1981), "Evaluating Structural Equation Models with Unobservable Variables and Measurement Error," *Journal of Marketing Research*, Vol. 18, No. 1, pp. 39-50.

Frohlich, Markham T. and Roy Westbrook (2001), "Arcs of Integration: An International Study of Supply Chain Strategies," *Journal of Operations Management*, Vol. 19, No. 2, pp. 185-200.

- Garver, Michael S. and John T. Mentzer (1999), "Logistics Research Methods: Employing Structural Equation Modeling to Test for Construct Validity," *Journal of Business Logistics*, Vol. 20, No. 1, pp. 33-57.
- Gerbing, David W. and James C. Anderson (1988), "An Updated Paradigm for Scale Development Incorporating Unidimensionality and Its Assessment," *Journal of Marketing Research*, Vol. 25, No. 2, pp. 186-192.
- Germain, Richard, Cornelia Dröge, and Patricia J. Daugherty (1994), "The Effects of Just-In-Time Selling on Organizational Structure: An Empirical Investigation," *Journal of Marketing Research*, Vol. 31, No.4, pp. 471-483.
- Glaser, Barney G. (2001), *The Grounded Theory Perspective: Conceptualization Contrasted with Description*, Mill Valley, CA: Sociology Press.
- Hair, Joseph F., Rolph E. Anderson, Ronald L. Tatham, and William C. Black (1998), *Multivariate Data Analysis*, 5<sup>th</sup> Ed., Upper Saddle River, NJ: Prentice Hall.
- Hall, Robert W. (1987), *Attaining Manufacturing Excellence*, Homewood, IL: Dow Jones-Irwin.
- Hammer, Michael (2001), "The Superefficient Company," *Harvard Business Review*, Vol. 79, No. 8, pp. 82-91.
- Hu, Li-Tze and Peter M. Bentler (1995), "Evaluating Model Fit," in *Structural Equation Modeling: Concepts, Issues, and Applications*, Rick H. Hoyle, ed., Thousand Oaks, CA: Sage Publications, pp. 76-99.
- Iyer, Karthik N.S., Richard Germain, and Gary L. Frankwick (2004), "Supply Chain B2B E-Commerce and Time-Based Delivery Performance," *International Journal of Physical Distribution & Logistics Management*, Vol. 34, No. 8, pp. 645-661.
- Johnson, Jean L. (1999), "Strategic Integration in Industrial Distribution Channels: Managing the Interfirm Relationship as a Strategic Asset," *Journal of Academy of Marketing Science*, Vol. 27, No. 1, pp. 4-18.
- Jöreskog, Karl G. and Dag Sörbom (1988), *LISREL VII: Analysis of Linear Structure Relationships by the Methods of Maximum Likelihood*, Mooresville, IN: Scientific Software.
- Jöreskog, Karl G. and Dag Sörbom (1989), *LISREL-7 User's Reference Guide*, Mooresville, IN: Scientific Software.
- Kahn, Kenneth B. and Edward F. McDonough (1997), "Marketing's Integration with R&D and Manufacturing: A Cross-Regional Analysis," *Journal of International Marketing*, Vol. 5, No. 1, pp. 51.



- Kahn, Kenneth B. and John T. Mentzer (1998), "Marketing's Integration with other Departments," *Journal of Business Research*, Vol. 42, No. 1, pp. 53-62.
- Lambert, Douglas M. (2004), *Supply Chain Management: Processes, Partnerships, Performance*, Sarasota, FL: Supply Chain Management Institute.
- Lambert, Douglas M., Sebastián J. García-Dastugue, and Keely L. Croxton (2005), "An Evaluation of Process-Oriented Supply Chain Management Frameworks," *Journal of Business Logistics*, Vol. 26, No. 1, pp. 25-51.
- Larson, Paul D. (1994), "An Empirical Study of Inter-organizational Functional Integration and Total Costs," *Journal of Business Logistics*, Vol. 15, No. 1, pp. 153-169.
- Lawrence, Paul R. and Jay Williams Lorsch (1967), *Organization and Environment: Managing Differentiation and Integration*, Boston, MA: Graduate School of Business Administration, Harvard University.
- Lee, Hau L. (2000), "Creating Value through Supply Chain Integration," *Supply Chain Management Review*, Vol. 4, No. 4, pp. 30-36.
- Lohr, Sharon L. (1999), *Sampling: Design and Analysis*, Pacific Grove, CA: Duxbury Press.
- Maloni, Michael and W.C. Benton (2000), "Power Influences in the Supply Chain," *Journal of Business Logistics*, Vol. 21, No. 1, pp. 49-63.
- McAdam, R. and D. McCormack (2001), "Integrating Business Processes for Global Alignment and Supply Chain Management," *Business Process Management Journal*, Vol. 7, No. 2, pp. 113-130.
- Mentzer, John T. and Daniel J. Flint (1997), "Validity in Logistics Research," *Journal of Business Logistics*, Vol. 18, No. 1, pp. 199-216.
- Mentzer, John T., Daniel J. Flint, and John L. Kent (1999), "Developing Logistics Service Quality Scale," *Journal of Business Logistics*, Vol. 20, No. 1, pp. 9-32.
- Min, Soonhong and John T. Mentzer (2004), "Developing and Measuring Supply Chain Management Concepts," *Journal of Business Logistics*, Vol. 25, No. 1, pp. 63-99.
- Mollenkopf, Diane and G. Peter Dapiran (2005), "World-Class Logistics: Australia and New Zealand," *International Journal of Physical Distribution & Logistics Management*, Vol. 35, No. 1, pp. 63-74.

Mollenkopf, Diane, Antony Gibson, and Lucie Ozanne (2000), "The Integration of Marketing and Logistics Functions: An Empirical Examination of New Zealand Firms," *Journal of Business Logistics*, Vol. 21, No. 2, pp. 89-112.

Morash, Edward A. and Steven R. Clinton (1998), "Supply Chain Integration: Customer Value through Collaborative Closeness versus Operational Excellence," *Journal of Marketing Theory and Practice*, Vol. 6, No. 4, pp. 104-120.

Narasimhan, Ram and Ajay Das (2001), "The Impact of Purchasing Integration and Practices on Manufacturing Performance," *Journal of Operations Management*, Vol. 19, No. 5, pp. 593-609.

Nunnally, Jum C. (1978), *Psychometric Theory*, 2<sup>nd</sup> Ed., New York, NY: McGraw-Hill, Inc.

O'Leary-Kelly, Scott W. and Benito E. Flores (2002), "The Integration of Manufacturing and Marketing/Sales Decisions: Impact on Organizational Performance," *Journal of Operations Management*, Vol. 20, No. 3, pp. 221-240.

Pagell, Mark (2004), "Understanding the Factors That Enable and Inhibit the Integration of Operations, Purchasing and Logistics," *Journal of Operations Management*, Vol. 22, No. 5, pp. 459-487.

Pagell, Mark, Robert B. Handfield, and Alison E. Barber (2000), "Effects of Operational Employee Skills on Advanced Manufacturing Technology Performance," *Production and Operations Management*, Vol. 9, No. 3, pp. 222-238.

Porter, Michael E. (1980), *Competitive Strategy: Techniques for Analyzing Industries and Competitors*. New York, NY: The Free Press.

Porter, Michael E. (1985), *Competitive Advantage: Creating and Sustaining Superior Performance*, New York, NY: The Free Press.

Prabhaker, Paul R., Joel D. Goldhar, and David Lei (1995), "Marketing Implications of Newer Manufacturing Technologies," *Journal of Business and Industrial Marketing*, Vol. 10, No. 2, pp. 48-58.

Rodrigues, Alexander M., Theodore P. Stank, and Daniel F. Lynch (2004), "Linking Strategy, Structure, Process and Performance in Integrated Logistics," *Journal of Business Logistics*, Vol. 25, No. 2, pp. 65-94.

Ross, Anthony (2002), "A Multi-Dimensional Empirical Exploration of Technology Investment, Coordination and Firm Performance," *International Journal of Physical Distribution & Logistics Management*, Vol. 32, No. 7, pp. 591-609.

- Ross, Anthony, M.A. Venkataramanan, and Kathryn W. Ernstberger (1998), "Reconfiguring the Supply Network Using Current Performance Data," *Decision Sciences*, Vol. 29, No. 3, pp. 707-728.
- Saaksjarvi, Markku V.T. and Jari M. Talvinen (1993), "Integration and Effectiveness of Marketing Information Systems," *European Journal of Marketing*, Vol. 27, No. 1, pp. 64-79.
- Sabath, Robert and Judith Whipple (2004), "Using the Customer/Product Action Matrix to Enhance Internal Collaboration," *Journal of Business Logistics*, Vol.25, No.2, pp. 1-19.
- Segars, Albert H., Warren J. Harkness, and William J. Kettinger (2001), "Process Management and Supply-Chain Integration at the Bose Corporation," *Interfaces*, Vol. 31, No. 3, pp. 102-114.
- Song, Michael and Jinhong Xie (2000), "Does Innovativeness Moderate the Relationship Between Cross-Functional Integration and Product Performance?" *Journal of International Marketing*, Vol. 8, No. 4, pp. 61-89.
- Stank, Theodore P., Scott B. Keller, and David J. Closs (2001), "Performance Benefits of Supply Chain Logistical Integration," *Transportation Journal*, Vol. 41, No. 2/3, pp. 32-46.
- Stank, Theodore P., Scott B. Keller, and Patricia J. Daugherty (2001), "Supply Chain Collaboration and Logistical Service Performance," *Journal of Business Logistics*, Vol. 22, No. 1, pp. 29-48.
- Stank, Theodore P. and Charles W. Lackey Jr. (1997), "Enhancing Performance through Logistical Capabilities in Mexican Maquiladora Firms," *Journal of Business Logistics*, Vol. 18, No. 1, p. 91-123.
- Stevens, Graham C. (1989), "Integrating the Supply Chain," *International Journal of Physical Distribution & Materials Management*, Vol. 19, No. 8, pp. 3-8.
- Stock, James R. (2002), "Marketing Myopia Revisited: Lessons for Logistics," *International Journal of Physical Distribution & Logistics Management*, Vol. 32, No. ½, pp. 12-21.
- Strauss, Anselm (1987), *Qualitative Analysis for Social Scientists*, New York, NY: Cambridge University Press.
- Strauss, Anselm and Juliet Corbin (1990), *Basics of Qualitative Research: Grounded Theory Procedures and Techniques*, London, UK: Sage.

Sundaram, R. Meenakshi and Sameer G. Mehta (2002), "A Comparative Study of Three Different SCM Approaches," *International Journal of Physical Distribution & Logistics Management*, Vol. 32, No. 7, pp. 532-555.

Trkman, Peter, Mojca Indihar Štemberger, Furiš Faklič, and Aleš Groznik (2007), "Process Approach to Supply Chain Integration," *Supply Chain Management: An International Journal*, Vol. 12, No. 2, pp. 116-128.

Widaman, Keith F. (1985), "Hierarchically Nested Covariance Structure Models for Multitrait-Multimethod Data," *Applied Psychological Measurement*, Vol. 9, No. 1, pp. 1-26.

Williamson, Oliver E. (1975), *Markets and Hierarchies, Analysis and Antitrust Implications: A Study in the Economics of Internal Organization*, New York, NY: Free Press.

Verma, Rohit, Gary M. Thompson, William L. Moore, and Jordan J. Louviere (2001), "Effective Design of Product/Services: An Approach Based on Integration of Marketing and Operations Management Decisions," *Decision Sciences*, Vol. 32, No. 1, pp. 165-193.

Youndt, Mark A., Scott A. Snell, James W. Dean Jr., and David P. Lepak (1996), "Human Resource Management, Manufacturing Strategy, and Firm Performance," *Academy of Management Journal*, Vol. 39, No. 4, pp. 836-866.

Zairi, Mohamed (1997), "Business Process management: A Boundaryless Approach to Modern Competitiveness," *Business Process Re-engineering & Management Journal*, Vol. 3, No. 1, pp. 64-80.

**APPENDIX A**  
**DEFINITIONS AND CATEGORIZATIONS OF INTEGRATION**

Authors	Definitions	Types/Dimensions/Stages
Ayers, Dahlstrom, and Skinner (1997)	The extent of information sharing and involvement across functional areas.	R&D and marketing integration: - Marketing involvement - Information exchange - Engineering involvement
Bagchi and Skjoett-Larsen (2003)		1) Information integration: - Information and knowledge exchange - Technology exchange and adaptation - Resource and risk sharing 2) Organizational integration: - Risk, cost, and gain sharing - Ideas and culture sharing - Decision-making sharing - Skill sharing - Trust building - Bonds creation
Barratt and Oliveira (2001)	Equates collaboration. Occurs when two or more companies share the responsibility of exchanging common planning, management, execution, and performance measurement information.	
Ellinger, Daugherty, and Keller (2000)	A series of interdepartmental interactions or contact-related activities, or as interdepartmental collaborative behaviors.	- Collaboration - Consultation - Information exchange
Fawcett and Magnan (2002)	True integration - where objectives are aligned, communication is open and candid, resources are pooled, and risks and rewards are shared remains rare. The more appropriate descriptors are cooperation and collaboration.	- Internal, cross-functional process integration - Backward integration - Forward integration - Complete forward and backward integration
Germain, Dröge, and Daugherty (1994)	Lateral links that coordinate differentiated subunits, reduce conflict and duplication, foster mutual adjustment, and coalesce subunits toward meeting overall organizational objectives.	- Integrative committees - Integrative mechanisms
Iyer, Germain, and Frankwick (2004)	Lateral communication within the firm and signifies the level of coordination among different work units and functions.	
Johnson (1999)	Strategic integration is a progressive involvement between two firms in a relationship that implies combined resources, expanded joint capabilities, and enhanced competitive positions for the firms involved; in addition, it results in explicit and acknowledged strategic consequences for the individual firm and a strategic role for the relationship formally specified by the individual firm.	

Kahn and Mentzer (1998)	A process of interdepartmental interaction and interdepartmental collaboration that brings departments together into a cohesive organization.	<ul style="list-style-type: none"> <li>- Interdepartmental interaction</li> <li>- Interdepartmental collaboration</li> </ul>
Larson (1994)	Inter-organizational functional integration is defined as buyer/supplier cooperation in performing activities necessary to create utility	
Lawrence and Lorsch (1967)	The quality of the state of collaboration that exists among departments that are required to achieve unity of effort by the demands of the environment	
Lee (2000)		3 dimensions: <ul style="list-style-type: none"> <li>- Information integration</li> <li>- Coordination and resource sharing</li> <li>- Organizational relationship linkage</li> </ul>
Mollenkopf and Dapiran (2005) Stank, Keller, and Closs (2001) Stank and Lackey (1997)	<ul style="list-style-type: none"> <li>- Customer Integration: Building lasting distinctiveness with customers of choice.</li> <li>- Internal Integration: The competency of linking internally performed work into a seamless process to support customer requirements.</li> <li>- Material/Service Supplier Integration: The competency linking externally performed work into a seamless congruency with internal work processes.</li> <li>- Technology and Planning Integration: The competency of maintaining information systems capable of supporting the wide variety of operational configurations needed to serve diverse market segments.</li> <li>- Measurement Integration: Development and maintenance of measurement systems that facilitate segmental strategies and processes.</li> <li>- Relationship Integration: The competency to develop and maintain a shared mental framework with customers and suppliers regarding inter-enterprise dependency and principles of collaboration.</li> </ul>	<ul style="list-style-type: none"> <li>- Customer Integration</li> <li>- Internal Integration</li> <li>- Material/Service Supplier Integration</li> <li>- Technology and Planning Integration</li> <li>- Measurement Integration</li> <li>- Relationship Integration</li> </ul>
Mollenkopf, Gibson, and Ozanne (2000)		<ul style="list-style-type: none"> <li>- Information dissemination</li> <li>- Coordinating of activities</li> </ul>
Morash and Clinton (1998)	<ul style="list-style-type: none"> <li>- Intra-firm process integration: intra-organizational customer demand requirements and supply capabilities must be aligned and balanced in order to create unified value for ultimate customers.</li> <li>- Inter-organizational collaborative closeness involves close and long-term relationships with a firm's external customers, suppliers, and partners. These integrative relationships may extend the boundaries of the firm to embrace materials and logistics service</li> </ul>	3 forms: <ul style="list-style-type: none"> <li>- Intra-firm process integration</li> <li>- Inter-organizational collaborative closeness</li> <li>- Inter-organizational operational excellence</li> </ul>

	suppliers and customers such that exact boundaries between firms become blurred. - Inter-organizational operational excellence emphasizes the physical, spatial, temporal, and economic nature of supply chain integration.	
Rodrigues, Stank, and Lynch (2004)	Internal integration is achieved by linking operations into a seamless, synchronized operational flow, encouraging front-line managers and employees to use their own discretion, within policy guidelines, to make timely decisions.  External integration synchronizes the core competencies of selected supply chain participants to jointly achieve improved service capabilities at lower total supply chain cost.	- Internal integration - External integration
Ross (2002)	Equates coordination.	- Labor productivity - Administrative productivity
Saaksjarvi and Talvinen (1993)	A realized possibility to get separate components of parts of a system to work effectively together.	Marketing information systems: - Technical integration - Functional integration
Song and Xie (2000)	The effective unity of effort by different functional departments. The degree of integration refers to the degree of cross-functional interaction in generating and disseminating market and competitive intelligence, as well as the degree of cross-functional information sharing, coordination, and joint involvement in specific tasks	
Stevens (1989)		4 stages: - Fragmented operations within the individual company - Limited integration between adjacent functions - Internal integration of the end-to-end planning within the individual company - True supply chain integration including upstream and downstream players
Sundaram and Mehta (2002)	An association of customers, retailers, distribution centers/warehouses, and manufacturers using techniques enabling them to work together to optimize their collective performance in the creation, distribution, and support of the end product.	Internal and external integration 3 approaches: - Independent - Semi-integrated - Integrated

**APPENDIX B**  
**RESPONDING FIRM DEMOGRAPHICS**

	Number of Firms	Percentage
<b>Firm Type</b>		
State-owned	51	16.8%
Private	140	46.1%
Foreign invested	82	27.0%
Unidentified	31	10.1%
<i>Total</i>	<i>304</i>	<i>100%</i>
<b>Firm Employee Size</b>		
100 – 500	72	23.7%
501 – 1,000	69	22.7%
1,001 – 5,000	83	27.3%
> 5000	38	12.5%
Unidentified	42	13.8%
<i>Total</i>	<i>304</i>	<i>100%</i>
<b>Firm Annual Sales (2006) (in million RMB*)</b>		
10 – 100	71	23.4%
101 – 1,000	89	29.3%
1,001 – 10,000	68	22.4%
> 10,000	35	11.5%
Unidentified	41	13.4%
<i>Total</i>	<i>304</i>	<i>100%</i>

\* Ren Min Bi (RMB) is the Chinese currency unit. During the data collection, the exchange rate between US Dollar and RMB was about 1:7.8.



**APPENDIX C.  
RESPONDENT PROFILE**

	Number of Respondents	Percentage
<b>Position</b>		
President (or General Manager)	65	21.4%
Vice President (or Vice General Manager)	113	37.2%
Director	89	29.3%
Manager	37	12.1%
<i>Total</i>	<i>304</i>	<i>100%</i>
<b>Years in Current Position</b>		
1 – 5	140	46.1%
5 – 10	82	27.0%
>10	52	17.1%
Unidentified	30	9.8%
<i>Total</i>	<i>304</i>	<i>100%</i>
<b>Years with Current Company</b>		
1 – 5	128	42.1%
5 – 10	90	29.6%
>10	52	17.1%
Unidentified	34	11.2%
<i>Total</i>	<i>304</i>	<i>100%</i>

# **CUSTOMER ORIENTATION, SERVICE INNOVATIVE CAPABILITY, AND FIRM PERFORMANCE: IS SUPPLY CHAIN PROCESS INTEGRATION A MISSING LINK?**

## **1. Introduction**

In essence, the entire concept of supply chain management (SCM) is predicated on integration (Frohlich and Westbrook, 2001; Pagell, 2004). Cross-organizational processes must be managed and coordinated in order to provide requisite customer value. Recent OM research has addressed important integration-related issues; however, significant research voids still exist (Pagell, 2004). For example, even though OM researchers acknowledge integration's contributions both within a firm and across firms (e.g. Das et al., 2006; Swink et al., 2007), few studies have examined internal integration and external integration simultaneously (e.g. Frohlich and Westbrook, 2001; Dröge et al., 2004). Our study attempts to address the issue by examining internal process integration and external process integration in one framework.

Customer orientation and innovation have emerged as key concepts relevant to SCM. Because of their prominence within the literature and documented impact on business (e.g. Deshpande et al., 1993), these two constructs were selected for closer examination. Specifically, the research seeks to determine whether supply chain process integration is necessary to fully exploit the potential impact of customer orientation in developing service innovative capability. Previous research has supported the positive impact of supply chain integration on performance (e.g. Stank et al., 1999; Frohlich and Westbrook, 2001; Gimenez and Venture, 2003; Min and Mentzer, 2004; Swink et al., 2007). However, researchers have called for a more robust explanation of the

integration-performance relationship (Ettlie and Reza, 1992; Swink and Nair, 2007). Thus, the current study examines supply chain process integration's role utilizing a well-recognized marketing framework: the customer orientation-innovation-performance framework (Deshpande et al., 1993; Han et al., 1998). Although customer orientation has appeared in OM studies (e.g. Sousa, 2003; Chen and Paulraj, 2004; Droge et al., 2004), its impact on supply chain process integration deserves more attention. Innovation, too, deserves closer examination.

It is widely believed that innovation can occur in products, processes, and services (e.g. Amabile et al., 1996; Lumpkin and Dess, 1996). However, to date, OM researchers have mainly focused on product innovation (e.g. Koufteros et al., 2001; Calantone et al., 2002; Swink et al., 2006, Swink and Song, 2007) and process innovation (e.g. Das and Joshi, 2007; Khazanchi et al., 2007) with little attention to service innovation. This is surprising considering service is an important differentiator for companies (Christopher, 2005) and service innovation has received more attention recently in areas such as logistics and marketing (Flint et al., 2005; Berry et al., 2006; Jana, 2007).

The paper is organized as follows. First, key concepts are defined and discussed based on literature review and synthesis. Then, theoretical background and hypotheses development are presented, followed by research methodology and analysis. Finally, results, implications, and limitations of the study are presented.

## **2. Key concepts**

Relevant literature is first reviewed and synthesized to provide the foundation for conceptualizing the key constructs.

## *2.1 Supply chain process integration*

No single widely accepted definition or operationalization of integration has been developed to date. Integration is often considered conceptually interchangeable with coordination (e.g. Alder, 1995; Frohlich and Westbrook, 2001; Swink and Song, 2007) or collaboration (e.g. Ettlir and Stoll, 1990; Mintzberg et al., 1996). Integration definitions also vary with the specific research context. In the OM literature, much of the research focuses on integration between different functional areas within a firm, such as manufacturing-marketing (e.g. O'Leary-Kelly and Flores, 2002), operations-marketing (e.g. Verma et al., 2001), design-manufacturing (e.g. Swink and Nair, 2007), marketing-R&D (e.g. Gupta et al., 1986), R&D-manufacturing (e.g. Swink, 1999), marketing-manufacturing (e.g. Swink and Song, 2007), and R&D-manufacturing-marketing (Song et al., 1998). In a cross-firm context, research has mainly centered on customer integration and supplier integration (e.g. Das et al., 2006; Swink et al., 2007). While previous research has contributed to a better understanding of integration, a simple definition applicable to different scenarios can be helpful for guiding future research.

As discussed previously, the focus of the current study is supply chain process integration. The process approach toward supply chain integration is best manifested in the Supply Chain Council's popular Supply Chain Operations Reference-model (SCOR) that suggests that business should be managed based on key processes – plan, source, make, deliver, and return (see [www.supply-chain.org](http://www.supply-chain.org)). Similarly, the Global Supply Chain Forum also proposed that it is necessary to identify the relevant business processes and manage them effectively (Lambert, 2004). As Pagell (2004) suggested, various definitions and operationalizations of integration share common themes and tend

to overlap. An extensive literature synthesis yielded two key components of process integration: *process connectivity* and *process simplification*.

*Process connectivity* refers to the linkages among relevant business processes. The importance of connectivity is highlighted in Porter's (1980, 1985) value chain model with emphasis on the linkages between processes. Schmenner and Swink's (1998) theory of swift, even flows also postulated that the most successful operations smoothly move raw materials and subassemblies through processes and into finished goods. Further, raw materials, work-in-process, and finished goods only move swiftly when there are no flow impediments in the way; productivity rises proportionally to the speed that materials move through processes. Therefore, researchers have considered linkages or connectedness as a key component in their conceptualizations of integration (e.g. Germain et al., 1994; Lambert et al., 2005).

*Process simplification*, another key theme of process integration found in the literature, refers to eliminating duplicate or unnecessary processes or steps in processes. Process simplification involves eliminating non-value-adding activities from internal and external processes including the seven classic wastes of Shigeo Shingo: overproduction, waiting, transportation, unnecessary processing steps, stocks, motion, and defects (Hall, 1987; Frohlich and Westbrook, 2001). Process integration can be achieved by establishing and adhering to common operational policies and procedures (Bowersox et al., 1999; Dröge et al., 2004). Through the use of standard procedures, materials, parts, and/or processes, situations such as "reinventing the wheel" or "starting from scratch" can be avoided, thus preventing unnecessary complexity and achieving simplification

(Dröge et al., 2004). Joint planning and decision-making is also critical in process simplification (cf. Song and Xie, 2000; Barratt and Oliveira, 2001).

Thus, *supply chain process integration* is defined as managing a set of activities that aims at seamlessly linking relevant business processes within and across firms and eliminating duplicate or unnecessary processes for the purpose of building a better-functioning supply chain. Because internal process integration and external process integration involve different organizational ownerships, structures, participants, activities, and mechanisms, they differ significantly in terms of scope and content. For example, the integration of a firm's production process with an *internal* parts supplier would be significantly different from with an *external* parts supplier, because the parties involved in an external integration context often differ in terms of organizational policies, routines, values, and culture. Therefore, *internal process integration* and *external process integration* are viewed as two separate constructs (e.g. Gimenez and Ventura, 2003, 2005; Dröge et al., 2004; Germain and Iyer, 2006), each with two dimensions – *process connectivity* and *process simplification*.

## 2.2. Customer orientation

Marketing researchers have emphasized the importance of customer orientation to business success (e.g. Lawton and Parasuraman, 1980; Deshpande et al., 1993). More explicitly, Kohli and Jaworski (1990) argued that the activities of generating market intelligence pertaining to current and future customer needs, disseminating the intelligence across departments, and responding to it are critical to the success of a firm. Drawing upon the conceptualizations provided by Narver and Slater (1990) and Deshpande et al. (1993), *customer orientation* is defined here as a corporate culture that

reflects a firm's strategic priority focusing on understanding customer needs and continuously creating customer value. While a firm may have various business orientations, the focus here is to examine customer orientation as a strategic priority. A strong customer orientation implies that a firm proactively seeks information on customer preferences and needs, and tries to be responsive (Vickery et al., 2003). In reality, however, customer orientation is often over-shadowed by other business priorities, such as a low cost orientation. Switching call centers to overseas to cut the operating costs is an example (Friedman, 2005).

In the OM literature, the theoretical importance of customers is often discussed (e.g. Chen and Paulraj, 2004); but few studies have empirically examined customer orientation as a corporate culture. For example, Sousa (2003) investigated customer focus practices in quality management, and Vickery et al. (2003) concluded that customer service fully mediates the relationship between supply chain integration and firm performance. In order to further explore customer orientation's critical role, the current study empirically examines customer orientation's impact on supply chain process integration.

### *2.3. Service innovative capability*

Innovation has been defined as the generation, acceptance, and implementation of new ideas, processes, products, or services (Thompson, 1965; Amabile et al., 1996; Lumpkin and Dess, 1996; Roy et al., 2004). Although past conceptualizations describe innovation as a set of activities or actions, it is suggested here that innovation in essence is a type of firm capability. Innovation research has largely focused on new product-related breakthroughs (Han et al., 1998); however, product innovation entails developing

both new products and services (Khanzanchi et al., 2007). In spite of this, service innovation has been given little attention in the OM literature. Service innovation warrants more attention. In order to respond to fast-changing customer demands and competitive market environments, firms must be creative in offering innovative services to create unique value for customers and to differentiate themselves from the competition.

To better reflect the conceptualization of service innovation as a type of firm capability, the current study examines a firm's *service innovative capability*, which is defined as a firm's ability to develop and offer new services or service-related processes to create superior value for supply chain members, including final consumers. Das and Joshi's (2007) study suggested that innovation is crucial to service firms. As Christopher (2005) noted, manufacturing companies should also pay more attention to service innovation. For example, as an industry leader, Caterpillar focused for many years on developing its customer service as well as manufacturing capability and innovative products. Its promise to provide 48-hour availability on parts no matter how remote the location helped the company to remain competitive.

### **3. Theoretical background and hypotheses development**

The current study is grounded in two widely applied theoretical frameworks – the strategy-structure-performance (SSP) framework and resource based view of firms (RBV). The basic tenet of the SSP framework is that a firm's strategy drives the development of organizational structure and process (Galbraith and Nathanson, 1978; Miles and Snow, 1978; Galunic and Eisenhardt, 1994); and the fit between the strategy and structure of a firm leads to better performance because structure provides the



systems and processes essential for successful strategy implementation (e.g. Grinyer et al., 1980; Habib and Victor, 1991). RBV considers firms as bundles of distinct resources (Wernerfelt, 1984). Firms are able to generate rents or competitive advantage by developing unique firm resources and capabilities (Barney, 1991; Day, 1994). However, previous research has pointed out that the alignment of strategy and structure is only a baseline requirement for organizational performance (Miles and Snow, 1978; Galbraith and Kazanjian, 1986), and a minimal fit is required for firm survival (Miles and Snow, 1984). In other words, the fit between strategy and structure is a necessary but not sufficient condition for superior firm performance. Combining these two theoretical frameworks, it is proposed that strategy and structure fit can help to improve performance by developing necessary capabilities. This argument is in line with Stock et al.'s (1998) study, linking firm strategy, structure, logistics capabilities, and performance. While customer orientation can be considered as a corporate culture reflecting firm strategy (Deshpande et al., 1993), supply chain process integration can be viewed as a set of restructuring activities that realigns a firm's internal and external structure to better allocate resources (Thompson, 1967; Hall and Saias, 1980). Thus, a conceptual model based on SSP and RBV is proposed as shown in Fig. 1.

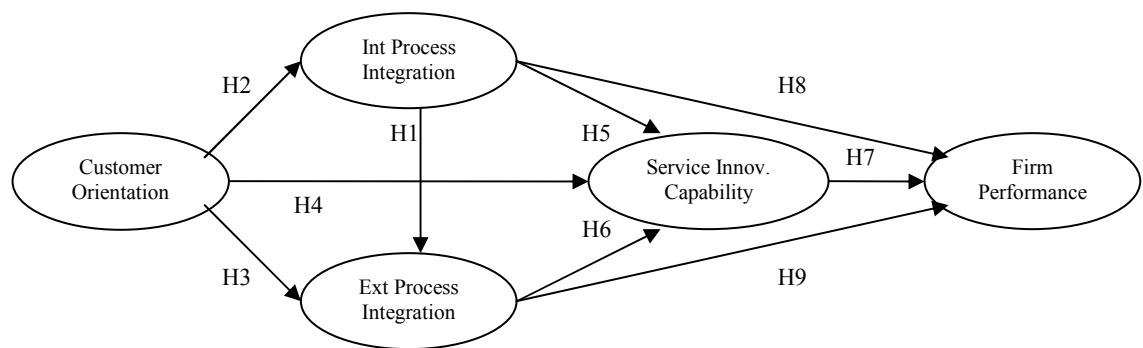

Fig. 1. Proposed conceptual model

### *3.1. Internal process integration and external process integration*

In the OM literature, few empirical studies have simultaneously examined integration internally and externally. Although different concepts, internal process integration and external process integration are closely linked (e.g. Das et al., 2006). However, the sequence or the causal link between the two has not been empirically tested. Dröge et al. (2004) explored internal and external integration's effects on time-based performance and firm performance; however, they did not address the relationship between internal and external integration. Stevens (1989) emphasized that true supply chain integration includes both upstream and downstream players, but internal integration provides the foundation. Anecdotal accounts from practitioners suggest that internal process integration is the first step toward achieving external process integration (e.g. Handfield and Nichols, 1999; Rosenzweig, et al., 2003). The mutual interdependence between internal process integration and external process integration requires internal cohesiveness and coordination (Wagner, 2003). Thus, Das et al. (2006) argued that supplier integration (a type of external process integration) begins with internal integration practices. By the same token, Gimenez (2006) suggested that the inability to fully integrate a firm's internal operations is a leading cause of external arrangement failures. Firms must achieve a relatively high level of integration among internal functions before they can fully integrate externally with other supply chain members (Lambert et al., 1998; Min and Mentzer, 2004). Therefore,

*H1. A firm's internal process integration leads to its external process integration.*

### *3.2. Customer orientation's impacts*

The SSP framework suggests that a firm's strategic direction develops from an awareness of opportunities and needs (Chandler, 1962). However, a firm may need to restructure operations to implement a chosen strategy. When a firm fully embraces customer orientation as its strategic priority, all functional activities and organizational processes focus toward anticipating and responding to changing market and customer requirements ahead of competitors. Researchers have suggested that the customer orientation naturally leads to integrating all functions within a firm (Felton, 1959). More specifically, creating value for customers involves the synergistic efforts of the entire business and not merely of a single department or function (Webster, 1988; Narver and Slater, 1990). When personnel from different areas have a strong customer orientation, the aligned goals and values lead to less conflict regarding expectations and practices (c.f. Swink and Song, 2007). Researchers, thus, have argued that the coordinated integration of the business's resources is closely tied to customer orientation (Wind and Robertson, 1983; Narver and Slater, 1990).

*H2. A firm's customer orientation has positive impact on its internal process integration.*

Customer orientation also facilitates external supply chain process integration. In a supply chain context, in order to create value for a buyer, the seller must have sufficient information and knowledge about constraints at all levels in a supply chain (c.f. Narver and Slater, 1990). This kind of understanding and communication enables supply chain participants to identify the interfaces that need to be connected and the duplicate processes that can be eliminated. Further, customer orientation fosters collaborative external relationships. With a strong customer orientation, a firm is more

likely to develop customer closeness as a distinctive capability (Day, 1994). Traditional transactional buyer-seller relationships are likely to be replaced with collaborative relationships. In turn, collaborative relationships can facilitate the connection and simplification of business processes across firm boundaries. Furthermore, because customer orientation places the highest priority on continuously finding ways to provide superior customer value, an increased commitment to customer orientation should result in increased boundary-spanning activities (Pierce and Delbecq, 1977; Han et al., 1998). Therefore,

*H3. A firm's customer orientation has positive impact on its external process integration.*

Drucker (1954, p. 37) stated that: "There is only one valid definition of business process: to create a customer..." Creating rather than serving a customer implies innovation – the creation of innovative products and services (Berthon et al., 1999). Marketing scholars have proposed a positive link between customer orientation and innovation (Deshpande et al., 1993; Jaworski and Kohli, 1996; Hurley and Hult, 1998). A customer orientation essentially involves doing something new or different in response to customer requirements (Jaworski and Kohli, 1993). Close customer relationships and the dialogue between the firm and its customers help to identify issues and sources of ideas necessary to foster significant innovation (Hurley and Hult, 1998; Connor, 1999). Thus, Deshpande et al. (1993) argued that the most important manifestation of customer orientation may be the success of innovations. In a SCM context, Flint et al.'s (2005) qualitative study revealed that customer-specific information gathering significantly improves logistics service innovation. In sum, with a strong customer orientation, a firm is likely to be more proactive in seeking information

about customer requirements and to try to satisfy customers by offering unique and innovative services. Thus,

*H4.* A firm's customer orientation has positive impact on its service innovative capability.

### *3.3. Supply chain process integration and service innovative capability*

In their study exploring the roots of innovation, Gatignon and Xuereb (1997) considered innovativeness as the outcome of a firm's resources. As discussed previously, internal and external process integration are the restructuring activities used to better allocate resources. According to RBV, this type of resource realignment can help develop distinctive capabilities, such as service innovative capability (c.f. Grant, 1991).

First, process integration supports the development of service innovative capability from a relationship perspective. Argyris (1982) suggested that organizational participants typically face uncertainty in dealing with innovations, which is amplified by the absence of preestablished rules or procedures to follow. In such situations, internal process integration helps mitigate distrust and conflicts among the functional units, which in turn provides an environment more receptive to innovation (Han et al., 1998). Studies have suggested that an effective interfunctional relationship can help a firm achieve organizational innovativeness through interfunctional coordination (Zaltman et al., 1973; Argyris, 1982; Gupta et al., 1986; Ruekert and Walker 1987; Olson et al., 1995).

Second, process integration provides a structure that facilitates and enhances service innovation. Concurrent engineering, the simultaneous generation of product and process designs in the early stages of new product development (Koufteros et al., 2001), provides an example of process integration. Cross-functional teams, used extensively in

concurrent engineering, help to ensure that innovative objectives are realized (Clark and Wheelwright, 1992; Hitt et al., 1999). The flattened structure speeds up the decision process and promotes cooperation and buy-in from all parties (Bishop, 1999; Vickery et al., 2003). Different areas within a firm, its suppliers, and its customers work together to simplify the new product development process (Handfield et al., 1999; Swink, 1999; Atuahene-Gima and Evangelista, 2000). Thus, concurrent engineering has been found to significantly contribute to a firm's innovative capabilities (Koufteros et al., 2001; Tan and Vonderembse, 2006).

Lastly, process integration contributes to service innovative capability through knowledge sharing and generation. According to the European Commission (1996), "Innovation is a result of an interactive learning process that involves often several actors from inside and outside the companies" (p. 54). Process integration facilitated by communication and information sharing makes knowledge creation (especially technical knowledge and tacit knowledge) possible and effective (Hage, 1980; Daugherty et al., 1995; Kusunoki and Namagami, 1998; Roy et al., 2004; Swink and Nair, 2007). A variety of expertise can be combined to create new knowledge (Kogut and Zander, 1992; Grant, 1996; Rosenzweig, et al., 2003). Each party brings a different interpretation of the same data as well as different and complementary data to the process, thus facilitating active learning (Flint et al., 2005). As an example, manufacturing personnel are often thought to be too detail oriented and locked-in to conventional solutions and technologies (e.g. Gerwin, 1993; Adler, 1995; Olson et al., 2001), while marketing people are often criticized as having little knowledge of manufacturing processes (e.g. Calantone et al., 2002). However, when the new product development related business

processes in these two areas are integrated, as shown in Swink and Song's (2007) study, new product competitive advantage is significantly improved, indicating a higher level of innovative capability. Many OM researchers have explicitly posited that external process integration (such as supplier integration and customer integration) is vital to a firm's innovation process (e.g. Smith and Reinertsen, 1998; Batenburg and Rutten, 2003; Dröge et al., 2004), because integrating with external partners provides the opportunity to access superior outside technological expertise (c.f. Narasimhan and Das, 1998). Thus, a strong service innovative capability is likely to be developed through process integration.

*H5.* A firm's internal process integration has positive impact on its service innovative capability.

*H6.* A firm's external process integration has positive impact on its service innovative capability.

#### *3.4. Service innovative capability and firm performance*

RBV suggests that distinctive capabilities can contribute to a firm's competitive advantage and improved performance (Barney, 1991). Prahalad and Hamel (1990) further articulated that sustained competitive advantage is achieved by core competencies which involve "the collective learning in the organization, especially how to coordinate diverse product skills and integrate multiple streams of technology" (p. 92). Because the development of a firm's service innovative capability relies on a particular infrastructure, history, and collective experience of a specific organization or a set of organizations, it is especially difficult for competitors to imitate (Barney, 1991; Kogut and Zander, 1992; Peteraf, 1993; Grant, 1996). More specifically, service innovative capability rooted in process integration involves complex development

procedures and knowledge contributions from various parties within and outside a firm, making it a superior distinctive capability. Many studies have supported the positive linkage between innovative capability and better performance (e.g. Deshpande et al., 1993; Han et al., 1998; Das and Joshi, 2007).

Furthermore, the intangible nature of service itself makes it more difficult for competitors to understand and copy the development of service advantages (Daugherty et al., 1992). In an environment where most products can be easily copied, price competition becomes very risky, and promotions have been used to the point of abuse in many industries (Daugherty et al., 1998). Therefore, a firm's service innovative capability becomes especially valuable. A firm is more likely to achieve superior competitive positioning in the market with a strong service innovative capability. It is thus proposed that,

*H7. A firm's service innovative capability has positive impact on firm performance.*

### *3.5. Supply chain process integration and firm performance*

As discussed previously, process integration is the restructuring of activities in order to allocate resources more effectively. According to RBV, heterogeneous resource arrangements through process integration can help a firm achieve competitive advantage (Barney, 1991). Integrating business processes across the supply chain in a manner that most competitors cannot easily match has been suggested as key to competitive success (Anderson and Katz, 1998; Birou et al., 1998). Researchers have empirically supported the direct positive relationships between internal and external integration and firm performance (e.g. Gimenez and Ventura, 2003; Gimenez and Ventura, 2005; Germain and Iyer, 2006). In his value chain framework, Porter (1980, 1985) advocated the



strategic exploitation of linkages within a firm's value chain (internal process integration) as well as between the firm's value chain and the value chains of its suppliers and customers (external process integration). Porter further emphasized the importance of optimizing external linkages, because such integration can directly enhance firm performance (e.g. Johnson, 1999; Tan et al., 1998; Vickery et al., 2003). Frohlich and Westbrook (2001) found that outward-facing supply chain integration (the broadest integration with both suppliers and customers) is associated with the largest rates of significant performance improvements.

Supply chain process integration through better coordination directly translates into reduced variability which in turn leads to greater efficiency (Metters, 1997; Lee and Tang, 1998; Frohlich and Westbrook, 2001). Process integration also improves efficiency by ensuring that operational interfaces within and between firms are synchronized to reduce duplication, redundancy, and dwell time (Rodrigues et al., 2004). In particular, process integration can improve a firm's efficiency in areas such as better inventory management, cost reduction, lead time reduction, etc. (e.g. Best and Segar, 1989; Gustin et al., 1994; Daugherty et al., 1996; Sutton, 1997; Narasimhan and Jayaram, 1998; Stank et al., 2001). For example, process integration supported with Advanced Planning and Scheduling (APS) can enhance facility, equipment, and inventory utilization (Stank et al., 2001). Another example is that automatic replenishment programs (ARPs), a process integration practice in which buyers and sellers manage inventory collaboratively, have been found to be related to greater efficiency and lower costs (Ellinger et al., 1999). In addition, Maloni and Benton (2000) found that buyer-seller integration could help firms achieve cost savings in the following

areas: economies of scale (in ordering, production, and transportation), decreased administration costs, decreased switching costs, and improved asset utilization.

Process integration also enhances a firm's effectiveness in terms of customer responsiveness, agility, delivery speed/reliability/quality, and so on (e.g. Gustin et al., 1994; Stank et al., 2001; Paulraj and Chen, 2007). Ellinger et al. (2000) found that marketing-logistics integration significantly contributed to a firm's performance (in terms of profitability, sales growth, and customer satisfaction) by improving distribution service level. Improved effectiveness emphasizes a firm's ability to respond in a timely manner to customers' needs and wants. Thus, it is directly linked to greater customer satisfaction. This contributes to better firm performance, because satisfied customers are likely to make repeat purchases and be willing to pay premium prices for high-quality products and services (Paulraj and Chen, 2007). Thus,

*H8. A firm's internal process integration has direct positive impact on its performance.*

*H9. A firm's external process integration has direct positive impact on its performance.*

## **4. Methodology**

### *4.1. Research design and data collection*

Survey data were collected in China to test the proposed model. Since China has emerged as one of the world's key manufacturing hubs in recent years; Chinese firms play increasingly important roles in global supply chains. Thus, China provides a viable and meaningful research context.

All scale items used and their descriptive statistics are shown in the Appendix. *Customer orientation* was measured with items adapted from Deshpande and Farley

(1998). *Firm performance* relative to major competitors was measured with items based on Claycomb et al. (1999) and Jaworski and Kohli (1993). Because accurate performance data were not publicly available for most Chinese companies, subjective measures of performance are considered appropriate in this situation (Dess and Robinson, 1984). Further, in the OM literature, Ketokivi and Schroeder (2004) concluded that reliability and validity of perceptual performance measures are satisfactory based on their multitrait-multimethod analysis.

Because the current study provides new definitions of *internal process integration* and *external process integration*, existing integration measures were not considered appropriate. Also, there are no existing scales to measure *service innovative capability*. The approach suggested by Churchill (1979) was thus followed to develop scales for these three constructs. First, extant literature and in-depth interviews with SCM executives (16 Chinese managers and 25 U.S. managers) were utilized to develop the initial pool of measurement items. Interview results confirmed two key dimensions of process integration – *process connectivity* and *process simplification*. A subset of items was selected from the item pool based on the criteria of uniqueness and ability to convey different meanings to respondents through content and face validity tests (Churchill, 1979).

Then, the proposed survey including newly developed and existing measures was subjected to review by six academic experts and 15 Chinese managers in the SCM field to assess face validity (Heeler and Ray, 1972). Based on their inputs, questions that were ambiguous or did not relate to the construct of interest were reworded or eliminated, and others were added. Lastly, a pilot study of the survey was conducted with 30 SCM

managers; the statistical analysis of the pilot data showed that most items loaded on expected constructs. Scale items with low reliability or cross loadings were deleted or reworded in order to ensure construct reliability and validity.

The original scale items were first developed in English, then five highly qualified native Chinese experts (all hold either Ph.D. in business or MBA from the U.S.) helped translate the final copy of the survey from English into Chinese. A final copy of the Chinese version was developed based on the synthesis of their translation. The Chinese version was also back translated into English and compared with the original English copy, and the result indicated satisfactory equivalency of both versions. A single industry – the electronics manufacturing industry – was chosen to control possible industry specific factors and generate more valid results.

In order to improve the efficiency of data collection, a dedicated web link through [www.zoomerang.com](http://www.zoomerang.com) was made available in addition to a traditional mail survey. The respondents had the option to complete the survey either with hard copy or online. An initial list of potential respondents was randomly generated from several electronics industry directories. Potential respondents were first contacted with a telephone call to confirm their contact information. Surveys were sent to a total of 900 potential respondents, and up to three follow-up phone calls were made to each person.

#### *4.2. Response to the survey*

During the three-month period, a total of 362 completed surveys were received. Of these, 58 questionnaires were eliminated for the following reasons: (1) too much missing data; (2) the company was not in the electronics manufacturing industry; (3) the respondent did not hold a qualifying position within the company; and (4) scoring 4 or

lower on a qualifying question – “I had enough information to answer all the questions (1 = Strongly Disagree, 4 = Neutral, and 7 = Strongly Agree).” This resulted in 304 usable responses, representing a 33.8% response rate (304/900). All items were submitted to *t*-tests to compare mail (141) and online (163) responses. The results showed no significant difference. Boyer et al.’s (2002) study found that print and electronic surveys generate statistically similar results in terms of reliability and validity and suggested that the two methods are largely inter-changeable. Therefore, it was determined that all usable responses could be analyzed as a single data set. Company information is detailed in Table 1.

Table 1.  
Responding firm demographics

	Number of Firms	Percentage
Firm Type		
State-owned	51	16.8%
Private	140	46.1%
Foreign invested	82	27.0%
Unidentified	31	10.1%
<i>Total</i>	<i>304</i>	<i>100%</i>
Firm Employee Size		
100 – 500	72	23.7%
501 – 1,000	69	22.7%
1,001 – 5,000	83	27.3%
> 5000	38	12.5%
Unidentified	42	13.8%
<i>Total</i>	<i>304</i>	<i>100%</i>
Firm Annual Sales (2006) (in million RMB*)		
10 – 100	71	23.4%
101 – 1,000	89	29.3%
1,001 – 10,000	68	22.4%
> 10,000	35	11.5%
Unidentified	41	13.4%
<i>Total</i>	<i>304</i>	<i>100%</i>

\* Ren Min Bi (RMB) is the Chinese currency unit. During the data collection, the exchange rate between US Dollar and RMB was about 1:7.8.

#### *4.3. Non-response bias*

Even with a relatively high response rate, non-response bias can exist with survey research (Lohr, 1999). Thus, potential non-response bias was examined with two approaches. One commonly used means is to compare early and late responses, because it is assumed that late respondents are more characteristic of non-respondents than early respondents (Armstrong and Overton, 1977). A multivariate *t*-test of all the items used to compare early and late respondents showed no significant difference. Second, 30 non-respondents were randomly selected and sent an abbreviated version of the survey (Mentzer and Flint, 1997; Lohr, 1999). Follow-ups were made to ensure that all completed this survey. The comparison between respondents' answers and non-respondents' answers with *t*-test yielded no significant difference. Therefore, it is concluded that non-response bias was not a concern.

#### *4.4. Key informant issue*

Efforts were made to ensure that survey respondents were knowledgeable and appropriate key informants (Campbell, 1955). First, all surveys were addressed to executives in relevant areas (including supply chain management/logistics, marketing, operations, and manufacturing) within their companies. It was assumed that the managers were familiar with their companies' supply chain management practices and able to answer the questions of interest. Furthermore, all were asked to indicate their positions in the survey. The responses from those who did not identify their positions or did not have qualifying positions were eliminated. In addition, as previously mentioned, a qualifying question regarding the informants' information adequacy helped to ensure

all respondents were qualified to answer the questions. Detailed information about the respondents is shown in Table 2.

All respondents were also asked to identify two of their major customers so that these customers could help to ensure the validity of the respondents' answers. Most Chinese firms perceive their account information as proprietary; only 41 firms provided complete contact information for their major customers. A corresponding survey was sent to the contacts in the customer firms to assess their suppliers' customer orientation, external process integration, and performance. A total of 30 completed surveys were received, representing a 73.2% response rate. A *t*-test of these paired samples resulted in no significant differences, indicating the responses from the key informants in the focal firms were objective and valid.

Table 2.  
Respondent profile

	Number of Respondents	Percentage
<b>Position</b>		
President (or General Manager)	65	21.4%
Vice President (or Vice General Manager)	113	37.2%
Director	89	29.3%
Manager	37	12.1%
<i>Total</i>	<i>304</i>	<i>100%</i>
<b>Years in Current Position</b>		
1 – 5	140	46.1%
5 – 10	82	27.0%
>10	52	17.1%
Unidentified	30	9.8%
<i>Total</i>	<i>304</i>	<i>100%</i>
<b>Years with Current Company</b>		
1 – 5	128	42.1%
5 – 10	90	29.6%
>10	52	17.1%
Unidentified	34	11.2%
<i>Total</i>	<i>304</i>	<i>100%</i>

## 5. Analysis

Prior to statistical analysis, a basic analysis of the collected data was conducted covering incorrect coding, item normality (skewness and kurtosis), means, standard deviations, and outliers, yielding acceptable results (Mentzer et al., 1999). The primary statistical tools used for analysis include SPSS and AMOS 5.0.

### 5.1. Measure assessment

The summary statistics and correlation matrix of the constructs are shown in Table 3. All correlations are statistically significant at the 0.01 level. Cronbach's alpha values were calculated and all values exceeded the suggested 0.7, demonstrating a high level of reliability (Nunnally, 1978). The constructs' reliability was further tested with the approach suggested by Fornell and Larcker (1981), which does not assume all loadings are the same. Again, all composite reliability values were well above the suggested 0.7 (Hair et al., 1998). In sum, the proposed constructs demonstrated a high level of internal consistency reliability.

Table 3.  
Constructs' summary statistics and Pearson correlations

	(1)	(2)	(3)	(4)	(5)	(6)	(7)
(1) Customer Orientation	1						
(2) Int Process Connectivity	0.521** <sup>a</sup>	1					
(3) Int Process Simplification	0.487**	0.440**	1				
(4) Ext Process Connectivity	0.557**	0.453**	0.510**	1			
(5) Ext Process Simplification	0.532**	0.450**	0.537**	0.719**	1		
(6) Service Innovative Capability	0.534**	0.404**	0.435**	0.611**	0.632**	1	
(7) Firm Performance	0.425**	0.326**	0.323**	0.573**	0.537**	0.600**	1
Mean	5.041	5.021	4.853	4.780	4.711	4.990	4.821
Standard Deviation	1.163	1.211	1.104	1.287	1.232	1.128	1.008
Cronbach's Alpha	0.856	0.887	0.828	0.914	0.886	0.893	0.867
Composite Reliability <sup>b</sup>	0.830	0.867	0.784	0.892	0.895	0.866	0.835
Average Variance Extracted <sup>b</sup>	0.549	0.612	0.494	0.682	0.623	0.636	0.577

<sup>a</sup> \*\* Correlation is significant at the 0.01 level.

<sup>b</sup> Composite Reliability and Average variance extracted (AVE) were calculated with the approaches suggested by Fornell and Larcker (1981).



A Confirmatory factor analysis (CFA) using maximum likelihood estimation (MLE) was conducted with AMOS 5.0 to assess and validate the operational constructs (Gerbing and Anderson, 1988). All latent variables were allowed to correlate with each other. The results of CFA measurement model are shown in Table 4. The traditional chi-square fit test indicates how well the model-implied covariance matrix matches the covariance among the measured variables in the sample data (Bollen, 1989). However, chi-square is sensitive to sample size – its value tends to be substantial when the sample is large (Jöreskog and Sörbom, 1993; Byrne, 2001). Therefore, other fit indices examined include chi-square/degree of freedom ratio (CMIN/DF), comparative fit index (CFI), and root mean square error of approximation (RMSEA). The relative chi-square value (CMIN/DF) of 1.712 falls into the recommended range of 3 to 1 (Carmines and McIver, 1981; Bollen and Long, 1993). Because CFI accounts for sample size, which is a common bias in index calculations, it has been argued to be the “index of choice” (Bentler, 1990; Byrne, 2001). The current model has a CFI value of 0.941, above the suggested 0.9 (Bentler, 1990). RMSEA has been recognized as one of the most informative criteria in covariance structure modeling because it takes into account the error of the approximation in the population and is sensitive to the number of estimated parameters in the model (Byrne, 2001). The RMSEA value of 0.048 is within the suggested range (less than 0.08) for good model fit (Browne and Cudeck, 1993). The above critical indices examined all demonstrate good fit between the measurement model and the data.

Other AMOS outputs of CFA were used to examine the constructs’ unidimensionality and validity. Standardized regression weights showed that all items

loaded on appropriate factors (constructs) as expected. All factor loadings exceeded 0.5, indicating content validity (Bollen, 1989). Critical ratio (CR) was obtained by dividing the estimate by its standard error. CR tests the null hypothesis that, in population, the regression coefficient is zero. All regression weights are significant at 0.05 level (CR > 1.96), supporting the unidimensionality and convergent validity of the constructs (Gerbing and Anderson, 1988). Discriminant validity was assessed by testing the chi-square difference between one- and two-factor models with respect to all pairs of measures (Anderson and Gerbing, 1988). Fig. 2 offers an example of chi-square comparison test between internal process connectivity and internal process simplification. All chi-square differences were significant ( $p < 0.001$ ), indicating the proposed measurement models have better fit with the data and supporting discriminant validity of the constructs. As an additional test, average variance extracted (AVE) was also calculated (see Table 3). AVE values of all the constructs exceeded the shared variances between each pair of the constructs, again supporting discriminant validity (Fornell and Larcker, 1981).

Table 4.  
CFA measurement model testing results

Path	Std. Weights	Critical Ratio	<i>p</i> -value
Int Process Connectivity ← Int Process Integration	0.692	(fixed)	
Int Process Simplification ← Int Process Integration	0.752	8.020	< 0.001
Ext Process Connectivity ← Ext Process Integration	0.873	(fixed)	
Ext Process Simplification ← Ext Process Integration	0.891	12.888	< 0.001
CO1 ← Customer Orientation	0.641	(fixed)	
CO2 ← Customer Orientation	0.776	11.045	< 0.001
CO3 ← Customer Orientation	0.748	10.831	< 0.001
CO4 ← Customer Orientation	0.795	11.219	< 0.001
CO5 ← Customer Orientation	0.734	10.578	< 0.001
IC1 ← Int Process Connectivity	0.759	(fixed)	
IC2 ← Int Process Connectivity	0.805	14.239	< 0.001
IC3 ← Int Process Connectivity	0.842	14.736	< 0.001
IC4 ← Int Process Connectivity	0.733	12.777	< 0.001
IC5 ← Int Process Connectivity	0.768	13.569	< 0.001

IS1 ← Int Process Simplification	0.759	(fixed)	
IS2 ← Int Process Simplification	0.626	10.496	< 0.001
S3 ← Int Process Simplification	0.663	10.815	< 0.001
IS4 ← Int Process Simplification	0.708	11.677	< 0.001
IS5 ← Int Process Simplification	0.749	12.223	< 0.001
EC1 ← Ext Process Connectivity	0.842	(fixed)	
EC2 ← Ext Process Connectivity	0.849	18.610	< 0.001
EC3 ← Ext Process Connectivity	0.856	18.631	< 0.001
EC4 ← Ext Process Connectivity	0.787	16.123	< 0.001
EC5 ← Ext Process Connectivity	0.792	16.221	< 0.001
ES1 ← Ext Process Simplification	0.852	(fixed)	
ES2 ← Ext Process Simplification	0.868	19.133	< 0.001
ES3 ← Ext Process Simplification	0.809	17.087	< 0.001
ES4 ← Ext Process Simplification	0.769	15.723	< 0.001
ES5 ← Ext Process Simplification	0.626	11.926	< 0.001
IN1 ← Service Innovative Capability	0.691	(fixed)	
IN2 ← Service Innovative Capability	0.802	12.859	< 0.001
IN3 ← Service Innovative Capability	0.800	12.703	< 0.001
IN4 ← Service Innovative Capability	0.848	13.257	< 0.001
IN5 ← Service Innovative Capability	0.837	13.229	< 0.001
PF1 ← Firm Performance	0.634	(fixed)	
PF2 ← Firm Performance	0.804	11.329	< 0.001
PF3 ← Firm Performance	0.825	11.394	< 0.001
PF4 ← Firm Performance	0.718	10.343	< 0.001
PF5 ← Firm Performance	0.799	11.384	< 0.001

Fit statistics: Chi-square = 934.993 ( $df = 546$ ,  $p < 0.001$ ), Chi-square/ $df$  (CMIN/DF) = 1.712, CFI = 0.941, RMSEA = 0.048

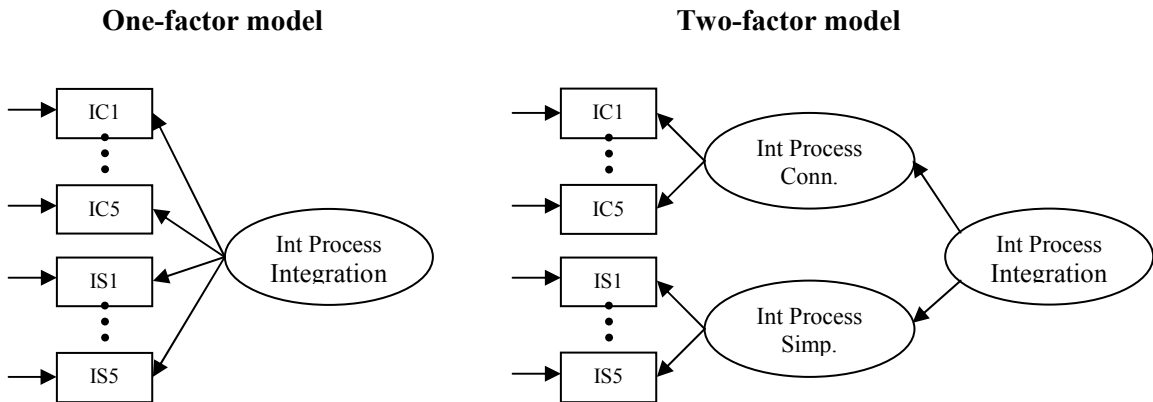

Fig. 2. Discriminant validity test example

In summary, these findings suggest that all the scales, including the newly developed measures, used to measure the model's factors are reliable and valid, and that an excellent fit exists between the measurement model and the data.

### 5.2. Structural model testing

Given the overall sound assessment of the measurement model, attention now turns to the structural model and testing of hypothesized relationships. AMOS 5.0 was used for the structural equation modeling (SEM) analysis. The structural model yields satisfactory key model fit indices with chi-square = 935.598 ( $df = 547$ ,  $p < 0.001$ ), chi-square/ $df$  (CMIN/DF) = 1.710, CFI = 0.941, and RMSEA = 0.048. AMOS outputs on paths' standardized regression weights with relevant critical ratios (CR) and  $p$ -values were then examined to test the hypotheses. Table 5 provides the results of the structural model tested.

Table 5.  
Structural model results

Path	Std. Weights	Critical Ratio	$p$ -value	Note
H1. Ext Process Integration $\leftarrow$ Int. Process Integration	0.815	3.992	< 0.001	Supported
H2. Int Process Integration $\leftarrow$ Customer Orientation	0.803	7.560	< 0.001	Supported
H3. Ext Process Integration $\leftarrow$ Customer Orientation	0.053	0.310	0.756	Rejected
H4 .Service Innovative Capability $\leftarrow$ Customer Orientation	0.182	1.487	0.137	Rejected
H5. Service Innovative Capability $\leftarrow$ Int Process Integration	-0.165	-0.688	0.492	Rejected
H6. Service Innovative Capability $\leftarrow$ Ext Process Integration	0.782	4.200	< 0.001	Supported
H7. Firm Performance $\leftarrow$ Service Innovative Capability	0.326	3.232	0.001	Supported
H8. Firm Performance $\leftarrow$ Int Process Integration	-0.183	-1.077	0.281	Rejected
H9. Firm Performance $\leftarrow$ Ext Process Integration	0.607	2.945	0.003	Supported

Fit statistics: Chi-square = 935.598 ( $df = 547$ ,  $p < 0.001$ ), Chi-square/ $df$  (CMIN/DF) = 1.710, CFI = 0.941, RMSEA = 0.048

H1 examines the relationship between a firm's internal process integration and external process integration and is supported with standardized regression weight = 0.815, CR = 3.992, and  $p < 0.001$ . In the current study, a firm's customer orientation was

found to have a positive impact on internal process integration (H2 is supported with standardized regression weight = 0.803, CR = 7.560, and  $p < 0.001$ ) but is not related to its external process integration (H3 is not supported with standardized regression weight = 0.053, CR = 0.310, and  $p = 0.756$ ). In contrast to past research results, a firm's customer orientation was not found to be related to its service innovative capability and H4 is not supported (standardized regression weight = 0.182, CR = 1.487, and  $p = 0.137$ ). The path between a firm's internal process integration and its service innovative capability (H5) is not supported (standardized regression weight = -0.165, CR = -0.688, and  $p = 0.492$ ). However, a firm's external process integration does have significant impact on its service innovative capability and H6 is supported with standardized regression weight = 0.782, CR = 4.200, and  $p < 0.001$ . Consistent with previous research on innovation, the relationship between a firm's service innovative capability and its firm performance (H7) is supported with standardized regression weight = 0.326, CR = 3.232, and  $p = 0.001$ . The direct path between internal process integration and firm performance (H8), previously suggested in the literature, is not supported in this study (standardized regression weight = -0.183, CR = -1.077, and  $p = 0.281$ ). On the other hand, a firm's external process integration has direct impact on its firm performance and H9 is supported with standardized regression weight = 0.607, CR = 2.945, and  $p = 0.003$ ).

## **6. Discussion and implications**

The current study makes several contributions that have important implications for both researchers and managers. First, a simple but generalizable conceptualization was developed for supply chain process integration. The new scale items passed rigorous

statistical tests and demonstrated a high level of reliability and validity. This definition and operationalization can be easily modified to study integration in different situations in future research. Managers can also benefit from the conceptualization by focusing on the two aspects – connectivity and simplification – in their process integration practices.

All proposed links were based on existing literature and, individually, had been supported by past research. However, the current study takes a holistic approach by combining major constructs in marketing, OM, and SCM literature in a single model with interesting findings.

The sequential relationship between internal process integration and external process integration (H1) was confirmed. This is in line with Stevens' (1989) argument that internal integration precedes external integration. The implication for managers is that before integrating externally with other partners, a firm should prepare by integrating internal processes and functional areas (Lambert et al., 1998; Min and Menzter, 2004). This important path also helps to explain some of the unsupported paths in the analysis.

Although the supported path between customer orientation and internal process integration (H2) is consistent with existing literature (e.g. Webster, 1988; Narver and Slater, 1990), the expected direct impact of customer orientation on external process integration (H3) was not supported. This is seemingly surprising because one could expect a firm to be more externally integrated with its partners to have information available and respond to customer requirements. Taking H1 and H2 into consideration helps provide an explanation: the lack of direct link between customer orientation and external process integration is due to the necessary sequencing between internal process

integration and external process integration. In other words, customer orientation can enhance a firm's external process integration, but the firm needs to have internal integration first. This is in line with Min et al.'s (2007) argument that without coordinated activities and processes within each firm, it is difficult to perform managerial tasks across firms within the supply chain in a collective manner.

Han et al. (1998) identified innovation as an important missing link between customer orientation and firm performance and suggested that the investigation of other factors is needed. As an extension of their research, the current study included supply chain process integration constructs in the conceptual model. The direct impact of customer orientation on innovation as found by Han et al. (1998) was not supported (H4). This result signals the critical importance of supply chain process integration to developing a high level of innovative capability in a supply chain context. In order to be more capable in creating new services, a firm needs to be highly integrated both internally and externally (internal precedes external). The reason is that service innovations (such as logistics service innovations) require knowledge and inputs from different functional areas within a firm and across firms (Flint et al., 2005), which are facilitated by the close interactions in supply chain process integration.

Although it is proposed that both internal process integration (H5) and external process integration (H6) have direct impacts on a firm's service innovative capability, H5 was not supported. This may be explained by two reasons. First, the focus here is a firm's service innovative capability. In order to provide innovative customer services, an external orientation is fundamental (c.f. Min and Mentzer, 2004). It can be expected that a high level of service innovative capability is not likely to be achieved with only an

internal perspective and internal process integration. Second, this result does not indicate that internal process integration is not important. Instead, as H1 suggested, internal process integration is a pre-requisite for external process integration to have impact on a firm's service innovative capability (i.e. an indirect impact of internal process integration on service innovative capability).

The direct impact of internal process integration on firm performance was not supported (H8). However, this may be explained by Christopher's (2005) argument that competition takes place between supply chains rather than between individual firms. It is not enough simply to optimize internal structures and infrastructures through internal process integration. This is consistent with Frohlich and Westbrook's (2001) finding that the most successful manufacturers seem to be those that have carefully linked their internal processes to external suppliers and customers in unique supply chains, while inward-facing (i.e. minimum external process integration) manufacturers recorded the lowest performance. The support for both H7 and H9 indicates that the relationship between a firm's external process integration and its firm performance is partially mediated by its supply chain innovative capability. This shows that, although a firm may achieve better performance through external process integration or other capabilities, supply chain innovative capability plays a critical role in contributing to firm performance. Vickery et al.'s (2003) empirical study found that the relationship between supply chain integration and a firm's financial performance is fully mediated by customer service. Results of the current study further suggest that in today's environment, firms need to develop a high level of service innovative capability in order to gain competitive advantages.



In sum, the findings of this study do not contradict past research. Instead, this study makes an important contribution to the understanding of supply chain process integration by including more variables. In a SCM context, researchers and managers can benefit from the confirmed sequential order between internal process integration and external integration. Although a firm may embrace supply chain integration for various reasons, maintaining a strong customer orientation can significantly enhance a firm's supply chain process integration – with direct impact on internal process integration and indirect impact on external process integration. Also, as Flint et al. (2005) predicted, service innovation is crucial in today's competition. Innovativeness requires supply chain process integration support.

## **7. Limitations**

Due to the exploratory nature of the study and resource constraints, some limitations need to be acknowledged. First, as the results of this study show, there is a sequencing between the supply chain process integration constructs: a firm needs to be internally integrated before achieving external process integration. The sequential order implies that a longitudinal research design may better fit the research objective. Longitudinal data will help to achieve more meaningful results by capturing the dynamics involved in the implementation of supply chain process integration, which can help managers make sound decisions.

Second, as a response to Pagell's (2004) call for research on the antecedents and consequences of integration, the current study identified one key driver (customer orientation) and one key outcome (service innovative capability) of supply chain process integration. While customer orientation was demonstrated as critical, a firm is likely to

have other business orientations as well. Therefore, future research should explore the impacts of other business orientations on integration and the interaction among different orientations. Also, although this study shows that service innovative capability plays a critical role in enhancing firm performance as an outcome of supply chain process integration, future research may examine the role of other important capabilities in the integration-performance relationship.

Third, although extensive efforts were taken to ensure the validity of the responses from the key informants, there is still room to improve the rigorousness of the study. Supply chain process integration involves different parties both internally and externally, and managers from different areas within a firm or from different partnering firms (such as suppliers and customers) may have different perceptions of their process integration practices. Therefore, dyadic or triadic data collected from different parties may generate more meaningful results by comparing and contrasting the responses from various parties.

## REFERENCES

- Alder, P.S., 1995. Interdepartmental interdependence and coordination: the case of the design/manufacturing interface. *Organization Science* 6 (2), 147-167.
- Amabile, T.M., Conti, R., Coon, H., Lazenby, J., Herron, M., 1996. Assessing the work environment for creativity. *Academy of Management Journal* 39 (5), 1154-1184.
- Anderson, J.C., Gerbing, D.W., 1988. Structural equation modeling in practice: a review and recommended two-step approach. *Psychological Bulletin* 103, 411-423.
- Anderson, M.G., Katz, P.B., 1998. Strategic sourcing. *International Journal of Logistics Management* 9 (1), 1-13.
- Argyris, C., 1982. *Reasoning, Learning, and Action: Individual and Organizational*, Jossey-Bass, San Francisco, CA.
- Armstrong, J.S., Overton, T.S., 1977. Estimating nonresponse bias in mail surveys. *Journal of Marketing Research* 14 (3), 396-402.
- Atuahene-Gima, K., Evangelista, F., 2000. Cross-functional influence in new product development: an exploratory study of marketing and R&D perspectives. *Management Science* 46 (10), 1267-1284.
- Barney, J., 1991. Firm resources and sustained competitive advantage. *Journal of Management* 17 (1), 99-120.
- Barratt, M., Oliveira, A., 2001. Exploring the experiences of collaborative planning initiatives. *International Journal of Physical Distribution & Logistics Management* 31 (4), 266-289.
- Batenburg, R., Rutten, R., 2003. Managing innovation in regional supply networks: a Dutch case of "knowledge industry clustering". *Supply Chain Management: An International Journal* 8 (3), 263-270.
- Bentler, P.M., 1990. Fit indexes, Lagrange multipliers, constraint changes, and incomplete data in structural models. *Multivariate Behavioral Research* 25 (1), 163-72.
- Berry, L.L., Shankar, V., Parish, J.T., Cadwallader, S., Dotzel, T., 2006. Creating new markets through service innovation. *MIT Sloan Management Review* 47 (2), 56-63.
- Berthon, P., Hulbert, J.M., Pitt, L.F., 1999. To serve or create? Strategic orientations toward customers and innovation. *California Management Review* 42 (1), 37-58.
- Best, W.J., Seger, R.E., 1989. Distribution synergies: easy to see, harder to get. *Mergers and Acquisitions* 24 (2), 48-53.

- Birou, L.M., Fawcett, S.E., Magnan, G.M., 1998. The product life cycle: a tool for functional strategic alignment. *International Journal of Purchasing and Materials Management* 34 (2), 37-51.
- Bishop, S.K., 1999. Cross-functional project teams in functionally aligned organizations. *Project Management Journal* 30 (3), 6-12.
- Bollen, K.A., 1989. *Structural Equations with Latent Variables*, Wiley, New York, NY.
- Bollen, K.A., Long, J.S., 1993. Introduction. In Bollen, K.A., Long, J.S. (Eds.), *Testing Structural Equation Models*, Sage Publications, Newbury, CA, 1-9.
- Boyer, K.K., Olson, J.R., Calantone, R.J., Jackson, E.C., 2002. Print versus electronic surveys: a comparison of two data collection methodologies. *Journal of Operations Management* 20, 357-373.
- Bowersox, D.J., Closs, D.L., Stank, T.P., 1999. *21st Century Logistics: Making Supply Chain Integration a Reality*. Council of Logistics Management, Oak Brook, IL.
- Browne, M.W., Cudeck, R., 1993. Alternative ways of assessing model fit. In Bollen, K.A., Long, J.S. (Eds.), *Testing Structural Equation Models*, Sage Publications, Newbury Park, CA, 136-162.
- Byrne, B.M., 2001. *Structural Equation Modeling with AMOS: Basic Concepts, Applications, and Programming*, Lawrence Erlbaum Associates Publishers, Mahwah, NJ.
- Campbell, D.T., 1955. The informant in quantitative research. *American Journal of Sociology* 60 (1), 339-342.
- Calantone, R., Dröge, C., Vickery, S., 2002. Investigating the manufacturing-marketing interface in new product development: does context affect the strength of relationships? *Journal of Operations Management* 20 (3), 273-287.
- Carmines, E.G., McIver, J.P., 1981. Analyzing models with unobserved variables. In Bohrnstedt, G.W., Borgatta, E.F. (Eds.), *Social Measurement: Current Issues*, Sage Publications, Beverly Hills, CA.
- Chandler, A.D., 1962, *Strategy and Structure*, MIT Press, Cambridge, MA.
- Chen, I.J., Paulraj, A., Towards a theory of supply chain management: the constructs and measurements. *Journal of Operations Management* 22, 119-150.
- Christopher, M.L., 2005. *Logistics and Supply Chain Management*, 3<sup>rd</sup> Edition, Prentice Hall, London, UK.

- Churchill, G.A., 1979. A paradigm for developing better measures of marketing. *Journal of Marketing Research* 16 (1), 64-73.
- Clark, K.B., Wheelwright, S.C., 1992. Organizing and leading heavyweight development teams. *California Management Review* 34 (3), 9-28.
- Claycomb, C., Dröge, C., Germain, R., 1999. The effect of just-in-time with customers on organizational design and performance. *International Journal of Logistics Management* 10 (1), 37-58.
- Connor, T., 1999. Customer-led and market-oriented: a matter of balance. *Strategic Management Journal* 20 (December), 1157-1163.
- Das, A., Narasimhan, R., Talluri, S., 2006. Supplier integration—finding an optimal configuration. *Journal of Operations Management* 24, 563-582.
- Das, S.R., Joshi, M.P., 2007. Process innovativeness in technology services organizations: roles of differentiation strategy, operational autonomy and risk-taking propensity. *Journal of Operations Management* 25, 643-660.
- Daugherty, P.J., Sabath, R.E., Rogers, D.S., 1992. Competitive advantage through customer responsiveness. *Logistics and Transportation Review* 28 (3), 257-271.
- Daugherty, P.J., Ellinger, A.E., Gustin, C.M., 1996. Integrated logistics: achieving logistics performance improvements. *Supply Chain Management: An International Journal* 1 (3), 25-33.
- Daugherty, P.J., Germain, R., Dröge, C., 1995. Predicting EDI technology adoption in logistics management: the influence of context and structure. *Logistics and Transportation Review* 31 (4), 309-324.
- Daugherty, P.J., Stank, T.P., Ellinger, A.E., 1998. Leveraging logistics/distribution capabilities: the effect of logistics service on market share. *Journal of Business Logistics* 19 (2), 35-51.
- Day, G.S., 1994. The capabilities of market-driven organizations. *Journal of Marketing* 58 (4), 37-52.
- Deshpande, R., Farley, J.U., Webster, F.E., Jr., 1993. Corporate culture, customer orientation, and innovativeness. *Journal of Marketing* 57(1), 23-37.
- Deshpande, R., Farley, J.U., 1998. Measuring market orientation: generalization and synthesis. *Journal of Market-Focused Management* 2, 213-232.

- Dess, G.G., Robinson, R.B., 1984. Measuring organizational performance in the absence of objective measures: the case of the privately-held firms and conglomerate business unit. *Strategic Management Journal* 5, 265-273.
- Dröge, C., Jayaram, J., Vickery, S.K., 2004. The effects of internal versus external integration practices on time-based performance and overall firm performance. *Journal of Operations Management* 22, 557-573.
- Drucker, Peter F., 1954. *The Practice of Management*, Harper and Row Publishers, Inc., New York, NY.
- Ellinger, A.E., Taylor, J.C., Daugherty, P.J., 1999. Automatic replenishment programs and level of involvement: performance implications. *International Journal of Logistics Management* 10 (1), 25-36.
- Ellinger, A.E., Daugherty, P.J., Keller, S.B., 2000. The relationship between marketing/logistics interdepartmental integration and performance in U.S. manufacturing firms: an empirical study. *Journal of Business Logistics* 21 (1), 1-21.
- Ettlie, J.E., Reza, E.M., 1992. Organizational integration and process innovation. *Academy of Management Journal* 35 (4), 795-827.
- Ettlie, J.E., Stoll, H.W., 1990. *Managing the Design-Manufacturing Process*. McGraw-Hill, New York.
- European Commission, 1996. *RITTS and RIS Guidebook: Regional Actions for Innovation*, European Commission, Brussels, Belgium.
- Felton, A.P., 1959. Making the marketing concept work. *Harvard Business Review* 37 (4), 55-65.
- Flint, D.J., Larsson, E., Gammelgaard, B., Mentzer, J.T., 2005. Logistics innovation: a customer value-oriented social process. *Journal of Business Logistics* 26 (1), 113-147.
- Fornell, C., Larcker, D.F., 1981. Evaluating structural equation models with unobservable variables and measurement error. *Journal of Marketing Research* 18 (1), 39-50.
- Friedman, T.L., 2005. *The World Is Flat: A Brief History of the Twenty-first Century*, Farrar, Straus and Giroux, New York.
- Frohlich, M.T., Westbrook, R., 2001. Arcs of integration: an international study of supply chain strategies. *Journal of Operations Management* 19, 185-200.
- Galbraith, J.R., Kazanjian, R.K., 1986. *Strategy Implementation: Structure, System, and Process*, West Publishing Company, St Paul, MN.

- Galbraith, J.R., Nathanson, D.A., 1978. *Strategy Implementation: The Role of Structure and Process*, West Publishing Company, St Paul, MN.
- Galunic, D.C., Eisenhardt, K.M., 1994. Renewing the strategy-structure-performance paradigm. *Research in Organizational Behavior* 16, 215-255.
- Gatignon, H., Xuereb, J.-M., 1997. Strategic orientation of the firm and new product performance. *Journal of Marketing Research* 34 (1), 77-90.
- Gerbing, D.W., Anderson, J.C., 1988. An updated paradigm for scale development incorporating unidimensionality and its assessment. *Journal of Marketing Research* 25 (2), 186-192.
- Germain, R., Dröge, C., Daugherty, P.J., 1994. The effects of just-in-time selling on organizational structure: an empirical investigation. *Journal of Marketing Research* 31 (4), 471-483.
- Germain, R., Iyer, K.N.S., 2006. The interaction of internal and downstream integration and its association with performance. *Journal of Business Logistics* 27 (2), 29-44.
- Gerwin, D., 1993. Integrating manufacturing into the strategic phases of new product development. *California Management Review* 35, 123-137.
- Gimenez, C., 2006. Logistics integration processes in the food industry. *International Journal of Physical Distribution & Logistics Management* 36 (3), 231-249.
- Gimenez, C., Ventura, E., 2003. Supply chain management as a competitive advantage in the Spanish grocery sector. *International Journal of Logistics Management* 14 (1), 77-88.
- Gimenez, C., Ventura, E., 2005. Logistics-production, logistics-marketing and external integration: their impact on performance. *International Journal of Operations & Production Management* 25 (1), 20-38.
- Grant, R.M., 1991. The resource-based theory of competitive advantage: implications for strategy formulation. *California Management Review* 33, 114-135.
- Grant, R.M., 1996. Prospering in dynamically-competitive environments: organizational knowledge as knowledge integration. *Organization Science* 7 (4), 375-387.
- Grinyer, P.H., Yasai-Ardekani, M., Al-Bazzaz, S., 1980. Strategy, structure, the environment, and financial performance in 48 United Kingdom companies. *Academy of Management Journal* 23 (2), 193-220.

- Gupta, A.K., Raj, S.P., Wilemon, D.A., 1986. Model for studying R&D-marketing interface in the product innovation process. *Journal of Marketing* 50 (2), 7-17.
- Gustin, C.M, Stank, T.P., Daugherty, P.J., 1994. Computerization: supporting integration. *International Journal of Physical Distribution & Logistics Management* 24 (1), 11-16.
- Habib, M.M., Victor, B., 1991. Strategy, structure, and performance of U.S. manufacturing and service MNCs: a comparative analysis. *Strategic Management Journal* 12 (8), 589-606.
- Hage, J., 1980. *Theories of Organization: Form, Process and Transformation*. John Wiley & Sons, New York, NY.
- Hair, J.F., Anderson, R.E., Tatham, R.L., Black, W.C., 1998. *Multivariate Data Analysis*, 5<sup>th</sup> Ed., Prentice Hall, Upper Saddle River, NJ.
- Hall, D.J., Saias, M.A., 1980. Strategy follows structure! *Strategic Management Journal* 1 (2), 149-163.
- Hall, R.W., 1987. *Attaining Manufacturing Excellence*. Dow Jones-Irwin, Homewood, IL.
- Han, J.K., Kim, N., Srivastava, R.K., 1998. Market orientation and organization performance: is innovation a missing link? *Journal of Marketing* 62 (4), 30-45.
- Handfield, R.B., Nichols, E.L., 1999. *Introduction to Supply Chain Management*. Prentice-Hall, Upper Saddle River, NJ.
- Handfield, R.B., Ragatz, G.L., Petersen, K.P., Monczka, R.M., 1999. Involving suppliers in new product development. *California Management Review* 42 (1), 59-81.
- Heeler, R.M., Ray, M.L., 1972. Measure validation in marketing. *Journal of Marketing Research* 9 (4), 361-70.
- Hitt, M.A., Nixon, R.D., Hoskisson, R.E., Kochhar, R., 1999. Corporate entrepreneurship and cross-functional fertilization: activation, process and disintegration of a new product design team. *Entrepreneurship Theory and Practice* 23 (3), 145-167.
- Hurley, R.F., Hult, G.T.M., 1998. Innovation, market orientation, and organizational learning: an integration and empirical examination. *Journal of Marketing* 62 (3), 42-54.
- Jana, R., 2007. Inshort: innovative services – not just gadgets. *Business Week* 4038 (June 11, 2007), IN 5.



- Jaworski, B.J., Kohli, A.K., 1993. Market orientation: antecedents and consequences. *Journal of Marketing* 57 (3), 53-70.
- Jaworski, B.J., Kohli, A.K., 1996. Market orientation: reviews, refinement, and roadmap. *Journal of Market Focused Management* 1 (2), 119-135.
- Johnson, J.L., 1999. Strategic integration in distribution channels: managing the interfirm relationship as strategic asset. *Journal of Academy of Marketing science* 27 (1), 4-18.
- Jöreskog, K.G., Sörbom, D., 1993. LISREL-8: Structural Equation Modeling with the SIMPLIS Command Language, Scientific Software International, Chicago, IL.
- Ketokivi, M.A., Schroeder, R.G., 2004. Perceptual measures of performance: fact or fiction? *Journal of Operations Management* 22, 247-264.
- Khazanchi, S., Lewis, M.W., Boyer, K.K., 2007. Innovation-supportive culture: the impact of organizational values on process innovation. *Journal of Operations Management* 25, 871-884.
- Kofteros, X.A., Vonderembse, M.A., Doll, W.J., 2001. Concurrent engineering and its consequences. *Journal of Operations Management* 19 (1), 97-115.
- Kogut, B., Zander, U., 1992. Knowledge of the firm, combinative capabilities and the replication of technology. *Organization Science* 3 (3), 383-397.
- Kohli, A.K., Jaworski, B.J., 1990. Market orientation: the construct, research propositions, and managerial implications. *Journal of Marketing* 54 (2), 1-18.
- Kusunoki, K., Namagami, T., 1998. Interfunctional transfers of engineers in Japan: empirical findings and implications for cross-functional integration. *IEEE Transaction on Engineering Management* 45 (3), 250-262.
- Lambert, D.M., 2004. *Supply Chain Management: Processes, Partnerships, Performance*. Supply Chain Management Institute, Sarasota, FL.
- Lambert, D.M., Cooper, M.C., Pagh, J.D., 1998. Supply chain management: implementation issues and research opportunities. *International Journal of Logistics Management* 9 (2), 1-19.
- Lambert, D.M., García-Dastugue, S.J., Croxton, K.L., 2005. An evaluation of process-oriented supply chain management frameworks. *Journal of Business Logistics* (26) 1, 25-51.
- Lawton, L., Parasuraman, A., 1980. The impact of the marketing concept on new product planning. *Journal of Marketing* 44 (1), 19-25.

- Lee, H.L., Tang, C.S., 1998. Variability reduction through operations reversal. *Management Science* 44 (2), 162-172.
- Lohr, S.L., 1999. *Sampling: Design and Analysis*, Duxbury Press, Pacific Grove, CA.
- Lumpkin, G.T., Dess, G.G., 1996. Clarifying the entrepreneurial orientation construct and linking it to performance. *Academy of Management Review* 21, 135-172.
- Maloni, M., Benton, W.C., 2000. Power influences in the supply chain. *Journal of Business Logistics* 21 (1), 49-63.
- Mentzer, J.T., Flint, D.J., 1997. Validity in logistics research. *Journal of Business Logistics* 18 (1), 199-216.
- Mentzer, J.T., Flint, D.J., Kent, J.L., 1999. Developing logistics service quality scale. *Journal of Business Logistics* 20 (1), 9-32.
- Metters, R., 1997. Quantifying the bullwhip effect in supply chains. *Journal of Operations Management* 15, 89-100.
- Miles, R.E., Snow, C.C., 1978. *Organizational Strategy, Structure, and Process*, McGraw-Hill, New York, NY.
- Miles, R.E., Snow, C.C., 1984. Fit, failure and the Hall of Fame. *California Management Review* 26 (3), 10-28.
- Min, S., Mentzer, J.T., 2004. Developing and measuring supply chain management concepts. *Journal of Business Logistics* 25 (1), 63-99.
- Min, S., Mentzer, J.T., Ladd, R.T., 2007. A market orientation in supply chain management. *Journal of Academy of Marketing Science*, forthcoming.
- Mintzberg, H., Dougherty, D., Jorgensen, J., Westley, F., 1996. Some surprising things about collaboration – knowing how people connect makes it work better. *Organizational Dynamics*, 25 (1), 30-71.
- Narasimhan, R., Das, A., 1998. Causal linkages in supply chain management: an exploratory study of North American manufacturing firms. *Decision Science* 29 (3), 579-605.
- Narasimhan, R., Jayaram, J. 1998. Causal linkages in supply chain management: An exploratory study of North American manufacturing firms. *Decision Sciences* 29 (3), 579-605.

Narver, J.C., Slater, S.F., 1990. The effect of a market orientation on business profitability. *Journal of Marketing* 54 (4), 20-35.

Nunnally, J.C., 1978. *Psychometric Theory*, 2<sup>nd</sup> Ed., McGraw-Hill, Inc., New York, NY.

O'Leary-Kelly, S.W., Flores, B.E., 2002. The integration of manufacturing and marketing/sales decisions: impact on organizational performance. *Journal of Operations management* 20 (3), 221-240.

Olson, E.M., Walker, O.C., Ruekert, R.W., 1995. Organizing for new product development: the moderating role of product innovativeness. *Journal of Marketing* 59 (1), 48-62.

Olson, E.M., Walker, O.C., Ruekert, R.W., Bonner, J.M., 2001. Patterns of cooperation during new product development among marketing, operations and R&D: implications for project performance. *Journal of Product Innovation Management* 18 (4), 258-271.

Pagell, M., 2004. Understanding the factors that enable and inhibit the integration of operations, purchasing and logistics. *Journal of Operations Management* 22 (5), 459-487.

Paulraj, A., Chen, I.J., 2007. Strategic buyer-supplier relationships, information technology and external logistics integration. *Journal of Supply Chain Management* 43 (2), 2-14.

Peteraf, M.A., 1993. The cornerstones of competitive advantage: a resource-based view. *Strategic Management Journal* 14 (3), 179-191.

Pierce, J.L., Delbecq, A.L., 1977. Organizational structure, individual attitudes, and innovation. *Academy of Management Review* 2 (1), 26-37.

Porter, M.E., 1980. *Competitive Strategy: Techniques for Analyzing Industries and Competitors*. The Free Press, New York, NY.

Porter, M.E., 1985. *Competitive Advantage: Creating and Sustaining Superior Performance*. The Free Press, New York, NY.

Prahalad, C.K., Hamel, G., 1990. The core competence of the corporation. *Harvard Business Review*, 68 (3), 79-91.

Rodrigues, A.M., Stank, T.P., Lynch, D.F., 2004. Linking strategy, structure, process and performance in integrated logistics. *Journal of Business Logistics* 25 (2), 65-94.

Rosenzweig, E.D., Roth, A.V., Dean, J.W., Jr., 2003. The influence of an integration strategy on competitive capabilities and business performance: an exploratory study of consumer manufacturers. *Journal of Operations Management* 21, 437-456.

- Roy, S., Sivakumar, K., Wilkinson, I.F., 2004. Innovation generation in supply chain relationships: a conceptual model and research propositions. *Journal of Academy of Marketing Science* 32 (1), 61-79.
- Ruekert, R.W., Walker, O.C., 1987. Marketing's interaction with other functional units: a conceptual framework and empirical evidence. *Journal of Marketing* 51 (1), 1-19.
- Schmenner, R.W., Swink, M.L., 1998. On theory in operations management. *Journal of Operations Management* 17 (1), 97-113.
- Smith, P.G., Reinertsen, D.G., 1998. *Developing Products in Half the Time: New Rules, New Tools*. Wiley & Sons, NY.
- Song, M., Xie, J., 2000. Does innovativeness moderate the relationship between cross-functional integration and product performance? *Journal of International Marketing* 8 (4), 61-89.
- Song, X., Thieme, R.J., Xie, J., 1998. Patterns of cross-functional joint involvement across product development stages: an exploratory study. *Journal of Product Innovation Management* 15 (4), 289-303.
- Sousa, R., Linking quality management to manufacturing strategy: an empirical investigation of customer focus practices. *Journal of Operations Management* 21, 1-18.
- Stank, T.P., Keller, S.B., Closs, D.J., 2001. Performance benefits of supply chain logistical integration. *Transportation Journal* 41 (2/3), 32-46.
- Stank, T.P., Daugherty, P.J., Ellinger, A.E., 1999. Marketing/logistics integration and firm performance. *International Journal of Logistics Management* 10(1), 11-24.
- Stevens, G.C., 1989. Integrating the supply chain. *International Journal of Physical Distribution & Materials Management* 19 (8), 3-8.
- Stock, G.N., Greis, N.P., Kasarda, J.D., 1998. Logistics, strategy and structure: a conceptual framework. *International Journal of Operations & Production Management* 18 (1), 37-52.
- Sutton, M.J., 1997. The role of Electronic Data Interchange in the transportation industry: Part 1. *Defense Transportation Journal* 53 (4), 10-12.
- Swink, M., 1999. Threats to new product manufacturability and the effects of development team integration processes. *Journal of Operations Management* 17 (6), 691-709.

- Swink, M., Nair, A., 2007. Capturing the competitive advantages of AMT: design-manufacturing integration as a complementary asset. *Journal of Operations Management* 25, 736-754.
- Swink, M., Narasimhan, R., Wang, C., 2007. Managing beyond the factory walls: effects of four types strategic integration on manufacturing plant performance. *Journal of Operations Management* 25, 148-164.
- Swink, M., Song, M., 2007. Effects of marketing-manufacturing integration on new product development time and competitive advantage. *Journal of Operations Management* 25, 203-217.
- Swink, M., Talluri, S., Pandejpong, T., 2006. Faster, better, cheaper: A study of NPD project efficiency and performance tradeoffs. *Journal of Operations Management* 24, 542-562.
- Tan, C.L., Vonderembse, M.A., 2006. Mediating effects of computer-aided design usage: from concurrent engineering to product development performance. *Journal of Operations Management* 24, 494-510.
- Tan, K.C., Kannan, V.R., Handfield, R.B., 1998. Supply chain management: supplier performance and firm performance. *International Journal of Purchasing and Materials Management* 34 (3), 2-9.
- Thompson, J.D., 1967. *Organizations in Action*, McGraw Hill, New York, NY.
- Thompson, V.A., 1965. Bureaucracy and innovation. *Administrative Science Quarterly* 5, 1-20.
- Verma, R., Thompson, G.M., Moore, W.L., Louviere, J.J., 2001. Effective design of product/services: an approach based on integration of marketing and operations management decisions. *Decision Sciences* 31 (1), 165-193.
- Vickery, S.K., Jayaram, J., Dröge, C, Calantone, R., 2003. The effects of an integrative supply chain strategy on customer service and financial performance: an analysis of direct versus indirect relationships. *Journal of Operations Management* 21, 523-539.
- Wagner, S.M., 2003. Intensity and managerial scope of supplier integration. *Journal of Supply Chain Management* 39 (4), 4-15.
- Webster, F.E., Jr., 1988. Rediscovering the marketing concept. *Business Horizons* 31 (3), 29-39.
- Wernerfelt, B., 1984. A resource-based view of the firm. *Strategic Management Journal* 5 (2), 171-180.

Wind, Y., Robertson, T.S., 1983. marketing strategy: new directions for theory and research. *Journal of Marketing* 47 (2), 12-25.

Zaltman, G., Duncan, R., Holbel, J., 1973. *Innovations and Organizations*, John Wiley & Sons, New York, NY.

**APPENDIX. CONSTRUCTS AND SCALE ITEMS**  
(mean and standard deviation are given in the parentheses)

*Customer orientation*

(7-point Likert-type scale where 1 = Strongly Disagree and 7 = Strongly Agree)

CO1. We are more customer-focused than our competitors. (4.67, 1.51)

CO2. Our business objectives are driven primarily by customer satisfaction. (4.84, 1.45)

CO3. We communicate information about our customer experiences across all business functions. (5.28, 1.50)

CO4. Our strategy for gaining a competitive advantage is based on our understanding of customer needs. (5.23, 1.39)

CO5. We measure customer satisfaction frequently. (5.18, 1.46)

*Internal Process Integration*

*- Internal Process Connectivity*

(7-point Likert-type scale where 1 = Strongly Disagree and 7 = Strongly Agree)

Our firm

IC1. ...designates people with particular skills to coordinate various internal processes. (4.79, 1.52)

IC2. ...develops a common goal to align the efforts of all processes, in addition to setting specific objectives for each process. (5.14, 1.47)

IC3. ...ensures compatibility among all relevant internal processes. (5.07, 1.45)

IC4. ...uses common standards for all internal processes so that processes can be linked smoothly. (4.91, 1.43)

IC5. ...communicates information in a timely manner about specific internal processes to facilitate other related processes. (5.18, 1.44)

*- Internal Process Simplification*

(7-point Likert-type scale where 1 = Strongly Disagree and 7 = Strongly Agree)

Our firm

IS1. ...reduces operational complexity. (4.92, 1.40)

IS2. ...simplifies product design to reduce process complexity without sacrificing product functionality. (4.98, 1.35)

IS3. ...regularly evaluates whether there are redundant activities within internal processes. (4.82, 1.35)

IS4. ...reduces unnecessary steps within internal processes. (4.74, 1.50)

IS5. ...reduces the need for employees in different areas to perform identical job tasks. (4.80, 1.55)

*External Process Integration*

*- External Process Connectivity*

(7-point Likert-type scale where 1 = Strongly Disagree and 7 = Strongly Agree)

Our firm along with our major partners

EC1. ...discuss processes across our business operations when we conduct strategic planning. (4.68, 1.49)

EC2. ...try to develop common goals to align process efforts. (4.81, 1.49)

EC3. ...ensure compatibility between related processes of different firms. (4.70, 1.54)

- EC4. ...use common standards to link processes smoothly across firms. (4.69, 1.45)  
EC5. ...share information in a timely manner to facilitate cross-organizational processes.  
(5.01, 1.49)

*- External Process Simplification*

(7-point Likert-type scale where 1 = Strongly Disagree and 7 = Strongly Agree)

Our firm along with our major partners

- ES1. ...work together to redesign work routines and processes for the purpose of simplicity. (4.70, 1.48)  
ES2. ...work together to reduce operational complexity. (4.68, 1.50)  
ES3. ...focus on reducing channel complexity. (4.88, 1.44)  
ES4. ...regularly evaluate whether there are redundant activities within various processes across firms. (4.58, 1.46)  
ES5. ...reduce/eliminate source inspection, receiving inspection, and count verification through our firm's supplier certification program. (4.71, 1.55)

*Service innovative capability*

(7-point Likert-type scale where 1 = Strongly Disagree and 7 = Strongly Agree)

- IN1. Innovation is readily accepted in our firm's management in various areas. (4.73, 1.44)  
IN2. Our firm's top management gives special emphasis to service innovation. (4.89, 1.35)  
IN3. Our firm constantly seeks new ways to better service our customers. (5.22, 1.29)  
IN4. Our firm is able to change or modify our current service approaches to meet special requirements from customers. (5.10, 1.27)  
IN5. Compared to our competition, our firm is able to come up with new service offerings. (5.01, 1.36)

*Firm performance*

Our firm's financial and market performance in the last year comparing to major competitors in the following areas.

(7-point Likert-type scale where 1 = Much Worse, 4 = About the Same, and 7 = Much Better)

- PF1. Sales volume (4.84, 1.31)  
PF2. Profit margin (4.61, 1.36)  
PF3. Return on investment (ROI) (4.76, 1.29)  
PF4. Customer satisfaction (5.03, 1.07)  
PF5. Overall competitive position (4.87, 1.18)