



Selecting Tornado Shelters

George W. A. Mahoney
Associate Professor Agricultural Engineering

Raymond L. Huhnke
Extension Agricultural Engineer Agricultural Engineering

"If you know a better 'ole, go to it!" This famous saying of Old Bill, a British cartoon character of World War I and II, is appropriate advice for Oklahomans in tornado season. Even better advice would be to build a "better hole" where to use in storms. To be effective, a shelter has to be conveniently located and adequately strong.

Storm shelters don't have to be damp holes in the ground. With planning, shelters can be livable and stocked with necessities for long periods of stay. A better hole may have lights, electric outlets for a TV or radio, games for children, food, beverages, and a place for youngsters to sleep while waiting out the storm.

Planning

Three decisions should be made before looking for shelter plans or hiring an engineer to design the shelter: size, function, and location. Will it be strictly a shelter from storms? If so, a 4 by 8 foot structure would accommodate several adults and older children up to an hour waiting for the storm to pass. A shelter this size would not provide space for more than four people to sit or lie down.

Small shelters must never be used for storage! If a portion of the shelter will be used as a storage or as an office, consider building a unit at least 8 feet by 8 feet in size allowing about 10 square feet per person. If carefully planned, this size would provide storage space for many items and still leave room for an average family of five.

Installing shelving along one wall adds storage space and room for a TV set or radio for weather reports. Foldaway bunk beds and a storage unit with padded seat can be installed in the opposite wall. To endure long hours of bad weather, stock necessities such as food, water, and blankets. Provide storage space for valuables such as legal documents, irreplaceable pictures, and the family silver.

Where will shelter be located? Will it be located in the house, attached to the house, or will it be located in the back yard? Quick and easy access is a must. When planning a new home, the best location for a shelter is in the center with an entry from a central hallway. For existing homes, an attached shelter with a direct entry from the home is much preferred over a shelter located in the back yard.

Shelters located away from the house have two inherent problems. First, one can be injured on the way to the shelter. If the warning comes too late, one may not have time to reach it. Second, the shelter may be full of neighbors and strangers.

Oklahoma Cooperative Extension Fact Sheets are also available on our website at: <http://osufacts.okstate.edu>

The result is very little, if any, room. Do not lock the shelter when storms are imminent! **A key may not be available.**

Design Considerations

There are three major damaging mechanisms that must be considered in the design of a tornado-resistant shelter.

First: Pressure forces created by high winds (Figure 1). Pressure forces on walls and roofs can range from less than 50 pounds per square foot for a weak tornado to over 200 pounds per square foot for a violent tornado having winds of almost 300 miles per hour.

Second: Pressure forces created by sudden pressure drop (Figure 2). Pressure differences can range as high as 200 pounds per square foot. Sudden pressure drops are not a major problem for adequately vented shelters. The total vent open area (square feet) should be at least .001 x volume (cubic feet) of the shelter.

For a 10 by 10 foot shelter with an 8 foot ceiling, the vent area would be $0.001 \times 800 = 0.8$ square feet, or 115 square inches. Two vent pipes, one 10-inch diameter and one 8-inch diameter, would provide adequate ventilation. If heavy-screen safety covers are used on the vents, increase vent area at

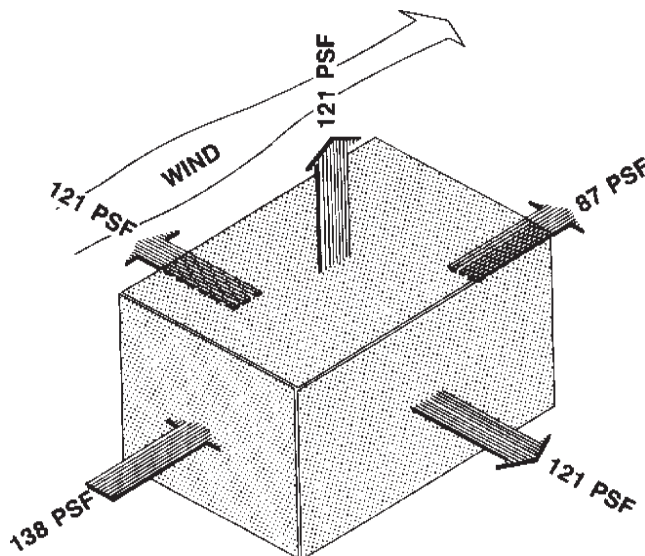

Figure 1. Pressure forces created by 240 mph wind.

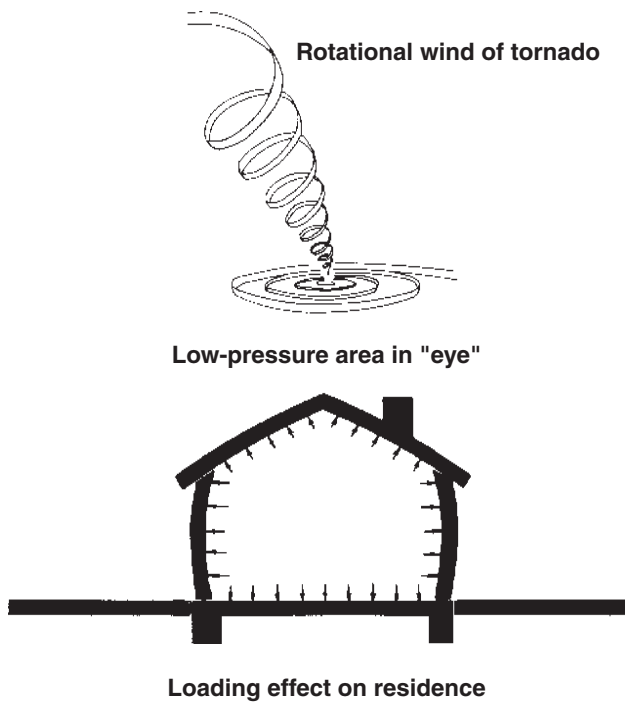

Figure 2. Pressure forces created by sudden pressure drop.

least 25 percent. For the above example, screening would require increasing the vent opening to 144 square inches (1.25 times 115). Then, two 10-inch diameter vent pipes would be needed.

Third: Impact forces created by missiles (Figure 3). Debris carried along by the storm can penetrate improperly designed shelter walls. Missiles can include pieces of houses, utility poles, or the neighbor's TV antenna mast.

Types of Storm Shelters

In-ground

Under-ground shelters have many advantages and are the most popular. The first under-ground tornado shelter was



Figure 3. Impact forces created by missiles.

probably a fruit cellar. These "cellars" did double duty on farms by protecting both canned goods and human life. Earth pressure around an under-ground cellar is the primary load. The roof is usually reinforced concrete and is often covered with earth so the weight of the roof and the covering offset any uplift wind force. Proper venting eliminates pressure forces created by sudden pressure drops. Locate under-ground shelters as close to the residence as possible to minimize problems of getting to the shelter during a storm. Provide counter balanced doors and hand rails on the stairs. Underground shelters may be impractical in areas with a high water table or bedrock near the ground surface.

Berm shelters are constructed very similar to underground shelters but have a few feet of wall above ground. Soil is often piled against the exposed walls to reduce the effects of wind forces and missiles. Install air vents to eliminate pressure forces created by sudden pressure drops. Berm shelters should be located as close as possible to the residence.

In-ground shelters must be strong enough to withstand earth pressures. Earth pressures vary depending upon depth of the shelter below grade, soil type, and soil moisture content. Maximum pressures occur in saturated soils. To minimize reinforcement requirements, install drain lines around the footing and drain to a sump or open discharge. An open discharge is preferred because it is not affected by power outages. Waterproof the exterior of the walls to help keep the interior dry.

Above-ground

Above-ground shelters must be designed to withstand the full force of wind and missiles. The primary advantage of this type of shelter is it can be located inside a new home or attached to an existing home. It can be a bathroom, an office, a large walk-in closet, or a combination of office and storage for valuables. See Figure 4. In-home shelters can be made fireproof, protecting valuables from both storm and fire. A fireproof shelter is not safe for human occupancy during a fire. Above-ground shelters should be designed by a professional structural engineer.

The wall and roof reinforcement must be continuous, from deep piers right up into the shelter roof, anchoring the shelter to the ground. Walls of above-ground shelters are massive—made of either cast-in-place concrete or sand and gravel block with all cores filled with concrete. Walls are reinforced both laterally and vertically. Reinforcement must be designed to resist wind forces plus impact loads of missiles. Unreinforced structures are not safe shelters.

The entrance to the shelter has to be protected from missiles. The entry door can be protected by a reinforced barrier or shelter wall constructed similar to the shelter itself. The roof of the shelter is extended out to stabilize the barrier wall as illustrated in Figure 5.

If there is no barrier wall, the entry can be protected by a massive door, steel reinforced, located on the inner wall surface of the shelter. This massive door, made of doubled 2-inch nominal lumber and covered on the outside with plate steel, should be hung on a top quality overhead door track and braced inside. Use pipe columns or heavy guides in the roof and floor to hold the door in place. Locate the door on the north or east side of the shelter to minimize missile impacts. A second door, a standard entry door, can be installed for everyday use. This hinged door should also open inward so it

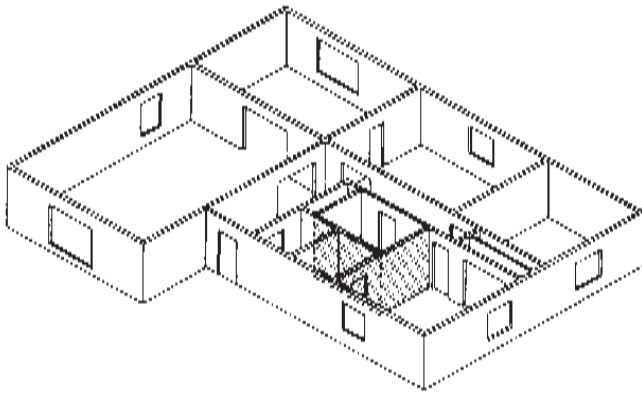
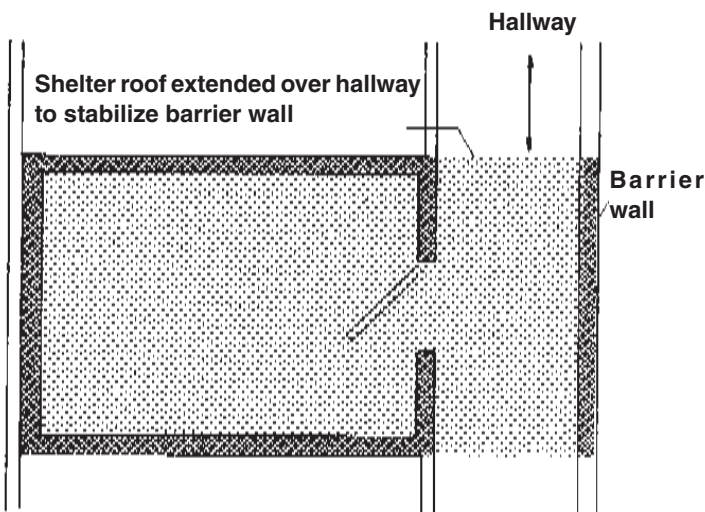
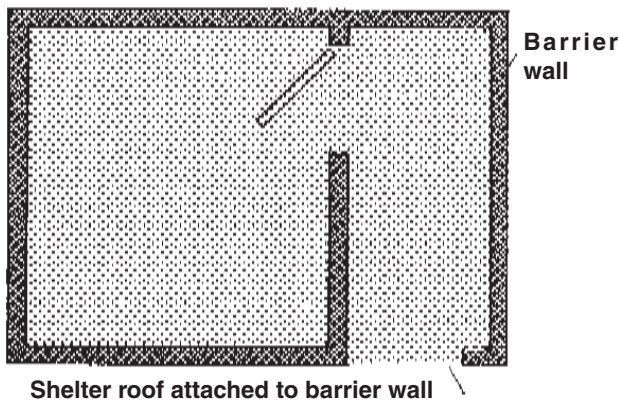

Figure 4. Tornado shelter built within the home.



a. In-home.



b. Outside of home.

Figure 5. Tornado shelter entrances protected by barrier walls

can not be jammed shut by debris. If the shelter is constructed fireproofed, use a fireproof entry door.

Summary

Plan before building. A properly constructed shelter should last indefinitely. Therefore, time spent planning is a good investment. When building a shelter that is a “used” room, such as, walk-in closet, office, or bathroom, you will get more for your money. If it is a multipurpose room, make sure to keep plenty of space free for its primary function—a tornado shelter. If the shelter is part of the residence, it can be easily accessible by children or the elderly.

Underground shelters require stairs that may be difficult to use by older people or anyone that is ill or handicapped.

Build from a plan prepared by a registered engineer or architect. Two standard plans, underground and aboveground designs, can be obtained from the Oklahoma Cooperative Extension Center. Be sure a contractor follows the plan. Changes in the standard plans must be reviewed by a registered engineer or architect. Remember, money spent protecting a life and the lives of loved ones is a very good investment.

Supplies, Tools, and Equipment Needed

In The Shelter

- Food and water for up to two days.
- Flashlights with extra batteries and bulbs, lanterns, or candles.
- Battery operated radio and/or TV.
- Warm clothing, blankets, and sleeping bags.
- First-aid kit, prescription medicines, and other necessities such as baby diapers.
- Some type of toilet facility such as a portable toilet. (This is an advantage of the bathroom shelter.)
- Tools: Large pry bar, crow bar, sledge hammer, hand axe, heavy-duty wood saw, hacksaw with extra blades, adjustable wrenches, large screw driver, safety glasses, and work gloves.

REFERENCES

- “Interim Guidelines for Building Occupant Protection From Tornadoes and Extreme Winds”, TR-83A, Defense Civil Preparedness Agency, September, 1975.
- “Wind-Resistant Design Concepts for Residences”, TR-83, Defense Civil Preparedness Agency, July, 1975.

The Oklahoma Cooperative Extension Service

Bringing the University to You!

The Cooperative Extension Service is the largest, most successful informal educational organization in the world. It is a nationwide system funded and guided by a partnership of federal, state, and local governments that delivers information to help people help themselves through the land-grant university system.

Extension carries out programs in the broad categories of agriculture, natural resources and environment; family and consumer sciences; 4-H and other youth; and community resource development. Extension staff members live and work among the people they serve to help stimulate and educate Americans to plan ahead and cope with their problems.

Some characteristics of the Cooperative Extension system are:

- The federal, state, and local governments cooperatively share in its financial support and program direction.
- It is administered by the land-grant university as designated by the state legislature through an Extension director.
- Extension programs are nonpolitical, objective, and research-based information.
- It provides practical, problem-oriented education for people of all ages. It is designated to take the knowledge of the university to those persons who do not or cannot participate in the formal classroom instruction of the university.
- It utilizes research from university, government, and other sources to help people make their own decisions.
- More than a million volunteers help multiply the impact of the Extension professional staff.
- It dispenses no funds to the public.
- It is not a regulatory agency, but it does inform people of regulations and of their options in meeting them.
- Local programs are developed and carried out in full recognition of national problems and goals.
- The Extension staff educates people through personal contacts, meetings, demonstrations, and the mass media.
- Extension has the built-in flexibility to adjust its programs and subject matter to meet new needs. Activities shift from year to year as citizen groups and Extension workers close to the problems advise changes.

Oklahoma State University, in compliance with Title VI and VII of the Civil Rights Act of 1964, Executive Order 11246 as amended, Title IX of the Education Amendments of 1972, Americans with Disabilities Act of 1990, and other federal laws and regulations, does not discriminate on the basis of race, color, national origin, gender, age, religion, disability, or status as a veteran in any of its policies, practices, or procedures. This includes but is not limited to admissions, employment, financial aid, and educational services.

Issued in furtherance of Cooperative Extension work, acts of May 8 and June 30, 1914, in cooperation with the U.S. Department of Agriculture, Robert E. Whitson, Director of Cooperative Extension Service, Oklahoma State University, Stillwater, Oklahoma. This publication is printed and issued by Oklahoma State University as authorized by the Vice President, Dean, and Director of the Division of Agricultural Sciences and Natural Resources and has been prepared and distributed at a cost of 20 cents per copy. 0507