

GLASS BEADS: TOWARDS AN ALTERNATIVE  
APPROACH TO THE SCIENCE OF  
SOCIAL PSYCHOLOGY

By

CORNELIS GEORGE BOEREE

Bachelor of Arts

Pennsylvania State University  
University Park, Pennsylvania

1974

Submitted to the Faculty of the  
Graduate College of the  
Oklahoma State University  
in partial fulfillment of  
the requirements for  
the Degree of  
MASTER OF SCIENCE  
July, 1979

Thesis  
1979  
B 672g  
Cop. 2



GLASS BEADS: TOWARDS AN ALTERNATIVE  
APPROACH TO THE SCIENCE OF  
SOCIAL PSYCHOLOGY

A handwritten signature in cursive script, appearing to read "B. L. ...", positioned above a horizontal line.

Thesis Advisor

A handwritten signature in cursive script, reading "William H. Rambo", positioned above a horizontal line.

A handwritten signature in cursive script, reading "Larry Hochhaus", positioned above a horizontal line.

A handwritten signature in cursive script, reading "Norman P. Durham", positioned above a horizontal line.

Dean of the Graduate College

1031807

## PREFACE

In Hermann Hesse's novel Magister Ludi, scholars in the future kingdom of Castalia play the Glass Bead Game. The players carry the patterns of relationships they find in works of art, music, literature, science, philosophy, mathematics, and history through patterns of transformations, finding joy in the counterpoint of expectations met, shattered, and met anew. The novel's own counterpoint lies in the thesis and antithesis of Castalia and the world, and the search of Joseph Knecht, Master of the Game, for the resolving theme.

We find a similar dialectic in Pitirim Sorokin's theory of cultural mentalities. He contrasts the Sensate--worldly, materialistic, empirical--with the Ideational--spiritual, realistic, faithful. Each has its virtues and its vices. Sorokin does, however, offer us a respite from these partial mentalities, in the infrequent Idealistic. This variety blends faith and empiricism with reason. In my opinion, the Idealistic Mind finds its ultimate expression in Spinoza.

Some time has past since then, and the pendulum has gone through its periods once or twice. It seems to me that psychology has suffered both from mechanism and

scientific spiritualism, as well as from awkward combinations. Although the extremes have contributed to understanding and will continue to do so, they suffer in their effectiveness by splitting the scientist. This thesis is a small attempt at rejoining the objective and the subjective, the secular and the spiritual, the mind and the body, an attempt at mending at least one scientist. Whether or not it is successful is left to the judgement of the reader. If nothing else, I hope it brings the possibility of this Idealistic alternative to the attention of a better mind than mine.

My deepest thanks go to Dr. Helm, Dr. Rambo, and Dr. Hochhaus, for having encouraged me in this endeavor; to my parents, George and Eberdina Boeree, for their sustaining pride; and especially to my wife Judith and daughter Jennifer, for their patience and love.

Nobis semper sit amor.

## TABLE OF CONTENTS

Chapter	Page
I. INTRODUCTION . . . . .	1
Defining Terms . . . . .	3
II. METAPHYSICS . . . . .	6
III. THEORY . . . . .	10
Interaction . . . . .	12
Affect . . . . .	16
IV. MODEL . . . . .	19
Networks . . . . .	19
Language . . . . .	29
Semantics . . . . .	34
V. METHOD . . . . .	40
VI. IN THE WORLD . . . . .	46
Beginnings . . . . .	46
Relationships . . . . .	49
Father . . . . .	51
The Chief's Son . . . . .	55
Blessed Resolutions . . . . .	58
A Problem of Semantics . . . . .	61
The Curandero . . . . .	64
Endings . . . . .	67
BIBLIOGRAPHY . . . . .	69
APPENDIX . . . . .	75

## LIST OF FIGURES

Figure	Page
1. Littoral Society . . . . .	13
2. Interaction . . . . .	13
3. A Portion of Tzeltal Ethnobotany . . . . .	24
4. A Portion of a Western Ethnobotany . . . . .	24
5. Truk Kinship . . . . .	25
6. A Partial Analysis of the Rules of Baseball . .	26
7. Narrative Analysis . . . . .	27
8. Lexotactics, Realization, and Morphotactics . .	32
9. The Interaction of Narrative and Taxonomy . . .	35

## CHAPTER I

### INTRODUCTION

Pious thinkers of earlier times had represented the life of creatures, say, as a mode of motion toward God, and had considered that the variety of the phenomenal world reached perfection and ultimate cognition only in the divine Unity. Similarly, the symbols and formulas of the Glass Bead Game combined structurally, musically, and philosophically within the framework of a universal language, were nourished by all the sciences and arts, and strove in play to perfection, pure being, the fullness of reality. Thus, "realizing" was a favorite expression among the players. They considered their Games a path from Becoming to Being, from potentiality to reality (Hesse, 1969, pp. 30-31).

More than anything else, this may be said to be the age of specialization. We need not beat our breasts-- specialization is (in part) only the recognition of our limitations. But there is a danger: that we do not know enough beyond our fields of interest to progress within them. We have begun, in the last few years, to look at our ignorance and our assumptions. This comes as a reaction to a professional malaise: We seem to be progressing at a far slower rate than was predicted only decades ago; Society is demanding relevance, with all its definitional variations, from the social sciences; The ethics of experimentation on people are being scrutinized; The possibility of ever understanding human beings is



being questioned.

Self-examination by social psychologists is bound to generate heated debate: Perceptions of what lies behind our problems range from lack of rigor in traditional research (e.g. Schlenker, 1974) to the inapplicability of traditional research methods to human problems (e.g. Gergen, 1973). Common solutions to this vague problem include greater attention to the environment (Altman, 1976; Secord, 1976), greater attention to the individual (Gadlin and Angle, 1975; Rychlak, 1976), interdisciplinary work (Altman, 1976; Mancuso, 1976; Secord, 1976), cross-cultural work (Gadlin and Angle, 1975; Secord 1976), increased use of observational techniques (Altman, 1976; McGuire, 1973; Secord, 1976), increased rigor in experimental techniques (Schlenker, 1974), putting our theories and hypotheses into mathematical form (Harris, 1974, 1976), and so on ad libitum.

Seldom, however, is it considered that perhaps our basic orientation, our very "world-view," is inappropriate to the subject of our concern: Gergen (1973) suggests that social psychology is an historical study rather than a science concerned with universal laws of behavior; Harre and Secord (1973) offer a world-view based (roughly) on Kant rather than positivism; and I can only applaud their efforts. But we must go further than just replacing one world-view with another. So long have we trusted to Kuhn's (1970) analysis of the paradigmatic

and the pre-paradigmatic that we assume that our science must progress in the manner he has proposed. I suggest an alternative: that we generate a number of "paradigms"--world-views--and that these be used in a spirit of cooperation rather than competition. Reality is big enough to be open to many views, not one of which is entirely correct or entirely incorrect.

This is by no means an easy task. Yes, we all, implicitly or explicitly, carry around world-views. But rarely are these casual world-views both extensive and internally consistent. And every world-view carries with it theory, models, methods, and metaphysics, each dependent on the others. And any good world-view, insofar as it concerns human beings and the thoughts they have, must be able to include itself--i.e. must be capable of reflexivity. Finally, and perhaps most importantly, a world-view must satisfy the aesthetic instincts of the individual scientist. This is the final test of any world-view. To generate one such world-view is the perhaps absurdly ambitious task of the present paper.

#### Defining Terms

Let me outline the task by presenting a number of words as I understand them. Science is organized knowledge; it is valuable inasmuch as we perceive the world by interpreting what we sense in terms of our own structures, and so the measure of our organization is the

measure of our ability to handle the complexities of living in reality. Science is not equivalent to the methods used by scientists: Observation and experimentation, the formation and testing of hypotheses, are hardly restricted to the scientist, or perhaps even to the human being. The difference between the scientist and the non-scientist lies in the care which the former takes (or should take) in making his observations and experiments. I mention this only so that we realize from the start that there is no debate over whether or not psychology is a science, or whether or not human beings should be "subject" to scientific study. As much as we all study people carefully, so much are we all scientists.

For the purposes of this thesis, metaphysics is the set of assumptions which one finds to be irreducible and from which one can deduce the range of possibilities one expects to find in experience. As traditional psychology is based on positivism and its forebearers, and Harre and Secord's model is based on Kant, so the metaphysics here presented finds its roots in the spirit (if not the letter) of Spinoza.

A theory gives explanatory significance to our observations, always within the range defined by our metaphysics. It is a tool to be used to guide further inquiry. It is open to constant modification and even replacement.

A model is the means by which we go from theory to

method. A model is an explicit and systematic analogy, drawn from theory, which attempts to match reality, not in the essence of its workings but in its consequences. Care must be taken not to confuse the metaphors of the model with those of the theory: The latter are far more "serious" than the former, and far less manipulatable.

At last, we come to method. Although it sits at the "bottom" of our world-view, it is possible the cause of more argument in psychology than metaphysics, theories, and models combined. I suggest this is so because it contains within itself our metaphysics, theories, and models, yet often turns about and questions the roots from which it grew. It has been impressed upon me that the best method is the formal laboratory experiment, that this method is the one which all others can only approximate in effectiveness. The reasons for believing this are well known and need no review here. And so it is likely that the portion of this paper which will be subject to most criticism is the one on methods: I believe that the most basic method is one wherein the scientist attempts to become that which he studies.

## CHAPTER II

### METAPHYSICS

Theory grows from the confluence of what we see--our empirical data--and what we believe--our metaphysical assumptions. To attempt a theory without empiricism is to expound dogma without touching life in the world; To attempt a theory without metaphysics is to list observations without giving them meaning. Although it has been popular in this century to denounce metaphysical speculation as lacking utility, it can hardly be denied that we all make very basic assumptions about the world, assumptions that may not be testable in any empirical sense. If all I believe is that I experience reality veridically, or that my intuitions are sound, or that what has worked before must work again, or that reality is lawful, I am holding to a metaphysics indescribably complex. Not stating our assumptions will not magically make us objective observers of the world: Our assumptions shine through every observation we make, every word we utter.

As I became aware of my discomfort with traditional psychology, I also became aware that my metaphysics was rather different from others I had been exposed to,

and that this difference might lie at the root of my discomfort. The purpose of this section is to elucidate, not all my assumptions (that task is far beyond the scope of this paper), but those at variance with the generally accepted metaphysics.

1. The universe is pluralistic to the infinity of detail, so as to be indistinguishable from the monistic. Like fleas with smaller fleas upon them, things can be seen as composed of molecules, the molecules as composed of atoms, and so on. Physics is presently detained with quarks, but Chinese physicists have already suggested stratons--an infinite regression of "atoms." The parts need not be solid little building blocks. A chair may be thought of as composed of atoms, or waves, or potential fields, or even variations of probability:

If one wants to give an accurate description of the elementary particle--and here the emphasis is on the word "accurate"--the only thing which can be written down is a probability function. But then one sees that not even the quality of being (if that can be called a "quality") belongs to what is being described. It is a possibility for being or a tendency for being (Heisenberg, 1958, p. 70).

The principle remains the same: Without an ultimate particle, the "grain" of the universe approaches the infinitely fine; there are no lines to separate A from B, and every thing is a "convenient construct."

2. Space and time are only aspects of a unitary time-space manifold. Consider time as another spatial dimension, at right angles to all our other dimensions.

We, due to our humble construction, perceive time as passing: We cannot see through past or future eyes, nor touch with past or future hands. But think of each moment of our view of time as a photo slide, and stack them in order. If the films are as thin as the distance between the photochemical dots that make up each picture, and are fused together to make a solid block, you have a model of space-time:

Each observer, as his time passes, discovers, so to speak, new slices of space-time which appear to him as successive aspects of the material world, though in reality the ensemble of events constituting space-time exists prior to his knowledge of them (de Broglie, in Schilpp, 1959, p. 114).

Now notice that the photochemical dots between slides (i.e. on the time dimension) have the exact same relation to each other as the dots within a slide. The difference from moment to moment is the same as that from point to point. Conceived in this way, the world is determined but not causal. What we see as cause-and-effect is the structure of the time-space manifold.

3. Mind and matter, the mental and the physical, are only aspects of a unitary aesthetic continuum. "The decision of the mind, and the desire and determination of the body. . . are one and the same thing" (Spinoza, 1951, III, 2). This position is a familiar one, psychophysical parallelism, and it comes in two important species. One is Russell's, James', and Dewey's neutral monism and the functionalism derived therefrom: Mind is a certain

working of the body. The other is Spinoza's, Leibnitz', and Bergson's identity theory and the panpsychism derived therefrom: All is conscious. It is this second kind that I accept. We don't need to ask "How do I change light particles refracting in the atmosphere and exciting molecules in my retina into an experience of blue?" These events are blue. And you don't see an image of the sky on your retina or anywhere else; You see the sky.

We may summarize these three assumptions by saying that, in essence, there are no things, but only a single, holistic structuring of the single form, the time-space manifold, the aesthetic continuum.

4. Finally, we must find a place for man in this "buzzing, blooming confusion:" Sentience occurs when aesthetic space-time turns inward upon itself, becoming a partially independent system so as to be capable of interacting with its environs. We are whirlpools in the ocean of experience. It is we who separate space and time, mind and matter, the parts from the whole. Intransigent opposites are created in the minds of men.

Although it may so appear, this is not just a personal perspective, but is closely tied to what Huxley called "the perennial philosophy." It is shared by many mystics, some physicists, and a few psychologists. And assumption of this point of view colors one's entire approach to psychology, science, and life.



## CHAPTER III

### THEORY

(The self) is a drop of the cosmos, and its surface tensions bespeak only a fragile and indefinite barrier that marks a region of relative structuring, relative independence. This structuring and independence exist only because they are relative, that is, because of the confluence of the self and the non-self. As the musician melts into and identifies with his beloved instrument, the Hopi Indian on the rim melts into his Grand Canyon (Murphy, 1966, p. 7).

The mystic's metaphysics has left us with a nebulous image of man indeed! In a sea composed of minute currents of experiential relationships--of color and sound, shape and weight--all without edges, all frozen into a four-dimensional block, we discern a pattern, a world-line resembling the branching of a tree: Life. This tree has partially separated itself from the rest of the ocean by having more aesthetic eddies turning in upon itself. Now I must admit that this image is more suited for meditation than for dealing with the practical problems of being-in-the-world. A less cloudy metaphor is needed to accomplish the transition from metaphysics to a theory of sentience.

Let us envision our aesthetic continuum as the distribution of thermal energy in space. When the heat from the sun reaches the earth, the earth absorbs it, but

unevenly--depending on the arrangements of sea, land, and air. At night, this heat is released into the atmosphere, again unevenly, where it meets and interacts with the heat from the sun, to make the weather. The distribution of thermal energy on the earth is far more complex than that beyond it, and a larger proportion of that distribution is involved in relations with itself than is involved in relations with the distribution of thermal energy beyond the earth. To bring us back to ourselves, the sun represents the environment, the earth the human being, and the inward-turning distribution of thermal energy--roughly, the weather--is reflective consciousness.

A second metaphor: If a land has an irregular coastline, its littoral communities tend to form an ecosystem separate from the communities farther inland; If a land has a regular coastline, the coastal people remain tied to those inland. This is thought to be because, as the coastline has more bays, coves, capes, etc., any particular littoral community is more likely to be in contact with other littoral communities than with inland communities. In Figure 1, A is in contact with three inland and two littoral groups; B is in contact with three inland and four littoral groups. If a littoral ecosystem is to arise, it is more likely around B (McEvedy, 1967). The sentient organism is like a coastal society--differentiated from the great continental empire

of environment by the greater relationship it has with itself.

### Interaction

There are certainly inputs from and outputs to the environment--I will call these sensations and actions. But the complexity of the inward-turning of the organism will not usually allow for a simple connection between sensation and action. The structuring within rather presents itself in anticipation of sensations and actions, as the earth displays its oceans and continents, or the sea-faring society greets inland traders with a delegation whose form derives from the society's economic organization. Inasmuch as the presented structuring is appropriate, life goes on unchanged. But when the anticipation is incorrect, the structuring must adapt itself to meet new requirements--like the society must change itself when the inlanders introduce money or slaves into the marketplace. So the organism anticipates the environment, adapts to incongruities between its anticipations and sensations with further anticipations, many of which manifest themselves as actions upon the environment, and so on, continuously, fluidly, ever-presently. This is interaction, and is roughly summarized in Figure 2.

Of course, we are not always reflexive: Occasionally, we sink into dreamless sleep or fall "unconscious." And

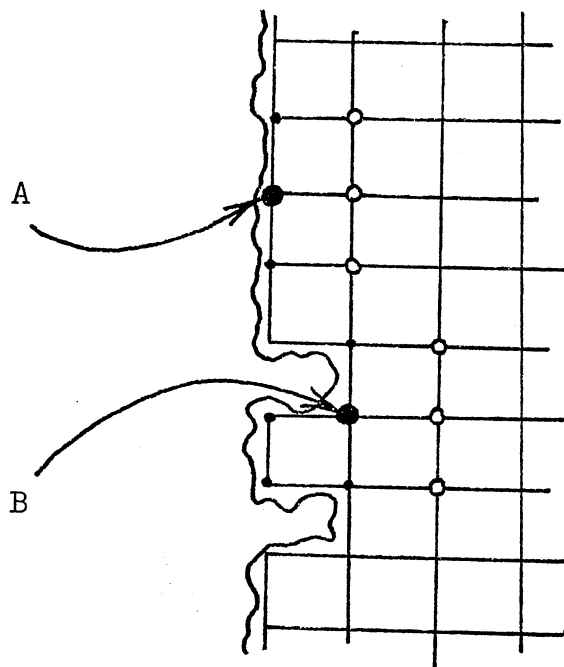

Figure 1. Littoral Society

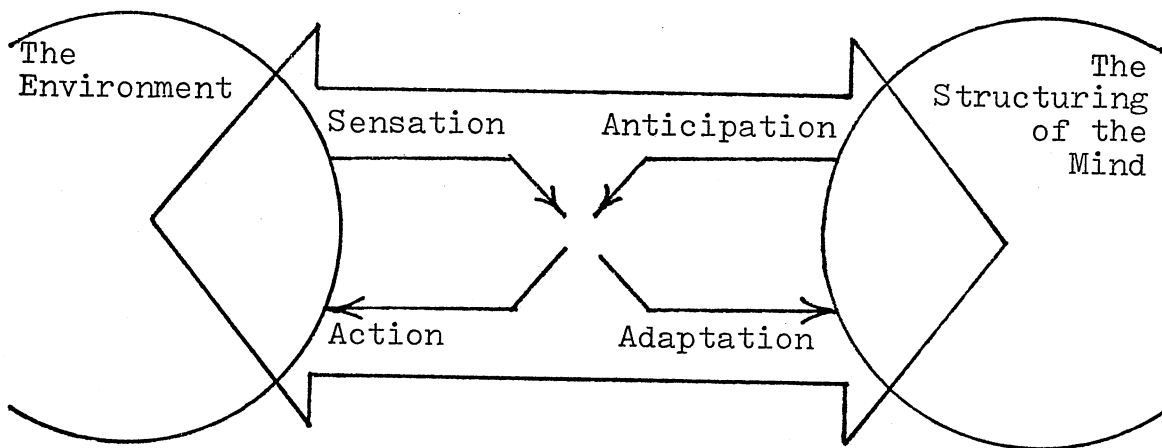

Figure 2. Interaction

occasionally we become almost entirely reflexive, ignoring the world while we become engrossed in anticipations divorced from sensations and actions--dreaming, thinking, remembering, imagining, reflecting. We return to the full interaction cycle through the entry points of reflexes and those more complex reflexes we call instincts:

Loud noises, rhythmic repetitions of stimuli, sudden visible movements, and painful stimuli are examples of signals that we are always ready for. Infants are surely born with schemata to accept such information, which is used to begin new cycles of perceptual activity (Neisser, 1976, pp. 94-95).

I mentioned "reflecting." Let me again quote from Neisser (1976) to explain: "Images are not pictures in the head, but plans for obtaining information from potential environments" (p. 131); "Perception is a cyclic activity that includes an anticipating phase; imagery is anticipation occurring alone" (p. 147). Let me add that thinking is anticipation and adaptation: Insofar as our structural organizations are never complete, we are able to present ourselves with incompatible anticipations, which we must "rationalize" by adapting to.

How do we get objects and acts from sensations and actions? I might refer you to the work of J. J. Gibson (1966), but let us see if we can be more succinct: An object is a collection of sensations interrelated in such a way that to anticipate one part of it is to anticipate all of it. While the potential relationships the object has outside itself are potentially infinite, the

relationships within remain (more or less) constant and so are anticipatable as a whole. Likewise, an act is the set of actions which an anticipation generates together, e.g. certain muscle groups functioning cooperatively. In even more succinct terms, objects and acts are gestalts.

Often enough, though, we impose "gestalting" on collections of these gestalts: While individual finger movements may be proper acts, the bar of music we play on the piano has an integrity beyond muscle coordination. This is the same as saying that we are capable of anticipating sets of anticipations, of forming simple acts and objects into unified wholes by applying rules to them. In this manner we provide a larger context for various events in our lives; we give meaning to the meaningless.

Learning, beyond the simple connection between an object and an act, is then the associating of a gestalt or gestalting with a place on a higher level of gestalting. Many writers speak of learning as the creation of metaphors. When a new event can be substituted into an old pattern, we have a metaphor. So in our formulation of adaptation, we accomplish metaphors as we accomplish associations: When an anticipation is unsuccessful, we must try and try again, "acting" (if by acting we mean anticipation as well as action) on the situation until we can anticipate successfully, building with old structures a new structure capable of dealing with the new event.

## Affect

This interactional process we have been discussing is not, however, "transcendental"--it grows from biological roots. While to some extent we can regard the individual's physical presence as just another set of environmental events, evolution has provided modulating relationships between the "somatic environment" and the interaction process, no doubt in the interest of survival.

As I mentioned before, we must at least occasionally attend to the world, and so are provided with inborn structuring--instincts and reflexes. We react, we orient ourselves, we hunger, we thirst, we seek sexual activity. Perhaps we also defend, attack, seek the company of others, and so on. These are no different than the structures we learn--we just don't learn them. But learning is one of the strongest survival mechanisms around, and it appears we are driven to learn far beyond our immediate needs. Why?

When we are hungry and we eat, we feel pleasure. A structure within us is "incomplete," and as we complete it, we enjoy the act. When we are satiated, the pleasure draws to a close, and we wait until the structure "breaks down" once more. Pleasure is in the approaching. We also feel irritation: The longer a structure remains incomplete, the greater is our irritation.

I suggest that this same phenomenon occurs on a more

cognitive level. Adaptation--the increasing of structure--is directly perceived as pleasure, ranging from mild effectance to the "Eureka" experience. Likewise, as anticipation is frustrated, we experience irritation, ranging from mild annoyance to terror. Besides being direct experiences of our "states of mind," we also perceive reflections of pleasure and irritation in the variations of tension in the somatic environment.

Individual, personal consciousness is the weaving of loose threads: Our experience of consciousness lies in growth and the need to grow, in the interactions where we find anticipation-and-adaptation. So, consciousness occurs only in conjunction with the pleasure-irritation dichotomy discussed above, or, more correctly, is identical with the experience of pleasure and irritation. Unconsciousness lies in interaction wherein adaptation is absent. Consciousness and unconsciousness so defined place this theory squarely in the existentialist camp: Without the pains and pleasures of being-in-the-world, we are automatons; Growth is equivalent to consciousness.

Attending and ignoring are complementary: They are anticipatory "acts" which draw an event from the background of experience into consciousness, or push an event into that background. "To pick one apple from a tree you need not filter out all the others; you just don't pick them" (Neisser, 1976, p. 85). In the proverbial crowded bar, we attend to the semantics of our friend's



conversation. We certainly anticipate the sounds and syntax of our friend's sentences--if he were to start speaking Russian, we would surely notice. And certainly we anticipate the existence of noise and other conversations all around us--if it were to suddenly become quiet, we would again surely notice. One can ignore the sense of a conversation by anticipating the sounds of that conversation consciously. Or one can attend to the "sense" of a familiar object or act by searching for its anomalies, by making it unfamiliar, by analyzing it. When an event is attended to, we are conscious of it; when it is ignored, we are not conscious of it. But an event more often enters consciousness of itself, without the effort of attending, by being what we do not know; and an event more often recedes into unconsciousness, without the effort of ignoring, by being what we know.

"Clouds of spinning atoms" may give a chemist a fairly concrete image of the reality he must work with, but this image will not help him greatly in "doing" chemistry. We must now (for a while) leave the realm of poetry and try to develop a model of mind which we can manipulate, with which we can "do" psychology. We must map the currents and eddies of experience.

## CHAPTER IV

### MODEL

In the preceding sections, we have seen a portion of the experiential world pull itself away from the rest and establish partial autonomy. We who are part of this autonomous portion interact with the world by anticipating, as best we can, what the world presents to us. Success in this endeavor means survival. Success means we have within us a model--a map, never fully accurate, always developing--of the world and our relations with the world. The purpose of the following sections is, in turn, to develop a model of these models. Science is, perhaps, the art of making better maps. Psychology has a very central role in science in that it attempts, in essence, to map the map-maker.

### Networks

We could represent our neurological apparatus at any moment in time with interconnecting strings and knots of string, the signals traveling over this network as tiny nodules sitting on the string. With time, the strings and knots extend into the fourth dimension as planes, and the signals as ridges on these planes. Other possible models

of the central nervous system include electronic, hydraulic, and mechanical systems, information processing systems, and postulated "pseudoneuron" and "neuronidae" systems (e.g. Culbertson, 1963). Let us, however, remain with the "knit sweater," since it has so few "parts:" This image is particularly appropriate as a map of those currents and eddies that are the experiential aspect of the nervous system.

"(A) totality does not consist of things but of relationships" (Hjelmslev, 1961, pp. 22-23). With this inspiration, Sidney Lamb invented a network notation for linguistic systems quite congenial to our image of man. Unlike other models dealing with "information" (i.e. experience), nothing processes the information. Minute "currents" split in two, come together, halt the progress of other currents, or turn about on themselves like the tides.

The notation consists of a network of lines connected by a number of nodes. The lines are thought of as transmitting signals in either direction. The nodes are "triggered" by one or more incoming signals, then send out signals in a pattern defined by the type of node:

1. And node:

If a, then b and c;

If b and c, then a.



## 2. Or node:

If a, then b and c;

If b, then a;

If c, then a.



## 3. Andor node:

If a, then b and c;

If b, then a;

If c, then a;

If b and c, then a.



## 4. Triangle node:

If a, then b;

If b, then c;

If c, then a.



## 5. Circle node:

If a, then b and c;

If b, then a and c;

If c, then a and b.

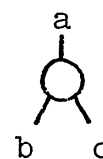

## 6. T node:

If b, then a and ON;

If c, then a and OFF;

If a and ON, then b;

If a and OFF, then c.



7. Zero node:  
If a, then nothing.



8. Tactics node:  
If a, then a.



9. R-set node:  
If t, then r and t.

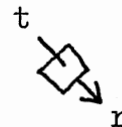

10. S-set node:  
If t and OFF, then ON;  
If s and ON, then t and OFF;  
If t and ON, then OFF.

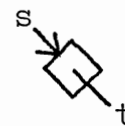

11. Diamond node:  
If t and OFF, then ON;  
If a and ON, then b and t and OFF;  
If b and ON, then a and t and OFF;  
If t and ON, then OFF.

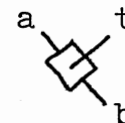

Any other inputs to these nodes results in no output at all. Please note that these are my interpretations of Lamb's nodes and are slightly different. They remain true, however, to their inventor's intentions.

This small set of nodes, used properly, has an enormous descriptive range. The interested reader may wish to examine the following simple examples, Figures 3

through 7, included here as a testament to this range.

In all these diagrams, there are "loose ends," lines with three dots and a word or description. A more complete diagram would have (after further developments replacing the three dots) diamond or set nodes, relating the structure diagrammed to the rest of cognitive structure or to the subjective environment. The sum of all such nodes that are active ("ON") at any point in time represents anticipation. Adaptation, in turn, is the establishment of new nodes, or, more precisely, the functional differentiation of nodes which are already (implicitly) in intermediate positions throughout the network.

Before I am accused of being a simplistic mechanist, allow me to point out the limitations of the network notation for you:

1. The network is a representation of only a portion of a completely interacting whole. The division of the individual from his environment is an artificiality we must live with, and is to some extent justified by the fact that we ourselves make that distinction phenomenologically (to a large degree, anyway). But the artificialities of taxonomy-rule-narrative distinctions and even the choices of convenient nodes are far more difficult to justify. And the artificialities of subdividing the individual into (e.g.) morality, person-perception, language, and other "areas" are justifiable

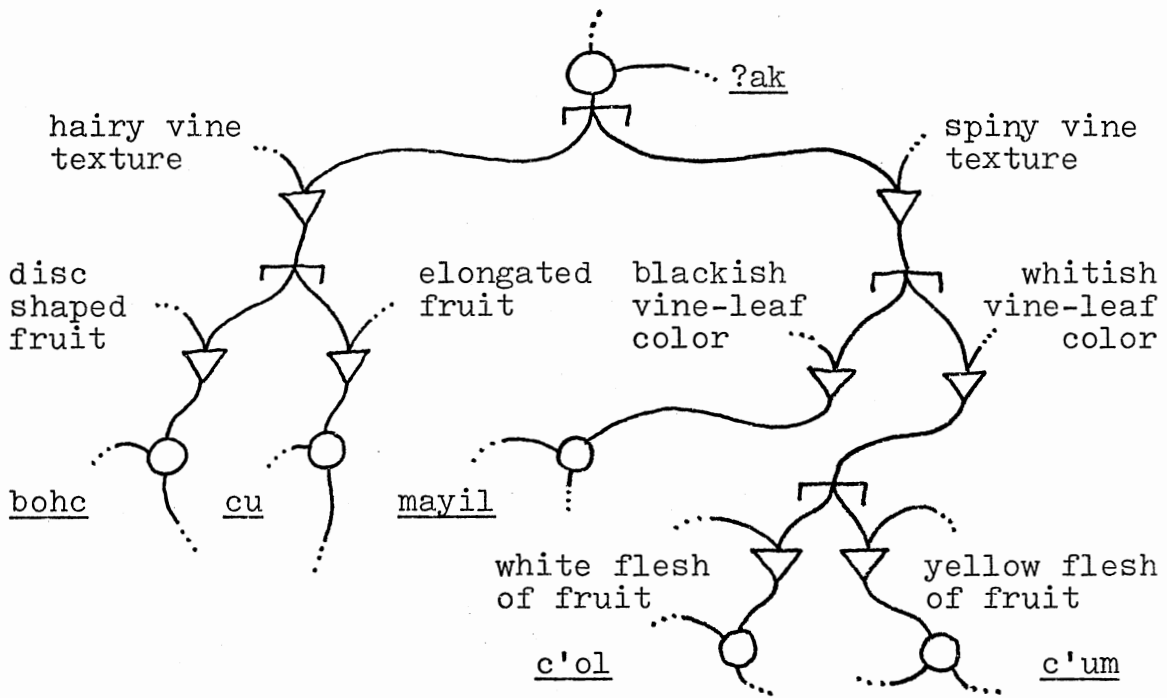

Figure 3. A Portion of Tzeltal Ethnobotany (derived from Berlin, Breedlove, and Raven, 1970)

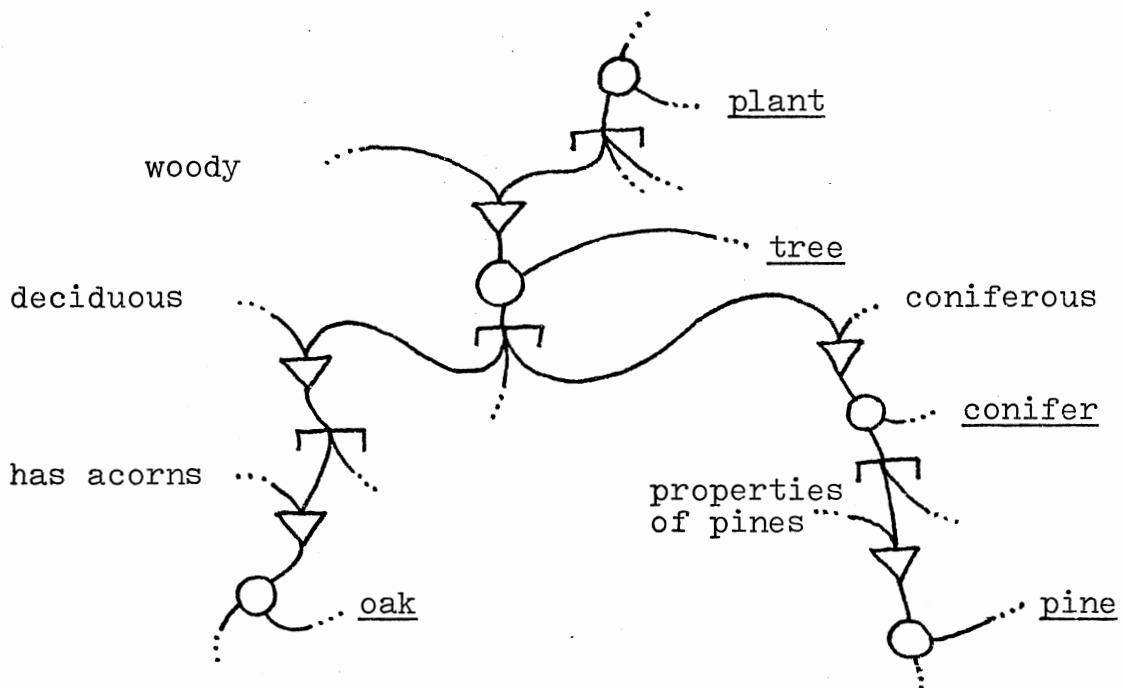
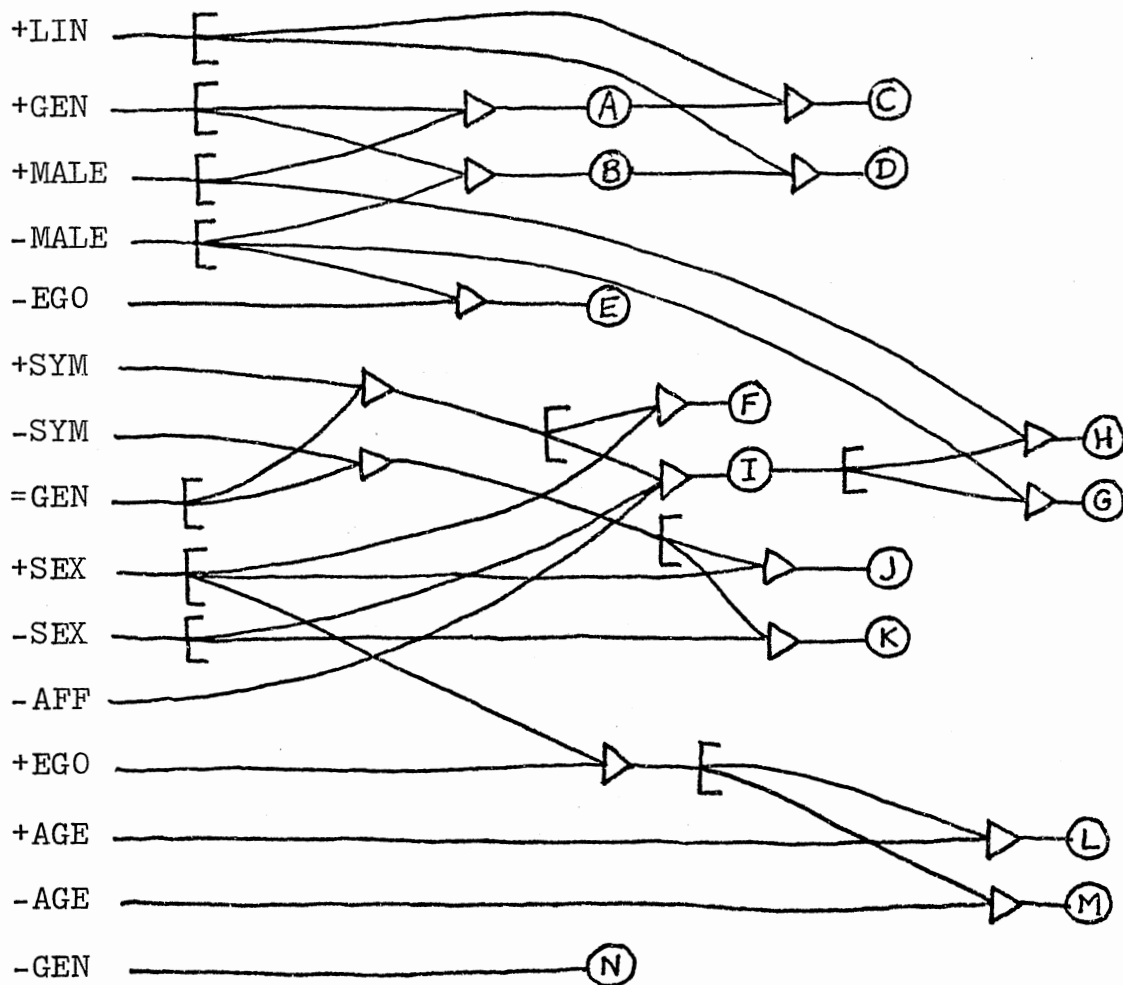

Figure 4. A Portion of a Western Ethnobotany (adapted from Lockwood, 1972)



- +=-GEN Seniority of generation (senior, same, junior).  
 +-MALE Sex of relative (male or female).  
 +-SYM Symmetry of relationship to connecting matrilineal group (symmetrical or assymmetrical).  
 +-SEX Sex relative to ego's sex (same or different).  
 +-AFF Mode of relationship (affinal or consanguinal).  
 +-AGE Age relative to ego's age (older or younger).  
 +-ØEGO Matrilineal group membership relative to ego's (ego's, ego's father's, neither).  
 +-LIN Collateral remove (lineal or non-lineal).

A	<u>semej</u>	F	<u>pwijj</u>	K	<u>pwynywej</u>
B	<u>jinej</u>	G	<u>feefinej</u>	L	<u>jaa j mwaan</u>
C	<u>semenapej</u>	H	<u>mwaani</u>	M	<u>mwaaninyki</u>
D	<u>jinenapej</u>	I	<u>mwegejej</u>	N	<u>nejj</u>
E	<u>jinejjisemej</u>	J	<u>jeesej</u>		

Figure 5. Truk Kinship (derived from Goodenough, 1956)



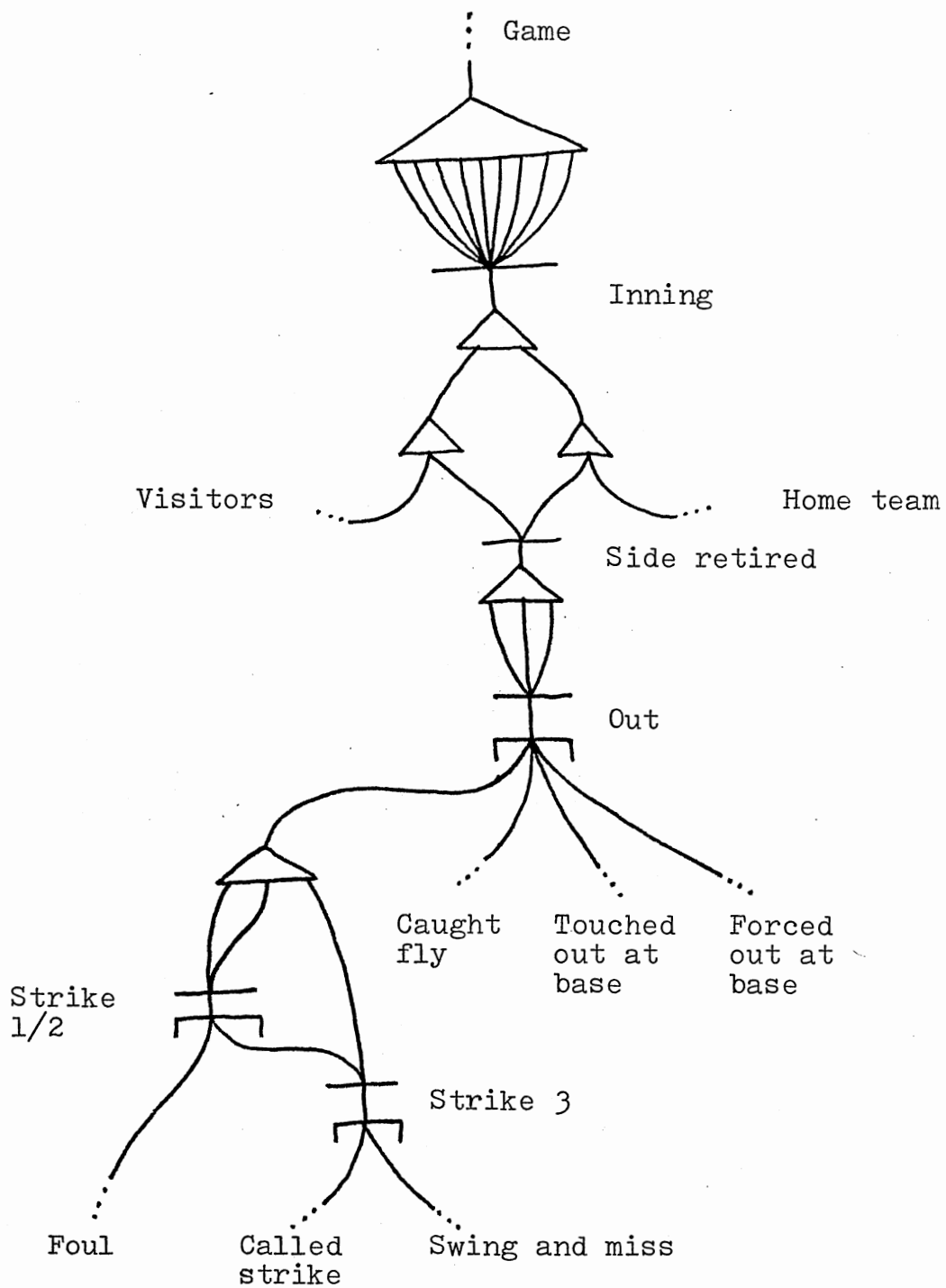
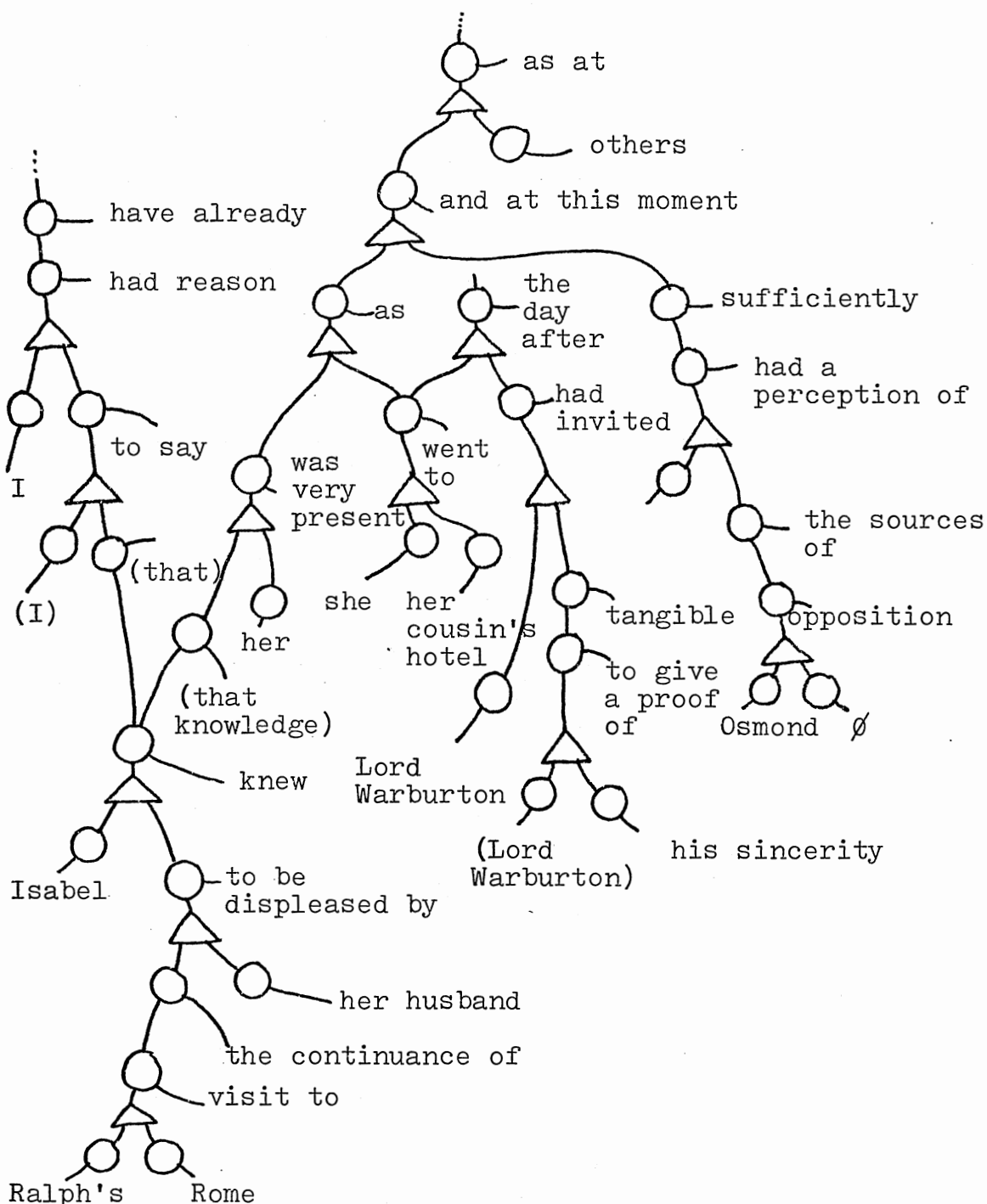

Figure 6. A Partial Analysis of the Rules of Baseball  
(adapted from Lamb, 1964)



Ralph's Rome  
 "I have already had reason to say that Isabel knew her husband to be displeased by the continuance of Ralph's visit to Rome. That knowledge was very present to her as she went to her cousin's hotel the day after she had invited Lord Warburton to give a tangible proof of his sincerity; and at this moment, as at others, she had a sufficient perception of the sources of Osmond's opposition." (Henry James, 1909, p. 245)

Figure 7. Narrative Analysis

only in terms of our limitations.

2. The network is a slice of time-space, a representation of a portion of someone's structure at a point in time. It misses the constant adaptation of the individual to the environment (and to himself). A great part of daily experience is not prescribed by one's structure, is not set down in rules, but must be dealt with through the metaphorizing of anticipation-and-adaptation. Even if our network were complete, we are not dealing with the individual as incomplete, ever growing, ever developing.

3. Finally, network notation (like logic, mathematics, and so on) is itself a manifestation of human structure, and so--this is quite obvious--is itself growing, changing, adapting. Like all things human, the elements of notation are chosen, the rules defined. Insofar as we abide by these choices, a logical system is universal (in the philosophical sense). But--given the metaphysics here assumed--it is inevitable that an event occur for which no contingency is planned.

In defense, I might add that any system of science, philosophy, or mathematics, or work of art or literature, has these very same drawbacks. The works of, say, Voltaire may be complete unto themselves; But they are not Voltaire. We model creations, not creation itself.

## Language

Language may serve as a paradigmatic form of much of the rest of our cognitive structuring: 1. Language is a generative system--it is capable of generating (or accepting) an infinite number of events with the use of a finite number of parts; 2. Language is a parallel system--it connects interactions involving a relatively small set of gestalts (the sounds of a language) with interactions involving a broad set of gestalts (the events one describes or imagines, both of which proceed simultaneously; 3. Language is partially independent of the rest of our structuring, similar to the way we are partially independent of our environment.

Considering its complexity, if we can model language with a network, we have gone a long way toward demonstrating the efficacy of the network as a model of the totality of our cognitive structuring. It is, of course, precisely this which occupies the stratificational linguistics that developed from Lamb's initiatives.

Stratificational linguistics views language as several strata of systems, each of which is relatively independent. Six strata are recognized: On "top" is the hypersememic (a.k.a. semantemic, a.k.a. gnosemic) stratum, which deals with substance; On "bottom" is the hypophonemic (or phonetemic) stratum, which deals with articulation; Between these we find, from top to bottom,

the sememic, lexemic, morphemic, and phonemic strata. This arrangement is paralleled by Leech (1974), who proposes a deep and surface level of semantics, syntax, and phonology (with somewhat more traditional interpretations).

A strata is defined by a tactics portion acting on a realization portion which provides structural relations with the strata above and below. Leech again parallels nicely: He distinguishes (in discussing semantics) between contrastiveness as the "paradigmatic" or selectional axis (essentially componential analysis) and constituent structure as the "syntagmatic" or combinatory axis (like the traditional tree diagrams). This distinction is the same as that made between realization and tactics respectively.

To give you a flavor of the different strata, here are a few English examples: 1. On the hypophonemic stratum, a bilabial voiced plosive ("b") or a labiodental voiced fricative ("v") is acceptable, but a bilabial voiced fricative (such as the Spanish "v" in "Havana") is not; 2. On the phonemic stratum, "slithy toves" is acceptable, but "shtroogeh psokshi" is not; 3. On the morphemic stratum, "supercalifragilistic" is acceptable, but "hoodmother" is not; 4. On the lexemic stratum, "colorless green ideas slept furiously" is acceptable, but "dog the house the of out kick" is not; 5. On the sememic level, "he put out the sun" is acceptable, but "he put it

from the car" is not; 6. On the hypersememic level, "he is his mother's son" is acceptable, but "he is his mother's father" is not.

To give you a flavor of the relationship of tactics and realization, here is an example adapted from Lockwood (1973), who examines the inflexional morphemes of Latin. "Forest" in Latin varies depending on the use the word is put to:

Nominative singular--silva  
 Genitive singular-- silvae  
 Dative singular-- silvae  
 Accusative singular--silvam  
 Ablative singular-- silvā  
 Nominative plural-- silvae  
 Genitive plural-- silvārum  
 Dative plural-- silvīs  
 Accusative plural-- silvās  
 Ablative plural-- silvīs

Other words vary likewise, but the change in endings depends on what class the word belongs to. The analysis results in Figure 8. (Note that at the phonemic level, a-i becomes ae, a: becomes ā, a-i:s becomes īs, and so on.)

The connection of the interaction experience and the semantic levels of language is accomplished through the association of the components of the semantic levels with various epistemes:

1. Gestalts--those sensations and actions which

Lexotactics

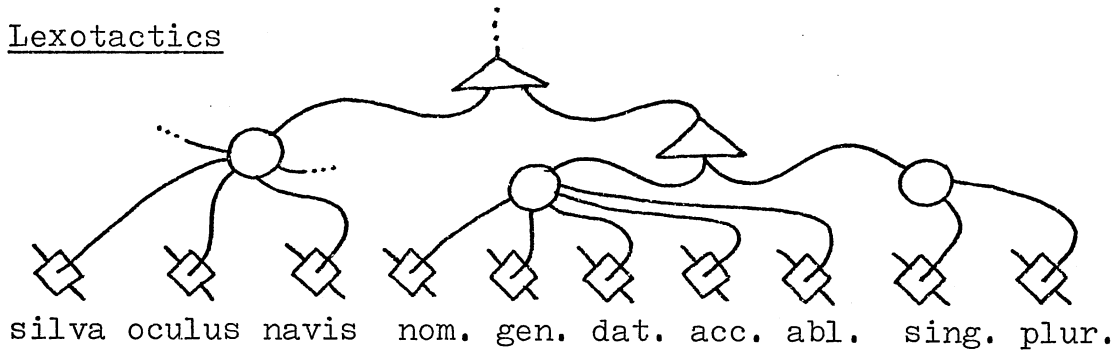

Realization (alternation pattern for inflexional lexons)

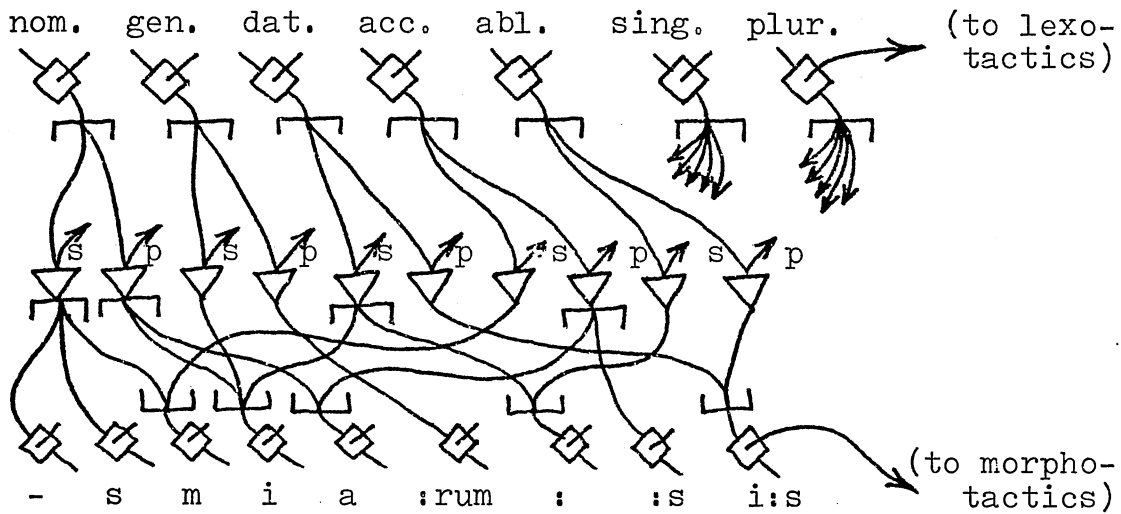

Morphotactics

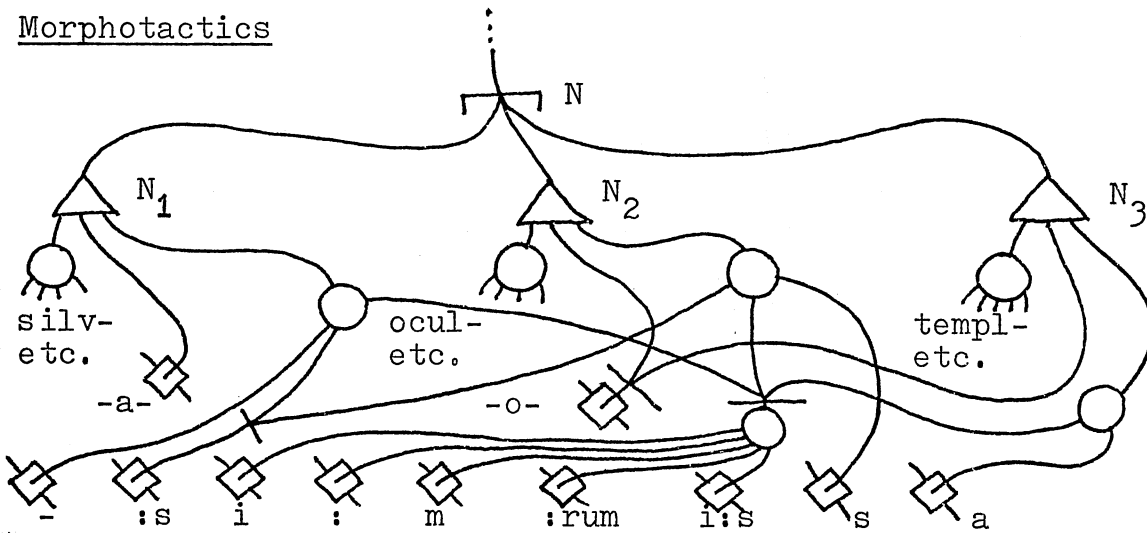

Figure 8. Lexotactics, Realization, and Morphotactics  
(adapted from Lockwood, 1973)

have integrity for the individual, i.e. objects and acts (e.g. John Smith, my walking, etc.).

2. Relations--the acts (or anticipations) the individual must perform to perceive (or do) more than one gestalt fully (e.g. he is next to that tree).

3. Aspects--that which is abstracted from a gestalt by an act (or anticipation), and which the gestalt shares with other gestalts inasmuch as the act (or anticipation) can be performed on them as well.

a. Modal aspects--that which is abstracted by a restriction of the sensory mode (e.g. green).

b. Temporal aspects--that which is abstracted by a restriction of the time over which the gestalt is dealt with (e.g. waving).

c. Spatial aspects--that which is abstracted by a restriction of the spatial range over which the gestalt is dealt with (e.g. nose).

So, what we have called components are essentially "named" epistemes.

left like this, language is a complex but somewhat mechanical translation system. What gives it life is the input from past experience. The very simplest presentation of this is the narrative: It consists of predications arranged hierarchically by means of the explicit or implicit relations between predications (e.g. conjunctions, causal connections, time spans, etc.), as illustrated earlier in Figure 7. The "components" of this narrative



network (the circle nodes) connect to the taxonomies which tie epistemes to the formal layers of language, as in Figure 9. The narrative is, of course, a story--the barest bones of a full representation of our past experience. But the difference is a matter of the degree to which we fill in the details.

### Semantics

The network diagrams are an effort to keep us firmly connected to the images of this metaphysics and theory, and language makes a nice demonstration of the descriptive power of the network. But language is more than just this: It is man's primordial logic, his most efficient means of manipulating events when reality itself cannot be manipulated.

Geoffrey Leech (1969, 1974) offers us an analysis of semantics as a system of logic. First, semantics operates with a number of components of various species:

1. Binary taxonomy--"alive" (+LIVE)/"dead" (-LIVE), "human" (+HUMAN)/"non-human" (-HUMAN);
2. Multiple taxonomy--"gold" (aMETAL)/"copper" (bMETAL)/"iron" (cMETAL)/...;
3. Polar oppositions--"large" (+SIZE)/"small" (-SIZE);
4. Relative opposition--"parent of..." (:PARENT)/"child of..." (-:PARENT), "own"/"belong", "over"/"under", "because"/"so that", "greater than"/"less than";

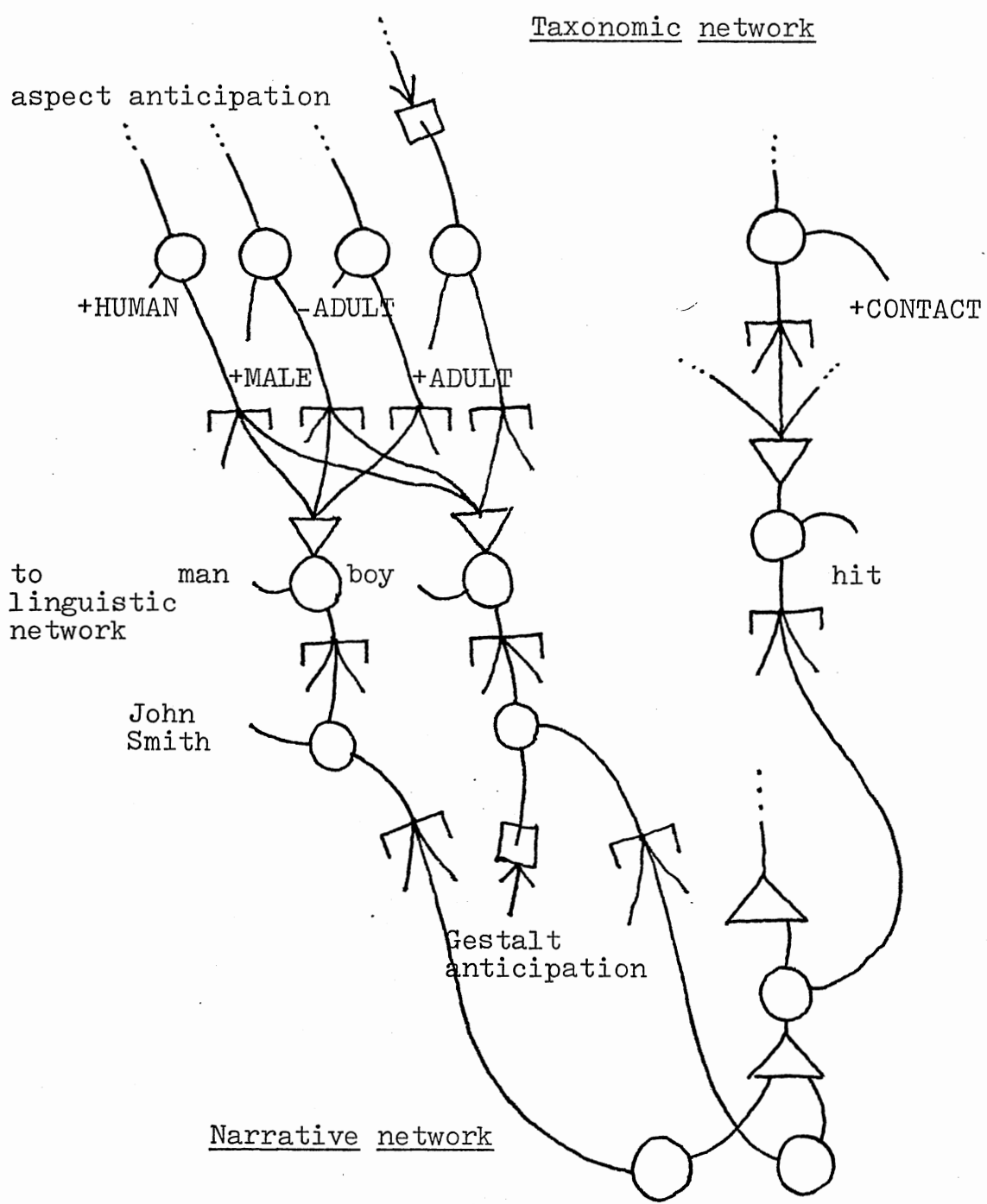

Figure 9. The Interaction of Narrative and Taxonomy

5. Hierarchy--"inch" (1LENGTH)/"foot" (2LENGTH)/  
"yard" (3LENGTH)/..., "Monday"/"Tuesday"/"Wednesday"/...

6. Inverse opposition--"possible" (+"POSSIBLE)/  
"necessary" (-"POSSIBLE), "allow"/"compel", "willingness"/  
"insistence", "become"/"stay", "universal all"/  
"existential some".

Note that we might reduce these to two forms: The binary taxonomy could be considered a limited form of the multiple taxonomy; the polar opposition could be considered a relative opposition wherein one argument is "understood" (e.g. "he is small" as "he is smaller than most people"); the hierarchy is a taxonomy which contains an implicit opposition; and the inverse opposition is an opposition which contains another, implicit, opposition.

Secondly, we gather our components into clusters: +HUMAN +MALE +ADULT is the argument "man" and +:DIRECTION +PRIMARY is the predicate "in front of." Then we arrange our clusters into predications: "The man (+DEFINITE +HUMAN +MALE +ADULT -PLURAL) was in front of (:DIRECTION +PRIMARY +PAST) the woman (+DEFINITE +HUMAN -MALE +ADULT -PLURAL);" "Alsations (aBREED +PLURAL) are large (+SIZE -PAST);" "It's raining (+RAIN)." These examples, incidently, also exemplify the three types of predication: two-place (or relational), one-place (or attributive), and zero-place predications respectively.

Thirdly, we have the relationships between predications, the logic of correct semantic

transformations. Note that, as Leech himself acknowledges, transformations disappear when put into network form; however, most of our thinking and our verbal expressions themselves are linear and transformations are essential when linearity is adhered to.

The rule of entailment states that "a relation of entailment arises between two assertions whenever (the assertions being otherwise identical) an argument or predicate in one assertion is hyponymous to an argument or predicate in the other" (Leech, 1974, p. 137). Hyponymy (or "meaning inclusion") is that situation where one cluster of components includes another. So "I saw a woman" entails "I saw an adult," and "I stole a horse" entails "I took a horse."

The rule of inconsistency states that "a relation of inconsistency arises between two assertions whenever (the assertions being otherwise identical) the predicate of one is incompatible with that of the other" (Leech, 1974, p. 137). Incompatibility is the presence of mutually exclusive components. So, "Mary dislikes work" is inconsistent with "Mary likes work," and "This is red" is inconsistent with "This is blue."

As part of these rules of transformation, we must be aware of certain semantic anomalies: Null arguments-- e.g. "The dinner was cooked (by someone)" or "John is eating (something)"--are superordinate to all other sets of components because they contain no features. So

"John eats nuts" entails "John eats." Selectional restrictions must also be allowed for: Often a predicate depends on a particular feature in one of the arguments. "The horse owns the man" seems incorrect because owns depends on a +HUMAN in the initial argument.

Further complications arise with embedding and down-grading predications. Embedding is using a predication as an argument in another predication: "John angers Bill" = "John makes Bill angry" = "John causes (Bill is angry)." Downgrading is using a predication as a feature: "A bewigged man" = "A man with a wig" = "A man (who was wearing a wig)."

Fourthly and finally, we have the logic of what Leech calls formators: "Roughly: features of meaning whose function is purely internal to the linguistic, i.e. logical, system" (Leech, 1974, p. 161). This definition includes "not", "and", "or", "the", "some", and "all" (or at least their non-referential components).

It is from this stuff--ordinary language--that the great systems of "formal logic" were essentially derived, and with which they will always be judged.

Sound is easily detached from its source, and easily intrudes into other events; a creature with good hearing, flexible vocal apparatus, and a brain capable of generativity, would find this peculiarity of sound a great aid to survival. Language is a practical compromise between presenting others with a fully detailed

reproduction of an event and not presenting them with anything at all. We attempt to extract generalities from an uncertain world in order that we may lessen these uncertainties for ourselves and others. Language is a model of reality.

We have discussed the "formal" model of the network, and the "casual" model of everyday semantics. Let us now go on to how we go about arriving at a description at all.

## CHAPTER V

### METHOD

A society's culture consists of whatever it is one has to know or believe in order to operate in a manner acceptable to its members, and to do so in any role they accept for any one of themselves. . . . It is the forms of things that people have in mind, their models for perceiving, relating, and otherwise interpreting them (Goodenough, 1957, pp. 167-168).

We can see that a large part of a person's life in the world, in his society, or even in his own mind, is a matter of skills. Although most of these skills operate quite unconsciously, still we must attempt to allow the people in whom we are interested to themselves provide the terms of the descriptions of their skills. With care, I believe, these skills may be brought to light.

Imagine a world consisting of a crystalline forest. Billions of crystals form, grow, break, and form anew. Each crystal, although bearing some resemblance to other crystals, is unique. The reason for this uniqueness is that each crystal grows in a pattern determined by the images falling on its surface, including the images of its fellow crystals and the reflections from their surfaces of itself and others. If you wish to study these crystals, by all means do so; But keep in mind that the

very act of observing them contributes to their uniqueness.

Certainly, we can go a level-of-analysis down, where, presumably, this "uniqueness principle" is less pervasive. We may even be able to predict and control events at this level, and perhaps explain what happens at our original level. But, beyond the set of axioms we might derive as defining "being crystalline," the crystals themselves remain unique and cannot be used to discover further laws. The social psychology of these our fabulous crystals is an historical science.

How does the unfortunate social psychologist then deal with his subject matter and get it down on paper? One way is to derive from your theory an hypothesis, define your operations, manipulate two or more groups differentially, and statistically examine the results. But this method was designed to produce law, and is inappropriate in direct proportion to the generativity (historicity) of the subject matter.

Those more aware of historicity have been forced (often under protest) to use observational methods. In the theory here presented, however, the legitimacy of observation is upheld as allowing for the description of the decisions the observer uses in anticipating the generative creatures he observes. The resulting description can be tested by being used by others to anticipate within the same or similar events. And it may be replicated by another scientist and the descriptions



compared.

The danger of observation lies in the fact that an error might not be discovered until well after the possibly long and arduous field study is completed--if at all. A single component absent during the period of observation may make the resulting description applicable to only some specific events (for example, "when dealing with outsiders"). Although we may attempt to cover for this prospect by purposely seeking deviant events, in general non-experimental methods suffer in effectiveness when used in the "do-then-analyze" manner of the experiment.

One solution requires that we test our anticipations repeatedly during our observation. Even better, we might test our anticipations continually, throughout our observation by allowing them to become acts. This is called passing.

Just about anyone who has moved from one culture to another, given sufficient time, will learn enough about the new culture to pass as a native (or a reasonable facsimile thereof). As we all know, children are especially adept at this. Some members of socially defined minorities spend half their days in their own culture and half in the dominant culture. Transvestites and, even more dramatically, transsexuals are quite capable of passing as a member of the opposite sex. Actors present us with convincing imitations of people, cultures, moods,

and so on. Forgers make their livings painting as if they were Rembrandt, Picasso, or Renoir. Impressionists go so far as to "pass," however briefly, as individual celebrities. In passing, the scientist need only remember to write down how he does it.

Unfortunately, society makes certain demands of us, and we are seldom allowed the pleasures of spending the necessary amounts of time on a specific culture, group, or individual. So we must often turn to abbreviated methods:

1. As I have already mentioned, we can forego the continuous growth of passing and instead record the decisions we make in anticipating (i.e. we can observe).

2. We can study what we already know, i.e. we can introspect about our own lives, societies, and cultures--risking the errors of idiosyncrasy (who will dare test our descriptions?) and blocking (we must force ourselves to be aware of what we already know).

3. We can narrow our range, from complex, intact, long-term events to simple, isolated, short-term events--possibly ignoring the contributions of context.

4. We can withdraw from subjects and events, going from, say, participant-observation to double-blinds, recorded instructions, and tachystoscopes--risking mistaking the lack of resolution contributed by distance for error.

5. We can increase the occurrence of some event by

manipulation, for example by presenting subjects with anomolous events (as in Garfinkling), or by controlling extraneous stimuli (as in the laboratory)--possibly creating a self-fulfilling prophecy.

6. We can rely on "secondary sources"--verbal or written material such as biographies, speeches, etc.--with the simple risk that what people say may not be what they mean.

7. We may ask our subjects for the decisions they make, allowing them to do our work for us, as we do in ethnoscience and interviews, as well as questionnaires and surveys--risking misunderstanding, rationalizations, and over-attention to idiosyncrasies.

Please note that each simplification has its justifications, and only God knows when we lose more than we learn. But I do make one heretical point: "The Experimental Method" is just one of a large number of less-than-perfect methods; And passing and other qualitative methods are not weak imitators of laboratory experimentation, but rather methods appropriate to the historical nature of human experience.

Historicity isn't discontinuous with the mechanistic viewpoint: The greater the number of variables, the broader the chunk of space-time, the deeper the layers of stratons you need to take into account in order to predict and control within a certain probability range, the more you are dealing with historicity. The traditional

conception of scientific methodology does not hold up well when things get too small, too large, or too complex. In passing, there is no attempt to Understand, Explain, Predict, and Control in the sense that these are thought of as "something special." Instead, passing aims at understanding, explaining, predicting, and controlling as we do in day-to-day life, that is, as anticipation-sensation-adaptation-and-action. By growing towards comprehension, rather than arriving at lawfulness, thus do we handle our historicity.

## CHAPTER VI

### IN THE WORLD

Although the preceding chapters may occasionally suggest a concatenation of nonsequiturs, I hope the essentially visual image that underlies the less fluid verbal description has been made clear. But, rather than apologize for my short-comings, allow me to introduce the following sections, concerning the realization of these often airy abstractions upon the real world. In the form of a series of excerpts from a fictional diary, each piece is intended to exemplify portions of earlier chapters. The comments which follow go on to briefly indicate positions on various general issues as they derive from the "glass beads" world-view.

#### Beginnings

The rain came sheeting down, turning the lush green jungle into corrugated cardboard. Each step was a matter of pulling a foot smacking from the mud. I trudged on in the direction I had been taking since being left off at the river dock some two hours ago. Close to despairing of ever finding the Monara village, nothing could have pleased me more than when I heard the continuous resounding of

pistol shots: The rain hitting bamboo roofing. Seemingly hours later, I was face-to-face with bamboo wall gently curving away in either direction. I randomly chose one and followed the wall, listening to the chatter of children within. Suddenly, the wall ended and I stumbled into that single circular hut that was the village of Monarakombei.

The villagers had been conversing under the roof extending from the outside wall, loudly so as to be heard above the downpour. But with my entrance, a hush spread around the 400 foot diameter circle like a wave. Some boys who had been wrestling in the mud of the central commons scurried to the shelter of their respective families' segments of the village. The heads-of-households left their hammocks, collected their machetes, and slowly moved into the rain, toward the intruder at the open gate. Pulling myself somewhat unsurely together, I fidgeted in my sopping pockets for my flashlight. When I had it in hand, I straightened into the "posture of strength" I had learned from the town guides, and played the light around the commons. The townspeople who occasionally traded with the Monara had long ago learned that, unless a stranger demonstrate that he had tiganaia--"power"--his strangeness would make him akaimonara--a non-human in human shape, a demon, an object to be freely disposed of.

As uncertain of how to deal with me as I was of them, they scrupulously avoided dealing with me at all, even in making eye contact. Instead they concentrated on the

flashlight that had quickly left my fingers. Other than those trade goods--machetes, knives, iron pots, and the like--that they traded skins, feathers, and exotic foodstuffs for, the Monara rarely see anything so exotic as a flashlight.

Some began walking back to their homes; others were rapping on my backpack. Fearing that I would be left standing in the rain due to lack of interest in anything but my possessions, I spoke in the town-village pidgin: "I am Monara!" This was apparently so patently absurd to them that it caused quite a stir all around the compound. After some discussion among the older observers, presumably concerning who would "have" me, and indeed whether I was worth having at all, I was led off to the far segment of the circle by two teenage boys--with machetes drawn.

They indicated that I should sit, and facing me an older man sat as well. I squared my shoulders and repeated: "I am Monara!" The man grinned broadly and said "Karane woni kopaia," then "Semane ia monaketa wa?"-- "Perhaps a child," then "Do you have any tobacco?" My education had begun.

### Commentary

Here then we begin, with passing in its ideal form. Our hero is learning to be "human" once again, this time taking notes. Certainly, there will be gaps in his

knowledge (in inverse proportion to the time and effort he puts into becoming a Monara), but knowledge of something as complex as a society--or a single human being--is never complete. Furthermore, whatever "abbreviations" we choose to use in our research, we must choose in full awareness of what we may lose as well as what we stand to gain.

### Relationships

Kaneiro told me something interesting one day: Thirty-seven years ago, a large minority of the village headed southwest after bitter and prolonged disagreements with the majority over tree rights. Some 20 to 25 miles away, they made camp and established their own village. Since then, the village has repopulated itself and, indeed, Kaneiro fears it is becoming again so crowded that tempers flare ever more frequently. He says that, in the "old days," the village had been more careful about the number of children born each year (the "birth control device," I fear, being infanticide).

I asked him why they did not expand the village circle, or build new circles nearby. With the tools they had traded for they had already substantially increased the harvest from the surrounding fruit-tree forests, as well as raised the fresh meat quota significantly.

He seemed surprised at my ignorance. He explained: "If you are two people, you have one naikam (reciprocal kinship relationship). If you are four people, you have



six naikami, and they might further ally two against two or three against one. The more people in the village, the more difficult it becomes to assure proper behavior in all circumstances."

I asked him why, then, his village didn't split more often, perhaps even breaking into small groups of five or ten people apiece? "Because," he answered, "there would then be no village. The village is not the people, though they are necessary to it; The village is the naikami. If you have no nephews, you cannot be an uncle; If you have no village, how can you be a man?"

#### Commentary

Although hardly a simple sum, the behavior of a collection of individuals depends on these individuals. This is not to say, however, that the differences between a group and a society is one of sheer numbers: In a dyad, we have two people and one relationship; In a society, the relationships so far outnumber the individuals that the "illusion" of the transcendent existence of the society beyond the individuals which compose it arises. "Illusion" is used very loosely indeed, and should remain in quotation marks: This "illusion" is dealt with by individuals as quite real, as is brutally exemplified by warring nations, castes, and races, and more pleasantly by the families and communities which help to define the individual's existence.

Between the dyad and the society come various other human organizations. Harmonious functioning of an organization depends on the degree to which the members of that organization share a common grammar of interactions (what social psychologists have been pleased to call roles, responsibilities, status, norms, modes of access, etc.). Harmonious integration of an individual into that organization depends further on the degree to which that individual's personal patterns are compatible with the patterns that others expect him to exhibit.

#### Father

I knew that "father" in Monaram isn't the same as "father" in English: It includes, for example, your father's brothers; And it involves different obligations and rights in relation to the son or daughter. But I made a mistake in assuming that "father" was a single, concrete role that one enters upon having a child.<sup>1</sup> A father is one's immediately senior kinsman. This entails, automatically, the passing-on of ancestral relations and right of inheritance. It also prescribes the duties of providing for the child without expecting reciprocation. There are other things a father usually does which I had thought to be part of the role as well, exceptions being just that: exceptions. For example, responsibility for

---

<sup>1</sup>This section on the components of fatherhood, including the example of an exception, is adapted from Keesing (1970).

the child in cases involving compensation for damage done by the child, as well as control over the marriage of a girl child, appeared to be a father's lot. Another area of fatherly concern is in the household: discipline, labor arrangements, and additional sustenance for which he could demand repayment.

But there are many exceptions: A child who has lost his father may be adopted by an uncle, who takes responsibility as head of the household, yet the child may be legally represented by another relative. Or a child with a living father may be disciplined by his grandfather.

My discomfort with these exceptions was resolved when I investigated one such case in detail. When a young girl, Kemala, lost her father, she was taken in by a distant relative named Omai. As head of the household, he took care of her sustenance, work, discipline, and so on, as well as the more tender fatherly duties. Another, closer kinsman, Talu, acted as her guardian in legal matters. She left Omai's household when he approached her sexually, and later married. Her bridewealth was distributed among her immediate relatives by Talu--but Omai received nothing. Omai sued Talu for recompensation for his care of Kemala, and Talu came back with a suit demanding recompensation for the sexual insult to his ward. Each wound up paying the other an approximately equal amount.

Here is the key: Omai felt that, since he had adopted the fatherly role, he should be considered her immediate relative. Because of the insult, Kemala refused to recognize him as such, considering him the head of the household only. This, however, made her liable for repayment of the sustenance Omai had provided. There are three separate components to "father" which, though usually taken-up by one individual, may be distributed, as circumstances dictate, among two or three relatives.

Some time later, I asked Talu whether all these rules for behaving properly with others didn't stifle spontaneity and make their lives dull and predictable. "Hardly!" he answered, "Although I can rely on my brother to be a brother to me, and a father to his children and a son to his parents, I cannot tell what he shall do with his day. Knowing the rules of a game doesn't make it too dull to play!"

#### Commentary

As a theory of individual differences, "glass beads" generates neither a trait nor a type theory. The infinite potential cognitive structures (not to mention their constant interaction with the infinite potential variations of situation) cannot be laid out along preconceived dimensions; Neither is it terribly useful to talk of categories when these categories include but an individual apiece.

But, culture is essentially those patterns shared by most (if not all) of its members, and a culture is defined by the decisions one needs to make in order to pass as a member of that culture. Just so, categories and dimensions of personality are constructs developed by the culture, society, and individuals concerned, and are defined by the decisions one needs to make in order to pass as an individual so described. Four observations from an exceptional article by Keesing (1970) expand on this conception:

(a) Children learning their culture--like ethnographers learning someone else's--learn the typical and standardized patterns first, and gradually learn the exceptions to "rules of thumb" and "ideal roles."

(b) Our consciousness of "role playing" is largely confined, first, to the typical labeled composite "positions" of our culture, and second, to positions of higher levels of taxonomic hierarchies (like "physician"). Intuitively we apparently perceive the lower-level implicit "positions" as patterns of acts (like giving the bride away) rather than capacities in which we act.

(c) The composite "positions" in which we ourselves and those close to us habitually interact become particularly standardized in our conceptual world. But each of us also continually encounters alters who represent unfamiliar or unlikely composites, and we must behave appropriately toward them.

(d) Since only the low-level "position" elements in these composites have invariant behavioral entailments--that is the way we identified them--we either must pay serious attention to them descriptively or abandon the assumption that occupying a position entails a predictable role (Keesing, 1970, p. 433).

## The Chief's Son

Here's an interesting children's tale:

"Moglala, the chief's son, wished to marry. His father arranged with his friend, the chief of a neighboring village, that Moglala meet each of his three daughters, to see which he would prefer. Moglala said 'I am always pleased with myself, and have spent many hunting trips alone and never suffered for lack of company. Give me the one most like myself, so that we need never disagree.' So the two chiefs left him with the oldest daughter, Naru, who was most like him.

"Well, the first day they spent joyfully recounting what they liked and disliked, and agreed at every point. The next day, they delighted each other by saying the same things at the same time. By the end of the week, however, they both sat quietly in opposite corners of the hut. Because each was so like the other, they had nothing left to say. Each knew the other so well that they spent the time as profitably thinking to themselves as talking to each other.

"Moglala went back to his father and said 'Naru will never do. I see now that never disagreeing is very dull indeed. Give me instead, father, the one least like myself, so that we may always surprise each other and talk of many different things.' So his father and the other chief left him with the middle daughter, Kelam, who was

least like Moglala.

"The first day they told each other stories that neither had ever dreamed. And the next day they invented a game where each must never do what the other expected. But by the end of the week, they both sat in opposite corners, glaring at each other: They were so different that one often spoke of things the other didn't care for, and frequently broke into argument, often over minor things.

"Moglala returned to his father's hut in despair. He said, 'Father, I fear I shall never find a wife and marry. I have been with a woman very like myself, and was bored. I have been with a woman very different from myself, and was angry. If I could not be happy with either of these two, certainly I could not be happy with any woman, as she must be a combination of both, and so both bore me and anger me!' His father suggested that Moglala try once more, with the youngest sister, Gani.

"Now Gani, knowing of her sisters' failures with the chief's son Moglala, saw little chance for herself. On the first day, Gani and Moglala spoke some: Sometimes they bored each other; sometimes they angered each other. The second day went much the same way, and Moglala wondered whether he should return to his father, for certainly such a mediocre beginning would go nowhere.

"But he remained, and found, to his surprise, that during the days that followed, they sometimes agreed,

sometimes disagreed, and often enjoyed happy conversation. He saw that, as the fruit grows best when the trees are neither too far from each other nor too near, so will two people be happiest when they grow neither too distant nor too close. So he returned to his father and announced that he and Gani would marry."

### Commentary

Irritation and pleasure were defined as the experiential aspects of ineffectual interaction and the increase of cognitive organization respectively. The frequency and degree to which any individual experiences irritation or pleasure (of the cognitive sort) depends upon his structure and his situation and, of course, their interaction. When two individuals interact, the scheme becomes complicated indeed: The degree to which continued interaction is more pleasant than irritating for either person is determined by the degree to which the other provides for continued increase of cognitive organization without overly straining the ability to anticipate and adapt effectively. This applies as well to an individual's relationships with such social complexities as a job: A certain amount of "irritation"--i.e. challenge--must be present for the individual to gain pleasure in resolving that challenge, given that one is not plagued by the more demanding irritations of basic human needs (a la Maslow) and that the challenge is within the powers of that person



to resolve.

The reader may find this commentary a common-place, and indeed one finds discussions of "growth in marriage," "leaving spaces in your love," and "the golden mean of job satisfaction" in the advice columns of any number of tabloids. The reader might ask himself, however, if it is not a valuable achievement for a social-psychological world-view to be able to comfortably accommodate the common-place.

#### Blessed Resolutions

There are three or four degani or "double-souled" men in or near the village. One of these, Parenamenam, is especially interesting in that the villagers are particularly aware of the aetiology of his degani-ness. As I have indicated before, the Monara have a rather different conception of incest than we do: A child's riddle goes "Where grows the sweetest grass?--below your sister's belly!" Rather than being considered naturally repugnant, incest is for the Monara something each must fight continually against. The participants in an incestuous relationship essentially enter into a number of conflicting "roles" in reference to their own family, which has the more real effect of depriving them of a means of interacting socially with their family at all. In most cases, the woman remains with the family in a slave-like status (makaira), where the resolution of

conflicting roles consists of adoption of the lowest female role--complete lack of status. This has a functional similarity to the retreat of some young women into convents as a response to social indiscretions, as was common in medieval and early modern Europe. The makaira greets any family member by falling on the ground with arms and legs tucked tightly beneath her. There are two such makairi living in the village. The male participants, however, cannot adopt this course as it only adds one further conflicting role component--"femaleness." In most cases, the man simply runs away. The intensity of the conflict is perhaps indicated by the fact that, in the three cases the villagers could recall, two were found within a month of leaving, dead from self-neglect.

Parenamenam, then, committed incest with his father's older brother's son's daughter (enaira, "sister"), who was as well his ward. Just to give a bare indication of the conflict of role-components, he would have been obliged to retain the joking-relationship with his brothers while at the same time adopting the formal relationship, wherein joking is a cause for family vendettas, of the potential brother-in-law. This aside, Parenamenam, when confronted by his male relatives, responded not with any of the many conflicting greetings (any one of which would have been insulting), but with the spontaneous behaviors of the degana: If one responds to a social situation with a behavioral episode not used in social situations, one is,

by definition, non-human (akaimonara), and may be suffered to remain at camp, or killed at the family's discretion. The trick to remaining "double-souled" is to never, under any circumstance, behave in a socially grammatical manner. To do so would indicate to others that you are again monara and so accountable for insult.

Parenamenam, along with the other degani, fills a niche in the Monara village by providing a source of amusement for both children and adults, imitating monkeys, chickens, and so on, as well as presenting surprising, totally inappropriate human actions, such as breaking wind upon receiving a gift of food. Other than being rather ill fed (he lives on handouts and garbage) and very dirty, he appears to be in good health. The curandero will not attempt to aid him or the others: Degani-ness is considered a "blessed" resolution of such deviations as incest.

### Commentary

The violation of general social interaction rules by certain individuals is "irritating" to those--the "general public"--who accept these rules. The irritation may be dealt with in a number of ways, depending on the culture, society, and individuals involved, including removing the offender (ostracizing, imprisoning, or killing), changing the offender (treating, beating, or silencing), and making an institution of the offender (as shaman or clown). All

of these methods are accompanied by an attempt to find a place for such people in the shared structures of the community, usually by labeling the offender. The label may be based on the rules which have been broken (e.g. "adulterer"), the means by which they were broken (e.g. "sodomite"), the means used to resolve the situation (e.g. "prisoner"), the assumed aetiology of the offense (e.g. "deranged"), or most likely a combination of all of the above. A review can be found in King (1979).

To speak of labels and roles in this manner has an unfortunate side effect: It begins to look as if the individuals carrying such labels as "mentally ill" or "antisocial" are simply wearing masks, put on by society or by themselves--personas devoid of affect. But you will recall that the irritations of poor anticipations can rise to terror, and that anticipations can conflict with each other as well as with the outside world. For example, leading to (or deriving from) a label of mentally ill may be a desire to both leave and stay at home, or a conflict between your image of yourself and what others communicate to you, or an incongruence between the "rational" and "affective" aspects of your interaction. But the range of affective experience of those labeled as mentally ill is the same as the range "permitted" those who are not.

#### A Problem of Semantics

Since the Monara spend half their lives swinging in

their hammocks, I decided to check their understanding of pendulums. As expected, they were well aware of the relationship of frequency to the length of the string. But I was quite surprised when they all insisted that pendulums with heavier weights were faster than those with lighter weights! I proceeded to "educate" my friends by demonstrating patiently how, given a specific length of string, the speed is a function of only the height of the arc. They agreed, as long as I stuck to one weight, but persisted in their belief, so I demonstrated again with different weights, with the results I had anticipated. But they insisted that I was mistaken! I became somewhat excited and began yelling "Can't you see it? Can't you see?" At this, Balorum struck me hard in the chest and said, "Can't you feel?"

It dawned on me that this was a "communications" problem. So I explained my conception of speed to them, in terms of how many heartbeats it takes to get from the entrance of the village to the far segment. After some discussion among themselves, Balorum spoke: "If a water buffalo took five heartbeats to cross the commons and a bee took five minutes, which would you prefer to stand in front of?" With this I understood what he had meant when he asked if I could feel. They have a conception of distance, but not of small, fixed intervals less concrete than heartbeats, hence no speed. Likewise, they apparently did not extract speed from their concept of force: One

man's arrows do not go faster than another's; he has a better draw.

Discussing this further with Balorum and his brothers, I began to realize that even weight was thought of in terms of force: Since all objects "want" to fall, holding a stone is the same as stopping a stone from continuing on a trajectory it "wants" to take. When a stone falls from a height, well, obviously it increasingly wants to get to the earth, i.e. it accelerates! This sounded vaguely like a lecture I had heard some years ago on relativity. But whether Einstein would agree or not, this revelation went some way towards correcting my usage of the word ugalam, which I had assumed meant both speed and weight. I no longer commented on the great "weight" of resting rocks, nor on the enormous "speed" of the local mosquitos! I suppose that, living in a rather thick rain forest, people here had little opportunity to track things over long distances, the sort of thing that makes speed obvious. On the other hand, falling objects and surprise collisions with frightened animals are quite common.

#### Commentary

The reader will recall, back in the section on language, I distinguished between the "mechanical translation system" of semantic knowledge, with its neat little taxonomies and rigid little rule systems, and our "experiential" knowledge, strung out in inefficient

narrative nets. The first may be thought of as the individual's version of philosophy, science, logic, and mathematics, the second as history. The point is that an individual's beliefs, a commoner's common sense, an esoteric culture's folk science, and a scientist's well-developed science are all of the same cloth: They are all attempts at expanding our semantics by way of experience in order to reduce the irritations of the unexpected.

This formulation of knowledge has also been the basis of much research into cognitive development. Development consists of new structures built upon old structures when old structures fail to perform (learning), as well as the growth of innate structures (maturation), and the interaction of the two. Inasmuch as most learning occurs in small pieces, we expect growth to be a cumulative, long-term process. But, as this is a qualitative theory, learning does not follow the elegant curves of the statistician, and indeed one small piece of new knowledge may be just the one to allow the structure to fall together into what appears to be a wholly new orientation. Baron (1973) has made a very similar suggestion, using componential analysis as an alternative to Piaget's and Kohlberg's stage theories.

#### The Curandero

Two men ran into the curandero's hut bearing a young woman between them. A snake had entered the compound and

she had had the misfortune of stepping on it. The old man had them lay her on his cot and set straight to his work: Happily, his first step was to suck at the wound. After each draw, he spat the blood and venom into a small stone cup. After some five minutes at this arduous task, he stopped, examined the wound, and reached for a leather bag suspended from the roof near his cot. He applied an ointment from the bag and bound the wound tightly with a woven grass bandage. I assumed that this was the end of the matter and that he would send them home with the woman with a prescription of roots and rest. But instead, he bent over the feverish woman's ear and whispered, "What sin did you commit?" The woman moaned and began to cry. By then, some thirty people, family and friends, had gathered around the curandero and his patient. He struck her feet with a small but sturdy stick. Again, he demanded to know her sin. At last, she spoke out: "I stole my sister's taro!" The curandero shouted some unintelligible phrase, spilled the contents of the stone cup on the ground, and told her that she could rest. She collapsed into sleep.

I spoke with the curandero the following day, and asked him why he had treated the woman so. He asked me why I thought the snake had bitten her. I was non-plussed when I realized that there was no word for chance in their language. The old man explained that the snake's bite allowed her to confess a sin that he knew had troubled her



for many months. Without this opportunity, he felt that she would have slowly deteriorated from the withheld evil. The snake saw fit to punish her and so allow her to be well. As the ancient Greek sophist used his rhetoric to allow others to come to his conclusions by themselves, so the curandero saw the means for her to cure herself of guilt in a snake's bite! I was appropriately grateful for his teaching and left him a chicken in payment.

### Commentary

We might conceive of teaching as "applied passing:" Discover how others think and how you would convince yourself if you thought as they do, and then proceed to convince them. In therapy, we might present the patient with an image of himself so that he may be aware of himself more fully; Further, we might "become" the patient and carry on a "monolog" with him, directing his thinking with his own logic, providing little more than the "motivation" which comes easier to the outsider. Even in dealing with the physical world, we might educate ourselves by the "practical animism" of becoming the problem.

Although oriented to understanding, this thesis does not rule out prediction and control: Rather, it acknowledges the complexity of human experience and so avoids presenting those in authority with easy solutions to their problems. The theory implies that, in order to predict and control people effectively, you must be in

control of a large number of variables and know more about the relationships of these variable than your subjects.

As Neisser suggested (1976), the chess master beats me because he knows more about chess, not because he knows more about psychology.

We may also find a form of prediction and control, requiring less offensive differentials in power, in education. The original sense of the word involved educating, persuading, seducing, arranging that others come to your conclusions by their own logical processes, and the ethics of this are far from pristine. But education as the providing of alternatives differs essentially from prediction and control in their more authoritarian modes by stipulating that the steps in your direction are freely taken. Remember that this paper has allowed for will as the ability to separate our internal image-making from environmental goings-on: In honest education, the individual, when presented with the information, may at any time say no.

#### Endings

When I prepared to leave with the next trading expedition from the town down-stream, I had been with the Monara eighteen months, the last five as a Monara: Padam, the old man who first spoke with me, had taken me into the Taro clan as his adopted son. This was done in consultation with the various family headmen, who

evaluated my education and concluded that I was now capable of behaving as a kinsman without unduly insulting them. I was going to miss them, and I left with a promise to return in five years, if I could.

With the expedition had come my brother and his wife. I ran to them, hugged them, and rapped them on their shoulders. A look of consternation on their faces momentarily upset me, but my joy at seeing them put it out of my mind. Only later did they explain: What they had seen running down the dock in bare feet was a wiry brown man wearing nothing but a loin wrap and hair pasted back with red mud. They had not immediately recognized this Monara tribesman as their brother.

#### Concluding Remarks

How can we reconcile Piaget's developmental work with behavior modification, Freudian defenses with information-processing models of cognition, split-brain research with theories of motivation, existential dilemmas with industrial psychology, social psychology with day-to-day life? This paper is a step towards finding the "deep structure" underlying these diverse surface manifestations, a step towards providing a context within which these and other aspects of the sciences of human experience may find integrity.

## BIBLIOGRAPHY

- Altman, I. Environmental psychology and social psychology. Personality and Social Psychology Bulletin, 1976, 2, 96-113.
- Baron, J. Semantic components and cognitive development. Cognition, 1973, 2, 299-317.
- Berlin, B., Breedlove, D. E., & Raven, P. H. Covert categories and folk taxonomies. American Anthropologist, 1968, 70, 290-299.
- Blumer, H. Symbolic interactionism: Perspective and method. Englewood Cliffs, N.J.: Prentice-Hall, Inc., 1969.
- Burke, K. The grammar of motives. N.Y.: Prentice Hall, Inc., 1945.
- Burke, K. The rhetoric of motives. N.Y.: Prentice-Hall, Inc., 1950.
- Chomsky, N. Aspects of the theory of syntax. Cambridge, Mass.: M.I.T. Press, 1965.
- Culbertson, J. T. The minds of robots: Sense data, memory images, and behavior in conscious automata. Urbana: University of Illinois Press, 1963.
- De Broglie, L. In P. A. Schilpp (Ed.), Albert Einstein: Philosopher-scientist. N.Y.: Harper Torchbooks, 1959.
- Filstead, W. J. (Ed.). Qualitative methodology: Firsthand involvement with the social world. Chicago: Markham Publishing Co., 1970.
- Gadlin, H. & Angle, G. Through the one-way mirror: The limits of experimental self-reflection. American Psychologist, 1975, 30, 1003-1010.
- Gardner, H. The quest for mind: Piaget, Levi-Strauss, and the structuralist movement. N. Y.: Knopf, 1973.

- Garfinkel, H. Common sense knowledge of social structures: the documentary method of interpretation. In J. M. Scher (Ed.), Theories of the mind. N.Y.: The Free Press, 1962.
- Garfinkel, H. Studies in ethnomethodology. N.Y.: Prentice-Hall, Inc., 1967.
- Gergen, K. J. Social psychology as history. Journal of Personality and Social Psychology, 1973, 26, 967-976.
- Gibson, J. J. The senses considered as perceptual systems. Boston: Houghton Mifflin, 1966.
- Goffman, E. The presentation of self in everyday life. Garden City, N.Y.: Doubleday and Co., 1959.
- Goffman, E. Encounters. Indianapolis: Bobbs-Merrill, 1961.
- Goffman, E. Strategic interaction. Philadelphia: University of Pennsylvania Press, 1969.
- Goodenough, W. H. Componential analysis and the study of meaning. Language, 1956, 32, 195-216.
- Goodenough, W. H. Cultural anthropology and linguistics. In P. L. Garvin (Ed.), Monograph Series on Languages and Linguistics No. 9. Washington, D.C.: Georgetown University Press, 1957.
- Goodenough, W. H. Description and comparison in cultural anthropology. Chicago: Adine Publishing Co., 1970.
- Hammel, A. (Ed.). Formal semantic analysis. A special publication of American Anthropologist, 1965, 67, part 2.
- Harre, H. & Secord, P. F. The explanation of social behavior. Totowa, N.J.: Littlefield, Adams, and Co., 1973.
- Harris, R. J. This is a science? Social psychologists' aversion to knowing what their theories say. Personality and Social Psychology Bulletin, 1974, 1, 1-3.
- Harris, R. J. The uncertain connection between verbal theories and research hypotheses in social psychology. Journal of Experimental Social Psychology, 1976, 12, 210-219.

- Heisenberg, W. Physics and philosophy. N.Y.: Harper and Brothers, 1958.
- Hesse, H. Magister ludi (R. Winston and C. Winston, Trans.). N.Y.: Holt, Rinehart, and Winston, 1969. (originally published, 1943.)
- Hjelmslev, L. Prolegomena to a theory of language (F. J. Whitfield, Trans.). Madison: University of Wisconsin Press, 1961. (Originally published, 1943.)
- Ikegami, Y. The semological structure of the English verbs of motion. Tokyo: Sanseido, 1969.
- Ikegami, Y. A stratificational analysis of the hand gestures in Indian classical dancing. Semiotica, 1971, 4, 365-391.
- James, H. A portrait of a lady. N. Y.: The Modern Library, 1909.
- Katz, J. J. Semantic theory. N.Y.: Harper and Row, 1972.
- Keesing, R. M. Toward a model of role analysis. In Naroll, R. & Cohen, R. (Eds.), A handbook of method in cultural anthropology. Garden City, N.Y.: The Natural History Press, 1970.
- King, S. B. Unpublished manuscript, 1979.
- Kuhn, T. S. The structure of scientific revolutions. Chicago: University of Chicago Press, 1970.
- Lamb, S. M. The sememic approach to structural semantics. In Romney, A. K. & D'Andrade, R. G. (Eds.), Transcultural studies in cognition. A special publication of American Anthropologist, 1964, 66, part 2.
- Lamb, S. M. Kinship terminology and linguistic structure. In Hammel, A. (Ed.), Formal semantic analysis. A special publication of American Anthropologist, 1965, 67, part 2.
- Lamb, S. M. Epilegomena to a theory of language. Romance Philology, 1966, 19, 531-573. (a)
- Lamb, S. M. Outline of stratificational grammar. Washington, D.C.: Georgetown University Press, 1966. (b)

- Lamb, S. M. Linguistics and cognitive networks. In Garvin, P. L. (Ed.), Cognition: A multiple view. N.Y.: Spartan Books, 1970.
- Lane, M. (Ed.) Introduction to structuralism. N.Y.: Basic Books, 1970.
- Leech, G. N. Towards a semantic description of English. Bloomington: Indiana University Press, 1969.
- Leech, G. N. On the theory and practice of semantic testing. Lingua, 1970, 24, 343-364.
- Leech, G. N. Meaning and the English verb. London: Longmans, 1971.
- Leech, G. N. Semantics. Baltimore: Penguin Books, 1974.
- Leech, G. N. & Pepicello, W. J. Semantic vs. factual knowledge: An experimental approach. Papers from the symposium on limiting the domain of linguistics. Milwaukee: Linguistics Department, University of Wisconsin, 1972.
- Levi-Strauss, C. Structural anthropology. N.Y.: Basic Books, 1963.
- Lockwood, D. G. Introduction to stratificational linguistics. N.Y.: Harcourt Brace Jovanovich, 1972.
- Lockwood, D. G. The problem of inflexional morphemes. In Makkai, A. & Lockwood, D. G. (Eds.), Readings in stratificational linguistics. University, Alabama: University of Alabama Press, 1973.
- Lounsbury, F. G. A semantic analysis of Pawnee kinship usage. Language, 1956, 32, 158-194.
- Makkai, A. & Lockwood, D. G. (Eds.) Readings in stratificational linguistics. University, Alabama: University of Alabama Press, 1973.
- Mancuso, J. C. Bringing personality theory back to home. Personality and Social Psychology Bulletin, 1976, 2, 225-229.
- McEvedy, C. The Penguin atlas of ancient history. Baltimore: Penguin Books 1967.

- McGuire, W. J. The yin and yang of progress in social psychology: seven koans. Journal of Personality and Social Psychology, 1973, 26, 446-456.
- Mead, G. H. Mind, self, and society (Morris, C. W., Ed.). Chicago: The University of Chicago Press, 1934.
- Mehan, H. & Wood, H. The reality of ethnomethodology. N.Y.: John Wiley & Sons, 1975.
- Murphy, G. Personality: A biosocial approach. N.Y.: Basic Books, 1966
- Naroll, R. & Cohen, R. (Eds.) A handbook of method in cultural anthropology. Garden City, N.Y.: The Natural History Press, 1970
- Neisser, U. Cognition and reality: Principles and implications of cognitive psychology. San Francisco: W. H. Freeman & Co., 1976.
- Piaget, J. Genetic epistemology (Duckworth, E., Trans.). N.Y.: Columbia University Press, 1970. (a)
- Piaget, J. Structuralism (Maschler, C., Ed. and trans.). N.Y.: Basic Books, 1970. (b)
- Psathas, G. Phenomenological sociology. N.Y.: John Wiley & Sons, 1973.
- Romney, A. K. & D'Andrade, R. G. (Eds.). Transcultural studies in cognition. A special publication of American Anthropologist, 1964, 66, part 2.
- Rychlak, J. F. Personality theory: Its nature, past, present and--future? Personality and Social Psychology Bulletin, 1976, 2, 209-224.
- Schlenker, B. R. Social psychology and science. Journal of Personality and Social Psychology, 1974, 29, 1-16.
- Secord, P. F. Transhistorical and transcultural theory. Personality and Social Psychology Bulletin, 1976, 2, 418-420.
- Sherif, M. & Sherif, C. W. Social psychology. N.Y.: Harper and Row, 1969
- Spinoza, B. The ethics. In Elwes, R. H. M. (Ed. and trans.), The chief works of Benedict de Spinoza. N. Y.: Dover Publishing Co., 1951.



Spradley, J. P. (Ed.). Culture and cognition: Rules, maps, and plans. San Francisco: Chandler Publishing Co., 1972.

Spradley, J. P. & McCurdy, D. W. The cultural experience: Ethnography in complex society. Chicago: Science Research Associates, 1972.

Sturtevant, W. C. Studies in ethnosience. In Romney, A. K. & D'Andrade, R. G. (Eds.), Transcultural studies in cognition. A special publication of American Anthropologist, 1964, 66, part 2

Van Kaam, A. L. Existential foundations of psychology. Pittsburgh: Duquesne University Press, 1966.

## APPENDIX

As a great deal of this thesis draws on areas that may not be familiar to social psychologists, I would like to append here a brief list of readings. While hardly exhaustive on any of the topics, the books and articles listed will provide, I believe, excellent summarizations of and introductions to these esoteric fields.

### Structuralism

Structuralism is a fairly recent European philosophical basis for research into human experience. The most thorough explication is Jean Piaget's Structuralism (1970), and further illumination can be found in his Genetic Epistemology (1970). The other name most closely associated with structuralism is that of Claude Levi-Strauss. His views are slightly different from Piaget's (as fits his different area of interest) and are best summarized in Structural Anthropology (1963). Selections by these and other structuralists can be found in Lane (1970), and comparisons between Piaget and Levi-Strauss in Gardner's The Quest for Mind (1973). Chomsky and most modern linguists and linguistic anthropologists are also usually considered structuralists,

and I would argue that a number of psychological viewpoints are unwittingly structuralist, such as Neisser's constructionism (1976) and the Sherifs' interactionism (1969).

### Componential Analysis

The roots of componential analysis go back to Chomsky (see 1965), but are more clearly seen in Katz's concept of semantic tags. He thoroughly develops his ideas in Semantic Theory (1972). Actual development as an anthropological technique first occurred independently in Goodenough (1956) and Lounsbury (1956). An excellent overview of the place of componential analysis in the larger area of ethnography can be found in Goodenough's Description and Comparison in Cultural Anthropology (1970). A nice collection of early uses of the technique is Hammel's special edition of American Anthropologist (1965). Finally, a lonely article by Baron (1973) suggests reinterpreting Piaget and Kohlberg in componential terms.

### Ethnoscience

In 1964, American Anthropologist put out a special edition called Transcultural Studies in Cognition, edited by Romney and D'Andrade. It was essentially a "coming-out party" for ethnoscience, including the perhaps defining article by Sturtevant (1964). James Spradley offers a book of readings (1972) and, with McCurdy (1972), a very

readable examination of the use of ethnoscience in our own culture. Finally, a contrast and comparison is included in Psathas' Phenomenological Sociology (1973).

### Stratificational Linguistics

Stratificational linguistics made its appearance when Sidney Lamb sought to reconcile "traditional" modern linguistics (e.g. Chomsky) with some thoughts of Louis Hjelmslev (1961). First, he saw that transformations could be reduced to structure in such a way that we could represent all of language in terms of relations. Second, he saw that Chomsky's three layer system, with the emphasis of the centrality of syntax, would have to give way to a multi-layer system operating in both directions. As this school has developed rapidly, I suggest that the reader look at Makkai and Lockwood's book of readings (1973) for theory and examples, and at Lockwood's Introduction to Stratificational Linguistics (1972) for an explication of the notation, as well as Lamb's original works (1964, 1965, 1966a, 1966b). For a view of the breadth of this approach, see Ikegami's "A Stratificational Analysis of Hand Gestures in Indian Classical Dancing" (1971).

Componential analysis, ethnoscience, and stratificational linguistics find a nearly complete resolution in the works of Geoffrey Leech on semantics (1969, 1970, 1974, and Leech and Pepicello, 1972).

Apparently working independently of the stratificationalists, he acknowledges that Ikegami's The Semological Structure of English Verbs of Motion (1969) is compatible with his own system. I recommend Leech's Semantics (1974) to anyone.

#### Qualitative Methods

Anthropologists, apparently an eminently practical group, have been using qualitative methods since they first arrived, without much fuss as to their theoretical import or epistemological validity. Although one may start anywhere, I suggest Naroll and Cohen's Handbook of Method in Cultural Anthropology (1970).

Sociologists are, apparently, rarely practical, but seem to have excellent philosophical backgrounds with which to justify their techniques. Three schools have things to say:

1. Symbolic Interactionism. Based essentially on G. H. Mead (1934), Blumer is their best spokesman--see his Symbolic Interactionism: Perspective and Method (1969). Also, see Filstead's Qualitative Methodology, a set of essentially Meadian articles.

2. Dramaturgy. Although some suggest that this is a theory, I suggest it is a method based loosely on Burke (1945 and 1950), and outstandingly used by Goffman (1959, 1961, and 1969).

3. Ethnomethodology. This derives from Garfinkle's

fascinating work on "ordinary living" (1962 and 1967), and is excellently expanded upon in Mehan and Wood's The Reality of Ethnomethodology (1975).

Finally, psychologists have simply tended to ignore qualitative methods as somehow inferior. A fine line between the qualitative and the quantitative has been walked by Piagetian and Freudian "clinical interviewing" techniques, and by the naturalistic observation techniques used by Sherif and others. The outstanding exception to the polite acknowledgement of quantity can be seen in some existentialist research. The best explication of research existentialism is van Kaam's Existential Foundations of Psychology (1966).

VITA <sup>2</sup>

Cornelis George Boeree

Candidate for the Degree of

Master of Science

Thesis: GLASS BEADS: TOWARDS AN ALTERNATIVE APPROACH TO  
THE SCIENCE OF SOCIAL PSYCHOLOGY

Major Field: Psychology

Biographical:

Personal Data: Born in Badhoevedorp, the Netherlands,  
January 15, 1952, the son of Cornelis George  
Boeree and Eberdina van Olffen Boeree; married  
Judith Marion Kovarik, April 8, 1972; daughter,  
Jennifer Marie Boeree, born May 24, 1975.

Education: Graduated from Southside Senior High  
School, Rockville Centre, New York, in June,  
1969; received Bachelor of Arts degree in  
Psychology from Pennsylvania State University in  
March, 1974; completed requirements for the  
Master of Science degree in Psychology at  
Oklahoma State University in July, 1979.

Professional Experience: Graduate research  
assistant, Department of Psychology, Oklahoma  
State University, 1976-77; graduate teaching  
assistant, Department of Psychology, Oklahoma  
State University, 1977-78; administrative  
assistant to the department head, Department of  
Psychology, Oklahoma State University, 1978-79.

Memberships: Southwestern Psychological Association;  
Society for the Study of Symbolic Interactionism;  
Phi Kappa Phi.