



# Pumps for Low-Pressure Ground Sprayers

Ronald T. Noyes  
Extension Agricultural Engineer

H. Willard Downs  
Extension Agricultural Engineer

John B. Solie  
Research Agricultural Engineer

Richard W. Whitney  
Research Agricultural Engineer

The pump is the central component of a low-pressure ground sprayer. It supplies flow against pressure to the nozzles, and agitation to the supply tank. To be effective, the pump must deliver constant flow and pressure and be able to handle the desired chemicals without excessive corrosion or wear. The three most commonly used pumps for low-pressure ground sprayers are centrifugal pumps, roller pumps, and piston pumps. Table 1 provides a summary of the characteristics of these three types of pumps.

## Centrifugal Pumps

Centrifugal pumps (Figure 1), which develop pressure as a result of centrifugal force are frequently used for low-pressure sprayers. They are durable, have simple construction, and can handle wet table powders and abrasive materials. Because of their high output (75 to 150 gpm), the spray solution can be agitated sufficiently, even in large tanks. The initial cost of a centrifugal pump is somewhat higher than that of a roller pump, but its long life and low maintenance make it an economical choice. Centrifugal pumps can develop pressures up to about 50 psi with impeller speeds between 3,000 and 4,500 rpm. Output volume drops off rapidly when the outlet pressure is above 30 to 40 psi (Figure 2).

The high impeller speeds require a step-up drive for PTO operation. The simplest and least expensive is a belt-and sheave assembly. Other step-up mechanisms have planetary gears which are completely enclosed and mounted directly on the PTO shaft. Another method of driving a centrifugal pump is with a close-coupled, high-speed hydraulic motor. Using the tractor hydraulic system to drive the pump keeps the tractor PTO shaft free for other uses and makes pump speed relatively independent of tractor engine speed. Pumps can also be driven by direct-coupled engines at speeds between 3,000 to 5,000 rpm.

Single-stage centrifugal pumps designed to operate at shaft speeds up to 6,000 rpm and generate pressures up to 150 psi are available. Although these pumps supply the higher pressures required for some foliar applications, they require more care in pressure control to prevent damage to

Oklahoma Cooperative Extension Fact Sheets  
are also available on our website at:  
<http://osufacts.okstate.edu>

**Table 1. Characteristics of Common Agricultural Pumps.**

	Roller	Centrifugal	Piston
Materials Handled	Emulsions and non-abrasive materials	Any liquid	Any Liquid
Relative Purchase Price	Low	Medium	High
Durability	Pressure and low decreases with wear	Long life	Long life
Pressure Ranges - (psi)	0-300	0-100	0-1000
Operating Speeds - (rpm)	300-1000	2000-4500	600-1800
Flow Rates (gpm)	5-30	0-150	5-60
Advantages	Low cost Easy to service Operates at PTO speeds Easy to prime	Handles all materials High volume Long life	High pressures Wear resistant Handles all materials Self-priming Can be ground driven
Disadvantages	Short life if material is abrasive Relatively low volume	Low pressure Not self-priming Requires step-up drive or high speed hydraulic motor	High cost May need surge tank

other components when the boom valve is closed rapidly. Multiple-stage centrifugal pumps which provide high pressures at lower speeds are also available, but they are much more expensive than single-stage units.

The inlet of a centrifugal pump should never be restricted. A partially clogged suction strainer, collapsed suction line, or a suction line with insufficient size and capacity will result in a loss of pressure and possible damage to the pump. The suction strainer should have an effective straining area several times larger than the area of the suction line, be no smaller than 20-mesh, and be checked and cleaned frequently.

Figure 3 shows the proper plumbing flow path design for a sprayer system using a centrifugal pump. The centrifugal pump varies significantly from the roller pump plumbing assembly (Figure 4).

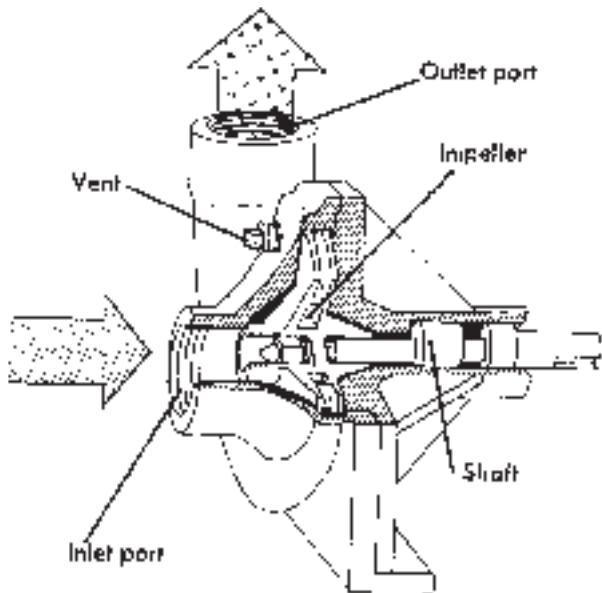

Figure 1. Typical Centrifugal Pump (Cutaway).

1. No relief valve is used.
2. A small plastic vent tube leads back to the tank from the top drain opening in the centrifugal pump housing. This vent line makes the pump easier to prime by bleeding off trapped air when the pump is started. The small stream of liquid that returns to the tank during operation is negligible. Even with this vent tube, the pump should be installed below the supply tank elevation to aid in priming. In place of a vent line, a small petcock also can be installed in the upper drain hole to make priming easier.
3. A line strainer is shown here on the pressure side of the pump. Its primary purpose is to prevent clogging of the spray nozzles. In this location the strainer will not restrict the pump suction line but will clean any particles from the spray solution as it is pumped through the system.
4. Two flow control valves are used—one in the agitation line and one in the line leading to the boom or spray gun. This permits controlling agitation flow independently of nozzle flow.

### To Start and Adjust Sprayer

1. Prime pump with all valves open.
2. Close control valve and agitation line valve; open boom valve.
3. With pump running, open the control valve until pressure gauge indicates desired spraying pressure.
4. Open agitation line valve until sufficient agitation is observed. If spraying pressure drops, re-adjust the control valve to restore desired pressure.
5. Make sure flow is uniform from all nozzles by completing a flow rate check for each nozzle.

### Advantages and Disadvantages of Centrifugal Pumps

The primary advantages of centrifugal pumps are durability, ability to handle wettable powders and other abrasive materials, and high output and absence of a diaphragm type bypass pressure relief valve.

Primary disadvantages are higher cost compared to roller pumps, limited flow at high pressure, and requirement for step-up drive. Centrifugal pumps are still generally the best and most economical choice for most low-pressure sprayer applications.

### Roller Pumps

Roller pumps have relatively low initial cost and are compactly sized, easily maintained, and operate at normal tractor PTO speeds.

These pumps are positive displacement and thus are self-priming. Flow rates from 5 to 30 gpm at pressures up to 200 psi are commonly available.

Roller pumps (Figure 5) are usually constructed with cast iron or corrosion-resistant housings and rotors; nylon, Teflon, or rubber rollers; and Viton, rubber, or leather seals.

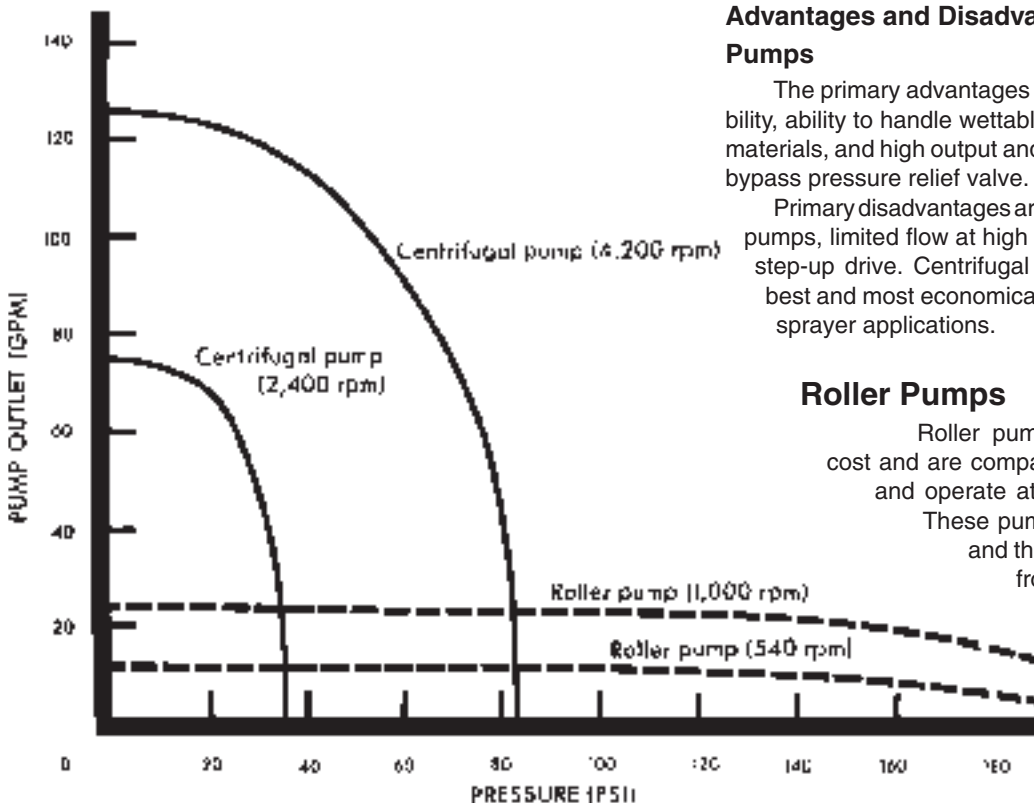

Figure 2. Typical Performance Curve of Centrifugal and Roller Pumps.

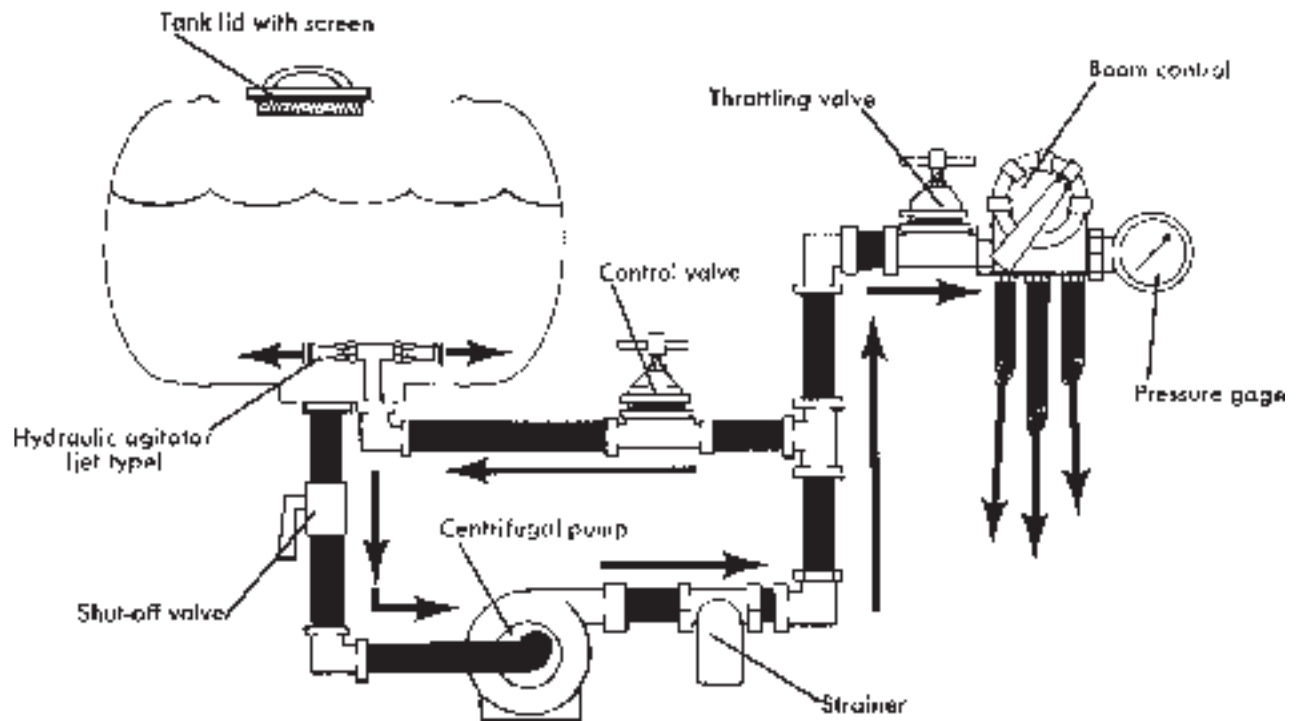

Figure 3. Typical Centrifugal Pump Spraying System.

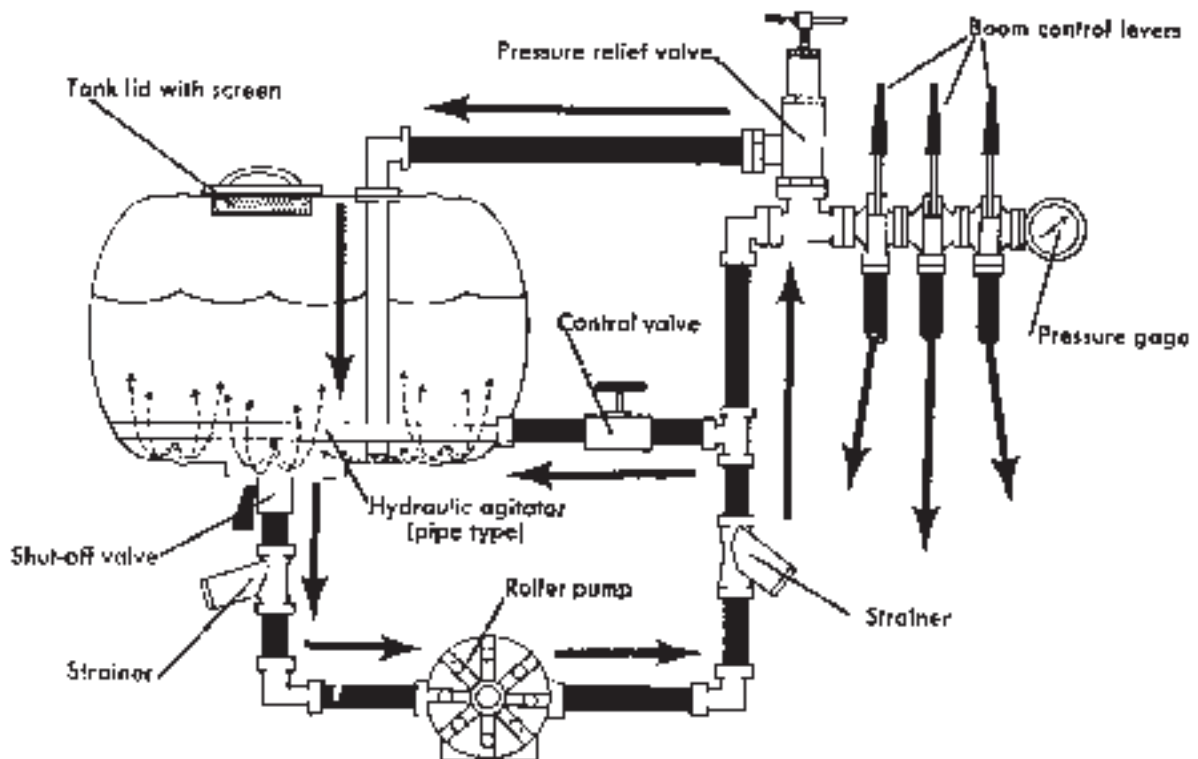
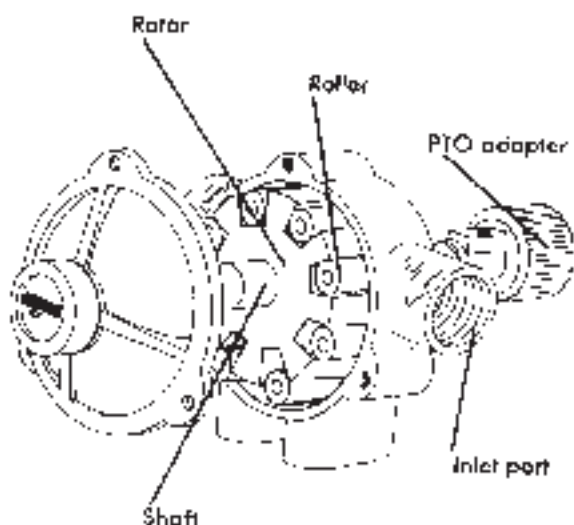

Figure 4. Typical Roller Pump Spraying System.

Nylon or Teflon rollers have proved to be the most resistant to agricultural chemicals and are recommended for multipurpose sprayers. Rubber rollers are preferable when the pump is to be used only for water solutions and wettable powder slurries at pressures under 100 psi. However, rubber rollers should not be used with oil formulations or emulsions because the oil will cause rapid deterioration of the rollers. Polypropylene rollers wear better than either nylon or rubber rollers when applying solutions with poor lubricating qualities. Sand and scale are abrasive to all types of rollers, and care should be taken to keep these materials strained or filtered out of the sprayer plumbing.

Figure 5 illustrates a recommended plumbing design for roller pumps. Notice that the control valve is placed in the agitation line, where it regulates spraying pressure by controlling the by-pass flow.



**Figure 5. Typical Roller Pump (Cutaway).**

### To Adjust this System Properly

1. Close the control valve and open the boom valve (or spray gun).
2. Start the sprayer, make sure flow is uniform from all spray nozzles, and adjust the relief valve until the pressure gauge registers about 10 to 15 psi above the desired spraying pressure.
3. Slowly open the control valve on the agitation line until spraying pressure is reduced to desired value. If the pressure will not come down to the desired value, even with the control valve wide open, replace the agitator nozzle with one that has larger orifices.

Insufficient agitation may result when spraying pressure is correct and there is little or no by-pass flow. A higher pump speed or a larger pump may be needed to provide the necessary flow.

### Advantages and Disadvantages of Roller Pumps

The primary advantages of roller pumps are low initial cost, ease of maintenance, suitability for use with a wide range of chemicals, and ability to operate effectively at tractor PTO speeds.

The major disadvantages of roller pumps are their inability to handle abrasive materials such as wettable powder formulations effectively and limited output volumes. Abrasion can be partially overcome by selecting pump housing made from a high nickel alloy, stainless, or other abrasion resistant materials. Greater outputs will often be required for effective hydraulic agitation. Roller pumps are best suited for small sprayers which are primarily used with highly soluble formulations with little or no abrasive characteristics, and for application where higher pressures are required.

### Piston Pumps

In a piston pump, liquid is drawn in during the intake stroke through an inlet valve. The output stroke forces the liquid out through the outlet valve (Figure 6). Piston pumps develop high pressures which can increase the versatility of a sprayer. Pump capacity is often low, however, and a mechanical agitator may be required in the sprayer's tank. Cost is also much higher per unit of capacity than for the other two pump types. Because of the high pressures, a pressure relief valve must be installed. A surge tank may be necessary to protect gauges, valves and other accessories from pulsating flow.

A common use of piston pumps for agricultural chemical application is on sprayers which use a ground drive to change flow rate proportional to ground speed so that application rates are constant. As increased amounts of liquid are forced through spray nozzles, pressure increases. For most spray nozzles, drift control and droplet size become important as the pressure reaches 40 psi or more. When considering a system which uses a piston pump as a means of controlling flow rate proportional to ground speed, care should be taken to ensure that pressure range limitations of the nozzles are not exceeded. In this application, it is necessary to use mechanical agitation in the supply tank since all the pump's output is directed to the nozzles.

Figure 7 shows the connection diagram for a piston pump. It is similar to that for a roller pump except that a surge tank has been added at the pump outlet.

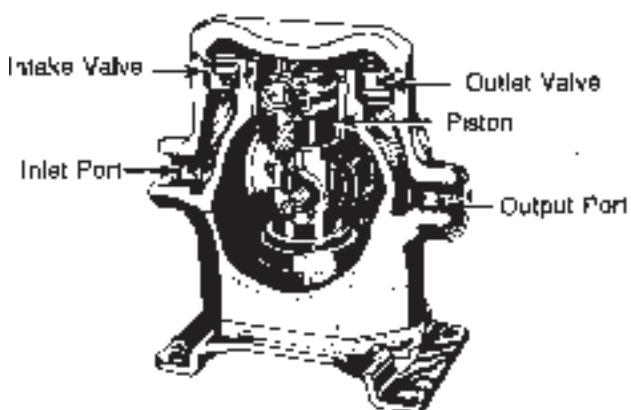

**Figure 6. Typical Piston Pump (Cutaway).**

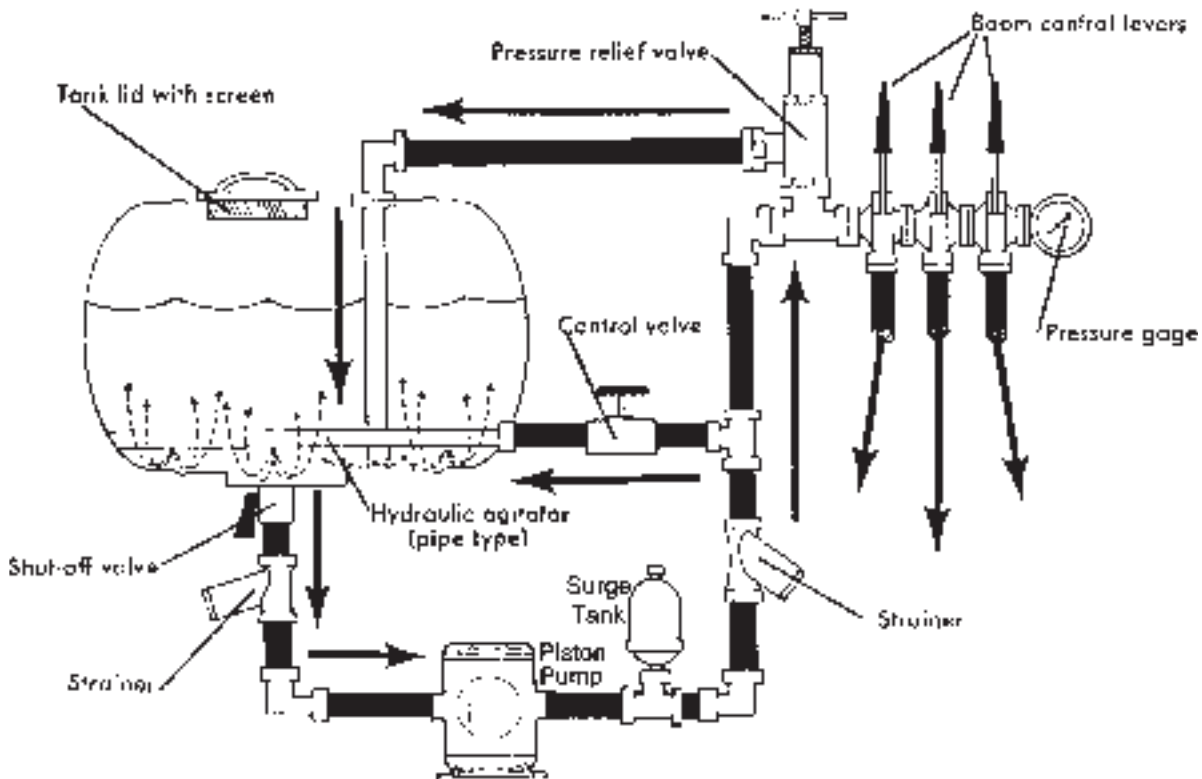

Figure 7. Typical Piston Pump Spraying System.

### To Adjust for Spraying

1. Open the control valve and close the boom valve.
2. Adjust relief valve to open at a pressure 10 to 15 psi above spraying pressure.
3. Open boom valve and make sure flow is uniform from all nozzles.
4. Adjust control valve until gauge reads desired spraying pressure.

### Advantages and Disadvantages of Piston Pumps

The primary advantages of piston pumps are ability to operate over a wide pressure range, excellent durability, and metering capability in a ground-driven mode.

The primary disadvantages of piston pumps are much higher cost per unit of capacity compared to roller and centrifugal pumps, higher maintenance costs, and limited flow rates.

### Pump Capacity

A major factor in pump selection is pump capacity. The pump should have sufficient capacity to supply all the nozzles, provide hydraulic agitation (if used) and offset future pump wear and overcome friction losses. Total sprayer nozzle capacity is determined by multiplying the gallons per minute (gpm) output of the individual nozzle by the number of nozzles on the boom. For example if using a nozzle with an output of 0.7 gpm and the boom has 20 nozzles, then the total sprayer

nozzle requirement is 14 gpm ( $20 \times 0.7 = 14$ ).

The amount of pump capacity which will be required for hydraulic agitation will depend on the type of agitation used. For a standard submerged pipe agitator, allow about 5 gpm per 100 gallons of tank capacity. A 300 gallon tank would require about 15 gpm of the pump's capacity for agitation. With a volume boosting venture jet agitator, the amount of pump capacity required will be in the range of 2 to 4 gpm per 100 gallons of tank capacity, depending on the agitator nozzle selected.

In order to allow for normal friction losses and pump wear, select a pump which is at least 30 percent larger than the total nozzle plus agitation requirements. For example, if nozzle requirements are 7 gpm and the agitation requirement is 15 gpm, select a pump with a capacity of at least  $(14 + 15) \times 1.30 = 29 \times 1.30 = 37.7$  gpm.

### Hoses

Once a pump has been selected, take care to ensure that hoses of the correct size are used to connect the pump to the sprayer components. This is particularly critical for the suction line. Restrictions in the suction side can seriously affect delivery rate and in some cases may cause mechanical damage to the pump. Make sure the suction hose is noncollapsible. Pressure lines which are too small will cause excessive pressure loss, while oversize pressure lines may allow particles in wettable powder formulations to settle out. Table 2 gives recommended hose sizes for suction and pressure lines for various pump outputs.

**Table 2. Suggested Hose Sizes for Various Pump Outputs.**

Pump Output (GPM)			Hose Sizes	
			Suction	Pressure
			Inches I.D.	
0	to	6	3/4"	1/2"
6	to	12	3/4"	5/8"
12	to	25	1"	3/4"
26	to	50	1 1/4"	1"
50	to	100	1 1/2"	1 1/4"

## Maintenance and Care

Pumps must be properly maintained for extended pump life. After each use the pump and entire plumbing system must be thoroughly cleaned to remove all dirt, grime, and chemical residue. If the sprayer will not be used again for several weeks, it should be prepared for storage. Deterioration during storage can consume more of the useful life of the pump than actual spraying use. If the sprayer has no rubber parts (such as gaskets, diaphragms, hoses, or pump rollers) heavy weight

motor oil can be put into the tank prior to the final flushing to coat metal parts and help prevent corrosion. As the water is pumped from the sprayer, the oil will leave a protective coating on the inside of the tank, pump, and plumbing.

In sprayers with rubber components use automotive antifreeze with a rust inhibitor as a final rinse. This will protect against corrosion as well as freezing in case any water remains in the sprayer.

## For Additional Information

For additional information and fact sheets on other sprayer components, sprayer calibration, and on chemical recommendation for various cropping systems, call or visit an Oklahoma County Extension Office.

### Companion Fact Sheets:

BAE-1203 Reducing Drift from Ground Sprayers

BAE-1215 Selecting Nozzles For Low-Pressure Ground Sprayers

BAE-1216 Calibrating a Low-Pressure Ground Sprayer

BAE-1217 The Low-Pressure Ground Sprayer

# The Oklahoma Cooperative Extension Service

## Bringing the University to You!

The Cooperative Extension Service is the largest, most successful informal educational organization in the world. It is a nationwide system funded and guided by a partnership of federal, state, and local governments that delivers information to help people help themselves through the land-grant university system.

Extension carries out programs in the broad categories of agriculture, natural resources and environment; family and consumer sciences; 4-H and other youth; and community resource development. Extension staff members live and work among the people they serve to help stimulate and educate Americans to plan ahead and cope with their problems.

Some characteristics of the Cooperative Extension system are:

- The federal, state, and local governments cooperatively share in its financial support and program direction.
- It is administered by the land-grant university as designated by the state legislature through an Extension director.
- Extension programs are nonpolitical, objective, and research-based information.
- It provides practical, problem-oriented education for people of all ages. It is designated to take the knowledge of the university to those persons who do not or cannot participate in the formal classroom instruction of the university.
- It utilizes research from university, government, and other sources to help people make their own decisions.
- More than a million volunteers help multiply the impact of the Extension professional staff.
- It dispenses no funds to the public.
- It is not a regulatory agency, but it does inform people of regulations and of their options in meeting them.
- Local programs are developed and carried out in full recognition of national problems and goals.
- The Extension staff educates people through personal contacts, meetings, demonstrations, and the mass media.
- Extension has the built-in flexibility to adjust its programs and subject matter to meet new needs. Activities shift from year to year as citizen groups and Extension workers close to the problems advise changes.

### Acknowledgements:

1. Original Manuscript developed by Joseph F. Gerling, former Extension Agricultural Engineer.
2. Selected illustrations were used from University of Illinois Circular 1192.

Oklahoma State University, in compliance with Title VI and VII of the Civil Rights Act of 1964, Executive Order 11246 as amended, Title IX of the Education Amendments of 1972, Americans with Disabilities Act of 1990, and other federal laws and regulations, does not discriminate on the basis of race, color, national origin, gender, age, religion, disability, or status as a veteran in any of its policies, practices, or procedures. This includes but is not limited to admissions, employment, financial aid, and educational services.

Issued in furtherance of Cooperative Extension work, acts of May 8 and June 30, 1914, in cooperation with the U.S. Department of Agriculture, Robert E. Whitson, Director of Cooperative Extension Service, Oklahoma State University, Stillwater, Oklahoma. This publication is printed and issued by Oklahoma State University as authorized by the Vice President, Dean, and Director of the Division of Agricultural Sciences and Natural Resources and has been prepared and distributed at a cost of 42 cents per copy. 0703