

A SYSTEMATIC THEORY FOR CURRICULUM  
DEVELOPMENT AND INSTRUCTION  
IN AN ELEMENTARY SCHOOL

By

RAYMOND D. EDMAN

Bachelor of Science  
Valparaiso University  
Valparaiso, Indiana  
1951

Master of Education  
University of Montana  
Missoula, Montana  
1959

Submitted to the Faculty of the Graduate College  
of the Oklahoma State University  
in partial fulfillment of the requirements  
for the Degree of  
DOCTOR OF EDUCATION  
May, 1972

© 1973

RAYMOND D. EDMAN

ALL RIGHTS RESERVED

AUG 10 1973

A SYSTEMATIC THEORY FOR CURRICULUM  
DEVELOPMENT AND INSTRUCTION  
IN AN ELEMENTARY SCHOOL

Thesis Approved:

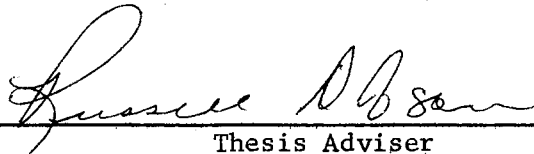
  
\_\_\_\_\_

Thesis Adviser

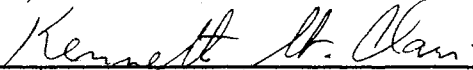
  
\_\_\_\_\_

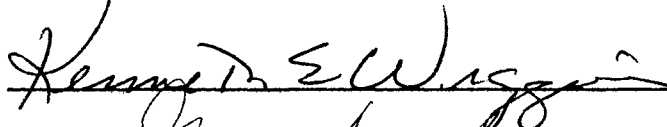
  
\_\_\_\_\_

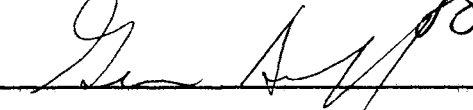
  
\_\_\_\_\_

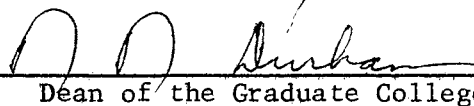
  
\_\_\_\_\_

Dean of the Graduate College

## PREFACE

This dissertation proposes a theory, with an accompanied model, for curriculum development and instruction in an elementary school. A rationale is developed for the theory and the major components of curriculum are identified as the nature of man, the nature of society, the nature of knowledge, the nature of the learner, and the nature of learning. A major theoretical consideration is that all of the above natures together with the nature of values provide the individuals within the elementary school with a force that provides direction for their actions. These actions subsequently determine curricular and instructional patterns.

Systems theory provides the framework for the proposed theory as the elementary school is viewed as a system. The theory is put into practice by providing an example of the system being put into operation.

I wish to express my gratitude to Dr. Russell Dobson for his thought-provoking questioning and assistance; to Dr. Kenneth St. Clair for his many helpful suggestions; and to Dr. Kenneth Wiggins and Dr. Gene Acuff for their interest and service as committee members.

I would like to thank Mrs. Mildred Lee for her typing and assistance with format.

To my wife Lucy, I wish to express my sincere appreciation for her unrelenting support and encouragement in the preparation of this dissertation. I wish to thank my daughter Brenda, and son Mark, for their concern and patience during the time this dissertation was written.

## TABLE OF CONTENTS

Chapter	Page
I. INTRODUCTION . . . . .	1
Rationale . . . . .	2
The Problem . . . . .	7
Definition of Terms . . . . .	7
II. THEORY AND MODELS . . . . .	9
Theory . . . . .	9
Models . . . . .	12
III. DIMENSIONS OF THE THEORY . . . . .	15
Major Assumptions . . . . .	15
Parameters . . . . .	17
Philosophical Considerations . . . . .	18
IV. THE ELEMENTARY SCHOOL AS A SYSTEM . . . . .	54
Definition of Terms . . . . .	55
Systems Concept and Techniques . . . . .	56
V. A CURRICULUM DEVELOPMENT THEORY . . . . .	67
Development of the Mission . . . . .	68
The Mission Profile . . . . .	69
Function Analysis . . . . .	71
VI. THEORY INTO PRACTICE . . . . .	89
BIBLIOGRAPHY . . . . .	107

## LIST OF FIGURES

Figure	Page
1. A System . . . . .	57
2. Mission Profile . . . . .	59
3. Vertical Stepdown . . . . .	60
4. Parallel and Alternate Paths . . . . .	61
5. Task Analysis . . . . .	62
6. System Interrelationships . . . . .	64
7. System Synthesis . . . . .	64
8. Mission Profile . . . . .	70
9. Need Assessment . . . . .	72
10. Need Selection . . . . .	74
11. Solution Sources . . . . .	75
12. Program Determination . . . . .	77
13. Staff Needs Determination . . . . .	79
14. Staffing Processes . . . . .	80
15. Implementation . . . . .	81
16. Evaluation Processes . . . . .	84
17. A Theoretical System . . . . .	85
18. Need Determination . . . . .	91
19. Task Analysis . . . . .	92
20. Methods-Means Analysis . . . . .	93
21. Solution Strategy Determination . . . . .	95

Figure	Page
22. Knowledge Determination . . . . .	97
23. Instructional Strategy Selection . . . . .	98
24. Staff Selection . . . . .	100
25. Implementation Procedure . . . . .	101
26. Methods Analysis . . . . .	103

## CHAPTER I

### INTRODUCTION

An educational theory which ultimately affects decisions about the most appropriate practices employed to accomplish the societal, institutional, and individual goals of formal education should include both philosophical propositions and existing scientific evidence. Questions concerning the adequacy of the theory and its validation should occur when the theory is applied to real life situations.

It is proposed in this paper to develop a systematic curriculum theory. This theory will have a heuristic role to perform. A conceptual model will be derived from the theory that could be used by those persons involved in curriculum development in an elementary school.

Curriculum theorizing is a challenging undertaking of an extremely complex problem. James B. Macdonald (1967, p. 169) alludes to this by stating,

Curriculum theorizing calls for immersion in the concrete data of curriculum experiences; awareness of general ideas and developments in such areas as psychology, sociology, anthropology, biology, philosophy, and theology; knowledge of historical and contemporary developments and theories in curriculum; and a willingness and ability to utilize both aesthetic and technical rationality in the process of theorizing.

It is hoped that in the development of the theory and designing of the model that the gap may be closed to some degree between theory and practice.



## Rationale

The curriculum, when viewed from a historical perspective, has been under study by such persons as Comenius, Pestalozzi, Spencer, Herbart, Rousseau, Froebel, Mann, and Dewey. In the 1890's the curriculum of the schools in the United States attracted the attention of both those inside and outside the profession. At this time many criticisms were voiced against formalism, narrowness, and hard discipline in the school's curriculum. Curriculum as a field of study began emerging after 1915. The first book published on the subject of curriculum was by Franklin Bobbitt (1918). City school systems such as Los Angeles, Denver, St. Louis, and Winnetka set about to investigate the curriculum and make revisions that seemed to be necessary. A second major written work, Curriculum Construction by W. W. Charters (1923), further concentrated thought on curriculum as a field of educational inquiry. Harold Rugg (1926) and others collaborated in writing a large section of the Twenty-sixth Yearbook of the National Society for the Study of Education that concentrated on curriculum construction and revision. In the 1930's a major impetus was provided to the curriculum movement by the Eight Year Study of the Progressive Education Association. Caswell (1966) noted two developments which were of particular significance to curriculum study. The first was the organization of the Department of Curriculum and Teaching at Columbia University in 1937, and the second was the establishment of the Association for Supervision and Curriculum Development at about the same time. The latter organization has contributed a large portion of the professional writing on curriculum in the past thirty years. Herrick and Tyler (1947) published a set of papers from a University of Chicago conference that were aimed at

addressing the problem of a more adequate theory of curriculum.

Eisner (1967, p. 132) comments that this publication is considered "a basic document in the field of curriculum and one of its most sophisticated statements."

There has been a multitude of changes in the curriculum since 1947. Mathematics has been subject to extensive curricular revision in the elementary and secondary schools. Secondary science has been under reformation with programs in physics, chemistry, biology, and earth science. Elementary science has followed with several national study groups and projects. The social sciences and humanities have followed suit. English, foreign language, and health education have also been examined, revised, and reformed. While most of these changes could be attributed, either directly or indirectly, to national concern after Sputnik in 1957 several were underway prior to its launching. These curricular changes that took place in the fifties and sixties are now being severely questioned in regard to both type of change and direction of change. Perhaps the most piercing question concerns the absence of a theoretical base from which decisions are made that result in these changes.

The main emphasis of curriculum development in the past few years has centered upon the disciplines themselves. According to Goodlad (1966) the outcomes of the recent curricular reform movement have contributed positively to education in several ways. The involvement of scholars, the new psychological perspectives on learning, the in-service education of teachers, the use of multi-media and the infusion of new funds and personnel have all contributed to a better educational program. At the same time he sees several factors as definite

liabilities inherent in the changes that have been brought about. Focusing on separate disciplines which were already in the curriculum, planning from the top down, rigidity of instructional packages, a broken front separate piece approach to curriculum planning, the difficulty of making value decisions as to what subject is to be taught for how much time, and the failure to specify goals and objectives are characteristic of many of the programs and projects which are of doubtful value.

Many other scholars are now pointing out discrepancies and deficiencies of the recent reform movement. They decry the lack of curriculum development theory and advocate thinking and action that would provide a more solid base from which curriculum workers could operate. Early in the reform period Taba (1962) claimed that curriculum development since World War II suffered from arrested progressivism with the result being a kind of vacuum. She goes on to say,

. . . a theory of curriculum development is needed. Such a theory should not only define the problems with which curriculum development must deal, but also elaborate the system of concepts which must be used to assess the relevance of these data to education. (p. 6)

The Review of Educational Research provides two statements, one in June of 1960 and the other in June of 1966, that also seem to point out this need. Goodlad writes the first to say,

Curriculum theorizing to date is best described as abstract speculation, curriculum research as dust bowl empiricism; and curriculum practice as a rule of thumb guesswork (often a wet thumb at that, held aloft to test the direction of the prevailing breeze). (p. 195)

Shaw (1966) writes the second statement,

"Theory has not played a decisive role in influencing curriculum change. The reasons have not been difficult to find. Curriculum specialists found clues in other areas of

research, but a comprehensive theoretical structure was conspicuously lacking.

Fragmentation of the curriculum in recent years has been the target of criticism from several sources. The thinking seems to be that this fragmenting will lead to a more rigid curriculum than ever before, and that too much artificial separation will not allow for flexibility in learning. Fragmentation frequently leads to addition of new courses without deletion of old. Klohr (1969), Sand and Myers (1966), Foshay (1968), and Tanner (1966) all pursue this criticism in their writings.

If such is the case concerning curriculum reform and curriculum theory then in what direction and ways might a curriculum theorizer proceed to contribute significantly to the complex problem of curriculum development? Many thoughts and recommendations in the current literature seem to be trying to point the way.

Tanner (1966) comments that the curricular reform movements have stimulated attempts at theory building. He and Mann (1968) both point out that curriculum theory is still in its infant stages and that there has not as yet been developed a discipline of curriculum theory.

Klohr (1967) takes a firm stand in opposing the introduction of so-called innovations which are ready made into the curriculum without first examining them with critical questions from a sound theory base. He and others are taking positions that we must look at curriculum development in its larger context. Cremin (1965) and Broudy (1966) voice their concerns that we must look at curriculum in its entirety and with a unifying theoretical base. Alberty (1967, p. 205) states, "It is time to examine the total curriculum. What is needed now are new ways of looking at the curriculum as a whole, and new frameworks

for developing curricula appropriate for modern living in a democratic society." Sand and Myers (1967, p. 55) concur when they say that the patch-up method of curriculum reform needs to be supplanted by a more rational approach, "one that attempts to consider all of the components and their relationship to each other and to the whole rather than a few components considered in isolation." They continue to say that development of theories in curriculum and instruction undoubtedly constitutes the only long term solution to the problems confronting the field.

Several persons in the field are advancing ideas of a more specific nature that they feel might contribute to solving curriculum development problems. Goodlad (1958, pp. 381-401) specifies the following:

Conceptual systems which identify the major questions to be answered in developing a curriculum must be rigorously formulated. The elements that tie these questions together in a system must be classified; subordinate questions must be identified and classified properly in relation to the major questions; sources of data to be used must be revealed in answering the questions posed by the system; and the relevance of data extracted from these sources must be suggested.

Klohr (1969) refers to what he calls the "design problem." He is basically referring, in the writer's opinion, to theories and models in this instance. His contention is that we have been working in curriculum with ideas, concepts and design models that are twenty or more years old. Klohr feels that we have not designed the conceptual tools to critically analyze the "design problem" that presently confronts curriculum development. He specifically states, "We need more adequate conceptual frameworks . . . for engaging in examination as well as for handling current and future efforts." (p. 93) Sand and Myers (1967) also are specific in this area. They concede that there are few theories or even conceptual models in the field of curriculum or instruction that attempt to find a logical or rational place for all components. They

also state that the most fruitful route to help solve the problems of the next decade,

. . . would appear to be by the careful development of conceptual models built on sound principles that help explain the complex interrelationships of the diverse phenomena under study - to identify rigorously the various components that hold the field of education together. (p. 54)

### The Problem

The central problem of this study was to develop a theory of curriculum instruction development for an elementary school. In order to fulfill this obligation it was necessary to determine the major components of the process of curriculum development and designate the interaction and sequencing of these components in a systematic manner and finally a model was constructed to serve as an analogy to the theory.

### Definition of Terms

The following terms are operationally defined in order to maintain consistency throughout the paper.

Curriculum - is a set of events, either proposed, occurring, or having occurred which has the potential for reconstructing human experience. (Duncan and Frymier)

Curriculum Development - is the structuring and restructuring of the interaction that takes place in the curriculum.

Theory - is a statement of relationships among observed data which is tentatively accepted but not finally demonstrated. (Harriman)

Model - is an analogy. (Chapanis)

School - is a social institution invented and developed by man for the purpose of perpetuating and enhancing that culture in which he finds himself.

Learning - is the process of making sense out of things.

Component - is a major identifiable part of a system.

Knowledge - is a model we construct which gives meaning and structure to the regularities we experience. (Bruner)

System - is a series of interrelated parts interacting to accomplish a goal.

Mission - is the statement of the global goal of a school. It states what is to be accomplished, when, and by whom.

Function - is the statement of major jobs that are necessary to perform in order to accomplish the mission.

Task - is the most discrete performance undertaken to complete a function.

Evaluation - is the assessment of progress in the achieving of a previously stated goal.

Teaching - is an interactive process which takes place between teacher and students which occurs during certain definable activities. (Amidon)

## CHAPTER II

### THEORY AND MODELS

The purpose of this section is to investigate the following aspects of theory: definition, characteristics, criteria for construction, and function. An investigation of the same aspects of models is made, followed by a study of the interrelationships between theories and models. Along with the rationale this theory and model discussion should provide the underlying structure for the construction of the theory and model for curriculum development.

#### Theory

Harriman (1947, p. 330) defines theory as "a statement of relationships among observed data which is tentatively accepted but not finally demonstrated." Griffiths (1958) states that a theory is a set of assumptions from which a set of empirical laws can be derived by a strictly hypothetico-deductive means. Homans (1950) and Eisner (1967) place emphasis on theory as a descriptive tool. Theory describes the results of observations of either a large or small domain.

Gordon, et al. (1968) categorize their definitions into mathematical theory, philosophical and humanistic theory, and scientific theory. They conceive mathematical theory to be a set of interrelated propositions that have been derived from a set of axioms. Philosophical and humanistic theory comprises a set of consistent and logical



formulations about man's place in the world while scientific theory is defined as a set of propositions inductively derived from empirical findings.

From the above discourse it is quite evident that there is more than a single accepted definition of the term theory. Eisner (1967, pp. 133-134) describes this situation in the following manner:

Theory as it is used in educational discourse has . . . no simple or precise meaning. And even where precisions regarding the meaning of theory exists, a number of definitions are available. In short there is no universally agreed upon definition of theory.

Scott (1968) similarly comments that it is no secret that all theorists do not define theory the same way, but a person's definition is important when it becomes a guide to his action.

It is difficult to differentiate between theory characteristics, function, and evaluative criteria because they are so interrelated. The characteristics usually given to theory are: comprehensiveness, consistency, predictability, operationism, descriptiveness, explanation, and objectivity. Sidman (1960) adds relevance, fruitfulness, and simplicity to this list while Griffiths (1959) adds serving as a guide to action and collecting new facts and knowledge.

The explanatory function of theory is well described by Nagel (1961) when he says that most sophisticated use is to designate a system of general statements capable of explaining empirical regularities. Mann (1968, p. 372) does likewise as he comments,

Theory is explanatory and explanation leads, in many cases, to control or at least to prediction. In the long run theory coupled with value commitment leads to a position about practice.

Mouly (1963) and Eisner (1967) stress the predictive function of theory. Ryans (1965, p. 38) differs with the idea of description and

operation functions of theory. He claims the chief function of a theory is "to provide a framework for observation and analysis." Ward (1961) views the integration of conceptions, views, and understandings as a prime function. He says that from integrated theory practice can be deduced.

The later theorists seem to be stressing the analytical, inquiring, and system building functions of theory. Gordon, et al. (1968)<sup>1</sup> in an Association for Supervision and Curriculum Development publication have evolved a set of criteria for evaluating theories of instruction. It is a comprehensive list and may be applicable, at least in part, to theories in other areas. The criteria are as follows:

1. A statement of an instructional theory should include a set of postulates and definition of terms involved in those postulates.
2. The statement of an instructional theory or subtheory should make explicit the boundaries of its concern and the limitations under which it is proposed.
3. A theoretical construction must have internal consistency - a logical set of interrelationships.
4. An instructional theory should be congruent with empirical data.
5. An instructional theory should be capable of generating hypotheses.
6. An instructional theory must contain generalizations which go beyond the data.
7. An instructional theory must be verifiable.

8. An instructional theory must be stated in such a way that it is possible to collect data to disprove it.
9. An instructional theory must not only explain past events but also must be capable of predicting future events.
10. At the present time instructional theories may be expected to represent qualitative synthesis.

### Models

Models and model building are topics and terms about which there has been much written in the past few years. The substantive portion of the literature has been in fields outside of education but in approximately the last five years the education profession has shown increased interest and productivity in this field. One of the most persistent problems concerned with models has been with definitions and terminology.

Perhaps the most succinct and frequently referred to definition of a model is given by Chapanis (1961, p. 114). He states, quite simply, "Models are analogies." He amplifies this by commenting that models are "representatives, or likenesses, of certain aspects of complex events, structures, or systems made by using symbols or objects which in some way resemble the thing being modeled." Travers (1963) concurs by stating that a model is an analogy that can be very useful in the understanding of phenomena. Kendall (1968, p. 1) gives an expanded definition by declaring a model to be:

. . . a specification of the interrelationships, of the parts of a system, in verbal or mathematical terms, sufficiently explicit to enable us to study its behavior under a variety of circumstances and in particular to control it and predict its future.

By using the last phrase he is attributing to a model some of the characteristics of a theory. The idea that a model depicts a series of relationships between various factors or variables is further suggested by Hilgard (1956) and Belanger (1964).

Models are useful in theory development. Theories can contribute to model construction and models in turn, by conceptualizing theory, can aid in the expansion of that theory. Achinstein (1964) in expressing this function of a model says that by establishing an analogy between the objects in a theory and objects which may be more familiar a model enables the scientist to achieve a better grasp of some of the basic concepts in the theory. The functional relationship of a model and theory is further clarified by Hutten (1956, p. 34), "The model that underlies a scientific theory is of greatest import, in most instances the model is tacitly assumed, but we must bring it out into the open if we want to understand the theory."

Again Chapanis (1961) lists the functions of models and declares them to be advantageous in the following ways:

1. Models describe and help us understand complex systems or events.
2. Models help us learn complex skills.
3. Models provide the framework within which experiments are done.
4. Models help us to see new relationships.
5. Models help us to predict when experiments are impossible.
6. Models assist in engineering design.
7. Models amuse us. They are fun to design, fun to build, and fun to look at.

He also cautions those persons involved with models and model building that there are inherent dangers in the process. He lists these as:

1. Models invite overgeneralizations.
2. Models entice us into committing a logical fallacy.
3. The constants assumed in the model may be incorrect.
4. Models are often not validated.
5. Model building diverts useful energy into nonproductive activity.

It is the position in this paper that there is a definite distinction between a theory and model even though there is a series of relationships between the two. It is the writer's intent to develop a curriculum theory and propose a model for that theory,

## CHAPTER III

### DIMENSIONS OF THE THEORY

#### Major Assumptions

The theory presented in the pages which follow is based upon several major assumptions. All statements made theoretically are using these assumptions as referents.

1. There are basic philosophical considerations from which a school operates. The main sources of these considerations are:
  - (a) Idealism, which tends toward providing a universal scope.
  - (b) Realism, which provides a sort of dispassionate objectivity.
  - (c) Pragmatism, which tends to provide a social intelligence with a practical base.
  - (d) Analysis, which provides for logical precision.
  - (e) Existentialism, which provides for human concern.
2. There have been major goals defined for the educational process in the United States. The most persistent goals center on:
  - (a) The ideal of intellectual discipline.
  - (b) Economic independence and vocational opportunity.
  - (c) Citizenship and civic responsibility.
  - (d) Social development and human relationships.

- (e) Morals and ethical character.
  - (f) Self-realization including health and psychological needs.
3. There are several commonly accepted learning theories that provide the basis for instruction. Mainly these theories have been the following:
- (a) Faculty psychology.
  - (b) Behaviorist or associationist theory.
  - (c) Gestalt theory.
  - (d) Field theory.
  - (e) Phenomenological theory.
4. There are accepted definitions of instructional strategies. Some of these are:
- (a) Individualizing strategies such as programmed learning or tutoring.
  - (b) Inductive strategies such as inquiry techniques.
  - (c) Discursive strategies such as employed in small group instruction.
  - (d) Didactic strategies such as lecturing.
5. There is a social system within which an individual school operates.
6. The school itself has its unique social system.
7. The individual school is the basic unit of organization in which changes are most likely to occur.
8. The curriculum is composed of several specific components. The components most commonly referred to are:
- (a) The nature of man.

- (b) The nature of society.
  - (c) The nature of knowledge.
  - (d) The nature of the learner.
  - (e) The nature of learning.
  - (f) The nature of values.
9. There are interrelationships and a constant process of interaction between these components within an elementary school.
  10. There are assessment procedures that can be used to measure the outcomes of the educational process.
  11. Change is a constant.

#### Parameters

One may take a wholistic view of a world society and its vast variety of organizations, both large and small, that have as their purpose the educating of the young. The first degree of limitation for this study is focus upon the United States with its complex organization of elementary, secondary, and higher education systems. Further limitation within elementary education will be to investigate an elementary school with its population of children ranging approximately between the ages of five to twelve.

There is a community surrounding this school whose boundaries cannot be absolutely defined. Definitions of these boundaries are usually determined by the socio-politico-geographical area in which students attending a particular school live. Further boundary definition is accomplished by including the following factors: (1) the physical plant of the school; (2) the administrative, teaching and supplementary staff of the school; (3) the parents of the students;



and (4) the students themselves.

With a full realization of the haziness and constant fluctuation of these boundaries this study will be confined to a single elementary school. The study will be further limited to the curriculum-instruction developmental process within a given elementary school. This process will be viewed from a system perspective with full awareness of the suprasystem and subsystem relationships.

### Philosophical Considerations

The curriculum is based upon certain philosophical considerations. One of the major assumptions (pp. 16-17) states that these considerations are the following:

- (a) The nature of man.
- (b) The nature of society.
- (c) The nature of knowledge.
- (d) The nature of the learner.
- (e) The nature of learning.
- (f) The nature of values.

The sections which follow are devoted to these natures. Although each section is a synthesis of the contributions of many writers and scholars in the field, it is by no means exhaustive. An attempt is made to present these statements with as little bias as is possible. The statements are, therefore, what has been or is being said and not necessarily what should be said.

It is contended that whenever the curriculum is in process of development those persons within the system are being affected either consciously or unconsciously by these philosophical considerations.

These affectations influence the behaviors exhibited in the interactions within the system.

It is also contended that the nature of values is the all-pervading force which plays upon each of the preceding natures. For example, an individual's position as to how a child learns is strongly dependent upon his own value system.

### The Nature of Man

For centuries man has contemplated about his nature. Although it seems that knowledge about man has accumulated throughout these years, especially in recent times, most scholars believe that truly knowing man is a highly complex unsolved problem. Phenix (1958, p. 461) points out, "Man is himself so deeply involved in being human that he cannot clearly and surely know what he is."

Modern science, especially physics and biochemistry, has given us a clearer understanding of the chemical and psychological makeup of man. Quantum theory has shed new light on energy and matter relationships which in turn has provided insight into genetic composition, growth characteristics, and biological functioning process.

Nevertheless what a person knows about man is usually reflected in his beliefs about man and subsequently surfaces in his actions that involve other persons. It is not the writer's intention to stand upon a definition of the nature of man but to provide what seems to be the basic views of human nature. In the synthesis of these views a categorization is used which best seems to depict the convergence of these highly diverse views. The three aspects to be considered are: whether man is good, evil, or neutral; whether he is active or passive; and

whether he is rational or irrational.

When an individual views man as basically evil he can draw upon much support from science and religion as well as history. Darwinian evolutionary theory provides the survival of the fittest concept which has been interpreted to see man as basically cruel and aggressive. Freudian psychology has also provided the view of man as evil with sublimated desires, hostility and driving aggressiveness. Freud (1955, p. 85) says,

. . . men are not gentle, friendly creatures wishing for love, who simply defend themselves if they are attacked, but . . . a powerful measure of desire for aggression has to be reckoned as a part of their instinctual endowment.

History is replete with accounts of man's cruelty in such instances as the Hun and Mongol invasions and Hitler's ovens.

Perhaps the strongest persistent view of man as being evil comes from Hebraic-Christian fundamentalists. Quoting such passages from the Bible as Genesis (8:21), "The imagination of man's heart is evil from his youth," supporters of this view of man believe that man is sinful and he must be brought back from the Fall. From this perspective, to be human is to be evil. This does not necessarily mean that man cannot become good but that he can only do so through external influences such as a Supreme Being.

The position of man being inherently good can also be supported with evidence from several sources. The religious foundations for this view come from several biblical sources which indicate that men are made in God's image and there is a bit of God's goodness in everyone. Jesus' statement that, "The Kingdom of Heaven is within you", is a religious indication of the goodness in man.

Rousseau's Emile is a classic example of a statement of the position that if a person is allowed to unfold naturally, his inherent goodness will eventually become apparent.

Recent research and writings in the field of human development are providing support to the view of man as being basically good. Coleman (1960, p. 28) comments upon the growing number of people and evidence which is giving credence to the positive view of man's nature. He describes this movement as saying,

Man is basically good if permitted to develop his natural propensities. Only when his nature is distorted by pathological conditions, rejecting parents, constant failure and rebuff or a repressive culture does he become aggressive and cruel.

Maslow (1954, 1962), Allport (1954), Kelley (1952), and Combs (1962) all bring statements and evidence to promote this concept of man's goodness.

The third position of looking at this aspect of the nature of man claims a neutral ground. Those persons who adopt this view see man as being neither good nor bad but being neutral. According to Blakney (1960) Kant claimed that man is neither good nor bad, he only becomes a moral being when his reason has developed ideas of duty and law. Maslow (1962, p. 34) expressed himself this way, "This inner nature, as much as we know of it so far, is definitely not evil but it is either what we adults call good or else it is neutral." Investigation of the living culture of Arapesh of New Guinea and the Blackfoot Indians by Mead (1939) and Maslow (1954) respectively, offer evidence that points toward this neutral nature of man.

The second category of man's views of man deals with the question of whether man is an active creature or whether he is passive. The

views held on this category would seem to profoundly influence curriculum selection and teaching strategies.

The view that man is passive correlates highly with deterministic philosophy. Calvinism with its tenets of predestination is an example of this philosophy. Until the splitting of the atom and development of quantum theory determinism held sway as the dominant field of thought in the physical sciences. An example of change here is evidenced by the shift away from Bohr's classic model of the atom to the electron cloud model. Scientists are saying that their prediction capability is very high but there is still a place for indeterminacy.

Behavioral psychologists view man as a passive creature. Bigge (1964) characterizes C. H. Hull, B. F. Skinner and R. W. Spence as reinforcement - conditioning psychologists who have supported this view.

To view man as active, purposive, and emerging opens up an entirely different perspective of his basic nature. Kelley and Rasey (1952) are proponents of this view as they argue that life is a process, movement, and flux and that man is in the process of becoming. They also feel that in experiencing man reacts, evaluates, and projects. The evaluation and projection aspects place man beyond the passive state. Maslow (1962, p. 234) states, "We can no longer think of a person as fully determined. . . . The person insofar as he is a real person, is his determinant." Coleman (1960, p. 11) in summing up this position taken by several eminent psychologists, makes the following point;

Much of human behavior, certainly, is determined by conditioning; our opinions, our values, and ways of behaving all reflect the experiences we have had, and thus the culture in

which we live. But this does not tell the whole story. Man is also creative and purposeful.

The argument over whether man is rational or irrational by nature has continued for centuries. Most advocates of dictatorship forms of government have pointed to man's irrational aspects as justification for a certain elite few to maintain control over the masses. Freudian psychology points out that man cannot act rationally because of his internal subconscious drives.

Perhaps the best evidence of man's rationality comes as we view his accomplishments since the Enlightenment through the Industrial Revolution to the highly technological society in which we exist today. Man's continuing quest to make sense and order out of his environment has therefore provided creditability to his rationality.

Chapman (1970a) makes a strong contention that man's basic nature is both rational and irrational. He says,

. . . in recent times the over-emphasis of man's rationality has had disturbing effects upon his relationship toward others. We seem to have forgotten entirely that man is also irrational by nature.

This view, then, would focus more upon a balancing process as man interacts with his environment and his fellows.

### The Nature of Society

Human beings get together to accomplish things that they cannot accomplish individually. Society's fundamental structure has come about as a result of man's struggle to satisfy his basic physical needs such as food, clothing, and shelter. As these needs are satisfied he reaches for the satisfaction of higher needs that are concerned with self-esteem and self-actualization. The creation of groups ranging

from two to millions has been brought into existence. This existence has brought about institutions that can be used by man for any purpose which he may desire and they can operate to satisfy the total range of man's needs.

MacIver (1949a, p. 1) states, "Wherever there is life there is society. It is within us as well as around us." This definition of society is further expanded when he has this to say in another writing (1949b, p. 5):

Social beings, men, express their nature by creating and re-creating an organization which guides and controls their behavior in myriad ways. This organization, society, liberates and limits the activities of men, sets up standards for them to follow and maintain; whatever the imperfections and tyrannies it has exhibited in human history, it is a necessary condition of every fulfillment in life. Society is a system of usages and procedures, of authority and mutual aid, of many groupings and divisions, of controls of human behavior and of liberties. This everchanging complex system we call society. It is the web of social relationships.

J. O. Hertzler (1961) views society as a system. He defines a system as an orderly combination of parts into a whole which is much more than a mere aggregate of its parts. These parts are interconnected and interdependent and they function or operate both mutually and in reciprocity. The real key to a human social system is that it is like no other system because it consists of interacting human beings. Hertzler (1961, p. 5) lists the features of a human social system as the following:

1. Symbolic communication
2. A background of culture relatively meaningful to all or most of its members
3. Complexity and heterogeneity of population functions, collectives, and subsystems
4. Mental and spiritual life of the members

5. Value orientation
6. Goal attainment
7. Ideological agreement and psychic and moral unity
8. Culturally established patterns of action
9. Sociocultural regulation and maintenance
10. Institutional setting and ordering
11. Deliberate boundary maintenance
12. Social reorganization and reconstruction
13. A constructed--not a nature given--mechanism

From this point of view society is a field of action and interaction.

There is a large extent of agreement upon the basic unit of society. Chapman (1970b) points out, "Society is based upon the ability of two people to form a dyadic relationship that involves reciprocity." When you move from more than two people you are forming a primary group. Primary groups have been characterized by Cooley (1956) as having intimate face to face association and cooperation. These primary groups are similar the world over. The most important primary groups as far as the individual is concerned are the family, the play groups, and the neighborhood. According to Cooley (1956, p. 220), "These are . . . accordingly the chief basis of what is universal in human nature and ideals."

Usually social groups that do not have the aforementioned characteristics of primary groups are called secondary groups. Interaction within social groups is aimed toward the satisfaction of human needs. Certain groups then have certain functions or jobs to perform in order to satisfy human needs. Within each of these groups individuals occupy certain positions which have been defined as to their status. Certain



stated or unstated propositions define the conduct of individuals within these groups and are frequently referred to as norms. Society then is composed of a multitude of groups. Although societies vary in clarity and position of these groups there is a tendency to stratify these groups horizontally which usually leads to a hierarchy.

In the interaction between these groups several patterns of process seem to emerge. The most basic of these processes is cooperation. If common goals aimed at satisfaction of human needs seem to be characteristic of groups then cooperation is a necessity. However, two other processes, competition and conflict, also may enter the picture.

Man learns from experience, he creates new things, and he behaves and believes in certain ways. The patterned way of life that man lives as a result of the transmission of experiences, creation, behaving, and believing is called his culture. "A human society does not exist apart from a culture" is the approach that Havighurst and Neugarten (1967, p. 8) take. Hertzler (1961, p. 14) says, "Every human society has a culture; in fact, cultures above all else, explains man's uniqueness." There is an interaction that takes place between an individual and his culture. Particularly in early life an individual is shaped and guided in his development by his culture. This process, known as acculturation, in turn, allows the individual to acquire a given culture. G. H. Mead's (1934) writings on the early socialization of man reflect this point of view. Mead sees the acquisition of language and the child's acting in play and games as the two processes by which culture is acquired in early life. Through these processes a child acquires membership in a society and becomes a product of that society and a bearer of its culture.

As the writer has viewed the nature of society in the above paragraphs it should seem self-evident that we cannot view them in a static sense. Change is all-pervasive. One has but to be slightly aware of his environment to recognize the change going on in the world today. He would only have to investigate slightly further to become aware that the rate of change is increasing. Gow, Holzner, and Pendleton (1966, p. 160) point out this fact by saying, ". . . the images of society and of the world as fixed structures, so characteristic of earlier philosophy and theology, are being abandoned." They go on in this writing to say that there is a new view of man and society emerging in the world today based upon change as a constant.

Generally speaking, the principle mechanisms of social and cultural change have been defined as invention, acceptance of invention, and diffusion. LaPiere (1965) claims that the key to this change and the use of the mechanisms is within the individual. Timasheff (1967) says that culture can be defined as an accumulation of inventions from the areas of technology, ideology, and social interaction. This accumulation is unique for each society. He also sees a general agreement among sociologists toward the idea that technological and economic phases of culture change by means of accumulation, followed by setbacks. In the intellectual and esthetic realms these sociologists view change as both quantitative, up-and-down, fluctuations, and qualitative fluctuations.

From the foregoing it seems that the nature of society should be viewed from a change perspective.

## The Nature of Knowledge

Knowledge is man-made. It has only presence or absence in the minds of men. Man's perceptions provide him with individual opportunities to analyze and synthesize his experiences with his outer world. As Tyler (1964, p. 13) states, "All of it (knowledge) arises from the play of man's mind on his experience." Bruner (1964, p. 120) says essentially the same thing, "Knowledge is a model we construct to give meaning and structure to regularities we experience." McLuhan (1963) carries the ideas of perception and modeling even further. He contends that all areas of knowledge such as art, mathematics, science, and literature offer models of perception. He states, "It follows that any subject in our curricula can now be taught as a more or less minor group of models of perception favored in some past or present." (p. 16)

Throughout history man has sought to impart some order to knowledge that has become known to him. Aristotle attempted ordering by claiming that there were three major divisions of knowledge: the theoretical, the practical, and the productive. He assigned such disciplines as physics and mathematics to the theoretical, logic and political science to the practical, and fine arts and engineering to the productive. There have been many attempts to define specific areas of knowledge since Aristotle's days. One only has to investigate university catalogues to see somewhat arbitrary dividing lines being drawn between certain areas of knowledge.

The division of knowledge into areas of "disciplines" has been attempted by many scholars. Phillip Phenix (1958), Harry Broudy (1962), and Joseph Schwab (1964) have all proposed certain schema for the divisions or categories of knowledge. As an example, Schwab (1964)

points to three major groups of disciplines: the investigative (natural sciences), the appreciative (arts), and the decisive (social sciences).

There has not only been the problem of delineating as just described but the problem of what is really primary or prized is evident. There has been the Comptian type value-ordering in the sciences which starts with mathematics and then goes through physics and chemistry, to the biological sciences. The prizing has even been attempted through political bodies such as states. California, in 1962, listed academic disciplines vs. non-academic when considering the school subjects and the ensuing credentials given to persons trained to teach in these areas. Any visit to a college or university campus and inquiry as to the position and ranking of the sciences, liberal arts, and education on a list of scholarliness and importance would reveal a definite ranking.

Of recent inquiries into the nature of knowledge perhaps the most dominant has been the questioning of the structure of knowledge. In recent years many scholars both within and outside of the fields of education have concerned themselves with the concept of structure. In his book, The Process of Education, Bruner (1960, p. 37) relates his ideas concerning the structure of knowledge and importance to the educational process. To Bruner, knowing the structure of an area of knowledge or a discipline is knowing its basic principles and how they are interrelated. He states, "Grasping the structure of a subject is understanding it in a way that permits many other things to be related to it meaningfully. To learn structure, in short, is to learn how things are related." Through this relatedness a person is able to

order his experiences with the world and thus provide meaning to himself. Bruner (1964, p. 120) also comments,

The organizing ideas of any body of knowledge are inventions for rendering experience economical and connected. We invent concepts such as force in physics, the bond in chemistry, motives in psychology, style in literature as means to the end of comprehension.

Several other persons, such as Schwab (1964) in the sciences, Scriven (1964) in the social studies, and Wilson (1964) in English, have pursued this approach in attempting to define the structure of the disciplines. The work done by the Joint Council on Economic Education in recent years has been toward delineating the structure of their discipline.

Two other concepts have subsequently been developed in dealing with the nature of knowledge. The first concept deals with the structure of knowledge being a dynamic rather than a static thing and the second concept deals with the unitary and interrelated nature of knowledge. Miel (1963) contends that viewing structure as a set of interrelated principles is only the first step to understanding the nature of knowledge. She comments,

While such knowledge, even though static, is preferable to isolated bits of information lacking any system of organization, it stops considerably short of being the essence of a field of knowledge. (p. 81)

She sees the inquiry by scholars as producing an ever-changing structure. The viewing of the structure of knowledge as being in a constant process of evolving gives us new perspectives on the nature of knowledge. It seems as though through this perspective we would be viewing the structure of knowledge more as a verb than a noun, as a process rather than a condition.

Tyler (1964) continues this theme. He views the nature of knowledge arising from observations. Through the explanation of these observations by means of generalizations or abstractions knowledge is acquired. Each succeeding observation, from experience, will alter the abstractions, thereby changing knowledge in a continuing process. He says, "In that sense knowledge is always a growing product of man; it is not an object of specific experience and it is not static." (p. 15) Ausubel (1967) takes somewhat the same stance as he differentiates between what he terms the logical and psychological structure of knowledge. He claims that the environment contains materials having potential meaning and the individual converts this into differentiated cognitive content through psychological structuring.

Tyler (1964) has also been concerned with the interrelationships of knowledge. He proposes three types of knowledge. One type is the knowledge that grows out of man's efforts to devise ways of doing things effectively. Another type of knowledge results when man tries to make sense out of things and experiences that seem incomprehensible to him. The third type of knowledge arises from man's sensitivity to and production of feelings. Tyler provides a strong argument that learning should be approached with a view that these three types of knowledge are interrelated and we must maintain a balance of experiences that provide for acquisition of all three types of knowledge.

Perhaps one of the most intriguing and interesting proposals on the nature of knowledge has been advanced by Marshall McLuhan. McLuhan contends that we are entering an era where the structure of knowledge has spatial relationships that it did not have in previous times. With the invention of the printing press man was placed in an experiencing

situation that was linear and sequential and could come through only by perceptions of the eye. With the inception of the electronic age there has been an opening up to the reception by the ear and other sense organs. With these increased sensory avenues man is now able to perceive depth or structural knowledge. This in turn allows man to create a field of awareness rather than a static point of view. McLuhan (1963, p. 69) states, "We can now deliberately create total field situations which hold the usual structural consequences in abeyance." The human mind then can allow free interplay of models of perception and knowledge which can provide a new depth awareness of existing structures of knowledge. This, concludes McLuhan, will allow the educational process to shift from the imparting of information to the critical training of perception.

What McLuhan seems to be saying is that subject matter "content" can no longer exist separate for the process. Process is content and a central entity does exist that we cannot separate. He states (1963, p. 66):

The idea of content of education as something to be lodged in the mind as a container thus belongs to the pre-electronic phase and to the era of Euclidean space and Newtonian mechanics. A structure cannot be contained. Any conceivable container is at once part of the structure, modifying the whole.

### The Nature of the Learner

The human organism is exceedingly complex and is built upon the unit of structure called the cell. The human cell, with certain exceptions, contains a nucleus which holds genetic materials. These genetic materials in turn control the cell activities which allow life to be maintained. Specialization of cells provides for tissues and organs

which carry out the processes of life. The chromatin material of the nucleus arranges itself into various patterned structures called chromosomes. The number of chromosomes for various species of plants and animals is unique and constant. The chromosome number for humans is forty-six. Throughout all cellular structures in the human body, except for reproductive cells, forty-six chromosomes result from any cell division. In the reproductive organs of human beings the cells undergo a process of chromosome reduction termed meiosis in which the chromosome number becomes twenty-three instead of the usual forty-six. In each human sperm and egg there are twenty-three chromosomes. Each of these chromosomes has particular areas of its structure devoted to particular combinations of amino acids linked together. These areas and their structure are termed genes. It is the genes that control the inherited characteristics of human organisms. Stern (1960) assumes that there are approximately ten thousand pair of genes in the chromatin material of a human cell. When a human sperm fertilizes an egg these genes are paired up and this recombination results in returning the chromosome number to forty-six. With the great number of genes and the infinite ways in which they can line up, a situation exists that produces human organisms that are absolutely unique while at the same time insuring that the fundamental characteristics of humans will be present. The similarities which we all inherit are fairly well agreed upon by most persons including La Barre (1954). He lists a hip structure that allows bipedal locomotion, stereoptic vision, hands with opposing thumbs and a mental capacity superior to all other species as characteristics common to all humans. Butler (1954) adds the trait of curiosity to this list.



The differences which we inherit are centered upon the actual structure of the organism itself and are subsequently exemplified by the functional capacities of those structures. We do inherit sex through the way the chromosomes align. We inherit body structures and characteristics such as height, skeletal structure, and muscular structure which also determine appearance. Internal organ structure is also inherited. Baller and Charles (1968) list the inherited functional tendencies which result from inherited structures as follows: neural responses, sensory efficiency, internal system operation, rate of physical growth, and predisposition to certain diseases. Although inherited differences are present in each individual most all investigators in this field agree that these inheritances provide the individual with just the basics and it is the interaction with the environment that allows a person to express the potentiality from these inheritances.

✓ The learner is involved in the process of growth before and after birth. The single celled zygote, or fertilized egg, develops into a multi-celled organism capable of carrying out most of the life processes by the time of birth. Both growth and size and specialization is accomplished during the fetal stages.

Human organisms have sequential patterns in post-natal growth that exhibit certain characteristics peculiar to the species. In the period of infancy there is a rapid increase in size and weight. Physiological operations follow a pattern during this period. The child holds his head erect, sits up, crawls, and walks in order. Other operations involving individual and uncommon skills, such as throwing a ball, can be developed through training, however such activities as walking and

toilet training develop in their own good time. Medinnus (1969, p. 108) comments:

Neither special stimulation nor deprivation of experiences, within fairly wide limits, appears to influence the development of those behaviors that are phylogenetic or common to all members of the species.

The period approximately from 2-10 years which can be described as childhood is characterized by fairly stable growth rate. Sex accounts for differences in growth rate in the next stages termed adolescence. Physiological changes in the endocrine and reproductive systems occur earlier in this period for girls than for boys. Maximum growth is reached in late adolescence usually from sixteen to nineteen years of age. In the human adult cellular reproduction is directed toward repair or replacement of portions of the body.

Physical maturation for children in the United States has been speeded up in recent years as Tanner's (1968) studies show.

The complementary relationship between physical and mental growth and development has been consistently stressed. Baller and Charles (1968, p. 237) express this viewpoint by stating:

The child's rate of development and his size, shape, appearances, and strength help to determine the psychological situation in which he finds himself. His perception of himself and reception accorded him by others is a product in large part of his physical status, and his readiness to learn is to a degree a product of his maturity.

As he grows the human organism engages in the process of becoming aware of his environment. The process is facilitated by the use of his sense organs. By means of stimuli from these organs the person is able to identify and differentiate objects and happenings in his environment. It is this identification and differentiation which leads to the awareness that we may term perception.

From infancy through adulthood the nerve endings in the eye, ear, nose, skin, and brain provide humans with a multitude of stimuli. The being is actively engaged in organizing and ordering his world from these stimuli.

Once environmental objects or happenings have been perceived, reoccurrence will bring forth a state of expectancy within the person. For example, if an infant interacts with a red, round object through sight and touch, when he encounters it again in his perceptual field he will expect the object to have the same characteristics that it had in the first encounter. Thus, past experience influences our perceptions. Ittleson's (1952) report of the research of Adelbert Ames tends to confirm this view. Ames had constructed a distorted room and exposed subjects to it. Past experiences led to incorrect perceptions of the room and the subjects had to test the new environment in order to perceive its true character.

According to Kelly (1962) perception is also selection. We do not see everything in our surroundings but choose that which suits our purpose. Combs (1962) adds another dimension by claiming that we perceive that which will satisfy our needs. A person's need has a focusing effect upon perception.

The perceptions that are developed are unique to each individual. Not only do sense organs vary from person to person but an individual's record of past experiences is unique. When an individual is perceiving these two factors determine the final perception at that moment. It seems that perceptual growth of the learner can greatly influence his nature.

Throughout his development the learner exhibits certain states of behavioral expressions that are termed emotions. Physiological changes such as eye pupil dilation and palm sweating accompany these stages. In one of the early studies on emotions Watson and Morgan (1917) claimed that there were innate emotions and they were fear, rage, and love. Later Bridges (1930) theorized that all emotions come from a common source which she called excitement. From excitement came either distress or delight. Distress further became more specific during an individual's maturation and developed into jealousy, anger, disgust, and fear. Delight, in turn, was more specifically designated by joy, elation, affection for adults, and affection for children.

Emotional development varies from person to person. Although certain emotions are innate, through learning and conditioning individuals develop unique emotional characteristics. To this point Baller and Charles (1968, p. 166) state:

By indoctrination, imitation, instruction, and trial and error responses to situations, certain emotional responses, within the limits of his inherent capacity, are expressed, and by the process of conditioning are learned and become truly a part of him.

The pattern of emotional responses that the learner exhibits reflects his basic nature.

The nature of the learner is strongly influenced by his relationship with other human beings. The family exerts strong pressures upon the individual especially early in his life. The peer group influence is a vital factor in the childhood, adolescent, and adult years. Socio-cultural factors are constantly pushing and shaping the learner as he develops.

For a period of about five or six years the family provides most of the experiences through which a child relates with others. It is here that the structural basis for personality, attitudes and manners of operating with his environment is developed within the child. Blackham (1970, p. 40) contends that any changes after this period are exceedingly difficult to come by and he states, "Certainly human beings can change. However, they rarely change significantly after the first six years." The interaction, close relationships, and uniqueness of the family setting exert strong forces upon the learner in his development. Parental behavior patterns, and attitudes are vital factors in parent-child relationships. Many of the research studies on these factors have concentrated on the autonomy or democratic dimension versus the control or autocratic dimension. The Symonds studies (1949), the Fels studies (Baldwin, Kalhorn, and Breese, 1945), and the Pattern study (Sears, Macoby, Levin, 1957) have focused on these dimensions. The parent-child relationship is complex and it has been difficult to come up with simple and precise statements regarding the interaction; however, the above mentioned studies and others point to the warmth of the relationship as the most significant aspect in the development of the child.

The learner is influenced by age-mates as he leaves the environs of the family and moves out into situations such as play and school. With age the amount of interaction with others increases. In early childhood there is a great degree of conflict among peers. As the learner obtains the necessary social skills this conflict decreases. Havighurst (1952, pp. 17-18) states, "The process of learning to get along with age-mates is really the process of learning a social

personality . . . ." Havighurst asserts that this is a very fundamental developmental task which the growing child must accomplish. Individual learners manage this process of getting along in varying degrees.

The peer group replaces the family to some degree as the reference group for the child. As he matures into adolescence peer pressure becomes very strong. At this time the peer groups provide social status, acceptance, and social satisfaction for the individual.

The learner grows and develops within a cultural and societal setting. The patterned way of life of a society, termed culture, influences the language, ways of believing, food habits, attitudes, and values of an individual. A complex society such as exists in the United States contains many subcultures. The learner is influenced not only by the culture and subculture but by the social group to which he belongs. Within societies, hierarchies exist in rank or order. While not all persons agree upon the number of social classes within the society they do agree to the idea that they are conceptually discrete.

The learner's attitudes, values, aspirations, and patterns of behavior will differ according to the social class setting within which he finds himself. The community reflects that segment of society which exerts pressures on individuals that are probably the most powerful next to the family. Medinnus (1968) lists other forces from the socio-cultural background which assist in determining the nature of the learner. These are, the voluntary associations, the church, and the mass media. To this list must certainly be added the school.

What is the nature of the learner with respect to intelligence and thinking? With due regard to the many definitions of intelligence it is assumed that all human organisms possess it to some degree.

Terman's (1916) classic definition of intelligence as the individual capacity to think abstractly and use abstract symbols is perhaps the most time-honored definition. Guilford (1959) added the dimension of creativity to the definition. Cattell (1957) distinguished intelligence to be of two types, fluid and crystallized. Fluid intelligence he defined as that which solves novel problems and is innate in character. Crystallized intelligence on the other hand is that which is acquired by culturally influenced activities and skills.

From these and other definitions intelligence has been viewed by scholars in the field as either being totalistic in nature with an individual possessing intellectual abilities across the board, or as being factoral in nature having several factors which go to make up intelligence. A third view which encompasses both of the above perspectives attributes an individual to have some basic or general intellectual capacities as well as some specific categories of capabilities.

Jerome Bruner (1960, p. 37) states,

Research on the intellectual development of the child highlights the fact that at each stage of development the child has a characteristic way of viewing the world and explaining it to himself.

This viewing and explaining may be looked upon as a process of representation termed thinking. As the learner develops his thinking process is undergoing changes. Much attention and investigation has been focused on this process in recent years. Jean Piaget's contributions in this area are probably the most prolific and most thought provoking. Piaget (1960) sees the organism in interaction with the environment striving to establish and maintain equilibrium. By assimilation the organism influences his environment and by accommodation the environment influences the organism. By using these operations the child

comes to know reality. Piaget claims that youngsters from birth to adolescence go through four stages of development with respect to intellectual tasks. These stages he termed sensori-motor, pre-operational, operational, and abstract. The fundamental assumption is that these stages are invariant and sequential. Although he has listed general age categories for each, these ages are subject to much fluctuation.

Other aspects of the nature of the learner's thinking that have prompted investigation are: the nature of problem solving, the nature of productive thinking, and the nature of creativity. A number of studies have shown that these factors are inherent in the thinking process of the learner.

The use of symbols to communicate is unique to humans. The nature of the learner is affected by his symbolic communication scheme or language. It is in the learner's nature to proceed from a simple beginning to a highly complex communication pattern.

The infant's sounds are primarily those of crying and babbling. He then proceeds to consonant or vowel phonemes. Just how the infant attaches meaning to sounds is not clear, but some investigators such as Mower (1950) believe that it comes through the emotions or feelings. From repeated sounds and through meaning come the child's first words. In constructing the words the child has made combinations of sounds called morphemes. He learns to sequence these morphemes according to the language which is spoken. Finally he uses syntactical patterns to produce sentences or phrases. A child's vocabulary increases tremendously during the period of one to six years. Although children enter school with a several thousand word vocabulary there is a great



variability between individuals both in the quantity of words and ability to use them in the communication process. There are a number of factors to which this variability can be attributed. The parents' attitude toward language as well as their education, occupational, and socio-economic levels are vital factors. Baller and Charles (1968, pp. 310-312) list other more individual factors in language development to be motivation, sex, racial and ethnic background, health, and intelligence.

Finally, the nature of the learner is exhibited by those observable characteristics of his person which make him unique. This uniqueness is what we may term an individual's personality. Personality has been defined by Heffernan (1952, p. 37) in the following manner:

By personality we mean the thinking, feeling, acting human being, who conceives of himself as an individual separate from other individuals. The human being does not have a personality; he is a personality.

The personality springs from two main sources. The biological source provides a genetically directed physiological structure which is unique for each person. Williams (1960) has presented a strong case for the individuality of a single human organism and for the uniqueness of the organism's individual parts. He states,

Consider the fact (I do regard it a fact and not a theory) that every individual person is endowed with a distinctive gastro-intestinal tract, a distinctive nervous system, and a morphologically distinctive brain; furthermore that the differences involved in this distinctiveness are never trifling and often are enormous. Can it be that this fact is inconsequential, in relation to the problem of personality differences?

The other source of personality is the experiential force that is derived from an individual's interaction with his environment. Carl Rogers (1962, p. 22) in commenting upon the influence of experience

upon the personality says, "The self and personality emerge from experience . . . . It means that one becomes a participant in and observer of the ongoing process of organismic experience . . . ." Rogers accepts the inherent structure idea but feels that in the process of becoming a person it is the experiential base that allows an individual's genetic potential to develop.

Personality develops from a relatively simple to an extremely complex phenomenon as a person grows from infancy to maturity. Most investigators of personality development agree that early experiences, usually up to five or six years of age, are strong determiners of later personality characteristics. Erickson (1950, pp. 219-231) has postulated that there are eight stages of personality development each of which is characterized by its own goal. They are as follows:

- Infancy: a basic sense of trust
- Earl childhood: a sense of autonomy
- Play age: a sense of initiative
- School age: industry and competence
- Adolescence: personal identity
- Young adult: intimacy
- Adulthood: generativity
- Mature age: integrity and acceptance

In a survey of the literature concerning personality characteristics there are several characteristics which have been the prime targets of investigation. Medinnus (1968) sums up the list of these with the following: dependence-independence, aggressiveness, anxiety, development of conscience, dominant-submissive behavior, and social acceptance.

There is strong evidence that the exhibition of a behavior pattern by an individual is determined to a large extent as to how he views and feels about himself as a person. This concept of self begins in infancy with the child determining what is "me." His first determinations are those concerning his body. As he grows and other persons come into his life their views about him are mirrored back into his consciousness. All of these reflections, which are learned, assist the child in evaluating himself. If this concept of self is positive the individual will have a pleasant and successful existence. He, according to Combs (1962), becomes an adequate person who can take advantage of his life experiences and make the most of them. He can meet life expecting to be successful and then in the process of becoming a person can realize much of his basic potential.

From the foregoing paragraphs it is evident that the nature of the learner is determined and influenced by: a genetic base, growth and development patterns, perceptions, interaction with others, language, psychological capabilities, and basic drives and emotions. The learner then develops into a unique person with feeling about himself.

### The Nature of Learning

Human learning is characterized by its complexity and its controversy. Thousands of men have tried to unravel its complexities for many centuries. Throughout this endeavor many controversies have arisen, many of which are currently raging at the present time.

Man's early explanation of learning was tied to his beliefs about supernatural powers and what might be termed divine revelation. Learning, it was thought, came about through man's connection with the gods

or stars. Even Plato's doctrine of innate ideas espoused the belief that nature, or God, had provided man with perfect knowledge before birth. Man's experiences were then just a way to unfold these innate ideas.

Aristotle saw man as having a soul that contained certain sections or faculties. One of these he described as the thinking faculty. John Locke, says Peter Gay (1964), took Aristotle's ideas and promoted the thought that man's learning could be developed through the use of his mental faculty. Locke's views are classified as those of an empiricist and consequently became the separation point from earlier views regarding man's learning as arising from supernatural powers.

The learning theory of mental discipline was derived from the above two views of the nature of learning. This classical approach contended that the human mind, if it is properly exercised, will develop truth or knowledge. The faculty psychology also contended that through the use and training of man's faculty for thinking he would come to know. Both of these views then adhere to the principle that through rigorous, sometimes distasteful, disciplining of the mind, learning will occur.

Both Hill (1963) and Venable (1967) point to the highly significant event of psychological thought turning to the laboratory as bringing about changes in thinking regarding the nature of learning. William Wundt, in 1879, opened the first institute of psychology at the University of Leipzig. Venable (1967, p. 66) comments, ". . . in the case of Wundt's institute the ideas, the methods of study, and the general intellectual atmosphere did change the world of psychology." With this change came changes in ways scholars viewed the nature of learning.

With psychology becoming more scientific and more objective in nature, focus was placed upon specific environmental stimuli and their effects upon the individual. Investigation was made as to the nature of a particular stimulus and how it was related to the particular response which followed. Learning theorists at this time generally proposed a direct causal relationship between the stimulus-response (S-R). Historically speaking many persons have followed this basic interpretation of human learning and have expanded upon it. Hilgard (1966) termed these persons as stimulus-response theorists. Hill (1963) describes those persons of this particular school as connectionists. Bigge (1964) labels them as stimulus-response associationists.

There are many outstanding men that have aided in the stimulus-response interpretation of learning but perhaps the ideas of Thorndike, Watson, Guthrie, Hull, and Skinner cover the major propositions most completely.

Edward L. Thorndike (1932) proposed a theory that has been called connectionism. He believed that learning is based upon the formation of a bond between the stimulus and the ensuing response. Through trial and error practice this bond is strengthened and learning, according to Thorndike, has taken place.

John B. Watson (1930) held strong views regarding learning as conditioning from environmental stimuli. Taking off from Pavlov's classical conditioning theory Watson claimed that we can build a complex series of responses as new stimuli are introduced. This results in what he termed conditioned responses. In addition an individual in order to learn must develop new responses through a series of reflex acts. It is this responding to a serial combination of

simple reflexes which results in new behavior that is termed learning.

Edwin R. Guthrie's (1952) explanation of learning proposed that it was the association between the stimulus and the response that resulted in learning. One trial allows this association to be fully formed; however, each learning situation presents a slightly different combination of incoming stimuli. Correct responses need to be developed for these stimuli and the more practice or drill results in more correct responses and this results in more learned associations. It is these learned associations that lead to a changed behavior described as learning.

The latest expansion of the S-R theory of learning proposes the response to be the critical factor in learning. B. F. Skinner (1953) theorizes that by controlling the environment with reinforcers a person's behavior can be shaped. These reinforcers strengthen the response and, to the degree they do, result in the learning that occurs. Skinner has identified an operant as a set of responses. By conditioning this operant with reinforcers persons can learn. Therefore the control of the environment is the crucial factor in assuring that an individual will learn.

The interpretation of the nature of learning has followed another direction due to the theories and research of such men as Wertheimer, Kohler, Koffka, Lewin, and Tolman. As opposed to the S-R type theorists these scholars have been classified as cognitive theorists by Hilgard (1966) and Hill (1963) and as gestalt-field theorists by Bigge (1964). Generally speaking the cognitivists assume that an individual learns by organizing his stimuli into wholes or patterns. There are relationships between the stimuli that the individual is able to

perceive. This perception occurs against a background or field. These theories also propose that the individual is goal directed and has the ability to develop a sudden solution to perplexing situations. This latter ability is termed insight by the cognitivists.

Max Wertheimer first advanced the idea of gestalt psychology based upon the concepts of figure and ground. The figure is the thing we perceive while the ground is the undifferentiated background. Even though there are separate parts which a person perceives in his environment it is the whole pattern or gestalt that gives him meaning. This whole according to the cognitivists is greater than the sum of its parts. Wolfgang Kohlers' experiments with apes in problem solving situations brought attention to the concept of insight as a part of gestalt psychology.

Kurt Koffka's contributions to gestalt theory consisted mainly of relating the central assumptions to the learning act. According to Koffka (1935) it is the organizing and reorganizing by the individual in interaction with his environment that brings about learning. Individuals, claimed Koffka, perceive things in groups according to their proximity to each other as well as likeness to each other.

Edward C. Tolman contributed what has been termed by Hill (1963) as purposive behaviorism. Tolman believed that an individual perceives the nature of the situation through signs or cues as he struggles to solve problems on his way to achieving his purposes or goals. The behavior he exhibits identifies the learning that has occurred. Tolman was concerned with this behavior only in its molar form. By molar form he meant large behaviors as opposed to minute responses as most S-R theorists would identify.

Kurt Lewin expanded gestalt field views of learning with his concepts of life space and motivation. Lewin conceived life space to be a two dimensional space in which the individual lives and moves. One dimension consists of the internal forces exerted upon the person such as physiological and psychological forces while the other dimension is composed of other persons and stimuli from his environment. The interplay of the two dimensions according to Lewin determines the behavior of the individual. Lewin also stressed internal goal definition as the prime source of motivation.

From the above descriptions of major contributors to learning theory it is evident that there is a polarization between behavior theorists and cognitive theorists. Hilgard (1966) says there are three main cleavages between the two explanations of the nature of learning. The first Hilgard identifies as the difference between "peripheral" versus "central" intermediaries. Peripheral means that responses or outside movements provide the inferences for learning while to the cognitivist central processes such as memories or expectations serve as stimulators for behavior. The second cleavage revolves about acquisition of habits versus acquisition of cognitive structure. The behaviorist says that habits are what is learned while the cognitivist asserts that cognitive structures are what is learned. The third cleavage results according to Hilgard, when behaviorists contend that trial and error is the mode for problem solving while the cognitivists claim insight to be the mode.

Even though the S-R theorists and the cognitive theorists represent the two major views of the nature of learning they do not reflect all of the interpretations. Many other investigators have branched off



from the two directions and proposed other models of learning.

Miller and Dollard (1950) relate learning to personality theory when they contended that the four elements of learning are drive, cue, response, and reward, while Estes (1959) attempted to describe learning by means of a statistical model.

In a branch of psychology called genetic psychology Jean Piaget views thinking and subsequent learning as a developmental process. According to Piaget (1969) there is a definite sequencing of the learning process through stages in an individual's maturation process. He identifies the first stage as sensorimotor, from birth to approximately two years of age, during which the child organizes spatial relationships and objects. In the second stage, preoperational, from two to six or seven years of age, the child is capable of having representational thought by means of symbolic function. The third stage, from about seven to eleven years of age, is termed the age of concrete operations. In this stage the child can classify, order, use numerical operations, and measure by means of concrete objects. The fourth and final stage is called the stage of formal operations in which the individual can use abstract hypotheses and from these can reach deduction by logical or formal means.

At least two theorists, Tolman (1949) and Gagne (1965), propose that there is more than one kind of learning. Tolman describes six kinds while Gagne claims there are eight kinds of learning. Gagne feels that these can be viewed in a hierarchial manner. In order from lowest type to highest he identifies these as: signal learning, stimulus-response learning, chaining verbal association, multiple discrimination, concept learning, principle learning, and problem solving.

Gagne then relates these types to the structure of knowledge.

The complexity, divergence, and multiplicity of explanation of the nature of learning seem to indicate that there is no single verified theory of learning to explain its nature. Ausubel (1966, p. 3) states:

. . . neobehaviorists have extended their views upwards to include the more complex cognitive processes, whereas their theoretical antagonists have extended their views downward to include simpler kinds of learning,

Even though this seems to be the case Hilgard (1966, p. 13) claims:

At the same time no one has succeeded in providing a system invulnerable to criticism. The construction of a fully satisfactory theory of learning is likely to remain for a long time an uncompleted task.

### The Nature of Values

We are in constant contact with values, either our own, or those expressed by others around us. It is very difficult to enter into any kind of communications with other human beings without values affecting our verbalization or behavior. Valuing becomes an inherent part of the person interacting with his environment from early childhood. We can view values from an individual perspective and from a sociological perspective when investigating groups either large or small.

Rokeach (1968) defines a value as a single belief guiding actions to end stages of existence. It is, according to him, an imperative to action. He further delineates values as instrumental and terminal. An example of an instrumental value would be a person saying he believed a certain mode of conduct (going to church) has value, while saying he believed that a particular end state of existence (salvation) is worth striving for, illustrates a terminal value. According to Rokeach, values are organized into a value system which is a hierarchical

structure with substructures that interact cooperationally. He sees four subsystems making up a value system: (a) a person's beliefs develop an attitude, (b) two or more attitudes make an attitude system, (c) an attitude system makes up an instrumental value while (d) instrumental value systems make up a terminal value system.

The above analysis of the relationships between attitudes, values, and value systems provides the underlying rationale for value change. It is characteristic of individuals to try to maintain a consistency in their value system. Insko (1967) lists eleven theories on attitude change several of which deal with value change. Perhaps the most widely disseminated theory is Leon Festinger's theory of cognitive dissonance (1962). Rokeach (1968) also proposes a theory of dissonance. The main premise advanced is that if you bring about inconsistency within a person's attitude-value system it will require cognitive reorganization to regain consistency. Rokeach cites a study involving college students with the values of equality and freedom. After inducing dissonance the students were to reflect their values at the end of three weeks and at the end of three months. The results showed an enduring change of values. Other studies of a similar nature have given support to the hypothesis that values can be changed.

In viewing values from a sociological perspective it is evident that values can be made specific and effective through norms. Institutions in the societal group represent internalized values. Williams (1965, p. 451) comments, "Stability of culture is therefore a dynamic process in which a delicately balanced set of values is maintained." With a full realization that it is extremely hazardous to define and delineate American values, Williams attempts to do so. He lists the

following as major value orientations in America: achievement and success, activity and work, moral orientation, humanitarian mores, efficiency and practicality, progress, material comfort, equality, freedom, external conformity, science and secular rationality, nationalism-patriotism, democracy, individual personality, and racism and related groups superiority theme. These value orientations are seen as highly complex and are in continually shifting and recombining configurations. Dahlke (1958) has a more modest list consisting of the following orientations: religious, activist, market-value, common-man, and humanist. He lines these up according to positions on such things as ultimate ends, competition, social change, war, etc. Perhaps the most outstanding thing concerning Dahlke's list is the difference between the orientations.

Smaller groups within a society also possess value orientations that are complex and diversified. Communities, especially smaller ones, exhibit recognizable value orientations. Political parties, the Ku Klux Klan, and Americans for Democratic Action are examples of groups having diverse value systems.

If values do give direction to actions both on an individual and group level their influence would be most pronounced upon those individuals that make up a school-community setting. The value system of each person is the guide to his behavior in the interactions that occur within the school itself.

## CHAPTER IV

### THE ELEMENTARY SCHOOL AS A SYSTEM

An elementary school is composed of parts. There are physical parts such as grounds, buildings, equipment, and materials. There are persons in roles of students, teachers, principals, parents, and supplementary personnel. What is of more importance is that these persons are persons outside of their role. These physical and human parts are in interaction with each other. Presumably, the elementary school is in existence to accomplish something with students. If a system is defined as a series of interrelated parts interacting to accomplish a previously determined goal, then an elementary school can be designated as a system.

The curriculum has been defined as a set of events, either proposed, occurring, or having occurred, which has the potential for reconstructing human experience. Curriculum development is then defined as the structuring and restructuring of the interaction that takes place in the curriculum. It is assumed that the nature of man, society, knowledge, the learner, learning, and values are the major components to be considered in curriculum development.

It is also assumed that curriculum development takes place in every elementary school's system to some extent; however, it may not pursue a course that is planned, reasonable, or logical. Theoretically, the curriculum development process can be analyzed and synthesized.

### Definition of Terms

In order to expand the systematic view of curriculum development it is necessary to define those additional terms that will be used in the statement of the theory and in the construction of the ensuing model. These terms are defined as follows:

Analysis - a generalized and logical process for breaking down a complex whole into as many carefully distinguishable parts as possible and determining how these parts are related to each other within the characteristic actions, patterns, and structures of the whole.

Environment - all of the external circumstances and conditions which affect an organism, and/or a system, at any stage of its existence.

Need - an identifiable differential which exists between "what is" and "what should be."

Need Assessment - the process for determining the relative importance, dimension, and value of a differential which exists between what is and what should be in light of the present state of knowledge.

Synthesis - a generalized and logical process for combining separate elements into a desired orderly whole after first identifying and determining the necessary actions, patterns, and structures required for desired performances.

Performance - the manner by which required functions and tasks are executed in accordance with self-selected or system-selected goals.

Design - the graphic representation which results from synthesis.

## Systems Concept and Techniques

Historically man has utilized the system concept in his interpretation of his environment. The solar system, the body system, including subsystems such as the circulatory system, and mechanical systems have all served man in his quest for knowledge about the world around him. The educational system can be analyzed in order to determine the nature of the system's structure and process. This analysis can best be accomplished by viewing the system as a gestalt-like whole.

The previously stated definition of a system may be expanded to include the view that the system is greater than the sum of its total parts. The interaction process imparts characteristics to the system that are not present when the parts are viewed separately.

Just as any system may be considered a subsystem of a larger system, a particular system itself, is composed of subsystems. The environment of any system is by definition external to, provides inputs to, and receives outputs from the system. Figure 1 represents a typical system with its interacting parts, environment, inputs, and outputs. Outputs are shown as becoming a part of the environment and as such are included in the inputs back into the system.

If the elementary school exists and if it has as its purpose the accomplishment of some goals, a highly complex problem is presented when we try to determine what is actually being accomplished. The purpose of a system analysis is to analyze the problem and to set directions for its resolution. This educational problem-solving effort should be aimed at problems which are valid. The validity can be determined through an analysis of the system itself.

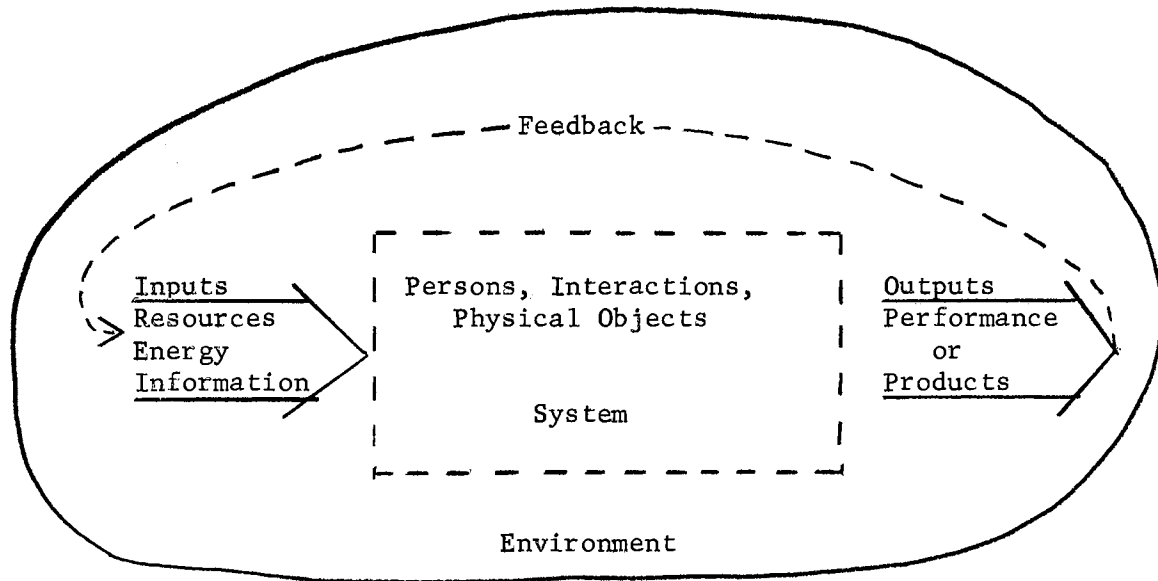

Figure 1. A System

A systems analysis proceeds through four steps: mission analysis, function analysis, task analysis, and methods-means analysis.

Mission analysis consists of four elements: the mission statement, the required performances, the constraints, and the mission profile.

The mission statement is a precise statement of the over-all job to be accomplished. It identifies the big WHAT is to be done. In order to have clarity, the mission statement must determine:

1. What is to be done
2. Where it is to be done
3. When it is to be done
4. How well it is to be done

Probably one of the most fundamental requirements of a mission statement is that it clearly communicates and leads to an understanding between all of those persons involved in its accomplishment. A mission



statement which is concerned with curriculum development must focus on the learner.

The performance requirements establish the criteria for the success or failure of the mission. In actuality the specification of output performances provides the measuring instrument for the mission's success. These specifications may spell out the quality and/or quantity of the outputs. Where the outputs can be measured the performance requirements should state explicitly the level which will be acceptable for accomplishment of the mission.

Constraints are identified as those already existing boundaries and restrictions which may hamper or prevent the accomplishment of the mission. Monetary resources, personnel, and laws are examples of the most common constraints upon an educational mission. It is necessary that as many constraints as possible be identified before proceeding with a mission analysis.

Having analyzed the mission statement, the required performances, and the constraints we have a known entity. The important question now becomes what must be done to accomplish the mission? In other words, what steps must be taken for the accomplishment? It is important to note the difference between what is to be done as compared to how to do it. Under no circumstances in mission analysis are we to be concerned with the how. The major jobs to be done to accomplish a mission are termed functions. These functions must be identified and then sequenced. The resultant product of this identification and sequencing is a mission profile. Figure 2 illustrates the relationship of the functions to the mission and portrays a mission profile.

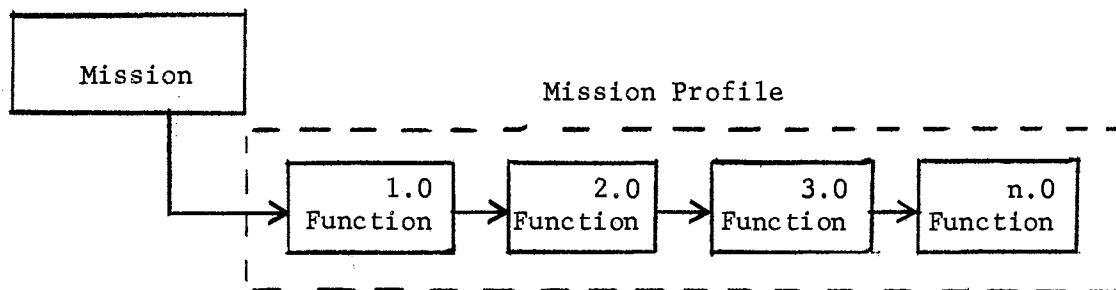

Figure 2. Mission Profile

When the major functions of a mission profile have been identified they should be re-examined by checking back against the mission statement, the required performances, and the constraints. This checking back is termed iteration. Actually iteration is an on-going process which insures internal consistency within and between functions and between the functions and the mission. Iteration should take place throughout all the phases of analysis of a system.

When the mission profile has been developed we have completed the first step in function analysis. At this point it would do well to establish some procedural rules to be followed when using systems techniques. In Figure 2 by placing the functions below the mission we are operating in a vertical plane. By placing the functions in a serial manner with a line connecting them we are operating in a horizontal plane. Further development of the design proceeds according to these planes, As we drop down vertically we are analyzing the lower level or smaller jobs to be accomplished. A decimal numbering system is used to determine the level of the ensuing actions. Figure 3 illustrates the above points.

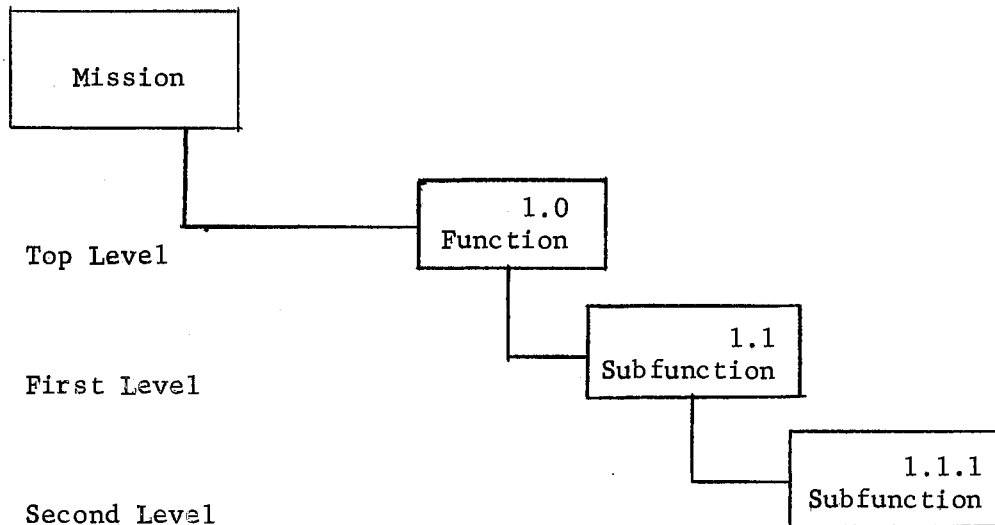

Figure 3. Vertical Stepdown

As we proceed in function analysis we determine what has to be done in order to accomplish the function. These "whats" are termed subfunctions. In this determination we may find that there are parallel or alternate paths to be taken. Figure 4 illustrates this point. The broken line with the arrows indicates the feedback iteration process. Function analysis continued until all the functions which are necessary for accomplishment of the top level functions are analyzed. The thinking process remains concentrated on what is needed to be done. The description of the function is always done by action words such as: provide necessary equipment, assess needs, determine population, etc.

After function analysis has been performed the next step is to conduct a task analysis. According to Gagne (1965, p. 12) a task may be defined as "the smallest component of performance which has a distinct and independent purpose." Emphasis here is still upon what tasks must be performed in order to accomplish a subfunction. Tasks form the

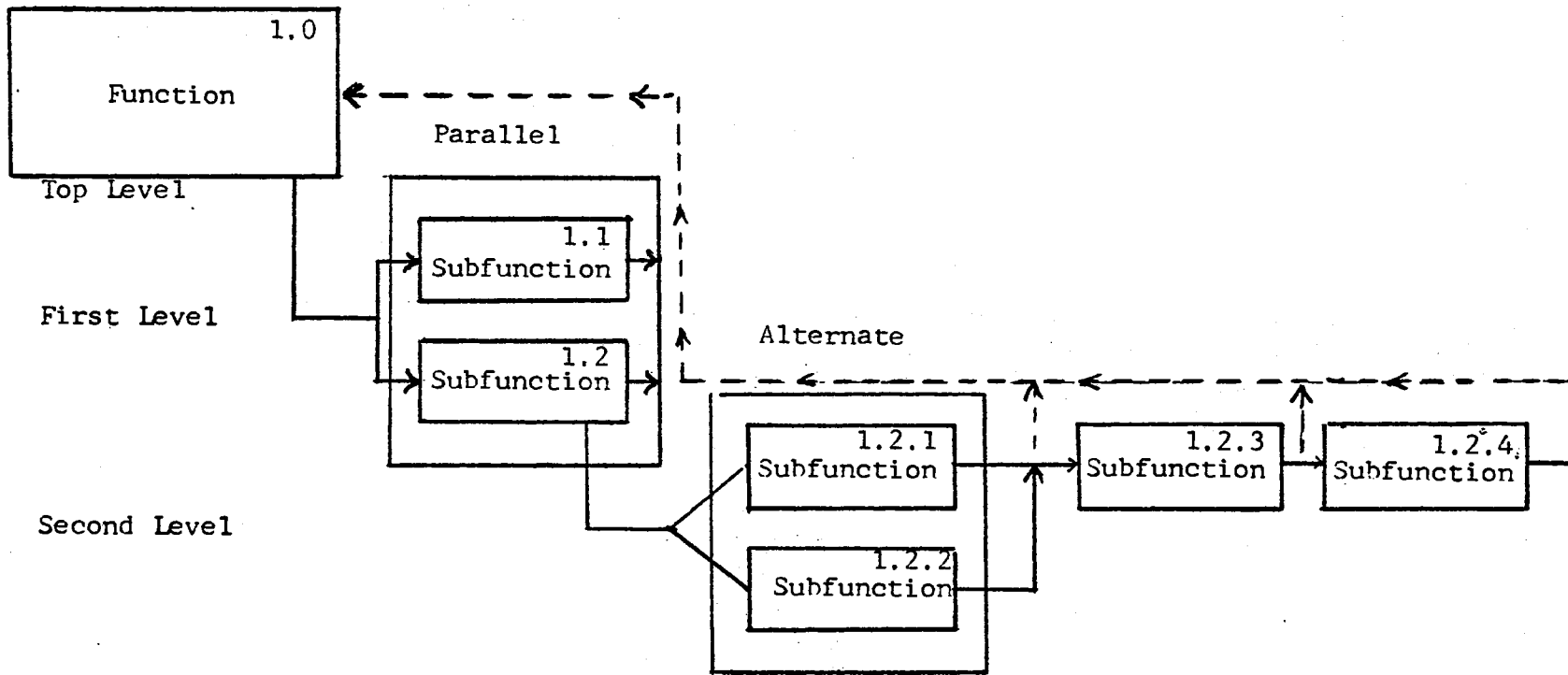

Figure 4. Parallel and Alternate Paths

lowest level of what is to be accomplished in system analysis and must be analyzed in terms of the actual requirements necessary to complete the task. If, from Figure 5, we consider the task of distributing the materials to students we would need to know what materials, how many, to which individuals, when should they be distributed, and where should they be distributed. Sequencing of the tasks is of great importance in order to accomplish the subfunction in the most effective manner.

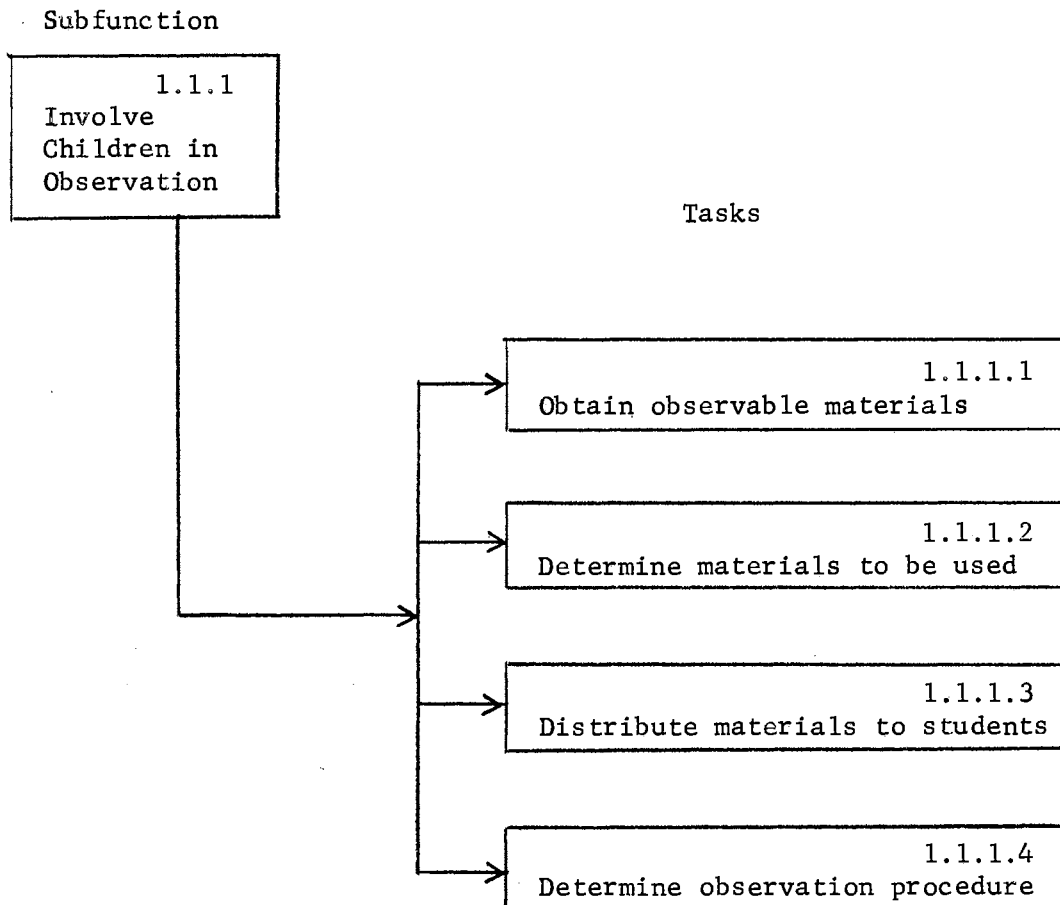

Figure 5. Task Analysis

The above discussion on mission, function, and task analysis concern has been centered on identification of what is to be accomplished in order to meet the desired performance which will in turn lead to mission success or failure. This collection of "whats" provides the data base for making decisions as to how things will be achieved. Methods-means analysis will provide the data that will make it possible to decide how to do whatever is necessary. A method can be defined as the strategy used for allowing a performance to be accomplished while a means is the vehicle by which a strategy is achieved. For example, if the desired performance is the understanding of a concept in mathematics, the method could be using manipulative materials, while the means could be a set of cuisenaire rods.

A methods-means analysis is the identification of all possible strategies and vehicles for achieving a desired performance. In system analysis, methods-means analysis is carried on concurrently with mission function and task analysis. Generally speaking the methods-means analysis will become more specific as one progresses downward through the analysis. Final methods-means possibilities are developed at the task level and are precise and specific. Figure 6 is a representation of the interrelationship described above.

In a methods-means analysis, selection of a particular "how" is not done, only an analysis of all possibilities is undertaken.

The system analysis provides all the necessary data to proceed to system synthesis. The statement of the mission, the identification of constraints and the function, task, and methods-means analysis provide the information that is necessary to solve the problems of accomplishing the mission. System synthesis is composed of three major

activities: determining the solution of the problem, implementing that solution and then evaluating the effectiveness of the solution. Graphically it can be represented in Figure 7.

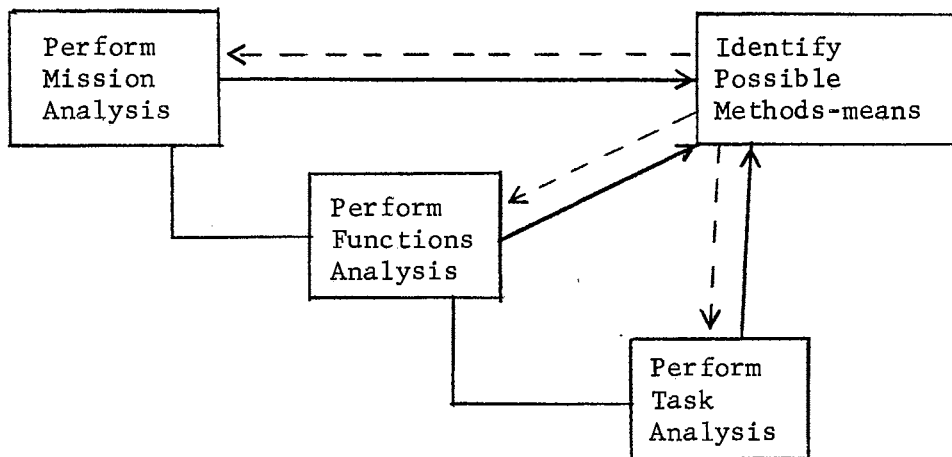

Figure 6. System Interrelationships

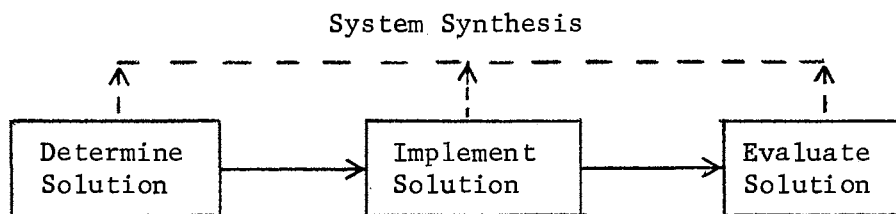

Figure 7. System Synthesis

The determined solution should provide an over-all framework for the synthesis operation. This framework is tentative and is subject to constant assessment. A tentative framework would propose the necessary methods, personnel, facilities, and resources necessary to accomplish the mission. The framework results from a reasonable and logical assessment of the entire analytical process.

After the framework is developed the next step in solution determination is the allocation of tasks and functions within the framework. This is a reverse procedure from analysis and provides for an ordering and sequencing of the tasks and functions. Allocations are made to specific areas of responsibility, to personnel, and to groups or divisions within the system.

3 The next step in solution determination specifies how the tasks and functions will be done. The data have been previously supplied by the methods-means analysis but at this point in synthesis, decisions are made as to exactly how things will be done. Decisions on the "hows" are based upon relevance, practicality, and effectiveness.

The second major step in synthesis is the implementation of the solutions. This is the actual combining of physical factors and human factors into an operation process directed toward accomplishing the mission.

The last step in synthesis is evaluation. Evaluation should determine how well the solutions are performing and what revisions are necessary to allow for more effective operation. Evaluation, which has been a constant procedure throughout the systematic process, should provide the answer to the vital question of goal alignment. Questions must be asked as follows: Are the performances in alignment with the



tasks that are being performed? Does the accomplishment of the tasks assure achievement of the function? Do the functions in their sequence and interaction lead to the accomplishment of the mission?

The systems process is involved with defining a problem, analyzing it, and then putting together a solution for the problem.

## CHAPTER V

### A CURRICULUM DEVELOPMENT THEORY

A theory is proposed for curriculum development in an elementary school utilizing previously stated assumptions, the nature of curriculum components, and systems theory.

This systematic theory is three dimensional with the dimensions being humans, physical objects, and interactions. Human beings are involved first as persons with feelings, emotions, and values and second in roles which they play in the setting. It is assumed that all persons in the system operate with a knowledge, belief, and value base and that every action or interaction is influenced by the individual's value system. Specifically, every component of the curriculum that has been previously designated (such as the nature of man, the nature of learning, etc.) is affected by the person's value system. If this is assumed, then every interaction within the system is affected by what we may term the nature-value force. This force will be designated throughout the system as NV. We assume this force to be a constant.

We also assume the elementary school curriculum development system to be an open system. As such, environmental forces are constantly affecting its operation.

Even in theory construction an individual is influenced by beliefs, attitudes, and values. The intention of this theorist is to remain

non-prescriptive; however, essential to the theory itself is a belief that man is an emerging, goal-seeking organism with unlimited potential.

#### Development of the Mission

Through an analysis of what an individual school is to do with and for students, a mission statement is developed. It becomes a written statement providing direction for the entire institution. It is by its very nature a statement of goals. The mission statement is made within a larger context which includes national and regional goals. If the elementary school is within a district with other schools, the statement is affected by the philosophy and goals of the larger entity.

An examination of the nature and characteristics of goals would seem appropriate to the development of the mission statements. The characteristic of multiplicity so aptly described by Etzioni (1964) should be recognized. The idea that goal determination is a dynamic process is of tremendous importance. Sills (1958) points out that goals are constantly in the process of succession while Thompson and McEwen (1958) speak to their dynamic qualities. The relationships of individual goals to the institutional goals will greatly affect the accomplishment of the stated mission. Participation by all persons affects the content of the mission statement.

The mission statement is therefore characterized by its tentativeness as it is not cast in bronze but should be subject to change as environmental forces act upon the system. Furthermore, a fundamental necessity is that the mission become and remain operational. Every action and interaction within the system is a direct consequence of the mission being in operation.

The mission statement for an elementary school could be developed through many different procedures, but it must be assumed that it would eventually represent the collective wisdom of those participating in its development as well as the NV constant of those participating.

The determination of constraints will identify those factors within which the system will operate. In the case of an elementary school these constraints would include the following: leadership capabilities, certificated staff number and capabilities, number of support personnel, physical plant characteristics, district policy and procedural definitions, and monetary resources.

#### The Mission Profile

This writer proposes the functions for a curriculum development system to be: the determination of student needs, the determination of priority needs, the development of strategies to solve those needs, the implementation of those strategies, and the evaluation of the strategies. The mission profile for this system is presented in Figure 8. Whatever the mission statement provides for the unique situation of a particular elementary school with its own environment these top-level functions are descriptive of what is to be done and in what sequence in order that the mission may be accomplished.

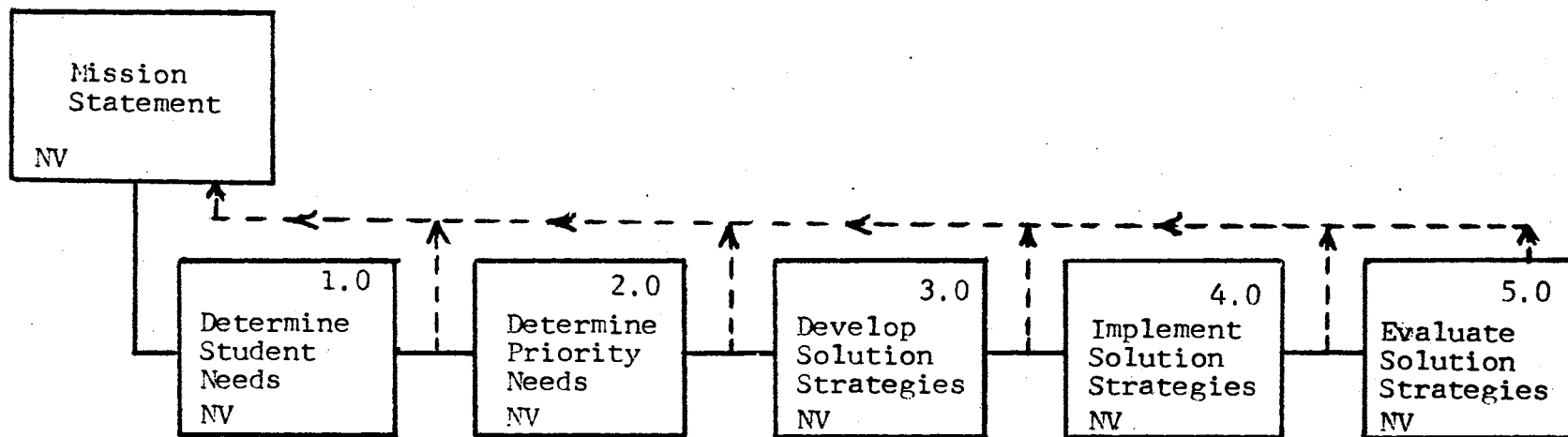

Figure 8. Mission Profile

## Function Analysis

The first function to accomplish the mission is to determine the needs of the individual learner. Every child has certain basic needs that, to some extent, are with him constantly and must be met if he is to develop into a fully functioning, adequate person. In addition there are other needs that a school should be aware of and take into consideration when developing a curriculum. These needs might be termed societal needs. In truth the child's needs are society's needs, but in the process of curriculum development the system must be sensitive to societal needs as expressed through sociological data. Figure 9 illustrates the break-out of the need determination function. The determination of needs has been broken down to the third level subfunction in this system. The level of breakdown and the subfunctions themselves would be different for each school due to the uniqueness of the environment and personnel. It can be seen that the establishment of a data base is of prime importance. The determination of the current status of curriculum-instruction program, subfunction 1.2, is necessary to eventually determine which needs are being met and to what degree. In Figure 9, subfunction 1.2.2, determines which curriculum development projects are currently in operation. It should be noted at this point that there is always a box left open at the bottom of each functional level. This indicates that the system is open and, depending upon the circumstances in a particular school, further subfunctions could be added.

Function 1.3 is the point at which a "matchup" takes place between the determined needs and the degree to which those needs are being met by current curriculum programs and are to be met by those in future

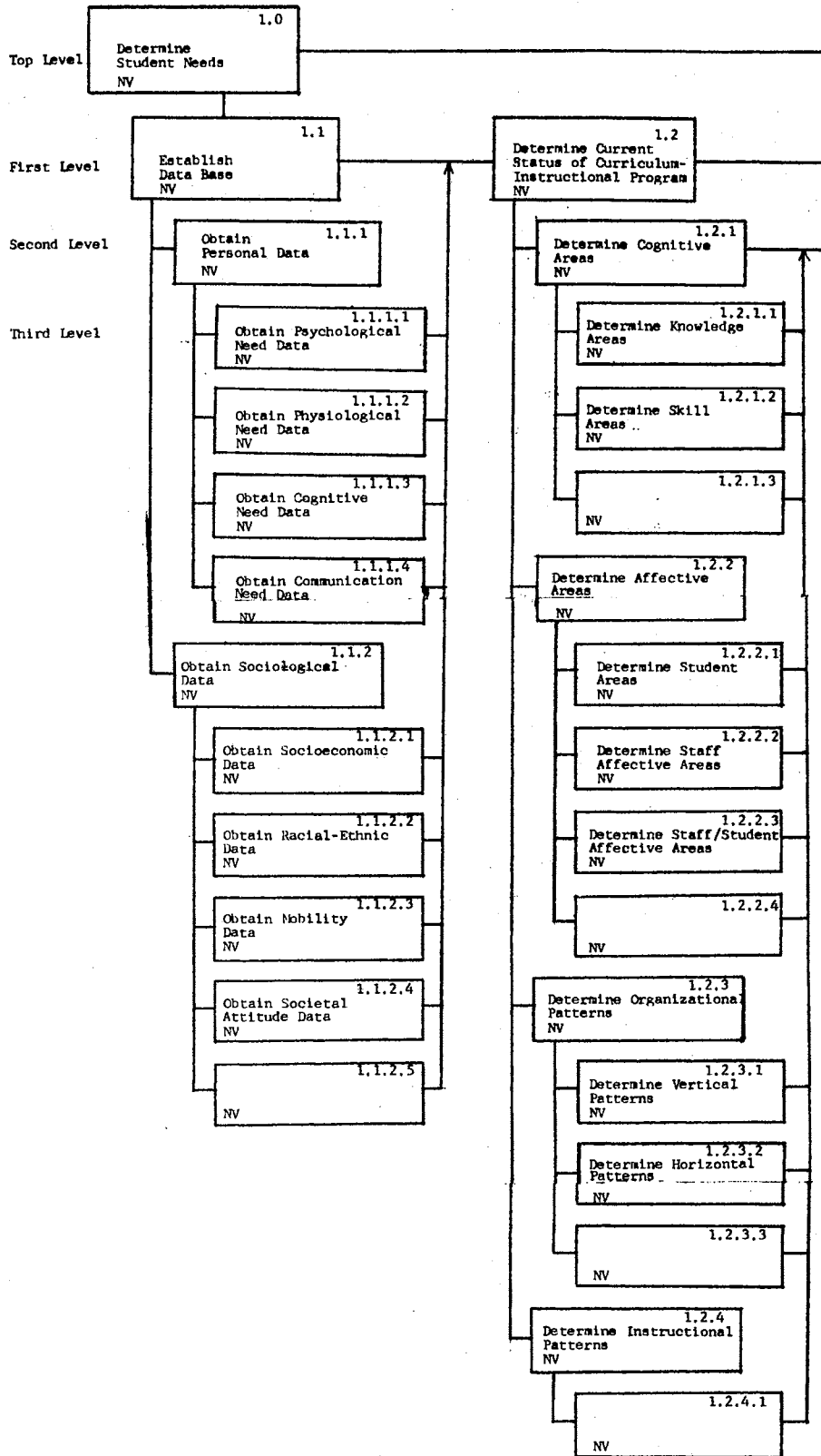

Figure 9. Need Assessment

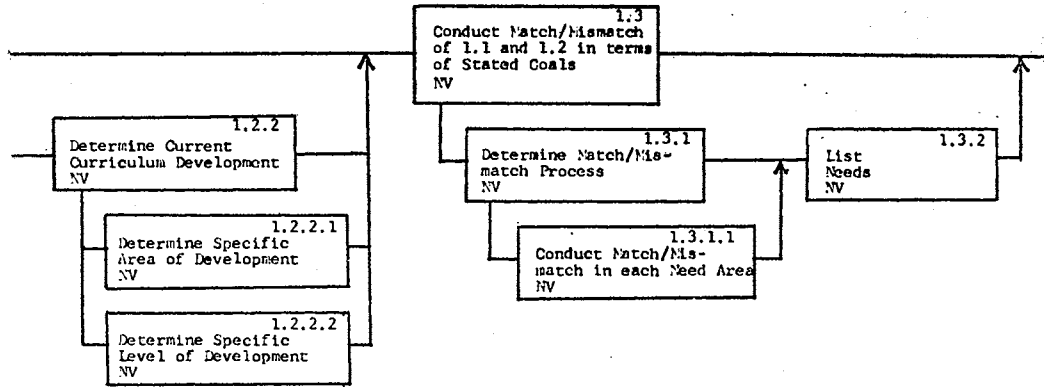

Figure 9 (Continued)



development. This activity will clearly differentiate those needs which are not being met, resulting in what is termed a mismatch. In most elementary schools this will produce a substantial list of needs.

The next action is illustrated by Figure 10. It is a relatively simple process but the NV constant will exert a tremendous amount of influence upon the selection of the priority needs. The need for involvement of all persons within the system in priority need selection cannot be overemphasized.

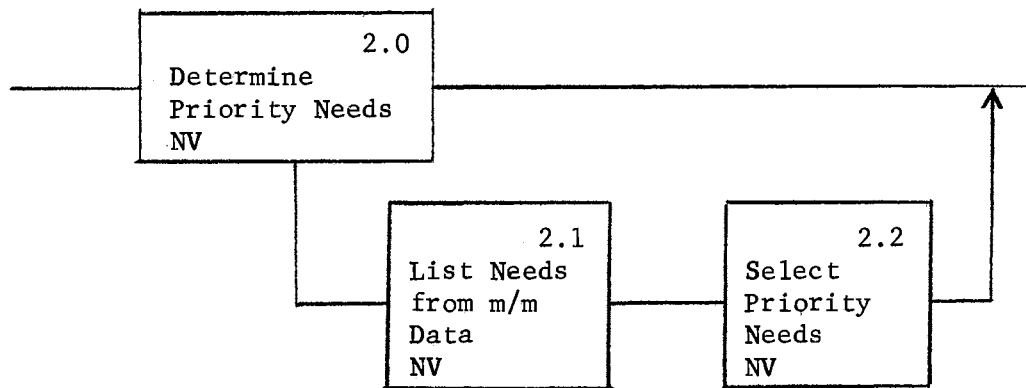

Figure 10. Need Selection

The next top level function is to determine solution strategies for meeting the priority needs. The strategies may vary from programs devised for individual learning experiences to group experiences, to total school experiences. The program will be defined as the series of interaction taking place while a student is involved in the learning process. As shown in Figure 11 sources for data which are to be used

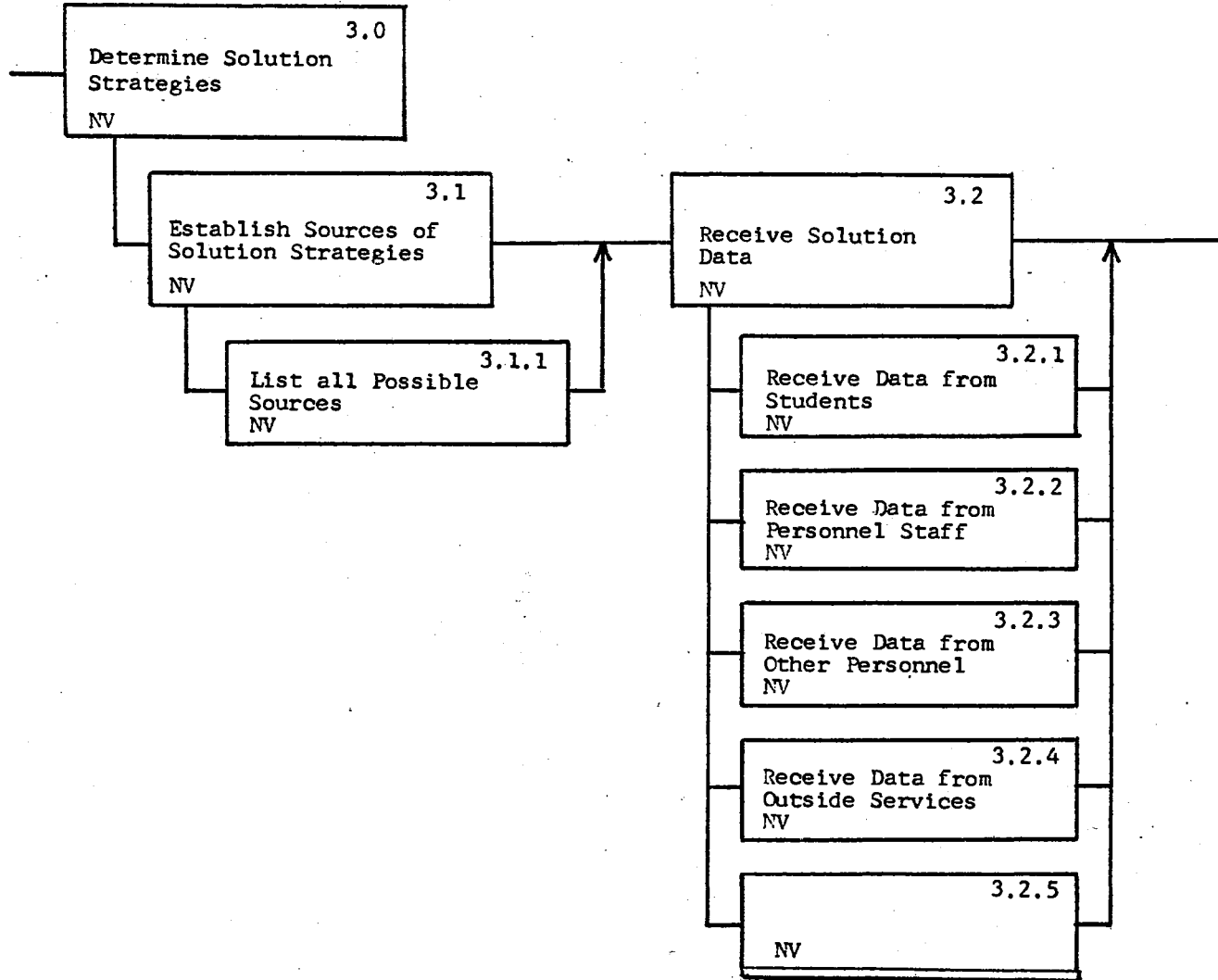

Figure 11. Solution Sources

in synthesizing the solution strategies are many and varied. It is assumed that the input data from each source will have been derived from that source's knowledge base in interplay with its NV constant. In subfunction 3.3 (Figure 12) the input data are put together to form the program with the guiding factor being the previously stated goals. Although there has been a constant check back to constraints throughout the system through the iteration process, at this point a subfunction for determining constraints is especially useful. Also at this point it is grossly determined which programs can be developed to a reasonable degree of effectiveness. At this time also there may be a delineation of which programs are to have priority, based upon the constraints. For example, it might be that a school decided upon six priority needs that were to be met by the curricular-instructional program. The constraints may dictate that only four solution programs could be implemented under present circumstances. Obviously priority decisions would have to be made at this time.

The determination of goals and objectives for the specific program as expressed by subfunction 3.3.1 (Figure 12) is a critical process. Naturally the NV constant is truly put to the test in this operation. The necessity to refer back to the mission statement at this system stage is crucial. The chief factor here both in human interactions and system interaction is honesty. In the development of the solution program there can be no variance from the previously stated goals. The system design at this stage forces behavior and action into alignment with these goals.

The system design establishes the need for the accomplishment of a task analysis and a methods-means analysis in the subfunctions under

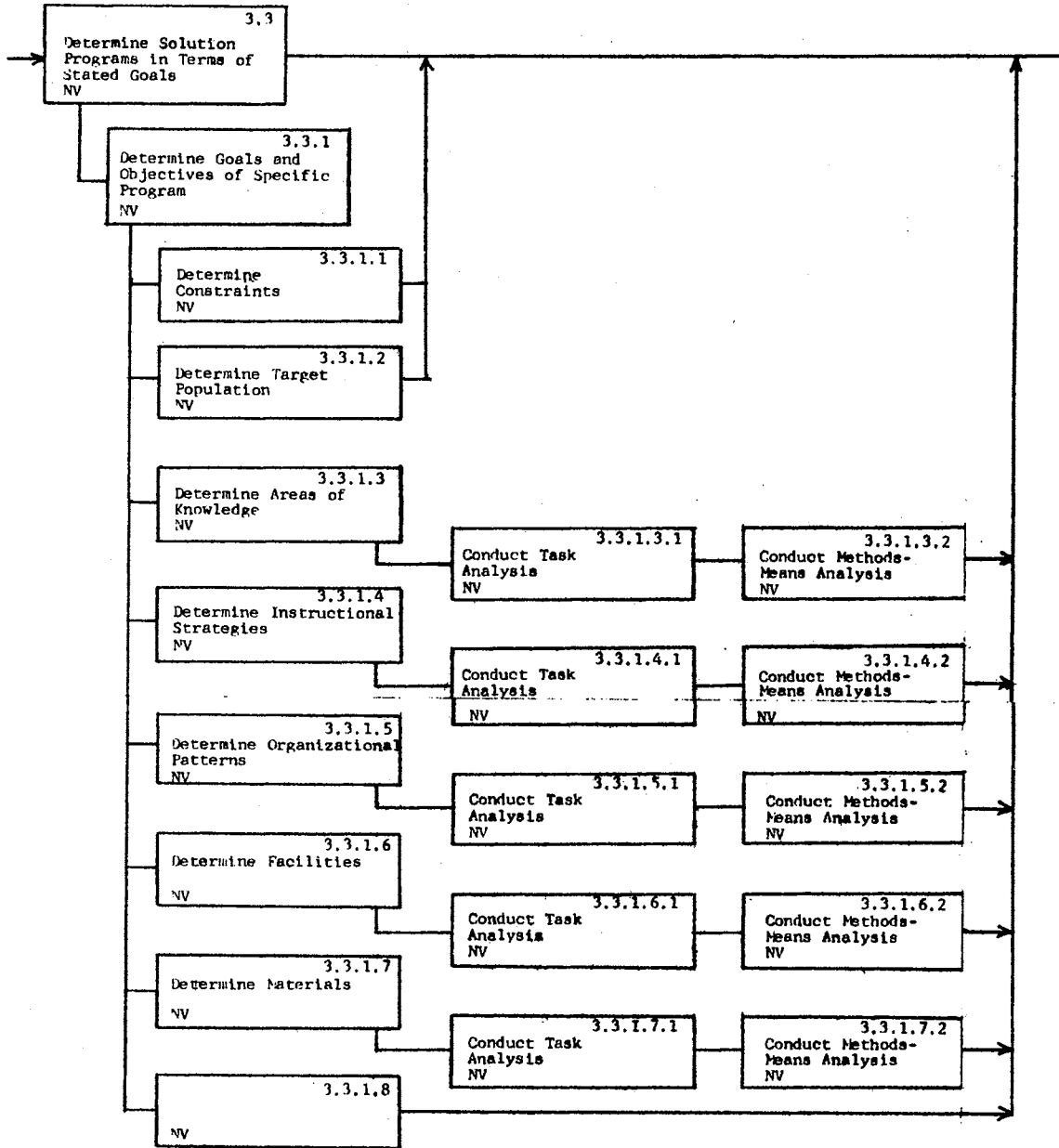

Figure 12. Program Determination

3.3.1. These analyses are the determinants of what tasks are necessary in order to perform the function as well as how they may be performed. There is not a selection of one of the "hows" but merely a listing of them.

Subfunction 3.4 deals with the extremely complex human element in the system. Human characteristics are the prime determinant of all the interpersonal relationships occurring during the implementation phase of the system. Figure 13 illustrates the break out of subfunction 3.4. An analysis is made to determine what type of persons are needed to implement the program. After the match/mismatch subfunction (3.4.3) is carried out, a determination can then be made as to staff needs. Priority needs are established and then a staff can be selected to implement the programs. Figure 14 shows subfunctions which take place during this phase.

Top level function 4.0 is actually putting the solution strategy into operation. Figure 15 contains the design for this phase of the system's operation and is essentially synthesis operation. Functions and tasks are allocated to personnel within the system. The total number of "hows" are scrutinized and a specific method is determined. Further analysis as to the means of operation is conducted. The iteration process is important here since a particular "how" may not accomplish the task and evaluative feedback would provide for alternative "hows" to be implemented. The provision of physical facilities and materials follows the methods-means analysis. The selection of facilities and materials come after all the analytical procedures. This means that facilities and materials are not the precursors to that which is deemed desirable for students involved in the learning process.

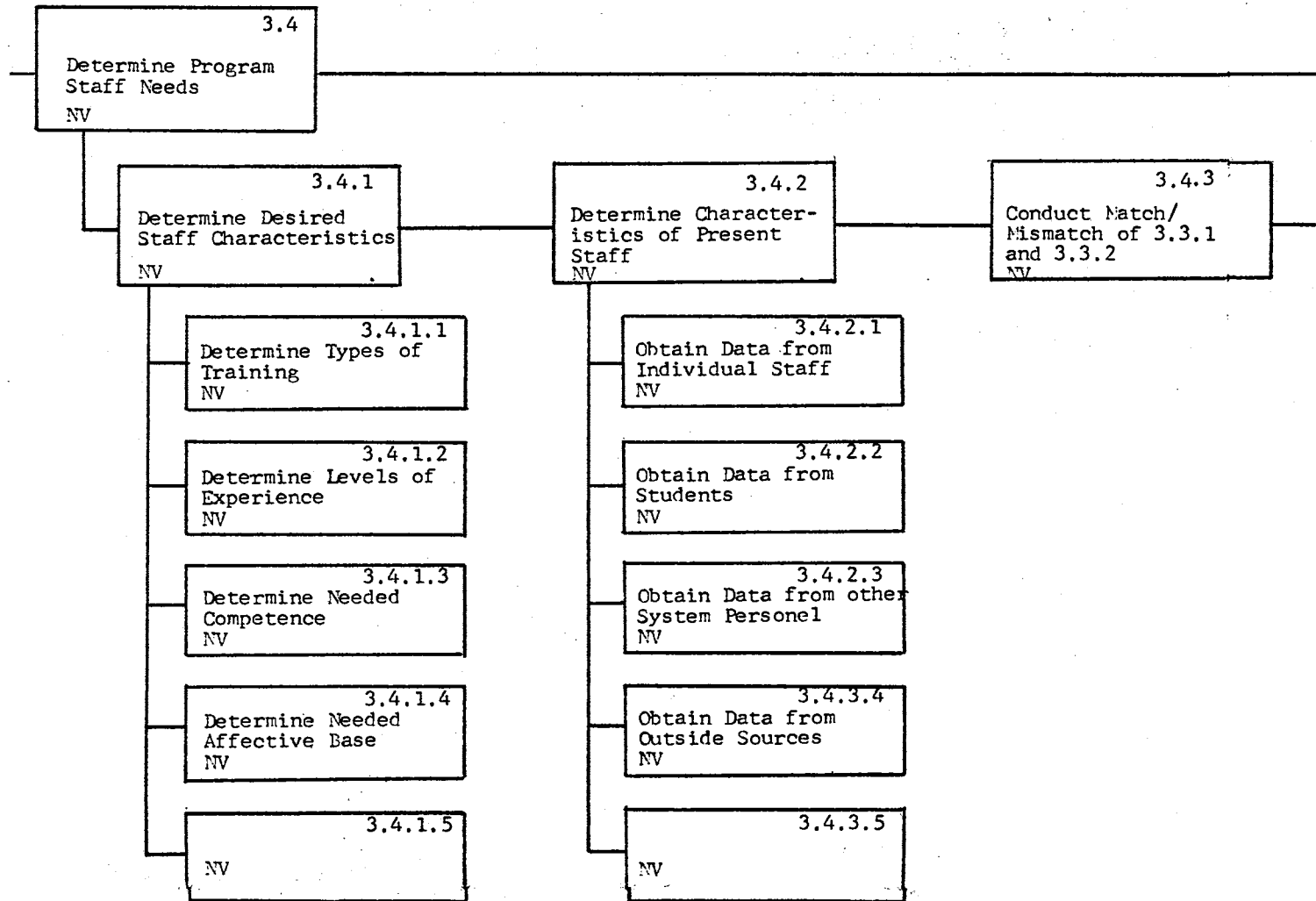

Figure 13. Staff Needs Determination

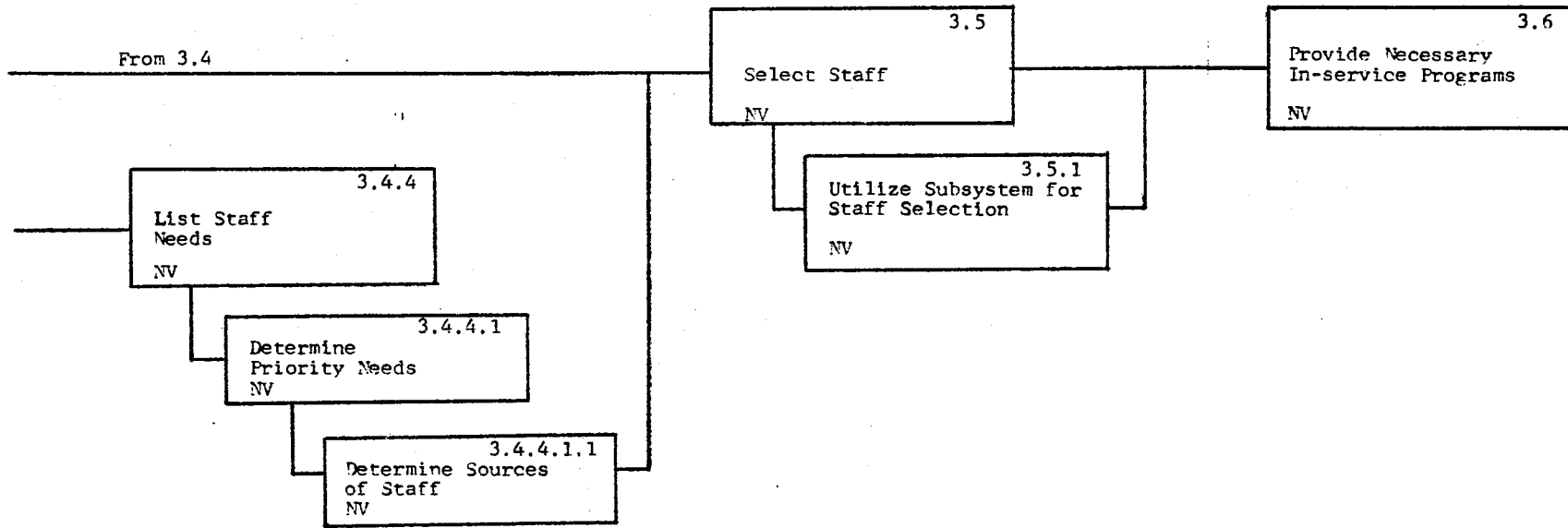

Figure 14. Staffing Processes

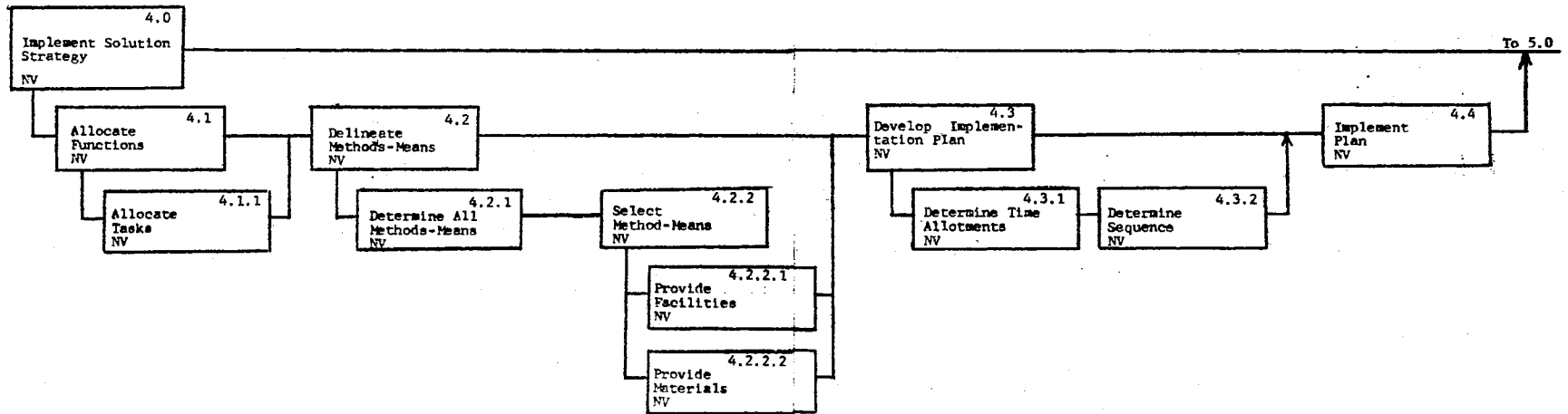

Figure 15. Implementation



Under function 4.3 a plan is designed for the total implementation process paying particular attention to time allotment and sequencing. For example, there is a definite time span between the beginning of the formal school operation and its end and this is taken into consideration in planning. P.E.R.T. (Program Evaluation and Review Techniques) and C.P.M. (Critical Path Method) techniques would be highly desirable tools to be used in developing and implementing the plan.

The last top level function to be performed is evaluation. As has been previously stated, the system, by means of the iteration process, has undergone constant evaluation throughout the analysis and synthesis phases. This function however provides a culminating effort focusing primarily upon learner performances. These performances are evaluated back to intermediate goals and eventually to the mission statement. This evaluation is also an evaluation of the entire system's performance.

The determination of the performance requirements was done during the mission analysis. Almost all performances will lie in the affective, cognitive, and psychomotor areas. The NV constant will greatly affect the desired performances and the setting of performance levels. It would seem desirable to measure as accurately as possible all of those performances which are quantifiable. At the same time full recognition must be given to those performances which are nonquantifiable. Sensitivities, attitudes, and feelings which are expressed in performances by the learner lend themselves, in many cases, to qualitative evaluation procedures. Many times it is a value judgement which prevails. These judgements must be made with full recognition of the N.V. constant and in such a manner as to provide alignment with all

intermediate goals and the mission statement.

Figure 16 depicts the break out of the evaluation functions. Through subfunction 5.1.1.3 provision is made for the evaluation by external persons. Although the environment itself is constantly evaluating the system and student performance this subfunction provides for specific evaluative processes.

With the completion of the evaluation function an assessment can be made of the degree to which the mission is being accomplished. The focus has been upon the learner. The system, being a dynamic entity, can accommodate change. Surely student performances, as measured back against the mission statement, will necessitate system revisions. The students' performance at or above the designated level in a certain area would definitely influence the needs and thereby directly influence the priority needs. Program changes would result from this change in priorities. Unacceptable performance levels would also call for revisions in instructional strategies and a complete re-analysis of methods-means.

If the system is open and sensitive probably the most fundamentally critical change which would affect the entire system is a change in value. Since by design the NV constant permeates every operation and interaction any change in the constant itself would be reflected throughout the system.

Figure 17 provides a view of the entire system. It does not illustrate all subfunctions and task levels but does provide a composite of every major portion of the system discussed in this text.

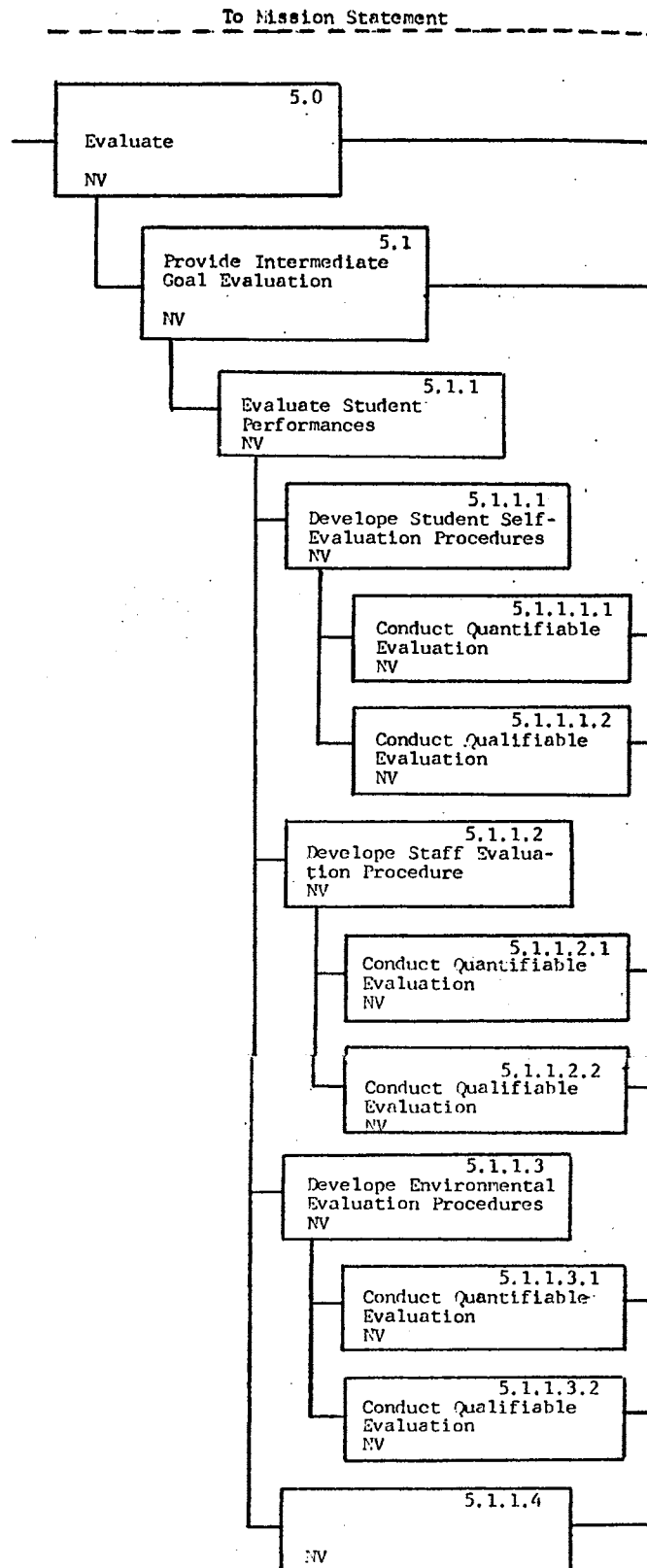

Figure 16. Evaluation Processes

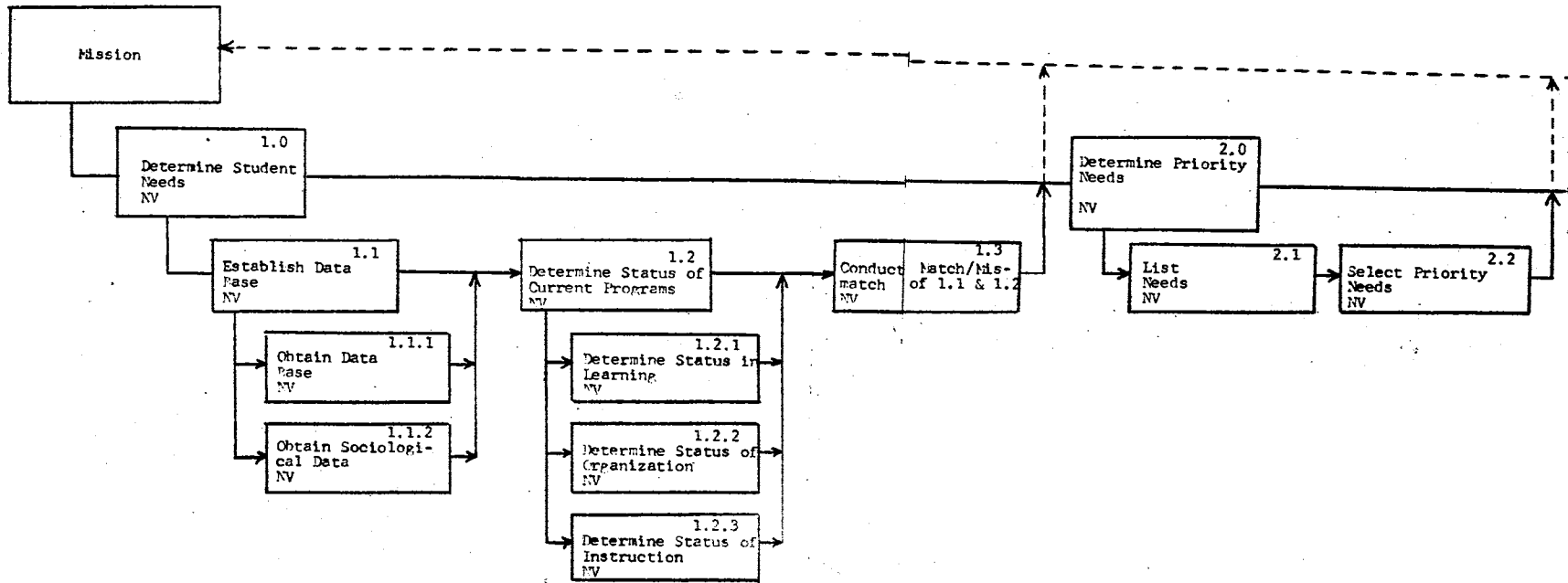

Figure 17. A Theoretical System

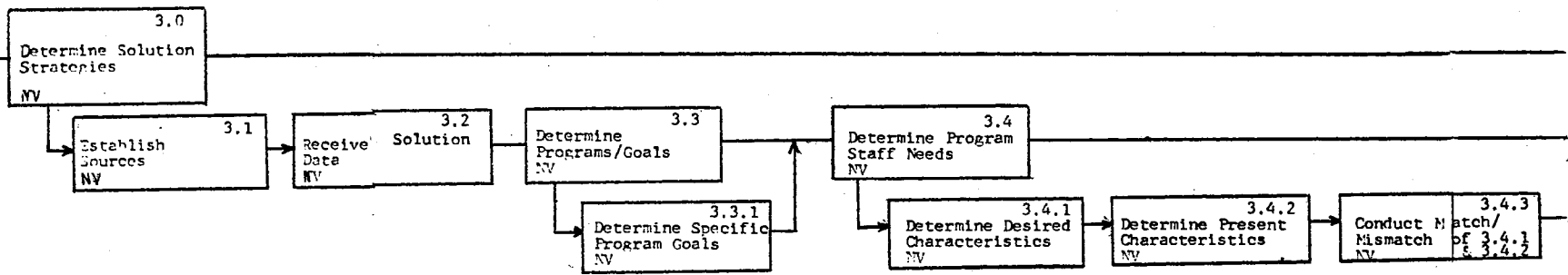

Figure 17 (Continued)

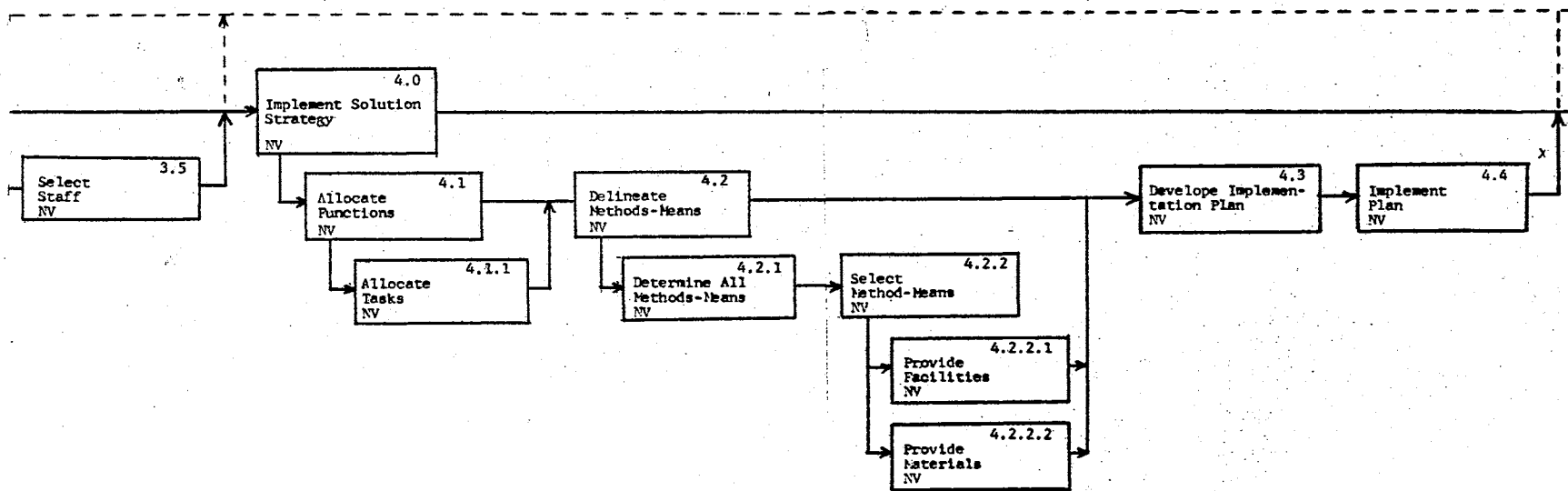

Figure 17 (Continued)

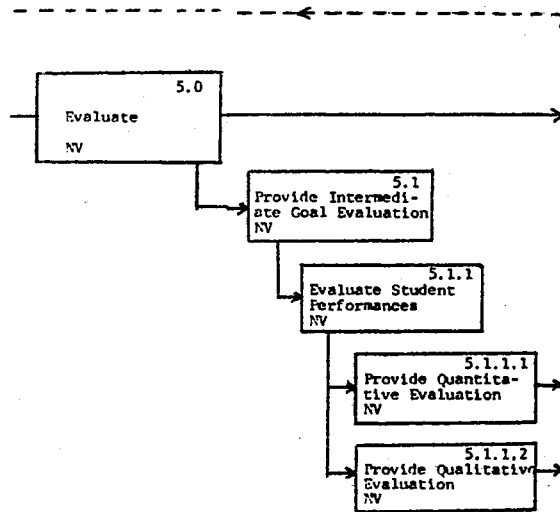

Figure 17 (Continued)

## CHAPTER VI

### THEORY INTO PRACTICE

A clarification of the system's operation would probably come about if a portion of a mission statement were taken through the system. This would be an entirely hypothetical situation and under no circumstance should it be viewed as prescriptive in nature.

A major assumption of the theory has been the involvement of all persons immediately affected by the system in the curriculum developmental process. In mission statement development this is especially crucial. There could be many approaches used to arrive at a mission statement but those involving open interactions with agreements and disagreements would probably be best in the long run. Brainstorming and free-wheeling, independent thought-producing sessions seem to be especially effective for getting as complete a statement as possible. Whatever techniques are used, the aim is to obtain a written statement which will give direction to the school program. Although the parameters of this study have deliberately excluded suprasystem and subsystem development it seems to be of import to note that leadership characteristics are extremely vital in allowing participative action to develop the mission. The NV constant is again emphasized as having tremendous influence upon the final form of the mission statement.

The mission statement is developed within the constraints that are peculiar to each school situation. Generally speaking, the most common



constraints are: the amount of money allocated for the operation of the school, the length of the school year (time), state and local policy regulations, and laws pertaining to schools. It is the recognition of the constraints that is of primary importance although alleviation of some of them could most certainly be made a part of the system's operation.

In the hypothetical situation suppose the mission statement contained the phrase "develop thinking processes." This would lead to an analysis of exactly what "develop thinking processes" means. There would need to be a clear definition. The definition could include all the types of thinking that are presently known to exist. A partial list might be creative thinking, convergent thinking, divergent thinking, and productive thinking. The persons within the system might settle on the definition to be those levels of thinking as categorized by Bloom's taxonomy (1956). In the taxonomy, Bloom, et al. have listed the levels of the cognitive process from lowest to highest as the following: knowledge, comprehension, application, analysis, synthesis, and evaluation. If these levels become the definition attached to the phrase in the mission there would then have to be a statement of desired levels of performance. A statement could possibly be like the following, "At the end of seven years all the children in X school will be able to demonstrate their performance at each level of thinking to the Y degree."

If we take the phrase "develop thinking processes" to the system we would enter at function 1.0 (Figure 9, page 72) which is determination of needs. For this "walk through" it must be realized that we cannot involve every subfunction on our way through. In this case we

would proceed directly to establish a data base (subfunction 1.1), then to obtain personal data (subfunction 1.1.1), and then to obtain cognitive data, subfunction 1.1.1.3 (see Figure 18). This does not mean, for example, that analysis of subfunction 1.1.1.1, which is obtaining physiological data, is not of significance as we proceed through the system. In fact, physiological deficiencies may impair cognitive function to such a degree that we cannot get an accurate need assessment in the other categories. Therefore in our "walk through" we will only be making reference to the most pertinent subfunctions with a full realization that all other functions and subfunctions are interrelated.

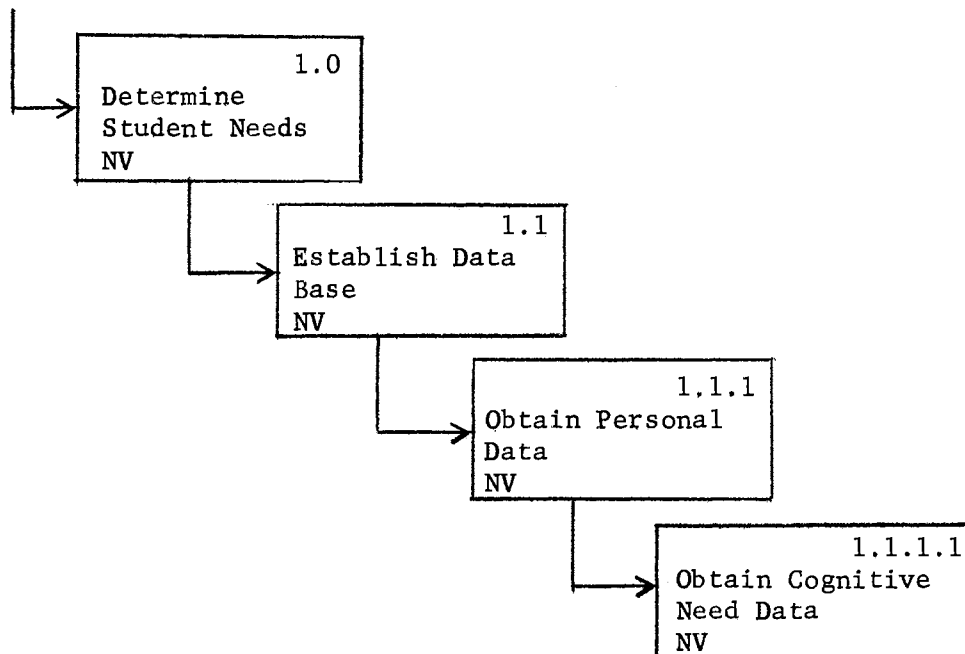

Figure 18. Need Determination

Subfunction 1.1.1.1 could be performed by a school wide diagnosis of the levels of thinking of the students. Standardized tests, teacher-made tests, subjective observations, and oral questioning could provide data on the levels of thinking. Oral questioning then could become a subfunction of obtaining cognitive need data.

At this point a task analysis and a methods means analysis could be conducted for the subfunction of questioning students orally (subfunction 1.1.1.1.1 in Figure 19). Questioning the students individually or in a group are tasks and there would be an alternative posed here.

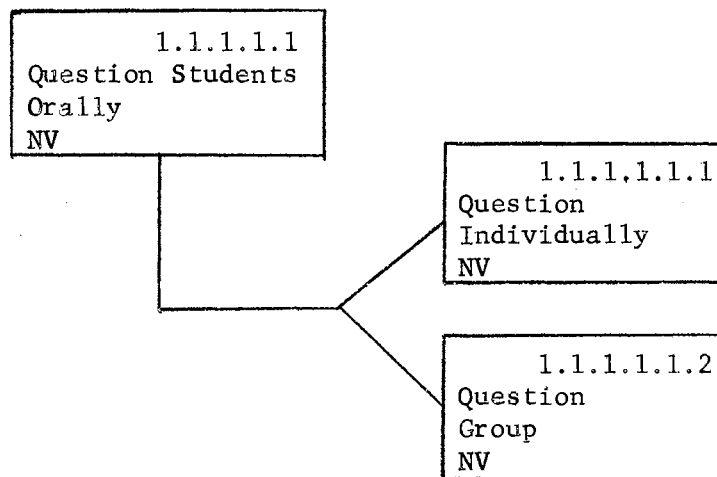

Figure 19. Task Analysis

In determining how you question students either individually or in groups you would be determining the methods. Two methods might be: (a) on a one to one basis alone, or (b) on a one to one basis within a

small group. The means that could be used could be: (a) using the teacher in verbally posing the question, or (b) using a tape recorder to pose the question. Figure 20 illustrates the methods-means analysis. In this hypothetical situation only two methods and means are illustrated, however, in actual practice there would probably be several methods and several means determined.

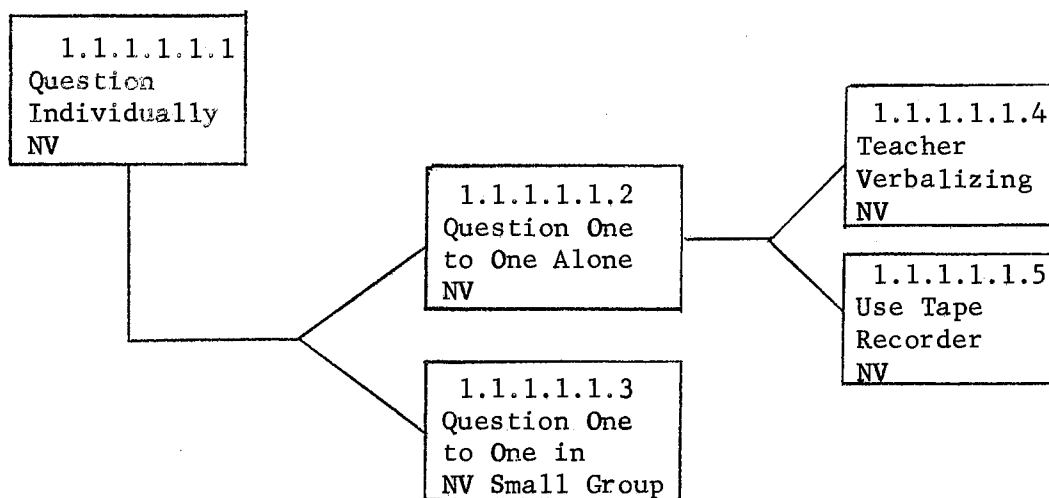

Figure 20. Methods-Means Analysis

The above example has carried the process vertically downward to the ultimate methods-means analysis and as the phrase "develop thinking process" is taken through the system it is assumed that every function and subfunction is to be carried this far. Limitations in this writing forego taking these steps all the way to their conclusion in every case.

From the need determination procedures in the area of cognitive needs those general deficiencies in thinking processes can be determined. If then, an assessment is made of the current curricular-instructional program there can be a matchup of the cognitive needs with the experiences which are being provided students. This matching should delineate those needs and areas of curriculum in which students are not performing according to the definition and criteria established for "develop thinking processes." These delineated needs would have to be considered with all the other needs that are established by the determination of needs function (1.0). Looking at the total school operation and at the entire population, priorities then would be established (function 2.0).

In our hypothetical situation we might conclude that from the cognitive need assessment that most of the students were reaching acceptable levels of performance in the levels of knowledge, comprehension, and application but were not reaching acceptable levels in analysis, synthesis, and evaluation. If this need is determined to be a priority need within the school we would then proceed to the top level function 3.0 which is the development of solution strategies. Figure 21 illustrates the partial breakdown of determining solution strategies. Referral back to Figures 11, 12, 13, and 14 (pages 75-80) would give the reader a more global picture of the total operation.

If the cognitive needs for "developing thinking processes" lie in the analysis, synthesis, and evaluative thinking levels then the question "What can be done to solve these needs?" is asked. Utilizing all possible sources within the school and its environs, data are received that would propose solutions to the needs. From all of this information

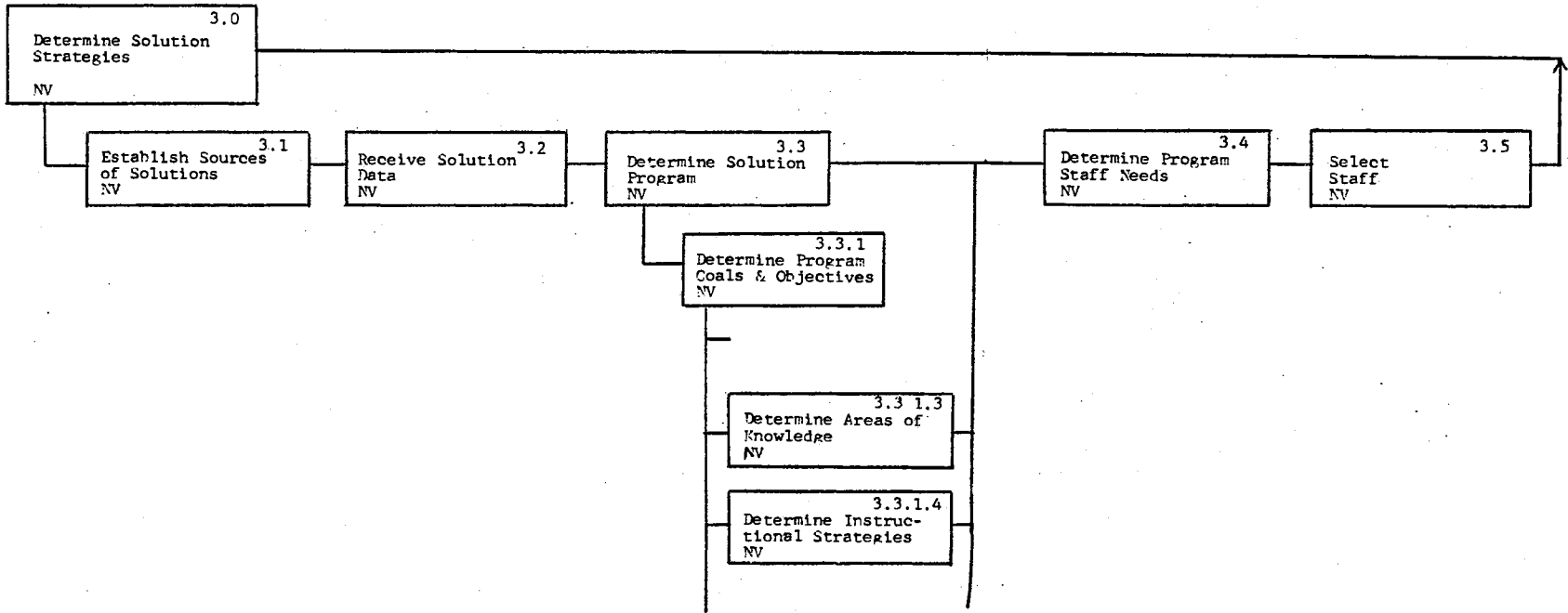

Figure 21. Solution Strategy Determination

a program is formulated to solve the needs. Subfunction 3.3.1 is a critical operation as it involves defining the goals for the particular program. In the hypothetical situation a goal might be: Provide students with experiences in analyzing, synthesizing, and evaluating. This goal actually becomes an intermediate goal between the phrase "develop thinking skills" in the mission statement and the objectives that are to be realized by student performances. As an intermediate goal it is required to be in alignment with the mission statement. In this writing only two subfunctions under 3.3.1 are broken out further and these are: determine areas of knowledge (subfunction 3.3.1.3) and determine instructional strategies (subfunction 3.3.1.4). In determining the areas of knowledge we are merely utilizing the knowledge area as a vehicle to attain the aforementioned program goals. Admittedly, in the selection of these areas value judgements are made concerning what is worth knowing for the elementary student. At this point, however, we are not primarily concerned with a specific area of knowledge and the selection could be mathematics, or social science, or any other area worth knowing. An analysis of the area of knowledge is broken out in Figure 22.

In determining the instructional strategies (Figure 23) it is necessary to be explicitly cognizant of the established intermediate goals. In systems theory both the mission statement and the intermediate goals are process-type goals. The ultimate experiences provided the learner are focused upon these goals and therefore the instructional strategies are of utmost importance. In this situation these instructional strategies are aimed at eliciting analytic, synthetic, and evaluative thinking operations. As in every methods-means analysis

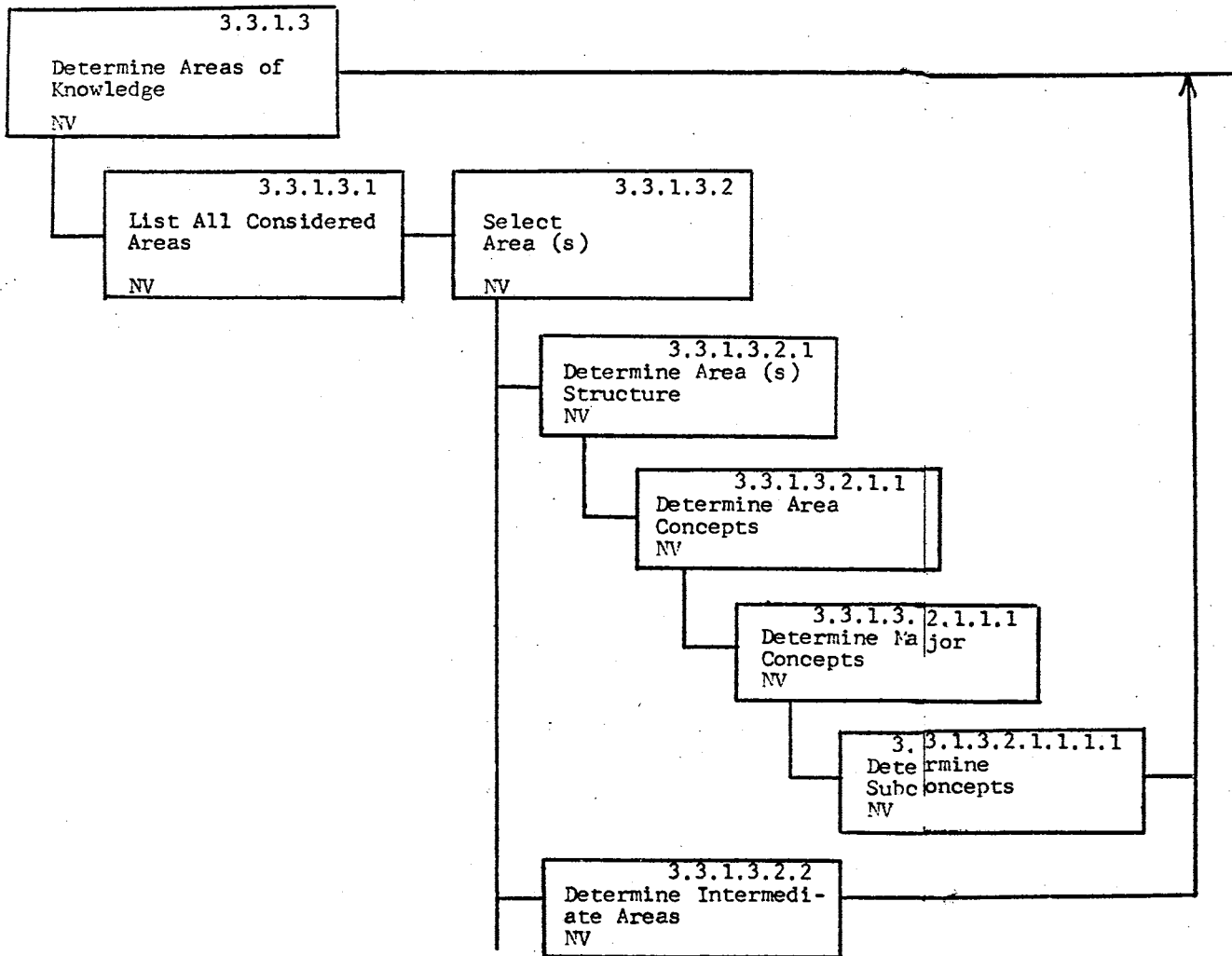

Figure 22. Knowledge Determination



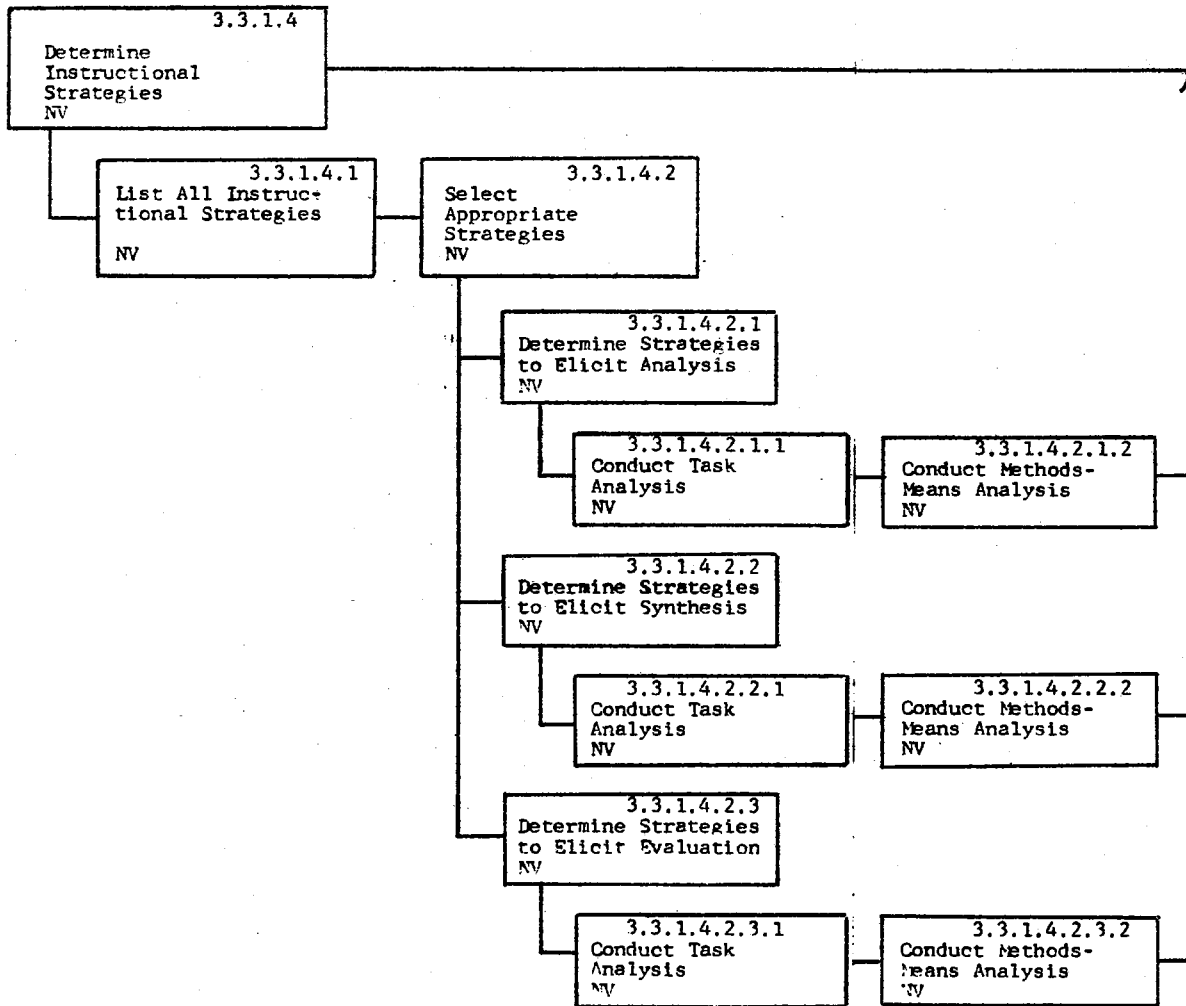

Figure 23. Instructional Strategy Selection

there should be a listing of all of the methods and means that are known to those persons conducting the analysis. There is no attempt to select a particular method or means at this time.

From the determination of the solution program (3.3 Figure 21) the next step is to analyze what is needed in terms of staff to implement the program (subfunction 3.4). Referring to Figure 24 and also to Figure 13 (page 79) the necessary steps are outlined. Essentially what is being done is determining the desired characteristics of staff members which would perform best in allowing students to analyze, synthesize, and evaluate and then comparing these characteristics to those of the present staff members. From this match/mismatch procedure discrepancies should be readily apparent. Decisions are then made for staff selection and for any necessary in-service programs to develop those characteristics, to the greatest degree possible, that are necessary for program implementation. It might be noted here that the system could establish varying staffing patterns which would be entirely unlike those presently existing in elementary schools,

The next procedural step would be to implement the program to accomplish the selected intermediate goals and mission statement (Function 4.0). Figures 15 and 25 (pages 81 and 101) illustrate the procedures to be taken. Functions or jobs to be performed are allocated to personnel along with the accompanying tasks. Allocations could be made according to staff strengths as well as interests. The delineation of the methods is left entirely up to the staff. The individuality of humans is of prime concern at this point. The expression of this individuality is entirely an open-ended process. The NV constant will exert great pressure upon the selection of methods. Since the NV

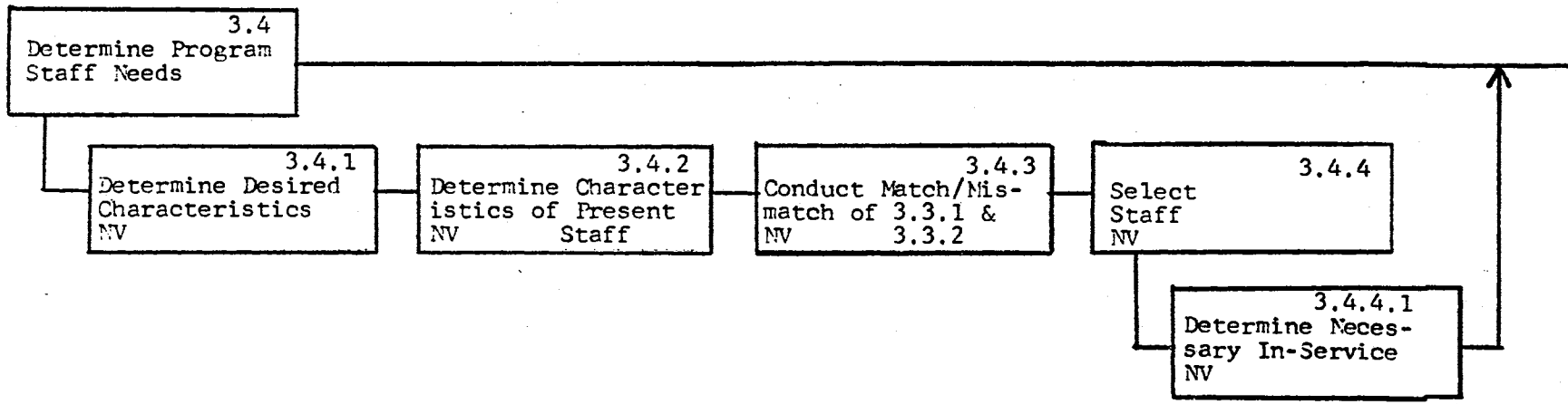

Figure 24. Staff Selection

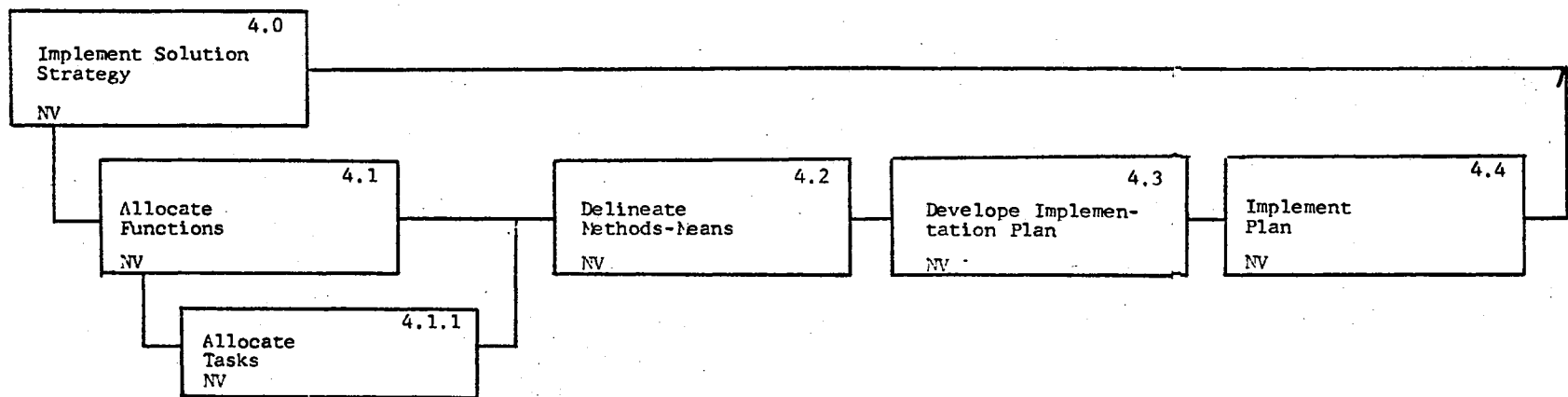

Figure 25. Implementation Procedure

constant has been present throughout the system and the values and beliefs about the nature of things will have been open to debate and interaction, it would be assumed that the NV constant at this level would reflect the outcomes of that debate and interaction. Thus the alignment of the NV constant from the mission to the interaction process with teacher and student is assured.

From the delineation of methods-means (subfunction 4.2) a further breakout could be made as in Figure 26. If an area of knowledge (such as social studies) had been selected previously in the system then it would seem appropriate to investigate the structure of this area. If social studies does include sociology then the question could be posed as to what are the major concepts of sociology. Many sociologists agree that the concept of cultural differences is a major concept. If, in this hypothetical situation, the concept of cultural differences was selected, it then could be used as a tool to involve students in the higher level thinking processes.

Figure 26 does show the selection of a method for each of the processes of analysis, synthesis, and evaluation. The open boxes in the figure indicate that there are alternative methods that could be taken to allow students to engage in these thinking processes. Although the means are not specifically determined, inspection of the method suggests many possible means which could be selected.

The development of the implementation plan (subfunction 4.3) is merely the designation of what will be implemented, when it will be implemented, and where it will be implemented. Naturally it would include the major and minor activities undertaken to allow students to analyze, synthesize, and evaluate.

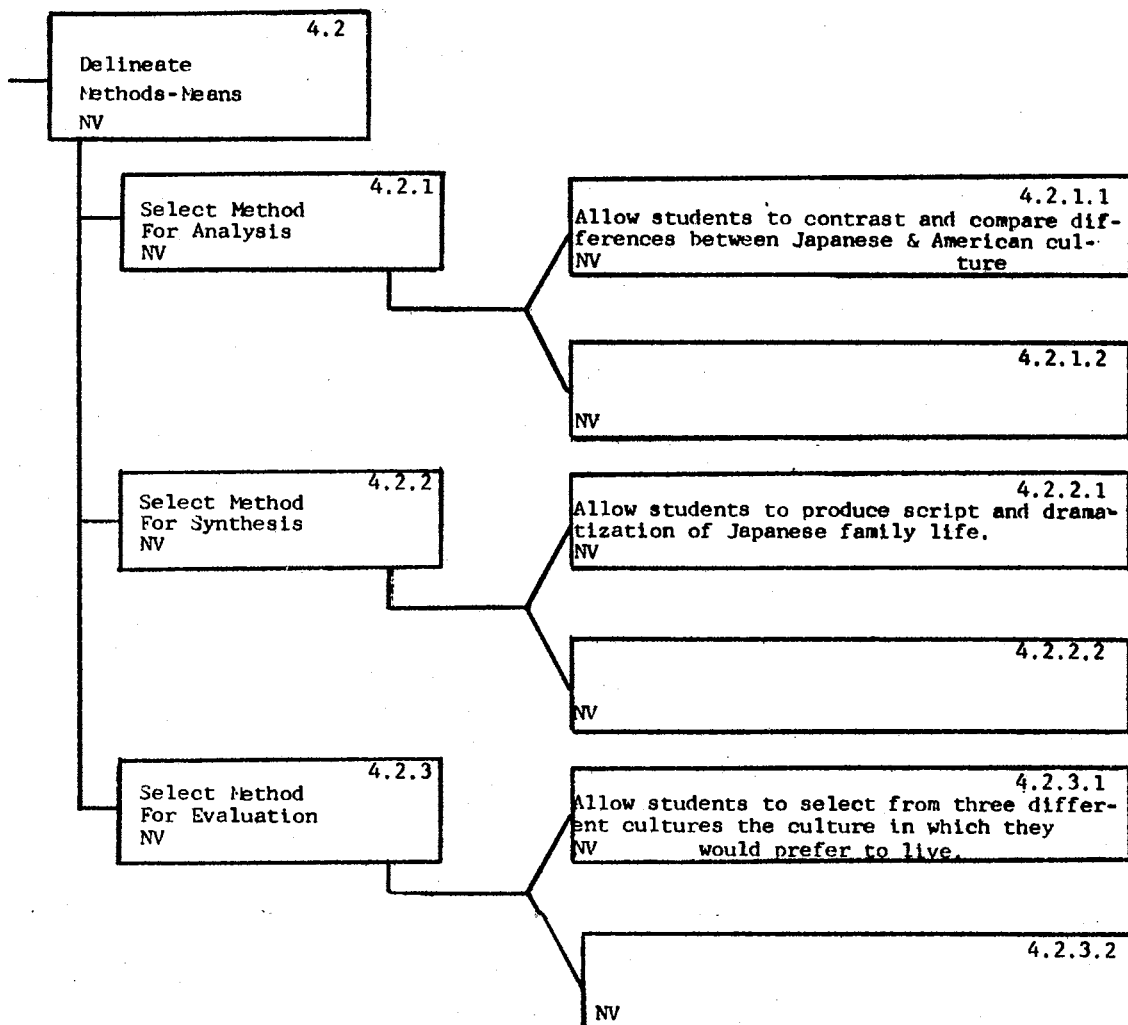

Figure 26. Methods Analysis

The following basic questions are to be answered in the evaluation process (Function 5.0): Has the program involved students in the stated thinking processes? Are the students able to carry out the thinking processes? To what extent are they able to analyze, synthesize, and evaluate?

From Figure 16 (page 84) the evaluation process includes both quantifiable and qualifiable evaluation procedures. It is assumed that there are certain student performances in the process of analyzing, synthesizing, and evaluating that can be measured. If, on the other hand, a student is engaged in a synthesizing operation that results in the production of a plan for solving a problem the evaluation of that plan may purely be of a subjective nature. The production of the designated plan might be quantifiable to the extent that the student either produced one, or did not produce one, but the level of performance in the operation may be expressed in purely subjective terms.

The assumption of personal involvement in the system's interactions by those persons affected by the system has been consistent throughout the design. Therefore student involvement is assumed. Student involvement in mission and goal development would allow for student self-evaluation to be achieved rather easily. Staff evaluation would be centered in the areas of student evaluation and staff self-evaluation. Student evaluation of both individual and group nature would provide feedback to the entire system operation.

Since student performances are the main output of the system into the environment, those persons in the environment, particularly parents, would be involved in outside evaluation. Their feedback into the system would be important input. One advantage of the mission statement

is the clarification of the mission's intent to the environmental forces. Evaluation by outside forces would have to be based upon the mission statement. Since the system is open it would be sensitive to this outside evaluation. In the hypothetical situation that has been proposed the entire evaluation function would be focused upon the phrase "develop thinking processes." In actuality there would be as many additional foci as there were additional priority needs and goals identified in the system's operation.

The phrase "develop thinking processes" has been taken through the major operations of the system. While the phrase was not taken through many lower level functions it is assumed that a coherent picture of the path has been produced. While this example concentrated upon what is commonly termed the cognitive domain it is also possible to take a particular aspect of the affective or psychomotor domains through the system. For example, the phrase "allow students to develop a positive self-concept," could be taken through. With the prior major assumptions made by this writer any goal desired by those persons affected by the system could be analyzed and the process for achievement synthesized. Without a doubt, developing a positive self concept would be harder to measure (if it could be measured) than many cognitive or psychomotor aspects. If an affective-based goal is stated however, the design of the system will not allow misalignment or gross deviation in the interactions within the system. While a properly designed system is sensitive to change that change would come about in "full view." In other words the system would be dysfunctional if what was being done was not what was said was going to be done.



A major premise is that the whole procedure is open to careful analysis of the "whats" and "hows" that are necessary to achieve the mission. A second major premise is that there are no preconceived notions in any of the interaction processes. For example, there should be no preconceived notions with respect to organizational patterns, group, staff assignment, location of learning activities, etc. The type and quality of such an analysis is mainly dependent upon the persons affected by the system.

This paper has been a statement of relationships, a statement which has not been finally accepted. The move from theory into practice has been attempted by carrying the theoretical considerations through an operational system. The model has been the vehicle for carrying the statement of relationships through the operations. It is hoped that the theory and model have accommodated both the rational and irrational aspects of man.

## BIBLIOGRAPHY

- Achinstein, P. "Models, Analogies and Theories." Philosophical Science, 31 (1964), 328-334.
- Ackoff, R. L., S. K. Gupta, and J. S. Minas. Scientific Method Optimizing Applied Research Decisions. New York: John Wiley and Sons, 1962.
- Alberty, Elsie J. "Toward a Framework for Curriculum Development." Theory Into Practice, VI, No. 4 (October, 1967), 204-207.
- Allport, Gordon W. The Nature of Prejudice. Boston: Beacon Press, Inc., 1954.
- Anderson, R. D. "Children's Ability To Formulate Mental Models To Explain Their Observations of Natural Phenomena." (unpublished Doctoral dissertation, University of Wisconsin, 1964).
- Ausubel, David P. "A Cognitive-Structure Theory of School Learning." Instruction: Some Contemporary Viewpoints. Ed. Laurence Siegel. San Francisco: Chandler Publishing Co., 1967, pp. 207-260.
- Ausubel, David P. and Richard C. Anderson, eds. Readings in the Psychology of Cognition. New York: Holt, Rinehart, and Winston, 1966, p. 3.
- Baldwin, A. L., J. Kalhorn, and F. Breese. "Patterns of Parent Behavior." Psychological Monographs, No. 58, 1945.
- Baller, Warren R., and Don C. Charles. The Psychology of Human Growth and Development. New York: Holt, Rinehart and Winston, Inc., 1968.
- Belanger, M. "Methodology of Educational Research in Science and Mathematics." Review of Educational Research, XXXIV, No. 3 (June, 1964), 234-247.
- Bigge, Morris L. Learning Theories for Teachers. New York: Harper and Row, 1964.
- Blackham, Garth J. The Deviant Child in the Classroom. Belmont, California: Wadsworth Publishing Co., 1967.
- Blakney, Raymond B. An Immanuel Kant Reader. New York: Harper and Bros., 1960.

- Bloom, Benjamin S., ed. Taxonomy of Educational Objectives. New York: David McKay Company, 1956.
- Bobbitt, Franklin. The Curriculum. Boston: Houghton Mifflin, 1918.
- Bridges, Katherine M. B. "A Genetic Theory of the Emotions." Journal of Genetic Psychology, No. 37 (1930), 514-527.
- Broudy, Harry S. "To Regain Educational Leadership." Studies in Philosophy and Education, II (Spring, 1962), 132-158.
- Broudy, Harry S., O. Smith, and J. R. Burnett. Democracy and Excellence in American Education: A Study in Curriculum Theory. Chicago: Rand McNally and Company, 1964.
- Bruner, Jerome S. The Process of Education. New York: Alfred A. Knopf Inc., 1960.
- Bruner, Jerome S. On Knowing-Essays for the Left Hand. Cambridge, Massachusetts: Belknap Press, 1964.
- Butler, R. A. "Curiosity in Making." Scientific American, 190 (1954), 87-93.
- Caswell, H. L. "Emergence of the Curriculum as a Field of Professional Work and Study." Precedents and Promises in the Curriculum Field. New York: Teachers College Press, 1966.
- Cattell, R. B. Personality and Motivation: Structure and Measurement. New York: Harcourt, Brace and World, 1957.
- Chapanis, A. "Man, Machines and Models." American Psychology, 16 (1961), 113-121.
- Chapman, Ivan. a. Lecture, Oklahoma State University, September 13, 1970.
- Chapman, Ivan. b. Lecture, Oklahoma State University, December 11, 1970.
- Charters, W. W. Curriculum Construction. New York: Macmillan, 1923.
- Coleman, James C. Personality Dynamics and Effective Behavior. Glenview, Illinois: Scott, Foresman and Company, 1960.
- Combs, Arthur W. "A Perceptual View of the Adequate Personality." Perceiving, Behaving, Becoming. Association for Supervision and Curriculum Development, N. E. A., 1962.
- Cooley, Charles H. Social Organization. Glencoe, Illinois: The Free Press of Glencoe, 1956.
- Gremin, Lawrence. The Genius of American Education. Pittsburg: University of Pittsburg Press, 1965.

- Dahlke, Otto H. Value in Culture and the Classroom. New York: Harper and Bros., 1968.
- Eisner, Elliot W. "Curriculum Theory and the Concept of Educational Milieu." The High School Journal, LI (1967-68), 130-136.
- Erickson, Erik H. Childhood and Society. New York: W. W. Norton, 1950, pp. 219-231.
- Etzioni, Amitai. Modern Organizations. Englewood Cliffs, N. J.: Prentice Hall, 1964.
- Festinger, Leon. A Theory of Cognitive Dissonance. Stanford, California: Stanford University Press, 1962.
- Flothow, Rudolph C. "Systems Analysis and School Functions." Journal of Secondary Education, Vol. 42, No. 6 (October, 1967), 245-250.
- Foshay, Arthur W. "Shaping Curriculum: The Decade Ahead." Influences in Curriculum Change. Association for Supervision and Curriculum Development, N. E. A., 1968.
- Freud, Sigmund. Psychopathology of Everyday Life, 2nd ed. London: Ernest Benn Ltd., 1954.
- Gagne, R. M. The Conditions of Learning. New York: Holt, Rinehart and Winston, 1965, p. 12.
- Gay, Peter. John Locke on Education. New York: Bureau of Publications, Columbia University, 1964.
- Goodlad, John I. "The Changing American School." National Society for the Study of Education, Sixty-Fifth Yearbook, Part II. Chicago: University of Chicago Press, 1966, pp. 180-203.
- Goodlad, John I. "The School Scene in Review." School Review, 66 (December, 1958), 391-401.
- Gordan, Ira J., ed. Theories of Instruction. Association of Supervision and Curriculum Development, N. E. A., 1968.
- Gow, J. Steele, Jr., Burkart Holzner, and William Pendelton. "Social, Political, and Economic Forces." The Changing American School, Society for the Study of Education, Sixty-Fifth Yearbook, Part II, 1966, pp. 135-157.
- Griffith, Daniel E. Administrative Theory. New York: Appleton-Century Crofts, Inc., 1959.
- Guilford, J. P. "Three Faces of the Intellect." American Psychologist, No. 14 (1959), 469-479.
- Guthrie, E. R. The Psychology of Learning. New York: Harper and Brothers, 1952.

- Harriman, L., ed. Dictionary of Psychology. New York: Philos Library, 1947.
- Hartley, Harry. "Limitations of Systems Analysis." Phi Delta Kappan, L, No. 9 (May, 1969), 515-519.
- Havighurst, Robert J. Development Tasks and Education. New York: Longmans, Green and Co., 1952.
- Havighurst, Robert J., and Bernice L. Neugarten. Society and Education. Boston: Allyn and Bacon, 1967, p. 8.
- Hefernan, Helen. "The Organization of the Elementary School and the Development of a Healthy Personality." California Journal of Elementary Education, IV, No. 3 (February, 1952), 17-37.
- Herrick, Virgil and Ralph Tyler, eds. Toward Improved Curriculum Theory. Chicago: The University of Chicago Press, 1950.
- Hertzler, J. O. American Social Institutions. Boston: Allyn and Bacon, Inc., 1961.
- Hilgard, Ernest R., and Gordon H. Bower. Theories of Learning. New York: Appleton-Century Crofts, 1966.
- Hilgard, E. R. Theories of Learning. New York: Appleton-Century Crofts, Inc., 1956.
- Hill, Winfred F. Learning: A Survey of Psychological Interpretations. San Francisco: Chandler Publishing Co., 1963.
- Homans, George C. The Human Group. New York: Harcourt, Brace and World, 1950.
- Hutten, E. H. The Language of Modern Physics. New York: The Macmillan Co., 1956.
- Insko, Chester A. Theories of Attitude Change. New York: Appleton-Century Crofts, 1967.
- Ittleston, W. H. "The Involuntary Bet." Vogue, March 15, 1967, pp. 26-27.
- Kaufman, Roger A. "A System Approach to Education: Derivation and Definition." Audio-Visual Communication Review, Vol. 16, No. 4 (Winter, 1968), 415-425.
- Kaufman, Roger A., R. E. Corrigan, B. O. Corrigan, and D. L. Goodwin. Steps and Tools of System Analysis as Applied to Education. Steps and Tools of the System Synthesis Process in Education. Mission Analysis in Education. Function Analysis in Education. Methods-Means Analysis in Education. (Pamphlets prepared for Operation PEP) San Mateo, California: San Mateo County Department of Education, 1967.

- Kelly, Earl C., and Marie I. Rasey. Education and the Nature of Man. New York: Harper and Bros., 1952.
- Kendall, M. G. "Model Building and Its Problems." Mathematical Model Building in Economics and Industry. London: Hanfer Publishing Co., 1968, pp. 1-17.
- Klohr, Paul R. "Seeking New Design Alternatives." A Curriculum for Children, Association for Supervision and Curriculum Development, N. E. A., 1969, pp. 87-97.
- Koffka, Kurt. Principles of Gestalt Psychology. New York: Harcourt, Brace and World, 1935.
- La Barre, W. The Human Animal. Chicago: University of Chicago Press, 1954.
- La Piere, Richard T. Social Change. New York: McGraw Hill Book Co., 1965.
- Lave, Ray E., Jr., and Donald Kyle. "The Application of Systems Analysis to Educational Planning." Comparative Educational Review, XII, No. 1 (February, 1968), 39-56.
- Macdonald, James B. "An Example of Disciplined Curriculum Thinking." Theory Into Practice, IV, No. 4 (1967), 169-173.
- MacIver, R. M. The Elements of Social Science. London: Methuen and Co., 1949.
- MacIver, R. M., and Charles H. Page. Society an Introductory Analysis. New York: Rinehart and Co., Inc., 1949.
- Mann, John S. "A Discipline of Curriculum Theory." The School Review, Vol. 76, No. 4 (December, 1968), 363-378.
- Maslow, A. H. Motivation and Personality. New York: Harper and Bros., 1954.
- Maslow, A. H. "Some Basic Propositions of a Growth and Self-Actualization Psychology." Perceiving, Behaving, Becoming. Association for Supervision and Curriculum Development, N. E. A., 1962, pp. 34-49.
- Mauch, James. "A Systems Analysis Approach to Education." Phi Delta Kappan, XLIII, No. 4 (January, 1962), 158-161.
- McLuhan, Marshall. "We Need a New Picture of Knowledge." New Insights in the Curriculum. Association for Supervision and Curriculum Development, N. E. A., 1963, pp. 57-70.
- Mead, G. H. Mind, Self and Society. Chicago: University of Chicago Press, 1934.

- Mead, Margaret. From the South Seas: Studies of Adolescence and Sex in Primitive Societies. New York: William Morrow and Co., Inc., 1939.
- Meals, D. "Heuristic Models for Systems Planning." Phi Delta Kappan, XLVIII, No. 5 (January, 1967), 199-203.
- Medinnus, Gene R., and Ronald C. Johnson. Child and Adolescent Psychology. New York: John Wiley and Sons, 1969.
- Miel, Alice. "Knowledge in the Curriculum." New Insights in the Curriculum, Association for Supervision and Curriculum Development, N. E. A., 1963, pp. 71-104.
- Miller, N. E., and J. C. Dollard. Personality and Psychotherapy. New York: McGraw Hill, 1950.
- Mouly, G. J. The Science of Educational Research. New York: American Book Co., 1965.
- Mower, O. H. Learning Theory and Personality Dynamics. New York: Ronald Press, 1950.
- Nagel, Ernest. "Philosophy of Science and Educational Theory." A paper presented at the National Philosophy of Education Meeting, March 29, 1961.
- Oxhandler, E. "Afterthoughts on a Systems Conference." Audio-Visual Instruction, Vol. 10, No. 5 (May, 1965), 395-396.
- Persselin, Leo. "Systems Implications for Secondary Education." Journal of Secondary Education, Vol. 44, No. 4 (April, 1969), 143-192.
- Phenix, Phillip H. Philosophy of Education. New York: Holt, Rinehart and Winston, 1958.
- Piaget, Jean. Psychology of Intelligence. Totowa, New Jersey: Littlefield and Adams, 1960.
- Piaget, Jean. Theory of Stages in Cognitive Development. New York: McGraw Hill, 1969.
- Rogers, Carl. "Toward Becoming a Fully Functioning Person." Perceiving, Behaving, Becoming, Association for Supervision and Curriculum Development, N. E. A., 1962, pp. 21-33.
- Rokeach, Milton. Beliefs, Attitudes and Values: A Theory of Organization and Change. New York: Jossey-Bass Inc., 1968.
- Rugg, Harold, ed. "The Foundation and Technique of Curriculum Construction." Twenty-Sixth Yearbook of National Society for the Study of Education. Bloomington, Illinois: Public School Publishing Co., 1926, pp. 109-161.

- Ryans, David G. "A Model of Instruction Based on Information Systems Concepts." Theories of Instruction. Eds. James B. MacDonald and Robert L. Leepers. Association for Supervision and Curriculum Development, N. E. A., 1965, pp. 36-61.
- Sand, Ole, and Donald A. Myers. "Creating a Productive Dialogue: Research, Discussion on Rationale." Rational Planning in Curriculum and Instruction, N. E. A., 1967, pp. 31-59.
- Schwab, Joseph. "Structure of the Disciplines: Meanings and Significances." The Structure of Knowledge and the Curriculum. Eds. G. W. Ford and Lawrence Pugno. Chicago: Rand McNally and Co., 1964, pp. 1-30.
- Scott, Harry V. "Primer of Curriculum Theory." Educational Theory, Vol. 18, No. 2 (Spring, 1968).
- Scriven, Michael. "The Structure of the Social Studies." The Structure of Knowledge and the Curriculum. Eds. G. W. Ford and Lawrence Pugno. Chicago: Rand McNally and Co., 1964, pp. 87-105.
- Sears, R. R., E. Macoby and H. Levin. Patterns of Child Rearing. Evanston, Illinois: Row Peterson, 1957.
- Shaw, Frederick. "The Changing Curriculum." Review of Educational Research, XXXVI, No. 3 (June, 1966), 349-350.
- Sidman, M. Tactics of Scientific Research. New York: Basic Books, 1960.
- Sills, David L. The Volunteers: Means and Ends in a National Organization. Glencoe, Illinois: The Free Press, 1957.
- Skinner, B. F. Science and Human Behavior. New York: Macmillan Co., 1953.
- Stern, C. Principles of Human Genetics. San Francisco: W. H. Freeman and Co., 1960.
- Symonds, P. M. The Dynamics of Parent-Child Relationships. New York: Appleton-Century Crofts, 1949.
- Taba, Hilda. Curriculum Development: Theory and Practice. New York: Harcourt, Brace and World, 1962, p. 6.
- Tanner, Daniel. "Curriculum Knowledge and Content." Review of Educational Research, XXXVI, No. 3 (June, 1966).
- Tanner, J. M. "Early Maturation in Man." Scientific American, No. 218 (1968), 21-27.
- Terman, L. M. The Measurement: An Explanation of and a Complete Guide for the Stanford Revision of the Binet Scale. Boston: Houghton Mifflin, 1916.



- Thompson, James D., and Frederick L. Bates. "Technology, Organization and Administration." Administrative Science Quarterly, No. 2 (1957), 325-343.
- Thorndike, E. L. The Fundamentals of Learning. New York: Teachers College, Columbia University, 1932.
- Timasheff, Nicholas S. Sociological Theory: Its Nature and Growth. New York: Random House, 1967.
- Tolman, E. C. "There Is More Than One Kind of Learning." Psychological Review, No. 56 (1949), 144-155.
- Travers, R. M. Essentials of Learning. New York: The Macmillan Co., 1963.
- Tyler, Ralph W. "The Interrelationship of Knowledge." The National Elementary Principal, XLIII, No. 4 (February, 1964), 13-21.
- Venable, Tom C. Philosophical Foundations of the Curriculum. Chicago: Rand McNally, 1967.
- Ward, Virgil S. "The Function of Theory in Programs for the Gifted." The Teachers College Record, Vol. 62, No. 7 (April, 1961), 532-539.
- Watson, J. B. Behaviorism. New York: W. W. Norton, 1930.
- Watson, J. B., and J. J. Morgan. "Emotional Reactions and Psychological Experimentation." American Journal of Psychology, No. 28 (1917), 163-174.
- Williams, R. J. A presentation to the Berkeley Conference on Personality Development in Childhood. Berkeley, California, University of California, May 5, 1960. (unpublished address).
- Williams, Robin M. American Society: A Sociological Interpretation. New York: Alfred A. Knopf, 1965.

VITA

Raymond D. Edman

Candidate for the Degree of

Doctor of Education

Dissertation: A SYSTEMATIC THEORY FOR CURRICULUM DEVELOPMENT AND  
INSTRUCTION IN AN ELEMENTARY SCHOOL

Major Field: Elementary Education

Biographical:

Personal Data: Born in Valparaiso, Indiana, January 16, 1926, the  
son of Mr. and Mrs. Raymond J. Edman.

Education: Graduated from Chesterton High School, Chesterton,  
Indiana, in May, 1944; attended Valparaiso University receiving  
the Bachelor of Science degree in 1951, with a major in  
Biology and Physical Education; received the Master of Educa-  
tion from University of Montana in 1959, with a major in  
Science Education; completed requirements for the Doctor of  
Education degree at Oklahoma State University in May, 1972  
with a major in Elementary Education and Curriculum.

Professional Experience: Teacher in the Chesterton, Indiana  
Public Schools 1951-57; teacher in the Great Falls, Montana  
Public Schools 1957-60; teacher at Alhambra High School,  
Martinez, California 1960-61; teacher in the Mt. Diablo  
Unified School District, Concord, California 1961-66; teacher,  
Portland State College Summer Workshop, 1966; consultant and  
workshop instructor for Biological Sciences Curriculum Study,  
University of Colorado, 1964-66; Assistant Director for the  
Educational Planning Center (PACE), Contra Costa County,  
Pleasant Hill, California, 1966-67; Assistant Superintendent-  
Curriculum in the Ceres Unified Schools, Ceres, California,  
1967-71.