

## DETERMINATION OF THE WIGNER FUNCTION FROM PHOTON STATISTICS\*

**K. Banaszek<sup>a 1</sup>, C. Radzewicz<sup>a</sup>, K. Wódkiewicz<sup>a,b</sup>, J. S. Krasinski<sup>c</sup>***(a) Wydział Fizyki, Uniwersytet Warszawski, Hoża 69, PL-00-681 Warszawa, Poland**(b) Abteilung für Quantenphysik, Universität Ulm, D-89081 Ulm, Germany**(c) Center for Laser and Photonics Research, Oklahoma State University,  
Stillwater, OK 74078, USA*

Received 15 April 1999, accepted 10 May 1999

We present an experimental realisation of the direct scheme for measuring the Wigner function of a single quantized light mode. In this method, the Wigner function is determined as the expectation value of the photon number parity operator for the phase space displaced quantum state.

PACS: 42.50.Ar, 03.65.Bz

The Wigner function provides a complete representation of the quantum state in the form that is analogous to a classical phase space probability distribution [1]. An interesting and nontrivial problem is how to relate the Wigner function to directly measurable quantities so that it can be determined from data collected in a feasible experimental scheme. The first answer was given by Vogel and Risken [2] who noted that marginal distributions of the Wigner function can be measured with a balanced homodyne detector, and that the inverse transformation is possible by tomographic back-projection. This idea has been realized in a beautiful experiment by Smithey and co-workers [3], and it has quickly become a useful tool in studying quantum statistical properties of optical radiation [4].

In this contribution we briefly review our recent experimental realization [5] of the direct scheme for measuring the Wigner function of a light mode [6, 7]. This method, based on photon counting, provides the complete Wigner representation of the quantum state without using any numerical reconstruction algorithms.

The basic idea underlying our experimental scheme is that the Wigner function  $W(\alpha)$  at a given phase space point  $\alpha$  is itself a well defined quantum observable. This observable can be represented as the expectation value of the displaced photon number parity operator:

$$W(\alpha) = \frac{2}{\pi} \left\langle \hat{D}(\alpha) \sum_{n=0}^{\infty} (-1)^n |n\rangle \langle n| \hat{D}^\dagger(\alpha) \right\rangle. \quad (1)$$

\* Presented at the 6th Central-European Workshop on Quantum Optics, Château Chudobín, Czech Republic, April 30 - May 3, 1999.

<sup>1</sup>E-mail address: Konrad.Banaszek@fuw.edu.pl

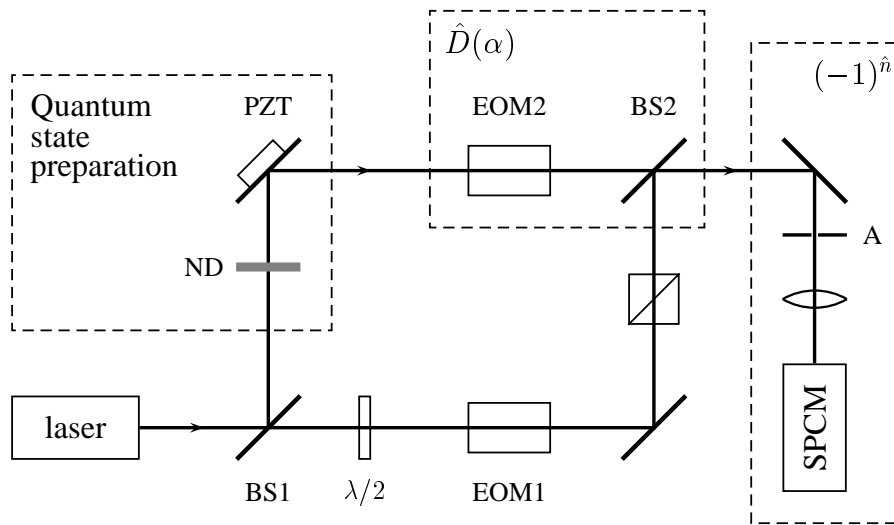

Fig. 1. The experimental setup for measuring the Wigner function of a single light mode. BS1 and BS2 are quartz plates serving as high-transmission beam splitters. The quantum state to be measured is prepared using the neutral density filter ND and the mirror mounted on a piezoelectric translator PZT. The electrooptics modulators EOM1 and EOM2 define the amplitude and the phase of the displacement  $\hat{D}(\alpha)$ . The quantum state, after applying the displacement transformation, is detected with the single photon counting module SPCM.

Here  $\hat{D}(\alpha) = \exp(\alpha\hat{a}^\dagger - \alpha^*\hat{a})$  denotes the displacement operator, and  $|n\rangle\langle n|$  are projections on Fock states. The two elements of the above expression: the displacement transformation and the projections on Fock states have a straightforward optical realisation. The displacement transformation can be implemented by interfering the signal field at a nearly fully transmitting beam splitter with a probe coherent field, and projections on Fock states are given by the photon statistics.

Our experimental scheme, presented in Fig. 1, is constructed as an unbalanced Mach-Zender interferometer with the beams in the two arms serving as the signal and the probe fields. The source of light is an attenuated beam from a frequency-stabilized single-mode He:Ne laser. The quantum state is prepared as a weak coherent state using the neutral density filter ND. Additionally, the mirror mounted on a piezoelectric translator PZT can be used to generate a statistical mixture of coherent states with fluctuating phase.

The displacement transformation  $\hat{D}(\alpha)$  is realized using the phase modulator EOM2 and the high-transmission beam splitter BS2 whose second input port is fed with a coherent probe beam. The modulator EOM2 performs rotation in the phase space, while the probe beam effectively shifts the phase space in a fixed direction. The value of the shift is proportional to the probe beam amplitude, which is controlled in the setup using the Pockels cell EOM1 placed between the half-wave plate and a polarizer. Thus, the point of the phase space at which the Wigner function is measured, is defined in our experiment by voltages applied to the modulators EOM1

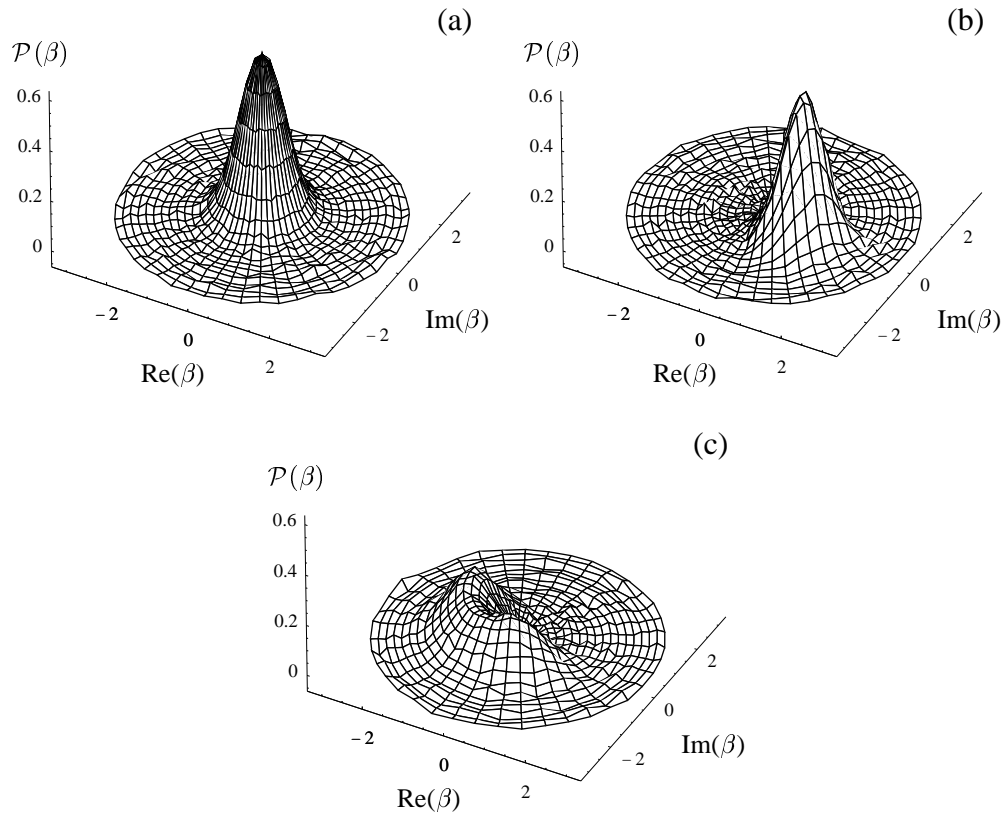

Fig. 2. The measured Wigner functions for (a) the vacuum, (b) a weak coherent state with approximately one photon, and (c) a phase diffused coherent state. The photon statistics was collected on a polar grid spanned by 20 amplitudes, and 50 phases for the plots (a) and (b), or 40 phases for the plot (c). The duration of a single counting interval was  $40 \mu\text{s}$  for (a) and (b) and  $30 \mu\text{s}$  for (c). The measurements were performed for slightly different laser intensity, and the radial coordinate for each of the graphs was scaled separately.

and EOM2.

The photon statistics of the displaced signal field is measured using an avalanche photodiode operated in the single photon counting module. The count rate is adjusted to the level such that a negligible fraction of photons is missed due to the detector dead time. The experiment is controlled by a computer, which collects photon statistics on a polar grid in the phase space.

In Fig. 2 we present experimental results obtained for the vacuum state, a coherent state, and a phase diffused coherent state. The scan for the vacuum state has been performed with the blocked signal path, and the phase diffused coherent state has been generated by applying a 400 Hz sine waveform to the piezoelectric translator. At each point of the grid, the photon

statistics has been collected from 8000 counting intervals. The graphs are parameterized with the complex variable  $\beta = n_{\text{vac}}^{1/2} e^{i\phi}$ , where  $n_{\text{vac}}$  is the average number of photons registered for the blocked signal path, and  $\phi$  is the phase shift generated by the modulator EOM2. The photon statistics  $p_n(\beta)$  collected at a point  $\beta$  is processed to yield

$$\mathcal{P}(\beta) = \frac{2}{\pi} \sum_n (-1)^n p_n(\beta). \quad (2)$$

In the ideal, loss-free limit this quantity is equal to the Wigner function of the signal field. In a realistic case,  $\mathcal{P}(\beta)$  can be related to a generalized  $s$ -ordered quasidistribution function  $W(\alpha; s)$ :

$$\mathcal{P}(\beta) = \frac{1}{\eta T} W\left(\frac{\beta}{\sqrt{\eta T}}; -\frac{1 - \eta T}{\eta T}\right), \quad (3)$$

where  $\eta$  is the quantum efficiency of the photodetector and  $T$  is the power transmission of the beam splitter performing the phase space displacement. The right-hand side of Eq. (3) can be interpreted as the Wigner function of the signal field that has passed through a dissipation process with the losses characterized by the overall efficiency  $\eta T$ . For our setup, the efficiency of the photon counting module specified by the manufacturer is  $\eta = 70\%$ , and the power transmission of the beam splitter BS2 is  $T = 98.6\%$ . This gives the value of the ordering parameter equal to  $s = 1 - 1/\eta T = -0.45$ .

Further details and discussion of various aspects of the experiment can be found in Ref. [5]. An important factor that should be taken into account in the analysis of experimental data is the mode-mismatch between the fields interfering at the beam splitter BS2. The effect of the mode-mismatch is quite different from balanced homodyne detection, where it can be included in the overall efficiency parameter. In the photon counting scheme, the mode-mismatch generates a slowly decaying gaussian envelope centered at the phase space origin, which multiplies the Wigner function of the signal field.

**Acknowledgments** This research is supported by the KBN grant 2P03B 002 14. K.W. thanks the Alexander von Humboldt Foundation for generous support and Prof. W. P. Schleich for his hospitality in Ulm.

## References

- [1] E. P. Wigner: *Phys. Rev.* **40** (1932) 749
- [2] K. Vogel, H. Risken: *Phys. Rev. A* **40** (1989) 2847
- [3] D. T. Smithey, M. Beck, M. G. Raymer, A. Faridani: *Phys. Rev. Lett.* **70** (1993) 1244
- [4] G. Breitenbach, S. Schiller, J. Mlynek: *Nature* **387** (1997) 471
- [5] K. Banaszek, C. Radzewicz, K. Wódkiewicz, J. S. Krasinski: *quant-ph/9903027*, to appear in *Phys. Rev. A*; see also <http://www.fuw.edu.pl/~kbanasz/QOLab/ExpWigner/>
- [6] S. Wallentowitz, W. Vogel: *Phys. Rev. A* **53** (1996) 4528
- [7] K. Banaszek, K. Wódkiewicz: *Phys. Rev. Lett.* **76** (1996) 4344