

THE EFFECTIVENESS OF DIATOMACEOUS EARTH FILTERS  
ON LAKE CARL BLACKWELL WATER

THE EFFECTIVENESS OF DIATOMACEOUS EARTH FILTERS  
ON LAKE CARL BLACKWELL WATER

By

WARREN E. HOXWORTH

Bachelor of Science

Oklahoma Agricultural and Mechanical College

Stillwater, Oklahoma

1950

Submitted to the Faculty of the Graduate School of  
the Oklahoma Agricultural and Mechanical College  
in Partial Fulfillment of the Requirements

for the Degree of

MASTER OF SCIENCE

1951

iii  
OYLENSA  
AGRICULTURAL & MECHANICAL COLLEGE  
LIBRARY  
MAY 9 1951

THE EFFECTIVENESS OF DIATOMACEOUS EARTH FILTERS  
ON LAKE CARL BLACKWELL WATER

WARREN E. HOXWORTH

MASTER OF SCIENCE

1951

THESIS AND ABSTRACT APPROVED:

*Quinton B. Graves*

Thesis Adviser

*Ray G. Saxton*

Faculty Representative

*Edward B. Stupay*

Dean of the Institute of Technology

*D. G. W. Zutsch*

Dean of the Graduate School

273800

## TABLE OF CONTENTS

|   | Page |
|---|------|
| Acknowledgement . . . . .                       | v.   |
| List of Illustrations . . . . .                 | vi.  |
| List of Symbols and Abbreviations . . . . .     | vii. |
| Chapter   |      |
| I. Introduction . . . . .                       | 1.   |
| II. Review of Previous Investigations . . . . . | 12.  |
| III. The General Problem . . . . .              | 14.  |
| IV. Scope of This Thesis . . . . .              | 16.  |
| V. Description of Equipment . . . . .           | 18.  |
| VI. Description of Diatomaceous Earth . . . . . | 25.  |
| VII. Procedure . . . . .                        | 28.  |
| Experimental Data . . . . .                     | 34.  |
| Graphs . . . . .                                | 57.  |
| VIII. Summary . . . . .                         | 63.  |
| IX. Discussion and Conclusion . . . . .         | 65.  |
| Bibliography . . . . .                          | 70.  |

## ACKNOWLEDGMENT

The author wishes to acknowledge his sincere appreciation for the guidance and suggestions of Professor Quintin B. Graves under whose direction this work was accomplished at the Oklahoma Agricultural and Mechanical College Water Treatment Plant.

Warm thanks are also due to Conrad P. Suman for his careful reading and helpful suggestions during the writing of this thesis and to Assistant Professor Nathan C. Burbank for his valuable advice and comments during the study.

Especial appreciation is due Bernice and Randall Berry, the author's sister and brother-in-law for their aid and encouragement throughout this study.

The writer also wishes to express indebtedness to his wife for her willing help and able criticism.

## LIST OF ILLUSTRATIONS

| Figure |  | Page |
|--------|--|------|
| 1.     | General Assembly of the Stellar Filters . . . . .                  | 6    |
| 1-A.   | Sketch Showing Operation of Filter . . . . .                       | 7    |
| 2.     | Filter Element . . . . .   | 9    |
| 3.     | Straining Action of Diatomaceous Earth . . . . .                   | 10   |
| 4.     | Filter Partly Disassembled . . . . .                               | 19   |
| 5.     | Schematic Flow Diagram . . . . .                                   | 20   |
| 6.     | Spectrophotometer . . . . .  | 22   |
| 7.     | Comparator . . . . .   | 22   |
| 8.     | Incubator and Refrigerator . . . . .                               | 23   |
| 9.     | Quebec Colony Counter . . . . .                                    | 23   |
| 10.    | Other Equipment . . . . .  | 24   |
| 11.    | Close View of Control Valves and Gages . . . . .                   | 24   |
| 12.    | Size Distribution Graph . . . . .                                  | 27   |
| 13.    | Petri Dishes With and Without Colonies of Bacteria . . . . .       | 32   |
| 14.    | Culture Tubes With and Without Gas Formers . . . . .               | 32   |
| 15.    | Characteristics of Diatomite Filtration During Test # 15 . . . . . | 57   |
| 16.    | Characteristics of Diatomite Filtration During Test # 30 . . . . . | 58   |
| 17.    | Characteristics of Diatomite Filtration During Test # 38 . . . . . | 59   |
| 18.    | Characteristics of Diatomite Filtration During Test # 40 . . . . . | 60   |
| 19.    | Characteristics of Diatomite Filtration During Test # 43 . . . . . | 61   |
| 20.    | Characteristic of Diatomite Filtration During Test # 45 . . . . .  | 62   |

## LIST OF SYMBOLS AND ABBREVIATIONS

|                    |     |                            |
|--------------------|-----|----------------------------|
| $^{\circ}\text{C}$ | --- | degree centigrade          |
| Eff                | --- | effluent                   |
| $\text{ft}^2$      | --- | square feet                |
| gpm                | --- | gallons per minute         |
| min                | --- | minutes                    |
| ml                 | --- | milliliter                 |
| oz                 | --- | ounces                     |
| pH                 | --- | hydrogen-ion concentration |
| ppm                | --- | parts per million          |
| psi                | --- | pounds per square inch     |
| Inf                | --- | influent                   |

## CHAPTER I

### INTRODUCTION

Existing evidence indicates that man had realized the need for, and had made some progress in obtaining, a safe and attractive quality of water as early as 2000 B. C.<sup>1</sup> A safe supply of water is one which can be consumed without causing illness to the consumer because of matter of any nature contained in the water. Attractiveness pertains to the physical appearance of the water. It does not follow that an attractive water is safe; likewise, it is not true that all unattractive waters are unsafe. These physical properties of water that cause unattractiveness include mainly odor, taste, color, temperature and turbidity.<sup>2</sup>

Odors in water are noticed by all of us and require no real explanation here other than to mention that they are usually caused by chemical or biological agents. Closely associated with odors are tastes. While the name implies the sense affected by tastes, the causative agents are identical to those of odors. Color is given to water by mineral or organic colloids and suspensions. Little has to be said of the desirability of drinking water having the proper temperature. Water too warm is much less desirable than water too cold. However, for optimum quality, water should be between 40°F and 50°F. Since turbidity removal is the major function of filtration, a complete discussion of the nature of turbidity would seem appropriate here.

Most engineers prefer to define turbidity as a measure of the suspended or colloidal matter which interferes with its clarity. This matter may con-

---

<sup>1</sup> The Hindu System of Medicine According to Sus'ruta, Vol. XCV, pp. 215-22, cited by M. N. Baker, The Quest for Pure Water, p. 1.

<sup>2</sup> Harold E. Babbitt and James J. Doland, Water Supply Engineering, pp. 412-15.



sist of clay, silt, fine particles of organic matter or microscopic organisms.<sup>3</sup> The turbidity of the water may be measured with any instrument capable of indicating comparative clarities of liquids. The actual standard unit of turbidity is defined by the American Public Health Association as that turbidity produced when one part per million of Fuller's or diatomaceous earth is contained in any sample of water. To clarify the term part per million, it might be easier to think of it as identical to one unit weight of any substance contained in one million unit weights of water.<sup>4</sup>

The forgoing information provides a foundation upon which to base the structure for further discussion of turbidity. This discussion will attempt to break turbidity down into three general classifications and investigate the composition as well as the importance of these classes on the health and economy of a community. All turbidity may be classed broadly as mineral, plant or animal depending on the origin of the substance.

Mineral turbidity consists of the silts and clays in particular and may be found in sizes smaller than 0.001 inches. This type of turbidity has no sanitary importance other than the lessening of the aesthetic qualities of the water, unless some part of this mineral turbidity contains chemical substances poisonous to the consumer. It might be noted here that chemical impurities (causing turbidity) in the water supply have been grouped under the general heading of mineral turbidity.

Plant life contained in water contributes greatly to the turbidity of the water at times. However, if the kind of plant life is minute in size and

---

<sup>3</sup> F. E. Turneure and H. L. Russell, Public Water Supplies, p. 153.

<sup>4</sup> American Public Health Association and American Water Works Association, Standard Methods for the Examination of Water and Sewage, p. 10.

the concentrations in the water are small, there is doubt as to just how much turbidity might be imparted to the water. Plant life in water may be divided into those that cause illness, the pathogens, and those that apparently cause man no ills but rather aid him in the daily cycles of life. One of these harmless plants seen at times in various bodies of water is the Algae or pond scum. This plant causes no ills in man but does present an enormous problem to those trying to produce taste and odor free water. It might prove interesting to note here that diatoms, the fossils which are the prime consideration in this thesis, belong to the Algae phyla. Plants causing illness to man and animal are unfortunately too small to be seen with the naked eye. These microscopic organisms usually fall under the classification of bacteria. Some pathogenic bacteria found in water are: *Eberthella typhosa*, the causative agent in typhoid fever; *Spirillum cholerae*, the bacteria causing cholera; and *Bacillus dysenteriae*, the organism producing the symptoms of bacillary dysentery.

Animal life found in water affects man in much the same manner as the plant life described previously. There are those types of animal microscopic organisms helpful to man and also those that are classified as pathogens. The bacteria are not in this group since they are plants. Types of animal organisms commonly found in water are the protozoa, rotifera, crustacea, bryozoa and porifera.<sup>5</sup> The most dangerous pathogenic forms of animal life are *Endameba hystolytica*, the cause of amebic dysentery, and the Cercariae (larval flakes) of the Schistosome, the cause of schistosomiasis.

The task of rendering these living organisms harmless in the water supply is not usually that of the filter. Many methods of disinfection are

---

<sup>5</sup> George Chandler Whipple, Gordon Maskew Fair and Melville Conley Whipple, The Microscopy of Drinking Water, p. 13.

used to kill those forms of life considered dangerous to the user. However, *Endameba hystolytica* is usually considered resistant to chlorination when applied without the benefit of laboratory control.<sup>6</sup> The *Cercariae* of the Schistosome is another organism quite resistant to chlorination.<sup>7</sup> This leaves the alternative of removing these organisms by some other means, and the practical means is one of filtration. When operated at high rates, the sand filter will not remove these organisms.<sup>8</sup> But the United States Public Health Service demonstrated that diatomite filtration of water effects complete removal of the cysts of *Endameba hystolytica* and the *Cercariae* of the Schistosome.<sup>9</sup> These facts point to the limited use of the diatomaceous earth filter in removal of pathogens from water.

It must be remembered that the prime purpose for the use of most filters is the removal of turbidities for the clarification of water and not the removal of disease causing organisms. The reason for this being that most forms of life causing illness in man may pass through any ordinary filter. It is, therefore, safest to depend on chlorination for the sterilization of water and to use the straining action of the filter medium to remove turbidity. Perhaps the best vindication for producing an attractive safe water rather than sparing the additional expense and distributing a safe water that may not be attractive is the fact that consumers will be driven from unattractive safe water to sources of clear water that are often unsafe.<sup>10</sup>

---

<sup>6</sup> George C. Dunham, Military Preventive Medicine, p. 176.

<sup>7</sup> Milton J. Rosenau, Preventive Medicine and Hygiene, p. 431.

<sup>8</sup> Hayse H. Black and Charles H. Spaulding, "Diatomite Water Filtration Developed for Field Troops," Journal American Water Works Association. XXXVI (November, 1944), 1208.

<sup>9</sup> Ibid., p. 1221.

<sup>10</sup> Turneure and Russell, op. cit., p. 152.

The development of the pressure type diatomaceous filter arose from the need for a compact, efficient high rate filter to service United States Army field troops. Since the rapid sand filter, when filtering at high rates, would not do the work, the diatomaceous type pressure filter principle was borrowed from the chemical industry and adapted for use with water.

The operation of the diatomite filter as finally developed, shown in Figure 1-A, entails essentially the use of two pressure vessels divided by a separator plate. The purpose of the separator plate is to offer a support for the filter elements and at the same time guard against any liquid passing from the influent vessel to the effluent vessel without first passing through the filter element. The filter element supplies the foundation for the diatomaceous earth filter aid. The element, as seen in Figure 2, is in essence a hollow cylinder the surface of which consists of fine stainless steel wire, sparsely wound on a fluted form in such a manner that minute openings exist between the wires. These openings are small enough to catch and hold the diatomaceous earth in a straining action as the mixture of diatomite and water try to pass. This action is pictured in Figure 3. This straining action builds up a layer of diatomite called the "filter cake" which is the filtering medium in the turbidity removal process.

When the filtering cycle is at an end and cleansing of the filter cake from the element is desired, a pressure is built up on both sides of the element. This is done by first closing the effluent valve allowing the pump to develop its maximum head across the filter cake and then closing the influent valve. The quick opening valve, located on the influent pressure vessel, is then quickly opened allowing liquid to leave this vessel and flow to waste. This causes a sudden drop in pressure on the influent side of the filter element actually "exploding" or "bumping" the filter cake from the

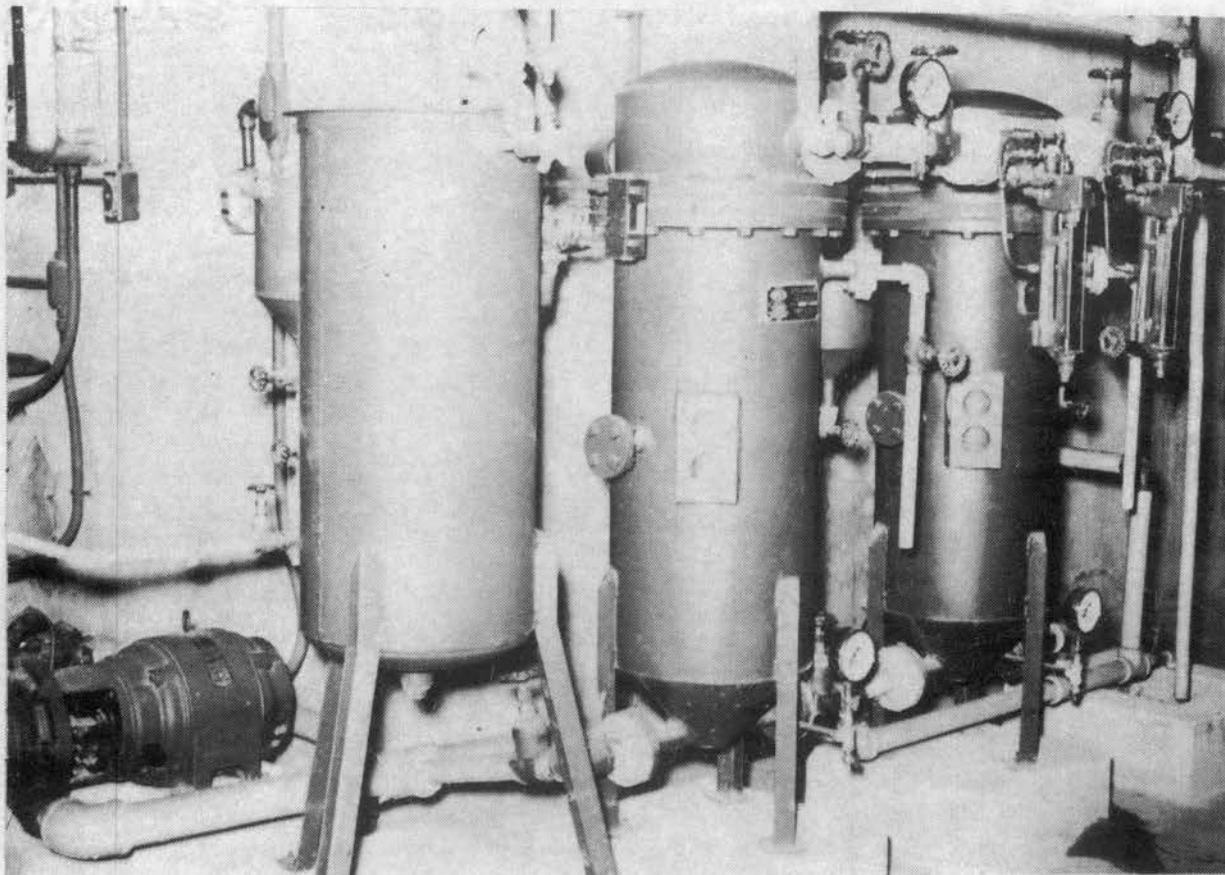

Figure 1. General Assembly of the Stellar Filters

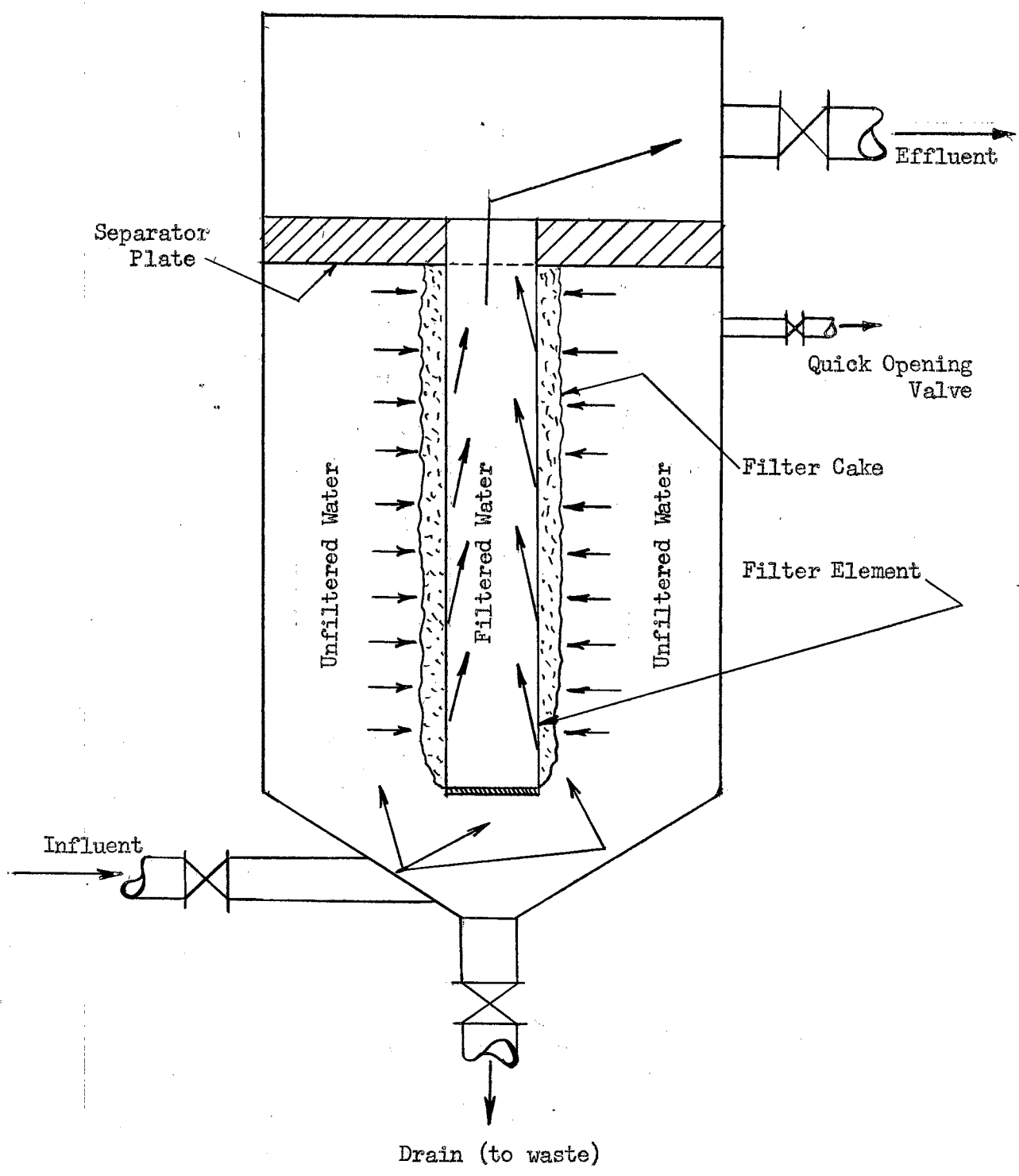

Figure 1-A. Sketch Showing Operation of Filter.

filter element. The earth then settles to the bottom of the influent vessel to await draining or redepositing on the element for re-use in another cycle.

Throughout this introduction numerous references have been made to diatomaceous earth. Deposits of the fossil remains of minute aquatic plants called diatoms are the source of diatomaceous earth. These plants, microscopic in size, grew profusely in the prehistoric Pacific Ocean during the Miocene Period, several million years ago. As the plants died they settled to the ocean floor, fossilized and there remained in beds over 1000 feet thick until some geologic upheaval lifted them into what now is a part of the coastal mountains.<sup>11</sup> Some sources of information state that it is possible that these diatomaceous beds were deposited as recently as 100,000 years ago.<sup>12</sup>

While the size of the diatom is measured in thousandths of an inch, their structure is one of delicate beauty fashioned in over 10,000 different intricate patterns having always a basic simple symmetry. One might find the closest rival to the beauty of the diatom in the snowflake.

These tiny "skeltons" are composed of silica extracted from the water during their life cycle. The physical structure of the fossil material contains some 90 percent voids and 10 percent silica. These voids give the diatomite excellent characteristics as a filter aid. Relatively few types of diatoms are of commercial value, however, there seems to be a plentiful supply of the suitable types.

In summary this introduction has endeavored to integrate the following related topics:

---

<sup>11</sup> "Celite Filter-Aids and Mineral Fillers," Johns-Manville DS Series 450, (New York: Johns-Manville, 1943).

<sup>12</sup> "Dicalite Diatomaceous Aids to Industry," Technical Service Bulletin, No. B-12, (New York: Great Lakes Carbon Corp., 1949).

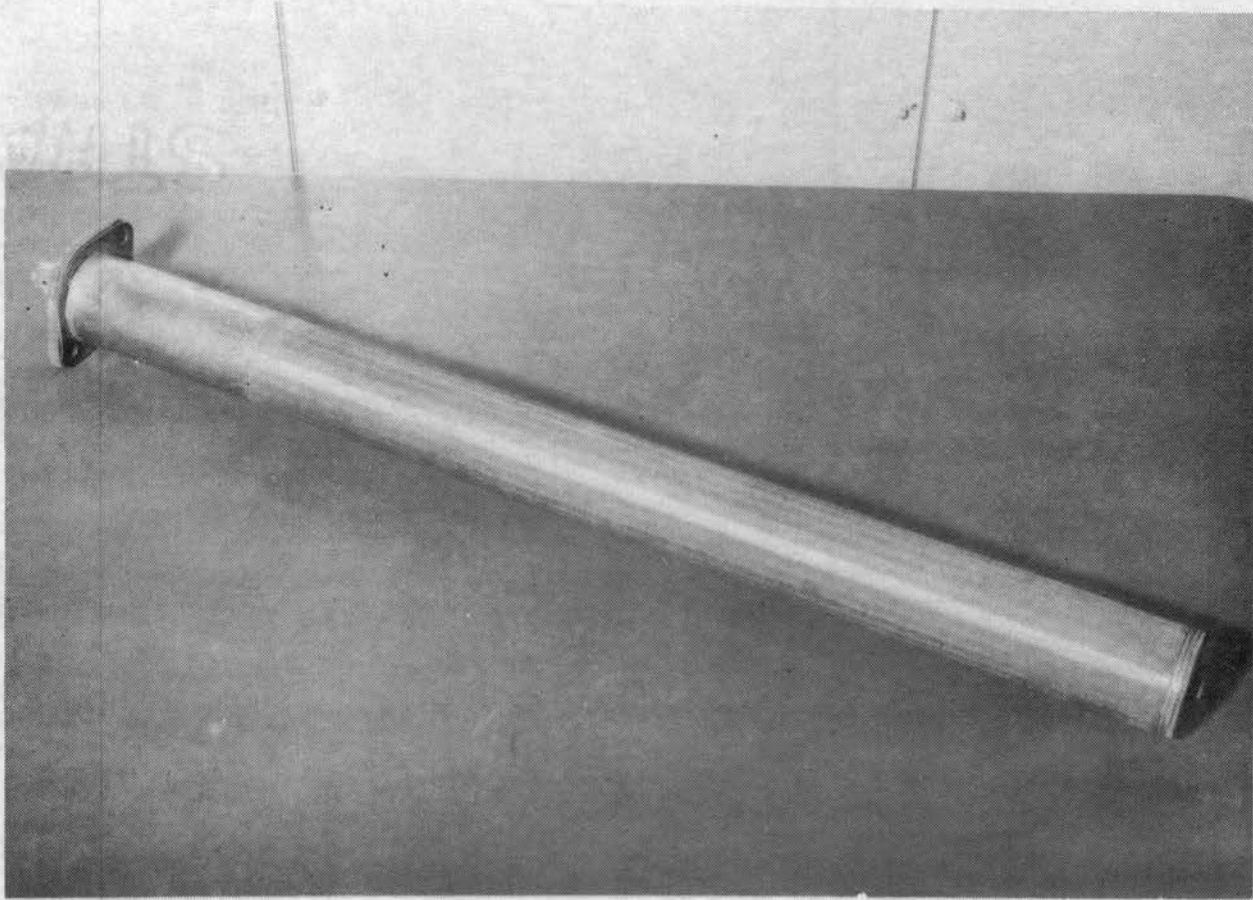

Figure 2. Filter Element



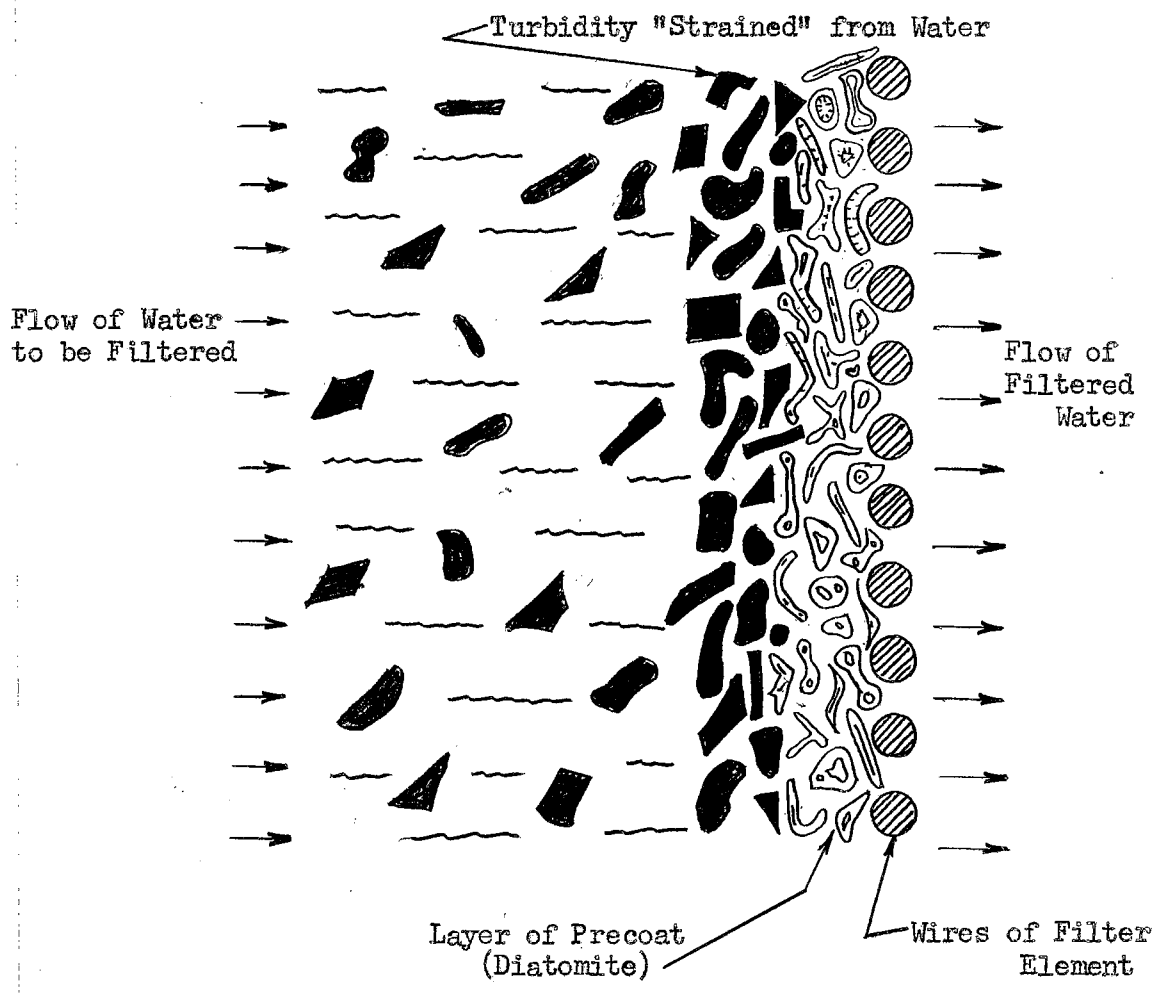

Figure 3. Straining Action of Diatomaceous Earth.

1. The physical properties of water most of which are related to turbidity.
2. A full discussion of turbidity as it applies to this thesis.
3. Why turbidity in any of its forms should be removed from water.
4. The capabilities and limitations of sand and diatomaceous earth filters under certain conditions.
5. The principle of operation of the diatomite filter.
6. A discussion of diatomaceous earth.

## CHAPTER II

## REVIEW OF PREVIOUS INVESTIGATIONS

Available literature indicates that the greatest amount of work done in connection with the adaptation of the diatomite filter to water purification was done under the direction of Black and Spaulding<sup>13</sup> at the Engineer Board, Ft. Belvoir, Virginia. With the aid of the National Institute of Health and several manufacturing concerns, it was possible for the Engineer Board to develop a diatomite filter particularly adapted to field use. The result obtained with this filter indicated that the military use might only be the beginning of the various possible uses of diatomite filtration in water purification.

A. B. Cummins<sup>14</sup> contributed a most useful quantity of information concerning the relationship existing between several kinds of filter aids and different qualities of suspended particles. His findings indicate that the flow characteristics are affected by the shape of the diatomaceous material. And Elsenbast and Morris<sup>15</sup> highlighted the diatomaceous filtering process from the mechanical point of view. They also showed the wide range over which the diatomaceous earth particle size may vary. An example of this variation in Hyflo Super-Cel is as follows:

| <u>Particle Size</u><br>(Microns) | <u>Hyflo Super-Cel</u><br>(%) |
|-----------------------------------|-------------------------------|
| > 40                              | 6.0                           |
| 40-20                             | 15.5                          |
| 20-10                             | 33.5                          |
| 10-6                              | 22.0                          |
| 6-2                               | 21.5                          |
| < 2                               | 1.5                           |

---

<sup>13</sup> Black and Spaulding, op. cit., 1208-21.

<sup>14</sup> A. B. Cummins, "Clarifying Efficiency of Diatomaceous Filter Aids," Industrial and Engineering Chemistry, XXXIV (April, 1942), 403-11.

<sup>15</sup> A. S. Elsenbast and D. C. Morris, "Diatomaceous Silica Filter-Aid Clarification," Industrial and Engineering Chemistry, XXXIV (April, 1942), 412-18.

Kiker<sup>16</sup> investigated the use of diatomite as a means of removing turbidity from swimming pool water. He used only one grade, Celite 545, and found the results to be highly satisfactory.

Chang and Fair<sup>17</sup> contributed the bacteriological information that the cysts causing amebic dysentery are highly resistant to chlorination. Rosenau<sup>18</sup> credits Leiper with the statement that bilharzia cercariae are very resistant to chlorine. Black and Spaulding<sup>19</sup> credits the National Institute of Public Health, United States Public Health Service for demonstrating that diatomite water filtration completely removes the chlorine resistant causative agents of the diseases amebic dysentery and schistosomiasis.

Possibly other information has been obtained in relation to diatomite filtration. However, no record of such additional investigation is available to the writer.

---

<sup>16</sup> John E. Kiker, "Diatomite Filters for Swimming Pools," Journal American Water Works Association, IX (September, 1949), 801-9.

<sup>17</sup> S. L. Chang and Gordon M. Fair, "Viability and Destruction of the Cysts of Endameba histolytica," Journal American Water Works Association, XXXIII (October, 1941), 1705.

<sup>18</sup> Rosenau, loc. cit.

<sup>19</sup> Black and Spaulding, op. cit., 1220.

## CHAPTER III

## THE GENERAL PROBLEM

Since the investigations already made with the diatomaceous earth filter cover only a small portion of this countries water sources, it would seem to be most worthwhile to thoroughly investigate different waters with due regard to the quantity and types of turbidity carried therein. This being done, the compilation of a compendium on the capabilities and limitations of the diatomaceous earth filter would prove invaluable in the solution of specific water filtering problems, the answers to which might otherwise remain undiscovered.

Another aspect of the problem is to discover just what water sources in any given areamight be susceptible to satisfactory filtration either with or without preconditioning of the raw water. The ultimate aim of this investigation would be to become familiar with the final results obtainable from the supplies available thus enabling a predetermined plan of action that would guarantee a suitable supply of water to a given community in the event of an emergency of major proportion. The author has in mind the possibility of mobile diatomaceous type filters being moved into an area needing a life sustaining quantity of water. This need could well arise from the acts of God or the wrath of man.

It would appear that a most important item in our general plan for national defense should include exhaustive studies as to how an obliterated or radiation contaminated water supply could be replaced in the shortest possible time.

At one time it might have appeared possible to supplant the rapid sand filter with this high rate, space saving method of filtration.<sup>20</sup> How-

---

<sup>20</sup> S. B. Applebaum, "Filtration of Water Through Diatomaceous Earth," Water and Sewage Works, XCIII (August, 1946), 308-10.

ever, with few exceptions, this substitution now seems remote in view of the investigations and convincing arguments for increasing the present standard rate of two gallons per minute per square foot of sand filter surface of the rapid sand type filter<sup>21</sup> up to as much as four or even five gallons per minute per square foot. More work should be done before this seemingly obvious conclusion is declared a fact, especially in view of the results obtained when the body feed method is used in diatomaceous earth filtration.<sup>22</sup> In the body feed method, diatomite is added to the water to be filtered to provide porosity in the material deposited on the precoat.

It has been indicated that body feed enables higher filter rates over longer periods of time when the liquid to be filtered is water. Additional investigation of various types of water would be required before it could be determined whether the British system of no body feed or the system of body feed used most widely in the United States is more desirable for use with a particular type of water. Before it can be considered feasible to use the body feed method in diatomite filtration, such factors as total cost per unit quantity of water produced, initial and maintenance cost of body feed equipment and increased complexity of the filter cycle must be weighed as to all their advantages and disadvantages. Obviously the results of these investigations would depend in part on the type of water used.

---

<sup>21</sup> John R. Baylis, "Are We Ready for High-Rate Filtration of Water?" Water and Sewage Works, XCVII (November, 1950), 456-58.

<sup>22</sup> Black and Spaulding, op. cit., 1213-15.

## CHAPTER IV

## SCOPE OF THIS THESIS

The purpose of this thesis is to show the effectiveness of the diatomaceous earth filter on Lake Carl Blackwell water.

The investigation was confined to the operation of the filter with a layer of diatomite deposited on the filter element from a slurry mixture of diatomaceous earth and water. This initial filtering layer, free from any additional diatomite fed to the influent water, is called the precoat. Data as to what may be expected from these same conditions when using the body feed method of filtration lies beyond the scope of this paper.

All experiments were carried out with the aim of obtaining specific information concerning the ability of the diatomaceous earth filter, to remove turbidity and bacteria, particularly organisms of the "coliform group". The "coliform group" may be considered to be all aerobic and facultative anaerobic bacilli which give off gas when fermenting lactose. These bacteria are Gram-negative non-spore-forming.<sup>23</sup> It was also most desirable to ascertain the probable rate of flow through the filter when the removal of the turbidity and coliform organisms is satisfactory.

Since the turbidities of the filter influent varied over moderate ranges in both the raw and settled waters, and since these variations are typical of what may be found under actual field conditions, no effort was made to standardize the influent turbidities. However, comparative results were made possible by computing the percent removal of turbidity at critical time intervals.

Standard Methods for making bacterial plate counts and for determining the

---

<sup>23</sup> American Public Health Association, *op. cit.*, p. 193.

most probable number of coliform organisms was used in obtaining data from the bacterial analysis of all test samples. These test samples were taken at random times from all waters to be tested so that the end results would represent true probabilities.

Control of the influent temperature was practically impossible and the resulting variations in the rate of flow caused by temperature-viscosity relationships are of an extremely complicated nature. With fine grain clean sands, the equations<sup>24</sup> concerning the flow characteristics are complex and inexact and logic would dictate that no more precise formulae could be expected concerning diatomite flow properties than the equations derived for sand. The presence of so many variables, some of which are most difficult to approximate, dictates that the effects of temperature change lies beyond the scope of this thesis and exists as an error in the results. However, since the temperature changes encountered during this study were less than those frequently found in the field, the writer feels that the neglect of such effects do not materially alter the findings.

Having all the apparent water borne variables either correctly eliminated as inconsequential to the desired data or reduced to the form where proper comparisons are possible, only the grade and manner of use of the diatomaceous earth remained subject to variation. Assuming this knowledge to be true within the bounds of accuracy desired in this investigation, the diatomite grade and weight per square foot of filter area were varied on each filter run. It was thus possible to gather data which would indicate the most probable practical combination of weight and grade giving a satisfactory effluent.

---

<sup>24</sup> American Society of Civil Engineers, Water Treatment Plant Design, pp. 53-59.



## CHAPTER V

## DESCRIPTION OF EQUIPMENT

The equipment used to make this study included the following major items:

1. Filters - two Stellar Filters manufactured by Infilco, Inc., Chicago, Illinois, size SW-9-E. Each filter, as shown partly disassembled in Figure IV, has nine square feet of filter area. Each filter is complete with its own influent and effluent pressure gage, rate of flow meter, observation port, diatomite charger and quick opening release valve. The release valve is used in bumping the filter. The battery of filters has a Hi-Cap Feeder, manufactured by Infilco, Inc., Chicago, Illinois, for the purpose of feeding diatomaceous earth as body feed, but the feeder was not used in this study. Figure V is a flow diagram of the installation showing how raw or settled influent may be filtered through either or both filters wasting the filtered effluent until its quality is satisfactory. The terms settled water and coagulated water will be used interchangeably hereafter and will refer to a water that has been coagulated with chemicals and settled. When the quality is suitable for the desired use, it may be seen that the waste valves can be closed and the water filtered to storage.
2. Pump - the pump is a Fairbanks, Morse & Co., "Builttogether" centrifugal pump capable of delivering 150 gallons per minute against a head of 120 feet. The pump is powered by a 7.5 horsepower alternating current, squirrel cage motor.
3. Spectrophotometer - the turbidities of all tested samples were determined by the use of the Coleman Model 14 Spectrophotometer.<sup>25</sup>

---

<sup>25</sup> Operating Directions for the Model 14 Coleman Universal Spectrophotometer, (Maywood: Coleman Instruments, Inc., 1947), p. 24.

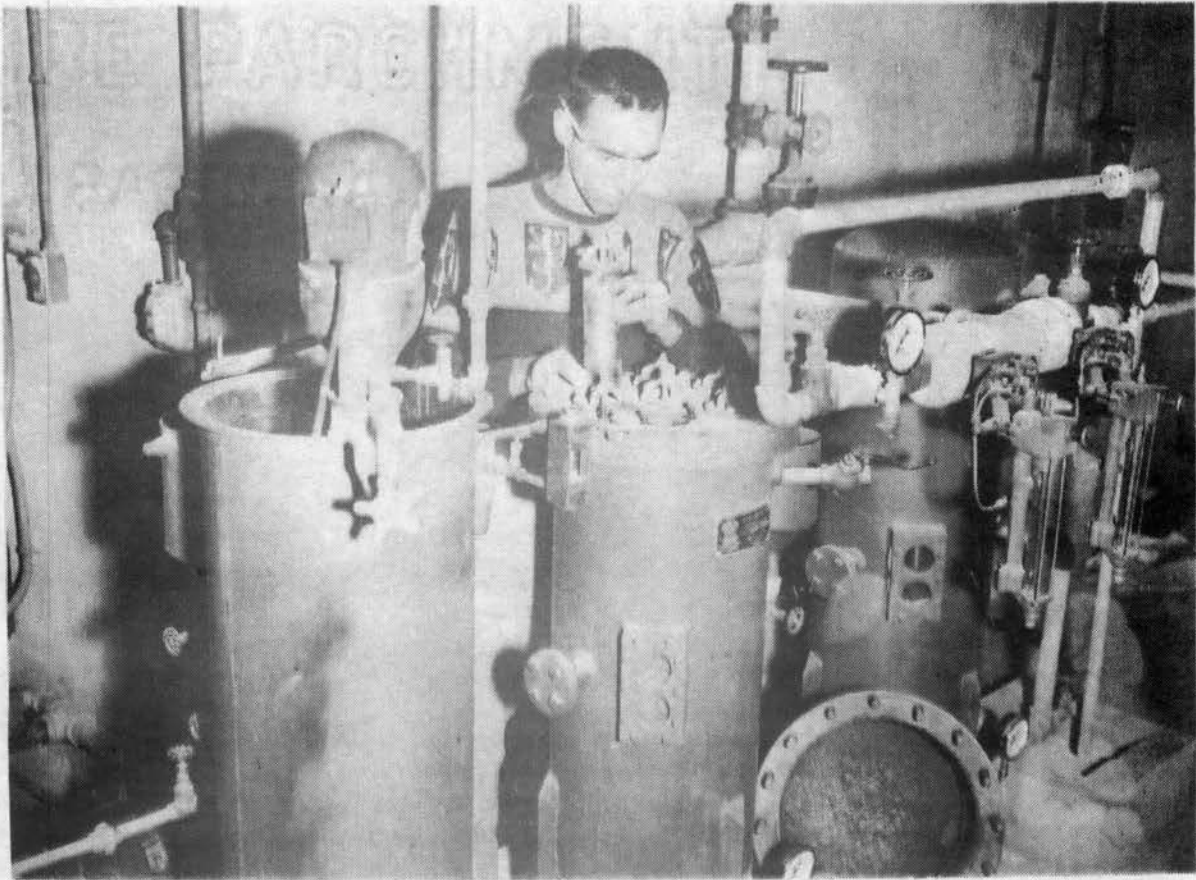

Figure 4. Filter Partly Disassembled

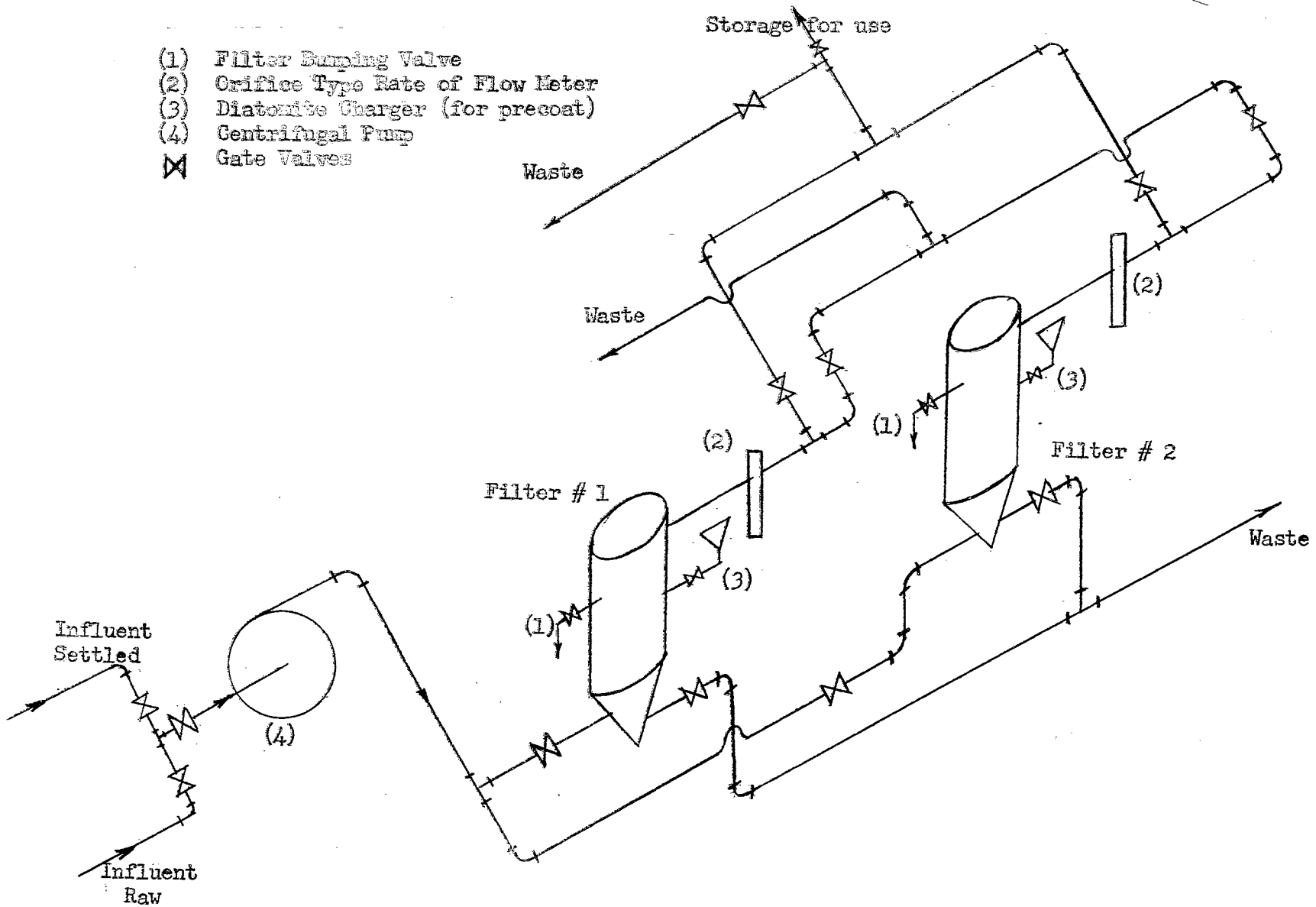

Figure 5. Schematic Flow Diagram

Figure VI shows this instrument.

4. Comparator - the Hellige Comparator Model No. 611 was used on several runs to ascertain whether or not any change in the hydrogen-ion concentration occurred. Space is not available here for the discussion of hydrogen-ion concentration and pH but Babbitt and Doland<sup>26</sup> give a clear explanation of this phenomenon. A photograph of this instrument may be seen in Figure VII. The comparator was also used to measure color in the water.
5. Incubator - Figure VIII shows the incubator used to run the bacteriological tests for organisms of the coliform group. The test tubes shown in the photograph are portions of a sample under observation for presence of coliform organisms. The petri dishes shown are being used to make plate counts<sup>27</sup> of the same sample.
6. Refrigerator - the refrigerator used to keep all culture media at the proper temperature is shown in Figure VIII.
7. Quebec Colony Counter - in Figure IX is seen the device used to facilitate expeditious and accurate counting of the bacteria on the petri dishes or plates. A plate ready for counting is seen in place on the instrument.
8. Other Equipment - Figure X shows the analytical balance and weights, stopwatch, centigrade thermometer and mixing pail used in the experiments.

---

<sup>26</sup> Babbitt and Doland, op. cit., pp. 418-21.

<sup>27</sup> American Public Health Association, op. cit., pp. 191-93.

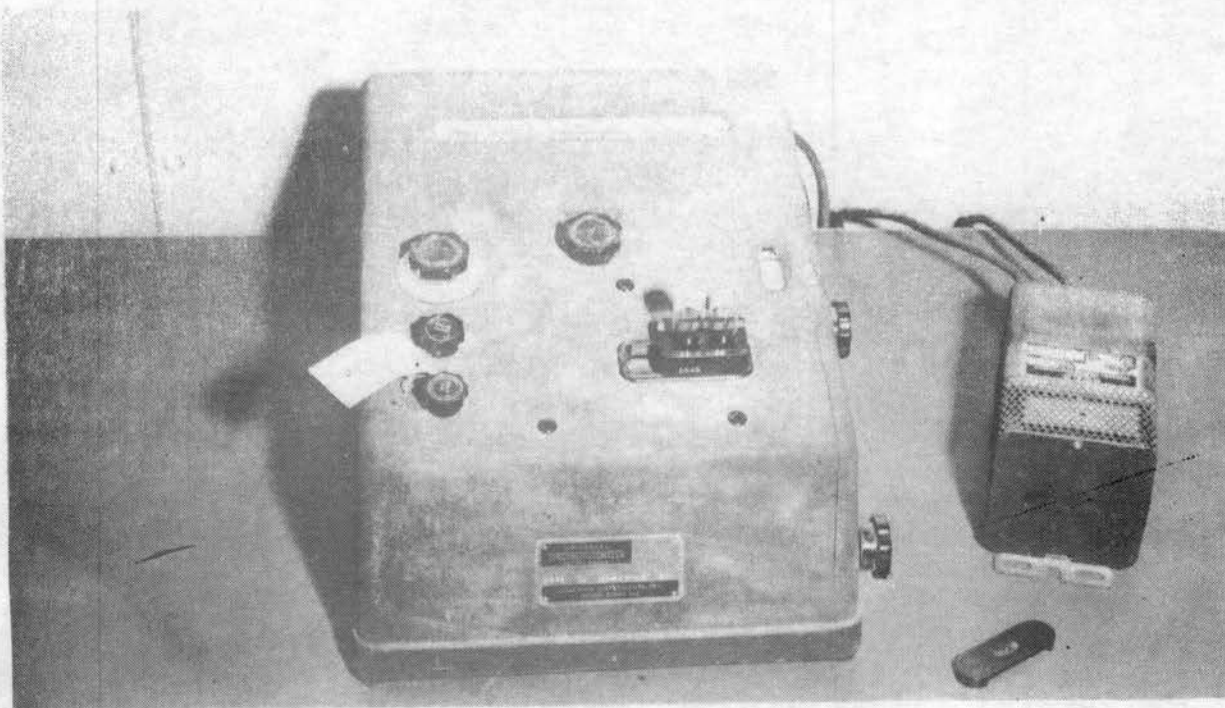

Figure 6. Spectrophotometer

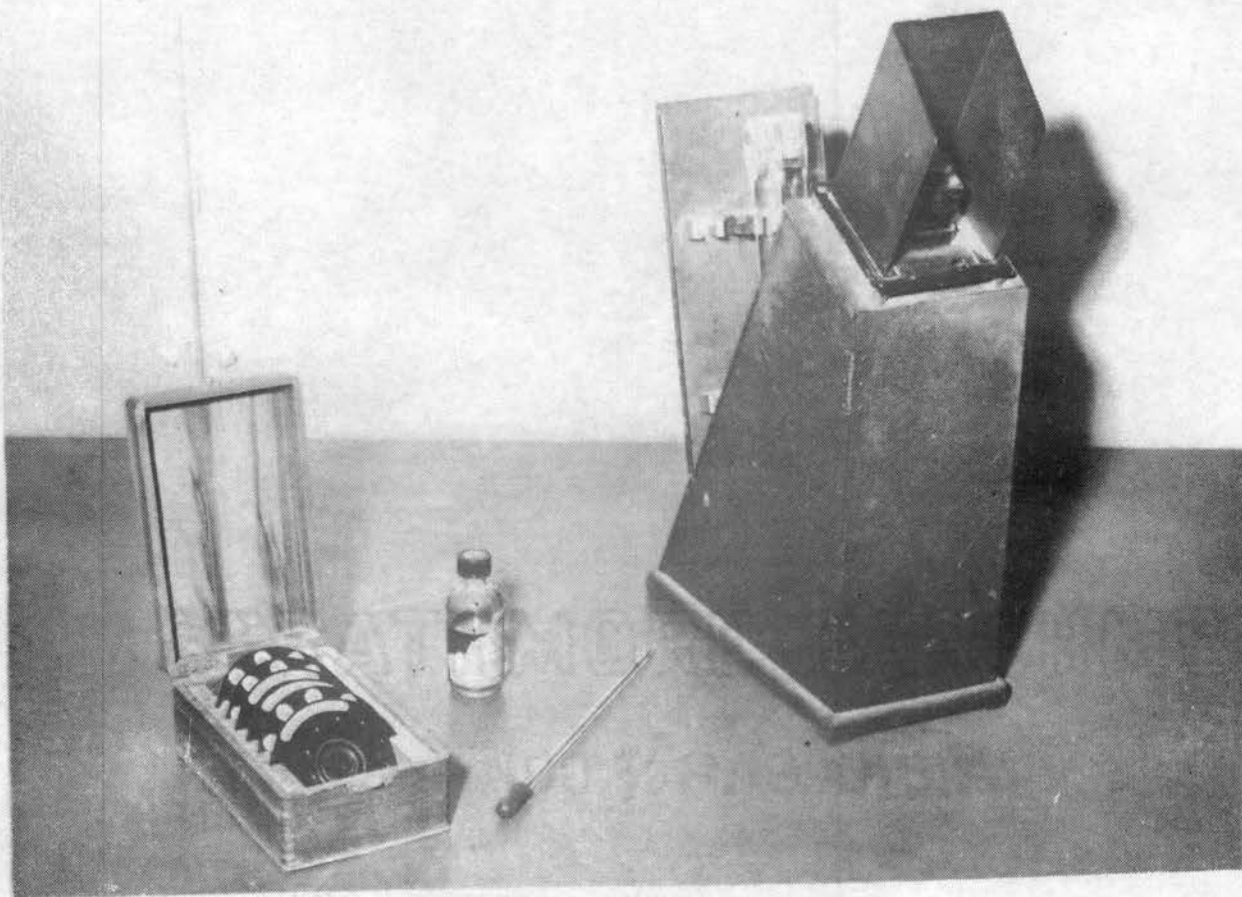

Figure 7. Comparator

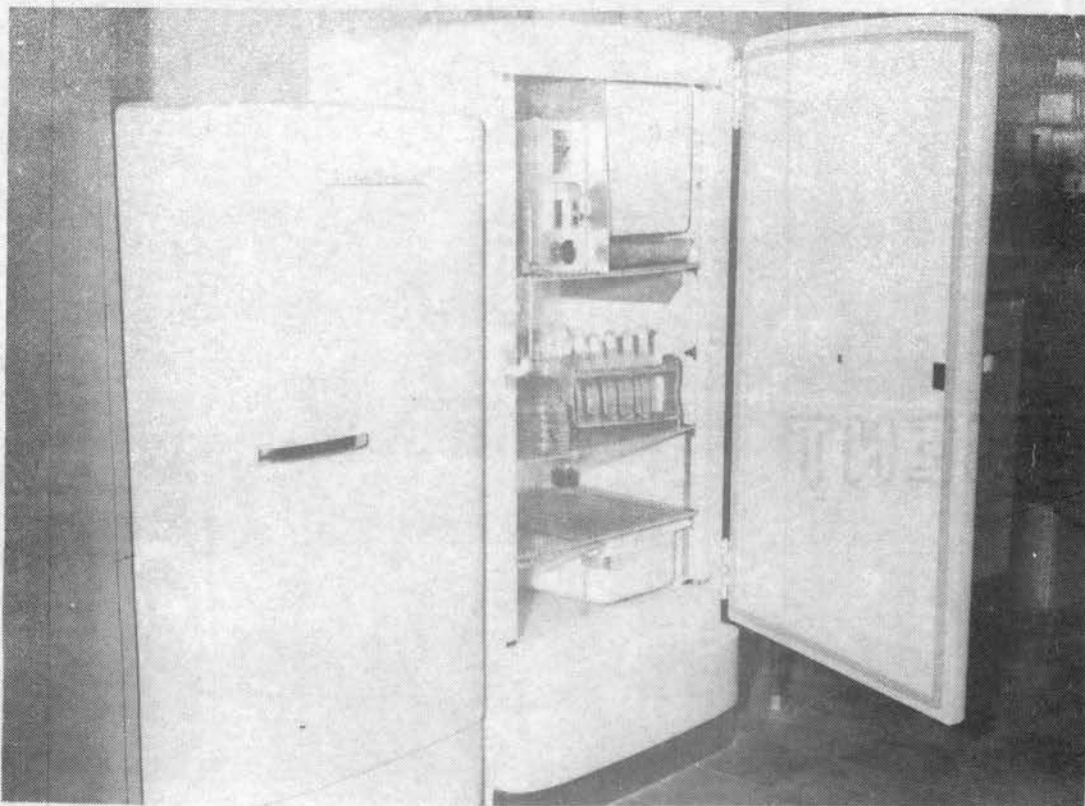

Figure 8. Incubator and Refrigerator

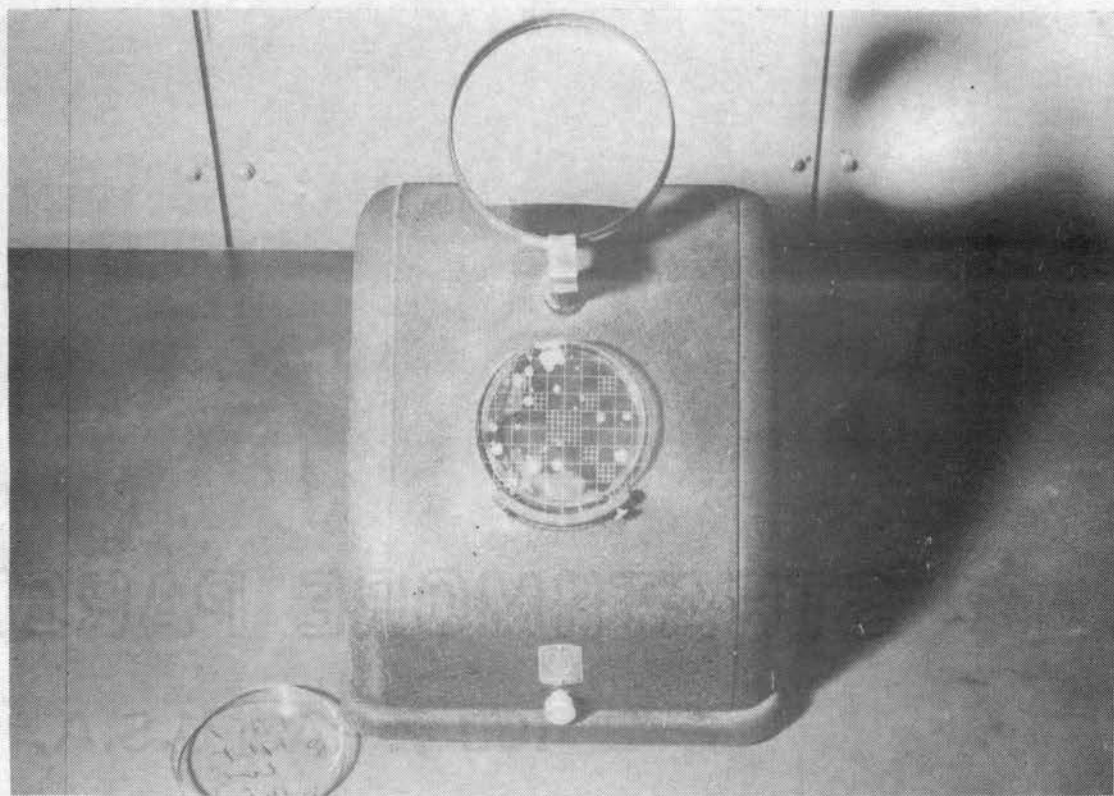

Figure 9. Quebec Colony Counter

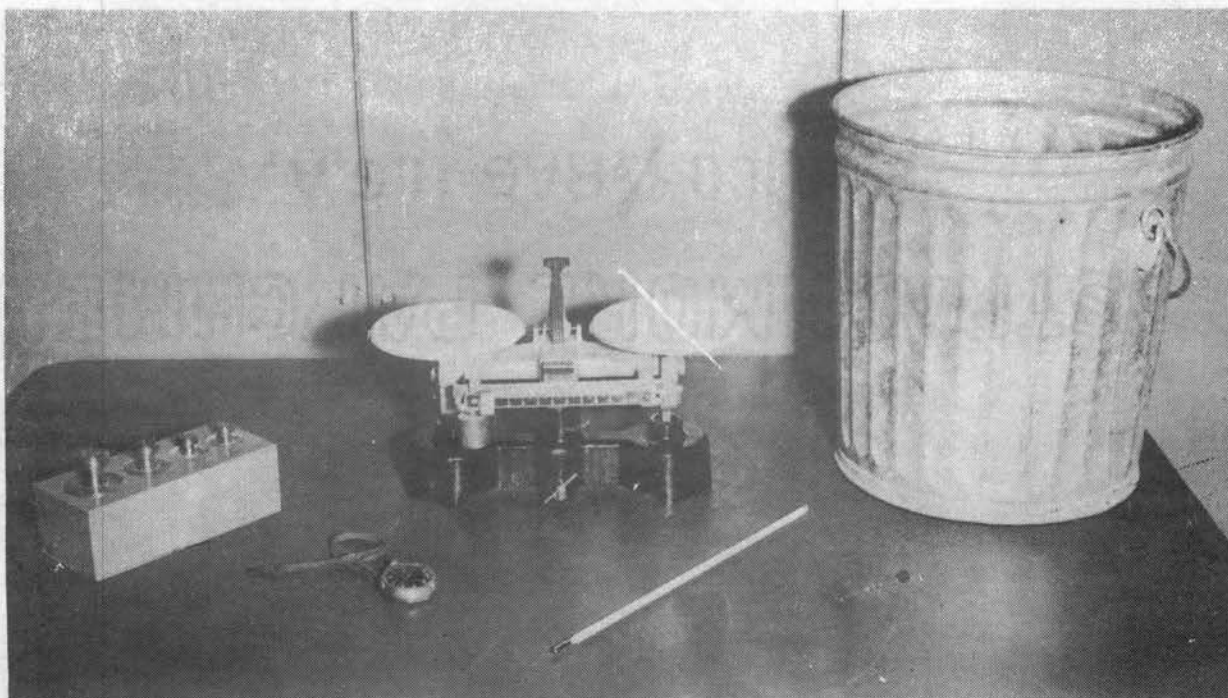

Figure 10. Other Equipment

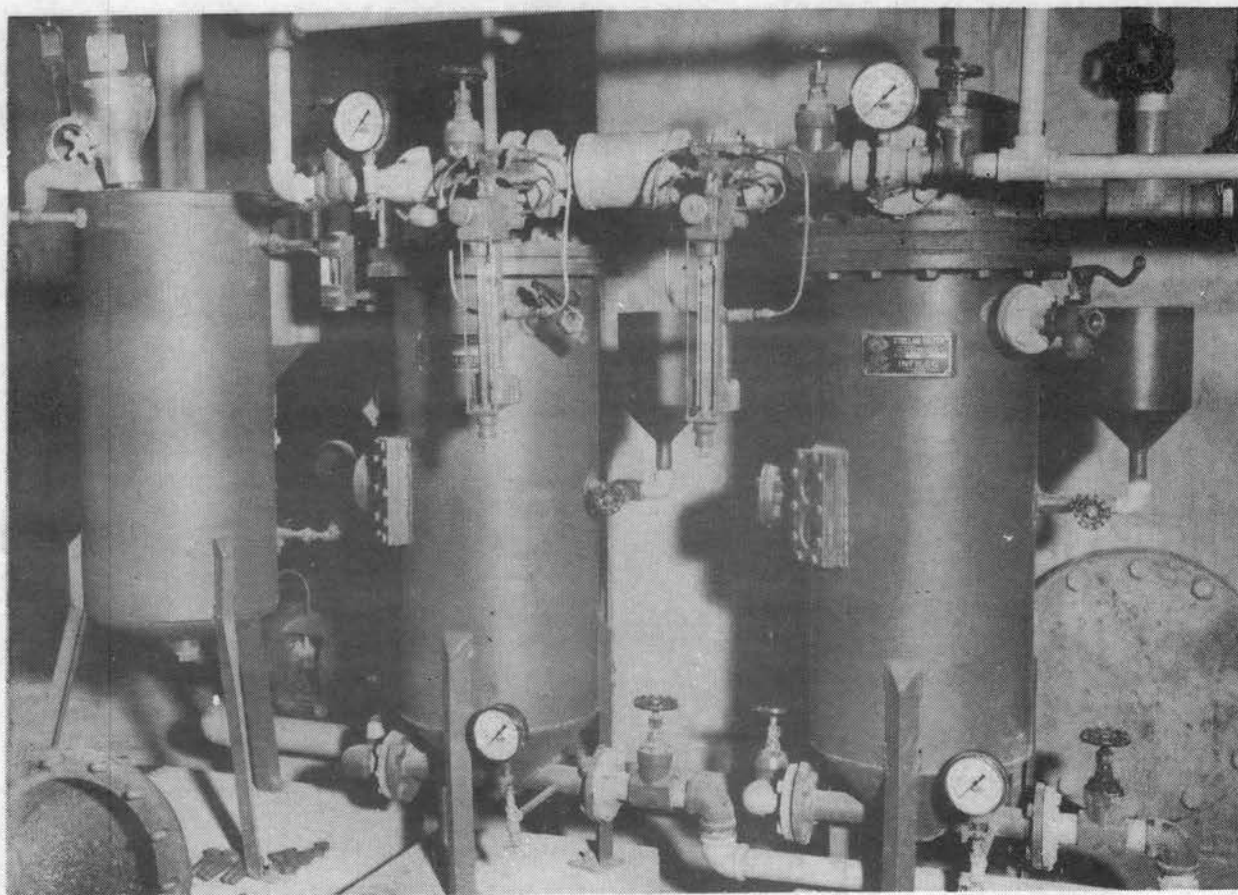

Figure 11. Close View of Control Valves and Gages

## CHAPTER VI

## DESCRIPTION OF DIATOMACEOUS EARTH

Of the more than 10,000 different species of diatoms only the acicular ("needle-like") and elongated types are of general use.<sup>28</sup> In its dry state, even though it has been subjected to the earth's pressures for millions of years, diatomaceous earth weighs only 18 to 30 pounds per cubic foot when quarried. After it is processed, the weight of the same diatomite varies from 7 to 13 pounds per cubic foot. The surface area contained in a pound of diatomite varies between 20,000 and 100,00 square feet.

The chemical composition of these diatoms is almost pure silica ( $\text{SiO}_2$ ) and the physical state is amorphous in character. The feel of this fine powder like mass of fossils is soft to the touch.

Five grades of Celite, diatomite as sold by Johns-Manville Corporation, New York City, New York, were investigated in this study. They range in grade in the following order, the coarsest grade being listed first and the finest grade listed last:

Celite No. 545  
 Celite No. 535  
 Celite No. 501  
 Hyflo Super-Cel  
 Celite No. 512

Cummins<sup>29</sup> provides a means of comparing the relative characteristics of a fine and the coarsest diatomite used in this work. While his experiment used liquid Puerto Rican raw sugar, a parallel comparable to water may still be drawn. His findings were as follows:

| Type            | Filtration Rate | Clarity Factor |
|-----------------|-----------------|----------------|
| Hyflo Super-Cel | 534             | 57.5           |
| Celite 545      | 1830            | 31.6           |

<sup>28</sup> Great Lakes Carbon Corporation, Dicalite Aids to Industry, p. 8.

<sup>29</sup> Cummins, op. cit., p. 407.



Both the filtration rate and clarity factor used the results obtained from Filter-Gel (finest grade sold) as the standard, each having values of 100. Cummins<sup>30</sup> also ascertained the approximate particle size distribution of several filter earths. A graph of these findings as they apply to the coarsest and a fine grade of diatomite used in this paper may be seen in Figure 12.

---

<sup>30</sup> Cummins, op. cit., p. 405.

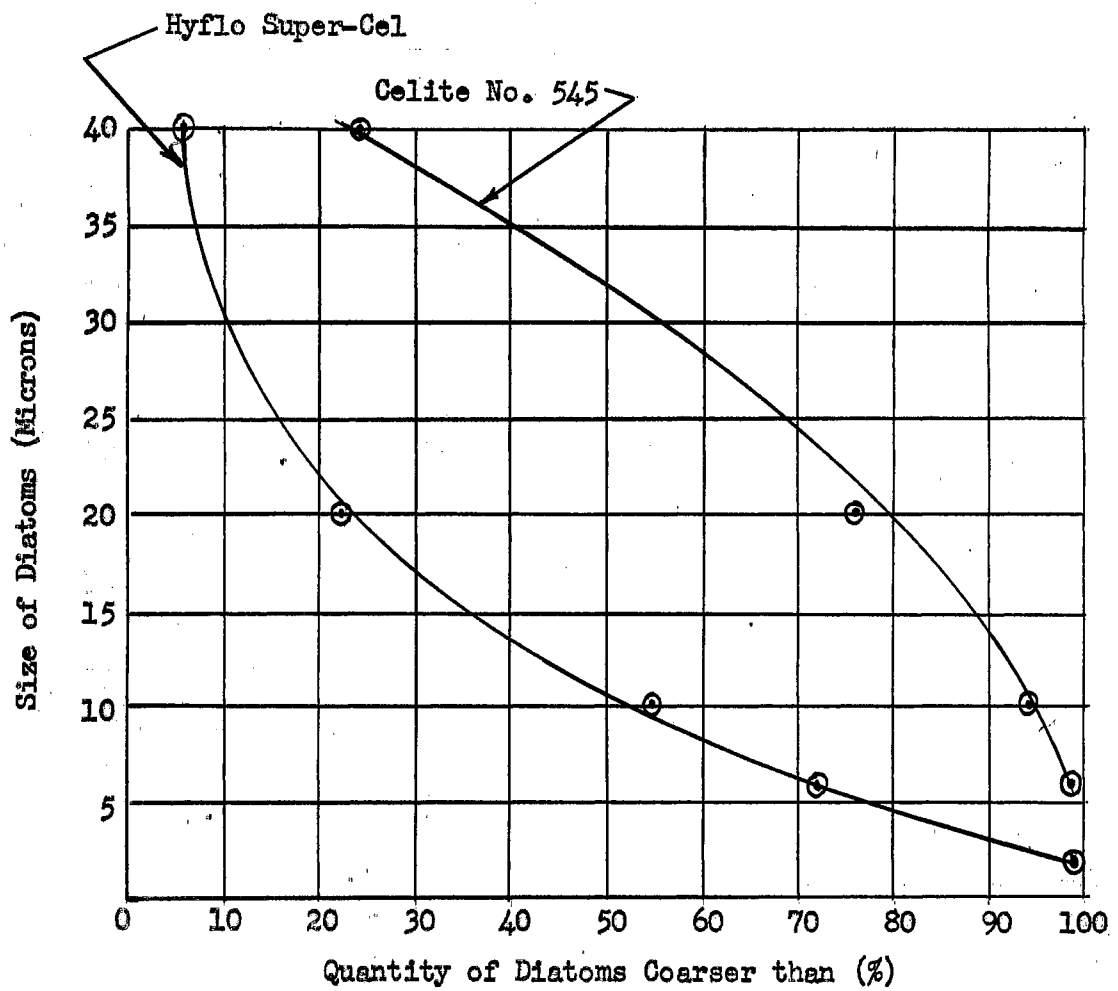

Figure 12. Size Distribution Graph - Comparison of approximate size distribution of particles from two grades of diatomaceous earth.

## CHAPTER VII

## PROCEDURE

The filtration rates were varied in obtaining data, depending upon whether the influent was raw water or coagulated water. The variation in rate was made necessary by the difference in composition of the material causing turbidity in the raw water and the composition of the material causing turbidity in the coagulated water.

When either raw or settled water was to be tested, the desired grade and quantity (charge) of Celite was weighed on the analytical balance. This material was then mixed with a sufficient quantity of water to render it quite fluid, or in other words, put it in a state of suspension. The mixture (slurry) was then ready for charging the elements.

To start the filtering cycle the drain valve was closed and the diatomite-charger valve as well as the filter-to-waste valve was opened. The filter-to-storage valve remained closed. The influent valve controlling flow from pump to filter remained closed as did the valves regulating the rate of flow indicator. The diatomaceous earth slurry was then poured from the mixing container into the diatomite charger. After all the slurry had entered the filter, the diatomite charger was rinsed with clear water and the charger control valve closed. This process is known as charging the filter.

After charging, the centrifugal pump was started and the motor brought to operating speed before the influent valve to the filter was slowly opened. This influent valve was opened until the pressure gage indicated about two to three pounds per square inch of pressure. The charging operation was completed when the precoat had formed on the filter element. This was considered accomplished when the turbidity of the effluent showed a marked decrease. The rate of flow indicators were then actuated. At this point in the cycle, the pro-

cedure followed on the raw water, except in a few tests, differed from that used on settled water. For the vast majority of the raw water tests a constant rate of flow was maintained by slowly adjusting the influent valve to increase the input head as friction loss across the filter increased by the clogging of the interstices with removed turbidity causing materials. The increase in loss due to friction head could then be observed as the discharge rate was held constant.

When the tests on settled water were run, every possible effort was made to obtain the highest possible initial rate of flow. This was best done by first precoating the element with the diatomite to be tested and then opening the influent valve to the fully opened position. The drop in rate of flow could then be observed as the loss of head across the filter increased.

The remainder of the testing procedure was identical for both raw and settled water. During the filtering cycle readings were taken concerning changes in rate of flow, input pressure, output pressure, increases in loss of head and changes in temperature.

The regulating of the effluent discharge rate was always done with the filter-to-storage valve closed and the filter-to-waste valve open. Samples were taken from the effluent water and compared visually with a standard sample containing 5 parts per million of turbidity. When the effluent contained the same turbidity as the standard sample, the filter-to-storage valve was opened and the filter-to-waste valve closed. The length of time required from the end of the precoat period to produce an effluent containing less than five parts per million of turbidity was determined and entered in the data under the term "clear".

At definite regular intervals, depending on the type of water and the anticipated results, samples of both influent water and effluent water were taken and examined with the spectrophotometer to ascertain the amounts of

turbidity. As recommended in the Standard Methods,<sup>31</sup> all turbidities less than one tenth part per million were recorded as one tenth part per million. These influent and effluent samples were also tested from time to time for changes in pH and color. When it was decided that the filter precoat had reached the end of its usefulness, this diatomite coating was removed by bumping.

In bumping the filter, the effluent valve was closed and the pressure in the filter allowed to reach the maximum head of which the pump was capable. The influent valve was then closed and the pump turned off. The quick-opening valve on the side of the filter was then jerked open allowing the resulting pressure differential to dislodge the filter cake from the wires of the filter element. The drain valve was opened and the slurry produced by bumping was drawn off to prepare the filter for another cycle.

The amount of diatomite used on each test was varied within limits that seemed to give additional information. If the rate of flow or turbidity removal was improved as the amount of precoat used was either increased or decreased, the investigation of the grade of diatomite being tested was continued. However, if the results showed no general trend upon which to base further tests, the study of that material was discontinued. To determine if there was a possibility of bumping the filter and redepositing the once used diatomaceous earth for use in the succeeding cycle, it was decided to repeat filter cycles in this manner on several tests. Many tests were run for long periods just to see what characteristics would be evident during long cycles, but because of the rapid build up of head loss and the resulting decrease in rate of flow and often a decrease in percent removal of turbidity, it was believed that the initial sixty minutes of the filter cycle was of prime

---

<sup>31</sup> American Public Health Association, op. cit., p. 14.

importance. Hence, most tests on the coagulated water were discontinued after the initial sixty minute period. Subsequent observations indicated this early assumption to be correct. Cycles on raw water were carried far beyond the point where suitable turbidity removal ended, but it was desired to find out just how the loss of head and rate of flow varied as the cycle continued. It was visioned that under extreme conditions, relaxation of the desired standards might be advantageous. The desirable limits of these relaxations were investigated by noting the additional length of filter run obtainable if the turbidity was allowed to rise somewhat in the effluent. Since the U. S. Public Health Service<sup>32</sup> allows turbidities up to and including ten parts per million, it was considered worthwhile to study flow periods of a duration up to and exceeding the length of time required to produce a water with a turbidity of ten parts per million or less.

The bacteriological tests on both the raw and settled effluent followed Standard Methods.<sup>33</sup> In making plate counts 1 ml samples were planted and in making coliform tests 5-10 ml portions were planted. Influent water samples were obtained from the filter just before the water entered the filter and effluent water samples were taken just after the water left the filter.

It was decided that three different grade-weight combinations of Celite improved the physical quality of water to a degree warranting bacteriological examination. The three combinations tested were:

| <u>Grade</u>    | <u>wt/sq ft of<br/>filter surface</u> | <u>Kind of influent<br/>water</u> |
|-----------------|---------------------------------------|-----------------------------------|
| Hyflo Super-Cel | 0.5 oz                                | Coagulated and Settled            |
| Celite No. 512  | 0.5 oz                                | Coagulated and Settled            |
| Celite No. 512  | 5.33 oz                               | Raw                               |

---

<sup>32</sup> Public Health Reports, April 10, 1925, 693, cited by Babbitt and Doland, op. cit., p. 413.

<sup>33</sup> American Public Health Association, op. cit., pp. 183-208.

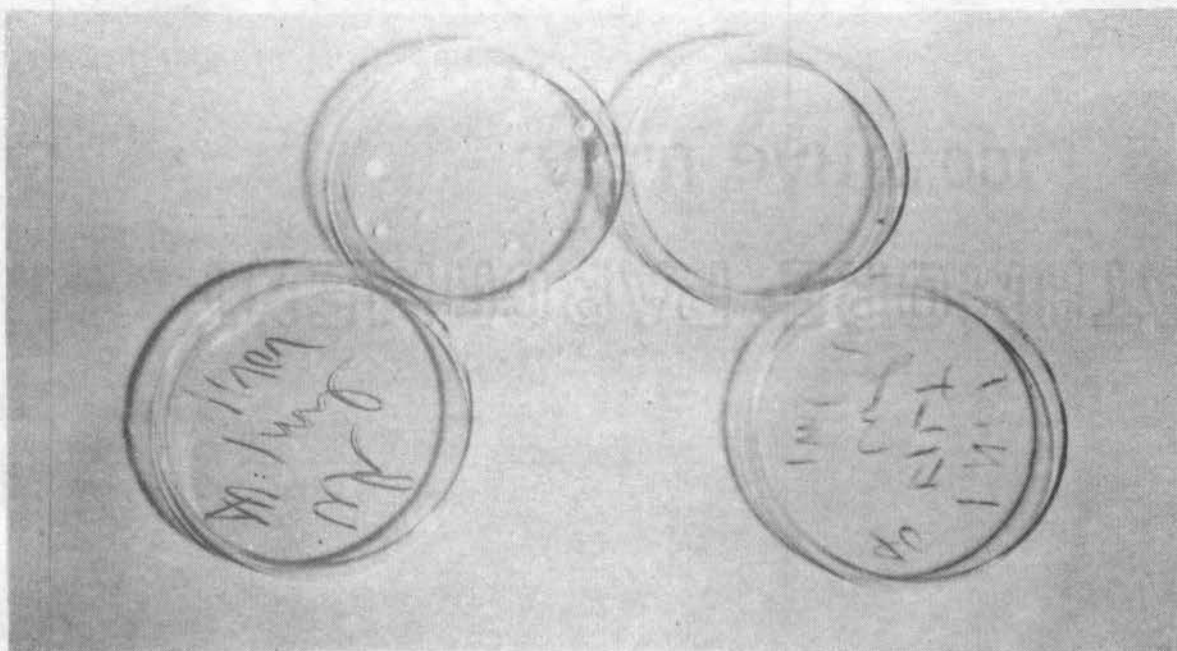

Figure 13. Petri Dishes With and Without Colonies of Bacteria

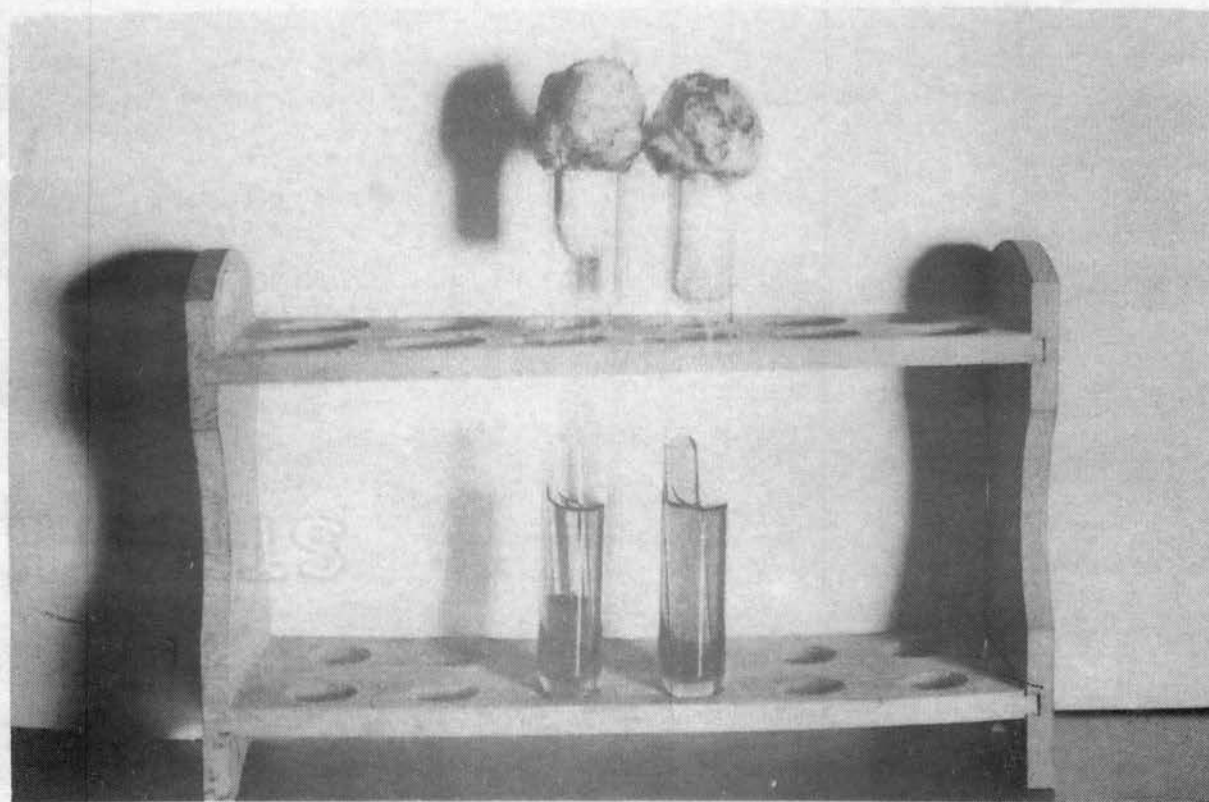

Figure 14. Culture Tubes With and Without Gas Formers

Each grade-weight combination was tested on three cycles. The filter was pre-coated with diatomite and filtration started. A sample was then drawn from the influent water and from the effluent water. The filter was then bumped and drained. On the second cycle, the filter was again pre-coated and filtration allowed to continue for about fifteen minutes before the sample was drawn. Again the filter was bumped and drained. And for the third time the precoat was formed and filtration started, but the sample was not taken this time until after about thirty minutes of filtration. It was believed that this spacing of sampling would give the best results obtainable within the limited scope of this thesis. The data obtained from the above procedure made it possible to study the effectiveness of the diatomaceous earth filter on Lake Carl Blackwell water.



## EXPERIMENTAL DATA

The following data was obtained from tests run between October 23, 1950 and November 30, 1950. The input head, output head and loss of head readings were estimated in the tenths place. The rate was estimated in the units place.

PART I

## Physical Data

Test # 1

|                                  |                                    |
|----------------------------------|------------------------------------|
| Grade - 545                      | pH of influent - not determined    |
| Weight - 1.77 oz/ft <sup>2</sup> | pH of effluent - not determined    |
| Influent - Raw Water             | Color of influent - not determined |
| Temperature of influent - 21°C   | Color of effluent - not determined |
| Turbidity of raw water - 29      | Clear - not determined             |

| Time<br>(min) | Input<br>Head<br>(psi) | Output<br>Head<br>(psi) | Loss<br>Head<br>(psi) | Rate<br>(gpm) | Rate<br>gpm/ft <sup>2</sup> | Turbidity<br>(ppm) |      |
|---------------|------------------------|-------------------------|-----------------------|---------------|-----------------------------|--------------------|------|
|               |                        |                         |                       |               |                             | Inf.               | Eff. |
| 0             | 2.5                    | 2.5                     | 0.0                   | 45            | 5.0                         | 29                 | 25   |
| 60            | 13.0                   | 6.3                     | 6.8                   | 45            | 5.0                         | 29                 | 25   |
| 120           | 38.0                   | 7.5                     | 30.5                  | 45            | 5.0                         | 29                 | 27   |
| 180           | 40.0                   | 7.5                     | 32.5                  | 45            | 5.0                         | 29                 | 28   |

Test # 2

|                                  |                                    |
|----------------------------------|------------------------------------|
| Grade - 545                      | pH of influent - not determined    |
| Weight - 1.77 oz/ft <sup>2</sup> | pH of effluent - not determined    |
| Influent - Raw Water             | Color of influent - not determined |
| Temperature of influent - 21°C   | Color of effluent - not determined |
| Turbidity of raw water - 25      | Clear - not determined             |

| Time<br>(min) | Input<br>Head<br>(psi) | Output<br>Head<br>(psi) | Loss<br>Head<br>(psi) | Rate<br>(gpm) | Rate<br>gpm/ft <sup>2</sup> | Turbidity<br>(ppm) |      |
|---------------|------------------------|-------------------------|-----------------------|---------------|-----------------------------|--------------------|------|
|               |                        |                         |                       |               |                             | Inf.               | Eff. |
| 0             | 2.5                    | 2.5                     | 0.0                   | 45            | 5.0                         | 25                 | 20   |
| 60            | 14.0                   | 7.5                     | 6.5                   | 45            | 5.0                         | 25                 | ---  |
| 120           | 32.0                   | 9.0                     | 23.0                  | 45            | 5.0                         | 25                 | ---  |
| 180           | 55.0                   | 7.5                     | 47.5                  | 37            | 4.1                         | 25                 | ---  |
| 240           | 64.0                   | 6.2                     | 57.8                  | 30            | 3.3                         | 25                 | ---  |
| 300           | 69.0                   | 6.2                     | 62.8                  | 26            | 2.8                         | 25                 | ---  |
| 360           | 70.0                   | 6.2                     | 63.8                  | 23            | 2.5                         | 25                 | ---  |
| 420           | 72.0                   | 6.2                     | 65.8                  | 23            | 2.5                         | 25                 | 23   |

Test # 3

Grade - 545  
 Weight - 2 oz/ft<sup>2</sup>  
 Influent - Raw Water  
 Temperature of Influent - 21°C  
 Turbidity of raw water - 25

pH of influent - not determined  
 pH of effluent - not determined  
 Color of influent - 6  
 Color of effluent - 6  
 Clear - not determined

| Time<br>(min) | Input<br>Head<br>(psi) | Output<br>Head<br>(psi) | Loss<br>Head<br>(psi) | Rate<br>(gpm) | Rate<br>gpm/ft <sup>2</sup> | Turbidity<br>(ppm) |      |
|---------------|------------------------|-------------------------|-----------------------|---------------|-----------------------------|--------------------|------|
|               |                        |                         |                       |               |                             | Inf.               | Eff. |
| 0             | 7.5                    | 7.5                     | 0.0                   | 45            | 5.0                         | 25                 | 15   |
| 60            | 13.0                   | 7.5                     | 5.5                   | 45            | 5.0                         | 25                 | 15   |
| 120           | 25.0                   | 7.5                     | 17.5                  | 45            | 5.0                         | 25                 | 16   |
| 180           | 44.0                   | 7.5                     | 36.5                  | 38            | 4.2                         | 25                 | 16   |
| 240           | 65.0                   | 7.5                     | 57.5                  | 36            | 4.0                         | 25                 | 17   |
| 300           | 68.0                   | 5.0                     | 63.0                  | 26            | 2.9                         | 25                 | 17   |
| 360           | 72.0                   | 5.0                     | 67.0                  | 22            | 2.4                         | 25                 | 18   |

Test # 4

Grade - Hyflo Super-Cel  
 Weight - 1.77 oz/ft<sup>2</sup>  
 Influent - Raw Water  
 Temperature of influent - 21°C  
 Turbidity of raw water - 20

pH of influent - not determined  
 pH of effluent - not determined  
 Color of influent - 5  
 Color of effluent - 5  
 Clear - not determined

| Time<br>(min) | Input<br>Head<br>(psi) | Output<br>Head<br>(psi) | Loss<br>Head<br>(psi) | Rate<br>(gpm) | Rate<br>gpm/ft <sup>2</sup> | Turbidity<br>(ppm) |      |
|---------------|------------------------|-------------------------|-----------------------|---------------|-----------------------------|--------------------|------|
|               |                        |                         |                       |               |                             | Inf.               | Eff. |
| 0             | 7.5                    | 7.5                     | 0.0                   | 45            | 5.0                         | 20                 | 15   |
| 60            | 58.0                   | 7.5                     | 50.5                  | 32            | 3.6                         | 20                 | 15   |
| 120           | 72.0                   | 5.0                     | 67.0                  | 20            | 2.2                         | 20                 | 15   |
| 180           | 74.0                   | 5.0                     | 69.0                  | 17            | 1.9                         | 20                 | 15   |
| 240           | 76.0                   | 5.0                     | 71.0                  | 14            | 1.5                         | 20                 | 15   |
| 300           | 78.0                   | 5.0                     | 73.0                  | 12            | 1.3                         | 20                 | 15   |

Test # 5

Grade - 545  
 Weight - 2.22 oz/ft<sup>2</sup>  
 Influent - Raw Water  
 Temperature of influent - 21°C  
 Turbidity of raw water - 19

pH of influent - not determined  
 pH of effluent - not determined  
 Color of influent - not determined  
 Color of effluent - not determined  
 Clear - not determined

| Time<br>(min)                                | Input<br>Head<br>(psi) | Output<br>Head<br>(psi) | Loss<br>Head<br>(psi) | Rate<br>(gpm) | Rate<br>gpm/ft <sup>2</sup> | Turbidity<br>(ppm) |      |
|--|------------------------|-------------------------|-----------------------|---------------|-----------------------------|--------------------|------|
|  |                        |                         |                       |               |                             | Inf.               | Eff. |
| 0  | 11.0                   | 8.0                     | 3.0                   | 45            | 5.0                         | 19                 | 15   |
| 60   | 48.0                   | 7.0                     | 41.0                  | 35            | 3.9                         | 19                 | 16   |
| 120  | 73.0                   | 6.0                     | 67.0                  | 20            | 2.2                         | 19                 | 17   |
| 180  | 76.0                   | 5.5                     | 70.5                  | 16            | 1.8                         | 19                 | 19   |
| 240  | 78.0                   | 5.0                     | 73.0                  | 12            | 1.3                         | 19                 | 19   |
| Filter bumped and same diatomite redeposited |                        |                         |                       |               |                             |                    |      |
| 0  | 34.0                   | 8.0                     | 26.0                  | 41            | 4.5                         | 19                 | 17   |
| 30   | 60.0                   | 7.0                     | 53.0                  | 30            | 3.3                         | 19                 | 17   |
| 60   | 70.0                   | 6.0                     | 64.0                  | 22            | 2.4                         | 19                 | 17   |
| 90   | 75.0                   | 5.0                     | 70.0                  | 16            | 1.8                         | 19                 | 17   |
| 120  | 78.0                   | 5.0                     | 73.0                  | 14            | 1.5                         | 19                 | 17   |
| 150  | 79.0                   | 5.0                     | 74.0                  | 12            | 1.3                         | 19                 | 17   |

Test # 5A

Grade - 545  
 Weight - 1.77 oz/ft<sup>2</sup>  
 Influent - Raw Water  
 Temperature of influent - 21°C  
 Turbidity of raw water - 19

pH of influent - not determined  
 pH of effluent - not determined  
 Color of influent - not determined  
 Color of effluent - not determined  
 Clear - not determined

| Time<br>(min) | Input<br>Head<br>(psi) | Output<br>Head<br>(psi) | Loss<br>Head<br>(psi) | Rate<br>(gpm) | Rate<br>gpm/ft <sup>2</sup> | Turbidity<br>(ppm) |      |
|---------------|------------------------|-------------------------|-----------------------|---------------|-----------------------------|--------------------|------|
|               |                        |                         |                       |               |                             | Inf.               | Eff. |
| 0             | 70.0                   | 68.0                    | 2.0                   | 27            | 3.0                         | 19                 | 14   |
| 60            | 68.0                   | 64.0                    | 4.0                   | 27            | 3.0                         | 19                 | 16   |
| 120           | 68.0                   | 48.0                    | 20.0                  | 27            | 3.0                         | 19                 | ---  |
| 180           | 69.0                   | 24.0                    | 45.0                  | 27            | 3.0                         | 19                 | ---  |
| 240           | 66.0                   | 7.0                     | 59.0                  | 27            | 3.0                         | 19                 | ---  |
| 300           | 73.0                   | 6.0                     | 67.0                  | 20            | 2.2                         | 19                 | 18   |

Test # 6

Grade - 50l  
 Weight - 1.77 oz/ft<sup>2</sup>  
 Influent - Raw Water  
 Temperature of influent - 20°C  
 Turbidity of raw water - 20

pH of influent - not determined  
 pH of effluent - not determined  
 Color of influent - 5  
 Color of effluent - 5  
 Clear - not determined

| Time<br>(min) | Input<br>Head<br>(psi) | Output<br>Head<br>(psi) | Loss<br>Head<br>(psi) | Rate<br>(gpm) | Rate<br>gpm/ft <sup>2</sup> | Turbidity<br>(ppm) |      |
|---------------|------------------------|-------------------------|-----------------------|---------------|-----------------------------|--------------------|------|
|               |                        |                         |                       |               |                             | Inf.               | Eff. |
| 0             | 71.0                   | 63.0                    | 8.0                   | 27            | 3.0                         | 20                 | 11   |
| 60            | 73.0                   | 50.0                    | 23.0                  | 27            | 3.0                         | 20                 | 12   |
| 120           | 72.5                   | 7.5                     | 65.0                  | 27            | 3.0                         | 20                 | 14   |
| 180           | 80.0                   | 5.0                     | 75.0                  | 22            | 2.4                         | 20                 | 14   |
| 210           | 82.0                   | 5.0                     | 77.0                  | 12            | 1.3                         | 20                 | 14   |

Test # 7

Grade - 50l  
 Weight - 3.55 oz/ft<sup>2</sup>  
 Influent - Raw Water  
 Temperature of influent - 20°C  
 Turbidity of raw water - 20

pH of influent - not determined  
 pH of effluent - not determined  
 Color of influent - not determined  
 Color of effluent - not determined  
 Clear - 45 seconds

| Time<br>(min) | Input<br>Head<br>(psi) | Output<br>Head<br>(psi) | Loss<br>Head<br>(psi) | Rate<br>(gpm) | Rate<br>gpm/ft <sup>2</sup> | Turbidity<br>(ppm) |      |
|---------------|------------------------|-------------------------|-----------------------|---------------|-----------------------------|--------------------|------|
|               |                        |                         |                       |               |                             | Inf.               | Eff. |
| 0             | 80.0                   | 75.0                    | 5.0                   | 18            | 2.0                         | 20                 | 6    |
| 30            | 80.0                   | 71.0                    | 9.0                   | 18            | 2.0                         | 20                 | 6    |
| 60            | 80.0                   | 65.0                    | 15.0                  | 18            | 2.0                         | 20                 | 6    |
| 90            | 80.0                   | 59.0                    | 21.0                  | 18            | 2.0                         | 20                 | 6    |
| 120           | 80.0                   | 48.0                    | 32.0                  | 18            | 2.0                         | 20                 | 7    |
| 150           | 80.0                   | 40.0                    | 40.0                  | 18            | 2.0                         | 20                 | 7    |
| 180           | 80.0                   | 22.0                    | 58.0                  | 18            | 2.0                         | 20                 | 8    |
| 210           | 80.0                   | 16.0                    | 64.0                  | 18            | 2.0                         | 20                 | 9    |
| 240           | 79.0                   | 5.0                     | 74.0                  | 18            | 2.0                         | 20                 | 13   |
| 270           | 79.0                   | 5.0                     | 74.0                  | 18            | 2.0                         | 20                 | 14   |
| 300           | 79.0                   | 5.0                     | 74.0                  | 18            | 2.0                         | 20                 | 15   |
| 330           | 79.0                   | 5.0                     | 74.0                  | 18            | 2.0                         | 20                 | 18   |

Test # 8

Grade - 501  
 Weight - 3.55 oz/ft<sup>2</sup>  
 Influent - Raw Water  
 Temperature of influent - 19°C  
 Turbidity of raw water - 22

pH of influent - 8.3  
 pH of effluent - 8.3  
 Color of influent - not determined  
 Color of effluent - not determined  
 Clear - not determined

| Time<br>(min) | Input<br>Head<br>(psi) | Output<br>Head<br>(psi) | Loss<br>Head<br>(psi) | Rate<br>(gpm) | Rate<br>gpm/ft <sup>2</sup> | Turbidity<br>(ppm) |      |
|---------------|------------------------|-------------------------|-----------------------|---------------|-----------------------------|--------------------|------|
|               |                        |                         |                       |               |                             | Inf.               | Eff. |
| 0             | 84.0                   | 78.0                    | 6.0                   | 18            | 2.0                         | 22                 | 8    |
| 30            | 84.0                   | 73.0                    | 11.0                  | 18            | 2.0                         | 22                 | 8    |
| 60            | 84.0                   | 63.0                    | 21.0                  | 18            | 2.0                         | 22                 | 8    |
| 90            | 84.0                   | 38.0                    | 46.0                  | 18            | 2.0                         | 22                 | 9    |
| 120           | 84.0                   | 22.0                    | 62.0                  | 18            | 2.0                         | 22                 | 10   |
| 150           | 84.0                   | 20.0                    | 64.0                  | 18            | 2.0                         | 22                 | 18   |
| 180           | 82.0                   | 10.0                    | 72.0                  | 18            | 2.0                         | 22                 | 20   |
| 210           | 82.0                   | 9.0                     | 73.0                  | 18            | 2.0                         | 22                 | 20   |
| 240           | 83.0                   | 10.0                    | 73.0                  | 18            | 2.0                         | 22                 | 21   |

Test # 9

Grade - 501  
 Weight - 5 oz/ft<sup>2</sup>  
 Influent - Raw Water  
 Temperature of influent - 19°C  
 Turbidity of raw water - 20

pH of influent - not determined  
 pH of effluent - not determined  
 Color of influent - not determined  
 Color of effluent - not determined  
 Clear - not determined

| Time<br>(min)                                | Input<br>Head<br>(psi) | Output<br>Head<br>(psi) | Loss<br>Head<br>(psi) | Rate<br>(gpm) | Rate<br>gpm/ft <sup>2</sup> | Turbidity<br>(ppm) |      |
|--|------------------------|-------------------------|-----------------------|---------------|-----------------------------|--------------------|------|
|  |                        |                         |                       |               |                             | Inf.               | Eff. |
| 0  | 83.0                   | 80.0                    | 3.0                   | 18            | 2.0                         | 20                 | 6    |
| 30   | 83.0                   | 78.0                    | 5.0                   | 18            | 2.0                         | 20                 | 7    |
| 60   | 83.0                   | 65.0                    | 18.0                  | 18            | 2.0                         | 20                 | 8    |
| 90   | 83.0                   | 52.0                    | 31.0                  | 18            | 2.0                         | 20                 | 8    |
| 120  | 83.0                   | 32.0                    | 51.0                  | 18            | 2.0                         | 20                 | 9    |
| 150  | 83.0                   | 14.0                    | 69.0                  | 18            | 2.0                         | 20                 | 11   |
| 180  | 83.0                   | 11.0                    | 72.0                  | 18            | 2.0                         | 20                 | 12   |
| 210  | 83.0                   | 9.0                     | 74.0                  | 18            | 2.0                         | 20                 | 13   |
| 225  | 83.0                   | 7.0                     | 76.0                  | 18            | 2.0                         | 20                 | 15   |
| 240  | 83.0                   | 6.0                     | 77.0                  | 18            | 2.0                         | 20                 | 16   |
| 270  | 83.0                   | 5.0                     | 78.0                  | 17            | 1.9                         | 20                 | 17   |
| 300  | 83.0                   | 4.0                     | 79.0                  | 15            | 1.7                         | 20                 | 18   |
| 330  | 83.0                   | 4.0                     | 79.0                  | 15            | 1.7                         | 20                 | 18   |
| Filter bumped and same diatomite redeposited |                        |                         |                       |               |                             |                    |      |
| 0  | 83.0                   | 67.0                    | 16.0                  | 18            | 2.0                         | 20                 | 8    |
| 30   | 83.0                   | 61.0                    | 22.0                  | 18            | 2.0                         | 20                 | 8    |
| 60   | 83.0                   | 44.0                    | 39.0                  | 18            | 2.0                         | 20                 | 9    |
| 90   | 83.0                   | 22.0                    | 61.0                  | 18            | 2.0                         | 20                 | 10   |
| 120  | 83.0                   | 9.0                     | 74.0                  | 18            | 2.0                         | 20                 | 10   |
| 135  | 83.0                   | 6.0                     | 77.0                  | 18            | 2.0                         | 20                 | 12   |
| 150  | 83.0                   | 6.0                     | 77.0                  | 18            | 2.0                         | 20                 | 15   |
| 180  | 83.0                   | 6.0                     | 77.0                  | 18            | 2.0                         | 20                 | 17   |
| 210  | 83.0                   | 6.0                     | 77.0                  | 18            | 2.0                         | 20                 | 19   |

Test # 10

Grade - Hyflo Super-Cel  
 Weight - 4.44 oz/ft<sup>2</sup>  
 Influent - Raw Water  
 Temperature of influent - 19°C  
 Turbidity of raw water - 24

pH of influent - 8.3  
 pH of effluent - 8.3  
 Color of influent - not determined  
 Color of effluent - not determined  
 Clear - 60 seconds

| Time<br>(min)                                | Input<br>Head<br>(psi) | Output<br>Head<br>(psi) | Loss<br>Head<br>(psi) | Rate<br>(gpm) | Rate<br>gpm/ft <sup>2</sup> | Turbidity<br>(ppm) |      |
|--|------------------------|-------------------------|-----------------------|---------------|-----------------------------|--------------------|------|
|  |                        |                         |                       |               |                             | Inf.               | Eff. |
| 0  | 82.0                   | 72.0                    | 10.0                  | 18            | 2.0                         | 24                 | 4    |
| 60   | 82.0                   | 22.0                    | 60.0                  | 18            | 2.0                         | 24                 | 5    |
| 90   | 82.0                   | 5.0                     | 77.0                  | 15            | 1.6                         | 24                 | 8    |
| 105  | 82.0                   | 4.0                     | 78.0                  | 11            | 1.2                         | 24                 | 9    |
| Filter bumped and same diatomite redeposited |                        |                         |                       |               |                             |                    |      |
| 0  | 80.0                   | 53.0                    | 27.0                  | 18            | 2.0                         | 24                 | 5    |
| 60   | 80.0                   | 6.0                     | 74.0                  | 16            | 1.8                         | 24                 | 8    |
| 90   | 80.0                   | 1.0                     | 79.0                  | 10            | 1.1                         | 24                 | 10   |

Test # 11

It was discovered that the filter element was improperly precoated so this test was discontinued.

Test # 12

Grade - 535  
 Weight - 5 oz/ft<sup>2</sup>  
 Influent - Raw Water  
 Temperature of influent - 19°C  
 Turbidity of raw water - 23

pH of influent - 8.3  
 pH of effluent - 8.3  
 Color of influent - not determined  
 Color of effluent - not determined  
 Clear - 20 seconds

| Time<br>(min) | Input<br>Head<br>(psi) | Output<br>Head<br>(psi) | Loss<br>Head<br>(psi) | Rate<br>(gpm) | Rate<br>gpm/ft <sup>2</sup> | Turbidity<br>(ppm) |      |
|---------------|------------------------|-------------------------|-----------------------|---------------|-----------------------------|--------------------|------|
|               |                        |                         |                       |               |                             | Inf.               | Eff. |
| 0             | 80.0                   | 74.0                    | 6.0                   | 18            | 2.0                         | 23                 | 7    |
| 60            | 84.5                   | 10.0                    | 74.0                  | 11            | 1.2                         | 23                 | 8    |
| 120           | 85.0                   | 7.5                     | 77.5                  | 2             | 0.2                         | 23                 | 11   |

Test # 13

Grade - 512  
 Weight - 5.33 oz/ft<sup>2</sup>  
 Influent - Raw Water  
 Temperature of influent - 18°C  
 Turbidity of raw water - 25

pH of influent - not determined  
 pH of effluent - not determined  
 Color of influent - 5  
 Color of effluent - 5  
 Clear - 40 seconds

| <u>Time (min)</u>                            | <u>Input Head (psi)</u> | <u>Output Head (psi)</u> | <u>Loss Head (psi)</u> | <u>Rate (gpm)</u> | <u>Rate gpm/ft<sup>2</sup></u> | <u>Turbidity (ppm)</u> |             |
|--|-------------------------|--------------------------|------------------------|-------------------|--------------------------------|------------------------|-------------|
|  |                         |                          |                        |                   |                                | <u>Inf.</u>            | <u>Eff.</u> |
| 0  | 81.0                    | 68.0                     | 13.0                   | 18                | 2.0                            | 25                     | 3           |
| 30   | 83.5                    | 27.5                     | 56.0                   | 12                | 2.0                            | 25                     | 4           |
| 60   | 85.0                    | 12.0                     | 73.0                   | 5                 | 0.5                            | 25                     | 12          |
| 90   | 85.0                    | 10.0                     | 75.0                   | 1                 | 0.1                            | 25                     | 17          |
| Filter bumped and same diatomite redeposited |                         |                          |                        |                   |                                |                        |             |
| 0  | 82.0                    | 58.0                     | 24.0                   | 18                | 2.0                            | 25                     | 4           |
| 30   | 82.0                    | 7.5                      | 74.5                   | 18                | 2.0                            | 25                     | 6           |
| 45   | 82.0                    | 3.0                      | 79.0                   | 10                | 1.1                            | 25                     | 6           |

Test # 14

Grade - Hyflo Super-Cel  
 Weight - 5.33 oz/ft<sup>2</sup>  
 Influent - Raw Water  
 Temperature of influent - 18°C  
 Turbidity of raw water - 24

pH of influent - not determined  
 pH of effluent - not determined  
 Color of influent - 5  
 Color of effluent - 5  
 Clear - 40 seconds

| <u>Time (min)</u> | <u>Input Head (psi)</u> | <u>Output Head (psi)</u> | <u>Loss Head (psi)</u> | <u>Rate (gpm)</u> | <u>Rate gpm/ft<sup>2</sup></u> | <u>Turbidity (ppm)</u> |             |
|-------------------|-------------------------|--------------------------|------------------------|-------------------|--------------------------------|------------------------|-------------|
|                   |                         |                          |                        |                   |                                | <u>Inf.</u>            | <u>Eff.</u> |
| 0                 | 81.0                    | 74.0                     | 7.0                    | 18                | 2.0                            | 24                     | 5           |
| 30                | 81.0                    | 63.0                     | 18.0                   | 18                | 2.0                            | 24                     | 5           |
| 60                | 81.0                    | 19.0                     | 62.0                   | 18                | 2.0                            | 24                     | 6           |
| 75                | 81.0                    | 5.0                      | 76.0                   | 16                | 1.8                            | 24                     | 6           |

Test # 15

Grade - 512  
 Weight - 5.33 oz/ft<sup>2</sup>  
 Influent - Raw Water  
 Temperature of influent - 17.5°C  
 Turbidity of raw water - 23

pH of influent - not determined  
 pH of effluent - not determined  
 Color of influent - not determined  
 Color of effluent - not determined  
 Clear - 52 seconds

| Time<br>(min)                                | Input<br>Head<br>(psi) | Output<br>Head<br>(psi) | Loss<br>Head<br>(psi) | Rate<br>(gpm) | Rate<br>gpm/ft <sup>2</sup> | Turbidity<br>(ppm) |      |
|--|------------------------|-------------------------|-----------------------|---------------|-----------------------------|--------------------|------|
|  |                        |                         |                       |               |                             | Inf.               | Eff. |
| 0  | 81.0                   | 67.0                    | 14.0                  | 18            | 2.0                         | 23                 | 3    |
| 30   | 81.0                   | 30.0                    | 51.0                  | 18            | 2.0                         | 23                 | 3    |
| 60   | 81.0                   | 1.0                     | 80.0                  | 10            | 1.1                         | 23                 | 8    |
| Filter bumped and same diatomite redeposited |                        |                         |                       |               |                             |                    |      |
| 0  | 82.0                   | 65.0                    | 17.0                  | 18            | 2.0                         | 23                 | 4    |
| 30   | 82.0                   | 20.0                    | 42.0                  | 18            | 2.0                         | 23                 | 5    |
| 45   | 82.0                   | 5.0                     | 77.0                  | 11            | 1.2                         | 23                 | 8    |

Test # 16

Grade - Hyflo Super-Gel  
 Weight - 5.33 oz/ft<sup>2</sup>  
 Influent - Raw Water  
 Temperature of influent - 17.5°C  
 Turbidity of raw water - 67

pH of influent - not determined  
 pH of effluent - not determined  
 Color of influent - not determined  
 Color of effluent - not determined  
 Clear - 38 seconds

| Time<br>(min)                                | Input<br>Head<br>(psi) | Output<br>Head<br>(psi) | Loss<br>Head<br>(psi) | Rate<br>(gpm) | Rate<br>gpm/ft <sup>2</sup> | Turbidity<br>(ppm) |      |
|--|------------------------|-------------------------|-----------------------|---------------|-----------------------------|--------------------|------|
|  |                        |                         |                       |               |                             | Inf.               | Eff. |
| 0  | 82.0                   | 46.0                    | 36.0                  | 18            | 2.0                         | 67                 | 9    |
| 15   | 82.0                   | 1.0                     | 81.0                  | 5             | 0.5                         | 67                 | 9    |
| Filter bumped and same diatomite redeposited |                        |                         |                       |               |                             |                    |      |
| 0  | 82.0                   | 42.0                    | 40.0                  | 18            | 2.0                         | 67                 | 11   |
| 5  | 82.0                   | 5.0                     | 77.0                  | 15            | 1.7                         | 67                 | 15   |
| 10   | 82.0                   | 2.0                     | 80.0                  | 5             | 0.5                         | 67                 | 23   |



Test # 17

Grade - 545  
 Weight - 5.33 oz/ft<sup>2</sup>  
 Influent - Raw Water  
 Temperature of influent - 17.5°C  
 Turbidity of raw water - 51

pH of influent - not determined  
 pH of effluent - not determined  
 Color of influent - not determined  
 Color of effluent - not determined  
 Clear - 82 seconds

| Time<br>(min)                                | Input<br>Head<br>(psi) | Output<br>Head<br>(psi) | Loss<br>Head<br>(psi) | Rate<br>(gpm) | Rate<br>gpm/ft <sup>2</sup> | Turbidity<br>(ppm) |      |
|--|------------------------|-------------------------|-----------------------|---------------|-----------------------------|--------------------|------|
|  |                        |                         |                       |               |                             | Inf.               | Eff. |
| 0  | 82.0                   | 74.0                    | 8.0                   | 18            | 2.0                         | 51                 | 21   |
| 15   | 82.0                   | 5.0                     | 77.0                  | 15            | 1.7                         | 51                 | 25   |
| 30   | 82.0                   | 3.0                     | 79.0                  | 10            | 1.1                         | 51                 | 29   |
| Filter bumped and same diatomite redeposited |                        |                         |                       |               |                             |                    |      |
| 0  | 82.0                   | 56.0                    | 32.0                  | 18            | 2.0                         | 51                 | 24   |
| 15   | 82.0                   | 5.0                     | 77.0                  | 12            | 1.3                         | 51                 | 29   |
| 30   | 82.0                   | 1.0                     | 81.0                  | 9             | 1.0                         | 51                 | 38   |

Test # 18

Grade - 501  
 Weight - 5.33 oz/ft<sup>2</sup>  
 Influent - Raw Water  
 Temperature of influent - 17.5°C  
 Turbidity of raw water - 24

pH of influent - not determined  
 pH of effluent - not determined  
 Color of influent - not determined  
 Color of effluent - not determined  
 Clear - 90 seconds

| Time<br>(min) | Input<br>Head<br>(psi) | Output<br>Head<br>(psi) | Loss<br>Head<br>(psi) | Rate<br>(gpm) | Rate<br>gpm/ft <sup>2</sup> | Turbidity<br>(ppm) |      |
|---------------|------------------------|-------------------------|-----------------------|---------------|-----------------------------|--------------------|------|
|               |                        |                         |                       |               |                             | Inf.               | Eff. |
| 0             | 82.0                   | 70.0                    | 12                    | 18            | 2.0                         | 24                 | 6    |
| 30            | 82.0                   | 64.0                    | 18                    | 18            | 2.0                         | 24                 | 7    |
| 60            | 82.0                   | 46.0                    | 36                    | 18            | 2.0                         | 24                 | 8    |
| 90            | 82.0                   | 23.0                    | 59                    | 18            | 2.0                         | 24                 | 9    |
| 120           | 82.0                   | 5.0                     | 77                    | 15            | 1.7                         | 24                 | 12   |
| 135           | 82.0                   | 3.0                     | 79                    | 14            | 1.5                         | 24                 | 14   |

Test # 19

Grade - 512  
 Weight - 5.33 oz/ft<sup>2</sup>  
 Influent - Raw Water  
 Temperature of influent - 16°C  
 Turbidity of raw water - 24

pH of influent - 8.  
 pH of effluent - 8.  
 Color of influent - not determined  
 Color of effluent - not determined  
 Clear - 95 seconds

| Time<br>(min)                                | Input<br>Head<br>(psi) | Output<br>Head<br>(psi) | Loss<br>Head<br>(psi) | Rate<br>(gpm) | Rate<br>gpm/ft <sup>2</sup> | Turbidity<br>(ppm) |      |
|--|------------------------|-------------------------|-----------------------|---------------|-----------------------------|--------------------|------|
|  |                        |                         |                       |               |                             | Inf.               | Eff. |
| 0  | 82.0                   | 66.0                    | 16.0                  | 18            | 2.0                         | 24                 | 3    |
| 30   | 82.0                   | 32.0                    | 50.0                  | 18            | 2.0                         | 24                 | 4    |
| 60   | 82.0                   | 4.0                     | 78.0                  | 15            | 1.7                         | 24                 | 14   |
| 90   | 82.0                   | 3.0                     | 79.0                  | 10            | 1.1                         | 24                 | 18   |
| 120  | 82.0                   | 2.0                     | 80.0                  | 8             | 0.9                         | 24                 | 20   |
| Filter bumped and same diatomite redeposited |                        |                         |                       |               |                             |                    |      |
| 0  | 83.0                   | 51.0                    | 32.0                  | 18            | 2.0                         | 23                 | 13   |
| 30   | 83.0                   | 13.0                    | 70.0                  | 18            | 2.0                         | 23                 | 13   |
| 45   | 83.0                   | 5.5                     | 77.5                  | 17            | 1.9                         | 23                 | 15   |
| 60   | 83.0                   | 5.0                     | 78.0                  | 15            | 1.7                         | 23                 | 16   |
| 90   | 83.0                   | 3.0                     | 80.0                  | 15            | 1.7                         | 23                 | 19   |
| 120  | 83.0                   | 3.0                     | 80.0                  | 15            | 1.7                         | 23                 | 20   |
| 135  | 83.0                   | 3.0                     | 80.0                  | 4             | 0.4                         | 23                 | 21   |
| Filter bumped and same diatomite redeposited |                        |                         |                       |               |                             |                    |      |
| 0  | 83.0                   | 45.0                    | 38.0                  | 18            | 2.0                         | 22                 | 16   |
| 30   | 83.0                   | 10.0                    | 73.0                  | 18            | 2.0                         | 22                 | 17   |

Test # 20

Grade - 535  
 Weight - 5.33 oz/ft<sup>2</sup>  
 Influent - Raw Water  
 Temperature of influent - 15°C  
 Turbidity of raw water - 22

pH of influent - not determined  
 pH of effluent - not determined  
 Color of influent - 5  
 Color of effluent - 5  
 Clear - 96 seconds

| Time<br>(min)                                | Input<br>Head<br>(psi) | Output<br>Head<br>(psi) | Loss<br>Head<br>(psi) | Rate<br>(gpm) | Rate<br>gpm/ft <sup>2</sup> | Turbidity<br>(ppm) |      |
|--|------------------------|-------------------------|-----------------------|---------------|-----------------------------|--------------------|------|
|  |                        |                         |                       |               |                             | Inf.               | Eff. |
| 0  | 82.0                   | 72.0                    | 10.0                  | 18            | 2.0                         | 22                 | 6    |
| 30   | 82.0                   | 67.0                    | 15.0                  | 18            | 2.0                         | 22                 | 7    |
| 60   | 82.0                   | 47.0                    | 35.0                  | 18            | 2.0                         | 22                 | 10   |
| 90   | 82.0                   | 12.0                    | 70.0                  | 18            | 2.0                         | 22                 | 13   |
| 120  | 82.0                   | 7.5                     | 74.5                  | 15            | 1.7                         | 22                 | 17   |
| 150  | 82.0                   | 4.0                     | 78.0                  | 14            | 1.5                         | 22                 | 19   |
| Filter bumped and same diatomite redeposited |                        |                         |                       |               |                             |                    |      |
| 0  | 77.0                   | 23.0                    | 54.0                  | 18            | 2.0                         | 22                 | 13   |
| 30   | 78.0                   | 15.0                    | 63.0                  | 18            | 2.0                         | 22                 | 15   |
| 45   | 78.0                   | 7.5                     | 70.5                  | 18            | 2.0                         | 22                 | 16   |

Test # 21

Grade - Hyflo Super-Cel  
 Weight - 5.33 oz/ft<sup>2</sup>  
 Influent - Raw Water  
 Temperature of influent - 15°C  
 Turbidity of raw water - 23

pH of influent - not determined  
 pH of effluent - not determined  
 Color of influent - not determined  
 Color of effluent - not determined  
 Clear - not determined

| Time<br>(min) | Input<br>Head<br>(psi) | Output<br>Head<br>(psi) | Loss<br>Head<br>(psi) | Rate<br>(gpm) | Rate<br>gpm/ft <sup>2</sup> | Turbidity<br>(ppm) |      |
|---------------|------------------------|-------------------------|-----------------------|---------------|-----------------------------|--------------------|------|
|               |                        |                         |                       |               |                             | Inf.               | Eff. |
| 0             | 81.0                   | 74.0                    | 7.0                   | 18            | 2.0                         | 23                 | 6    |
| 30            | 81.0                   | 63.0                    | 18.0                  | 18            | 2.0                         | 23                 | 6    |
| 60            | 81.0                   | 42.0                    | 39.0                  | 18            | 2.0                         | 23                 | 7    |
| 90            | 81.0                   | 21.0                    | 60.0                  | 18            | 2.0                         | 23                 | 12   |
| 120           | 81.0                   | 10.0                    | 71.0                  | 18            | 2.0                         | 23                 | 14   |
| 150           | 81.0                   | 4.0                     | 77.0                  | 17            | 1.9                         | 23                 | 15   |
| 165           | 81.0                   | 3.0                     | 78.0                  | 16            | 1.8                         | ---                | ---  |

Test # 22

Grade - 512  
 Weight - 7.11 oz/ft<sup>2</sup>  
 Influent - Raw Water  
 Temperature of influent - 16°C  
 Turbidity of raw water - 23

pH of influent - not determined  
 pH of effluent - not determined  
 Color of influent - not determined  
 Color of effluent - not determined  
 Clear - 120 seconds

| Time<br>(min)                                | Input<br>Head<br>(psi) | Output<br>Head<br>(psi) | Loss<br>Head<br>(psi) | Rate<br>(gpm) | Rate<br>gpm/ft <sup>2</sup> | Turbidity<br>(ppm) |      |
|--|------------------------|-------------------------|-----------------------|---------------|-----------------------------|--------------------|------|
|  |                        |                         |                       |               |                             | Inf.               | Eff. |
| 0  | 79.0                   | 57.0                    | 22.0                  | 18            | 2.0                         | 23                 | 3    |
| 15   | 79.0                   | 41.0                    | 38.0                  | 18            | 2.0                         | 23                 | 3    |
| 30   | 79.0                   | 22.0                    | 57.0                  | 18            | 2.0                         | 23                 | 6    |
| 45   | 79.0                   | 5.0                     | 74.0                  | 18            | 2.0                         | 23                 | 13   |
| 60   | 79.0                   | 4.0                     | 75.0                  | 16            | 1.8                         | 23                 | 15   |
| 75   | 79.0                   | 3.5                     | 75.5                  | 15            | 1.7                         | 23                 | 16   |
| Filter bumped and same diatomite redeposited |                        |                         |                       |               |                             |                    |      |
| 0  | 80.0                   | 48.0                    | 32.0                  | 18            | 2.0                         | 23                 | 16   |
| 15   | 80.0                   | 40.0                    | 40.0                  | 18            | 2.0                         | 23                 | 5    |
| 30   | 80.0                   | 18.0                    | 62.0                  | 18            | 2.0                         | 23                 | 7    |
| 45   | 80.0                   | 2.0                     | 78.0                  | 12            | 1.3                         | 23                 | 9    |

Test # 23

Grade - 512  
 Weight - 8.88 oz/ft<sup>2</sup>  
 Influent - Raw Water  
 Temperature of influent - 16°C  
 Turbidity of raw water - 22

pH of influent - not determined  
 pH of effluent - not determined  
 Color of influent - not determined  
 Color of effluent - not determined  
 Clear - not determined

| <u>Time</u><br><u>(min)</u> | <u>Input</u><br><u>Head</u><br><u>(psi)</u> | <u>Output</u><br><u>Head</u><br><u>(psi)</u> | <u>Loss</u><br><u>Head</u><br><u>(psi)</u> | <u>Rate</u><br><u>(gpm)</u> | <u>Rate</u><br><u>gpm/ft<sup>2</sup></u> | <u>Turbidity</u><br><u>(ppm)</u> |             |
|-----------------------------|---|--|--|-----------------------------|--|----------------------------------|-------------|
|                             |   |  |  |                             |  | <u>Inf.</u>                      | <u>Eff.</u> |
| 0                           | 44.0  | 8.0  | 36.0                                       | 45                          | 5.0                                      | 22                               | 2           |
| 15                          | 80.0  | 7.0  | 73.0                                       | 22                          | 2.4                                      | 22                               | 5           |
| 30                          | 86.0  | 6.0  | 80.0                                       | 14                          | 1.5                                      | 22                               | 15          |
| 45                          | 86.0  | 5.0  | 81.0                                       | 11                          | 1.2                                      | 22                               | 17          |
| 60                          | 86.0  | 5.0  | 81.0                                       | 9                           | 1.0                                      | 22                               | 18          |

Test # 24

Grade - 512  
 Weight - 10.66 oz/ft<sup>2</sup>  
 Influent - Raw Water  
 Temperature of influent - 15.5°C  
 Turbidity of raw water - 21

pH of influent - 8.3  
 pH of effluent - 8.3  
 Color of influent - not determined  
 Color of effluent - not determined  
 Clear - 150 seconds

| <u>Time</u><br><u>(min)</u> | <u>Input</u><br><u>Head</u><br><u>(psi)</u> | <u>Output</u><br><u>Head</u><br><u>(psi)</u> | <u>Loss</u><br><u>Head</u><br><u>(psi)</u> | <u>Rate</u><br><u>(gpm)</u> | <u>Rate</u><br><u>gpm/ft<sup>2</sup></u> | <u>Turbidity</u><br><u>(ppm)</u> |             |
|-----------------------------|---|--|--|-----------------------------|--|----------------------------------|-------------|
|                             |   |  |  |                             |  | <u>Inf.</u>                      | <u>Eff.</u> |
| 0                           | 54.0  | 7.5  | 46.5                                       | 38                          | 4.2                                      | 21                               | 2           |
| 15                          | 76.0  | 6.0  | 70.0                                       | 25                          | 2.8                                      | 21                               | 3           |
| 30                          | 83.0  | 6.0  | 77.0                                       | 15                          | 1.7                                      | 21                               | 10          |
| 45                          | 84.0  | 6.0  | 78.0                                       | 14                          | 1.5                                      | 21                               | 15          |

Test # 25

Grade - 545  
 Weight - 3.55 oz/ft<sup>2</sup>  
 Influent - Coagulated Water  
 Temperature of influent - 14.5°C  
 Turbidity of coagulated water - 10

pH of influent - 8.8  
 pH of effluent - 8.8  
 Color of influent - not determined  
 Color of effluent - not determined  
 Clear - 180 seconds

| Time<br>(min)                                | Input<br>Head<br>(psi) | Output<br>Head<br>(psi) | Loss<br>Head<br>(psi) | Rate<br>(gpm) | Rate<br>gpm/ft <sup>2</sup> | Turbidity<br>(ppm) |      |
|--|------------------------|-------------------------|-----------------------|---------------|-----------------------------|--------------------|------|
|  |                        |                         |                       |               |                             | Inf.               | Eff. |
| 0  | 54.0                   | 7.5                     | 46.5                  | 38            | 4.2                         | 30                 | 0.1  |
| 15   | 60.0                   | 7.5                     | 52.5                  | 36            | 4.0                         | 10                 | 0.1  |
| 30   | 71.0                   | 7.5                     | 63.5                  | 29            | 3.2                         | 10                 | 0.1  |
| 45   | 76.0                   | 7.0                     | 69.0                  | 25            | 2.8                         | 10                 | 0.1  |
| 60   | 78.0                   | 6.0                     | 72.0                  | 23            | 2.6                         | 10                 | 0.1  |
| 75   | 80.0                   | 5.0                     | 75.0                  | 21            | 2.3                         | 10                 | 0.1  |
| 90   | 81.0                   | 5.0                     | 76.0                  | 19            | 2.1                         | 10                 | 0.1  |
| 105  | 82.0                   | 5.0                     | 77.0                  | 18            | 2.0                         | 10                 | 0.1  |
| 120  | 82.0                   | 5.0                     | 77.0                  | 17            | 1.9                         | 10                 | 0.1  |
| 135  | 82.0                   | 5.0                     | 77.0                  | 17            | 1.9                         | 10                 | 0.1  |
| 150  | 82.0                   | 5.0                     | 77.0                  | 17            | 1.9                         | 10                 | 0.1  |
| 165  | 83.0                   | 5.0                     | 78.0                  | 16            | 1.8                         | 10                 | 0.1  |
| Filter bumped and same diatomite redeposited |                        |                         |                       |               |                             |                    |      |
| 0  | 56.0                   | 7.5                     | 48.5                  | 38            | 4.2                         | 6                  | 0.1  |
| 30   | 76.0                   | 6.0                     | 70.0                  | 26            | 2.9                         | 6                  | 0.1  |
| 60   | 80.0                   | 6.0                     | 74.0                  | 20            | 2.2                         | 6                  | 1.0  |
| 90   | 83.0                   | 6.0                     | 77.0                  | 17            | 1.9                         | 6                  | 1.5  |
| 105  | 84.0                   | 6.0                     | 78.0                  | 16            | 1.8                         | 6                  | 2.5  |

Test # 26

Grade - 545  
 Weight - 1.77 oz/ft<sup>2</sup>  
 Influent - Coagulated Water  
 Temperature of influent - 13.5°C  
 Turbidity of raw water - 21

pH of influent - not determined  
 pH of effluent - not determined  
 Color of influent - not determined  
 Color of effluent - not determined  
 Clear - 130 seconds

| Time<br>(min)                                | Input<br>Head<br>(psi) | Output<br>Head<br>(psi) | Loss<br>Head<br>(psi) | Rate<br>(gpm) | Rate<br>gpm/ft <sup>2</sup> | Turbidity<br>(ppm) |      |
|--|------------------------|-------------------------|-----------------------|---------------|-----------------------------|--------------------|------|
|  |                        |                         |                       |               |                             | Inf.               | Eff. |
| 0  | 46.0                   | 8.0                     | 38.0                  | 43            | 4.8                         | 53                 | 1.0  |
| 30   | 79.0                   | 7.0                     | 72.0                  | 23            | 2.6                         | 13                 | 0.5  |
| 60   | 82.0                   | 6.0                     | 76.0                  | 18            | 2.0                         | 13                 | 2.0  |
| 90   | 84.0                   | 6.0                     | 78.0                  | 15            | 1.7                         | 12                 | 2.0  |
| 120  | 84.0                   | 6.0                     | 78.0                  | 14            | 1.5                         | 9                  | 2.5  |
| Filter bumped and same diatomite redeposited |                        |                         |                       |               |                             |                    |      |
| 0  | 52.0                   | 7.5                     | 44.5                  | 40            | 4.4                         | 9                  | 2.0  |
| 30   | 80.0                   | 5.0                     | 75.0                  | 20            | 2.2                         | 9                  | 1.0  |
| 60   | 84.0                   | 6.0                     | 78.0                  | 16            | 1.8                         | 9                  | 2.5  |

Test # 27

Grade - Hyflo Super-Gel  
 Weight - 1.77 oz/ft<sup>2</sup>  
 Influent - Coagulated Water  
 Temperature of influent - 13.5°C  
 Turbidity of raw water - 21

pH of influent - not determined  
 pH of effluent - not determined  
 Color of influent - not determined  
 Color of effluent - not determined  
 Clear - 55 seconds

| Time<br>(min) | Input<br>Head<br>(psi) | Output<br>Head<br>(psi) | Loss<br>Head<br>(psi) | Rate<br>(gpm) | Rate<br>gpm/ft <sup>2</sup> | Turbidity<br>(ppm) |      |
|---------------|------------------------|-------------------------|-----------------------|---------------|-----------------------------|--------------------|------|
|               |                        |                         |                       |               |                             | Inf.               | Eff. |
| 0             | 32.0                   | 8.0                     | 24                    | 47            | 5.2                         | 11                 | 0.1  |
| 15            | 74.0                   | 7.0                     | 67                    | 27            | 3.0                         | 11                 | 0.1  |
| 30            | 81.0                   | 6.0                     | 75                    | 20            | 2.2                         | 11                 | 0.1  |
| 45            | 84.0                   | 5.0                     | 79                    | 15            | 1.7                         | 11                 | 0.1  |
| 60            | 85.0                   | 5.0                     | 80                    | 14            | 1.5                         | 11                 | 0.2  |
| 75            | 85.0                   | 5.0                     | 80                    | 12            | 1.3                         | 11                 | 0.5  |
| 90            | 85.0                   | 5.0                     | 80                    | 10            | 1.1                         | 11                 | 1.0  |

Test # 28

Grade - 512  
 Weight - 1.77 oz/ft<sup>2</sup>  
 Influent - Coagulated Water  
 Temperature of influent - 14°C  
 Turbidity of coagulated water - 10

pH of influent - not determined  
 pH of effluent - not determined  
 Color of influent - not determined  
 Color of effluent - not determined  
 Clear - 90 seconds

| Time<br>(min)                                | Input<br>Head<br>(psi) | Output<br>Head<br>(psi) | Loss<br>Head<br>(psi) | Rate<br>(gpm) | Rate<br>gpm/ft <sup>2</sup> | Turbidity<br>(ppm) |      |
|--|------------------------|-------------------------|-----------------------|---------------|-----------------------------|--------------------|------|
|  |                        |                         |                       |               |                             | Inf.               | Eff. |
| 0  | 42.0                   | 8.0                     | 34.0                  | 44            | 4.9                         | 10                 | 0.1  |
| 15   | 63.0                   | 7.5                     | 55.5                  | 36            | 4.0                         | 10                 | 0.1  |
| 30   | 73.0                   | 7.0                     | 66.0                  | 27            | 3.0                         | ---                | 0.1  |
| 45   | 77.0                   | 7.0                     | 70.0                  | 24            | 2.7                         | ---                | 0.1  |
| 60   | 80.0                   | 6.5                     | 73.5                  | 21            | 2.3                         | ---                | 0.1  |
| 75   | 80.0                   | 6.0                     | 74.0                  | 20            | 2.2                         | ---                | 0.1  |
| 90   | 81.0                   | 6.0                     | 75.0                  | 18            | 2.0                         | ---                | 0.1  |
| 105  | 82.0                   | 6.0                     | 76.0                  | 17            | 1.9                         | ---                | 0.1  |
| Filter bumped and same diatomite redeposited |                        |                         |                       |               |                             |                    |      |
| 0  | 45.0                   | 7.5                     | 37.5                  | 44            | 4.9                         | 10                 | 0.1  |
| 15   | 67.0                   | 7.5                     | 59.5                  | 34            | 3.8                         | ---                | 0.1  |
| 45   | 78.0                   | 7.0                     | 71.0                  | 24            | 2.7                         | ---                | 0.1  |
| 60   | 80.0                   | 6.0                     | 74.0                  | 22            | 2.4                         | ---                | 0.1  |

Test # 29

Grade - 512  
 Weight - 1 oz/ft<sup>2</sup>  
 Influent - Coagulated Water  
 Temperature of influent - 14.5°C  
 Turbidity of raw water - 22

pH of influent - not determined  
 pH of effluent - not determined  
 Color of influent - not determined  
 Color of effluent - not determined  
 Clear - 120 seconds

| Time<br>(min)                                | Input<br>Head<br>(psi) | Output<br>Head<br>(psi) | Loss<br>Head<br>(psi) | Rate<br>(gpm) | Rate <sup>2</sup><br>gpm/ft <sup>2</sup> | Turbidity<br>(ppm) |      |
|--|------------------------|-------------------------|-----------------------|---------------|--|--------------------|------|
|  |                        |                         |                       |               |  | Inf.               | Eff. |
| 0  | 40.0                   | 7.0                     | 33.0                  | 45            | 5.0                                      | 11                 | 0.1  |
| 15   | 63.0                   | 6.0                     | 57.0                  | 36            | 4.0                                      | 11                 | 0.1  |
| 30   | 78.0                   | 5.0                     | 73.0                  | 25            | 2.8                                      | 11                 | 0.1  |
| 45   | 80.0                   | 5.0                     | 75.0                  | 21            | 2.1                                      | 11                 | 0.1  |
| 60   | 82.0                   | 5.0                     | 77.0                  | 18            | 2.0                                      | 11                 | 0.1  |
| 75   | 82.0                   | 5.0                     | 77.0                  | 17            | 1.9                                      | 11                 | 0.1  |
| 90   | 82.5                   | 5.5                     | 77.0                  | 16            | 1.8                                      | 11                 | 0.1  |
| Filter bumped and same diatomite redeposited |                        |                         |                       |               |  |                    |      |
| 0  | 43.0                   | 7.5                     | 35.5                  | 43            | 4.8                                      | 7                  | 0.1  |
| 15   | 70.0                   | 7.5                     | 62.5                  | 30            | 3.3                                      | 7                  | 0.1  |
| 30   | 76.0                   | 6.0                     | 70.0                  | 25            | 2.8                                      | 7                  | 0.1  |
| 45   | 78.0                   | 6.0                     | 72.0                  | 23            | 2.6                                      | 7                  | 0.1  |
| 60   | 80.0                   | 6.0                     | 74.0                  | 21            | 2.3                                      | 7                  | 0.1  |
| 75   | 81.0                   | 6.0                     | 75.0                  | 20            | 2.2                                      | 7                  | 0.1  |
| 120  | 82.0                   | 6.0                     | 76.0                  | 17            | 1.9                                      | 7                  | 0.1  |

Test # 30

Grade - 512  
 Weight -  $\frac{1}{2}$  oz/ft<sup>2</sup>  
 Influent - Coagulated Water  
 Temperature of influent - 14.5°C  
 Turbidity of raw water - 24

pH of influent - 8.3  
 pH of effluent - 8.3  
 Color of influent - not determined  
 Color of effluent - not determined  
 Clear - 125 seconds

| Time<br>(min) | Input<br>Head<br>(psi) | Output<br>Head<br>(psi) | Loss<br>Head<br>(psi) | Rate<br>(gpm) | Rate <sup>2</sup><br>gpm/ft <sup>2</sup> | Turbidity<br>(ppm) |      |
|---------------|------------------------|-------------------------|-----------------------|---------------|--|--------------------|------|
|               |                        |                         |                       |               |  | Inf.               | Eff. |
| 0             | 40.0                   | 8.0                     | 32.0                  | 48            | 5.3                                      | 7                  | 0.1  |
| 15            | 60.0                   | 7.5                     | 52.5                  | 36            | 4.0                                      | 7                  | 0.1  |
| 30            | 72.0                   | 7.0                     | 65.0                  | 29            | 3.2                                      | 7                  | 0.1  |
| 45            | 76.0                   | 6.5                     | 69.5                  | 25            | 2.8                                      | 7                  | 0.1  |
| 60            | 78.0                   | 6.0                     | 72.0                  | 23            | 2.6                                      | 7                  | 0.1  |
| 75            | 79.0                   | 6.0                     | 73.0                  | 22            | 2.4                                      | 7                  | 0.1  |
| 90            | 80.0                   | 6.0                     | 74.0                  | 21            | 2.3                                      | 7                  | 0.1  |
| 105           | 80.5                   | 5.5                     | 75.0                  | 20            | 2.2                                      | 7                  | 0.1  |
| 120           | 80.5                   | 5.5                     | 75.0                  | 20            | 2.2                                      | 7                  | 0.2  |
| 135           | 81.0                   | 5.0                     | 76.0                  | 20            | 2.2                                      | 7                  | 0.3  |
| 150           | 81.5                   | 5.0                     | 76.5                  | 20            | 2.2                                      | 7                  | 0.5  |
| 180           | 82.0                   | 5.0                     | 77.0                  | 20            | 2.2                                      | 7                  | 1.0  |
| 210           | 82.0                   | 5.0                     | 77.0                  | 18            | 2.0                                      | 7                  | 1.2  |

Test # 31

Grade - 512  
 Weight -  $\frac{1}{4}$  oz/ft<sup>2</sup>  
 Influent - Coagulated Water  
 Temperature of influent - 14°C  
 Turbidity of raw water - 23

pH of influent - not determined  
 pH of effluent - not determined  
 Color of influent - 5  
 Color of effluent - 5  
 Clear - not determined

| Time<br>(min) | Input<br>Head<br>(psi) | Output<br>Head<br>(psi) | Loss<br>Head<br>(psi) | Rate<br>(gpm) | Rate<br>gpm/ft <sup>2</sup> | Turbidity<br>(ppm) |      |
|---------------|------------------------|-------------------------|-----------------------|---------------|-----------------------------|--------------------|------|
|               |                        |                         |                       |               |                             | Inf.               | Eff. |
| 0             | 42.0                   | 7.5                     | 34.5                  | 43            | 4.8                         | 11                 | 2.0  |
| 30            | 71.0                   | 7.0                     | 64.0                  | 29            | 3.2                         | 11                 | 2.0  |
| 60            | 78.0                   | 6.5                     | 71.5                  | 24            | 2.7                         | 10                 | 2.5  |
| 90            | 79.0                   | 6.0                     | 73.0                  | 22            | 2.4                         | 9                  | 2.7  |
| 120           | 80.5                   | 6.0                     | 74.5                  | 21            | 2.3                         | 8                  | 3.0  |
| 150           | 81.0                   | 5.5                     | 75.5                  | 19            | 2.1                         | 7                  | 2.5  |

Test # 32

Grade - 535  
 Weight -  $\frac{1}{2}$  oz/ft<sup>2</sup>  
 Influent - Coagulated Water  
 Temperature of influent - 14°C  
 Turbidity of raw water - 23

pH of influent - not determined  
 pH of effluent - not determined  
 Color of influent - not determined  
 Color of effluent - not determined  
 Clear - 80 seconds

| Time<br>(min) | Input<br>Head<br>(psi) | Output<br>Head<br>(psi) | Loss<br>Head<br>(psi) | Rate<br>(gpm) | Rate<br>gpm/ft <sup>2</sup> | Turbidity<br>(ppm) |      |
|---------------|------------------------|-------------------------|-----------------------|---------------|-----------------------------|--------------------|------|
|               |                        |                         |                       |               |                             | Inf.               | Eff. |
| 0             | 26.0                   | 8.0                     | 18.0                  | 50            | 5.6                         | 5                  | 1.5  |
| 30            | 71.0                   | 7.0                     | 64.0                  | 29            | 3.2                         | 5                  | 1.5  |
| 60            | 78.0                   | 6.5                     | 71.5                  | 23            | 2.6                         | 5                  | 1.5  |
| 90            | 80.0                   | 6.0                     | 74.0                  | 21            | 2.3                         | 5                  | 2.0  |
| 120           | 82.0                   | 6.0                     | 76.0                  | 20            | 2.2                         | 5                  | 2.0  |
| 150           | 82.0                   | 6.0                     | 76.0                  | 18            | 2.0                         | 5                  | 2.0  |

Test # 33

Grade - Hyflo Super-Cel  
 Weight - 1 oz/ft<sup>2</sup>  
 Influent - Coagulated Water  
 Temperature of influent - 13.5°C  
 Turbidity of raw water - 28

pH of influent - 8.3  
 pH of effluent - 8.3  
 Color of influent - not determined  
 Color of effluent - not determined  
 Clear - 70 seconds

| Time<br>(min) | Input<br>Head<br>(psi) | Output<br>Head<br>(psi) | Loss<br>Head<br>(psi) | Rate<br>(gpm) | Rate<br>gpm/ft <sup>2</sup> | Turbidity<br>(ppm) |      |
|---------------|------------------------|-------------------------|-----------------------|---------------|-----------------------------|--------------------|------|
|               |                        |                         |                       |               |                             | Inf.               | Eff. |
| 0             | 32.0                   | 8.0                     | 24.0                  | 47            | 5.2                         | 22                 | 0.1  |
| 30            | 78.0                   | 6.0                     | 72.0                  | 24            | 2.7                         | 22                 | 0.1  |
| 45            | 80.0                   | 6.0                     | 74.0                  | 20            | 2.2                         | 22                 | 1.0  |
| 60            | 81.0                   | 6.0                     | 75.0                  | 20            | 2.2                         | 22                 | 1.5  |
| 75            | 82.0                   | 5.5                     | 76.5                  | 18            | 2.0                         | 22                 | 2.0  |



Test # 34

Grade - 512  
 Weight - 0.75 oz/ft<sup>2</sup>  
 Influent - Coagulated Water  
 Temperature of influent - 14°C  
 Turbidity of raw water - 25

pH of influent - 8.3  
 pH of effluent - 8.3  
 Color of influent - not determined  
 Color of effluent - not determined  
 Clear - 60 seconds

| Time<br>(min) | Input<br>Head<br>(psi) | Output<br>Head<br>(psi) | Loss<br>Head<br>(psi) | Rate<br>(gpm) | Rate<br>gpm/ft <sup>2</sup> | Turbidity<br>(ppm) |      |
|---------------|------------------------|-------------------------|-----------------------|---------------|-----------------------------|--------------------|------|
|               |                        |                         |                       |               |                             | Inf.               | Eff. |
| 0             | 32.0                   | 7.5                     | 24.5                  | 46            | 5.1                         | 9                  | 0.1  |
| 15            | 76.0                   | 6.0                     | 70.0                  | 25            | 2.8                         | 9                  | 0.1  |
| 30            | 81.0                   | 6.0                     | 75.0                  | 19            | 2.1                         | 9                  | 0.1  |
| 45            | 82.0                   | 5.0                     | 77.0                  | 17            | 1.9                         | 9                  | 0.1  |
| 60            | 84.0                   | 5.0                     | 79.0                  | 15            | 1.7                         | 9                  | 0.1  |

Test # 35

Grade - 501  
 Weight - 1.25 oz/ft<sup>2</sup>  
 Influent - Coagulated Water  
 Temperature of influent - 13.5°C  
 Turbidity of raw water - 28

pH of influent - not determined  
 pH of effluent - not determined  
 Color of influent - 5  
 Color of effluent - 5  
 Clear - 70 seconds

| Time<br>(min) | Input<br>Head<br>(psi) | Output<br>Head<br>(psi) | Loss<br>Head<br>(psi) | Rate<br>(gpm) | Rate<br>gpm/ft <sup>2</sup> | Turbidity<br>(ppm) |      |
|---------------|------------------------|-------------------------|-----------------------|---------------|-----------------------------|--------------------|------|
|               |                        |                         |                       |               |                             | Inf.               | Eff. |
| 0             | 28.0                   | 8.0                     | 20.0                  | 49            | 5.4                         | 22                 | 0.1  |
| 15            | 70.0                   | 7.0                     | 63.0                  | 31            | 3.4                         | 22                 | 0.1  |
| 30            | 82.0                   | 5.5                     | 76.5                  | 20            | 2.2                         | 22                 | 0.1  |
| 45            | 84.0                   | 5.0                     | 79.0                  | 15            | 1.7                         | 22                 | 0.2  |
| 60            | 84.0                   | 5.0                     | 79.0                  | 14            | 1.5                         | 22                 | 0.5  |

Test # 36

Grade - 545  
 Weight - 3 oz/ft<sup>2</sup>  
 Influent - Coagulated Water  
 Temperature of influent - 14°C  
 Turbidity of raw water - 25

pH of influent - not determined  
 pH of effluent - not determined  
 Color of influent - not determined  
 Color of effluent - not determined  
 Clear - 35 seconds

| Time<br>(min) | Input<br>Head<br>(psi) | Output<br>Head<br>(psi) | Loss<br>Head<br>(psi) | Rate<br>(gpm) | Rate<br>gpm/ft <sup>2</sup> | Turbidity<br>(ppm) |      |
|---------------|------------------------|-------------------------|-----------------------|---------------|-----------------------------|--------------------|------|
|               |                        |                         |                       |               |                             | Inf.               | Eff. |
| 0             | 22.0                   | 10.0                    | 12.0                  | 50            | 5.6                         | 9                  | 0.1  |
| 15            | 63.0                   | 7.5                     | 55.5                  | 36            | 4.0                         | 9                  | 0.1  |
| 30            | 78.0                   | 6.0                     | 72.0                  | 25            | 2.8                         | 9                  | 0.1  |
| 45            | 82.0                   | 5.5                     | 76.5                  | 20            | 2.2                         | 9                  | 0.1  |
| 60            | 84.0                   | 5.0                     | 79.0                  | 18            | 2.0                         | 9                  | 0.1  |
| 75            | 84.0                   | 5.0                     | 79.0                  | 17            | 1.9                         | 9                  | 0.1  |

Test # 37

Grade - 535  
 Weight - 1 oz/ft<sup>2</sup>  
 Influent - Coagulated Water  
 Temperature of influent - 13.5°C  
 Turbidity of raw water - 24

pH of influent - not determined  
 pH of effluent - not determined  
 Color of influent - not determined  
 Color of effluent - not determined  
 Clear - 44 seconds

| Time<br>(min) | Input         | Output        | Loss          | Rate<br>(gpm) | Rate<br>gpm/ft <sup>2</sup> | Turbidity<br>(ppm) |      |
|---------------|---------------|---------------|---------------|---------------|-----------------------------|--------------------|------|
|               | Head<br>(psi) | Head<br>(psi) | Head<br>(psi) |               |                             | Inf.               | Eff. |
| 0             | 25.0          | 15.0          | 10.0          | 50            | 5.6                         | 6                  | 0.1  |
| 15            | 66.0          | 7.5           | 58.5          | 35            | 3.9                         | 6                  | 0.1  |
| 30            | 79.0          | 7.0           | 72.0          | 24            | 2.7                         | 6                  | 0.1  |
| 45            | 82.0          | 5.5           | 76.5          | 18            | 2.0                         | 6                  | 0.1  |
| 60            | 83.0          | 5.0           | 78.0          | 17            | 1.9                         | 6                  | 0.1  |

Test # 38

Grade - 545  
 Weight - 4 oz/ft<sup>2</sup>  
 Influent - Coagulated Water  
 Temperature of influent - 13.5°C  
 Turbidity of raw water - 24

pH of influent - not determined  
 pH of effluent - not determined  
 Color of influent - 4  
 Color of effluent - 4  
 Clear - 39 seconds

| Time<br>(min) | Input         | Output        | Loss          | Rate<br>(gpm) | Rate<br>gpm/ft <sup>2</sup> | Turbidity<br>(ppm) |      |
|---------------|---------------|---------------|---------------|---------------|-----------------------------|--------------------|------|
|               | Head<br>(psi) | Head<br>(psi) | Head<br>(psi) |               |                             | Inf.               | Eff. |
| 0             | 24.0          | 14.0          | 10.0          | 50            | 5.6                         | 6                  | 0.1  |
| 30            | 60.0          | 7.5           | 52.5          | 37            | 4.1                         | 6                  | 0.1  |
| 45            | 72.0          | 7.0           | 65.0          | 30            | 3.3                         | 6                  | 0.1  |
| 60            | 77.0          | 6.0           | 71.0          | 24            | 2.7                         | 6                  | 0.1  |
| 75            | 80.0          | 5.5           | 74.5          | 22            | 2.4                         | 6                  | 0.1  |
| 90            | 81.0          | 5.0           | 76.0          | 21            | 2.3                         | 6                  | 0.1  |
| 120           | 83.0          | 5.0           | 78.0          | 18            | 2.0                         | 6                  | 0.1  |

Test # 39

Grade - Hyflo Super-Cel  
 Weight - 3 oz/ft<sup>2</sup>  
 Influent - Coagulated Water  
 Temperature of influent - 12°C  
 Turbidity of raw water - 25

pH of influent - not determined  
 pH of effluent - not determined  
 Color of influent - not determined  
 Color of effluent - not determined  
 Clear - 60 seconds

| Time<br>(min) | Input         | Output        | Loss          | Rate<br>(gpm) | Rate<br>gpm/ft <sup>2</sup> | Turbidity<br>(ppm) |      |
|---------------|---------------|---------------|---------------|---------------|-----------------------------|--------------------|------|
|               | Head<br>(psi) | Head<br>(psi) | Head<br>(psi) |               |                             | Inf.               | Eff. |
| 0             | 33.0          | 8.0           | 25.0          | 48            | 5.3                         | 4                  | 0.1  |
| 15            | 46.0          | 7.5           | 38.5          | 46            | 5.1                         | 4                  | 0.1  |
| 30            | 76.0          | 7.0           | 69.0          | 31            | 3.4                         | 4                  | 0.1  |
| 45            | 86.0          | 5.0           | 81.0          | 18            | 2.0                         | 4                  | 0.1  |
| 60            | 88.0          | 5.0           | 83.0          | 15            | 1.7                         | 4                  | 0.1  |

Test # 40

Grade - 501  
 Weight - 3 oz/ft<sup>2</sup>  
 Influent - Coagulated Water  
 Temperature of influent - 14.5°C  
 Turbidity of raw water - 25

pH of influent - 8.4  
 pH of effluent - 8.4  
 Color of influent - not determined  
 Color of effluent - not determined  
 Clear - not determined

| Time<br>(min) | Input<br>Head<br>(psi) | Output<br>Head<br>(psi) | Loss<br>Head<br>(psi) | Rate<br>(gpm) | Rate<br>gpm/ft <sup>2</sup> | Turbidity<br>(ppm) |      |
|---------------|------------------------|-------------------------|-----------------------|---------------|-----------------------------|--------------------|------|
|               |                        |                         |                       |               |                             | Inf.               | Eff. |
| 0             | 28.0                   | 10.0                    | 18.0                  | 50            | 5.6                         | 5                  | 0.1  |
| 15            | 68.0                   | 7.5                     | 60.5                  | 36            | 4.0                         | 5                  | 0.1  |
| 30            | 83.0                   | 6.0                     | 77.0                  | 24            | 2.7                         | 5                  | 0.1  |
| 45            | 85.0                   | 5.5                     | 79.5                  | 20            | 2.2                         | 5                  | 0.1  |
| 60            | 86.0                   | 5.0                     | 81.0                  | 17            | 1.9                         | 5                  | 0.1  |

Test # 41

Grade - 545  
 Weight - 5 oz/ft<sup>2</sup>  
 Influent - Coagulated Water  
 Temperature of influent - 13.5°C  
 Turbidity of raw water - 24

pH of influent - not determined  
 pH of effluent - not determined  
 Color of influent - not determined  
 Color of effluent - not determined  
 Clear - 37 seconds

| Time<br>(min) | Input<br>Head<br>(psi) | Output<br>Head<br>(psi) | Loss<br>Head<br>(psi) | Rate<br>(gpm) | Rate<br>gpm/ft <sup>2</sup> | Turbidity<br>(ppm) |      |
|---------------|------------------------|-------------------------|-----------------------|---------------|-----------------------------|--------------------|------|
|               |                        |                         |                       |               |                             | Inf.               | Eff. |
| 0             | 26.0                   | 17.0                    | 9.0                   | 50            | 5.6                         | 6                  | 0.1  |
| 15            | 56.0                   | 7.5                     | 48.5                  | 37            | 4.1                         | 6                  | 0.1  |
| 30            | 81.0                   | 6.0                     | 75.0                  | 21            | 2.3                         | 6                  | 0.1  |
| 45            | 83.0                   | 5.5                     | 77.5                  | 17            | 1.9                         | 6                  | 0.1  |
| 60            | 84.0                   | 5.0                     | 79.0                  | 15            | 1.7                         | 6                  | 1.0  |

Test # 42

Grade - 545  
 Weight - 3.5 oz/ft<sup>2</sup>  
 Influent - Coagulated Water  
 Temperature of influent - 13.5°C  
 Turbidity of raw water - 26

pH of influent - not determined  
 pH of effluent - not determined  
 Color of influent - not determined  
 Color of effluent - not determined  
 Clear - 60 seconds.

| Time<br>(min) | Input<br>Head<br>(psi) | Output<br>Head<br>(psi) | Loss<br>Head<br>(psi) | Rate<br>(gpm) | Rate<br>gpm/ft <sup>2</sup> | Turbidity<br>(ppm) |      |
|---------------|------------------------|-------------------------|-----------------------|---------------|-----------------------------|--------------------|------|
|               |                        |                         |                       |               |                             | Inf.               | Eff. |
| 0             | 24.0                   | 13.0                    | 11.0                  | 50            | 5.6                         | 7                  | 0.1  |
| 15            | 46.0                   | 7.5                     | 38.0                  | 44            | 4.9                         | 7                  | 0.1  |
| 30            | 72.0                   | 7.0                     | 65.0                  | 30            | 3.3                         | 7                  | 0.1  |
| 45            | 80.0                   | 6.0                     | 74.0                  | 22            | 2.4                         | 7                  | 0.1  |
| 60            | 82.0                   | 6.0                     | 76.0                  | 20            | 2.2                         | 7                  | 0.1  |
| 75            | 83.0                   | 6.0                     | 77.0                  | 18            | 2.0                         | 7                  | 0.1  |
| 90            | 84.0                   | 5.5                     | 78.5                  | 17            | 1.9                         | 7                  | 0.1  |
| 105           | 84.0                   | 5.0                     | 79.0                  | 16            | 1.8                         | 7                  | 0.1  |

Test # 43

Grade - Hyflo Super-Cel  
 Weight - 0.5 oz/ft<sup>2</sup>  
 Influent - Coagulated Water  
 Temperature of influent - 13.5°C  
 Turbidity of raw water - 26

pH of influent - not determined  
 pH of effluent - not determined  
 Color of influent - not determined  
 Color of effluent - not determined  
 Clear - 50 seconds

| Time<br>(min) | Input<br>Head<br>(psi) | Output<br>Head<br>(psi) | Loss<br>Head<br>(psi) | Rate<br>(gpm) | Rate<br>gpm/ft <sup>2</sup> | Turbidity<br>(ppm) |      |
|---------------|------------------------|-------------------------|-----------------------|---------------|-----------------------------|--------------------|------|
|               |                        |                         |                       |               |                             | Inf.               | Eff. |
| 0             | 28.0                   | 9.0                     | 19.0                  | 50            | 5.6                         | 7                  | 0.1  |
| 15            | 64.0                   | 7.5                     | 56.5                  | 41            | 4.5                         | 7                  | 0.1  |
| 30            | 82.0                   | 7.0                     | 75.0                  | 25            | 2.8                         | 7                  | 0.1  |
| 45            | 84.0                   | 6.0                     | 78.0                  | 22            | 2.4                         | 7                  | 0.1  |
| 60            | 86.0                   | 5.5                     | 80.5                  | 18            | 2.0                         | 7                  | 0.1  |

Test # 44

Grade - 535  
 Weight - 2 oz/ft<sup>2</sup>  
 Influent - Coagulated Water  
 Temperature of influent - 11°C  
 Turbidity of raw water - 24

pH of influent - not determined  
 pH of effluent - not determined  
 Color of influent - not determined  
 Color of effluent - not determined  
 Clear - 60 seconds

| Time<br>(min) | Input<br>Head<br>(psi) | Output<br>Head<br>(psi) | Loss<br>Head<br>(psi) | Rate<br>(gpm) | Rate<br>gpm/ft <sup>2</sup> | Turbidity<br>(ppm) |      |
|---------------|------------------------|-------------------------|-----------------------|---------------|-----------------------------|--------------------|------|
|               |                        |                         |                       |               |                             | Inf.               | Eff. |
| 0             | 24.0                   | 9.0                     | 15.0                  | 50            | 5.6                         | 7                  | 0.1  |
| 15            | 42.0                   | 8.0                     | 34.0                  | 43            | 4.8                         | 7                  | 0.1  |
| 30            | 72.0                   | 7.5                     | 64.5                  | 35            | 3.9                         | 7                  | 0.1  |
| 45            | 84.0                   | 6.0                     | 78.0                  | 21            | 2.3                         | 7                  | 0.1  |
| 60            | 86.0                   | 5.0                     | 81.0                  | 18            | 2.0                         | 7                  | 0.1  |

Test # 45

Grade - 535  
 Weight - 3 oz/ft<sup>2</sup>  
 Influent - Coagulated Water  
 Temperature of influent - 12°C  
 Turbidity of raw water - 25

pH of influent - 8.4  
 pH of effluent - 8.4  
 Color of influent - not determined  
 Color of effluent - not determined  
 Clear - 50 seconds

| Time<br>(min) | Input<br>Head<br>(psi) | Output<br>Head<br>(psi) | Loss<br>Head<br>(psi) | Rate<br>(gpm) | Rate<br>gpm/ft <sup>2</sup> | Turbidity<br>(ppm) |      |
|---------------|------------------------|-------------------------|-----------------------|---------------|-----------------------------|--------------------|------|
|               |                        |                         |                       |               |                             | Inf.               | Eff. |
| 0             | 24.0                   | 13.0                    | 11.0                  | 50            | 5.6                         | 4                  | 0.1  |
| 15            | 38.0                   | 7.5                     | 30.5                  | 48            | 5.3                         | 4                  | 0.1  |
| 30            | 55.0                   | 7.5                     | 47.5                  | 43            | 4.8                         | 4                  | 0.1  |
| 45            | 80.0                   | 6.0                     | 74.0                  | 27            | 3.0                         | 4                  | 0.1  |
| 60            | 86.0                   | 5.0                     | 81.0                  | 18            | 2.0                         | 4                  | 0.1  |

Test # 46

Grade - 501  
 Weight - 4 oz/ft<sup>2</sup>  
 Influent - Coagulated Water  
 Temperature of influent - 11°C  
 Turbidity of coagulated water - 5

pH of influent - not determined  
 pH of effluent - not determined  
 Color of influent - not determined  
 Color of effluent - not determined  
 Clear - 70 seconds

| Time<br>(min) | Input<br>Head<br>(psi) | Output<br>Head<br>(psi) | Loss<br>Head<br>(psi) | Rate<br>(gpm) | Rate<br>gpm/ft <sup>2</sup> | Turbidity<br>(ppm) |      |
|---------------|------------------------|-------------------------|-----------------------|---------------|-----------------------------|--------------------|------|
|               |                        |                         |                       |               |                             | Inf.               | Eff. |
| 0             | 25.0                   | 9.0                     | 16.0                  | 47            | 5.2                         | 5                  | 0.1  |
| 15            | 56.0                   | 8.0                     | 48.0                  | 38            | 4.2                         | 5                  | 0.1  |
| 30            | 82.0                   | 6.0                     | 76.0                  | 20            | 2.2                         | 5                  | 0.1  |
| 45            | 86.0                   | 5.5                     | 80.5                  | 16            | 1.8                         | 5                  | 0.1  |
| 60            | 87.0                   | 5.0                     | 82.0                  | 14            | 1.5                         | 5                  | 0.1  |

Test # 47

Grade - 535  
 Weight - 4 oz/ft<sup>2</sup>  
 Influent - Coagulated Water  
 Temperature of influent - 14.5°C  
 Turbidity of raw water - 25

pH of influent - not determined  
 pH of effluent - not determined  
 Color of influent - not determined  
 Color of effluent - not determined  
 Clear - not determined

| Time<br>(min) | Input<br>Head<br>(psi) | Output<br>Head<br>(psi) | Loss<br>Head<br>(psi) | Rate<br>(gpm) | Rate<br>gpm/ft <sup>2</sup> | Turbidity<br>(ppm) |      |
|---------------|------------------------|-------------------------|-----------------------|---------------|-----------------------------|--------------------|------|
|               |                        |                         |                       |               |                             | Inf.               | Eff. |
| 0             | 24.0                   | 9.0                     | 15.0                  | 50            | 5.6                         | 5                  | 0.1  |
| 15            | 60.0                   | 7.5                     | 52.5                  | 42            | 4.7                         | 5                  | 0.1  |
| 30            | 83.0                   | 6.0                     | 77.0                  | 24            | 2.7                         | 5                  | 0.1  |
| 45            | 86.0                   | 5.0                     | 81.0                  | 18            | 2.0                         | 5                  | 0.1  |
| 60            | 87.0                   | 5.0                     | 82.0                  | 17            | 1.9                         | 5                  | 0.1  |

Test # 48

Grade - Hyflo Super-Cel  
 Weight - 3/8 oz/ft<sup>2</sup>  
 Influent - Coagulated Water  
 Temperature of influent - 14°C  
 Turbidity of coagulated water - 8

pH of influent - not determined  
 pH of effluent - not determined  
 Color of influent - not determined  
 Color of effluent - not determined  
 Clear - 180 seconds

| Time<br>(min) | Input<br>Head<br>(psi) | Output<br>Head<br>(psi) | Loss<br>Head<br>(psi) | Rate<br>(gpm) | Rate<br>gpm/ft <sup>2</sup> | Turbidity<br>(ppm) |      |
|---------------|------------------------|-------------------------|-----------------------|---------------|-----------------------------|--------------------|------|
|               |                        |                         |                       |               |                             | Inf.               | Eff. |
| 0             | 38.0                   | 7.5                     | 30.5                  | 45            | 5.0                         | 8                  | 2.0  |
| 15            | 84.0                   | 6.0                     | 78.0                  | 20            | 2.2                         | 8                  | 3.0  |
| 30            | 87.0                   | 5.0                     | 82.0                  | 14            | 1.5                         | 8                  | 3.0  |
| 45            | 88.0                   | 5.0                     | 83.0                  | 11            | 1.2                         | 8                  | 3.5  |
| 60            | 89.0                   | 5.0                     | 84.0                  | 10            | 1.1                         | 8                  | 3.5  |

PART II

## Bacteriological Data

Test A (Unsettled and Unchlorinated)

Grade - Celite No. 512

Weight - 5.33 oz/ft<sup>2</sup>

Coliform Confirmed (5-10 ml. portions planted)

|                | <u>Influent</u> | <u>Effluent</u> |
|----------------|-----------------|-----------------|
| Test cycle # 1 | 5/5             | 2/5             |
| Test cycle # 2 | 5/5             | 1/5             |
| Test cycle # 3 | 4/5             | 2/5             |

37° Standard Agar Plate Count (1 ml. placed)

|                | <u>Influent</u> | <u>Effluent</u> |
|----------------|-----------------|-----------------|
| Test cycle # 1 | 203             | 10              |
| Test cycle # 2 | 275             | 5               |
| Test cycle # 3 | 308             | 12              |

Test B (Settled and Unchlorinated)

Grade - Celite No. 512

Weight -  $\frac{1}{2}$  oz/ft<sup>2</sup>

Coliform Confirmed (5-10 ml. portions planted)

|                | <u>Raw</u> | <u>Settled Influent</u> | <u>Effluent</u> |
|----------------|------------|-------------------------|-----------------|
| Test cycle # 1 | 5/5        | 1/5                     | 0/5             |
| Test cycle # 2 | 4/5        | 2/5                     | 0/5             |
| Test cycle # 3 | ---        | 2/5                     | 0/5             |

37° Standard Agar Plate Count (1 ml. placed)

|                | <u>Raw</u> | <u>Settled Influent</u> | <u>Effluent</u> |
|----------------|------------|-------------------------|-----------------|
| Test cycle # 1 | 310        | 80                      | 1               |
| Test cycle # 2 | ---        | 95                      | 0               |
| Test cycle # 3 | ---        | 110                     | 2               |

Test C (Settled and Unchlorinated)

Grade - Hyflo Super-Cel

Weight -  $\frac{1}{2}$  oz/ft<sup>2</sup>

Coliform Confirmed (5-10 ml. portions planted)

|                | <u>Raw</u> | <u>Settled Influent</u> | <u>Effluent</u> |
|----------------|------------|-------------------------|-----------------|
| Test cycle # 1 | 5/5        | 1/5                     | 0/5             |
| Test cycle # 2 | ---        | 0/0                     | 0/5             |
| Test cycle # 3 | ---        | 3/5                     | 1/5             |

37° Standard Agar Plate Count (1. ml. placed)

|                | <u>Raw</u> | <u>Settled Influent</u> | <u>Effluent</u> |
|----------------|------------|-------------------------|-----------------|
| Test cycle # 1 | 250        | 51                      | 2               |
| Test cycle # 2 | ---        | 76                      | 1               |
| Test cycle # 3 | ---        | 53                      | 0               |

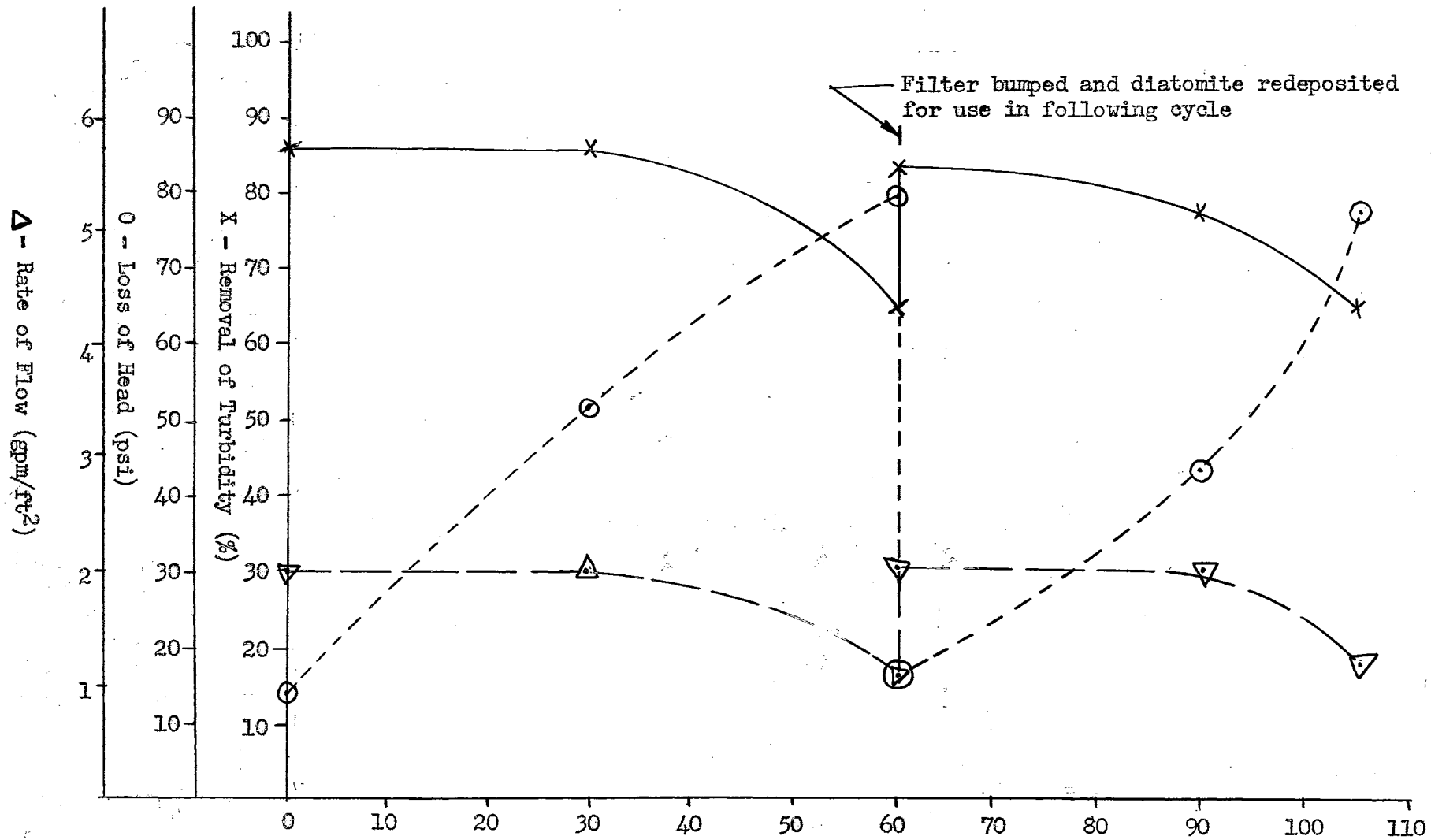

Figure 15. Characteristics of Diatomite Filtration During Test # 15.



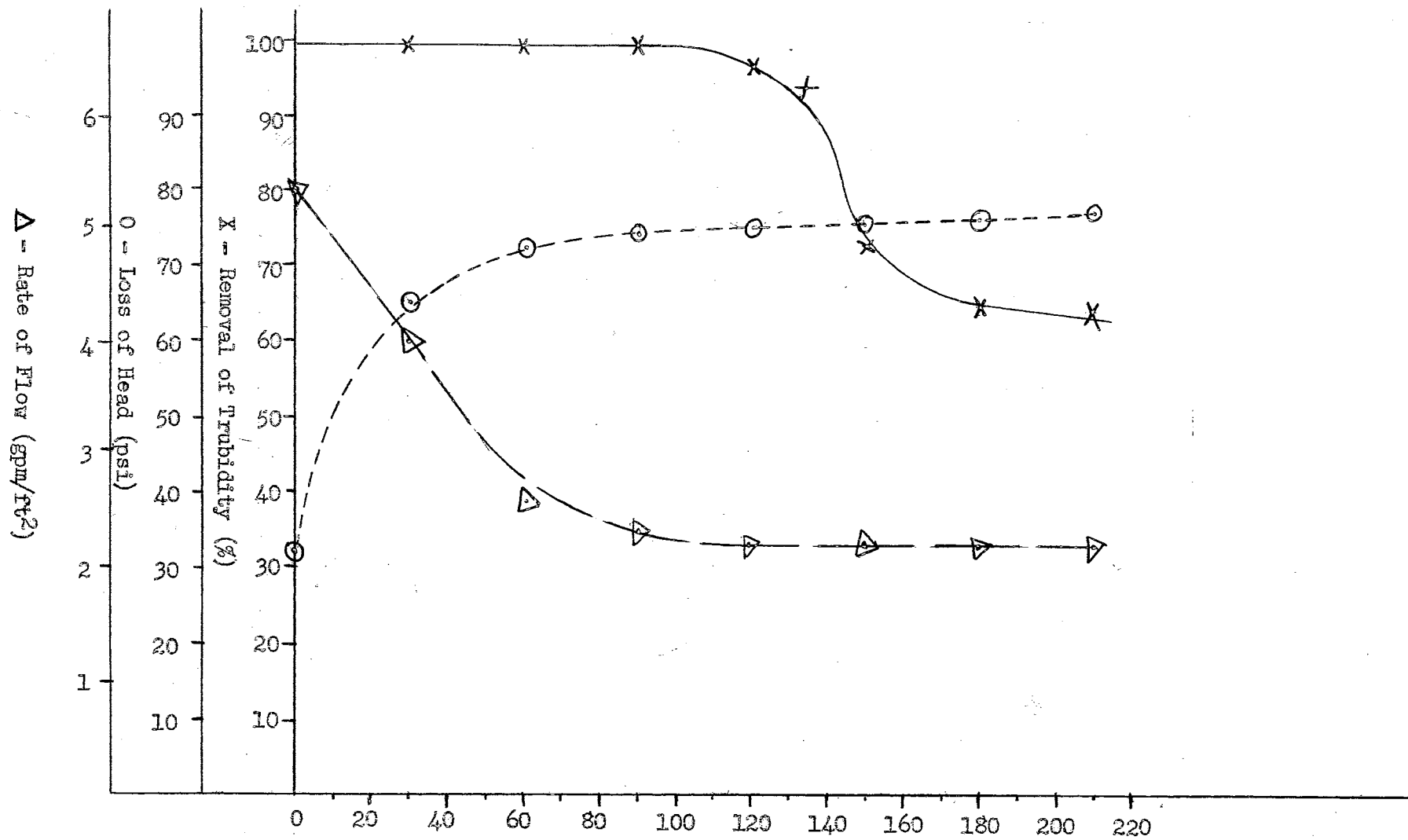

Figure 16. Characteristics of Diatomite Filtration During Test # 30.

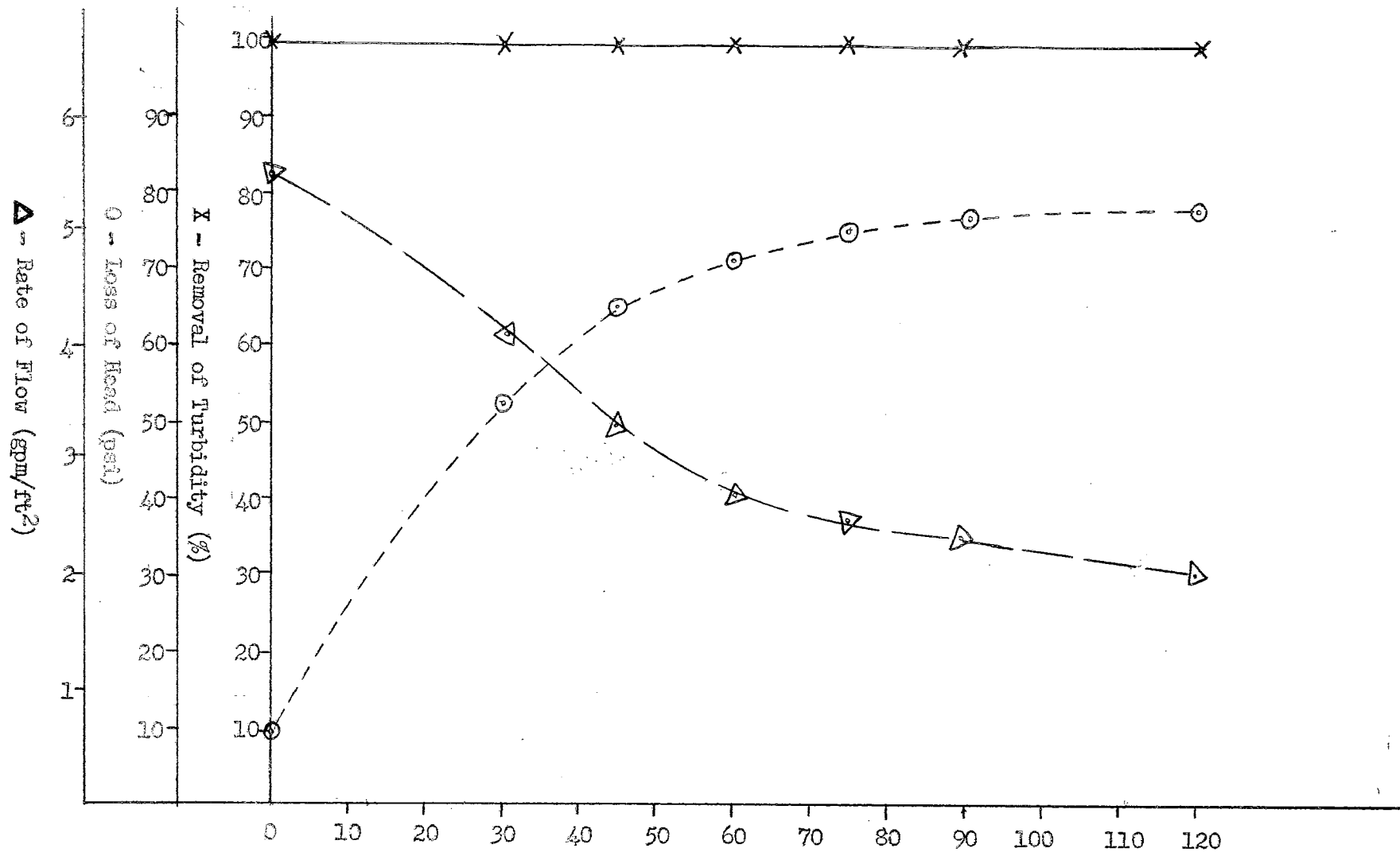

Figure 17. Characteristics of Diatomite Filtration During Test # 38.

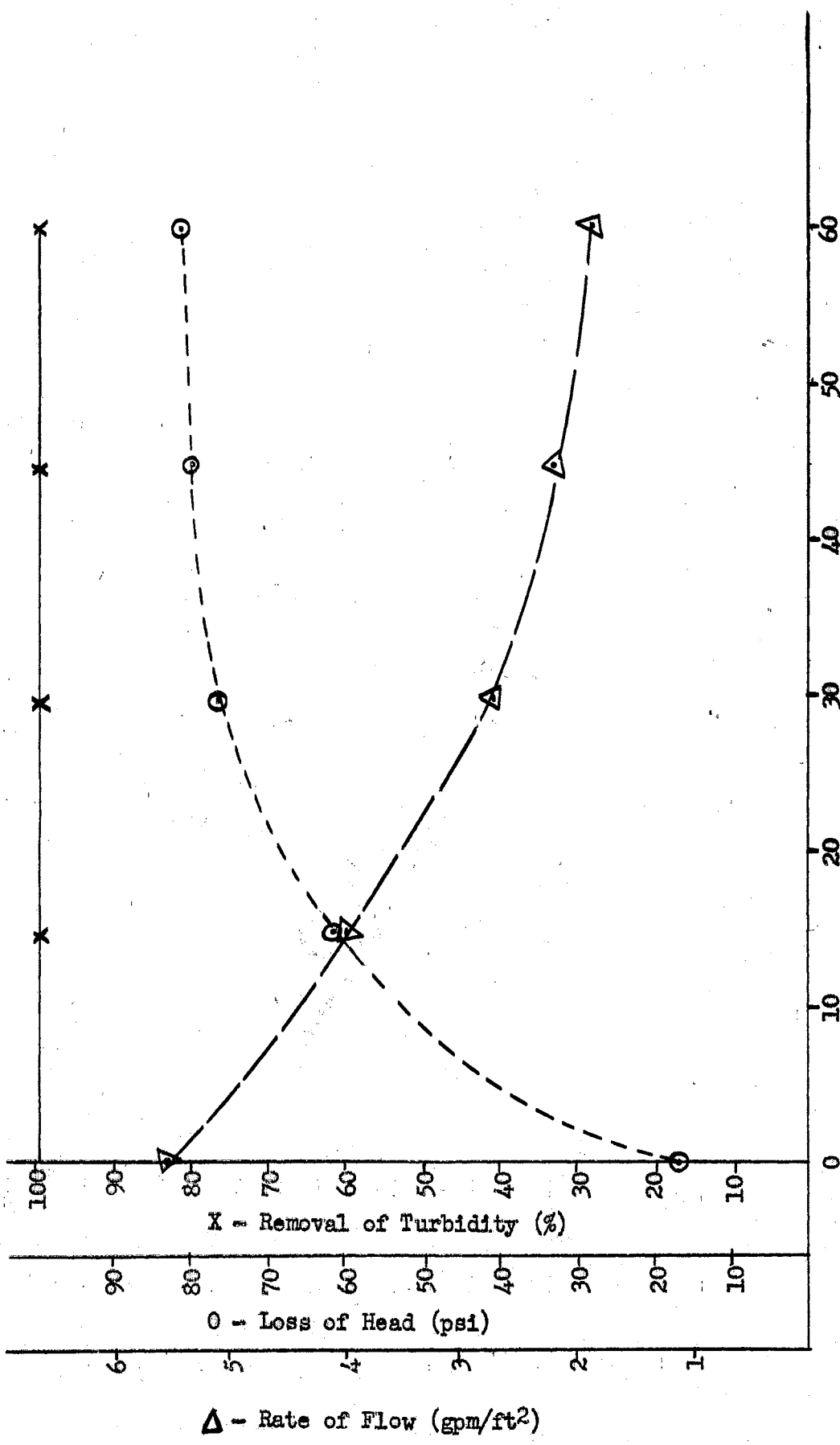

Figure 18. Characteristics of Diatomite Filtration During Test # 40.

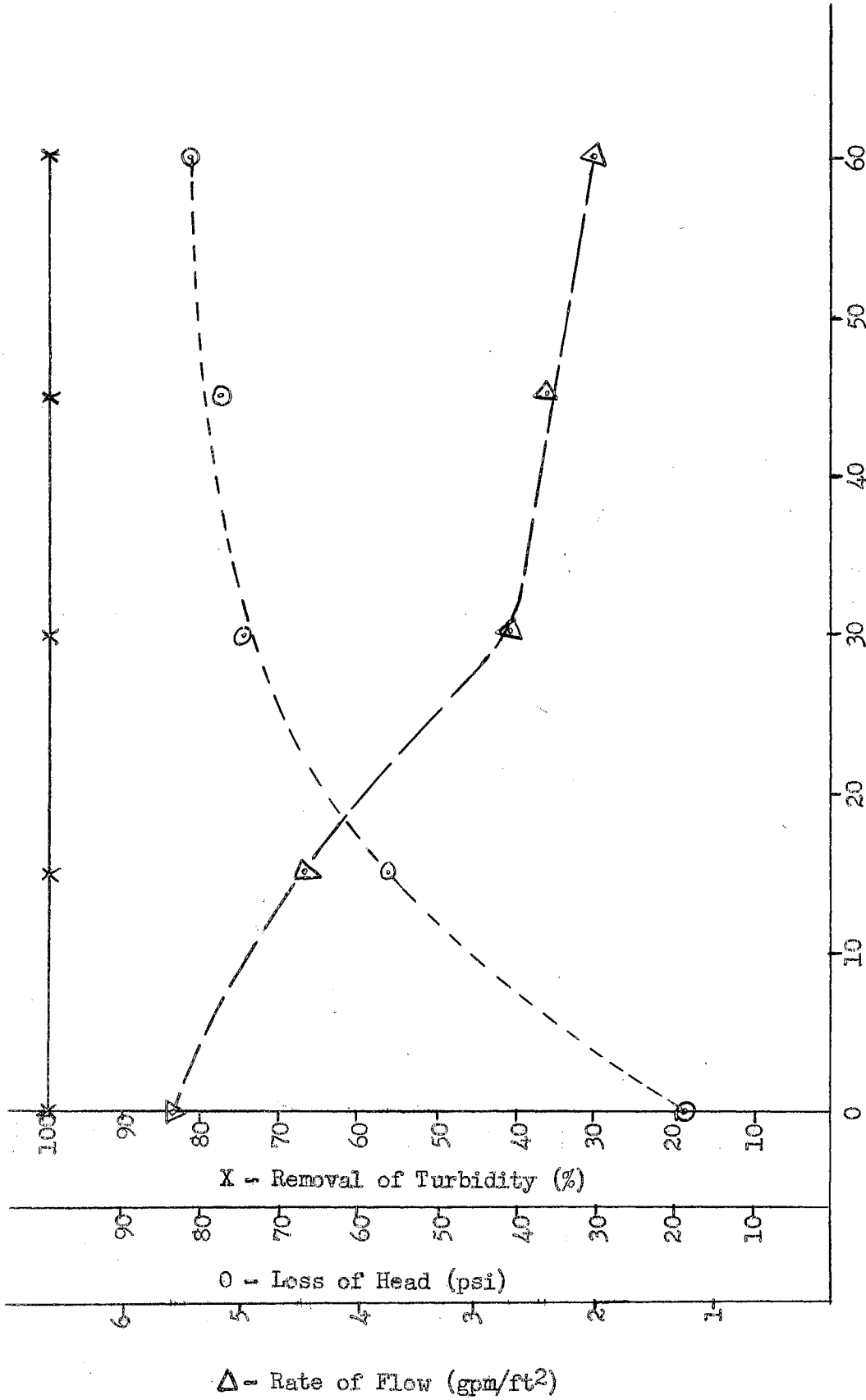

Figure 19. Characteristics of Diatomite Filtration During Test # 43.

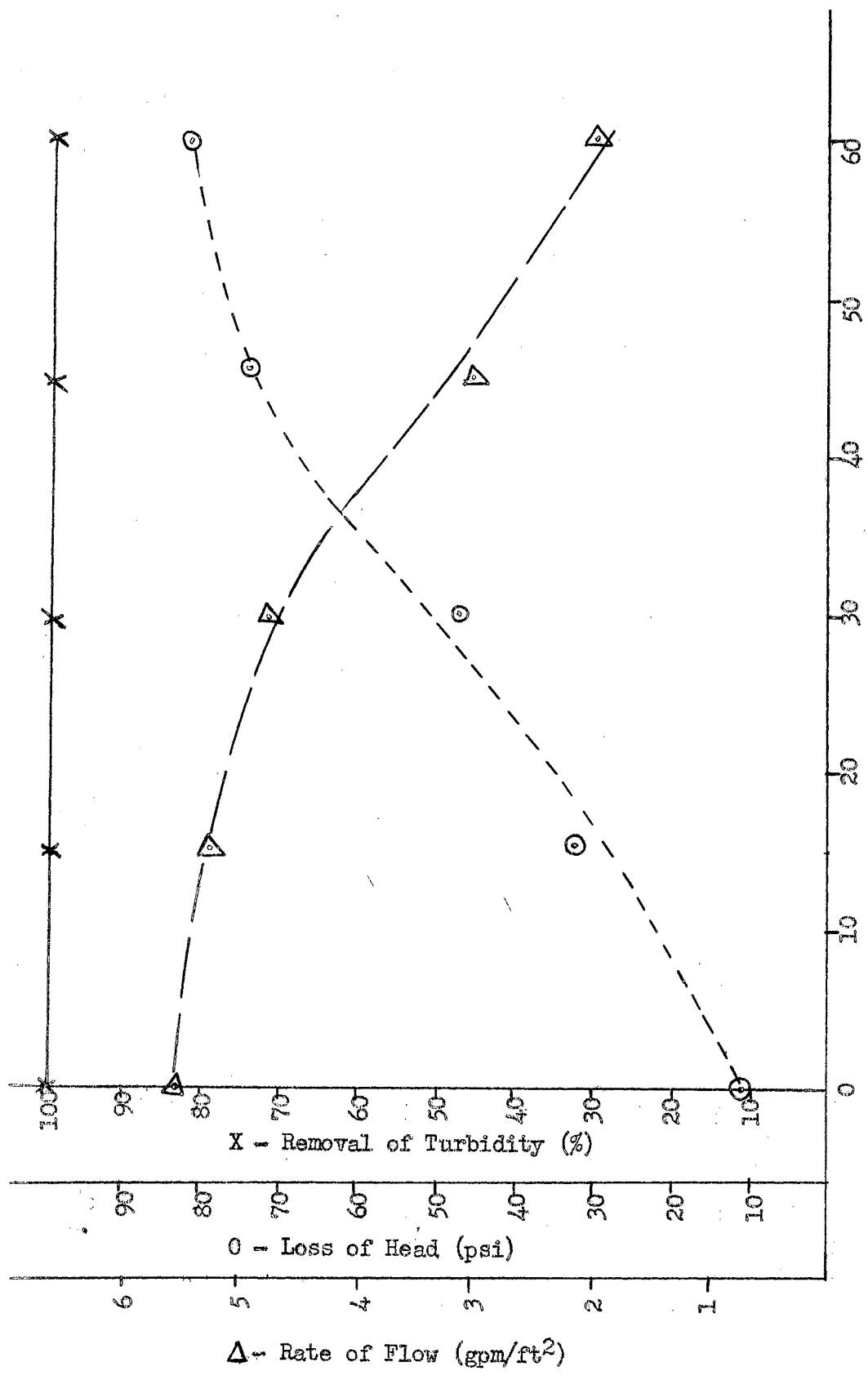

Figure 20. Characteristics of Diatomite Filtration During Test # 45.

## CHAPTER VIII

## SUMMARY

The study of the effectiveness of diatomaceous earth filters on Lake Carl Blackwell water was divided into three distinct phases.

The first phase investigated the ability of the filter to deliver, at high rates, a satisfactory effluent practically free from turbidity when the influent was raw, unsettled surface water, having moderate turbidity. The color and the hydrogen-ion concentration were determined on several tests before and after the water passed through the diatomite filter. This provided a general indication as to the ability of the diatomite to affect these properties. Diatomaceous earths of various grades were studied and it was decided that the desired comparative data, concerning each grade of diatomite, could best be obtained by varying the following factors:

1. The grade of diatomite used for precoating.
2. The weight of each grade used per unit area of filter surface.
3. The rate of flow through the filter. In testing most of the raw water, the flow rate was maintained at some predetermined figure.

However, in a few tests of raw water, all efforts were made to obtain the maximum rate of flow at the beginning of the filter cycle.

Phase two followed the plan and purpose stated in phase one in every respect except that phase two used as an influent water that had been coagulated with aluminum sulphate (alum), softened with calcium hydroxide (lime) and then settled. One other variation from the plan as stated in phase one existed in the rate of flow. The rate of flow in phase two was raised to a maximum as soon as possible after the precoat was deposited on the filter element.

Phase three consisted of the bacteriological examination of the effluent

from the diatomite grade-weight variations that gave the most satisfactory results in phase one and in phase two.

The results of the study indicated that satisfactory effluents could be obtained from untreated water when the proper grade-weight combinations were found and that even better effluents could be expected when the influent was settled water. The rates of flow per unit area of filter surface did not greatly exceed those rates proposed for rapid sand filters and after a few hours of operation the rates obtained with diatomite filtration fell below the standard rates of rapid sand filtration. Yet, the head loss through the diatomite filter greatly exceeded the head loss which might be expected through the rapid sand filter. It was indicated by the data that no color was removed as the water passed through the filter nor was the hydrogen-ion concentration changed. The results of the bacteriological tests inferred that bacteria in general are greatly reduced or in some cases presumably eliminated from the water as it passes through the filter.

CHAPTER IX  
DISCUSSION AND CONCLUSION

The over-all effectiveness of the diatomite filter decreased as the filtering cycle progressed. This loss of effectiveness was observed when treating either raw or coagulated water and when using all grades of diatomite. There were three manifestations of the loss of effectiveness which were particularly noted in these tests. Test # 30 is an example of the tests in which all three occurred in the same test; that is there was a decrease in the effluent flow rate, an increase in the head loss across the filter, and a decrease in the per cent of original turbidity removed, as indicated by the data. Test # 38 on the other hand indicates the occurrence of only the first two manifestations during the period that data was recorded.

The effective initial percent removal of turbidity from raw water increased as the fineness of the grade of diatomite increased; but this increase in percent removal of turbidity was gained only through a corresponding loss of head and loss of long term effectiveness. A comparative analysis of the data obtained during tests # 15 and # 21 is indicative of the manner in which fineness affects the three criteria of filter operation. Both tests used raw water having the same initial turbidity and the same weight of diatomite precoat. At the end of a thirty minute period the fine grade of diatomite maintained its high percent removal of turbidity, but the head loss was almost three times that of the coarse grade of diatomite. At the end of a sixty minute period the fine grade was removing approximately 65 per cent of the original raw water turbidity while the coarse grade was removing about 70 per cent. The head loss with the fine grade was more than twice the head loss with the coarse grade. The rate of flow of the finer grade had dropped from 2.0 gallons per square foot per minute to 1.1 gallons per square foot per minute while the rate of



flow of the coarse grade remained constant at 2.0 gallons per square foot per minute. The general trend of most tests on raw water followed the results of test # 21 and test # 15.

Due to the nature of the turbidity, no satisfactory results were obtained from tests of Celite No. 545 between the limits of 1.77 ounces per square foot and 5.33 ounces per square foot.

The tests on raw water represented by the data from test # 4, # 10, # 14 and # 21 indicate that an optimum grade-weight combination exists, and that increasing the weight of diatomite used per square foot of filter surface only tends to decrease the effectiveness of the filter. Test # 10 using a precoat of 4.44 ounces of Hyflo Super-Cel removed 83 percent of the turbidity at the start of a 60 minute cycle while at the end of the cycle it removed 79 percent of the turbidity. In test # 14 a precoat of the same grade of diatomite was used but the weight was increased to 5.33 ounces per square foot. This grade-weight combination removed only 79 percent of the turbidity at the beginning of the cycle and only 75 percent at the end of the cycle. No appreciable decrease in the original turbidity was noted in test # 4 using 1.77 ounces of Hyflo Super-Cel. Test # 21 used the same grade and weight of diatomite as test # 14 and filtered a water having less turbidity than the water of test # 14 but still gave overall results inferior to those of test # 10. The conclusions reached from the analysis of these four tests would indicate that the optimum grade-weight combination existed in a range close to that used in test # 10. Similar conclusions can be deduced from other test data.

Test # 15 using 5.33 ounces of Celite No. 512 per square foot was considered to give the best short term results on raw water since the grade-weight combination used in this test gave effective removal of turbidity along with a fair rate of flow for a period of 30 minutes. Grade-weight combinations in the range of those used in test # 7 would be of greatest value when the turbidity

of the effluent could be allowed to reach 10 parts per million and a longer length of run was desired. Test # 7 used 3.55 ounces of Celite No. 501 per square foot and continued to deliver an effluent of less than 10 parts per million turbidity for a period of 210 minutes at a rate of 2 gallons per square foot per minute. The advantages of the combination used in test # 7 are obvious in view of an emergency when allowable maximum turbidity might be desired in order to utilize the longer cycle with a corresponding greater volume of filtered water.

Tests #16 and # 17 introduced information that demonstrates how quickly the diatomite filter became clogged when the turbidity of the influent raw water rose above 50 parts per million. The affect that body feed would have on waters having turbidities in this range remains a problem for further study. It is believed that with waters containing high turbidities, plain sedimentation previous to filtration might prove quite worthwhile when using the diatomite filter. These investigations were beyond the scope of this thesis.

The results from the five grades of diatomite tested on coagulated water indicated that the most satisfactory results were obtained when the weight of diatomite charge per square foot of filter surface varied between  $\frac{1}{2}$  ounce and 4 ounces. Of the five most satisfactory grade-weight combinations, studied, test # 30 using  $\frac{1}{2}$  ounce of Celite No. 512 per square foot and test # 43 using  $\frac{1}{2}$  ounce of Hyflo Super-Cel per square foot seemed to be the best grade-weight combinations to use in filtering Lake Carl Blackwell water. The highest rate of flow was obtained in test # 45 using 3 ounces of Celite No. 535 per square foot, but this test was not studied further because the amount of diatomite used was six times that used in tests # 30 and # 43. The choice as to whether or not the extra amount of diatomite used in test # 45 is warranted in view of the higher rate of flow was considered to be a problem dependent on local

factors and beyond discussion in this paper.

The theory of the optimum grade-weight combination expressed in relationship to filtering raw water also seems to hold true for coagulated water even though the nature of the turbidity, due to the presence of chemical precipitates, is quite different. The series of tests made on a coagulated water using Celite No. 535 as a precoat demonstrates most clearly the relationship between the grade-weight combination and effectiveness. The few noted exceptions to the optimum grade-weight combination idea could probably be explained in terms of the difference in nature and quantity of the turbidity.

The filter cycles in which the diatomite was used, bumped from the element then redeposited for use in a subsequent cycle indicated plainly that additional use can be made of the diatomite but a decrease in its effectiveness is likewise evident. The Hydrogen-ion concentration and the color of the water seemed to remain unchanged by the filtration process.

The bacteriological tests indicate that bacteria in general are greatly reduced or in some cases presumptively eliminated from the water during the filtering process. The tests on raw water are inconclusive but seem to bear out this conclusion. The coagulated water for all bacteriological testing was first processed through the Accelerator as manufactured by Infilco, Inc.. The results of confirmed coliform tests show from 50% to 80% decrease in activity following coagulation. A further decrease in coliform activity was observed following the diatomite filtration. It must be realized that the bacteriological tests made in this study were by no means exhaustive and were used only to ascertain a trend. Sterilization of water is not the primary function of the filter. All potable supplies of water should be properly chlorinated to render them as safe as possible.

The results of this study would seem to eliminate the possibility of the

diatomite filter, without body feed, replacing the rapid sand filter. The lengths of diatomite filter cycles for settled water are far below the 18 to 24 hour periods used for rapid sand filters operated in the plant where the tests for this study were conducted. The sand filter runs were made at the same time the diatomite filter runs were made and with water from the same coagulating basins.

In summarizing the conclusions of this work, it would appear correct to state that the diatomite filter without body feed has a definite place in emergency filtration of both settled and unsettled water. Any diatomite filter operator having a knowledge of the characteristics of weight-grade combinations and their relationship to the filtering process would be able to deliver a satisfactory effluent in an economical manner. The time it takes to make a proper study of a given water is the best argument for investigations of possible emergency water sources before the actual need arises. The fact that the filter does reduce the load of microorganisms is evident in the data from this work and in the data from the work of others cited in this thesis.

The diatomaceous earth filter is effective in the filtration of both unsettled and settled Lake Carl Blackwell water.

## BIBLIOGRAPHY

- American Public Health Association and American Water Works Association, Standard Methods for the Examination of Water and Sewage. New York: American Public Health Association, 1946. 286 pp.
- American Society of Civil Engineers, Manuals of Engineering Practice - No. 19, Water Treatment Plant Design. New York: Headquarters of the Society, 1940. 128 pp.
- Applebaum, S. B., "Filtration of Water Through Diatomaceous Earth," Water and Sewage Works, XCIII (August, 1946), 308-10.
- Babbitt, Harold E. and Doland, James J., Water Supply Engineering. New York: McGraw-Hill Book Company, 1949. 637 pp.
- Baker, Moses Nelson, The Quest for Pure Water. New York: American Water Works Association, 1948. 527 pp.
- Baylis, John R., "Are We Ready for High-Rate Filtration of Water?" Water and Sewage Works, XCVII (November, 1950), 456-58.
- Black, Hayse H. and Spaulding, Charles H., "Diatomite Water Filtration Developed for Field Troops," Journal American Water Works Association, XXXVI (November, 1944), 1208-21.
- "Celite Filter-Aids and Mineral Fillers," Johns-Manville DS Series 450. New York: Johns-Manville, 1943. 10 pp.
- Chang, S. L. and Fair, Gordon M., "Viability and Destruction of the Cysts Endameba histolytica," Journal American Water Works Association, XXXIII (October, 1941).
- Cummins, A. B., "Clarifying Efficiency of Diatomaceous Filter Aids," Industrial and Engineering Chemistry, XXXIV (April, 1942), 403-11.
- "Dicalite Diatomaceous Aids to Industry," Technical Service Bulletin, No. B-12. New York: Great Lakes Carbon Corp., 1949. 12 pp.
- Dunham, George C., Military Preventive Medicine. Harrisburg: Military Service Publishing Company, 1940. 1198 pp.
- Elsenbast, A. S. and Morris, D. C., "Diatomaceous Silica Filter-Aid Clarification," Industrial and Engineering Chemistry, XXXIV (April, 1942), 412-18.
- Great Lakes Carbon Corporation, Dicalite Aids to Industry. New York: Great Lakes Carbon Corp., 1947. 27 pp.
- Kiker Jr., John E., "Diatomite Filters for Swimming Pools," Journal American Water Works Association, XLI (September, 1949), 801-09.

Operating Directions for the Model 14 Coleman Universal Spectrophotometer.

Maywood: Coleman Instruments Inc., 1947. 39 pp.

Rosenau, Milton J., Preventive Medicine and Hygiene. New York: Appleton-Century-Crofts, Inc., 1940. 1481 pp.

Turneaure, F. E. and Russell, H. L., Public Water Supplies. New York: John Wiley and Sons, Inc., 1940. 704 pp.

Whipple, George C. and Fair, Gordon M., The Microscopy of Drinking Water. New York: John Wiley and Sons, Inc., 1941. 585 pp.

THESIS TITLE: The Effectiveness of Diatomaceous Earth Filters  
on Lake Carl Blackwell Water

NAME OF AUTHOR: Warren E. Hoxworth

THESIS ADVISER: Quintin E. Graves

The content and form have been checked and approved by the author and thesis adviser. "Instructions for Typing and Arranging the Thesis" are available in the Graduate School office. Changes or corrections in the thesis are not made by the Graduate School office or by any committee. The copies are sent to the bindery just as they are approved by the author and faculty adviser.

NAME OF TYPIST: Fern B. Hall