

ASSESSING HORIZONTALLY-ORIENTED  
ACOUSTIC METHODS FOR GIZZARD SHAD  
ABUNDANCE ASSESSMENTS: ACCURACY,  
PRECISION AND TARGET ORIENTATION

By

GARRETT JOHNSON

Bachelor of Science in Fisheries and Water Resources

University of Wisconsin-Stevens Point

Stevens Point, Wisconsin

2015

Submitted to the Faculty of the  
Graduate College of the  
Oklahoma State University  
in partial fulfillment of  
the requirements for  
the Degree of  
MASTER OF SCIENCE  
December, 2017

ASSESSING HORIZONTALLY-ORIENTED  
ACOUSTIC METHODS FOR GIZZARD SHAD  
ABUNDANCE ASSESSMENTS: ACCURACY,  
PRECISION AND TARGET ORIENTATION

Thesis Approved:

Dr. Daniel Shoup

---

Thesis Adviser

Dr. Kevin Boswell

---

Dr. James Long

---

## ACKNOWLEDGEMENTS

I would like to thank my advisor Dr. Daniel Shoup and my committee members Dr. James Long and Dr. Kevin Boswell for their guidance throughout the project.

I would also like to thank the Oklahoma Department of Wildlife Conservation for their fiscal contributions to the research. Their contributions funded hydroacoustic equipment rental and other project materials making the project possible.

I would like to express my gratitude to the Marine Ecology and Acoustics Lab at Florida International University and its members for providing hydroacoustic equipment and technical support throughout the project.

Lastly, many thanks to fellow graduate students, undergraduates and technicians that have assisted throughout the project. Your help throughout the project was invaluable and it must have been difficult spending extended periods of time stuck on a boat with me.

Name: GARRETT JOHNSON

Date of Degree: DECEMBER, 2017

Title of Study: ASSESSING HORIZONTALLY-ORIENTED ACOUSTIC METHODS FOR GIZZARD SHAD ABUNDANCE ASSESSMENTS: ACCURACY, PRECISION AND TARGET ORIENTATION

Major Field: Natural Resource Ecology and Management

Abstract: Gizzard Shad (*Dorosoma cepedianum*) are an important prey species that are commonly sampled with gill nets. However, horizontally-oriented methodologies have the potential to produce better Gizzard Shad data with less effort. Before horizontal beaming can be used as a sampling gear for Gizzard Shad, accuracy and precision need to be examined to determine if this approach provides reliable and consistent data. Further, Gizzard Shad-specific relationships between acoustic target strength (TS) and total length (TL) should be derived to ensure density estimates are accurate. I tested the accuracy and precision of horizontal beaming by sampling known populations of Gizzard Shad in a net pen (15-m long x 15-m wide x 4.5-m deep with 6.35-mm square mesh). I found horizontal beaming accurately detected changes in density ( $R^2=0.63$ ) with increased precision (mean CV of 6% among all trials) than other gears used to sample Gizzard Shad. Given that TS changes with fish orientation, I developed an orientation-based TS-TL equation to increase accuracy of hydroacoustic estimates. A catenary (U-Shape) function was best at representing the change in TS at different fish orientations (conditional  $R^2 = 0.71$  and marginal  $R^2 = 0.67$ ). I also compared echo integration results using six different TS-TL equations (2 from this paper and 4 from previous literature) using 23 fish aggregations imaged in the field. Equation choice had a significant effect on density estimates ( $P<0.01$ ) indicating care should be taken when selecting TS-TL equations for use in hydroacoustic surveys.

## TABLE OF CONTENTS

Chapter	Page
I. Literature Review .....	1
References .....	5
II. Accuracy and Precision of Hydroacoustic Estimates of Gizzard Shad Abundance Using orizontal Beaming .....	9
Abstract .....	9
Introduction .....	10
Methods .....	13
Results .....	15
Discussion .....	15
References .....	18
Tables .....	23
Figures .....	25
III. HORIZONTAL-ASPECT TARGET-STRENGTH EQUATIONS FOR GIZZARD SHAD DOROSOMA CEPEDIANUM: INCORPORATING FISH ORIENTATION INTO TARGET STRENGTH-TOTAL LENGTH EQUATIONS .....	28
Abstract .....	28
Introduction .....	29
Methods .....	32
Field test of TS-TL equation .....	35
Comparison of echo-integration results applying different side-aspect TS-TL equations .....	36
Results .....	37
Field test of TS-TL equation .....	37
Comparison of echo-integration results applying different side-aspect TS-TL equations .....	37
Discussion .....	38
References .....	42
Tables .....	46
Figures .....	50

## LIST OF TABLES

Table	Page
1. Trial number, net set, abundance and density for each net pen (15-m long x 15-m wide x 4.5-m deep) trial to evaluate Gizzard Shad ( <i>Dorosoma cepedianum</i> ) density estimation with a horizontally-oriented echosounder.....	23
2. Echosounder, transducer and analysis parameters used during data collection and analyses for net pen trials with Gizzard Shad. ....	24
3. Echosounder, transducer and analysis thresholds used in target strength experiments for Gizzard Shad.....	46
4. Names and equations that were compared for estimating target strength using orientation and total length information where TS is estimated target strength, TL is total length in mm, sin is sine, cos is cosine, cosh is hyperbolic cosine, and $\theta$ is orientation of the ensonified fish in radians. Other symbols are constants fit by maximum likelihood. ....	47
5. Data collection and analysis thresholds for schools observed during drift surveys in Lake Carl Blackwell, Stillwater, Oklahoma. ....	48
6. Names and sources for target strength versus total length equations compared by echo integrating individual schools. ....	48

7. Regression Coefficients for target strength equations ( $TS = a * \log_{10}(TL) + b$  for length,  $TS = a * \log_{10}(WT) + b$  for weight) derived from ex situ tank experiments for Gizzard Shad (*Dorosoma cepedianum* (n=47, 64-321 mm, 3-223.8 g) at different orientations (Head-on fit data where fish were facing the transducer [90°], Lateral fit data where fish were perpendicular to the transducer [0° and 180°], and Mean fit data from all fish orientations (0 – 180° in 5° increments).  $b_{20}$ -values are from models using a slope fixed at  $a=20$  (Foote 1987). P-value indicates whether slope was significantly different than 1. An asterisk denotes the parameter was statistically different between the two forms of the TS-TL equation..... 49
8. Comparisons of model fits for 8 orientation-based and 1 non-orientation based models for Gizzard Shad data collected in tank experiments. .... 49

## LIST OF FIGURES

Figure	Page
1. Plan-view diagram depicting the net pen used to test the accuracy and precision of Gizzard Shad abundance using hydroacoustic sampling. ....	25
2. Regression line (dashed line) depicting the change in estimated density (fish/m <sup>3</sup> ) at different known fish densities measured with a horizontally-oriented echosounder. Shaded area represents the 95% confidence interval of the slope; solid line is the 1: 1 slope line that would indicate complete accuracy.....	26
3. Coefficient of variation (SE/mean) for hydroacoustic density estimates measured at different known Gizzard Shad densities in net pen trials. Coefficients of variation are based on 5 replicate passes of the net with the same fish assemblage. ....	27
4. Diagram depicting setup of transducer and tethered fish within pool for ex situ hydroacoustic target strength measurements of Gizzard Shad. ....	50
5. Example of target strength values at orientations ranging from 0-180 degrees (0 and 180 being lateral and 90 being head-on perspective) in 5 degree increments for a 267 mm Gizzard Shad from ex situ experiments. ....	51
6. Figure 6. Diagram of fish orientations within acoustic beam. Depicted fish is at an orientation of approximately 35 degrees (oblique category) .....	52
7. Target strength frequency for Gizzard Shad (n=47,64-321 mm, 3-223.8 g) at orientations from 0-180 degrees (0 and 180 being lateral and 90 being head-on perspective) measured ex situ tank trials. ....	53



Figure	Page
8. Distributions of TS measurements for Gizzard Shad in the 76-100 mm (n=5 fish, 185 measurements) and 251-275 mm (n=5 fish, 185 measurements) length bins at orientations from 0-180 degrees measured in ex situ tank trials illustrating overlap of measured target strength of large and small Gizzard Shad. ....	54
9. Total length to target strength regressions for lateral aspect, head/tail aspect and average of all orientations allowing the a-coefficient to vary (Basic) and fixing it at 20 (Foote 1987b) for Gizzard Shad (n=47, 64-321 mm, 3-223.8 g). ....	55
10. Raw data and modelled catenary equation for a 142 mm (a) and 267 mm (b) Gizzard Shad from data collected in tank trials.....	56
11. Depiction of the change in expected target strength with changes in total length and orientation modelled using a catenary function derived from data collected from Gizzard Shad in tank trials .....	57
12. Difference between measured target strength from a Simrad EK60 120 kHz transducer and estimated target strength derived from length and orientation data collected with an ARIS imaging SONAR using my catenary equation.....	58
13. Comparison Comparison of mean school density from 23 schools estimated using six different horizontal-aspect TS-TL equations. In addition to a non-orientation based mean TS-TL equations with random intercept (JohnALL) and a variant with slope fixed at 20 (JohnsFoote) from the current study, I tested Boswell and Wilson (2008) equations from pooled data for Gulf Menhaden ( <i>Brevoortia patronus</i> ) and Bay Anchovy ( <i>Anchoa mitchilli</i> ; BosPooled; BosFoote), Frouzova's (2005) European pooled freshwater fish equation (FrouPooled), and Kubecka's (1994) brown trout ( <i>Salmo trutta</i> ) model (KubALL). ....	59

## CHAPTER I

### LITERATURE REVIEW

Gizzard Shad (*Dorosoma cepedianum*) are an important prey species in lakes and reservoirs throughout southern and mid-latitudes of the United States, and routinely have the highest density and largest biomass of all prey types within these systems (Miranda 1983; Carline et al. 1984; Johnson et al. 1988). High age-0 Gizzard Shad density can increase growth rates of piscivorous fish, leading to increased winter survival (Stahl et al. 1996; Michaletz 1998; Allen et al. 1999) and ultimately larger harvestable populations. In many aquatic systems, piscivore populations are supplemented or maintained by stocking (Boxrucker 1986; Terre et al. 1993), providing an opportunity to use information about juvenile Gizzard Shad abundance to determine appropriate stocking numbers for sportfishes (Donovan et al. 1997). However, this will only work if estimates of prey abundance are accurate (Donovan et al. 1997). If Gizzard Shad abundance is over-estimated, erroneously high stocking rates for predators could result in depleted prey populations and poor survival of stocked fish due to density-dependent growth and resultant mortality (Post et al. 1997). Conversely, if Gizzard Shad abundance is under estimated, erroneously low stocking rates for predators could lead to an over-abundant Gizzard Shad population with a large size-structure, which can compete with larval sportfish that feed on zooplankton (Roseman et al. 1996). Further, Gizzard Shad populations with large size-structure typically exhibit low reproduction, thus decreasing available prey for juvenile sportfish (Sammons et al. 1998; Schramm et al. 1999; Ostrand et al. 2001). Therefore, accurately estimating age-0 Gizzard Shad abundance is critical to effective and sustainable piscivore management.

Currently, gill nets are the most common gear used to collect Gizzard Shad population characteristics, but hydroacoustics have the potential to produce better data with less effort. Gillnet-derived estimates of Gizzard Shad abundance can be time and labor intensive, lack precision, and may lack accuracy (Van Den Avyle et al. 1995a; Van Den Avyle et al. 1995b). Hydroacoustic sampling has potential to provide precise estimates of pelagic prey fish abundance with reduced time and effort (Van Den Avyle et al. 1995a; Taylor et al. 2005; Taylor and Maxwell 2007). For example, surface-set gill nets take seven times more person-hours than hydroacoustics to collect sufficient samples to detect a 25% difference in mean catch rates of Gizzard Shad (includes data processing time for hydroacoustics; Van Den Avyle et al. 1995a). Therefore, sampling Gizzard Shad populations with hydroacoustics would result in reduced time and effort to acquire Gizzard shad population characteristics (Van Den Avyle et al. 1995a; Dennerline et al. 2012).

Traditional hydroacoustic sampling procedures utilize a transducer oriented vertically, beaming straight down or at a slight angle (Vondracek and Degan 1995; Stanley and Wilson 2000; Boswell et al. 2010), but this approach can be ineffective in shallow water for several reasons. First, data collected in the nearfield of the transducer is inaccurate and needs to be omitted (Simmonds and MacLennan 2008), and this can constitute a large proportion of the water column in shallow systems (e.g. 1-3 m deep). Second, fish may avoid the boat when they are close enough to detect it (Draščík and Kubečka 2005; Godlewska et al. 2009). Because vertical beaming samples water beneath the vessel, boat avoidance behavior could result in fish vacating the sampled volume of water and result in consistently biased observations. Third, the small portion of the water column that is far enough from the boat to be out of the near field and prevent boat avoidance behavior by fish is even further reduced by the poor differentiation of fish from substrate when they are located near bottom (Ona and Mitson 1996; Thorne 1998; Totland et al. 2009). The net result of all these factors is that only a small proportion of the water

column is available for sampling fish with vertically-oriented echosounders, and very little data can be collected from this approach, especially at shallow depths near the boat (where nearfield and boat avoidance are issues). Further, reduced sample volume combined with the non-normal distribution of fish can result in highly variable estimates (Bodine et al. 2011). Therefore, Gizzard Shad, which are typically found near the surface, would not be sampled effectively using vertical beaming, but may be sampled effectively with horizontally-oriented echosounders (Miller 1960; Kubecka et al. 1994; Kubecka and Wittingerova 1998; Knudsen and Sægrov 2002; Frouzova et al. 2005; Boswell et al. 2007; Godlewska et al. 2012). Horizontally-oriented echosounders consist of directing the acoustic beam horizontally or slightly downward from horizontal (Kubecka and Wittingerova 1998; Thorne 1998; Yule 2000; Knudsen and Sægrov 2002; Boswell et al. 2007; Boswell and Wilson 2008; Godlewska et al. 2012). Because the beam is oriented horizontally data can be collected over large distances on the horizontal plane increasing the volume of water sampled (Thorne 1998). Also, because the transducer is typically lowered to approximately 1 m in depth, near surface fishes are also sampled efficiently when beaming horizontally (Kubecka and Wittingerova 1998; Thorne 1998; Knudsen and Sægrov 2002). Therefore, horizontal beaming could be an alternative to current sampling methods in shallow waterbodies while vertical beaming would be ineffective.

Before a horizontal hydroacoustic sampling protocol for Gizzard Shad can be developed, gear accuracy and precision must be addressed. Without accuracy and precision estimates, conclusions from data collected with horizontal beaming may be incorrect. Previous literature has addressed the sampling precision (precision associated with natural variation), but do not address the experimental precision (variability associated with measurement error of the gear) or accuracy of vertical hydroacoustic sampling (Van Den Avyle et al. 1995a; Gangl and Whaley 2004). There is limited literature addressing experimental precision or accuracy of horizontal hydroacoustics and none for Gizzard shad (Yule 2000). Therefore, measures of gear accuracy and precision are

needed to determine if horizontally-oriented echosounders provide quality data to quantify Gizzard Shad populations.

One limitation of horizontally-oriented approaches is that the orientation of the insonified fish can have an effect on the measured target strength (Boswell and Wilson 2008; Rodríguez-Sánchez et al. 2015). Currently, when analyzing acoustic data collected from horizontally-oriented echosounders, insonified fish are assumed to be either randomly oriented (Frouzova et al. 2005) or perpendicular (Lilja et al. 2000; Boswell and Wilson 2008) to the acoustic axis and an average or maximum TS-TL equation is used. There has been one attempt to model the change in TS as fish orientation changes, finding a  $\cos^3$  function to best describe the change in TS (Lilja et al. 2000). By neglecting to test the fit of non- $\cos^x$  functions, the possibility of different functions providing a better fit was ignored. Before developing an orientation-based equation for Gizzard Shad, different function shapes should be compared to ensure the curve shape that best describes the change in TS is selected.

Managers need precise and accurate Gizzard Shad data to better manage piscivore populations. Horizontally-oriented echosounders have potential to be a superior sampling method for collecting data describing the abundance and spatial variation on Gizzard Shad, but more information is needed before it can be implemented as a sampling gear. Accuracy and precision data are needed to determine if horizontally-oriented echosounders provide reliable and consistent data. Data from an orientation-based TS-TL equation could be used to provide more accurate information used in hydroacoustic analyses resulting in increased accuracy of density and biomass estimates. In this study I estimated the experimental precision and accuracy of horizontally-oriented echosounders and developed an orientation-based TS-TL equation for Gizzard Shad that can be used in the implementation of a sampling protocol.

## References

- Allen, M., J. Greene, F. Snow, M. Maceina, and D. DeVries. 1999. Recruitment of largemouth bass in Alabama reservoirs: relations to trophic state and larval shad occurrence. *North American Journal of Fisheries Management* 19(1):67-77.
- Bodine, K. A., D. L. Buckmeier, J. W. Schlechte, and D. E. Shoup. 2011. Effect of electrofishing sampling design on bias of size-related metrics for blue catfish in reservoirs. Pages 607-620 *in* Conservation, ecology, and management of catfish: the second international symposium. American Fisheries Society, Symposium.
- Boswell, K. M., R. Wells, J. H. Cowan Jr, and C. A. Wilson. 2010. Biomass, density, and size distributions of fishes associated with a large-scale artificial reef complex in the Gulf of Mexico. *Bulletin of Marine Science* 86(4):879-889.
- Boswell, K. M., and C. A. Wilson. 2008. Side-aspect target-strength measurements of bay anchovy (*Anchoa mitchilli*) and Gulf menhaden (*Brevoortia patronus*) derived from ex situ experiments. *ICES Journal of Marine Science* 65(6):1012-1020.
- Boswell, K. M., M. P. Wilson, and C. A. Wilson. 2007. Hydroacoustics as a tool for assessing fish biomass and size distribution associated with discrete shallow water estuarine habitats in Louisiana. *Estuaries and Coasts* 30(4):607-617.
- Boxrucker, J. 1986. Evaluation of supplemental stocking of largemouth bass as a management tool in small impoundments. *North American Journal of Fisheries Management* 6(3):391-396.
- Carline, R. F., B. L. Johnson, and T. J. Hall. 1984. Estimation and interpretation of proportional stock density for fish populations in Ohio impoundments. *North American Journal of Fisheries Management* 4(2):139-154.
- Dennerline, D. E., C. A. Jennings, and D. J. Degan. 2012. Relationships between hydroacoustic derived density and gill net catch: Implications for fish assessments. *Fisheries Research* 123:78-89.
- Donovan, N. S., R. A. Stein, and M. M. White. 1997. Enhancing percid stocking success by understanding age-0 piscivore-prey interactions in reservoirs. *Ecological Applications* 7(4):1311-1329.
- Draštík, V., and J. Kubečka. 2005. Fish avoidance of acoustic survey boat in shallow waters. *Fisheries Research* 72(2):219-228.
- Frouzova, J., J. Kubecka, H. Balk, and J. Frouz. 2005. Target strength of some European fish species and its dependence on fish body parameters. *Fisheries Research* 75(1):86-96.
- Gangl, R. S., and R. A. Whaley. 2004. Comparison of fish density estimates from repeated hydroacoustic surveys on two Wyoming waters. *North American Journal of Fisheries Management* 24(4):1279-1287.
- Godlewska, M., B. Długoszewski, and L. Doroszczyk. 2009. Day/night effects of passing boat on fish distribution in the shallow Malta reservoir. *Hydroacoustics* 12:61-68.

- Godlewska, M., J. Frouzova, J. Kubecka, W. Wiśniewolski, and J. Szlakowski. 2012. Comparison of hydroacoustic estimates with fish census in shallow Malta Reservoir— which TS/L regression to use in horizontal beam applications? *Fisheries Research* 123:90-97.
- Johnson, B. M., R. A. Stein, and R. F. Carline. 1988. Use of a quadrat rotenone technique and bioenergetics modeling to evaluate prey availability to stocked piscivores. *Transactions of the American Fisheries Society* 117(2):127-141.
- Knudsen, F. R., and H. Sægrov. 2002. Benefits from horizontal beaming during acoustic survey: application to three Norwegian lakes. *Fisheries Research* 56(2):205-211.
- Kubecka, J., A. Duncan, W. Duncan, D. Sinclair, and A. Butterworth. 1994. Brown trout populations of three Scottish lochs estimated by horizontal sonar and multimesh gill nets. *Fisheries Research* 20(1):29-48.
- Kubecka, J., and M. Wittingerova. 1998. Horizontal beaming as a crucial component of acoustic fish stock assessment in freshwater reservoirs. *Fisheries Research* 35(1):99-106.
- Lilja, J., T. J. Marjomäki, R. Riikonen, and J. Jurvelius. 2000. Side-aspect target strength of Atlantic salmon (*Salmo salar*), brown trout (*Salmo trutta*), whitefish (*Coregonus lavaretus*), and pike (*Esox lucius*). *Aquatic Living Resources* 13(05):355-360.
- Michaletz, P. H. 1998. Effects on sport fish growth of spatial and temporal variation in age-0 gizzard shad availability. *North American Journal of Fisheries Management* 18(3):616-624.
- Miller, R. R. 1960. Systematics and biology of the gizzard shad (*Dorosoma cepedianum*) and related fishes. *Fisheries* 60:371-392.
- Miranda, L. E. 1983. Average ichthyomass in Texas large impoundments. *Proceedings of the Texas Chapter of the American Fisheries Society* 6:58-67.
- Ona, E., and R. Mitson. 1996. Acoustic sampling and signal processing near the seabed: the deadzone revisited. *ICES Journal of Marine Science* 53(4):677-690.
- Ostrand, K. G., H. L. Schramm Jr, J. E. Kraai, and B. Braeutigam. 2001. Effects of intensive stocking of hybrid striped bass on the population structure of gizzard shad in a west Texas impoundment, a case study. Pages 324-333 *in* Proceedings of the Annual Conference Southeastern Association of Fish and Wildlife Agencies.
- Post, J. R., M. R. S. Johannes, and D. J. McQueen. 1997. Evidence of density-dependent cohort splitting in age-0 yellow perch, (*Perca flavescens*): potential behavioural mechanisms and population-level consequences. *Canadian Journal of Fisheries and Aquatic Sciences* 54(4):867-875.
- Rodríguez-Sánchez, V., L. Encina-Encina, A. Rodríguez-Ruiz, and R. Sánchez-Carmona. 2015. Horizontal target strength of *Luciobarbus* sp. in ex situ experiments: Testing differences by aspect angle, pulse length and beam position. *Fisheries Research* 164:214-222.

- Roseman, E. F., E. L. Mills, J. L. Forney, and L. G. Rudstam. 1996. Evaluation of competition between age-0 yellow perch (*Perca flavescens*) and gizzard shad (*Dorosoma cepedianum*) in Oneida Lake, New York. *Canadian Journal of Fisheries and Aquatic Sciences* 53(4):865-874.
- Sammons, S. M., P. W. Bettoli, and F. C. Fiss. 1998. Effect of threadfin shad density on production of threadfin shad and gizzard shad larvae in a Tennessee reservoir. *Environmental Biology of Fishes* 53(1):65-73.
- Schramm, H. L., J. E. Kraai, and C. R. Munger. 1999. Intensive stocking of striped bass to restructure a gizzard shad population in a eutrophic Texas reservoir. Pages 180-192 *in* Proceedings of the Annual Conference Southeastern Association of Fish and Wildlife Agencies.
- Simmonds, J., and D. N. MacLennan. 2008. *Fisheries acoustics: theory and practice*. John Wiley & Sons.
- Stahl, T. P., and coauthors. 1996. Factors affecting survival of age-0 saugeye *Stizostedion vitreum* × *S. canadense* stocked in Ohio reservoirs. *North American Journal of Fisheries Management* 16(2):378-387.
- Stanley, D. R., and C. A. Wilson. 2000. Variation in the density and species composition of fishes associated with three petroleum platforms using dual beam hydroacoustics. *Fisheries Research* 47(2):161-172.
- Taylor, J. C., and S. L. Maxwell. 2007. *Hydroacoustics: lakes and reservoirs*. DH Johnson, BM Shrier, J. S. O'Neal, JA Knutzen, X. Augerot, TA O'Neill, and TN Pearsons. *Salmonid field protocols handbook: techniques for assessing status and trends in salmon and trout populations*. American Fisheries Society, Bethesda, Maryland:153-172.
- Taylor, J. C., J. S. Thompson, P. S. Rand, and M. Fuentes. 2005. Sampling and statistical considerations for hydroacoustic surveys used in estimating abundance of forage fishes in reservoirs. *North American Journal of Fisheries Management* 25(1):73-85.
- Terre, D. R., S. J. Magnelia, and M. J. Ryan. 1993. Year class contribution of genetically-marked Florida x northern largemouth bass stocked in three Texas reservoirs. Pages 622-632 *in* Proceedings of the Annual Conference of Southeastern Association of Fish and Wildlife Agencies.
- Thorne, R. E. 1998. Review: experiences with shallow water acoustics. *Fisheries Research* 35(1):137-141.
- Totland, A., G. O. Johansen, O. R. Godø, E. Ona, and T. Torkelsen. 2009. Quantifying and reducing the surface blind zone and the seabed dead zone using new technology. *ICES Journal of Marine Science* 66(6):1370-1376.
- Van Den Avyle, M. J., J. Boxrucker, P. Michaletz, B. Vondracek, and G. R. Ploskey. 1995a. Comparison of catch rate, length distribution, and precision of six gears used to sample reservoir shad populations. *North American Journal of Fisheries Management* 15(4):940-955.



- Van Den Avyle, M. J., G. R. Ploskey, and P. W. Bettoli. 1995b. Evaluation of gill-net sampling for estimating abundance and length frequency of reservoir shad populations. *North American Journal of Fisheries Management* 15(4):898-917.
- Vondracek, B., and D. J. Degan. 1995. Among-and within-transect variability in estimates of shad abundance made with hydroacoustics. *North American Journal of Fisheries Management* 15(4):933-939.
- Yule, D. L. 2000. Comparison of horizontal acoustic and purse-seine estimates of salmonid densities and sizes in eleven Wyoming waters. *North American Journal of Fisheries Management* 20(3):759-775.

## CHAPTER II

### ACCURACY AND PRECISION OF HYDROACOUSTIC ESTIMATES OF GIZZARD SHAD ABUNDANCE USING HORIZONTAL BEAMING

#### **Abstract**

Gizzard Shad (*Dorosoma cepedianum*) are an important prey species in lakes and reservoirs throughout much of the United States. Gizzard Shad abundance and size-structure data are often used when making management decisions for piscivorous fish species (i.e. stocking rates determined by juvenile Gizzard Shad abundance). Currently, gill nets are the most common gear used to collect Gizzard Shad population characteristics, but this gear can be time and labor intensive, lacks precision, and may lack accuracy. Horizontally-oriented echosounders may be a better alternative, but accuracy and precision must be measured to determine if this sampling technique produces reliable data. I released Gizzard Shad into a net pen (15-m long x 15-m wide x 4.5-m deep with 6.35-mm square mesh) to produce several different densities of fish. Data were collected using a Simrad EK60 120 kHz split-beam echosounder operating at 10 Hz using five replicate passes per fish-density treatment. Target counting and echo integration were used to estimate fish density (fish/m<sup>3</sup>) from each sampling pass. Mean density estimates were then compared to known densities using linear mixed effects model and a CV was calculated for each trial from the five sampling passes. I found that the slope was not significantly different from one ( $F_{1,13}=62.99$ ,  $P=0.42$ ) but the intercept was significantly greater than zero ( $t=2.89$ ,  $d.f.=88$ ,  $P<0.01$ ) indicating horizontally-oriented echosounders can accurately detect changes in Gizzard

Shad density, but may overestimate actual density. Mean CV (6%) from echosounder samples was lower than CV reported for other gears when sampling Gizzard Shad. Horizontally-oriented echosounders estimated relative Gizzard Shad density with high accuracy and precision indicating data collected with this method would be reliable when making management decisions.

## **Introduction**

Gizzard Shad (*Dorosoma cepedianum*) are an important prey species in lakes and reservoirs throughout southern and mid-latitudes of the United States, and routinely have the highest density and largest biomass of all prey types within these systems (Miranda 1983; Carline et al. 1984; Johnson et al. 1988). When abundant, age-0 Gizzard Shad density can increase growth rates and over-winter survival of piscivorous fish (Stahl et al. 1996; Michaletz 1998; Allen et al. 1999). However, when age-0 Gizzard Shad are not abundant, piscivore communities may have limited population size and poor growth (Evans et al. 2014). In many aquatic systems, piscivore populations are supplemented or maintained through stocking efforts to improve recreational fishing (Boxrucker 1986; Terre et al. 1993), providing an opportunity to use information about juvenile Gizzard Shad abundance to determine appropriate stocking numbers for sportfishes (i.e. saugeye and hybrid striped bass; Donovan et al. 1997). However, this opportunity relies on accurate estimates of prey abundance (Donovan et al. 1997). If Gizzard Shad abundance is over-estimated, erroneously high stocking rates for predators could result, depleting prey populations and lowering survival of stocked fish or naturally-reproducing piscivores due to density-dependent growth and resultant mortality (Post et al. 1997). Conversely, if Gizzard Shad abundance is under estimated, erroneously-low stocking rates for predators could lead to an over-abundant Gizzard Shad population with large size structure, which can compete with juvenile sportfish that feed on zooplankton (Roseman et al. 1996). Further, Gizzard Shad populations with large size-structure typically exhibit low recruitment, thus decreasing available prey for juvenile sportfish (Sammons et al. 1998; Schramm et al. 1999; Ostrand et al. 2001). Therefore, accurately

estimating age-0 Gizzard Shad abundance is critical to effective and sustainable piscivore management.

Currently, gill nets are the most common gear used to collect Gizzard Shad population characteristics, but hydroacoustics have the potential to produce better data with less effort at the same level of precision (Van Den Avyle et al. 1995b). Gillnet-derived estimates of Gizzard Shad abundance can be time and labor intensive, lack precision, and may lack accuracy (Van Den Avyle et al. 1995a; Van Den Avyle et al. 1995b). Hydroacoustic sampling has potential to provide precise estimates of pelagic prey fish abundance with less time and effort (Van Den Avyle et al. 1995a; Taylor et al. 2005; Taylor and Maxwell 2007). For example, surface-set gill nets take seven times more person-hours than hydroacoustics to collect sufficient samples to detect a 25% difference in mean catch rates of Gizzard Shad (includes data processing time for hydroacoustic sampling; Van Den Avyle et al. 1995a). It takes 30-40 net nights to detect a 25% difference in Gizzard Shad abundance using gill nets (Wilde 1995), but only 14-25 5-minute hydroacoustic transects (14-25 total person-hours for sampling and processing; Van Den Avyle et al. 1995a). Therefore, sampling Gizzard Shad populations with hydroacoustics would result in reduced time and effort to acquire Gizzard shad population characteristics (Van Den Avyle et al. 1995a; Dennerline et al. 2012).

Traditional hydroacoustic sampling procedures utilize a transducer oriented vertically, beaming straight down or at a slight angle (Vondracek and Degan 1995; Stanley and Wilson 2000; Boswell et al. 2010), which can be ineffective in shallow water due to reduced sample volume (nearfield exclusion and bottom differentiation) and fish behavior (boat avoidance or avoidance of hypoxic conditions in the hypolimnion; Simmonds and MacLennan 2008; Godlewska et al. 2009; Roberts et al. 2009). As a result, only a small proportion of the water column is available for sampling fish with vertical hydroacoustics in shallow systems. Further, reduced sample volume combined with a non-homogenous distribution of fish (i.e., patchy distributions) can

result in highly variable estimates (Bodine et al. 2011). Gizzard Shad are typically found near the surface and would not be sampled effectively using vertical beaming, but may be sampled effectively with horizontally-oriented echosounders (Miller 1960).

There is limited literature addressing precision of horizontal beaming (Yule 2000), but literature measuring precision of vertical beaming may provide insight. In comparative studies, vertical beaming had higher precision than seining, trawling, rotenone, surface and bottom-set gill nets, electrofishing, (Van Den Avyle et al. 1995a; Achleitner et al. 2012) drop traps (Nellbring 1985), and experimental gill nets (Hansson 1984). Horizontal beaming may have similar precision to vertical beaming, but because horizontal beaming samples near-surface fish, surface disturbances may have an increased effect on precision (Gangl and Whaley 2004; Totland et al. 2009). Further, spatial heterogeneity in fish abundance may differ for near-surface fish and fish inhabiting deeper locations, resulting in variation in precision estimated between horizontal and vertical approaches. As such, further research is needed to quantify precision for data collected with horizontal echosounders. Like precision, accuracy of horizontal echosounders have also not been evaluated. Comparisons between Horizontally-oriented echosounder estimates and gillnets (Kubecka et al. 1994; Boswell et al. 2007; Tátrai et al. 2008), purse seining (Yule 2000), and push trawls (Boswell et al. 2007) identified differences in relative abundance, but these studies could not confirm which, if any, gear was more accurate. The accuracy of fisheries sampling gears has been difficult to estimate because we rarely know the true population characteristics for fish species. Knowledge of the experimental accuracy and precision of horizontally-oriented echosounders would determine if Gizzard Shad population data collected with this gear provides better data for management decision making.

Gizzard Shad population characteristics are often considered when making sportfish management decisions, but current sampling techniques are inefficient and may be unreliable. Horizontal beaming has real promise as a method to collect precise and accurate data with less effort than

current sampling methods, but research is needed to confirm this (Van Den Avyle et al. 1995a). I propose to test the precision and accuracy of hydroacoustic estimates by sampling known populations of Gizzard Shad.

## **Methods**

Gizzard Shad of various sizes (60-300 mm TL; variable numbers) were collected from Lake Carl Blackwell, Stillwater, OK, daily, using boat electrofishing, counted, and released into a nylon net pen (15-m long x 15-m wide x 4.5-m deep with 6.35-mm square mesh) located within the lake. Fish were given  $\geq 30$  minutes to acclimate based on observations that fish behavior inside the pen was similar to unconstrained fish within the lake after this period of time (observations made with an ARIS<sup>®</sup> Explorer 1800 imaging SONAR operating at 1.8 MHz). The pen remained in the water for no more than four consecutive days and fish were added to increase total density between trials. The number of fish added was not predetermined, but I ensured that a wide range of fish abundances were sampled, typically with some low- and some high-density trials from each net set (37-526 individuals; Table 1). For analyses, known abundance was divided by the volume of the net (1,012.5 m<sup>3</sup>) to acquire a density. A total of 22 trials (8 total net sets) with different fish densities were conducted.

To estimate handling mortality, dead fish (5-25 individuals per net set) that were observed were collected from the net daily and counted. At the end of each 3- or 4-day net set, the net was retrieved and remaining dead fish (i.e., fish that did not float) were also counted. All fish removed were enumerated and measured (mm TL). Density (0.04-0.52 fish/m<sup>3</sup>) estimates for each trial were adjusted assuming a constant initial mortality rate for all fish introduced through the week (i.e., total mortalities were attributed proportionally based on number of fish added between recordings).

Hydroacoustic data were collected simultaneously using a Simrad® EK60 120 kHz echosounder and an ARIS® Explorer 1800 imaging SONAR equipped with an 8° condensing lens operating at 1.8 MHz. Echosounder data was collected at 10 Hz and a threshold of -70 dB. Transducer properties can be found in Table 2. Imaging SONAR data were used to ensure fish had natural behaviors and echosounder transducer was at the proper angle, but were not used in analyses. Both transducers were mounted on a bracket that was lowered to a depth of 1m within one side of the net pen facing across the pen (Figure 1). The split-beam transducer was angled 3.5° downward from horizontal to reduce surface noise and maximize sample volume. Recordings were collected by pulling the boat along one side of the net five times consecutively with a mean speed of 0.1 m/s. Trials occurred at night because shad species become less aggregated and further from the net walls, making echo-counting possible (Schael et al. 1995). Daytime observations using the imaging SONAR indicated shad were attracted to plankton growing on the net, making separation of fish targets from pen edges difficult. Trials were conducted in late summer when water temperatures ranged from 23°-30° C with a mean of 26.8° C (SD=1.96) during trials.

Hydroacoustic analyses were completed using Echoview® 8.1. A target-detection algorithm (detection parameters are in Table 2) was used to detect fish targets that were then manually converted to fish tracks (consisting of at least five targets). When aggregations of fish occurred, an echo-integration technique was used to estimate the number of fish within the aggregation (volume backscattering strength of each aggregation was scaled by mean TS of individual fish tracks from the same sampling pass to estimate the number of fish in each aggregation), which were then added to the total abundance (Boswell et al. 2007; Busch and Mehner 2009). The net pen returned a strong, consistent echo approximately 15m from the transducer and at closer distances when approaching perpendicular sides. Any potential targets that were not clearly differentiable from the net pen echo, were not included. Estimated densities (from hydroacoustic

analysis) were compared to known densities (based on number of fish in the pen) and a coefficient of variation was calculated from the five replicates of each trial.

A linear mixed effects model was used to compare estimated fish densities to known densities with net set and trial as random effects in program R (lme; Pinheiro et al. 2017). An ANOVA was used to test for differences in density between the five replicate recordings to detect any influence of previous recordings on subsequent recordings (e.g., boat avoidance) with trial as a random effect (ANOVA; [R Core Team 2016](#)). All analyses were completed using Program R (R Core Team 2016) and significance was evaluated with  $\alpha \leq 0.05$ . Coefficients of variation of the mean (CV; SE/Mean from each set of five replicate measurements at each fish density) were tested to determine if CV was consistent across known fish densities with simple linear regression (lm; [R Core Team 2016](#)).

## Results

Estimated density increased as actual density increased with a slope of 0.89 and intercept of 0.13 (Figure 2). The slope was not significantly different from one ( $F_{1,13}=62.99$ ,  $P=0.42$ ), but the intercept was significantly greater than zero ( $t=2.89$ , d.f. = 88,  $P<0.01$ ). There were no significant differences between the five measurements in each trial ( $F_{4,105} = 0.38$ ,  $P=0.82$ ). The mean CV was 6.8 % and ranged from 2-14% across all densities. There was no apparent trend for CV as density changed ( $F_{1,20} = 0.02$ ,  $P=0.88$ , Figure 3).

## Discussion

My results suggest hydroacoustic sampling can accurately detect differences in Gizzard Shad density (i.e., slope of known abundance and estimated abundance was not significantly different from one), but may overestimate at all densities (intercept was significantly greater than zero). Over-estimation is expected because Gizzard Shad often aggregate near the surface (Miller 1960;



Bodola 1966; Becker 1983), suggesting there was a greater density (fish/m<sup>3</sup>) of fish in the portion of the net pen that was sampled by the acoustic beam. This phenomenon should be minimized in shallow water and when sampling distance isn't artificially restricted because a larger portion of the water column will be sampled, including deeper areas with lower abundances of fish. Over-estimation could also result from boat avoidance (Draštík and Kubečka 2005), increasing the number of fish in the far-field of the acoustic beam. However, boat avoidance seems unlikely because fish tracks were detected both near and far from the transducer and no difference in density was detected among the five repeated measurements for each trial (i.e., if boat avoidance occurred, an increase in abundance at the opposite end would have been observed).

Gear accuracy in lakes and reservoirs has been difficult to estimate because we often do not know true abundance; therefore, limited literature is available investigating accuracy with known populations (Fujimori et al. 1996; Santucci Jr et al. 1999). However, research without known fish densities has determined that accuracy of hydroacoustic estimates can be affected by uncertainty in standard sphere calibration, TS estimates, species delineation, and fish behavior (Demer 1994; Simmonds and MacLennan 2008), spatial sampling error (Simmonds and MacLennan 2008), and analysis techniques and parameters (Rose et al. 2000; O'Driscoll 2003; Simmonds and MacLennan 2008) among other factors. Without knowing the true density of fish in the sample area, a true accuracy cannot be determined. Controlling the number of individuals can be difficult to accomplish on a large scale, but can be addressed on a smaller scale, as I did with a large net pen.

I found horizontally-oriented echosounder density also has a high degree of precision compared to other gears used to sample Gizzard Shad. In a multiple-gear evaluation, the precision of various gears when sampling shad species (*Dorosoma* spp.) ranged from 11-61% (Van Den Avyle et al. 1995a). These values are all higher than my mean CV (6%) and the lowest CV estimate of many of these gears is higher than my highest measured CV from any individual trial

(14%). No prior studies have compared precision of Gizzard Shad abundance estimates from horizontally-oriented echosounders with other gears, but horizontally-oriented echosounders abundance estimates have less variation than purse seining for salmonids (Yule 2000) and combining data from split beam echosounders with DIDSON data increases precision of anadromous fish abundance estimates (Warren 2006; Hughes 2012). My results are, therefore, consistent with other literature suggesting that hydroacoustics may produce more precise data than other gears that measure fish abundance.

Some aspects of study design affect precision, so it is possible that precision will differ between different sampling applications with the same gear (Clarke and Green 1988; Kritzer et al. 2001; Snijders 2005; Kowalewski et al. 2015). For hydroacoustic sampling, samples from small spatial scales (as done in my study) leads to greater precision, but short transect lengths and limited replication (also characteristic of my study) can lead to reduced precision estimates (Kritzer et al. 2001; Kowalewski et al. 2015). Because my results suggest that horizontal beaming has a high precision despite low replication and small transect length, there is potential to further improve precision with increased sample size (Kritzer et al. 2001) and duration (Vondracek and Degan 1995; Kowalewski et al. 2015). However, reduced spatial heterogeneity in my study, caused by confining fish in a net pen, may have reduced measured variance and consequently artificially increased my precision estimate (Baroudy and Elliott 1993). Additional research should be conducted to evaluate the precision of horizontal echosounders when sampling Gizzard Shad at larger spatial scales (i.e., whole-lake sampling), but my study provides an estimate of precision at smaller scales (i.e. within a transect or group of transects in a similar area), and suggests this approach may generate estimates with increased precision relative to other sampling methods.

My results suggest horizontal echosounders should be considered for sampling Gizzard Shad in shallow reservoirs because they produce accurate relative abundance data, have a high degree of precision at the scale tested, and efficiently sample near-surface fish that vertically-oriented

echosounders would not. Hydroacoustic sampling (including data processing time) typically requires less person-hours than other common Gizzard Shad sampling methods at a given level of precision (Van Den Avyle et al. 1995a). The use of hydroacoustic sampling techniques to collect Gizzard Shad population data could therefore increase the accuracy and precision of biomass estimates in shallow reservoirs which would improve overall fisheries management.

## References

- Achleitner, D., H. Gassner, and M. Luger. 2012. Comparison of three standardised fish sampling methods in 14 alpine lakes in Austria. *Fisheries Management and Ecology* 19(4):352-361.
- Allen, M., J. Greene, F. Snow, M. Maceina, and D. DeVries. 1999. Recruitment of largemouth bass in Alabama reservoirs: relations to trophic state and larval shad occurrence. *North American Journal of Fisheries Management* 19(1):67-77.
- Baroudy, E., and J. Elliott. 1993. The effect of large-scale spatial variation of pelagic fish on hydroacoustic estimates of their population density in Windermere (northwest England). *Ecology of Freshwater Fish* 2(4):160-166.
- Becker, G. C. 1983. fishes of Wisconsin. University of Wisconsin Press, Madison.
- Bodine, K. A., D. L. Buckmeier, J. W. Schlechte, and D. E. Shoup. 2011. Effect of electrofishing sampling design on bias of size-related metrics for blue catfish in reservoirs. Pages 607-620 *in* Conservation, ecology, and management of catfish: the second international symposium. American Fisheries Society, Symposium.
- Bodola, A. 1966. Life history of the gizzard shad, *Dorosoma cepedianum* (Le Sueur), in western Lake Erie. *Fishery Bulletin* 65(2):391-425.
- Boswell, K. M., R. Wells, J. H. Cowan Jr, and C. A. Wilson. 2010. Biomass, density, and size distributions of fishes associated with a large-scale artificial reef complex in the Gulf of Mexico. *Bulletin of Marine Science* 86(4):879-889.
- Boswell, K. M., M. P. Wilson, and C. A. Wilson. 2007. Hydroacoustics as a tool for assessing fish biomass and size distribution associated with discrete shallow water estuarine habitats in Louisiana. *Estuaries and Coasts* 30(4):607-617.
- Boxrucker, J. 1986. Evaluation of supplemental stocking of largemouth bass as a management tool in small impoundments. *North American Journal of Fisheries Management* 6(3):391-396.
- Busch, S., and T. Mehner. 2009. Hydroacoustic estimates of fish population depths and densities at increasingly longer time scales. *International Review of Hydrobiology* 94(1):91-102.

- Carline, R. F., B. L. Johnson, and T. J. Hall. 1984. Estimation and interpretation of proportional stock density for fish populations in Ohio impoundments. *North American Journal of Fisheries Management* 4(2):139-154.
- Clarke, K., and R. Green. 1988. Statistical design and analysis for a 'biological effects' study. *Marine Ecology Progress Series*:213-226.
- Demer, D. A. 1994. Accuracy and precision of echo integration surveys of Antarctic krill. University of California, San Diego.
- Dennerline, D. E., C. A. Jennings, and D. J. Degan. 2012. Relationships between hydroacoustic derived density and gill net catch: Implications for fish assessments. *Fisheries Research* 123:78-89.
- Donovan, N. S., R. A. Stein, and M. M. White. 1997. Enhancing percid stocking success by understanding age-0 piscivore-prey interactions in reservoirs. *Ecological Applications* 7(4):1311-1329.
- Draštík, V., and J. Kubečka. 2005. Fish avoidance of acoustic survey boat in shallow waters. *Fisheries Research* 72(2):219-228.
- Evans, N., D. Shoup, and D. Glover. 2014. A simplified approach for estimating age-0 gizzard shad prey supply and predator demand. *Fisheries Management and Ecology* 21(2):140-154.
- Fujimori, Y., T. Tokai, S. Hiyama, and K. Matuda. 1996. Selectivity and gear efficiency of trammel nets for kuruma prawn (*Penaeus japonicus*). *Fisheries Research* 26(1):113-124.
- Gangl, R. S., and R. A. Whaley. 2004. Comparison of fish density estimates from repeated hydroacoustic surveys on two Wyoming waters. *North American Journal of Fisheries Management* 24(4):1279-1287.
- Godlewska, M., B. Długoszewski, and L. Doroszczyk. 2009. Day/night effects of passing boat on fish distribution in the shallow Malta reservoir. *Hydroacoustics* 12:61-68.
- Hansson, S. 1984. Competition as a factor regulating the geographical distribution of fish species in a Baltic archipelago: a neutral model analysis. *Journal of biogeography*:367-381.
- Hughes, J. B. 2012. Combining Count Data from Split-beam and Multiple DIDSON Sonar Techniques to Estimate Spawning Run Abundance of Anadromous Fishes in the Roanoke River, NC. North Carolina State University, NCSU Librariy.
- Johnson, B. M., R. A. Stein, and R. F. Carline. 1988. Use of a quadrat rotenone technique and bioenergetics modeling to evaluate prey availability to stocked piscivores. *Transactions of the American Fisheries Society* 117(2):127-141.
- Kowalewski, L. K., C. J. Chizinski, L. A. Powell, K. L. Pope, and M. A. Pegg. 2015. Accuracy or precision: Implications of sample design and methodology on abundance estimation. *Ecological Modelling* 316:185-190.

- Kritzer, J., C. Davies, and B. Mapstone. 2001. Characterizing fish populations: effects of sample size and population structure on the precision of demographic parameter estimates. *Canadian Journal of Fisheries and Aquatic Sciences* 58(8):1557-1568.
- Kubecka, J., A. Duncan, W. Duncan, D. Sinclair, and A. Butterworth. 1994. Brown trout populations of three Scottish lochs estimated by horizontal sonar and multimesh gill nets. *Fisheries Research* 20(1):29-48.
- Michaletz, P. H. 1998. Effects on sport fish growth of spatial and temporal variation in age-0 gizzard shad availability. *North American Journal of Fisheries Management* 18(3):616-624.
- Miller, R. R. 1960. Systematics and biology of the gizzard shad (*Dorosoma cepedianum*) and related fishes. *Fisheries* 60:371-392.
- Miranda, L. E. 1983. Average ichthyomass in Texas large impoundments. *Proceedings of the Texas Chapter of the American Fisheries Society* 6:58-67.
- Nellbring, S. 1985. Abundance, biomass, and seasonal variation of fish on shallow soft bottoms in the Askö area, northern Baltic proper. *Sarsia* 70(2-3):217-225.
- O'Driscoll, R. L. 2003. Determining species composition in mixed-species marks: an example from the New Zealand hoki (*Macrurus novaezelandiae*) fishery. *ICES Journal of Marine Science* 60(3):609-616.
- Ostrand, K. G., H. L. Schramm Jr, J. E. Kraai, and B. Braeutigam. 2001. Effects of intensive stocking of hybrid striped bass on the population structure of gizzard shad in a west Texas impoundment, a case study. Pages 324-333 *in* Proceedings of the Annual Conference Southeastern Association of Fish and Wildlife Agencies.
- Pinheiro, J., D. Bates, S. DebRoy, and R Core Team. 2017. nlme: Linear and Nonlinear Mixed Effects Models.
- Post, J. R., M. R. S. Johannes, and D. J. McQueen. 1997. Evidence of density-dependent cohort splitting in age-0 yellow perch, (*Perca flavescens*): potential behavioural mechanisms and population-level consequences. *Canadian Journal of Fisheries and Aquatic Sciences* 54(4):867-875.
- R Core Team. 2016. A Language and Environment for Statistical Computing. R Foundation for Statistical Computing.
- Roberts, J. J., and coauthors. 2009. Effects of hypolimnetic hypoxia on foraging and distributions of Lake Erie yellow perch. *Journal of Experimental Marine Biology and Ecology* 381:S132-S142.
- Rose, G., S. Gauthier, and G. Lawson. 2000. Acoustic surveys in the full monte: simulating uncertainty. *Aquatic Living Resources* 13(5):367-372.

- Roseman, E. F., E. L. Mills, J. L. Forney, and L. G. Rudstam. 1996. Evaluation of competition between age-0 yellow perch (*Perca flavescens*) and gizzard shad (*Dorosoma cepedianum*) in Oneida Lake, New York. *Canadian Journal of Fisheries and Aquatic Sciences* 53(4):865-874.
- Sammons, S. M., P. W. Bettoli, and F. C. Fiss. 1998. Effect of threadfin shad density on production of threadfin shad and gizzard shad larvae in a Tennessee reservoir. *Environmental Biology of Fishes* 53(1):65-73.
- Santucci Jr, V. J., D. H. Wahl, and D. F. Clapp. 1999. Efficiency and selectivity of sampling methods used to collect channel catfish in impoundments. Pages 317-328 *in* *Catfish 2000: proceedings of the international ictalurid symposium*. American Fisheries Society, Symposium.
- Schael, D. M., J. A. Rice, and D. J. Degan. 1995. Spatial and temporal distribution of threadfin shad in a southeastern reservoir. *Transactions of the American Fisheries Society* 124(6):804-812.
- Schramm, H. L., J. E. Kraai, and C. R. Munger. 1999. Intensive stocking of striped bass to restructure a gizzard shad population in a eutrophic Texas reservoir. Pages 180-192 *in* *Proceedings of the Annual Conference Southeastern Association of Fish and Wildlife Agencies*.
- Simmonds, J., and D. N. MacLennan. 2008. *Fisheries acoustics: theory and practice*. John Wiley & Sons.
- Snijders, T. A. 2005. Power and sample size in multilevel linear models. *Encyclopedia of statistics in behavioral science*.
- Stahl, T. P., and coauthors. 1996. Factors affecting survival of age-0 saugeye *Stizostedion vitreum* × *S. canadense* stocked in Ohio reservoirs. *North American Journal of Fisheries Management* 16(2):378-387.
- Stanley, D. R., and C. A. Wilson. 2000. Variation in the density and species composition of fishes associated with three petroleum platforms using dual beam hydroacoustics. *Fisheries Research* 47(2):161-172.
- Tátrai, I., A. Specziár, A. György, and P. Bíró. 2008. Comparison of fish size distribution and fish abundance estimates obtained with hydroacoustics and gill netting in the open water of a large shallow lake. Pages 231-240 *in* *Annales de Limnologie-International Journal of Limnology*. Cambridge Univ Press.
- Taylor, J. C., and S. L. Maxwell. 2007. *Hydroacoustics: lakes and reservoirs*. DH Johnson, BM Shrier, J. S. O'Neal, JA Knutzen, X. Augerot, TA O'Neill, and TN Pearsons. *Salmonid field protocols handbook: techniques for assessing status and trends in salmon and trout populations*. American Fisheries Society, Bethesda, Maryland:153-172.
- Taylor, J. C., J. S. Thompson, P. S. Rand, and M. Fuentes. 2005. Sampling and statistical considerations for hydroacoustic surveys used in estimating abundance of forage fishes in reservoirs. *North American Journal of Fisheries Management* 25(1):73-85.

- Terre, D. R., S. J. Magnelia, and M. J. Ryan. 1993. Year class contribution of genetically-marked Florida x northern largemouth bass stocked in three Texas reservoirs. Pages 622-632 *in* Proceedings of the Annual Conference of Southeastern Association of Fish and Wildlife Agencies.
- Totland, A., G. O. Johansen, O. R. Godø, E. Ona, and T. Torkelsen. 2009. Quantifying and reducing the surface blind zone and the seabed dead zone using new technology. *ICES Journal of Marine Science* 66(6):1370-1376.
- Van Den Avyle, M. J., J. Boxrucker, P. Michaletz, B. Vondracek, and G. R. Ploskey. 1995a. Comparison of catch rate, length distribution, and precision of six gears used to sample reservoir shad populations. *North American Journal of Fisheries Management* 15(4):940-955.
- Van Den Avyle, M. J., G. R. Ploskey, and P. W. Bettoli. 1995b. Evaluation of gill-net sampling for estimating abundance and length frequency of reservoir shad populations. *North American Journal of Fisheries Management* 15(4):898-917.
- Vondracek, B., and D. J. Degan. 1995. Among-and within-transect variability in estimates of shad abundance made with hydroacoustics. *North American Journal of Fisheries Management* 15(4):933-939.
- Warren, M. 2006. Estimating Run Size of Anadromous Fishes in the Roanoke River, North Carolina, using Hydroacoustics. North Carolina State University, NCSU Library.
- Wilde, G. R. 1995. Gill net sample size requirements for temperate basses, shads, and catfishes. Pages 588-595 *in* Proceedings of the Annual Conference Southeastern Association of Fish and Wildlife Agencies.
- Yule, D. L. 2000. Comparison of Horizontal Acoustic and Purse-Seine Estimates of Salmonid Densities and Sizes in Eleven Wyoming Waters. *North American Journal of Fisheries Management* 20(3):759-775.

## Tables

Table 1. Trial number, net set, abundance and density for each net pen (15-m long x 15-m wide x 4.5-m deep) trial to evaluate Gizzard Shad (*Dorosoma cepedianum*) density estimation with a horizontally-oriented echosounder.

<b>Trial</b>	<b>Net Set</b>	<b>Abundance</b>	<b>Density (fish/m<sup>3</sup>)</b>
1	1	308	0.30
2	1	352	0.35
3	2	43	0.04
4	2	104	0.10
5	2	154	0.15
6	2	204	0.20
7	2	335	0.33
8	2	385	0.38
9	3	72	0.07
10	3	387	0.38
11	3	461	0.46
12	3	468	0.46
13	3	526	0.52
14	4	37	0.04
15	4	333	0.33
16	5	299	0.30
17	5	384	0.38
18	6	66	0.07
19	6	174	0.17
20	6	229	0.23
21	7	139	0.14
22	8	90	0.09



Table 2. Echosounder, transducer and analysis parameters used during data collection and analyses for net pen trials with Gizzard Shad.

<b>System parameters</b>	<b>Value</b>
SIMRAD EK60 split-beam echosounder	
Operating Frequency	120 kHz
Pulse Duration	0.256 ms
Pulse rate	10 Hz
<b>Transducer parameters</b>	
Two-way beam angle	-20.7
Collection Threshold	-70 dB
Beam width	7°
Nearfield range	2 m
<b>Analysis Threshold</b>	
Target strength	-65 dB
<b>Single target detector</b>	
Pulse length determination level	6 dB
Minimum normalized pulse length	0.5
maximum normalized pulse length	1.8
Maximum beam compensation	6 dB
Maximum standard deviation of	
Minor axis angle	1.0°
major-axis angles	1.0°

## Figures

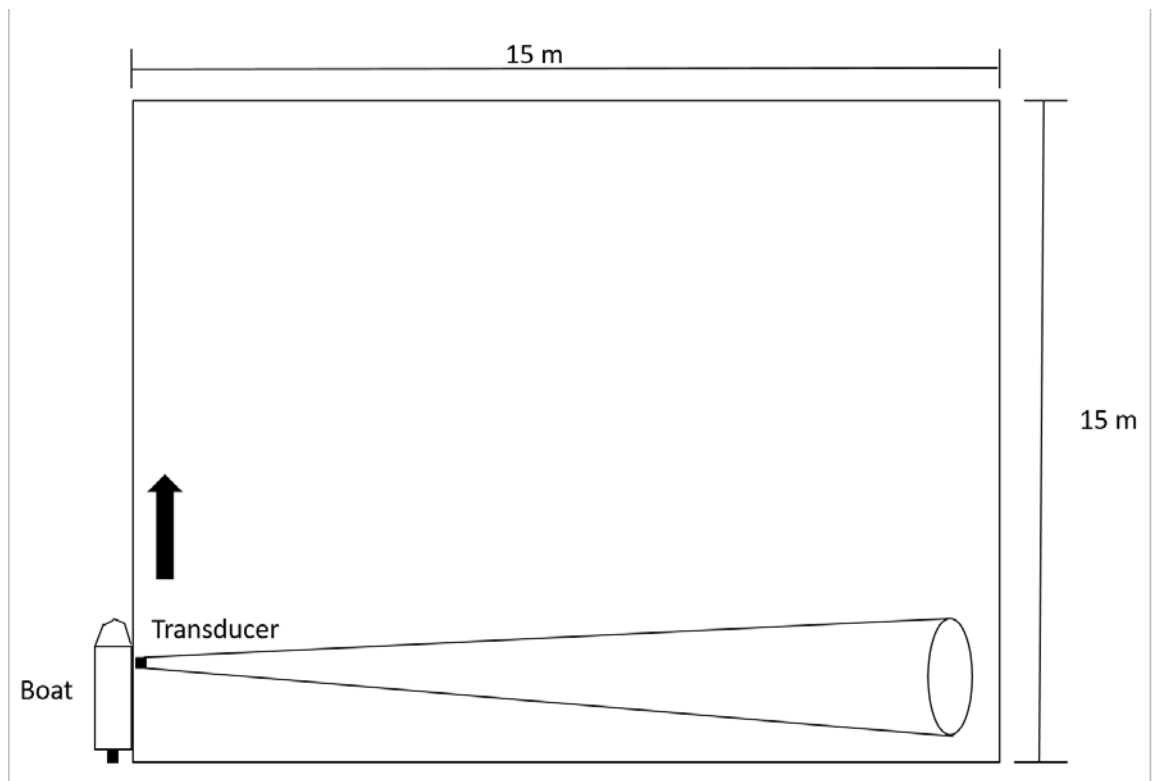

Figure 1. Plan-view diagram depicting the net pen used to test the accuracy and precision of Gizzard Shad abundance using hydroacoustic sampling.

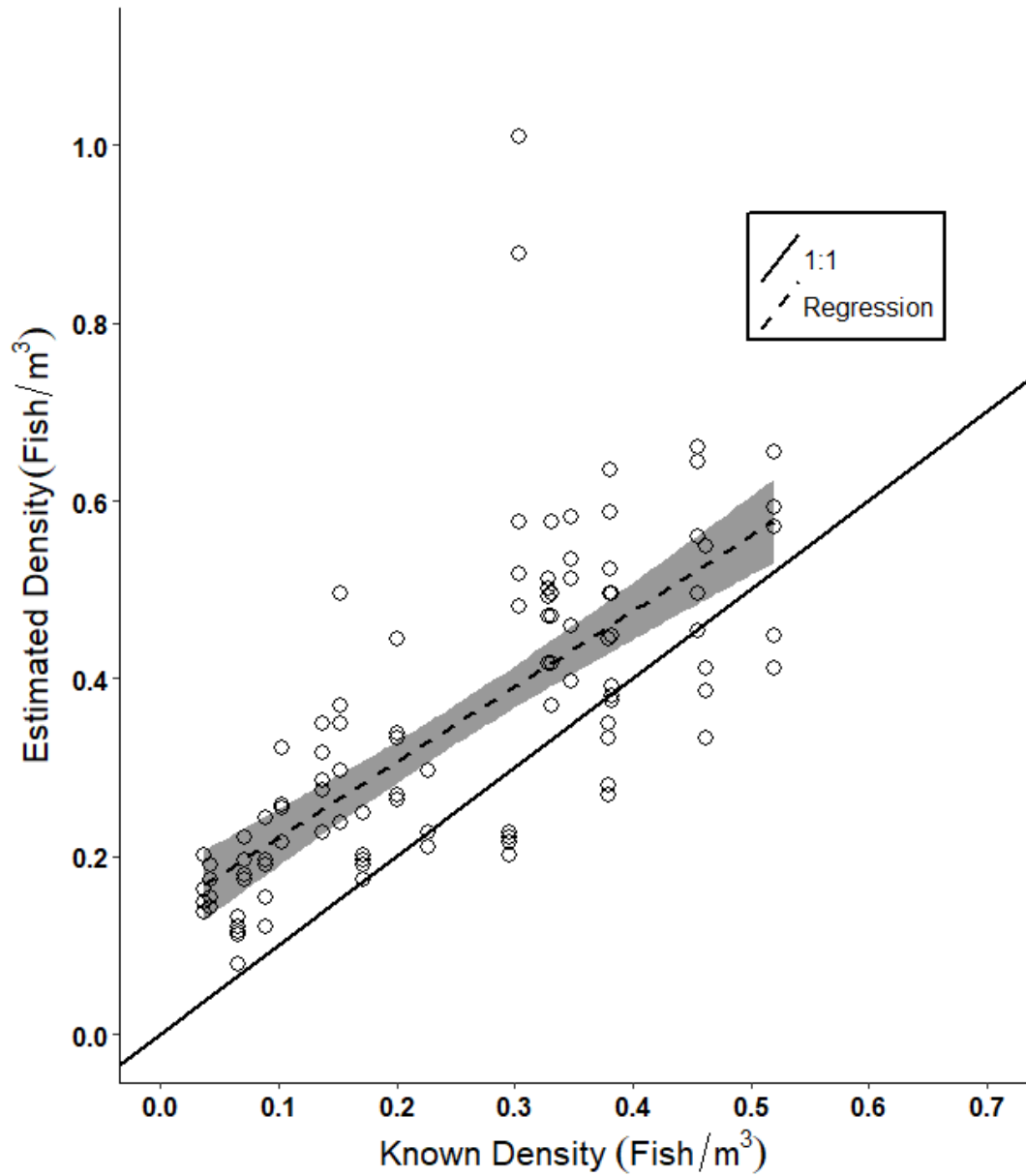

Figure 2. Regression line (dashed line) depicting the change in estimated density (fish/m<sup>3</sup>) at different known fish densities measured with a horizontally-oriented echosounder. Shaded area represents the 95% confidence interval of the slope; solid line is the 1: 1 slope line that would indicate complete accuracy.

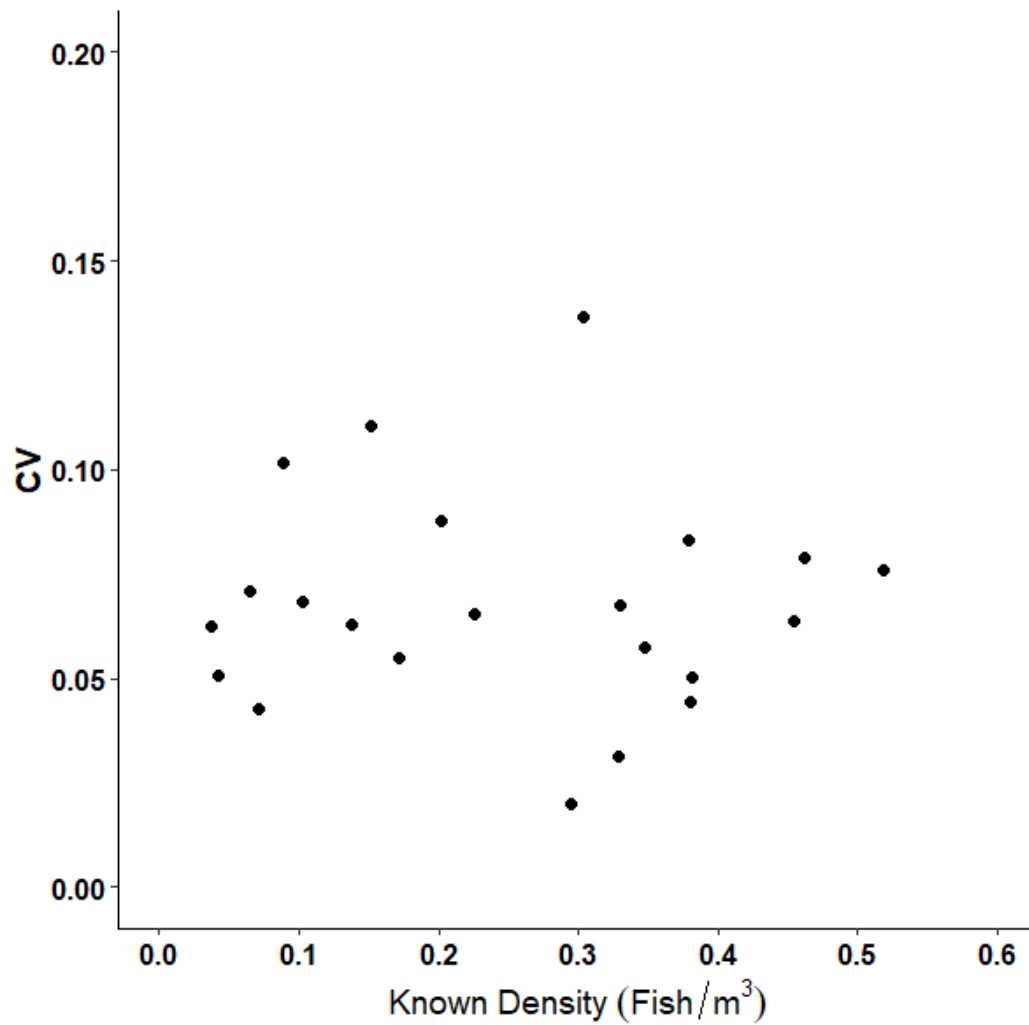

Figure 3. Coefficient of variation (SE/mean) for hydroacoustic density estimates measured at different known Gizzard Shad densities in net pen trials. Coefficients of variation are based on 5 replicate passes of the net with the same fish assemblage.

## CHAPTER III

### HORIZONTAL-ASPECT TARGET-STRENGTH EQUATIONS FOR GIZZARD SHAD *DOROSOMA CEPEDIANUM*: INCORPORATING FISH ORIENTATION INTO TARGET STRENGTH-TOTAL LENGTH EQUATIONS

#### **Abstract**

Horizontally-oriented echosounders have become more common for sampling pelagic prey species in shallow waterbodies, where vertical beaming can be ineffective. Gizzard Shad (*Dorosoma cepedianum*) are an important pelagic prey species in shallow reservoirs. To properly sample Gizzard Shad with horizontally-oriented echosounders, target strength to total length and relationship must be developed to acquire reliable density data. However, when sampling with horizontal beaming, measured TS depends on fish orientation. Currently, a target strength (TS)-total length (TL) equation that is based on TS data from individual fish measured at all orientations is used to convert between TL and measured TS. By assuming all fish encountered in a survey are randomly oriented, each orientation has equal probability of occurring and a mean TS would be representative of all individuals sampled. However, fish may not be randomly oriented for a variety of reasons. Therefore, I developed an orientation-based equation to increase the accuracy of size estimates from direct TS measurements. Target strength measurements were collected from euthanized Gizzard Shad, in a tank, at orientations from 0-180 degrees (0 and 180 being perpendicular to acoustic beam and 90° parallel with head facing the transducer) in five-degree increments. I derived orientation-specific and non-orientation-based TS-TL equations for

Gizzard Shad. A catenary (U-Shape) function best represented the change in TS for at different fish orientations and had a conditional  $R^2 = 0.71$  and marginal  $R^2 = 0.67$ . My orientation-based equation can be used to acquire more accurate Gizzard Shad biomass estimates when orientation information is available. I also compared density estimates from previously published, non-orientation-based  $TS-TL_{Mean}$  equations to determine if equation choice had a significant effect on density estimates from fish aggregations. Equation choice had a significant effect on the resulting density estimates from individual schools ( $P < 0.01$ ), indicating species-specific equations provide greater accuracy.

### **Introduction**

In recent years, the use of horizontally-oriented echosounders for sampling pelagic prey species has become more common in shallow waterbodies where vertical beaming can be ineffective (Simmonds and MacLennan 2008). Vertically-oriented techniques are ineffective in shallow (e.g.,  $< 10$  m) water because they do not sample near-surface or near-substrate areas effectively, resulting in a small volume of water sampled (Thorne 1998; Simmonds and MacLennan 2008). Hypoxic regions caused by thermal stratification can further reduce the portion of the water column available as fish habitat for ensonification (Roberts et al. 2009). The net result is reduced ability to collect meaningful hydroacoustic data in shallow systems. However, horizontally-oriented echosounders shows promise as a potential sampling gear for pelagic prey species in shallow waterbodies because they can efficiently collect large amounts of data and efficiently sample near-surface fish (Thorne 1998).

Gizzard Shad (*Dorosoma cepedianum*) are an important pelagic prey species in shallow reservoirs, so it is important for managers to have accurate Gizzard Shad population data to sustainably manage these systems (Miranda 1983; Carline et al. 1984; Johnson et al. 1988). Currently, gill nets are typically used to collect Gizzard Shad abundance and size structure data for use in fisheries management, a sampling method that is time and labor intensive and imprecise

(Van Den Avyle et al. 1995; Wilde 1995). Horizontally-oriented echosounders may be an alternative to gill nets for Gizzard Shad data collection.

Target strength is an acoustic measurement that is used as a size proxy (i.e. larger TS indicates more reflected sound energy, suggesting a larger scattering surface). When sampling fish with hydroacoustics, target strength (TS)-total length (TL) and target strength-weight (TS-W) equations are used to estimate fish length and weight from TS data. These TS-TL and TS-W equations can have species-specific relationships (Lilja et al. 2000; Frouzova et al. 2005). Use of appropriate mean TS values is imperative to acquiring accurate density and biomass estimates (Traynor et al. 1990). When species-specific TS-TL equations are unavailable, equations derived from similar species or multiple species are used (e.g., Love 1971), which can at times result in inaccurate biomass and density estimates (Traynor et al. 1990; Frouzova et al. 2005). Therefore, Gizzard Shad-specific TS-TL and TS-W equations are important for acquiring reliable population characteristics from horizontally-oriented hydroacoustic data.

Equations used to convert between TS and TL or weight are often used in echo-integration to acquire density and biomass data from fish aggregations that are too dense to detect individual targets. There are two typical outputs when analyzing hydroacoustic data; TS and volume backscattering strength ( $S_v$ ). Target strength is a measurement describing fish length (Simmonds and MacLennan 2008) whereas volume backscattering strength is an acoustic variable that is an integration of scattered energy from multiple targets over a set volume of water (MacLennan et al. 2002) and is used as a biomass proxy (Simmonds and MacLennan 2008). By scaling  $S_v$  by mean TS, a density estimate is calculated. Echo-integration derived density estimates are combined with data from individual targets to acquire total biomass and density estimates for a sampled waterbody.

When sampling with horizontally-oriented echosounders, there is a change in measured target strength (TS) as fish orientation changes (Boswell and Wilson 2008; Rodríguez-Sánchez et al. 2015). For fish that have air bladders, the air bladder reflects 90-95% of the total energy reflected by an individual. Air bladders have an elongate shape that has a smaller ensonified cross-sectional area when the fish faces the transducer than when it is oriented perpendicular to the main axis (Foote 1980; Kubecka and Duncan 1998a). Fish orientation is less problematic with vertical beaming because the dorsal surfaces of sampled fish are almost always ensonified (hence the long axis of the air bladder), unless data are collected during periods of vertical migration (Harden-Jones et al. 1981). Currently, when sampling with horizontally-oriented echosounders, an average TS-TL or TS-W equation is used, where TS is averaged from measurements at all fish orientations (Frouzova et al. 2005). As long as fish orientation is random, a mean TS-TL equation is acceptable and produces minimal bias (Lilja et al. 2000; Boswell et al. 2008). However, fish may not be randomly oriented due to boat avoidance, fish facing into current, migratory movements or schooling patterns (Weihs 1973; Lilja 2004; Draštík and Kubečka 2005). Therefore, incorporating fish orientation into TS-TL equations could increase accuracy of hydroacoustic data analyses in cases where the assumption of random orientation is not met. Kubecka (1994) proposed a model to describe the change of TS with orientation, but the equation only considered a single curve shape and did not account for fish length (Kubečka 1994). Lilja et al. (2000) added fish length to the aspect equation proposed by Kubecka (1994) and derived coefficients for Atlantic Salmon (*Salmo salar*), Pike (*Esox Lucius*) and Whitefish (*Coregonus lavaretus*). However, more potential relationships between measured TS and fish orientation need to be tested before Kubecka (1994)'s equation can be widely used.

There are multiple ways target orientation could be estimated. Early attempts to estimate orientation involved tracking targets on successive pings and recording the largest TS, thus improving chances the fish was perpendicular to the transducer (Ehrenberg and Torkelson 1996).



More recent approaches infer fish orientation from track trajectory as measured by position within the sound cone of split-beam transducers (Rodríguez-Sánchez et al. 2015). There is potential to further refine horizontal data by combining split-beam transducers with multi-beam imaging systems (i.e. ARIS<sup>®</sup> or DIDSON<sup>®</sup>) that can measure fish orientation directly. With these methods to detect fish orientation, TS equations can be developed that more accurately identify fish size from TS measured at any angle.

Horizontally-oriented echosounders may provide more reliable data for Gizzard Shad population characteristics than current sampling methods, but only if fish sizes can be accurately estimated from TS. Development of species-specific TS-TL and TS-W equations can increase accuracy of biomass estimates, but no horizontal TS-TL or TS-W equation exists for Gizzard Shad.

Incorporating target orientation may further increase accuracy of hydroacoustic biomass estimates when orientation information is available. My goal is to develop TS-TL and TS-W equations for Gizzard Shad and then compare my non-orientation-based equations with previously described equations for other species to determine if there was a difference in density estimates among equations when using echo-integration to estimate densities from individual schools.

## **Methods**

Target strength measurements were collected in a 5.5-m diameter tank, filled to 1-m depth, inside the Fisheries and Aquatic Ecology Wet Laboratory (FAEWL) at Oklahoma State University.

Gizzard Shad were collected from nearby Lake Carl Blackwell using boat electrofishing and were transported live in an aerated live tank to the FAEWL. Fish were transferred to an aerated holding tank with a mean water temperature of 22° C (SD =1.65, range 20-25 ° C) and allowed to acclimate for at least 24 h before experimentation.

Hydroacoustic data were collected with a Simrad<sup>®</sup> EK60 split-beam echosounder (See Table 3 for parameter settings) operating at 120 kHz with a 7° beam angle. The transducer was mounted

along the tank wall facing horizontally across the tank at 0.5-m in depth (Figure 4). A pulse duration of 0.256 ms was chosen based on the Great Lakes freshwater sampling protocol (Parker-Stetter et al. 2009). The echosounder was calibrated using a 38.1-mm diameter tungsten-carbide calibration sphere following standard sphere methodology (Foote 1987a). A threshold of -70 dB was used, which was more than adequate to eliminate background noise and echoes from the monofilament line. Measured TS was back-transformed to backscattering cross-section ( $\sigma_{bs}$ ) before all computations ( $\sigma_{bs} = 10^{(TS/10)}$ ).

Forty-seven Gizzard Shad (60-321 mm TL) were euthanized individually prior to each trial using an overdose of Aqui-S 20E and tethered upright, one at a time, to a rotating carousel 4 m from the transducer at a depth of 0.5 m using four strands of 6 lb. monofilament fishing line (Figure 4). The distance of four meters was more than two times the nearfield of the transducer. Individual wet weights (g) and total lengths (mm) were recorded for individuals prior to tethering. Once tethered, fish were positioned at least 1 m from the back wall. The back wall of the tank which was more than twice the pulse length of 0.37 m, had a much stronger TS than tethered fish ( $\geq -10$  dB), and did not interfere with TS measurements allowing for clear separation of the target from the back wall. Underneath the carousel, a horizontal monofilament line was stretched tight along the tank bottom between two cinder blocks that were outside the acoustic beam. Two vertical pieces of monofilament line were used to suspend fish between the carousel and the horizontal line at the tank bottom. One piece of monofilament was threaded through flesh at the dorsal surface of the fish and attached to the carousel, the other was threaded through the ventral surface of the fish and attached to the horizontal line at the tank bottom. Two separate monofilament lines were then threaded through flesh at the mouth and caudle peduncle and connected to the carousel to maintain fish at the desired orientation. All monofilament lines were attached to the fish in a way that did not puncture the air bladder (Figure 4). The rotating carousel was built using a 72-tooth rotating sprocket, allowing for rotation in 5 degree increments. Tethered fish

were centered in the acoustic beam prior to recording. Data were collected at 4 Hz for at least 1 min at each orientation from 0-180 degrees in 5-degree increments (0 and 180 being perpendicular to acoustic beam and 90° being parallel with head facing the transducer) resulting in 36 positions and at least 8,600 TS measurements for each fish.

I derived orientation- and non-orientation-based TS-TL equations and a TS-W equation for Gizzard Shad using the data recorded from tethered fish. Non-orientation-based TS-TL equations were of the form  $a * \log_{10} TL + b$  and a variant of the equation with coefficient  $a$  fixed at 20, as proposed by Foote (1987b). These equations were fit for mean ( $TS_{\text{Mean}}$ ), maximum ( $TS_{\text{Lateral}}$ ) and minimum ( $TS_{\text{Head/Tail}}$ ) of all target strength measurements for individual fish as suggested by Frouzova et al. (2005). Slope and intercepts were tested for significant differences ( $\alpha=0.05$ ) between the basic and Foote (1987b) variant TS-TL relationships for the three pairs of equations (i.e., equations derived from mean, maximum and minimum target strength). Based on the observation that target strength was strongest at 0° and 180° and weakest at 90° (Figure 5), I identified five different functions that create U- or V-shaped curve (Table 4) for developing orientation-specific TS-TL equations. I compared these five functions with three variants of equations proposed by Kubecka (1994), as modified by Lilja et al. (2000) to include TL, and the non-orientation-based equations that were derived from mean target strengths (Table 4).

I fit each equation to TS data from individual fish using maximum likelihood estimation and assessed the most parsimonious equation using AIC. Target strength responses from all fish were fit simultaneously using a linear mixed effects model with fish size ( $\log_{10}(\text{TL})$ ) and orientation (in radians) as fixed factors and individual fish as a random factor (to account for repeated measurements on individuals) using Program R package nlme (Pinheiro et al. 2017). I tested all models with all interaction terms iteratively and removed non-significant interaction terms. Conditional and marginal  $R^2$  values were then calculated to estimate the model fit.

### **Field test of TS-TL equation:**

To test the accuracy of my best orientation-based equation, I paired a Simrad® EK60 120 kHz echosounder with an ARIS® Explorer 1800 imaging SONAR operating at 1.8 MHz and recorded individual Gizzard Shad simultaneously in a natural environment (Lake Carl Blackwell, Stillwater, OK) to examine how well TS-derived fish size estimates matched fish size estimates derived from the imaging sonar. To ensure that only Gizzard Shad data were collected, fish were collected by boat-mounted electrofishing and placed within a nylon net pen (15-m long x 15-m wide x 4.5-m deep with 6.35-mm square mesh) located within the lake. The echosounder data were collected using settings specified in Table 3. Both systems were mounted in tandem on a bracket and lowered to a depth of 1 m within one side of the net pen. The transducers were aimed across the pen and angled 3.5° downward from horizontal to reduce surface noise. During data collection, the boat was pulled along one side of the net. This experiment was conducted at night when shad species are less aggregated, making it easier to measure isolated targets (Schael et al. 1995). Fish length and orientation were estimated using the ARIS® imaging SONAR, capable of collecting high-resolution data (3-mm resolution). During the analysis, both data from the echosounder and the imaging sonar were synchronized in Echoview® 8.1 to facilitate direct comparisons of sampled volumes. I randomly selected 235 fish from the ARIS data by selecting a random starting ping within a recording and selecting the first fish observed after this starting ping. I manually measured the length and orientation of each selected fish from the ARIS® data, then recorded ten TS values from the corresponding fish track observed with the split-beam echosounder. The ten TS values were converted to backscattering cross-section ( $\sigma_{bs} = 10^{\left(\frac{TS}{10}\right)}$ ), averaged and back-transformed to derive a mean TS estimate. I converted the ARIS®-derived lengths to expected TS's using the best performing TS-TL orientation-based equation. Fish orientations were categorized as lateral (perpendicular to transducer; 330° – 30° or 150° – 210), oblique [30° – 60°, 120° – 150°, 210° – 240°, or 300° – 330°], or parallel [facing towards or away

from transducer;  $60^\circ - 120^\circ$  or  $240^\circ - 300^\circ$ ]; Figure 6). I then compared estimated TS (based on ARIS<sup>®</sup>-measured TL and orientation and my regression equation) with measured TS (from the split-beam echosounder) using an ANOVA with estimated TS, length bin (25-mm groupings from 50 to 275 mm TL), and orientation group (lateral, oblique, or parallel) as fixed effects, trial (specific recording/date) as a random effect and measured TS as the response variable using SAS (SAS Proc Mixed; SAS Institute Inc 2017). A total of 235 individual Gizzard Shad of various lengths (60-267 mm) and orientations were analyzed.

#### **Comparison of echo-integration results applying different side-aspect TS-TL equations:**

To compare my non-orientation equations with other published horizontal-aspect equations, I collected data from fish aggregations (multiple individual fish too densely aggregated to detect individual fish tracks) while drifting in Lake Carl Blackwell, Stillwater, Oklahoma using the ARIS<sup>®</sup> imaging SONAR operating at a frequency of 1.8 MHz and the Simrad<sup>®</sup> 120 kHz echosounder operating at a frequency of 10 Hz (table 5). Both transducers were mounted on an aluminum bracket that was angled downward  $3.5^\circ$  from horizontal and lowered to a depth of 1 m. Total length data were collected from all fish in each aggregation using the ARIS<sup>®</sup>. Using these total length data, I calculated a mean TL for each of 23 individual schools. Mean TLs were then converted to a mean TS using each of six TS-TL equations (Table 6). In addition to the two non-orientation based mean TS-TL equations from the current study, I also tested Boswell and Wilson (2008) equations from pooled data for Gulf Menhaden (*Brevoortia patronus*) and Bay Anchovy (*Anchoa mitchilli*), Frouzova's (2005) European pooled freshwater fish equation, and Kubecka's (1994) brown trout (*Salmo trutta*) equation. These six different mean-TS estimates for each school were used to echo-integrate each aggregation, resulting in aggregation density estimates from all 23 aggregations based on each of the six equations. Echo-integrated aggregation densities from each of the six equations were then compared using an ANOVA with TS-TL

equation as a fixed factor and aggregation as a random factor (SAS Proc Mixed; SAS Institute Inc 2017).

## Results

Mean TS of all fish at all measured orientations was -40.11 dB (SD= 7.4) with highest TS frequencies occurring from -45 to -50 dB (Figure 7). Target strength distributions for fish of different sizes had substantial overlap when they had different orientations, even for individuals of vastly different sizes. (Figure 8).

Regression equations for the  $TS_{Lateral}$ ,  $TS_{head/tail}$  and  $TS_{Mean}$  (both with fitted slopes and the Foote (1987b) variant with slope=20) produced significant relationships (Figure 9). For the  $TS_{Mean}$  equations, the slope of fitted-slope equation was significantly higher than the Foote (1987b) variant equation ( $t=2.32$ , d.f.= 91,  $P=0.02$ ), whereas slopes of the Foote (1987b) variants were not significantly different for the  $TS_{Lateral}$  ( $t=1.65$ , d.f.= 91,  $P=0.10$ ) and  $TS_{Head/Tail}$  ( $t=0.62$ , d.f.= 91,  $P=0.53$ ) equations (Table 7). There were no significant differences in intercept between basic and Foote (1987b) variants for  $TS_{Mean}$  ( $t= 1.77$ , d.f.=91,  $P=0.08$ ),  $TS_{Lateral}$  ( $t=0.81$ , d.f.= 91,  $P=0.41$ ) or  $TS_{Head/Tail}$  ( $t=0.33$ , d.f.= 91,  $P=0.73$ ) equations (Table 7). TS-W relationships from mean, maximum, and minimum TS data had R2 values of 0.85, 0.69, and 0.63 respectively (Table 7).

Measured TS of all fish increased as fish were rotated from head/tail perspective to lateral orientations (Figure 5). The range of TS for individual fish also increased as fish size increased. The best orientation-based model was a catenary function with a significant interaction between the catenary term and  $\log_{10} TL$ , which fit as:

$$TS = \left( -4.57 * 1.58 * \cosh\left(\frac{\theta-90^0}{1.58}\right) \right) + 2.68 * \log_{10} TL + 9.63 * \left( 1.58 * \cosh\left(\frac{\theta-90^0}{1.58}\right) * \log_{10} TL \right) - 83.57$$

(Table 8). The catenary model produced a U-shaped response for individual fish (Figure 10) and formed a U-shape plane that curved upward when all fish sizes are considered (Figure 11). All model parameters were significant and the conditional and marginal  $R^2$  values were 0.71 and 0.67 respectively.

#### **Field test of TS-TL equation:**

The catenary model predicted a significant amount of the variation in TS measured by the split-beam echosounder when orientation and fish length (determined from imaging SONAR) were incorporated ( $F_{1,185}=38.12$ ,  $P<0.01$ ). The catenary function did not produce a significantly different TS estimate for any size class ( $F_{8,185}=1.13$ ,  $P=0.34$ ) or fish orientation ( $F_{2,185}=1.10$ ,  $P=0.33$ ) when compared to the split-beam-measured TS of live individuals (Figure 12), indicating the catenary equation properly accounted for all of the variation in TS related to these two variables.

#### **Comparison of echo-integration results applying different side-aspect TS-TL equations:**

Equation choice had a significant effect on density estimates from individually echo-integrated schools.  $Frou_{Pooled}$  had a significantly higher density estimate than all other equations ( $P<0.01$ , Figure 13).  $John_{All}$ ,  $John_{Foote}$ , and  $Bos_{Pooled}$  had significantly greater density estimates than  $Bos_{Foote}$  and  $Kub_{All}$ , but less than  $Frou_{Pooled}$  (Figure 13). Density estimates using the  $Frou_{Pooled}$  equation were almost twice as large as any other equation (Figure 13).

### **Discussion**

I developed a side-aspect equation that predicts TS using TL and fish orientation that could improve density estimates for Gizzard Shad from horizontal echosounders when fish orientation is known or can be measured. One previous attempt to develop an orientation-specific TL-TS equation has been published (Kubečka 1994). This study found a  $\cos^3$  function best described the

effect of fish orientation on TS for a single size of fish (Kubečka 1994). Lilja et al. (2000) added TL to Kubečka (1994)'s aspect model and calculated coefficients for Atlantic Salmon, pike and whitefish. These studies did not consider other functions (other than changing the exponent on the cosine function). I tested 6 different functions and found a catenary function was considerably more parsimonious than the  $\cos^3$  function used by these previous studies. My new equation will provide more accurate Gizzard Shad TL estimates than non-orientation equations when orientation information is available.

There are multiple ways to acquire orientation information required by my equation. First, orientation can be estimated by movements of a target on an x-z plane, tracked using a split-beam echosounder (Rodríguez-Sánchez et al. 2015). This approach does not estimate instantaneous orientation, but infers orientation based on linear movements of a target track over time (Rodríguez-Sánchez et al. 2015). This idea has also been implemented with a dual-beam echosounder and was able to estimate the slope of a moving fish (mm/ping) by using change in range from a fixed transducer (Kubečka and Duncan 1998b). A second approach, which I used when validating my orientation-based-equation, is pairing an imaging SONAR with a split-beam echosounder. Imaging SONARs can estimate orientation of individual fish that are solitary as well as fish at the edge of aggregations by calculating the range difference from end to end of a target (Rose et al. 2005). Because fish aggregations often consist of similar-sized individuals, size estimates of fish distributed along the periphery of an aggregation can be representative of individuals comprising the aggregations (Hoare et al. 2000). Therefore, collecting orientation information from the edge of aggregations with an imaging SONAR may also be a viable method of collecting target orientations. However, the range of imaging SONAR will restrict the use of this method to the first 15 m. These approaches can be implemented during hydroacoustic surveys to measure fish orientation for use in my orientation-based equation.



When orientation information is unavailable, a  $TS_{\text{Mean}}$ ,  $TS_{\text{Lateral}}$ , or  $TS_{\text{Head/Tail}}$  equation should be used, depending on whether orientation can be assumed. For example, when fish orientation can be assumed to be lateral (i.e. migratory movements within a river with transducer oriented perpendicular to river flow) or in the head-tail aspect (boat avoidance or other situation with fish moving toward or away from the transducer), the  $TS_{\text{Lateral}}$  or  $TS_{\text{Head/Tail}}$  equations, respectively, may produce appropriate fish sizes (Burwen and Fleischman 1998; Draščík and Kubečka 2005; Pedersen et al. 2009). This approach has been commonly used in riverine environments in the past (Burwen and Fleischman 1998; Thorne 1998). My orientation-based equation may also be suitable in these situations, but may not be as reliable because the curve fit compensated for all orientations whereas  $TS_{\text{Lateral}}$  and  $TS_{\text{Head/Tail}}$  equations were derived solely from lateral and head-on data. However, when orientation information is unavailable and orientation is assumed to be random,  $TS_{\text{Mean}}$  equations can be used to estimate biomass and density. Therefore, my Gizzard Shad TS-TL equations could be applied in various sampling situations.

Based on the recommendations of Foote (1987b), I derived two forms of each TS-TL equation ( $TS_{\text{Mean}}$ ,  $TS_{\text{Lateral}}$  and  $TS_{\text{Head/Tail}}$ ), a basic model with fitted slope, and a Foote (1987b) variant with a slope fixed at 20 (to facilitate comparison among equations for different species). In most cases (i.e.,  $TS_{\text{Lateral}}$  or  $TS_{\text{Mean}}$  equations), both forms of these equations performed similarly and either equation is applicable. Only the  $TS_{\text{Mean}}$  equation produced significantly different results between the base and Foot (1987b) variants. In this case, the basic ( $a$  is allowed to vary) equation should be used to better describe the relationship between Gizzard Shad size and TS.

Many equations have been proposed to predict average TS for individual species or groups of species, but only limited comparisons have been made between equations (Frouzova et al. 2005; Boswell et al. 2008; Godlewska et al. 2012). I found that TS-TL equation can have a significant effect on density estimates of individual schools illustrating the need for species-specific equations to ensure estimates are accurate from hydroacoustic surveys. Using an inappropriate

TS-TL equation during acoustic surveys could result in inaccurate conclusions resulting in poor management decisions. Therefore, it is beneficial to derive species-specific TS-TL equations to ensure proper TS-TL conversions are applied to hydroacoustic data, especially when data is used in making management decisions.

There are many other factors that can influence measured TS besides orientation in the x-z plane and TL (i.e., changes in swim bladder sound reflectance) that must be acknowledged (Foote 1980; Ona 1990; Kubečka 1994). Fish behavior such as vertical migrations (Harden-Jones et al. 1981; Vabø et al. 2002; Knudsen and Gjelland 2004) and boat avoidance behaviors (Vabø et al. 2002; Draščík and Kubečka 2005) can have an effect on measured TS by changing fish tilt and roll (Love 1977; Nakken and Olsen 1977; McQuinn and Winger 2003). These factors can influence the TS of individual fish, but when averaged over an entire survey, these differences are likely minimized (Fedotova and Shatoba 1983; MacLennan et al. 1989). Fish physiology such as fat content, gonadal maturity, method of airbladder inflation (i.e. physostome vs physoclist), ontogeny, and stomach content can effect measured TS (Foote 1987b; Ona 1990; Ona et al. 2001; Horne 2003). Therefore, fish of similar size and orientation can have different measured TS's and these potential sources of variability must be acknowledged when applying TS-TL relationships.

Derivation of orientation-based side-aspect TS-TL equations can provide increased accuracy of biomass estimates from horizontally-oriented hydroacoustic surveys when orientation information is available. My non-orientation based equations can also be used as a more accurate equation for Gizzard Shad in various situations when orientation information is not available. Species-specific TS-TL equations should be used when available to ensure estimates are reliable. When species-specific equations are not available, caution should be taken when selecting TS-TL equations because equation choice can have a significant effect on estimates. I recommend the use of species-specific, orientation-based equations when possible, but non-orientation equations can also be useful in some circumstances.

## References

- Boswell, K. M., M. D. Kaller, J. H. Cowan Jr, and C. A. Wilson. 2008. Evaluation of target strength–fish length equation choices for estimating estuarine fish biomass. *Hydrobiologia* 610(1):113-123.
- Boswell, K. M., and C. A. Wilson. 2008. Side-aspect target-strength measurements of bay anchovy (*Anchoa mitchilli*) and Gulf menhaden (*Brevoortia patronus*) derived from ex situ experiments. *ICES Journal of Marine Science* 65(6):1012-1020.
- Burwen, D. L., and S. J. Fleischman. 1998. Evaluation of side-aspect target strength and pulse width as potential hydroacoustic discriminators of fish species in rivers. *Canadian Journal of Fisheries and Aquatic Sciences* 55(11):2492-2502.
- Carline, R. F., B. L. Johnson, and T. J. Hall. 1984. Estimation and interpretation of proportional stock density for fish populations in Ohio impoundments. *North American Journal of Fisheries Management* 4(2):139-154.
- Draščík, V., and J. Kubečka. 2005. Fish avoidance of acoustic survey boat in shallow waters. *Fisheries Research* 72(2):219-228.
- Ehrenberg, J. E., and T. C. Torkelson. 1996. Application of dual-beam and split-beam target tracking in fisheries acoustics. *ICES Journal of Marine Science: Journal du Conseil* 53(2):329-334.
- Fedotova, T., and O. Shatoba. 1983. Acoustic backscattering cross section of cod averaged by sizes and inclination of fish. *FAO Fisheries Report (FAO)*.
- Foote, K. G. 1980. Importance of the swimbladder in acoustic scattering by fish: a comparison of gadoid and mackerel target strengths. *The Journal of the Acoustical Society of America* 67(6):2084-2089.
- Foote, K. G. 1987a. Calibration of acoustic instruments for density estimation: a practical guide. *Int. Counc. Explor. Sea. Coop. Res. Rep.* 144:57p.
- Foote, K. G. 1987b. Fish target strengths for use in echo integrator surveys. *The Journal of the Acoustical Society of America* 82(3):981-987.
- Frouzova, J., J. Kubecka, H. Balk, and J. Frouz. 2005. Target strength of some European fish species and its dependence on fish body parameters. *Fisheries Research* 75(1):86-96.
- Godlewska, M., J. Frouzova, J. Kubecka, W. Wiśniewolski, and J. Szlakowski. 2012. Comparison of hydroacoustic estimates with fish census in shallow Malta Reservoir–which TS/L regression to use in horizontal beam applications? *Fisheries Research* 123:90-97.
- Harden-Jones, F., P. Scholes, and J. Suomala. 1981. The swimbladder, vertical movements, and the target strength of fish.

- Hoare, D., J. Krause, N. Peuhkuri, and J. G. Godin. 2000. Body size and shoaling in fish. *Journal of Fish Biology* 57(6):1351-1366.
- Horne, J. K. 2003. The influence of ontogeny, physiology, and behaviour on the target strength of walleye pollock (*Theragra chalcogramma*). *ICES Journal of Marine Science* 60(5):1063-1074.
- Johnson, B. M., R. A. Stein, and R. F. Carline. 1988. Use of a quadrat rotenone technique and bioenergetics modeling to evaluate prey availability to stocked piscivores. *Transactions of the American Fisheries Society* 117(2):127-141.
- Knudsen, F. R., and K. Ø. Gjelland. 2004. Hydroacoustic observations indicating swimbladder volume compensation during the diel vertical migration in coregonids (*Coregonus lavaretus* and *Coregonus albula*). *Fisheries Research* 66(2):337-341.
- Kubečka, J. 1994. Simple model on the relationship between fish acoustical target strength and aspect for high-frequency sonar in shallow waters. *Journal of Applied Ichthyology* 10(2-3):75-81.
- Kubecka, J., and A. Duncan. 1998a. Acoustic size vs. real size relationships for common species of riverine fish. *Fisheries Research* 35(1):115-125.
- Kubecka, J., and A. Duncan. 1998b. Diurnal changes of fish behaviour in a lowland river monitored by a dual-beam echosounder. *Fisheries Research* 35(1):55-63.
- Lilja, J. 2004. Assessment of fish migration in rivers by horizontal echo sounding: Problems concerning side-aspect target strength. University of Jyväskylä.
- Lilja, J., T. J. Marjomäki, R. Riikonen, and J. Jurvelius. 2000. Side-aspect target strength of Atlantic salmon (*Salmo salar*), brown trout (*Salmo trutta*), whitefish (*Coregonus lavaretus*), and pike (*Esox lucius*). *Aquatic Living Resources* 13(05):355-360.
- Love, R. H. 1971. Dorsal-aspect target strength of an individual fish. *The Journal of the Acoustical Society of America* 49(3B):816-823.
- Love, R. H. 1977. Target strength of an individual fish at any aspect. *The Journal of the Acoustical Society of America* 62(6):1397-1403.
- MacLennan, D., C. Hollingworth, and F. Armstrong. 1989. Target strength and the tilt angle distribution of caged fish. *Proceedings of the Institute of Acoustics* 11(3):11-20.
- MacLennan, D. N., P. G. Fernandes, and J. Dalen. 2002. A consistent approach to definitions and symbols in fisheries acoustics. *ICES Journal of Marine Science* 59(2):365-369.
- McQuinn, I. H., and P. D. Winger. 2003. Tilt angle and target strength: target tracking of Atlantic cod (*Gadus morhua*) during trawling. *ICES Journal of Marine Science* 60(3):575-583.
- Miranda, L. E. 1983. Average ichthyomass in Texas large impoundments. *Proceedings of the Texas Chapter of the American Fisheries Society* 6:58-67.
- Nakken, O., and K. Olsen. 1977. Target strength measurements of fish. *ICES*.

- Ona, E. 1990. Physiological factors causing natural variations in acoustic target strength of fish. *Journal of the Marine Biological Association of the United Kingdom* 70(1):107-127.
- Ona, E., X. Zhao, I. Svellingen, and J. Fosseidengen. 2001. Seasonal variation in herring target strength. *Herring: expectations for a New Millennium* 461:461-487.
- Parker-Stetter, S. L., L. G. Rudstam, P. Sullivan, and D. Warner. 2009. Standard operating procedures for fisheries acoustic surveys in the Great Lakes.
- Pedersen, G., N. O. Handegard, and E. Ona. 2009. Lateral-aspect, target-strength measurements of in situ herring (*Clupea harengus*). *ICES Journal of Marine Science: Journal du Conseil* 66(6):1191-1196.
- Pinheiro, J., D. Bates, S. DebRoy, and R Core Team. 2017. nlme: Linear and Nonlinear Mixed Effects Models.
- Roberts, J. J., and coauthors. 2009. Effects of hypolimnetic hypoxia on foraging and distributions of Lake Erie yellow perch. *Journal of Experimental Marine Biology and Ecology* 381:S132-S142.
- Rodríguez-Sánchez, V., L. Encina-Encina, A. Rodríguez-Ruiz, and R. Sánchez-Carmona. 2015. Horizontal target strength of *Luciobarbus* sp. in ex situ experiments: Testing differences by aspect angle, pulse length and beam position. *Fisheries Research* 164:214-222.
- Rose, C. S., A. W. Stoner, and K. Matteson. 2005. Use of high-frequency imaging sonar to observe fish behaviour near baited fishing gears. *Fisheries Research* 76(2):291-304.
- SAS Proc Mixed; SAS Institute Inc. 2017. SAS/STAT® 14.3 User's Guide. SAS Institute Inc, Cary, NC.
- Schael, D. M., J. A. Rice, and D. J. Degan. 1995. Spatial and temporal distribution of threadfin shad in a southeastern reservoir. *Transactions of the American Fisheries Society* 124(6):804-812.
- Simmonds, J., and D. N. MacLennan. 2008. *Fisheries acoustics: theory and practice*. John Wiley & Sons.
- Thorne, R. E. 1998. Review: experiences with shallow water acoustics. *Fisheries Research* 35(1):137-141.
- Traynor, J. J., N. J. Williamson, and W. A. Karp. 1990. A consideration of the accuracy and precision of fish-abundance estimates derived from echo-integration surveys. *Rapports et Proces-Verbaux des Reunions. Conseil International pour l'Exploration de la Mer* 189:101-111.
- Vabø, R., K. Olsen, and I. Huse. 2002. The effect of vessel avoidance of wintering Norwegian spring spawning herring. *Fisheries Research* 58(1):59-77.

- Van Den Avyle, M. J., J. Boxrucker, P. Michaletz, B. Vondracek, and G. R. Ploskey. 1995. Comparison of catch rate, length distribution, and precision of six gears used to sample reservoir shad populations. *North American Journal of Fisheries Management* 15(4):940-955.
- Weih, D. 1973. Hydromechanics of fish schooling. *Nature* 241 290-291.
- Wilde, G. R. 1995. Gill net sample size requirements for temperate basses, shads, and catfishes. Pages 588-595 *in* Proceedings of the Annual Conference Southeastern Association of Fish and Wildlife Agencies.

## Tables

Table 3. Echosounder, transducer and analysis thresholds used in target strength experiments for Gizzard Shad.

<b>System parameters</b>	<b>Value</b>
SIMRAD EK60 split-beam echosounder	
Operating Frequency	120 kHz
Pulse Duration	0.256 ms
Pulse rate	4 Hz
<b>transducer parameters</b>	
Two way beam angle	-20.7
Collection Threshold	-70 dB
Beam width	7°
Nearfield range	0.86 m
<b>Echoview Analysis Threshold</b>	
TS	-70 dB
Single target detector	
Pulse length determination level	6 dB
Minimum normalized pulse length	0.5
maximum normalized pulse length	1.8
Maximum beam compensation	11 dB
Maximum standard deviation of	
Minor axis angle	3°
major-axis angles	3°

Table 4. Names and equations that were compared for estimating target strength using orientation and total length information where TS is estimated target strength, TL is total length in mm, sin is sine, cos is cosine, cosh is hyperbolic cosine, and  $\theta$  is orientation of the ensonified fish in radians. Other symbols are constants fit by maximum likelihood.

<b><i>Model Name</i></b>	<b><i>Equation</i></b>
<b><i>Trig<sub>sin</sub></i></b>	$TS = a * \sin \theta + b * \log_{10} TL + c * (\log_{10} TL * \sin \theta) + d$
<b><i>Trig<sub>both</sub></i></b>	$TS = (a * \cos \theta) + (b * \sin \theta) + c * \log_{10} TL + d * (\sin \theta) * \log_{10} TL + e$
<b><i>Poly<sub>2</sub></i></b>	$TS = a * ((\theta - 90^0)^2) + b * ((\theta - 90^0)) + c * \log_{10} TL + d * ((\theta - 90^0)^2 * \log_{10} TL) + e$
<b><i>Catenary</i></b>	$TS = \left( a * 1.57567 * \cosh \left( \frac{\theta - 90^0}{1.57567} \right) \right) + b * \log_{10} TL + c * \left( a * 1.57567 * \cosh \left( \frac{\theta - 90^0}{1.57567} \right) * \log_{10} TL \right) + d$
<b><i>ABV</i></b>	$TS = a *  (\theta - 90^0)  + b * \log_{10} TL + c * (\log_{10} TL *  (\theta - 90^0) ) + d$
<b><i>Kub</i></b>	$TS = a * \cos 2\theta + b * \log_{10} TL + c * (\cos 2\theta) * \log_{10} TL + d$
<b><i>Kub<sub>3</sub></i></b>	$TS = a * \cos^3 2\theta + b * \log_{10} TL + c * ((\cos^3 2\theta) * \log_{10} TL) + d$
<b><i>Kub<sub>5</sub></i></b>	$TS = a * \cos^5 2\theta + b * \log_{10} TL + c * ((\cos^5 2\theta) * \log_{10} TL) + d$
<b><i>Non-orient</i></b>	$TS = a * \log_{10} TL + b$
<b><i>Foote</i></b>	$TS = 20 * \log_{10} TL + b_{20}$



Table 5. Data collection and analysis thresholds for schools observed during drift surveys in Lake Carl Blackwell, Stillwater, Oklahoma.

<b>System parameters</b>	<b>Value</b>
SIMRAD EK60 split-beam echosounder	
Operating Frequency	120 kHz
Pulse Duration	0.256 ms
Pulse rate	10 Hz
<b>transducer parameters</b>	
Two-way beam angle	-20.7
Collection Threshold	-70 dB
Beam width	7°
Nearfield range	0.86 m
<b>Echoview Analysis Threshold</b>	
TS	-65 dB

Table 6. Names and sources for target strength versus total length equations compared by echo integrating individual schools.

<b>Name</b>	<b>Source</b>	<b>Equation</b>
<b>Lateral all aspect equations</b>		
John <sub>All</sub>	Current study	$23.02 * \text{Log}(\text{TL}_{\text{mm}}) - 93.53$
Frou <sub>pooled</sub>	Frouzova et al. (2005)	$24.26 * \text{Log}(\text{TL}_{\text{mm}}) - 100.68$
BOS <sub>pooled</sub>	Boswell and Wilson (2008)	$14.5 * \text{Log}(\text{TL}_{\text{cm}}) - 60.8$
Kub <sub>ALL</sub>	Kubecka (1994)	$34.1 * \text{Log}(\text{TL}_{\text{mm}}) - 114.3$
<b>Foote 1987 Variants</b>		
BOS <sub>foote</sub>	Boswell and Wilson (2008)	$20 * \text{Log}(\text{TL}_{\text{cm}}) - 65$
John <sub>Foote</sub>	Current study	$20 * \text{Log}(\text{TL}_{\text{mm}}) - 86.42$

Table 7. Regression Coefficients for target strength equations ( $TS = a * \log_{10}(TL) + b$  for length,  $TS = a * \log_{10}(WT) + b$  for weight) derived from ex situ tank experiments for Gizzard Shad (*Dorosoma cepedianum* (n=47, 64-321 mm, 3-223.8 g) at different orientations (Head-on fit data where fish were facing the transducer [90°], Lateral fit data where fish were perpendicular to the transducer [0° and 180°], and Mean fit data from all fish orientations (0 – 180° in 5° increments).  $b_{20}$ -values are from models using a slope fixed at  $a=20$  (Foote 1987). P-value indicates whether slope was significantly different than 1. An asterisk denotes the parameter was statistically different between the two forms of the TS-TL equation.

Orientation	Length					Weight		
	a	P-value	b	$b_{20}$	$r^2/r^2_{b20}$	a	b	$r^2$
Mean	23.02*	<0.01	-93.53	-86.31	0.86/0.86	8.05	-54.74	0.85
Head-on	18.66	<0.01	-98.42	-101.34	0.63/0.63	6.47	-67.37	0.63
Lateral	23.77	<0.01	84.83	-76.59	0.71/0.71	8.16	-45.17	0.69

Table 8. Comparisons of model fits for 8 orientation-based and 1 non-orientation based models for Gizzard Shad data collected in tank experiments.

Model Name	AIC	$\Delta$ AIC	d.f.	Weight
Catenary	9823.77	0	6	0.99
Poly <sub>2</sub>	9836.42	12.6	7	<0.01
Trig <sub>sin</sub>	9873.99	50	6	<0.01
Trig <sub>both</sub>	9875.44	51.4	7	<0.01
ABV	10025.19	200.2	6	<0.01
Kub <sup>3</sup>	10034.47	208.7	6	<0.01
Kub <sup>5</sup>	10077.68	250.3	6	<0.01
Kub	10129.7	304.1	6	<0.01
Non-Orient	11203.47	1372.8	4	<0.01
Foote	11297.56	1473.8	3	<0.01

## Figures

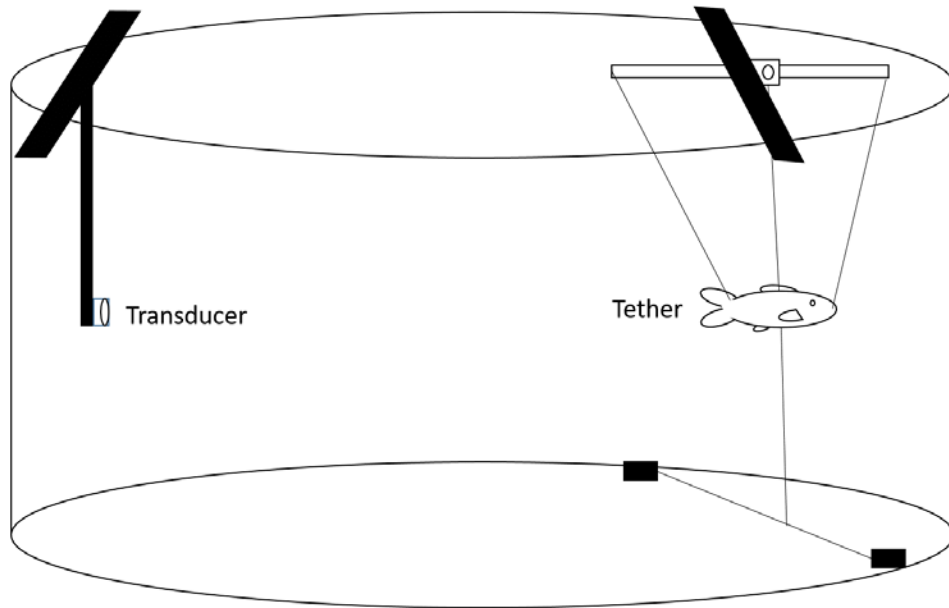

Figure 4. Diagram depicting setup of transducer and tethered fish within pool for ex situ hydroacoustic target strength measurements of Gizzard Shad.

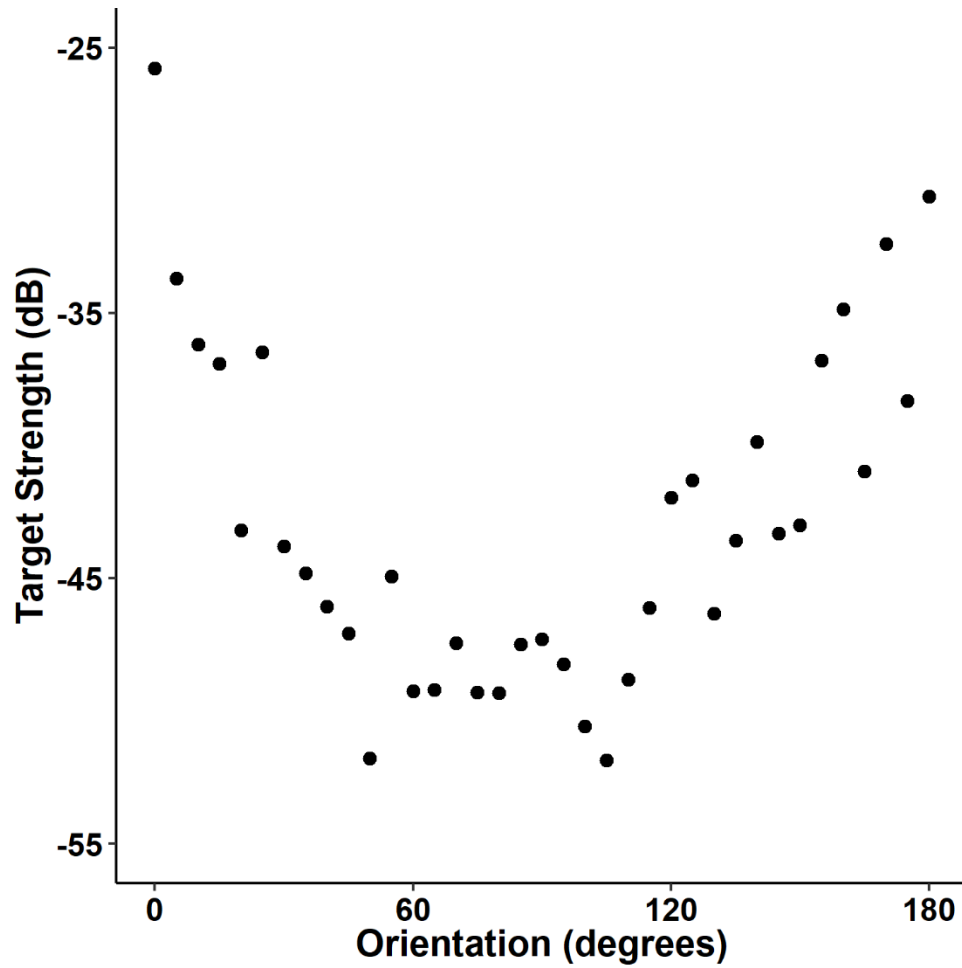

Figure 5. Example of target strength values at orientations ranging from 0-180 degrees (0 and 180 being lateral and 90 being head-on perspective) in 5 degree increments for a 267 mm Gizzard Shad from ex situ experiments.

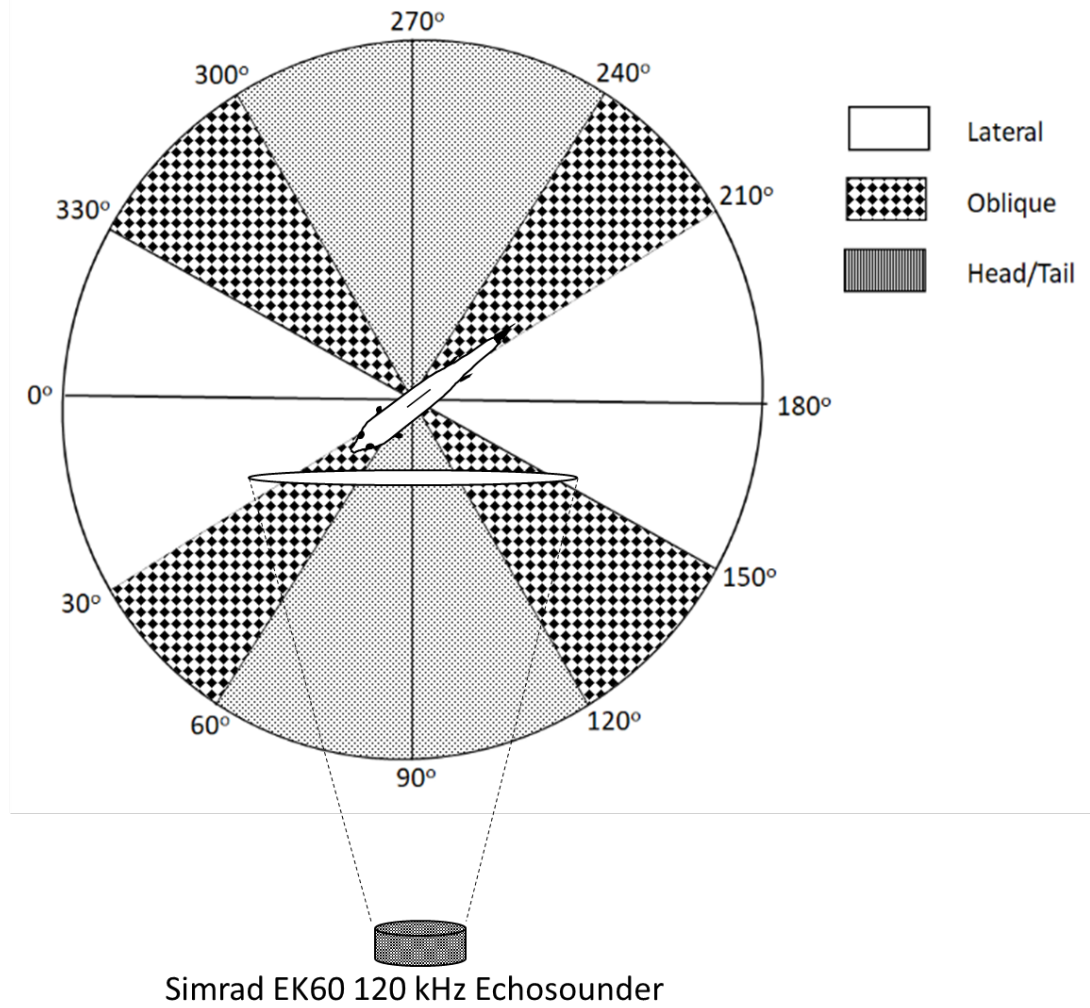

Figure 6. Figure 6. Diagram of fish orientations within acoustic beam. Depicted fish is at an orientation of approximately 35 degrees (oblique category)

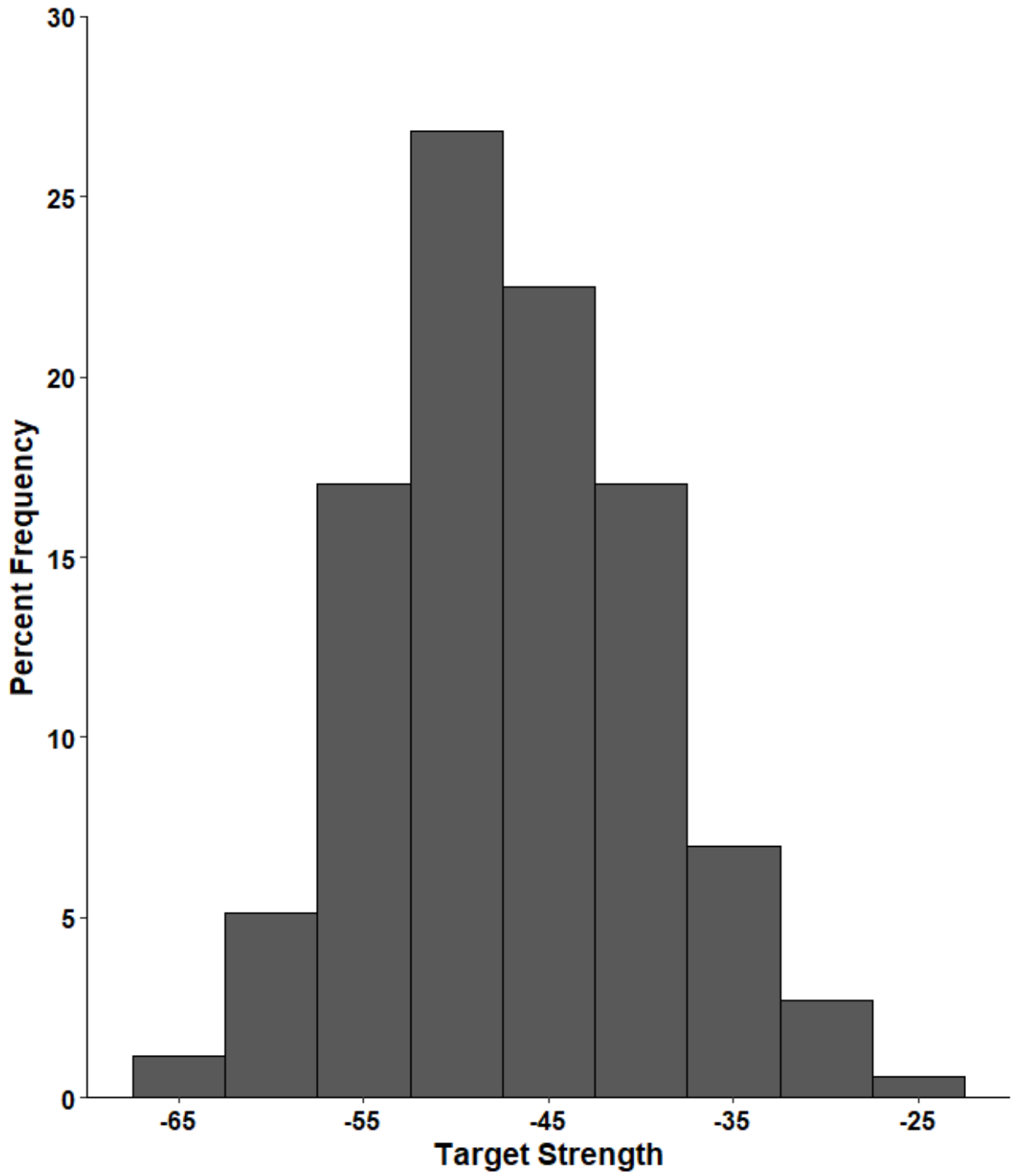

Figure 7. Target strength frequency for Gizzard Shad (n=47,64-321 mm, 3-223.8 g) at orientations from 0-180 degrees (0 and 180 being lateral and 90 being head-on perspective) measured ex situ tank trials.

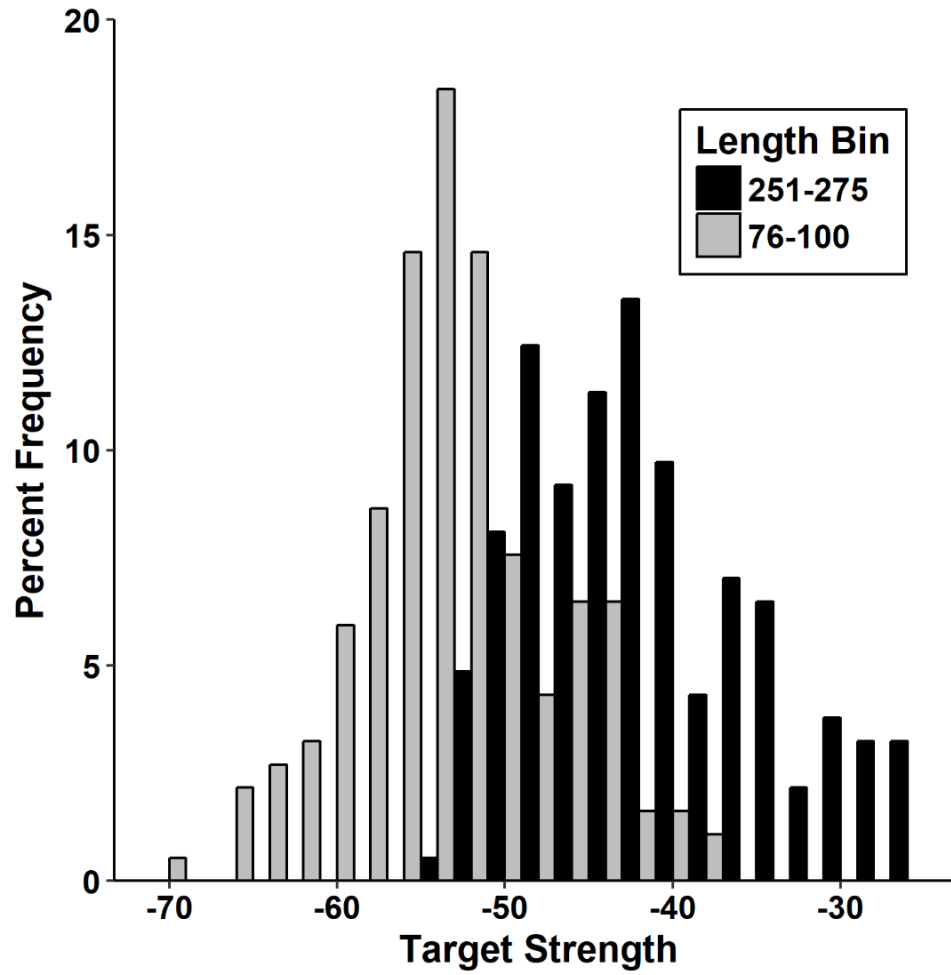

Figure 8. Distributions of TS measurements for Gizzard Shad in the 76-100 mm (n=5 fish, 185 measurements) and 251-275 mm (n=5 fish, 185 measurements) length bins at orientations from 0-180 degrees measured in ex situ tank trials illustrating overlap of measured target strength of large and small Gizzard Shad.

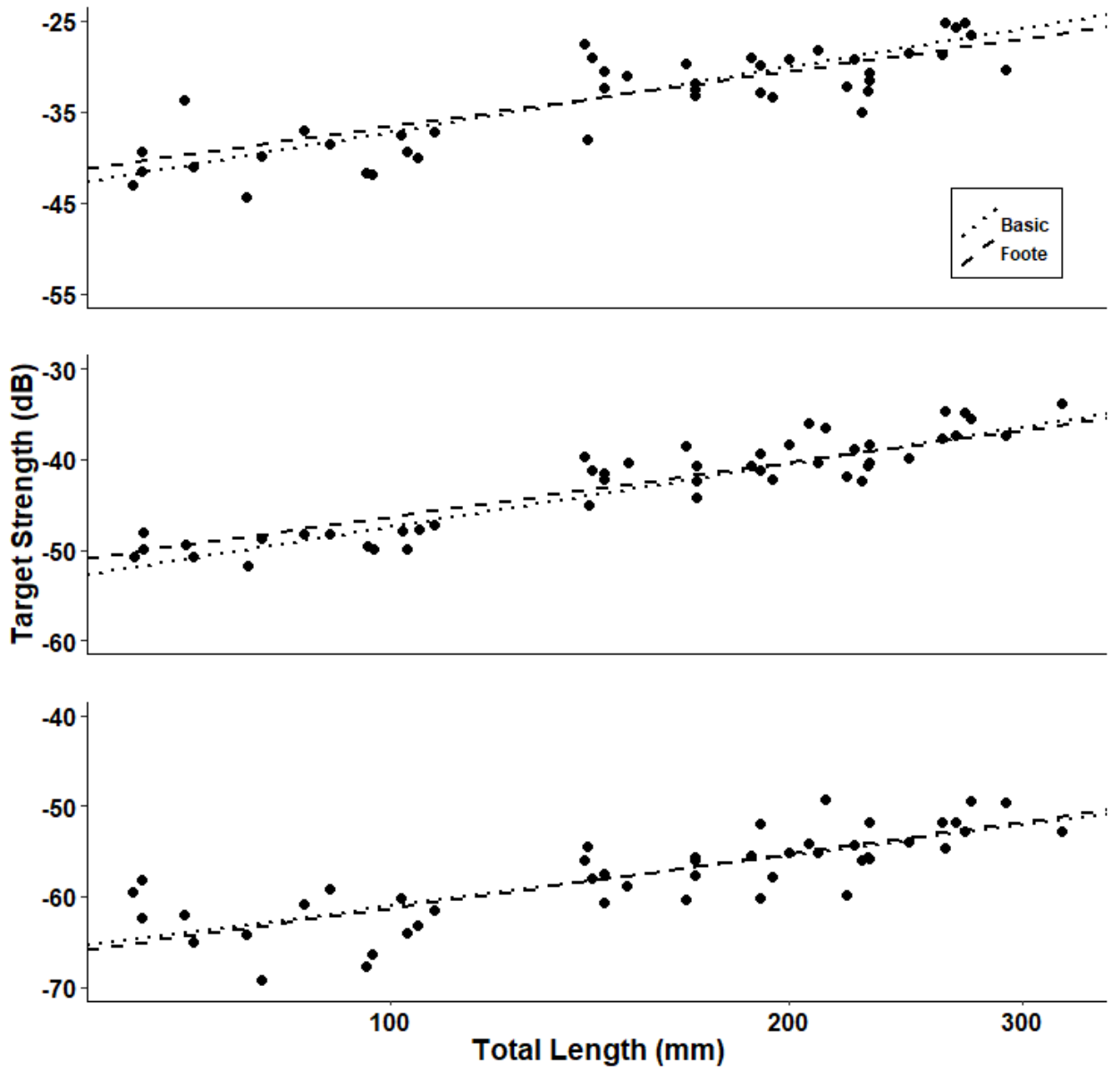

Figure 9. Total length to target strength regressions for lateral aspect, head/tail aspect and average of all orientations allowing the a-coefficient to vary (Basic) and fixing it at 20 (Foote 1987b) for Gizzard Shad (n=47, 64-321 mm, 3-223.8 g).



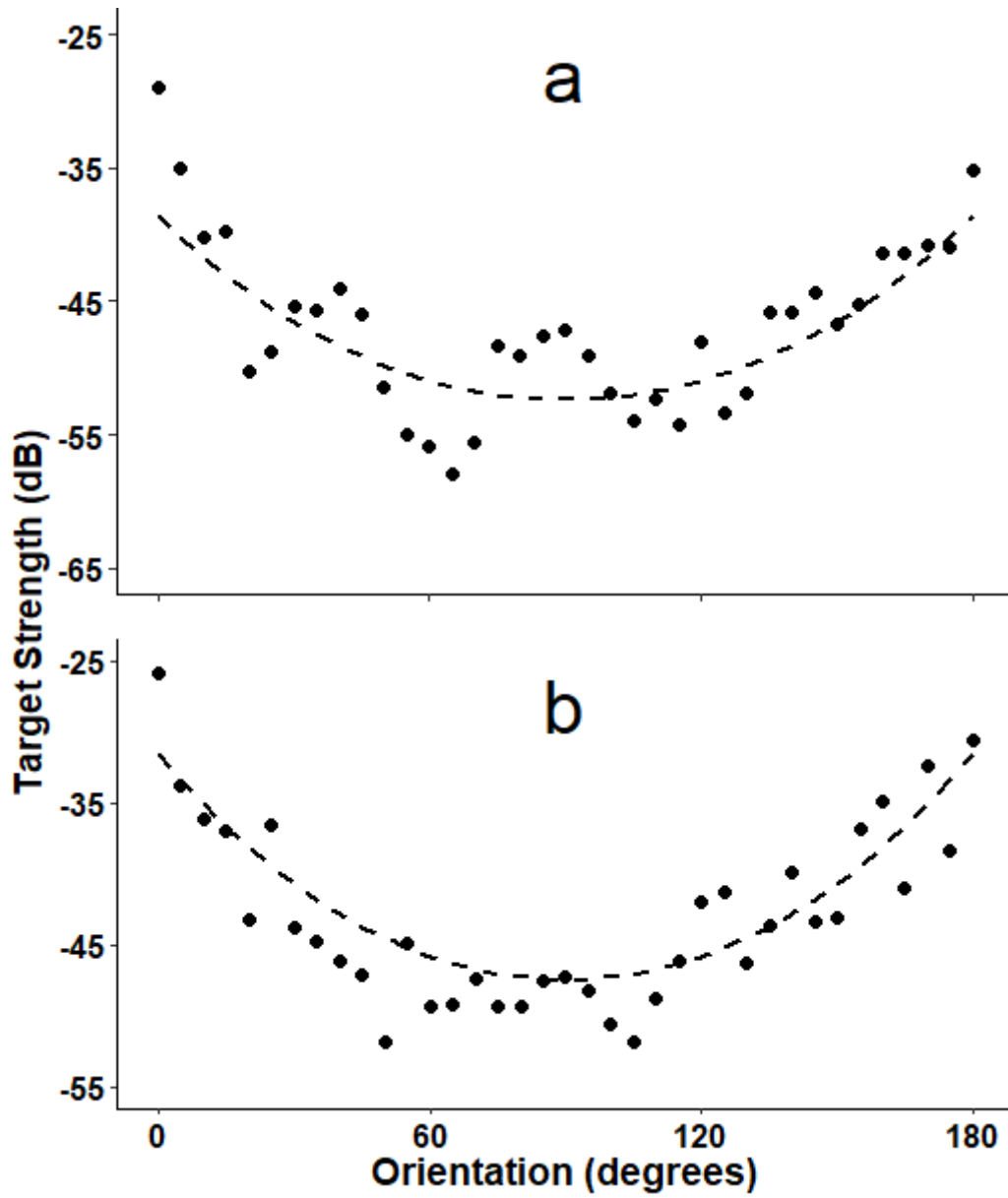

Figure 10. Raw data and modelled catenary equation for a 142 mm (a) and 267 mm (b) Gizzard Shad from data collected in tank trials.

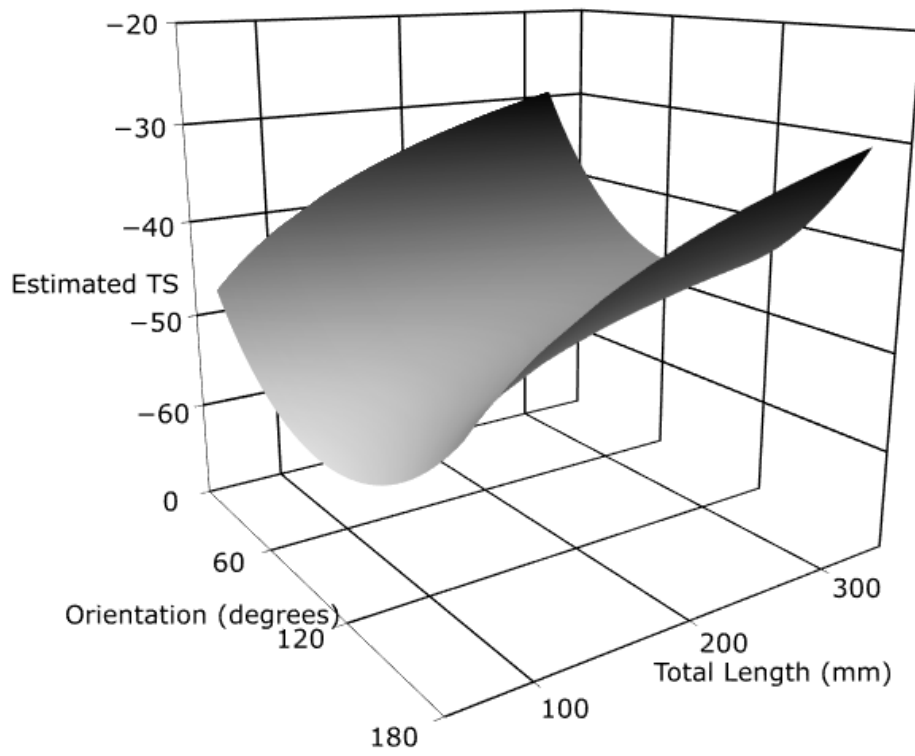

Figure 11. Depiction of the change in expected target strength with changes in total length and orientation modelled using a catenary function derived from data collected from Gizzard Shad in tank trials

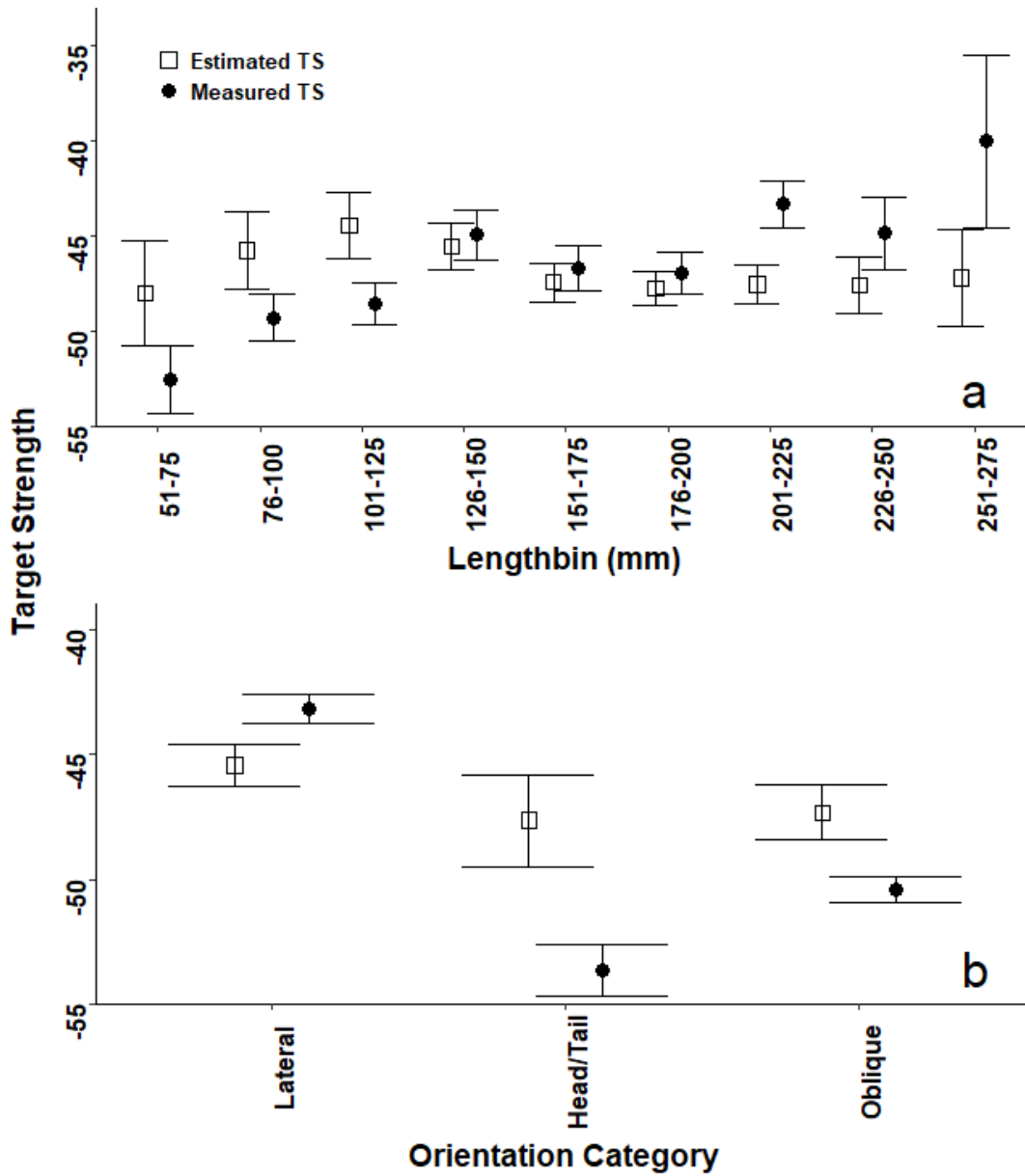

Figure 12. Difference between measured target strength from a Simrad EK60 120 kHz transducer and estimated target strength derived from length and orientation data collected with an ARIS imaging SONAR using my catenary equation.

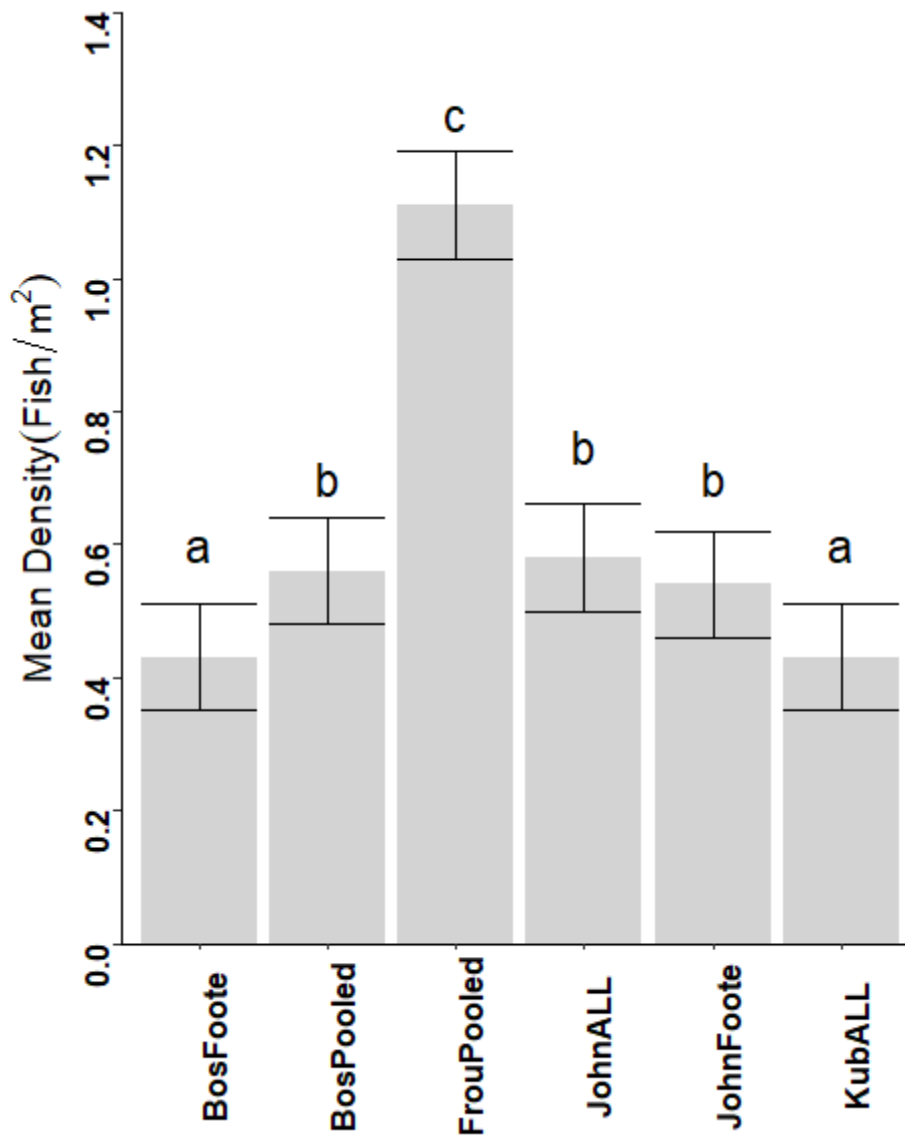

Figure 13. Comparison Comparison of mean school density from 23 schools estimated using six different horizontal-aspect TS-TL equations. In addition to a non-orientation based mean TS-TL equations with random intercept (JohnALL) and a variant with slope fixed at 20 (JohnsFoote) from the current study, I tested Boswell and Wilson (2008) equations from pooled data for Gulf Menhaden (*Brevoortia patronus*) and Bay Anchovy (*Anchoa mitchilli*; BosPooled; BosFoote), Frouzova's (2005) European pooled freshwater fish equation (FrouPooled), and Kubecka's (1994) brown trout (*Salmo trutta*) model (KubALL).

## VITA

Garrett Johnson

Candidate for the Degree of

Master of Science

Thesis: ASSESSING HORIZONTALLY-ORIENTED ACOUSTIC METHODS FOR GIZZARD SHAD ABUNDANCE ASSESSMENTS: ACCURACY, PRECISION AND TARGET ORIENTATION

Major Field: Natural Resource Ecology and Management

Biographical:

Education:

Completed the requirements for the Master of Science in Natural Resource Ecology and Management at Oklahoma State University, Stillwater, Oklahoma in December, 2017.

Completed the requirements for the Bachelor of Science in Fisheries and Water Resources at University of Wisconsin-Stevens Point, Stevens Point, Wisconsin, USA, in May, 2015.

Experience:

- Fall 2015-December 2017, Graduate Research Assistant, Natural Resource Ecology and Management, Oklahoma State University
- Summer 2015, Hatchery Technician, Michigan State University, Onaway, Michigan
- January 2014-May 2015 Laboratory Technician, Wisconsin Fisheries Cooperative Research Unit, University of Wisconsin-Stevens Point.
- Summer 2014, State Worker, Michigan Department of Natural Resources, Escanaba Michigan

Professional Memberships:

- American Fisheries Society