

CEL ANIMATION: SMALL PRODUCTION UNIT CONCEPT

By

JOHN ROGER BOLTON

Bachelor of Fine Arts

University of Tulsa

Tulsa, Oklahoma

1971

Submitted to the Faculty of the Graduate College
of the Oklahoma State University
in partial fulfillment of the requirements
for the Degree of
MASTER OF SCIENCE
July, 1977

Thesis
1977
B694c
cop.2



CEL ANIMATION: SMALL PRODUCTION UNIT CONCEPT

Thesis Approved:

Christine J. Salmon
Thesis Adviser
K. Kay Stewart
Marshall E. Allen
Norman D. Hubbard
Dean of the Graduate College

989105

ACKNOWLEDGMENTS

The greatest reward of working in the area of design is the exchange of attitudes and ideas between individuals. Such has been the case in this design experience. Design is a form of communication, and through communication with many individuals I have strengthened my abilities as an artist and designer.

In acknowledging my appreciation, I wish to express my sincere thanks to Mrs. Christine Salmon, whose patience, enthusiasm, and attitude served as a constant source of inspiration during the course of my studies, and to the other members of my committee: Marshall E. Allen, Associate Professor, Radio-Television-Film, and Dr. Karen Kay Stewart, Associate Professor, Housing, Design, and Consumer Resources. I wish to thank especially my parents for the constant expressions of faith and pride in my abilities, and my mother-in-law and father-in-law for their encouragement. I also wish to thank my undergraduate adviser, Bradley E. Place, Professor and Head of the Art Department, University of Tulsa; with his help and guidance all has been made possible. But most of all I want to express gratitude to my wife, Kathleen, and our three beautiful children, Dana, Brad, and Ryan, for all their love.

TABLE OF CONTENTS

Chapter	Page
I. INTRODUCTION.	1
Visual Perception.	1
Theory of Film Animation	3
Statement of the Problem	6
Purpose.	7
Procedure.	7
II. ANIMATION PROCEDURES.	8
III. ANIMATION EQUIPMENT, ALTERNATIVES AND SOURCES	17
IV. SUMMARY AND CONCLUSION.	40
Summary.	40
Conclusion	40
Recommendations.	41
SELECTED BIBLIOGRAPHY.	42
APPENDIX	
ANIMATION: EQUIPMENT AND SUPPLIES.	43

List of Figures

Figure	Page
1. Animation Storyboard Format	10
2. Camera Exposure Sheet	13
3. Triacetate Cel.	15
4. Animation Pegbars	19
5. Acme, Oxberry, and Signal Corps Registration Pegs . .	20
6. Backlight Units, Commercially Manufactured.	21
7. Light Boxes, Fabrication Plans.	22
8. Backlight Unit, Fabrication Plans	23
9. Animation Disc, Commercially Manufactured	25
10. Animation Disc, Fabrication Plans	26
11. Animation Board with Pegbars.	27
12. Animation Board, Fabrication Plans.	28
13. Animation Board with Animation Disc	29
14. Diagram of an Animation Camera.	31
15. Table Animation Rostrum	33
16. Angle Aluminum Animation Rostrum.	34
17. Tracking Columns for Animation Stand, Fabrication Plans	35
18. Compound Animation Table.	36
19. Compound Animation Table, Fabrication Plans	37
20. Complete Animation Stand, Fabrication Plans	38
21. Complete Animation Stand, Fabrication Plans	39

CHAPTER I

INTRODUCTION

Levitan (1960, p. 9) tells of the animation studio visitor, who after having toured the various departments and seen the many materials and technical aspects involved in the animation process, still had one question, "Yes, but what makes them move?" This question from the novice is quite understandable. It implies that in a study of film animation, there are certain elements preceding the technical and mechanical aspects of execution, that must first be understood in order to fully appreciate the total process.

Visual Perception

Some basic knowledge of the process of visual perception is required by anyone entering into or involved with the study of film animation. We must realize that the techniques used to see and make sense of the variety of visual information in our world is much more complex than we might imagine. Kinsey (1970) states:

If we were asked to describe a scene as it appears through the window of a moving vehicle, say a railway train, we would have little difficulty. It might go something like this: there are hills and a farm in the distance, a road winds its way through the trees that are between the railway and the farm and on this road a man is driving a tractor towards the farm. The sun is setting over the hill.

We would not be in the least disturbed by the fact that because of the motion of the train, the elements composing

the scene were constantly changing their relative positions. . . . The fact that each of our eyes at one and the same time record a scene from a slightly different point of view and therefore receive a slightly different picture and that our eyes are at no time still, even in relation to our head but are constantly moving over or scanning the view in front of us, would not seem to provide us with any difficulties. Indeed so automatic does our perceptive capacity become that many readers will have difficulty in grasping the significance of the foregoing message (p. 15).

Persistence of Vision

The major factor which enables us to make sense of that which we see is the physiological phenomenon of persistence of vision.

Arnheim (1962) reports:

Persistence of vision was first noted in A.D. 130 by Ptolemy, the Egyptian scientist and philosopher. He watched sentries on night duty swing their fire-pots in wide arcs about their heads. When the pot swung slowly, the single flame of the pot appeared to be several separate splashes of flame; but when the pot was twirled quickly, the single flame seemed to fuse into a circle of flame . . . he correctly concluded that the fire-pot was moving too quickly for his eyes to distinguish the progressive stages of the arc.

He could therefore perceive only one continuous movement. Centuries passed before this phenomenon found an application in motion pictures. The development of the art and technology which exploited the persistence of vision laid the basis for animated motion pictures (p. 19).

More clearly described, persistence of vision is the way in which the image of an object is retained on the retina of the eye for a brief instant after the object has been removed (Madsen, 1969, p. 4). Thus the animated film enables a succession of still projected images, shown in rapid succession, to be perceived as one continuous flow of motion.

Conditioned Anticipation

Pittaro (1975) reports, "During the course of our lives we become conditioned to expect that certain actions will have certain results" (p. 23). This conditioning tends to cause us to anticipate what we perceive. If, for example, a person releases his hold on a large round object, we anticipate that the object will fall to the ground. However, if the object floats into space we assume that it must be some sort of gas filled balloon, for we have been conditioned to know that heavy objects do not float. "This characteristic," Pittaro (1975) continues, "is also one of the problems encountered with witnesses in a court of law . . . people simply see in any situation what they expect to see" (p. 23).

According to Halas and Manvell (1963), "A large part of the job of the animator is to play upon the conditioned audience, and, at times, to take part in the conditioning" (p. 59). In Walt Disney's feature length film animation entitled Dumbo, distributed in 1941, the audience as well as the character were conditioned to believe that a very small elephant with very large ears could fly.

Theory of Film Animation

In addition to the physiological and psychological aspects of the animated film, some knowledge regarding the physical and technical nature of the medium is also necessary for comprehension. Since our interest lies in "what makes it work" and not "how to do it," the highly technical and very complicated production process need not be considered at this time.

Film animation, as in every motion picture, may be defined in terms of its physical, optical, and conceptual characteristics. The language and theory of film are derived from these characteristics (Madsen, 1969, p. 23).

Physical Characteristics

Physically, a motion picture is a flexible, transparent length of cellulose triacetate, perforated along one or both edges and bearing a light sensitive coating which enables photographic images to be produced in black and white and color (Kinsey, 1970, p. 16). The processed film can then be projected at the rate of 18 fps (frames per second) silent speed, or 24 fps sound speed. After extensive experimentation, these projection speeds were determined by Warner Brothers in 1927 to be the most suitable (Madsen, 1969, p. 24).

Optical Characteristics

Optically, a motion picture is a series of still photographs that, when projected in rapid succession, at the projection speeds mentioned earlier, create for the viewer an illusion of continuous motion (Madsen, 1969, p. 23). Furthermore, Kinsey (1970) reports,

. . . one important fact which is not generally appreciated is that between the projection of one picture and the next the screen is momentarily blacked out. This allows for the operation of the persistence of vision phenomenon. The eye of the spectator holds the image of one picture or frame, as it is called, while the succeeding image takes its place. If it were not for this blackout between frames, the eye would not be able to accommodate and make sense of the projected images. It is an interesting thought, not generally appreciated by cinema audiences, that for much of the time they are in the cinema they are sitting in total darkness (p. 16).

Conceptual Characteristics

Madsen (1969) states, "The motion picture conceptually, is an orchestration of pictorial concepts, sounds, and movements" (p. 23). The aesthetic organization is, in large part, the responsibility of the artist.

In order to arrange the various pictures, sounds, and movements, the artist must be able to gauge the extent to which his audience will accept stylization of these elements. Halas and Manvell (1963) state:

Characters in film animation must look as they are and behave as they look. Exaggeration and associated simplification are therefore both aesthetically and functionally proper. . . . It is a basic aesthetic principle of cartoon film making that in the case of both animal and human figures, characterization is achieved by the distortion of shapes and forms . . . so long as the link with their original models remains sufficiently clear.

The animator . . . creates a new world of his own on paper, and he has to decide the exact relationship of the creatures of his imagination to all the forces that govern behavior in the world of nature. As soon as he draws a figure on paper and considers its potential movement, he cannot escape these other considerations, for his audience will anticipate that the figure will conform to whatever forces would affect it were it to exist in actuality. It may be his design to exploit this anticipation and give his figure a certain license, for in the world of cartoon, elephants fly and men walk up walls. . . (p. 64).

Kinsey (1970) explains, "the success of an animated film depends on the artist's ability to create his own world, presenting a consistency of style in all the elements of time, character, movement, sound, and background" (p. 17).

Statement of the Problem

Many books and articles have been written dealing with animation in the large creative film unit. Art, animation, and design studios throughout the world employ vast numbers of people and sophisticated equipment to complete their animation needs. Levitan (1960, p. 117), in the conclusion of his book on animation art in the commercial film, tells of the approximately fifty people whose combined talents were needed to produce a one minute television commercial.

Yet much of today's animation is being done, not by the large studio, but rather by the small creative film unit. These units usually consist of a producer, a director, a designer, and sometimes a cinematographer. More precisely, the task of animation is usually handled by the designer.

For the small studio or film unit designer unacquainted with animation, the processes and the equipment, there is no single written source which deals with his specific problems of limited production time, staff, and budget. Rather, many sources must be explored to gather the basic techniques needed.

Little written emphasis has been placed on the solitary designer, who, after thorough study of the materials available, sits quietly huddled over his animation disc, diligently working toward one purpose, to give life to his creation.

One major area remains almost totally unresearched--that of overcoming the monumental costs of animation equipment. Very little has been published regarding designs for building professional quality equipment.

Purpose

The purposes of the study were to:

- 1) explore briefly what makes cel animation work
- 2) define the processes of cel animation
- 3) investigate the possibility of building the equipment necessary for cel animation for the small studio or film unit designer.

Procedure

In developing this study the following steps ensued:

- 1) review of literature
- 2) exploration of cel animation as it pertains to the small creative unit
- 3) development of designs for animation equipment to circumvent the high costs of commercially available equipment.

CHAPTER II

ANIMATION PROCEDURES

Since the small production unit contains a very limited staff, usually only one designer, it follows that animation, with all its complexities and time consuming characteristics, must either be shortened, simplified, or both.

The chief method of simplification is stylization of the chief elements within an animated segment. Each line drawn or detail included may have to be redrawn as many as 24 times for every second of film produced.

Limiting may be accomplished by avoiding all unnecessary or complicated movements unless so specified in the script. For this reason, animation is usually handled in short segments, used generally to visualize that portion of a production not readily shown in any other manner. And although the specific procedures involved in a cel animation of this type may vary, in degrees, from one designer to the next, a general feel for the single designer concept may be derived by first dividing cel animation into two parts, the planning process and the production process.

The Planning Process

The planning process begins with determining what animation is needed within a given production. This generally takes place in

several pre-production meetings between the producer, director, and designer.

In the process of formalizing which segments are to be animated, the general style for the subject and background may also be discussed. Upon completion of this series of meetings, a storyboard can be prepared.

The Storyboard. The storyboard consists of a series of drawings, recording the key action within an animated segment. Verbal comments are written or typed beneath each drawing whenever they might help to clarify the segment pictured (Kinsey, 1970, p. 82). Storyboards are usually drawn on prepared sheets of paper having a number of plain rectangles used to represent individual frames of film (Figure 1).

Generally it serves three major functions. It is a visual test of the idea in abbreviated form to see how it works. It is an outline in graphic form, for the designer to work from when doing further planning, but most important, the style of the segment is developed.

Three determining factors dominate the development of the style for both subject and background: the purpose of the segment, the nature of the subject matter, and the educational background of the target audience (Madsen, 1969, p. 96). It must also be consistent with the overall program style.

Sound Recording, Analysis, and Timing. Since animation deals with drawings that are photographed on individual frames of film, the sound track must also be converted into the same format so a correlation may be drawn between the two. For this reason, all narration

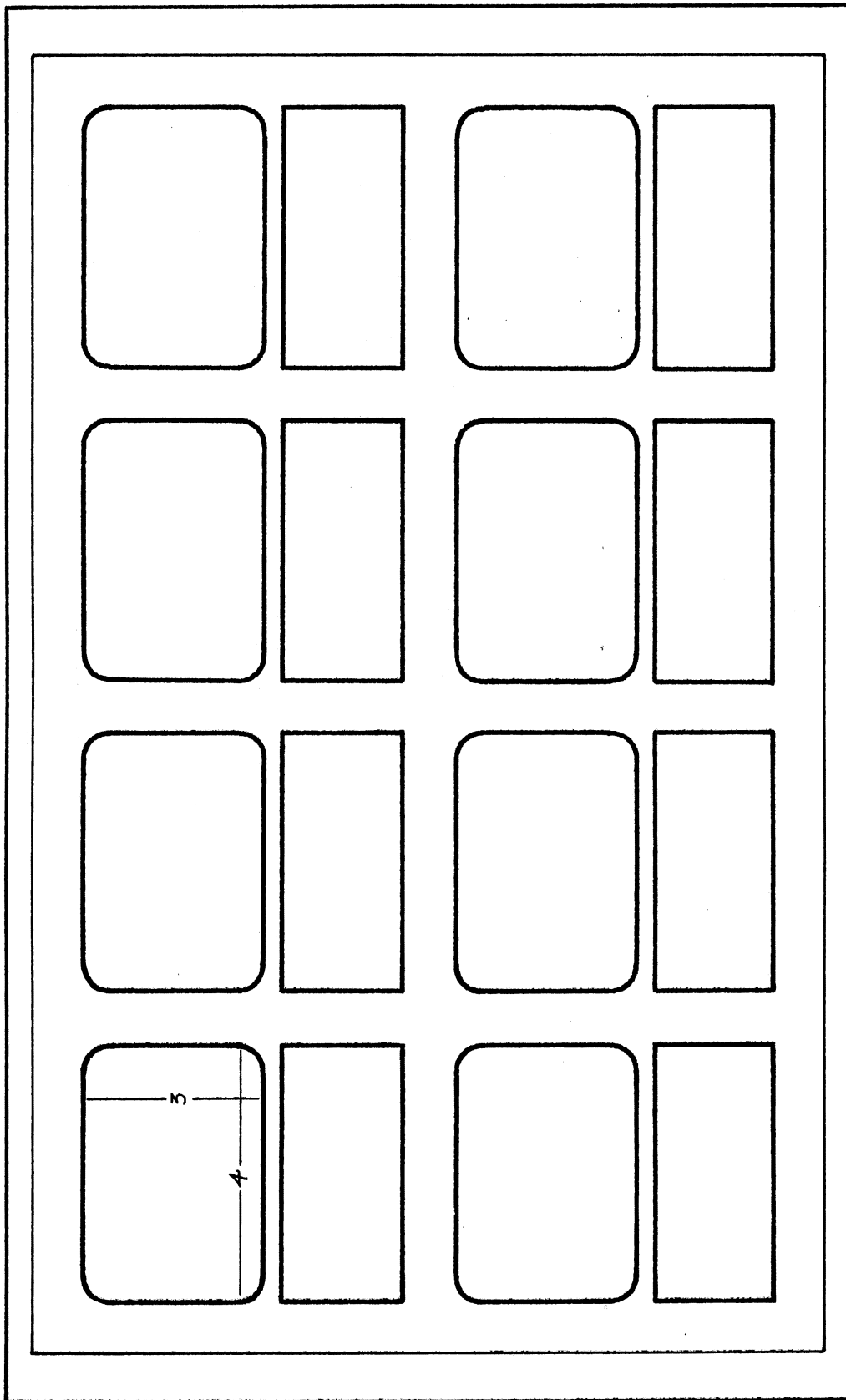

Figure 1. Animation Storyboard Format

and special audio effects are recorded on quarter inch audio tape and then transferred to full coat 16 mm magnetic film, a standard 16 mm cellulose triacetate based film with perforations and completely coated with a magnetic recording medium. Only then can the sound track be analyzed on the sound reader, a playback device used manually to pinpoint specific sounds recorded on 16 mm magnetic film. Accurate written sound analysis is important to insure absolute synchronization of the key actions of the animation with the sound track.

After this step has been accomplished, the designer can time the segments accurately. Because the sound track helps determine the visual information to be presented, the designer can now plan specific actions in the animation to coincide exactly with the sound, frame by frame.

Within every animated segment from inception to the actual production process, each phase of the planning process flows naturally to the next. Ideas expressed verbally in pre-production script conferences determine the visual aspects of the storyboard.

In turn, the storyboard graphically illustrates the style of the subject and background and tests the ideas of the written narrative for their visual continuity.

The sound recording and analysis are then completed to enable the designer to time all actions within a segment, so the actual production process can now begin.

The Production Process

The production of cel animation, by the small unit designer striving for professional results, is basically the same as that of

his counterpart, the large animation studio with unlimited staff and equipment; the chief differences being the amount and the detail of the animation undertaken. Realizing too, that instead of having various individuals or groups assigned to specific functions, he alone must complete all the process.

Extremes and In-between. Remembering that for every action there is a starting and finishing point called extremes, the first function of the designer is to draw these extremes for each action. By following the timing sheets, the number of individual frames "in-between" each extreme can be determined. It is then a matter of determining the desired final speed of the subjects, and drawing the in-between positions, keeping in mind that sound film is projected at a rate of 24 fps. This is usually accomplished by dividing each series in half, drawing the middle position and dividing again. This is continued until all in-between positions have been filled.

During this process, exposure sheets (Figure 2) should also be prepared as a guide to the filming of the finished drawings. Exposure sheets list each frame of animation in a segment and the exact order in which the cels are to be photographed.

Pencil Test. All initial drawings of the animation are done in pencil for maximum efficiency, since minor changes may be required. When all the drawings of a segment are completed, a filmed test must be shot to determine if the action moves smoothly and corresponds to the original style indicated by the storyboard.

PAGE _____

Camera Exposure Sheet

JOB NO. _____ SPOT NO. _____ CLIENT _____

JOB NAME _____ SHOOTING TIME _____

SOUND E V	ACTION	BKGD	CELS				FRAME	CAMERA		
			1	2	3	4		C/H	N/S	E/W
							1			
							2			
							3			
							4			
							5			
							6			
							7			
							8			
							9			
							0			
							1			
							2			
							3			
							4			
							5			
							6			
							7			
							8			
							9			
							0			
							1			
							2			
							3			
							4			
							5			
							6			
							7			
							8			
							9			
							0			
							1			
							2			
							3			
							4			
							5			
							6			
							7			
							8			
							9			
							0			

Figure 2. Camera Exposure Sheet

Examination of the pencil test is done by viewing the projected image. Here it becomes readily evident whether or not the test is satisfactory. If not, corrections must be made and the test process begun again.

Inking. When it is determined that the initial pencil drawings are complete, inking can begin. Each pencil drawing must be individually positioned on the peg bar of the animation disc (discussed in the next chapter), covered with .005 inch triacetate, called a cel (Figure 3), and meticulously traced in ink, using either pen or brush.

From this point in the animation process, it is customary to wear white lintless cotton gloves when handling the cels. This helps avoid as much as possible grease smudges that can present a major problem later.

Opaquing. The general term used to describe the painting or colorizing of a cel is 'opaquing.' In this step, each inked drawing or cel is turned over and the colors are "puddled"; that is, applied thickly and brushed in small circular motions, not stroked on the reverse side, with the inked lines serving as boundaries for the colors. The painted areas must be opaque to obtain the proper brilliance on the front side. Several suitable types of paint are available; the most commonly used, however, is a water base vinyl paint that dries flat, and, once dry, is no longer water soluble.

Checking. When the cels have dried thoroughly, they should be turned to the front side and checked for any irregularities in the opaquing such as paintless areas within the subject boundaries and

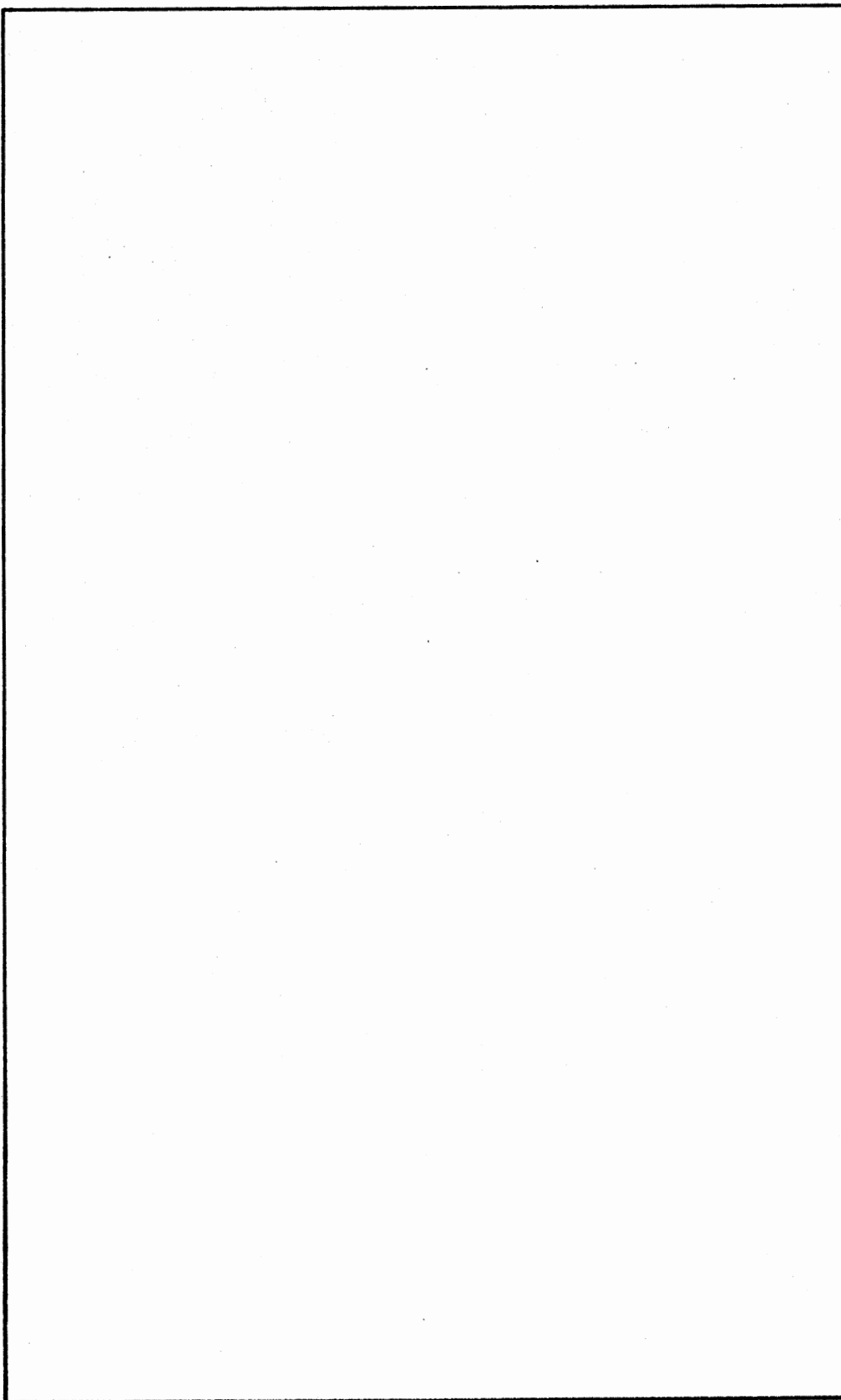

Figure 3. Triacetate Cel

paint overlap outside these boundaries. After checking all cels and arranging them in the proper sequence, the segment is ready to be filmed.

CHAPTER III

ANIMATION EQUIPMENT, ALTERNATIVES AND SOURCES

The animation equipment a designer chooses depends not only on the requirements of the script, but more often on the money available. Severe budgetary limitations often restrict large capital expenditures for the small production unit.

For the small unit designer, various sources and alternatives are available that can curtail a significant portion of the monumental expense involved in initiating cel animation at the professional level.

As stated by Kinsey (1970):

Obviously in a market as limited and specialized as this, equipment costs are bound to be high. . . . But the reader who is anxious to set himself up with fully professional equipment . . . is patient, ingenious and in possession of some electrical and mechanical knowledge can . . . put together a very satisfactory animation machine (p. 24).

To define these sources and alternatives, a study of the equipment necessary is required.

The equipment for cel animation generally falls into two categories: production equipment and photographic equipment. Production equipment consists of those accouterments used in the preparation of drawings, cels, and associated art. The photographic equipment is used to accurately transfer a series of images on cels, to individual frames of film, for the purpose of creating motion.

Registration Pegs

When establishing production equipment, the initial items to consider are the registration pegs, often referred to as the animation pegbar since the pegs are affixed to a metal bar (Figure 4). Registration pegs are used to maintain precise registration of the drawings and cels throughout the animation process. And although it is possible to have the pegs machined, it is as economical and much less time consuming to purchase this equipment from the manufacturer.

Three types of peg systems are commercially available in the United States. The Acme system, the Oxberry system, and the Signal Corps system (Figure 5) offer the precise registration needed, with only slight dimensional differences.

The Light Box

The light box (Figures 6, 7, and 8) is used as a source of back-light during the entire production process. It consists of a container or housing that holds a light. Fluorescent light is used in many instances due to the intense heat buildup of incandescent fixtures.

The Animation Disc

The animation disc is a flat circular device, equipped with pegbars, used to register and rotate the animation drawings during the production process. The center area between pegbars is cut out and covered with a frosted glass or plexiglas insert to facilitate backlighting.

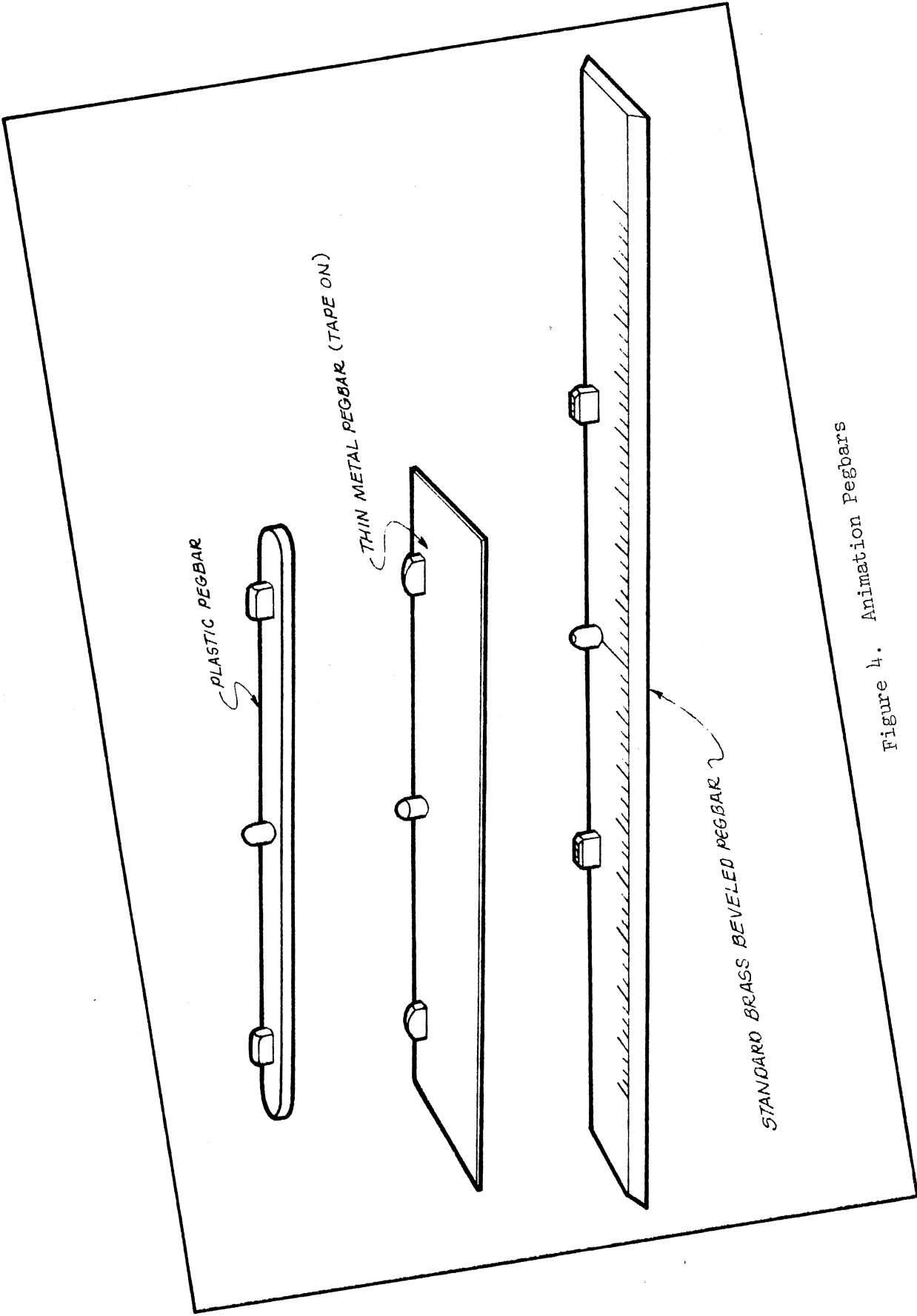

Figure 4. Animation Pegbars

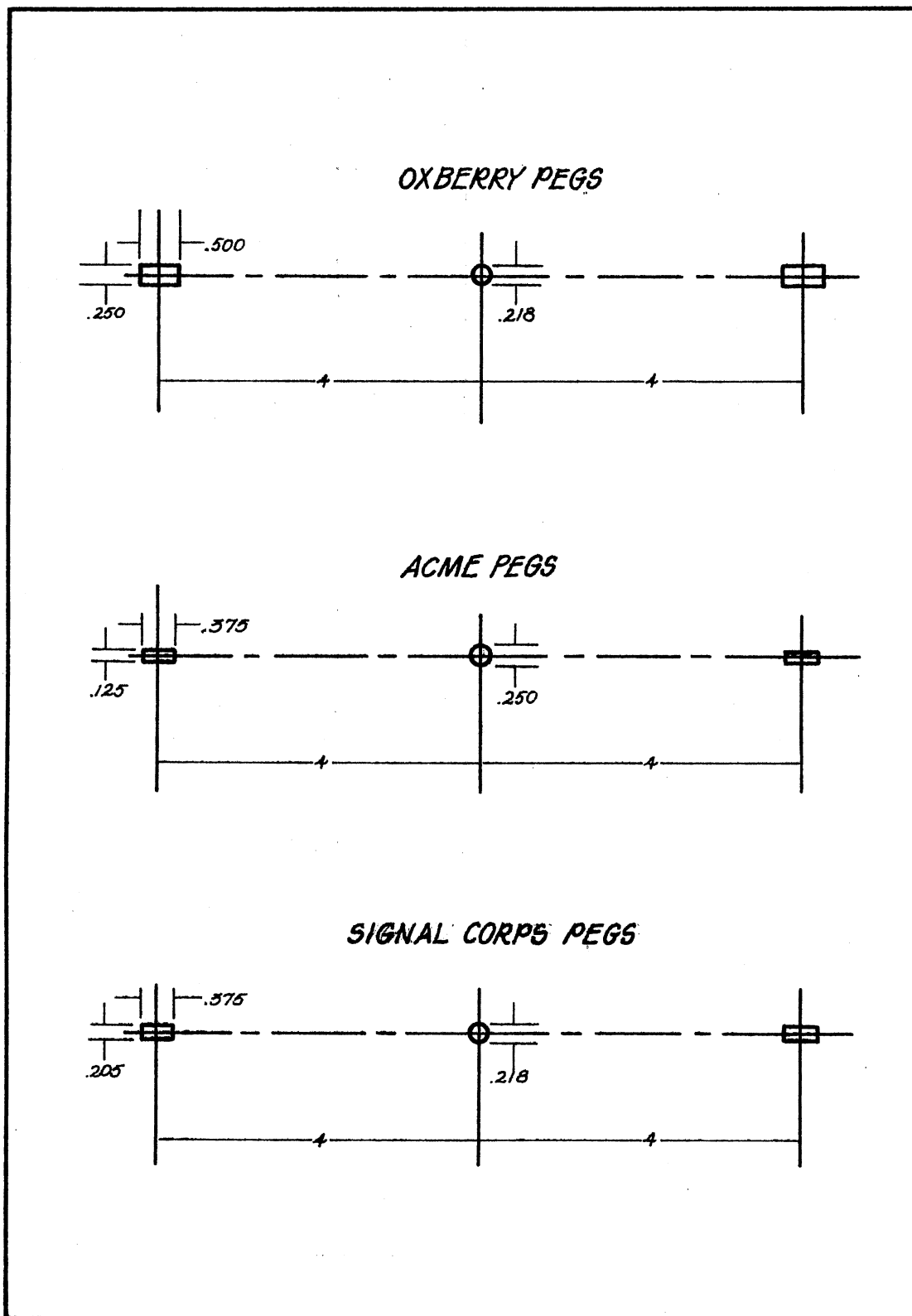

Figure 5. Acme, Oxberry, and Signal Corps Registration Pegs

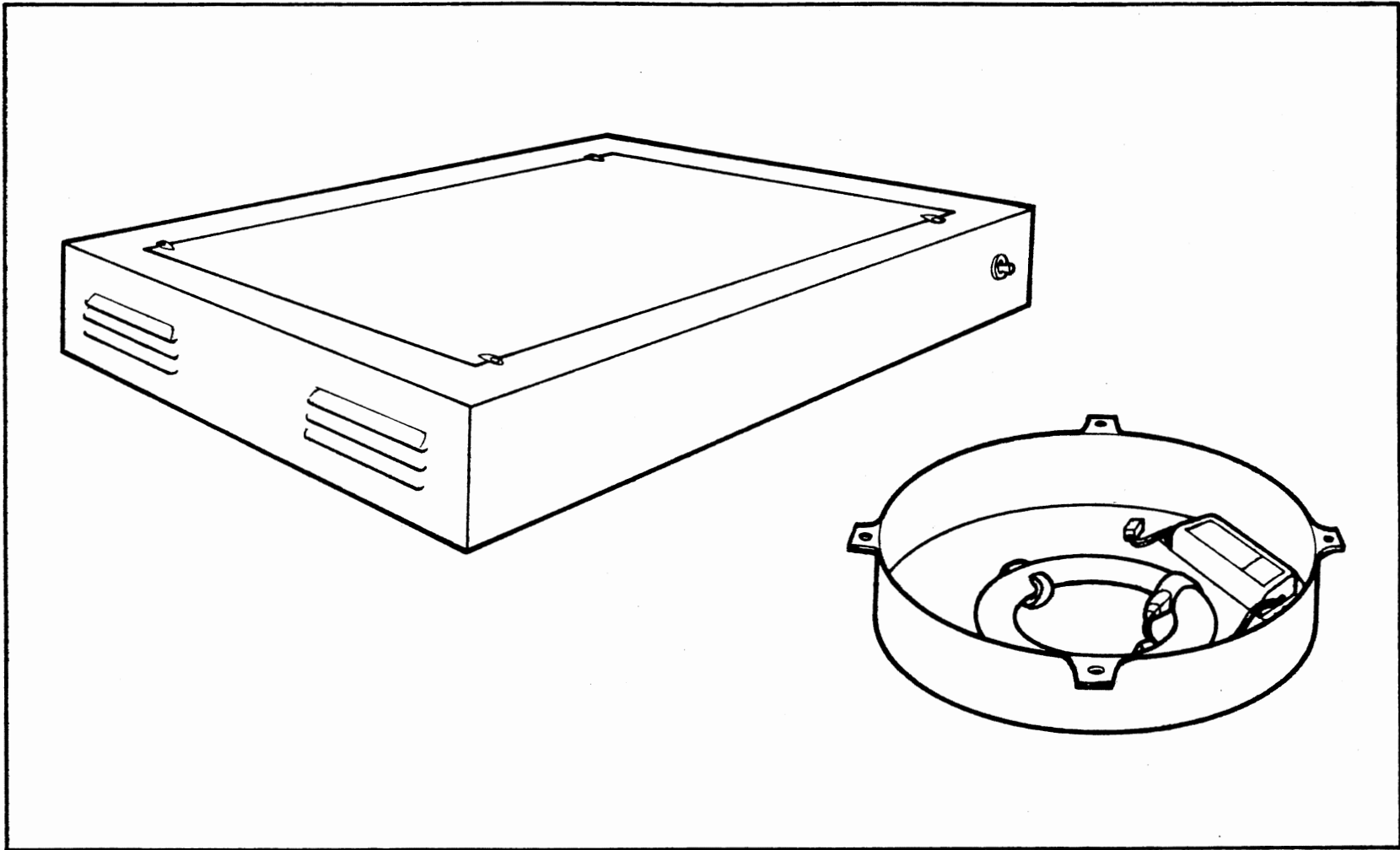

Figure 6. Backlight Units, Commercially Manufactured

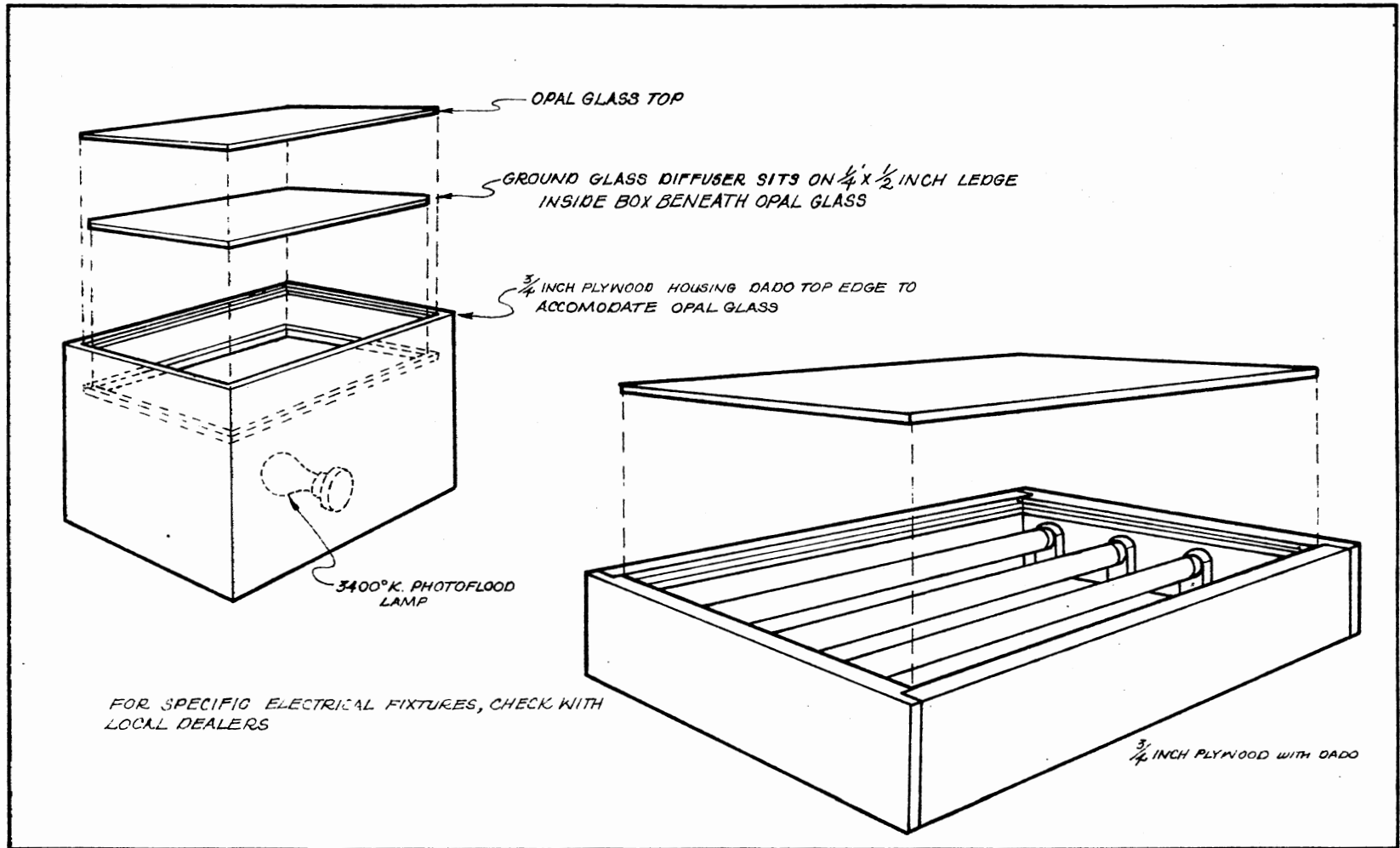

Figure 7. Light Boxes, Fabrication Plans

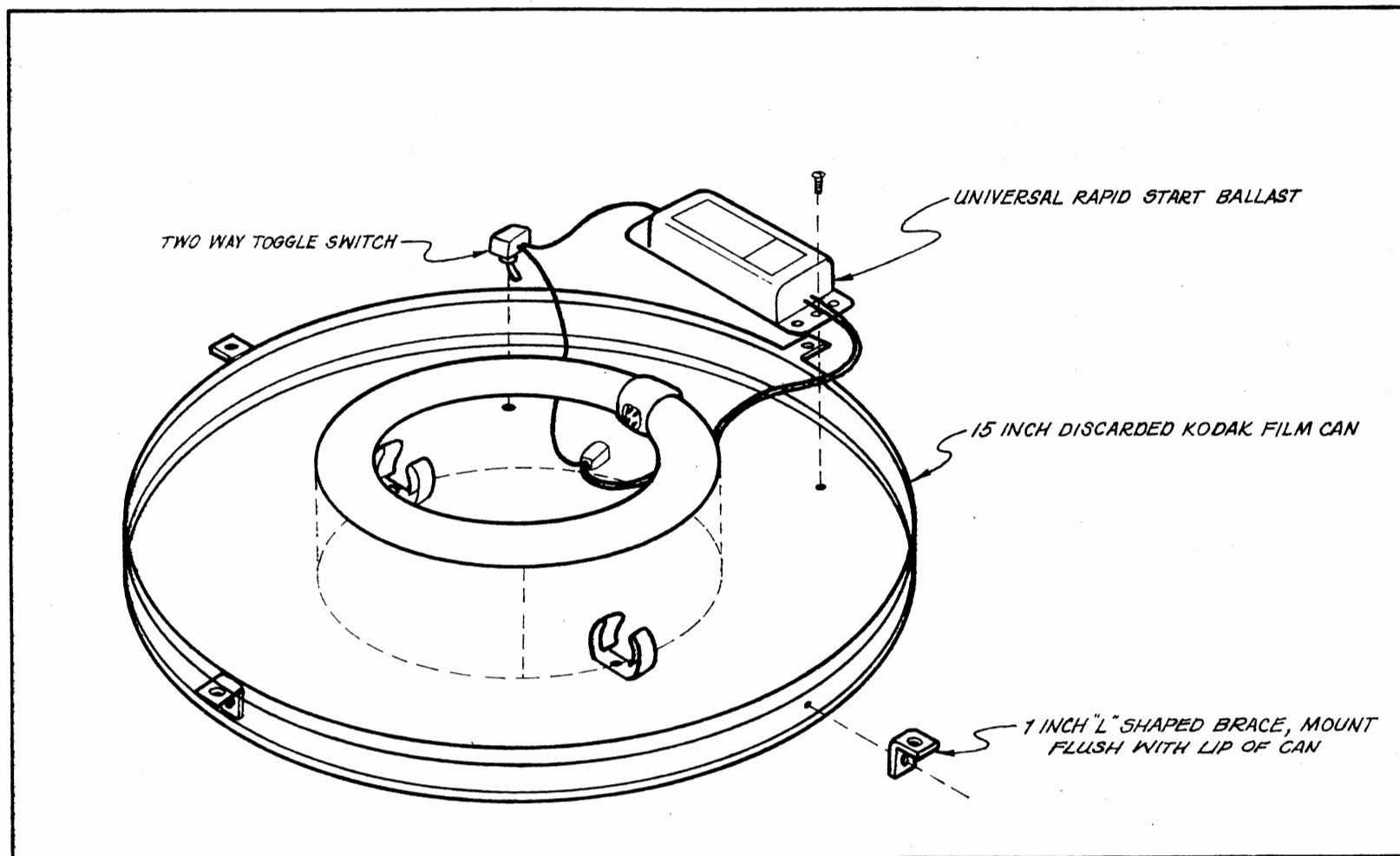

Figure 8. Backlight Unit, Fabrication Plans

Several types of animation discs are commercially available, though they all incorporate basically the same design (Figure 9). Fabrication of a disc through the use of less expensive materials such as plywood and plexiglas can show a substantial savings while retaining the quality needed by the professional (Figure 10).

The Animation Board

In its simplest form, the animation board (Figure 11) is a drawing board adapted for animation by the addition of a pegbar for precise registration and a center backlighted area, cut out and covered with glass or frosted plexiglas to illuminate several layers of drawings at one time.

Many refinements exist to further enhance its usefulness and increase productivity. Incorporation of the back light, pegbar, and a drawing board into one unit with a tilt or slope from back to front (Figure 12) yields portability and added convenience.

The further addition of an animation disc (Figure 13) is useful in augmenting productivity. Madsen (1969) relates:

The value of the rotating disc becomes evident when inking a cel. The relationship of the hand holding the pen (or brush) to the angle of the stroke being made on the cel varies constantly. . . . Either the film maker must accommodate himself to the angle of the line being traced, or the drawing and cel must be turned. . . . An investment in a disc yields dividends in ease of execution, better quality workmanship, fewer ruined cels, and more rapidly completed work (p. 126).

To film the finished cels of an animated sequence, two major pieces of equipment are required. A camera capable of single frame filming and a stand or rostrum on which the camera can be mounted and the cels displayed and registered.

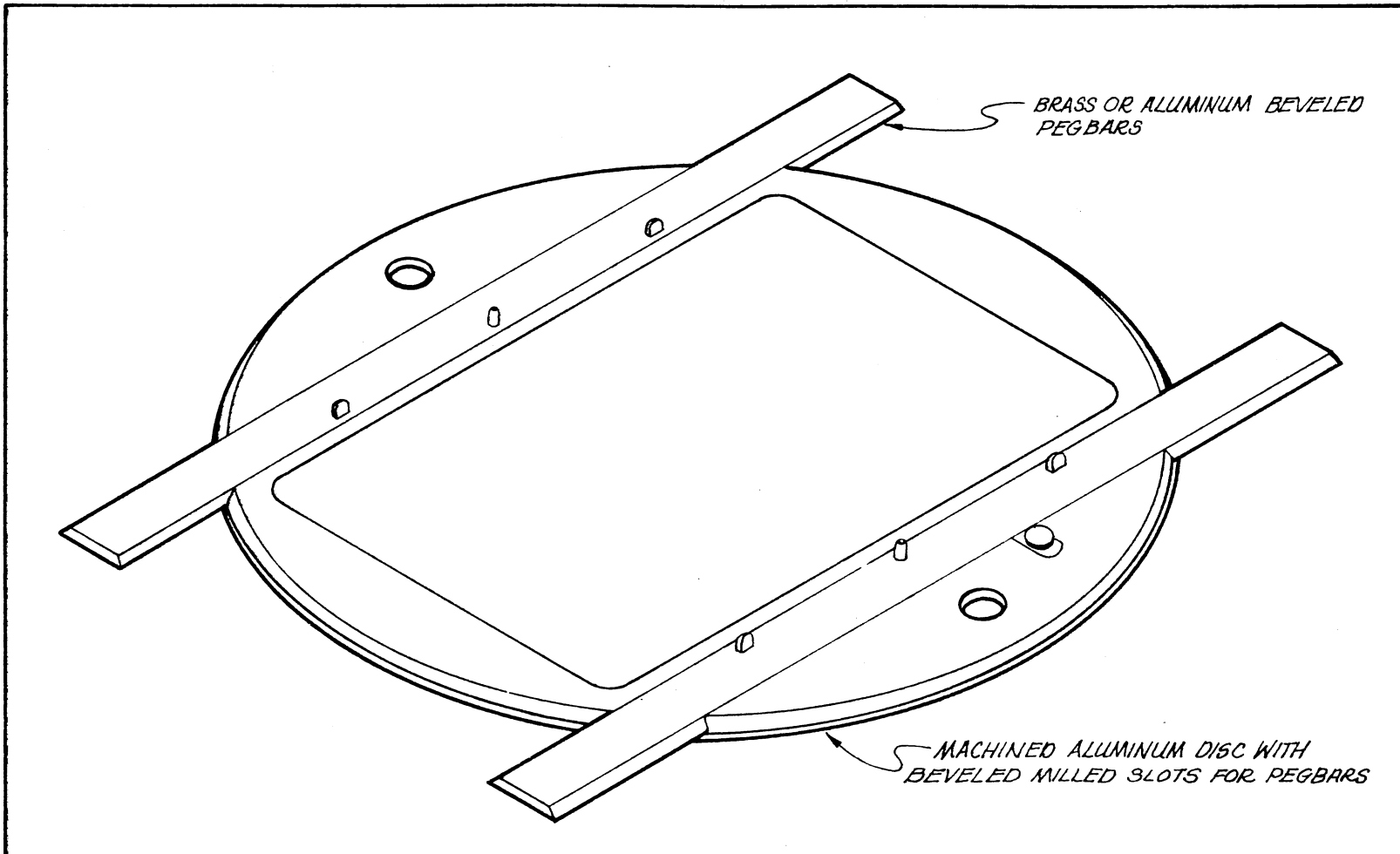

Figure 9. Animation Disc, Commercially Manufactured

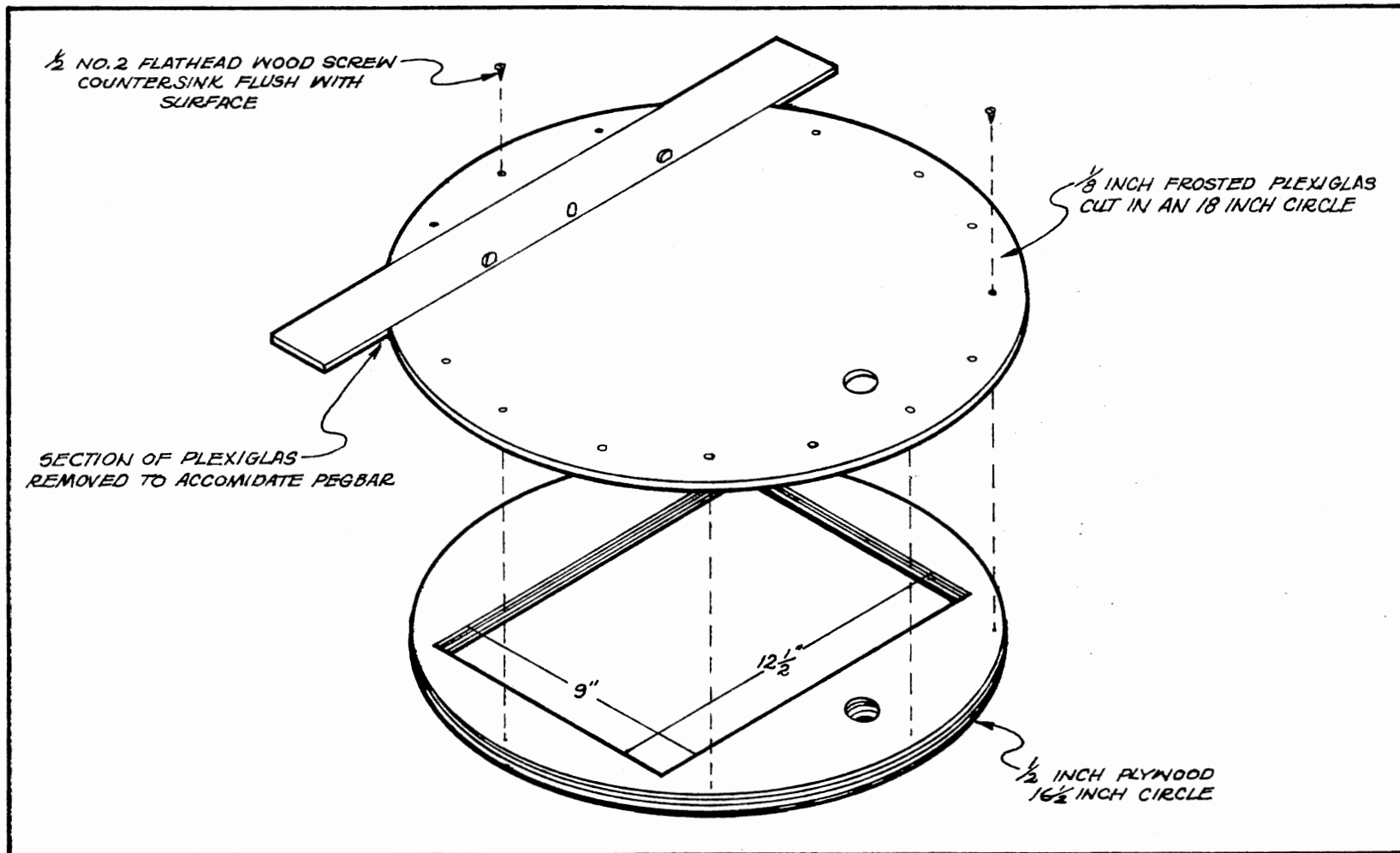

Figure 10. Animation Disc, Fabrication Plans

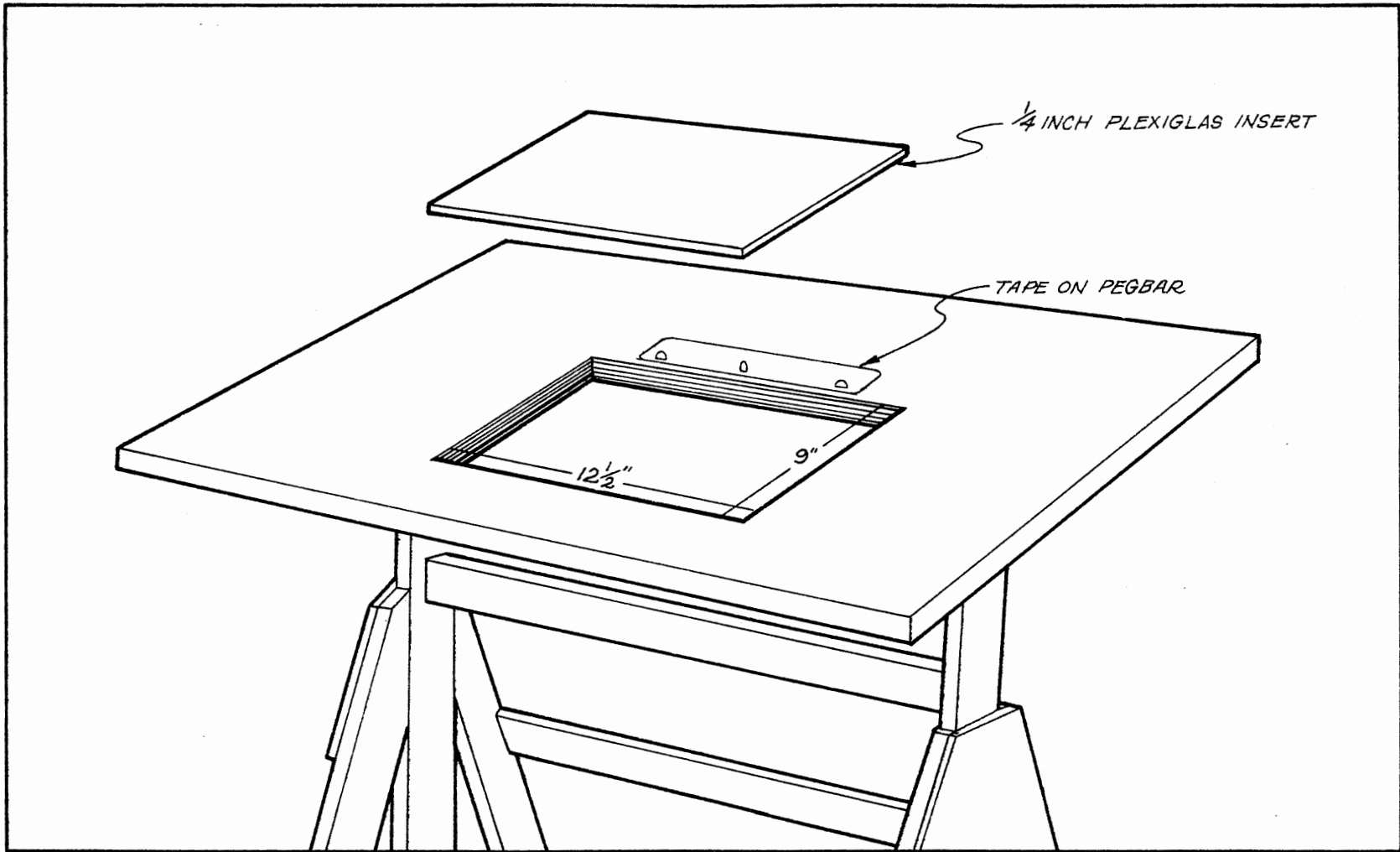

Figure 11. Animation Board with Pegbars

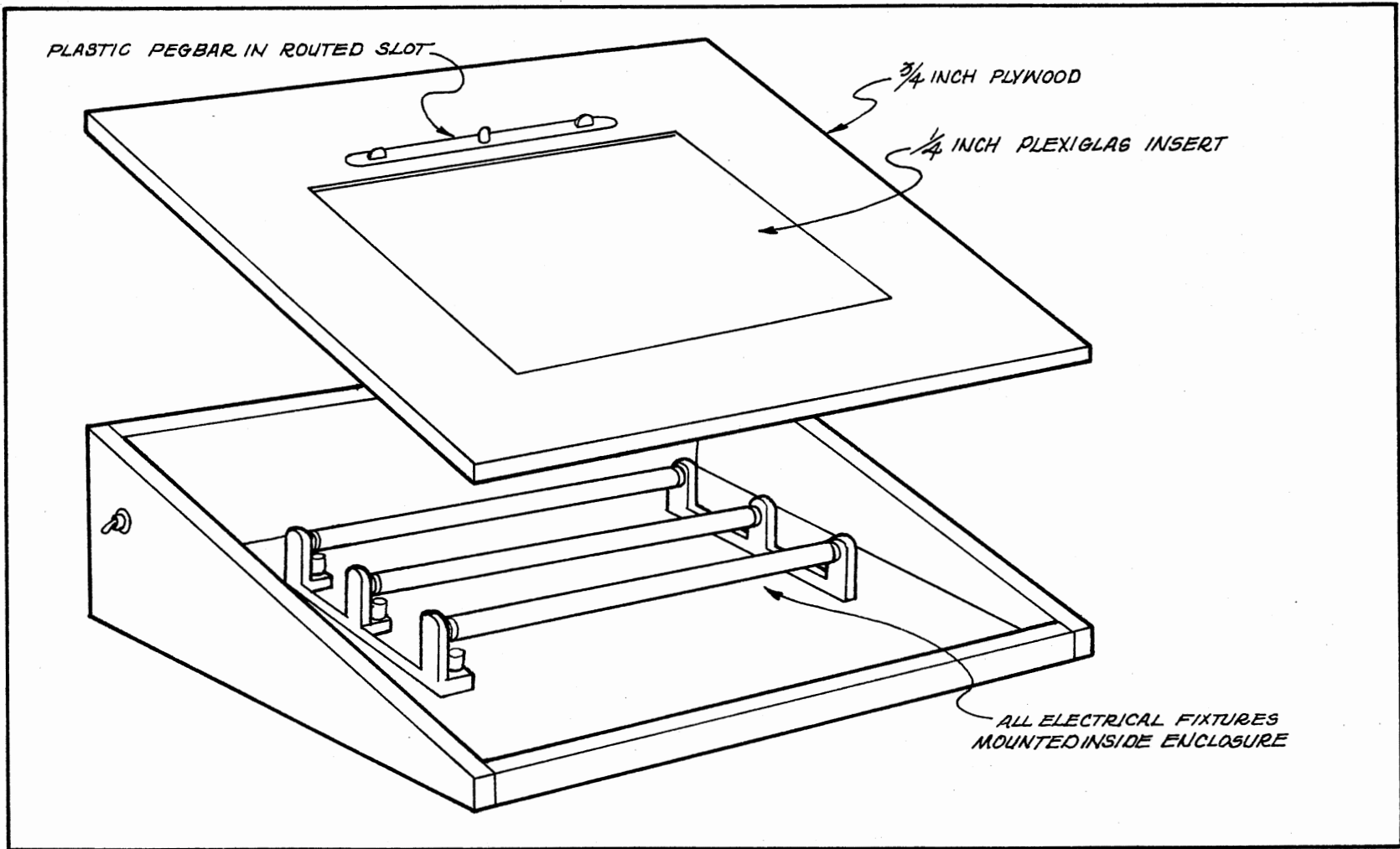

Figure 12. Animation Board, Fabrication Plans

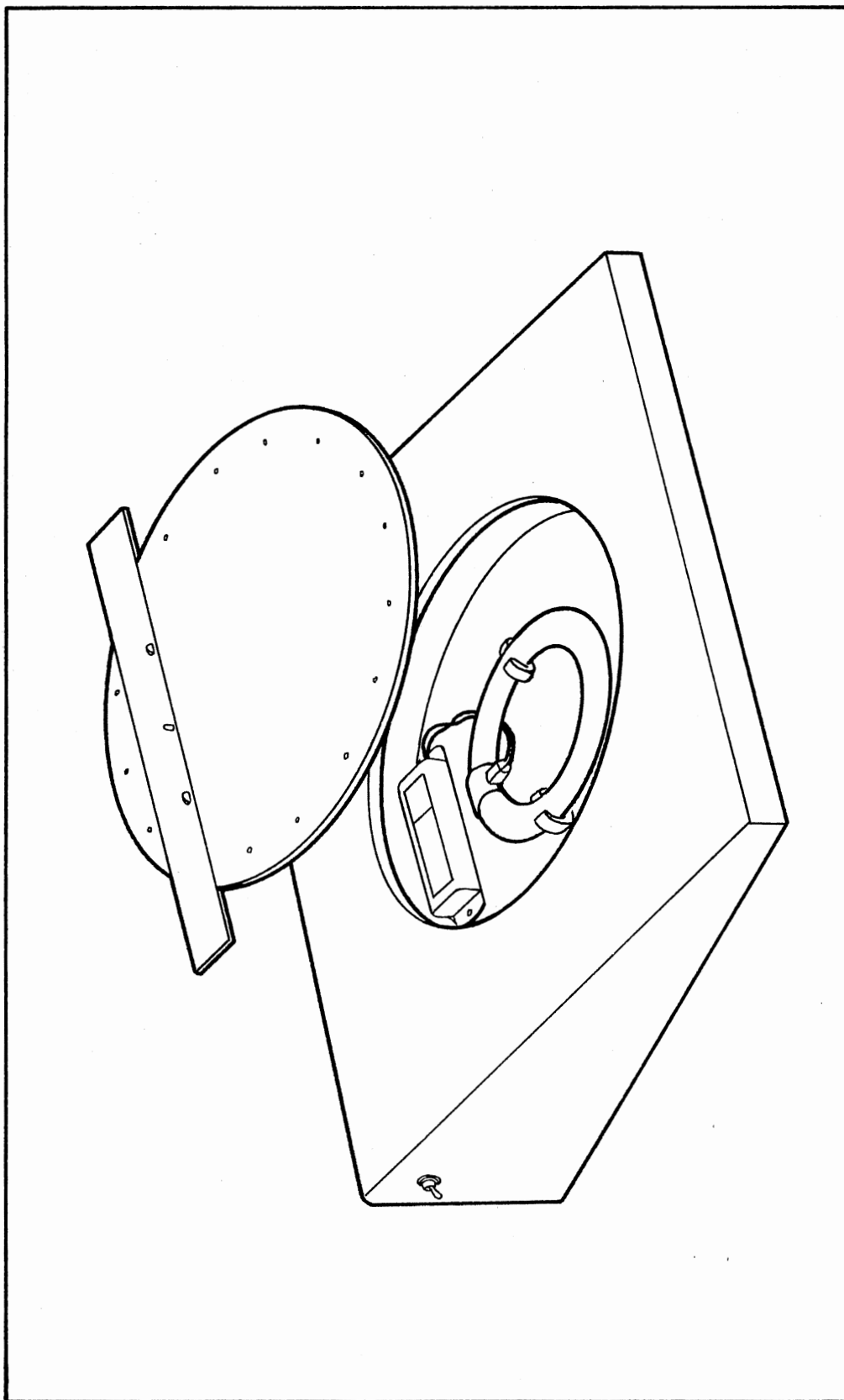

Figure 13. Animation Board with Animation Disc

The Animation Camera

The degree of sophistication needed in the camera is usually determined by budgetary restrictions and the complexity of the animations to be filmed. As is so often the case, added quality and convenience directly contribute to higher costs.

In many cases, the live action camera can be converted or adapted for animation by the addition of a single frame stop motion motor. This method of conversion is very adequate for specific types of animation not requiring special effects.

For optimum quality a camera designed and constructed specifically for animation and stop motion photography is required (Figure 14). Because of the many features built into a camera of this type, the initial purchase price is often easily justified. Madsen (1969) concludes that:

An animation camera should have these capabilities:
(1) single-frame and continuous-exposure control;
(2) forward and reverse movement of film; (3) an intermittent movement (shuttle) and registration system which moves and holds each frame of film precisely the same position for each exposure; (4) a variable opening shutter with calibrated scales;
(5) a reflex or rackover viewfinder which permits viewing of the artwork through the camera lens without exposing the film; and (6) a camera lens suitable for the film format used, with manual or automatic focusing control (p. 40).

The Animation Stand

In its simplest form, the animation stand or camera rostrum can be thought of as having two parts. The top support is for mounting and stabilizing the camera. The bottom support, usually a table

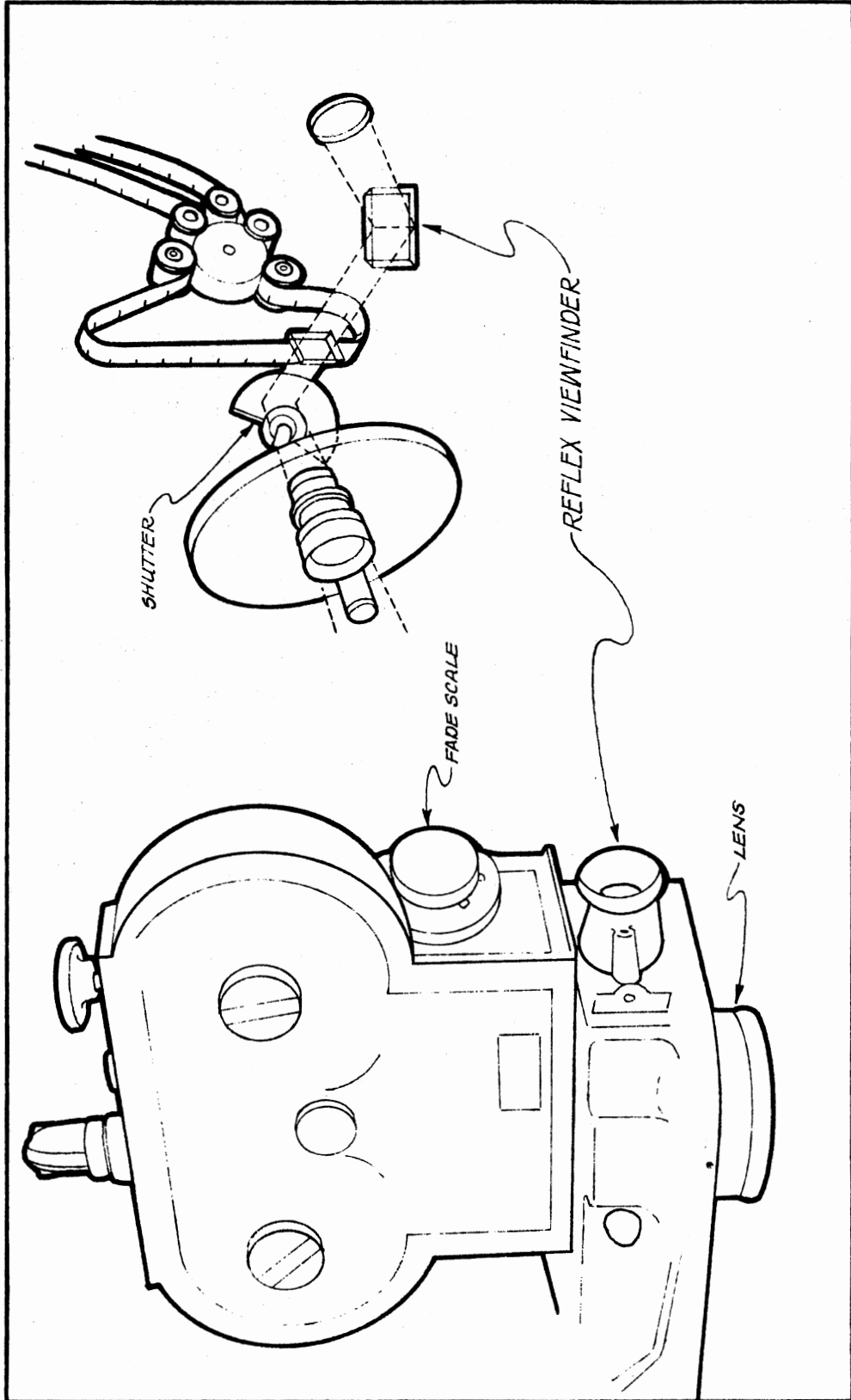

Figure 14. Diagram of an Animation Camera

with a smooth, even surface, is for display of the art. The table rostrum (Figure 15) and the angle aluminum rostrum (Figure 16) serve as examples of this simplified design, employing a static camera technique for simple animations.

Modifications of this basic concept can be made to gain camera mobility. By adding a column or tracking device (Figure 17) the camera can be raised or lowered vertically to any position on the column while being held stable on its horizontal plane.

Horizontal movements; that is, North-South, East-West movements of the animation art can be accomplished with the addition of an animation compound table (Figure 18). An exploded view (Figure 19) shows the simplified design features necessary to fabricate this equipment.

Depending on the specific needs and budget of the designer, a complete and fully professional model (Figures 20, 21) can be constructed for a fraction of the cost of commercially manufactured equipment.

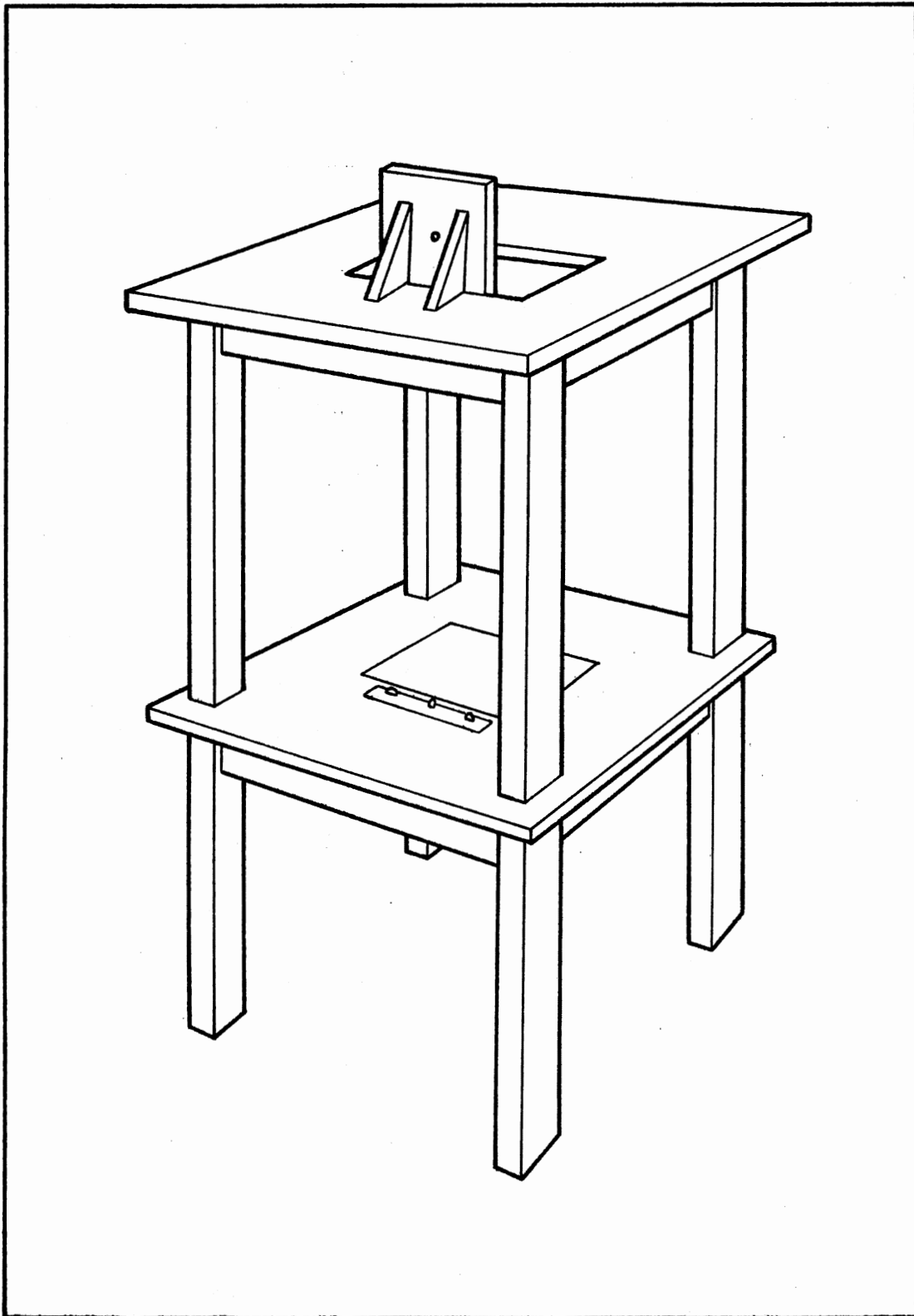

Figure 15. Table Animation Rostrum

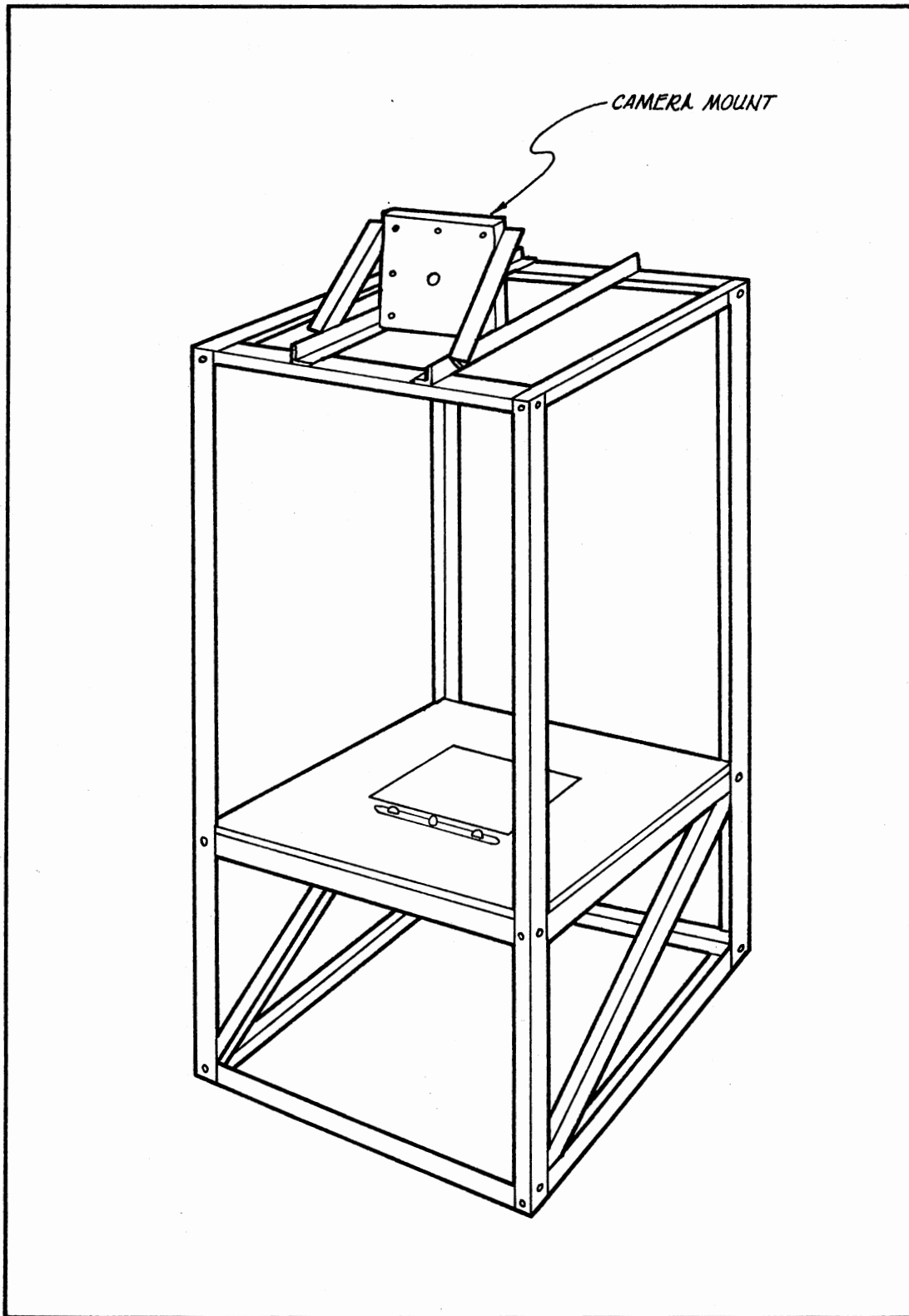

Figure 16. Angle Aluminum Animation Rostrum

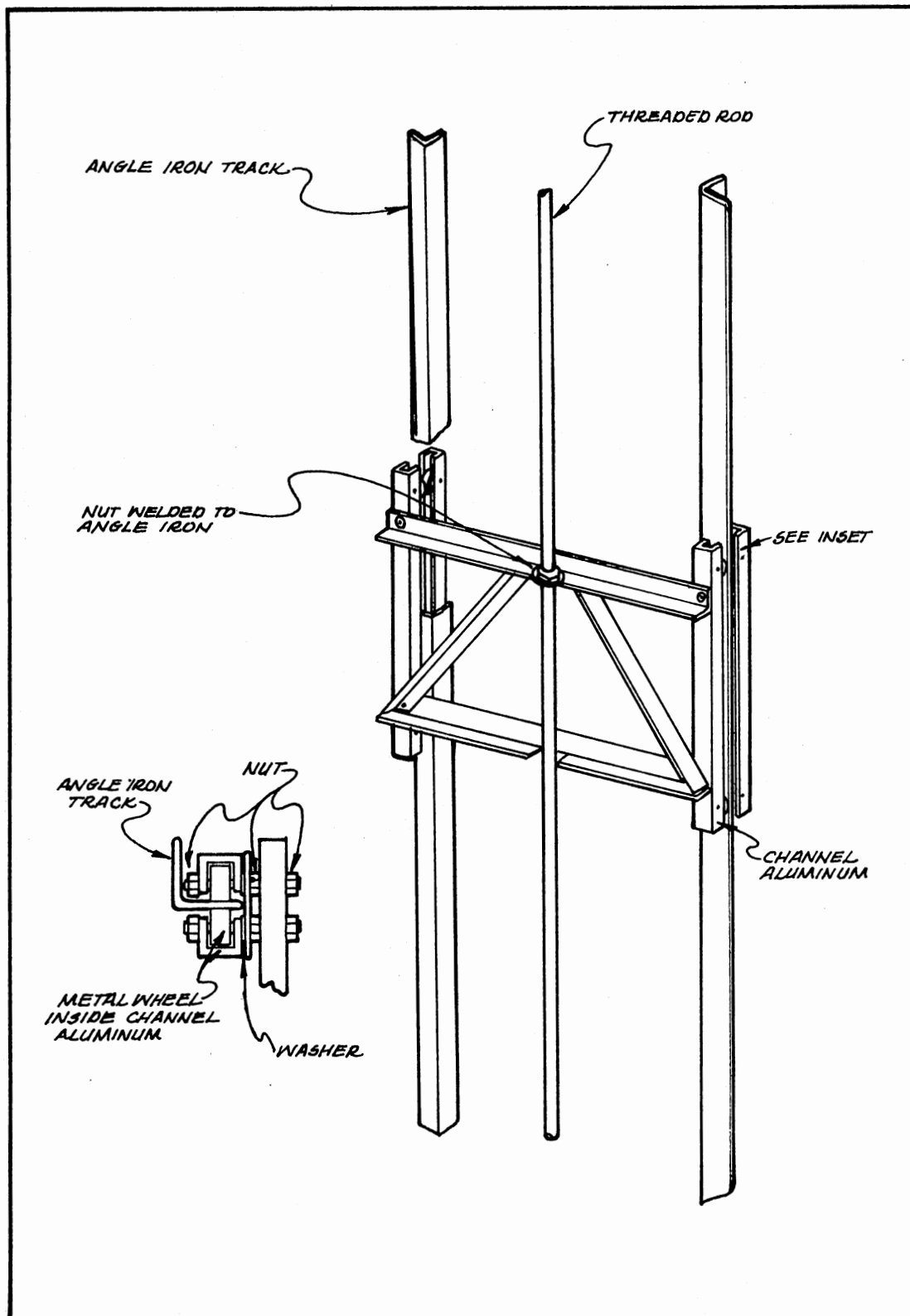

Figure 17. Tracking Columns for Animation Stand, Fabrication Plans

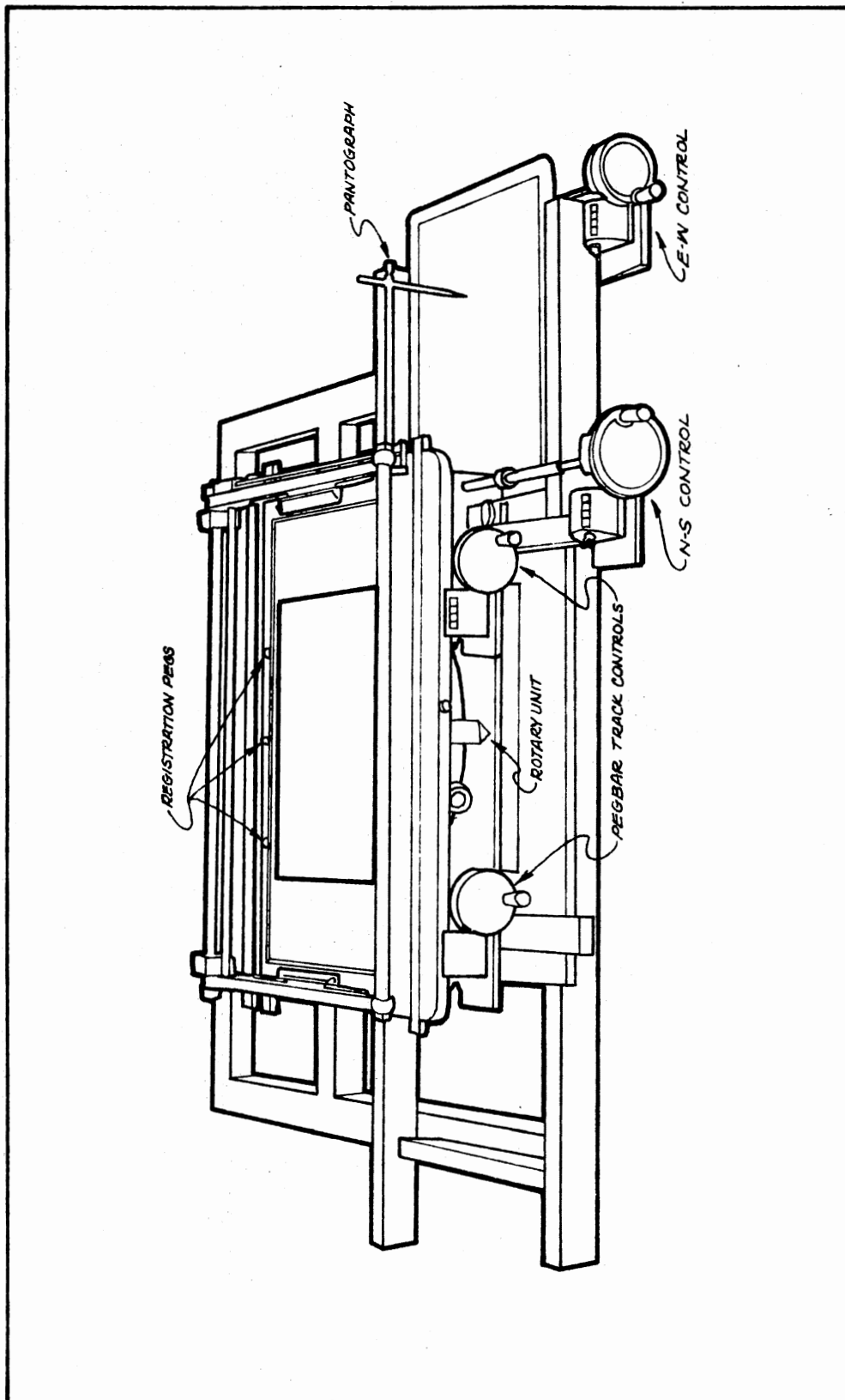

Figure 18. Compound Animation Table

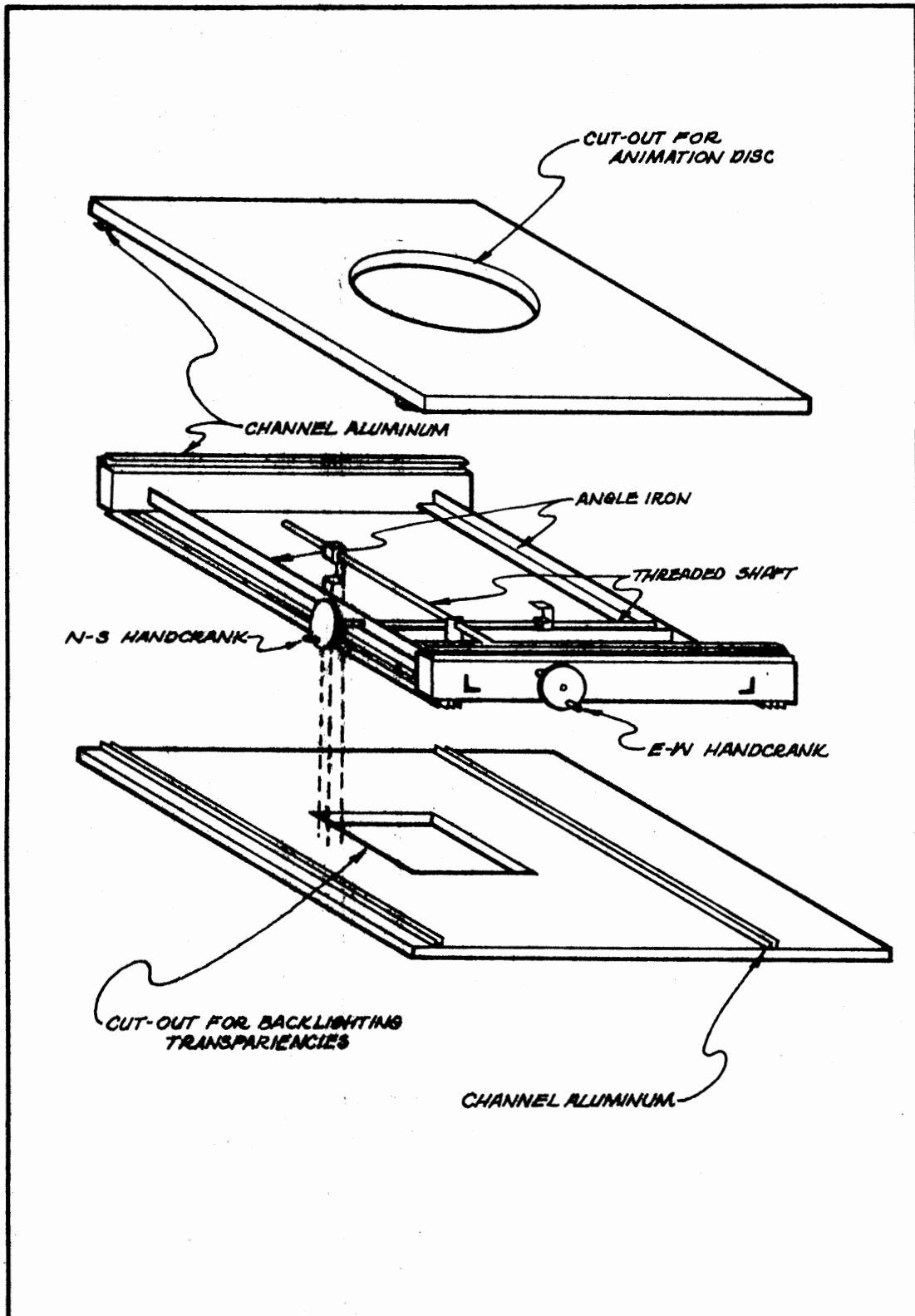

Figure 19. Compound Animation Table, Fabrication Plans

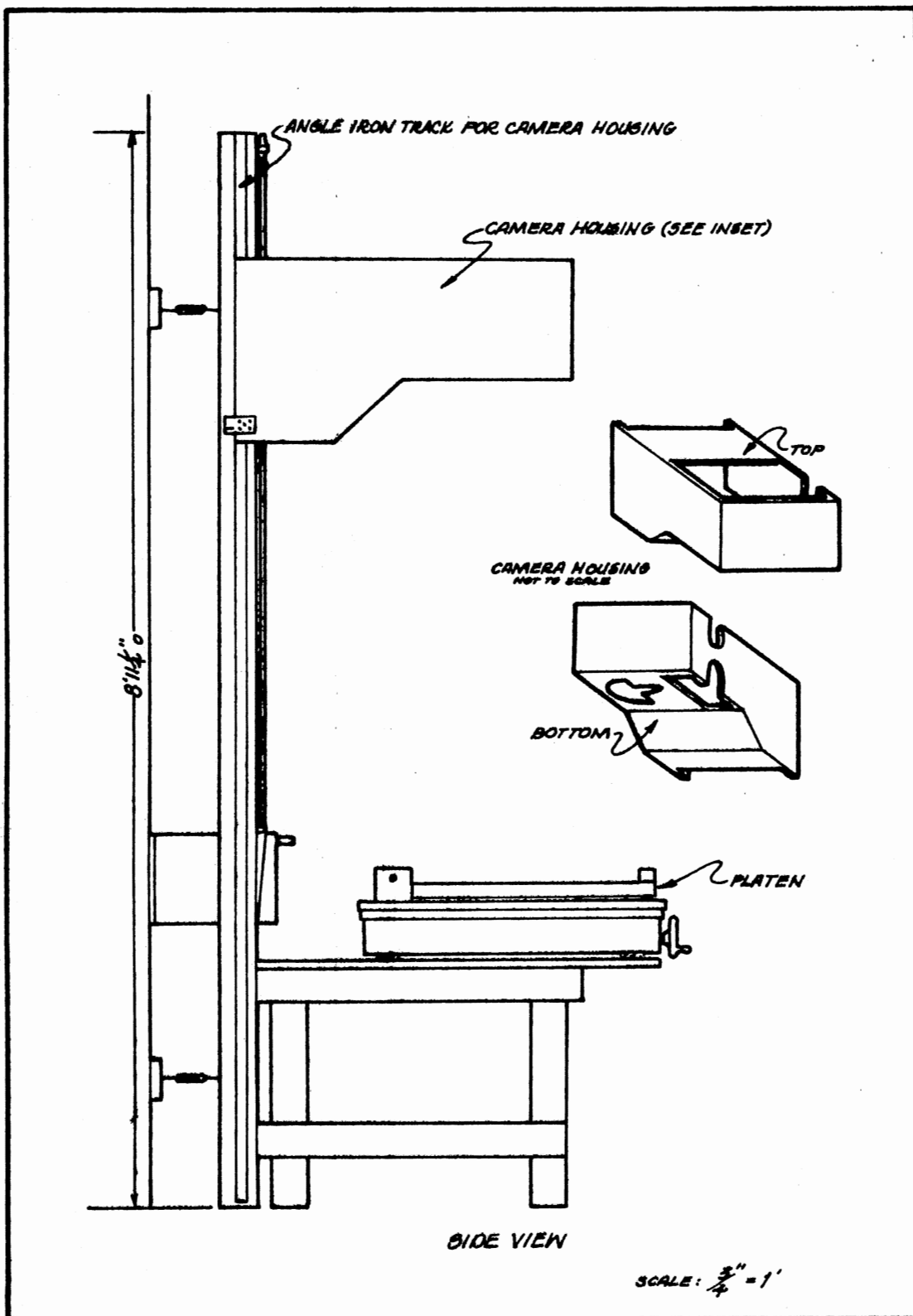

Figure 20. Complete Animation Stand, Fabrication Plans

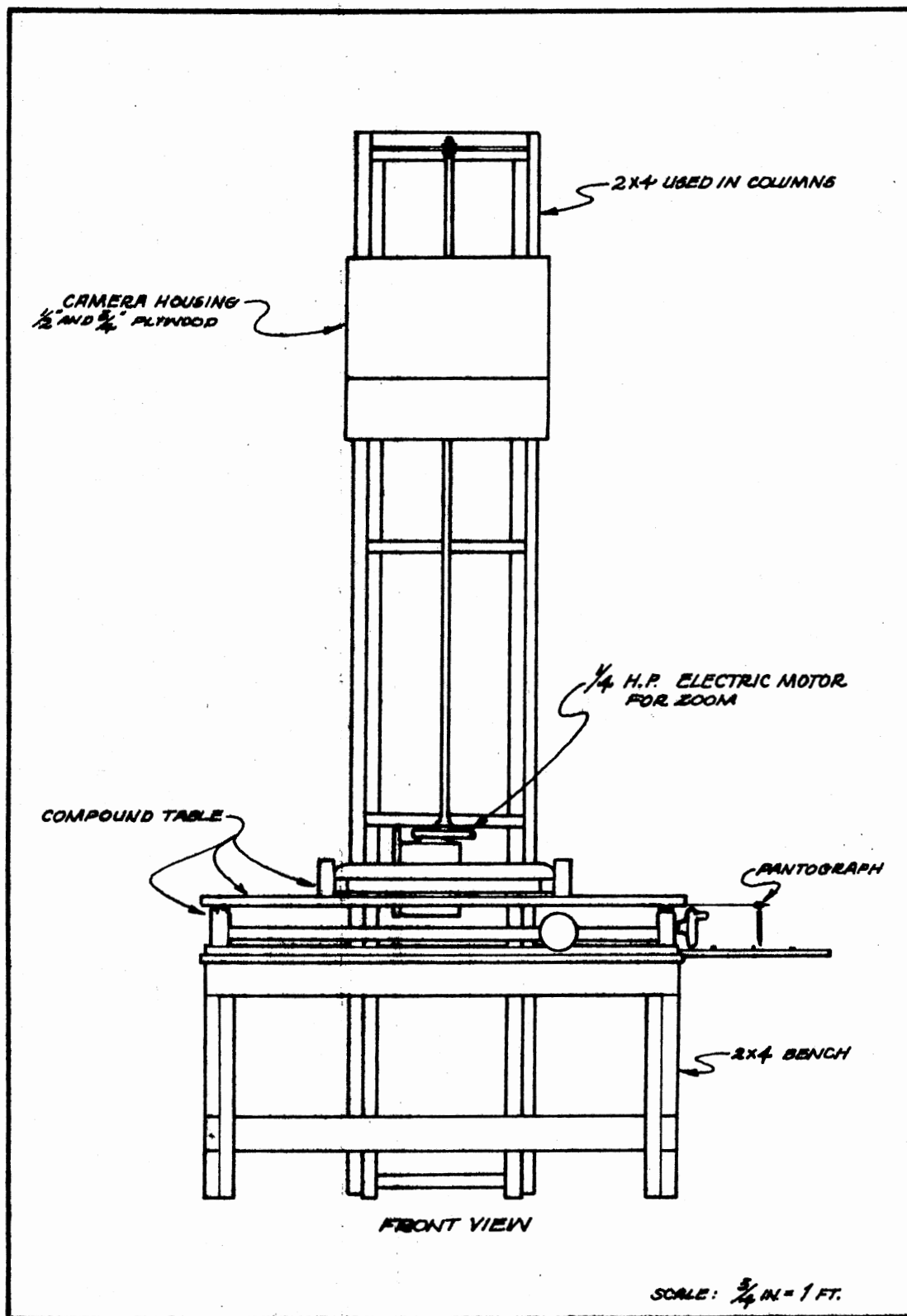

Figure 21. Complete Animation Stand, Fabrication Plans

CHAPTER IV

SUMMARY AND CONCLUSION

Summary

This study was undertaken to define the cel animation process. In addition it presents guidelines and alternatives which will enable the small production unit designer to venture into the field of cel animation.

This was accomplished by explaining the physiological and psychological aspects as well as the physical and technical nature of film animation to determine "what makes it work."

Procedural guidelines were then presented for both the planning and production processes. This was done to establish a background for the presentation of animation equipment alternatives and sources.

Conclusion

It is the author's contention, after much investigation, that cel animation does warrant a place in the small production unit. The designer, being aware of time and cost limitations, can carefully plan the style and length of an animated segment to fit this need. Quality can be maintained at a professional level, although quantity must be curtailed.

The entire production process depends ultimately on the initiative and inventiveness of the designer. Since every designer must establish his own methods and procedures, the final design and fabrication of equipment necessary can be determined only by the individual who will be using it.

Recommendations

Although most of the equipment in the cel animation process can be fabricated, it is the recommendation of the author that two specific items be purchased. The animation pegbars for precise registration during both the production and photographic processes should be purchased, saving both time and money. And since the camera cannot be fabricated, it is recommended that a thorough evaluation of both present and future needs be made to determine the exact camera to best serve for animation, because of the sizeable investment.

SELECTED BIBLIOGRAPHY

- Arnheim, R. "What do the Eyes Contribute?" Audio-Visual Communication Review, Vol. 10 (May, 1962), p. 19.
- Basic Titling and Animation for Motion Pictures. Kodak Publication No. S-21. Rochester, N.Y.: Eastman Kodak Company, 1970.
- Godfrey, B., and Jackson, A. The Do-it-Yourself Film Animation Book. London: British Broadcasting Corporation, 1974.
- Halas, J., and Manvell, R. Art in Movement. New York: Hastings House, 1970.
- Halas, J., and Manvell, R. The Technique of Film Animation. New York: Hastings House, 1963.
- Heath, B. P. Animation in Twelve Hard Lessons. New York: Heath Productions, Inc., 1971.
- Hjelmervik, C. M. "How to Build Your Own Movie Printer." Peterson's Photographic, Vol. 3 (June, 1974), pp. 76-81.
- Hurvell, R. Television Graphics. New York: Van Nostrand Reinhold Company, 1973.
- Kinsey, A. How to Make Animated Movies. New York: Viking Press, 1970.
- Levitan, E. L. Animation Art in the Commercial Film. New York: Reinhold Publishing, 1960.
- Madsen, R. Animated Film Concepts, Methods, Uses. New York: Interland Publishing, 1969.
- Perisic, Z. The Animation Stand. New York: Hastings House, 1976.
- Pittaro, E. "Animation A to Z." Today's Film Maker, Vol. 4 (April, 1975), p. 25.
- Whittaker, R. "Breaking into Animation." Video Systems, Vol. 3 (May, 1977), p. 21.

APPENDIX

ANIMATION: EQUIPMENT AND SUPPLIES

Equipment

Alan Gordon Enterprises, Inc., 1430 N. Cahuenga Blvd., Hollywood,
Cal., 90028.

Behrend's, Inc., 161 E. Grand Ave., Chicago, Ill., 60611.

F & B/Ceco/SOS, 7051 Santa Monica Blvd., Hollywood, Cal., 90038.

Fax Co., 374 S. Fair Oaks Ave., Pasadena, Cal., 91105.

Forox Corp., 511 Center Ave., Mamaroneck, N.Y., 10543.

Lafayette Instrument Co., P. O. Box 1279, Lafayette, Ind., 47902.

National Cine Equipment, Inc., 4140 Austin Blvd., Island Park,
N.Y., 11558.

Oxberry Division of Richmark Camera, 516 Timpson Pl., Brons,
N.Y., 10455.

Sickles, Inc., P. O. Box 3396, Scottsdale, Ariz., 85257.

Supplies

Cartoon Colour Co., Inc., 9024 Lindblade St., Culver City, Cal.,
90230.

F & B/Ceco/SOS, 7051 Santa Monica Blvd., Hollywood, Cal., 90038.

Plastics Suppliers, P. O. Box 24687, Dallas, Tex.

Transilwrap, Inc., 1118 Quaker, Dallas, Tex., 75207.

VITA

John Roger Bolton

Candidate for the Degree of

Master of Science

Thesis: CEL ANIMATION: SMALL PRODUCTION UNIT CONCEPT

Major Field: Housing, Design, and Consumer Resources

Biographical:

Personal Data: Born in Tulsa, Oklahoma, October 27, 1942, the son of Mr. and Mrs. John R. Bolton. Married Kathleen Chapman, November 21, 1964.

Education: Graduated from Bishop Kelley High School, Tulsa, Oklahoma, in May, 1957; received Bachelor of Fine Arts degree from the University of Tulsa, Tulsa, Oklahoma, May, 1971; completed requirements for Master of Science degree, Oklahoma State University in July, 1977.

Professional Experience: Staff Artist, Petroleum Publishing Company, Tulsa, Oklahoma (1967-1968); Art Director, Advertising Associates, Muskogee, Oklahoma (1968-1970); Art Director, Oklahoma State University, Educational Television Services (1970-Present).

Organizations: National Association of Educational Broadcasters, Design Area; Art Directors Club of America.