

A PERFORMANCE EVALUATION OF EXISTING  
OKLAHOMA HIGHWAYS

By

DONALD RAY SNETHEN

Bachelor of Science

Oklahoma State University

Stillwater, Oklahoma

1969

Submitted to the Faculty of the Graduate College  
of the Oklahoma State University  
in partial fulfillment of the requirements  
for the Degree of  
MASTER OF SCIENCE  
May, 1970

OKLAHOMA  
STATE UNIVERSITY  
LIBRARY  
OCT 15 1970

A PERFORMANCE EVALUATION OF EXISTING  
OKLAHOMA HIGHWAYS

Thesis Approved:

*L. Allen Haliburton*  
\_\_\_\_\_  
Thesis Adviser

*Phillip S. Manke*  
\_\_\_\_\_

*James H. Pacher*  
\_\_\_\_\_

*D. Durban*  
\_\_\_\_\_  
Dean of the Graduate College

762805

## ACKNOWLEDGMENT

The author wishes to express gratitude and sincere appreciation to the following individuals:

To his major adviser, Professor T. Allan Haliburton, for his consultation and expressed interest throughout this research.

To his committee members, Professor J. V. Parcher and Professor P. G. Manke for their interest and encouragement throughout this study.

To his wife, Cheryl, for her devotion, encouragement, and understanding throughout this study.

To his parents, Milton and Mary Ann Snethen, for their support and encouragement throughout this study.

To his parents-in-law, Harvey and Lucille Edsall, for their interest and encouragement during the writing of this thesis.

To Mr. Eldon Hardy for assistance in preparation of graphical portions of this thesis.

To Mrs. Linda Schroeder for typing this manuscript.

## TABLE OF CONTENTS

Chapter	Page
I. INTRODUCTION . . . . .	1
Statement of the Problem. . . . .	2
Scope of the Investigation . . . . .	2
II. SUMMARY OF RESEARCH CONCERNING PAVEMENT PERFORMANCE ON EXPANSIVE SOILS. . . . .	3
Effects of Subgrade Moisture Change on Pavement Performance . . . . .	3
Current Methods for Minimizing Subgrade Moisture Effects . . . . .	5
Avoiding or Altering Encountered Expansive Soil . .	6
Increased Subgrade Confinement . . . . .	7
Minimizing Subgrade Moisture Variations . . . . .	8
Current U.S. Highway Design Practices . . . . .	11
III. EFFECT OF PAVEMENT COMPONENTS ON SUBGRADE MOISTURE CONDITIONS . . . . .	21
Base Course . . . . .	23
Subbase . . . . .	31
Improved Shoulders. . . . .	37
Drainage Conditions . . . . .	42
Summary . . . . .	44
IV. EVALUATION OF PAVEMENT PERFORMANCE . . . . .	47
Summary . . . . .	49
V. CONCLUSIONS AND RECOMMENDATIONS. . . . .	50
REFERENCES . . . . .	53
APPENDIX - CODING CRITERIA FOR SORTING ROUTINE . . . . .	54

## LIST OF FIGURES

Figure	Page
2.1. Various Applications of Asphaltic Membranes for Protection of Expansive Clay Subgrades . . . . .	10
2.2. A Current Pavement Design in Missouri . . . . .	13
2.3. A Current Pavement Design in Kansas . . . . .	13
2.4. A Current Pavement Design in Minnesota . . . . .	14
2.5. Three Typical Pavement Designs in Iowa. . . . .	14
2.6. Current Fill and Pavement Designs in South Dakota . . . . .	15
2.7. Experimental Pavement Designs in South Dakota . . . . .	16
2.8. Experimental Pavement Designs in South Dakota . . . . .	17
2.9. Experimental Pavement Designs in Colorado . . . . .	18
2.10. Experimental Pavement Designs in Utah . . . . .	19
2.11. A Current Pavement Design in Arizona . . . . .	20
2.12. A Current Pavement Design in California . . . . .	20
3.1. Moisture Variations at Selected Levels Beneath Pavement Centerline at Site No. 44 . . . . .	25
3.2. Differential Movement of Shoulder at Site No. 44. . . . .	27
3.3. Moisture Variations at Selected Levels Beneath Pavement Centerline and Edge at Site No. 41 . . . . .	29
3.4. Moisture Variations at Selected Levels Beneath Pavement Centerline at Site No. 21 . . . . .	30
3.5. Moisture Variations at Depth of 2.5 Feet Beneath Pavement Centerline for Sites No. 39 and 40 . . . . .	34
3.6. Moisture Variations at Selected Levels Beneath Pavement Centerline at Site No. 20. . . . .	36

Figure	Page
3.7. Range of Moisture Variations at Depth of 2.5 Feet at Site No. 4 . . . . .	39
3.8. Range of Moisture Variations at Depth of 2.5 Feet at Site No. 33 . . . . .	40
3.9. Range of Moisture Variations at Depth of 2.5 Feet at Sites No. 37 and 38. . . . .	43
3.10. Subgrade Moisture Distribution at Depth of 2.5 Feet at Site No. 12 . . . . .	45

## CHAPTER I

### INTRODUCTION

Performance of Oklahoma highways is related to existing subgrade moisture conditions. Subgrade moisture variations, with associated volume change and strength loss characteristics, may cause more damage to existing pavements on expansive soil than any other factor involved. Damage begins with deterioration of the pavement in the form of unevenness, transverse and longitudinal cracking, and formation of "potholes", which in turn lead to uncomfortable travel, high maintenance costs, and even, in extreme cases, complete pavement failure. An evaluation of pavement performance under known moisture, climatic, and soil conditions could be extremely valuable in formulating better pavement designs for Oklahoma highways.

The School of Civil Engineering at Oklahoma State University is presently engaged in a six-year Subgrade Moisture Variations research project, which began in June, 1964. The project is sponsored by the Oklahoma Department of Highways and the U. S. Department of Transportation, Federal Highway Administration, Bureau of Public Roads.

Subgrade moisture and density data have been collected at 50 field research sites in north central and northeastern Oklahoma. Data was collected for a three year period from sites 1 - 30 and for two years from sites 31 - 50. Other information compiled from the field research sites includes soil profiles, climatological data, typical cross section

details, surface condition ratings, average daily traffic, field observations, and photographic records.

#### Statement of the Problem

Recent project research (Refs 1, 2, 3) has greatly increased the understanding of factors causing subgrade moisture variations beneath existing Oklahoma highways. A performance evaluation of present pavement designs with emphasis on subgrade moisture variations and related factors will aid in developing recommendations for future highway design criteria.

#### Scope of the Investigation

The scope of this investigation of fourfold: 1) to review previous work concerning subgrade moisture variations in conjunction with pavement performance and design, 2) to establish an understanding of the effect of pavement components on subgrade moisture conditions, 3) to evaluate the performance of Oklahoma highways with respect to subgrade moisture conditions, and 4) to discuss recommendations for revision of pavement design criteria in Oklahoma.



## CHAPTER II

### SUMMARY OF RESEARCH CONCERNING PAVEMENT PERFORMANCE ON EXPANSIVE SOILS

The performance of highways on expansive clay soils has come under serious consideration during the past decade. The need for more and better highways with minimum maintenance costs has become the basis for extensive research into the variables influencing expansive clay behavior. Through this research, quantitative evaluation of pavement performance with emphasis on subgrade behavior will lead to better pavement designs for the future.

#### Effects of Subgrade Moisture Change on Pavement Performance

Pavement performance, good or bad, is affected by volume change characteristics of expansive clay subgrades. In Oklahoma, as well as many other Great Plains states, the major factor contributing to volume change is subgrade moisture variation, from moisture movement in the soil.

Moisture may flow in the liquid phase, vapor phase, or a combination of the two, depending on the force or forces acting on the soil-water system. Marks and Haliburton (Ref 1) outline and describe capillary pressure, osmotic pressure, hydrostatic pressure, and chemical potential as forces which cause moisture movement in soils. Osterhout and Haliburton (Ref 2) investigated temperature gradients as an additional

force which can cause movement.

For moisture movement to occur, there must be a source of free water. Marks and Haliburton (Ref 1) list six sources of moisture in subgrades: 1) seepage of water into the subgrade from higher ground, 2) fluctuation of the water table, 3) percolation of water through the pavement surface, 4) migration of water from shoulders, slopes, or verges, 5) migration of water from water bearing layers below the subgrade, and 6) transfer of water vapor from any of the above sources.

Kassif, Livneh, and Wiseman (Ref 4) state that phenomena which result from changes in the moisture content of clay subgrades may vary and depend on the type and shape of the pavement, but the following behavior may be noted:

1. shrinkage due to drying,
2. swelling due to wetting,
3. development of swelling pressures when confined from swelling,  
and
4. decreased strength and bearing capacity as a result of  
swelling.

In general, several phenomena occur at the same time and cause deterioration of the pavement, which in turn leads to poor riding quality, high maintenance costs, and even, in extreme cases, to failure of the pavement.

Kassif, Livneh, and Wiseman (Ref 4) note that damage to pavements on expansive clays appears to be in four major forms:

1. The appearance of unevenness along a significant length of the road surface without any cracking or other visible damage. This type of damage is the most common and is the

- major factor affecting highway riding qualities. The unevenness may be continuous, cyclic or completely random.
2. Development of longitudinal cracking, parallel to the road centerline. This type of damage is very common, and causes uneven deformations over the breadth of the road. Longitudinal cracking usually occurs close to the shoulders, although cracking sometimes occurs near the centerline.
  3. Development of significant localized deformations which are generally accompanied by lateral cracking. This type of damage is very common and occurs at any point along the length of the road where structures exist which lead to discontinuities in the subgrade, for example in the region near culverts, or in areas where trees have been planted along the roadside.
  4. Localized failure of the pavement, accompanied by disintegration of the road surface. One common type of localized failure results from insufficient bearing capacity of the subgrade. This may show up as cracking in all directions, rapid crumbling of the upper layer, and/or formation of potholes.

#### Current Methods for Minimizing Subgrade Moisture Effects

A major problem in design of pavements and their continued performance on expansive clays is prevention of subgrade moisture variations, to minimize distortion and cracking after construction. To date no method used has been completely successful in solving this problem, although damage has been markedly reduced in some cases. Methods used to solve the problem may be grouped into three main classes:

1. avoid or alter the expansive soil,
2. increase confinement or surcharge on the clay subgrade, and
3. minimize subgrade moisture variations by subgrade prewetting, preventing subgrade drying, lengthening the overall construction period, waterproofing the subgrade, or using properly designed drainage and shoulders.

#### Avoiding or Altering Encountered Expansive Soil.

One method of avoiding expansive clay may be accomplished by changing the horizontal or vertical alignment of the highway during preliminary planning. However, in many parts of Oklahoma expansive clays are so abundant that the expense incurred would considerably exceed any benefits gained.

A second method would be to undercut the subgrade and replace it with a more stable material. This method is quite feasible if the subgrade is undercut to a depth of the active zone of expansive behavior and a source of stable material is available. Problems arise with disposing of the undercut material if the excavation is large. The cost of the road is also increased as a result of purchasing, hauling, and compacting the stable material.

Altering the expansive clay with chemical additives, for example lime, lime-fly ash, cement, and salt are the methods most widely used. Satisfactory mixing of the chemical and clay to substantial depths is a major problem in present highway construction procedures. In general, it has been found economical to treat only the upper 6-12 inches of the subgrade. The Research and Development Division, Oklahoma Highway Department is currently studying lime treatment of expansive subgrades

to depths of two feet. The purpose of the study is twofold: 1) to determine if two feet of subgrade soil could be plowed, mixed with lime, and recompactd in a single lift, and 2) to determine if the characteristics of the subgrade soil could be altered sufficiently to result in a reduction of surfacing quantities and overall savings in construction cost without loss of structural integrity. Published data on the research reveal favorable results, but the full benefit of lime treatment to a depth of two feet will be determined in years to come.

Though limitations exist, McDowell (Ref 5) outlines several advantages of lime treatment. The lime treated layer: provides a stable working surface for continuation of the paving process, particularly after rains; allows a certain amount of water to penetrate into the subgrade, causing it to lose some of its swelling characteristics, particularly during flooding for curing purposes; acts as a barrier against drying and wetting after the pavement is complete; and increases the bearing capacity of the subgrade and so decreases the required pavement thickness. It may be noted that lime treatment is definitely advantageous, but does not solve all the problems associated with expansive soils. McDowell (Ref 5) has stated that ". . . extensive vertical movements due to swelling or heaving of deep layers of soil are not overcome by lime treatment or any other treatment applied in thin layers . . ." Therefore, lime treatment alone is not necessarily a solution of the problem.

#### Increased Subgrade Confinement

Increasing confinement by the use of fill sections or increased pavement thickness is practical where potential subgrade expansion is

relatively low. If the confining load on an expansive clay is equal to or greater than the expansion pressure developed in the subgrade, no swelling will occur as a result of moisture variations. The California Division of Highways designs their pavement partly on the requirement that the pavement shall weigh enough to prevent expansion of the clay subgrade.

#### Minimizing Subgrade Moisture Variations

Minimization of moisture variations on expansive clay subgrades has a significant effect on pavement performance. This factor should be considered in both the design and construction stages. Five methods presently being used to minimize subgrade moisture variations are subgrade prewetting, preventing subgrade drying, lengthening the overall construction period, waterproofing the subgrade, and use of properly designed drainage and shoulders.

Subgrade prewetting is not really a method for minimizing moisture variations, but rather a means to allow a large portion of potential swell to occur prior to construction. Prewetting allows the establishment of new, stable moisture-density conditions in the subgrade. The effects of prewetting are enhanced by undercutting the subgrade and ponding water in the excavation. It should be noted that, to date, prewetting has been used primarily on an experimental basis.

The practice of preventing drying of exposed subgrade soils is useful in both cut and fill sections during and after construction. Various steps can be taken during construction to prevent drying; they include: insuring minimum delay between excavation, spreading and compaction of the subgrade and construction of the pavement layers,

particularly during the summer; minimizing evaporation by covering the subgrade with layers of granular material; or adding water in an attempt to keep the moisture content near the plastic limit.

Delaying the final paving may also serve to minimize future moisture variations. Delayed paving allows more time for the natural adjustment of moisture-density conditions and can be accomplished by stage construction. In this procedure, a temporary pavement structure is used for a year or more and final paving is postponed until initial volume changes have essentially stopped. The use of asphalt coatings without allowing traffic on the surface is a similar alternative to this procedure.

Waterproofing of expansive clay subgrades can be accomplished by the application of asphaltic membranes. Harris (Ref 6) describes three methods in which asphaltic membranes are used in highway construction in Texas, see Fig 2.1, they include: an asphaltic concrete layer below the final wearing surface; a membrane applied directly on the subgrade; and an envelope membrane primarily used in fills. Complete prevention of moisture movement using asphaltic membranes is impossible in most cases, but the reduction in moisture variations may give a more nearly uniform and tolerable volume change across the pavement section.

Drainage systems for pavements on expansive clay soils are generally limited to open ditches along the edge of the shoulders. In most cases, the pavement shoulders are left exposed to the climate and as a result are subject to seasonal effects. Winter precipitation infiltrates the soil by means of open cracks from the preceding dry season and is not able to drain, therefore moisture migration begins in all directions, including laterally toward the pavement

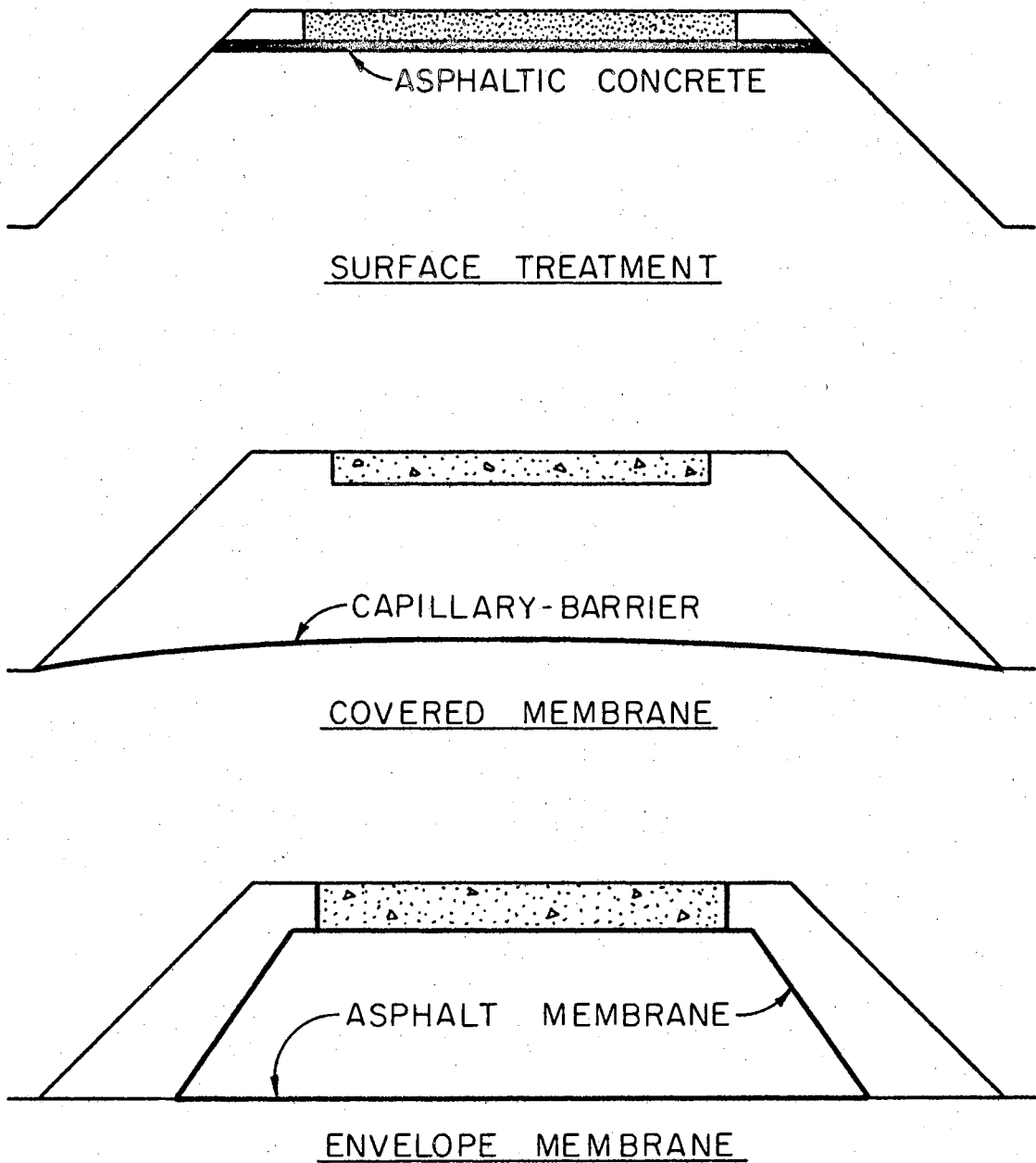

Figure 2.1. Various Applications of Asphaltic Membranes for Protection of Expansive Clay Subgrades



subgrade. Most of the serious damage to pavements on expansive clay subgrades results from these lateral moisture variations and accompanying lateral movements. The proper design of shoulders and drainage (both surface and subsurface) must be aimed at maintaining stable conditions at the pavement edges.

Kassif, Livneh, and Wiseman (Ref 4) recommend the following measures for proper drainage and shoulder performance:

1. The shoulders should be extended to a width at least equal to the depth of the active zone.
2. The shoulders should have the same total thickness as the pavement and be built of select non-swelling material.
3. Surface drainage should be located as far away from the edge of the pavement as is practicable.
4. Cut sections are preferable to fill sections.
5. Membranes, if used above the subgrade, should be carried through the full width of the shoulders and preferably as far as the open ditch surface drains.
6. Subsurface drainage should be located at the outside edge of shoulders and as deep as possible. The trench containing the subsurface drain should be backfilled with fine sand which will act as a cutoff against lateral flow of water and as a desirable source of moisture during the dry season.

#### Current U. S. Highway Design Practices

Better highways are the goal of all highway departments and only through research and experimentation will better highways be built. Sallberg and Smith (Ref 7) present a number of examples of current

(1965) pavement designs and experimental sections in the Great Plains and Western states. All examples are located on expansive clay and in climates which vary from arid to semi-arid. Pertinent data regarding subgrade properties, structural design, position of ground water, rainfall, and pavement performance are given for each typical section, shown in Figs 2.2, 2.3, 2.4, 2.5, 2.6, 2.7, 2.8, 2.9, 2.10, 2.11, and 2.12. It should be noted from the Figures that several of the previously described procedures for minimizing moisture variations and resulting volume changes are used extensively.



SOIL	A-7-6(16) LL=46, PI=28, 40 PERCENT < 0.005 MM. FROM GLACIAL TILL, MONTMORILLONITE CLAY
WATER TABLE	DEEP, HAS LITTLE OR NO EFFECT ON SUBGRADE SOIL
PRECIPITATION	42 INCHES A YEAR
PERFORMANCE	GOOD SINCE CONSTRUCTION IN 1962

Figure 2.2. A Current Pavement Design in Missouri

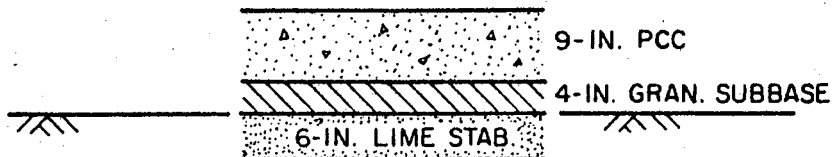

SOIL	A-6, A-7-6, LL=32 TO 60, PI=17 TO 36 CLAY MAINLY MONTMORILLONITE, SOME ILLITE
WATER TABLE	25 FEET
PRECIPITATION	32 INCHES A YEAR
PERFORMANCE	GOOD ON SIMILIAR DESIGNS

Figure 2.3. A Current Pavement Design in Kansas

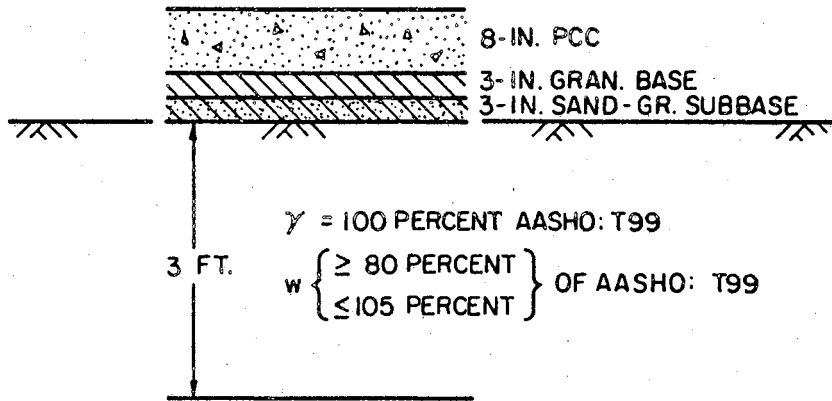

SOIL	A-7, LL = 42 TO 59, PI = 18 TO 34, MINIMUM CLAY CONTENT = 33 TO 53 PERCENT
WATER TABLE	CONSIDERABLE DEPTH
PRECIPITATION	23 INCHES A YEAR
PERFORMANCE	GOOD; BUILT 1950, INSIGNIFICANT WARPING

Figure 2.4. A Current Pavement Design in Minnesota

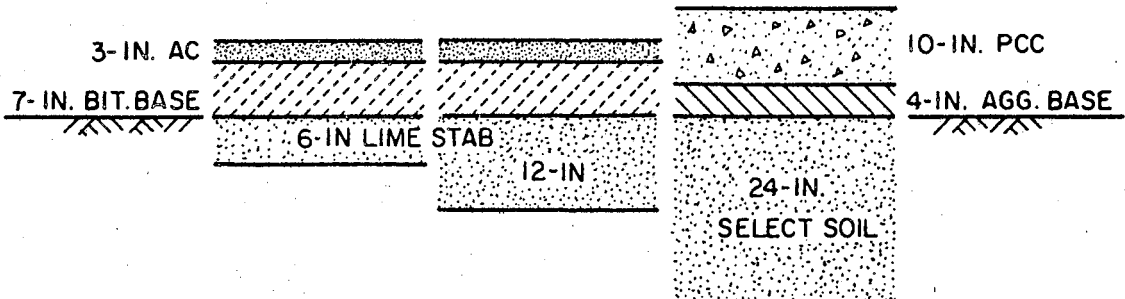

SOIL	A-7-6(20) LL = 84, PI = 55 83 PERCENT < 0.005 MM.	A-7-6(20) LL = 63, PI = 39 MONTMORILLONITE CLAY MINERAL
WATER TABLE	5 FT. BELOW GRADE	UNKNOWN
PRECIPITATION	28 INCHES A YEAR	31 INCHES A YEAR
PERFORMANCE	GOOD FOR PAST 3 YRS.	GOOD FOR PAST 25 YEARS

Figure 2.5. Three Typical Pavement Designs in Iowa

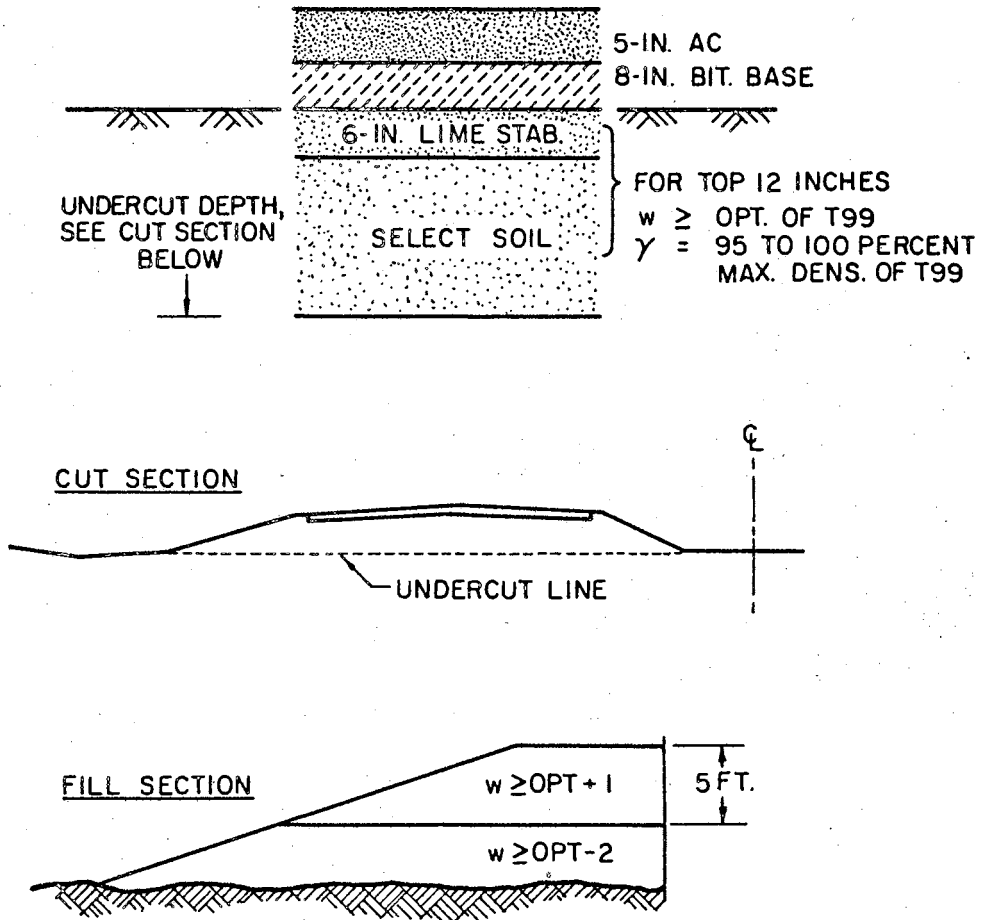

UPPER LIMIT OF MOISTURE CONTENT IS GOVERNED BY ABILITY OF CONTRACTOR TO ACHIEVE THE REQUIRED STABILITY AND DENSITY (95 PERCENT OF T99 MAXIMUM)

SOIL	PIERRE SHALE & BENTONITIC CLAY, LL = 76
WATER TABLE	NONE FOUND
PRECIPITATION	17 INCHES A YEAR
PERFORMANCE	UNKNOWN, PROJECT NOT COMPLETED

Figure 2.6. Current Fill and Pavement Designs in South Dakota

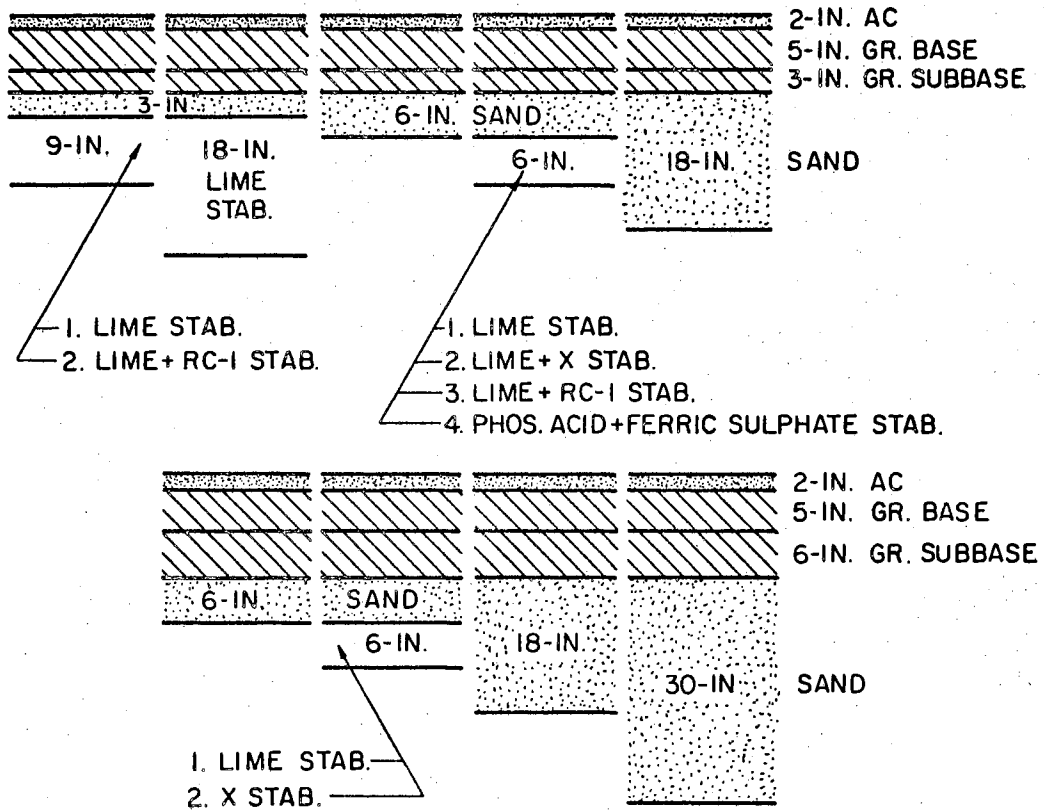

SOIL	PIERRE SHALE, A-7-6(20), AVG. LL=98 MONTMORILLONITE CLAY
WATER TABLE	VERY DEEP
PRECIPITATION	20 TO 25 INCHES A YEAR
PERFORMANCE	UNKNOWN, CONSTRUCTED IN 1964

NOTE: "X" IS A COMMERCIAL ADDITIVE

Figure 2.7. Experimental Pavement Designs in South Dakota

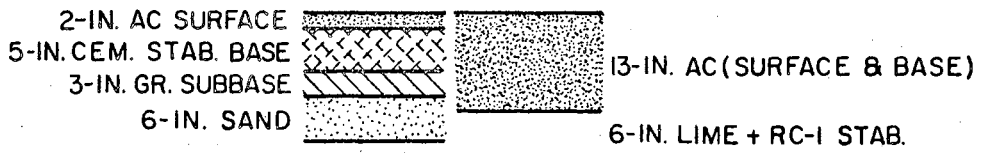
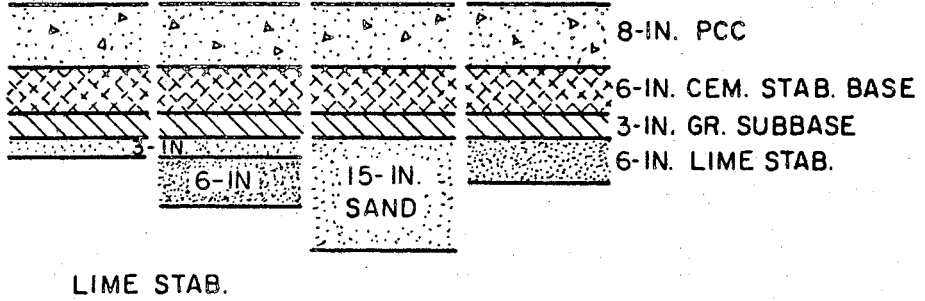

SOIL	PIERRE SHALE, A-7-6(20), AVG. LL = 98 MONTMORILLONITE CLAY
WATER TABLE	VERY DEEP
PRECIPITATION	20 TO 25 INCHES A YEAR
PERFORMANCE	UNKNOWN, CONSTRUCTED IN 1964

Figure 2.8. Experimental Pavement Designs in South Dakota

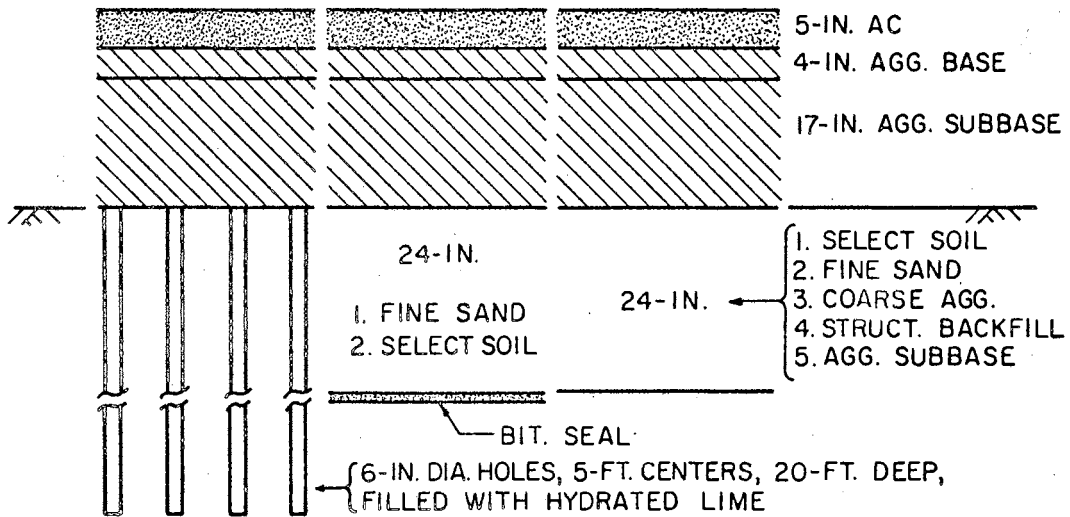
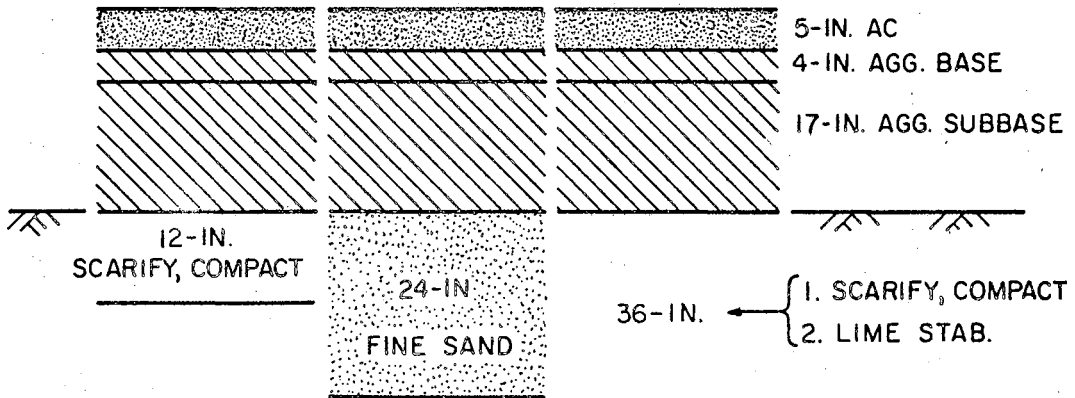

SOIL	MANCOS SHALE, LL= 35 TO 50, PI= 15 TO 27
WATER TABLE	VERY DEEP IF ANY
PRECIPITATION	5 TO 10 INCHES A YEAR
PERFORMANCE	UNKNOWN, CONSTRUCTED IN 1964

Figure 2.9. Experimental Pavement Designs in Colorado



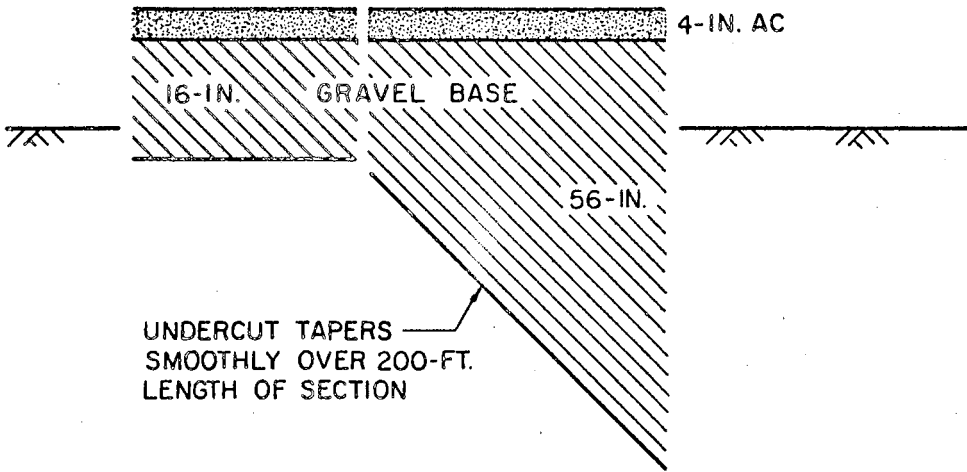
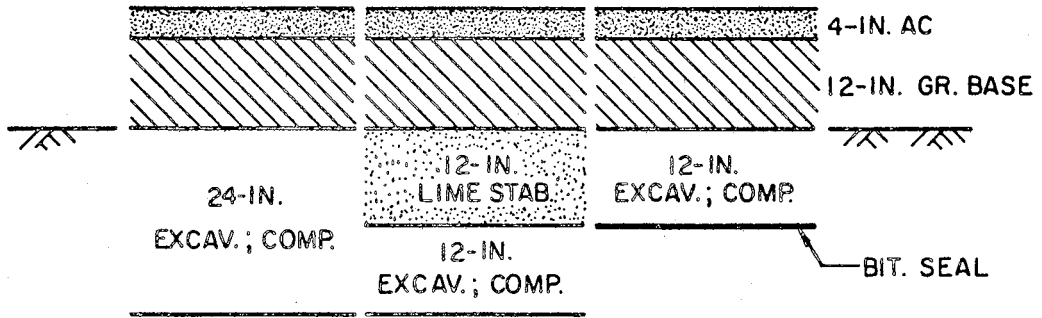

SOIL	MANCOS SHALE, A-7-6(20) LL = 36 TO 125 PI = 13 TO 103
WATER TABLE	—————
PRECIPITATION	15 INCHES A YEAR
PERFORMANCE	UNKNOWN, CONSTRUCTED IN 1964

Figure 2.10. Experimental Pavement Designs in Utah

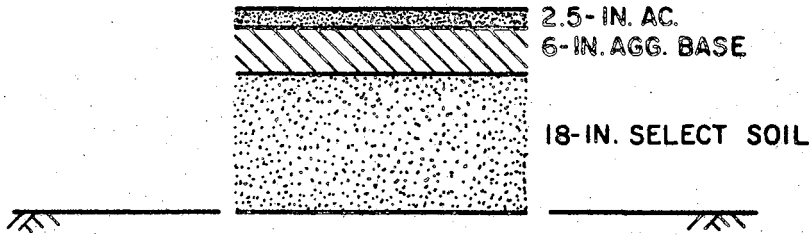

IN CUTS, PREVENT SUBGRADE MATERIAL FROM DRYING. SPRINKLE AS NEEDED, PLACE SELECT MATERIAL AS SOON AS POSSIBLE.  $\gamma = 95$  PERCENT OF T99 MAX.

IN EMBANKMENTS, DISINTEGRATED OR DRY MATERIAL IS NOT USED

SOIL	CHINLE SHALE, A-7-5 AND A-7-6 LL = 63 TO 82, PI = 38 TO 50 MAINLY MONTMORILLONITE CLAY
WATER TABLE	UNKNOWN
PRECIPITATION	4.5 INCHES A YEAR
PERFORMANCE	FAIRLY GOOD

Figure 2.11. A Current Pavement Design in Arizona

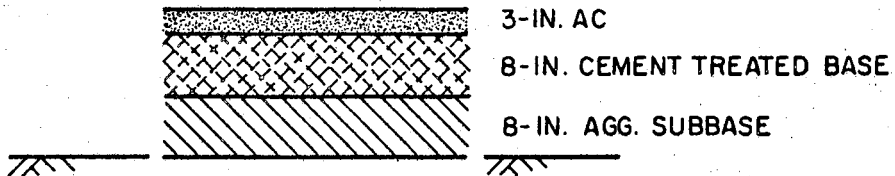

SOIL	UP TO 36 PERCENT < 0.005 MM., R-VALUE = 8
WATER TABLE	40+ FEET BELOW FINISHED GRADE
PRECIPITATION	20 INCHES A YEAR
PERFORMANCE	SATISFACTORY

DESIGN SECTION IS BASED PARTLY ON STRENGTH OF SUBGRADE SOIL AND PARTLY ON WEIGHT REQUIRED TO PREVENT EXPANSION AND WEAKENING OF THE SUBGRADE SOIL.

Figure 2.12. A Current Pavement Design in California

## CHAPTER III

### EFFECT OF PAVEMENT COMPONENTS ON SUBGRADE MOISTURE CONDITIONS

The performance of existing Oklahoma highways on expansive soils is definitely affected by subgrade moisture variations. To evaluate pavement performance, pavement components which affect subgrade moisture conditions must be analyzed. Only then can recommendations for future highway design be made.

Current Oklahoma highway design procedures involve the use of both flexible and rigid pavements. Both types are similar in that they are constructed of three major components; 1) surface wearing course, 2) base course, and 3) subbase. Actually, rigid pavements consist only of the concrete slab, however, prepared base and subbase components are often used in the highway structure for additional strength and a smooth working surface for paving operations. Many Oklahoma highways do not have subbase components, however, in recent years it has been standard procedure to include them in the pavement structure.

The surface wearing course is constructed of asphaltic concrete (AC) or Portland cement concrete (PCC). The thickness of the surface wearing course varies from two to six inches of Type A or Type C asphaltic concrete for flexible pavements and six to nine inches of Portland cement concrete for rigid pavements. A comparison of AC and PCC wearing surfaces is not the object of this evaluation, therefore

the following discussions will involve primarily the performance of underlying components.

Base course thickness varies from four to ten inches for both flexible and rigid pavements. Six types of material are commonly used in base course construction; 1) sand cushion, 2) hot sand asphalt, 3) asphalt black base, 4) soil cement, 5) stabilized aggregate, and 6) select material. Sand cushions consist of sandy material, all of which must pass the one inch sieve and contain 15% to 35% fine material passing the No. 200 sieve. Based on recent subgrade moisture research, the use of sand cushions in new pavement construction has been deleted from Oklahoma design criteria. Hot sand asphalt is a mixture of asphalt and mineral aggregate composed of sand, or sand and fine gravel, with or without mineral filler. Asphalt black base is a mixture of asphalt and mineral aggregate composed of coarse and fine aggregates with mineral filler. Soil cement is a mixture of Portland cement and soil, preferably sands or silts with less than 35% clay. Soil cement base courses are primarily used in construction of improved shoulders. Stabilized aggregate material consists of blended coarse aggregate, sand, mineral filler and soil binder. Select material is similar to stabilized aggregate, but is usually considered to be naturally occurring and governed by different specifications, depending on the particular requirements of a paving job.

As previously mentioned, many Oklahoma highways do not have subbases. Where subbases are used, they are constructed of select material or lime-treated layers of the subgrade. Subbase thickness varies from six to ten inches for select material and six to 24 inches for lime-treated layers.

The performance of the base and subbase is affected by the behavior of the subgrade. Conversely, conditions existing in the subgrade are affected by the presence of various base and subbase materials. The following sections are intended to clarify the relation between base, subbase, and subgrade moisture conditions.

### Base Course

Pavement base courses, used primarily to give additional strength to the system and transfer load to underlying layers, are either pervious, impervious, or some intermediate value, depending on the type of material used for base construction. Pervious base courses, properly designed and constructed, act as modified subsurface drains by collecting water and allowing it to be removed by gravity. Impervious base courses, properly designed and constructed, act as barriers against water infiltration.

Water can enter the base course by infiltration through pervious pavements, movement through cracks and joints in both pervious and impervious pavements, or as a result of seasonal movements of the water table. The latter source is from the zone of capillary rise, which often extends close to the ground surface. In Oklahoma the water table is generally 10 feet or more below the surface.

With the aid of a computer card sorting routine, described in Appendix A, effects of impervious and pervious base courses were easily separated. Of the 47 field research sites currently being studied, 35 have an average three-year pavement condition rating of good. Fourteen of these 35 sites have impervious base courses. The subgrade soil ranged from A-4 to A-7 with two sites located on A-1 and

A-3 material. Plastic limits for the expansive soils range from 15 to 30. The minimum moisture contents from field data collection varied from 10% to 15% with maximum variations in the range of 5% to 15%. The major portion of the variations were within a range of 5% to 10%. The moisture content/plastic limit ratios were approximately 1.0 in nearly all cases. Shaw and Haliburton (Ref 3) have stated that subgrade moisture content reaches an "equilibrium" value near a moisture content/plastic limit ratio of 1.1 to 1.3. If moisture contents are maintained at "equilibrium" values, volume change characteristics are relatively stable.

The effect of impervious base courses on subgrade moisture conditions is evident at Site No. 44. The two-lane highway is PCC over four inches of hot sand asphalt, with improved shoulders constructed of a double bituminous seal coat over seven inches of soil cement. The subgrade is a uniform A-7 soil with plastic limits in the range of 24 to 35 for the depth of investigation. Figure 3.1 shows the subgrade moisture variations at Site No. 44 since field site installation in June of 1967 for the pavement centerline. Subgrade moisture variations over the two and one-half year period are relatively constant at all depths across the width of the pavement. Reference to the original drilling logs indicate that a hard material was encountered at a depth of approximately two feet, probably shale as the highway is located in a hilly area where shale is abundant. This could contribute to the relatively uniform moisture variations. Though moisture variations are relatively uniform at lower depths, considerable variations occurred at the 1.5 foot level. This is probably a result of the non-continuous base course under the pavement and shoulder.

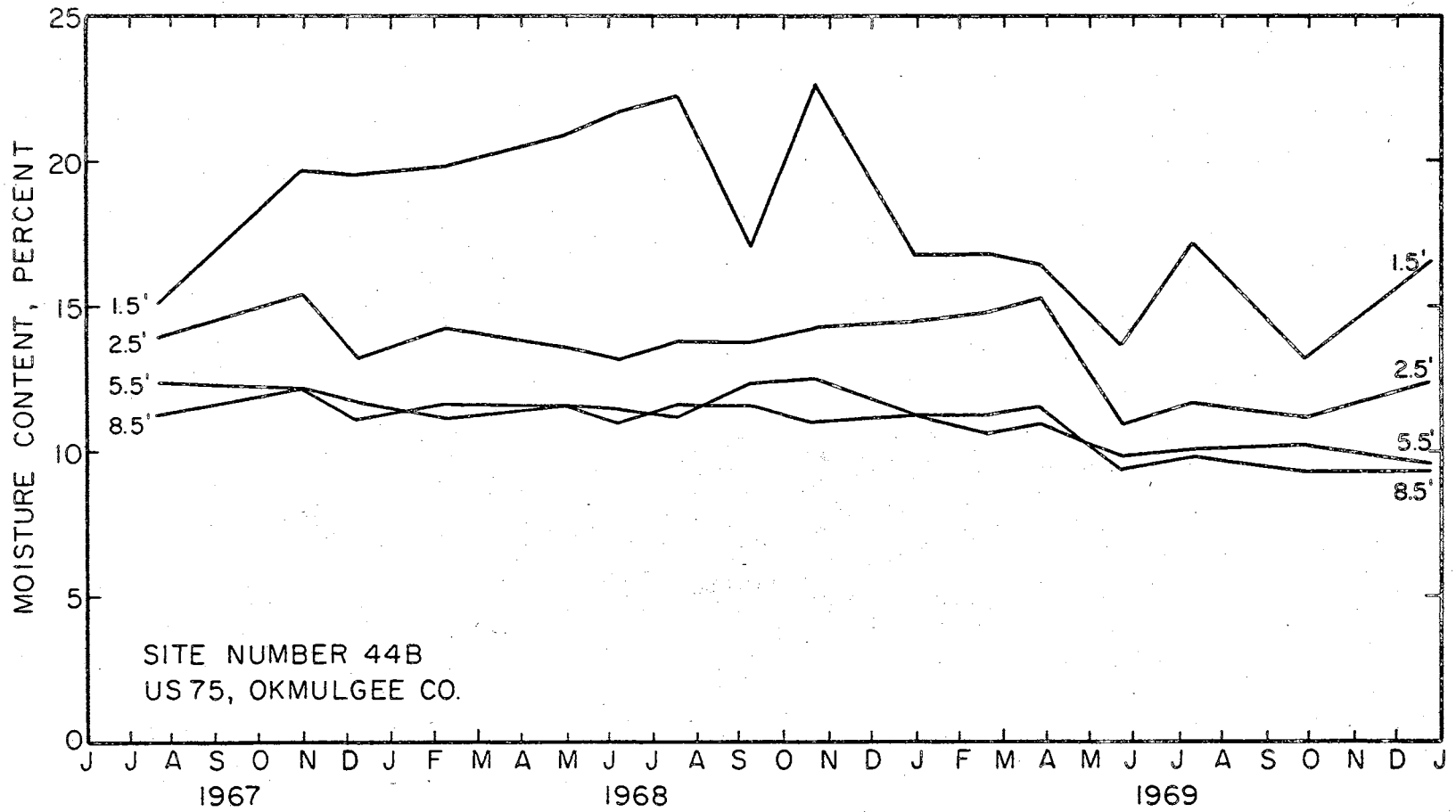

Figure 3.1. Moisture Variations at Selected Levels Beneath Pavement Centerline at Site No. 44

It should be noted that measured moisture contents at specific levels are an average value for the area influenced by the nuclear equipment used for field data collection, for example, the moisture content at 1.5 feet is actually the average moisture content for the soil between 0.5 and 1.5 feet. Likewise, at 2.5 feet it is the average value between 1.5 and 2.5 and so forth to the depth of investigation. In this particular case the 1.5 foot level includes a small portion of the hot sand asphalt base, which will affect the average moisture content to some extent.

The soil cement base course under the improved shoulders is rigid as compared to the flexible hot sand asphalt. Therefore, when volume change does occur, damage to the shoulder in the form of cracking and vertical movement will result. Once the shoulder has cracked or moved relative to the pavement, more water will enter and volume change will continue. At Site No. 44 both shoulders have cracked and moved up and away from the pavement as noted in Fig 3.2. At present only the upper one foot of subgrade has been affected, but with time and continued infiltration of water, moisture variations will move deeper and finally result in damage to the pavement. Increased moisture variations at the 2.5 ft level are evident after January, 1969, when appreciable shoulder movement was noted.

Site No. 41 is another example of impervious base components. However, in this case the base course is continuous under pavement and shoulders. The divided four-lane AC highway is constructed of 4.5 inches of asphaltic concrete over seven inches of asphalt black base and ten inches of select material subbase. The subgrade is a uniform A-7 soil with plastic limits in the range of 17 to 27. The minimum



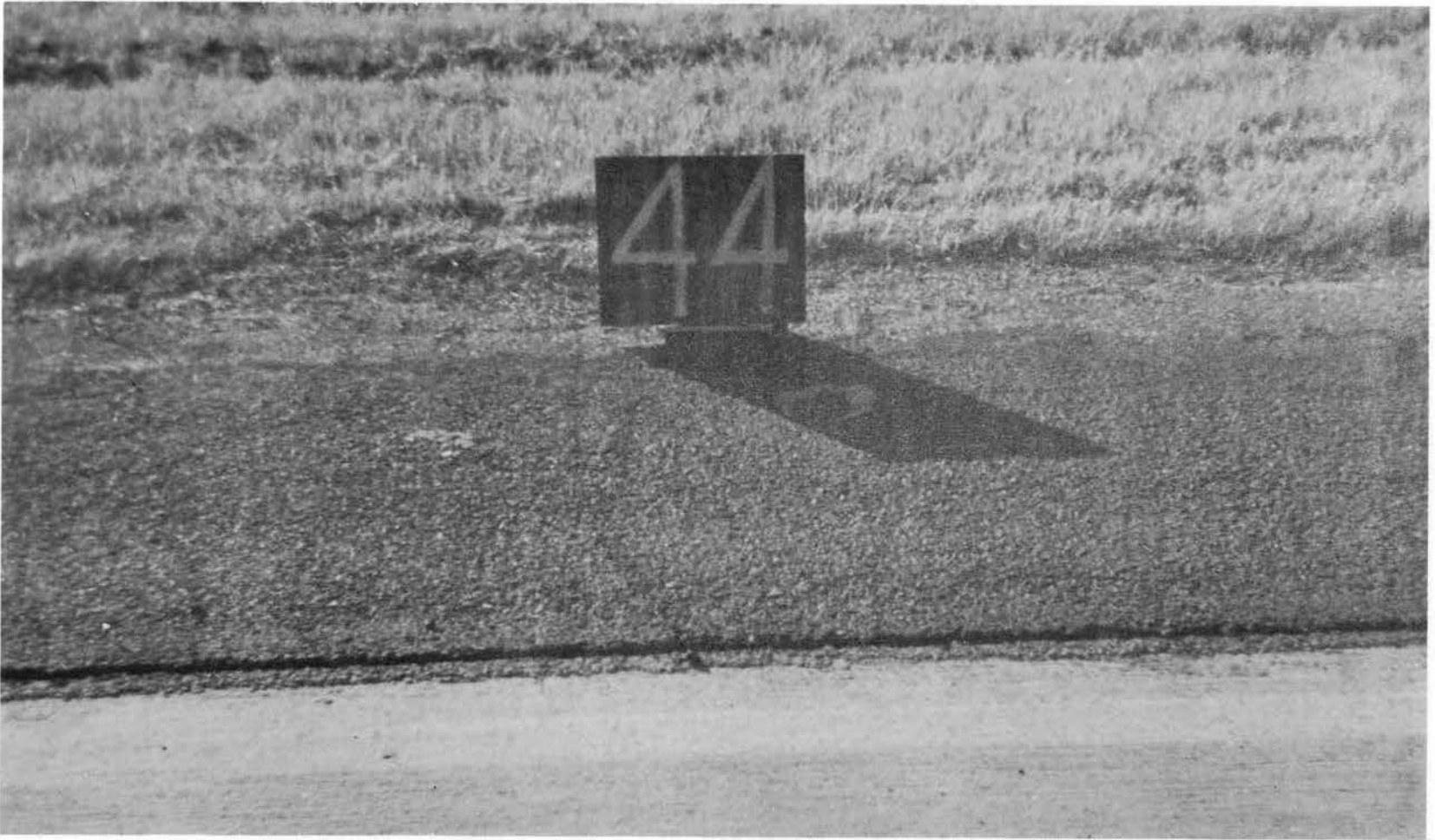

Figure 3.2. Differential Movement of Shoulder at Site No. 44

measured moisture content for the centerline at a depth of 2.5 feet is 12.2% with a maximum of 19.6%. It may be noted from Fig 3.3 that the subgrade moisture variations are rather uniform beneath the centerline and edge of the pavement. The moisture contents at a depth of 2.5 feet are approximately the same at both locations, therefore, infiltration between the pavement and shoulder can be greatly reduced as a result of continuous base courses.

Pervious base courses existed under 14 of the 35 highways rated good. The subgrade soil ranged from A-6 to A-7 with two sites on A-4 and two sites on A-3 material. The plastic limits varied between 15 and 25 for the expansive soil subgrades. The minimum moisture content at a depth of 2.5 feet varied between 10% to 20%, with maximum moisture variations in the range of 5% to 15%. In this case, as in impervious bases, the moisture content/plastic limit ratios were approximately 1.0. However, it may be noted that for these designs the minimum moisture contents were higher at the 2.5 foot level than at the 1.5 foot level. This could be attributed to the fact that fine material (clay size) is present in the base in high enough percentages to prevent proper drainage, thus allowing moisture accumulation to occur below the base. This moisture accumulation provides water to the upper layers of the subgrade and often causes problems with swelling. An example of this type of behavior is apparent at Site No. 21. The divided four-lane highway is constructed of PCC over an eight inch sand base course with no subbase and has improved shoulders constructed of a double bituminous seal coat over stabilized aggregate. The subgrade is a uniform A-6 soil which has a plastic limit range of 14 to 20 over the depth of investigation. Figure 3.4 shows the subgrade moisture

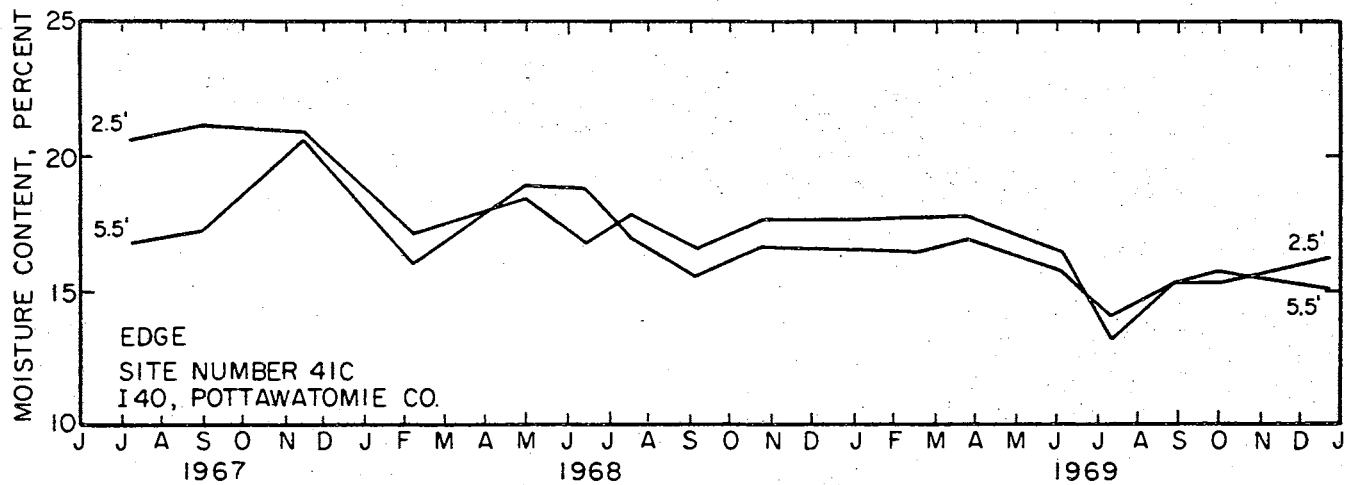
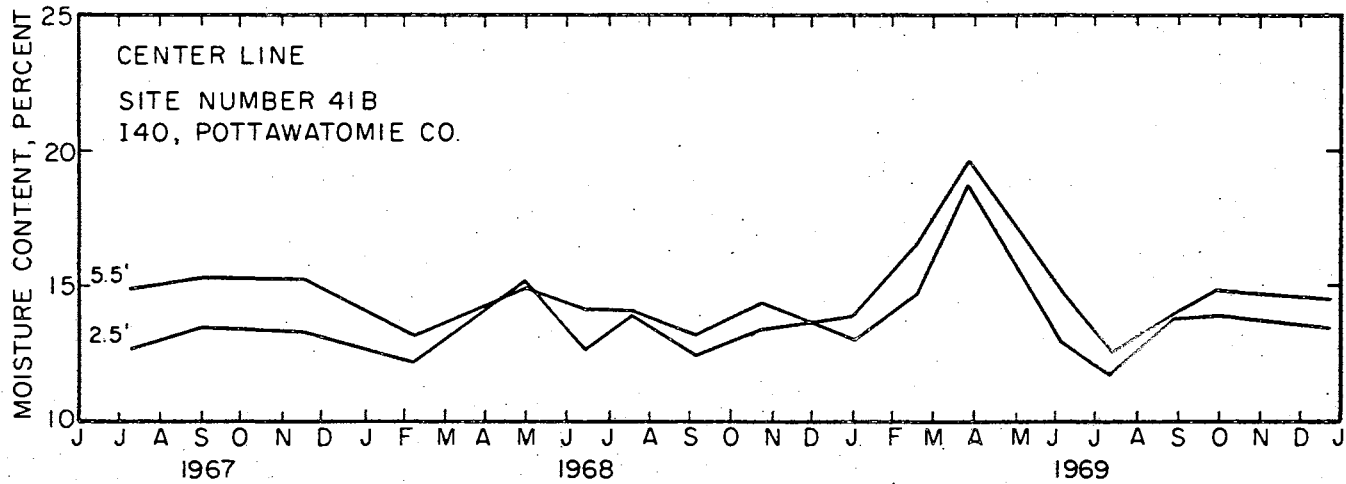

Figure 3.3. Moisture Variations at Selected Levels Beneath Pavement Centerline and Edge at Site No. 41

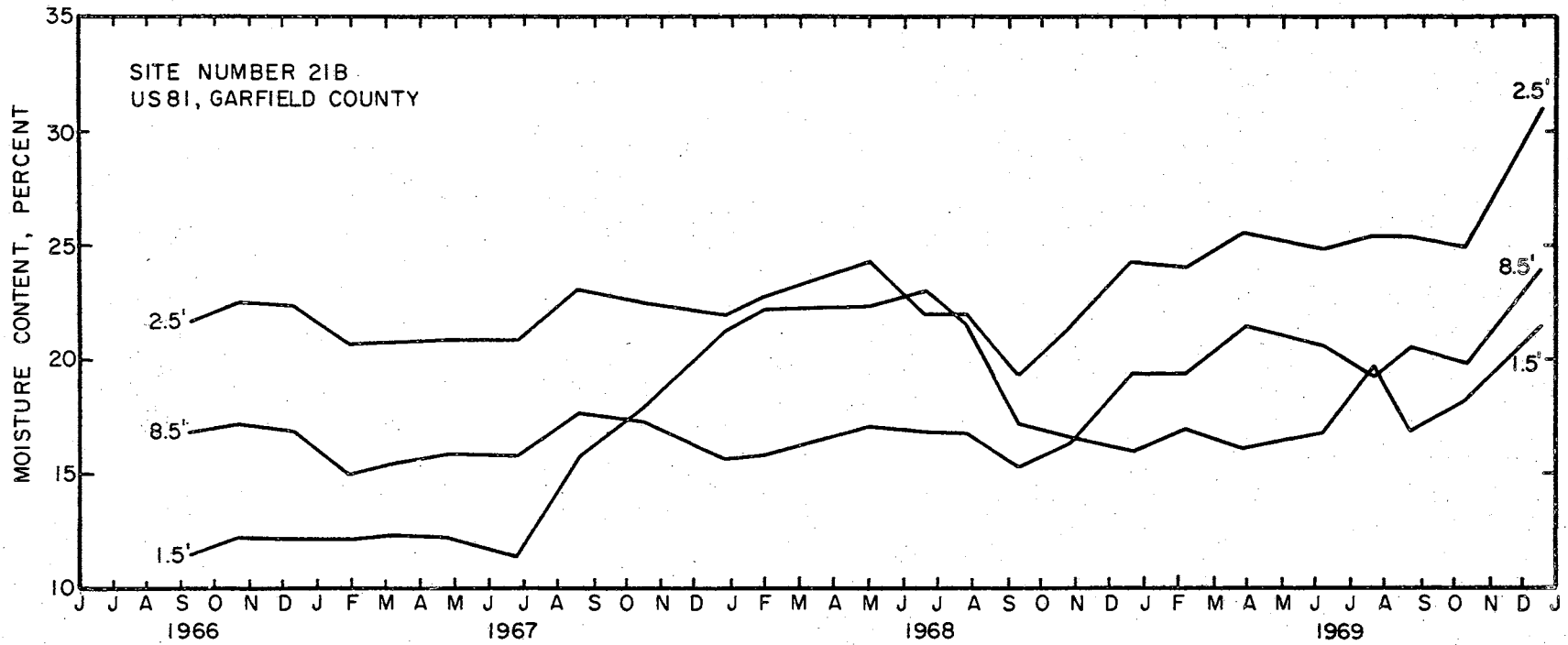

Figure 3.4. Moisture Variations at Selected Levels Beneath Pavement Centerline at Site No. 21

variation at selected levels under the centerline since installation in September of 1966.

From Fig 3.4 the accumulation of moisture at the 2.5 foot level is evident when comparison is made with moisture contents at the 1.5 foot level, particularly since September of 1968. The erratic moisture conditions at 1.5 foot level are indicative of precipitation-dependent variations. The increase at the 1.5 foot level occurred approximately four to six weeks after above average precipitation fell on the area. During May, June, July, and October of 1967, the average monthly precipitation was 3.0, 7.5, 3.8, 6.5 inches respectively. It is evident from Fig 3.4 that the moisture accumulation at the 2.5 foot level began to occur shortly after the higher variations occurred at the 1.5 foot level. The lower moisture contents at greater depths indicates that influence from the water table is insignificant. The continued increase in moisture content is probably the result of movement of water through cracks and joints which opened due to swelling of the subgrade from initial moisture accumulation. A major portion could have been prevented by proper joint and crack maintenance during seasons of above average rainfall. Another solution to the problem would be the use of a prepared subbase to act as a barrier against infiltration into the subgrade.

#### Subbase

Subbase components are used primarily as a means of distributing loads to the subgrade, but can also act as barriers against water infiltration where pervious base courses are used.

Subbases are usually constructed of locally available select material, as previously described, or chemically treated layers of the subgrade. Construction of select material subbases is relatively simple and includes the movement and compaction of six to twelve inches of material on the road bed. Chemical treatment, usually with lime, is carried out by scarifying the subgrade, mixing the lime, and re-compacting the final mixture. Most chemical treatments are successful to depths of six to twelve inches, however, the Oklahoma Highway Department is studying lime treatments to a depth of two feet.

The type of material used for subbase construction, which is usually "poorer" in quality than that used for base courses and wearing surfaces, is not the major factor affecting the performance of highways. Instead, the problem is whether or not to include them in the pavement structure.

Subbases are an integral part of flexible pavements, therefore higher quality subbases would in turn reduce the required base course or wearing surface thickness. In rigid pavements, the subbase as well as the base course is not considered as part of the pavement. However, the use of prepared subbases greatly enhances the performance life of the highway, particularly where pervious base courses and expansive subgrades exist.

Of the 35 field research sites presently being studied with pavement condition ratings of good, 13 sites do not have subbases while 22 have either select material or lime treated subbases. It should be noted that whether or not subbases are used in the subgrade is compacted to meet requirements for the particular job.

Though a number of good highways do not have subbases, the use of the component is definitely advantageous. The fact that subbases affect subgrade moisture variations is evident in the comparison of conditions existing at Site No. 39 and Site No. 40. Site No. 39 is a divided four-lane PCC pavement over four inches of sand and approximately eight inches of select material. The subgrade is a rather uniform A-6 soil with plastic limits in the range of 16 to 21. The minimum measured moisture content at centerline is 14.1% with a maximum of 19.6% at the 2.5 foot level. Site No. 40 is a divided four-lane PCC pavement over four inches of sand placed directly on the subgrade. The subgrade soil is a rather uniform A-6 soil with plastic limits in the range of 16 to 32. The minimum measured moisture content at centerline is 16.7% with a maximum of 37.5% at the 2.5 foot level. Site No. 39 was constructed in 1958 and Site No. 40 in 1962. Both highways are built on grade and located in level flood plain terrain with fair drainage conditions. Figure 3.5 represents the subgrade moisture variation at centerline for a depth of 2.5 feet for the two sites. From Fig 3.5 it may be noted that the overall moisture variation at Site No. 39 was relatively uniform with a maximum range of 5.5%, while at Site No. 40 it was quite erratic with a maximum range of 20.8%. Where subbases are not used and pervious base courses exist the subgrade is vulnerable to effects of precipitation and infiltration, resulting in higher and more erratic moisture conditions.

The effects of lime treatment on subgrade soils were discussed in the previous chapter and may be summarized as follows: the lime-treated layer forms a working surface for continuation of construction following rain; transfers enough water to the subgrade, as a result of

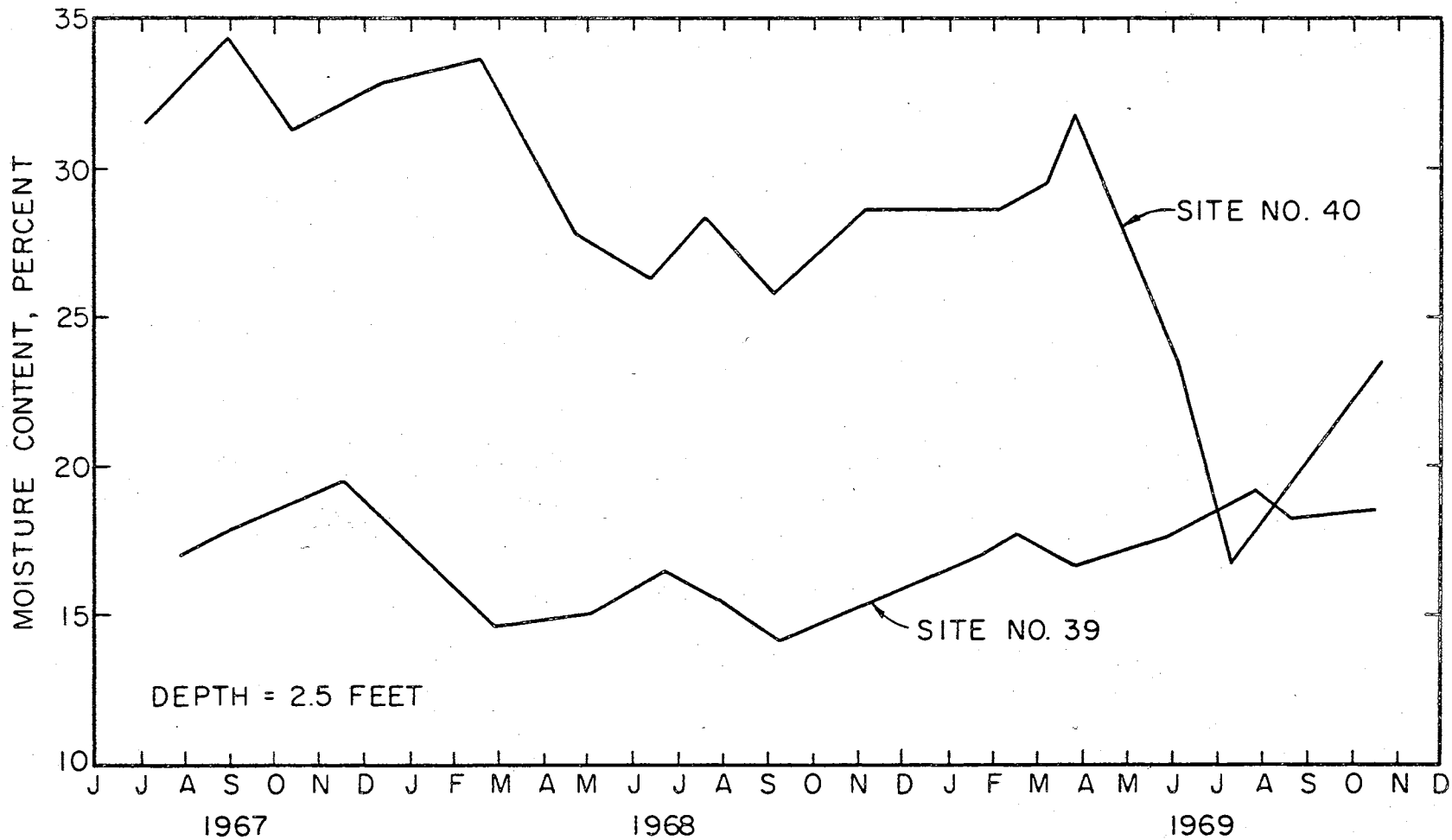

Figure 3.5. Moisture Variations at Depth of 2.5 feet Beneath Pavement Centerline for Sites No. 39 and 40



wetting for mixing purposes, to cause loss of some of the swelling characteristics; and forms a water barrier to prevent shrinkage cracking of subsoils due to drying, or infiltration of water during rainy seasons. The last of these effects is considered to be the most important, because the treated layer helps to prevent rutting of the pavement as a result of the loss of subgrade strength from excessive moisture in the upper regions of the subgrade, particularly under flexible pavements. Site No. 20 is an excellent example of a flexible pavement which has performed very well. The performance is definitely a result of the influence of lime-treated subbase on subgrade moisture conditions.

Site No. 20 is a divided four-lane highway with improved shoulders, constructed of 4.5 inches of asphaltic concrete over seven inches of asphalt black base and six inches of lime-treated subbase. The subgrade is a rather uniform A-6 soil with plastic limits in the range of 18 to 22. The improved shoulders are constructed of a double bituminous seal coat over 13 inches of select material base. Figure 3.6 represents the subgrade moisture variations at centerline for various depths at Site No 20. The increase in moisture content at the 1.5 foot level in the Spring of 1968 is probably the result of the influence of precipitation. The average monthly rainfall for March, April, May, and June of 1968 was above four inches and for the months following this period the precipitation averaged from one to three inches, which could account for the relatively uniform variation from August 1968 to December 1969. It may be noted that the range of subgrade moisture variations are relatively constant for the 3 1/2 year period; also, in the upper region the moisture contents increase with increasing depth, therefore

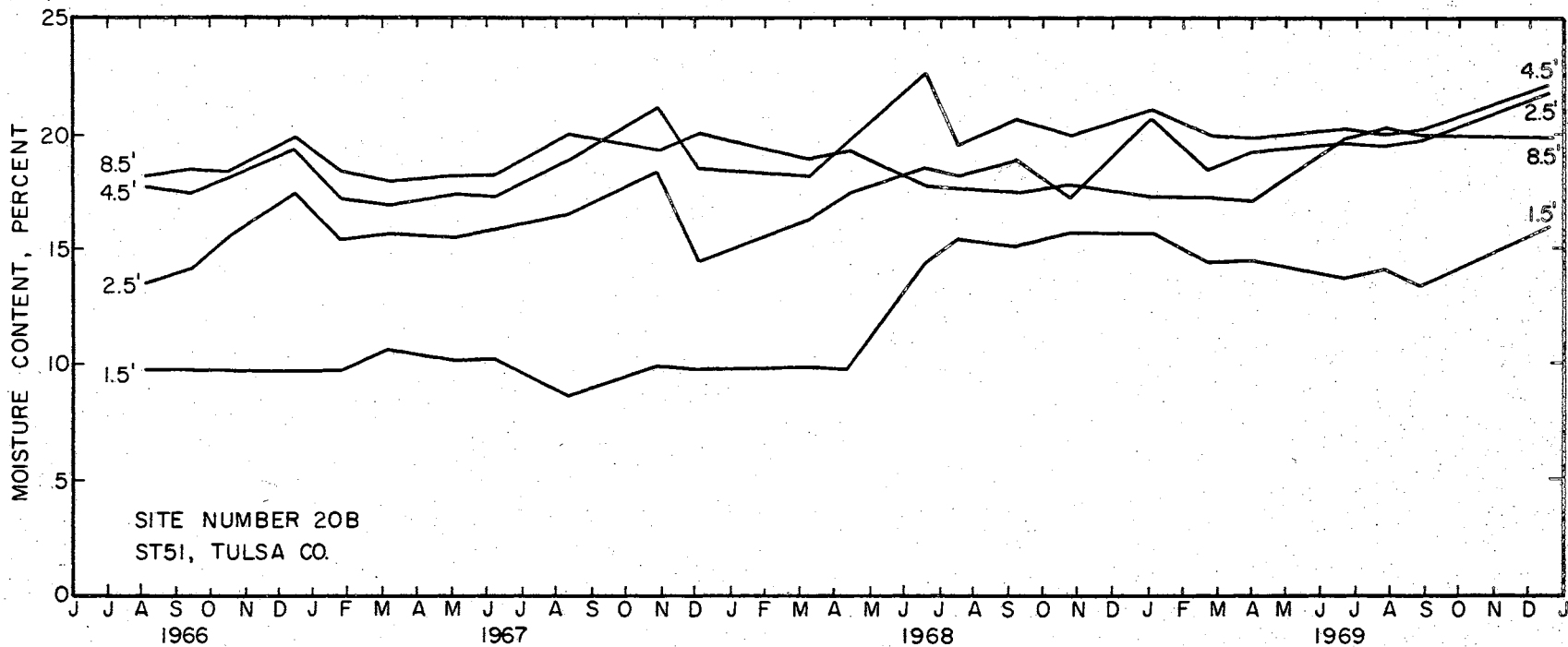

Figure 3.6. Moisture Variations at Selected Levels Beneath Pavement Centerline at Site No. 20

with moisture contents maintained at lower "equilibrium" values the volume change characteristics are stabilized.

For impervious base courses, unless cracking and infiltration has occurred, subbases have a different effect on the pavement structure. If infiltration is evident, the subbase will act as a protective barrier. If water enters from another source, for example from movement of the water table, the subbase will act as a "cushion" to protect the base and wearing surface from damage which could occur as a result of swelling or shrinking soils. A properly designed and constructed subbase should serve both purposes, whether pervious or impervious base courses are used.

#### Improved Shoulders

Improved shoulders provide a means of reducing infiltration of surface runoff into the subgrade, particularly at pavement edges. In most cases, reducing infiltration from this area permits more nearly uniform moisture variations over the width of the pavement and thus smaller differential volume changes where expansive soils are involved.

Present Oklahoma design procedures for improved shoulder construction provide a width of ten feet on both sides of two lane highways and widths of four feet and ten feet for divided four-lane highways, with the four foot width on the median side of the pavement.

Improved shoulders are constructed of either a double bituminous seal coat or a layer of asphaltic concrete for a surface wearing course. Base course materials include hot sand asphalt, asphalt black base, soil cement, stabilized aggregate, and select material.

Stage construction is often used in Oklahoma; as a result, improved shoulders are built after the paving process is completed. Since most construction is carried on during the spring and summer months, the shoulder subgrade is often exposed to drying conditions (unless preventative measures are taken) which can upset the moisture equilibrium. Following shoulder construction, subgrade moisture will vary and result in horizontal and/or vertical movement of the shoulder relative to the pavement.

Improved shoulders exist at 34 of the 35 sites with good pavement condition ratings. Shoulder performance is nearly as significant as that of the highway, therefore shoulder condition ratings were used to aid in evaluating overall highway performance. Good shoulder condition ratings exist at 23 field sites, fair ratings at 10 field sites, and poor ratings at one site.

The effect of improved shoulders on subgrade moisture conditions is evident in comparison of the range of moisture variations for Site No. 4 and Site No. 33. At Site No. 4 the two-lane highway is a PCC variable section pavement with open shoulders overlain with two inches of asphaltic concrete. The pavement is on a four inch sand base with no subbase over a uniform A-6 soil. The condition rating for Site No 4 is poor, which is a result of severe cracking and vertical movement which has occurred. Site No. 33 is a divided four-lane AC pavement with improved shoulders. The pavement is constructed over ten inches of stabilized aggregate base and a select material subbase. The subgrade is a uniform A-7 soil.

Figures 3.7 and 3.8 represent the range of subgrade moisture variations for Site No. 4 and Site No. 33 at a depth of 2.5 feet.

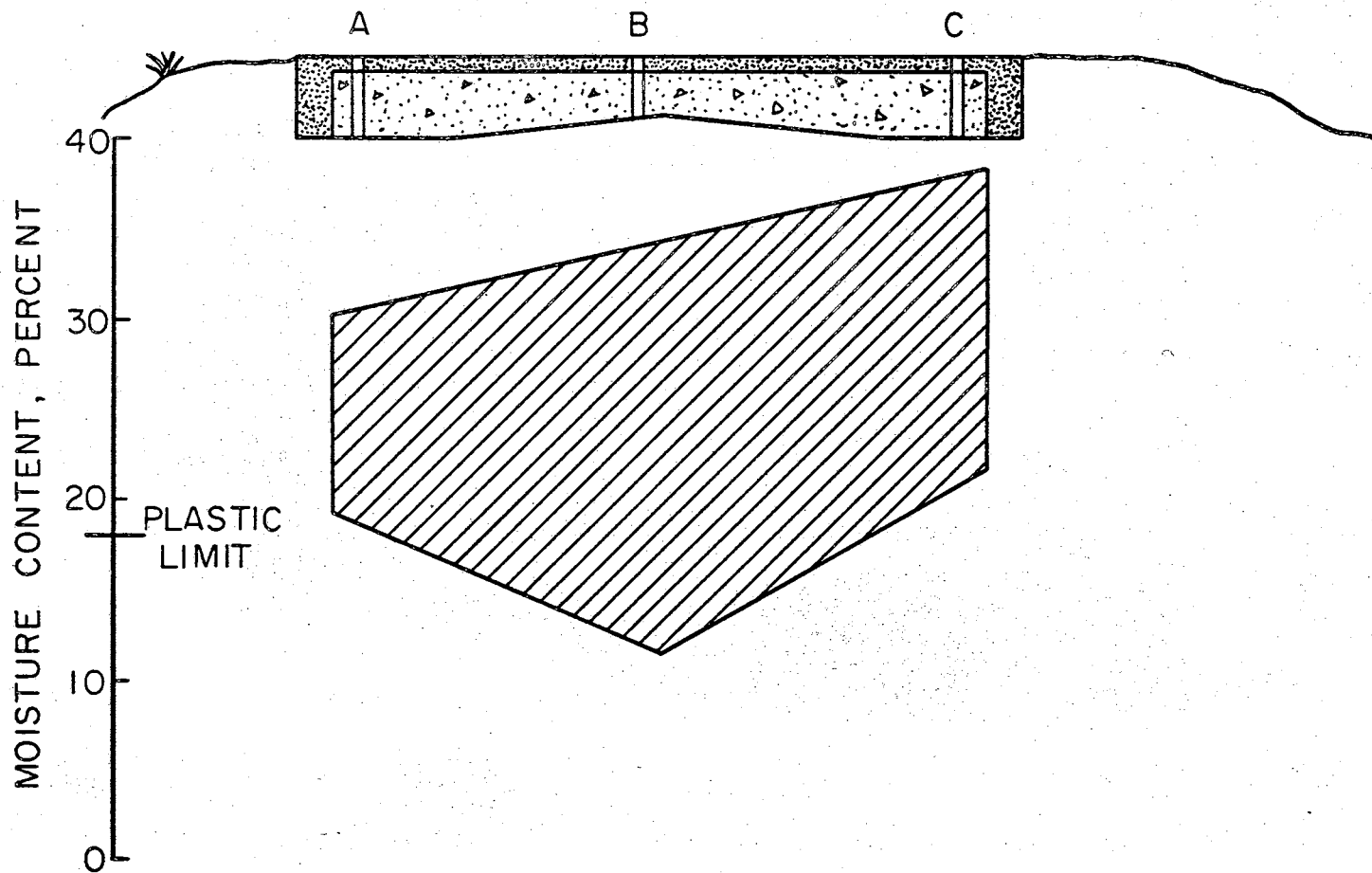

Figure 3.7. Range of Moisture Variations at Depth of 2.5 feet at Site No. 4

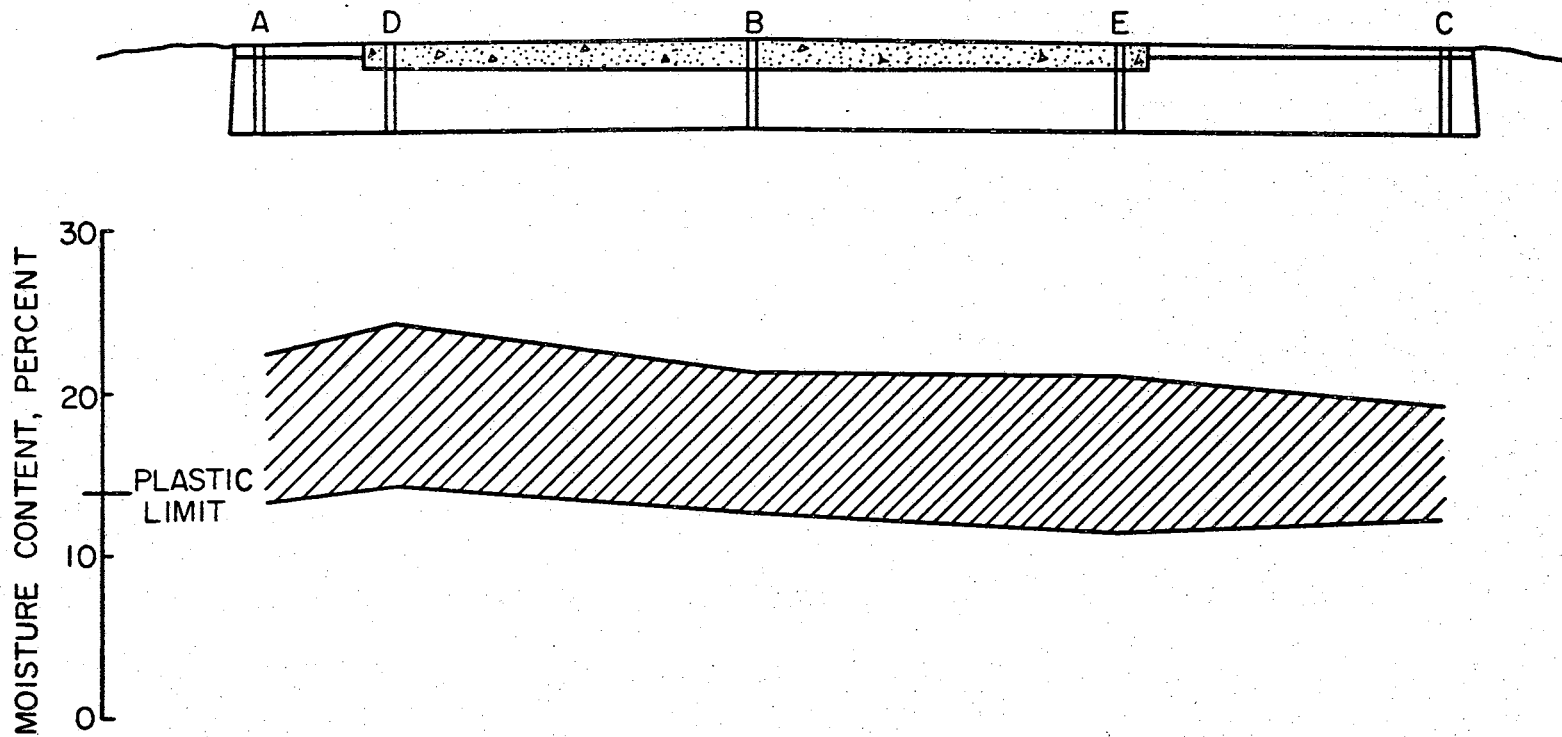

Figure 3.8. Range of Moisture Variations at Depth of 2.5 feet at Site No. 33

This depth was selected for comparison because most of the damaging effects from soil volume change occur in the upper five feet of the subgrade. The maximum moisture variation at centerline for Site No. 4 is 22.7% as compared to 8.4% for Site No. 33. It may also be noted that the range of moisture variation is considerably more uniform over the width of the pavement at Site No. 33.

Increasing shoulder width affects subgrade moisture conditions by decreasing the overall amount of moisture variation at the pavement edges, where damage is most likely to occur. The wet-dry interface, described by Dagg and Russam (Ref 8), can often cause serious problems with differential swelling, particularly when the condition occurs beneath the pavement. Wider shoulders aid in preventing the development of a wet-dry interface beneath the pavement. Therefore, the use of wider shoulders would definitely be advantageous.

Two examples which show the effect of shoulder width on subgrade moisture conditions are found at Site No. 37 and Site No. 38. Site No. 37 is located on a divided four-lane AC pavement constructed of 3.5 inches of asphaltic concrete over eight inches of hot sand asphalt base and six inches of select material subbase. The subgrade is an A-3 material to a depth of four feet and a rather uniform A-4 material below four feet. The plastic limits are in the range of 16 to 26 for the lower levels. Site No. 38 is located on a divided four-lane AC pavement constructed of 4.5 inches of asphaltic concrete over eight inches of hot sand asphalt base and six inches of select material subbase. The subgrade is an A-4 material to a depth of five feet and a uniform A-7 material below five feet. The plastic limits are in the range of 16 to 28 for the depth of investigation. Both sites have

continuous base courses and are built on grade in rolling upland terrain. Drainage conditions are good at both locations.

Figure 3.9 represents the range of subgrade moisture variations for a two and one-half year period at both locations. Figure 3.9 shows that the moisture variation at the pavement edges, indicated by arrows, is greater adjacent to the four foot shoulder than at ten foot width. From this and similar sections studied it is evident that wider shoulders are very useful in controlling moisture variation under the pavement edges.

#### Drainage Conditions

Drainage conditions and infiltration tendencies are closely related to shoulder and verge slope. Generally, steeper shoulder and verge slopes reduce infiltration into the subgrade by removing surface runoff as quickly as possible. Well designed and constructed drainage ditches also aid in quick removal of surface runoff and prevent ponding of water along the highway.

Site No. 12 is a prime example of "poorer" quality drainage conditions and their effect on subgrade moisture conditions. The two-lane AC pavement with improved shoulders overlies seven inches of asphalt black base with no subbase. The improved shoulders are constructed of a double bituminous seal coat over seven inches of asphalt black base. The subgrade is a uniform A-6 soil. Drainage conditions are rated fair. The east verge is gently sloping and has been observed to remain wet for extended periods following average amounts of precipitation, while the west verge is on a somewhat steeper slope with a relatively good drainage ditch.



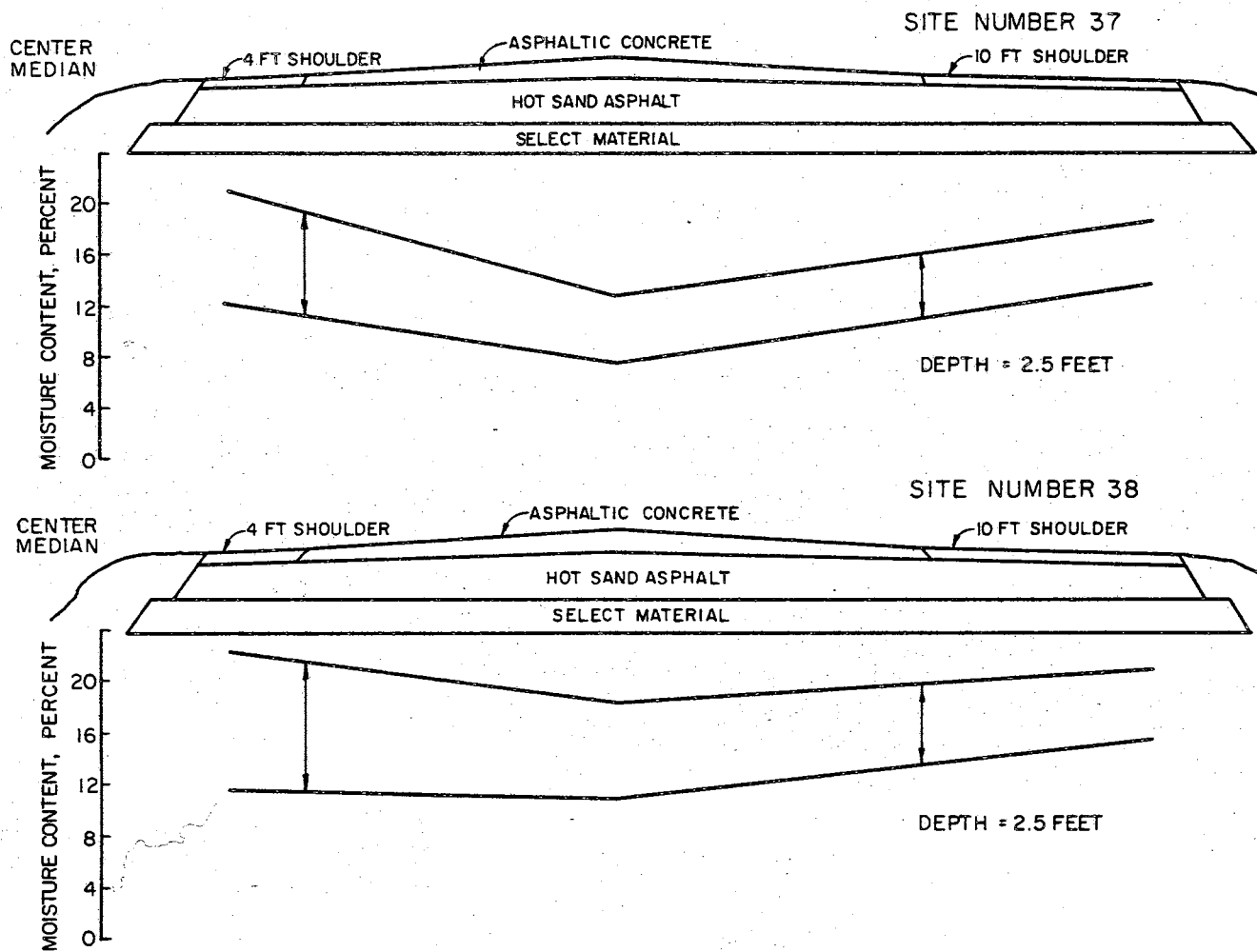

Figure 3.9. Range of Moisture Variations at Depth of 2.5 feet at Sites No 37 and 38

Shaw and Haliburton (Ref 3) state that a four to six week time lag occurs between the time precipitation falls and the time the subsequent moisture variation is realized in the subgrade when moisture variations are precipitation dependent. They also state that moisture conditions can vary with seasonal change. Subgrade moisture variations are affected directly by infiltration and climatic changes and indirectly by drainage conditions.

Figure 3.10 illustrates subgrade moisture conditions at Site No. 12 during the summer and winter for a depth of 2.5 feet. It can be noted from Fig 3.10 that during both seasons the moisture content is higher in the area of the east verge as compared to the west verge. During times of above average precipitation, which occurred during the months of May and June, the affect of drainage is more evident. This can be noted by comparing moisture contents under the east verge during June and July. The moisture content increased by 1.5% in a one month period while varying less than 0.5% under the rest of the pavement. This clearly illustrates the need for properly designed and constructed verge slopes and drainage ditches.

#### Summary

The performance of existing Oklahoma highways on expansive soils is affected by subgrade moisture variations. Evaluation of pavement performance with emphasis on subgrade moisture conditions must include an understanding of the highway structure, which may provide means for water to enter the subgrade and upset moisture "equilibrium" conditions. Problem areas and related factors are:

SITE NUMBER 12  
US66, CREEK CO.

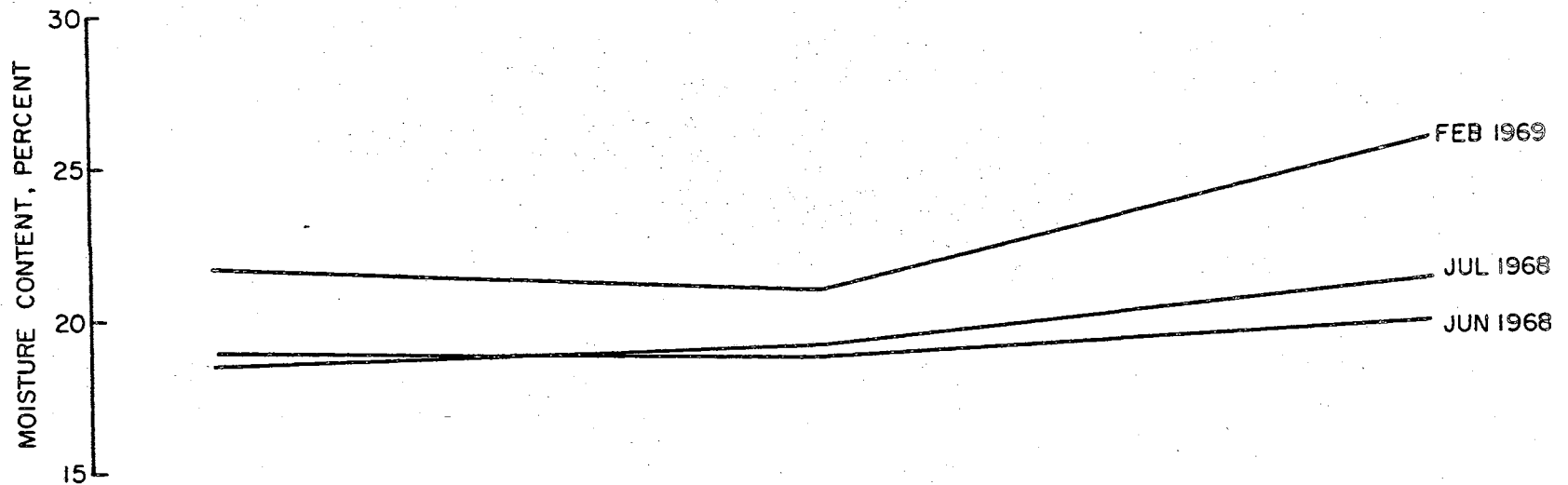
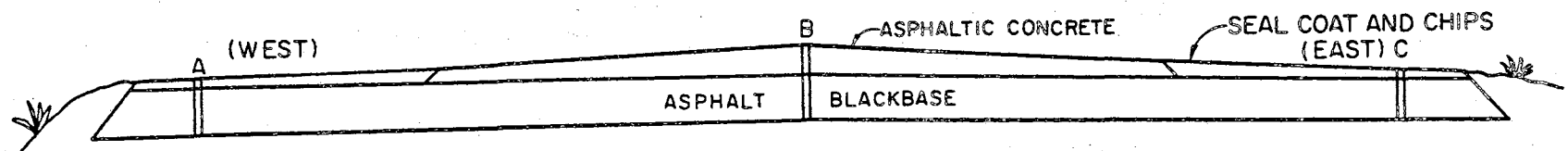

Figure 3.10. Subgrade Moisture Distribution at Depth of 2.5 feet at Site No. 12

1. Base courses; either pervious or impervious, rigid or flexible, discontinuous or continuous under the total width of the pavement and shoulder.
2. Subbase; whether or not to include in the highway structure and if included what effects does it have on moisture conditions,
3. Improved shoulders; whether they are useful in minimizing moisture variations, and
4. Drainage conditions; the extent to which they affect moisture conditions.

## CHAPTER IV

### EVALUATION OF PAVEMENT PERFORMANCE

The preceding chapter established a reasonable understanding of how pavement components affect subgrade moisture conditions. With this knowledge, various types of pavement components and materials can be compared and evaluated according to their purpose in the highway structure. Through this type of evaluation, it is possible to learn which combinations of structural components and materials perform best, where problem areas exist in present designs, and how they may be corrected.

To date, performance evaluations of existing pavements made in this research study have been concerned primarily with problems and failures which have occurred, rather than designs which actually work best. It is the purpose of this chapter to evaluate pavement performance considering only good pavements and emphasizing their subgrade moisture conditions and related factors.

Of the 35 field research sites with good pavement condition ratings, numerous combinations of surface, base and subbase components existed under both the pavement and shoulder. Varying drainage conditions were noted at all locations. With the aid of the previously described computer card sorting routine and a complete photograph and observation record for all field research sites, several combinations of components which performed better than others were recognized. In

nearly all cases, the type of surface course was not the most important factor. Instead, the underlying components seem to have the greatest influence on subgrade moisture conditions and overall highway performance.

Base courses under the better performing highways were found to consist of impervious and semi-impervious flexible materials such as hot sand asphalt, asphalt black base, and stabilized aggregate. The impervious and semi-impervious materials formed protective barriers against infiltration into the expansive subgrade and the flexibility of the material protected the pavement from direct influence of swelling pressures associated with expansive soils. Where rigid base materials such as soil cement were used, damage to the riding surface was more predominant and extensive. This was particularly true where soil cement was used for base material under improved shoulders. Continuous base courses under the pavement and shoulder were prevalent at most of the better performing highway locations. The use of continuous base courses is definitely advantageous in preventing moisture movement between the pavement and shoulder.

Subbase components were present under all the better performing highways. Both select material and lime-treated subbases were used and acted as additional water barriers and protection against damage to the upper layers from swelling pressures which develop in the subgrade.

Increasing shoulder width reduces the effects of surface runoff infiltration at the pavement edge and controls the amount of fluctuation which occurs as a result of moisture entering from shoulder slopes and verges. Also, wide shoulders inhibit the formation of a

wet-dry interface under the pavement. An optimum width of eight to ten feet seems to influence moisture conditions to the point that uniform moisture variations exist under the pavement and result in less severe differential movements. Again, the use of continuous base courses should be emphasized because the performance of the shoulder can be greatly affected when they are not included. The major damage resulting from expansive soils usually occurs in the area of improved shoulders. Extreme horizontal and/or vertical movement and cracking may result from expansion due to excess moisture entering between the shoulder and pavement. This damage can be greatly reduced by using continuous base components.

A qualitative evaluation of the effects of drainage conditions on pavement performance is rather difficult to undertake and is limited by data collection procedures used on this project. However, general trends in moisture behavior are relatively easy to recognize and clearly show the need for proper drainage. Properly designed and constructed ditches with appropriate slopes remove runoff water quickly and prevent "ponding" near the highway.

#### Summary

Highway performance and related trends in subgrade moisture behavior were discussed in this Chapter. The performance of various components in relation to subgrade moisture conditions was the primary concern of the discussion. Conclusions from this evaluation and recommendations concern further study of relationships between subgrade moisture behavior and highway performance are listed in the following Chapter.

## CHAPTER V

### CONCLUSIONS AND RECOMMENDATIONS

Evaluation of existing Oklahoma highways with emphasis on subgrade moisture conditions and related factors responsible for good pavement performance has produced the following conclusions:

1. Highways on expansive soils seem to perform better when constructed with impervious or semi-impervious flexible base courses. Flexible impervious material such as hot sand asphalt and asphalt black base and flexible, semi-impervious material such as stabilized aggregate perform well under both flexible and rigid pavements. These materials act to reduce infiltration and resist cracking better than rigid and/or pervious base courses.
2. Continuous base components result in better highway performance by reducing moisture movement between the pavement and shoulder and thus reduce the tendency for horizontal and/or vertical movement.
3. Soil cement base material placed directly on the subgrade is more susceptible to cracking and differential movement than are flexible materials.
4. Pervious base materials, such as sand, provide a means for moisture accumulation in the upper areas of the subgrade.



5. Subbase components contribute to better performance of pavement sections.
6. Increasing shoulder width reduces the effects of infiltration into the subgrade at the pavement edge. An optimum width of eight to ten feet seems to serve the purpose best.
7. Increasing shoulder width prevents the development of a wet-dry interface under the pavement.
8. Properly designed and constructed shoulder and verge slopes facilitate runoff to ditches and result in more nearly uniform and stable moisture conditions in the subgrade.

For better highway performance over expansive clay subgrades in Oklahoma, the following are recommended.

1. Whenever possible, continuous, flexible and impervious base courses should be used.
2. A prepared subbase course should be used under both flexible and rigid pavements.
3. Improved shoulders should be included in all highway sections, with a minimum width of eight to ten feet.
4. Recommendations for improved drainage conditions presented by Kassif, Livneh and Wiseman (Ref 4) and outlined in Chapter II should be followed.

For future study of pavement performance relating to moisture conditions in Oklahoma subgrades, the following are recommended:

1. Data collection at sites which have special instrumentation should be continued until just before project termination.
2. If time and funds can be made available, highway test sections should be constructed and evaluated to test recommended highway design criteria.

## REFERENCES

1. Marks, B. D., and T. Allan Haliburton. "Interim Report IV: Evaluation of Collected Data 1966-1967." Subgrade Moisture Variations Research Project, School of Civil Engineering, Oklahoma State University, Stillwater, Oklahoma, May, 1968.
2. Osterhout, R. D., and T. Allan Haliburton. "Interim Report VII: Subgrade Temperature Measurement." Subgrade Moisture Variations Research Project, School of Civil Engineering, Oklahoma State University, Stillwater, Oklahoma, June, 1969.
3. Shaw, L. K., and T. Allan Haliburton. "Interim Report VIII: Evaluation of Collected Data 1966-1969." Subgrade Moisture Variations Research Project, School of Civil Engineering, Oklahoma State University, Stillwater, Oklahoma, February, 1970.
4. Kassif, G., Livneh, M., and G. Wiseman. Pavements on Expansive Clays. Jerusalem Academic Press, Jerusalem, Israel, 1969.
5. McDowell, C. "Stabilization of Soils With Lime, Lime-Flyash, and Other Lime Reactive Materials." Highway Research Board Bulletin 231. Washington, D. C., 1959.
6. Harris, F. A. "Asphalt Membranes in Expressway Construction." Research Record No. 7, Highway Research Board, Washington, D. C., 1963.
7. Sallberg, J. R., and Smith, P. C. "Pavement Design Over Expansive Clays; Current Practices and Research in the U.S." Proceedings of the International Research and Engineering Conference on Expansive Clay Soils, Texas A & M University, 1965.
8. Dagg, M., and D. Russam. "The Relation Between Soil Shrinkage and the Development of Surface Cracks in an Experimental Road in Kenya." RRL Bulletin No. 12, Hammondsworth, 1966.

APPENDIX

CODING CRITERIA FOR SORTING ROUTINE

## DATA CODING SYSTEM

- I. Site Number
- II. Pavement Condition Rating (Average for 1967, 1968, 1969)
  - 1. 90 to 100 (Good)
  - 2. 80 to 89 (Fair)
  - 3. 65 to 79 (Poor)
- III. Type of Pavement
  - 1. Asphalt Concrete
  - 2. Portland Cement Concrete
  - 3. Asphalt Concrete Overlay on Portland Cement Concrete
- IV. Type of Base Course Beneath Pavement
  - 1. Sand Cushion
  - 2. Hot Sand Asphalt
  - 3. Stabilized Aggregate
  - 4. Soil Cement
  - 5. Asphalt Black Base
  - 6. Select Material
- V. Type of Subbase
  - 1. None
  - 2. Select Material
  - 3. Lime Treated

## VI. Subgrade Soil Classification - Unified

1. CL
2. CH
3. ML
4. SF
5. SP
6. SW

## VII. Subgrade Soil Classification - AASHO

1. A-1
2. A-2
3. A-3
4. A-4
5. A-5
6. A-6
7. A-7

## VIII. Range of Plastic Limit (Average value for depth of investigation)

1. 0 to 10
2. 10.1 to 15
3. 15.1 to 20
4. 20.1 to 25
5. Above 25

## IX. Range of Liquid Limit (Average value for depth of investigation)

1. 0 to 20
2. 20.1 to 40
3. Above 40

X. Minimum Measured Subgrade Moisture Content at a Depth of 2.5 Feet (Hole A)

1. 0% to 10%
2. 10.1% to 15%
3. 15.1% to 20%
4. 20.1% to 25%

XI. Range of Measured Subgrade Moisture Variation at a Depth of 2.5 Feet (Hole A)

1. 0% to 10%
2. 10.1% to 15%
3. 15.1% to 20%
4. 20.1% to 25%

XII. Minimum Measured Subgrade Moisture Content at a Depth of 2.5 Feet (Hole B)

1. 0% to 10%
2. 10.1% to 15%
3. 15.1% to 20%
4. 20.1% to 25%

XIII. Range of Measured Subgrade Moisture Variation at a Depth of 2.5 Feet. (Hole B)

1. 0% to 10%
2. 10.1% to 15%
3. 15.1% to 20%
4. 20.1% to 25%

XIV. Minimum Measured Subgrade Moisture Content at a Depth of 2.5

Feet (Hole C)

1. 0% to 10%
2. 10.1% to 15%
3. 15.1% to 20%
4. 20.1% to 25%

XV. Range of Measured Subgrade Moisture Variation at a Depth  
of 2.5 Feet (Hole C)

1. 0% to 10%
2. 10.1% to 15%
3. 15.1% to 20%
4. 20.1% to 25%

XVI. Highway Cross-Section

1. Cut
2. Fill
3. Transition
4. Grade

XVII. Drainage Conditions

1. Good
2. Fair
3. Poor

XVIII. Date of Initial Construction

1. 1930-1939
2. 1940-1949
3. 1950-1959
4. 1960-1969



XIX. Average Daily Traffic (1968)

1. 0 to 2000
2. 2000 to 4000
3. 4000 to 6000
4. 6000 to 8000
5. Above 8000

XX. Shoulders

1. Open
2. Improved

XXI. Type of Base Course Beneath Shoulder

1. Hot Sand Asphalt
2. Stabilized Aggregate
3. Asphalt Black Base
4. Soil Cement
5. Select Material

XXII. Shoulder Condition Rating (Average for 1967, 1968, 1969)

0. Open
1. 90 - 100 (Good)
2. 80 - 89 (Fair)
3. 65 - 79 (Poor)

Site Number	Pavement Rating	Pavement Type	Pavement Base Type	Soil Type - Unified	Plastic Type - Unified	Liquid Limit Range	Min. Moisture Range	Moisture Variation Range-A	Min. Moisture Content-A	Moisture Variation Range-B	Min. Moisture Content-B	Moisture Variation Range-C	Min. Moisture Content-C	Highway Cross-section	Average Daily Traffic	Shoulder Type	Shoulder Base Type	Shoulder Rating				
01	1	2	1	1	3	4	2	2	2	2	2	1	3	3	1	0	0					
02	2	3	1	1	4	3	1	1	1	1	1	2	1	1	1	3	2	3	1			
03	1	1	2	2	1	4	3	2	2	1	2	2	4	1	4	3	2	1	1			
04	3	3	1	1	1	6	3	2	3	2	2	4	3	4	2	1	1	1	0	0		
05	3	1	3	1	1	6	3	2	1	3	2	3	2	4	3	1	1	2	2	3		
06	2	2	1	1	1	6	3	2	3	1	3	1	3	2	2	2	1	4	1	0	0	
07	2	3	3	2	1	6	4	3	3	1	3	1	4	1	1	1	4	2	2	2	1	
08	3	3	3	1	1	7	4	3	3	1	4	1	4	1	2	1	1	4	2	2	2	
10	1	1	3	2	1	6	3	2	2	1	3	1	2	1	1	1	3	4	2	2	2	
11	1	1	1	1	1	5	3	1	1	2	1	1	2	2	3	3	2	3	4	2	2	2
12	1	1	5	1	1	6	2	2	3	2	3	2	3	2	1	2	4	2	2	2	3	1
13	2	3	1	1	1	5	3	1	1	1	2	1	1	1	2	3	2	1	2	1	0	0
15	1	2	1	2	1	6	2	2	3	3	2	2	3	3	1	1	3	3	2	2	2	1
16	1	1	3	1	1	7	4	2	2	3	2	3	2	4	2	1	1	1	2	2	2	2
17	3	1	6	1	1	6	3	2	3	3	2	2	2	2	2	3	5	2	2	2	2	2
19	2	3	1	1	1	6	4	2	3	1	3	1	2	1	1	1	2	2	2	3	1	1
20	1	1	5	3	1	6	3	2	2	2	2	3	2	3	1	4	5	2	2	2	1	1
21	1	2	1	1	1	6	3	2	4	1	3	2	4	3	4	2	3	2	2	2	1	1
22	1	3	3	2	5	3	1	1	2	2	1	3	2	2	1	1	1	3	2	2	1	1
23	1	2	1	1	1	7	4	3	3	3	3	1	3	1	1	1	4	1	2	2	2	2
24	1	2	1	2	1	7	5	3	3	1	3	1	3	1	2	1	1	5	2	2	2	2
26	1	2	1	1	1	6	3	2	3	1	2	3	3	2	3	1	4	2	2	2	1	1
27	2	2	3	2	2	7	4	3	4	2	3	2	4	2	1	1	4	4	2	4	1	1
29	1	2	1	2	1	6	4	2	3	1	4	1	3	1	2	1	4	3	2	5	2	2
30	1	2	1	1	1	4	4	1	1	2	3	2	2	2	1	2	1	4	1	2	4	2
31	1	2	1	2	1	7	4	3	3	1	3	2	4	2	2	2	4	3	2	4	1	1
32	1	1	3	2	1	6	4	3	4	3	4	2	4	3	1	1	4	3	2	4	1	1
33	1	1	3	2	1	7	3	3	2	1	2	1	2	1	1	1	4	4	2	5	1	1
34	1	2	6	2	1	4	3	2	3	2	3	2	1	4	1	1	4	3	2	4	1	1
35	1	2	6	2	1	6	4	2	3	1	3	1	3	1	2	1	4	3	2	5	1	1
36	1	1	3	2	5	1	1	1	2	2	1	1	1	1	4	1	3	4	2	5	1	1
37	1	1	2	2	1	4	3	2	2	1	1	1	2	1	3	1	4	4	2	1	1	1
38	1	1	2	2	3	4	4	2	3	1	2	1	2	2	4	1	4	5	2	1	1	1
39	1	2	1	2	1	6	3	2	2	1	2	1	2	1	4	2	3	5	2	2	2	2
40	1	2	1	1	1	6	5	3	3	4	3	4	3	4	4	1	4	3	2	4	2	2
41	1	1	5	2	1	7	4	3	2	2	2	2	2	4	1	4	4	2	3	1	1	1
42	1	2	5	1	1	7	4	3	4	2	4	1	4	1	2	1	4	4	2	4	2	2
43	1	1	5	2	1	6	4	2	2	3	3	1	3	2	4	1	4	3	2	3	1	1
44	1	2	2	1	2	7	5	3	2	1	2	1	2	2	1	1	4	4	2	1	1	1
45	1	2	1	2	1	6	3	3	3	2	3	1	3	1	2	1	3	4	2	2	3	3
46	2	2	6	1	1	7	3	2	4	2	3	2	3	2	4	2	2	2	1	0	0	0
47	1	1	2	1	6	1	1	1	2	1	1	1	2	2	3	1	4	2	2	1	1	1
48	1	2	1	2	5	3	1	1	2	3	1	3	2	4	2	1	4	5	2	4	1	1
49	1	1	2	1	6	1	1	1	2	1	4	2	1	1	1	4	2	2	4	1	1	1
50	1	2	2	3	2	7	4	3	3	1	3	2	1	4	1	1	4	2	2	4	1	1
51	1	2	2	3	1	2	7	4	3	3	3	4	2	4	2	1	1	4	5	2	1	1
52	1	2	2	3	1	2	7	5	3	4	2	4	3	4	2	1	1	4	5	2	1	1

Input Data For Each Field Research Site

VITA

Donald Ray Snethen

Candidate for the Degree of

Master of Science

Thesis: A PERFORMANCE EVALUATION OF EXISTING OKLAHOMA HIGHWAYS

Major Field: Civil Engineering

Biographical:

Personal Data: Born in Kingfisher, Kingfisher County, Oklahoma, July, 19, 1946, the son of Milton and Mary Ann Snethen.

Education: Attended elementary school in Omega, Oklahoma; graduated from Omega Public High School, Omega, Oklahoma in May, 1964; received a Bachelor of Science Degree in Civil Engineering from Oklahoma State University of Applied Sciences and Agriculture on May 25, 1969; completed requirements for the Master of Science Degree in Civil Engineering in May, 1970.

Professional Experience: Worked with father on family's farm during summers until 1966; Research Assistant, Subgrade Moisture Variations Research Project, Oklahoma State University, Stillwater, Oklahoma, 1967-1970.