

Spring 1948

## Determination of The Proper Mixtures of Ellis County Soils For Adobe Construction

Buster W. Read  
*Fort Hays Kansas State College*

Follow this and additional works at: <https://scholars.fhsu.edu/theses>



Part of the [Physics Commons](#)

---

### Recommended Citation

Read, Buster W., "Determination of The Proper Mixtures of Ellis County Soils For Adobe Construction" (1948). *Master's Theses*. 411.  
<https://scholars.fhsu.edu/theses/411>

This Thesis is brought to you for free and open access by the Graduate School at FHSU Scholars Repository. It has been accepted for inclusion in Master's Theses by an authorized administrator of FHSU Scholars Repository.

DETERMINATION OF THE  
PROPER MIXTURES OF ELLIS COUNTY SOILS FOR ADOBE CONSTRUCTION

being

A thesis presented to the Graduate  
Faculty of the Fort Hays Kansas  
State College in partial fulfill-  
ment of the requirements for the  
Degree of Master of Science

by

Buster W. Read, A. B.

Fort Hays Kansas State College

Date May 14, 1948.

Approved Harvey A. Ginsger  
Major Professor

J. W. Albertson  
Chairman Graduate Council

CONTENTS

	Page
List of figures and tables-----	1
Acknowledgments-----	2
Introduction-----	3
Geological History of Ellis County-----	7
Collecting Samples-----	19
Determination of Soil Characteristics-----	22
Selection of Soil Material with Respect to Shrinkage-----	25
Stabilizers-----	37
Water Absorption Tests-----	39
Preparation for Erosion Tests-----	51
Erosion Tests-----	52
Painting-----	58
Conclusion-----	60
Bibliography-----	62

## LIST OF FIGURES AND TABLES

	Page
Figure 1. The Effect of the Addition of Sand on Shrinkage-----	31
Figure 2. Sketch of the Mixer Used to Mix the Sixty Pound Samples of Soil-----	35
Figure 3. Water Absorption Apparatus-----	41
Figure 4-11. Relation Between the Amount of Stabilizer and Percentage Increase in Weight-----	43-50
Figure 12. Apparatus for Erosion Test-----	53
Table I. Hydrogen Ion Concentration-----	24
Table II. Screen Analysis-----	24
Table III. Sand Soil Mixtures Necessary for Bricks That Will Not Crack-----	34
Table IV. The Percentage Increase in Weight in Absorption Tests-----	42
Table V. Table Showing the Results of Erosion Test-----	54

## ACKNOWLEDGEMENTS

I wish to express my sincere gratitude to: President L. D. Wooster of the Fort Hays Kansas State College for the use of material pertaining to my problem, Dr. H. S. Choguill for the use of certain chemical apparatus, Mr. Harold A. Rothgeb of the Soil Conservation Service, Dr. F. W. Albertson, Dr. G. M. Robertson, and Dr. F. B. Streeter for their helpful suggestions. My special thanks are due to Mr. William K. Zinszer, a ceramist, for numerous suggestions, and to Dr. Harvey A. Zinszer who suggested the problem and under whose direction the work was carried on.

## INTRODUCTION

The word adobe used so commonly in the Southwest originated in Spanish and Moroccan roots which meant "to mix" or "puddle", and later came to be applied to sun-dried brick or to a structure of that material.

In the puddled state the soil grains are brought close together so that there is a mechanical locking between the angular soil particles, and so that the surfaces in contact can be cemented by the clay in the soil. Soil used in making adobe bricks should contain clay or other soil components in sufficient quantities to cause the particles to adhere strongly when dried from a moist and plastic condition, but not in an amount that will cause cracking. Soils which produce bricks with friable and erodable surfaces, because of a lack of binding components or an excessive amount of sand, should not be used.

Sun-dried or Adobe bricks are large mud bricks dried in the sun and then laid up in courses in the wall with mud mortar or regular mortar treated to make it water-proof. These bricks are probably more widely used than all the other methods of earth construction. Their popularity results from two characteristics: (1) The exact amount of shrinkage in the brick is relatively unimportant as long as the unit remains intact and (2) the labor requirement is extremely variable, as one man or a dozen may be put to

work forming bricks with a minimum of equipment. A special kind of mixer is needed to mix adobe. With an ordinary cement mixer, the rolling barrel type, the mud has a tendency to form into a ball and roll around inside the barrel. If more water is added the mixture becomes too wet and slumps when the form is removed. A continuous cement mixer, a rotary bread mixer, or a plaster mixer is suitable.

Various sizes and shapes of bricks, to fit any odd places that may occur in construction, can be molded and laid up in the wall along with the standard size bricks. A rectangular brick four inches thick is the common size, though five and six inch thicknesses may be employed if the soil being used is of the proper type and greater attention is given to curing. The forms for shaping the bricks should be constructed from one inch lumber. The inside surfaces of the form should be lined with light sheet metal to keep the mud from adhering to the form. Standard size bricks are sometimes made with gang forms, where as high as three or four bricks are formed at one time. The form is removed immediately after the bricks are poured. If the form is not lifted straight up the brick will be deformed. Handles should be placed on the ends of the form to make removing easier. The standard-sized brick four by twelve by sixteen inches is a convenient size to handle. It weighs about fifty pounds and its volume is one half cubic foot

and has a wall face area of one half square foot when laid up in a wall. The computation of the quantity of brick required for any given wall is an easy matter. Smaller sized bricks are sometimes made to facilitate handling or because the soil is such that the larger sizes will crack badly.

The sun-dried brick method of adobe construction has been used successfully since the Civil War period (Long, 5). The use of stabilizers in the adobe bricks makes them waterproof and thus controls the erosion caused by hard driving rains. When a substance absorbs water and the water freezes, part of the material cracks off as the substance dries out. A typical example of this type of erosion can be found on buildings and even more noticeable on building foundations made from native limestone. This type of erosion in adobe construction causes the outside wall coverings, usually stucco, to crack off or pull away from the wall proper. Sometimes adobe bricks not treated with a stabilizer are painted on the outside to protect the bricks from erosion. Painting is not at all successful in localities that are subject to prolonged rain or damp weather or repeated freezing and thawing. Even though the wall erodes it may remain intact for many, many years, but it presents an unsightly appearance. With the use of a stabilizing substance the erosion due almost entirely to the absorption of water can be completely avoided and the unsightly appearance of the outside of an



adobe building does not occur.

Construction of buildings with stabilized soil has been used with much success in several sections of the United States. The purpose of this investigation was to determine whether the soils of Ellis County could be used to form waterproof soil blocks that might be used for construction. In the investigation eight soils found in the county were employed and several stabilizers added to each in varying amounts to determine if the specific soils could be rendered waterproof. Several types of paint finishes were tested. The work was divided into three main parts: (1) Survey of Ellis County Soils; (2) Selection of soil material with respect to shrinkage; and (3) Treatment of soils with respect to waterproofing.

## GEOLOGICAL HISTORY OF ELLIS COUNTY

The known geologic history of this area begins with the erosion of the pre-Cambrian basement rocks that occur below the Paleozoic sediments. This surface was submerged below sea level and marine sediments were deposited upon it. Throughout much of the Paleozoic era the area was successively submerged and elevated. Marine sediments accumulated during periods when the surface was below sea level, and these sediments were subsequently eroded during periods of emergence. The lower Paleozoic rocks consist for the most part of marine limestone, shale, and sandstone.

An important structural event is supposed to have taken place in this area during post Devonian-preMississippian time. This consisted of a regional arching of the strata along a northwest-southeast axis and is indicated by the fact that preMississippian erosion truncated the earlier Paleozoic rocks and stripped off all of the beds down to the Arbuckle limestone. This period of uplift and subsequent erosion is believed to have been followed by marine inundation and resulting deposition of the Mississippian strata over this part of Kansas. The rocks of northwestern Kansas were again uplifted and warped along this same general structural trend at the close of the Mississippian time or during the early Pennsylvanian time to form the structural feature now recognized as the

Central Kansas Uplift. The Mississippian strata believed to have existed across the top of this structure were stripped away by early Pennsylvanian erosion. At some places along the Central Kansas Uplift this early Pennsylvanian erosion cut away the rocks to such a depth as to expose the pre-Cambrian basement. Coarse clastic deposits accumulated along the flanks of the Uplift as a result of this period of erosion, and it is believed that they may have been contemporaneous with the denudation deposits that were spread out toward the east from the ancestral Rocky Mountains.

The sea again invaded the area and marine deposits accumulated across all of the northwestern Kansas during Pennsylvanian time. During the latter part of the Paleozoic, marine conditions were less prevalent and at times sediment accumulated on the surface of the land. Thus marine and non-marine deposits occur alternately throughout rocks representing upper Pennsylvanian and Permian time. Desiccation and continental type sediments became more prevalent throughout Permian time, indicating an intermittent but progressive withdrawal of the seas.

The sea withdrew completely from the area by the close of Paleozoic era and the surface was eroded, uplifted, and warped. Erosion proceeded throughout much of Triassic and Jurassic time and it was over this eroded land surface that the Cretaceous deposits were spread.

The contact between the Cretaceous and Permian rocks, where it can be observed in adjacent areas, is characterized by a weathered zone at the top of the Permian. This zone is several feet thick, gray in color, and transgresses the bedding planes, indicating a relatively long period of weathering. At many places a zone of pebbles or cobbles has been observed at the base of the Cretaceous deposits. These pebbles consist of quartzite and igneous rocks and probably represent the first phase of continental deposition.

During much of early Cretaceous time Ellis and Russell counties were still above sea level, where as marine deposits were accumulating to the south and southwest. As the early Cretaceous sea encroached northward, clastic sediments accumulated at and near the shore line as beach deposits, deltas, and off-shore bars. These deposits, in addition to near-shore channel and flood-plain deposits, constitute the Cheyenne sandstone. In central Kansas they probably accumulated during a period of stable sea level or when the shore line was moving slowly northward, and the Kiowa shale, which overlies and overlaps the Cheyenne, represents the sediments deposited under marine conditions as the sea more rapidly advanced and inundated this region.

The close of early Cretaceous time is marked by the withdrawal of the sea. It was not a continuous retreat but was marked by minor readvances, and left inter-

bedded marine and continental beds. Also it seems that the earth movements that occurred elsewhere at the close of Lower Cretaceous time may not have affected this area, because the Dakota formation, which is generally considered Upper Cretaceous in age, conformably overlies the Kiowa shale and is transitional with it. The Dakota formation is composed of continental and littoral beds deposited in channels, flood plains, beaches, lagoons and bars. Sand accumulated in stream channels or on beaches and bars, and clay, silt, and carbonaceous material were deposited on flood plains and in lagoons. The channel sandstones in general trend northeast, and the more evenly bedded bodies of sand that are believed to represent bar or beach deposits generally trend north or north-northwest. Thus the sandstones in the Dakota formation are elongate lenticular sand bodies interspread through the clay and silt.

Continental conditions existing throughout Dakota time again gave way to marine conditions and the upper part of the Dakota contains a larger percentage of even-bedded sand and silt suggesting beach or bar deposits. The sea completely transgressed the area for the last time and the Graneros shale and overlying marine formations of upper Cretaceous age were deposited.

Since the withdrawal of the Cretaceous sea this area has been continuously above sea level. It was subject to erosion during most of Tertiary time and was covered by a thin veneer of clastic sediments during the Pliocene.

These sediments represent material eroded from the highlands to the west and transported to western Kansas by eastward flowing streams.

During the Pleistocene the major streams crossing this area from west to east cut wide valleys and spread a thick layer of gravel and silt over their valley floors (Frye 3).

#### Sources of Sediments

There are four and possibly five sources of sediments: (1) terrigenous matter, or that derived from rock destruction, (2) matter of organic production; (3) volcanic materials; (4) matter from magmas; and (5) cosmic dust. Of these sources the first named has the great quantitative importance. Terrigenous sediments are rock fragments of the same composition as the rocks from which they were derived, mineral particles from these rocks, and derived decomposition products, the last mainly quartz, hydrous aluminum silicates, aluminum and iron oxides and hydroxides, and carbonates. The complexity of the mineral mixture increases with limitation of decomposition and prolongation of disintegration and transportation; prolonged decomposition reduces the complexity of the mineral mixture.

The products resulting from the destruction of igneous rocks are approximately 82 per cent shales, 12 per cent

sandstones, and 6 per cent limestones. In the destruction of the average igneous rock it does not follow that the products of destruction will be distributed as they exist in the average sediments.

Sandstones and quartzites, to the extent that they are composed of quartz sands, break up into grains of the same material, the grains in many, and perhaps most, instances being those originally deposited. These may attain the sites of deposition with no change other than reduction in volume. In so far as a sand rock is composed of minerals other than quartz, the products resulting from destruction will contain these substances or products of their decomposition.

The clay group of rocks contains hydrous silicates, some silicates derived from previous rocks, small fragments of quartz, some iron and aluminum oxides and hydroxides, and other substances in small percentages. The original silicates may remain unchanged or yield decomposition products. The iron compounds are likely to be in both ferrous and ferric form, and these yield iron hydroxides and oxides unless much organic matter is present, in which case iron carbonate may result. Some of the hydrous silicates may decompose to form oxides and carbonates.

Limestones and dolomites destroyed by mechanical

processes yield fragments of these rocks. If climatic conditions are favorable, the carbonates pass off in solution, leaving a residue of hydrous aluminum silicates, iron and aluminum oxides and hydroxides, and chert, the quantity of the last in some instances being extremely large.

Rock salt, gypsum, and similar substances usually pass into solution, leaving little residue. Chert is extremely resistant and enters the sediments in relatively large pieces. Under certain conditions some of the silica passes into solution, and the rock becomes porous or powdery, the color ranging from white to red.

All forms of rock destruction yield more or less sedimentary material of colloidal dimensions.

The Tertiary sediments of the Great Plains are among the best examples of valley flat sediments in the geologic column. These were first interpreted as lake deposits but are now rather generally assigned to stream deposition with some flood-plain lake deposits. They consist of clays, silt, sands, and gravels. Most sediments contain considerable lime which in some places has so cemented the gravel as to form the so-called mortar beds of Kansas.

The layer of wind-blown silt overlying the stream deposits of Western Kansas is called loess. The original materials of which loess is composed were probably acquired from many sources but chiefly from bordering dry regions,



the surfaces of ice sheets, and the outwash fans and floodplains of melt-water streams. The greatest known development of loess in the geologic column is in the Pleistocene era (Twenhofel, 6).

#### Origin of Shale

The shale which occurs in thin layers is formed by the consolidation of clay, mud, or silt, accompanied by a greater or less degree of recrystallization of the constituents and usually some enlargement of particles (Frye, 4).

#### Origin of Limestone

The limestones are mostly of shallow sea deposition. The most important factor in formation under favorable conditions being not the depth of the water, but the outwash of siliceous, aluminous and ferruginous materials from the land.

Limestones are produced by organic, inorganic and mechanical processes. Those of organic origin are accumulations of shelly matter. Limestones of chemically inorganic origin result from changes in the conditions of water in which calcium salts are dissolved, from agitation of water or from evaporation. Limestones of mechanical origin are formed by organic matter which has been picked up by wind and transported to be deposited in dunes. Most limestones develop from matter carried in solution. Limestone probably forms at times from finely divided calcium carbonate carried in suspension.

### Origin of Sandstone

Sandstone is a rock made up of small rounded or angular grains of mineral or rock fragments which have been derived from some pre-existing rock. Sandstones are but cemented and consolidated sands, mainly quartz.

### Origin of Silts

Silts are largely composed of rock dust and flour which have been produced by rock abrasion, grinding, and impact, and with these are particles of resistant minerals which have been released through the decomposition of the surrounding materials.

### Origin of Clays

The clays are composed of the very fine particles resulting from abrasion, grinding, and impact, and the minute mineral particles produced in rock decomposition. The major constituents are hydrous aluminum silicates, silicon dioxide, and ferric and aluminum oxides and hydroxides (Twenhofel, 6).

### Rock Formations of Ellis County

The rocks of the earth's crust fall into two groups: igneous and sedimentary. The igneous rocks have solidified from a liquid state; the sedimentary rocks have resulted from the integration of the products of destruction of the other rocks (Twenhofel, 6).

Rocks underlying the soil of Kansas are almost entirely sedimentary or stratified because they are hard-

ened sediments and they occur in layers (Frye 4). The rock formations of Ellis County follow and are listed in descending order.

#### Quaternary System

Deposits of gravel, sand, silt, and clay of the Recent Age occur along the valleys and underlie the flood-plains of the principal streams of this area, and occur also along the bottoms of some of the small stream valleys (Frye 3).

#### Tertiary System

Tertiary sand, gravel, and clay of the Ogalalla formation mark the eastern margin of the High Plains. This formation was spread out by streams heavily laden with debris from the recently formed highlands to the west in Colorado.

#### Cretaceous Rocks

The Niobrara formation of the Cretaceous system has been separated into two readily recognizable members, the Smoky Hill chalk above and the Fort Hays limestone below. The Smoky Hill chalk consists of marl beds alternating with chalk and the beds of clay. The Fort Hays limestone member consists of a massively bedded cream-colored chalk or very chalky limestone which is sixty million years old. The weathering of this limestone has contributed much to the soil.

Carlisle Shale is made up of chalky and clay shale,

about three hundred feet thick, that contains thin beds of chalk near its base, numerous zones of septarian lime concretions in its upper half and a unit of fine-grained sandstone at its top. The upper two-thirds is made up predominantly of gray-black fissile clay shale, and the lower third of chalky-shale and thin beds of chalky limestone. In Ellis County, the Carlile Shale is separable into the Blue Hill shale member above and the Fairport chalky shale member below. The Blue Hill shale member is made up of gray-black non-calcareous clay shale. The upper twenty-five foot layer contains gritty shale or sand stone. Fairport chalky shale is composed of calcareous shale including thin beds of chalky limestone.

Greenhorn limestone consists of four members: Pfeifer shale, Jetmore chalk, Hartland shale, and Lincoln limestone.

Pfeifer shale consists of alternating layers of chalky shale and chalky limestone. Jetmore chalk is interbedded chalky shale and chalky limestone. These beds are larger than the Pfeifer. Hartland shale is a series of chalky shales containing a few thin beds of soft chalky limestone and a few thin layers of bentonitic clays. Lincoln limestone is the basal member of the Greenhorn limestone and consists of chalky shales with thin beds of light-gray chalky limestone and of hard, finely-banded, dark-colored crystalline limestone.

A narrow strip in the south-eastern part of Ellis County along the Smoky Hill river is occupied by the Graneros shale. It is made up predominantly of blue-black fissile non-calcareous clay shale. Numerous thin lenses of sandy shale, sandstone, sandy limestone, and ironstone concretions are interbedded with the shale.

Dakota sandstone consists of massively-bedded fine-grained light-gray sandstone, containing an abundance of carbonized plant fragments, a zone of pyrite concretions embedded in sandstone and a layer of massive fine-grained sandstone. The Dakota sandstone of the Great Plains seems to have been deposited by streams flowing from the east, it has been differentiated into the flood-plain and the channel deposits (Bass, 2).

Kiowa shale overlies the Cheyenne sandstone and is overlaid by the Dakota formation. This shale is marine in origin and consists of dark-gray shale, silt and fine-grained sandstone.

Cheyenne sandstone, which is below the Kiowa shale consists dominantly of moderately well-sorted quartz sand but contains a few beds of shale and is light gray in color.

Under the Cheyenne sandstone are the Permian redbeds. They consist of alternating beds of red and gray sandstone, red siltstone and shale. They are distinguished from the overlying Cretaceous beds by their red-brick color and the fine texture of the sandstones (Frye, 3).

## COLLECTING SAMPLES

Eight types of soil that appear in Ellis County, Kansas, were tested. Seven of the eight types were found on the Fort Hays Kansas State College Farm. The other sample was found two miles north and one mile east of Hays, Kansas. Each of the samples taken from the Fort Hays Kansas State College Farm was located with the aid of a Soil Map prepared by the United States Soil Conservation Bureau. Samples were taken from the center of large areas known to be of a specific type. Owing to the poor cultivating properties of the soil north and east of town it was tested for useability in adobe construction.

The top soil was removed in each of the cases to a depth where no grass roots or plant matter was found. This depth varied from ten inches to two feet. A seventy-five pound sample of each type was taken. The samples were stored in bushel baskets. A description of each sample and of the field conditions where they were collected follows:

## Boyd clay loam

Even though the top soil was very dry, the subsoil was wet. The color of the sample was dark yellow and a few pieces of limestone were noticed in the sample. The sample was taken from a plowed field on which the last crop was wheat. The field sloped but it was not great enough

to cause erosion by water.

#### Crete silty clay loam

The top soil was very dry but the subsoil was damp. The soil was black, sticky and adhered to the shovel. No limestone particles were noticed and when the sample dried the clods were not very hard. The sample was taken from a flat, plowed field.

#### Hall silt loam

The top soil was very dry and the subsoil was only damp at twenty inches and the color was very black. The soil crumbled into granules and no limestone particles were found in the sample. The field was under cultivation and was flat.

#### Hastings silty clay loam

The subsoil was wet and grayish-yellow in color and a few limestone particles were found. The sample was taken from a field that was under cultivation and located near a draw. Erosion by water was noticeable.

#### Rokeby silty clay loam

The top soil was dry while the subsoil was only damp. The soil was light-gray in color and contained no limestone particles. The field where the sample was taken was flat and under cultivation.

#### Colby silt loam

The subsoil was damp and gray with a slight yellow color and no limestone particles were noticed. The sample

was taken from a pasture of native grass, near a draw.

Colby silt loam (red)

This sample was found north and east of Hays and was taken from a pasture of native grass. The subsoil was damp and reddish in color. There was a large quantity of limestone particles which were extremely small; not pebbles as in the other samples where limestone was present.

Tripp silt loam

Beneath the grass roots the soil was damp and contained a large amount of very fine sand. The soil sample was taken on the bottom land adjacent to Big Creek.



## DETERMINATION OF SOIL CHARACTERISTICS

One-hundred gram samples were taken from each of the eight seventy-five pound samples and dried in an oven. The oven was constructed from a wooden box approximately three feet long, two and one-half feet wide and two feet deep. One end of the box was used for a door. The box was lined with asbestos one-eighth of an inch thick. The heat was provided by two 300-watt light bulbs mounted in the top of the box. The temperature was kept at 140 degrees F. with a thermostat. The samples were dried for forty-eight hours. They were then pulverized in a mortar using a medium hard rubber pestle.

Ten grams each of the dried samples were placed in test tubes and forty grams of distilled water added to each. After rubber stoppers were placed in the test tubes they were agitated by a shaking machine for two hours. The test tubes were then placed in an upright position and soil particles allowed to settle. After 24 hours the settling was complete and the liquid was siphoned off and given a hydrogen ion test.

A Becker model G pH meter with glass and cadmium electrodes was used. The results of the test are shown in table I.

The remainder of each sample was placed in the top sieve of a set of four sieves. The sieves were of the

following sizes: 14 mesh, 24 mesh, 66 mesh, and 126 mesh. With the set of sieves in a vertical position each sample was shaken laterally for two hours and the percentage passing each was determined. The results of the analysis are shown in table II.

TABLE I. HYDROGEN ION CONCENTRATION

Soil Type	pH
Boyd clay loam	7.18
Tripp silt loam	7.25
Rokeby silt clay loam	7.15
Colby silt loam	7.67
Crete silty clay	7.31
Hall silt loam	7.31
Hastings silty clay loam	7.34
Colby silt loam (red)	7.47

TABLE II. SCREEN ANALYSIS

Soil Type	Percentage Passing			
	14 mesh	24 mesh	66 mesh	126 mesh
Boyd clay loam	97	75	63	36
Tripp silt loam	95	91	74	51
Rokeby silt clay loam	96	81	70	68
Colby silt loam	99	96	88	76
Crete silty clay	100	91	67	53
Hall silt loam	100	97	79	64
Hastings silty clay loam	96	90	71	67
Colby silt loam (red)	96	79	56	42

## SELECTION OF SOIL MATERIAL WITH RESPECT TO SHRINKAGE

To determine the effect of the addition of sand to the samples a form three inches by five inches by one inch was constructed of one inch lumber and lined with light sheet metal. Samples of each soil were mixed with sufficient water to give a consistency a little less than that of putty. A large piece of sheet rock was used for a pouring surface. The pouring surface was covered with a thin layer of very fine sand to prevent the bricks from sticking to it when dried. The form was dipped in water and placed on the pouring surface. The soil-water mixtures were poured into the form and worked well into the corners. The excess was struck off the top with a straightedge. The form was then lifted from the brick.

A tin trough twelve inches long, eight inches wide and six inches deep was used for a mixing vessel. The soil and water was mixed with a putty knife. The amount of water varied from twenty to forty per cent by weight. After the bricks had dried over night they were set on edge to allow equal curing from both sides.

Sample bricks were poured from pure soil and from mixtures containing 90% soil and 10% sand, 80% soil and 20% sand, 70% soil and 30% sand, and 60% soil and 40% sand. The sand used was standard concrete sand screened

through a screen with a one-eighth inch mesh. A description of the sample bricks follows:

Crete silty clay

100% Crete silty clay

The cured bricks were very hard. All three of the samples developed surface cracks. The bricks did not break or crumble. The cracks were large but the samples remained in one piece.

90% Crete silty clay and 10% sand

The cured samples were hard and some warping was noticed. All of the samples broke.

80% Crete silty clay and 20% sand

The cured samples were very hard and some warping was noticed. Two of the three samples broke and the third cracked.

70% Crete silty clay and 30% sand

The cured sample bricks were very hard and none of the bricks broke. All three had medium cracks.

60% Crete silty clay and 40% sand

There were no cracks in the samples which were very hard. Warping was not noticeable and the texture was good.

Hastings silty clay loam

100% Hastings silty clay loam

A few small cracks were found in all of the three bricks. The bricks did not crumble but some warping was noticed.

90% Hastings silty clay loam and 10% sand

The cured samples were very hard with no cracks but some warping occurred.

80% Hastings silty clay loam and 20% sand

Two bricks had no cracks but the third one was cracked. The bricks were not very hard and no warping was noticed.

70% Hastings silty clay loam and 30% sand

There were no cracks and no warping occurred in the three samples. The texture of the bricks was good and they were hard.

60% Hastings silty clay loam and 40% sand

There were no cracks in the three bricks, the texture was sandy and the surface was easily rubbed off, the sample bricks having a tendency to crumble.

#### Boyd clay loam

100% Boyd clay loam

The cured bricks had large cracks, but were very hard. All of them had at least two cracks extending either along the length of the bricks or across them; never both ways.

90% Boyd clay loam and 10% sand

The cured bricks had large cracks, but the samples were very hard, though they all broke.

80% Boyd clay loam and 20% sand

The bricks showed small cracks and were not very hard, but none of the samples broke. All were badly warped.

70% Boyd clay loam and 30% sand

The cured bricks had no cracks, were very hard. The texture was good and they did not warp.

60% Boyd clay loam and 40% sand

The bricks had no cracks, but were soft and crumbled when rubbed.

#### Hall silt loam

100% Hall silt loam

The bricks cured very well, no cracks being found in any of the samples. The bricks had a good texture, but were not very hard.

90% Hall silt loam and 20% sand

There were no cracks in the three samples, but the texture was sandy and the bricks had a tendency to crumble.

A higher percentage of sand was not tried with Hall Silt Loam.

#### Rokeby silty clay loam

100% Rokeby silty clay loam

The bricks cured very well with no cracks or warping.

The samples were hard and did not crumble.

90% Rokeby silty clay loam and 10% sand

No cracks were found in the samples, but they were soft and crumbled when handled.

80% Rokeby silty clay loam and 20% sand

The bricks were very soft and crumbled very easily and the texture was very sandy. No cracks were found in the samples.

A higher percentage of sand was not tried with Rokeby silty clay loam.

#### Colby silt loam

100% Colby silt loam

The samples cured very well with no warping. There were no cracks in the samples and the texture was good.

90% Colby silt loam and 10% sand

The sample bricks cured well, no cracks were found and the bricks did not warp.

80% Colby silt loam and 20% sand

There were no cracks in the bricks, but they were soft and crumbled easily.

A higher percentage of sand was not tried with Colby silt loam.

#### Colby silt loam (red)

100% Colby silt loam (red)

The samples cured very hard, but two broke and the other developed a large crack.

90% Colby silt loam (red) and 10% sand

All three of the samples had medium cracks, but none of them broke.



80% Colby silt loam (red) and 20% sand

The cured bricks were hard, but some small cracks were found.

70% Colby silt loam (red) and 30% sand

The samples cured very hard and no cracks were present.

60% Colby silt loam (red) and 40% sand

No cracks were found in the samples, but they had a tendency to crumble and had a sandy texture.

Tripp silt loam

100% Tripp silt loam

The bricks cured very well and were hard with no cracks.

A higher percentage of sand was not tried with Tripp silt loam

When the sample bricks were cured they were measured and the percentage of shrinkage from their wet size was determined. The results are shown in the following graph:

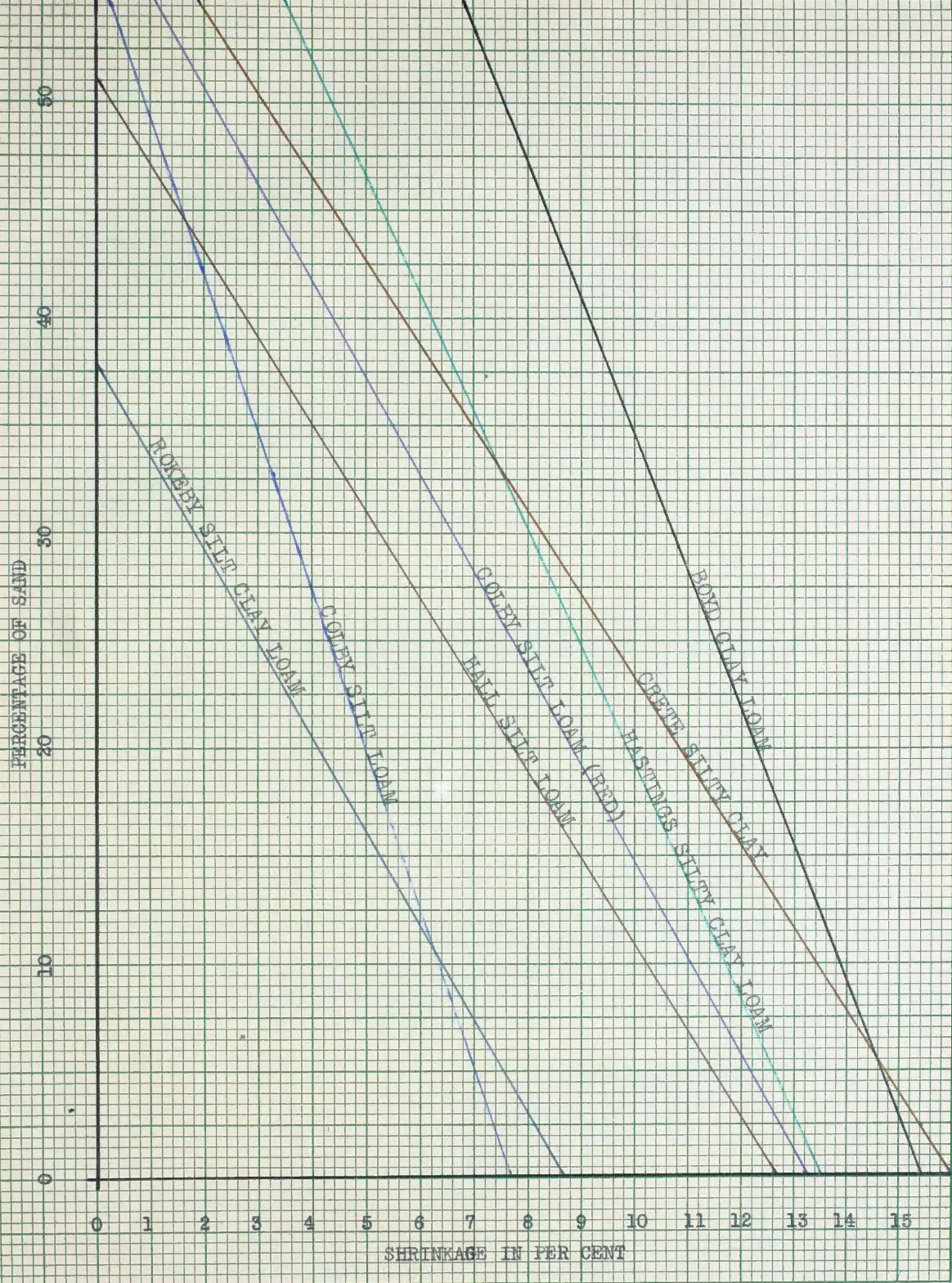

FIGURE I

THE EFFECT OF THE ADDITION OF SAND ON SHRINKAGE

To determine the sand soil mixtures for standard size bricks that would not crack the following work was done.

A form was constructed of one inch lumber and lined with light sheet metal. The inside dimensions were eighteen inches by twelve inches by four inches. This size was chosen because a brick of this size is the largest standard brick. If a brick this size could be made without excess shrinkage, which causes cracking, the smaller sizes and specially-shaped bricks could be made without shrinkage cracks.

A sixty-pound sample of dry soil was dampened with water. After letting the mixture stand until the clods were softened, more water was added and mixed until the mixture was smooth and contained no lumps or clods of dry soil. The amount of water added was such, that the mixture was easily worked into the corners of the form, but not so large an amount that the brick slumped out of shape when the form was immediately removed after the brick was poured. The form was first dipped in water and then placed on a pallet which had first been covered with a thin layer of sand to prevent the brick from sticking to it and to allow it to move as a whole as the brick dried. This not only prevented cracking because of sticking to the pallet, but made the brick much easier to remove from the pallet when dry.

The mixture was worked into the corners of the form with a trowel and the excess was struck off the top with a straightedge, then the form was removed. (In actual construction work, the upper and lower surfaces, that is the eighteen by twelve faces are sprinkled with sharp gravel to insure a good mortar bond.) The brick was then allowed to dry and cure. If the brick cracked upon drying, it was again mixed with water and sand was added. The sand had been screened through an 8-mesh screen. When the mixture was again smooth and contained no lumps of dry soil it was poured as before and allowed to cure. This process was repeated until a mixture was found that when formed into a brick would cure or dry with no cracks.

The sand was added by volume, the first sand-soil mixture was five parts of soil and one part of sand; if that proved unsatisfactory, five parts of soil to two parts of sand were tried. This process was continued until a sand-soil mixture for each of the eight samples was found that when mixed with water and formed into a brick would dry without cracking. The mixtures are listed in table III.

TABLE III

---

SAND SOIL MIXTURES NECESSARY FOR BRICKS THAT WILL  
NOT CRACK.

Soil Type	Parts of Sand	Parts of Soil
Crete silty clay	3	1
Hastings silty clay loam	7	3
Boyd clay loam	3	1
Hall silt loam	7	3
Colby silt loam	7	3
Colby silt loam (red)	7	3
Rokeby silt clay loam	2	1
Tripp silt loam	0	1

---

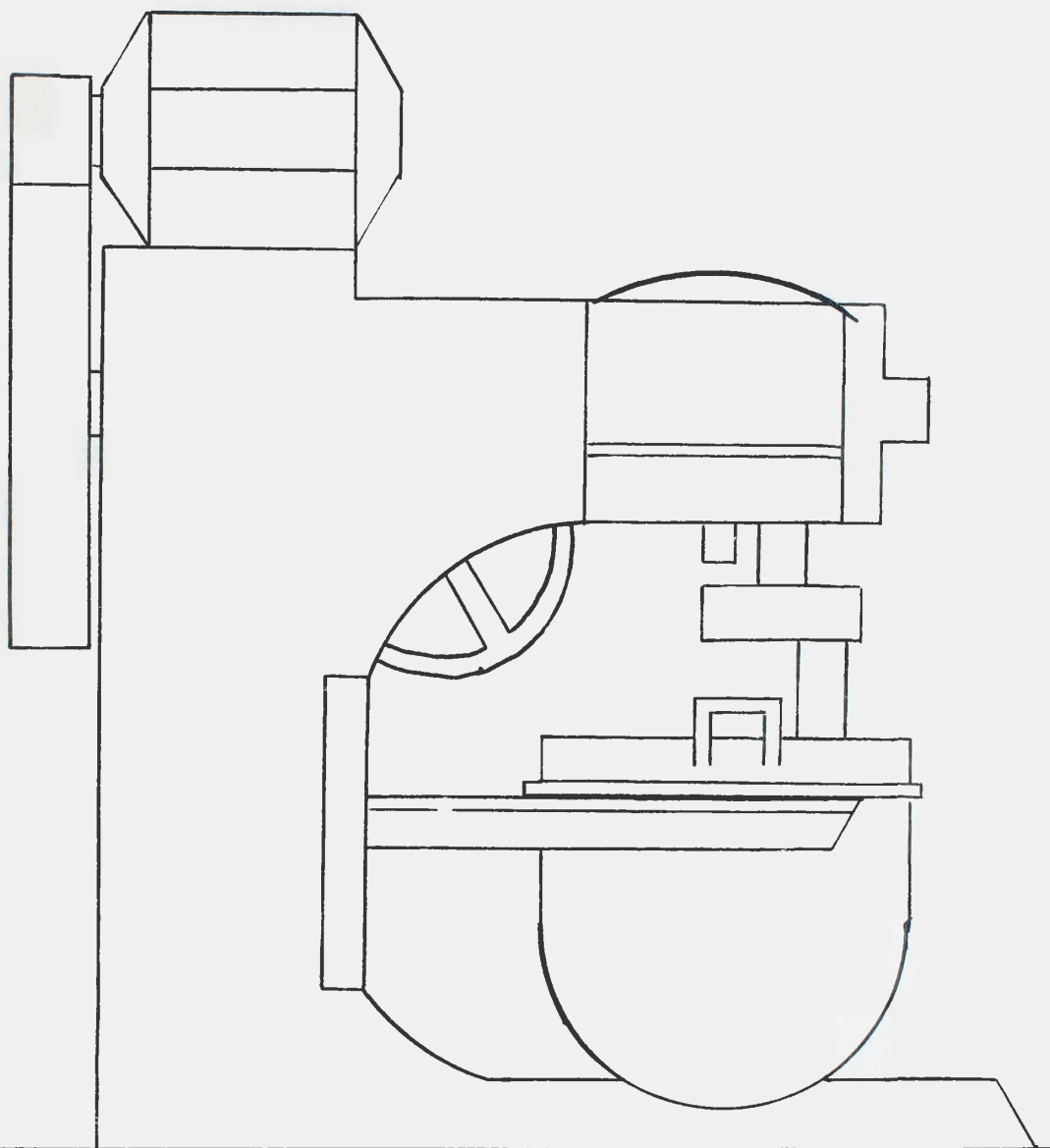

FIGURE 2  
A SKETCH OF THE MIXER USED TO  
MIX THE SIXTY-POUND SAMPLES OF SOIL.

## The Effects of Adding Straw

Straw added to soil samples and then molded into sample bricks produced bricks of a quality no better than those containing no straw. The amount of shrinkage was reduced very slightly. The surface of the bricks containing straw was rough and coarse while those containing no straw was smooth. The addition of straw to soils containing the proper mixture of sand and soil apparently had no beneficial effect.

## STABILIZERS

Substances that are added to the soil-water mixture to produce a water-resistant soil block are called stabilizers. Six stabilizers were tested:

- asphalt
- road oil
- reduced crude oil
- residium
- colas G-104
- bitudobe

The asphalt was of the type used as a roof coating. At room temperature it is a solid. The asphalt was heated until it was a liquid and kerosene was added. When the mixture cooled and the kerosene had evaporated the asphalt was in a very fine granular form. Asphalt in this form was tested.

The road oil was the type used in the surfacing of highways and was obtained from the Kansas State Highway Commission. It is a heavy black substance and is a liquid at room temperature.

Reduced crude oil was obtained at the Co-op Refinery located in Phillipsburg, Kansas. It is black in color, a liquid at room temperature and very heavy.

Colas G104 is a product manufactured by the Shell Oil Company for surfacing of highways. It is dark brown in color and has the consistency of water at room temperature.

The residium was also obtained at the Co-op Refinery



and is a heavy black liquid at room temperature.

The bitudobe was purchased from the American Bit-  
umuls Company. It is dark brown in color and has the  
consistency of water. Bitudobe is a product manufactured  
especially for stabilizing soil blocks.

Three of the stabilizers were discarded after pre-  
liminary tests which consisted of the following:

Sample bricks three inches by five inches by one inch  
were poured. All of these samples were made from Tripp  
silt loam. Sample bricks were made containing 10% by  
weight of each of the six stabilizers. All of the bricks  
when cured were hard. The samples were dipped in water  
and removed. Drops of water stood on the surfaces of all  
the sample bricks except the one containing asphalt.  
The sample containing the asphalt absorbed the water so  
asphalt was discarded.

The remaining samples were then placed on edge on  
a wet sponge. At the end of 12 hours the sample bricks  
were inspected. The sample bricks containing road oil  
and reduced crude oil developed very small cracks along  
the surface that was in contact with the sponge. When  
that surface was touched with the finger it crumbled  
away. Reduced crude oil and the road oil were discarded  
leaving residium, colas and bitudobe for more extensive  
tests.

## WATER ABSORPTION TESTS

Sample bricks, one and one-half inch cubes, were made to be used for the water absorption tests. The sand soil mixtures as given in table III were used. Three different amounts of each of the three stabilizers were used:

1. One pound of stabilizer to fifty pounds of sand and soil.
2. Two pounds of stabilizer to fifty pounds of sand and soil.
3. Three pounds of stabilizer to fifty pounds of sand and soil.

Proper amounts of sand and soil were mixed dry. Then water was added and lastly the correct amount of stabilizer for the specific sample was added. The mixture was worked until its color was uniform. A form, three inches by five inches by one inch, was dipped in water and placed on a sand-covered level surface. The mixture poured in, worked well into the corners and the top struck off smooth. The form was then removed. After the sample brick had stood for an hour a one-inch cube was cut from the corner with a knife which had first been dipped in water. The cubes were allowed to stand for 24 hours. At the end of that time the rough edges of the cubes were squared with a knife. This was

easily done because the sample bricks were not yet thoroughly dry. They were just dry enough to handle. They were allowed to cure for a week. At the end of that time they were placed in an oven kept at 140 degrees F. until they attained a constant weight, which was recorded as the dry weight. The samples were placed upon a rectangular sponge one inch thick. The sponge with the sample bricks was placed in a pan three-fourths of an inch deep. A battery-jar was placed upside down over the sponge and the pan was filled with water. The lip of the battery-jar was kept under the surface of the water at all times. The jar and pan thus formed a moist cabinet. The battery-jar did not fit the bottom of the pan so tightly as to prevent the water from seeping under the jar as it was being absorbed by the sponge.

After seven days the sample bricks were weighed and the increase in weight from absorbed water determined.

The results are given in table IV. The graphs, Figs. 4-11, show the relation between the amount of stabilizer and the percentage increase in weight. The percentage increase in weight for mixtures containing more than three pounds of stabilizer per fifty pounds of soil were extrapolated.

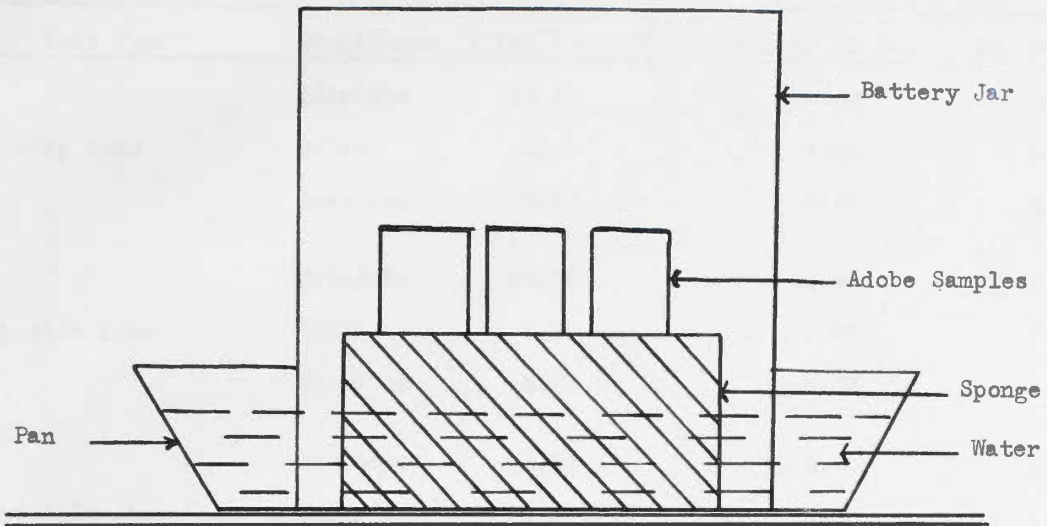

WATER ABSORPTION TEST APPARATUS



PHOTOGRAPH OF WATER ABSORPTION APPARATUS

FIGURE 3. WATER ABSORPTION APPARATUS.

TABLE IV

THE PERCENTAGE INCREASE IN WEIGHT IN ABSORPTION TESTS

Soil Type	Stabilizer	1 lb. to 50 lb.	2 lb. to 50 lb.	3 lb. to 50 lb.
Oyd clay loam	Bitudobe	14.70	13.50	5.82
	Colas	4.95	3.32	2.38
	Residium	3.38	3.24	2.39
Cripp silt loam	Bitudobe	24.00	11.40	5.97
	Colas	6.95	5.65	5.25
	Residium	3.11	2.28	1.70
Okeby silt clay loam	Bitudobe	6.80	2.20	1.97
	Colas	3.39	2.20	1.55
	Residium	1.38	1.90	1.54
Oolby silt loam	Bitudobe	13.40	8.21	3.92
	Colas	4.38	2.51	2.15
	Residium	4.08	2.40	2.21
Orete silty clay	Bitudobe	9.90	5.23	3.80
	Colas	4.45	3.35	2.80
	Residium	3.28	2.97	2.26
Oall silt loam	Bitudobe	10.50	4.05	2.58
	Colas	3.99	5.35	3.23
	Residium	1.83	1.22	1.05
Oastings silty clay loam	Bitudobe	9.30	6.41	3.72
	Colas	4.60	3.88	2.08
	Residium	2.84	1.92	1.42
Oolby silt loam (red)	Bitudobe	10.30	10.20	2.94
	Colas	9.50	5.60	1.83
	Residium	5.00	3.29	1.28

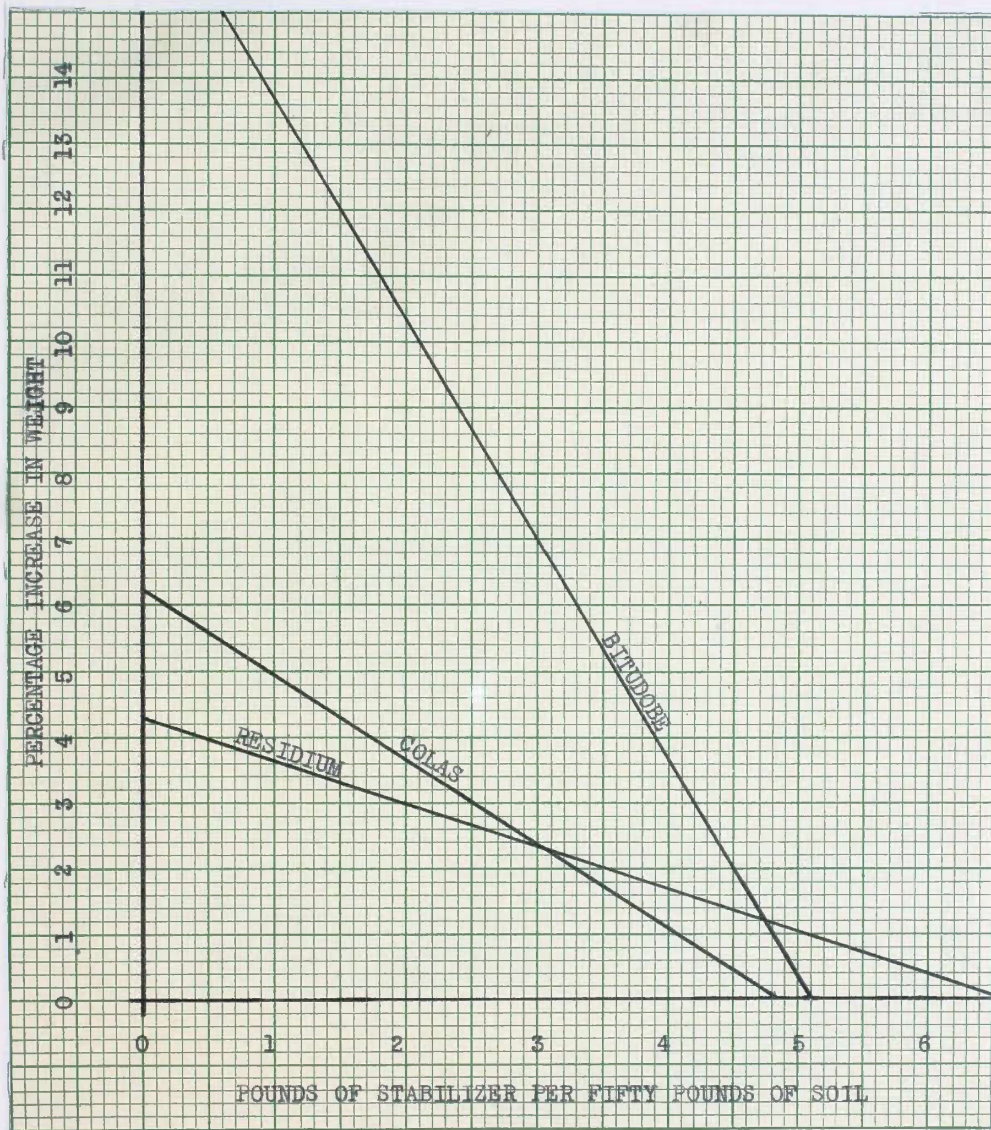

FIGURE 4  
BOYD CLAY LOAM

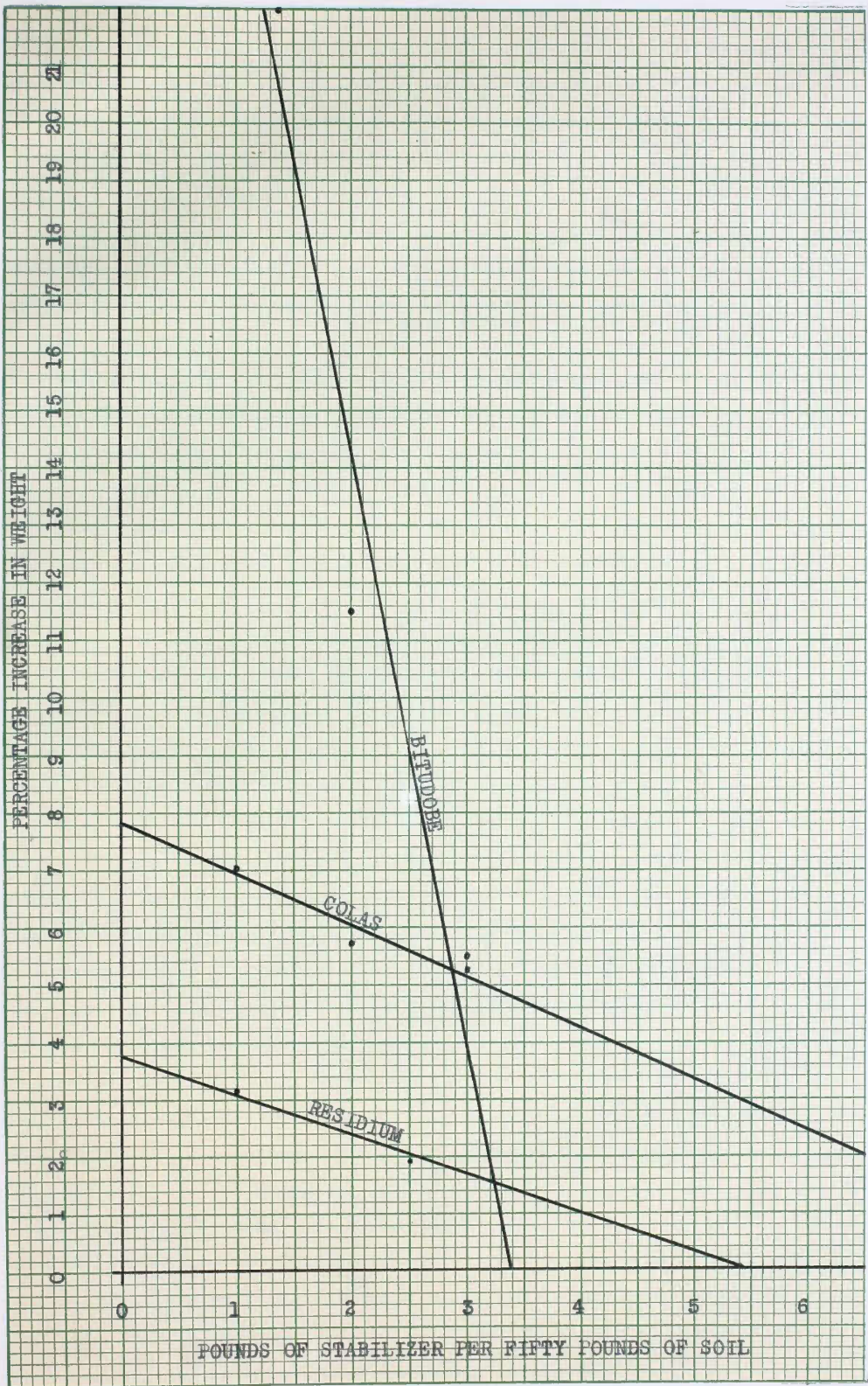

FIGURE 5

TRIPP SILT LOAM

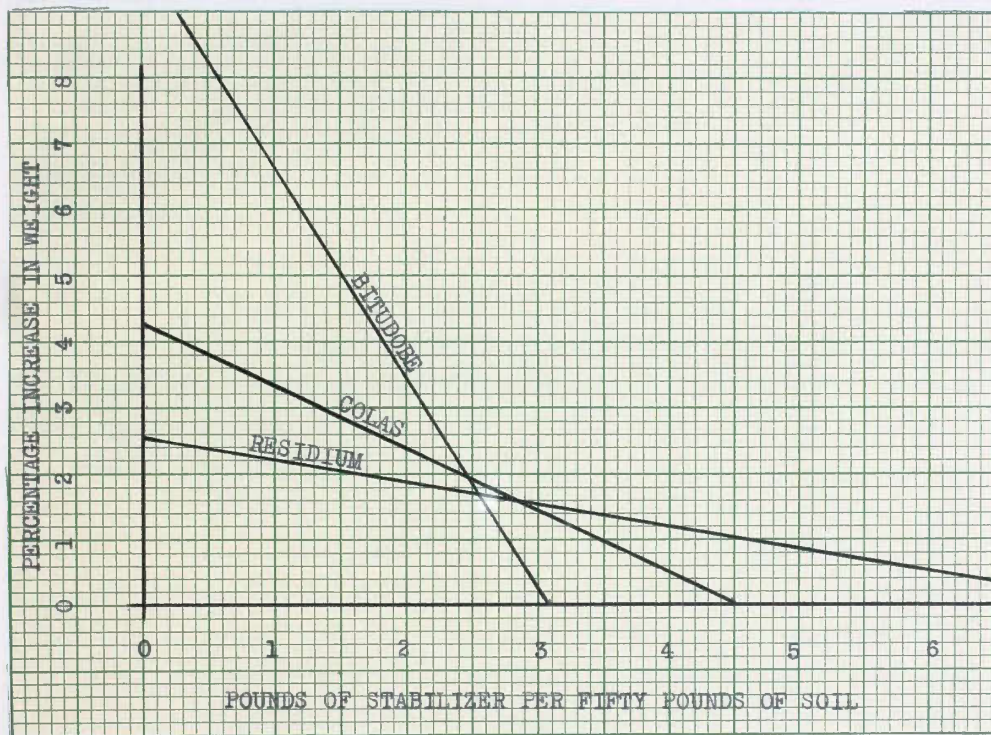

FIGURE 6  
ROKEBY SILT CLAY LOAM



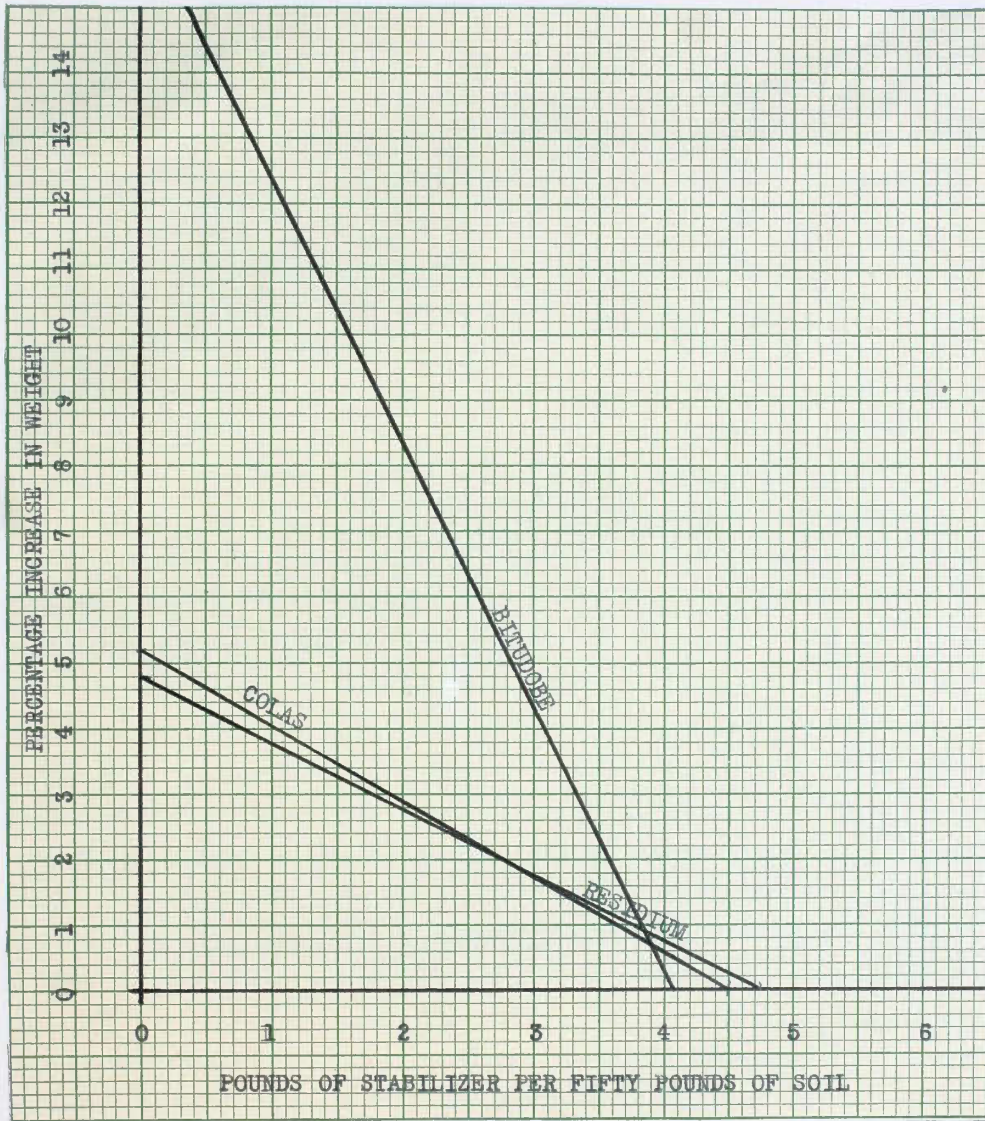

FIGURE 7  
COLBY SILT LOAM

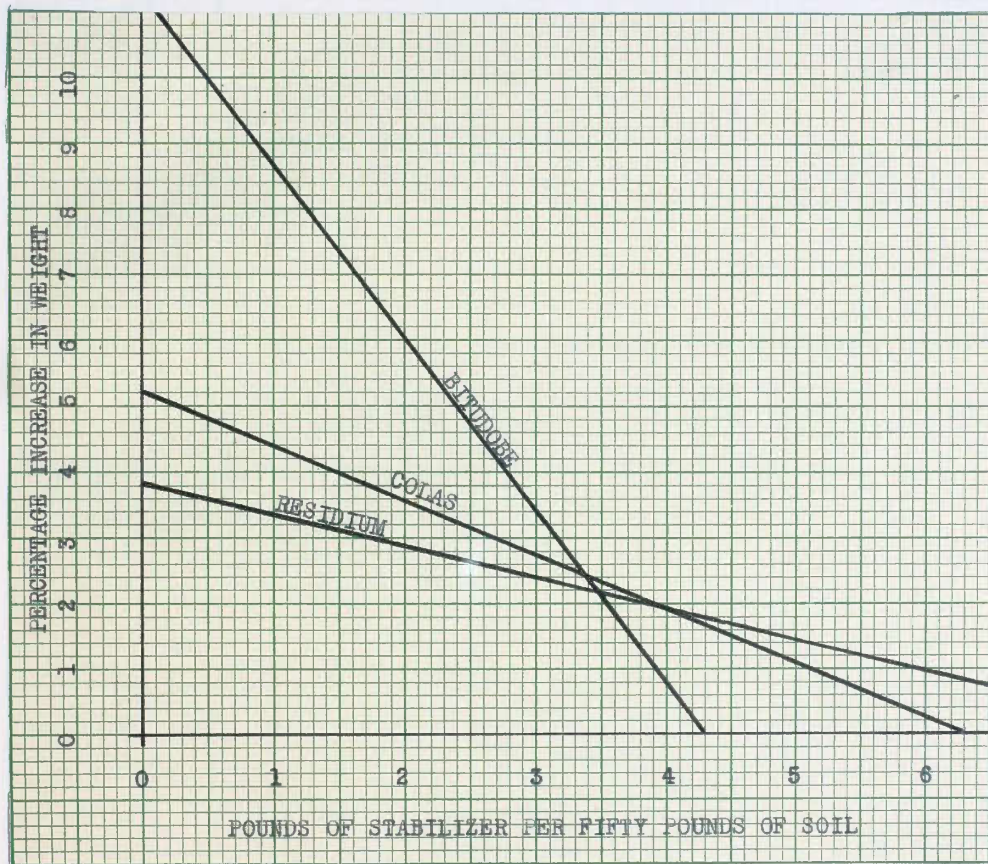

FIGURE 8  
CRETE SILTY CLAY

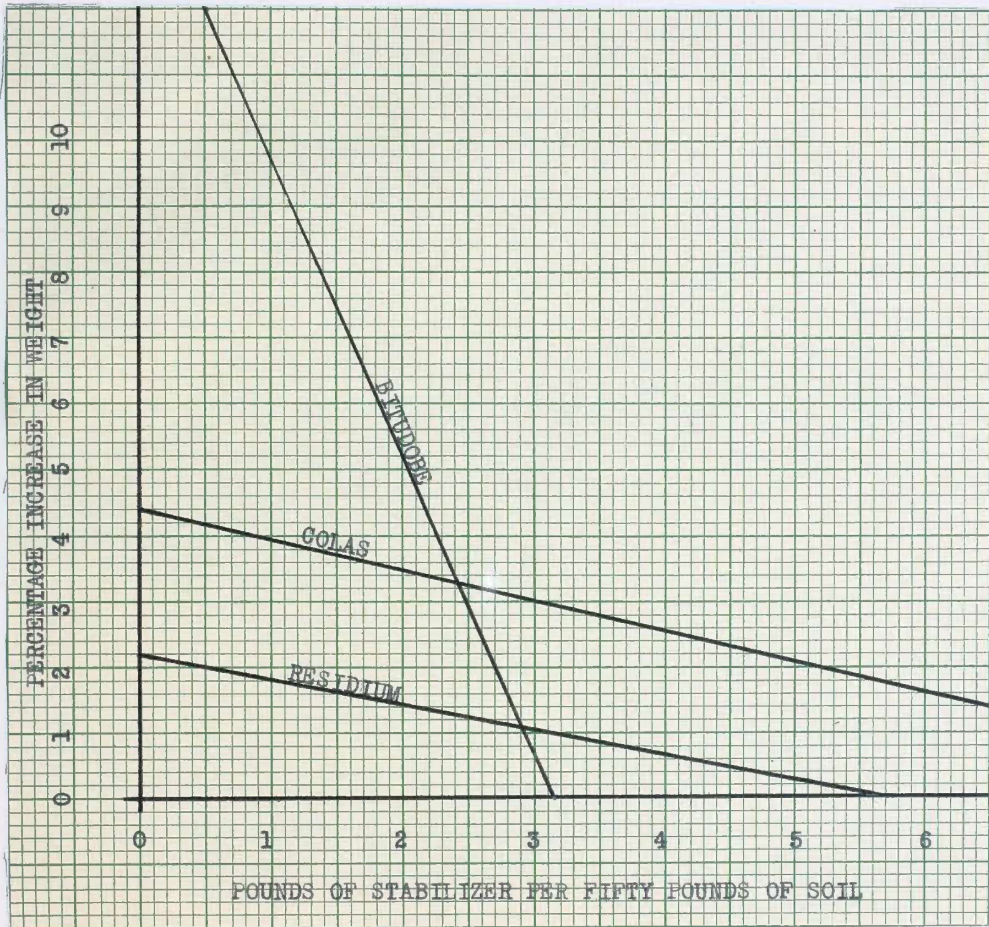

FIGURE 9  
HALF SILT LOAM

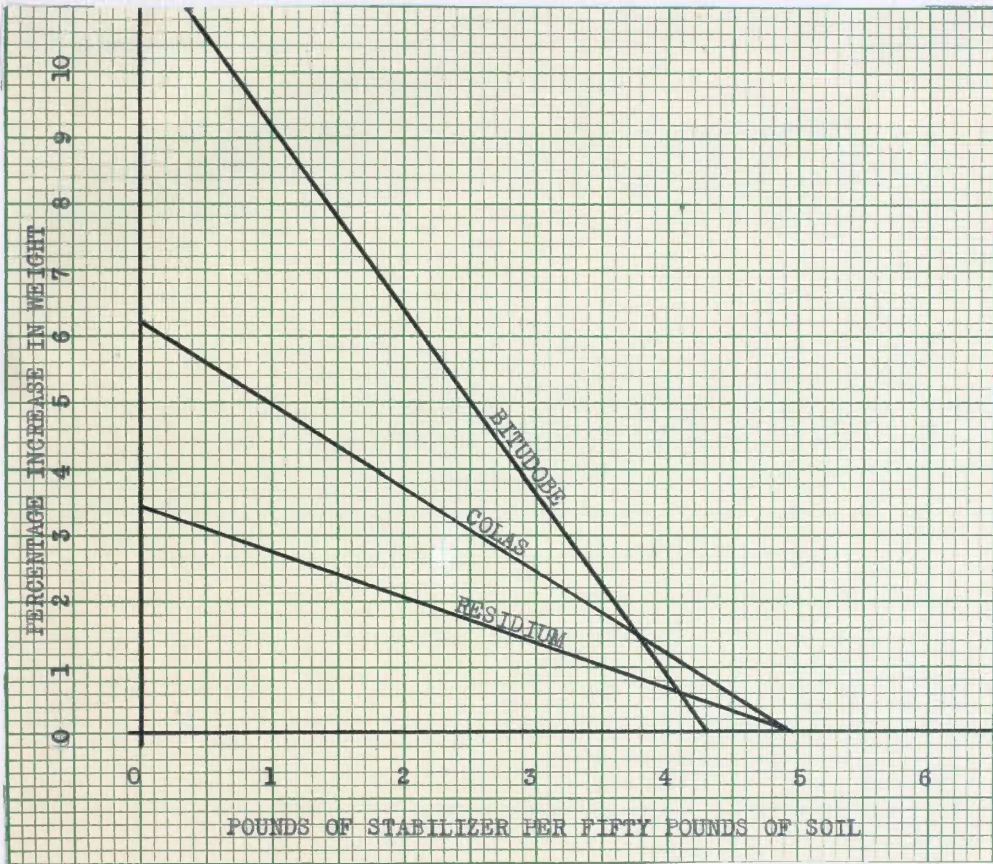

FIGURE 10  
HASTINGS SILTY CLAY LOAM

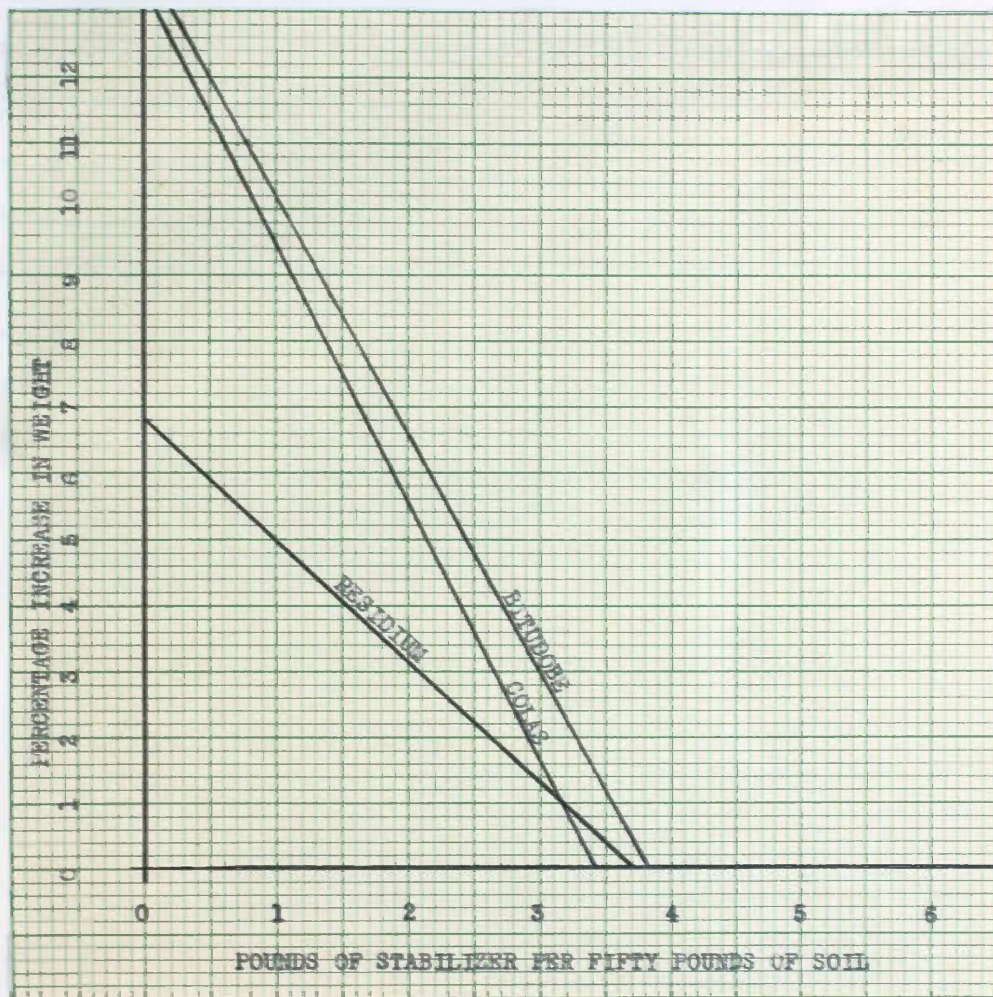

FIGURE 11

COLBY SILT LOAM (RED)

## PREPARATION FOR EROSION TESTS

A form four by three by one inch was constructed and lined with light sheet metal. The bricks were molded on a piece of sheet-rock sprinkled with fine sand. The mixtures of sand and soil given table III were first mixed in a dry state. Water was then added until the mixture had the correct consistency. Lastly the stabilizers were added and the components mixed until the batch had a uniform color. The color was produced by the stabilizers, colas and bitudobe yielding brown, and residium giving black.

Three amounts of stabilizers were tried as follows:

1. One pound of stabilizer to fifty pounds of sand and soil.
2. Two pounds of stabilizer to fifty pounds of sand and soil.
3. Three pounds of stabilizer to fifty pounds of sand and soil.

Thus for each type of soil nine separate mixtures were tested, that is, three of each stabilizer.

The sample bricks were poured on the sand-covered surface and the mold removed immediately. After 48 hours the bricks were placed on edge to hasten the curing. Two bricks of each mixture were made, 144 bricks in all.

After the sample bricks had cured for approximately

a week they were placed in an oven and kept at 140 degrees F. until each brick had a constant weight, assuring that the bricks were completely dry. The bricks were then piled in a dry place until given the test for erosion.

#### EROSION TESTS

The erosion tests consisted of the following: dry sample bricks were placed on edge and sprayed with water from a 2 inch shower head. The pressure of the water was 10 pounds. The distance of the shower head from the bricks was seven inches. The time for spraying varied from three minutes to a maximum time of two hours. (The apparatus is shown in Fig. 12.) If a brick became eroded within the time limit, the time was noted and the brick removed from the spray. A number of samples showed no erosion after two hours of continuous spraying. The results of the tests are given in table V.

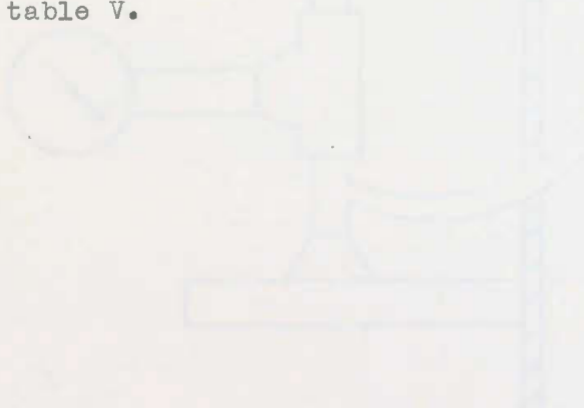

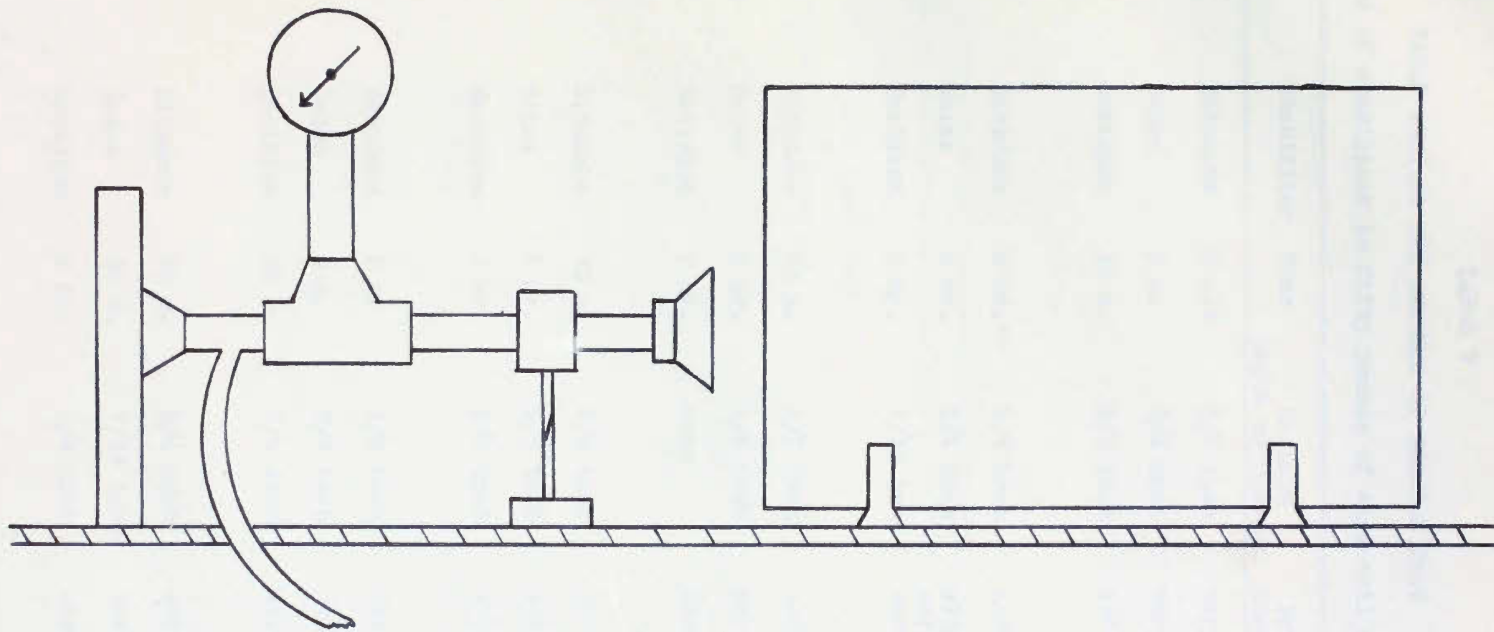

Figure 12. APPARATUS FOR EROSION TEST



TABLE V

## TABLE SHOWING THE RESULTS OF EROSION TEST

(One pound of stabilizer to fifty pounds of sand-soil mixture)

Soil Type	Stabilizer	Time	Maximum Depth of Erosion	Brick Condition	Extent of Erosion
d clay loam	Bitudobe	3 m.*	3/4 inch	very soft	very great
	Colas	5 m.	3/4 inch	very soft	very great
	Residium	10 m.	1/2 inch	soft	medium
pp silt loam	Bitudobe	2 hr.**	3/4 inch	soft	very great
	Colas	2 hr.	1/4 inch	slightly soft	slight
	Residium	2 hr.	1/32 inch	hard	very slight
reby silt clay loam	Bitudobe	35 m.	3/8 inch	soft	medium
	Colas	2 hr.	1/8 inch	hard	slight
	Residium	2 hr.	none	hard	none
lby silt loam	Bitudobe	25 m.	3/4 inch	very soft	very great
	Colas	2 hr.	3/8 inch	soft	medium
	Residium	2 hr.	3/8 inch	soft	medium
ete silty clay	Bitudobe	3 m.	1/2 inch	Very soft	great
	Colas	5 m.	3/4 inch	soft	great
	Residium	34 m.	3/4 inch	soft	great
ll silt loam	Bitudobe	30 m.	3/4 inch	soft	very great
	Colas	30 m.	7/16 inch	soft	great
	Residium	2 hr.	1/4 inch	hard	slight

minute

hour

Soil Type	Stabilizer	Time	Maximum Depth of Erosion	Brick Condition	Extent of Erosion
tings silty clay loam	Bitudobe	15 m.	5/8 inch	soft	medium
	Colas	15 m.	5/16 inch	soft	medium
	Residium	70 m.	5/16 inch	soft	medium
oy silt loam (red)	Bitudobe	17 m.	3/4 inch	soft	very great
	Colas	15 m.	1/2 inch	soft	great
	Residium	25 m.	5/8 inch	soft	medium

(Two pounds of stabilizer to fifty pounds of sand-soil mixture)

Soil Type	Stabilizer	Time	Maximum Depth of Erosion	Brick Condition	Extent of Erosion
d clay loam	Bitudobe	5 m.	1/2 inch	soft	great
	Colas	30 m.	3/4 inch	very soft	very great
	Residium	30 m.	1/2 inch	soft	medium
pp silt loam	Bitudobe	2 hr.	1/4 inch	slightly soft	medium
	Colas	2 hr.	1/8 inch	hard	very slight
	Residium	1 hr.	none	very hard	none
eby silt clay loam	Bitudobe	2 hr.	none	very hard	none
	Colas	2 hr.	none	very hard	none
	Residium	2 hr.	none	very hard	none
by silt loam	Bitudobe	1 hr.	1/4 inch	slightly soft	medium
	Colas	2 hr.	1/16 inch	hard	very slight
	Residium	2 hr.	none	hard	none

Soil Type	Stabilizer	Time	Maximum Depth of Erosion	Brick Condition	Extent of Erosion
silty clay	Bitudobe	16 m.	3/8 inch	soft	medium
	Colas	1 hr.	3/8 inch	soft	medium
	Residium	1 1/2 hr.	1/4 inch	soft	medium
silt loam	Bitudobe	2 hr.	3/8 inch	soft	medium
	Colas	2 hr.	1/4 inch	hard	slight
	Residium	2 hr.	none	hard	none
ings silty clay loam	Bitudobe	1 1/4 hr.	7/16 inch	soft	medium
	Colas	2 hr.	1/8 inch	hard	slight
	Residium	2 hr.	1/8 inch	hard	slight
y silt loam (red)	Bitudobe	17 m.	3/8 inch	soft	medium
	Colas	2 hr.	1/2 inch	soft	great
	Residium	2 hr.	1/8 inch	slightly soft	slight

(Three pounds of stabilizer to fifty pounds of sand-soil mixture)

Soil Type	Stabilizer	Time	Maximum Depth of Erosion	Brick Condition	Extent of Erosion
clay loam	Bitudobe	5 m.	3/8 inch	slightly soft	medium
	Colas	1 hr.	1/2 inch	slightly soft	medium
	Residium	2 hr.	3/8 inch	slightly soft	medium
p silt loam	Bitudobe	2 hr.	none	very hard	none
	Colas	2 hr.	1/16	very hard	very very slight
	Residium	2 hr.	none	very hard	none

Soil Type	Stabilizer	Time	Maximum Depth of Erosion	Brick Condition	Extent of Erosion
by silt clay loam	Bitudobe	2 hr.	none	very hard	none
	Colas	2 hr.	none	very hard	none
	Residium	2 hr.	none	very hard	none
y silt loam	Bitudobe	2 hr.	none	hard	very very slight
	Colas	2 hr.	none	very hard	none
	Residium	2 hr.	none	very hard	none
e silty clay	Bitudobe	16 m.	1/4 inch	soft	medium
	Colas	1 hr.	3/16 inch	hard	slight
	Residium	2 hr.	none	hard	very slight
silt loam	Bitudobe	2 hr.	none	hard	very slight
	Colas	2 hr.	none	very hard	none
	Residium	2 hr.	none	very hard	none
ings silty clay loam	Bitudobe	1 1/4 hr.	1/8 inch	hard	slight
	Colas	2 hr.	none	hard	very slight
	Residium	2 hr.	none	very hard	none
y silt loam (red)	Bitudobe	2 hr.	1/4 inch	soft	medium
	Colas	2 hr.	1/16 inch	hard	very slight
	Residium	2 hr.	none	very hard	none

## PAINTING

A set of bricks the same size and having the same proportions of stabilizer as those used in the erosion tests was poured. The bricks were dried to constant weight. One-third of each sample brick was painted with aluminum paint, one-third was not painted and the other one-third was painted with asphalt base aluminum paint. The paint was allowed to dry for 48 hours. Then one-half of each of the three areas was given a coat of outside white house paint. After 48 hours a second coat of the white paint was given these surfaces. The paint was then allowed to dry for one week.

The aluminum paint used was Aluminum Du Pont Duco, made by E.I. Du Pont De Nemours and Co., Inc., Wilmington, Delaware. The asphalt-base aluminum used was Mayfair Asphalt Aluminum, Paint #2971 made by the Waggener Paint Company, Kansas City, Mo. The outside house paint used was Pittsburgh Sun-Proof House Paint, 1-54v titanic outside white.

At the end of the drying period the paint was hard. All three of the strips given the two coats of white house paint were equally white. The bricks were laid flat and sprinkled with water. The amount of water was great enough to allow water to stand on the surface of the bricks. The temperature of the bricks was 70 degrees F. The samples

were then placed out-of-doors on a table, being careful not to spill the water from the surface of the bricks. Snow was falling and the temperature was 20 degrees F. The samples were left out doors for 48 hours. The lowest temperature during that period was -23 degrees F. Owing to the location of the table, the sun of the following day, was warm enough to melt the snow that had fallen on the samples. That night the temperature dropped to 15 degrees F. freezing the water and bricks again. The following morning the samples were moved indoors where the temperature was 80 degrees F. The samples experienced a 103 degree change in temperature and were frozen twice. Upon careful examination no deterioration of exposed brick surface or of the painted surfaces was found.

The stabilizers did not show through the two coats of white paint on the bare brick, nor did they show after a period of 30 days. Using the Du Pont Aluminum or the Mayfair Asphalt Base Aluminum as a prime coat made covering with white much easier. One coat of aluminum completely covered the black color of the samples made from soils stabilized with residium.

## CONCLUSION

The soils of Ellis County are in general suitable for use in making adobe bricks. All but one of the eight samples had to be blended with sand to prevent cracking. The amount of sand that had to be added could not be determined from the simple screen analysis nor from the hydrogen ion concentration. Pouring sample bricks with varying percentages of sand is the most dependable method of finding the admixture of sand necessary.

The requirements of the Federal Housing Administration for adobe brick construction is that the bricks be rendered water-resistant (Long, 5).

For a brick to be considered water-resistant the American Bitumuls Company requires that it absorb not more than 2.5% moisture by weight when exposed to a wet surface for seven days and should not be appreciably pitted or eroded in two hours of spraying with a fine spray (American Bitumuls Co., 1). It appears that all of the samples tested could be made to meet those requirements if a sufficient amount of stabilizer is used. The amount of residium needed to meet these requirements was less than that required of colas or bitudobe. In most cases less colas was required than bitudobe.

A prime coat of asphalt aluminum paint forms a very fine base for painting. The asphalt paint is also a

water-proofing substance. The paint was applied with a brush. A better and more complete covering of the rough surface could have been made by spraying the paint on the surface. The tests given the painted surfaces were limited. To reproduce the climatic conditions of Ellis County for a span of five years was beyond the scope of the experimental work. From the tests given it appears that the surfaces will "take" paint and that the paint will retain its original color.



## BIBLIOGRAPHY

1. American Bitumuls Company, Test for Bitudobe Stabilized Soil Bricks and Hydropel Treated Cement Mortar. Oakland, 1947. 2pp. (Technical Paper No. 39)  
Contains requirements for bricks and methods of testing.
2. Bass, N.W., Geologic Investigations in Western Kansas. Topeka: State Printing Office, 1926. (Bulletin No. 11, State Geological Survey on Kansas. Part I Geology of Ellis County, p. 1-25).  
A general investigation of the geological history of western Kansas.
3. Frye, John C., and James J. Brazil, Ground Water in the Oil-Field Areas of Ellis and Russell Counties, Kansas. Topeka: Kansas State Printing Plant, 1943. 104pp. (University of Kansas Publications, State Geological Survey of Kansas, Bulletin No. 50, 1943.)  
Discussion of the geological formations in relation to the ground water in the oil-field areas.
4. Frye, J.C., John M. Jewitt, and Walter H. Schoewe, Resource-Full Kansas. Lawrence: University of Kansas Press, [1947?] (State Geological Survey of Kansas.) 48pp.  
A discussion of the geological aspects of Kansas.

5. Long, J.G., Adobe Construction. Revised by L.W. Neubauer, November 1946; Berkely: University of California, 1946. 66pp. (California Agricultural Experiment Station.)  
Discussion of different types of earth construction.
6. Twenhofel, W.H., Treatise on Sedimentation. 2nd. Ed., Completely Revised; Baltimore: The Williams and Wilkins, 1932. 926pp.  
Deals with the sources, production, and transportation of sediments.