

Rowan University

Rowan Digital Works

---

Theses and Dissertations

---

6-11-2015

## Minimizing average handling time in contact centers by introducing a new process: Rowan Support Desk case study

Niusha Jafari

Follow this and additional works at: <https://rdw.rowan.edu/etd>



Part of the Operations Research, Systems Engineering and Industrial Engineering Commons

Let us know how access to this document benefits you - share your thoughts on our feedback form.

---

### Recommended Citation

Jafari, Niusha, "Minimizing average handling time in contact centers by introducing a new process: Rowan Support Desk case study" (2015). *Theses and Dissertations*. 499.

<https://rdw.rowan.edu/etd/499>

This Thesis is brought to you for free and open access by Rowan Digital Works. It has been accepted for inclusion in Theses and Dissertations by an authorized administrator of Rowan Digital Works. For more information, please contact [LibraryTheses@rowan.edu](mailto:LibraryTheses@rowan.edu).

**MINIMIZING AVERAGE HANDLING TIME IN CONTACT CENTERS  
BY INTRODUCING A NEW PROCESS:  
ROWAN SUPPORT DESK CASE STUDY**

by

Niusha Jafari

A Thesis

Submitted to the  
Department of Civil Engineering  
College of Engineering  
In partial fulfillment of the requirement  
For the degree of  
Master of Science in Engineering Management  
at  
Rowan University  
May 2015

Thesis Chair: Mira Lalovic-Hand, Ph.D.

© 2015

Niusha Jafari

## **Dedications**

*I would like to dedicate this thesis to*

*My beloved husband, Arash, who was the inspiration of starting this journey and with the comfort of having him at my beside, troubles have never bothered me and worries can never scared me.*

*My loving parents, Mahnaz and Kouros, whose magic of words and endless encouragement never let me down. None of my achievements would have been possible without their unconditional supports and love.*

*My sweet sisters, Elnaz and Ghazaleh, who are my angels and I've missed so many days and nights talking, laughing and crying with them.*

*Success is always mine, because I have all of you by my side.*

## **Acknowledgments**

I would like to express my deepest gratitude and warmest affection to my advisor, Dr. Mira Lalovic-Hand, who has been constant source of motivation. Thank you for all your support, guidance, and patience along the way.

I am thoroughly grateful to the kindest teacher I've ever had, Daphne TeeGarden, who spent so many hours reading my work and improving my English.

I would also thank Rowan support desk manger and staff for warmly helping me and sharing data with me.

In addition, I would like to thank Dr. Ralph Dusseau for being so prompt in answering my question and his dedication to students.

## **Abstract**

Niusha Jafari  
MINIMIZING AVERAGE HANDLING TIME IN CONTACT CENTERS  
BY INTRODUCING A NEW PROCESS:  
ROWAN SUPPORT DESK CASE STUDY  
2015/2016  
Mira lalovic-Hand, Ph.D.  
Master of Science in Engineering Management

Quality of a call center performance is an important factor in insuring customer satisfaction. Customers, the “callers”, want their requests solved quickly, permanently and to their satisfaction. Often, there are staff constraints, budget or cost limitation, and the Service Level Agreement (SLA) which is resource availability to accomplish a task within a deadline. The purpose of this research is to analyze feasible approaches to minimize the long-lasting open requests and enhance a call center’s performance. Multiple challenges that a call center often faces in handling requests are studied to identify key bottlenecks in the process of handling requests. Rowan University support desk is used as a case study. The focus of this study is on over-extended unsolved requests under set of specific constraints.

The following two alternative solutions were investigated and compared. One involves reorganizing the routing procedure, which would allow a ticket to be rerouted to the specialists. The other scenario investigates an increase in staff and efficiencies that would come with it. The research will show that with minimal effort in rerouting the unsolved tickets, we can decrease average handling time which simultaneously increases the total number of resolved tickets and minimize total processing time.

## Table of Contents

|   |    |
|---|----|
| Abstract .....  | v  |
| List of Figures .....   | ix |
| List of Tables .....  | x  |
| Chapter 1: Introduction .....                                     | 1  |
| 1.1. Importance .....   | 1  |
| 1.2. Problem Statement .....                                      | 4  |
| 1.3. Scope of the Study .....                                     | 5  |
| 1.4. Research Objectives.....                                     | 5  |
| Chapter 2: Literature Review .....                                | 6  |
| 2.1. Contact Center Businesses .....                              | 6  |
| 2.2. Contact Center Models .....                                  | 13 |
| 2.3. Contact Center Services .....                                | 14 |
| 2.4. Contact Center Structure .....                               | 15 |
| 2.5. Contact Centers Key Performance Indicators .....             | 15 |
| 2.6. Routing and Prioritization Problems in Contact Centers ..... | 17 |
| 2.7. Analytical Models of Contact Centers .....                   | 19 |
| 2.7.1. Erlang-B Formula .....                                     | 19 |
| 2.7.2. Erlang-C Formula .....                                     | 20 |
| 2.7.3. Erlang-A Formula .....                                     | 20 |

**Table of Contents (Continued)**

2.8. Key Requirements of Contact Center Success ..... 21

Chapter 3: Research Methodology..... 25

3.1. Qualitative Research: Methodology..... 25

3.2. Sample Design ..... 26

3.3. Questionnaire Design..... 26

3.4. Quantitative Research: Data Collection Process..... 27

3.5. Quantitative Data Sample ..... 27

3.6. Limitations and Assumptions ..... 28

    3.6.1. Research Limitations ..... 28

    3.6.2. Project Constraints ..... 29

    3.6.3. Research Assumptions ..... 30

Chapter 4: Data Analysis ..... 31

4.1. Analysis of Survey and Interview Responses ..... 31

4.2. Quantitative Data Analysis and Findings..... 32

Chapter 5: Support Desk Performance Model Description..... 33

5.1. Model Explanation..... 33

5.2. Agent Performance ..... 33

5.3. Request Arrival Process ..... 37

5.4. Schematic Routing Diagram ..... 40



**Table of Contents (Continued)**

5.4.1. Current Process ..... 40

Chapter 6: Simulation ..... 43

6.1. Implementation ..... 43

6.2. The Simulation Model ..... 43

6.3. Simulation Runs ..... 45

6.4. Some Specific Design Issues ..... 54

Chapter 7: Results and Conclusion ..... 55

7.1. Results ..... 55

7.2. Recommended Considerations ..... 58

7.3. Conclusion ..... 59

7.4. Future Research ..... 61

References ..... 63

Appendix A: Definition of Terms ..... 66

Appendix B: Created Models in Arena Software ..... 68

## List of Figures

| Figure  | Page |
|---|------|
| Figure 1: Number of tickets (Academic year 2012-2013) .....                       | 28   |
| Figure 2: Cost Factor Ranking in a General Call Center .....                      | 30   |
| Figure 3: Agents' Performance Analysis.....                                       | 32   |
| Figure 4: Talk Time Frequency .....   | 35   |
| Figure 5: CDF Comparison of Intervals' Fitted Distribution .....                  | 38   |
| Figure 6: Intervals Schedule .....  | 39   |
| Figure 7: Current Request Handling Process Diagram .....                          | 41   |
| Figure 8: New Process for Handling Requests Diagram .....                         | 42   |
| Figure 9: Arena Module (Call Arrival) .....                                       | 46   |
| Figure 10: Arena Module (Other requests Arrival) .....                            | 46   |
| Figure 11: Arena Module (Priority Assignment) .....                               | 47   |
| Figure 12: Arena Module (Trunk Line Availability) .....                           | 47   |
| Figure 13: Arena Module (Call Handling Process) .....                             | 48   |
| Figure 14: Arena Module (Call Abandonment) .....                                  | 49   |
| Figure 15: Arena Module (Standard Handling Time Assignment).....                  | 50   |
| Figure 16: Arena Module (Call Routing Decision Box) .....                         | 50   |
| Figure 17: Arena Module (Specialists Group Handling Time Assignment).....         | 51   |
| Figure 18: Arena Module (Generalist Group Handling Time Assignment) .....         | 52   |
| Figure 19: Arena Module (Long Handling Time Checking) .....                       | 52   |
| Figure 20: Arena Module (Tickets Reassignment Process).....                       | 53   |
| Figure 21: Proposed Process Performance Analysis; AHT .....                       | 56   |
| Figure 22: Proposed Process Performance Analysis; Percent of Solved Tickets ..... | 56   |

## List of Tables

| Table   | Page |
|---|------|
| Table 1: Number of Tickets per Different Contact Channels ..... | 27   |
| Table 2: Analysis of Ticket Handling .....                      | 34   |
| Table 3: Request Arrival Schedule .....                         | 36   |
| Table 4: Incoming Requests and Service Time .....               | 37   |
| Table 5: Analysis of Proposed Process Performance .....         | 55   |
| Table 6: Performance Analysis of Three Models .....             | 57   |

## **Chapter 1**

### **Introduction**

Call centers, or in contemporary terms, contact centers, are essential parts of most businesses or organizations. Customers' perceptions of an organization are greatly affected by contact center performance because these centers serve as an interface between an organization and its clients.

#### **1.1. Importance**

The role of a call center as a heart of any business has had a dramatic evolution and has been a target of numerous researches all focused on improvement and efficiencies. Call center is one of the most significant ways of serving customers' requirements. Thus, many large organizations have a contact center that customers or users can access the organization and vice-versa, by telephone, fax, email, web-form, etc. Contact centers hire agents to serve customers remotely, via different contact methods. So, they have evolved into the primary contact point between customers and their service providers and have played an increasingly significant role in more developed economies. In North America, contact center employees are about three percent (3%) of the workforce (Pierre, 2006), and regarding U.S. Bureau of Labor Statistics published on 2009, there is an expectation of 25% growth from 2006-2016. Moreover, according to Bocklund and Hinton, 2008, although contact centers are technology oriented, often 70% or more of their operating costs are devoted to human resources costs. So, the increasing size of the industry and its concentration on human resource inspired us to explore potential ways of optimizing a call center's performance.

Call centers are growing and changing rapidly. New features and technologies appear almost every day. Deloitte Company 2013 Global Contact Center Survey results proved this fast growing trend. 77% of survey respondents, who represent 560 contact centers, expect to maintain their size or grow in the near future. Also, the survey identified that overall business growth and the need to improve customer service are the two primary drivers of contact center growth.

Running a contact center requires a well-defined balance between the quality of service and agent utilization; thus, a variety of queuing theories have been introduced. In studying contact center models, different inputs can be considered; these include request arrival rates, number of agents and their performance, the required service time for different technical categories, and the time that customers tolerate waiting in the queue. Outputs of the contact centers analyses can differ based on what is analyzed and which inputs are used. Nevertheless, these outputs can enable managers to make a decision about contact center scheduling, number of required agents or routing policies.

One of the most significant roles of call center managers is to plan the workforce and predict the size of the center by considering contact volume. This includes planning for hiring new employees, work schedules, required working shift and training. They need to decide on the number of agents possessing different skill types and to provide training sessions to encourage the desired quality of service at minimum cost. Managers also have to schedule the workforce and design a proper call routing process to optimize staff usage and skill utilization.

In almost every call center the arriving requests are classified based on request types and required technical skills to handle the requests as well as the request priority, which indicates the importance or urgency of the request.

Agents are also categorized in different skill groups based on their shared capability and expertise in different technical fields. Requests arrive randomly according to some statistical distributions, and the contact center policy determines how the routing process will occur. If a request finds an available agent, it may be assigned immediately; otherwise, it will be queued. Obviously, when there is no incoming request or work in hand, the agents become idle. In most contact centers, request assignments happen based upon the routing policies which also involve the request priorities.

The source of our data is the Rowan University Support Desk where the potential number of customers is about 15,500 which include faculty, students and staff. In this paper, we summarize an analysis of Rowan Support Desk operational data. The data span all twelve months of the 2012-2013 academic year. The data source consists of about 10,000 requests that arrived at the center over the period of study. About 6200 requests were received through emails and web-forms, 3100 through phone calls, and the remaining requests arrived through other sources.

The current path that each call follows through the center is as follows: a customer calls the telephone number associated with the call center; Cisco Agent Desktop (UUCX) uses an algorithm to distribute the calls to phones that are in ready mode. The agent with the longest ready mode is the person that will receive the incoming call in the queue. When all the agents are busy, the customer waits in queue for the next available

agent, or the customer has the option to email to the support desk, and that request will be then addressed using a first-in/first-out (FIFO) policy.

Requests entered into the queue after normal business hours are addressed the next working day using the FIFO method. On the next day, if the phone does not ring at 8:00 a.m. when an agent becomes available at the center, the request in the queue will be addressed. If “walk-in” customers are at the front window, they are addressed first. If the phone rings while a customer is at the front desk, if there is more than one support desk agent at the support desk at this time, responsibilities are split. Customers who come to the front desk are addressed immediately by staff members stationed there (mostly student workers). Otherwise, support desk agents (SDA) answer the phone first, and then address the request in the queue.

## **1.2. Problem Statement**

Rowan University’s support desk has a rate of 71% of tickets that take more than 2 days to complete which is translated into long lasting open tickets and customers’ dissatisfaction due to the long process time for resolving their issues. The current SLA, Service Level Agreement, is way above standards of an effective support desk and the expectation of the customers. Service level is an agreement between service providers and customers which defines the level of service and service quality. Therefore, every service provider has a unique SLA. However, in a report generated by Aberdeen Group, they analyzed and compared best in class organizations performance and it was reported these organization had performance metric that included 87.1% SLA compliance rate (Aberdeen Group, 2007).

This issue inspired us to conduct preliminary research to identify the most critical factors that need to be corrected carefully in a call center; determining these elements enabled us to examine other alternatives and their impact on the overall performance of the Rowan support desk.

### **1.3. Scope of the Study**

This thesis identifies the critical factors that affect the average handling time of the Rowan University Call Center consisting of different departments such as engineering support, web services, Blackboard, support desk, and library support. This study only focuses on the support desk performance.

### **1.4. Research Objectives**

Our goal is to identify the most optimal system for resolving tickets in a timely manner, given the volume of the tickets and the project constraints.. Therefore, we will compare a contact center's performance, when all agents have the same skill set, with a center where experienced agents are distinguished from generalists. In this scenario, if the generalists cannot handle the request within a predefined threshold, the experienced group will continue the process. In order to compare these two alternatives, we build computer models to determine which of the two is more efficient in terms of service speed and number of solved tickets.

To enable an appropriate comparison of the two alternatives, we first identify effective elements on service time in a call center such as average handling time, service level and waiting time. Our belief is that our proposed solution can help the support desk managers to succeed in the execution of their center and provide high quality services to their customers.



## **Chapter 2**

### **Literature Review**

In the following section, I will present relevant research and publications that this thesis builds on.

#### **2.1. Contact Center Businesses**

In recent decades the call center industry has been the center of attention in the field of operation research and optimization. Several works have been published in this area to study different perspectives of a contact center business.

In literature call centers are defined as centralized offices which are designated to serve customer requests by telephone; call handling assignments are often based on the required skills for providing service. It is obvious that all agents are not at the same skill level, and also training all agents to become capable of handling all request types is not cost effective. More experienced agents are able to handle calls more appropriately and faster than newer agents.

Most organizations have evolved from typical call centers into contact centers. Contact centers are based on the same principles as call centers; however, they communicate with the customer via various methods. These transformations caused an increase in call volume and attracted more customers who are seeking better services in a shorter time. As a result, call center dependency upon agents for handling a variety of requests has been boosted. (Avramidis, Athanassios N., et al, 2008).

Koole, who has done numerous researches in the call center industry, in one of his most significant works which was published in 2006 with Auke Pot, mentioned, “The most important resource of a call center is the agents. This means that the structure and

processes of a call center should be such as to maximize the effective utilization of the workforce.” They did a detailed review of routing and staffing policies in multi-skill contact centers. Furthermore, they characterized associated issues and problems in running a contact center, and divided call center decisions into the following five major categories:

1. Strategic decisions: Top managers are in charge of this category. Strategic decisions are related to the call center’s role in the organization and type of services to be delivered. Also, managerial decisions about budget are made in this category.
2. Tactical decisions: This category is about resource usage, employment programs, and training.
3. Planning decisions: The planners make decisions about employee work schedules usually on a weekly basis. This agent planning is called “workforce management”.
4. Daily control: These decisions are made to react to ongoing circumstances of the call center. Monitoring service levels and productivity of shift leaders are examples of this type of control.
5. Real-time control: Decisions that are made in real-time by software such as an automatic call distributor (ACD). Incoming request assignments to agents are examples of this kind of decision. These examples are not complex, but some cases such as skill-based routing require a well-defined algorithm to make the final routing decision.

Past research in the field of call centers can be categorized as follows:

- Queuing theory
- Arrival models
- Workforce Management models (WFM)
- Routing models
- Simulation

Call center staffing and finding an optimal scheduling solution has been a popular topic in call center study. The focus of the earlier works was to achieve the optimum number of agents considering call center constraints, such as cost, customer waiting time, and service level. Some notable works in this field are summarized in the following paragraphs. However, there is a need for research in the area of optimizing call center performance using the available agents. Hence, our approach will be improving Rowan University call center performance using existing operators and we will compare its result with the alternative of increasing number of staff.

Mason, Ryan and Panton, 1998, applied heuristic and optimization approaches to schedule staff and find a near-optimal staffing level. They developed a simulation-based system for operator scheduling at the Auckland International Airport, New Zealand. A heuristic search was used to identify optimum staffing levels for different sections in the airport. Afterward, an integer programming model was developed which used the number of required staff as the input. This model allocates full-time and part-time operators to different shifts of a day. By applying these models they reached remarkably lower staffing allocation.

Ward, 1999, presented an infinite server queuing modeling to launch a dynamic staffing model in call centers with the goal of promptly serving all customers. The advantage of dynamic staffing is its tractability which is so useful in estimating the mean and variance of future request arrivals. Recent arrivals are used to estimate short-term staffing requirements. Also, historical data such as call type is necessary to predict waiting time. Then the model utilizes both historical data and the record of customer demands to forecast the number of future incoming requests.

Larson and Edical, 2000, proposed techniques for planning and scheduling part-time staff to improve customer queuing experience. Their concentration is on financial services institutions which, the same as call centers, face a variety of customer demands, which often can be modeled as non-homogeneous Poisson customer arrival, a Poisson process with a rate parameter that is a function of time. Based on this technique, staff allocation can be done by using an internal pool of flexible workers, or taking advantage of a labor supply agency.

Ridely, 2000, delivered an analytical and simulation based approach for design and planning of a contact center. Ridely set his objective to optimize contact center performance, while considering three contact channels, call, Email and fax. He also considered different targets for waiting time and service level. In this model, the system performance is monitored by metrics such as waiting time and expected waiting time distribution, total time in the system, and percentage of answered calls in a given period. In the analytical method, the assumption was all the operators could handle all incoming requests. Moreover, Ridely considered exponential distribution for incoming requests and

service time within different traffic classes, in which every traffic class had unique arrival and service time rate as well as a queue priority of its customers.

Whereas, there will not be an exponential distribution for service time and arrival rate in simulation based models. Furthermore, these models dealt with different skill levels of agents and finite queue length.

Borst, 2002, attempted to establish staffing heuristics to apply to large call centers. He analyzed call center characteristics and developed a framework to optimize a large call center performance using the Erlang C formula. In this research, Borst describes an optimal staffing level that trades off agents' costs with service quality. However, there are several assumptions associated with using the Erlang C formula, but the most problematic one is considering no abandonment.

The above researches were a small part of numerous studies in the area of optimizing service sector staffing. However, no research has been done to enhance a call center or service section performance by reorganizing staff and rerouting long-lasting open tickets. Recently, the use of computer models and simulation in studying call center behavior, which is the focus of this thesis, has been increased. Mehrotra & Fama (2003) noted that applying simulation models has been influential in call center design and management.

The complexity of call centers, even relatively small centers, and their function makes the simulation usage much more vital. Simulations may be generated with the application of high technology products such as automatic call distributors (ACDs), interactive voice response (IVRs) and computer telephony integration (CTIs) to facilitate answering incoming calls and/or routing both callers and callers' information to available

agents (Robbins, Medeiros, & Dum, 2006). These types of advanced technology are more available in contemporary call centers known as contact centers.

Changes in call center operations and widespread usage of technology has been following a considerable increase in contact volume; also, customers expect better quality and faster services from these contact centers.

Growing complexities require more advanced approaches. Athanassios N., and L'Ecuyer, 2005, observed simulation as the most feasible alternative for accurate performance measuring and supporting decision processes, because of uncertainty and complexity in modern contact center performance and management.

Mehrotra, Vijay, and Fama, 2003, considered the following three simulation methods in studying a call center:

1. Traditional simulation analysis: The purpose of creating a simulation model is to collect data from various sources such as historical records, time series models, and expert judgment, and analysis of specific operations in a call center.
2. Automatic call distributor (ACD) and computer telephony integration (CTI) routing: Most of the advanced ACD and CTI packages contain a routing simulation. This feature allows the routing designer to analyze the effect of different routing policies.
3. Agent scheduling: Scheduling is a complicated problem, and it becomes more complex when both arriving calls and agents' performance do not follow a steady pattern. Therefore, most call center software utilizes simulation models to deliver optimal results.

Each of the above methods provides us the outputs containing the following measures:

1. Queue statistics: Average speed of answer and service level are the two major queue statistics. These metrics can be obtained from analyzing the interval requests behavior;
2. Abandonment rate: This indicator is of great importance, particularly in call centers which sell services or products. The abandonment rate shows the number of customers who leave the queue before entering a system and connecting to an agent. This metric is considered a measure of customer satisfaction (Feinberg, et al. 2000);
3. Volume statistics: This data category is subject to the number of calls that are answered by an agent rather than the calls that reach the answering machine or no answer.

We can apply computer models and simulations to validate different alternatives. Simulation is also useful to perform “what-if” analyses in order to manage and improve call center performance and advance planning for possible circumstances. Bouzada. (2009), comprehensively studied the purpose of simulation in his paper. He categorized the reasons, notably, as the following six items:

1. Making our models complex enough to cover all the performance details, so we can assure our model outputs are accurate;
2. Underestimating the service level calculated by Erlang formulas due to ignoring abandonment rate in these formulas;

3. Calculating some of the other important metrics such as abandonment which cannot be studied while using analytical approaches;
4. Defining upper and lower boundary limits of important metrics; so, we do not have to force our analysis with the average data;
5. Enriching conceptual intercepts by adopting the experimental approach, which allows us to trace system behavior and its performance metrics; therefore, determining the reason for queue formation and long waiting time;
6. Creating understandable graphical models.

So far, we have reviewed the importance of applying simulation and modeling to predict the results of changes in a call center's operation. Next, we cover the importance of process improvement.

## **2.2. Contact Center Models**

Raik Stolletz (2003) in his book concentrated on analyzing and optimizing an inbound call center performance by using queuing models. He elaborated mathematical methods and algorithms to analyze the relevance of the number of agents and trunk lines to a call center's technical capacity. This book describes the following four broad models of call center interaction with customers:

- Inbound call center – Exclusively handles inbound calls and is a model for receiving a large volume of requests or calls from customers by telephone. Inbound call centers typically handle telephone requests for product or technical support, account assistance, sales, subscription management, billing and other inquiries from consumers.



- Outbound call center –This model is designed to make a large volume of outbound calls to customers. Outbound call centers typically handle telephone communications for sales, account upgrades, subscription offers and telephone marketing.
- Blended call center – Combining automatic call distribution for incoming calls with predictive dialing for outbound calls, it makes more efficient use of agent time as each type of agent (inbound or outbound) can handle the overflow of the other.
- Web-enabled call center – It is a central location that a customer can reach by voice using a button on a website or an internet call program, also called a help desk. In this type of call center is a customer department that allows consumers to speak to a company representative. With web-enabled centers, the computer user can make a voice call to a company representative online instead of calling on the telephone.

### **2.3. Contact Center Services**

Kerstin Norman has published several researches to analyze correlation of call center work on agents' health. In her research done in 2005, she explains the characteristics of work in a call center; she also presents physical and psychosocial effects and health-related outcomes of call center jobs on agents in Sweden.

According to Norman, 2005, contact center agents are mostly in charge of handling incoming and/or outgoing calls. Typical services of outgoing calls are advertising campaigns, market research and selling via phone. On the other hand, there are many other activities that can be accommodated in an incoming contact center; these

include customer service, technical support, providing information, taking orders and help desk functions. Since our focus is contact centers, this communication is not limited to telephone calls but expands to a variety of contact channels such as the examples mentioned earlier.

#### **2.4. Contact Center Structure**

Gable, in his 1993 research, presented a conceptual overview of call centers and call center requirements in terms of products, design, and ongoing managerial policies to achieve success. Moreover, he mentioned four categories of cost function: the network layer, the equipment layer, the personnel layer, and the report layer. Of these four categories, the personnel layer is the most expensive.

Call center personnel handle requests with their specific skill sets and experience. If the request routing considers agents' skill sets, that is a multiskilling call center. Request routings refers to the policy of assigning calls (or all types of requests) to agents. Most modern call centers perform skill-based routing (Gans, Koole and Mandelbaum, 2003).

#### **2.5. Contact Centers Key Performance Indicators**

In this section, some of the most important performance measures of a call center are reviewed. These measures can be categorized as both qualitative and quantitative measures, the majority of which are qualitative. Considering a call center's requirements and shortfalls, we may concentrate on one or more of these indicators to enhance the performance. However, there are no unique average numbers to use as benchmarks. These measures are mostly dependent upon call center performance itself and predefined targets and service level agreement.

The NAQC's, North American Quitline Consortium, issue paper on call center metrics provided detailed descriptions of each measurement and classified call center metrics in three broad categories relevant to service, quality, and efficiency. Below we summarize those explanations:

- Service Measures indicating those metrics that show speed of performance and ease of access to a variety of services. Most of the service metrics are associated with overall call center performance; however, some of these indicators can be affected by individual or group performance.
- Speed of service group indicators includes service level, average speed of answer, and longest delay in queue. On the other hand, in the accessibility category we can look at blockage, hours of operation, and abandoned calls. Brief explanations of these indicators are in the following paragraphs.
  - Quality indicators are the metrics consistent with service quality. Two major examples of this type of indicator are metrics affecting the process to handle calls and resolution time.
  - Efficiency metric indicators are associated with resource usage. We can calculate staff efficiency by monitoring their performance while handling requests; moreover, by tracking cost and resource utilization, we can determine performance efficiency. This group of indicators may be expressed in: contact handling, resource utilization, and cost efficiency.

- In the category of contact handling we may consider average handle time, after-call work time, and on-hold time. The resource utilization group includes agent occupancy and availability, schedule efficiency and adherence, and staff shrinkage or nonproductive time. The cost efficiency group contains conversion rate and cost per call metrics.

As such, this metric can be measured by adding up average talk time and average after-call work time. Although this indicator is influenced by request type, there should be an acceptable time period for closing any type of request. Thus, trying to over-shorten AHT, Average Handling Time, may influence the quality of conversation and services.

There is no predefined industry standard for AHT; it can be specified based on every single center's performance and targets. But, we need to keep track of this indicator in order to monitor whether the agents' performances are in a satisfactory range or not.

## **2.6. Routing and Prioritization Problems in Contact Centers**

As mentioned above, implementing appropriate routing policies to meet desired service level while utilizing fewer agents is the main goal of every contact center improvement effort. About 70% of a contact center's overall budget is allocated to its employees; therefore, it is crucial to optimize agent numbers to control costs and encourage profitability.

Akhtar and Latif (2010) addressed the following six scenarios of routing and prioritization policies that have been studied so far:

Scenario 1: There is one type of request entering the system, and a group of similar agents are in charge of handling requests. An agent with the longest ready mode will answer the requests based on FIFO policy.

Scenario 2: There are two types of incoming requests with one group of equally skilled agents to answer the requests. So, there should be a defined policy for the order of serving these two types. For example, when there is a VIP group of customers in the system, a policy may address their requests first and then handle the other group.

Scenario 3: Two types of requests are handled by two groups of agents, specialists and generalists. Each group is in charge of serving one type of request; however, the generalists can assist either request type when there are not enough specialists available.

Scenario 4: Again, there are two groups of agents and two types of requests. In this case, the incoming requests are being served by both groups. But, each group is skilled in one type of request as primary and another as secondary. Imagine group A of agents are skilled in type 1 requests, when there are both type 1 and type 2 in a queue, type 1 has a higher priority for this group.

Scenario 5: There are three types of requests and two groups of agents A and B of equal skill level. Group A is in charge of serving type 1 and 2 of requests and group B is responsible for answering requests type 2 and 3. If we consider type 2 as VIP requests, they will be the first requests to be served. After that, both groups of agents handle requests from existing queues based on FIFO order.

Scenario 6: This case is the most popular scenario in contact centers. It occurs when there are three groups of agents, consisting of two specialists with different skill sets and a generalist. These groups are in charge of handling two types of requests 1 and

2. All the groups have the same skills; however specialists can handle a request faster than generalists and their efficiency may be equal to or less than expected AHT (Shen and Huang, 2008). When a request enters the system, specialists have higher priority to pick the request, and if they are busy, the request will be routed to a generalist. When requests require a specific skill, agents that have that as their primary skill should handle those requests. If they are busy, the group that has it as a secondary skill serves the requests.

All the possible routing policies were introduced in this section. Hence, to date, there is no previous research focusing on pooling specialist and generalist agents to take advantage of their performance together. In this study, we do not separate these two groups of agents at the first step; however, in a situation when a request requires proficiency and experience, or for any reason handling time takes longer than a predefined threshold, the request will be passed to specialist agents for further attention.

## **2.7. Analytical Models of Contact Centers**

Generally, call center planners approach staffing and scheduling problems by using Erlang formulas as follows:

**2.7.1. Erlang-B formula.** The most common traffic model which works when an incoming call receives a busy signal, and instead of being queued, it vanishes. The Erlang-B formula can calculate lost calls due to blockages. Cooper (1997) indicated that the formula is valid only when the time between incoming calls follows a Poisson distribution; and, it is valid for any type of call handling time distribution.

**2.7.2. Erlang-C formula.** According to Mandelbaum and Zeltyn (2005), “The classical M/M/n queuing model, also called Erlang-C, is the model most frequently used in workforce management of call centers.” Erlang-C considers Poisson arrivals at a constant rate  $\lambda$ , exponential service time with rate  $\mu$ , and  $n$  independent statistically-identical agents. According to Kleinrock and Leonard (1975), this model assumes that an arriving customer will need to be queued instead of being served immediately, and the formula calculates the probability of queuing. Using this model, all the incoming calls stay in the system until they can be handled.

**2.7.3. Erlang-A formula.** Since Erlang-B and Erlang-C formulas ignore abandonments of calls. They are not powerful enough to model real-world problems. Garnett, Mandelbaum, and Reiman (2002) presented a simple approach for modeling abandonment. Their suggestion was to modify the Erlang-C formula and consider an exponentially distributed “patience time” with each arriving caller.

The limitations associated with analytical tools and models force contact center planners to make assumptions in solving problems. Anton (1999), Bapat and Pruitte (1999) indicated the main assumptions as follows:

- All the arrival calls are the same type.
- Call handling is based on order of arrival (FIFO: first in first out).
- Agents employ similar skill sets for handling various calls. (Because, we assume all the calls are similar).

Franzese, et al (2009) indicated that, although many efforts have been made to enrich analytical models and assure more realism, so far, none of their solutions are as strong as the results achieved by discrete event simulation.

According to Bapat & Pruitte (1999), and also Koole (2004), models which are created by an Erlang formula can be used as input parameters for simulation modeling.

Krungle (1998) indicated the following situations that simulation models performed more appropriately than other analytical tools:

- Complexity of existing analytical tools and models;
- Poor statistical results of current analytical models;
- Inability of recognizing bottlenecks in a call center process;
- Inadequate details of analytical models;
- Clarity of animation for presenting results to managers.

Simulation application in call centers has grown recently, and it is noteworthy that call processing simulator software developed by AT&T in the United States in 1979 was among the pioneering simulation tools that have been applied to call centers. AT&T analyzed their call center customers to identify bottlenecks and demonstrate the viability of solutions, and by 1993 they had carried out approximately 2,000 case studies (Brigandi, 1994).

## **2.8. Key Requirements of Contact Center Success**

When discussing contact center performance management, the following three categories can be viewed for improvement:

1. Contact center design: A long-term problem to identify various classes of customers and server types. In this category, we should also consider multi-skilled servers, agents, and customer classes that can be addressed by different agent skill levels.



2. Staffing: A short-term issue relevant to determining the number of agents of different skill types for handling a specified number of requests. For this category, it is necessary to look more carefully at overlapping skills and also the resource requirements of different working shifts.

3. Control: A daily problem of request routing and agent scheduling. Control also involves the assignment of agents to customers and customers to agents.

These three issues are the major subjects in managing a contact center. However, due to the complexity of identifying and combining all three of these categories, they are usually studied separately in the literature. (Armony and Mandelbaum, 2004).

Prior to determining the appropriate design, staffing and control of the contact center, we need to set target performance indicators. The most popular metrics to track a call center performance is service level; it is due to the simplicity of measuring this indicator. It denotes the percentage of calls that are “on hold” for less than a particular period of time. The target service level for incoming calls is different among businesses, but it is generally acceptable to be “80/20.” This means that 80% of the incoming calls are answered in 20 seconds or less (Saltzman & Mehrotra, 2001). Another commonly used metric is average handle time (AHT), which is denoted as a highly variable measure because of differences in required services and the way that agents handle various requests. (Louis Franklin, 2010).

The main concern in the Rowan support desk study is the gap between target AHT and current performance. Performance gaps can cause a huge waste of money. In order to overcome this problem, the entire department should be informed of these gaps, and immediate actions should be taken to eliminate the gaps in order to increase

performance to a best-practices level, and strengthen the call center's competitive advantage (Anton and Gustin, 2000). Some of the possible solutions, from the literature, to overcome the AHT gap are discussed below.

Call center operation improvement is not limited to a specific department or individuals. It requires cooperation of many people, including direct involvement of the call center manager, call center supervisors, HR manager, information technology manager and telecommunications manager. Engagement of these people to achieve a desired AHT is briefly explained by Anton and Gustin (2000).

- Call Center Manager: In order to reach the target AHT, call center supervisors need to provide the managers with comprehensive reports and inform them about any variance from the target range. Thus, the call center manager can monitor the KPIs', Key Performance Indicator, trend line.
- Call Center Supervisors: It is the supervisors' responsibility to evaluate the average handling time and identify the reasons for a long AHT. There are several factors to look for: 1- adequate number of agents, 2- comprehensive and accurate scripting of the requests, 3- degree of schedule adherence. Accordingly, supervisors should keep track of the mentioned factors, determine the reasons for variances and share them with the agents in order to reach the targets.
- HR Manager: In order to be informed about the recruiting and training requirements, HR managers need to have a close cooperation with supervisors. Conducting training sessions regarding products or services, and facilitating the agents' access to the relevant information in databases can be the HR manager's responsibilities to improve AHT.

- Information Technology Manager: IT managers should assure that required technologies conform to the standards, and upgrade the technologies when indicated. Although, it is not easy to follow the rapid changes in the technology, it is the IT managers' role to assure accurate data that can be provided with existing technologies.
- Telecommunications Manager: The importance of communication is obvious in every organization in order to conquer and eliminate performance gaps. For example, call center agents must be informed about new product releases or service launches in order to respond properly and minimize AHT.

In this chapter we have covered some of the relevant articles from previous literature. In the next chapters our approach to implement and model the proposed solution will be discussed thoroughly.

## Chapter 3

### Research Methodology

This chapter presents the research methodology applied for this research and how it has guided data collection, analysis and development of the new model. In the following sections the data collection steps are described in detail. These steps include face-to-face interviews with the support desk staff, an open-ended survey and analyzing data extracted from the support desk system.

#### 3.1. Qualitative Research: Methodology

Collecting relevant data is an essential part of most scientific research. In this paper, data was acquired from the Rowan University Support Desk, which is our case study. Data was collected in several different ways. Performance data was obtained from the support desk system. Next, ten direct interviews from November 2013 until May 2014 were conducted. Parts of the interviews were held with Rowan Support Desk employees and managers.

Open questions were asked, giving respondents the opportunity to answer each question within their own interpretation, and to elaborate on possible causes of the long-lasting problem of open requests. Furthermore, interviews offered the opportunity to ask follow-up questions in order to gain a better understanding of why tickets are open and client issues are unsolvable for a long period of time. Interviews with managers provided a comprehensive knowledge of current request handling procedures, and steps taken offered the basis to identify the primary area of improvement.

The next action was conducting a survey among support desk agents who were asked a set of simple and straightforward questions relating to long request handling time.

The survey was designed to gather specific information which would lead to protocols to troubleshoot their performance.

### **3.2. Sample Design**

For the purpose of face-to-face interview, a group of four employees were introduced randomly by the support desk manager. This group included two specialists and two generalists.

On the other hand, in order to be unbiased, all the agents were involved in the process of conducting surveys which included all the ten operators. Five of the ten support desk agents were students who worked in the support desk part-time. The other five respondents were full-time employees. Four employees were experienced; one was inexperienced. One experienced employee managed the support desk as well as handled requests.

### **3.3. Questionnaire Design**

In this survey, open ended questions were chosen. Agents were questioned about the support desk issues from their own experience and observation. We found open-ended survey questions more appropriate; Iyengar, 1996 mentioned, open-ended questions have the advantage of “nonreactivity.” That means that our respondents could state their opinions in general, and we did not direct them to think of particular causes or treatments. To facilitate their responses, contact center issues were categorized in four (4) broad groups: 1- Process, 2-System, 3- Staff and 4- Environmental issues.

After gathering the survey results, a brainstorming session was held with four full-time employees in order to share ideas for process improvement. That session

allowed us to investigate face-to-face with the support desk agents the most critical and influential issues of long-lasting open requests.

### **3.4. Quantitative Research: Data Collection Process**

In the following section, we describe our data collection method from thousands of records and how we processed these records into a database for ease of analysis. The only complete records of user and system behavior in interactive voice response (IVRs) are completed calls. Therefore, our approach was limited to extracting data from incoming calls that ended with a conversation with a live agent and the arrival of other requests from different sources.

Arrival requests are recorded from the support desk reporting system. Recordings of complete requests require loading of a large amount of data that makes the analysis more complicated. For simplicity, we selected the most important data modules for our purpose and summarized the data in an Excel file.

### **3.5. Quantitative Data Sample**

We focused the scope of our study upon support desk data which generated 9717 tickets during academic year 2012-2013. The following table represents the number of generated tickets per different contact channel for this period of time:

Table 1

*Number of Tickets per Different Contact Channels*

| <u>Request Mode</u> | <u>Number of tickets</u> | <u>Percentage</u> |
|---------------------|--------------------------|-------------------|
| Email & web form    | 6247                     | 64.29%            |
| Phone Call          | 3031                     | 31.19%            |
| Other (walk in...)  | 439                      | 4.52%             |
| Total               | 9717                     | 100%              |

The next illustration depicts the data trends for the academic year 2012-2013. Bars show cumulative number of tickets per month. Receiving more requests at the beginning of fall and spring semester is the main reason of variation in request loads.

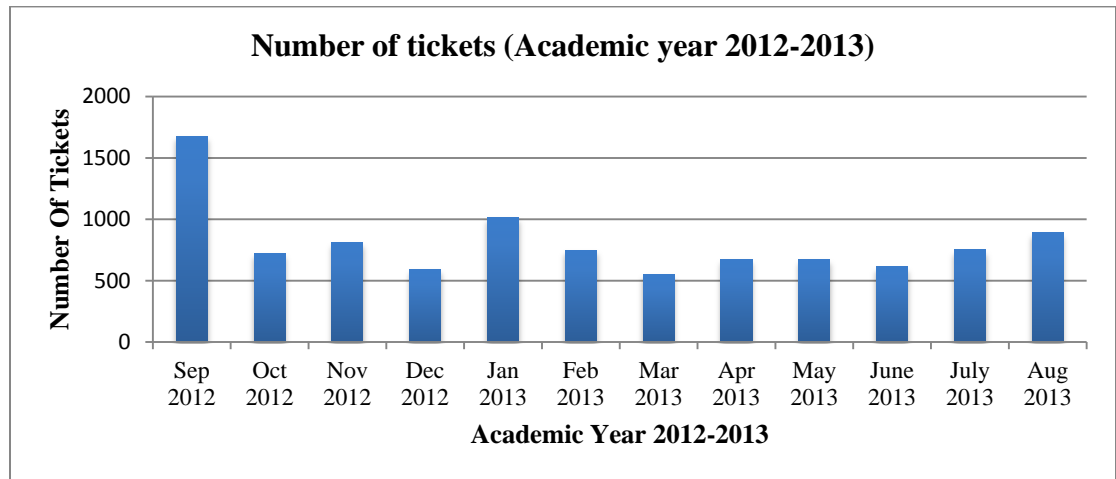

Figure 1. Number of tickets (Academic year 2012-2013)

### 3.6. Limitations and Assumptions

**3.6.1. Research limitations.** In this thesis, I used a student version of Arena Rockwell simulation software. This version is free to download from the Rockwell company website; although the student version has some limitations, the results are valid and do not take away anything from the research overall findings.

Given the limitations of the student version of the simulation software, which does not allow users to go beyond 150 entities limit, we set the replication length at one week to avoid exceeding the maximum number of entities for the demo version. Obviously, if we could expand the simulation length, the result would be more and the margin of error would be even smaller.

Another factor we considered was the randomness of requests assigned to the agents. The model would be more accurate if I knew the exact and current percentage of tickets assignment to the agents. However, there is not any specific data for the ticket assignments; so, we analyzed the old data and calculated the percentage of tickets that each agent could handle for the duration of our study.

Moreover, we focused on the variance in agent performance, as budget constraints and time constraints makes it inapplicable to analyze all the possible alternatives such as conducting training sessions, upgrading the support desk technical system and facilitating communication with other relevant departments.

**3.6.2. Project constraints.** We considered the majority of possible causes for the existing issues; however, there are always some constraints associated with any project. The current constraints for improving the support desk performance can be summarized as:

1. Embedded support desk system which cannot be customized easily;
2. High cost of the system upgrade;
3. Time-consuming processes for training sessions and workshops to improve performance.

Bocklund and Hinton, 2008, consultants of Strategic Contact Inc. in their report of Cost Structure and Distribution in Today's Contact Centers, explained cost allocation to the different sections of a call center. Figure 2 is extracted from those data and shows nearly 80% of a medium size contact center's costs are devoted to human resources. These costs are associated with customer service representatives, supervisors, managers, operation analysts and technical support staff.



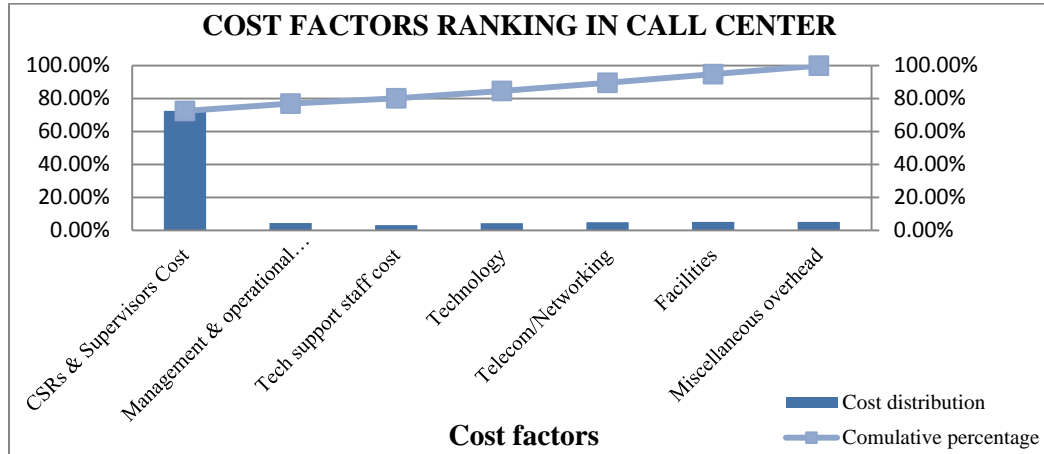

Figure 2. Cost Factor Ranking in a General Call Center

The identified issues in addition to the associated constraints directed us to concentrate on a fast track and cost effective approach for process improvement. Looking at the considerable difference in agent performance and limitations of student-worker engagement, in addition to the time-consuming process of training new employees, motivated us to develop a new process. In this practice, our effort was focused on modifying the current routing process with the goal of decreasing request handling time by using the available resources. This approach is explained in detail in the following chapter.

**3.6.3. Research assumptions.** We assumed that all the agents and the support desk manager provided accurate and truthful responses. We limited our data collection to the academic year 2012-2013, and all current agents have been active since then, also the performance of the agents who had left the support desk was not taken into account. We thus assumed their performance may have generated data similar to the current employees.

## **Chapter 4**

### **Data Analysis**

This chapter presents a detailed analysis of the quantitative and qualitative data that was gathered from surveys, interviews and support desk system. As it will be explained later, the result of this analysis was the motivation of conducting this research and studying the effect of a new improved process on current performance of Rowan support desk.

#### **4.1. Analysis of Survey and Interview Responses**

We collected the survey responses from the ten agents and carefully analyzed their answers. The following outline reflects identified issues gleaned from the survey and the brainstorming session.

The first concern of the support desk operators was on system issue. The agents' responses on systems issues reveal that they are struggling with system technical complexity which makes it difficult for them to work with the system without comprehensive training on the features. As the support desk system is an embedded system, it is not possible to customize it easily. Furthermore, the current version of the technical system has limitations in capability which are costly to upgrade.

In addition to system issues, there are conflictions in the request handling process. Lack of communication between departments makes the ticket handling procedures a time-consuming process. Also, when a ticket is generated, the process for identifying issues and troubleshooting takes a long time.

The last category of Rowan Support Desk issues refers to staffing problems. Lack of adequate training sessions for new employees, in addition, to insufficient number of

agents increases the work load of experienced agents. Moreover, as mentioned earlier some agents of the Support Desk are student workers who have limitations in their working hours.

#### 4.2. Quantitative Data Analysis and Findings

The following analysis of handling time for requests per agent reveals an obvious difference in their performances. This difference inspired a modified process that can involve experienced agents properly. Figure 3 shows every agent performance in the period of the study. Tickets process time are classified in 4 categories, 0-2, 2-3, 3-20 and more than 20 days. 0-2 days shows tickets that were solved in less than 2 days and so on. The bars in front of each time elapsed category reflect the number of tickets that could be solved within that category. The last 5 rows indicate the student workers' performance.

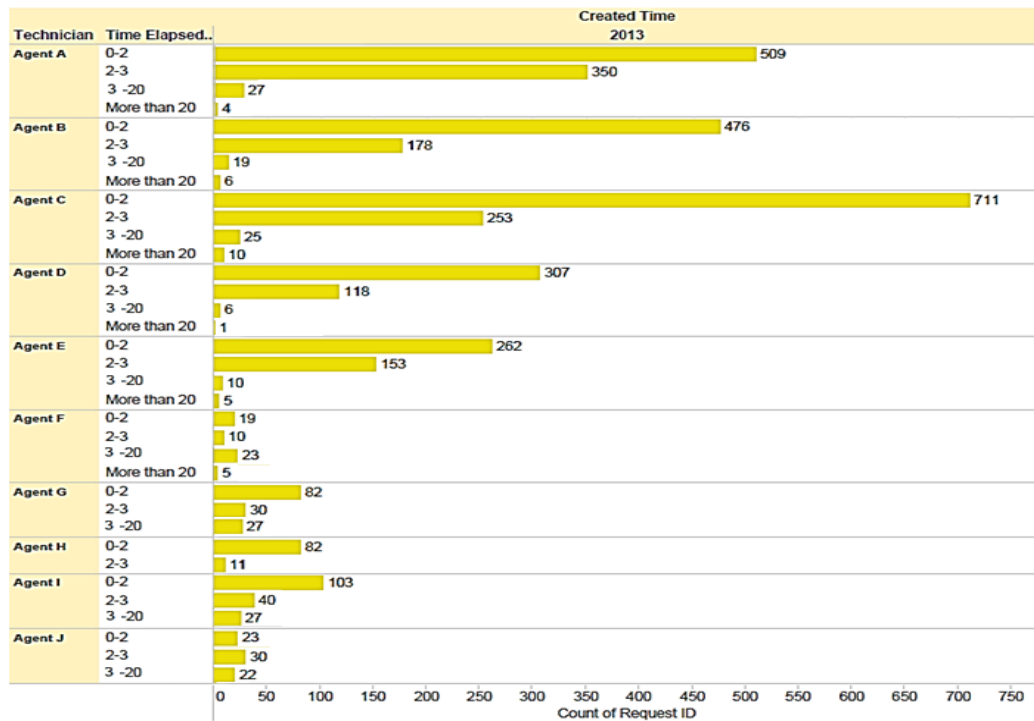

Figure 3. Agents' Performance Analysis

## Chapter 5

### Support Desk Performance Model Description

Computer simulation can be used to model and analyze real-world problems that cannot be successfully approached by other types of analytical techniques (Niu, Qing, et al, 2011). In the past few years, Arena has been the world's leading discrete event simulation software. In this study, Rockwell Software's Arena was used, and models were set up to implement the simulation.

#### 5.1. Model Explanation

The Rowan Support Desk, similar to most other contact centers, consists of an interactive voice response (IVR), telephone trunk lines, automatic call distributor (ACD) and agents to handle customer requests.

Mehrotra (2003) mentioned the following inputs as the primary factors for creating model and simulating a call center:

1. The incoming calls (which include all types of arrival requests in this research).
2. Agents performance,
3. Call center working schedule.

In addition, the routing policy determines how calls are handled and the interactions between agents and calls

#### 5.2. Agent Performance

As stated earlier, the Rowan Support Desk has a staff group of 10 agents with different skill level. Each agent is trained to handle all types of incoming requests. However, their proficiencies in solving issues are not the same. In the following table, we

compared every agent's performance with expected handling time. Expected handling time was obtained from calculating the average handling time for the academic year 2012-2013. Then each agent's AHT was compared to the expected handling time and it was expressed by a coefficient. These coefficients are referred to as the weights of the agents' performance.

Table 2

*Analysis of Ticket Handling*

| <u>AGENT</u> | <u>STATUS</u> | <u>AHT(Hrs)</u> | <u>WEIGHT</u> | <u>TICKET ASSG</u> |
|--------------|---------------|-----------------|---------------|--------------------|
| A            | *FT           | 52.92           | 0.63          | 26.0%              |
| B            | FT            | 82.32           | 0.98          | 18.0%              |
| C            | FT            | 78.96           | 0.94          | 19.0%              |
| D            | FT            | 112.56          | 1.34          | 8.2%               |
| E            | FT            | 122.64          | 1.46          | 9.8%               |
| F            | **PT          | 23.52           | 0.28          | 1.3%               |
| G            | PT            | 64.68           | 0.77          | 2.6%               |
| H            | PT            | 58.8            | 0.7           | 2.5%               |
| I            | PT            | 121.8           | 1.45          | 3.2%               |
| J            | PT            | 88.2            | 1.05          | 9.5%               |

Standard AHT(AVG)= 84 Hours

\*FT= Full-Time

\*\*PT=Part-Time

Considering an incoming call, it is initially served by the IVR. If a customer chooses to connect to an agent, then the call will be routed through a system designed at Cisco Agent Desktop (UUCX). The routing process works in the following manner: There are seven (7) trunk lines in our system and an agent who is ready to serve requests and has the longest ready mode is the first one to answer the call; if this agent cannot answer the phone, the call will be routed to the next available agent with second longest ready mode. When an agent picks a call, two events are possible; either this agent can

handle the call while the customer is on the phone, or the contact center will require more time to resolve the customer's problem.

When a call handling time was less than 60 minutes, we assumed the customer request could be resolved while the customer was on the phone. For such calls, data was collected and the corresponding histogram created at Matlab, figure 4 shows the frequency of calls which are classified based on talk time duration. Data behavior conformed to Exponential distribution with  $\mu=10.56$  (Expo (10.56)).

```
>> ExpoDist=fitdist(TalkTime,'Exponential')  
  
ExpoDist =  
  
ExponentialDistribution  
  
Exponential distribution  
mu = 10.561 [10.032, 11.1332]
```

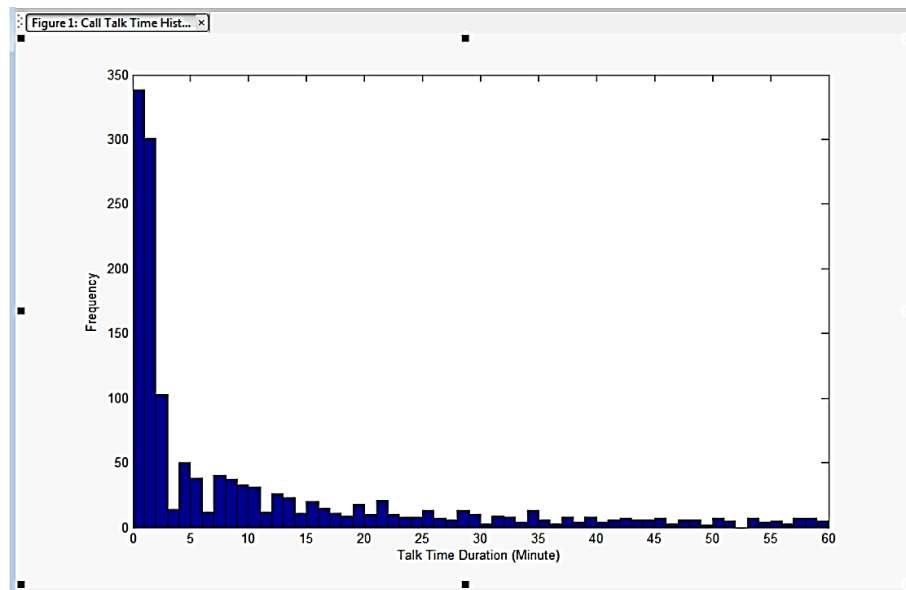

Figure 4. Talk Time Frequency

In a situation where all agents or trunk lines are busy, the customer waits in a queue for the next available agent or there is an option to send an email to the Support Desk, and that request will be handled by a FIFO policy. The Rowan approach is to serve walk-in requests immediately, and then incoming calls are addressed. Finally, the requests in the queue will be handled.

Looking at telephone request arrivals, the probability that a solution will be provided at the time and the call terminated is only 10%. Therefore, 90% of calls need further investigations, so tickets will be generated and put in the queue to be served.

Three models were created for the Rowan Support Desk. The first model reflected the current process of handling requests. The second model applied a new routing method which is the effort of this research, and the last model showed the result of the current process but by adding more experienced agents. The flow and distribution of incoming requests were the same for all the models; however, each model had its unique features resulting in different outputs. Table 3 shows the request arrival schedule featuring data extracted from the Rowan database. The “average” column depicts incoming requests per day.

Table 3  
*Request Arrival Schedule*

| Time           | Incoming Requests per Hour in a 1 Year Period | AVG Requests per Hour per Day |
|----------------|---|-------------------------------|
| 1:00am-4:00am  | 1   | 0                             |
| 5:00am-8:00am  | 786   | 2                             |
| 9:00am-12:00am | 4700  | 13                            |
| 1:00pm-4:00pm  | 3943  | 11                            |
| 5:00pm-8:00pm  | 252   | 1                             |
| 9:00pm-12:00am | 35  | 0                             |
| Total          | 9717  | 27                            |

Table 4 presents the division of incoming requests between different contact channels such as telephone calls, emails, web-forms and associated service times; note that email was the most common way to submit a request.

Table 4

| <i>Incoming Requests and Service Time</i> |                       |       |            |
|---|-----------------------|-------|------------|
| Type                                      | AVG Service Time(Hrs) | Count | Percentage |
| Email                                     | 81.53                 | 6246  | 64.3%      |
| Phone Call                                | 49.8                  | 3031  | 31.2%      |
| Web Form                                  | 110                   | 216   | 2.2%       |
| Walk in                                   | 51.2                  | 192   | 2.0%       |
| Workshop                                  | 42.9                  | 32    | 0.3%       |
| Total                                     | -                     | 9717  | 100.0%     |

### 5.3. Request Arrival Process

In order to understand the incoming request distributions, I first plotted the original data. My approach was to view a day as 1440 minutes; then I created a bar chart using Matlab software. Plotting the incoming requests helps determine the peak time of a day. Since, the support desk accepts requests through voice mail after working hours and during weekends, the center was modeled 24 hours a days, 7 days a week.

After plotting the incoming requests we tested three (3) relevant distributions to identify the most appropriate one. Cumulative distribution functions (CDF) were also graphed for comparison. The next steps presented are from Matlab software for calculating the CDF for these three different distributions, Poisson, Normal and Exponential. Below is a screen shot from Matlab software that shows the commands for finding the best distribution. These codes show fitting three different possible



distributions, Normal, Poisson and Exponential, that I tested to find the best fitted distribution to the existing data. In figure 5, there are three graphs in the chart. The most right graph shows how fitting a Poisson distribution would represent the existing data behavior. The most left graphs present the original data and behavior of fitting a Normal distribution.

```

normDist=fitdist(timeInterval,'Normal');
poisDist=fitdist(timeInterval,'Poisson');
ExpoDist=fitdist(timeInterval,'Exponential');

normX=normrnd(normDist.mu,normDist.sigma,1000,1);
normXNormal=normX/max(normX);

poisX=poissrnd(poisDist.lambda,1000,1);
poisXNormal=poisX/max(poisX);

expoX=exprnd(ExpoDist.mu,1000,1);
expXNormal=expoX/max(expoX);

X=0:.1:1;

for i=1:1:11
timeIntervalCDF(i)=length(nonzeros(timeIntervalNormal<=X(i)))/length(timeIntervalNormal);
normCDF(i)=length(nonzeros(normXNormal<=X(i)))/length(normXNormal);
poisCDF(i)=length(nonzeros(poisXNormal<=X(i)))/length(poisXNormal);
expCDF(i)=length(nonzeros(expXNormal<=X(i)))/length(expXNormal);

```

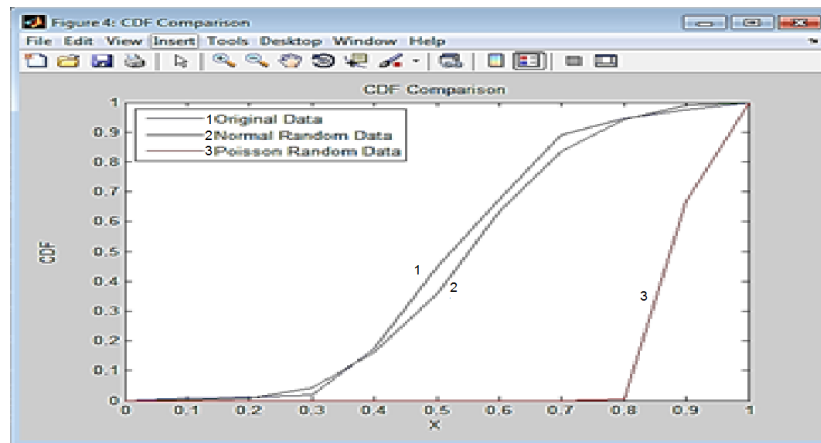

Figure 5. CDF Comparison of Intervals' Fitted Distribution

As the comparison of distributions' CDF with original data shows in figure 5, normal distribution may be the best fit for incoming requests; however, we could not specifically determine the best distribution when we separate call arrivals from the rest of the arrivals. As plotting call arrivals and other types of request arrivals show in figure 6, the call intervals have a different behavior from other intervals. We are able to fit a Normal distribution on other types of request arrivals except calls. However, a multimodal distribution is needed to cover the call arrivals trend. Therefore, it is more practical and accurate to model the arrival process by setting two separate schedules within Arena software, one for incoming calls and the other for the rest of the requests and work directly with the real data schedule not with possible fitted distributions. (The integer numbers account for average arrivals per hour of a day). The charts in figure 6 were plotted by the real data, so they explicitly present call arrival and other types of requests arrival nature.

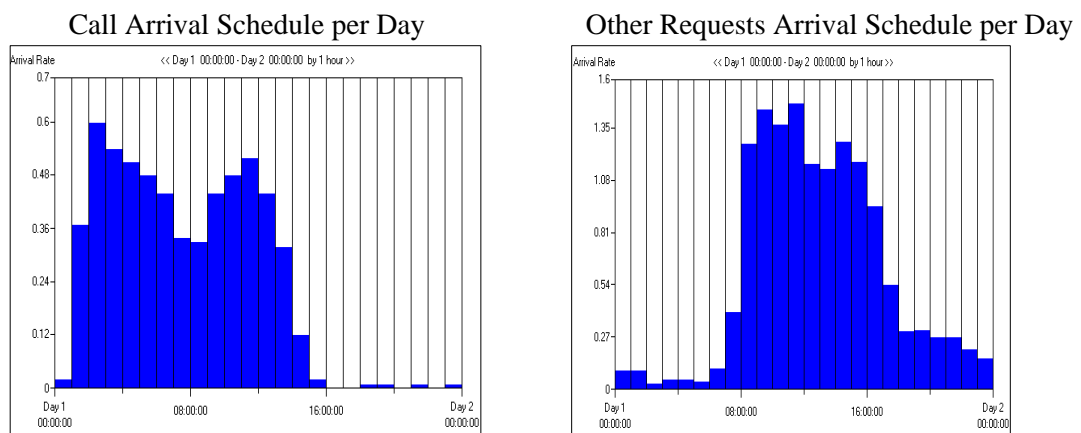

Figure 6. Intervals Schedule

## 5.4. Schematic Routing Diagram

In the following two sections, we first deliberately described the current procedure that a ticket goes through when entering to Rowan Desk system. Then, an extensive explanation of the improved proposed process is provided. Under each subsection the schematic model of the presented process is depicted.

**5.4.1. Current process.** Figure 7 on the following page is a schematic view of the current request handling process at the Rowan Support Desk. This process begins when requests arrive at the system, 31.2% of requests through phone calls and the remaining 68.8% via emails, web-forms and walk-in. When a request enters the system, the first action is to assign a priority number. Although it may seem walk-in requests have the highest priority, if meanwhile an incoming call occurs, the agent has to answer the call. So, phone calls have the highest priority, so priority number one (1), which correlates with the highest priority, and is assigned to these requests. Respectively, other incoming requests will acquire priority number two (2) that indicates “normal” priority.

When priority is assigned, the request enters the system based on the process that was outlined earlier. Then, we assume that there is a standard handling time which can be obtained by calculating the average handling time of all the agents’ performance. Thus, the standard handling time will be allocated to every individual ticket, and afterward, tickets will be assigned to agents. The ticket assignment in the current model works by totaling the number of tickets for the given academic year, determining the number of tickets that could be resolved by each agent; and calculating the associated percentage. Therefore, if agent A could handle 20% of the tickets, in the model we said the first 20%

of the tickets were assigned to this agent. If agent B performance was 10%, the ticket assignment worked as follows:

*Agent A number of assigned tickets*  $\leq 20\%$

*20% < Agent B number of assigned tickets*  $\leq 20\% + 10\% = 30\%$

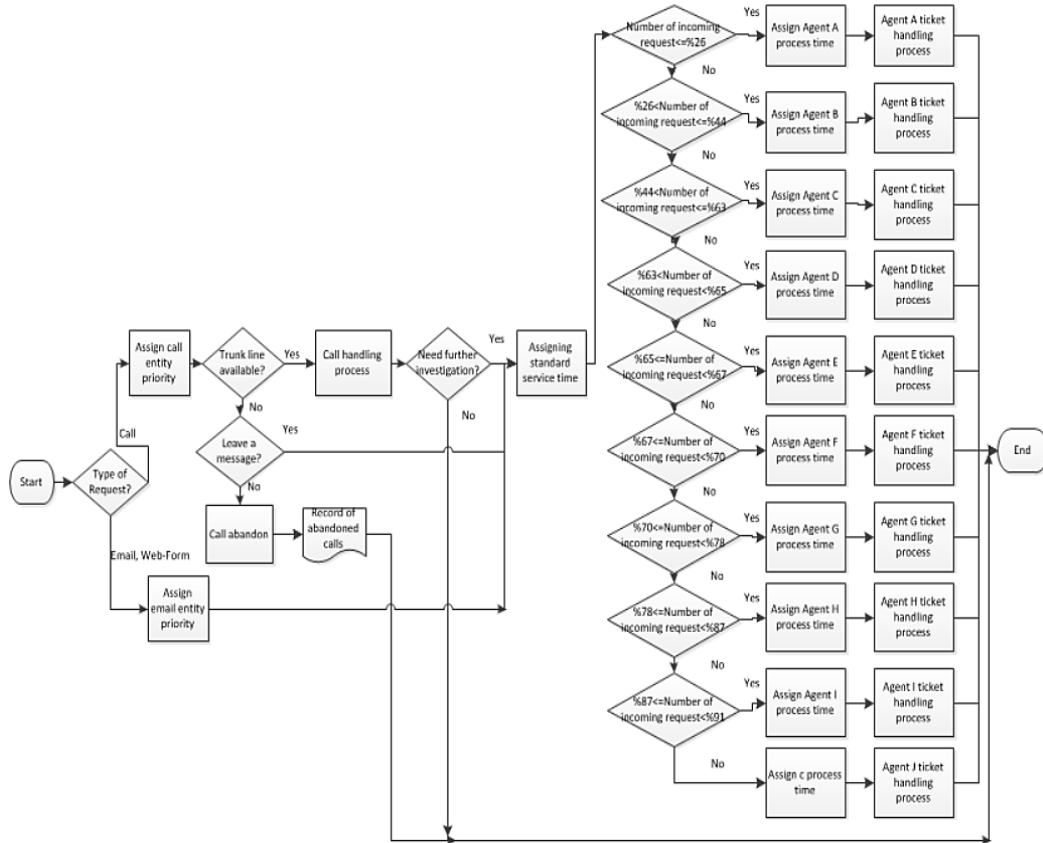

Figure 7. Current Request Handling Process Diagram

The following diagram provides a schematic presentation of the process explained above:

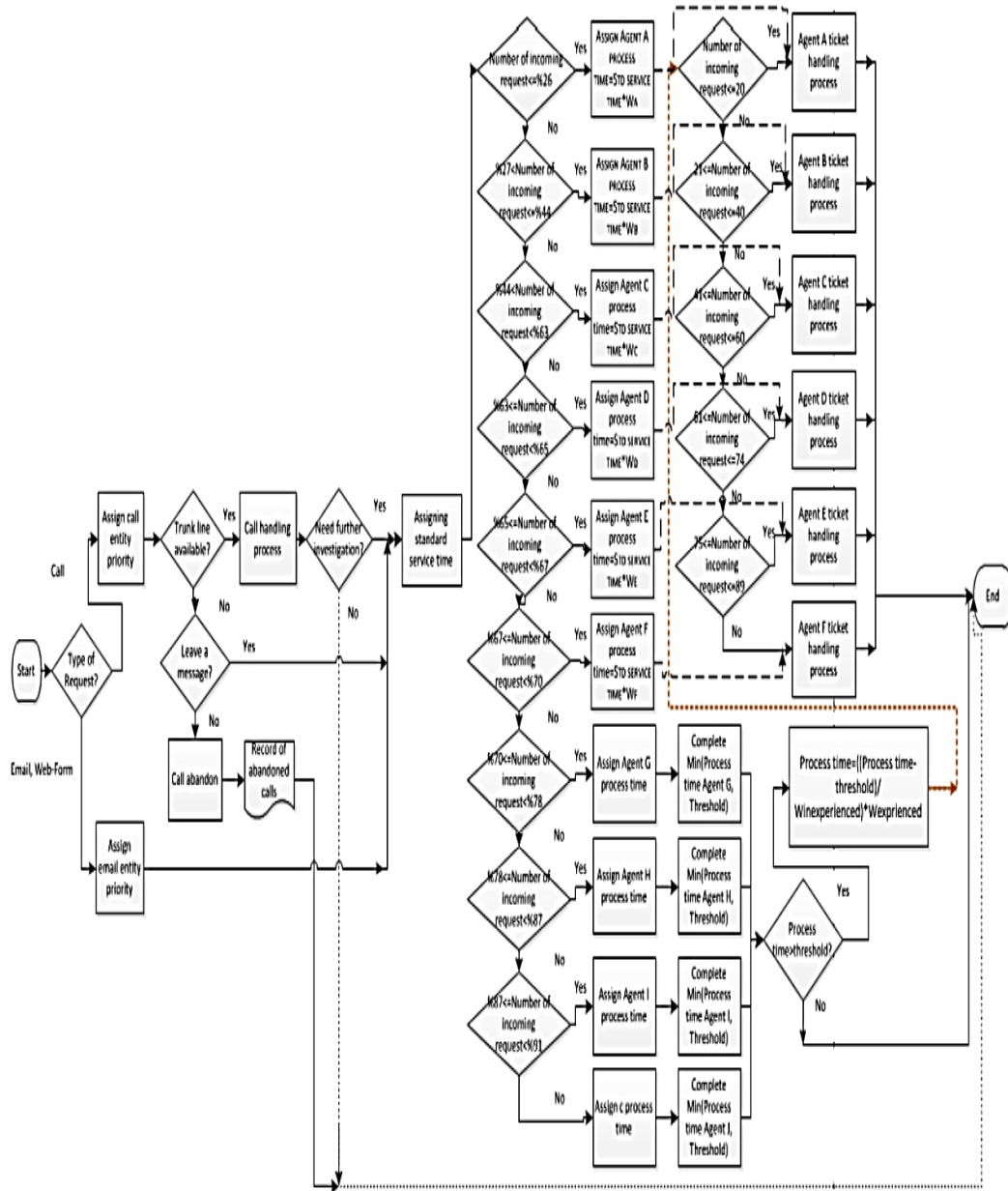

Figure 8. New Process for Handling Requests Diagram

## **Chapter 6**

### **Simulation**

In analyzing a gap between a call center existing process and ideal performance, simulation is a fundamental tool. Simulation and modeling enables us to predict possible effects of a proposed alternative and compare its efficiency with reality. Simulation results will validate what we have presupposed and help us to prove our theory efficiency (Anton, Bapat, and Halland, 2000).

#### **6.1. Implementation**

The model of this study used discrete event simulation in which the system operations are modeled as a discrete sequence of events. These events happen at specific times and make changes in the state of the system. As it is presumed that no changes occur between two events of the system, the simulation can jump from one event to the next. This feature enables users to simulate almost every process and, specifically, it is an effective method to investigate the result of business decisions before applying them in the field of business process modeling.

#### **6.2. The Simulation Model**

By using the student version of Rockwell Software's Arena, a model has been constructed and the following assumptions were adopted as part of the model:

1. Full-time agents worked 8 hours a day and they had one (1) hour lunch time. We did not consider any other breaks while they were working.
2. Talk time on calls were assumed to be Exponential distribution with  $\mu=10.6$  minute.

3. Call handling time was the total time of talk time and after call follow-up work.
4. Abandonment data were extracted by some estimation from old data, and it was given to be 10%.
5. As the support desk received voice messages and emails after working hours, we considered this center to work 24 hours a day, 7 days a week.
6. Agents and supervisors worked on back office issues such as training, and meetings when they were idle. This was not modeled in this simulation.
7. The number of trunk lines was limited to seven (7) available at the time of simulation.
8. Given the limitations of the student version of the software and in order to use the maximum capability of the software, the length of simulation replication was set at 186 hours; which is almost 7.75 days.
9. A working week started on Sunday and ended on Saturday; each working day was considered 24 hours.
10. Arrival occurs when a new request enters the system. This arrival may be in the form of a phone call or other types of incoming requests, such as, email and web-form. An arrival generates the following process:

If there is an idle trunk-line and an agent is available, the agent and the trunk-line are seized, and the request handling process will start. Otherwise, the customer is put into the queue to wait for the next available line or abandoned call. The customer also has the option of recording a message before dropping the call. The next request enters the

system based on the predefined schedule for phone calls and other arrivals.

11. Service Completion happens when an agent status changes to ready mode from a busy status, the following steps are taken:

Incoming calls have the highest priority, so the agent first answers calls if there are any available. After that, if there is a customer in the queue, the agent will start handling that customer. Requests received via email and web-form are placed in the queue and handled accordingly.

12. Abandonment is when a customer contacts via phone call, cannot reach an agent, and he chooses to leave the call before any conversation occurs.

### **6.3. Simulation Runs**

Different request intervals were scheduled for different contact methods. As mentioned earlier, to make the model simple two separate arrival processes were defined. The simulation ran for 186 hours and the relevant results were recorded. Below is a detailed description of each step of simulation, and snapshots of Arena modules are provided starting from the following page (the descriptions are for the improved process model which is more comprehensive than current process modules):



1. Two types of request arrival were modeled. a) Call arrival, b) Other arrivals. As there were no exact distributions to explain the arrival process, we exactly modeled the arrival schedules for one week.

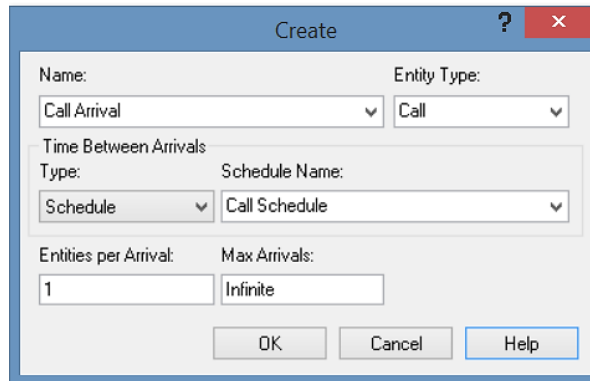

Figure 9. Arena Module (Call Arrival)

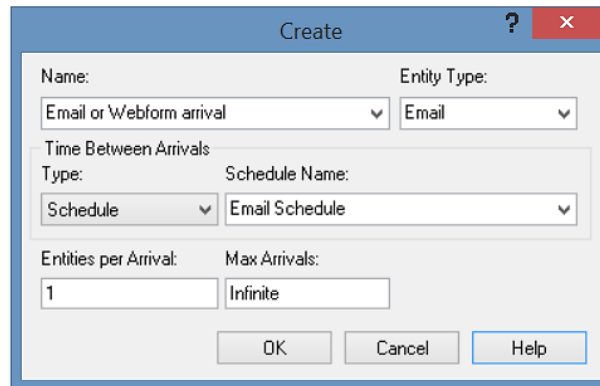

Figure 10. Arena Module (Other requests Arrival)

2. When an arrival occurred, the first action was to assign priority. Based on current performance, calls had the highest priority, so number 1 was assigned to calls. Priority number 2 was allocated to the other arrivals. Figure 11 shows how the process can be modeled using Arena software.

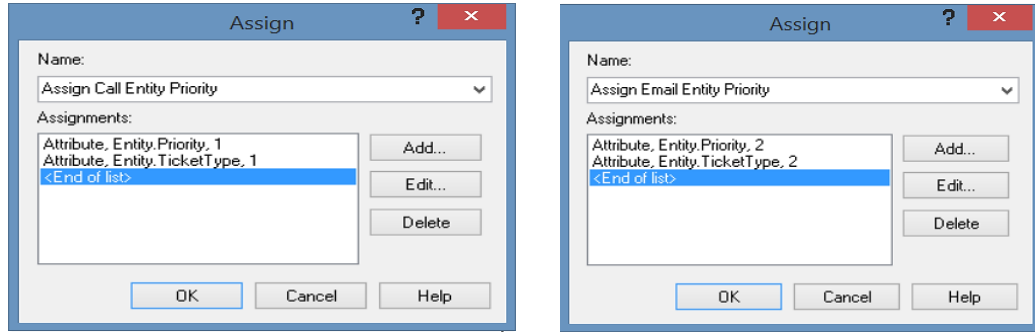

Figure 11. Arena Module (Priority Assignment)

3. The following steps explain the process of generating tickets for calls. As noted before, there were seven trunk lines available for handling customers who chose to connect to a live agent from IVR options. We included a decision module in the model to check if there was an idle trunk line available. This checking was done by a NR (Trunk Line) < MR (Trunk Line) command. NR refers to the number of trunk lines which are busy and MR shows the resource trunk lines capacity.

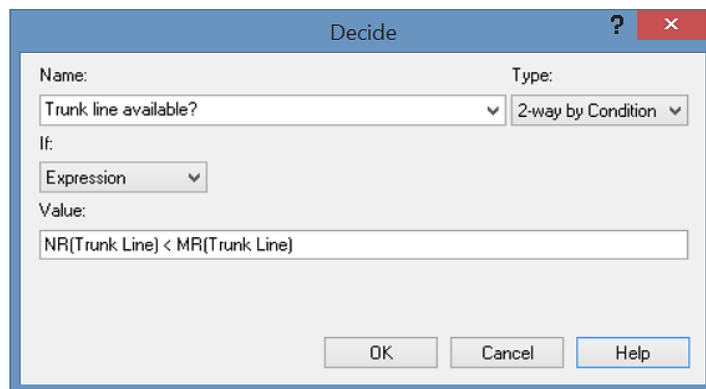

Figure 12. Arena Module (Trunk Line Availability)

i. If the capacity of trunk lines was greater than busy trunk lines, then the call would be connected to an agent. An idle agent and trunk line would be seized and the call handling process would start. The previous analysis showed call talk time has exponential distribution with  $\mu=10.6$  minute. After the conversion ended, both resources would be released.

Only about 10% of the issues would be resolved within the phone conversation, and the rest needed further investigation. So, tickets would be generated for these 90% of calls requiring follow-up.

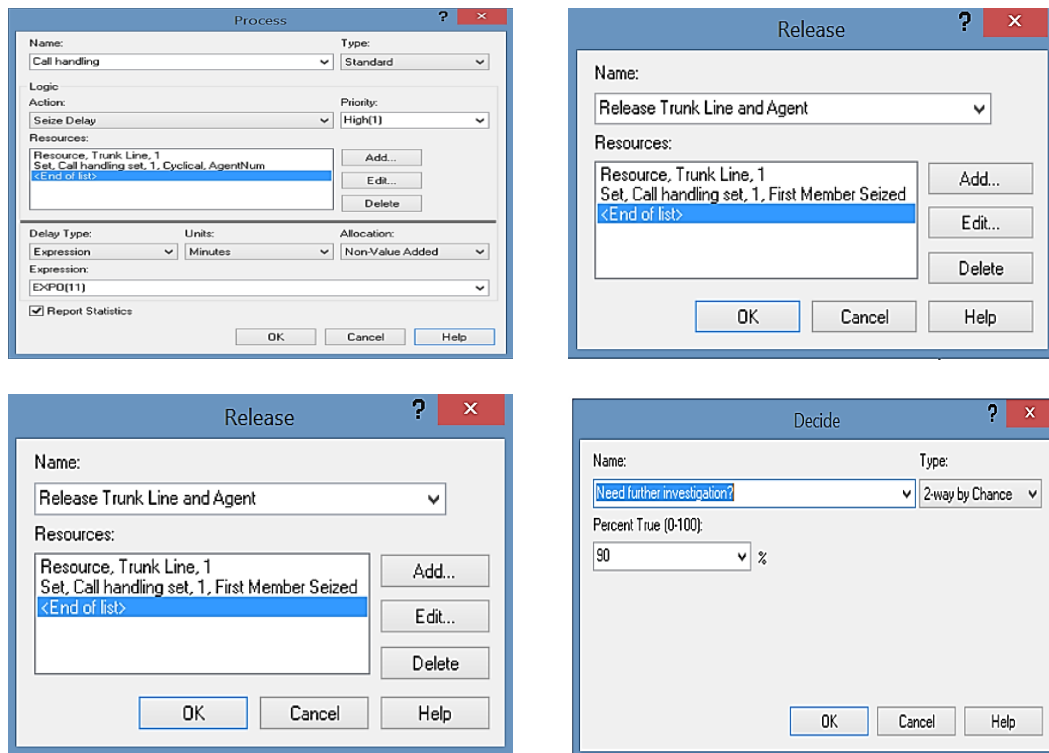

Figure 13. Arena Module (Call Handling Process)

ii. If there was no trunk line available, the customer had the option to leave a message or abandon the call. Based on data from CISCO system,

87% of callers chose to leave a message and the rest of the calls would be considered as abandoned calls. Figures 14 in the following page depict this process.

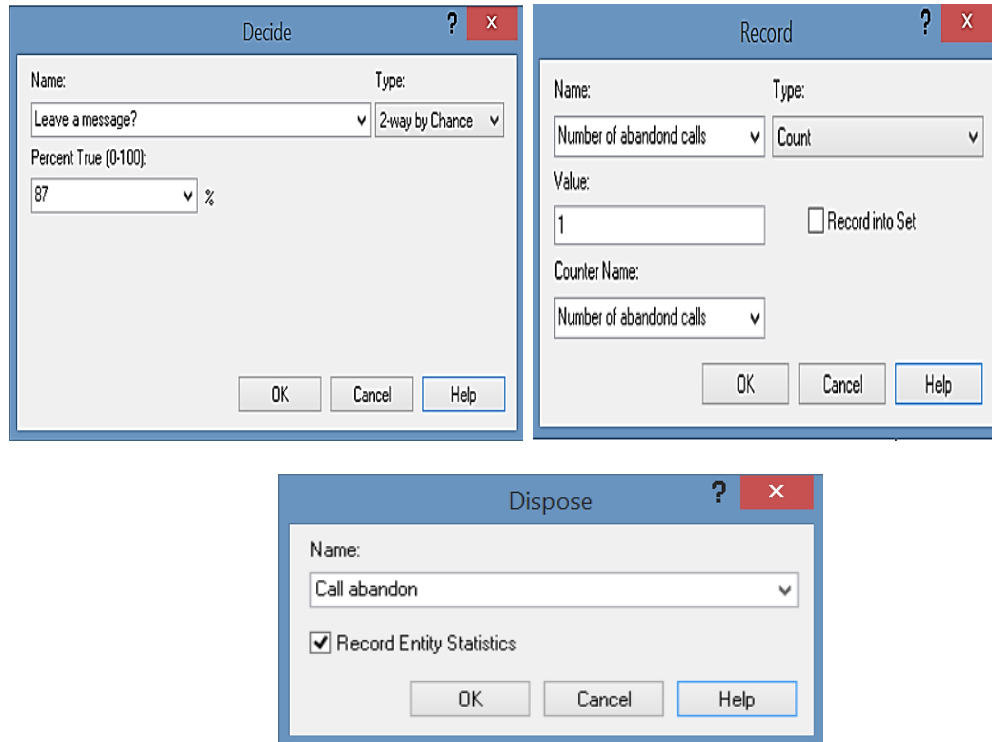

Figure 14. Arena Module (Call Abandonment)

4. In this step, tickets were generated for requests through emails and web forms; they were added to the tickets that had been generated from the last step for requests via calls. The standard handling time obtained from calculating the average handling time of all agents was assigned to every single ticket. Earlier calculation showed handling times were exponentially distributed with  $\mu = 70$  hours, which equals 2.9 days.

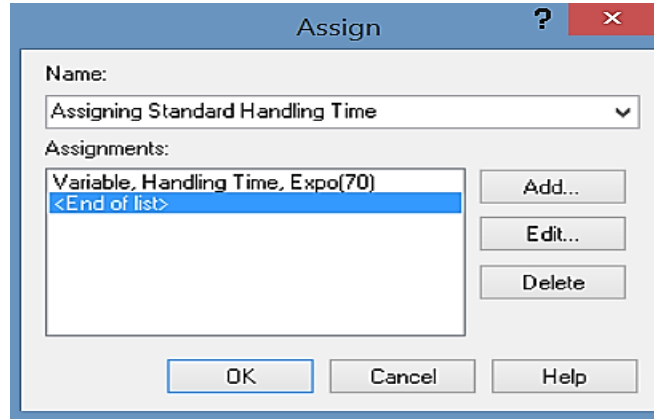

Figure 15. Arena Module (Standard Handling Time Assignment)

5. After assigning standard handling time to tickets, they were routed to agents based on the percentage of tickets that each agent could handle for the duration of our study.

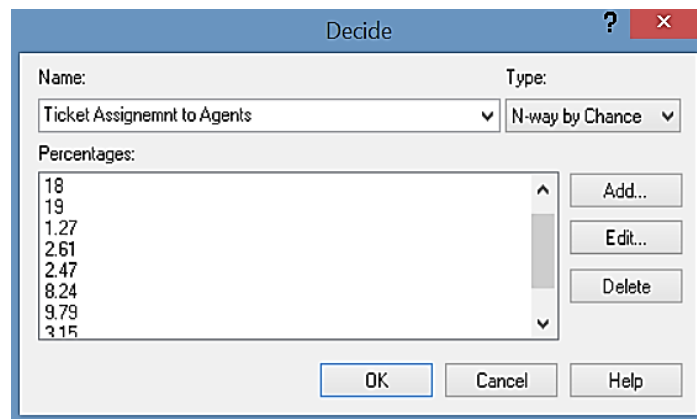

Figure 16. Arena Module (Call Routing Decision Box)

6. Imagine a ticket was assigned to agent A; in this step, agent A would start handling the ticket based on his or her own performance category. Thus, if he was a specialist, his AHT would be less than standard handling time; and conversely,

if he was a generalist, the associated AHT would be greater than standard handling time.

$$\begin{cases} \text{Agent } i \text{ handling time} = W_i \times \text{standard handling time} \\ W_i > 1 \\ W_i \leq 1 \end{cases} \begin{array}{l} \text{for Generalists} \\ \text{for Specialists} \end{array}$$

Agent A handling time would be allocated to the ticket, and the ticket would be processed.

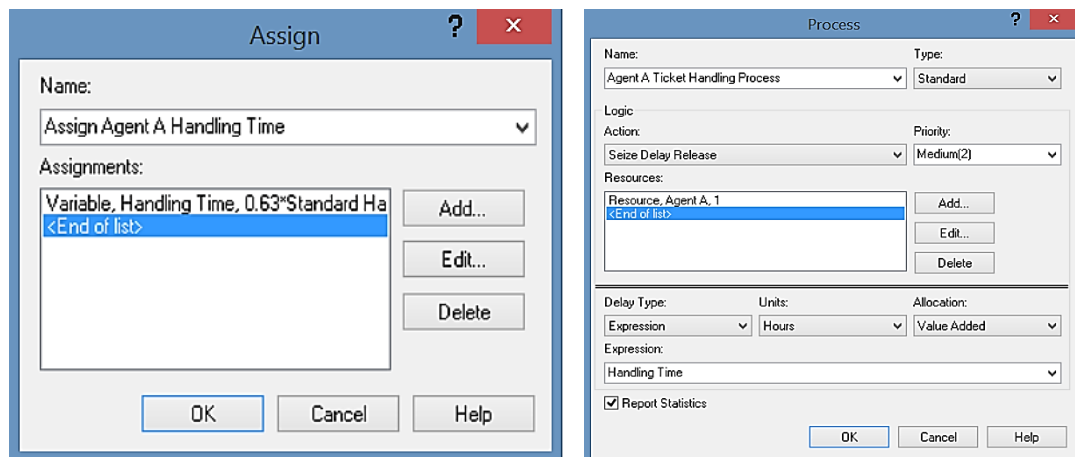

Figure 17. Arena Module (Specialists Group Handling Time Assignment)

7. In both current and increased staff models, tickets remained with the agents until they could resolve issues. However, in the proposed process, tickets assigned to generalists were monitored, and if agents could not resolve them within the desired threshold, the ticket was reassigned. In the reassignment process, only generalists were in charge of picking the ticket. Assume agent B is a generalist. As such, his handling time will be as follows:

$$\text{Generalist } i \text{ handling time} = \text{Min}(\text{threshold}, \text{Generalist } i \text{ handling time})$$

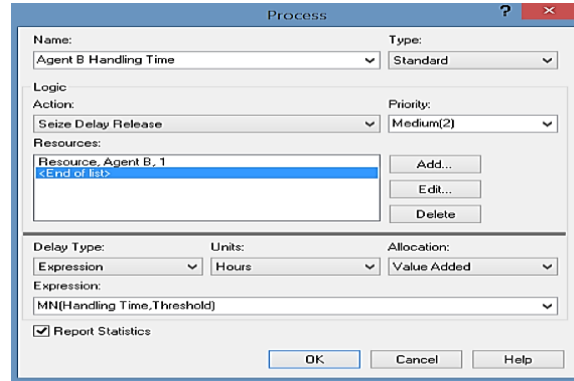

Figure 18. Arena Module (Generalist Group Handling Time Assignment)

8. In the model, there was a decision module to check handling time, and if the generalist's handling time was greater than the predefined threshold, the ticket was reassigned. This reassignment was similar to the first ticket assignment; however, in this step there were six (6) specialists of the total 10 agents. So, tickets were distributed among these six agents.

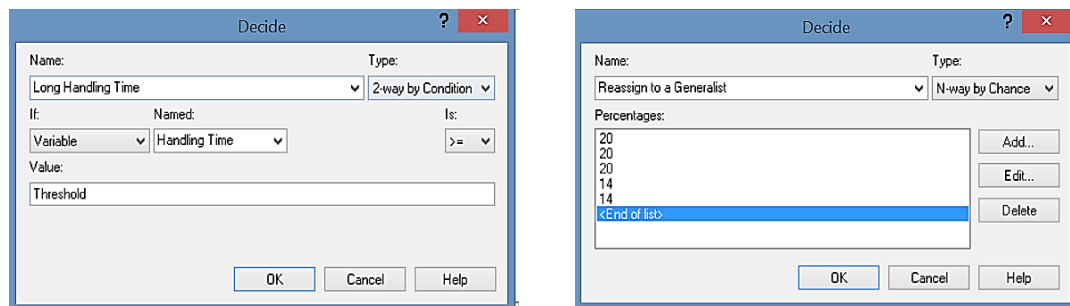

Figure 19. Arena Module (Long Handling Time Checking)

In this phase, a specialist resumed ticket processing, and handling time in this step was obviously less than the first ticket assignment because part of the handling process had already been done by a generalist. But, since these two groups of agents

had different performances, the remaining handling time was calculated through the following formula:

$$\text{Remaining Handling Time} = \frac{\text{Standard handling time} - \text{threshold}}{w_g} \times w_s$$

$w_g$  → *wieght of generalist's performance*

$w_s$  → *weight of specialist's performance*

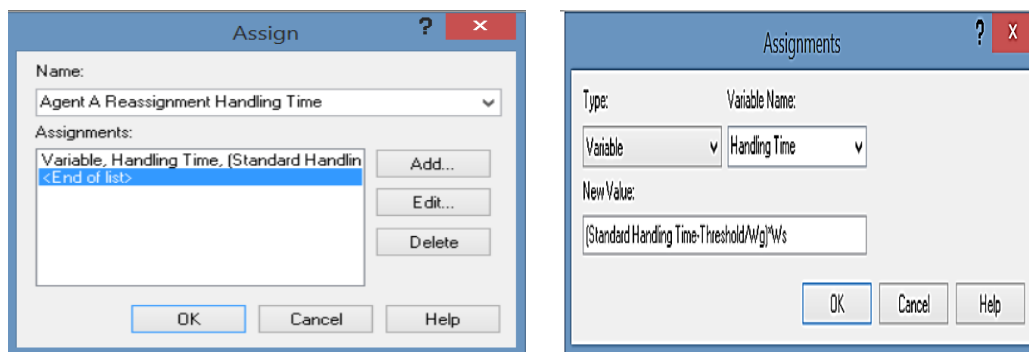

Figure 20. Arena Module (Tickets Reassignment Process)

After the reassignment, the ticket process was continued by an experienced agent until it could be solved and the ticket was closed. Below is a list of metrics that are the main outputs of the simulation:

- Total number of intervals (dividing by different contact channels) and total number of answered calls;
- Abandonment rates;
- Average wait time in the system and average total time in the system (Includes waiting time, talk time, after-call follow-up);
- Agent average performance and utilization.



#### **6.4. Some Specific Design Issues**

It is important to review here some specific design issues faced when simulating the Rowan Support Desk.

1. Software limitation: An error popped up while the model was being run, indicating that “Maximum of 150 entities exceeded.” This warning occurs when an academic version of the software is used and a model exceeds the demo version’s entities limit. Actually, a model generated many entities when, in our example, requests were waiting for agents to be handled or too many entities were being generated. Facing this error forced us to limit the number of the model’s entities. Thus, it was assumed that service times were assigned later in the model rather than in the first step.
2. Another problem in creating the model was lack of detailed abandonment rate data. However, since the proposed process performed similar to the existing process in the first steps, we can claim no change impacted abandonment by adopting the new process.
3. Moreover, lack of data about ticket assignment policy created more randomness in the modeling. It made us fill the ticket assignment decision box based on agents’ past performance and percentage of tickets that every agent handled during the period of simulation.

## Chapter 7

### Results and Conclusion

#### 7.1. Results

The results presented here were collected from the utilized simulation software. We created three models and to prevent facing the student version limitation, each model was replicated just once and the time period we used for our analysis was 186 hours which is equal to 7 days and 17 hours. In all models, the support desk operation was considered 24 hours a day and 7 days a week.

A range of different thresholds was tested to find the optimum time for reassigning tickets from generalists to specialists. The outputs of each replication were gathered directly from Arena software's reports. The following table summarizes the results of metrics being assessed for threshold range [55-85] hours, increased by 5 hours.

Table 5

*Analysis of Proposed Process Performance*

| Threshold | Intervals | Solved Tickets | %Solved Tickets | AVG Handling Time |
|-----------|-----------|----------------|-----------------|-------------------|
| 55 hrs    | 155       | 55             | 35%             | 60.09             |
| 60 hrs    | 181       | 48             | 27%             | 50.29             |
| 65 hrs    | 161       | 69             | 43%             | 58.01             |
| 70 hrs    | 149       | 50             | 34%             | 58.2              |
| 75 hrs    | 164       | 52             | 32%             | 65.63             |
| 80 hrs    | 177       | 50             | 28%             | 61.09             |
| 85 hrs    | 173       | 47             | 27%             | 68.6              |

Figure (21) displays AHT changes in response to set different thresholds. As observed, minimum AHT is associated with threshold=60 hours; the second lowest AHT is obtained by setting threshold to 65 hours.

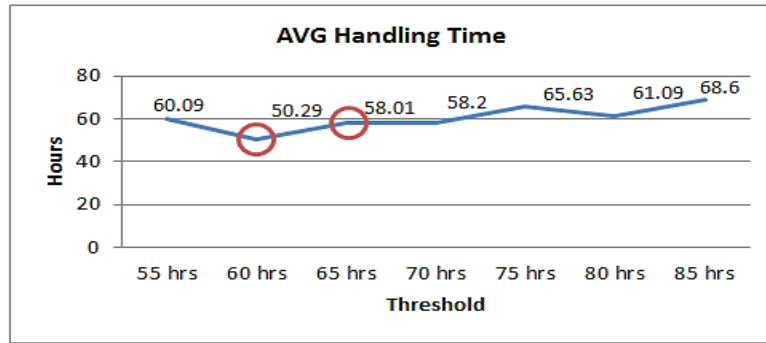

Figure 21. Proposed Process Performance Analysis; AHT

Total number of resolved tickets is another influential factor in determining the optimum threshold; figure (22) depicts how this factor is varied in response to a different reassignment time. Similar to figure (21), two circles, 65 and 60 hours, in the following figure show the thresholds relevant to maximum total number of resolved tickets.

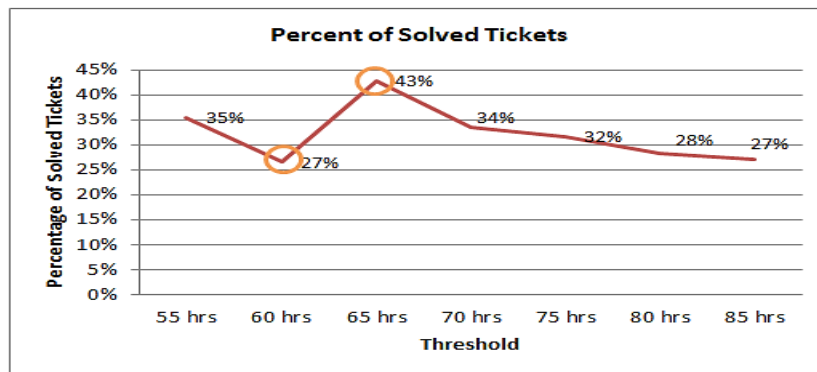

Figure 22. Proposed Process Performance Analysis; Percent of Solved Tickets

In the case of the Rowan Support Desk, setting threshold either to 60 hours or 65 hours will result in a minimum AHT and maximum number of resolved tickets respectively. Outputs of these two thresholds are highlighted in table (5).

The following table presents the simulation results for all three models, including the current process. It is obvious that acquiring more professional agents will improve the support desk performance; moreover, as can be seen, applying the new process enhances current performance in both percent of tickets resolved and average handling time. Average time in the system, which is equal to average handling time, was reduced from 61.1 hours to 58 hours. This reduction means an 8% improvement in average handling time of tickets.

Table 6

*Performance Analysis of Three Models*

| Model                   | Intervals | Solved Tickets | %Solved Tickets | AHT   |
|-------------------------|-----------|----------------|-----------------|-------|
| Existing Model          | 171       | 46             | 27%             | 61.1  |
| Efficient Process Model | 161       | 69             | 43%             | 58.01 |
| Add 3 Agents Model      | 171       | 53             | 31%             | 47.89 |

Considering table (6) data and comparing the outputs of the models, we can claim the following achievements:

- By applying a new process of handling requests and modifying routing policy:
  1. There is a 16% increase in the total number of resolved tickets;

2. Average handling time has decreased to 58.01 hours from 61.1 (for a replication length of 186 hours), and it has provided an 8% improvement.

- By considering the second alternative, and adding three experienced agents, we have reached the following results:

1. There is a 4% increase in the total number of resolved tickets;

2. And, a 22% reduction in average handling time (AHT will reduce to 47.89 hours from 61.1 by hiring more specialists).

## **7.2. Recommended Considerations**

In order to address other issues and improvements at the Rowan Support Desk, our research suggests that:

- To make the customer request clearer, the support desk should use a web form to collect essential information of those clients with requests.
- To reduce the support desk workload, the contact center should inform clients regularly about issues such as times when the system is down and network problems by public announcements.
- To overcome system complexity issues, Rowan University should consider replacing the present call center system with more user friendly versions of call center software.
- To mitigate the issues associated with the time-consuming troubleshooting process and lack of communication between departments, it is recommended that Rowan assign a contact person in each department.

- To increase staff knowledge and upgrade employee performance, Rowan should implement a professional training program.
- Rowan should offer performance incentives to call center personnel.

### **7.3. Conclusion**

This research evaluated the Rowan Support Desk performance from two different perspectives; first, by adding three additional specialists and, second, by modeling a new process for handling tickets. The performance analyses were done using Arena simulation software.

In this thesis, a modified process for handling tickets at a call center was studied. The call center considered in this study is Rowan University support desk assisting Rowan employees and students with all their computer and telecommunication concerns such as computer software and hardware, mobile devices, email, printing, access to network services, network accounts, and all aspects of telecommunications issues. At this center the large number of incoming requests, more than 71%, that takes more than 72 hours to be solved caused users' dissatisfaction. This issue was the main inspiration for conducting this study and proposing a new improved process for handling tickets. Rowan Support Desk performance were evaluated by modeling two different scenarios; first, by adding three additional specialists and, second, by modeling a new process for handling tickets. The performance analyses were done using Arena simulation software.

The results of this research study reveal that applying a modified process for reassigning tickets after a predefined threshold, which was set to 60 hours, is more efficient than the existing process. Tickets reassignment provided us with a **16%** increase in the total number of resolved tickets, and a 8% decrease in Average Handling Time.

The main reason for this achievement is the difference in agents' performance, skills and expertise. This study provides the evidence that reassigning tickets after a desired threshold will improve AHT and the total number of resolved tickets significantly. Furthermore, this approach does not require any changes in the current technical system or operating costs increase.

Moreover, the analysis of the second scenario showed that by hiring 3 more specialists, Rowan support desk can achieve a 4% increase in the total number of resolved tickets, and a 22% reduction in average handling time. However, Rowan is required to allocate sufficient budget to conduct this solution.

It is noteworthy that these conclusions are confirmed from the results in previous chapters. The outcomes of this research have clearly provided an effective solution for the Rowan Support Desk managers which can also be developed, implemented and analyzed by other similar contact centers.

Therefore, the Rowan University Support Desk managers can now consider alternating between applying the new modified process or hiring more agents, obviously at the cost of their salaries and training.

#### 7.4. Future Research

In this section some directions worthy of further research are explained.

- Including real data of abandonment in modeling call centers: Current models of contact centers' performance suffer from insufficient data to take abandonment into account. It was the case for this study as well, and it forced us to estimate this indicator by using the past data. By introducing Erlang-A formula Garnett, Mandelbaum, and Reiman (2002) tried to include patience time; their suggestion is to allocate a random number to each arriving call based on nature of patience time which is exponentially distributed. Quality of abandonment which is a function of time makes its rate varies at different time intervals due to agents' work load. Therefore assigning random number to this indicator will decrease the validity of the final results.
- Widening scope of the research: The model of this study focused on support desk area of responsibility. As lack of communication between different departments was one of the identified issues, a research can be done to widen the scope of projects and include all the other relevant departments. For the purpose of improving performance, one may study the results of expanding the scope of the research and assigning a contact point in every department, to log possible changes and inform other unites.
- Route the requests first to specialists and then generalists: In the models of this study, we assumed requests were assigned to the agents randomly. Actually, our approach was to calculate the fraction of requests that an agent could handle, then in the decision box of Arena we assumed that a proportion of requests would



be handled by, for example, agent A. However, for the purpose of improving the current process, we can apply a routing algorithm to route the requests first to specialists and then generalists. In this situation, there will be fewer tickets required for rerouting to an experienced agent, and thus, AHT and the number of resolved tickets will improve significantly.

- Study the effect of motivation plan on agents' efficiency: Variance in agents' performance was the main reason for proposing the improved process. Qualitative data analysis and the result of surveys, which were explained in chapter 4, directed us to assume different level of experience is the logic for the variance in agents' performance. Nonetheless, this study did not analyze effects of other factors on performance contrast. One influential element is staff motivations. When the level of motivations differs people do not perform the same. So, conducting a new incentive plan and study the related results on agents' motivation are another direction to expand this field of research.
- Monitoring percentage of work done: Another element that can be monitored for reassigning tickets is the percentage of work that a specialist can complete. This step will help us to address the issues of limited accessible hours of student workers. Therefore, if monitoring the percentage of work done shows any inconsistency with the plan, the ticket may be reassigned to the specialist group for further actions.

## References

1. Palm, Rudolf Conrad Agaton. Research on telephone traffic carried by full availability groups. Tele, 1957.
2. Cooper, Robert B. "Introduction to queueing theory." (1972).
3. Kleinrock, Leonard. Queuing systems. Wiley, 1975.
4. Gable, Robert Allen. Inbound call centers: design, implementation, and management. Boston, London: Artech House, 1993.
5. Brigandi, Anthony J., et al. "AT&T's call processing simulator (CAPS) operational design for inbound call centers." Interfaces 24.1 (1994): 6-28.
6. Iyengar, Shanto. "Framing responsibility for political issues." The Annals of the American Academy of Political and Social Science (1996): 59-70.
7. Klungle, Roger, and J. Maluchnik. "The role of simulation in call center management." MSUG Conference. 1997.
8. Bapat, Vivek, and Eddie B. Pruitte Jr. "Using simulation in call centers." Simulation Conference Proceedings, 1998. Winter. Vol. 2. IEEE, 1998.
9. Mason, A.J., D.M. Ryan and D.M. Panton. "Integrated simulation, heuristic and optimization approaches to staff scheduling", Operations Research Conference, 1998.
10. Jon Anton, Vivek Bapat, and Bill Hall. Call center performance enhancement using simulation and modeling. Purdue University Press, 1999.
11. Whitt, Ward. "Dynamic staffing in a telephone call center aiming to immediately answer all calls". Operations Research Conference, 1999.
12. Bodin, Madeline, and Keith Dawson. "The call center dictionary." New York (1999).
13. Feinberg, Richard A., et al. "Operational determinants of caller satisfaction in the call center." International Journal of Service Industry Management 11.2 (2000): 131-141.
14. Ridley, A. "Performance optimization of a telecommunication call center.". Proceedings of the Applied Telecommunication Symposium, CA, USA, 2000.
15. Anton, Jon, and David Gustin. Call Center Benchmarking: "How Good is good Enough". Purdue University Press, 2000.

16. Saltzman, Robert M., and Vijay Mehrotra. "A call center uses simulation to drive strategic change." *Interfaces* 31.3 (2001): 87-101.
17. Brady, Michael K., and J. Joseph Cronin Jr. "Some new thoughts on conceptualizing perceived service quality: a hierarchical approach." *Journal of marketing* 65.3 (2001): 34-49.
18. Gans, Noah, Ger Koole, and Avishai Mandelbaum. "Telephone call centers: Tutorial, review, and research prospects." *Manufacturing & Service Operations Management* 5.2 (2003): 79-141.
19. Stolletz, Raik. *Performance analysis and optimization of inbound call centers*. Springer, 2003.
20. Avramidis, Athanassios N., Alexandre Deslauriers, and Pierre L'Ecuyer. "Modeling daily arrivals to a telephone call center." *Management Science* 50.7 (2004): 896-908.
21. Armony, Mor, and Avishai Mandelbaum. "Design, staffing and control of large service systems: The case of a single customer class and multiple server types." *Draft 28* (2004): 271-289.
22. Koole, G. "The Calculus of Call Center: Server Level Definitions and computations." *MSON Conference*. Endhoven. Vrije Universiteit Amsterdam. 2004.
23. Mandelbaum, Avishai, and Sergey Zeltyn. "The Palm/Erlang-a queue, with applications to call centers." *Faculty of Industrial Engineering & Management, Technion, Haifa, Israel* (2005).
24. Avramidis, Athanassios N., and Pierre L'Ecuyer. "Modeling and simulation of call centers." *Simulation Conference, 2005 Proceedings of the Winter*. IEEE, 2005.
25. Norman, Kerstin. "Call center work: characteristics, physical, and psychosocial exposure, and health related outcomes." (2005).
26. Robbins, Thomas R., Deborah J. Medeiros, and Paul Dum. "Evaluating arrival rate uncertainty in call centers." *Simulation Conference, 2006. WSC 06. Proceedings of the Winter*. IEEE, 2006.
27. Koole, Ger, and Auke Pot. "An overview of routing and staffing algorithms in multi-skill customer contact centers." *Submitted for publication* (2006).
28. L'Ecuyer, Pierre. "Modeling and optimization problems in contact centers." "Quantitative Evaluation of Systems, 2006. QEST 2006. Third International Conference on." IEEE, 2006.
29. SQM, GC. "First Call Resolution Revisited: Why it still matters most, and how to improve it." *Industry Reports* (2007).

30. Aberdeen Group Report. ““Underpinnings of Service Excellence: Synchronizing Resource Capacity with Service Demand.” Industry Reports (2007).
31. Jaiswal, Anand Kumar. "Customer satisfaction and service quality measurement in Indian call centres." *Managing Service Quality* 18.4 (2008): 405-416.
32. Bocklund, Lori, and Hinton, Brian. “Cost structure and distribution in today’s contact centers” *Strategic Contact Incorporation Reports* (2008).
33. Avramidis, Athanassios N., et al. "Simulation-based optimization of agent scheduling in multiskill call centers." (2008).
34. Franzese, Luiz Augusto G., et al. "Comparison of call center models." *Winter Simulation Conference. Winter Simulation Conference, 2009.*
35. North American Quitline Consortium. “Call Center Metrics: Fundamentals of Call Center Staffing and Technologies” *NAQC Issue Paper* (2010).
36. Ali III, Louis Franklin. "A call center simulation study: Comparing the reliability of cross-trained agents to specialized agents." (2010).
37. Akhtar, Salman, and Muhammad Latif. "Exploiting Simulation for Call Centre Optimization." *Proceedings of the World Congress of Engineering. Vol. 3. 2010.*
38. Niu, Qing, et al. "Performance analysis of the operating room using simulation. “Proceedings of the Canadian Engineering Education Association (2011).
39. Deloitte Consulting. “2013 Global Contact Center Survey Results” *Deloitte Reports* (2013)
40. Bouzada, Marco Aurélio Carino. "Dimensioning a Call Center: Simulation or Queue Theory?" *Journal of Operations and Supply Chain Management* 2.2 (2013): 34-46.

## **Appendix A**

### **Definition of Terms**

In this section, a list of commonly used words in a call center is provided. Some definitions were obtained from (Bodin & Dawson, 1999):

**Key Performance Indicator (KPI)** – These indicators measure performance. An organization can assess its success or failure by monitoring specific predefined KPIs.

**Abandoned call** – Abandonment occurs when an incoming call terminates before answering by an agent.

**Automatic Call Distributer (ACD)** – When a call reaches ACD, it will be queued in a waiting line based on a predefined order. Calls are ordered by first in, first out (FIFO) and presented to the agent who has been idle the longest.

**After Call Work (ACW)** – The work done by an agent relevant to the current call after ending the conversation with a customer.

**Agent** – A person who is in charge of handling incoming calls and requests, also referred to as an operator or customer service representative (CSR).

**Average Handling Time (AHT)** – The average time an agent spends working on a call.

**Average Speed of Answer (ASA)** – The average amount of time a caller waits on hold before the call is answered by an agent

**Average Talk Time (ATT)** – The average conversation time an agent spends talking to a caller, starting from when the caller reaches an agent until the call is ended.

Interactive Voice Response (IVR) – An interactive telephone system used to facilitate the routing of incoming calls. Customers can access their desired answer or departments by following the IVR dialogue.

Peak Hour(s) – Defined as the time period when the numbers of incoming are at the highest level.

Skills-Based Routing – A method of routing incoming calls to a queue by matching calls to the type of skills required to handle the call.

Trunk Lines – Number of available trunk determines how many callers are able to get into the call center whether it's directly to an agent or through the call center's IVR.

## Appendix B

### Created Models in Arena Software

The following screen shots were captured from Arena software while the replications were run for each of the three models. The detail of how each model works was explained earlier in chapter 5.

#### 1- Existing Process Model at Rowan Support Desk

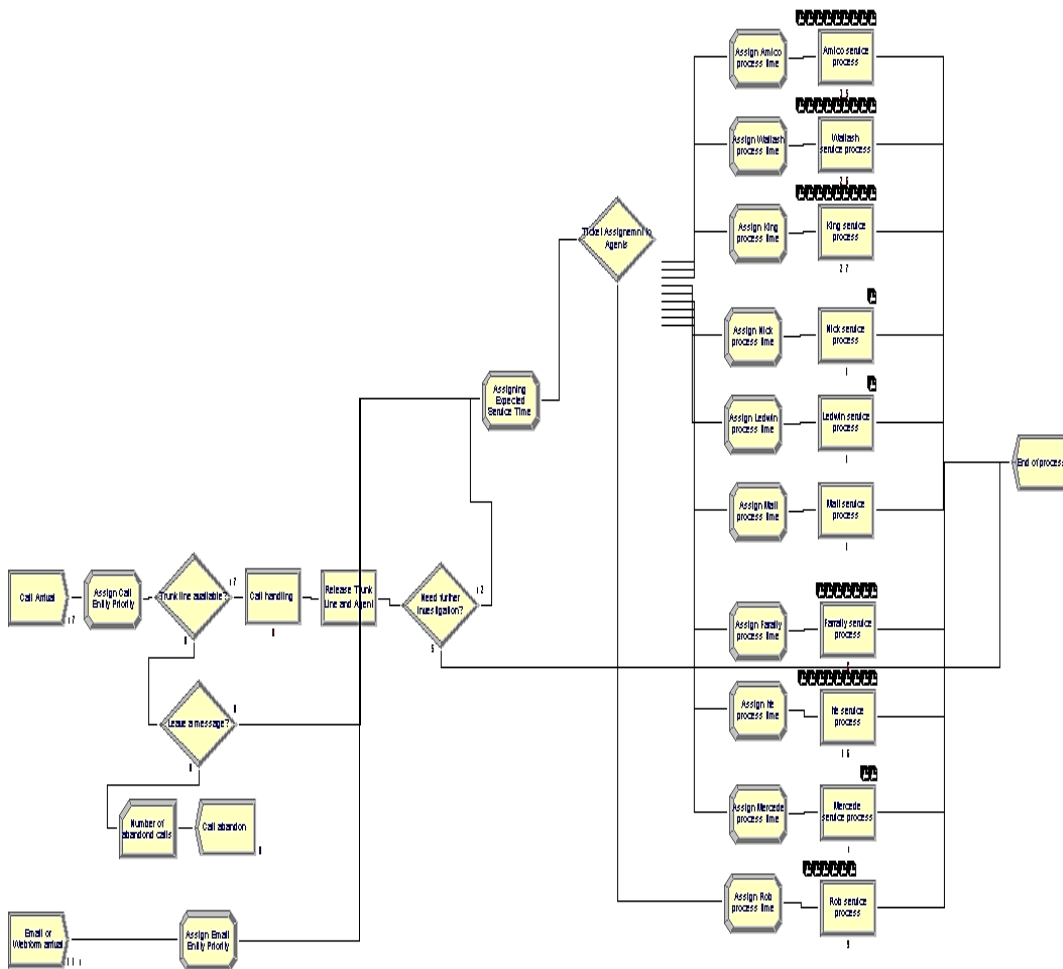

Figure 23: Arena Diagram; Current Process

## 2- Alternative Process Model-Modified Ticket Handling Procedure

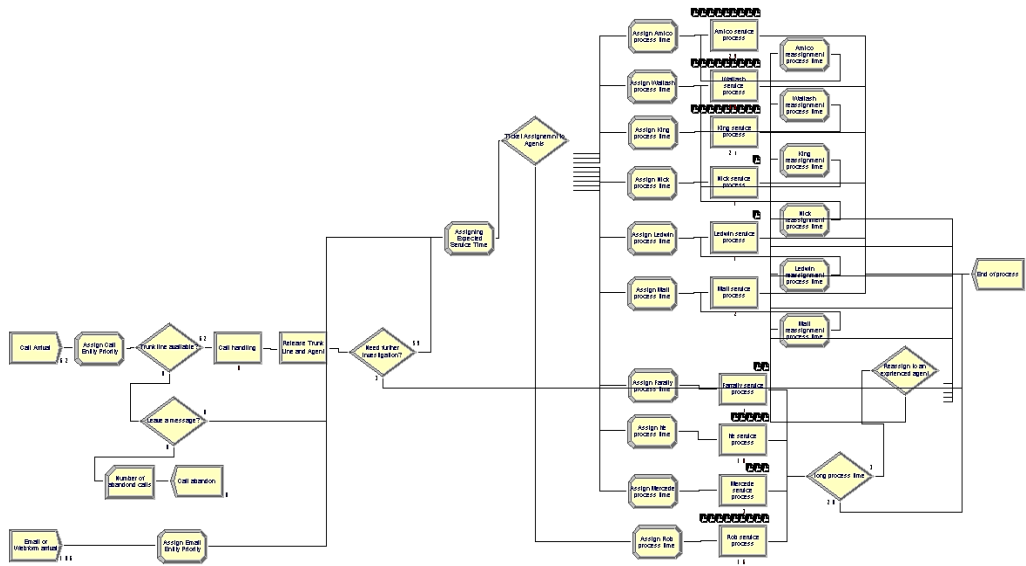

Figure 24. Arena Diagram; Proposed Process

## 3- Alternative Process Model- Acquiring More Agents

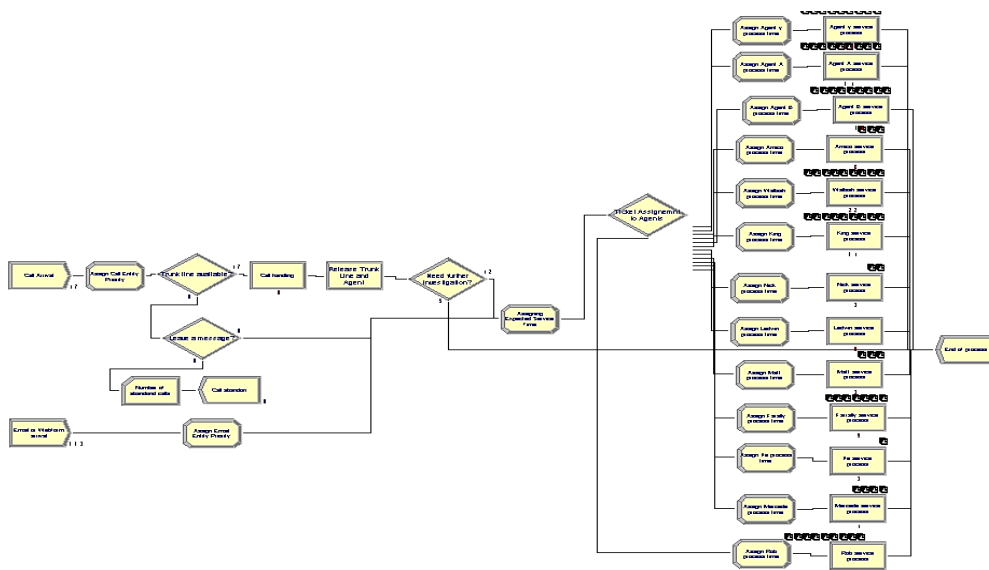

Figure 25. Arena Diagram; Add More Agents Process