

1. Report No. FHWA/TX-10/0-6384-1		2. Government Accession No.		3. Recipient's Catalog No.	
4. Title and Subtitle ON-GOING EVALUATION OF TRAFFIC CONTROL DEVICES				5. Report Date November 2009 Published: September 2010	
				6. Performing Organization Code	
7. Author(s) Paul Carlson, Roger Bligh, Adam Pike, Jeff Miles, Wanda Menges, and Susan Paulus				8. Performing Organization Report No. Report 0-6384-1	
9. Performing Organization Name and Address Texas Transportation Institute The Texas A&M University System College Station, Texas 77843-3135				10. Work Unit No. (TRAIS)	
				11. Contract or Grant No. Project 0-6384	
12. Sponsoring Agency Name and Address Texas Department of Transportation Research and Technology Implementation Office P.O. Box 5080 Austin, Texas 78763-5080				13. Type of Report and Period Covered Technical Report: September 2008–August 2009	
				14. Sponsoring Agency Code	
15. Supplementary Notes Project performed in cooperation with the Texas Department of Transportation and the Federal Highway Administration. Project Title: Evaluation and Development of Traffic Control Devices URL: <a href="http://tti.tamu.edu/documents/0-6384-1.pdf">http://tti.tamu.edu/documents/0-6384-1.pdf</a>					
16. Abstract This project was established to provide a means of conducting small-scale research activities on an as needed basis so that the results could be available within months of starting the specific research. This report summarizes the small-scale research activities that were conducted between September 2008 and August 2009. There were four primary activities and two secondary activities. The four primary activities were: developing a temporary sign support with cross bracing, providing technical support on an AASHTO retroreflective sign sheeting material specification, conducting human factors research on sign sheeting materials, and monitoring lead-free pavement marking test deck performance. In addition, the researchers also provided support for hurricane evacuation routing and started a research activity focused on identifying traffic signs with supplemental light emitting diodes (LEDs).					
17. Key Words Traffic Control Devices, Retroreflective Sign Sheeting, Hurricane Evacuation, Pavement Marking, Crash Test, Temporary Sign Support			18. Distribution Statement No restrictions. This document is available to the public through NTIS: National Technical Information Service Springfield, Virginia 22161 <a href="http://www.ntis.gov">http://www.ntis.gov</a>		
19. Security Classif.(of this report) Unclassified		20. Security Classif.(of this page) Unclassified		21. No. of Pages 134	22. Price



# **ON-GOING EVALUATION OF TRAFFIC CONTROL DEVICES**

by

Paul J. Carlson, Research Engineer  
Texas Transportation Institute

Roger Bligh, Research Engineer  
Texas Transportation Institute

Adam Pike, Associate Transportation Researcher  
Texas Transportation Institute

Jeff Miles, Assistant Research Engineer  
Texas Transportation Institute

Wanda Menges, Research Specialist  
Texas Transportation Institute

and

Susan Paulus, Graduate Student Worker  
Texas Transportation Institute

Report 0-6384-1

Project 0-6384

Project Title: Evaluation and Development of Traffic Control Devices

Performed in cooperation with the  
Texas Department of Transportation  
and the  
Federal Highway Administration

November 2009

Published: September 2010

TEXAS TRANSPORTATION INSTITUTE  
The Texas A&M University System  
College Station, Texas 77843-3135



## **DISCLAIMER**

This research was performed in cooperation with the Texas Department of Transportation (TxDOT) and the Federal Highway Administration (FHWA). The contents of this report reflect the views of the authors, who are responsible for the facts and the accuracy of the data presented herein. The contents do not necessarily reflect the official view or policies of the FHWA or TxDOT. This report does not constitute a standard, specification, or regulation. The engineer in charge of the project was Paul J. Carlson, P.E. #85402.

The United States Government and the State of Texas do not endorse products or manufacturers. Trade or manufacturers' names appear herein solely because they are considered essential to the object of this report.

## **ACKNOWLEDGMENTS**

This project was conducted in cooperation with TxDOT and FHWA. The authors would like to thank the project director, Michael Chacon of the TxDOT Traffic Operations Division, for providing guidance and expertise on this project. Wade Odell of the TxDOT Research and Technology Implementation Office was the research engineer. The project advisors of the Project Monitoring Committee included:

- Rick Casteneda, TxDOT San Antonio District;
- John Gianotti, TxDOT San Antonio District;
- Carlos Ibarra, TxDOT Atlanta District;
- Sylvester Onwas, TxDOT Houston District;
- Ismael Soto, TxDOT Corpus Christi District; and
- Roy Wright, TxDOT Abilene District.

# TABLE OF CONTENTS

	Page
<b>LIST OF FIGURES</b> .....	<b>ix</b>
<b>LIST OF TABLES</b> .....	<b>xi</b>
<b>Chapter 1: OVERVIEW</b> .....	<b>1</b>
<b>Chapter 2: TEMPORARY SIGN SUPPORT WITH RIGID SIGN SUBSTRATE</b> .....	<b>3</b>
BACKGROUND .....	3
OBJECTIVE/SCOPE.....	4
CRASH TEST CONDITIONS .....	4
TEST ARTICLE .....	5
TEST NO. 463849-1 .....	9
Damage to Test Installation .....	12
Vehicle Damage.....	14
Occupant Risk Factors .....	14
Assessment of Test Results.....	18
TEST NO. 463849-2.....	20
Damage to Test Installation .....	21
Vehicle Damage.....	26
Occupant Risk Factors .....	26
Assessment of Test Results.....	26
CONCLUSIONS AND RECOMMENDATIONS .....	32
<b>Chapter 3: AASHTO SIGN SHEETING MATERIAL SPECIFICATION</b> .....	<b>35</b>
INTRODUCTION .....	35
SIGN SHEETING DEMONSTRATION .....	35
RECOMMENDED RETROREFLECTIVITY LEVELS .....	38
<b>Chapter 4: SIGN SHEETING STUDY: DESCRIPTION</b> .....	<b>41</b>
INTRODUCTION .....	41
SIGN DESIGN.....	42
TEST SUBJECTS.....	44
VEHICLE .....	44
DATA COLLECTION .....	48
RESULTS .....	49
<b>Chapter 5: CONTINUED EVALUATION OF LEAD-FREE THERMOPLASTIC PAVEMENT MARKINGS</b> .....	<b>51</b>
BACKGROUND .....	51
STUDY DESIGN.....	52
Measurements .....	54
RESULTS .....	55
Retroreflectivity .....	55
Color – 30 Meter.....	57

Color – 45/0 .....	59
FINDINGS .....	64
SUMMARY .....	66
<b>Chapter 6: ON-GOING RESEARCH ACTIVITIES .....</b>	<b>69</b>
SIGNS WITH LIGHT EMITTING DIODES.....	69
HURRICANE EVACUATION ROUTING .....	69
<b>REFERENCES.....</b>	<b>71</b>
<b>APPENDIX A: CRASH TEST AND DATA ANALYSIS PROCEDURES.....</b>	<b>73</b>
<b>APPENDIX B: TEST VEHICLE PROPERTIES AND INFORMATION .....</b>	<b>77</b>
<b>APPENDIX C: SEQUENTIAL PHOTOGRAPHS .....</b>	<b>83</b>
<b>APPENDIX D: VEHICLE ANGULAR DISPLACEMENTS AND ACCELERATIONS... </b>	<b>87</b>
<b>APPENDIX E: AASHTO’S SIGN SHEETING SPECIFICATION .....</b>	<b>101</b>
<b>APPENDIX F: LEAD-FREE PAVEMENT MARKING EVALUATION MEASUREMENTS AND PHOTOS.....</b>	<b>115</b>



## LIST OF FIGURES

	Page
Figure 1. Details of the Dual-Support Temporary Sign Support System. ....	7
Figure 2. Dual-Support Temporary Sign Support System before Test 463849-1. ....	8
Figure 3. Vehicle/Installation Geometrics for Test 463849-1. ....	10
Figure 4. Vehicle before Test 463849-1. ....	11
Figure 5. After Impact Trajectory Path for Test 463849-1. ....	12
Figure 6. Installation after Test 463849-1. ....	13
Figure 7. Vehicle after Test 463849-1. ....	15
Figure 8. Interior of Vehicle for Test 463849-1. ....	16
Figure 9. Summary of Results for <i>NCHRP Report 350</i> Test 3-71 (Head-On) on the Temporary Sign Supports. ....	17
Figure 10. Vehicle/Installation Geometrics for Test 463849-2. ....	22
Figure 11. Vehicle before Test 463849-2. ....	23
Figure 12. After Impact Trajectory Path for Test 463849-2. ....	24
Figure 13. Installation after Test 463849-2. ....	25
Figure 14. Vehicle after Test 463849-2. ....	27
Figure 15. Interior of Vehicle for Test 463849-2. ....	28
Figure 16. Summary of Results for <i>NCHRP Report 350</i> Test 3-71 (End-On) on the Temporary Sign Supports. ....	29
Figure 17. Riverside Campus. ....	41
Figure 18. Sign Layout. ....	42
Figure 19. Example of a Test Sign with a Landolt C. ....	43
Figure 20. Test Vehicle Headlight Illuminance. ....	45
Figure 21. Luminance Levels under Lowbeam Illumination (19.75 ft Offset). ....	47
Figure 22. Luminance Levels under Highbeam Illumination (19.75 ft Offset). ....	48
Figure 23. TxDOT Study Results. ....	49
Figure 24. SH 21 Lead-Free Thermoplastic Installation. ....	53
Figure 25. Yellow Thermoplastic Retroreflectivity Summary (Decks 1 and 2). ....	56
Figure 26. Yellow Thermoplastic Retroreflectivity Summary (Deck 3). ....	57
Figure 27. Avg 30 Meter Night Color of Leaded and Lead-Free Thermoplastic at US 79 Site. ...	58
Figure 28. Avg 30 Meter Night Color of Lead-Free Thermoplastic at SH 21 Site. ....	58
Figure 29. Avg 30 Meter Night Color of Lead-Free Thermoplastic at SH 21 Extruded Site. ....	59
Figure 30. Avg Daytime Color with 2 Degree Standard Observer at US 79 Site. ....	60
Figure 31. Avg Daytime Color with 10 Degree Standard Observer at US 79 Site. ....	61
Figure 32. Avg Nighttime Color with 2 Degree Standard Observer at US 79 Site. ....	61
Figure 33. Avg Daytime Color with 2 Degree Standard Observer at SH 21 Site. ....	62
Figure 34. Avg Daytime Color with 10 Degree Standard Observer at SH 21 Site. ....	62
Figure 35. Avg Nighttime Color with 2 Degree Standard Observer at SH 21 Site. ....	63
Figure 36. Avg Daytime Color with 2 Degree Standard Observer at SH 21 Extruded Site. ....	63
Figure 37. Diagram of I-10 Contraflow Transition. ....	70
Figure B1. Vehicle Properties for Test 463849-1. ....	77
Figure B2. Vehicle Properties for Test 463849-2. ....	80

Figure C1. Sequential Photographs for Test 463849-1 (Perpendicular and Oblique Views).....	83
Figure C2. Sequential Photographs for Test 463849-2 (Perpendicular and Oblique Views).....	85
Figure D1. Vehicle Angular Displacements for Test 463849-1. ....	87
Figure D2. Vehicle Longitudinal Accelerometer Trace for Test 463849-1 (Accelerometer Located at Center of Gravity). ....	88
Figure D3. Vehicle Lateral Accelerometer Trace for Test 463849-1 (Accelerometer Located at Center of Gravity). ....	89
Figure D4. Vehicle Vertical Accelerometer Trace for Test 463849-1 (Accelerometer Located at Center of Gravity). ....	90
Figure D5. Vehicle Longitudinal Accelerometer Trace for Test 463849-1 (Accelerometer Located over Rear Axle). ....	91
Figure D6. Vehicle Lateral Accelerometer Trace for Test 463849-1 (Accelerometer Located over Rear Axle). ....	92
Figure D7. Vehicle Vertical Accelerometer Trace for Test 463849-1 (Accelerometer Located over Rear Axle). ....	93
Figure D8. Vehicle Angular Displacements for Test 463849-2. ....	94
Figure D9. Vehicle Longitudinal Accelerometer Trace for Test 463849-2 (Accelerometer Located at Center of Gravity). ....	95
Figure D10. Vehicle Lateral Accelerometer Trace for Test 463849-2 (Accelerometer Located at Center of Gravity). ....	96
Figure D11. Vehicle Vertical Accelerometer Trace for Test 463849-2 (Accelerometer Located at Center of Gravity). ....	97
Figure D12. Vehicle Longitudinal Accelerometer Trace for Test 463849-2 (Accelerometer Located over Rear Axle). ....	98
Figure D13. Vehicle Lateral Accelerometer Trace for Test 463849-2 (Accelerometer Located over Rear Axle). ....	99
Figure D14. Vehicle Vertical Accelerometer Trace for Test 463849-2 (Accelerometer Located Over Rear Axle). ....	100
Figure F1. Photos of US 79 Leaded and Lead-Free Thermoplastic Markings over Time.....	120

## LIST OF TABLES

	<b>Page</b>
Table 1. Summary of Research Activities.....	1
Table 2. Performance Evaluation Summary for <i>NCHRP Report 350</i> Test 3-71 on the Temporary Sign Supports (Head-On).....	33
Table 3. Performance Evaluation Summary for <i>NCHRP Report 350</i> Test 3-71 on the Temporary Sign Supports (End-On).....	34
Table 4. Retroreflective Materials Used in Demonstration.....	36
Table 5. Coefficient of Retroreflection Values for AASHTO Ballot (cd/lx/m <sup>2</sup> ).....	38
Table 6. Mathematical Relations for AASHTO Types.....	39
Table 7. Sheeting Types Used.....	43
Table 8. Photometric Data at 200 and 120 ft.....	46
Table 9. Photometric Data at 400 and 240 ft.....	47
Table 10. NCHRP 5-18 Nighttime Chromaticity Coordinate Box Recommendations.....	52
Table 11. Lead-Free Yellow Thermoplastic Pavement Marking Measurements.....	54
Table B1. Exterior Crush Measurements for Test 463849-1.....	78
Table B2. Occupant Compartment Measurements for Test 463849-1.....	79
Table B3. Exterior Crush Measurements for Test 463849-2.....	81
Table B4. Occupant Compartment Measurements for Test 463849-2.....	82
Table F1. Color Specification for Yellow Pavement Markings.....	115
Table F2. Test Deck 1 US 79 Lead-Free Thermoplastic Data Summary.....	116
Table F3. Test Deck 1 US 79 Leaded Thermoplastic Data Summary.....	117
Table F4. Test Deck 2 SH 21 Lead-Free Thermoplastic Data Summary.....	118
Table F5. Test Deck 3 SH 21 Leaded Spray Thermoplastic Data Summary.....	119
Table F6. Test Deck 3 SH 21 Lead-Free Extruded Thermoplastic Double Drop Data Summary.....	119
Table F7. Test Deck 3 SH 21 Lead-Free Extruded Thermoplastic Single Drop Data Summary.....	119



## CHAPTER 1: OVERVIEW

This research project was established to be used as a mechanism for quick research results on high priority traffic control device topics that cannot be programmed in the traditional research program because of the need for a smaller scope and quicker turnaround time. This project is a continuation of TxDOT project 0-4701, which was active for five years (1–5).

Table 1 shows a summary of the activities conducted during project 0-6384 year one. Details of each activity are reported in the remaining chapters as noted in Table 1.

**Table 1. Summary of Research Activities.**

<b>Activity (Report Chapter)</b>	<b>Result</b>	<b>Status</b>
Developed temporary sign support with cross bracing (2)	Developed a sign support to meet NCHRP 350 requirements	The design has been implemented.
Provided technical support on AASHTO retroreflective sign sheeting material standard (3)	Hosted a sign demonstration for the AASHTO technical group and developed retroreflective classifications for the AASHTO sheeting specification	The specification will be concurrently balloted through AASHTO in late 2009 to early 2010.
Tested retroreflective sign sheeting materials (4)	Tested white on black signs to determine if they can create discomfort glare for motorists on rural low volume roads using high beams	A second phase will be conducted in the following year to investigate rotational issues on white on green signs.
Monitored lead-free thermoplastic pavement markings (5)	Nighttime color of yellow lead-free thermoplastic has fallen out of TxDOT color box and is approaching limits of the more forgiving FHWA color box	Will continue to monitor the existing lead-free thermoplastic pavement marking test decks.
Provided District support for hurricane evacuation routing (6)	Worked with the Houston District to provide assistance as needed.	Will continue this effort in the following year, focused on the Corpus Christi District.
Researched signs supplemented with LEDs (6)	Identified the way LEDs are being used to supplement traffic signs	Held a demonstration of LED signs in March 2010 at the TAMU Riverside Campus.



## **CHAPTER 2: TEMPORARY SIGN SUPPORT WITH RIGID SIGN SUBSTRATE**

### **BACKGROUND**

Proper traffic control and delineation are critical to the safety of work zones. Work zone traffic control devices such as temporary sign supports are the primary means of communicating information to motorists in these areas. However, these devices may themselves pose a safety hazard to motorists or work zone personnel when impacted by errant vehicles. Thus, the Federal Highway Administration (FHWA) and the Manual on Uniform Traffic Control Devices (MUTCD) (6) require that work zone traffic control devices be crashworthy.

National Cooperative Highway Research Program (NCHRP) *Report 350* (7) contains recommended procedures for testing and evaluation of work zone traffic control devices. In recent years, State Departments of Transportation (DOTs) and private manufacturers have devoted considerable resources to design temporary sign supports for use in work zones that comply with *NCHRP Report 350*. As an example, a sign support system fabricated with 4-inch × 4-inch wooden uprights was successfully crash tested with a 4-ft × 4-ft plywood sign panel (8, 9). However, while such systems are crashworthy, their weight makes them difficult to handle and transport.

Consequently, some user agencies and contractors expressed a desire for a more lightweight sign support system. Allied Tube & Conduit and United Rentals collaborated on the design of a temporary sign support system fabricated from perforated steel tubing that possesses some of the functional characteristics desired by contractors, state DOTs, and other user agencies (10). The system weighs considerably less than systems fabricated from dimensional lumber, thereby making it easier to handle and transport. Further, the steel tubing simplifies assembly and has greater field adjustability to accommodate varying site conditions. The galvanized steel provides good durability and resistance to environmental attack without the need for painting, which is a maintenance requirement for wooden systems.

However, this system is restricted to use with a corrugated plastic sign panel. While the corrugated plastic sign substrate was lightweight, it did not have the durability desired by some contractors and district maintenance personnel. They expressed a need for a lightweight,

crashworthy temporary sign support system compatible with stiffer, more durable sign substrates such as plywood and aluminum.

## **OBJECTIVE/SCOPE**

The objective of this task was to develop, test, and evaluate a temporary sign support system in accordance with the recommendations of *NCHRP Report 350*. It was stipulated that the sign support system be compatible with “rigid” sign substrates such as plywood and aluminum. It was further desired that the sign support frame be relatively lightweight, durable, and possess a reasonable degree of adjustability to accommodate placement under varying site conditions.

Texas Transportation Institute (TTI) researchers decided to utilize perforated steel tubing for the frame of the new temporary sign support system. Use of perforated steel tubing makes the frame lightweight (compared to wooden construction), durable, easy to assemble, and adjustable. The key task thus became sizing the members and developing framing details that provide the strength and stiffness needed to meet the impact performance requirements.

Previous crash tests were critically analyzed to understand the impact response and failure modes of perforated steel tubing. Five different design concepts were developed and reviewed with the project monitoring committee. The system selected by TxDOT for further evaluation incorporated diagonal bracing across the two vertical uprights. The diagonal braces are intended to stiffen the impact region and prevent or delay collapse of the uprights when struck by the bumper of an impacting vehicle. This changes the trajectory of the sign support system and potentially reduces the severity of any secondary contact that occurs between the sign support system and the impacting vehicle. Another perceived benefit of the diagonal bracing is that it will allow inspectors to readily differentiate the new system from the existing perforated steel tube sign system that is limited to use with corrugated plastic sign substrates. This chapter presents details of the temporary sign support, a description of the crash testing, an assessment of the test results, and implementation recommendations.

## **CRASH TEST CONDITIONS**

All crash test, data analysis, and evaluation and reporting procedures followed under this project were in accordance with guidelines presented in *NCHRP Report 350*. Appendix A



presents brief descriptions of these procedures. The recommended test matrix for temporary signs supports consists of the following two crash tests.

*NCHRP Report 350 Test Designation 3-70*: An 1808-lb passenger car impacting the temporary support at an impact speed of 22 mi/h and impact angle of 0–20 degrees. This test evaluates the breakaway, fracture, or yielding mechanism of the support and occupant risk factors.

*NCHRP Report 350 Test Designation 3-71*: An 1808-lb passenger car impacting the temporary support at an impact speed of 62 mi/h and impact angle of 0–20 degrees. This test evaluates the test vehicle stability and test article trajectory, as well as occupant risk factors.

The testing reported herein was performed following the impact conditions of test designation 3-71 of *NCHRP Report 350*. This test is considered to be the critical test for work zone sign supports due to the increased propensity for occupant compartment intrusion at higher speeds.

FHWA requires the impact performance of temporary work zone sign supports be evaluated for two different orientations. In addition to the common scenario involving the car impacting the device head-on (i.e., 0 deg.), an impact with the device turned 90 degrees is also required. This test condition accounts for the common field practice of rotating a device out of view of traffic until it is needed again and/or picked up and moved by work zone personnel.

In order to reduce testing cost, FHWA permits the evaluation of both the 0 and 90 degree orientations using two separate devices impacted in sequence in a single crash test. This approach was used to evaluate the perforated steel tube sign support system tested under this project. Two separate sign support systems were placed on a concrete apron in the path of the vehicle approximately 30 ft apart from one another. The first system was oriented at 0 degrees (i.e., perpendicular to the path of the vehicle) and the second at 90 degrees (i.e., parallel to the path of the vehicle). In the event that the first system interferes with the evaluation of the second system, another crash test needs to be performed in order to complete the impact performance evaluation.

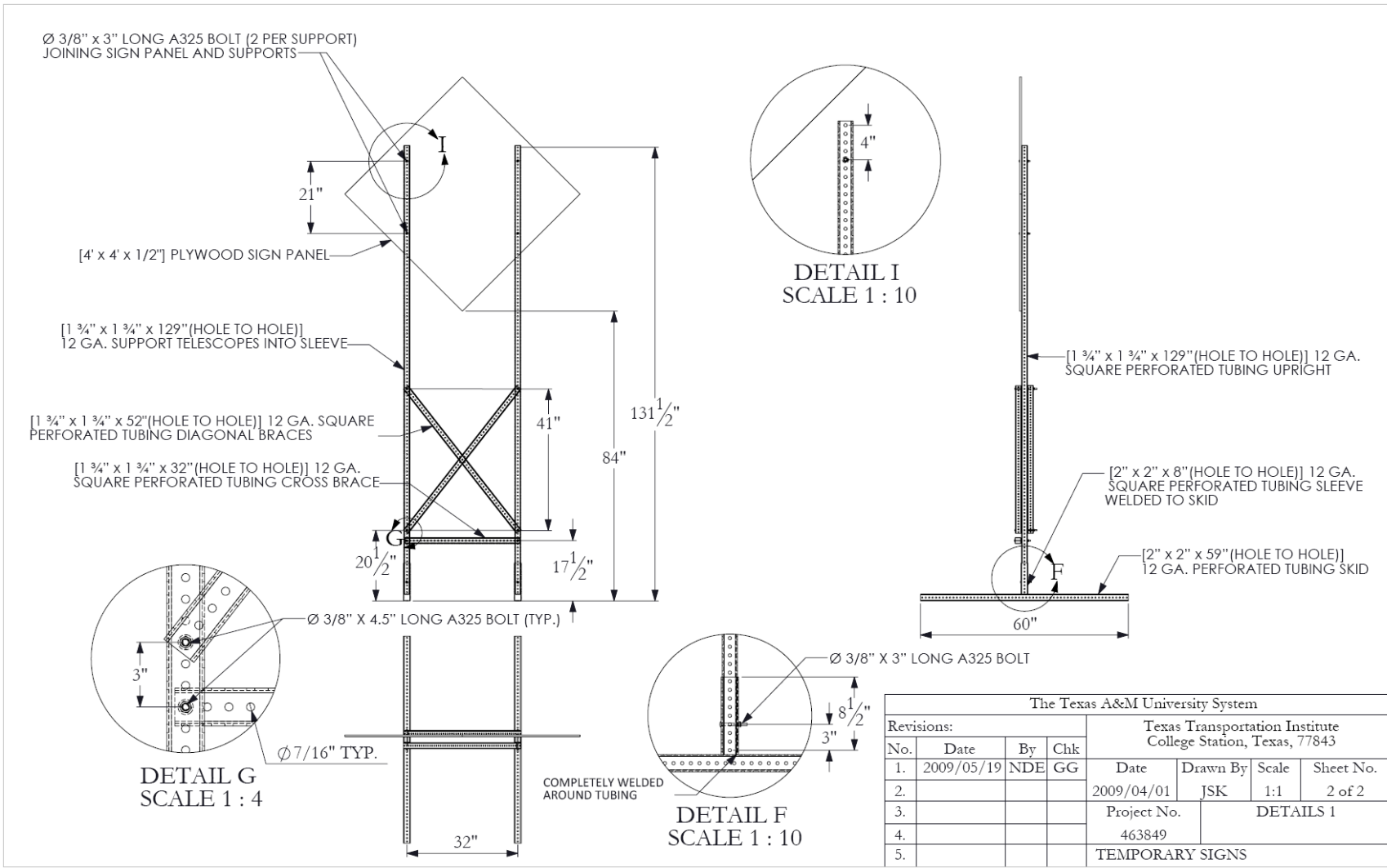
## **TEST ARTICLE**

Figure 1 provides details of the dual-support temporary sign support system tested in the study. A 9-inch long vertical sleeve fabricated from 2-inch square, 12-gauge perforated steel

tubing was welded to the center of each of two 5-ft long skids fabricated from the same material. A 1 $\frac{3}{4}$ -inch square  $\times$  10.75 ft long, 12-gauge perforated steel upright was inserted into the vertical sleeve and secured using a  $\frac{3}{8}$ -inch diameter  $\times$  3-inch long A325 bolt. A 1 $\frac{3}{4}$ -inch square  $\times$  32-inch long, 12-gauge horizontal cross brace was bolted to the uprights at a height of 17 $\frac{1}{2}$  inches above ground using two  $\frac{3}{8}$ -inch diameter  $\times$  4 $\frac{1}{2}$ -inch long A325 through bolts. The two vertical supports were spaced 32 inches apart center to center. Two 1 $\frac{3}{4}$ -inch square  $\times$  52-inch long, 12-gauge braces are bolted diagonally across the vertical uprights just above the horizontal cross brace using a  $\frac{3}{8}$ -inch diameter  $\times$  4 $\frac{1}{2}$ -inch long A325 through bolt at each end.

A 4 ft  $\times$  4 ft  $\times$   $\frac{1}{2}$  inch thick plywood sign panel was attached to the vertical supports in a diamond configuration using four  $\frac{3}{8}$ -inch diameter  $\times$  3-inch long A325 bolts—two through each support. The bottom edge of the sign panel was mounted 7 ft above ground. A 40-lb sandbag was placed on the front and back of each skid for a total of four sand bags. The unballasted weight of the sign support system was 130 lb. Figure 2 provides photographs of the completed test installation.

7



The Texas A&M University System							
Revisions:				Texas Transportation Institute College Station, Texas, 77843			
No.	Date	By	Chk	Date	Drawn By	Scale	Sheet No.
1.	2009/05/19	NDE	GG	2009/04/01	JSK	1:1	2 of 2
3.				Project No.	DETAILS 1		
4.				463849			
5.				TEMPORARY SIGNS			

T:\2008-2009\463849-TxDOT-TempSign\Cross-Bar Design\Drawing\_Cross\_Bar\_Ac\_Built

**Figure 1. Details of the Dual-Support Temporary Sign Support System.**



**Figure 2. Dual-Support Temporary Sign Support System before Test 463849-1.**

## **TEST NO. 463849-1**

A 2001 Suzuki Swift, shown in Figure 3 and Figure 4, was used for the crash test. Test inertia weight of the vehicle was 1861 lb, and its gross static weight was 2026 lb. The height to the lower edge of the vehicle front bumper was 15.75 inches, and the height to the upper edge of the front bumper it was 20.28 inches. Figure B1 in Appendix B gives additional dimensions and information on the vehicle. The vehicle was directed into the installation using the cable reverse tow and guidance system and was released to be free-wheeling and unrestrained just prior to impact.

The 2001 Suzuki Swift, traveling at an impact speed of 60.6 mi/h, impacted both legs of the first temporary sign support head-on at an impact angle of 0 degrees. Shortly after impact, the support yielded to the vehicle and began to ride along the front of the vehicle, and at 0.079 s, the sign support hooked the hood, which crumpled upward. At 0.151 s, the sign panel contacted the roof of the vehicle and remained situated there until 0.354 s, when the skirts of the first temporary sign support contacted the uprights of the second temporary sign support.

At 0.363 s, the vehicle impacted the second temporary sign support at a speed of 53.1 mi/h at an impact angle of 90 degrees. The second temporary sign support engaged the first support, pushing the first support into the windshield and then off the vehicle. As the vehicle exited the view of the high-speed cameras, the supports were still in contact with the vehicle. Figure C1 in Appendix C shows sequential photographs of the test period. Brakes on the vehicle were applied at 1.7 s after impact, and the vehicle came to rest 221 ft downstream of impact and 3.5 ft to the right of centerline of the installation.



**Figure 3. Vehicle/Installation Geometrics for Test 463849-1.**



**Figure 4. Vehicle before Test 463849-1.**

## Damage to Test Installation

Figure 5 and Figure 6 show the damage to the temporary sign supports. The first temporary sign support stayed together as a unit but was deformed. The support came to rest 227 ft downstream of the impact point and 12 ft to left of centerline of the installation. One of the legs of the second temporary sign support separated from the unit and rested 212 ft downstream of impact and 10 ft to the left of centerline, while the remainder of the unit rested 176 ft downstream of impact and 18 ft to the left of centerline of the installation.



**Figure 5. After Impact Trajectory Path for Test 463849-1.**





**Figure 6. Installation after Test 463849-1.**

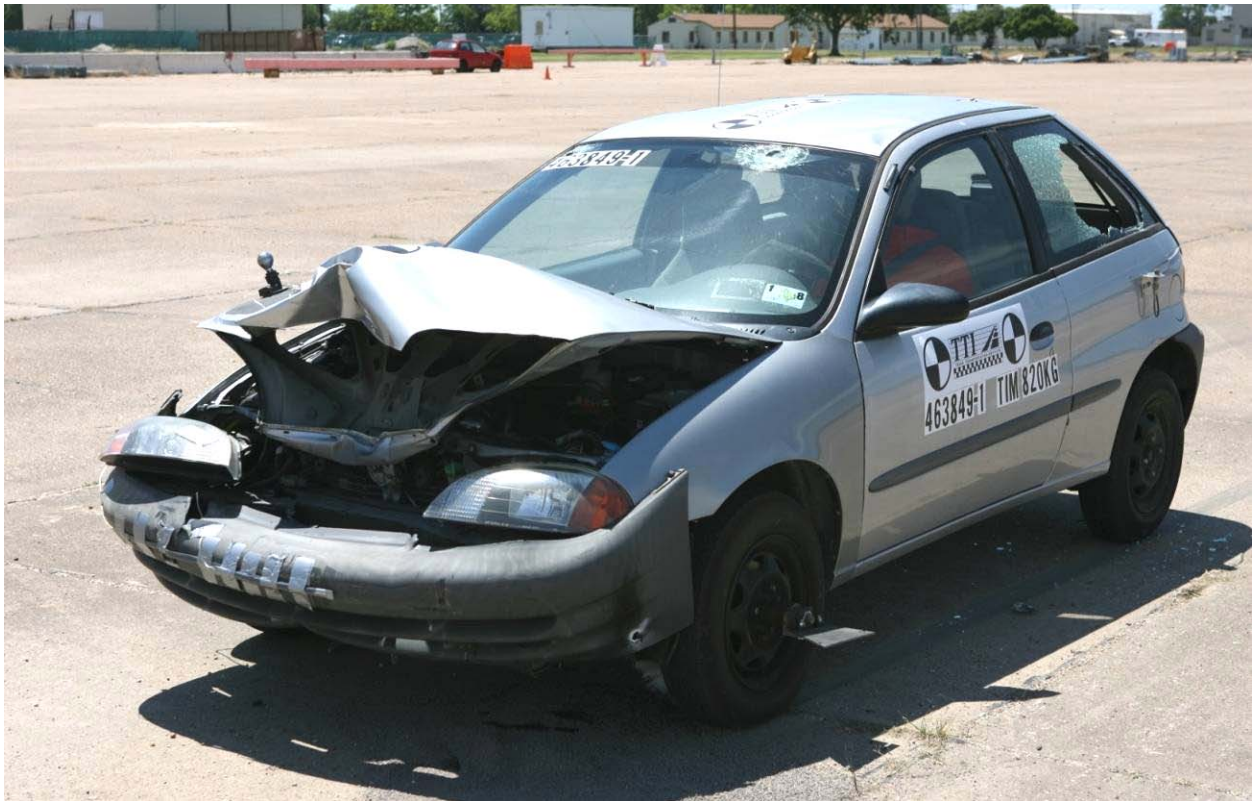
## **Vehicle Damage**

Figure 7 shows the damage to the front of the vehicle, the windshield, and the roof of the vehicle. The hood was crumpled upward. Two pinprick holes were found in the windshield, one in the upper corner on the passenger side where the glass was cracked over an area measuring 6.3 inches  $\times$  5.5 inches  $\times$  0.8 inches deep, and the second in a damaged area that measured 8.3 inches  $\times$  5.7 inches  $\times$  1.2 inches deep. It is noted that the windshield damage resulted from the first sign support system being shoved into the windshield by contact with the second sign support system and was not attributable to the vehicle impacting the first sign support system. The roof had several dents, the deepest of which was 0.5-inch deep. The left rear window glass was also broken. Maximum exterior crush to the vehicle was 7.9 inches in the center front at bumper height. No occupant compartment deformation occurred. Figure 8 shows photographs of the interior of the vehicle. Exterior crush measurements and occupant compartment measurements can be found in Appendix B, Tables B1 and B2.

## **Occupant Risk Factors**

Figure 9 presents pertinent information from the test. Data from the accelerometer, located at the vehicle center of gravity, were digitized for evaluation of occupant risk. During the contact with the first temporary sign support, no occupant contact occurred. Figures D1 through D7 in Appendix D present vehicle angular displacements and accelerations versus time traces.

The impact performance with the second sign support oriented at 90 degrees could not be evaluated due to interference from the first sign support system. Therefore, it was concluded that a second full-scale crash test was needed to complete the performance assessment of the perforated square steel tube support with rigid sign substrate.



**Figure 7. Vehicle after Test 463849-1.**

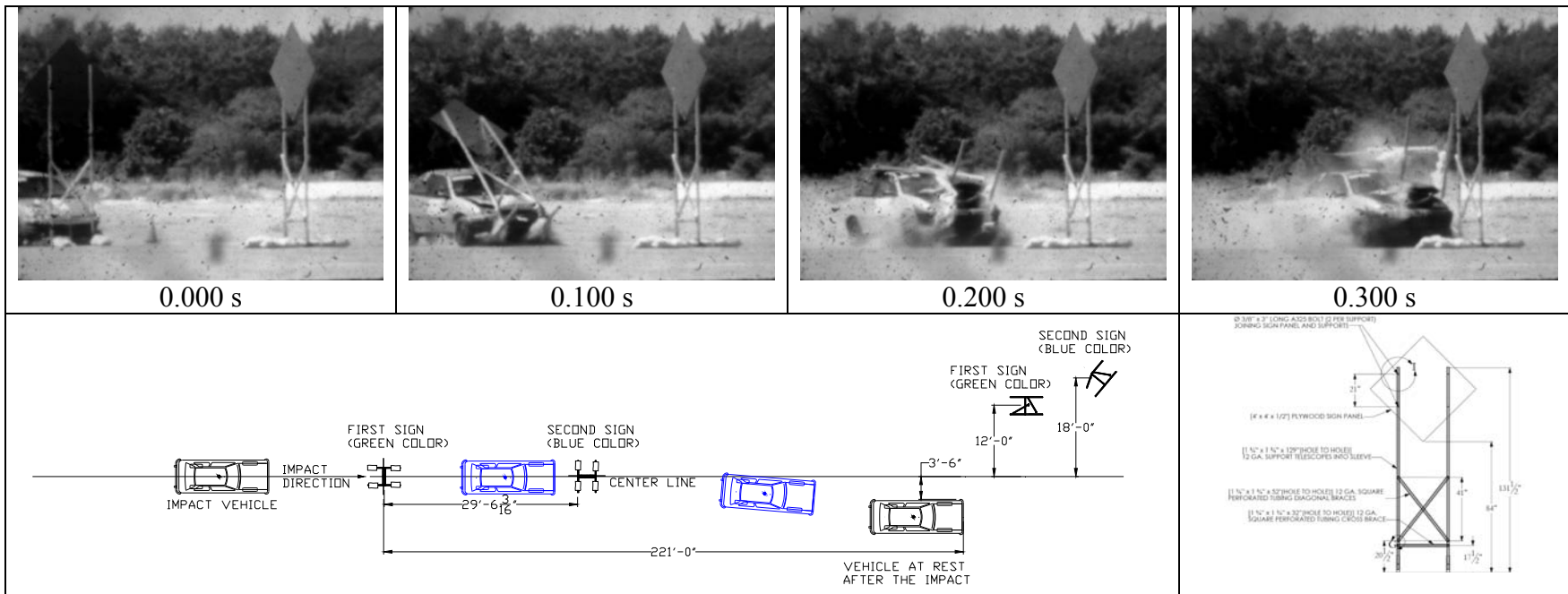


Before Test

After Test



**Figure 8. Interior of Vehicle for Test 463849-1.**



**General Information**

Test Agency..... Texas Transportation Institute  
 Test No. .... 463849-1 (Head-on)  
 Date ..... 2009-05-28

**Test Article**

Type..... Temporary Sign Support  
 Name ..... Dual-Support Temporary Sign Support  
 Installation Height..... 7.0 ft  
 Material or Key Elements ..... 12-gauge perforated steel tubing with 4 ft x 4 ft x 1/2 inch thick plywood sign panel

**Soil Type and Condition**

Concrete Pavement, Dry

**Test Vehicle**

Designation..... 820C  
 Model..... 2001 Suzuki Swift  
 Mass  
 Curb..... 1828 lb  
 Test Inertial..... 1861 lb  
 Dummy ..... 165 lb  
 Gross Static..... 2026 lb

**Impact Conditions**

Speed .....60.6 mi/h  
 Angle.....0 degree

**Exit Conditions**

Speed .....Rode with  
 Angle.....vehicle

**Occupant Risk Values**

Impact Velocity  
 Longitudinal .....No Contact  
 Lateral .....No Contact  
 THIV .....5.4 mi/h  
 Ridedown Accelerations  
 Longitudinal .....N/A  
 Lateral .....N/A  
 PHD .....9.6 G  
 ASI .....0.45  
 Max. 0.050-s Average  
 Longitudinal .....-4.6 G  
 Lateral .....-0.8 G  
 Vertical .....-2.6 G

**Debris Scatter**

Longitudinal ..... 227 ft  
 Lateral ..... 12 ft left

**Vehicle Damage**

Exterior  
 VDS..... 12FD2  
 CDC ..... 12FDEW2  
 Maximum Exterior  
 Vehicle Crush..... 3.5 inches  
 Interior  
 OCDI ..... FS0000000  
 Maximum Occupant Compartment  
 Deformation ..... 0 inch

**Post-Impact Behavior**

(during 1.0 sec after impact)  
 Max. Yaw Angle ..... 4 degrees  
 Max. Pitch Angle ..... 4 degrees  
 Max. Roll Angle ..... -3 degrees

**Figure 9. Summary of Results for NCHRP Report 350 Test 3-71 (Head-On) on the Temporary Sign Supports.**

## Assessment of Test Results

An assessment of the head-on (zero degree) impact with the first temporary sign support system based on the applicable *NCHRP Report 350* safety evaluation criteria is provided below.

### Structural Adequacy

*B. The test article should readily activate in a predictable manner by breaking away, fracturing, or yielding.*

Result: The first temporary sign support readily activated as designed by yielding to the vehicle. (PASS)

### Occupant Risk

*D. Detached elements, fragments, or other debris from the test article should not penetrate or show potential for penetrating the occupant compartment, or present an undue hazard to other traffic, pedestrians, or personnel in a work zone. Deformation of, or intrusions into, the occupant compartment that could cause serious injuries should not be permitted.*

Result: The first temporary sign support yielded to the vehicle. The detached elements did not penetrate or show potential to penetrate the occupant compartment. The support rode along with the vehicle and did not present undue hazard to others in the area. The windshield damage was not associated with the initial impact with the first support, but occurred after the second sign support accelerated the first sign support system into the windshield. (PASS)

*E. Detached element, fragments or other debris from the test article, or vehicular damage should not block the driver's vision or otherwise cause the driver to lose control of the vehicle.*

Result: No detached elements obstructed the driver's view. (PASS)

*F. The vehicle should remain upright during and after collision although moderate roll, pitching, and yawing are acceptable.*

Result: The 820C vehicle remained upright during and after the collision event. (PASS)

*H. Occupant impact velocities should satisfy the following:*

*Longitudinal Occupant Impact Velocity*

Preferred  
9.8 ft/s

Maximum  
16.4 ft/s

Result: No occupant impact occurred during the initial contact with the first sign support. (PASS)

- I. *Occupant ridedown accelerations should satisfy the following:*
- |   |                |
|---|----------------|
| <u>Longitudinal and Lateral Occupant Ridedown Accelerations – G</u> |                |
| <u>Preferred</u>  | <u>Maximum</u> |
| 15  | 20             |

Result: No occupant impact occurred. (PASS)

**Vehicle Trajectory**

- K. *After collision, it is preferable that the vehicle’s trajectory not intrude into adjacent traffic lanes.*

Result: The 820C vehicle did not intrude into adjacent traffic lanes. (PASS)

- N. *Vehicle trajectory behind the test article is acceptable.*

Result: The 820C vehicle came to rest behind the test articles. (PASS)

The following supplemental evaluation factors and terminology, as presented in the FHWA memo entitled “ACTION: Identifying Acceptable Highway Safety Features,” were used for visual assessment of test results (11). Factors underlined below pertain to the results of the crash test reported herein.

***Passenger Compartment Intrusion***

- |  |   |
|--|---|
| <p>1. <i>Windshield Intrusion</i></p> <ul style="list-style-type: none"> <li>a. <i>No windshield contact</i></li> <li>b. <i>Windshield contact, no damage</i></li> <li>c. <u><i>Windshield contact, no intrusion<sup>1</sup></i></u></li> <li>d. <i>Device embedded in windshield, no significant intrusion</i></li> </ul> <p>2. <i>Body Panel Intrusion</i></p> | <ul style="list-style-type: none"> <li>e. <i>Complete intrusion into passenger compartment</i></li> <li>f. <i>Partial intrusion into passenger compartment</i></li> </ul> <p style="text-align: center;">yes          or          <u>no</u></p> |
|--|---|

***Loss of Vehicle Control***

- |   |   |
|---|---|
| <ul style="list-style-type: none"> <li>1. <i>Physical loss of control</i></li> <li>2. <i>Loss of windshield visibility</i></li> </ul> | <ul style="list-style-type: none"> <li>3. <i>Perceived threat to other vehicles</i></li> <li>4. <u><i>Debris on pavement</i></u></li> </ul> |
|---|---|

***Physical Threat to Workers or Other Vehicles***

- 1. *Harmful debris that could injure workers or others in the area*
  - 2. *Harmful debris that could injure occupants in other vehicles*
- Debris remained with the vehicle.

---

<sup>1</sup> Windshield damage not associated with impact with first sign support.

### ***Vehicle and Device Condition***

#### ***1. Vehicle Damage***

- a. None*
- b. Minor scrapes, scratches or dents*
- c. Significant cosmetic dents*
- d. Major dents to grill and body panels*
- e. Major structural damage*

#### ***2. Windshield Damage***

- a. None*
- b. Minor chip or crack*
- c. Broken, no interference with visibility<sup>1</sup>*
- d. Broken or shattered, visibility restricted but remained intact*
- e. Shattered, remained intact but partially dislodged*
- f. Large portion removed*
- g. Completely removed*

#### ***3. Device Damage***

- a. None*
- b. Superficial*
- c. Substantial, but can be straightened*
- d. Substantial, replacement parts needed for repair*
- e. Cannot be repaired*

### **TEST NO. 463849-2**

As noted, the impact performance with the second sign support oriented at 90 degrees could not be evaluated due to interference from the first sign support system. Therefore, a second full-scale crash test was performed to complete the performance assessment of the perforated square steel tube support with rigid sign substrate.

A 1996 Geo Metro, shown in Figure 10 and Figure 11, was used for the second crash test. The test inertia weight of the vehicle was 1861 lb, and its gross static weight was 2028 lb. The height to the lower edge of the vehicle front bumper was 15.75 inches, and the height to the upper edge of the front bumper was 20.28 inches. Figure B2 in Appendix B gives additional dimensions and information on the vehicle. The vehicle was directed into the installation using the cable reverse tow and guidance system and was released to be free-wheeling and unrestrained just prior to impact.

The 1996 Geo Metro, traveling at an impact speed of 62.0 mi/h, impacted both legs of the temporary sign support end-on at an impact angle of 90 degrees. Shortly after impact, the left support began to deform, and at 0.007 s after impact, the right support began to move away from the vehicle. The right support fractured at the connection to the cross brace at 0.022 s. As the vehicle continued to travel forward, the entire sign support installation rotated as a unit in front of the vehicle. At 0.115 s, the vehicle lost contact with the support while traveling at a speed of 57.3 mi/h. The rotating support structure contacted the roof at 0.197 s. At 0.275 s, the sign



panel lost contact with the vehicle and traveled along with the vehicle. Brakes on the vehicle were applied at 1.6 s after impact, and the vehicle came to rest 272 ft downstream of impact. Figure C2 in Appendix C show sequential photographs of the test period.

### **Damage to Test Installation**

Figure 12 and Figure 13 show the damage to the temporary sign support. The sign panel from the temporary sign support came to rest 148 ft downstream of the impact point and 15 ft to left of centerline of the installation. One of the legs and a skid of the temporary sign support separated from the unit and rested 399 ft downstream of impact and 13 ft to the right of centerline, while the remainder of the unit rested 173 ft downstream of impact and 4 ft to the right of centerline of the installation. The vehicle came to rest 272 ft downstream of the installation.



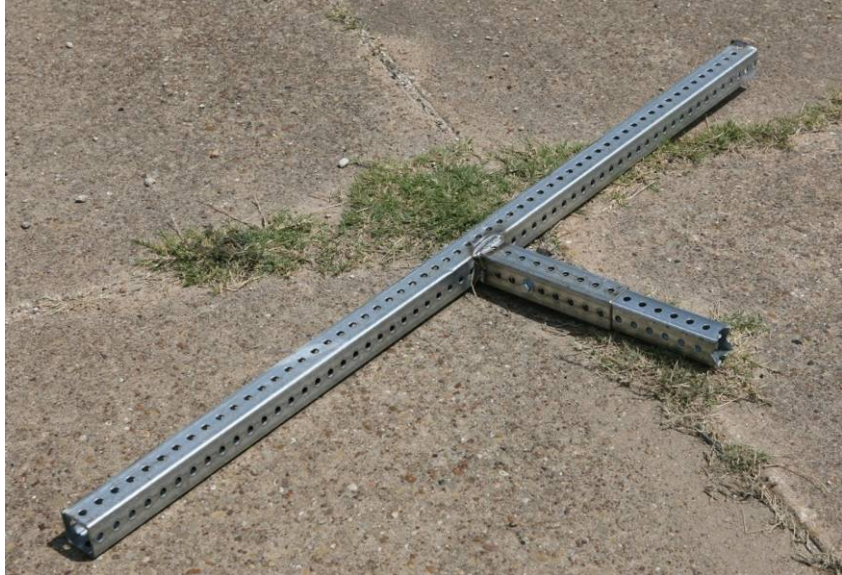
**Figure 10. Vehicle/Installation Geometrics for Test 463849-2.**



**Figure 11. Vehicle before Test 463849-2.**



**Figure 12. After Impact Trajectory Path for Test 463849-2.**



**Figure 13. Installation after Test 463849-2.**

## Vehicle Damage

Figure 14 shows the damage to the front of the vehicle, the hood and the roof of the vehicle. The hood was crumpled upward. Maximum exterior crush to the vehicle was 9.1 inches in the center front at bumper height. No occupant compartment deformation occurred. Figure 15 shows photographs of the interior of the vehicle. Exterior crush measurements and occupant compartment measurements can be found in Appendix B, Tables B3 and B4.

## Occupant Risk Factors

Data from the accelerometer, located at the vehicle center of gravity, were digitized for evaluation of occupant risk. The occupant impact velocity in the longitudinal direction was 7.9 ft/s at 0.283 s, the highest 0.010-s occupant ridedown acceleration was -1.3 G from 1.733 to 1.743 s, and the maximum 0.050-s average acceleration was -4.9 G between 0.004 and 0.054 s. In the lateral direction, the occupant impact velocity was 4.6 ft/s at 0.283 s, the highest 0.010-s occupant ridedown acceleration was -0.3 G from 0.321 to 0.331 s, and the maximum 0.050-s average was -1.2 G between 0.054 and 0.104 s.

Figure 16 presents these data and other pertinent information from the test. Figures D8 through D14 in Appendix D present vehicle angular displacements and accelerations versus time traces.

## Assessment of Test Results

An assessment of the test based on the applicable *NCHRP Report 350* safety evaluation criteria is provided below.

### **Structural Adequacy**

*B. The test article should readily activate in a predictable manner by breaking away, fracturing, or yielding.*

**Result:** The temporary sign support readily activated as designed by yielding to the vehicle. (PASS)



**Figure 14. Vehicle after Test 463849-2.**



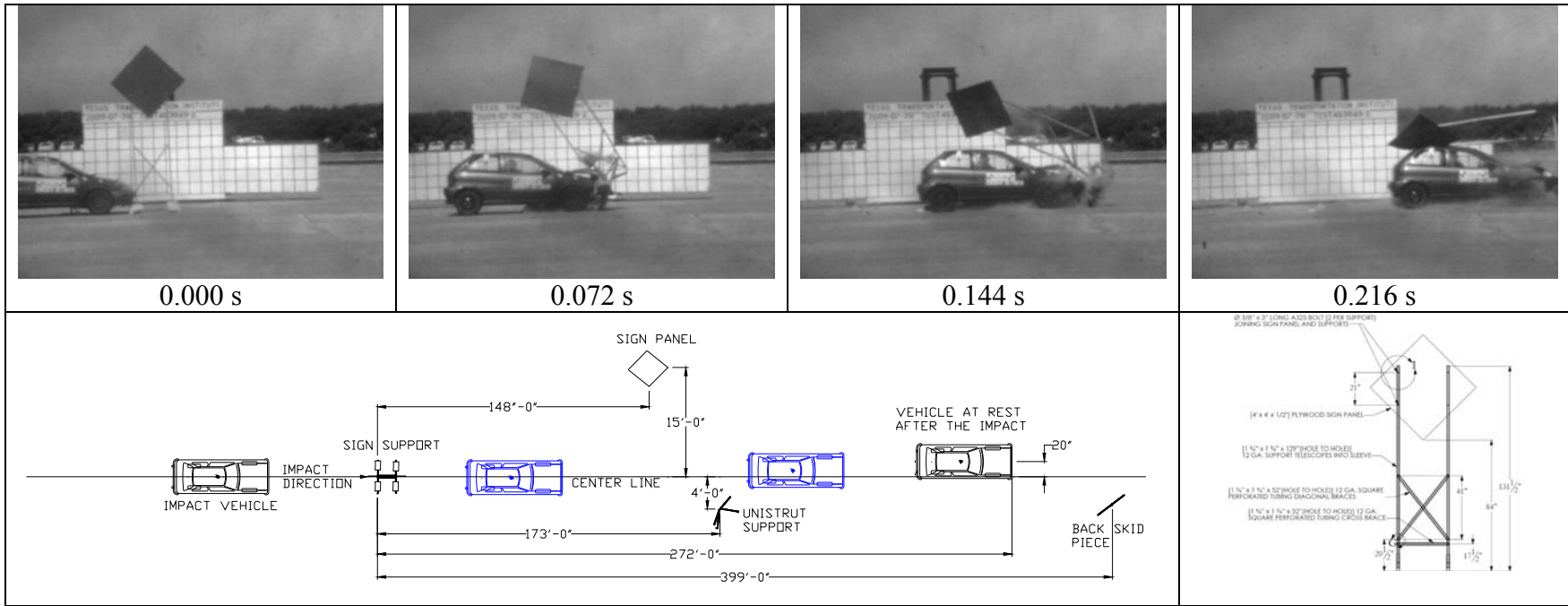
Before Test

After Test



**Figure 15. Interior of Vehicle for Test 463849-2.**





**General Information**

Test Agency..... Texas Transportation Institute  
 Test No. .... 463849-2 (End-on)  
 Date ..... 2009-07-28

**Test Article**

Type..... Temporary Sign Support  
 Name ..... Dual-Support Temporary Sign Support  
 Installation Height..... 7.0 ft  
 Material or Key Elements ..... 12-gauge perforated steel tubing 4 ft x 4 ft x 1/2 inch thick plywood sign panel  
 Soil Type and Condition..... Concrete Pavement, Dry

**Test Vehicle**

Designation..... 820C  
 Model..... 1996 Geo Metro  
 Mass  
 Curb..... 1852 lb  
 Test Inertial..... 1861 lb  
 Dummy ..... 167 lb  
 Gross Static..... 2028 lb

**Impact Conditions**

Speed .....62.0 mi/h  
 Angle.....0 degree

**Exit Conditions**

Speed .....Rode with  
 Angle.....vehicle

**Occupant Risk Values**

Impact Velocity  
 Longitudinal .....7.9 ft/s  
 Lateral .....4.6 ft/s  
 THIV.....6.3 ft/s  
 Ridedown Accelerations  
 Longitudinal .....-1.3 G  
 Lateral .....-0.3 G  
 PHD ..... 1.3 G  
 ASI .....0.44  
 Max. 0.050-s Average  
 Longitudinal .....-4.9 G  
 Lateral .....-1.2 G  
 Vertical .....-1.6 G

**Debris Scatter**

Longitudinal..... 399 ft  
 Lateral ..... 15 ft

**Vehicle Damage**

Exterior  
 VDS..... 12FC2  
 CDC ..... 12FCEN2  
 Maximum Exterior  
 Vehicle Crush..... 9.1 inches  
 Interior  
 OCDI ..... FS000000  
 Maximum Occupant Compartment  
 Deformation ..... 0 inch

**Post-Impact Behavior**

(during 1.0 sec after impact)  
 Max. Yaw Angle ..... 1 degrees  
 Max. Pitch Angle ..... 2 degrees  
 Max. Roll Angle ..... 1 degrees

**Figure 16. Summary of Results for NCHRP Report 350 Test 3-71 (End-On) on the Temporary Sign Supports.**

**Occupant Risk**

D. *Detached elements, fragments, or other debris from the test article should not penetrate or show potential for penetrating the occupant compartment, or present an undue hazard to other traffic, pedestrians, or personnel in a work zone. Deformation of, or intrusions into, the occupant compartment that could cause serious injuries should not be permitted.*

Result: The temporary sign support yielded to the vehicle. The detached elements did not penetrate or show potential to penetrate the occupant compartment. The support rode along with the vehicle and did not present undue hazard to others in the area. No deformation of the occupant compartment occurred. (PASS)

E. *Detached element, fragments or other debris from the test article, or vehicular damage should not block the driver’s vision or otherwise cause the driver to lose control of the vehicle.*

Result: No detached elements obstructed the driver’s view. (PASS)

F. *The vehicle should remain upright during and after collision although moderate roll, pitching, and yawing are acceptable.*

Result: The 820C vehicle remained upright during and after the collision event. (PASS)

I. *Occupant impact velocities should satisfy the following:*

*Longitudinal Occupant Impact Velocity*

<u>Preferred</u>	<u>Maximum</u>
9.8 ft/s	16.4 ft/s

Result: Longitudinal impact velocity was 7.9 ft/s. (PASS)

I. *Occupant ridedown accelerations should satisfy the following:*

Longitudinal and Lateral Occupant Ridedown Accelerations – G

<u>Preferred</u>	<u>Maximum</u>
16	20

Result: Longitudinal occupant ridedown acceleration was -1.3 G, and lateral occupant ridedown acceleration was -0.3 G. (PASS)

**Vehicle Trajectory**

K. *After collision, it is preferable that the vehicle’s trajectory not intrude into adjacent traffic lanes.*

Result: The 820C vehicle did not intrude into adjacent traffic lanes. (PASS)

N. *Vehicle trajectory behind the test article is acceptable.*

Result: The 820C vehicle came to rest behind the original positions of the test articles. (PASS)

The following supplemental evaluation factors and terminology, as presented in the FHWA memo entitled “ACTION: Identifying Acceptable Highway Safety Features,” were used for visual assessment of test results (11). Factors underlined below pertain to the results of the crash test reported herein.

***Passenger Compartment Intrusion***

- |   |   |
|---|---|
| 1. <i>Windshield Intrusion</i>                                    |   |
| a. <u>No windshield contact</u>                                   | e. <i>Complete intrusion into passenger compartment</i> |
| b. <i>Windshield contact, no damage</i>                           | f. <i>Partial intrusion into passenger compartment</i>  |
| c. <i>Windshield contact, no intrusion</i>                        |   |
| d. <i>Device embedded in windshield, no significant intrusion</i> |   |
| 2. <i>Body Panel Intrusion</i>                                    | yes          or <u>no</u>                               |

***Loss of Vehicle Control***

- |   |  |
|---|--|
| 1. <i>Physical loss of control</i>      | 3. <i>Perceived threat to other vehicles</i> |
| 2. <i>Loss of windshield visibility</i> | 4. <u><i>Debris on pavement</i></u>          |

***Physical Threat to Workers or Other Vehicles***

1. *Harmful debris that could injure workers or others in the area*
  2. *Harmful debris that could injure occupants in other vehicles*
- Debris remained with the vehicle.

***Vehicle and Device Condition***

- |  |   |
|--|---|
| 1. <i>Vehicle Damage</i>   |   |
| a. <i>None</i>   | <u>d. <i>Major dents to grill and body panels</i></u>             |
| b. <i>Minor scrapes, scratches or dents</i>                              | e. <i>Major structural damage</i>                                 |
| c. <i>Significant cosmetic dents</i>                                     |   |
| 2. <i>Windshield Damage</i>  |   |
| a. <u><i>None</i></u>  | e. <i>Shattered, remained intact but partially dislodged</i>      |
| b. <i>Minor chip or crack</i>  | f. <i>Large portion removed</i>                                   |
| c. <i>Broken, no interference with visibility</i>                        | g. <i>Completely removed</i>                                      |
| d. <i>Broken or shattered, visibility restricted but remained intact</i> |   |
| 3. <i>Device Damage</i>  |   |
| a. <i>None</i>   | <u>d. <i>Substantial, replacement parts needed for repair</i></u> |
| b. <i>Superficial</i>  | e. <i>Cannot be repaired</i>                                      |
| c. <i>Substantial, but can be straightened</i>                           |   |

## CONCLUSIONS AND RECOMMENDATIONS

As summarized in Table 2, the perforated square steel tube support with rigid sign substrate performed acceptably in a head-on (zero degree) impact. Interference of first sign support with second sign support prevented evaluation of the impact performance for the 90 degree orientation in the first test. Therefore, a second test was performed to evaluate the sign support in an end-on (90 degree) orientation, which is representative of the sign being rotated out of view when not in use. As summarized in Table 3, the temporary sign support performed acceptably and met all of the required evaluation criteria.

Having successfully met the impact performance requirements of *NCHRP Report 350*, the new perforated square steel tube sign support system with diagonal braces is considered suitable for implementation as a temporary sign support. The sign support system was successfully tested with 4 ft × 4 ft × ½-inch thick plywood sign substrate. Because a plywood sign panel is considered more critical from an impact performance standpoint because of its greater weight, the successful testing with the plywood substrate is considered sufficient for acceptance of a comparably sized aluminum sign substrate or other lightweight substrate (e.g., corrugated plastic) on the same sign support frame.

Use of perforated steel tubing makes the frame lightweight (compared to wooden construction) and easy to assemble. The galvanized steel provides good durability and resistance to environmental attack without the need for painting, which is a maintenance requirement for wooden systems. The vertical sleeves incorporated into the design provide a degree of height adjustability to accommodate varying site conditions such as placement on a cross slope. The use of “rigid” sign substrates (i.e., plywood and aluminum) makes the system stiffer and more durable. In addition to the impact performance benefits, the incorporation of diagonal bracing into the frame structure provides inspectors with a readily identifiable means of differentiating this system from a previously tested system that is constrained to use with corrugated plastic sign substrates.

**Table 2. Performance Evaluation Summary for NCHRP Report 350 Test 3-71 on the Temporary Sign Supports (Head-On).**

Test Agency: Texas Transportation Institute

Test No.: 463849-1

Test Date: 2009-05-28

**NCHRP Report 350 Test 3-71 Evaluation Criteria**

*Test Results*

*Assessment*

Structural Adequacy

B. *The test article should readily activate in a predictable manner by breaking away, fracturing, or yielding.*

The first temporary sign support readily activated as designed by slipping yielding to the vehicle.

Pass

Occupant Risk

D. *Detached elements, fragments, or other debris from the test article should not penetrate or show potential for penetrating the occupant compartment, or present an undue hazard to other traffic, pedestrians, or personnel in a work zone. Deformations of, or intrusions into, the occupant compartment that could cause serious injuries should not be permitted.*

The detached elements did not penetrate or show potential to penetrate the occupant compartment. The support rode along with the vehicle and did not present undue hazard to others in the area. The windshield damage was not associated with the initial impact with the first support, but occurred after contact with the second support accelerated the first support into the windshield.

Pass

E. *Detached elements, fragments, or other debris from the test article, of vehicular damage should not block the driver's vision or otherwise cause the driver to lose control of the vehicle.*

No detached elements obstructed the driver's view.

Pass

F. *The vehicle should remain upright during and after collision although moderate roll, pitching, and yawing are acceptable.*

The 820C vehicle remained upright during and after the collision event.

Pass

H. *Occupant impact velocities should satisfy the following:*

*Occupant Velocity Limits (ft/s)*

<i>Component</i>	<i>Preferred</i>	<i>Maximum</i>
<i>Longitudinal</i>	<i>9.8</i>	<i>16.4</i>

No occupant impact occurred during the initial contact with the first sign support.

Pass

I. *Occupant ridedown accelerations should satisfy the following:*

*Occupant Ridedown Acceleration Limits (G)*

<i>Component</i>	<i>Preferred</i>	<i>Maximum</i>
<i>Longitudinal and lateral</i>	<i>15</i>	<i>20</i>

No occupant impact occurred during the initial contact with the first sign support.

Pass

Vehicle Trajectory

K. *After collision, it is preferable that the vehicle's trajectory not intrude into adjacent traffic lanes.*

The 820C vehicle did not intrude into adjacent traffic lanes.

Pass\*

N. *Vehicle trajectory behind the test article is acceptable.*

The 820C vehicle came to rest behind the original positions of the test articles.

Pass

\*Criterion K is preferable, not required.

**Table 3. Performance Evaluation Summary for NCHRP Report 350 Test 3-71 on the Temporary Sign Supports (End-On).**

Test Agency: Texas Transportation Institute

Test No.: 463849-2

Test Date: 2009-07-28

<b>NCHRP Report 350 Test 3-71 Evaluation Criteria</b>	<b>Test Results</b>	<b>Assessment</b>									
<u>Structural Adequacy</u>											
B. <i>The test article should readily activate in a predictable manner by breaking away, fracturing, or yielding.</i>	The temporary sign support readily activated as designed by yielding to the vehicle.	Pass									
<u>Occupant Risk</u>											
D. <i>Detached elements, fragments, or other debris from the test article should not penetrate or show potential for penetrating the occupant compartment, or present an undue hazard to other traffic, pedestrians, or personnel in a work zone. Deformations of, or intrusions into, the occupant compartment that could cause serious injuries should not be permitted.</i>	The detached elements did not penetrate or show potential to penetrate the occupant compartment. The support rode along with the vehicle and did not present undue hazard to others in the area. No deformation of the occupant compartment occurred.	Pass									
E. <i>Detached elements, fragments, or other debris from the test article, of vehicular damage should not block the driver's vision or otherwise cause the driver to lose control of the vehicle.</i>	No detached elements obstructed the driver's view.	Pass									
F. <i>The vehicle should remain upright during and after collision although moderate roll, pitching, and yawing are acceptable.</i>	The 820C vehicle remained upright during and after the collision event.	Pass									
H. <i>Occupant impact velocities should satisfy the following:</i> <table border="1" data-bbox="243 911 1010 1026"> <thead> <tr> <th colspan="3">Occupant Velocity Limits (ft/s)</th> </tr> <tr> <th>Component</th> <th>Preferred</th> <th>Maximum</th> </tr> </thead> <tbody> <tr> <td>Longitudinal</td> <td>9.8</td> <td>16.4</td> </tr> </tbody> </table>	Occupant Velocity Limits (ft/s)			Component	Preferred	Maximum	Longitudinal	9.8	16.4	Longitudinal impact velocity was 7.9 ft/s.	Pass
Occupant Velocity Limits (ft/s)											
Component	Preferred	Maximum									
Longitudinal	9.8	16.4									
I. <i>Occupant ridedown accelerations should satisfy the following:</i> <table border="1" data-bbox="243 1060 1010 1175"> <thead> <tr> <th colspan="3">Occupant Ridedown Acceleration Limits (G)</th> </tr> <tr> <th>Component</th> <th>Preferred</th> <th>Maximum</th> </tr> </thead> <tbody> <tr> <td>Longitudinal and lateral</td> <td>15</td> <td>20</td> </tr> </tbody> </table>	Occupant Ridedown Acceleration Limits (G)			Component	Preferred	Maximum	Longitudinal and lateral	15	20	Longitudinal occupant ridedown acceleration was -1.3 G, and lateral occupant ridedown acceleration was -0.3 G.	Pass
Occupant Ridedown Acceleration Limits (G)											
Component	Preferred	Maximum									
Longitudinal and lateral	15	20									
<u>Vehicle Trajectory</u>											
K. <i>After collision, it is preferable that the vehicle's trajectory not intrude into adjacent traffic lanes.</i>	The 820C vehicle did not intrude into adjacent traffic lanes.	Pass*									
N. <i>Vehicle trajectory behind the test article is acceptable.</i>	The 820C vehicle came to rest behind the installation.	Pass									

\*Criterion K is preferable, not required.

## **CHAPTER 3: AASHTO SIGN SHEETING MATERIAL SPECIFICATION**

### **INTRODUCTION**

In 2008, the AASHTO Subcommittee on Materials decided to develop a sign sheeting material specification different from ASTM D4956. The decision was based on the states' need for a sign sheeting material specification that better represented the nighttime drivers' needs than the status quo, which has been ASTM D4956. At the same time, TxDOT was reviewing their sign sheeting specification, DMS-8300. TxDOT took a leadership position on the development of an AASHTO sign sheeting material specification. This project provided a way to provide support to the AASHTO task group responsible for developing a new sign sheeting material specification.

The specific activities that were conducted as part of this research were to host an AASHTO sign sheeting demonstration and to develop recommendations for retroreflectivity levels that would better represent nighttime drivers' needs than the retroreflectivity tables in ASTM D4956. The remainder of this chapter describes these activities. The AASHTO sign sheeting material specification that resulted from this work is shown in Appendix E.

### **SIGN SHEETING DEMONSTRATION**

On May 21, 2009, a nighttime sign sheeting demonstration was conducted at the Texas A&M University Riverside Campus. The objective was to have the AASHTO task group convene to work on the AASHTO specification as well as conduct a nighttime demonstration of different sign sheeting materials. TTI hosted the meeting and demonstration. At the time of the meeting, the draft AASHTO specification was on draft number four and included four sheeting types. The sheeting types were based on retroreflectivity tables that were developed from an idea initially proposed by the Ohio DOT in the ASTM D04.38 Task Group 01 approximately five years ago. Table 4 shows the materials used by the AASHTO class at the time of the demonstration.

**Table 4. Retroreflective Materials Used in Demonstration.**

<b>AASHTO CLASS</b>	<b>MATERIAL TYPE</b>
A	NCI – High Intensity Beaded
B	3M High Intensity Prismatic
B	Avery Dennison Prismatic 6500
B	Avery Dennison Prismatic 7500
C	Avery Dennison Prismatic 9500
D	3M Diamond Grade Cubed

The attendees viewed side-by-side signs from five different vehicles, and a large truck provided by TxDOT. The vehicles were instructed not to stop. The attendees simply noted whether they preferred the left sign, the right sign, both, or neither. They were instructed to consider the appearance as a function visibility (legibility, brightness, contrast glare). After the data were collected, the attendees were provided information that included each type of material on each sign.

The legend on each sign was made with a black 10-inch Landolt Ring, a standardized symbol used for testing vision. The Landolt Ring consists of a ring that has a gap, looking similar to the letter C. The stroke width and the gap width are 1/5 of the diameter. The Landolt Ring was provided as a way to standardize the distance at which the attendees assessed legibility.

The evaluations were completed in passenger cars or pick-up trucks (with low-beam and high-beam illumination). There were four attendees per vehicle. The only exception was a large heavy vehicle rig supplied by TxDOT. Each attendee was also able to view the sign demonstration from the heavy vehicle rig perspective as well (with low-beam illumination).

The results were not meant to be statistically analyzed and reported, but they were tabulated to assess the viability of the then current draft AASHTO specification. The draft AASHTO types were first aggregated across vehicle type and compared. The results are described below.

When A was compared to B, 96 percent of responses (n=28) rated B as better than A. When A was compared to C, 86 percent of responses (n=14) rated C as better than A. When A was compared to D, 93 percent of responses (n=26) rated D as better than A.

When B was compared to C, 18 percent of responses (n=28) rated C as better than B. Half of the responses rated the materials as equal while 32 percent of responses rated B better than C.



B and C combinations were shown twice—once with 3M HIP and AD9500 and once with AD7500 and AD9500. The 3M HIP and AD9500 results were equal (8 times), 3M HIP favored (5 times), and AD9500 favored (1 time). For the AD7500 and AD9500 comparison, the results were equal (6 times), AD7500 favored (4 times), and AD9500 favored (4 times).

Considering all the B pairings (4 combinations resulting in n=56), 63 percent rated them equal, 37 percent unequal. For the 37 percent unequal response, the discrepancy occurs when 3M HIP was compared to AD6500 and AD7500. In three pairings of 3M HIP versus either AD6500 or AD7500 (n=42), they were rated equal 57 percent of the time but when they were rated different, the AD6500 or AD7500 were rated better than 3M HIP 83 percent of the time (n=18). When AD6500 and AD7500 were paired, they were rated as equal 78 percent of the time.

When B was compared to D, 43 percent of responses (n=28) rated D as better than B and 43 percent of responses rated the materials as equal. When C was compared to D, 52 percent of responses (n=27) rated D as better than C and 48 percent of responses rated the materials as equal.

It was initially thought that the low “percent correct response” of 18 percent for the comparison of B to C might be acceptable since a key difference between B and C in the AASHTO draft 4 specification was the observation angle requirements. Grades C and D can be distinguished from Grades A and B by having substantially higher observation angle requirements at 1.0 degree. In theory, the need for this distinction would be demonstrated by the evaluations from the large truck. However, the responses from the large truck when B and C materials were paired were not as expected. Three observations were made with these pairs, and they were rated equal twice and C was chosen better B once. Grades D and B were seen by six observers from the large truck. In this case, they were rated equal twice, D was rated better than B twice, and B was rated better than D twice. All the observations from the large truck were made with the headlamps in the low-beam position.

Under high-beam illumination, the signs with black legend on white background were rated as being equal or at least undistinguishable more often than under low-beam illumination. At the greatest extreme, the A-D combination had mixed results. While none of the nine participants viewed the signs as equal, five preferred D and four preferred A (all four commenting that Class D was too bright or too glaring). In an A-C combination, seven

participants preferred C, while three preferred A, and two reported them as equal. Again, over-brightness or glare was often cited as remarks on the data sheet. There were two combinations of B-D and most of the participants felt these were equal (15 of 24) with four preferring D and five preferring B. Finally, in the case of B-B combinations, there were 18 of 24 that thought they were equal and still a fair amount of remarks concerning over-brightness.

## RECOMMENDED RETROREFLECTIVITY LEVELS

The final coefficient of retroreflection values for the ninth version of the AASHTO specification were based on the findings of the demonstration as well as continued discussions (see Table 5). They are based on a compilation of discussions, experiences, and findings from research as well as the AASHTO sign demonstration described previously. They are still based on mathematical relationships (see Table 6) that emphasize the need for more retroreflection as the Type designation increases from A to D (with a focus on the 0.5 degree observation angle). The instructions when no rotation angle is specified are to take measurements at 0 and 90 degrees and then average the measured values. Compliance with the minimum coefficient of retroreflection for the 1.0° observation angle is required for Types C and D. Compliance with the minimum coefficient of retroreflection for the 1.0° observation angle is required for Types A and B only when specified by the end user. Appendix E shows the complete AASHTO specification that was submitted for ballot.

**Table 5. Coefficient of Retroreflection Values for AASHTO Ballot (cd/lx/m<sup>2</sup>).**

<i>Observation Angle</i>	<i>Entrance Angle</i>	<i>AASHTO Sheeting Type</i>			
		<i>A</i>	<i>B</i>	<i>C</i>	<i>D</i>
<i>0.2</i>	<i>-4</i>	<i>240</i>	<i>335</i>	<i>580</i>	<i>580</i>
<i>0.2</i>	<i>30</i>	<i>120</i>	<i>120</i>	<i>200</i>	<i>200</i>
<i>0.5</i>	<i>-4</i>	<i>95</i>	<i>135</i>	<i>235</i>	<i>465</i>
<i>0.5</i>	<i>30</i>	<i>50</i>	<i>45</i>	<i>80</i>	<i>160</i>
<i>1.0</i>	<i>-4</i>	<i>4.5</i>	<i>15</i>	<i>60</i>	<i>120</i>
<i>1.0</i>	<i>30</i>	<i>2.5</i>	<i>5.5</i>	<i>20</i>	<i>40</i>

**Table 6. Mathematical Relations for AASHTO Types.**

<i>Obs. Angle</i>	<i>Entr. Angle</i>	<i>AASHTO Sheeting Type</i>			
		<i>A</i>	<i>B</i>	<i>C</i>	<i>D</i>
0.2	-4	$a * 2.5$	$b * 2.5$	$c * 2.5$	$c * 2.5$
0.2	30	$a * 1.25$	$b * 0.875$	$c * 0.875$	$c * 0.875$
0.5	-4	$a$	$b = \text{Sq. Root } 2 * a$	$c = \text{Sq. Root } 3 * b$	$d = \text{Sq. Root } 4 * c$
0.5	30	$a * 0.5$	$b * 0.35$	$c * 0.35$	$d * 0.35$
1.0	-4	$a * 0.05$	$b * 0.125$	$c * 0.25$	$d * 0.25$
1.0	30	$a * 0.05$	$b * 0.04375$	$c * 0.0875$	$d * 0.0875$



## **CHAPTER 4: SIGN SHEETING STUDY: DESCRIPTION**

### **INTRODUCTION**

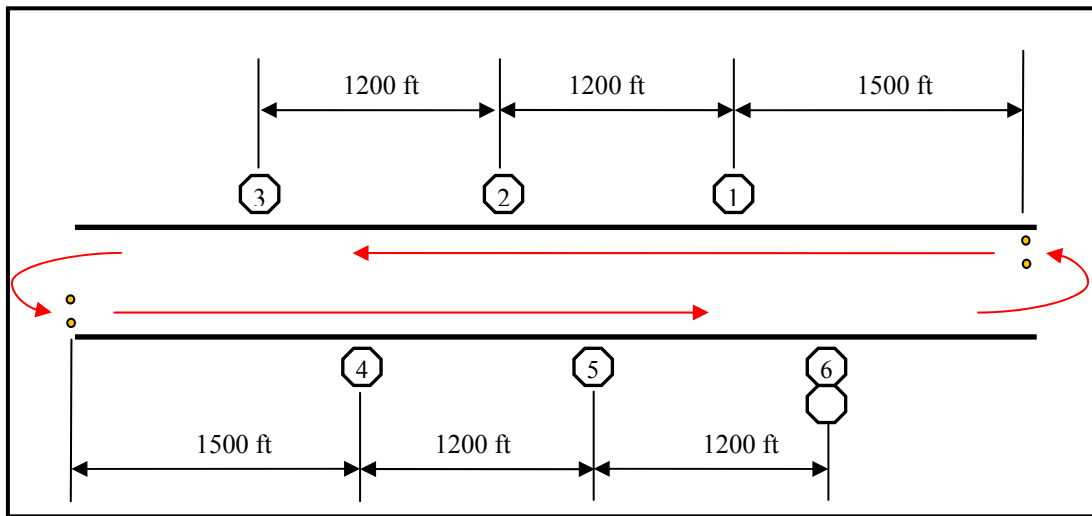
This research activity was partly a result of the work described in the previous chapter concerning the development of the AASHTO sign sheeting material specification. There were signing concerns prior to the work on the AASHTO specification regarding the overbrightness of signs on rural low volume highways, the brightness uniformity of letters on positive contract signs and, to some extent, the role of contrast in terms of legibility on positive contrast signs. The AASHTO specification did not fully address these issues, and therefore it was decided that additional research was needed. This decision was not made until mid-way through the project, and in order to address the issues, the work was split into two phases. Phase I, which was conducted in year one, focused on black on white signs, their orientation, and whether their brightness actually degrades performance on low volume rural roadways when vehicles commonly drive with high beam illumination. Phase II will be conducted in year two.

The Phase I study was conducted on a closed course at the Texas A&M University's Riverside Campus. The course was set up along the west runway outlined in Figure 17.



**Figure 17. Riverside Campus.**

Seven signs were positioned along the western runway, as shown in Figure 18. There were five sign locations with individual signs, as indicated by 1 through 5 in Figure 18. A sixth location, as indicated by the 6 in Figure 18, had a side-by-side sign comparison. The sign locations did not change throughout the experiment; however, the signs at each location did change. The signs were placed approximately 1,200 ft apart, which provided enough time to comment about the sign(s) at each sign location prior to being able to read the sign(s) at the next sign location.



**Figure 18. Sign Layout.**

The course was split into two different legs. Two cones, represented by the yellow dots in Figure 18, were placed at the start of each leg of the course. At each set of cones, a researcher within the study vehicle reset a distance measuring instrument (DMI). The researcher then used the DMI to record the distance of each observation made by the study participants. The difference to each observed sign would later be calculated by subtracting the recorded DMI distances from the total length of each leg of the study course. Each study participant completed at least complete 10 laps of the entire course.

## **SIGN DESIGN**

The signs used in this study were 24-inch white octagons with a black legend and were installed as a shoulder-mounted sign, with the bottom of the sign at 7 ft above the roadway surface. The lateral offset was approximately 12 ft from the inside of edge of the sign to the outside edge of the travel lane. Signs were constructed of various retroreflective sheeting types,

and applied to aluminum substrate cut in the shape of an octagon. Six retroreflective sheeting types were tested with five of the materials constructed using microprismatic design and one material constructed using enclosed glass beads. Table 7 shows the sheeting types used. The sheeting types were defined both by their ASTM designation and their TxDOT specification.

**Table 7. Sheeting Types Used.**

<b>Code</b>	<b>ASTM D4956 Type</b>	<b>TxDOT DMS-8300 Type</b>
R2	III, IV, X	C, D
R3	XI	D
R4	III, IV	C, D
R6	IX	D
R7	VIII	D
R9	III	C

The legend or target on each sign was a Landolt Ring, a standardized symbol used for testing vision, as shown in Figure 19. The Landolt Ring consists of a ring that has a gap, looking similar to the letter C, so the Landolt Ring has also been referred to as the Landolt C. The stroke width and the gap width are 1/5 of the diameter. The Landolt C was either 10 inches or 6 inches, and the gap was positioned at four locations (left, right, bottom, and top). A 10-inch Landolt C had a 2-inch wide stroke width with a 2-inch gap.



**Figure 19. Example of a Test Sign with a Landolt C**

With the six sign locations, at five locations the signs were viewed independently and at one location there was a side-by-side comparison. For the five independent signs, the subject indicated the direction of the gap when they could first see the opening and the distance was recorded by the researcher. For the side-by-side comparison, the subject compared the two signs that had the same Landolt C orientation and indicated which sign they thought was better.

## **TEST SUBJECTS**

Thirteen participants completed the study. Before beginning, the researcher tested each participant's visual acuity and color blindness and gave them a description of the study. The Snellen Eye Chart was used to report the visual acuity of each participant, and the Ishihara Test was used to record whether a test participant was colorblind. The study participants were all younger drivers ranging from 18 to 50 years old with an average age of 30. Six of the participants were male, and seven were female. Visual acuity varied from 20/13 to 20/25 with an average of 20/19, and none of the subjects were colorblind.

## **VEHICLE**

Participants in the study drove a TTI-owned 2008 Ford Explorer. The height of the headlamps above the road surface was 40 inches, and the height of the participant's eyes was approximately 64 inches. During the study, the vehicle was not used for any other purposes at anytime. This ensured the illuminance provided by the headlamps, the aim of the headlamps, and cleanliness of the headlamps remained the same throughout the experiment.

The illuminance readings of the headlamps of the study vehicle were measured at the center of the sign at four longitudinal distances and two lateral distances using the high and low beams. The four longitudinal distances were 120, 200, 240, and 400 ft and represented legibility indices of 20 ft per inch and 40 ft per inch for the two legend heights, 6 inches and 10 inches. The two lateral distances represented the location of the signs, 19.75 and 23.75 ft, and are based on a vehicle centered in a 12.5-ft wide lane with a 12.5-ft wide offset to the edge of a 2-ft wide sign. The lateral distance of 23.75 ft was only used with the side-by-side comparison. Figure 20 displays a graph of the headlamp illuminance for the side-by-side comparison. The values for the four longitudinal distances are also provided in Table 8 and Table 9.



The sign luminance was also measured, using a CCD-based photometer positioned in the driver's seat of the test vehicle and located as close to the driver's eye position as possible. Table 8 and Table 9 list the luminance readings for each of the signs at the indicated distances of measurement. Figure 21 and Figure 22 show plots of the low beam and high beam data for the near offset.

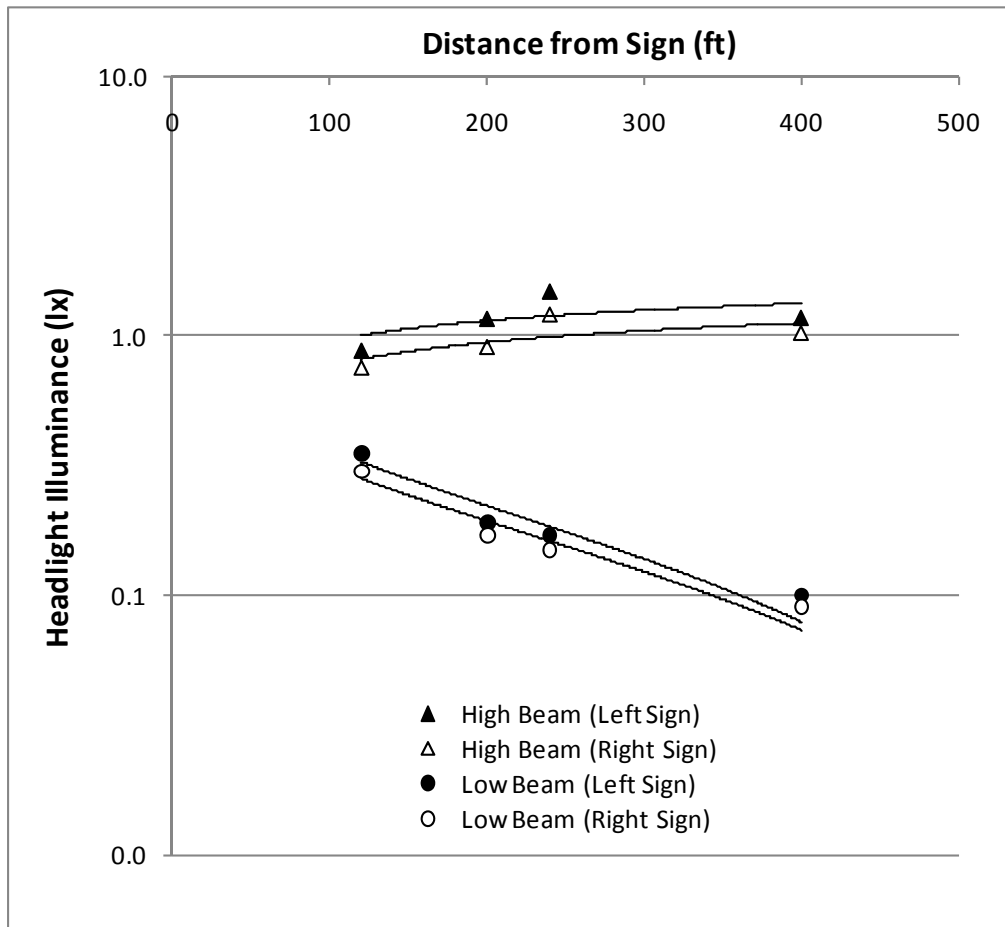


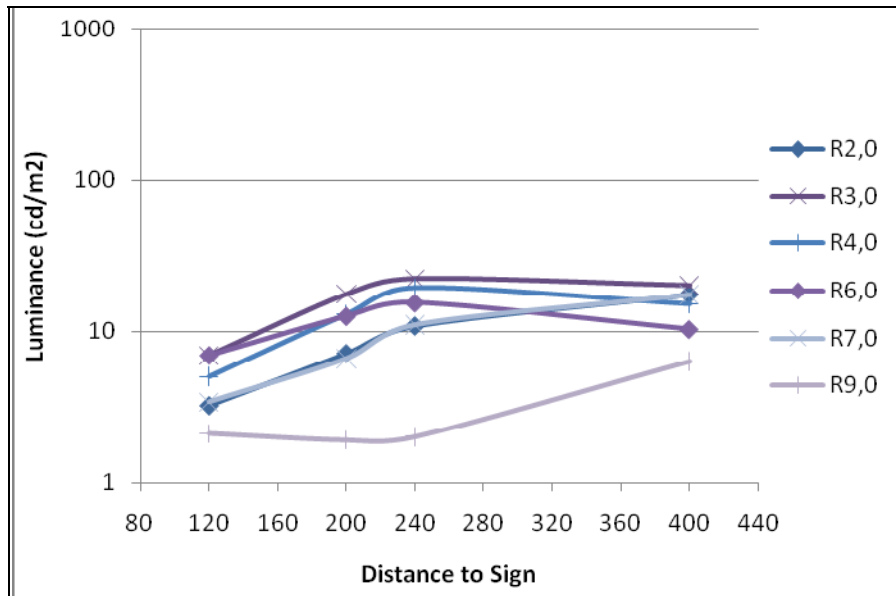
Figure 20. Test Vehicle Headlight Illuminance.

**Table 8. Photometric Data at 200 and 120 ft.**

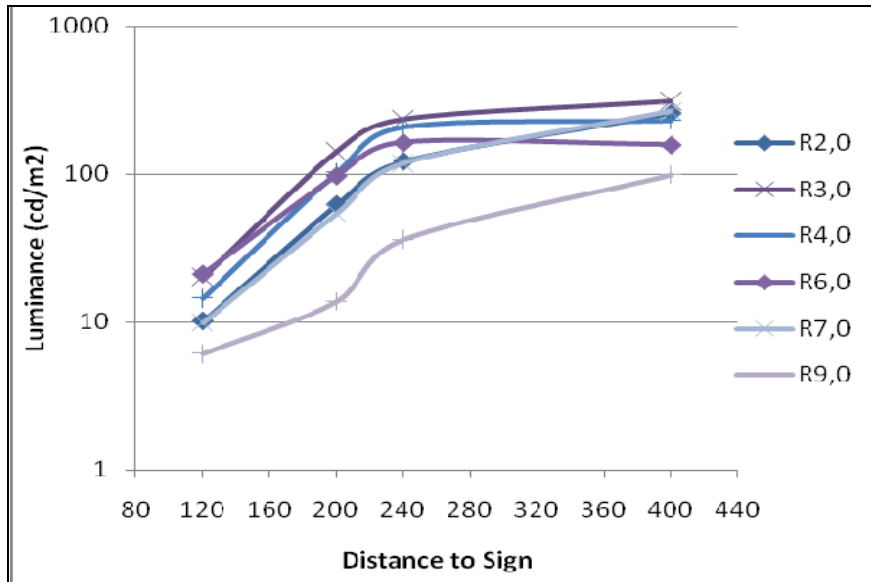
Distance	Longitudinal (ft)	200				120				
		Lateral (ft)	19.75	23.75	19.75	23.75	19.75	23.75	19.75	23.75
Headlamps	Beam	Low		High		Low		High		
	Reading (lux)	0.19	0.17	1.16	0.9	0.35	0.3	0.88	0.75	
Sheeting	Orientation	Luminance (cd/m <sup>2</sup> )		Luminance (cd/m <sup>2</sup> )		Luminance (cd/m <sup>2</sup> )		Luminance (cd/m <sup>2</sup> )		
		R2	0	7.1	7.0	61.9	44.2	3.2	3.0	10.1
	R2	45	8.3	7.8	66.3	45.1	3.1	3.4	9.6	10.8
	R2	90	6.5	6.9	49.1	43.3	3.3	3.3	10.0	9.6
	R3	0	17.6	16.4	142.4	105.3	6.9	7.1	20.2	20.7
	R3	45	16.9	16.6	133.7	105.4	10.4	9.7	30.8	28.3
	R3	90	15.5	15.3	122.8	98.7	7.9	8.8	22.8	24.7
	R4	0	13.0	12.9	102.5	79.0	5.0	5.6	14.5	16.3
	R4	45	12.9	13.0	101.0	81.8	4.9	5.6	14.1	16.5
	R4	90	13.0	13.0	102.9	82.4	5.1	5.7	15.5	16.8
	R6	0	12.6	12.1	97.5	76.5	6.9	7.7	21.0	22.8
	R6	45	13.3	12.8	113.4	85.3	5.9	6.3	17.8	18.2
	R6	90	13.2	12.6	105.1	81.3	6.6	6.8	20.0	20.1
	R7	0	6.6	6.5	54.1	37.7	3.4	3.1	9.9	9.0
	R7	45	8.1	8.8	55.0	45.8	2.8	3.0	8.1	8.1
	R7	90	8.0	7.8	56.4	45.6	3.9	3.7	11.5	10.9
	R9	0	1.9		13.8		2.1		6.1	

**Table 9. Photometric Data at 400 and 240 ft.**

Distance	Longitudinal (ft)	400				240					
		Lateral (ft)	Beam Reading (lux)	Low	High	Lateral (ft)	Beam Reading (lux)	Low	High		
		19.75	0.1	0.09	1.17	23.75	0.17	0.15	1.47	23.75	1.2
		Sheeting	Orientation	Luminance (cd/m <sup>2</sup> )		Luminance (cd/m <sup>2</sup> )		Luminance (cd/m <sup>2</sup> )		Luminance (cd/m <sup>2</sup> )	
R2	0		0	17.5	16.2	256.9	229.6	10.8	9.7	121.5	91.1
R2	45		45	18.0	17.6	274.9	247.0	12.3	11.0	145.6	123.2
R2	90		90	16.0	15.4	249.4	219.1	10.1	10.1	108.4	95.5
R3	0		0	20.1	19.2	310.3	271.9	22.3	19.4	234.7	177.6
R3	45		45	19.7	19.8	303.9	284.8	21.1	19.5	225.5	183.6
R3	90		90	21.7	20.5	334.4	305.5	21.1	19.5	234.5	185.5
R4	0		0	15.2	13.8	231.2	195.1	19.5	17.3	209.3	163.5
R4	45		45	15.5	14.3	237.0	199.6	18.8	17.1	204.5	158.6
R4	90		90	15.2	14.2	233.1	197.4	19.1	17.5	204.1	159.9
R6	0		0	10.3	9.8	157.9	137.1	15.5	13.8	163.8	126.3
R6	45		45	11.2	10.8	176.1	154.5	17.1	15.1	187.2	143.5
R6	90		90	11.1	10.6	170.6	149.7	16.6	14.6	177.7	135.4
R7	0		0	17.4	16.6	265.5	234.0	11.0	10.0	118.4	95.2
R7	45		45	19.7	18.7	299.0	258.9	13.7	13.4	133.0	108.5
R7	90		90	15.9	15.5	241.4	215.2	10.0	9.5	103.6	81.1
R9	0		0	6.3		99.1		2.0		36.2	



**Figure 21. Luminance Levels under Lowbeam Illumination (19.75 ft Offset).**



**Figure 22. Luminance Levels under Highbeam Illumination (19.75 ft Offset).**

## DATA COLLECTION

The data were collected in June 2009. The study participants arrived shortly before they would begin the study, which lasted approximately an hour. A researcher met the subject at the entrance of Riverside Campus and directed the participant to the study induction office where the pre-study activities were conducted. The participants then drove the study vehicle to the study course area and completed a practice run to familiarize them with the course. On the way to the study course, the participants were instructed to set the cruise control to approximately 40 mph. This would be the speed while driving the course. The participants were then given a chance to ask any additional questions before beginning.

The participants completed 10 laps, viewing three sign locations consecutively. Before viewing each set of signs along each leg of the course, the participants aligned the vehicle between two traffic cones, and the researcher reset the DMI. Once the DMI was reset, the participants were asked if they had any questions or comments. After any questions were answered and comments recorded, they were instructed to start the next leg of a lap at their convenience. The participants accelerated from a stopped position between the traffic cones to 40 mph, and then reset the cruise control that was set during the practice run. They viewed three signs and then decelerated to complete a U-turn and realign with the cones. When the study participant completed all of the laps, they were instructed to return to the study induction office.

## RESULTS

Each participant viewed the six sign locations 10 times, creating 720 observations, 600 were single sign observations. It is important to note that the luminance changed as the participant approached the sign and the sign was read at the distance the individual participant could read it. This distance does not necessarily correspond to the minimum luminance required to read a sign at the specific distance, as it was believed that at some higher level of luminance the sign may become too bright and the legend would be washed out, thus reducing legibility distance.

Figure 23 displays a plot of the average legibility indices against the luminance provided by the sheeting material. As shown, the signs with the 6-inch legend were viewed at a smaller legibility index and with less luminance than the signs with the 10-inch legend for both high and low beams. Also, using high beams provides much more luminance but does not improve the legibility index, suggesting that the legibility index flattens out at a certain point and possibly begins to decline if a sign is too bright. These results should be considered preliminary as additional results will be obtained in the second phase of the study, which will be completed with white on green signs and will be conducted in the second year of the study. When all the data are available, the researchers will combine the data and complete a full analysis to establish recommendations for TxDOT's sign sheeting material specification.

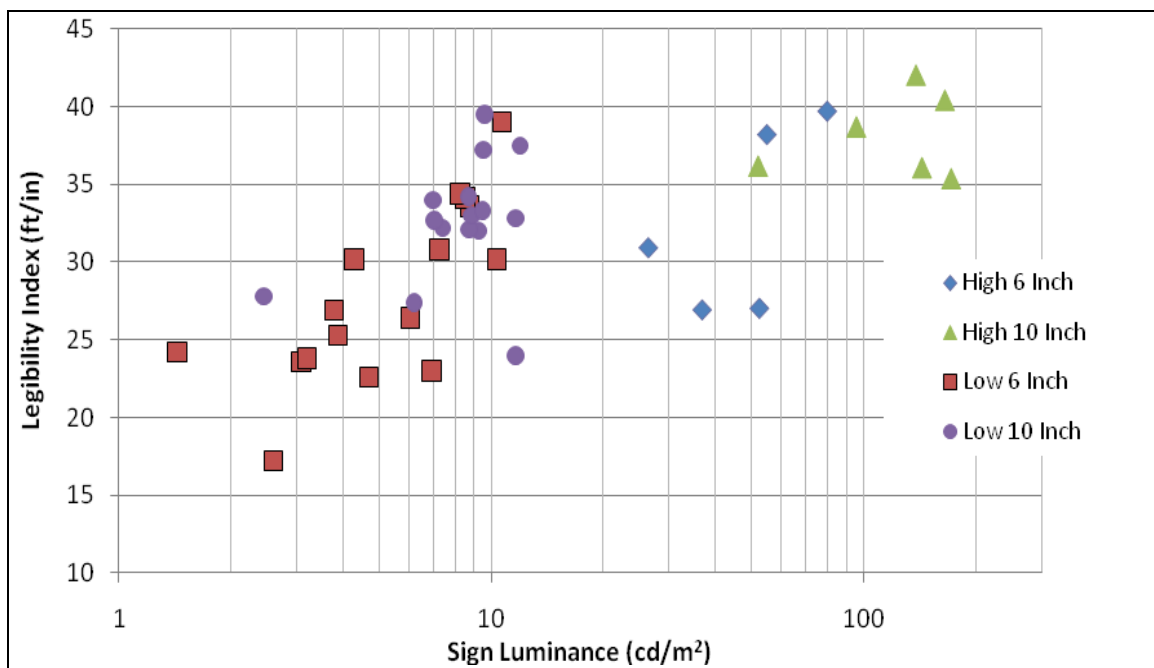


Figure 23. TxDOT Study Results.



## **CHAPTER 5: CONTINUED EVALUATION OF LEAD-FREE THERMOPLASTIC PAVEMENT MARKINGS**

This chapter provides an update to the evaluation of lead-free thermoplastic pavement markings that is continued from TxDOT research project 0-4701-5 (5). Relevant background and study design information from the previous report will be carried over to this document and updated to allow it to serve as a standalone document.

### **BACKGROUND**

The TxDOT departmental material specification (DMS) for thermoplastic pavement marking material is DMS-8220, Hot Applied Thermoplastic (updated May 2009). The last few updates to this specification have included changes to the requirements regarding the yellow pigment in thermoplastic pavement markings. The 2004 update of the document indicated that the yellow pigment, “*must be a heat-resistant medium chrome yellow or other approved heat-resistant pigment*” that is 10–15 percent by weight of the total material (12). The 2007 update of the document indicated that the yellow pigment, “*must be a heat-resistant, double-encapsulated medium chrome yellow or other approved heat-resistant pigment*” that is 5–10 percent by weight of the total material (13). The 2009 update of the document indicates that the yellow pigment, “*must be heat-resistant and weather-stable. The yellow pigment may be either a double-encapsulated medium chrome yellow or a lead-free, organic yellow pigment (C.I. Pigment Yellow 83, opaque version)*” that is a minimum of 5 percent by weight of the total material for the medium-chrome pigment or 1.5 percent for the lead-free pigment (14). The 2009 document also states to not mix pigment types within a batch and that alternate pigments other than those listed must be evaluated and approved prior to use in the formulation. The 2009 document also changed International Commission on Illumination (CIE) chromaticity coordinate requirements. The daytime coordinates were changed as indicated in Appendix F, and the document now includes nighttime CIE chromaticity coordinate requirements. The nighttime yellow CIE chromaticity coordinate requirements were based on those recommended by NCHRP Project 5-18 (15). The chromaticity coordinates for a material must fall within the box created by the requirements.

The chrome yellow pigment contains lead, but the lead is considered safe because it is encapsulated. Even so, Texas is in the minority of state transportation agencies that use a leaded pigment in the marking material specification. There are numerous reasons supporting the use of leaded pigments in yellow markings; the most significant is the concern that organic pigments do not provide sufficient yellow color to be perceived by drivers as yellow in all conditions.

The concern over the color performance of yellow pavement markings led to a research project sponsored by the National Cooperative Highway Research Program. NCHRP Project 5-18, Color Effectiveness of Yellow Pavement Marking Materials, evaluated many different aspects of yellow markings, including evaluations of driver recognition of various yellow pavement markings, field evaluations of yellow pavement marking materials, and developing recommendations for yellow pavement marking chromaticity coordinates (15). The recommendations from the research modified both the yellow and white nighttime chromaticity coordinate boxes, while the daytime chromaticity coordinate boxes remained unchanged. The modified nighttime chromaticity coordinate box can be seen in Table 10. The objective of these recommended nighttime chromaticity coordinate boxes is to reduce the confusion between white and yellow markings and to include the areas that the subjective testing indicated favorable color response.

**Table 10. NCHRP 5-18 Nighttime Chromaticity Coordinate Box Recommendations.**

White		Yellow	
x	y	x	y
0.45	0.42	0.53	0.47
0.41	0.40	0.49	0.44
0.43	0.38	0.50	0.42
0.47	0.40	0.51	0.40
0.46	0.42	0.57	0.43

## **STUDY DESIGN**

In the summer of 2007, TxDOT began experimenting with the use of lead-free thermoplastic pavement markings. In July 2007, TxDOT requested that TTI researchers assist in the evaluation of field applications of lead-free thermoplastic markings. Accordingly, TTI researchers observed the installation of lead-free thermoplastic pavement markings at the two sites. The first test deck was on US 79 in Franklin on a new seal coat surface treatment. The



second test deck was on SH 21 just east of the Brazos River, also on a new seal coat surface treatment.

The US 79 site included both lead-free and standard yellow thermoplastic materials that were installed on consecutive days in a two-way left-turn lane in the city. The SH 21 site consisted only of lead-free thermoplastic installed as the left edge line on a divided highway, transitioning to a double solid centerline on an undivided highway (see Figure 24). The US 79 section has an approximate average daily traffic (ADT) of 8000, and the SH 21 section has an approximate ADT of 12,000.



**Figure 24. SH 21 Lead-Free Thermoplastic Installation.**

At the end of summer in 2008, a third test deck was added to the continued evaluation of lead-free thermoplastic pavement markings. Test deck 3 was installed on SH 21 just east of Caldwell, Texas. The road surface was a new seal coat surface treatment, with approximately 12,000 ADT. Standard spray applied thermoplastic with Type II beads was installed along the road as part of the contract to resurface the road. A portion of road was left without edgeline markings so that the test markings could be installed. The test marking installed was a lead-free thermoplastic that was applied by ribbon extrusion. Two different sections were applied, one

section had a double drop of Type II and Type IV beads, and the second section had just Type II beads for comparison to the standard marking.

### Measurements

The attributes measured are 30 meter retroreflectivity, 30 meter nighttime color, and 45/0 daytime and nighttime color. Table 11 summarizes key elements of these measurements and the instruments used.

**Table 11. Lead-Free Yellow Thermoplastic Pavement Marking Measurements.**

Attribute	Measurement Geometry	Instrument	Description
Retro-reflectivity	30 meter	LTL-2000Y/LTL-2000SY	A measure of the amount of light retroreflected to the driver from the pavement marking.
Nighttime Color	30 meter	LTL-2000Y/LTL-2000SY	A measure of the nighttime color of the pavement marking as viewed by the driver.
	45/0	BYK Gardner Color Guide/ Hunterlab MiniScan XE Plus	A measure of color using Illuminant A and the standard color measurement geometry. The 2 degree standard observer was used for all measurements.
Daytime Color	45/0	BYK Gardner Color Guide/ Hunterlab MiniScan XE Plus	A measure of color using Illuminant D65 and the standard color measurement geometry. Both 2 degree and 10 degree standard observers were used.

All attributes, measurement geometries, and standard observers were measured at test decks 1 and 2 during each evaluation. At test deck 3 only retroreflectivity, 30 meter nighttime color, and 2 degree standard observer daytime color were measured. Two types of instruments are listed because new equipment was purchased just prior to the installation of test deck 3. All measurements after September 2008 were made using the new equipment.

The measurements were then compared to minimum retroreflectivity levels and color boxes where appropriate. The minimum retroreflectivity level of 175 mcd/m<sup>2</sup>/lux for yellow pavement markings is contained in Special Specification 8251, Reflectorized Pavement Markings with Retroreflective Requirements (16). Several different chromaticity coordinate boxes exist for pavement markings. The TxDOT chromaticity coordinate boxes for yellow

markings are contained in DMS-8220, Hot Applied Thermoplastic (14). The July 31, 2002, Final Rule by the FHWA, also established daytime (45/0) 2 degree standard observer and nighttime (30 meter) chromaticity coordinate boxes for traffic materials (17). Appendix F Table F1 and Table 10 provide the specific x and y values for these chromaticity coordinate boxes.

## RESULTS

A summary of the results is described in the following sections. Appendix F Table F2 through Table F7 provides the retroreflectivity and color measurements for the three test decks.

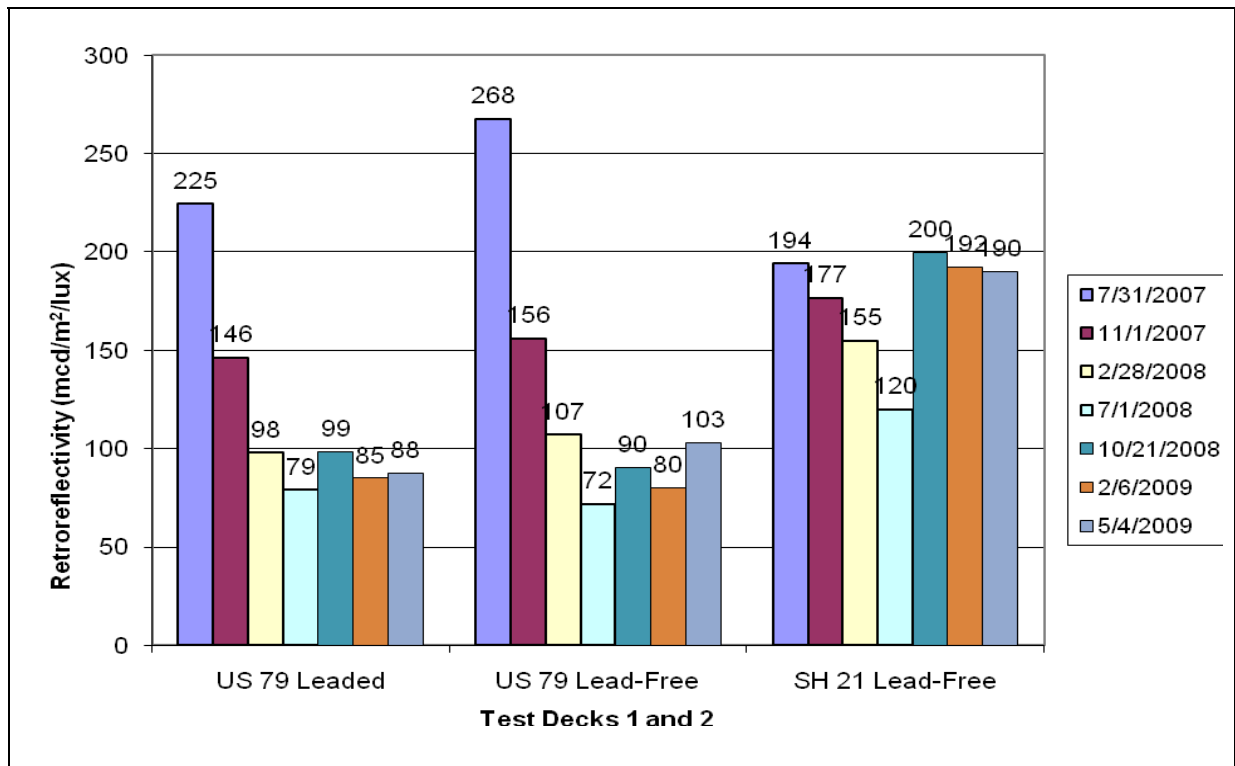
### Retroreflectivity

The retroreflectivity ( $R_L$ ) measurements at test decks 1 and 2 were initially made with an LTL-2000Y retroreflectometer that was borrowed from TxDOT. The initial measurements were made the day that the markings were applied to the roadway. The second through the fourth set of data were collected using an LTL-2000Y borrowed from the Federal Highway Administration. The fifth through the most recent set of data were collected using a new LTL-2000SY that TTI purchased. All retroreflectivity measurements on test deck 3 were made using the TTI LTL-2000SY. Figure 25 and Figure 26 display the average retroreflectivity values of each marking type on the three test decks.

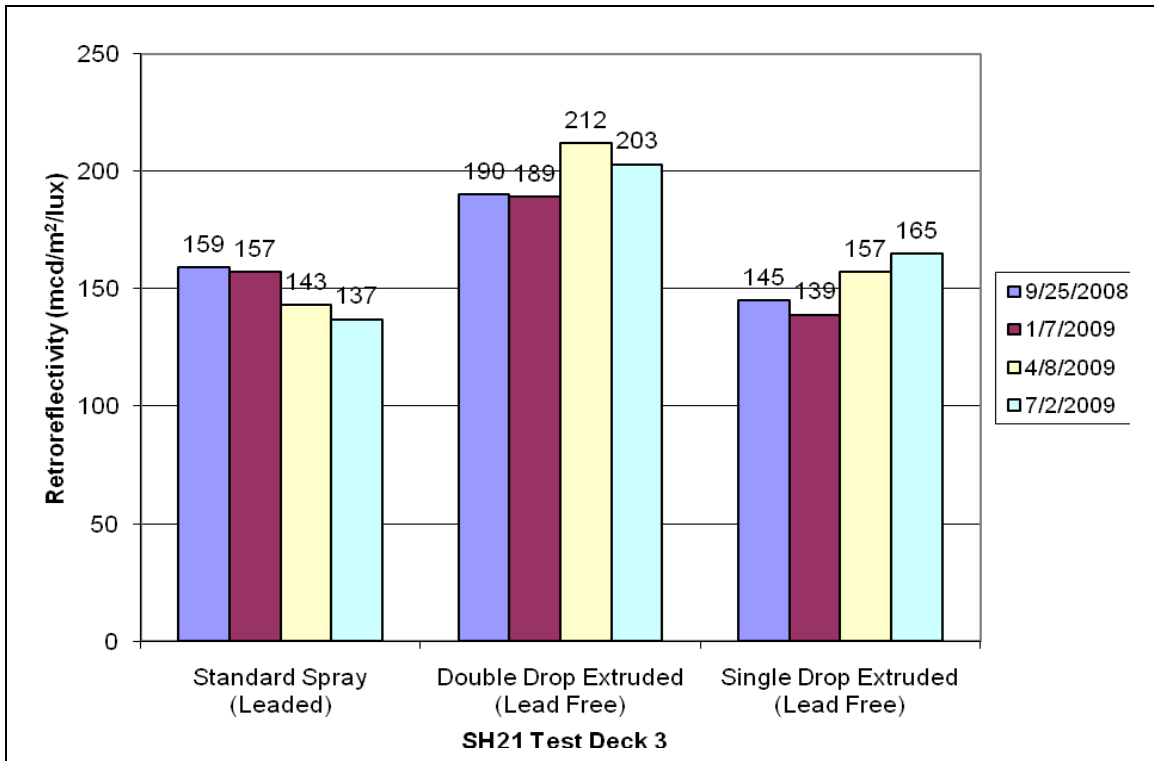
All of the initial measurements on both the leaded and lead-free materials of test deck 1 and 2 were above the 175 mcd/m<sup>2</sup>/lx minimum level required by TxDOT specification. Only the double drop lead-free extruded section on deck 3 was above the minimum install retroreflectivity level. The leaded section with the standard Type II beads and the lead-free section with the single drop of the standard Type II beads were slightly below the minimum installation value. It appears that the bead type(s) used has a larger impact on retroreflectivity than does the presence of lead in the yellow thermoplastic. It is worth noting that the markings measured on the pavement were applied to seal coat surface treatment. This surface represents a very rough pavement surface, which may have an impact on the measured retroreflectivity. However, there were no application sites included where the lead-free marking material was applied to a smoother pavement surface.

As seen in Figure 25 and Figure 26 the retroreflectivity at each location is somewhat variable as the markings aged. A greater decrease in retroreflectivity is observed at the US 79

site than at either of the SH21 sites. The ADT on US 79 is less than that of SH 21, but since the markings form a two-way left-turn lane, it is subject to more turning movements and traffic hits than the markings on SH 21. The leaded and lead-free markings on US 79 followed similar trends as the markings aged. The biggest thing to note for test decks 1 and 2 is the change in retroreflectivity values as the measuring equipment changed. All measurement procedures and calibration processes were the same between the measurement dates. During a comparison test between the TxDOT and the FHWA LTL-2000Y it was found that the FHWA device typically resulted in a lower retroreflectivity measurement than the TxDOT device (on average about 8 percent lower) (5). The new TTI LTL-2000SY was not able to be compared to the FHWA device, but it clearly looks like it too results in measurements that are higher than the FHWA device. Comparisons were made between the TTI LTL-2000SY and other TTI pavement marking retroreflectivity devices and the resulting retroreflectivity values were similar. The resulting retroreflectivity measurements from the FHWA LTL-2000Y appear to be lower than they should be due to the equipment itself.



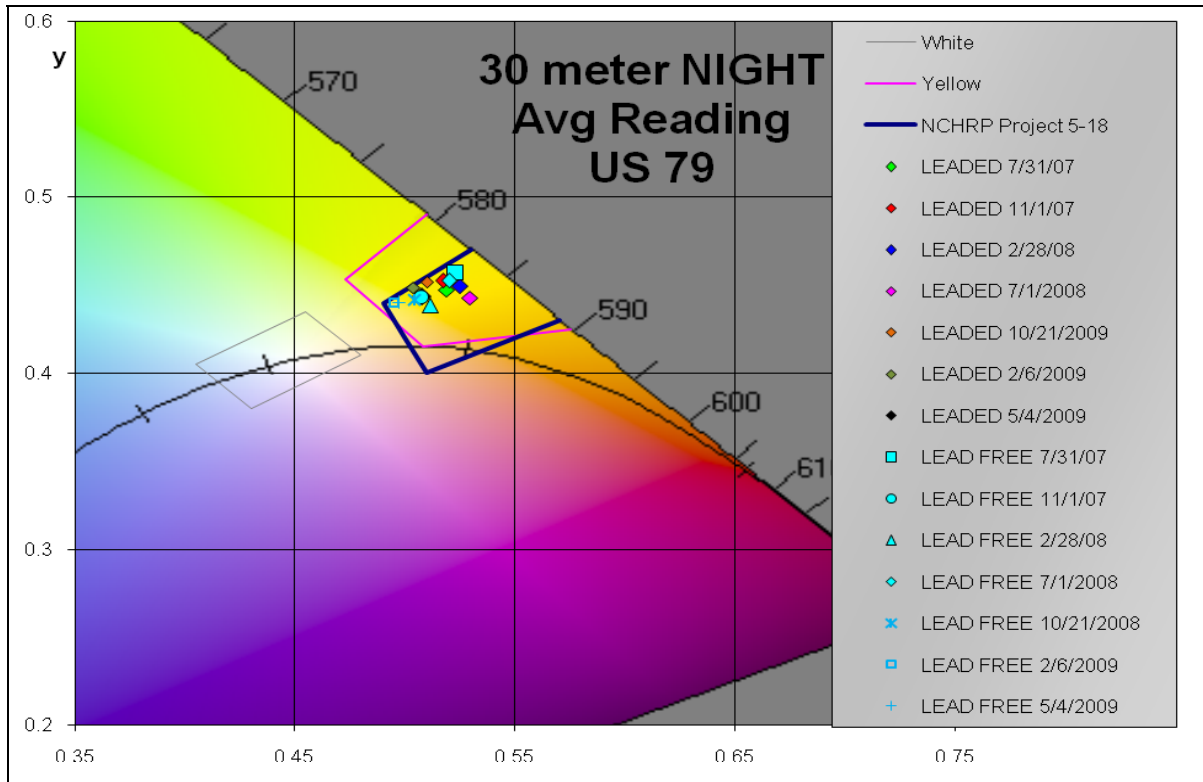
**Figure 25. Yellow Thermoplastic Retroreflectivity Summary (Decks 1 and 2).**



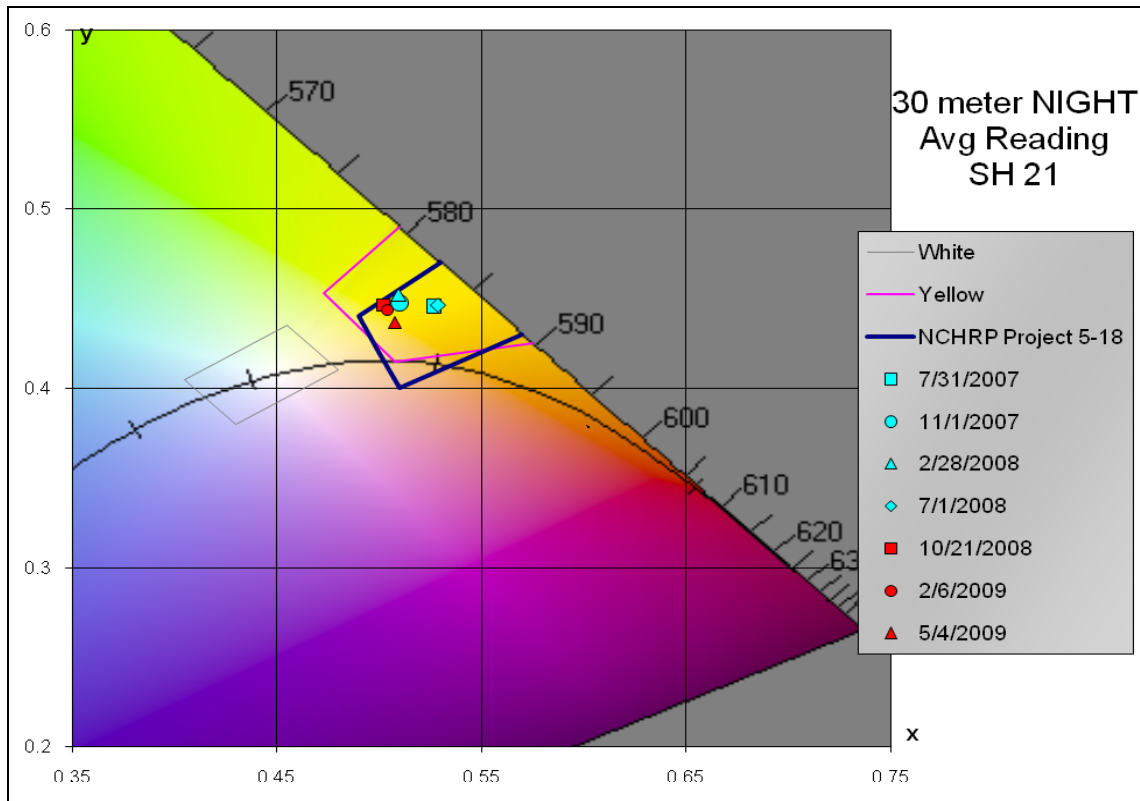
**Figure 26. Yellow Thermoplastic Retroreflectivity Summary (Deck 3).**

### **Color – 30 Meter**

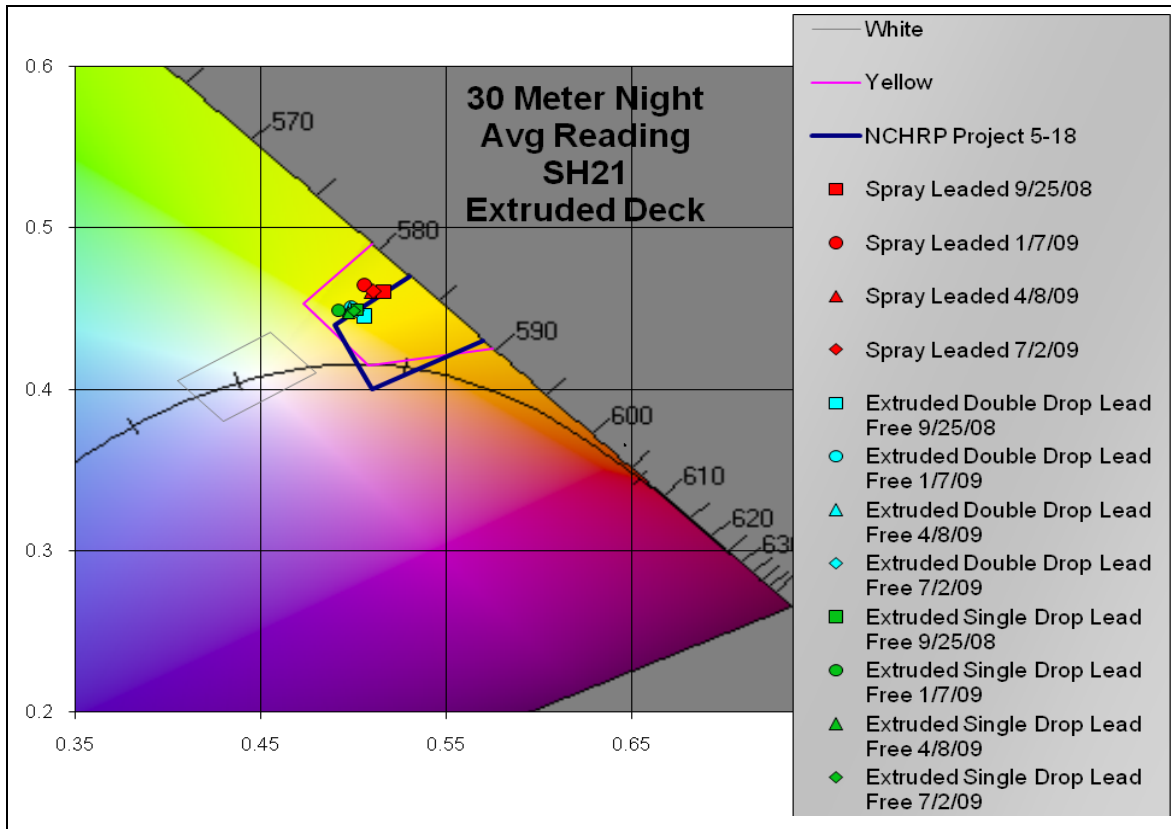
The average 30 meter color values from each data collection period were plotted against the x-y points defining the color box from the FHWA final rule on marking color. This color box is based on Illuminant A and a viewing geometry that is the same as the 30 meter retroreflectivity geometry. The NCHRP recommended color box, which is also the 30 meter color box for TxDOT, is also illustrated to show the difference. Figure 27, Figure 28, and Figure 29 illustrate the plot of the average color points for the color measurements with the LTL-2000 devices at the three sites. Unlike the retroreflectivity measurements, 30 meter color comparisons resulted in little difference between the three different LTL-2000 devices. All of the average measurements from each data collection period on both the leaded and lead-free markings are within the FHWA color box. At sites 1 and 2 all the measurements were also within the NCHRP color box. The third site resulted in measurements that were right on the edge of the NCHRP color box. It appears from all three sites that as the markings age (both the leaded and the lead-free) they are trending toward the white area of the color box. The leaded marking at sites 1 and 3 were both more saturated in color initially and over time than were the lead-free markings.



**Figure 27. Avg 30 Meter Night Color of Leaded and Lead-Free Thermoplastic at US 79 Site.**



**Figure 28. Avg 30 Meter Night Color of Lead-Free Thermoplastic at SH 21 Site.**



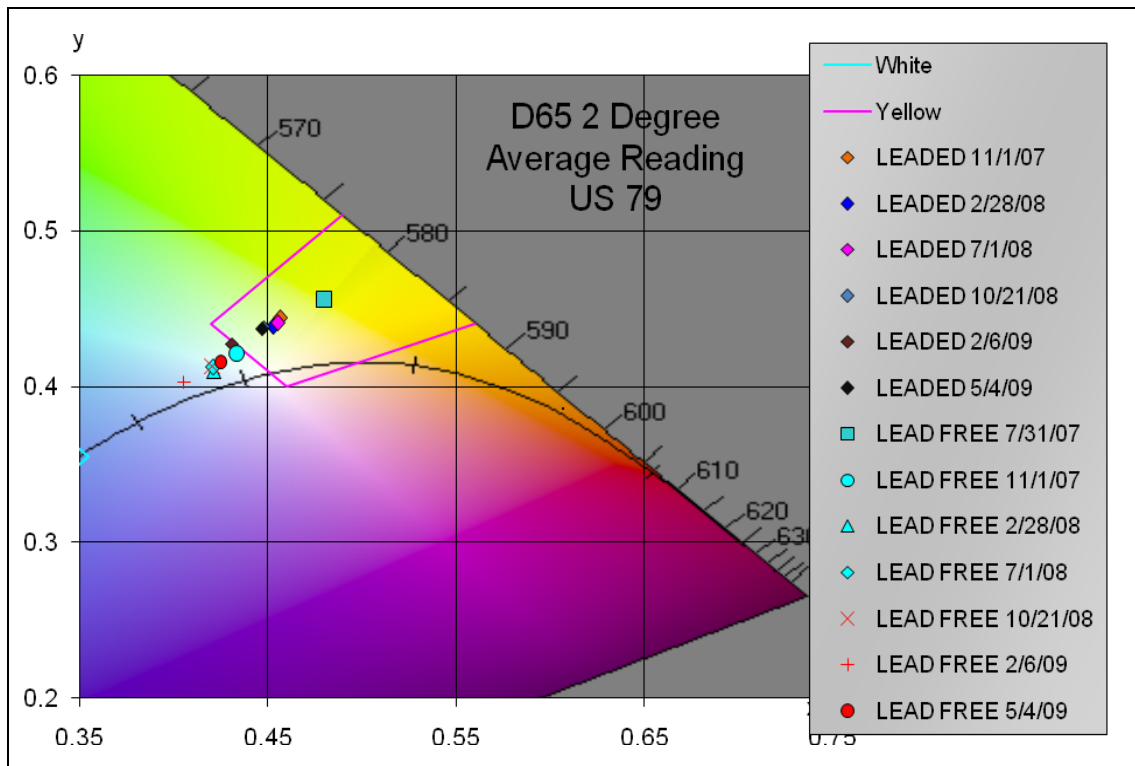
**Figure 29. Avg 30 Meter Night Color of Lead-Free Thermoplastic at SH 21 Extruded Site.**

**Color – 45/0**

The researchers also measured the color of the yellow thermoplastic marking materials containing beads and no beads using a range of illuminants and standard observers at a 45 degree illumination geometry and a 0 degree observation geometry. The color measurements on the beaded and non-beaded sections were pooled together after little difference was found between the two measurement sets. Figure 30 through Figure 36 display the average color values for each of the illuminants and standard observers for each measurement period at both locations. These points were plotted with the appropriate day or night color boxes. The TxDOT color box from DMS-8220 was used for the D65 10 degree standard observer measurements. Table 10 and Table F1 indicate the color box coordinates for the various measurements.

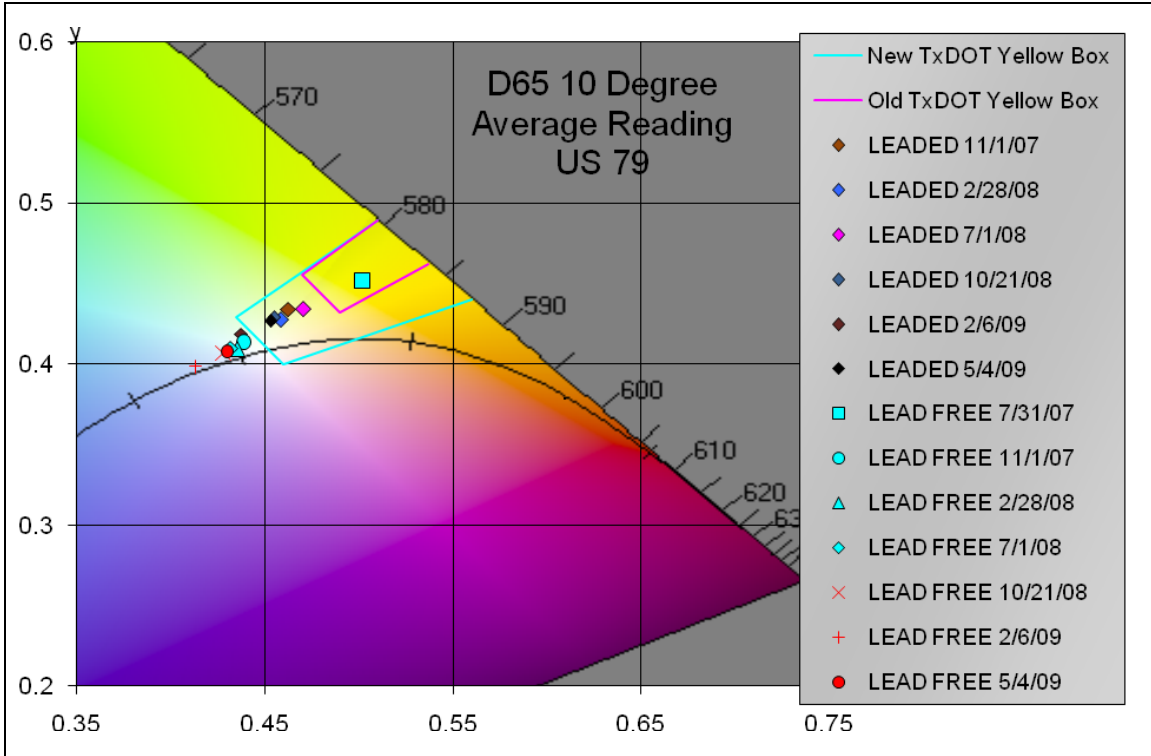
All of the initial measurements were within the TxDOT and FHWA color boxes for both standard observers. All of the Illuminant A 2 degree standard observer average readings at both sites 1 and 2 for each data collection period were within the FHWA and NCHRP nighttime color boxes. Looking at the daytime color measurements using Illuminant D65, some average

measurements have fallen outside of the new TxDOT color box requirements. The D65 10° measurements of both the leaded and lead-free material at both sites fall outside of the new TxDOT color box. The leaded material was outside of the box but much closer to the box than the lead-free material was at the US 79 site. At the SH 21 site the D65 10° measurements are right at the border of the color box. The D65 2° measurements of the leaded material all fall within the FHWA color box except for one reading at the US 79 site. The majority of the lead-free material color readings at the US 79 site are outside the D65 2° color box, whereas the measurements at the SH 21 sites are within the color box. The SH 21 D65 2° color readings all fall within the FHWA color box for both leaded and lead-free materials but are less saturated in color than the initial readings. The D65 2° readings of the leaded and lead-free material at the SH 21 site do not show much of a difference between each other, compared to the large difference at the US 79 site.

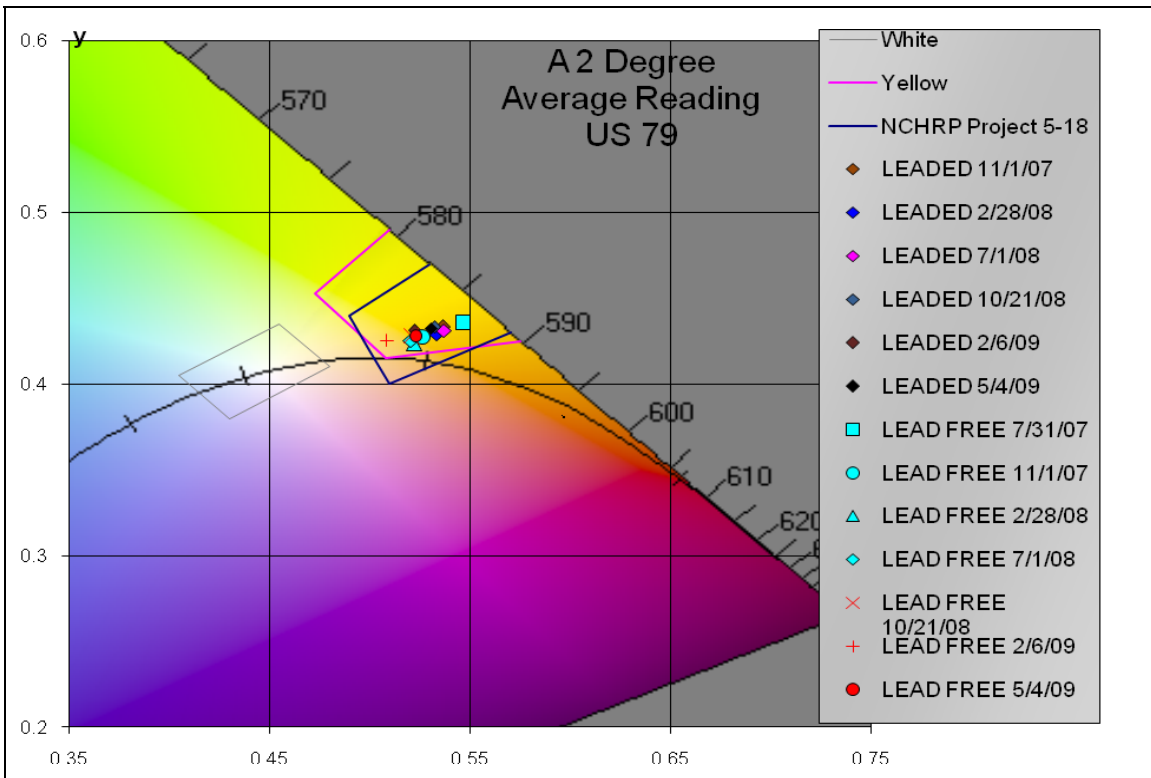


**Figure 30. Avg Daytime Color with 2 Degree Standard Observer at US 79 Site.**





**Figure 31. Avg Daytime Color with 10 Degree Standard Observer at US 79 Site.**



**Figure 32. Avg Nighttime Color with 2 Degree Standard Observer at US 79 Site.**

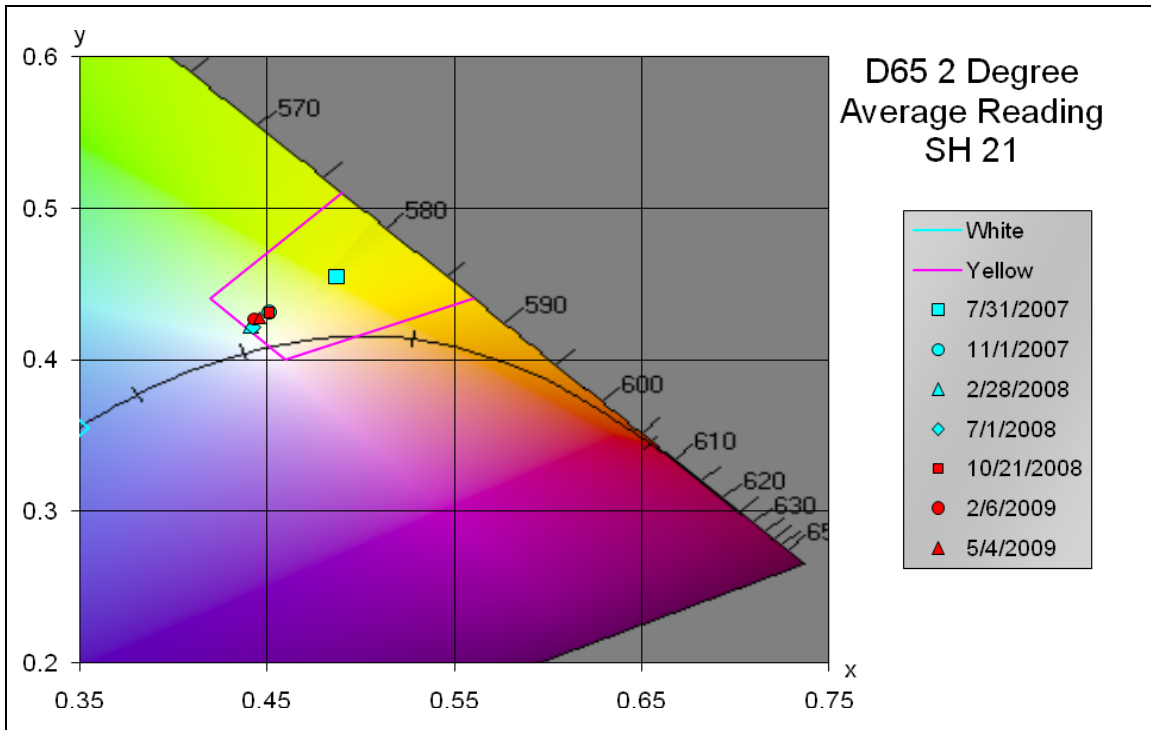


Figure 33. Avg Daytime Color with 2 Degree Standard Observer at SH 21 Site.

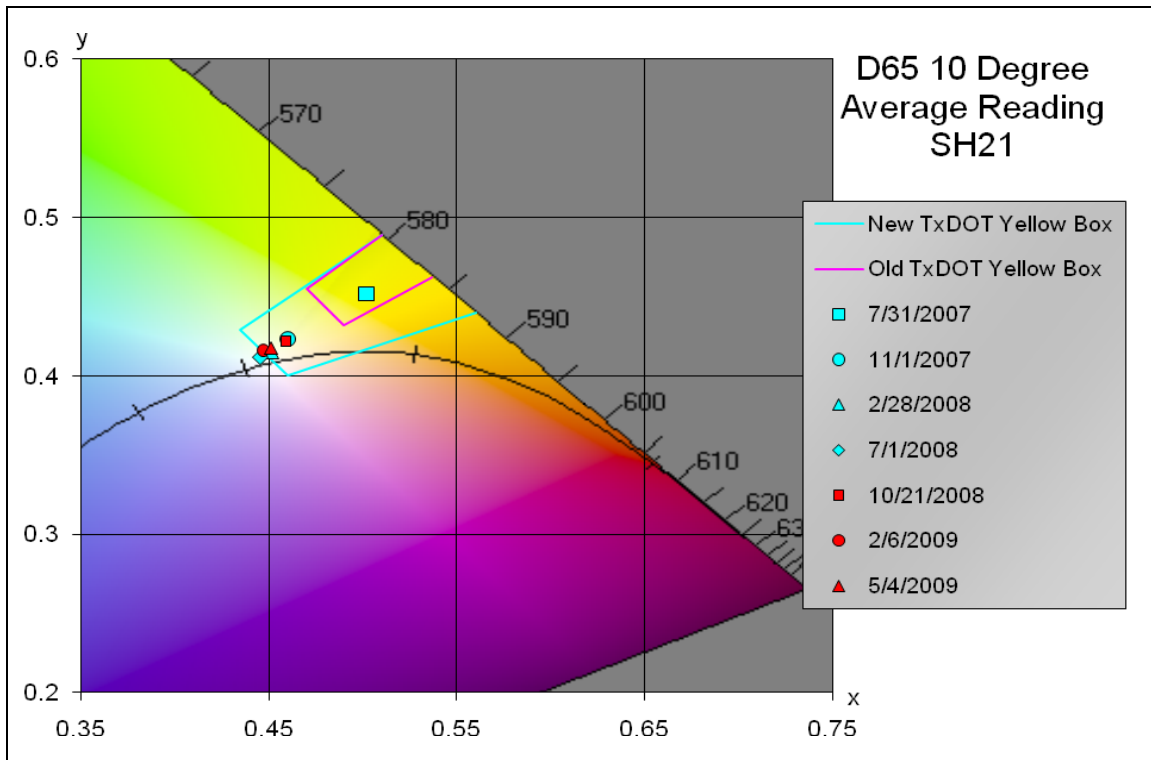


Figure 34. Avg Daytime Color with 10 Degree Standard Observer at SH 21 Site.

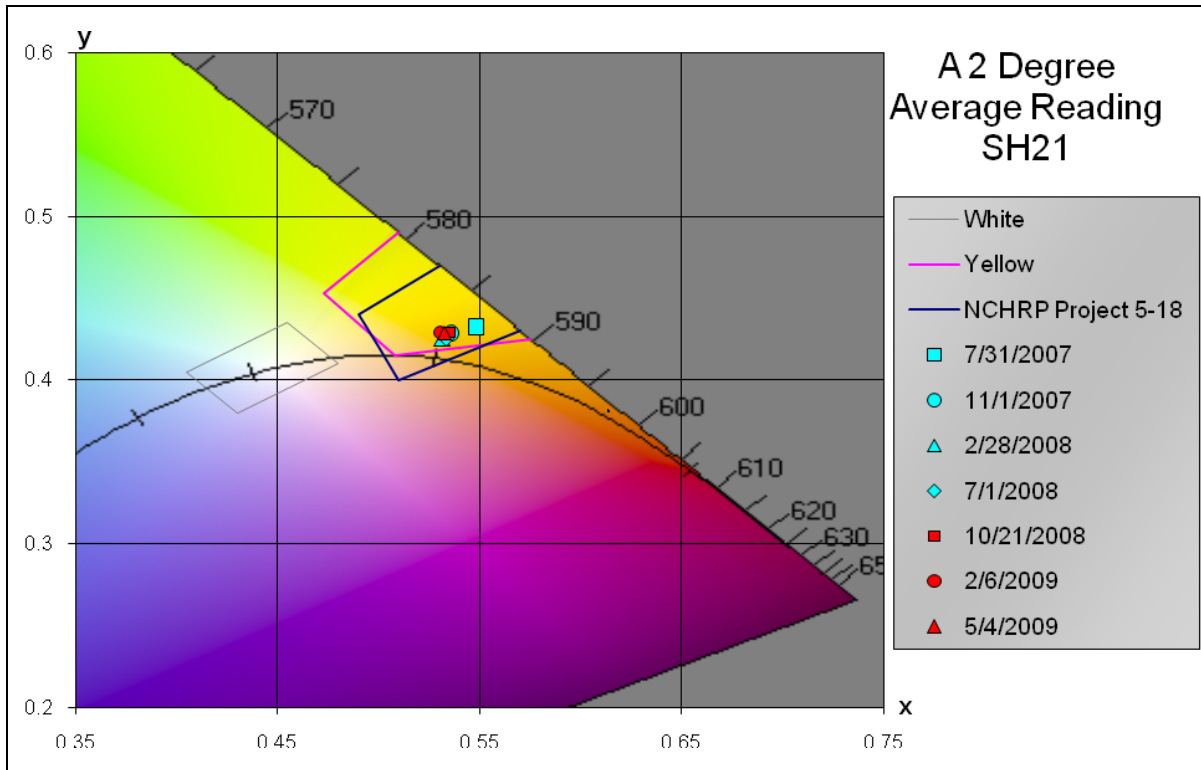


Figure 35. Avg Nighttime Color with 2 Degree Standard Observer at SH 21 Site.

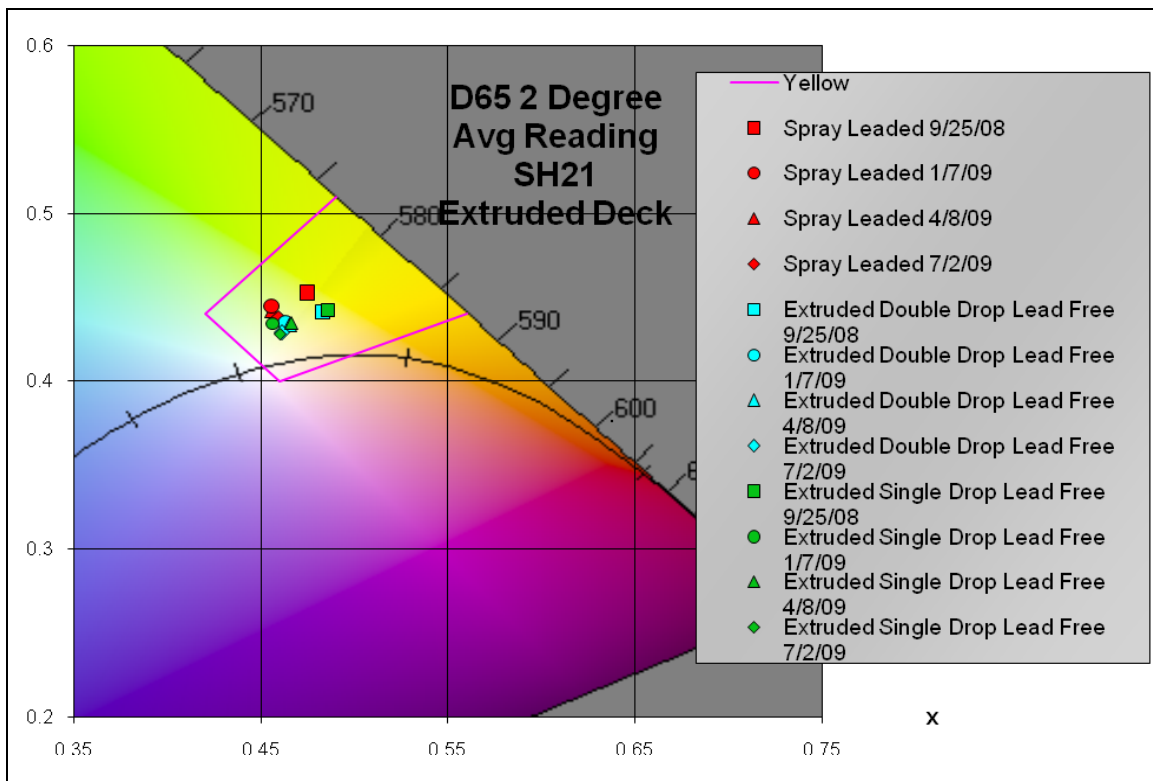


Figure 36. Avg Daytime Color with 2 Degree Standard Observer at SH 21 Extruded Site.

Subjective visual inspection of color during the data collection indicated a reduction in yellow quality of the markings. This daytime visual inspection would seem to match the D65 color data that was collected on the markings as the color data showed that the markings were moving away from yellow and toward white during daytime conditions. Appendix F Figure F1 shows images taken while conducting data collection at the US 79 site. From the pictures the color change and fading of the marking is noticeable. It should be noted that some of the color change is due to the accumulation of dirt while some of the color change is also due to the aging of the marking and its pigments. The lead-free marking visually appears to be slightly less saturated in yellow appearance than the leaded marking, which is supported with the D65 color data (Figure 30).

## **FINDINGS**

Based on the results of the almost two-year study presented above, the researchers offer the following findings regarding retroreflectivity and color of the lead-free thermoplastic pavement marking materials. Further evaluation will be conducted to assess the long-term (greater than 2 years) implications of using lead-free yellow thermoplastic material.

- Retroreflectivity:
  - ♦ The initial retroreflectivity of both the leaded and the lead-free thermoplastic applications are above the minimum level specified by TxDOT at sites 1 and 2. At site 3 the leaded and lead-free thermoplastic with Type II beads was slightly below the minimum initial retroreflectivity level, but the lead-free material with a double drop of Type II and IV beads exceeded the minimum level. The quality of the marking installation and the beads used seems to be a more significant factor in initial marking retroreflectivity than whether the marking has lead in it or not. The lead-free thermoplastic appears to be able to provide initial retroreflectivity levels similar to that of leaded material.
  - ♦ The retroreflectivity of the lead-free thermoplastic over the study period thus far indicates that the material behaves similar to that of leaded material based on the results of the comparison on US 79 and SH 21. The two-year retroreflectivity at the US 79 site for both the leaded and lead-free material was similar but at or below what may be considered a minimum level. This low

level of retroreflectivity is likely due to the high number of turning movements over the test area. The two-year retroreflectivity at the SH 21 site is still acceptable. The two-year retroreflectivity of the lead-free material appears to compare acceptably to the leaded material. The one-year old extruded lead-free thermoplastic appears to be performing as well if not better than the adjacent section of leaded thermoplastic.

- ♦ Retroreflectivity values can vary significantly from one location to another. A few of the factors that can cause variation in measured retroreflectivity include: marking pigment; difference in pavement surface smoothness; type, density, and embedment of the beads; marking thickness; and the accumulation of dirt on the marking. Differences in retroreflectivity between the leaded and lead-free marking samples may be due to factors other than the pigment.
- 30 Meter Nighttime Color
  - ♦ All of the average measurements from each data collection period on both the leaded and lead-free markings are within the FHWA color box. At sites 1 and 2 all the measurements were also within the NCHRP color box. The third site resulted in measurements that were right on the edge of the NCHRP color box.
  - ♦ The initial 30 meter nighttime color of the lead-free thermoplastic marking material appears to be acceptable. It appears from all three sites that as the markings age (both the leaded and the lead-free) they are trending toward the white area of the color box. The leaded marking at sites 1 and 3 were both more saturated in color initially and over time than were the lead-free markings. The 30 meter nighttime color of the lead-free thermoplastic marking material appears to compare acceptably to the leaded material.
- 45/0 Color
  - ♦ The standard color measurements using Illuminant D65 and Illuminant A of the leaded and lead-free material were initially found to be within the FHWA and TxDOT color boxes for yellow markings. The initial 45/0 color of the lead-free marking material appears to be acceptable.
  - ♦ The 45/0 Illuminant D65 color of the lead-free thermoplastic over the two-year study period indicates that the material has trended toward white more rapidly

than the leaded material at the US 79 site. The one-year study period at the SH 21 extruded deck has resulted in similar D65 color changes between the leaded and lead-free materials. The 2 degree standard observer measurements on the leaded material remained within the FHWA color box, whereas the lead-free material was outside of the box at the US 79 site. At the SH 21 site the 2 degree standard observer measurements remained within the FHWA box but were near the edge. The 10 degree standard observer measurements on the leaded material were not within the old TxDOT color box, but for the most part have remained within the new larger color box. The 10 degree standard observer measurements on the lead-free material were also outside of the old TxDOT box at the US 79 site and are also outside the new color box. At the SH 21 site the 10 degree standard observer measurements were outside the old TxDOT box but were within the new color box on the edge. The one year 45/0 color of the lead-free thermoplastic marking material appears to be closer to white than the leaded material.

- ♦ The 45/0 Illuminant A color of the lead-free thermoplastic over the two-year study period indicates that the lead-free material behaves similarly to that of the leaded material. All readings remained within the color box, which is acceptable for the lead-free material.

## **SUMMARY**

Initial measurements of the lead-free yellow thermoplastic pavement marking material at the three test deck locations compared favorably to the leaded material placed at two of the sites. Both materials were able to meet retroreflectivity and color requirements, except for the retroreflectivity requirement at test deck 3. The nearly two-year long evaluation of the lead-free material at the original two decks indicates that the lead-free material is able to retain its retroreflectivity as expected, maintain nighttime color at 30 meters and 45/0 but is unable to remain within the 45/0 Illuminant D65 daytime color box. The leaded material was able to remain within the D65 color box and overall produced a more saturated yellow than the lead-free material. The one-year evaluation at the third test deck indicated that the extruded lead-free thermoplastic compared favorably with the leaded spray applied thermoplastic. The biggest

difference was that the addition of larger beads on the lead-free material provided better retroreflectivity and that the leaded material provided a more saturated yellow than the lead-free marking.

The lead-free material appears to perform in a manner that is consistent with the standard TxDOT leaded material with respect to retroreflectivity and 45/0 Illuminant A color readings. The lead-free material appears to differ in 45/0 Illuminant D65 daytime color readings from the leaded material, the difference is that the lead-free material color is closer to white than the leaded material (less saturated). The nighttime 30 meter color measurements also differ, as the leaded material provides a more saturated yellow than the lead-free material but to a lesser extent than the daytime color difference.





## **CHAPTER 6: ON-GOING RESEARCH ACTIVITIES**

### **SIGNS WITH LIGHT EMITTING DIODES**

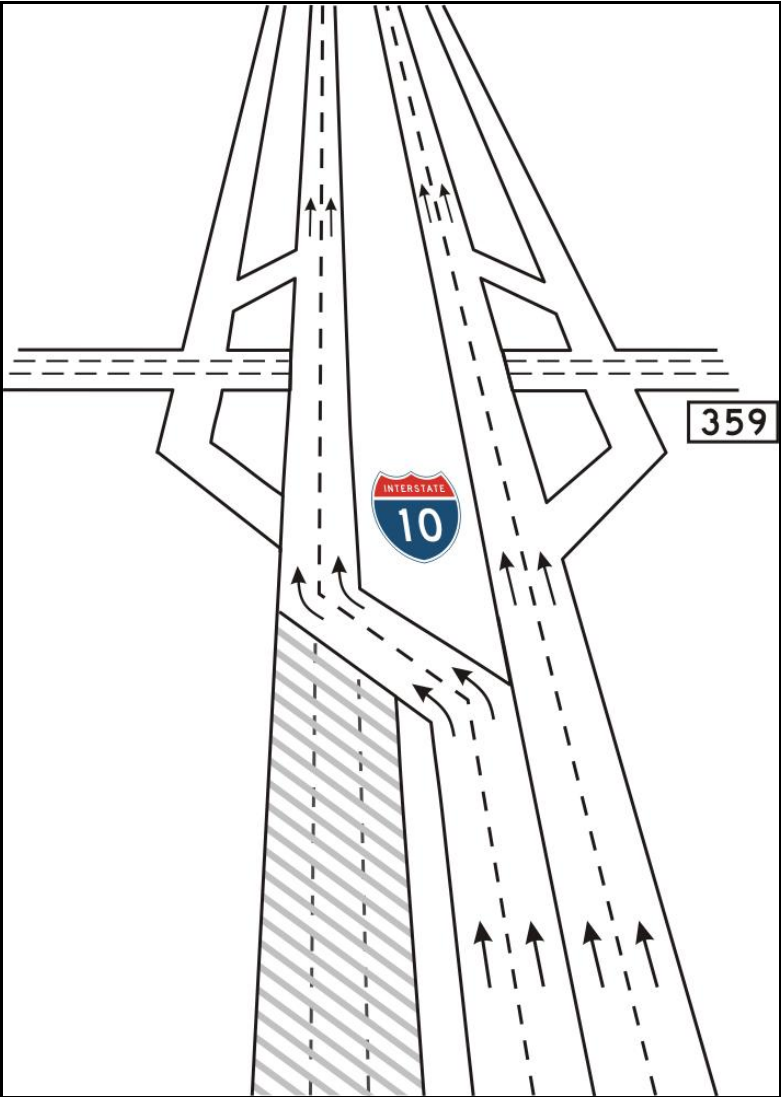
There are several emerging technologies that are being incorporated into traffic control devices. Light emitting diodes (LEDs) are one of these emerging technologies. While they are commonly used in traffic signals, their application to static signing and raised pavement markers is still evolving. Currently the National and the Texas MUTCDs contain no specific application guidance on signs with LEDs. Therefore, this activity was initially established to identify different applications of LEDs in traffic signs.

It was discovered that there are many different uses of LEDs in traffic signs. The information was presented to the project panel and as a result, the researchers will obtain examples of as many different signs as possible. A daytime and nighttime LED sign demonstration was conducted at the Texas A&M University Riverside campus in March 2010. The goal of the demonstration was to evaluate potential applications and concerns of the signs. At the time of publication of this report, the results of the LED sign demonstration were not available. Depending on the outcome, additional research may be needed before the devices can be employed in the field, or field evaluations might be scheduled to study the signs' effectiveness. One current study underway is looking at the effectiveness of LED-based curve warning signs that are activated depending on the difference between the approach speed and curve advisory speed (18).

### **HURRICANE EVACUATION ROUTING**

Initially, this effort was based on developing short video clips of hurricane evacuation routes for coastal cities. The idea was to provide these clips to news channels and post them on the web. However, preliminary investigations identified a number of challenges that ultimately led this research task in a different direction. The research activities ultimately resulted in a focused effort with the Houston District to assist integrating hurricane evacuation routing into TranStar's GIS-based website. Ultimately, the researchers developed diagrams of features such as contraflow transitions that were added to the GIS-based map as clickable icons. Figure 37

provides an example. This work will continue the following year with a focus on the Corpus Christi District.



**Figure 37. Diagram of I-10 Contraflow Transition.**

## REFERENCES

1. Rose, E.R., H.G. Hawkins, Jr., A.J. Holick, and R.P. Bligh. Evaluation of Traffic Control Devices: First-Year Activities. FHWA/TX-05/0-4701-1, Texas Transportation Institute, The Texas A&M University System, College Station, Texas, October 2004.
2. Hawkins Jr., H.G., R. Garg, P.J. Carlson, and A.J. Holick. Evaluation of Traffic Control Devices: Second-Year Activities. FHWA/TX-06/0-4701-2, Texas Transportation Institute, The Texas A&M University System, College Station, Texas, October 2005.
3. Hawkins Jr., H.G., M.A. Sneed, and C.L. Williams. Evaluation of Traffic Control Devices: Third-Year Activities. FHWA/TX-07/0-4701-3, Texas Transportation Institute, The Texas A&M University System, College Station, Texas, October 2006.
4. Hawkins Jr., H.G., C.L. Williams, and S. Sunkari. Evaluation of Traffic Control Devices: Fourth-Year Activities. FHWA/TX-08/0-4701-4, Texas Transportation Institute, The Texas A&M University System, College Station, Texas, October 2007.
5. Hawkins Jr., H.G., A.M. Pike, and M. Azimi. Evaluation of Traffic Control Devices: Fifth-Year Activities. FHWA/TX-09/0-4701-5, Texas Transportation Institute, The Texas A&M University System, College Station, Texas, October 2008.
6. Part VI of the Manual on Uniform Traffic Control Devices, *Standards and Guides for Traffic Controls for Street and Highway Construction, Maintenance, Utility and Incident Management Operations*, 2003 Edition, Revision 1, July 2004.
7. H.E. Ross, Jr., D.L. Sickling, R.A. Zimmer and J.D. Michie, *Recommended Procedures for the Safety Performance Evaluation of Highway Features*, National Cooperative Highway Research Program Report 350, Transportation Research Board, National Research Council, Washington, D.C., 1993.
8. Mak, K. K., Bligh, R. P., and Menges, W. L., (1995). *Evaluation of Work Zone Barricades and Temporary Sign Supports*, TTI Research Report 5388-1F, Texas Transportation Institute, College Station, Texas.
9. Mak, K. K., Bligh, R. P., and Menges, W. L., (1997). *Evaluation of Work Zone Barricades*, TTI Research Report 3910-S, Texas Transportation Institute, College Station, Texas.
10. Bligh, R. P. and Menges, W. L., (2004). *NCHRP Report 350 Test 3-71 of Allied Tube & Conduit Dual-Leg Perforated Square Steel Tube Temporary Sign Support*, TTI Research Report 400001-ATC1, Texas Transportation Institute, College Station, Texas.
11. Federal Highway Administration Memorandum from the Director, Office of Engineering, entitled: "ACTION: Identifying Acceptable Highway Safety Features," dated July 25, 1997.
12. *DMS-8220, Hot Applied Thermoplastic*. Texas Department of Transportation, Austin, Texas, August 2004.
13. *DMS-8220, Hot Applied Thermoplastic*. Texas Department of Transportation, Austin, Texas, September 2007.
14. *DMS-8220, Hot Applied Thermoplastic*. Texas Department of Transportation, Austin, Texas, May 2009.

15. Schnell, T., F. Aktan, C. Miller. Color Effectiveness of Yellow Pavement Marking Materials. NCHRP Web-Only Document 125, NCHRP Project 5-18, Transportation Research Board, Washington, D.C. Submitted December 2007.
16. *Special Specification 8251, Reflectorized Pavement Markings with Retroreflective Requirements*. Texas Department of Transportation, Austin, Texas, April 2009.
17. Traffic Control Devices on Federal-Aid and Other Streets and Highways; Color Specifications for Retroreflective Traffic Signs and Pavement Marking Materials. *Federal Register*, Vol 67, No. 147, Docket FHWA-99-6190, U.S. Government Printing Office, Washington, D.C., July 31, 2002, pages 49569-49575.
18. Evaluation of Speed Activated Displays on Curves, Institute for Transportation, Iowa State University, <http://www.intrans.iastate.edu/research/detail.cfm?project1D+1246486313>

## **APPENDIX A: CRASH TEST AND DATA ANALYSIS PROCEDURES**

The crash test and data analysis procedures were in accordance with guidelines presented in *NCHRP Report 350*. Brief descriptions of these procedures are presented as follows.

### **ELECTRONIC INSTRUMENTATION AND DATA PROCESSING**

The test vehicle was instrumented with three solid-state angular rate transducers to measure roll, pitch, and yaw rates; a triaxial accelerometer near the vehicle center of gravity (c.g.) to measure longitudinal, lateral, and vertical acceleration levels; and a backup biaxial accelerometer in the rear of the vehicle to measure longitudinal and lateral acceleration levels. These accelerometers were ENDEVCO<sup>®</sup> Model 2262CA, piezoresistive accelerometers with a  $\pm 100$  g range.

The accelerometers are strain gage types with a linear millivolt output proportional to acceleration. Angular rate transducers are solid state, gas flow units designed for high-“g” service. Signal conditioners and amplifiers in the test vehicle increase the low-level signals to a  $\pm 2.5$  volt maximum level. The signal conditioners also provide the capability of a resistive calibration (R-cal) or shunt calibration for the accelerometers and a precision voltage calibration for the rate transducers. The electronic signals from the accelerometers and rate transducers are transmitted to a base station by means of a 15-channel, constant bandwidth, Inter-Range Instrumentation Group (I.R.I.G.), FM/FM telemetry link for recording and for display. Calibration signals from the test vehicle are recorded before the test and immediately afterwards. A crystal-controlled time reference signal is simultaneously recorded with the data. Wooden dowels actuate pressure-sensitive switches on the bumper of the impacting vehicle prior to impact by wooden dowels to indicate the elapsed time over a known distance to provide a measurement of impact velocity. The initial contact also produces an “event” mark on the data record to establish the instant of contact with the installation.

The multiplex of data channels, transmitted on one radio frequency, is received and demultiplexed onto a TEAC<sup>®</sup> instrumentation data recorder. After the test, the data are played back from the TEAC<sup>®</sup> recorder and digitized. A proprietary software program (WinDigit)

converts the analog data from each transducer into engineering units using the R-cal and pre-zero values at 10,000 samples per second per channel. WinDigit also provides Society of Automotive Engineers (SAE) J211 class 180 phaseless digital filtering and vehicle impact velocity.

All accelerometers are calibrated annually according to the SAE J211 4.6.1 by means of an ENDEVCO® 2901, precision primary vibration standard. This device and its support instruments are returned to the factory annually for a National Institute of Standards Technology (NIST) traceable calibration. The subsystems of each data channel are also evaluated annually, using instruments with current NIST traceability, and the results are factored into the accuracy of the total data channel, per SAE J211. Calibrations and evaluations are made any time data are suspect.

The Test Risk Assessment Program (TRAP) uses the data from WinDigit to compute occupant/compartment impact velocities, time of occupant/compartment impact after vehicle impact, and the highest 10-millisecond (ms) average ridedown acceleration. WinDigit calculates change in vehicle velocity at the end of a given impulse period. In addition, WinDigit computes maximum average accelerations over 50-ms intervals in each of the three directions. For reporting purposes, the data from the vehicle-mounted accelerometers are filtered with a 60-Hz digital filter, and acceleration versus time curves for the longitudinal, lateral, and vertical directions are plotted using TRAP.

TRAP uses the data from the yaw, pitch, and roll rate transducers to compute angular displacement in degrees at 0.0001-s intervals and then plots yaw, pitch, and roll versus time. These displacements are in reference to the vehicle-fixed coordinate system with the initial position and orientation of the vehicle-fixed coordinate systems being initial impact.

## **ANTHROPOMORPHIC DUMMY INSTRUMENTATION**

An Alderson Research Laboratories Hybrid II, 50<sup>th</sup> percentile male anthropomorphic dummy, restrained with lap and shoulder belts, was placed in the driver's position of the 820C vehicle. The dummy was uninstrumented.

## **PHOTOGRAPHIC INSTRUMENTATION AND DATA PROCESSING**

Photographic coverage of the test included two high-speed cameras: one placed behind the installation at a 45-degree angle and one placed to have a field-of-view perpendicular to and

aligned with the installation/vehicle path. A flash bulb activated by pressure-sensitive tape switches was positioned on the impacting vehicle to indicate the instant of contact with the installation and was visible from each camera. The films from these high-speed cameras were analyzed on a computer-linked Motion Analyzer to observe phenomena occurring during the collision and to obtain time-event, displacement, and angular data. Videos and still cameras were used to record and document conditions of the test vehicle and installation before and after the test.

### **TEST VEHICLE PROPULSION AND GUIDANCE**

The test vehicle was towed into the test installation using a steel cable guidance and reverse tow system. A steel cable for guiding the test vehicle was tensioned along the path, anchored at each end, and threaded through an attachment to the front wheel of the test vehicle. An additional steel cable was connected to the test vehicle, passed around a pulley near the impact point, through a pulley on the tow vehicle, and then anchored to the ground such that the tow vehicle moved away from the test site. A 2-to-1 speed ratio between the test and tow vehicle existed with this system. Just prior to impact with the installation, the test vehicle was released to be free-wheeling and unrestrained. The vehicle remained free-wheeling, i.e., no steering or braking inputs, until the vehicle cleared the immediate area of the test site, at which time the vehicle's brakes were activated to bring it to a safe and controlled stop.





## APPENDIX B: TEST VEHICLE PROPERTIES AND INFORMATION

Vehicle Inventory Number:       791      

Date: 2009-05-28 Test No.: 463849-1 VIN No.: 2S2AB21H516604785

Year: 2001 Make: Suzuki Model: Swift

Tire Inflation Pressure: 32 psi Odometer: 123896 Tire Size: P155/80R13

Describe any damage to the vehicle prior to test: \_\_\_\_\_

⊕ Denotes accelerometer location.

NOTES: \_\_\_\_\_

Engine Type: 4 cylinder

Engine CID: 1.3 liter

Transmission Type:

       Auto

  x   Manual

Optional Equipment: \_\_\_\_\_

Dummy Data:

Type: 50<sup>th</sup> percentile male

Mass: 165 lb

Seat Position: Driver side

### Geometry ( inches )

A	<u>62.60</u>	E	<u>23.62</u>	J	<u>25.59</u>	N	<u>54.52</u>	R	<u>15.35</u>
B	<u>31.10</u>	F	<u>147.83</u>	K	<u>20.28</u>	O	<u>53.54</u>	S	<u>22.05</u>
C	<u>93.11</u>	G	<u>34.86</u>	L	<u>4.72</u>	P	<u>22.44</u>	T	<u>39.76</u>
D	<u>55.91</u>	H	<u>      </u>	M	<u>15.75</u>	Q	<u>14.37</u>	U	<u>96.06</u>

ALLOWABLE RANGE: B = 750 ±100 mm ; C = 2300 ±100 mm; F = 3700 ±200 mm; G = 800 ±150 mm; H = 550 ±50 mm; N = 1350 ±100 mm

ALLOWABLE RANGE: B = 29.5 ±4 inches ; C = 90.6 ±4 inches; F = 145.7 ±8 inches; G = 31.5 ±5.9 inches; H = 21.6 ±2 inches; N = 53.1 ±4 inches

### Mass

( lb )	<u>Curb</u>	<u>Test Inertial</u>	<u>Gross Static</u>
M <sub>1</sub>	<u>1169</u>	<u>1164</u>	<u>1232</u>
M <sub>2</sub>	<u>659</u>	<u>697</u>	<u>794</u>
M <sub>Total</sub>	<u>1828</u>	<u>1861</u>	<u>2026</u>

Allowable Range      Allowable Range

Mass Distribution

( lb ):                      LF: 602      RF: 562      LR: 328      RR: 368

**Figure B1. Vehicle Properties for Test 463849-1.**

**Table B1. Exterior Crush Measurements for Test 463849-1.**

**VEHICLE CRUSH MEASUREMENT SHEET<sup>1</sup>**

Complete When Applicable	
End Damage	Side Damage
Undeformed end width _____ Corner shift: A1 _____ A2 _____ End shift at frame (CDC) (check one) < 4 inches _____ ≥ 4 inches _____	Bowing: B1 _____ X1 _____ B2 _____ X2 _____ Bowing constant $\frac{X1 + X2}{2} = \underline{\hspace{2cm}}$

Note: Measure C<sub>1</sub> to C<sub>6</sub> from Driver to Passenger Side in Front or Rear Impacts – Rear to Front in Side Impacts.

Specific Impact Number	Plane* of C-Measurements	Direct Damage		Field L**	C <sub>1</sub>	C <sub>2</sub>	C <sub>3</sub>	C <sub>4</sub>	C <sub>5</sub>	C <sub>6</sub>	±D
		Width** (CDC)	Max*** Crush								
1	Frontal plane at bumper ht	19.68	7.87	39.37	2.00	3.54	5.12	6.30	3.54	2.00	0
	Measurements in inches										

<sup>1</sup>Table taken from National Accident Sampling System (NASS).

\*Identify the plane at which the C-measurements are taken (e.g., at bumper, above bumper, at sill, above sill, at beltline, etc.) or label adjustments (e.g., free space).

Free space value is defined as the distance between the baseline and the original body contour taken at the individual C locations. This may include the following: bumper lead, bumper taper, side protrusion, side taper, etc. Record the value for each C-measurement and maximum crush.

\*\*Measure and document on the vehicle diagram the beginning or end of the direct damage width and field L (e.g., side damage with respect to undamaged axle).

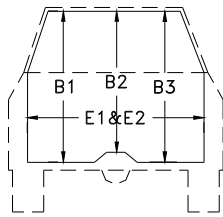
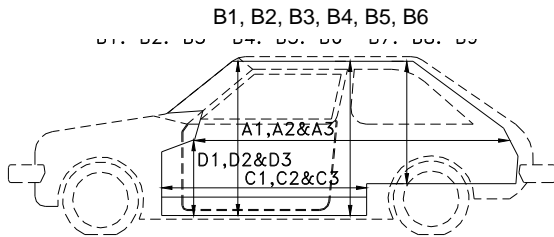
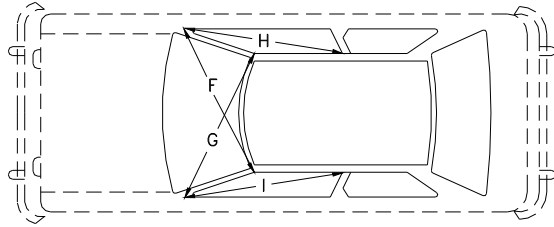
\*\*\*Measure and document on the vehicle diagram the location of the maximum crush.

Note: Use as many lines/columns as necessary to describe each damage profile.

**Table B2. Occupant Compartment Measurements for Test 463849-1.**

# Small Car

Occupant Compartment Deformation



	<b>BEFORE</b> (inches)	<b>AFTER</b> (inches)
A1	56.89	56.89
A2	78.74	78.74
A3	56.50	56.50
B1	37.32	37.32
B2	35.35	35.35
B3	37.80	37.80
B4	35.04	35.04
B5	35.24	35.24
B6	35.04	35.04
C1	24.33	24.33
C2	----	----
C3	26.18	26.18
D1	9.25	9.25
D2	4.17	4.17
D3	9.84	9.84
E1	47.87	47.87
E2	46.50	46.50
F	47.83	47.83
G	47.83	47.83
H	40.55	40.55
I	40.55	40.55
J*	47.24	47.24

\*Lateral area across the cab from driver's side kickpanel to passenger's side kickpanel.

Vehicle Inventory Number: 798

Date: 2009-07-28 Test No.: 463849-2 VIN No.: 2C1MR229176780632

Year: 1996 Make: Geo Model: Metro

Tire Inflation Pressure: 32 psi Odometer: 67953 Tire Size: P155/80R13

Describe any damage to the vehicle prior to test: \_\_\_\_\_

⊕ Denotes accelerometer location.

NOTES: \_\_\_\_\_  
 \_\_\_\_\_  
 \_\_\_\_\_

Engine Type: 4 cylinder  
 Engine CID: 1.3 liter  
 Transmission Type:

Auto  
 Manual

Optional Equipment:  
 \_\_\_\_\_  
 \_\_\_\_\_

Dummy Data:  
 Type: 50<sup>th</sup> percentile male  
 Mass: 165 lb  
 Seat Position: Driver side

**Geometry ( inches )**

A	<u>62.60</u>	E	<u>23.62</u>	J	<u>25.59</u>	N	<u>54.53</u>	R	<u>15.35</u>
B	<u>31.10</u>	F	<u>147.83</u>	K	<u>20.28</u>	O	<u>53.54</u>	S	<u>22.05</u>
C	<u>93.11</u>	G	<u>33.98</u>	L	<u>4.72</u>	P	<u>22.44</u>	T	<u>39.76</u>
D	<u>55.91</u>	H	_____	M	<u>15.75</u>	Q	<u>14.37</u>	U	<u>96.06</u>

ALLOWABLE RANGE: B = 750 ±100 mm ; C = 2300 ±100 mm; F = 3700 ±200 mm; G = 800 ±150 mm; H = 550 ±50 mm; N = 1350 ±100 mm

ALLOWABLE RANGE: B = 29.5 ±4 inches ; C = 90.6 ±4 inches; F = 145.7 ±8 inches; G = 31.5 ±5.9 inches; H = 21.6 ±2 inches; N = 53.1 ±4 inches

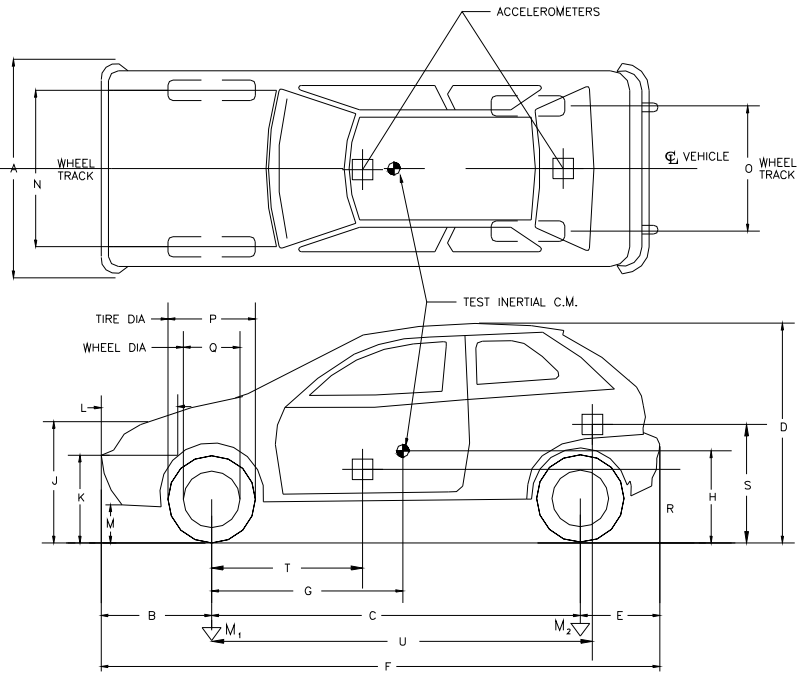
**Mass**

( lb )	<u>Curb</u>	<u>Test Inertial</u>	<u>Gross Static</u>
M <sub>1</sub>	<u>1208</u>	<u>1182</u>	<u>1268</u>
M <sub>2</sub>	<u>644</u>	<u>679</u>	<u>760</u>
M <sub>Total</sub>	<u>1852</u>	<u>1861</u>	<u>2028</u>

Allowable Range: 1146 ±55 lb      820 ±25 kg      1973 ±55 lb      895 ±25 kg

**Mass Distribution**

( lb ):      LF: 613      RF: 569      LR: 350      RR: 328



**Figure B2. Vehicle Properties for Test 463849-2.**

**Table B3. Exterior Crush Measurements for Test 463849-2.**

**VEHICLE CRUSH MEASUREMENT SHEET<sup>1</sup>**

Complete When Applicable	
End Damage	Side Damage
Undeformed end width _____  Corner shift: A1 _____ A2 _____  End shift at frame (CDC) (check one) < 4 inches _____ ≥ 4 inches _____	Bowing: B1 _____ X1 _____ B2 _____ X2 _____  Bowing constant $\frac{X1 + X2}{2} = \underline{\hspace{2cm}}$

Note: Measure C<sub>1</sub> to C<sub>6</sub> from driver to passenger side in front or rear impacts – rear to front in side impacts.

Specific Impact Number	Plane* of C-Measurements	Direct Damage		Field L**	C <sub>1</sub>	C <sub>2</sub>	C <sub>3</sub>	C <sub>4</sub>	C <sub>5</sub>	C <sub>6</sub>	±D
		Width** (CDC)	Max*** Crush								
1	Front bumper at bumper ht	2.0	9.1	35.4	0	4.0	8.0	8.0	4.0	0	0
	Measurements in inches										

<sup>1</sup>Table taken from National Accident Sampling System (NASS).

\*Identify the plane at which the C-measurements are taken (e.g., at bumper, above bumper, at sill, above sill, at beltline, etc.) or label adjustments (e.g., free space).

Free space value is defined as the distance between the baseline and the original body contour taken at the individual C locations. This may include the following: bumper lead, bumper taper, side protrusion, side taper, etc. Record the value for each C-measurement and maximum crush.

\*\*Measure and document on the vehicle diagram the beginning or end of the direct damage width and field L (e.g., side damage with respect to undamaged axle).

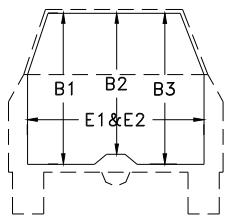
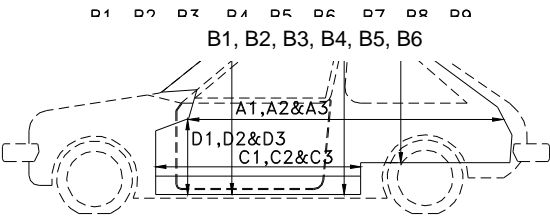
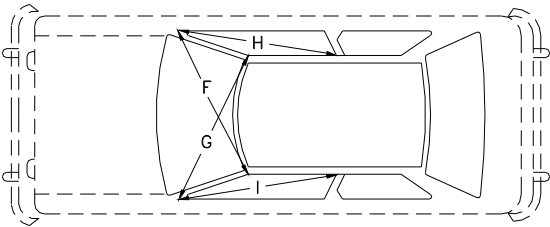
\*\*\*Measure and document on the vehicle diagram the location of the maximum crush.

Note: Use as many lines/columns as necessary to describe each damage profile.

**Table B4. Occupant Compartment Measurements for Test 463849-2.**

# Small Car

Occupant Compartment Deformation



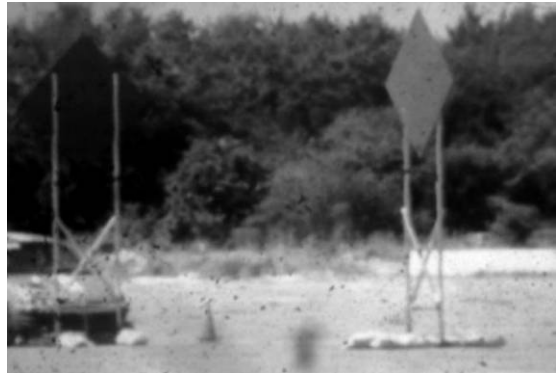
	<b>BEFORE</b> (inches)	<b>AFTER</b> (inches)
A1	<u>56.57</u>	<u>56.57</u>
A2	<u>79.13</u>	<u>79.13</u>
A3	<u>56.34</u>	<u>56.34</u>
B1	<u>37.80</u>	<u>37.80</u>
B2	<u>35.63</u>	<u>35.63</u>
B3	<u>37.95</u>	<u>37.95</u>
B4	<u>34.92</u>	<u>34.92</u>
B5	<u>35.24</u>	<u>35.24</u>
B6	<u>34.92</u>	<u>34.92</u>
C1	<u>24.41</u>	<u>24.41</u>
C2	<u>----</u>	<u>----</u>
C3	<u>24.41</u>	<u>24.41</u>
D1	<u>9.53</u>	<u>9.53</u>
D2	<u>3.58</u>	<u>3.58</u>
D3	<u>10.00</u>	<u>10.00</u>
E1	<u>47.83</u>	<u>47.83</u>
E2	<u>46.38</u>	<u>46.38</u>
F	<u>47.83</u>	<u>47.83</u>
G	<u>47.83</u>	<u>47.83</u>
H	<u>40.55</u>	<u>40.55</u>
I	<u>40.55</u>	<u>40.55</u>
J*	<u>47.24</u>	<u>47.24</u>

\*Lateral area across the cab from driver's side kickpanel to passenger's side kickpanel.

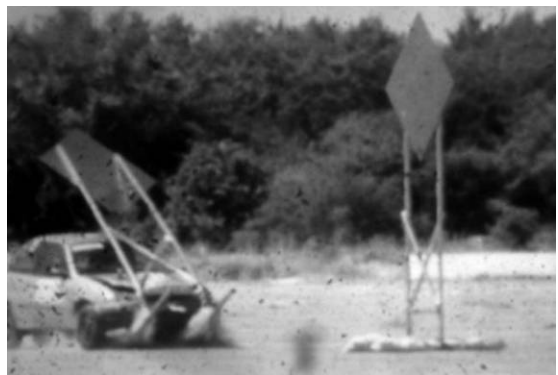
**APPENDIX C:  
SEQUENTIAL PHOTOGRAPHS**



0.000 s



0.100 s



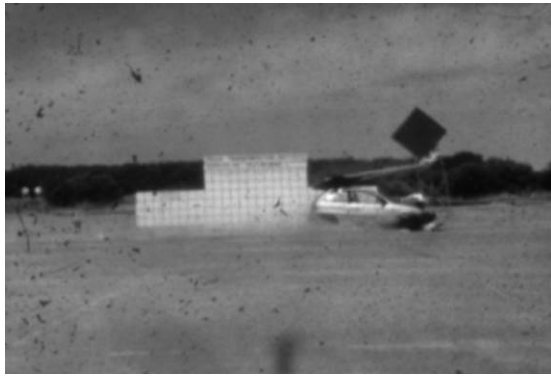
0.200 s



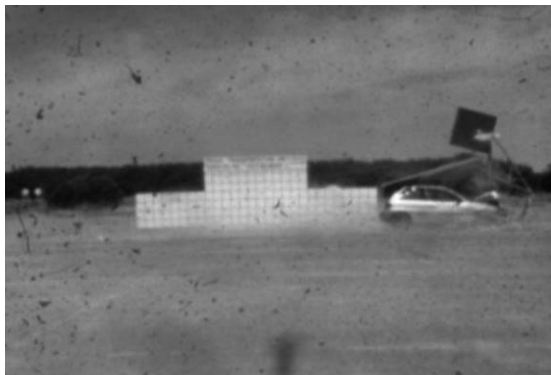
0.300 s



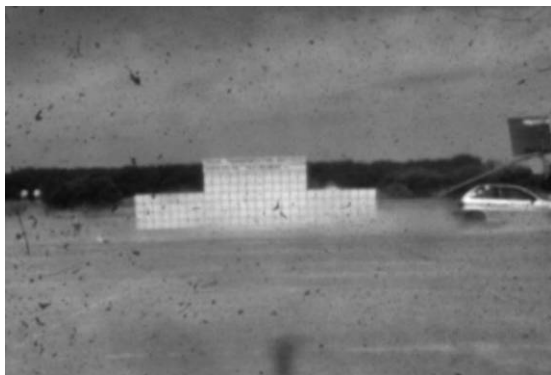
**Figure C1. Sequential Photographs for Test 463849-1 (Perpendicular and Oblique Views).**



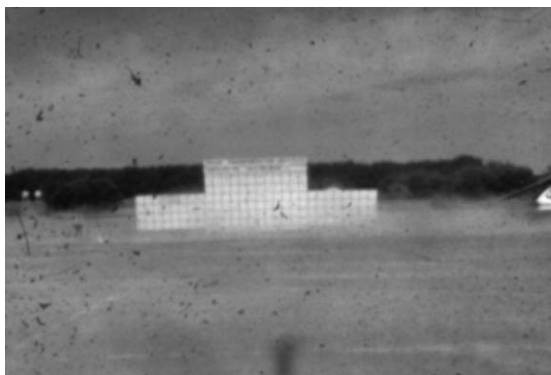
0.400s



0.500 s



0.600 s



0.700 s

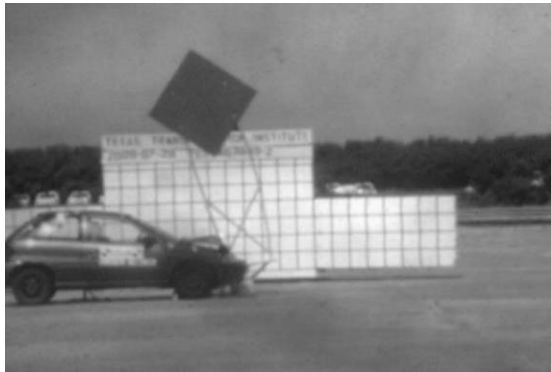


**Figure C1. Sequential Photographs for Test 463849-1 (Perpendicular and Oblique Views) (Continued).**

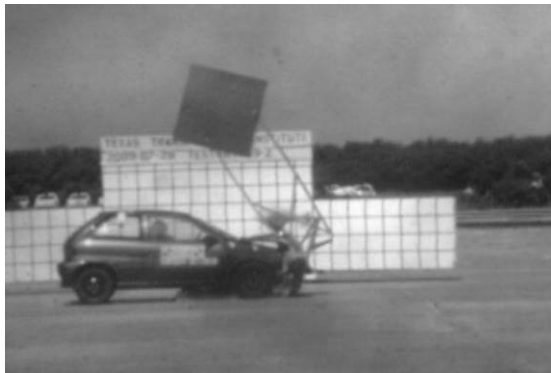




0.000 s



0.036 s



0.072 s



0.108 s



**Figure C2. Sequential Photographs for Test 463849-2 (Perpendicular and Oblique Views).**



0.144 s



0.180 s



0.216 s

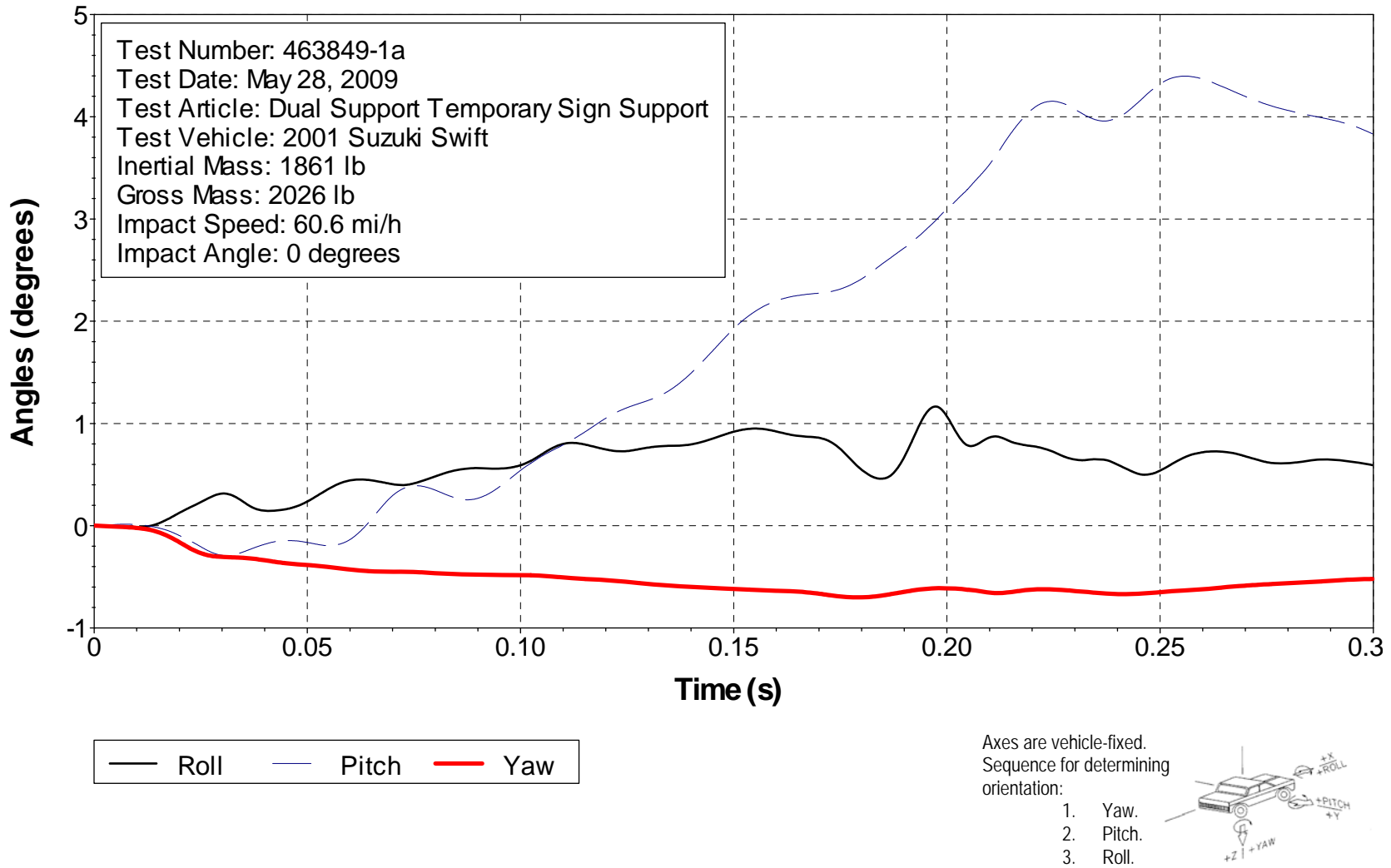


0.276 s



**Figure C2. Sequential Photographs for Test 463849-2 (Perpendicular and Oblique Views) (Continued).**

## Roll, Pitch, and Yaw Angles



**Figure D1. Vehicle Angular Displacements for Test 463849-1.**

# X Acceleration at CG

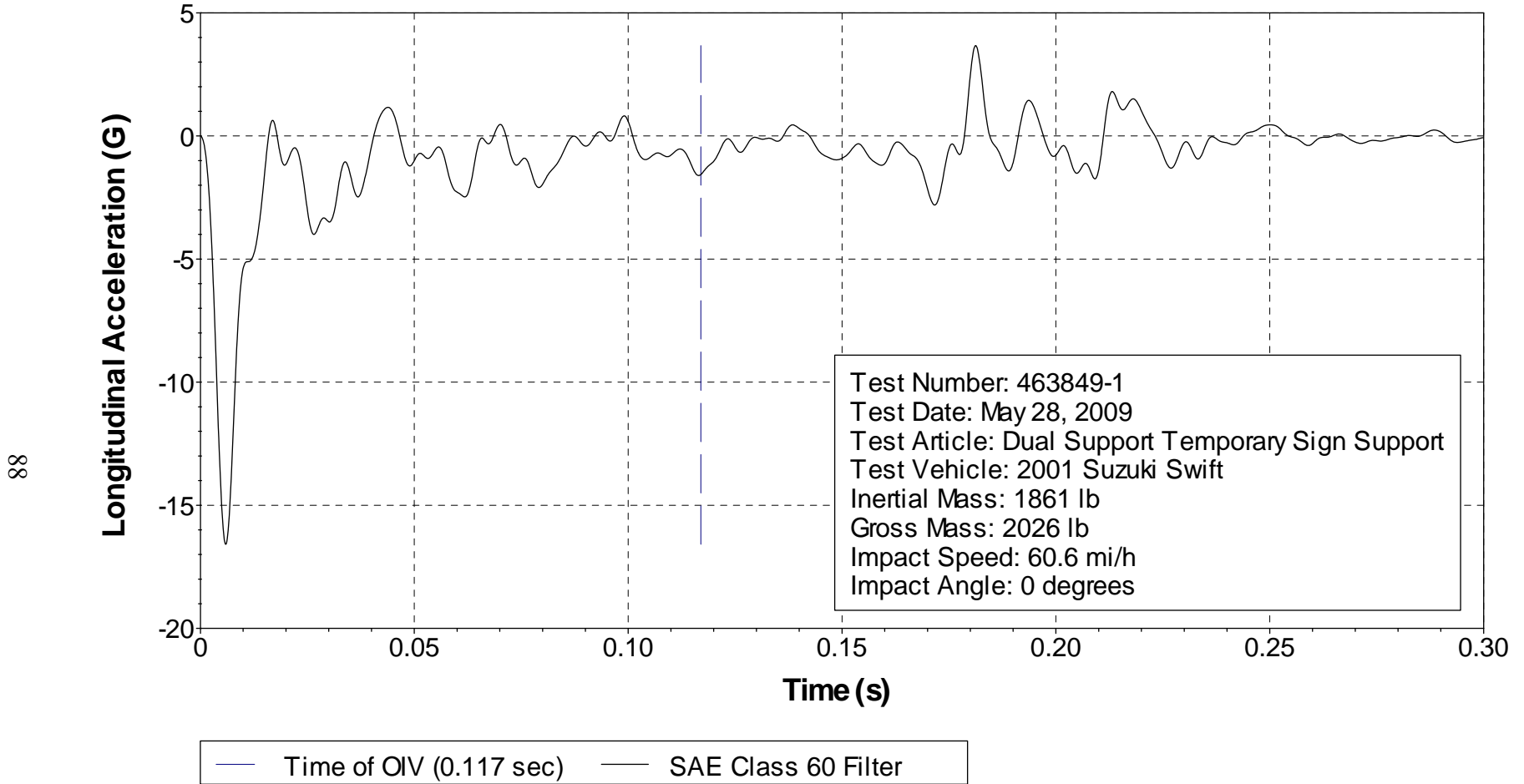


Figure D2. Vehicle Longitudinal Accelerometer Trace for Test 463849-1 (Accelerometer Located at Center of Gravity).

## Y Acceleration at CG

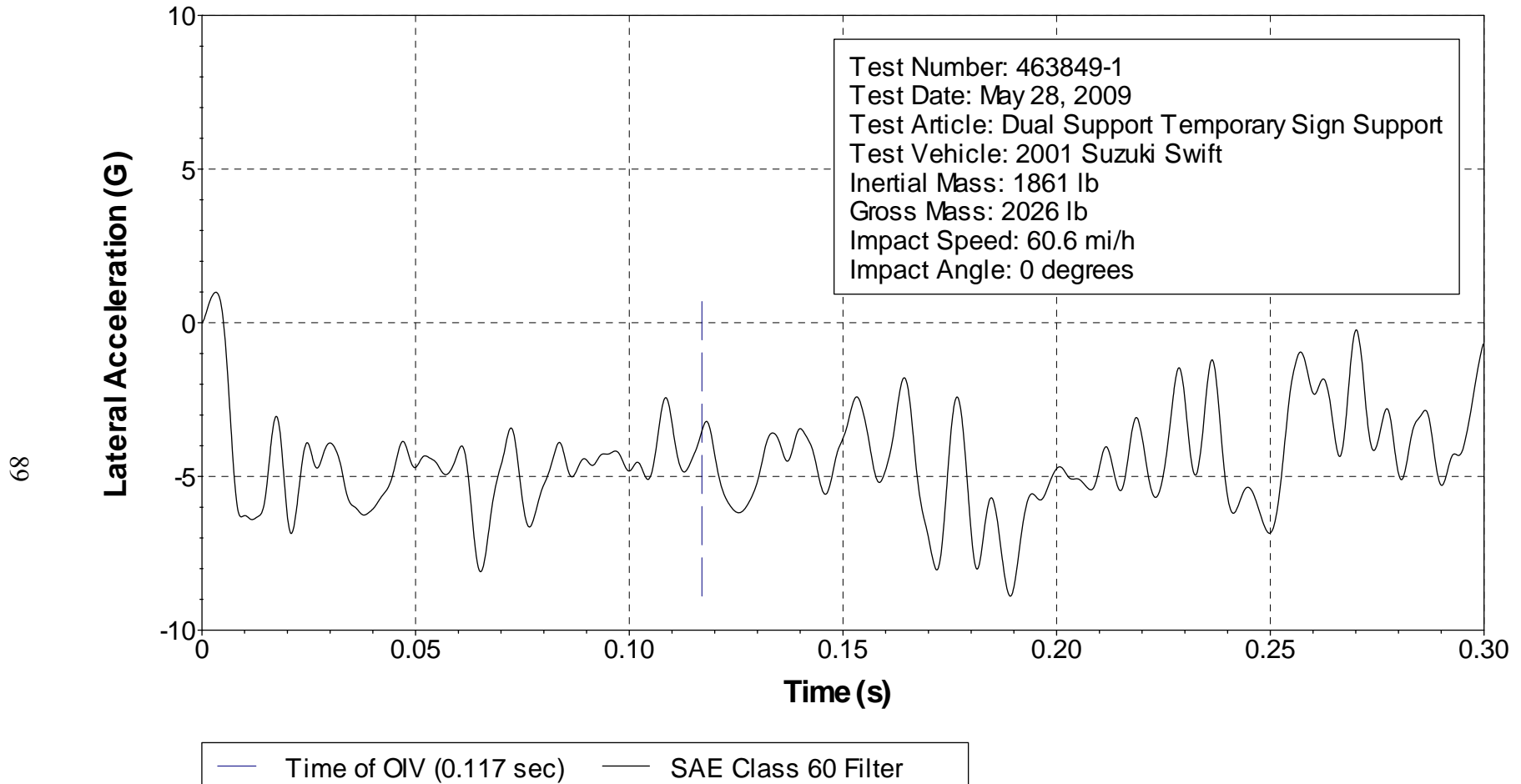


Figure D3. Vehicle Lateral Accelerometer Trace for Test 463849-1 (Accelerometer Located at Center of Gravity).

# Z Acceleration at CG

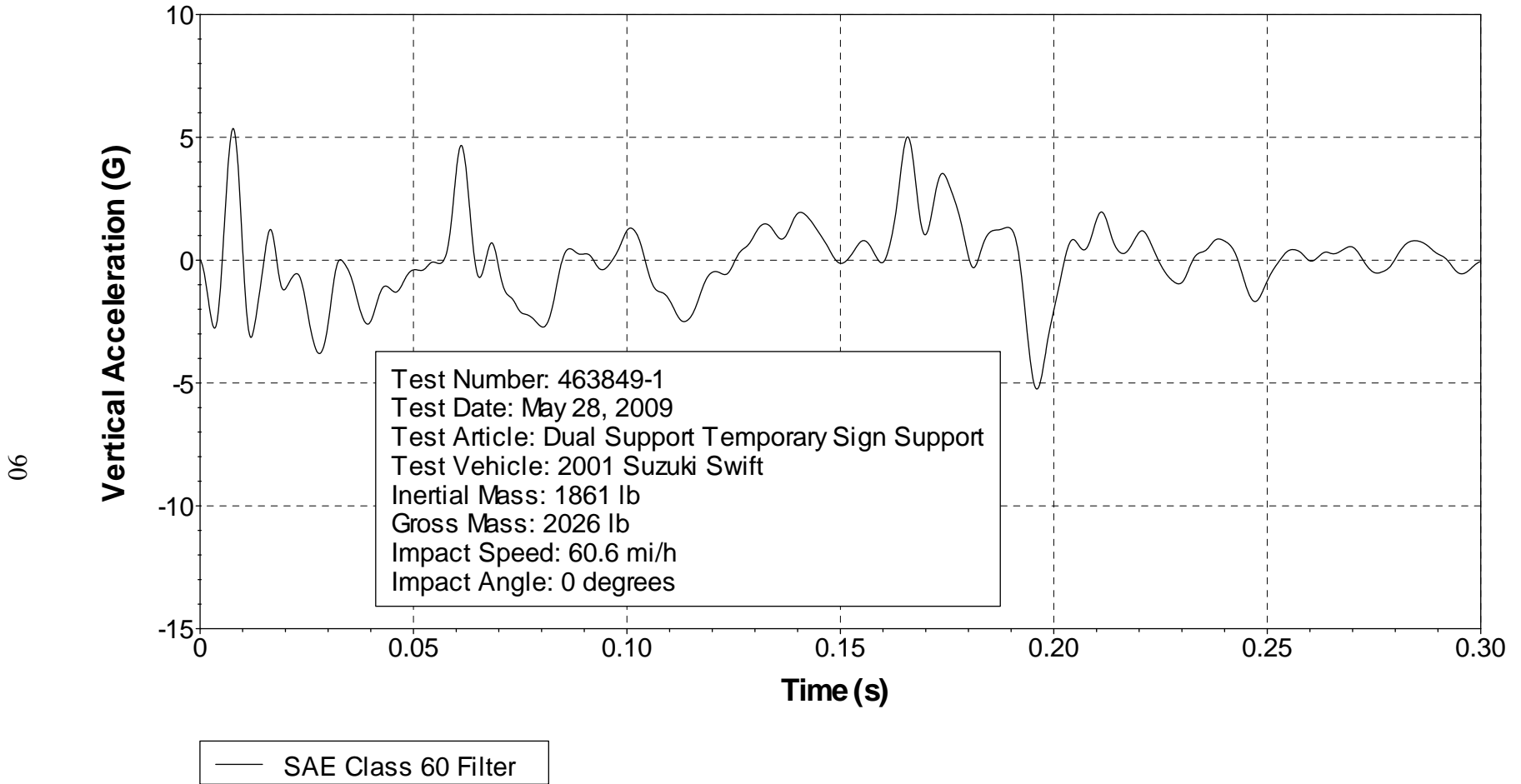


Figure D4. Vehicle Vertical Accelerometer Trace for Test 463849-1 (Accelerometer Located at Center of Gravity).

## *X Acceleration over Rear Axle*

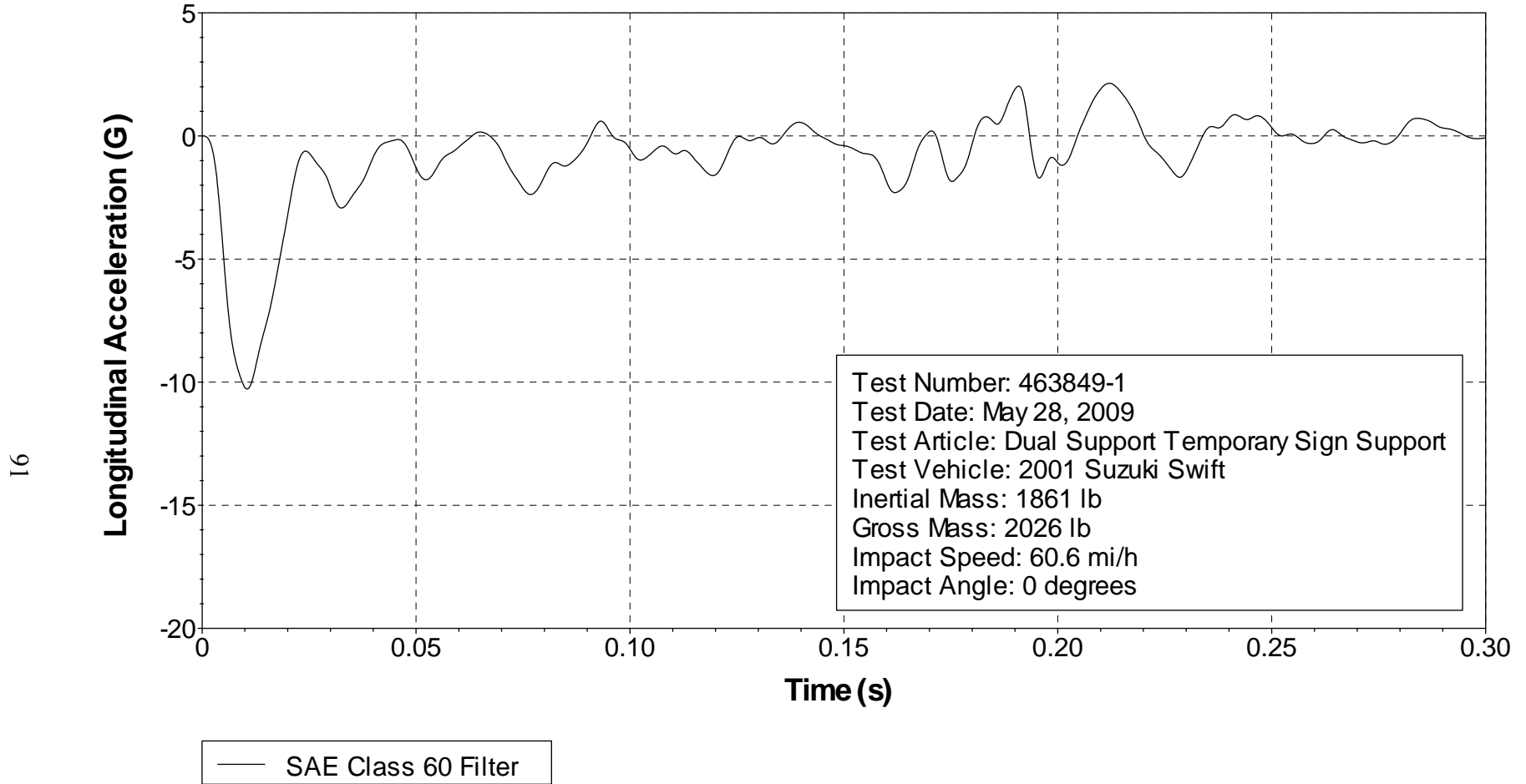


Figure D5. Vehicle Longitudinal Accelerometer Trace for Test 463849-1 (Accelerometer Located over Rear Axle).

## Y Acceleration over Rear Axle

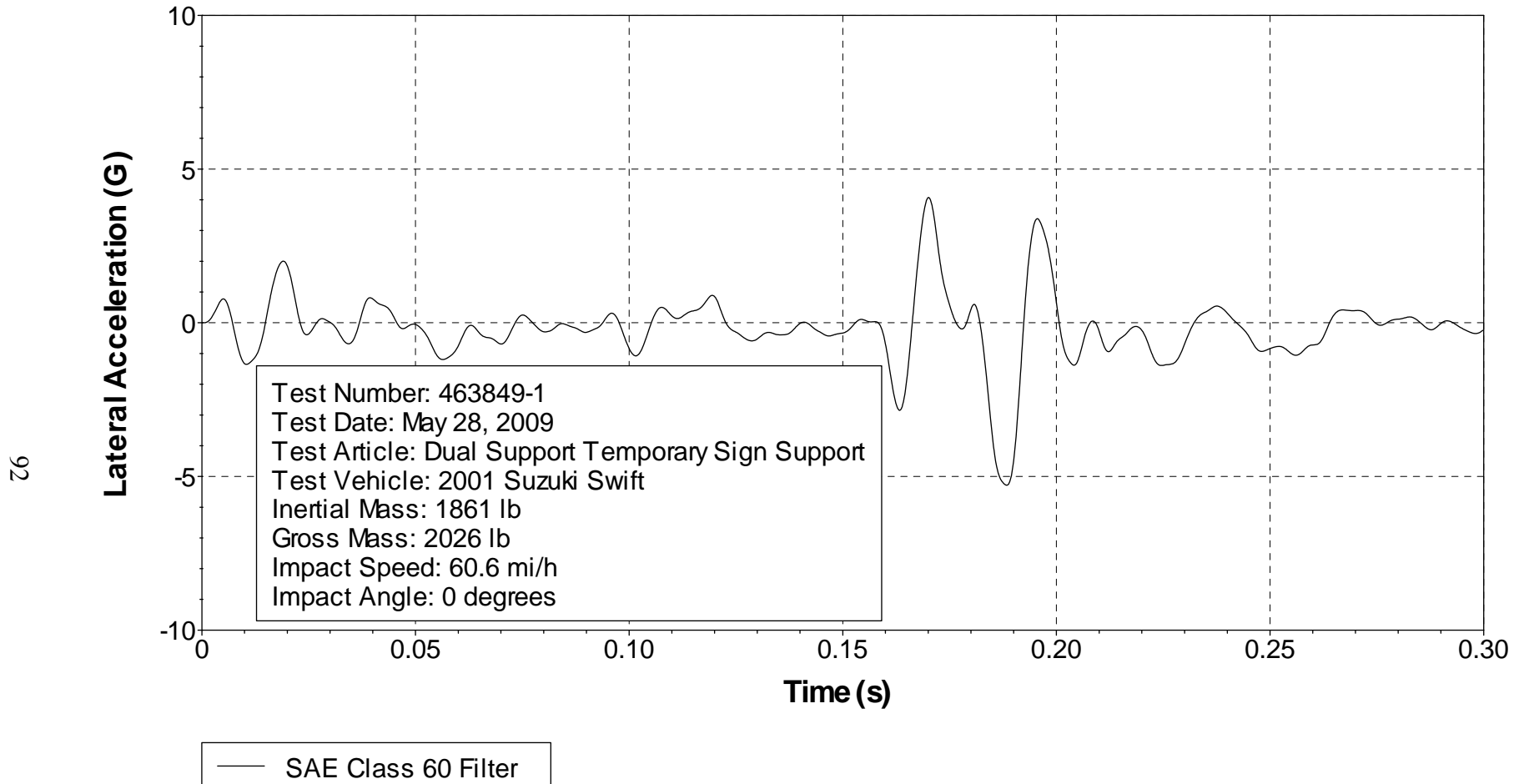
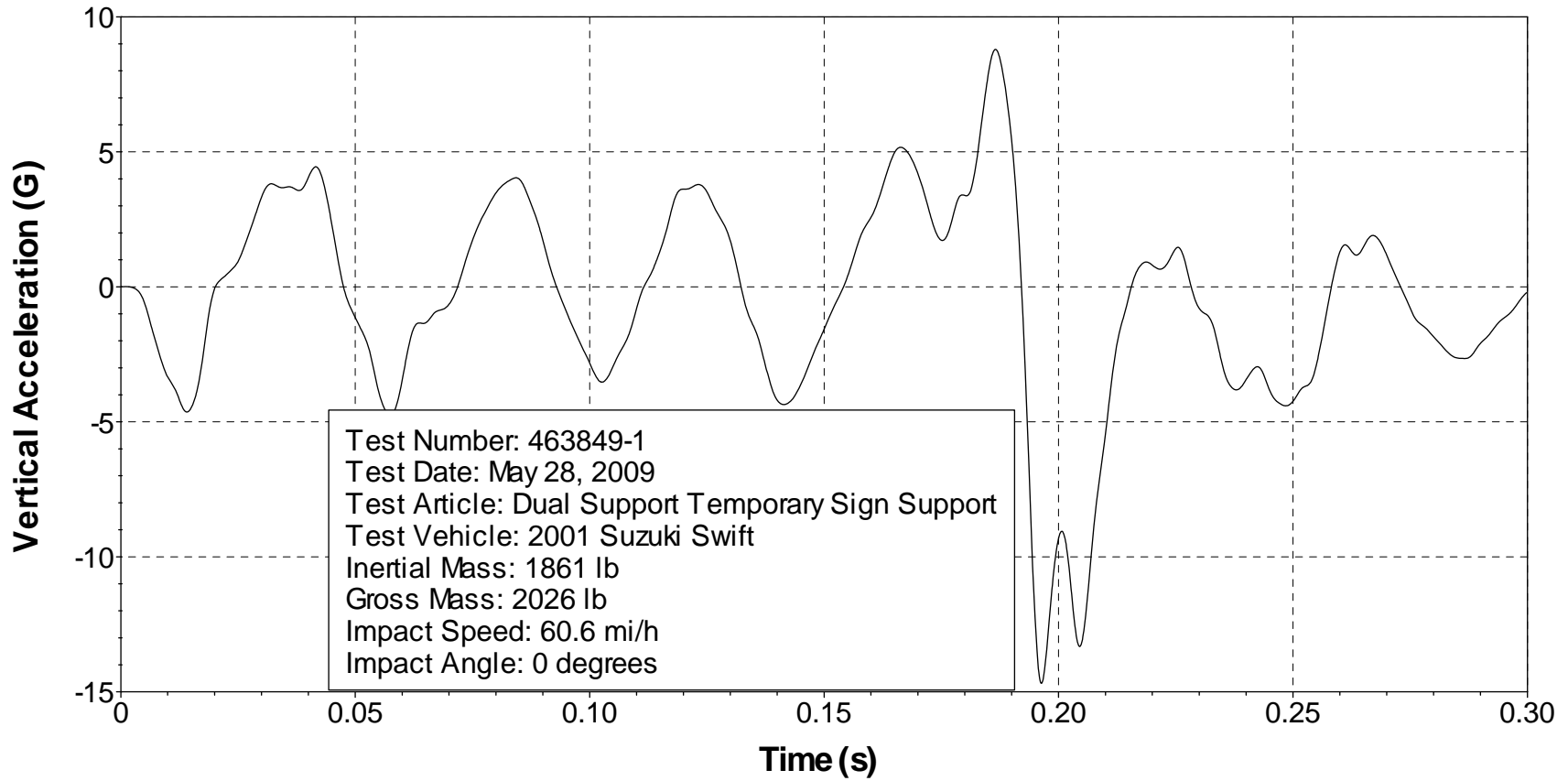


Figure D6. Vehicle Lateral Accelerometer Trace for Test 463849-1 (Accelerometer Located over Rear Axle).



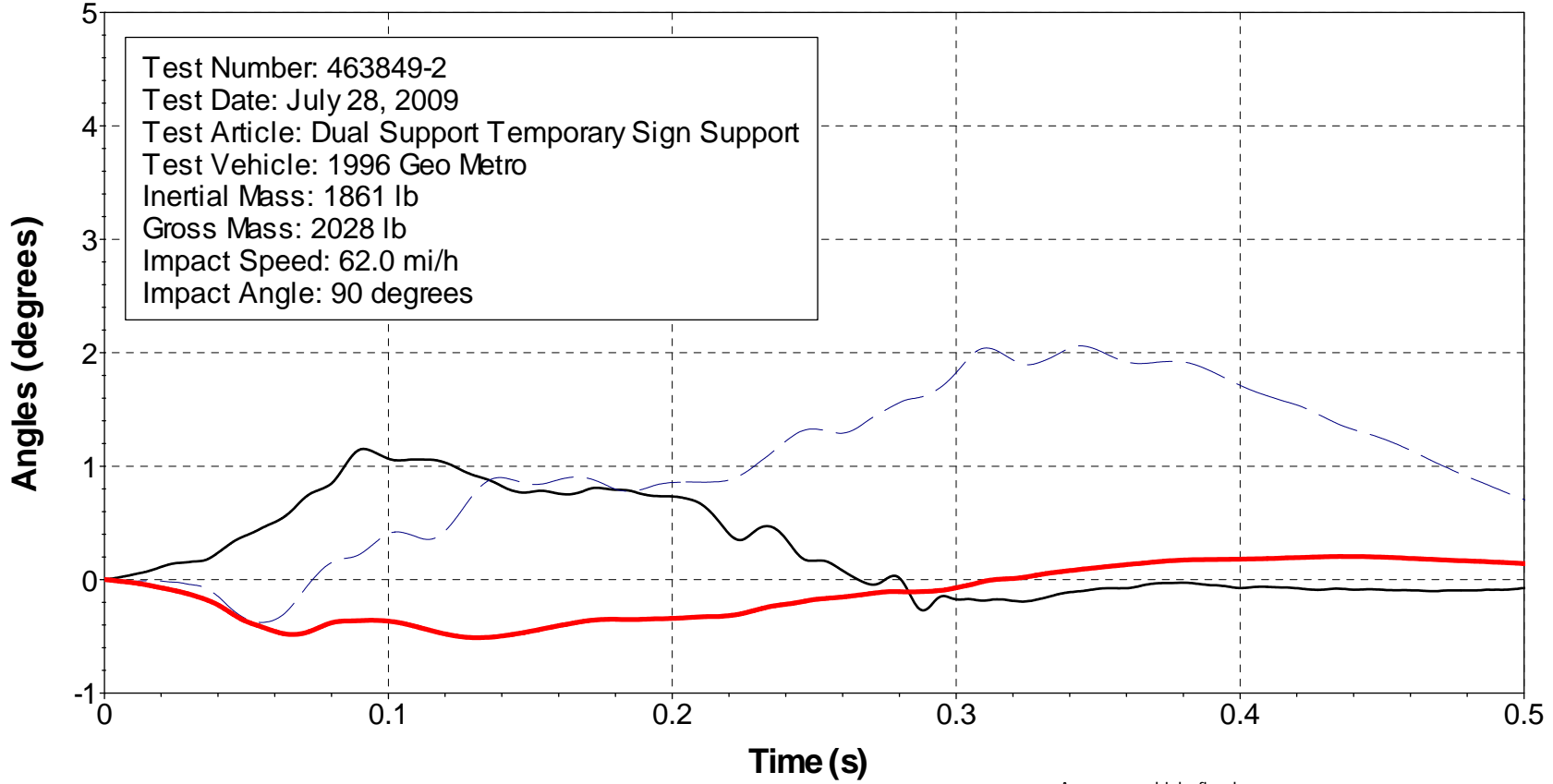
## Z Acceleration over Rear Axle



— SAE Class 60 Filter

Figure D7. Vehicle Vertical Accelerometer Trace for Test 463849-1 (Accelerometer Located over Rear Axle).

# Roll, Pitch, and Yaw Angles



94

— Roll    — Pitch    — Yaw

Axes are vehicle-fixed.  
 Sequence for determining orientation:

1. Yaw.
2. Pitch.
3. Roll.

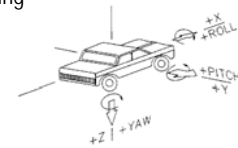


Figure D8. Vehicle Angular Displacements for Test 463849-2.

# X Acceleration at CG

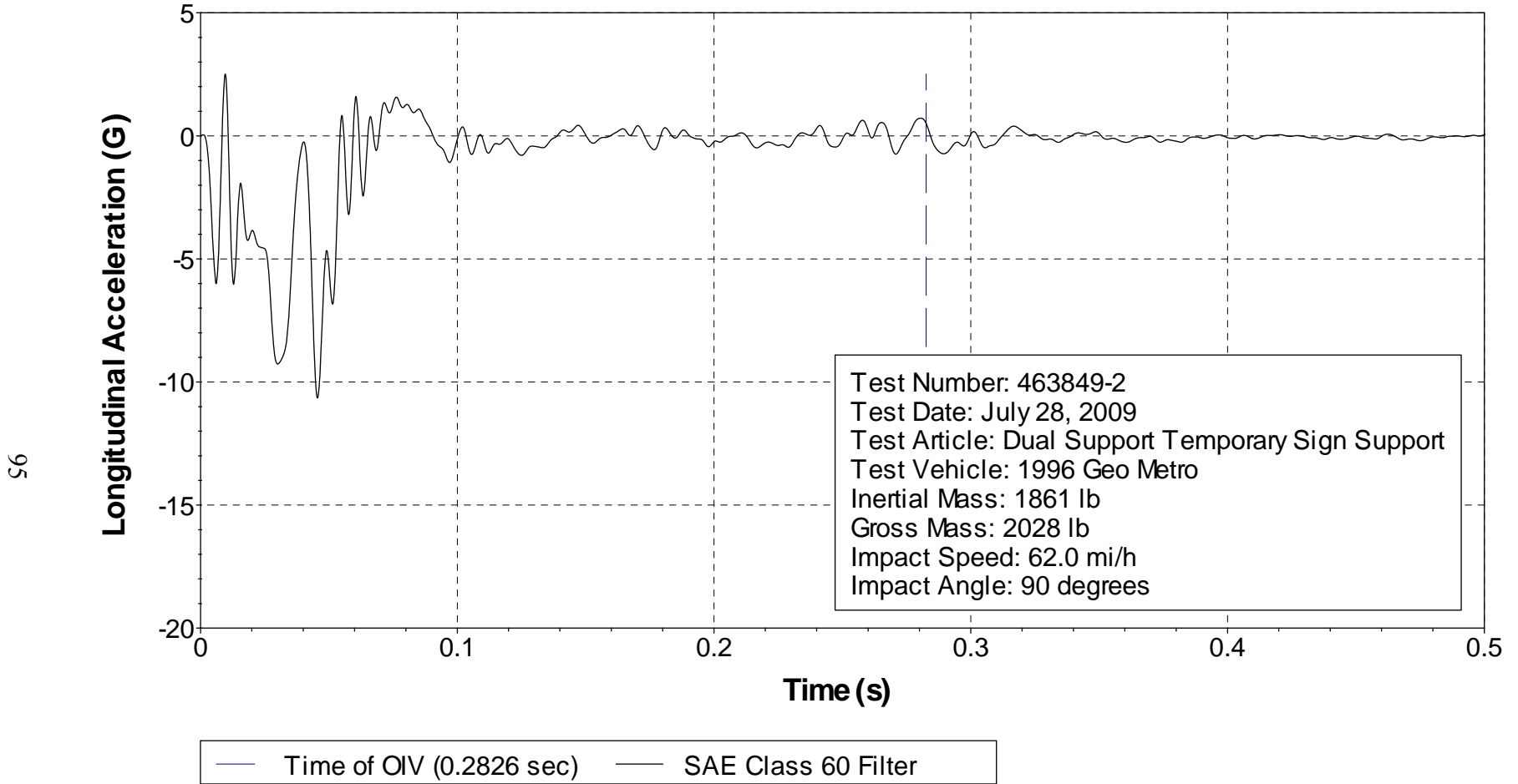


Figure D9. Vehicle Longitudinal Accelerometer Trace for Test 463849-2 (Accelerometer Located at Center of Gravity).

## Y Acceleration at CG

96

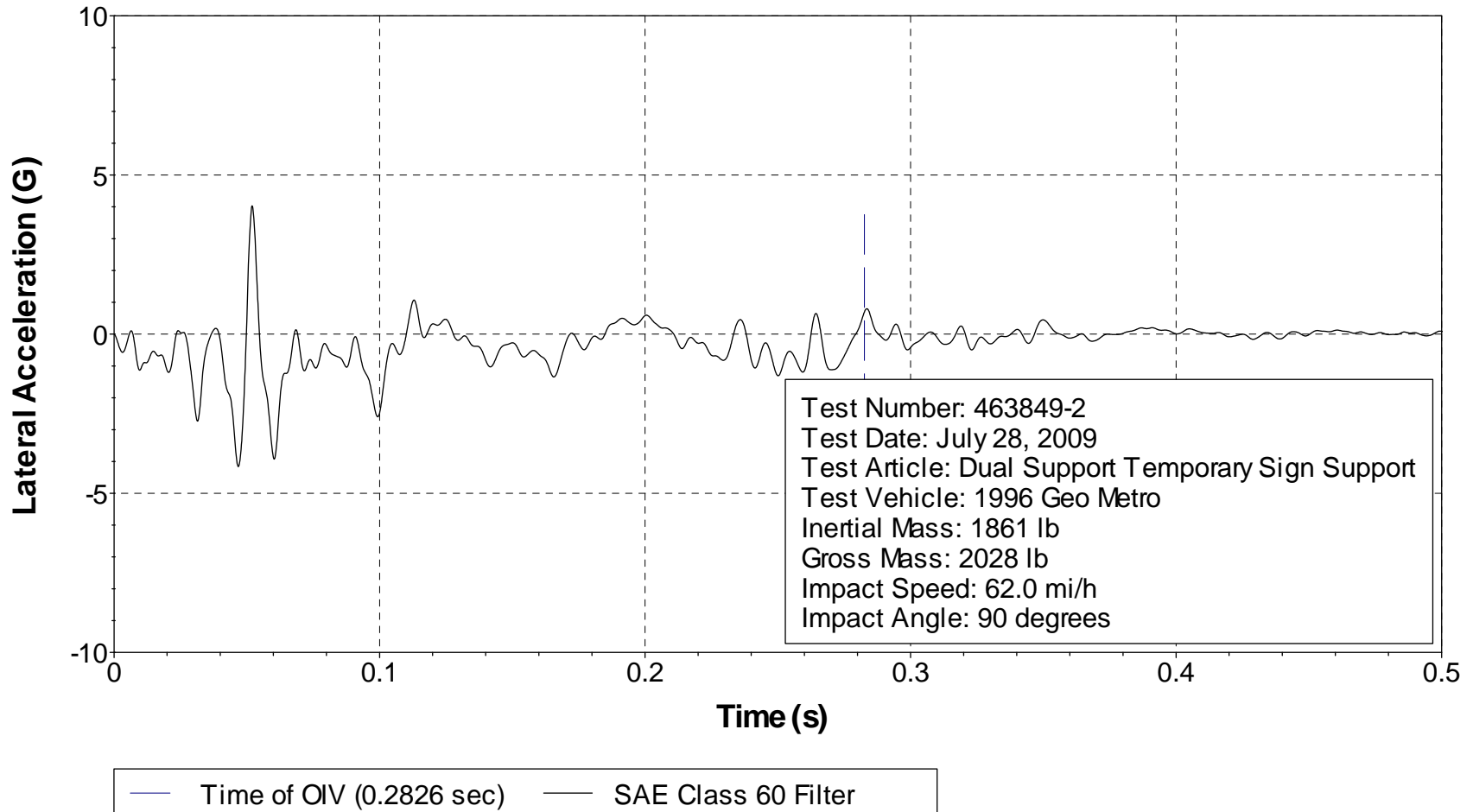


Figure D10. Vehicle Lateral Accelerometer Trace for Test 463849-2 (Accelerometer Located at Center of Gravity).

## Z Acceleration at CG

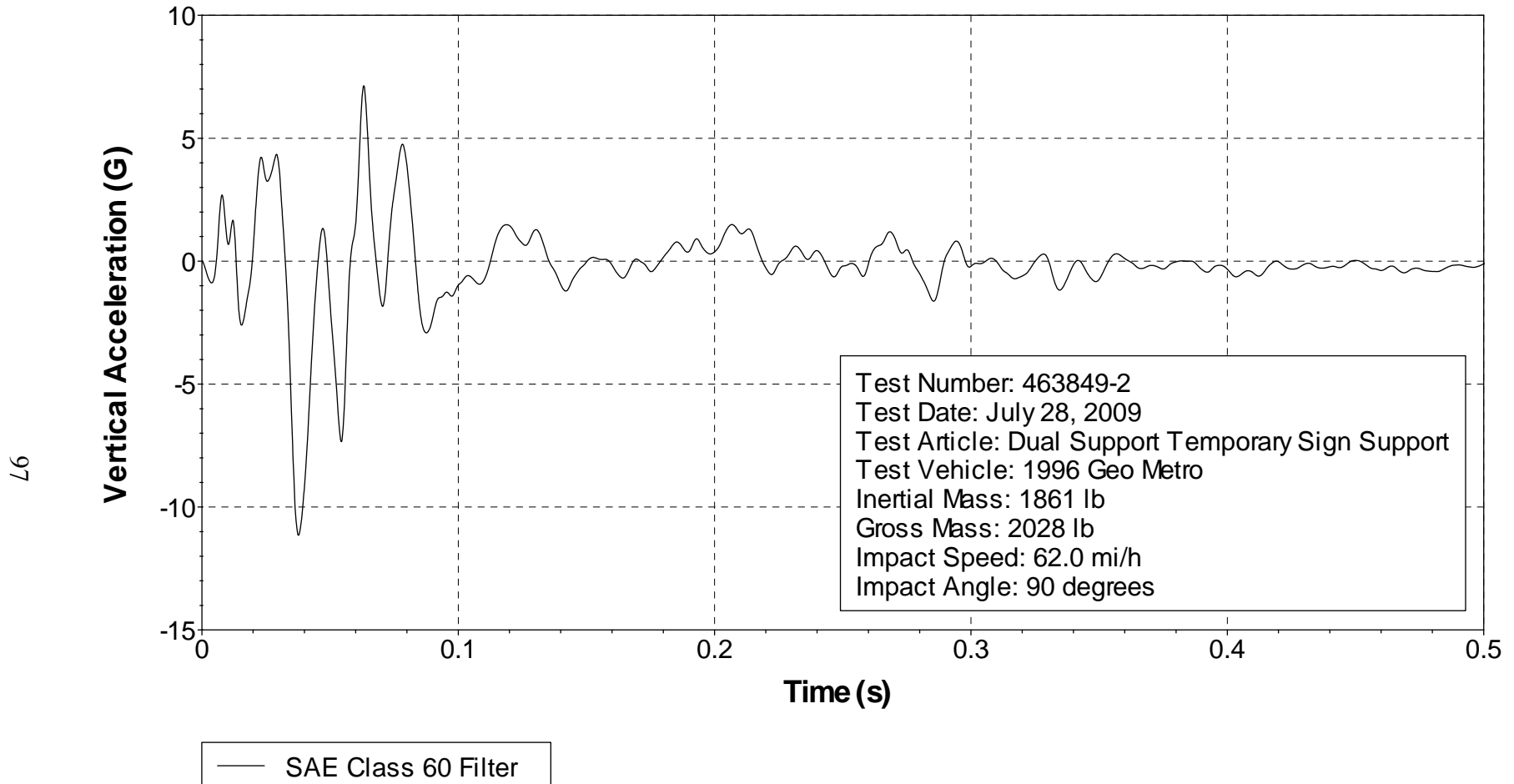
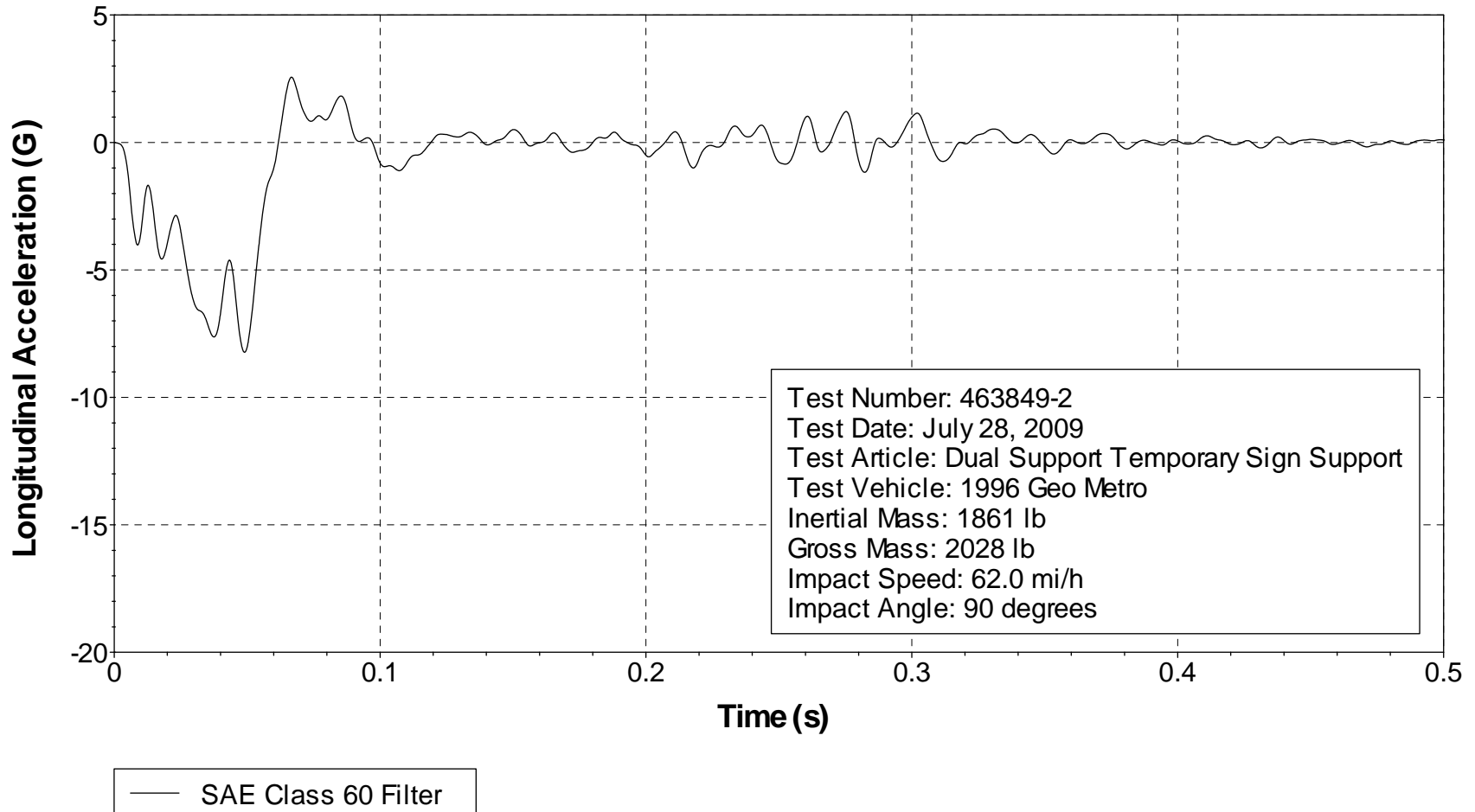


Figure D11. Vehicle Vertical Accelerometer Trace for Test 463849-2 (Accelerometer Located at Center of Gravity).

## *X Acceleration over Rear Axle*



**Figure D12. Vehicle Longitudinal Accelerometer Trace for Test 463849-2 (Accelerometer Located over Rear Axle).**

## Y Acceleration over Rear Axle

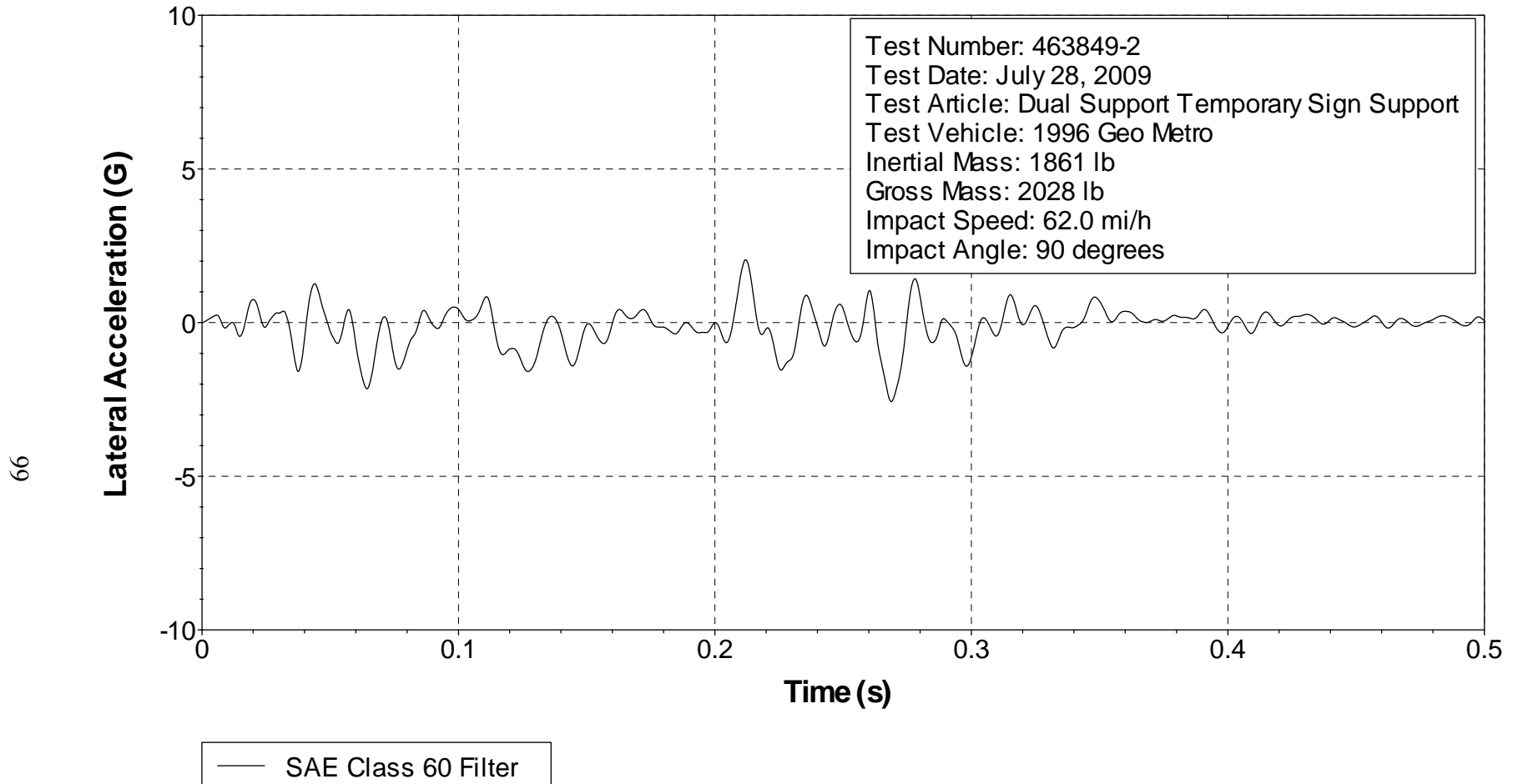


Figure D13. Vehicle Lateral Accelerometer Trace for Test 463849-2 (Accelerometer Located over Rear Axle).

## Z Acceleration over Rear Axle

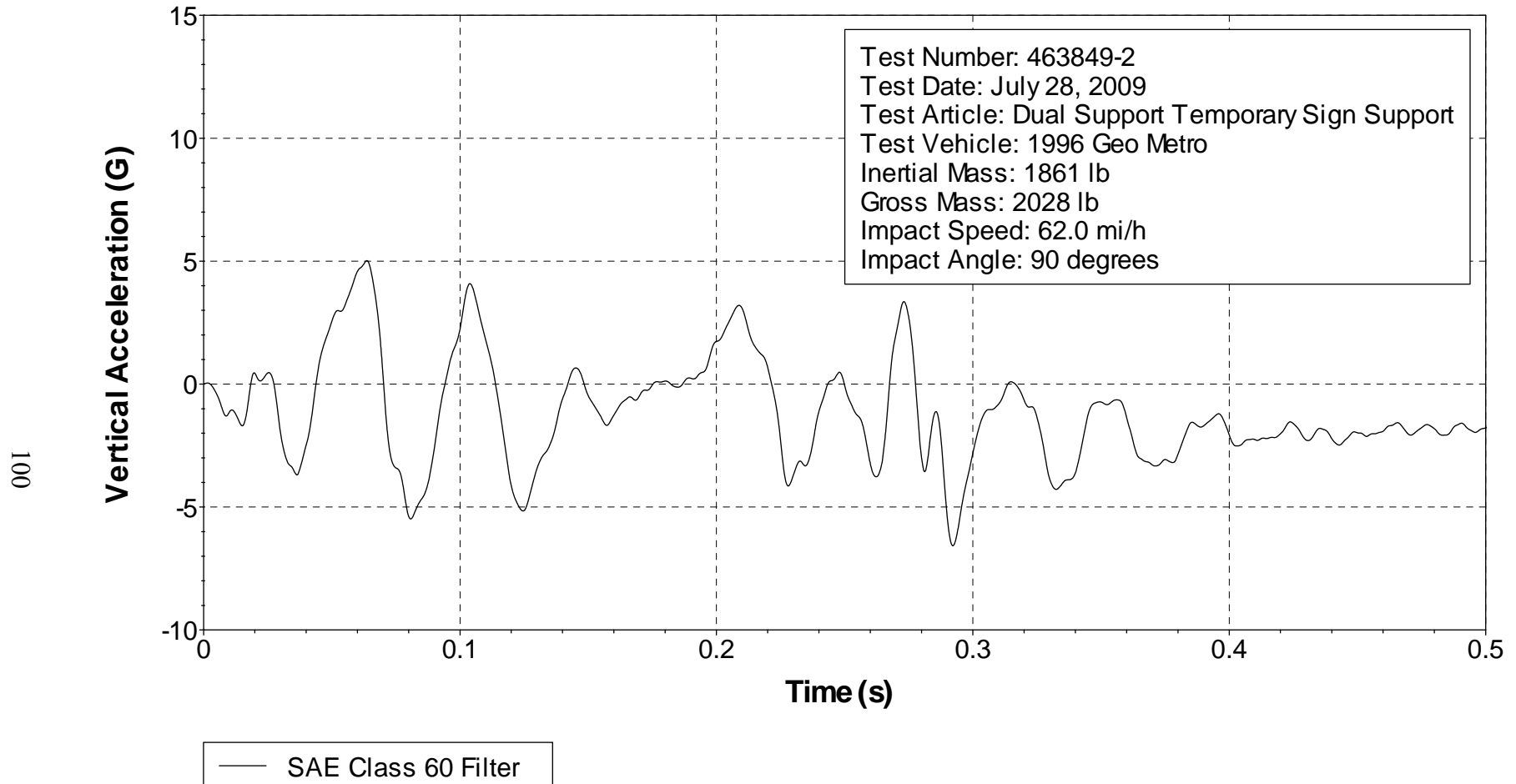


Figure D14. Vehicle Vertical Accelerometer Trace for Test 463849-2 (Accelerometer Located Over Rear Axle).



**APPENDIX E:  
AASHTO'S SIGN SHEETING SPECIFICATION**

---

Standard Specification for  
Retroreflective Sheeting for Traffic Control

---

**AASHTO Designation: M 268-09**



**American Association of State Highway and Transportation Officials  
444 North Capitol Street N.W., Suite 249  
Washington, D.C. 20001**

---

## Standard Specification for

# Retroreflective Sheeting for Traffic Control

## AASHTO Designation: M 268-09

---

### 1. SCOPE

- 1.1. This specification covers retroreflective sheeting and translucent overlay films intended for use on traffic control signs, delineators, barricades and other devices. The sheeting serves as the reflectorized background for sign messages and legends and symbols applied to the reflectorized background. Messages may be applied in opaque black or transparent colors.
- 1.2. All material furnished under this specification shall have been manufactured within 18 months of the delivery date. All material shall be supplied by the same manufacturer.
- 1.3. The values stated in inch-pound units are to be regarded as the standard.
- 1.4. This specification does not purport to address all of the safety concerns, if any, associated with its use. It is the responsibility of the user of this standard to establish appropriate safety and health practices and determine the applicability of regulatory limitations prior to use.
- 

### 2. REFERENCED DOCUMENTS

- 2.1. *ASTM Standards:*
- B 209, Specification for Aluminum and Aluminum-Alloy Sheet and Plate
  - B 449, Specification for Chromates on Aluminum
  - D 523, Test Method for Specular Gloss
  - E 308, Practice for Computing the Colors of Objects by Using the CIE System
  - E 810, Test Method for Coefficient of Retroreflection of Retroreflective Sheeting Utilizing the Coplanar Geometry
  - E 811, Practice for Measuring Colorimetric Characteristics of Retroreflectors Under Nighttime Conditions
  - E 991, Practice for Color Measurement of Fluorescent Specimens Using the One-Monochromator Method
  - E 1164, Practice for Obtaining Spectrometric Data for Object-Color Evaluation
  - E 1347, Test Method for Color and Color-Difference Measurement by Tristimulus Colorimetry
  - E 1349, Test Method for Reflectance Factor and Color by Spectrophotometry Using Bidirectional (45°:0° or 0°:45°) Geometry
  - E 2152, Practice for Computing the Colors of Fluorescent Objects from Bispectral Photometric Data
  - E 2153, Practice for Obtaining Bispectral Photometric Data for Evaluation of Fluorescent Color
  - E 2301, Test Method for Daytime Colorimetric Properties of Fluorescent Retroreflective Sheeting and Marking Materials for High Visibility Traffic Control and Personal Safety Applications Using 45°:Normal Geometry
  - G 151, Practice for Exposing Nonmetallic Materials in Accelerated Test Devices that Use Laboratory Light Sources
-

2.2.

*Federal Standards:*

U. S. Department of Transportation, Federal Highway Administration, Standard Color Tolerance Charts

---

### 3. DISCUSSION

- 3.1. The retroreflective sheeting classifications established in this specification are not intended to describe any specific materials, but are instead intended to establish meaningful minimum retroreflectivity intervals. These intervals are correlated with human performance factors by which sheeting may be classified.
- 3.2. Classifications are provided as a means for differentiating functional performance based on minimum retroreflectivity levels at standard combinations of entrance and observation angles. The combinations of entrance and observation angles shown in this specification provide a mechanism to categorize retroreflective sheeting materials into Type classifications. It should be recognized that performance characteristics outside these standard geometries cannot always be reasonably predicted, especially for retroreflective sheeting of microprismatic construction, and may vary between particular products meeting the same Type. It is the responsibility of the user of this specification to determine the suitability of any reflective sheeting material for its intended application.
- 3.3. When tested in accordance with ASTM E 810, the average coefficient of retroreflection (RA) for a set of three samples taken from the same roll must not vary more than 20 percent between RA measured at 0, 45, 90 and 120 degrees of rotation in order to be considered rotationally insensitive. Other rotational angles can be specified for testing by the user. The test shall be conducted at an observation angle of 0.5 degrees and an entrance angle of -4.0 degrees. Other combinations of observation and entrance angle can be specified for testing by the user. Calculate the percent difference by dividing the absolute difference between RA (0) and RA (45) by RA (0). Repeat the calculation replacing RA (45) with RA (90) and RA (120). RA (0) is established with the sheeting aligned in its optimum rotation.
- 3.3.1. For sheeting not meeting the 20% maximum rotational sensitivity requirement, the manufacturer must provide identification marks or other features (such as a datum mark, tiles, or distinct seal pattern) in or on the sheeting face denoting the optimum orientation of the sheeting. The markings or features must be visible from a minimum distance of 2 ft. and must be arrayed in such a manner that they will be readily distinguishable on cut-out legends, symbols, or borders. The manufacturer must provide fabrication guidelines outlining optimum sheeting orientation upon user request.
- 3.3.2. When utilizing sheeting (for permanent signs) that does not meet the 20% maximum rotational requirement, fabricate signs by applying white sheeting for cut-out legends, symbols, borders, and route marker attachments within the parent sign face in the optimum rotation according to the identification markings; and apply all background sheeting uniformly oriented.
- 3.4. Delineators – Retroreflective sheeting materials suitable for use on delineators are typically of microprismatic construction. The Type of retroreflective sheeting shall be specified by the user.
- 3.5. Reboundable – Reboundable retroreflective sheeting materials are typically of encapsulated microscopic glass bead lens or unmetallized microprismatic construction. These materials are suitable for use on flexible impact resistant plastic devices, such as traffic drum-like channelizing devices and tubular markers, and would typically be used on all classes of rural roads, highways and urban streets. This characteristic may be specified by the user.

---

## 4. CLASSIFICATIONS

4.1. This specification establishes four Types of retroreflective sheeting, with successively increasing minimum coefficients of retroreflection. Retroreflective sheeting materials shall meet all of the performance requirements in Section 5 to qualify as a particular Type under this specification. Minimum coefficients of retroreflection are shown in Tables 6, 7, 8 and 9 for retroreflective sheeting Type A, Type B, Type C and Type D respectively. The designated Type is exclusive to the highest specified minimum RA satisfied at observation angle of 0.5 degrees and an entrance angle of -4.0 degrees. Using higher retroreflectivity sheeting to manufacture signs where lower retroreflectivity sheeting Types are specified must be approved by the end user.

4.2. The following are general descriptions of the Types of retroreflective sheeting established by this specification. These are provided for descriptive information only and are not intended to be limitations or recommendations.

Note 1-The Manual on Uniform Traffic Control Devices (MUTCD) requires that traffic control signs, unless illuminated, be retroreflective to show the same shape and similar color both day and night. Therefore, any retroreflective sheeting materials meeting this specification would satisfy that requirement. However, when determining the appropriateness of a particular Type of sheeting for a particular application, consideration should be given to the pertinent highway characteristics where the materials will be installed, such as traffic volumes, traffic speeds, and roadway geometrics, as well as available resources. Brighter materials (meeting Type B, C or D) should be considered for use on complex roadway environments where the driving task may be more involved.

4.2.1 Type A – Retroreflective sheeting materials meeting Type A are typically constructed of encapsulated microscopic glass bead lens construction.

4.2.2. Type B – Retroreflective sheeting materials meeting Type B are typically constructed of unmetallized microprismatic optics. These triangular microprismatic materials do not have a significant 1 degree observation angle performance.

4.2.3. Type C – Retroreflective sheeting materials meeting Type C are typically constructed of unmetallized microprismatic optics. These triangular microprismatic materials have a significant 1 degree observation angle performance.

4.2.4. Type D – Retroreflective sheeting materials meeting Type D are typically constructed of unmetallized microprismatic optics. These materials have 0.5 and 1 degree observation angle performance two times greater than Type C materials.

4.3. Adhesive Backing Classes – The adhesive backing classes shall be classified as follows:

4.3.1. Class 1 – The adhesive backing shall be pressure-sensitive and require no heat, solvent, or other preparation for adhesion to smooth, clean surfaces.

4.3.2. Class 2 – The adhesive backing shall be activated by applying heat and pressure to the material. The temperature necessary to form a durable permanent bond shall be a minimum of 66°C (150°F). Reflective sheeting materials with Class 2 adhesive shall be repositionable under normal shop conditions and at substrate temperatures up to 38°C (100°F) without damage to the sheeting. Reflective sheeting materials with Class 2 adhesive may be perforated to facilitate removal of air in heat-vacuum laminators, but the

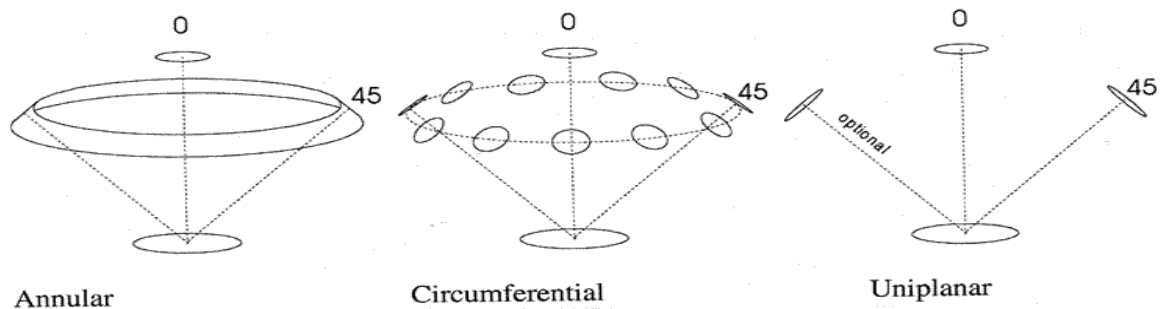
perforations must be of a size and frequency such that they do not cause objectionable blemishes in the finished sign.

- 4.3.3. Class 3 – The adhesive backing shall be a positionable low-tack pressure-sensitive adhesive that requires no heat, solvent, or other preparation for adhesion to smooth, clean surfaces. Reflective sheeting materials with Class 3 adhesive shall be repositionable up to a temperature of 38°C (100°F) without damage to the sheeting.
- 4.3.4. Class 4 – The adhesive backing shall be a low-temperature pressure-sensitive adhesive that permits sheeting applications down to -7°C (+20°F) without the aid of heat, solvent, or other preparation for adhesion to smooth, dry, and clean surfaces.

---

## 5. SHEETING PROPERTIES

- 5.1. Test Conditions. Unless otherwise specified in this specification, condition all adhesively bonded and unbonded test samples and specimens at a temperature of 73 ± 3°F (23 ± 2°C) and 50 ± 5 % relative humidity for 24 hours prior to testing.
- 5.2. Panel Preparation. Unless otherwise specified in this specification, when tests are to be performed using test panels, apply the specimens of retroreflective material to smooth aluminum cut from Alloy 6061-T6 or 5052-H38, in accordance with Specification ASTM B 209 or ASTM B 209M. The sheets shall be 0.020 in. (0.508 mm), 0.040 in. (1.016 mm), or 0.063 in. (1.600 mm) in thickness, and a minimum of 8 by 8 in. (200 by 200 mm). Prepare the aluminum in accordance with Specification ASTM B 449, Class 2, or degrease and lightly acid etch before the specimens are applied. Apply the specimens to the panels in accordance with the recommendations of the retroreflective sheeting manufacturer.
- 5.3. Adhesive. The sheeting shall have a Class 1, 2, 3 or 4 adhesive as specified by the end user. For testing purposes, subject two pieces of reflective sheeting, each 2 in. by 6 in. (51 mm by 152 mm) in size, to a temperature of 160°F (71°C) and a pressure of 2.5 pounds per square inch (0.176 kg/cm<sup>2</sup>) for 4 hours. Bring the pieces to equilibrium at standard conditions and cut one, 1 in. by 6 in. (25 mm by 152 mm) specimen from each piece and remove the liner by hand. The liner shall be removed by peeling without soaking in water or other solution, and shall not break, tear or remove any adhesive from the backing. Apply 4 in. (102 mm) of one end of each specimen to a test panel. Condition as specified in Section 5.1. Suspend the panels in a horizontal position with the specimen facing downward. The adhesive backing of the retroreflective sheeting shall produce a bond that will support a 1¾ lb (0.79kg) weight for adhesive classes 1, 2, and 3 or a 1lb (0.45kg) weight for adhesive class 4 for 5 min, without the bond peeling for a distance of more than 2 in. (51 mm). The test panel must have a minimum thickness of 0.040 in. (1.016 mm).
- 5.4. Liner Removal. The liner, when provided, shall be easily removed without soaking in water or other solutions, and shall not break, tear, or remove adhesive from the sheeting. The protective liner, if any, shall be easily removed following accelerated storage for 4 hours at 160°F (71°C) under a weight of 2.5 psi (17.2 kPa).
- 5.5. Daytime Color. Determine the chromaticity and luminance factor %Y for CIE standard illuminant D65 and the 1931 CIE 2° standard observer in accordance with Practice ASTM E 308, Test Methods ASTM E 1347, ASTM E 1349, and ASTM E 2301, and Practices ASTM E 991, ASTM E 1164, ASTM E 2152, and ASTM E 2153, as applicable. The luminance factor is the sum of the reflectance luminance factor and the fluorescence luminance factor. Bispectral measurement provides the individual factors, while measurement with simulated D65 provides their sum.



For fluorescent specimens, it is necessary either that the physical illumination of the specimen be a good approximation to illuminant D65, requiring an instrument with an appropriately filtered light source, or else that a bispectral photometer conforming to Test Method E 2301 be used.

There are three types of 45/0 (0/45) instruments: annular, circumferential and uniplanar. Measurement of prismatic sheeting with circumferential instruments may require multiple measurements. Measurement of prismatic sheeting with uniplanar instruments will require multiple measurements.

If the measurement geometry is circumferential, then the testing laboratory must verify that the apertures in the ring are sufficiently close for acceptable approximation to an annular measurement. This may depend on the optical construction of the specimen, and must be determined by the testing laboratory. Multiple measurements of the same specimen area at different rotations may be averaged to improve the approximation to an annular measurement.

If the measurement geometry is uniplanar, then a sequence of measurements shall be made on the same specimen area at incremental rotations, and the measurement values shall be taken as averages over all the rotations. The number of rotations shall be large enough for acceptable approximation to an annular measurement. The number depends on the optical construction of the specimen and must be determined by the testing laboratory.

Instruments (spectrophotometers, colorimeters) used to measure daytime color shall have 45/0 or 0/45 illumination and viewing geometry. The referee instrument shall have 10° apertures for both illumination and viewing. Use of aperture sizes deviating from these may affect the measurement results.

- 5.6. Nighttime color. Nighttime color shall be determined in accordance with Practice ASTM E 811 and evaluated using the CIE system in Practice ASTM E 308. (The saturation limit shall be considered to extend to the boundary of the chromaticity locus of spectral colors.) Measure using CIE Illuminant A, observation angle of 0.33 degrees, entrance angle of +5 degrees, source, and receiver apertures not exceeding 10 minutes of arc, CIE 1931 (2 degree) standard observer.
- 5.7. Color. When evaluated according to 5.5 and 5.6, the sheeting shall be uniform in color and devoid of streaks throughout the length of each lot or roll. Shheeting used for side by side overlay applications shall have a Hunter Lab Delta E of less than 3 units. The sheeting shall conform to the daytime and nighttime color requirements of the following tables.

**TABLE 1 Daytime Luminance Factor (%Y)  
Types A, B, C and D**

Color	Minimum	Minimum for Higher Daytime Conspicuity (*)	Maximum
White	27	40	...
Yellow	15	24	45
Orange	12	14	30
Green	3.0		12
Red	2.5		15
Blue	1.0		10
Brown	1.0		9.0
Fluorescent Yellow-Green (**)	60		None
Fluorescent Yellow (**)	45		None
Fluorescent Orange (**)	25		None

\*Minimum values for higher daytime conspicuity are supplementary requirements that apply when specified by the end user.

\*\*The luminance factors for fluorescent colors shown in Table 1 consist of the sum of a reflectance luminance factor and fluorescence luminance factor. The luminance factor may be determined using a good approximation to illuminant D65, requiring an instrument with an appropriately filtered light source, or a bispectral photometer conforming to Test Method ASTM E 2301 be used.

**TABLE 2 Color Specification Limits (Daytime)  
Types A, B, C and D**

Color	1		2		3		4	
	x	y	x	y	x	y	x	y
White	0.303	0.300	0.368	0.366	0.340	0.393	0.274	0.329
Yellow	0.498	0.412	0.557	0.442	0.479	0.520	0.438	0.472
Orange	0.558	0.352	0.636	0.364	0.570	0.429	0.506	0.404
Green	0.026	0.399	0.166	0.364	0.286	0.446	0.207	0.771
Red	0.648	0.351	0.735	0.265	0.629	0.281	0.565	0.346
Blue	0.140	0.035	0.244	0.210	0.190	0.255	0.065	0.216
Brown	0.430	0.340	0.610	0.390	0.550	0.450	0.430	0.390
Fluorescent Yellow-Green	0.387	0.610	0.369	0.546	0.428	0.496	0.460	0.540
Fluorescent Yellow	0.479	0.520	0.446	0.483	0.512	0.421	0.557	0.442
Fluorescent Orange	0.583	0.416	0.535	0.400	0.595	0.351	0.645	0.355

The four pairs of chromaticity coordinates determine the acceptable color in terms of the CIE 1931 Standard Colorimetric System measured with CIE Standard Illuminant D65.

The saturation limit of green and blue may extend to the border of the CIE chromaticity locus for spectral colors.

**TABLE 3 Color Specification Limits (Nighttime)  
Types A, B, C and D**

Color	1		2		3		4	
	x	y	x	y	x	y	x	y
White (NA)								
Yellow	0.513	0.487	0.500	0.470	0.545	0.425	0.572	0.425
Orange	0.595	0.405	0.565	0.405	0.613	0.355	0.643	0.355
Green	0.007	0.570	0.200	0.500	0.322	0.590	0.193	0.782
Red	0.650	0.348	0.620	0.348	0.712	0.255	0.735	0.265
Blue	0.033	0.370	0.180	0.370	0.230	0.240	0.091	0.133
Brown	0.595	0.405	0.540	0.405	0.570	0.365	0.643	0.355
Fluorescent Yellow-Green	0.480	0.520	0.473	0.490	0.523	0.440	0.550	0.449
Fluorescent Yellow	0.554	0.445	0.526	0.437	0.569	0.394	0.610	0.390
Fluorescent Orange	0.625	0.375	0.589	0.376	0.636	0.330	0.669	0.331

- 5.8. Accelerated Laboratory Weathering. Accelerated laboratory weathering will be used for provisional qualification of sheeting before the results from accelerated outdoor weathering are available. When they become available, the results from outdoor weathering take precedence over the results from laboratory-accelerated weathering tests.
- 5.8.1. Accelerated laboratory weathering testing will be performed for 2200 hours according to ASTM G 151 and ASTM G 155, Cycle 1. Following weathering, gently wash the panels using a soft cloth or sponge and clean water or a dilute solution of a mild detergent (1% by weight in water, maximum concentration). After washing, rinse thoroughly with clean water, and blot dry with a soft clean cloth. Following cleaning, the applied sheeting shall show no appreciable discoloration, cracking, streaking, crazing, blistering, or dimensional change. The sheeting shall exhibit a Hunter Lab Delta E of 5 or less when compared to the sample prior to exposure. In addition, the chromaticity coordinates, after exposure, must remain within the appropriate four pairs of chromaticity values listed in Tables 2 and 3. Following accelerated outdoor weathering, the sheeting shall exhibit a minimum of 80 percent of the coefficient of retroreflection for the particular Type as listed in Tables 4, 5, 6 and 7.
- 5.8.2. Accelerated laboratory weathering testing may be performed by an alternate method, as identified in ASTM G 151, as approved by the user.
- 5.9. Accelerated Outdoor Weathering. Accelerated outdoor weathering will be performed at an acceptable location as approved by the user, or by default, in climates equivalent to Phoenix, AZ and Miami, FL. Sheeting material shall be open backed and placed on an outdoor rack with a 45 degree angle facing the equator. Labeling, conditioning and handling of panels prior to exposure and during evaluation periods shall be in accordance with ASTM Practice G 147. The sheeting will be evaluated annually for three years. Following weathering, gently wash the panels using a soft cloth or sponge and clean water or a dilute solution of a mild detergent (1% by weight in water, maximum concentration). After washing, rinse thoroughly with clean water, and blot dry with a soft clean cloth. After washing and drying, condition the panels at room temperature for at least 2 hours prior to conducting any measurements. After panels have been washed, dried, and conditioned, the applied sheeting shall show no appreciable discoloration, cracking, streaking, crazing, blistering, or dimensional change. The sheeting shall exhibit a Hunter Lab Delta E of 5 or less when compared to the sample prior to exposure. In addition, the chromaticity coordinates, after exposure, must remain within the appropriate four pairs of chromaticity values listed in Tables 3 and 4. Following accelerated outdoor weathering, the sheeting shall exhibit a minimum of 80 percent of the coefficient of retroreflection for the particular Type as listed in Tables 4, 5, 6 and 7.



- 5.10. Shrinkage. Condition a 9 in. (230mm) by 9 in. (230mm) retroreflective sheeting specimen with liner, a minimum of 1 hour at standard conditions (see 5.1). Remove the liner and place the specimen on a flat surface with the adhesive side up. Ten minutes after the liner is removed and again after 24 hours, measure the specimen to determine the amount of dimensional change. The sheeting shall not shrink in any dimension more than 1/32 in. (0.8 mm) in ten minutes and not more than 1/8 in. (3 mm) in 24 hours.
- 5.11. Workability. The sheeting shall show no cracking, scaling, pitting, blistering, edge lifting, inter-film splitting, curling, or discoloration when processed and applied using mutually acceptable processing and application procedures.
- 5.12. Positionability. Shheeting, with Class 3 adhesive, used for manufacturing legends and borders shall provide sufficient positionability during the fabrication process to permit removal and reapplication without damage to either the legend or sign background and shall have a plastic liner suitable for use on bed cutting machines. Thereafter, all other adhesive and bond requirements contained in the specification shall apply.
- Positionability shall be verified by cutting 4 in. (100 mm) letters E, I, K, M, S, W, and Y out of the positionable material. The letters shall then be applied to a sheeted aluminum blank using a single pass of a two pound roller. The letters shall sit for five minutes and then a putty knife shall be used to lift a corner. The thumb and fore finger shall be used to slowly pull the lifted corner to lift letters away from the sheeted aluminum. The letters shall not tear or distort when removed.
- 5.13. Thickness. The thickness of the sheeting without the protective liner shall be less than or equal to 0.015 in. (0.4 mm), or 0.025 in. (0.6 mm) for prismatic material.
- 5.14. Processing. The sheeting shall permit cutting and color processing according to the sheeting manufacturer's specifications at temperatures of 60 to 100 °F (15 to 38 °C) and within a relative humidity range of 20 to 80 percent. The sheeting shall be heat resistant and permit forced curing without staining the applied or unapplied sheeting at temperatures recommended by the manufacturer. The sheeting shall be solvent resistant and capable of being cleaned with VM&P naphtha, mineral spirits, and turpentine.
- 5.14.1. Transparent color and opaque black inks shall be single component and low odor. The inks shall dry within eight hours and not require clear coating. After color processing on white sheeting, the sheeting shall show no appreciable discoloration, cracking, streaking, crazing, blistering, or dimensional change when tested for durability (5.9 and 5.10). The ink on the weathered, prepared panel shall exhibit a Hunter Lab Delta E of 5 or less when compared to the original.
- 5.14.2. Transparent color electronic cutting films shall be acrylic. After application to white sheeting, the films shall show no appreciable discoloration, cracking, streaking, crazing, blistering, or dimensional change when tested for durability (5.9 and 5.10). The films on the weathered, prepared panel shall exhibit a Hunter Lab Delta E of 5 or less when compared to the original.
- 5.14.3. Black screen ink, when applied to white sheeting, must be completely opaque.
- 5.15. Transparent colors screened, or transparent acrylic electronic cutting films, on white sheeting, shall meet the minimum coefficient of retroreflection values as listed in Tables 4, 5, 6 and 7 for the color applied. After accelerated laboratory and accelerated outdoor testing, the colors shall retain a minimum 80 percent of the coefficient of retroreflection as listed in Tables 4, 5, 6 and 7.
- 5.16. Identification. The sheeting shall have a distinctive overall pattern in the sheeting unique to the manufacturer. If material orientation is required for optimum retroreflectivity, permanent orientation marks shall be incorporated into the face of the sheeting. Neither the overall pattern nor the orientation marks shall interfere with the reflectivity of the sheeting.

- 5.17. Packaging. Both ends of each box shall be clearly labeled with the sheeting type, color, adhesive type, manufacturer's lot number, date of manufacture, and supplier's name. Material Safety Data Sheets and technical bulletins for all materials shall be furnished to the Agency with each shipment.
- 5.18. Coefficient of Retroreflection. The coefficient of retroreflection (RA) is expressed using the units of cd/lux/m<sup>2</sup> (cd/ft<sup>2</sup>) and determined in accordance with ASTM E 810. When no rotation angle is specified, measurements are taken at 0 and 90 degrees and then averaged. Compliance with the minimum coefficient of retroreflection for the 1.0° observation angle is required for Types C and D. Compliance with the minimum coefficient of retroreflection for the 1.0° observation angle is required for Types A and B when specified by the end user.

**Table 4 - Minimum Coefficient of Retroreflection (RA) for Type A Sheeting**

Observation Angle (deg.)	Entrance Angle (deg.)	White	Yellow	Orange	Red	Green	Blue	Brown
0.2	-4	240	180	90	35	25	12	7.5
0.2	+30	120	90	45	20	12	6.0	3.5
0.5	-4	95	70	35	15	9.5	4.5	3.0
0.5	+30	50	35	20	7.0	4.5	2.5	1.5
1.0	-4	4.5	3.5	1.8	0.7	0.5	0.3	0.2
1.0	+30	2.5	2.0	1.0	0.5	0.3	0.2	0.1

**Table 5 - Minimum Coefficient of Retroreflection (RA) for Type B Sheeting**

Observation Angle (deg.)	Entrance Angle (deg.)	White	Yellow	Orange	Red	Green	Blue	Brown	FYG	FY	FO
0.2	-4	335	250	125	50	35	17	10	270	200	100
0.2	+30	120	85	45	17	12	6.0	3.5	95	70	35
0.5	-4	135	100	50	20	14	6.5	4.0	110	80	40
0.5	+30	45	35	17	7.0	4.5	2.5	1.5	35	25	15
1.0	-4	15	12.5	6.5	2.5	1.5	1.0	0.5	15	10	5.0
1.0	+30	5.5	4.5	2.5	1.0	0.5	0.3	0.2	4.5	3.5	1.5

**Table 6 - Minimum Coefficient of Retroreflection (RA) for Type C Sheeting**

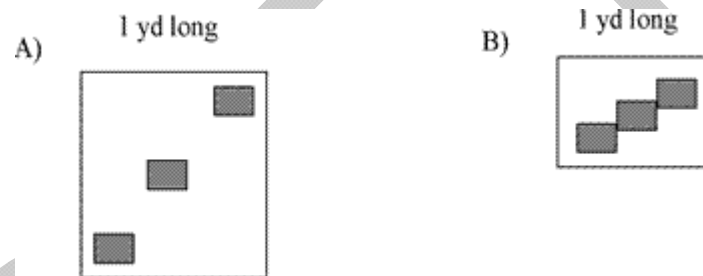
Observation Angle (deg.)	Entrance Angle (deg.)	White	Yellow	Orange	Red	Green	Blue	Brown	FYG	FY	FO
0.2	-4	580	440	220	85	60	30	17	465	350	175
0.2	+30	200	150	75	30	20	10	6.0	160	120	60
0.5	-4	235	175	85	35	25	12	7.0	190	140	70
0.5	+30	80	60	30	10	8.0	4.0	2.5	65	50	25
1.0	-4	60	45	20	8.5	5.5	3.0	1.8	45	35	17.5
1.0	+30	20	15	7.5	3.0	2.0	1.0	0.5	15	12	6.0

**Table 7 - Minimum Coefficient of Retroreflection (RA) for Type D Sheeting**

Observation Angle (deg.)	Entrance Angle (deg.)	White	Yellow	Orange	Red	Green	Blue	Brown	FYG	FY	FO
0.2	-4	580	440	220	85	60	30	17	465	350	175
0.2	+30	200	150	75	30	20	10	6.0	160	120	60
0.5	-4	465	350	175	70	45	23	14	375	280	140
0.5	+30	160	120	60	25	16	8.0	5.0	130	95	50
1.0	-4	120	85	45	17	10	6.0	3.5	95	70	35
1.0	+30	40	30	15	6.0	4.0	2.0	1.0	35	25	12

## 6. SAMPLING

- 6.1. Sampling. A full width by 1 yard (0.9 m) long sample is selected at random to represent the entire sheet, roll or lot. Three samples will be taken from the selected sample. For the purpose of testing the coefficient of retroreflectivity, three samples shall be spaced evenly across (left, center and right) and spaced evenly down the specimen as shown below.



For determining conformance to all other requirements, single samples taken at random shall be tested.

For the purpose of testing, and qualification, producers shall include a physical sample with the following information:

- 6.1.1 Company name
- 6.1.2. Physical and mailing address
- 6.1.3. Company's material designation (product name, style number, etc.)
- 6.1.4. Contact person and phone number
- 6.1.5. AASHTO sheeting type
- 6.1.6. AASHTO backing class

## APPENDIX

(Non-mandatory Information)

### PROCEDURE FOR ESTABLISHMENT OF MINIMUM COEFFICIENTS OF RETROREFLECTION

The retroreflective sheeting grades established in this specification are not intended to describe any specific materials. The following information serves to explain the theory and research applied to the creation of the values.

**White Sheeting** – for white sheeting within a particular grade, the relationships for minimum coefficients of retroreflection for the various standard combinations of observation and entrance angles are shown in Table A1.1.

**Notes** – The basic facts for each value listed in the tables for the coefficient of retroreflection are found in Table A1.2.

**Colored Sheeting** – For colored sheeting within a particular grade, the factors shown in Table A1.3 are applied to the minimum coefficients of retroreflection obtained for white sheeting for that grade in Table A1.1.

**Table A1.1 Minimum Coefficients of Retroreflection (RA) for White Sheeting within a Grade**

Observation Angle	Entrance Angle	AASHTO Sheeting Type			
		A	B	C	D
0.2	-4	240	335	580	580
0.2	30	120	120	200	200
0.5	-4	95	135	235	465
0.5	30	50	45	80	160
1.0	-4	4.5	15	60	120
1.0	30	2.5	5.5	20	40

#### Underlying thoughts

- Build a simple specification table that is supported through research findings-for instance, psychophysical principles of vision vetted through over a century of research have shown through such mechanisms as threshold versus intensity relationships that human visual performance is roughly approximated using Weber's Law. In other words, as the baseline condition increases (in this case, sign luminance through retroreflective materials), we need larger differences in to observe measureable changes.
- Maintain known alpha and beta geometries from ASTM D4956.
- The lowest class is based on encapsulated beaded materials.
- Previous work has shown that of all the current ASTM D4956 alpha/beta geometries, the 0.5/-4.0 combination is best correlated with performance.

Using geometry of 0.5/-4.0, this specification uses increasing multipliers to set thresholds for class distinctions. Research has shown that the Class B and C materials have statistically longer legibility distances than Class A materials. While Classes B and C have about the same total light return, the returned light is spread more for Class C materials than it is for Class B materials. The wider spread of returned light may be useful for signs with small letters such as street name signs. Class D materials are similar to C materials in terms of the light distribution but Class D materials are more efficient with the light returned to the driver.

**Table A1.2 Specific Notes for the Development of the Recommendations**

<b>Obs. Angle</b>	<b>Entr. Angle</b>	<b>AASHTO Sheeting Type</b>			
		<b>A</b>	<b>B</b>	<b>C</b>	<b>D</b>
0.2	-4	$a * 2.5$	$b * 2.5$	$c * 2.5$	$c * 2.5$
0.2	30	$a * 1.25$	$b * 0.875$	$c * 0.875$	$c * 0.875$
0.5	-4	$a$	$b = \text{Sq. Root } 2 * a$	$c = \text{Sq. Root } 3 * b$	$d = \text{Sq. Root } 4 * c$
0.5	30	$a * 0.5$	$b * 0.35$	$c * 0.35$	$d * 0.35$
1.0	-4	$a * 0.05$	$b * 0.125$	$c * 0.25$	$d * 0.25$
1.0	30	$a * 0.05$	$b * 0.04375$	$c * 0.0875$	$d * 0.0875$

**Table A1.2 Minimum Coefficient of Retroreflection (RA) Factors for Colored Sheeting**

<b>Yellow</b>	<b>Orange</b>	<b>Red</b>	<b>Green</b>	<b>Blue</b>	<b>Brown</b>	<b>Fluorescent Yellow-Green</b>	<b>Fluorescent Yellow</b>	<b>Fluorescent Orange</b>
0.75	0.38	0.15	0.10	0.05	0.03	0.80	0.60	0.30

\*The above factors, when applied to the coefficients for white sheeting established in Table A1.1, establish minimum coefficients of retroreflection for colored sheeting materials.



**APPENDIX F:  
LEAD-FREE PAVEMENT MARKING EVALUATION MEASUREMENTS  
AND PHOTOS**

The tables in this appendix give the detailed results of the color and retroreflectivity measurements for the yellow thermoplastic markings with and without lead. Also included are the coordinates for the color box requirements for various specifications and images of the pavement markings over the course of the study period.

**Table F1. Color Specification for Yellow Pavement Markings.**

Agency	Specification	1		2		3		4	
		x	y	x	y	x	y	x	y
TxDOT	Daytime DMS-8220 [2007] (13)	0.470	0.455	0.510	0.489	0.490	0.432	0.537	0.462
TxDOT	Daytime DMS-8220 [2009] (14)	0.435	0.429	0.510	0.489	0.460	0.400	0.560	0.440
FHWA	Nighttime 30 meter (17)	0.473	0.453	0.510	0.490	0.508	0.415	0.575	0.425
FHWA	Daytime 45/0 (17)	0.420	0.440	0.460	0.400	0.490	0.510	0.560	0.440

**Table F2. Test Deck 1 US 79 Lead-Free Thermoplastic Data Summary.**

Attribute	Measurement Date	R <sub>L</sub>	x	y
30 meter retroreflectivity and nighttime color	7/31/2007	268	0.523	0.457
	11/1/2007	156	0.507	0.443
	2/28/2008	107	0.511	0.439
	7/1/2008	72	0.520	0.453
	10/21/2008	90	0.504	0.442
	2/6/2009	80	0.495	0.440
	5/4/2009	103	0.497	0.440
Attribute	Measurement Date	Y	x	y
Daytime Color D65 2°	7/31/2007	45.62	0.48	0.4561
	11/1/2007	26.49	0.4334	0.4213
	2/28/2008	25.27	0.4214	0.4099
	7/1/2008	23.89	0.4211	0.4126
	10/21/2008	23.96	0.4203	0.4129
	2/6/2009	20.76	0.4055	0.4027
	5/4/2009	27.48	0.4252	0.4158
Attribute	Measurement Date	Y	x	y
Daytime Color D65 10°	7/31/2007	43.05	0.502	0.4516
	11/1/2007	24.27	0.4389	0.4135
	2/28/2008	24.88	0.4355	0.4094
	7/1/2008	24	0.4318	0.4097
	10/21/2008	23.08	0.4281	0.4068
	2/6/2009	20.78	0.4133	0.3983
	5/4/2009	26	0.4301	0.4076
Attribute	Measurement Date	Y	x	y
Nighttime Color A 2°	7/31/2007	53.42	0.5465	0.4359
	11/1/2007	28.81	0.5261	0.4276
	2/28/2008	27.38	0.5221	0.4237
	7/1/2008	26.71	0.5202	0.4253
	10/21/2008	26.86	0.5207	0.4281
	2/6/2009	22.16	0.5085	0.4255
	5/4/2009	30.71	0.5229	0.4281



**Table F3. Test Deck 1 US 79 Leaded Thermoplastic Data Summary.**

Attribute	Measurement Date	R <sub>L</sub>	x	y
30 meter retroreflectivity and nighttime color	7/31/2007	225	0.519	0.447
	11/1/2007	146	0.517	0.453
	2/28/2008	98	0.525	0.449
	7/1/2008	79	0.529	0.443
	10/21/2008	99	0.510	0.452
	2/6/2009	85	0.504	0.448
	5/4/2009	88	0.508	0.444
Attribute	Measurement Date	Y	x	y
Daytime Color D65 2°	7/31/2007	-	-	-
	11/1/2007	30.19	0.4567	0.4442
	2/28/2008	33.26	0.453	0.4385
	7/1/2008	29.06	0.4553	0.4409
	10/21/2008	29.65	0.4481	0.4383
	2/6/2009	24.27	0.4308	0.4274
	5/4/2009	30.52	0.4469	0.4371
Attribute	Measurement Date	Y	x	y
Daytime Color D65 10°	7/31/2007	-	-	-
	11/1/2007	26.65	0.4623	0.4338
	2/28/2008	30.58	0.4588	0.4276
	7/1/2008	27.57	0.4707	0.4341
	10/21/2008	27.68	0.4553	0.429
	2/6/2009	22.89	0.4373	0.4183
	5/4/2009	27.14	0.4532	0.4267
Attribute	Measurement Date	Y	x	y
Nighttime Color A 2°	7/31/2007	-	-	-
	11/1/2007	34.37	0.5364	0.4334
	2/28/2008	34.56	0.5333	0.4293
	7/1/2008	31.85	0.5369	0.4312
	10/21/2008	32.71	0.5323	0.4333
	2/6/2009	25.51	0.5223	0.4313
	5/4/2009	33.1	0.5308	0.4323

**Table F4. Test Deck 2 SH 21 Lead-Free Thermoplastic Data Summary.**

Attribute	Measurement Date	R <sub>L</sub>	x	y
30 meter retroreflectivity and nighttime color	7/31/2007	194	0.527	0.446
	11/1/2007	177	0.510	0.448
	2/28/2008	155	0.510	0.452
	7/1/2008	120	0.529	0.447
	10/21/2008	200	0.502	0.446
	2/6/2009	192	0.504	0.444
	5/4/2009	190	0.508	0.437
Attribute	Measurement Date	Y	x	y
Daytime Color D65 2°	7/31/2007	44.92	0.4870	0.4546
	11/1/2007	33.79	0.4511	0.4313
	2/28/2008	30.47	0.4415	0.4220
	7/1/2008	30.29	0.4426	0.4212
	10/21/2008	35.33	0.4510	0.4309
	2/6/2009	31.17	0.4432	0.4267
	5/4/2009	32.94	0.4462	0.4274
Attribute	Measurement Date	Y	x	y
Daytime Color D65 10°	7/31/2007	43.05	0.5020	0.4516
	11/1/2007	31.81	0.4603	0.4232
	2/28/2008	28.95	0.4511	0.4149
	7/1/2008	29.25	0.4454	0.4117
	10/21/2008	32.94	0.4592	0.4219
	2/6/2009	29.86	0.4470	0.4160
	5/4/2009	30.66	0.4514	0.4174
Attribute	Measurement Date	Y	x	y
Nighttime Color A 2°	7/31/2007	52.78	0.5484	0.4324
	11/1/2007	39.25	0.5362	0.4289
	2/28/2008	33.41	0.5316	0.4255
	7/1/2008	35.10	0.5336	0.4251
	10/21/2008	39.47	0.5353	0.4292
	2/6/2009	35.23	0.5307	0.4289
	5/4/2009	36.77	0.5326	0.4287

**Table F5. Test Deck 3 SH 21 Leaded Spray Thermoplastic Data Summary.**

Attribute	Measurement Date	R <sub>L</sub>	x	y
30 meter retroreflectivity and nighttime color	9/25/2008	159	0.516	0.460
	1/7/2009	157	0.506	0.465
	4/8/2009	143	0.510	0.461
	7/2/2009	137	0.511	0.461
Attribute	Measurement Date	Y	x	y
Daytime Color D65 2°	9/25/2008	34.01	0.4747	0.4526
	1/7/2009	30.09	0.4555	0.4448
	4/8/2009	28.86	0.4558	0.4421
	7/2/2009	30.16	0.4591	0.4377

**Table F6. Test Deck 3 SH 21 Lead-Free Extruded Thermoplastic Double Drop Data Summary.**

Attribute	Measurement Date	R <sub>L</sub>	x	y
30 meter retroreflectivity and nighttime color	9/25/2008	190	0.506	0.445
	1/7/2009	189	0.499	0.450
	4/8/2009	212	0.498	0.450
	7/2/2009	203	0.502	0.449
Attribute	Measurement Date	Y	x	y
Daytime Color D65 2°	9/25/2008	34.92	0.483	0.4413
	1/7/2009	32.06	0.463	0.4346
	4/8/2009	32.88	0.4651	0.4336
	7/2/2009	34.59	0.4612	0.4291

**Table F7. Test Deck 3 SH 21 Lead-Free Extruded Thermoplastic Single Drop Data Summary.**

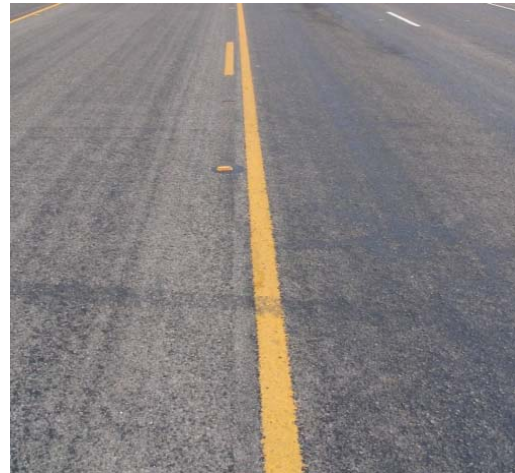
Attribute	Measurement Date	R <sub>L</sub>	x	y
30 meter retroreflectivity and nighttime color	9/25/2008	145	0.502	0.449
	1/7/2009	139	0.492	0.449
	4/8/2009	157	0.497	0.447
	7/2/2009	165	0.500	0.448
Attribute	Measurement Date	Y	x	y
Daytime Color D65 2°	9/25/2008	35.67	0.4858	0.4424
	1/7/2009	31.7	0.4561	0.4342
	4/8/2009	34.76	0.4662	0.4348
	7/2/2009	32.49	0.4602	0.428



Install 7.31.07



Leaded 11.12.07



Lead-Free 11.12.07



Leaded 7.1.08



Lead-Free 7.1.08

**Figure F1. Photos of US 79 Leaded and Lead-Free Thermoplastic Markings over Time.**



**Figure F1. Photos of US 79 Leaded and Lead-Free Thermoplastic Markings over Time (continued).**

