

# California's Suppression Statute—An Examination of Penal Code § 1538.5

TERRY J. KNOEPP\*

If a statute is drafted with clarity and has limited objectives, it is easy to analyze its application and to measure its effectiveness. But where a single statute has as its objective the radical restructuring of pretrial criminal procedure, an understanding of its impact and proper application becomes as difficult as it is necessary.

On November 7, 1967, the most far-reaching innovation in California criminal procedure became law. Senate Bill 88,<sup>1</sup> drafted in the Los Angeles District Attorney's Office, became California Penal Code § 1538.5<sup>2</sup>—the statutory motion to suppress evidence.

Its proponents were confident, its reception mixed, its subsequent history checkered. No other jurisdiction has anything quite like it. The statute certainly has not been ignored; it has been estimated

---

\* A.B., University of California; LL.B., University of California (Boalt Hall). Mr. Knoepp is Chief of the Appeals, Research, and Training Division of the San Diego County District Attorney's Office. This article was written in collaboration with Mr. Don Merkin, Staff Writer, San Diego Law Review. He has brought to the task an excellent analytical mind, a keen perception of the issues, and outstanding verbal skills. The author deeply appreciates Mr. Merkin's assistance.

1. S.B. 88 (Deukmejian) 1967 Sess. [Originally introduced as A.B. 1651 (Deukmejian) 1965 Sess.]

2. CAL. PEN. CODE § 1538.5 (West 1972).

that at least one-third of all felony cases utilize Penal Code § 1538.5, and castigation of crowded court calendars begins with criticism of suppression hearings.<sup>3</sup> Major restructuring of the criminal process has been necessitated. In San Diego County, for example, one day each week the criminal court system is devoted almost exclusively to suppression hearings. Jammed calendars have occasionally been the cause of misapplications of Penal Code § 1538.5 which frustrate its purpose, and prosecutors, defense attorneys, and judges have found reasons to both damn and praise it.

Yet in the five years since it was enacted, Penal Code § 1538.5 has never been subjected to an overall reevaluation.<sup>4</sup> Its provisions, together with subsequent judicial interpretations, have never been systematically analyzed. Its success in the light of the Legislature's original objectives has never been appraised.

This article discusses the practical application of Penal Code § 1538.5, including scope of coverage, procedure at the hearing, and appellate review; finally, there is an assessment of the statute's success and some suggested changes.

## I.

### BACKGROUND

Penal Code § 1538.5 was enacted following hearings and studies during 1965-1967 by the Assembly Interim Committee on Criminal Procedure. The end result of these studies was a series of recommendations, a substantial portion of which became law.<sup>5</sup> § 1538.5 provides a comprehensive scheme for challenging the introduction into evidence, and for the return of items unlawfully seized. It sets forth the proper time for such motions, the procedure for appellate review and for extraordinary writs, and other significant matters all relating to unlawful searches and seizures.

Until 1955 and the adoption of the Exclusionary Rule in *People v. Cahan*,<sup>6</sup> the occasional challenges to admissibility were consist-

---

3. Kushner & Nisselson, Problems in the Management of Courts in California, Report to Assembly Comm. on the Judiciary. Supp. to App. to Journal of the Assembly, Reg. Sess. (1969) 12. See Holmes, *Incorrigible Cahan at Age Fifteen—A Proposal for Civilizing Him*, 45 L.A. BAR BULL. 518, 520-22 (1969).

4. For a useful description of § 1538.5, see Woodworth, *Outline of Procedure Upon Motion to Suppress*, 45 CAL. ST. B.J. 218 (1970).

5. 22 Cal. Assembly Interim Comm. Report No. 12 (1965-1967) [hereinafter cited as Assem. Com. Rep.].

6. 44 Cal. 2d 434, 282 P.2d 905 (1955); Barrett, *Exclusion of Evidence Obtained by Illegal Searches—a Comment on People v. Cahan*, 43 CAL. L. REV. 565 (1955).

ently denied.<sup>7</sup> After *Cahan* the procedure for challenge developed along the lines already familiar in federal courts.<sup>8</sup> This procedure, as it became crystallized, is fully described in *People v. Gershenhorn*,<sup>9</sup> wherein a defendant had the following opportunities to challenge evidence: (1) a non-statutory pretrial motion to suppress;<sup>10</sup> (2) if made and overruled at the preliminary examination, a review by a motion under Penal Code § 995;<sup>11</sup> (3) if unsuccessful, an extraordinary writ of prohibition; (4) if unsuccessful, renewal of the motion at trial; (5) if overruled, raising of the point on appeal from a judgment of conviction.<sup>12</sup>

The Assembly Committee noted several glaring weaknesses in this procedure. "One of the major defects in the present law is that it permits, if not encourages, search and seizure issues to be raised during the trial of a criminal case."<sup>13</sup> This broke the continuity of the proceedings and caused the loss of much jury time. Furthermore, Los Angeles District Attorney Evelle J. Younger testified that fully one-eighth of the time spent by his office was taken up by motions to suppress evidence. Last, but not least, it was felt that for reasons of fairness the prosecution should not be precluded from pretrial appellate review.

The committee report recommended that a study be undertaken to determine the feasibility of establishing pretrial procedure concerning the admissibility of evidence in criminal cases. The result was Penal Code § 1538.5.<sup>14</sup>

---

7. *People v. Kelley*, 22 Cal. 2d 169, 137 P.2d 1 (1943); *People v. Gonzalez*, 20 Cal. 2d 165, 124 P.2d 44 (1942); *People v. Mayen*, 188 Cal. 237, 205 P. 435 (1922); *People v. LeDoux*, 155 Cal. 535, 102 P. 517 (1909); *People v. Alden*, 113 Cal. 264, 267, 45 P. 327, 328 (1896) ("Whether or not the record was removed . . . may, perhaps be a question of some consequence to the person who removed it, but is of no consequence in the case at bar; its competency as evidence in the San Francisco court in no way depended upon the means by which it was brought there.").

8. FED. R. CRIM. P. 41(e); Note, *Methods of Challenging Searches and Seizures in California*, 54 CAL. L. REV. 1070 (1966).

9. 225 Cal. App. 2d 122, 37 Cal. Rptr. 176 (1964).

10. *Saidi-Tabatabai v. Superior Court*, 253 Cal. App. 2d 257, 61 Cal. Rptr. 510 (1967).

11. CAL. PEN. CODE § 995 (West 1972).

12. *Saidi-Tabatabai v. Superior Court*, 253 Cal. App. 2d 257, 61 Cal. Rptr. 510 (1967).

13. Assem. Comm. Rep., *supra* note 5, at 18.

14. See App. C, *infra* at 245.

The salient features of the statute are: (1) its status as an exclusive remedy for illegal search and seizure;<sup>15</sup> (2) its limitations on the right to bring the motion;<sup>16</sup> (3) its provision for pretrial appellate review by both defendant and prosecution;<sup>17</sup> (4) its complex procedural rules. Strangely, the provisions which have stimulated the greatest controversy seem to be the least complex.

## II.

### SCOPE

The statute's first paragraph has proved to be a more fruitful source of discord than the other fourteen together. The California Legislature, in circumscribing the reach of the motion, defined its scope in explicit and unambiguous terms. Nevertheless, various arguments are heard for a "broad" or "narrow" application. Not so oddly, only a few key alterations have been wrought by judicial interpretation and gaps in the statute have been filled in neatly by the courts in keeping with the spirit of the legislature's stated intent.

Paragraph (a) begins: "A defendant may move for the return of property or to suppress as evidence any tangible or intangible thing obtained as the result of a search or seizure. . . ." The first area for contention concerns the grounds upon which challenges may be made.

The cases have been emphatic in holding that § 1538.5 is a remedy for fourth amendment violations only.<sup>18</sup> Paragraph (a) continues:

. . . on either of the following grounds: (1) The search or seizure without a warrant was unreasonable. (2) The search or seizure with a warrant was unreasonable because (i) the warrant is insufficient on its face; (ii) the property or evidence obtained is not that described in the warrant; (iii) there was not probable cause for the issuance of the warrant; (iv) the method of execution of the warrant violated federal or state constitutional standards; (v) there was any other violation of federal or state constitutional standards.

The challenged seizure must be one which has been made by government officers or their agents; absent such governmental involvement, there are no fourth amendment standards for a search

---

15. CAL. PEN. CODE § 1538.5(h), (i), (n) (West 1972).

16. *Id.* § 1538.5(i), (j), (o).

17. *Id.* § 1538.5(a).

18. *People v. Warburton*, 7 Cal. App. 3d 815, 86 Cal. Rptr. 894 (1970), *cert. denied*, 400 U.S. 1022 (1971); *People v. Nebiolini*, 2 Cal. App. 3d 872, 83 Cal. Rptr. 272 (1969); *People v. Morrow*, 276 Cal. App. 2d 700, 81 Cal. Rptr. 201 (1969).

and seizure by private citizens, and accordingly, Penal Code § 1538.5 has no applicability.<sup>19</sup>

The fact that a state statute has applied fourth amendment principles to the conduct of private individuals does not alter this general rule. For example, in the leading case of *People v. Superior Court [Smith]*,<sup>20</sup> Smith, the real party in interest, had requested a private detective to place recording equipment in the offices of the company of which he was an officer. The recording devices inadvertently recorded conversations between Smith and other persons who were later summoned before a grand jury investigating possible bribery. There was no evidence that police officers were involved in the taping of the conversations. The tapes were used to refresh the recollection of the witnesses called before the grand jury. At a § 1538.5 suppression hearing, the trial court suppressed the testimony of witnesses whose memories had been refreshed by the tape recordings on the theory that the recordings contained confidential communications within the meaning of Penal Code § 653(j).<sup>21</sup> The California Supreme Court granted a peremptory writ, commanding the superior court to set aside its order. The supreme court held that Smith was not entitled to invoke Penal Code § 1538.5 because the "seizure" of the conversations was not made by a governmental officer or agent.

The leading case confirming the restriction of § 1538.5 to fourth amendment challenges is *People v. Superior Court [Redd]*<sup>22</sup> decided in 1969. The trial court had suppressed statements in a § 1538.5 hearing where the statements were challenged only on the ground that a proper *Miranda* admonition had not been given. In reversing, the court of appeal pointed out that the illegality complained of was a fifth amendment violation and "It is sufficient for present purposes to hold, as we do, that Penal Code section 1538.5 as enacted is limited solely to questions involving searches and seizures and is inapplicable to the resolution of issues arising from challenged confessions or admissions, except those that constitute the fruit of a search and seizure."<sup>23</sup>

---

19. *People v. Superior Court [Smith]*, 70 Cal. 2d 123, 129, 449 P.2d 230, 234, 74 Cal. Rptr. 294, 298 (1969).

20. 70 Cal. 2d 123, 449 P.2d 230, 74 Cal. Rptr. 294 (1969).

21. CAL. PEN. CODE § 653(j) (West 1972).

22. 275 Cal. App. 2d 49, 79 Cal. Rptr. 704 (1969).

23. *Id.* at 52, 79 Cal. Rptr. at 706.

The apparent clarity of the rule is deceiving. In spite of the categorical exclusion in § 1538.5(a) and the leading interpretation of *Redd*, the fifth amendment issues *can* be argued at a § 1538.5 hearing under two different sets of circumstances. First, an alleged fifth amendment violation may be argued where it is the product of prior alleged fourth amendment illegality. For example, where a confession follows an unlawful arrest, and the defendant asserts that the confession was involuntary because of his unlawful arrest, he may urge both issues at a suppression hearing.<sup>24</sup>

Conversely, where a prior fifth amendment violation is alleged, of which a subsequent fourth amendment violation is the fruit, determination of the fifth amendment issue is necessary to resolve the fourth amendment issue. The leading case demonstrating the latter situation is *People v. Superior Court [Mahle]*,<sup>25</sup> in which police officers, arriving at the scene of a stabbing, obtained statements from the defendant without a *Miranda* admonition. The statements led to the seizure of the knife used in the stabbing. The defendant brought a motion to suppress, arguing that the seizure of the knife was the product of his admissions obtained in violation of his fifth amendment rights. Thus, there was a prior fifth amendment illegality and a subsequent dependent fourth amendment issue. The court accepted the defendant's reasoning and held that § 1538.5 was the proper forum to test the validity of the seizure of the knife and the validity of the admission. In fact, the court held that there was a fifth amendment violation but that no fourth amendment violation had occurred.

The court did not find it necessary to adopt an obvious alternative rationale, which, although not disclosed in the opinion, was certainly open to it: that defendant's detention was based on his statements and that seizure of the knife was a fruit of that illegal detention. This contention would have established a prior fourth amendment illegality. Since the court did not require this rationale, it is clear that the presence of a *dependent* fourth amendment issue is sufficient to permit litigation of all other related issues at a § 1538.5 hearing.

*Mahle* was followed in *Clifton v. Superior Court*<sup>26</sup> and is apparently the law. The holding in *Mahle* has a seldom recognized implication. If the defendant's case involves an alleged fifth amendment violation, e.g., an inadequate *Miranda* admonition, and also

---

24. *People v. Johnson*, 70 Cal. 2d 541, 450 P.2d 865, 75 Cal. Rptr. 401, cert. denied, 395 U.S. 969 (1969).

25. 3 Cal. App. 3d 476, 83 Cal. Rptr. 771 (1970).

26. 7 Cal. App. 3d 245, 86 Cal. Rptr. 612 (1970).

evidence which is a product of that violation, then if defendant wishes to suppress the evidence *he must* bring a § 1538.5 motion and litigate both the fifth and fourth amendment issues. If he fails to do so he waives his right to challenge the derivative evidence and is precluded from bringing the motion at trial by § 1538.5(h). This, of course, gives the prosecution the right to join issue on both grounds and to appeal an adverse ruling.<sup>27</sup>

In the former circumstance, where the prior illegality is premised on fourth amendment grounds, another significant problem arises and its resolution also bears directly on the proper forum for determination of the admissibility of the challenged evidence. The problem has centered around two situations, both involving intangible evidence: one, where a confession is obtained during an illegal detention; the other, where a confession follows confrontation of the defendant with illegally seized evidence.

In the leading case of *People v. Johnson*,<sup>28</sup> the California Supreme Court proclaimed that separate tests were to be used in these two situations: "voluntariness" in the former, "causation" in the latter. The court's holding illustrates the proper application of both tests. The defendant had been confronted with his codefendant's confession during a burglary investigation. The codefendant, in turn, had been induced to confess by being shown the burglary loot—a television set—which the court declared to have been seized in violation of the fourth amendment. Rejecting a "voluntariness" criterion, the court held that the unbroken chain of causation tainted both confessions rendering them inadmissible.<sup>29</sup>

In its application of the "causation" test, the court followed the distinction made in *Rogers v. Superior Court*<sup>30</sup> between evidence seized in violation of search and seizure provisions and voluntary statements made during an illegal detention: "The voluntary admission is *not* a necessary product of the illegal detention; the evidence obtained by an illegal search or by a coerced confession is the necessary product of the search or of the coercion."<sup>31</sup> Other cases,

---

27. CAL. PEN. CODE §§ 1238(7), 1538.5(o) (West 1972).

28. 70 Cal. 2d 541, 450 P.2d 865, 75 Cal. Rptr. 401, *cert. denied*, 395 U.S. 969 (1969).

29. *Id.* at 553, 450 P.2d at 873, 75 Cal. Rptr. at 409.

30. 46 Cal. 2d 3, 291 P.2d 929 (1955).

31. *Id.* at 10, 291 P.2d at 933 (emphasis added).

in accord with *Johnson*, stand for the use of the "voluntariness" test where a confession follows an illegal arrest.<sup>32</sup>

The *Johnson* test, however, has not been uniformly applied. Although the "voluntariness" test was followed in *People v. Dominguez*<sup>33</sup> in 1971, the opposite approach had been taken in the case of *People v. Hatcher*<sup>34</sup> in 1969. *Hatcher* involved the admissibility of a confession elicited during the course of an unlawful arrest. With knowledge of the *Johnson* case, the *Hatcher* court nevertheless traced the causal chain from the arrest to the confession, found it unbroken, and held for the defendant.<sup>35</sup>

As can be seen, the *Johnson* case dealt with legal principles only; since it predated §1538.5,<sup>36</sup> the court did not discuss the numerous practical problems which arise when § 1538.5 is used to challenge the admissibility of statements. When entertaining a § 1538.5 motion, a court is confronted with a basic question: what is its function? Should the court determine only the effect of the alleged unlawful detention or arrest, or should the court look to all factors affecting voluntariness? If the latter approach is adopted, is the defendant precluded from raising the voluntariness issue at trial after the § 1538.5 hearing? Perhaps most important, the suppression court is confronted with the conflict in the differing burdens of proof involved in the determination of a confession on voluntariness grounds as opposed to admissibility challenged solely on fourth amendment grounds.

Because of the problems involved, one writer has urged that *both* tests should be used when determining the admissibility of a statement made during the course of an unlawful detention or arrest; the causation test to be used to determine the admissibility of the confession during the course of a § 1538.5 hearing, and thereafter, the defendant to be allowed to relitigate the issue of admissibility at trial where all factors bearing upon the voluntariness of the confession can be litigated.<sup>37</sup>

The difficulty with this approach is that it frustrates the intended objective of § 1538.5, *i.e.*, to streamline the resolution of fourth amendment related issues.<sup>38</sup> As noted in *Clifton v. Superior*

---

32. *People v. Martin*, 240 Cal. App. 2d 653, 657, 49 Cal. Rptr. 888, 891 (1966).

33. 21 Cal. App. 3d 881, 99 Cal. Rptr. 42 (1971).

34. 2 Cal. App. 3d 71, 82 Cal. Rptr. 323 (1969).

35. *Id.* at 77, 82 Cal. Rptr. at 327.

36. 70 Cal. 2d at 544, 450 P.2d at 868, 75 Cal. Rptr. at 404.

37. Leedy, *Suppression of Statements of a Defendant in Criminal Cases*, San Diego Daily Transcript, June 26, 1972, at 1, col. 4.

38. Assem. Comm. Rep., *supra* note 5.



*Court*<sup>39</sup> and *People v. Superior Court [Mahle]*,<sup>40</sup> § 1538.5 has been used to determine fifth amendment issues where a confession or admission results in the subsequent seizure of evidence. Thus, the concept of using a § 1538.5 hearing to resolve fifth amendment issues is not unique, but the troublesome question which remains relates to the differing burdens of proof.

It has been held that a confession or admission is not admissible in evidence until its voluntariness is established beyond a reasonable doubt,<sup>41</sup> whereas the burden of proof at a § 1538.5 hearing is "preponderance of the evidence."<sup>42</sup> However, it should be noted that the United States Supreme Court, in its most recent term, decided that the admissibility of a confession challenged on fifth amendment grounds can constitutionally be determined by a preponderance of the evidence.<sup>43</sup> Thus the validity of the "reasonable doubt" standard as applied to admissibility of confessions in California is seriously in question.

The California Supreme Court has recently recognized that not only can statements be suppressed pursuant to § 1538.5, but also the testimony of prospective witnesses at trial can be suppressed where the police have discovered the identity of such witnesses as the direct result of a fourth amendment violation.<sup>44</sup> Closely connected to the concept of suppression of a witness is suppression of a witness's observations. In *Kirby v. Superior Court*,<sup>45</sup> a police officer, without probable cause, opened the doors to a van truck and observed sexual conduct in violation of Penal Code § 288(a).<sup>46</sup> The court of appeal held that the observations of the officer should be suppressed and that § 1538.5 was the proper vehicle for suppression.

With regard to allegedly obscene material, § 1538.5 provides a constitutionally permissible vehicle to test the validity of the seiz-

---

39. 7 Cal. App. 3d 245, 86 Cal. Rptr. 612 (1970).

40. 3 Cal. App. 3d 476, 83 Cal. Rptr. 771 (1970).

41. *People v. Chavarria*, 276 Cal. App. 2d 66, 80 Cal. Rptr. 600 (1969); *People v. Stroud*, 273 Cal. App. 2d 670, 78 Cal. Rptr. 270 (1969).

42. *People v. Superior Court [Bowman]*, 18 Cal. App. 3d 316, 95 Cal. Rptr. 757 (1971).

43. *Lego v. Twomey*, 404 U.S. 477 (1972).

44. *Lockridge v. Superior Court*, 3 Cal. 3d 166, 474 P.2d 683, 89 Cal. Rptr. 731 (1970), *cert. denied*, 402 U.S. 910 (1971).

45. 8 Cal. App. 3d 591, 87 Cal. Rptr. 577 (1970).

46. CAL. PEN. CODE § 288 (a) (West 1972).

ure of such material.<sup>47</sup> While federal authorities are in considerable conflict, California cases are uniform in holding that there is no constitutional requirement for a pre-warrant adversary hearing; a § 1538.5 hearing to determine the lawfulness of the seizure of obscene material is sufficiently speedy to meet due process requirements.<sup>48</sup> California cases also hold that there is no constitutional necessity for an *ex parte* judicial viewing of allegedly obscene material prior to the issuance of a search warrant.<sup>49</sup>

§ 1538.5(n) provides:

Nothing contained in this section shall prohibit a person from making a motion, otherwise permitted by law, to return property, brought on the ground that the property obtained is protected by the free speech and press provisions of the Federal and State Constitutions. . . .

While the import of this subdivision has not been analyzed in case law, it seems more probable that this language was intended by the drafters of Penal Code § 1538.5 to preserve the constitutionality of the section in the event that future case law would determine that § 1538.5 was not a sufficiently speedy remedy for the determination of the obscenity issue, rather than as a grant of authority to litigate the lawfulness of seized obscene materials.

Evidence seized pursuant to a search warrant can be suppressed at a § 1538.5 hearing.<sup>50</sup> While there is clear statutory authority for the proposition that a search warrant can be attacked for defects appearing on its face, there has been considerable confusion as to whether a defendant could controvert the truthfulness of allegations contained in the affidavit.<sup>51</sup> The conflict was resolved for

---

47. *People v. Sarnblad*, 26 Cal. App. 2d 801, 103 Cal. Rptr. 211 (1972); *Monica Theater v. Municipal Court*, 9 Cal. App. 3d 1, 8 Cal. Rptr. 71 (1970); *People v. de Renzy*, 275 Cal. App. 2d 380, 79 Cal. Rptr. 777 (1969).

48. *People v. Sarnblad*, 26 Cal. App. 2d 801, 103 Cal. Rptr. 211 (1972); *Monica Theater v. Municipal Court*, 9 Cal. App. 3d 1, 8 Cal. Rptr. 71 (1970). For an excellent discussion of both the state and federal law concerning the seizure of allegedly obscene materials, see Hirsch & Ryan, *I Know It When I Seize It; Selected Problems in Obscenity*, 4 LOYOLA L. REV. 9 (1971).

49. *Monica Theater v. Municipal Court*, 9 Cal. App. 3d 1, 8 Cal. Rptr. 71 (1970); *People v. de Renzy*, 275 Cal. App. 2d 380, 79 Cal. Rptr. 777 (1969).

50. CAL. PEN. CODE § 1538.5(a) (2) (West 1972).

51. *Rugendorf v. United States*, 376 U.S. 528, 532 (1964); *People v. Christian*, 27 Cal. App. 3d 554, 103 Cal. Rptr. 740 (1972); *Monica Theater v. Municipal Court*, 9 Cal. App. 3d 1, 8 Cal. Rptr. 71 (1970); cf. *People v. Buchanan*, 26 Cal. App. 3d 274, 103 Cal. Rptr. 66 (1972); Kipperman, *Inaccurate Search Warrant Affidavits as a Ground for Suppressing Evidence*, 84 HARV. L. REV. 825 (1970); Mascolo, *Impeaching the Credibility of Affidavits for Search Warrants: Piercing the Presumption of Validity*, 44 CONN. B.J. 9 (1970); Note, *Testing the Factual Basis for a Search Warrant*, 67 COLUM. L. REV. 1529 (1967); Note, *Defendant's Right to Controvert a Warrant Valid on its Face*, 34 FORDHAM L. REV. 740 (1966).

California in the recent case of *Theodor v. Superior Court*,<sup>52</sup> in which the California Supreme Court held that a defendant can traverse a search warrant in either the municipal court or the superior court under the aegis of Penal Code § 1538.5.

The supreme court noted at the outset that misstatements contained in an affidavit generally fall into three categories: reasonable errors made in good faith, negligent mistakes, and intentional falsehoods. The court held that a defendant may challenge the factual veracity of an affidavit only if (1) there is a factual misstatement, and (2) the affiant was unreasonable in believing the information. Moreover, the court was careful to point out that the presence in the affidavit of inaccurate allegations resulting from unreasonable activity does not automatically vitiate the warrant. It requires only that such information be deleted and the warrant's validity be tested by the accurate information remaining.

We do not hold that the presence in an affidavit of inaccurate facts caused by unreasonable police activity automatically vitiates the warrant. We require only that such information be deleted and the warrant's validity be tested by the remaining accurate information. The warrant will not be quashed if that remaining information is sufficient, under settled standards, to constitute probable cause for the search.<sup>53</sup>

### III.

#### PROCEDURE AT HEARING

##### *Felony*

A defendant in a felony case has the opportunity to bring at least two motions to suppress. The first motion to suppress may be made in a municipal or justice court at the preliminary hearing,<sup>54</sup> and a second hearing may be had in the superior court.<sup>55</sup> As a matter of practice, a suppression hearing in the municipal court is usually conducted simultaneously with the preliminary hearing. The magistrate rules upon the motion to suppress at the

52. 8 Cal. 3d 77, 501 P.2d 234, 104 Cal. Rptr. 226 (1972).

53. *Id.* at 101 n.14, 501 P.2d at 251 n.14, 104 Cal. Rptr. at 243 n.14. The *Theodor* opinion, handed down September 28, 1972, was modified November 16, 1972, and it is the modified opinion which appears in the reporter. The original opinion, unmodified, is found in the advance sheets at 8 Cal. 3d 77. The modified opinion is found in the advance sheets at 8 Cal. 3d 348a.

54. CAL. PEN. CODE § 1538.5(f) (West 1972).

55. *Id.* § 1538.5(i).

conclusion of evidence presented on that issue and on the issue of probable cause for commitment. Occasionally, however, it is preferable to conduct the suppression hearing immediately preceding the preliminary hearing in order to conserve court time. The decision as to the precise time that the suppression issue should be heard depends upon the complexity of the case. In cases where the predominant issue is the seizure of evidence and the remaining issues involve relatively little extra testimony, court time is economized by conducting the suppression hearing simultaneously with the preliminary examination. However, where there are numerous issues which can be reached only after a determination of the search and seizure issue, then most courts prefer to hear the suppression issue prior to the preliminary examination, on the theory that a finding of illegality as to the seizure may obviate the need to take testimony on the remaining issues.

If the motion to suppress is granted in the municipal court and the defendant is not held to answer, the People may file a new complaint or seek an indictment, and the ruling in the prior hearing is not binding in any subsequent proceedings.<sup>56</sup> If, however, the § 1538.5 motion is granted in whole or in part at the preliminary hearing, but the defendant is held to answer, the People *must*, within ten days after the preliminary hearing, request a special hearing in the superior court. If this is not done, the ruling of the magistrate is binding at all future stages including any hearings in the superior court.<sup>57</sup>

Where evidence is seized pursuant to a search warrant, there are two occasions in the municipal court where the defendant might wish to bring his suppression motion. The defendant may wish to challenge the sufficiency of the search warrant before the magistrate who issued it,<sup>58</sup> or he may wish to challenge the search warrant at the preliminary hearing.<sup>59</sup> He cannot have both hearings; the general rule is that a defendant is entitled to one and only one suppression hearing in the municipal court either before the issuing magistrate or at the preliminary hearing. If the seizure is challenged before the issuing magistrate, that magistrate's finding is binding upon the magistrate hearing the preliminary examination.<sup>60</sup> The defendant can, of course, bring a *de novo* statutory

---

56. *Id.* § 1538.5(j).

57. *Id.*

58. *Theodor v. Superior Court*, 8 Cal. 3d 77, 501 P.2d 234, 104 Cal. Rptr. 226 (1972); CAL. PEN. CODE § 1538.5(b) (West 1972).

59. CAL. PEN. CODE § 1538.5(f) (West 1972).

60. *People v. Sanchez*, 24 Cal. App. 3d 664, 101 Cal. Rptr. 193 (1972).

motion to suppress in the superior court.<sup>61</sup>

### *Special Hearing In The Superior Court*

A defendant has the right to initiate or renew a § 1538.5 motion in the superior court after having given at least ten days notice to the People, unless the prosecution is willing to waive a portion of this time.<sup>62</sup> *People v. Berumen*<sup>63</sup> upheld the ruling of the trial court which declined to hear a § 1538.5 motion because no ten day notice had been given and there was no waiver by the prosecution.

A § 1538.5 hearing in the superior court is de novo on the basis of evidence presented at that suppression hearing, even though there may have been a prior suppression hearing in the municipal court.<sup>64</sup> There are two caveats to this general rule. First, as was previously noted, if a statutory motion to suppress is granted in whole or in part in the municipal court at the preliminary hearing, but the defendant is still held to answer, the People must, within ten days, request a special hearing in the superior court, or else the ruling of the magistrate is binding thereafter. Second, the function of the trial court during a statutory motion to suppress in the superior court is to decide disputed questions of fact, but where the facts bearing on the legality of the search are undisputed, the issue of fourth amendment legality is then a question of law.<sup>65</sup>

Numerous cases have permitted the use of the preliminary transcript as the basis for the evidentiary hearing in the superior court.<sup>66</sup> Use of the preliminary hearing transcript, however, is subject to the same evidentiary rules as any prior recorded testimony.<sup>67</sup> Therefore, if any party objects to its use, the transcript or any portion thereof cannot be used absent unavailability of

---

61. *Id.*; CAL. PEN. CODE § 1538.5(i) (West 1972).

62. CAL. PEN. CODE § 1538.5(i) (West 1972).

63. 1 Cal. App. 3d 471, 81 Cal. Rptr. 757 (1969).

64. *People v. Superior Court [Mahle]*, 3 Cal. App. 3d 476, 83 Cal. Rptr. 771 (1970); CAL. PEN. CODE § 1538.5(i) (West 1972).

65. *People v. Medina*, 26 Cal. App. 3d 809, 103 Cal. Rptr. 337 (1972); *People v. Superior Court [Mahle]*, 3 Cal. App. 3d 476, 83 Cal. Rptr. 771 (1970).

66. *See, e.g., People v. Cagle*, 21 Cal. App. 3d 57, 98 Cal. Rptr. 348 (1971).

67. *Hewitt v. Superior Court*, 5 Cal. App. 3d 923, 927-28, 85 Cal. Rptr. 493, 495 (1970).

witnesses. If the parties intend to use the preliminary hearing transcript in the superior court, there should be a formal stipulation to that effect on the record.<sup>68</sup> There is authority, however, for the proposition that the use of the preliminary hearing transcript, without objection and even without stipulation, is not error.<sup>69</sup>

It is not required that the evidence sought to be suppressed be physically present and introduced at this special hearing. A testimonial description will suffice.<sup>70</sup> However, a defendant must specify in his motion what items he desires to have suppressed, though it is permissible to specify all items seized during a particularly described search.<sup>71</sup> Also, in a strongly worded opinion the court in *People v. Cagle*<sup>72</sup> emphasized the necessity for an accurate description in the record of those items sought to be suppressed. The *Cagle* case is the most recent expression of the necessity for spelling out in the record the grounds sought for suppression. A general objection that the evidence was seized in violation of the fourth amendment does not suffice.<sup>73</sup>

It is now well established that a defendant cannot raise on appeal a ground for suppression when that ground was not urged at the motion to suppress.<sup>74</sup> In *Mesaris v. Superior Court*,<sup>75</sup> the court of appeal declined to issue a writ of mandate on the grounds that it lacked a transcript of the proceedings in the superior court, even though the transcript of the preliminary hearing had been lodged in the appellate court. The result of this rule is that not only the evidence but the argument must be transcribed if the ruling is to be reviewed by the court of appeal. (For a more detailed discussion of this issue, see *The Record On Review, infra*.)

### *Misdemeanor*

Penal Code § 1538.5 applies to suppression of evidence in misdemeanor cases as well as in felony cases.<sup>76</sup> The motion to suppress must be made prior to trial in the municipal court but there is no ten day notice requirement such as is specified for special hearings

---

68. *People v. Cagle*, 21 Cal. App. 3d 57, 60, 98 Cal. Rptr. 348, 350 (1971).

69. *People v. Locke*, 274 Cal. App. 2d 541, 79 Cal. Rptr. 367 (1969).

70. *People v. O'Brien*, 71 Cal. 2d 394, 456 P.2d 969, 79 Cal. Rptr. 313 (1969).

71. *Id.*

72. 21 Cal. App. 3d 57, 98 Cal. Rptr. 348 (1971).

73. *Id.* at 61, 98 Cal. Rptr. at 350.

74. *People v. Knifong*, 23 Cal. App. 3d 154, 100 Cal. Rptr. 92 (1972); *People v. Wolder*, 4 Cal. App. 3d 984, 84 Cal. Rptr. 788 (1970).

75. 4 Cal. App. 3d 976, 85 Cal. Rptr. 124 (1970).

76. CAL. PEN. CODE § 1538.5(g) (West 1972).

in the superior court in felony cases.<sup>77</sup> If the property or evidence to be suppressed relates to a misdemeanor filed together with a felony, the procedures provided for suppression of evidence in felony cases is to be followed.<sup>78</sup>

#### *Burden Of Proof And Burden Of Going Forward*

The burden of producing evidence at a statutory motion to suppress where there is a warrantless seizure presents a unique problem. The burden of justifying an arrest, search or seizure rests upon the prosecution, whereas in most cases the moving party in a motion to suppress is the defendant. In *People v. Carson*,<sup>79</sup> neither the prosecution nor the defense presented any evidence either by way of testimony or by use of the preliminary hearing transcript at the § 1538.5 hearing. The prosecution contended that the burden of going forward with some evidence in support of the motion was on the defendant. The trial court disagreed, and the motion was granted. On appeal, the order of dismissal was reversed. The court of appeal held that even with a warrantless search, the burden of going forward with evidence to establish a prima facie case of fourth amendment illegality was on the defendant. Absent any evidence before the court, the defendant was not entitled to have his motion to suppress granted. As a practical matter, evidence by way of testimony or stipulation that a particular search or seizure was made without a warrant shifts the burden of going forward to the prosecution and the dilemma faced by the defendant in the *Carson* case is obviated.

Where a defendant seeks to challenge a search made pursuant to a search warrant, and the allegations in the affidavit are not at issue, the defense has the burden of establishing a prima facie case of illegality.<sup>80</sup> However, where the challenge is to the accuracy of the allegations in the affidavit, the issues are more complex. There are two issues to resolve: (1) Does the affidavit contain factual misstatements? (2) If so, did the affiant nevertheless act reasonably in believing the facts to be true?<sup>81</sup> The California Su-

---

77. *Id.*

78. *Id.*

79. 4 Cal. App. 3d 782, 84 Cal. Rptr. 699 (1970).

80. *Id.* at 786-87, 84 Cal. Rptr. at 703.

81. *Theodor v. Superior Court*, 8 Cal. 3d 77, 101, 501 P.2d 234, 104 Cal. Rptr. 226 (1972).

preme Court recently held that the defendant has the initial burden of demonstrating the inaccuracy of the allegations in the affidavit, the prosecution having already sustained its initial burden by virtue of the affidavit itself. Once it is shown that the affidavit contains inaccurate statements of fact, the burden shifts to the prosecution to demonstrate that the affiant's belief in the truth of the erroneous statements was nonetheless reasonable under the totality of the circumstances.<sup>82</sup> However, the California Supreme Court has emphasized that the defendant does not carry the initial burden by making a bald conclusionary statement that the allegations in the affidavit are inaccurate on the hope that some inaccuracy or falsehood may emerge.<sup>83</sup>

Turning from the burden of going forward to the burden of proof, the quantum of proof at a Penal Code § 1538.5 hearing is "preponderance of the evidence," not "beyond a reasonable doubt," because determination of fourth amendment issues is a "preliminary fact."<sup>84</sup> Penal Code § 1538.5 does not change the burden of proof from that which existed prior to the enactment of that section.<sup>85</sup>

#### *Special Problems Relating To Rulings On The Motion*

The mode and manner of appellate review following the granting or denial of a motion to suppress is discussed later under the heading "Appellate Review." However, several troublesome problems remain regarding the effect of rulings on a motion to suppress. Special difficulties have arisen where the superior court entertains both a motion to suppress pursuant to Penal Code § 1538.5 and a motion to set aside the information or indictment pursuant to Penal Code § 995.<sup>86</sup>

In a motion to set aside an information under § 995, the superior court determination is limited to evidence in the transcript from the preliminary hearing viewed in a light most favorable to the prosecution. A § 995 motion can be granted on search and seizure grounds only where the evidence shows as a matter of law that the search and seizure was unlawful. All factual inferences must be drawn in favor of the order of commitment.<sup>87</sup>

---

82. *Id.* at 103, 501 P.2d at 248, 104 Cal. Rptr. at 240.

83. *Id.*

84. *People v. Orr*, 26 Cal. App. 3d 849, 103 Cal. Rptr. 266 (1972); *People v. Superior Court [Bowman]*, 18 Cal. App. 3d 316, 95 Cal. Rptr. 757 (1971).

85. CAL. PEN. CODE § 1538.5(n) (West 1972).

86. *Id.* § 995.

87. *People v. Superior Court [Kusano]*, 276 Cal. App. 2d 581, 81 Cal. Rptr. 42 (1969).



Where a § 995 motion and a § 1538.5 motion are heard together, the manner in which both motions are disposed of becomes very important. If both motions are entertained together and the superior court is disposed to suppress certain evidence, the proper procedure is to postpone determination of the motion to set aside the information until the People have exhausted or waived their rights to appellate review of the suppression order.<sup>88</sup> This procedure is necessary since the prosecution can appeal the granting of the § 995 motion, but is precluded from seeking any appellate review of the order granting a § 1538.5 motion; an order granting a § 1538.5 motion is itself not subject to appeal by the prosecution. Only when the case is dismissed pursuant to Penal Code § 1385 can the prosecution appeal the merits of the § 1538.5 ruling.<sup>89</sup>

Absent a dismissal under § 1385, the only available remedy to review the § 1538.5 ruling is an extraordinary writ. However, if the trial court has already dismissed the case under § 995, the remedy of extraordinary writ is no longer possible. Consequently, several cases recommend that if a § 1538.5 motion is granted, the court should hold in abeyance a ruling on the motion to set aside the information. If the court does undertake to dismiss the information contemporaneously with the granting of a motion to suppress, these cases hold that the dismissal should take place pursuant to Penal Code § 1385, rather than § 995. This procedure permits an orderly review on appeal.<sup>90</sup> One court has gone as far as to hold that a trial court hearing a motion to suppress and simultaneously a motion to dismiss lacks jurisdiction to proceed on the § 995 motion, where it grants the § 1538.5 motion.<sup>91</sup>

A particularly troublesome practical problem arises where a motion to suppress is brought simultaneously with a § 995 motion, and, because of a defective record, the trial court feels compelled to grant the § 995 motion but, because of additional evidence correcting defects in the record, the court is disposed to uphold the

---

88. *People v. Superior Court [MacLachlin]*, 271 Cal. App. 2d 338, 76 Cal. Rptr. 712 (1969).

89. *Id.*; CAL. PEN. CODE § 1538.5(o) (West 1972).

90. *People v. Minervini*, 20 Cal. App. 3d 832, 98 Cal. Rptr. 107 (1972); *People v. Superior Court [Kusano]*, 276 Cal. App. 2d 581, 81 Cal. Rptr. 42 (1969).

91. *People v. Superior Court [MacLachlin]*, 271 Cal. App. 2d 338, 76 Cal. Rptr. 712 (1969).

search and seizure and deny the motion to suppress. For example, assume evidence before the magistrate at the preliminary hearing shows that evidence was seized pursuant to a valid search warrant, but the record is silent with regard to the knock and notice requirements of Penal Code § 1531.<sup>92</sup> Then, at the motion to suppress in superior court, the prosecution produces additional evidence establishing that the requirements of § 1531 were met during the execution of the search warrant. Should the trial court grant the § 995 motion because of the defective record from the preliminary hearing while the court is aware of other evidence showing the entry to be lawful? Neither § 1538.5 nor case law has focused directly on the problem.

Common sense would dictate that the granting of a § 995 motion under such circumstances would be a useless, wasteful act inasmuch as the function of the § 995 motion is to prevent only unfounded charges from going to trial.<sup>93</sup>

The solution to this dilemma is for the trial court to refuse to hear the § 995 motion. While it is true that a § 995 motion *erroneously* denied is reversible error, it is also true that the § 995 motion is discretionary.<sup>94</sup> While a court hearing a § 995 motion cannot go beyond the record of evidence presented before the preliminary hearing magistrate or the grand jury, a court can exercise its discretion in refusing to hear a § 995 motion where the court is aware of legally competent evidence establishing probable cause to believe the defendant has committed the crime with which he is charged.<sup>95</sup> In *People v. Anderson*<sup>96</sup> defendant was indicted for murder. The only evidence connecting defendant with the crime presented to the grand jury was statements in violation of *Escobedo v. Illinois*.<sup>97</sup> Defendant was convicted and his conviction was reversed. Prior to his retrial, defendant moved to withdraw his not guilty plea for the purpose of making a § 995 motion. The trial court denied the motion to withdraw the plea, thus preventing defendant from bringing his § 995 motion. The supreme court upheld the trial court's action:

In this situation the trial judge was called upon to determine whether to set aside defendant's plea, based on a motion which was urged in relation to a *second* trial. If we were to hold that the [trial] judge could not consider evidence properly admitted at the

---

92. CAL. PEN. CODE § 1531 (West 1972).

93. *People v. McBride*, 268 Cal. App. 2d 824, 74 Cal. Rptr. 375 (1968).

94. *People v. Sigal*, 249 Cal. App. 2d 299, 57 Cal. Rptr. 541 (1967).

95. *Id.*

96. 70 Cal. 2d 15, 447 P.2d 942, 73 Cal. Rptr. 550 (1968).

97. 378 U.S. 478 (1964).

first trial, we would do no more than compel the People to perform the needless formality of obtaining a second indictment. We therefore hold that the trial court's denial of defendant's motion to set aside a plea prior to a second trial does not constitute an abuse of discretion when, as here, the first trial reveals ample legally competent evidence on which a valid re-indictment can be obtained.<sup>98</sup>

Reasoning by analogy, a trial court called upon to consider a § 995 motion simultaneously with a § 1538.5 motion, where the record is defective as to fourth amendment issues in the § 995 motion, but which deficiencies are corrected with additional testimony at the § 1538.5 motion, is justified in exercising its discretion in refusing to hear the § 995 motion and denying the § 1538.5 motion.

A fair amount of litigation has developed regarding the defendant's right to renew a suppression motion after it has once been denied. The general rule in misdemeanor cases is that a defendant *cannot* bring a second motion to suppress.<sup>99</sup> In felony cases, there can be no second motion to suppress in the superior court either prior to trial<sup>100</sup> or at the trial itself.<sup>101</sup> However, where the suppression court has heard the motion, that court can "reconsider" its own motion within thirty days—that is, until the original order has become final.<sup>102</sup> Thereafter, there can be no renewal of a § 1538.5 motion in the superior court unless there has been an intervening change in the law or the defendant has discovered new evidence not obtainable at his first motion.<sup>103</sup>

98. 70 Cal. 2d at 23, 447 P.2d at 946, 73 Cal. Rptr. at 554.

99. *People v. Sanchez*, 24 Cal. App. 3d 664, 101 Cal. Rptr. 193 (1972).

100. *People v. Superior Court [Green]*, 10 Cal. App. 3d 477, 89 Cal. Rptr. 223 (1970).

101. *People v. Harrington*, 2 Cal. 3d 991, 471 P.2d 961, 88 Cal. Rptr. 161 (1970). While suppressed evidence is inadmissible at trial, it is admissible at a parole revocation hearing, *In re Martinez*, 1 Cal. 3d 641, 463 P.2d 734, 83 Cal. Rptr. 382 (1970), and at a probation revocation hearing, *People v. Hayko*, 7 Cal. App. 3d 604, 86 Cal. Rptr. 726 (1970).

102. *People v. Krivda*, 5 Cal. 3d 357, 486 P.2d 1262, 96 Cal. Rptr. 62, *remanded on other grounds sub nom. California v. Krivda*, 93 S. Ct. 32 (1972), *aff'd sub nom. People v. Krivda*, 8 Cal. 3d 623, 105 Cal. Rptr. 521, — P.2d — (1973); *People v. Leighter*, 15 Cal. App. 3d 389, 93 Cal. Rptr. 136 (1971).

103. *People v. Superior Court [Edmonds]*, 4 Cal. 3d 605, 483 P.2d 1202, 94 Cal. Rptr. 250 (1970). As originally enacted, § 1538.5(h) provided: "If prior to the trial of the felony or misdemeanor, opportunity for this motion did not exist, or the defendant was not aware of the grounds for the motion, the defendant shall have the right to make this motion during the course of the trial in the municipal court, justice, or superior court. Furthermore, the court in its discretion, may entertain the motion during the course of the trial." (Emphasis added). *People v. O'Brien*, 71 Cal. 2d

In one unreported decision,<sup>104</sup> it was held that a defendant could not bring a second motion to suppress in the superior court where there had been a mistrial between the first and second motions. The defendant, at his second motion to suppress, attempted to raise additional issues, but the trial court refused to allow relitigation of any fourth amendment issue. The court of appeal affirmed the ruling of the trial court, holding (1) that the additional issues sought to be relitigated at the second motion to suppress were known or could have been known at the first motion to suppress and (2) there was no intervening change of law or change of circumstances which would permit a renewed motion.

Where a defendant in a felony case has not brought a motion to suppress prior to trial, he can bring that motion at the time of the trial itself, *only* if grounds for the motion did not exist or the defendant was not aware of the grounds prior to trial.<sup>105</sup> Furthermore, the requisite ten day notice to the prosecution is still required, and a trial court's refusal to entertain a suppression motion at trial on the ground that the prosecution has not received its statutory ten day notice, will be upheld on appeal.<sup>106</sup>

#### IV.

##### APPELLATE REVIEW

##### *Misdemeanors*<sup>107</sup>

Where a defendant in a misdemeanor case has made his motion to suppress in a municipal or justice court prior to trial, both the People and the defendant have the right to appeal an adverse decision of that court to the superior court appellate department.<sup>108</sup>

---

394, 456 P.2d 969, 79 Cal. Rptr. 313 (1969), held that subdivision (h), and particularly the last sentence, did not authorize the making of a second motion to suppress in the superior court. The supreme court contrasted subdivision (h) with subdivision (i) which expressly grants a defendant the right to "renew or make" the motion at a special hearing even though he may have already so moved at his preliminary examination. By omitting the word "renew" in subdivision (h), the supreme court concluded, the legislature intended to limit the operation of that provision to instances in which the motion is made or entertained for the first time at trial. During the 1970 legislative term, the legislature, as if to ratify the reasoning of the *O'Brien* court, moved to eliminate the ambiguity caused by the last sentence of § 1538.5(h) by deleting that sentence from the subdivision.

104. *People v. Donnelly*, 4 Crim. 5067 (4th Dist. Ct. App., Oct. 19, 1972).

105. *People v. O'Brien*, 71 Cal. 2d 394, 456 P.2d 969, 79 Cal. Rptr. 313 (1969).

106. *People v. Berumen*, 1 Cal. App. 3d 471, 81 Cal. Rptr. 757 (1970).

107. See App. B *infra* at 244.

108. CAL. PEN. CODE § 1538.5(j) (West 1972).

There is a significant difference in appellate procedure between misdemeanors and felonies after denial of a motion to suppress. In felony cases, after denial of the motion heard prior to trial, appellate review is by way of extraordinary writ; in misdemeanor cases, the defendant whose motion is denied should appeal rather than seek an extraordinary writ.<sup>109</sup>

Of particular importance is Penal Code § 1510,<sup>110</sup> added to the Penal Code in 1971, which provides that a defendant can appeal an adverse ruling at a suppression hearing in a misdemeanor case only if the initial motion to suppress was made by the defendant in the trial court not later than forty-five days following defendant's arraignment on the complaint, unless within this time limit the defendant was unaware of the issue or had no opportunity to raise it. Penal Code § 1510 was the legislative answer to the problem of trial delay caused by the late setting or excessive continuances of pretrial motions.

If a motion to suppress is granted in a misdemeanor case, the People have the right of appeal as well.<sup>111</sup> This is so even though there is no express provision in Penal Code § 1466<sup>112</sup> (the People's appeal section). Any assumed conflict is resolved in favor of a Peo-

---

109. *Id.* § 1538.5(o), (j) (West 1972). The right of *appeal* from a non-final order as provided for in Penal Code § 1538.5(j) is virtually unprecedented in criminal law. The choice of providing appeal rather than extraordinary writ relief was not accidental. As is stated in *Monica Theater v. Municipal Court*, 9 Cal. App. 3d 1, 12, 88 Cal. Rptr. 71, 78 (1970): "No doubt the variance in review remedies is based upon the assumption that the time schedule leading to a decision (by way of appeal) in the appellate department of a superior court is more rapid than that in a Court of Appeal (where mandate and prohibition provide a speedier means to a prompt decision) and upon a desire that the review in misdemeanor cases at the superior court level be in the appellate department of that court." Furthermore, the *Monica* court theorized in footnote 12: "One forceful reason for not doing so is that there should be an end to reviews. A defendant ordinarily should not get a fourth judicial consideration by being able to appeal to the Court of Appeal from an adverse decision on an extraordinary writ proceeding before a superior court judge. . . ." This feeling that appeal, rather than review by writ, is speedier and precludes a fourth review by appeal from the denial of an extraordinary writ in a superior court, accurately states the intention of the drafters of Penal Code § 1538.5 as confirmed by conversations with one of the principal drafters, Harry Sondheim, a deputy in the Los Angeles District Attorney's Office.

110. CAL. PEN. CODE § 1510 (West 1972).

111. *Id.* § 1538.5(j).

112. *Id.* § 1466.

ple's appeal under Penal Code § 1538.5(j), inasmuch as that section was enacted long after Penal Code § 1466.<sup>113</sup>

#### *Felony—Review By Defendant*<sup>114</sup>

Under § 1538.5(i), a felony defendant may seek pretrial appellate review of an adverse decision on a motion to suppress by means of extraordinary writ, on condition that the writ is filed within thirty days after the denial of the motion at the special hearing. The thirty day period allowed under § 1538.5(i) commences when the hearing judge orally denies the motion, not when the denial is entered into the minutes. Observance of this thirty day period is jurisdictional.<sup>115</sup>

In a further restriction, Penal Code § 1510 provides that the defendant can have pretrial appellate review in a felony case only if his motion in the superior court was brought within sixty days following his arraignment on the information or indictment, except where the defendant was unaware of the issues or had no opportunity to raise them earlier.

A defendant may seek further review of his fourth amendment issues upon appeal from a conviction, notwithstanding the fact that such judgment of conviction is predicated upon a plea of guilty, provided that at some stage of the proceedings prior to the conviction, he has moved for the return of property or suppression of the evidence.<sup>116</sup>

A defendant who pleads *nolo contendere* after the denial of a § 1538.5 motion also has the right of appeal.<sup>117</sup> No certificate of probable cause is needed in either case.<sup>118</sup>

If, after the denial of a § 1538.5 motion, the defendant goes to trial and is convicted, he can appeal the merits of the adverse ruling made at the § 1538.5 hearing without the necessity of objecting to the evidence on fourth amendment grounds during the course of the trial itself.<sup>119</sup>

Does a defendant in a felony case preserve his fourth amendment issue for appeal if such issue is raised only by a statutory motion

---

113. *Adams v. Superior Court*, 8 Cal. App. 3d 569, 87 Cal. Rptr. 667 (1970).

114. *See App. A infra* at 243.

115. *Gomes v. Superior Court*, 272 Cal. App. 2d 702, 77 Cal. Rptr. 539 (1969).

116. CAL. PEN. CODE § 1538.5(m) (West 1972).

117. *People v. Warburton*, 7 Cal. App. 3d 815, 86 Cal. Rptr. 894 (1970).

118. *Id.*; *People v. Coyle*, 2 Cal. App. 3d 60, 83 Cal. Rptr. 924 (1970).

119. *People v. Medina*, 26 Cal. App. 3d 809, 815, 103 Cal. Rptr. 337, 341 (1972).

to suppress before a magistrate in the *municipal court*? In *People v. Knifong*,<sup>120</sup> the defendant brought a § 1538.5 motion at the time of his preliminary examination, contending that his rights under Penal Code § 844<sup>121</sup> had been violated. The motion was denied. In the superior court, the defendant brought a new motion to suppress, contending that certain money found on his person was not admissible at trial, but the § 844 issue was not raised. The motion was denied. On appeal from conviction, defendant sought to have the court of appeal reexamine the § 844 issue. The court of appeal recognized that there was some language within § 1538.5(m) which gave support to defendant's contention. The court concluded, however, ". . . we think that the Legislature did not intend that a superior court judgment be open to attack on a ground not urged before the court and on which that court had no opportunity to rule."<sup>122</sup>

An interesting dilemma was resolved in *Cornelius v. Superior Court*.<sup>123</sup> During the course of his first trial, Cornelius made a statutory motion to suppress which was denied. He was acquitted on all counts, save one. The jury could not agree as to this count, and a mistrial was declared. Following the order of mistrial, a second motion to suppress was also denied. The court of appeal noted that the issue of appellate review following a mistrial or the granting of a new trial was a matter of first impression; § 1538.5 did not contemplate either situation. The court then held that the second motion to suppress was properly denied because the latter court was passing upon the same issues that were considered by the court at the first motion to suppress and Cornelius had shown no new changes of circumstances or law entitling him to renew his motion. In regard to the proper procedure for appellate review following a mistrial or the granting of a new trial, the court of appeal recognized the dilemma where there is no appeal prior to the second trial. The court went on to hold, by analogy to subdivision (i) of

---

120. 23 Cal. App. 3d 154, 100 Cal. Rptr. 92 (1972).

121. CAL. PEN. CODE § 844 (West 1972).

122. 23 Cal. App. 3d at 162, 100 Cal. Rptr. at 97. The *Knifong* court also expressed the belief that perhaps a court of appeal could review a statutory suppression ruling made in the municipal court in cases not reaching the superior court, *i.e.*, where the defendant has entered a plea of guilty in the municipal court, or in cases reaching the superior court only for sentence after a guilty plea in a municipal or justice court.

123. 25 Cal. App. 3d 581, 102 Cal. Rptr. 59 (1972).

§ 1538.5, that the proper method of review should be by petition for extraordinary writ filed within thirty days after the order declaring a mistrial or, where a new trial is granted, within thirty days after the order granting the new trial becomes final. The same rule should be applicable to the situation in which a defendant appeals the granting of a new trial on the ground that the issues in such an appeal would be limited to the question of abuse of discretion in granting the new trial.

Though it would appear from a literal reading of Penal Code § 1538.5 that a defendant is entitled to appellate review both by way of extraordinary writ prior to trial and review by way of appeal upon conviction, the general rule affords only one opportunity for appellate review.<sup>124</sup> The supreme court has made clear, however, that the general rule applies only when the sole possible reason for denial of the pretrial extraordinary writ was that the issues were decided on the merits, or it affirmatively appears that the denial was intended to be on the merits.<sup>125</sup> The supreme court recognized that pretrial extraordinary writs are discretionary in nature and are often denied without a review of the merits raised in the petition. Therefore, neither the doctrine of *res judicata* nor law of the case can apply unless it is shown that the merits, in fact, were reviewed by the appellate court considering the petition for the extraordinary writ.

The express language in § 1538.5 notwithstanding, the proper remedy for a defendant upon denial of a § 1538.5 motion pretrial is by way of writ of mandate rather than a writ of prohibition.<sup>126</sup> Undoubtedly, the reason for this rule is that when considering a petition for an extraordinary writ, the court of appeal has before it only the records and transcripts pertaining to the suppression hearing. The appellate court is unaware of any additional evidence of the prosecution which was not considered at the hearing. Therefore, the proper remedy is mandate directing the trial court to set aside its suppression order, rather than prohibition preventing the superior court from proceeding with the trial.<sup>127</sup>

There is a significant omission in § 1538.5 in another specific situation. When a motion to suppress is granted at the preliminary

---

124. *People v. Medina*, 6 Cal. 3d 484, 492 P.2d 686, 99 Cal. Rptr. 630 (1972).

125. *Id.*

126. *Raymond v. Superior Court*, 19 Cal. App. 3d 321, 96 Cal. Rptr. 678 (1971); *Ojeda v. Superior Court*, 12 Cal. App. 3d 909, 91 Cal. Rptr. 145 (1970).

127. *Raymond v. Superior Court*, 19 Cal. App. 3d 321, 96 Cal. Rptr. 678 (1971).



hearing, but the defendant is still held to answer, if the prosecution seeks a relitigation of the previously suppressed evidence it must file a notice of intention in the superior court to have a § 1538.5 hearing within ten days.<sup>128</sup> There is no provision in § 1538.5 for appellate relief for the defendant if the prosecution's motion is granted. This void was filled by the court of appeal in *Nerell v. Superior Court*:<sup>129</sup> "While no express language is contained in § 1538.5, subdivision (j) of the Penal Code authorizing the defendant to seek extraordinary relief following the granting of the People's motion to admit evidence, the fact that the prosecution may seek such relief if its motion is denied supports the implication that the accused also enjoys the same remedy."<sup>130</sup> The *Nerell* court held that where the prosecution's § 1538.5(j) motion is granted, the defendant is entitled to pretrial relief by writ of mandate.

*Felony—Review By The People*<sup>131</sup>

Penal Code § 1538.5(o) provides:

Within 30 days after a defendant's motion is granted at a special hearing in the superior court, the people may file a petition for writ of mandate or prohibition, seeking appellate review of the ruling regarding the search or seizure motion. If the trial of a criminal case is set for a date which is less than 30 days from the granting of a defendant's motion at a special hearing in the superior court, the people, if they have not filed such a petition and wish to preserve their right to file such a petition, shall file in the superior court on or before the trial date or within 10 days after the special hearing, whichever occurs last, a notice of intention to file such a petition and shall serve a copy of the notice upon the defendant.<sup>132</sup>

If the superior court suppresses evidence but does not dismiss the case, the People may seek review of the order of suppression by writ of mandate pursuant to subdivision (o) of § 1538.5. If the court, after making an order of suppression, dismisses the case under Penal Code § 1385,<sup>133</sup> the People may appeal from that order under subdivision (7) of Penal Code § 1238.<sup>134</sup>

---

128. CAL. PEN. CODE § 1538.5(j) (West 1972).

129. 20 Cal. App. 3d 593, 97 Cal. Rptr. 702 (1971).

130. *Id.* at 596, 97 Cal. Rptr. at 704.

131. *See App. A infra* at 243.

132. CAL. PEN. CODE § 1538.5(o) (West 1972).

133. *Id.* § 1385.

134. *Id.* § 1238; *see People v. Superior Court [Kusano]*, 276 Cal. App. 2d 581, 81 Cal. Rptr. 42 (1969).

An often overlooked provision of § 1538.5(j) provides that if the defendant's motion is granted at a pretrial hearing in the superior court, the People, if they have additional evidence relating to the motion which was not presented at the special hearing, shall have the right to show good cause at trial why that evidence was not presented at the special hearing and why the prior ruling at the special hearing should not be binding. This good cause showing at trial is an alternative to appellate review by pretrial writ.

The prosecution in *People v. Superior Court [Palmeri]*<sup>135</sup> was confronted with a novel circumstance. A motion to suppress in the superior court was granted as to a portion of the prosecution's evidence. Several days later, the court, reconsidering its decision, modified its order, denying the motion as to narcotics paraphernalia which had previously been suppressed. Other evidence previously suppressed was not affected by the modification. The People sought an extraordinary writ as to the evidence still suppressed. However, the petition was filed more than thirty days after the original order, although within thirty days of the modification. The court of appeal held that the thirty day period for the filing of the writ by the prosecution started from the date of the original order and not from the date of the modification, at least where the modification was favorable to the People.

If a defendant's motion to suppress is granted and the case is dismissed, § 1538.5(k) provides that the defendant shall be released on his own recognizance pursuant to the provisions of Penal Code § 1318,<sup>136</sup> and shall not be returned to custody unless the proceedings are resumed in the trial court. § 1538.5(k) similarly provides that if the defendant's motion to suppress is granted but the case is not dismissed, and the People file a petition for writ of mandate or prohibition, the defendant shall be released without bail. If he is charged with a capital offense and the proof is evident and the presumption great, then the defendant can be held without bail. If the defendant is charged with a non-capital homicide offense, then the defendant can be required to post bail. The latter provision of subdivision (k) was the legislative answer to the holding in *People v. Superior Court [Mahle]*<sup>137</sup> wherein the defendant, on retrial, was charged with second degree murder. The court of appeal held that release without bail was mandatory under subdivision (k) as it then existed.

---

135. 269 Cal. App. 2d 71, 74 Cal. Rptr. 697 (1969).

136. CAL. PEN. CODE § 1318 (West 1972).

137. 3 Cal. App. 3d 476, 83 Cal. Rptr. 771 (1970).

*The Record On Review*

In 1967, as part of the same legislation which created § 1538.5, the Legislature also amended Penal Code § 1539.<sup>138</sup> Subdivision (a) of that section provides that all testimony must be reported by shorthand reporter. Subdivision (b) provides that upon *written* request of any party, the reporter shall transcribe his notes and prepare copies sufficient for each party to the hearing. The county clerk is required to deliver the original of the transcription to the district attorney and a copy of the transcript to each defendant. This is provided without charge to any of the parties.

An important problem arises as to the mechanics of presenting the proper documents to an appellate court for pretrial review. The weight of authority follows the holding of *Thompson v. Superior Court*<sup>139</sup> wherein the defendant's motion to suppress was presented orally in the superior court. The evidentiary basis was provided by the transcript of the preliminary hearing, although there was no stipulation to that effect. Suppression was denied. The defendant sought mandate in the appellate court. He supplied the preliminary hearing transcript but did not submit the transcription of the oral argument made in the superior court indicating either the specific grounds raised at the suppression hearing or a stipulation that the preliminary hearing transcript was to serve as the basis for the suppression hearing in the superior court. The *Thompson* court held that a defendant must supply to the court of appeal a complete transcript of the hearing in the superior court. Having failed to do this, the writ was denied. The *Thompson* court recognized that there are mechanical difficulties involved and that it might not always be possible for the reporter to have sufficient time to prepare the necessary transcription. In such event, the court of appeal noted that in order to preserve the record for pretrial appellate review, the petitioner at least should have included a copy of the written notice to the reporter as required in § 1539.<sup>140</sup>

*Mesaris v. Superior Court*<sup>141</sup> emphasizes the need for a full transcription of oral arguments as well as evidence taken at the sup-

---

138. CAL. PEN. CODE § 1539 (West 1972).

139. 262 Cal. App. 2d 98, 68 Cal. Rptr. 470 (1968).

140. *Id.* at 104, 68 Cal. Rptr. at 474.

141. 4 Cal. App. 3d 976, 85 Cal. Rptr. 124 (1970).

pression hearing. The *Mesaris* court had before it, on a petition for writ of mandate, a preliminary hearing transcript that lacked a transcript from the suppression hearing held in the superior court. The court of appeal noted that its function was to review only errors preserved for appeal by specific objection and it could not pass upon the legality of rulings made at the § 1538.5 hearing in the superior court because there was no record of what had been urged as error. Accordingly, the writ was denied.

The case of *People v. Pranke*<sup>142</sup> presents a clear illustration of the practical requirement, that, on review of the superior court's suppression order, the court of appeal must have the transcript of the hearing which includes all arguments. In *Pranke*, defendant urged suppression of some of the evidence resulting from an arrest and did not contest the seizure of other evidence obtained by consent. The appellate court, for reasons which become apparent upon a reading of the facts of the case, recognized that the defense attorney's lack of objection to the evidence which had been obtained by consent was dictated by trial strategy. The appellate court therefore held that defendant was precluded from contesting this evidence. The appellate court also pointed out that specific grounds for objection must be presented at the time of the suppression hearing in order to put the opposing party on notice to present all relevant evidence on the issues objected to.

As a practical matter, when a written notice pursuant to Penal Code § 1539 is filed, that notice should also include a request for the transcription not only of evidence, but also of all oral arguments in view of the practice of many reporters of transcribing only evidence and not the argument or objections raised during argument.

One case has declined to follow the line of authority which began with *Thompson*. In *Amacher v. Superior Court*<sup>143</sup> the court of appeal held that a petitioner's duties were discharged by the filing of the preliminary hearing transcript. The record in the *Amacher* case did include minutes from the superior court suppression hearing showing the parties' stipulation that the suppression court could consider the evidence from the preliminary hearing as evidence for the suppression hearing in the superior court. Also there was no transcript of oral argument at the suppression hearing. However, the *Amacher* court did not find this error nor did it discuss the numerous problems related to the lack of such transcript.

---

142. 12 Cal. App. 3d 935, 91 Cal. Rptr. 129 (1970).

143. 1 Cal. App. 3d 150, 81 Cal. Rptr. 558 (1970).

Problems relating to the record are simplified when a defendant seeks appellate review after conviction. A defendant's duties are easily discharged by filing a designation of record on appeal.<sup>144</sup> This should include a short specific description of each document necessary for the appeal, including the preliminary hearing transcript if that was the evidentiary basis used in the suppression court, a transcript of the evidence and oral testimony considered in the superior court, and the minutes and orders prepared at the time of the superior court hearing.

### *Tests On Review*

A court reviewing a ruling made pursuant to § 1538.5, whether pretrial or post-conviction, must view the facts in the light most favorable to the prevailing party.<sup>145</sup> The reviewing court is to use the "substantial evidence test."<sup>146</sup>

## V.

### EVALUATION

Claim and counterclaim have marked the progress of Penal Code § 1538.5 from the time of its introduction in the California Legislature in 1965 as Assembly Bill 1651. Advocates of the proposed legislation noted that pretrial criminal procedure as it existed prior to 1967 produced unnecessary delay, that it operated in a manner to discourage plea negotiations, and that the prosecution was denied the opportunity of appellate review on search and seizure issues.<sup>147</sup> The unhappy situation in California was contrasted with Federal Rule 41(e) which provided for pretrial disposition of search and seizure issues in one hearing.

Advocates of the statutory suppression legislation were enthusiastic in their support. If enacted, the legislation would shorten trials, conserve court time and redress unequal treatment accorded to the prosecution on fourth amendment issues.<sup>148</sup>

---

144. CAL. RULES OF CT., R. 5(a) (West 1972).

145. *People v. Villafuerte*, 275 Cal. App. 2d 531, 80 Cal. Rptr. 279 (1969).

146. *People v. Orr*, 26 Cal. App. 3d 849, 103 Cal. Rptr. 266 (1972); *People v. Medina*, 26 Cal. App. 3d 809, 815, 103 Cal. Rptr. 337, 341 (1972).

147. *Assem. Comm. Rep. supra* note 5.

148. *Id.*

It was thought that trial time would be reduced because it would not be necessary to interrupt the trial and excuse the jury while court and counsel wrestled over time-consuming fourth amendment questions. Ancillary benefits would include the conservation of costly jury time and maintenance of trial continuity.

Overall court time would be conserved for a variety of reasons. Case load would be reduced through more frequent dispositions resulting from plea negotiations. Attorneys for both prosecution and defense could better assess the value of their cases once the uncertainty of the admissibility of evidence was resolved. Court case backlogs would be further reduced because A.B. 1651 would obviate the need to go to trial to preserve fourth amendment issues for appeal. Finally, cases involving illegally seized evidence could be dismissed without trial.

It was also claimed that A.B. 1651 would redress several inequities suffered by the prosecution. The proposed legislation provided for prosecution appeal of adverse rulings on search and seizure issues where none existed before. This would obviously benefit the individual cases where adverse pretrial rulings could be reversed on appeal, but the primary motivation of the prosecuting authorities was not simply the accession to a procedural advantage. Rather, the overriding belief was that the proposed procedure was more likely to achieve the ends of justice. The prosecution wanted the opportunity to develop case law on points not raised by defense-initiated appeals, and thereby bring about a more orderly development of the law.

There is good reason to believe that this last point, prosecution appellate review, was the foremost consideration which motivated the drafting of A.B. 1651.<sup>149</sup>

The bill undeniably held out benefits for the defense. A defendant convicted through the use of illegally seized evidence would not have to languish in jail pending his lengthy post-trial appeal. Although a defendant could petition for a pretrial extraordinary writ prior to 1967, the granting of a hearing on the writ was discretionary; under A.B. 1651 the pretrial writ would be a matter of right.<sup>150</sup>

Astute defense attorneys saw A.B. 1651 as a method of circumventing the harmless error rule. On appeal, a court had often

---

149. Younger, *Prosecution Problems*, 53 A.B.A.J. 695 (1967).

150. CAL. PEN. CODE § 1538.5(i); cf. *People v. Medina*, 6 Cal. 3d 484, 492 P.2d 686, 99 Cal. Rptr. 630 (1972), for a subsequent contrary judicial interpretation.

found a seizure to be unlawful, while holding the error to be harmless. Should illegally seized evidence be litigable prior to trial, no harmless error rule could be applied. It was apparent to defense attorneys that pleas to reduced charges, even outright dismissals, would result. In addition, it is not unreasonably speculative to assume that some defense attorneys saw A.B. 1651 as a vehicle for trial delay through the use of suppression hearing continuances and pretrial writs.

Enactment of § 1538.5 has had bittersweet features for the prosecution. Trial delay occasioned by pretrial appellate review has been relatively infrequent, nevertheless it has caused justifiable alarm. When petitions for hearing reach the supreme court, two year delays from arraignment to trial are not uncommon.<sup>151</sup>

§ 1538.5 has played to mixed reviews from members of the bench. Judges of the Los Angeles Superior Court have been generally critical. According to witnesses testifying before the Assembly Criminal Justice Committee, § 1538.5 has required more court time devoted to criminal matters rather than less; the witnesses argued that defense attorneys feel compelled to bring suppression motions to avoid incompetence of counsel arguments on appeal as much as to litigate substantial fourth amendment issues. § 1538.5 has caused added expense and inconvenience due to the requirement that witnesses attend an additional court session. Judges from San Diego rose to the defense of § 1538.5, claiming that trial delays and the increase in court time have been more than offset by the time saved as a result of the reduced number of cases going to trial.<sup>152</sup>

The defense bar was critical of § 1538.5, generally opposing the prosecution's right of appeal.<sup>153</sup>

There is considerable evidence that § 1538.5 can be used more efficiently. In San Diego County, for example, the superior court sets aside one day a week during which the four criminal departments hear suppression motions and all other pretrial matters exclusively. Rules of Court in San Diego require that a defendant notice all pretrial matters for the same day and court. All counsel

---

151. *Caughlin v. Superior Court*, 4 Cal. 3d 461, 482 P.2d 211, 93 Cal. Rptr. 587 (1971) (twenty-eight months).

152. *Hearings on Pretrial Procedure Before the Assembly Criminal Justice Comm.*, 1972.

153. *Id.*

are required to submit written points and authorities in support of and in opposition to the motions. Finally, trial courts rarely "reconsider" motions once heard, or permit new or renewed motions at the time of trial. The net effect of these court-enforced rules is the reduction of trial delay and facilitation of disposition of motions.

Other counties, *e.g.*, Los Angeles, do not require that all pretrial motions be heard together. The general practice is that pretrial motions, excepting § 1538.5, are heard in advance of trial. The § 1538.5 motion is generally heard on the day of trial. The justification is that witnesses are spared a separate appearance in court for the suppression motion even though there is general agreement that the majority of § 1538.5 motions are heard on the transcript of evidence from the preliminary examination thus eliminating the need for calling witnesses. Whatever the merits of this practice, it appears not coincidental that judges in San Diego generally are in favor of § 1538.5 while those in Los Angeles are generally critical of the section.

The San Diego County District Attorney's Office has established a separate division of deputies to handle pretrial motions and pretrial appellate review exclusively. This concept is also employed in the Orange County District Attorney's Office.

Both the courts and the legislature can improve pretrial procedure. Under the present two court system employed in felony cases, some improvements in the application of § 1538.5 can be accomplished by changes in the local rules of court. These local rules can require that all pretrial motions be held in one hearing, thus reducing the number of court hearings prior to trial. Renewal of § 1538.5 motions can be reduced by a more stringent interpretation of the law.

The California Legislature has considered legislation during its 1972 session which would greatly expand the scope of issues subject to pretrial disposition. Senate Bill 649<sup>154</sup> would require pretrial disposition of fourth, fifth, and sixth amendment issues as well as severance, discovery, and consolidation motions and "[a]ll issues other than that of guilt or innocence that are known or should reasonably be known to the parties which could be decided at a pretrial hearing."<sup>155</sup>

While it is beyond the scope of this article to assess the value of mandatory pretrial disposition as set forth in S.B. 649, it is very

---

154. S.B. 649 (Lagomarsino) (1972).

155. *Id.* at 2.



desirable that the legislature mandate the pretrial disposition of fifth and sixth amendment issues. As noted, courts have recognized in varying circumstances that fifth amendment issues can, indeed must, be determined at a § 1538.5 hearing.<sup>156</sup> Legislative recognition of this fact would dispel confusion by eliminating the unnecessary and artificial requirement of a *dependent* fourth amendment issue. Furthermore, court calendar delays which have been attributed to § 1538.5 are undoubtedly the product in some measure of the arbitrary manner in which constitutional issues are segregated for resolution. Finally, coherent definition of the law resulting from appellate review by *both* defense and prosecution argues persuasively for similarity of treatment for all constitutional issues.

The legislature has also been considering a unified court system whereby the municipal court would be abolished in favor of the superior court.<sup>157</sup> Whatever its merits in other respects, the unified court proposal offers an excellent opportunity for efficient disposition of pretrial issues in felony cases. Under the unified court proposal, there would need be but one evidentiary hearing for all pretrial matters, including probable cause for commitment, and one opportunity for pretrial appellate review of the lower court ruling. This would replace the present system of an evidentiary hearing on search and seizure issues in the municipal court followed by review of that ruling in a § 995 hearing and a second fourth amendment hearing in the superior court followed by a pretrial writ review.

Improvements short of major legislation, at a minimum, would include amendment of Penal Code § 995 to remove fourth amendment issues from its scope. This would eliminate the incentive to bring § 995 and § 1538.5 motions before different judges at different times. If the legislature feels as strongly about crowded court calendars as do those most critical of § 1538.5, it could go as far as removing the right of defendants to pretrial appellate review.

### CONCLUSION

Critical evaluation must be preceded by definition of standards. Unfortunately, most criticism of § 1538.5 is directed exclusively at

---

156. *People v. Superior Court [Mahle]*, 3 Cal. App. 3d 476, 83 Cal. Rptr. 771 (1970).

157. *A.B. 159 (Hayes)* (1972).

its effect on procedural efficiency, ignoring or minimizing its more significant features. The statute's effect on efficiency is incapable of statistical proof because the relevant statistics do not exist.<sup>158</sup> Its other attributes are incapable of statistical proof because they are not susceptible of quantification. Thus, conclusions as to its efficiency must necessarily be grounded on opinion and therefore must be subordinated to other more persuasive factors: (1) Prosecution appeal contributes to the orderly development of the law and is an important addition to California's system of justice. (2) Elimination of trial interruptions has had a positive effect on criminal trial procedure. (3) Accurate assessment of evidence against a defendant permits his entry into plea negotiations from a more informed base. (4) Dismissal by the prosecution of cases involving illegally seized evidence benefits not only the defendant but the entire judicial system.

On balance, one is led to the conclusion that Penal Code § 1538.5 is a valuable addition to the cause of criminal justice.

---

158. *There are no statewide statistics indicating the number of §1538.5 motions which have been brought, nor are there statistics showing the disposition of §1538.5 motions.*

*Pleas, Dismissals, Acquittals*

(Expressed as a % of total felony dispositions in California)

	1966	1967	1968	1969	1970	1971
Dismissal	7.7	7.5	8.0	8.6	8.9	8.2
Plea	61.3	59.9	59.5	63.0	61.0	68.1
Acquittal	7.4	7.9	6.4	6.4	6.8	6.0

—STATE OF CALIF., DEP'T OF JUSTICE, DIVISION OF LAW ENFORCEMENT, BUREAU OF CRIMINAL STATISTICS, FELONY DEFENDANTS DISPOSED OF IN CALIFORNIA COURTS (1971).

Dismissals have increased since 1968, while, simultaneously, acquittals have decreased. These statistics, taken together, could indicate that cases involving unlawfully seized evidence are being dismissed prior to trial rather than going to trial to obtain an acquittal. Pleas of guilty have increased slightly since 1968, giving some comfort to advocates of § 1538.5 who believe that plea negotiations have been facilitated by that section. The inferences drawn from the above statistics obviously must be considered with caution.

The presence of other phenomena might affect the statistics. For example, Penal Code § 17(b)(5), effective in 1968, authorizes the magistrate to accept a misdemeanor plea in the municipal court to any felony which has a misdemeanor minimum penalty. The growing use of § 17(b)(5) suggests that such dispositions will have an impact on nontrial disposition statistics. There are opposing views, however, as to the manner in which such statistics will be affected. One view holds that cases involving questionable seizures result in compromise pleas in the municipal court. The other view holds that a defendant with a substantial fourth amendment issue will not accept a § 17(b)(5) disposition, preferring instead to gamble on an outright dismissal. Finally, the author is unaware of any statistics which measure delays in trial dates occasioned by § 1538.5. See Holmes, *Incorrigible Cahan at Age Fifteen—A Proposal for Civilizing Him*, 45 L.A. BAR BULL. 518, 520, 522 n.20 (1969).



**APPENDIX B**

**(PENAL CODE §1538.5: HEARING & APPELLATE REVIEW; MISDEMEANOR)**  
(RELEVANT PARAGRAPHS OF §1538.5 ARE SHOWN WHERE APPROPRIATE)

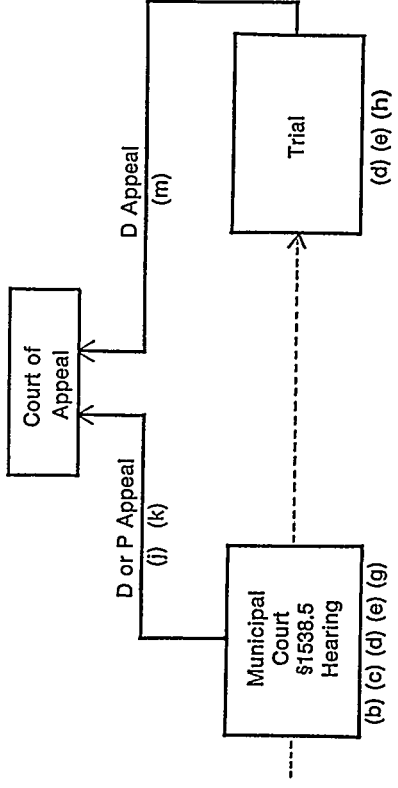

## APPENDIX C

§ 1538.5. [Motion for return of property or suppression as evidence: Special hearings: New complaint or indictment: Appeals: Review by mandate or prohibition: Stay of proceedings: Dismissal of action: Release of defendant: Bail: Motions based on freedom of speech or press]

(a) A defendant may move for the return of property or to suppress as evidence any tangible or intangible thing obtained as a result of a search or seizure on either of the following grounds:

- (1) The search or seizure without a warrant was unreasonable.
- (2) The search or seizure with a warrant was unreasonable because

(i) the warrant is insufficient on its face; (ii) the property or evidence obtained is not that described in the warrant; (iii) there was not probable cause for the issuance of the warrant; (iv) the method of execution of the warrant violated federal or state constitutional standards; or (v) there was any other violation of federal or state constitutional standards.

(b) When consistent with the procedures set forth in this section and subject to the provisions of Section 170 through 170.6 of the Code of Civil Procedure, the motion should first be heard by the magistrate who issued the search warrant if there is a warrant.

(c) Whenever a search or seizure motion is made in the municipal, justice or superior court as provided in this section, the judge or magistrate shall receive evidence on any issue of fact necessary to determine the motion.

(d) If a search or seizure motion is granted pursuant to the proceedings authorized by this section, the property or evidence shall not be admissible against the movant at any trial or other hearing unless further proceedings authorized by this section or Section 1238 or Section 1466 are utilized by the people.

(e) If a search or seizure motion is granted at a trial, the property shall be returned upon order of the court unless it is otherwise subject to lawful detention. If the motion is granted at a special hearing, the property shall be returned upon order of the court only if, after the conclusion of any further proceedings au-

thorized by this section or Section 1238 or Section 1466, the property is not subject to lawful detention or if the time for initiating such proceedings has expired, whichever occurs last. If the motion is granted at a preliminary hearing, the property shall be returned upon order of court after 10 days unless the property is otherwise subject to lawful detention or unless, within that time, further proceedings authorized by this section or Section 1238 are utilized; if they are utilized, the property shall be returned only if, after the conclusion of such proceedings, the property is no longer subject to lawful detention.

(f) If the property or evidence relates to a felony offense initiated by a complaint, the motion may be made in the municipal or justice court at the preliminary hearing.

(g) If the property or evidence relates to a misdemeanor complaint, the motion shall be made in the municipal or justice court before trial and heard prior to trial at a special hearing relating to the validity of the search or seizure. If the property or evidence relates to a misdemeanor filed together with a felony, the procedure provided for a felony in this section and Sections 1238 and 1539 shall be applicable.

(h) If, prior to the trial of a felony or misdemeanor, opportunity for this motion did not exist or the defendant was not aware of the grounds for the motion; the defendant shall have the right to make this motion during the course of trial in the municipal, justice or superior court.

(i) If the property or evidence obtained relates to a felony offense initiated by complaint and the defendant was held to answer at the preliminary hearing, or if the property or evidence relates to a felony offense initiated by indictment, the defendant shall have the right to renew or make the motion in the superior court at a special hearing relating to the validity of the search or seizure which shall be heard prior to trial and at least 10 days after notice to the people unless the people are willing to waive a portion of this time. The defendant shall have the right to litigate the validity of a search or seizure de novo on the basis of the evidence presented at a special hearing. After the special hearing is held in the superior court, any review thereafter desired by the defendant prior to trial shall be by means of an extraordinary writ of mandate or prohibition filed within 30 days after the denial of his motion at the special hearing.

(j) If the property or evidence relates to a felony offense initiated by complaint and the defendant's motion for the return of the property or suppression of the evidence at the preliminary

hearing is granted, and if the defendant is not held to answer at the preliminary hearing, the people may file a new complaint or seek an indictment after the preliminary hearing, and the ruling at the prior hearing shall not be binding in any subsequent proceeding. If the property or evidence relates to a felony offense initiated by complaint and the defendant's motion for the return or suppression of the property or evidence at the preliminary hearing is granted, and if the defendant is held to answer at the preliminary hearing, the ruling at the preliminary hearing shall be binding upon the people unless, upon notice to the defendant and the court in which the preliminary hearing was held and upon the filing of an information, the people within 10 days after the preliminary hearing request in the superior court a special hearing, in which case the validity of the search or seizure shall be relitigated de novo on the basis of the evidence presented at the special hearing, and the defendant shall be entitled, as a matter of right, to a continuance of the special hearing for a period of time up to 30 days. If defendant's motion is granted at a special hearing in the superior court, the people, if they have additional evidence relating to the motion and not presented at the special hearing, shall have the right to show good cause at the trial why such evidence was not presented at the special hearing and why the prior ruling at the special hearing should not be binding, or the people may seek appellate review as provided in subdivision (o), unless the court prior to the time such review is sought has dismissed the case pursuant to Section 1385. If the property or evidence seized relates solely to a misdemeanor complaint, and the defendant made a motion for the return of property or the suppression of evidence in the municipal court or justice court prior to trial, both the people and defendant shall have the right to appeal any decision of that court relating to that motion to the superior court of the county in which such inferior court is located, in accordance with the California Rules of Court provisions governing appeals from municipal and justice courts in criminal cases. If the people prosecute review by appeal or writ to decision, or any review thereof, in a felony or misdemeanor case, it shall be binding upon them.

(k) If the defendant's motion to return property or suppress evidence is granted and the case is dismissed pursuant to Section 1385, or the people appeal in a misdemeanor case pursuant to sub-

division (j), the defendant shall be released pursuant to Section 1318 if he is in custody and not returned to custody unless the proceedings are resumed in the trial court and he is lawfully ordered by the court to be returned to custody.

If the defendant's motion to return property or suppress evidence is granted and the people file a petition for writ of mandate or prohibition pursuant to subdivision (o) or a notice of intention to file such a petition, the defendant shall be released pursuant to Section 1318 unless (1) he is charged with a capital offense in a case where the proof is evident and the presumption great, or (2) he is charged with a noncapital offense defined in Chapter 1 (commencing with Section 187) of Title 8 of Part 1 and the court orders that the defendant be discharged from actual custody upon bail.

(1) If the defendant's motion to return property or suppress evidence is granted, the trial of a criminal case shall be stayed to a specified date pending the termination in the appellate courts of this state of the proceedings provided for in this section, Section 1238, or Section 1466 and, except upon stipulation of the parties, pending the time for the initiation of such proceedings. Upon the termination of such proceedings, the defendant shall be brought to trial as provided by Section 1382, and subject to the provisions of Section 1382, whenever the people have sought and been denied appellate review pursuant to subdivision (o), the defendant shall be entitled to have the action dismissed if he is not brought to trial within 30 days of the date of the order which is the last denial of the petition. Nothing contained in this subdivision shall prohibit a court, at the same time as it rules upon the search and seizure motion, from dismissing a case pursuant to Section 1385 when such dismissal is upon the court's own motion and is based upon an order at the special hearing granting defendant's motion to return property or suppress evidence. In a misdemeanor case, the defendant shall be entitled to a continuance of up to 30 days if he intends to file a motion to return property or suppress evidence and needs this time to prepare for the special hearing on the motion. In case of an appeal by the defendant in a misdemeanor case from the denial of such motion, he shall be entitled to bail as a matter of right, and, in the discretion of the trial or appellate court, may be released on his own recognizance pursuant to Section 1318.4.

(m) The proceedings provided for in this section; Section 995, Section 1238, and Section 1466 shall constitute the sole and exclusive remedies prior to conviction to test the unreasonableness of a



search or seizure where the person making the motion for the return of property or the suppression of evidence is a defendant in a criminal case and the property or thing has been offered or will be offered as evidence against him. A defendant may seek further review of the validity of a search or seizure on appeal from a conviction in a criminal case notwithstanding the fact that such judgment of conviction is predicated upon a plea of guilty. Such review on appeal may be obtained by the defendant providing that at some stage of the proceedings prior to conviction he has moved for the return of property or the suppression of the evidence.

(n) Nothing contained in this section shall prohibit a person from making a motion, otherwise permitted by law, to return property, brought on the ground that the property obtained is protected by the free speech and press provisions of the Federal and State Constitutions. Nothing in this section shall be construed as altering (i) the law of standing to raise the issue of an unreasonable search or seizure; (ii) the law relating to the status of the person conducting the search or seizure; (iii) the law relating to the burden of proof regarding the search or seizure; (iv) the law relating to the reasonableness of a search or seizure regardless of any warrant which may have been utilized; or (v) the procedure and law relating to a motion made pursuant to Section 995 or the procedures which may be initiated after the granting or denial of such a motion.

(o) Within 30 days after a defendant's motion is granted at a special hearing in the superior court, the people may file a petition for writ of mandate or prohibition, seeking appellate review of the ruling regarding the search or seizure motion. If the trial of a criminal case is set for a date which is less than 30 days from the granting of a defendant's motion at a special hearing in the superior court, people, if they have not filed such a petition and wish to preserve their right to file such a petition, shall file in the superior court on or before the trial date or within 10 days after the special hearing, whichever occurs last, a notice of intention to file such a petition and shall serve a copy of the notice upon the defendant.