

---

Theses, Dissertations, and Other Capstone Projects

---

2013

# Technical Direction for Abe Burrows' Cactus Flower

Lawrence A. Lopez

*Minnesota State University - Mankato*

Follow this and additional works at: <http://cornerstone.lib.mnsu.edu/etds>

 Part of the [Fine Arts Commons](#), and the [Performance Studies Commons](#)

---

## Recommended Citation

Lopez, Lawrence A., "Technical Direction for Abe Burrows' Cactus Flower" (2013). *Theses, Dissertations, and Other Capstone Projects*. Paper 188.

This Thesis is brought to you for free and open access by Cornerstone: A Collection of Scholarly and Creative Works for Minnesota State University, Mankato. It has been accepted for inclusion in Theses, Dissertations, and Other Capstone Projects by an authorized administrator of Cornerstone: A Collection of Scholarly and Creative Works for Minnesota State University, Mankato.

TECHNICAL DIRECTION FOR ABE BURROWS'

*CACTUS FLOWER*

by

LAWRENCE A. LOPEZ

A THESIS SUBMITTED

IN PARTIAL FULFILLMENT

OF THE REQUIREMENTS FOR THE DEGREE

MASTER OF FINE ARTS

IN

THEATRE ARTS

MINNESOTA STATE UNIVERSITY, MANKATO

MANKATO, MINNESOTA

APRIL, 2013

Date\_\_\_\_\_

This thesis has been examined and approved.

Examining Committee:

\_\_\_\_\_  
George Grubb, Chairperson

\_\_\_\_\_  
David McCarl

\_\_\_\_\_  
John Paul

\_\_\_\_\_  
Steve Druschel

\_\_\_\_\_  
Paul Finocchiaro

\_\_\_\_\_  
Steven Smith

## ABSTRACT

Lopez, Lawrence Andrew, M.F.A. Technical Direction for Abe Burrows' *Cactus Flower*.

Mankato: Minnesota State University, Mankato, 2013.

This thesis is submitted in partial fulfillment of the Master of Fine Arts degree in theatre. It was completed by technical director Lawrence Andrew Lopez at Minnesota State University, Mankato. This paper is a comprehensive report of Lopez's production process of Abe Burrows' play *Cactus Flower* which was performed in the Ted Paul theatre November 8<sup>th</sup> through 18<sup>th</sup>, 2012. It is a record of Lopez's particular process from pre-production analysis to an examination of the final product manifested in the scenery for the production. It examines this production process in five chapters: pre-production analysis, historical and critical analysis, a production journal, post-production analysis and a record of process development concluding with three appendices and a works cited page.

## ACKNOWLEDGEMENTS

The author would like to thank all of those who helped bring this project to fruition: George Grubb, for his unending support, advice and assistance throughout the process, without which *Cactus Flower* would not have been a success. Lopez would like to thank Noah Files, for his enthusiasm, creativity and adaptability in the collaborative process of creating this production, Steve Smith, for his endless enthusiasm and optimism that made this difficult process much smoother, Paul Finocchiaro, whose flexibility and excitement were constant inspiration to everyone on the production team, and to David McCarl, John Paul and Steve Druschel, who served on his committee. Finally, thank you to all the others who supported the author throughout the process, especially the shop staff who did excellent work.

## TABLE OF CONTENTS

## Chapter

I.	PRE-PRODUCTION ANALYSIS.....	1
II.	HISTORICAL AND CRITICAL PERSPECTIVE.....	8
III.	JOURNAL.....	17
IV.	POST-PRODUCTION ANALYSIS.....	39
V.	PROCESS DEVELOPMENT.....	50

## Appendix

A.	WORKING/SHOP DRAWINGS.....	57
B.	PROCESS PHOTOGRAPHS.....	73
C.	PRODUCTION/MODEL PHOTOGRAPHS.....	88
	WORKS CITED.....	105

## CHAPTER I

## PRE PRODUCTION ANALYSIS

Abe Burrows' *Cactus Flower* will be produced at Minnesota State University, Mankato and performed in the Ted Paul Theatre in November of 2012. The production will be directed by Professor Paul Finocchiaro with scenic design by Noah Files, costume design by Professor David McCarl, sound design by faculty member George Grubb, lighting design by Professor Steve Smith and technical direction by Andrew Lopez, a candidate for a Masters of Fine Arts degree in technical direction at Minnesota State, Mankato.

Burrows' play is a classic example of a romantic comedy, a light hearted, funny show that usually ends with a happy couple. This play tells the story of a dentist, Dr. Julian Winston, and the web of deceit that he weaves around his life and how he manages to extricate himself and get the girl. However, the girl he gets is not the girl he expected. The play opens on Toni Simmons' apartment, where the audience finds Toni lying on her mattress with the oven door open. Toni's suicide attempt has been inspired by her lover, Julian, who has convinced her that he is married and has three children, thus eliminating any chance of a future together. Julian, however, is not a married man but simply a philandering doctor with a penchant for young women. He originally concocted the story of his wife in order to keep Toni at arm's length. Julian panics over Toni's suicide attempt and tries to propose to her in a fit of guilt. Toni insists on

meeting this fictional wife, forcing Julian to enlist his reluctant secretary, Stephanie Dickenson, to stand in for his wife. Toni, after meeting with Stephanie, finds that she can't bear the thought of Julian divorcing his wife since she obviously still loves him. The plot complicates when Toni manipulates Julian into finding Stephanie a new beau so that everyone can live happily ever after. When the truth of Julian's lying is revealed, Toni leaves him for Igor, her neighbor. Julian, after his initial anger, realizes that marrying Toni would have been a colossal mistake and tells himself to "go home to his wife" before realizing that he has no wife, and that Stephanie will be gone when he gets back to work (Act 2 Scene 7 p 79). He then proceeds to get drunk and stumbles into the office the following day, late. Stephanie is there, visibly upset by the fight they had the previous day until Julian reveals everything to her, and they both realize that their behavior through this mess was influenced by a mutual love, and they kiss. In the end, both guys get the girl, though not the one you would think.

This complicated plot takes place in four primary locations: Julian's dental office, Toni's apartment, a nightspot downtown and the record shop where Toni works. Files' design requires the use of moving platforms and flown units to expedite the scene shifts, thereby supporting the fast pace of the show, as well as simplifying set changes. *Cactus Flower* is a very cinematic script, in which scenes flow rapidly from one to the next, often changing locations several times within a very short period of time. Files' design supports the rapid location changes by allowing the stage hands to handle the scene shifts quickly and safely. Files' concept is to borrow from period artists' styles for



each of the major set pieces, but creating the “canvas” for his paint and set dressing will require solid construction and the ability to move the set around to create the look that is required. In order to effectively examine this style of scenery for the potential problem areas, each location must be examined separately, and evaluated independently of the rest of set. Once each location has been thoroughly analyzed, the set as a whole should be examined to find the most efficient way to perform the scene shifts.

The largest, and potentially most troublesome of the sets will be the apartment. Files has based this on a sixteen foot square platform with walls on two sides to connect in the upstage corner. While this would be a very effective design for a stationary box set, it is difficult to make twelve foot walls stable on a rolling platform. Compounding the problem of creating stable walls on a mobile platform where they cannot be stabilized with jacks, is the inclusion of a functional window that will require an actor to climb through on the stage left wall, and two doors that must open offstage on the stage right wall. Doors have continually proved challenging for Lopez to install in a flat since opening the door will change the center of balance in the flat which can make the walls lean. Additionally, slammed doors will make the wall shake, since the wall of a set has significantly less structural support than real walls. Due to the way the designer wishes to use this unit, the platform must be no more than sixteen feet square, leaving no space behind the walls on the platform to install support. The other side of the stage left wall is also used as the main wall for the record shop.

The record shop set uses the back of one wall of the apartment set, so it will have similar challenges with wall stability. Additionally, this space needs a tall set of shelves with a ladder and this location will need a door as well. The designer wishes to use the back of the apartment wall that has a window, therefore adding a door to the record shop will most likely require another wall. Several solutions to this issue could be implemented, but currently attaching a removable wall on the back corner of the platform appears to be the best, and it must be this corner since the director wished to have the entrance from stage left. A permanent extension could work, but might interfere with the apartment unit successfully being stored between scenes when it is not required. Hinging the door wall to the rest of the set could provide a way around space problems but the door wall would not be as stable because the connection would be much more tenuous. Finally, making the door wall a separate piece that attaches to the larger set would allow it to be self-supporting, allowing the door to roll on and attach somehow to the larger set. This might be the best solution to pursue, but currently the location for this set on the stage has not been finalized, which will affect the angle in which the door must attach to the rest of the set. Finishing the record shop set will be several more pieces that should present no significant challenge. The record racks, the point of sale and the listening booth to cover the window in the wall are all minimally complicated.

Assembling the platform for the apartment and the rear wall of the record shop will also prove challenging, since the platform must be mobile. Each platform will need

casters, and then be attached to the others. The traditional method in the Minnesota State, Mankato scene shop is to use 3/8" by 3 1/2" bolts through the framing to attach platforms together following the attachment of casters; however this presents a safety concern. Once the platforms are securely bolted, the whole unit is flipped over onto the wheels. The safety issue with a sixteen by sixteen platform built from eight 4 foot by 8 foot platforms is the seam through the middle, which is a weak spot. Coffin locks, a two part lock that uses a cam turned by a hexagonal key to lock the two sides together accessed from the top of the platform, could provide a solution to this problem as they would allow the platforms to be connected after they are on their casters. However, this could present a secondary issue if the coffin locks fail to line up properly when the platforms are together. Another possible solution would be to use the coffin locks to connect two halves of the large platform together after they have been bolted together. Flipping a platform that is eight by sixteen feet is safer since the seams will all be vertical when the platform is on edge, and it will be easier to support a platform that is eight feet tall rather than sixteen feet.

The dentist's office consists of two independant rolling walls, a desk, and a waiting area. The walls are probably the most challenging part of this set since they are tall, and supposed to have the appearance of being free standing; however their location also eliminates the option to fly the walls since the designer would like to see these two walls set at an angle to the proscenium. These walls will require some form of mobile support, as well as some way to weight the back of the wall to keep it from

tipping forward. Mounting the walls on the downstage edge of wheeled platforms will provide a surface to connect supports to, as well as a surface for counterweight bricks. This combination will create a moving wall that will be stable, not prone to tipping and still be easy to move. The desk will be a separate unit, likely built into another wheeled platform that will be locked to the front of the downstage wall. Any other furniture should not need casters since it will be easy to carry.

The last set to discuss is the nightclub, which presents two significant set pieces that will require careful engineering. There will be a flown wall with an opening filled with a bead curtain, and two banquettes, half round seating units on casters that will be placed stage left and right. The wall, with appropriate preparation, should not present any difficulties. The real challenge will be building the banquettes. The designer wishes to have a curved back around half of a six foot circle, which results in a compound curve. Designing and building these banquettes will be an engineering challenge, requiring a certain amount of trial and error. This method will compensate for Lopez's lack of training in the math required for calculating the surface and the process should be simplified by modeling a banquette in AutoCAD.

A mobile set requires more from the technical director because in addition to designing the construction of each set piece, he or she is also responsible for facilitating the process of each scene shift. In order to accomplish this Lopez will have to work closely with the director, stage manager and stage hands to plan out the scene changes choreographed by the director to accomplish a smooth transition that can be repeated

every night, as well as successfully store all of the sets offstage when they are not required. Much of this is accomplished through multiple meetings with the stage manager and the director while the actual scene shifts are choreographed during technical rehearsal. This will be the first show that Lopez has had to deal with this particular aspect of technical direction, and rising to the challenge of working with a shift crew partially composed of stage hands and partially of actors will likely be the most challenging aspect of an already challenging set build.

## CHAPTER 2

### HISTORICAL AND CRITICAL PERSPECTIVE

Abe Burrows began his career shortly after the turn of the 20th century. It was an exciting time for the entertainment industry as technology found new ways to reach audiences. Change was imminent as new forms of entertainment in the forms of radio and television began to take hold. Burrows' love of entertaining most likely started with his father, who shared the songs of vaudeville with the young Burrows by singing them at home accompanied by the piano. Early exposure instilled a love of entertaining in the young Burrows, eventually leading him into taking a chance on a career writing for radio. Burrows' memoirs recall his first real writing job shortly after the stock market crash of 1929, in which he began to collaborate with Frank Galen. Burrows states, "When I saw him typing, and I saw that paper in the typewriter, I had the strangest, most marvelous feeling. If I were putting this scene on stage today, the kid who was playing me would stop dead in his tracks and the orchestra would play a sharp knife chord. Zing! Then they would go into the 'Hallelujah Chorus'" (*Honest Abe* 35). This short paragraph encompasses a significant portion of Burrows' career as a writer, performer and director emphasizing his passion as an entertainer. This chapter will briefly discuss Burrows' career, focusing on his decision to leave radio for the stage, and

how his early career writing for television and radio influenced his later work as a playwright.

Burrows entertainment career truly began when he started collaborating with Frank Galen. Galen and Burrows met while Burrows was working as a salesman selling ladies knitted garments. A former employer, one Milton Cohen, introduced him to Galen based on Burrows sense of humor and habit of cracking jokes at work. Burrows quotes Cohen, "Hey, Abe. You're always saying pretty funny things. Why don't you do something about it?" (*Honest Abe* 34). Burrows reluctantly accepted the offer to meet with Galen. The two began to write together with the goal of selling jokes and hopefully making a living. Their first big break came when they managed to sell a set of jokes to Eddie Garr, a vaudeville comedian and actor. Their first set of jokes sold for \$125, which, in Burrows' own words, made him "sixty-two fifty apiece. I was a professional" (38)! In spite of Burrows' success with Garr, his professional success was limited until he was introduced to Ed Gardner when Eddie Garr was asked to do a guest spot on *This is New York*, a popular radio show.

Burrows and Galen were later picked up as writers for Wilbur Budd Hulick, known as Colonel Stoopnagle, who was one half of the radio comedy team Stoopnagle and Budd. They wrote a spot each week until the end of summer 1939, at which point Gardner brought them on to write for *The Texaco Star Theatre* which moved Burrows to Hollywood. In 1940 Frank Galen and Burrows went their separate ways when Burrows followed Gardner back to New York where the two ended up working with Rudy Vallee

and John Barrymore until 1941 when Gardner's idea for *Duffy's Tavern* finally found a sponsor. *Duffy's Tavern*, a radio variety show, provided Burrows with a steady job. Burrows would write for *Duffy's Tavern* from 1941 through 1945, a show that could be said to have the most influence on his later work for the stage. It was during this period that he also began to write and sing songs at local parties. This is also the time when Burrows first began to work with Frank Loesser, and a time when he began to be a performer as well as a writer. Burrows began to perform his songs for parties and quickly found that he was a desirable party guest despite his lack of formal training in singing and the piano. Burrows mainly wrote songs to politely rib the professional songwriters. While his own talent was limited; he still became a popular guest because of his desire to sing his goofy little ditties. During this time, Burrows proudly hung onto his amateur status because he "was never paid a cent for [his] labor" as a songwriter (*Honest Abe* 76).

Burrows continued to write for *Duffy's Tavern* while he took a short jaunt into the cinema. While his movie career was short lived, it did provide a natural path to working in television, where Burrows would work with such greats as George Kaufman and many others. During this period Burrows was working on up to three television shows, and began to collaborate with Frank Loesser on the script for *Guys and Dolls*. This show was to be Burrows' first Broadway success. It was not to be his last.

*Guys and Dolls* is based on a story by Damon Runyon about a young, beautiful missionary who falls for a New York gambler and cures him of his wicked ways. Burrows



was brought in to help get the script off the ground when the original writers ran into trouble. This was also a first for Burrows, though not the last time he was called to assist a floundering script. George Kaufman became Burrows' teacher during this time, helping him take the difficult steps from radio to stage. Burrows recalls Kaufman in his memoir as a man who wasted no words, and demanded punctuality and perfection. While working under Kaufman was not easy, it did make Burrows a better writer, open his way to Broadway, and make his first major production into a classic that is still performed today. *Guys and Dolls* secured Burrows' name as a show doctor, a reputation he would carry with him throughout the rest of his career. It is valuable to note that Burrows worked on many shows during his live theatre career, such as *How to Succeed in Business Without Really Trying*, *Can-Can*, and *Make a Wish* (Burrows). Many of these works were either co-written, or in some cases like *Make a Wish* he is uncredited as the playwright (*Honest Abe*).

Radio and television scripts differ from stage scripts in several different ways, and Burrows' work reflects many of these differences when we examine the specifics of those differences in the context of *Cactus Flower*. Writing for the radio and television demands certain requirements of the author. The requirements of the sponsors, the legal restrictions, and the target audience can all force the author to operate under specific conditions, restricting the breadth of their creativity. Skilled writers can learn to express themselves equally well under these conditions, but if they choose to write for

the stage, their prior experience with writing for broadcast may influence the structure of their subsequent work.

The restrictions that broadcast writers operate under include a number of outside sources, including Federal Communications Commission requirements concerning offensive material and controversial issues, maintaining sensitivity to product requirements and keeping within the needs of their sponsors (Willis 6-8). The first of these, offensive material, has changed since the FCC was formed in 1934, but the broadcast author must still be aware of current regulations and abide by them. In addition to FCC regulations, there are also the station codes to abide by, rules that determine what will make it on the air, and what is unacceptable.

Along with the restrictions imposed by regulations, there are also the working conditions that broadcast writers operate under. Radio and television programs usually have a new episode weekly, which necessitates a very rapid production schedule. The writers must take a new script from concept to completion in time for the next deadline, which will include recording time if the show is not to be presented live. This schedule encourages writing comedy that depends on stock jokes and gags rather than more sophisticated forms of humor. Burrows was famed for his sense of humor and his ability to make jokes about nearly anything. His natural talent enabled him to excel, but beyond that talent he needed to develop certain skills that would help him deal with the difficult schedule and demands of the broadcast environment. Of these skills, two would continue to be seen in his stage writing; the first being the use of stock jokes and

gags to elicit laughter, pulling from a “file of jokes” disguised through appropriation of the basic point, but cast into an appropriate context (Willis 296). The second is the short scenes that take place in a number of different locations coupled with an early point of attack designed to snare the audience’s interest as quickly as possible. Both of these allow for the quick generation of a script that will still keep the audience interested.

Edgar E. Willis opens the sixth chapter of his book, *Writing Television and Radio Programs* by considering the average television viewer, though his thoughts could apply to radio as well, flipping his way through channels looking for something interesting to watch. He says “If you fail to engage his interest at once, he will turn restlessly to another channel or switch off the set entirely.” (93). While grabbing the audience’s attention is still critical with movies or live performance, the initial attack does not have to be as early because the audience, having paid their money, is much less likely to wander out and look for other entertainment.

While *Cactus Flower* is a play, the attack comes in the very first scene as the curtain rises on the prone form of Toni on her bed, and Igor frantically tapping at the door. The early point of attack coupled with the immediacy of the situation (Toni is attempting suicide) captures the audience’s attention immediately and also sets the scene up for the first joke as Toni kisses Igor while he tries to resuscitate her. Following the first scene, the location jumps immediately to Julian’s office, where the audience is introduced to the rest of the primary cast and the story continues. The very next scene is back in Toni’s apartment, followed shortly by a return to the office. The scenes

continue to jump around from location to location, frequently running under 20 minutes in length. These short scenes are very typical of television and radio programs, which must take periodic breaks for advertisements and station breaks (Willis 113). Burrows developed this style while writing for broadcast. *Cactus Flower* is a prime example, with seven scenes in the first act and eight in the second in a show that runs under 2 hours.

The cinematic quality of the scene layout is reflected in the dialogue and interactions between the characters. The humor in *Cactus Flower* is clearly influenced by television situation comedy, and by radio comedy that depends more on clever lines and snappy dialogue than on physical humor. Burrows wrote broadcast comedy for nearly two decades, and in that time, honed his innate talent into a keen ability to find the joke in nearly every situation. Part of this ability comes from developing an internal “file” of jokes that can be modified to fit the situation. People laugh for various reasons, but they are all as intensely personal as the things that would make them cry (Willis 282). Laughter stems from a number of sources, but the most basic forms are triumph, incongruity, or surprise. Each of these forms has a number of sub-forms and can be combined to create the various types of comedy shows. *Cactus Flower* could best be described as a situation comedy, where the humor comes from basically ordinary people caught in a funny situation. However, the jokes make use of each of the three basic forms of humor. Igor and Toni stand triumphant over Julian as he is caught in his web of lies, and we laugh. Julian bursts into Toni’s apartment expecting the worst, only to find her sitting primly at her table reading a magazine, and the audience laughs at

Julian's overreaction. Finally, there is the laughter directed at surprise, such as the scene where Toni decides to give the mink stole gifted to her by Julian to Stephanie as a surprise gift and conciliatory gesture. Toni finishes her plan with the line, "Now we're all even. I stole her husband, I gave her a stole." (Act 2 Scene 2).

*Cactus Flower*, based on the French play *Fleur de Cactus*, originally came to Burrows as a literal translation, which "didn't enchant me." (Burrows 311). While Burrows had to be talked into adapting the play for an American audience, the final result took off on Broadway, giving Burrows one of Broadway's biggest hits with his name on the script. This is a unique aspect of Burrows writing career for the stage. Many of the plays that he had a hand in were either co-written with other playwrights such as *Guys and Dolls*, or he was simply not credited for his work as in *Make a Wish*. *Cactus Flower* stands out from the rest of Burrows' work in that he wrote it alone. *Cactus Flower* opened on December 8<sup>th</sup>, 1965 at the Theatre Royale, where it continued to run until November 23<sup>rd</sup> 1968, transferring to the Longacre, and ultimately running for 1234 performances. Reviews from Time and Newsweek are lukewarm. While the reviewers were not outright hostile, they felt that the strength of the piece came from the actors. With Lauren Bacall, Brenda Vaccaro, Burt Brinkerhoff and Barry Nelson leading the cast, the reviewers felt the show had strong performers who helped make the run a success.

Such was the success of *Cactus Flower* on stage, that in 1969, the show was revived on screen starring Walter Matthau as Julian and Goldie Hawn as Toni, with

Ingrid Bergman as Stephanie Dickenson. Reviews from both Time and Newsweek showed a simultaneous astonishment at how well this script translated from stage to screen. Typically, play scripts need significant rewrites to become successful film scripts. *Cactus Flower*, because of Burrows' background in broadcast media, translated beautifully because Burrows understood the needs of a film script, having worked on several, and used that understanding to write a play that works equally well for stage or screen. Burrows' talent for humor, combined with his prior experience writing for broadcast made the transition from stage to screen easy, and successful according to the reviewers.

Burrows' unique wit, coupled with an unusual employment background for a playwright allowed him to bring *Cactus Flower* to fruition. Even today, this play retains its relevance because of the sparkling wit of the playwright who crafted a piece that, while not innovative, touched something elemental.

## CHAPTER III

## JOURNAL

August 31, 2012

Today was the first concept meeting for *Cactus Flower*. Director Paul Finocchiaro presented his interpretations and desires for the production, after which we went around the table with each designer expressing their ideas. One of the ideas that Finocchiaro suggested was the idea of reflecting the transformation of Stephanie in the set, with transformations and visible set changes. Based on Finocchiaro's interest in transformations, and Set designer Noah Files' expressed interest in creating moving set pieces, this production could provide me with the chance to use automation in a project, which is very exciting. I will need to maintain decorum; hopefully Files will be interested in trying out something new. While it is still very early in the process, I try to look for any opportunity to use techniques that I haven't used before.

September 7, 2012

The production meeting was interesting. Files brought in some concept sketches and ideas for the nightclub scene along with some general research into furniture and art from the period. Files' drawing for the nightclub looked very interesting, and potentially a deeply challenging project because he wants to build round banquettes or seating booths with an integrated table and seating bench. Further research into

materials will be required, as will a three dimensional model. I think that the best way to achieve the look that Files wants is to create the model in AutoCAD, and then use that model to experiment with possible construction options. This will allow for multiple solutions without the need to actually build anything.

September 14, 2012

Our third production meeting brought more research from Files, this time looking at architecture and furniture. Finocciarro expressed interest in seeing windows, especially in the record store, and spoke of a Plexiglas listening booth on stage. I am a little concerned based on the price of plexiglass, but research and ingenuity should help provide something that will be satisfactory without going over budget. Four locations on \$1200 is difficult, but not impossible. AutoCAD will be very useful for figuring out the more intricate set pieces as they are designed.

September 17, 2012

I still haven't done a lot of work on the set since Files is still gathering research and stewing ideas. It has been a huge help to have the designer of the set so accessible, so that when problems or ideas arise, we can have an immediate conference. Some of the most interesting ideas have come from these little impromptu meetings where we are able to throw around thoughts without worrying about how feasible they might be.



I am concerned about the number of rolling set pieces for this show, but Grubb has mentioned that casters do not necessarily have to come from the budget for the show, but could come from general shop funds. Buying casters with shop funds instead of show budget will help a lot since we have such a small budget. Recalled from last Friday, I will have to create record shelves for the shop. I'm not sure what Files wants, but have been mulling over possibilities to prepare for the construction process.

September 21, 2012

Finocchiaro wants to have a big reveal moment at the start of the show with Toni in her apartment. He wants to use a scrim drop to keep the stage obscured until the lights go up and the set unit is revealed, then the scrim will fly and the apartment unit will glide downstage.

Our first build day starts in a little over a week, and I still am not sure about many things. Files is to bring in his model next week, and I'm anxious about what will be revealed by his ideas. Overall, the biggest challenges are going to be creating a multi-location set with so little wing space, and working within our budget to make everything that we need without spending too much. The Ted Paul theatre has shallow wings, which will limit our ability to store large set pieces while still maintaining easy access. The stage left wing opens into the shop, but there is a ramp there that could affect the motion of any rolling units heading that way. Furthermore, the legs might need to be moved to allow enough room between them for set pieces to roll on without having to

breast the legs out of the way. The apartment seems like it will be the largest of the set pieces, followed by the office. The nightclub and record store should be smaller, with fewer parts to build and fewer parts to store.

September 28, 2012

I did not have a meeting with Faculty tech advisor George Grubb this week, but I did speak to Files several times about what he wants with each of the major units. Together, we figured out that the record shop and apartment can play on the same unit by rotating the platform around and using the back of one apartment wall as the interior wall of the record shop. This will tie into the director's request for visible transformations, while saving space in the wings by reusing what is turning into a fairly large piece. From the production meeting, the apartment is a sixteen foot square platform with walls on two perpendicular sides meeting in the upstage corner. As Files and I had discussed earlier, by turning the platform around so that the back of one of the walls faces downstage, and adding in a bookshelf and door combination, we can have the record shop. I was really intrigued by the possibilities of this decision, since it will require some precision work with casters and with added on platforms to the main one to provide for accessory scenes. The banquettes for the nightclub are currently a significant budget concern since they are going to need upholstering, but we don't currently know how much will be upholstered. I need to draft one to figure out the

construction of a double curved back, which could also help decide if the back will require upholstery or not.

October 5, 2012

My meeting with Grubb this week focused on project paperwork. The production meeting saw changes to the set, several of the walls have changed shape slightly. The office walls slant toward each other along the tops, and one of the apartment walls has an angled top as well. We were due to start the build this week, but I have decided that in light of both *A Chorus Line* and *The Mandrake* being in production, to push back a week and just work on small projects that I can do alone when I have time. I will be ordering lumber over the weekend and prepping to start building set pieces on Monday, since we will have opened *A Chorus Line*. My biggest problem right now is a lack of space in the shop. There have been chair racks and hampers in the shop since we finished the seating shift at the end of August, making it difficult to find the space needed to build. While space is usually a problem, the issue has been exacerbated by the current seating configuration, which has made it impossible to store chair racks and soft goods hampers under the risers. Consequently, the chair racks and hampers have migrated to the shop floor and the loading dock tunnel, where they are in the way.

October 8, 2012

I worked alone most of the day, but I was able to build a record box. I used 1/2" plywood to build the main structure, and it will sit on legs, most likely 2x4 cut in half. Files and I have talked about these several times, and he is happy with the results. I made a lumber order this morning, and have arranged for delivery tomorrow afternoon. Calculating needs was interesting, as I was felt I was fighting against the placement of the doors and window in the Apartment. I also have determined that I need 48 casters, and after spending an hour or so digging through stock, I have come up with 28, and another 14 on dollies and carts. Grubb has suggested I source through Gopher Stage in Minneapolis for more, and I found what I think is the right caster and sent an e-mail to them hoping for a decent price.

October 9, 2012

I have had very few staff in this week for some reason. I know *The Mandrake* has required a lot of time, but it seems like there are people simply failing to show up when they are supposed to. I had a team work on legging the box that I built yesterday, but while they were working on it, I found a mistake. I had cut some of the pieces too tall, which required the box to be modified before the legs could be finished. The modifications took somewhat longer than I wanted, but I am working with unskilled labor. These kind of mistakes frequently cost time and materials, neither of which are in huge supply. The materials are leftover from earlier this semester, but the time is

something that we can't spare. It was also somewhat irritating that the mistakes were mine. While no one is perfect, I do strive for accuracy and a measuring mistake can be very costly. I also counted coffin locks for use on the platforms, and came up short on those. Coffin locks use a cam turned by a hexagonal key to lock their two halves together tightly. They are very useful in creating large platforms from smaller platforms because they allow the platforms to be locked together from the top. Grubb has allowed another purchase from shop funds for more, so I ordered 10 additional locks. Production has been slow so far, and it has been frustrating. I also feel that my productivity outside of the shop has been low, I don't know why I have been struggling with keeping on task and doing the work I need to do, but hopefully I can get through it and finish the semester strong. I have heard back from Gopher Stage, \$46 per caster for the ones I found and \$25 in shipping. I have forwarded the e-mail to Grubb, and we'll see what he says. I am wondering if I found the right caster.

October 10, 2012

Files came up with a plan that has made the additional coffin locks I ordered unnecessary. I wanted to use coffin locks on the sixteen foot square platform that makes up the base of the apartment unit because flipping a platform that large with a horizontal seam, even with bolts holding the platform together, seems dangerous. Files' suggestion to make two eight by sixteen platforms and then use the coffin locks between those two saves time and locks, so I agreed and we have spent time modifying

platforms to install the coffin locks. I have discovered that many of the platforms in the pile are either not the right size, or those that are have been abused to the point of needing to be rebuilt. This will slow us down, but I want strong platforms that can stand up to being turned into a wagon and rolled around a stage. My lumber also arrived, I am ready to start building walls as soon as I have the space to do so. *A Chorus Line* strikes this weekend, which will allow us to start putting projects on stage. I'm looking forward to the additional space. Drafting continues slowly. I have been essentially re-learning AutoCAD, which has slowed down the process, but I think it will result in much more accurate drafting. Grubb replied to my forward indicating that I had not found the right caster, but he linked the correct caster and I have forwarded that back to my contact hoping for a lower price.

October 11, 2012

We are beginning to feel the pressure of *The Mandrake* as well. They start technical rehearsals tomorrow, and are not ready. I have continued to supervise the modification of platforms, while waiting to have the stage to work on. Gopher stage replied with a new price of \$28 per caster, and I am waiting for a chance to order what I need. I have been very busy at work, but my lack of productivity at home is starting to be a problem. I can get homework done, and have been working on that, but I feel like sometimes I can't get work done while my daughter is awake and that causes me to simply ignore important tasks while I am dealing with her. I have continued to slog

away at my research, but have not written a word other than my journaling. I'm hoping for better productivity after the weekend.

October 12, 2012

The production meeting was nothing new. I announced our progress and we looked at some lighting changes. Shop time was productive, but *The Mandrake* has really been pulling staff away from building *Cactus Flower*. *Mandrake* starts technical rehearsals tonight, so I am hoping that Monday will give me more staff to work with. I have gotten the go ahead to order casters, but I heard late enough that I did not get an accurate count of how many I need if I do not use the casters that are already in use. The platforms are moving along, but the lack of space in the shop has slowed our work down considerably. I'm also concerned about staff failing to show up for their shifts. I have decided to take attendance next week with a new schedule to try to figure out who is not coming in, and who might not be on the schedule correctly. This scheduling thing is a real headache, but this is a job that I will be required to do professionally, so the practice now is good.

October 16, 2012

We started building walls today, since we are still waiting for casters. *The Mandrake* is nearing final dress, which has lessened the demand for more staff in favor of more careful staff. As a result, many of my more experienced workers have been

moved to that show, which means I have taken a more active role in supervision within the shop. I find that working with inexperienced shop staff is exciting because I have the opportunity to teach them new and useful skills, but at the same time it can be very frustrating as some of the newcomers are not very enthusiastic. I have heard back from Gopher Stage, they have put in the order to be drop-shipped directly to the university. Unfortunately, there was no ETA on the shipping, which leaves me with the difficult situation of being unable to move forward with the apartment platform until the casters arrive. There are more walls to construct, as well as some smaller set pieces to work on. We have plenty to do until casters arrive.

Files and I had another chance to talk about the needs for the record shop, including the point of sale desk, and the listening booth. The desk may be in props, but the booth is a project that will require some time and effort. Files wants a bi-fold door, possibly with a window, to close the booth. A door like that would be an interesting challenge to build, but would also be somewhat expensive to make. I would enjoy the difficulty of engineering the door to fit the needs of the booth.

October 17, 2012

We continued building the apartment flats, though as we move forward, the lack of casters will begin to be more of a problem. There are plenty of flats to build, though, so we will keep moving forward with what we can until all the parts we need have arrived. As the flats get finished, we have moved on to base coating in preparation for



paint. Email conversations with my contact at Gopher Stage indicate that my casters should be arriving soon. I will keep in touch with shipping while I wait.

In addition to working on walls, I have begun to figure out what I am planning to do to provide for the window stunt. The script calls for Igor to break one of the panes in order to reach the window latch, but with Plexiglas windows we will have to create some sort of breakaway section that can be reset each performance. Unfortunately, the window sashes that we found in stock are much smaller than I remembered from the *Rent* build. This means a much harder construction process while I try to figure out how to make the small sashes fit.

October 18, 2012

The casters arrived yesterday afternoon, which means we can finally get started on the big platform for the apartment. Hopefully, the assembly of this wagon will go smoothly and we can get walls up before Monday. The coffin locks that we installed on the stock platforms should make the process faster. We're finishing the remaining flats, including the nightclub flat. This one gave us some problems with inaccurate construction causing the seams on the skin to be unsupported. After examining the frame, the discrepancies were unacceptable, and we will have to rebuild the frame more carefully. I consider this a failure on my part, since I should have been double checking everything and making sure that mistakes of this kind are caught before they become significant.

October 19, 2012

We have finished building most of the walls, so now we are moving on to spackle and paint. The apartment platform was finished this morning; however, we have run into a slight problem with the coffin locks. One set of platforms has a gap between them that makes it impossible for the cams to finish locking. To solve this, I have had the lid taken off and a bolt run through the framing for those two platforms. Since we had a finished platform, our next step was logically to get the walls up. This process went as smoothly as possible, and by the end of the day, we had the skeleton of the apartment finished. We will continue with the remaining flats and with the office walls next week. I am pleased with the progress made this week and hope that next week proves to be just as productive.

October 22, 2012

With the major element of the apartment finished, this week we are trying to finish the remaining walls and get some of the detail work finished. The desk, the banquettes and the office walls are significant pieces that the director would like to have for rehearsal, so they are on the top of the list. We have a few walls left to finish the framing on, though the night club wall has been rebuilt. In terms of paint and spackle, this week is the time to start, since we are down to two weeks before first technical rehearsal. The banquettes are going to be a challenge to build, and to that end, I focused on getting the drafting done over the weekend. We had made some

good progress by the end of the day, with one of the banquette bases framed and the other in the works. The backs are going to be difficult, but I feel I have put the right people on the problem and am confident that the banquettes will be finished with plenty of time to spare.

October 23, 2012

I worked all day today, but we made some major progress. We got the office walls finished and skinned, though we were not able to get started on getting them attached to their platforms. The deck for the apartment was finished with sound board and Masonite followed by a base coat of paint today, helping to control the sound of the actors walking on it. We also finished the banquette bases, making the completed units for Friday a real possibility. We also started to spackle the seams on all of the walls. It was a very humid day, which did not help. The spackle was drying very slowly, which unfortunately pushed paint on the nightclub back a day. I did have a good find today. We went down into door storage to find the doors that we want for the apartment, and I managed to find the sashes from *Rent*, which solved all of our problems with the window. We also moved the window down 12" in order to make it easier for the actor to climb through.

October 24, 2012

I made another supply run today. I needed more material for trim and a door for the listening booth. I wasn't able to find a bi-fold door in the right dimensions, or with windows, so I bought one at the right width and had it modified to fit the needs of the show. We also dug all of the framing from the *A Chorus Line* false proscenium out of the dumpster and cleaned it in order to build the shelving unit for the record shop. The window gave us a bit of trouble today. After installation, the mobile sash will only open about halfway. There's not enough room for the actor to get through, so I am brainstorming some solutions. I have considered plastic between the sashes to smooth out the action, but I think that might be more trouble than it is worth. We are continuing to build the remaining pieces as we get closer to technical rehearsals.

October 25, 2012

The window problem proved to be much easier to fix than originally anticipated. I swapped the sashes and the window works perfectly. Apparently, one of the sashes is slightly warped, and this warp was causing it to jam against the other sash. Making the warped sash the stationary one fixed the jamming problem. We continue to work on the walls, and finally got the nightclub wall flown. There's one seam that looks a bit lumpy, but several conversations with Files have suggested that there is not much to be done about it now that the paint is finished and the wall hung. It would have been nice to have that seam looking better; unfortunately the problem seems to be in the framing,

and not in the spackle. The seam is a problem, and one I should have caught before the wall was painted and flown.

October 26, 2012

With only one more week before first technical rehearsal, I think we're in pretty good shape. There are still a few things left to finish, but all the major set pieces have been started. We have the designer run this weekend, which I plan to attend. I'm hoping that watching the actors will give me a better idea of what needs to be finished earlier in the coming week. Paint has also become a significant issue as we approach the first technical rehearsal. There are a lot of patterns and other details that need skilled staff on. Files has been working closely with Naoko Skala, a design graduate student who works in the paint shop, to work out what needs to happen and prepping stencils and other needs for the next week.

October 29, 2012

The last week before first technical rehearsal is always a challenge. I have a long list of notes from the designer run which suggest that there's more to do than there really is. There are a lot of minor details that need only one or two people to complete. Most significantly, I need to make a decision about how to stabilize the apartment walls. A two by four was installed temporarily on one side, but the walls need more than that. There are still several jacks left over from *Altar Boyz* that are more than tall enough. I

will have someone modify them to fit on both walls, thus providing the needed support with a much smaller profile than 2x4. The new jacks should be run by the designer and director to make sure that the visual impact is as small as possible. We have also been struggling with the oven doors, which have a central panel that fell out, but the steel is so thin that welding it to the cast iron frame is very difficult. This will need further experimentation. Perhaps an epoxy like JB Weld will be enough to hold the plate in.

October 31, 2012

We got the door flat for the record shop built, but it looks terrible, and we ran out of brick for it. Something I had not taken into account when ordering the brick facing was the difficulties involved with lining up the pattern. With the apartment wall finished, there was not enough large scrap from the new brick left to finish, and the brick left from *Rent* was the wrong color. I'll try to get away to buy more, but the record shop may not have a working door for first technical rehearsal, or I'll have to stay late and get it done outside normal shop hours. The JB Weld on the oven doors was ineffective. The panel popped out as soon as any pressure was put on it from the other side. I think there might have been too much rust on the cast iron for a good bond. A wire brush and more epoxy should help.

November 1, 2012

The apartment is nearly finished. There are a few details left to hang, but the majority of the paint is done and furniture is installed. The office walls are assembled and sitting on their respective wagons, but they have only been base coated. The wallpaper pattern is a complex system of circles in two different shades of green. These walls are going to take time, and skilled labor to finish the paint. The desk is looking good, as are the banquettes. The nightclub wall has been done for a while, which has been nice since the stage is clearer. While we are not quite ready for first technical rehearsal, we will be by the end of the work day tomorrow. I'm very happy about coming to the end of this build as it has been somewhat more stressful than past sets. The extra stress from this set build most likely comes from two major sources. The urge to create a polished set that showcases my growth as an artist and a technical director has caused me to be more stringent with myself over the construction process. Secondly, the fact that this is my final technical direction project has put more pressure on me to do well. As the set is finished, the sense of relief has been growing stronger since I know that soon, all this will be over but for the writing.

November 2, 2012

Clearly, the bracing on the door wall of the apartment is not sufficient. My list from rehearsal is quite long, but not insurmountable. I'll have to see what I can get done tomorrow when I come in to get a few things done before our second technical

rehearsal. We still don't have the doors on the oven, and I don't think they will be there before Monday. There's plenty of painting left to do, but I feel confident that the majority of the construction is done.

November 3, 2012

Files and I came in before the rehearsal to get a few things done. The record shop door hadn't gotten hung yesterday, so I hung it and we got the apartment trim up. The ogee routing bit, used to cut s-shaped curves, from the shop hit a screw while I had one of the shop staff cutting trim, chipping the blades and making the bit essentially useless, another mistake that I could have avoided with more careful attention to detail. I knew the screw was there, but had not taken the time to remove it when I should have. I went out and bought a new one. The size is not quite the same, but we have enough of the original to avoid having a seam between the two separate sizes. Files and I were able to finish the trim in the apartment, but there is still plenty of work for the coming week.

November 4, 2012

Rehearsal went well, but Files and Finocchiaro have decided that the large steel jacks are simply too disruptive to sight lines. I have added finding an alternate solution to my list. We are also changing the baseboard in the office from foam to lauan, which should make it more durable during scene shifts. On the plus side, the existing trim will



be recycled as trim for the desk. The stage hands are steadily getting better at shifting the scenery. The front apartment door is having problems. When the hallway platform is in place, the door will not open all the way, which impedes the actors trying to go through the door in a hurry. The stage manager also pointed out that the bottom hinge has broken through the framing. I'm not sure how to fix it without rebuilding the flat, so it may just have to stay that way through the run since the door works without that hinge attached. My best guess, the flexing in the wall caused by the doors opening and closing caused the screws holding the hinge to wiggle, breaking out the back of the framing member.

November 5, 2012

We got a huge amount accomplished today. The oven doors are still giving us problems, but we should have that solved before we open Thursday. In order to fix the jacks for the apartment, we have replaced the large jacks with much smaller ones, and reinforced the back of the door flat with a 2x6 on edge, bolted into the frame of the platform. I am also planning on adding an L-brace along the top, just over the doors on the back of the wall. We have also made another L-bracket out of 1" square tube steel, which will be placed behind the set dressing in between the doors. This should help resist the movement we have been seeing when the actor pounds on the wall. The extensive list I wrote during last night's rehearsal is down to two items that need more

attention. This is very exciting since it bodes well for being fully done by Major's Preview.

November 6, 2012

Today was as good as yesterday. Today's to do list was as long as yesterday's, and we managed to get everything on it done. The oven doors are working, as well as a plate behind the burner knobs installed. I'm still having some problems with the front door, but I think lowering the hall platform will solve the issue. We finished the trim for the record shop, and finally found a ladder that will work for the actor. For tomorrow, we are finishing paint. This has been an exhausting build, but very exciting for us to be so close to finishing this complex set.

November 7, 2012

My notes from last night were minimal. Everything that needed attention was paint except for one thing to fix. Someone damaged the Masonite facing on one of the banquettes, so it needed to be replaced. The chain and latch on the apartment door also got reversed. I'm not used to these types of latches, so when it was installed, it got installed backwards on my instructions. I'm looking forward to the calm between opening night and strike since I can finally catch up on my writing and my homework. This was undoubtedly my most challenging build, but it went very well; however the budget got out of hand. My budget overage stemmed from a number of sources. The

first was my need for casters beyond what we had available in stock and the hidden costs behind putting casters on so much of the set. Each caster required four lag screws, and we ended up using approximately 90 casters which cost around \$24 apiece. This required a grand total of 360 lag screws. Aside from the casters, I had some trouble estimating the material needs of the show because of several outside factors that reduced my available time, resulting in several supply trips as well as several replacement tools which were damaged. Lastly, I feel that the set was probably inherently more expensive than the budget would have allowed for given the way I had things built. I did not have a lot of extra stock lumber, which resulted in purchasing a significant amount of new wood, and there were some specialty materials that could have been substituted for cheaper methods, such as the brick, which could have been a paint treatment instead of a three dimensional facade.

#### November 18, 2012 Strike

This afternoon, we struck the show. Breaking down the crews was based on set pieces, though I did have to account for the nightclub wall, since it couldn't be struck while the stage was full of other set pieces. I was very pleased with how well everything went. There were no accidents, and everything was taken down within the two hours. I feel that the success of this strike was due to the effectiveness of the crew heads, who were able to keep the crews on task and maintain efficiency in the demolition process even with the number of people who attended. Additionally, there was some front end

planning that expedited the deconstruction, namely clearing space in the shop which allowed for some of the smaller set pieces to be taken apart off-stage, and the mobility of each unit made moving them around the stage as needed easy. The strike sheets also included a list of instructions, which allowed the crew heads to minimize their need for direct instruction from the technical director. Since they were able to stay directly in contact with their crews, less time was wasted walking around looking for the technical director to ask questions.

Finally, this production pushed my skills in management, construction techniques and my ability to handle when things went very wrong. Several flats required some significant rebuilding, which took time. Ultimately this was, as ever, a learning experience that will help me grow as an artist, as an engineer and as a manager.

## CHAPTER 4

### POST-PRODUCTION ANALYSIS

*Cactus Flower* was produced at Minnesota State University, Mankato, and performed on the Ted Paul stage on November 8<sup>th</sup> through the 10<sup>th</sup>, and the 15<sup>th</sup> through the 18<sup>th</sup> 2012. The process of building the set was a critical step in the technical director's learning experience and growth as an artist. *Cactus Flower* required significantly different skills than any previous set that Technical Director Andrew Lopez had built, having multiple locations and moving set pieces. Set designer Noah Files expressed his satisfaction with the final product, but getting there proved more challenging than initially anticipated.

Files' design called for wagons to provide the scenery for each scene, which allowed the sets to remain mobile for quick changes, but complicated the build process since every set piece built either had to be on casters, or light enough to be carried on and off stage. Each of the four major locations in the show presented its own unique set of challenges, and required ingenuity, persistence and most importantly, the assistance of a dedicated design team and the shop staff.

The apartment unit consisted of a sixteen foot square wagon, with twelve foot walls on the upstage edges. These walls needed to have functioning doors, as well as a working window to fulfill the needs of the script. Additionally, the stage left wall

needed to be two sided, with the other side being the record shop wall, and it needed to have platforms that could attach behind the doors and the window providing a hallway and a fire escape. These external wagons needed to be removable, as well as close to the same height as the main wagon.

The first problem to solve was the difficulty inherent in assembling a sixteen foot square platform on casters. The procedure used in the Minnesota State, Mankato shop is to caster a platform is to flip the platform, install the casters, and then return it to an upright position on the casters. This works only when the wagon to be flipped is small enough and, most critically, does not have a structural weakness that could fracture during the change in position. Lopez originally decided to use coffin locks, two piece metal locks that are held together by a cam, to securely fasten the individual four foot by eight foot wagons together once they had casters. This solution would have provided the easiest assembly and disassembly, but required each platform to have at least four coffin locks attached. Since the shop does not routinely install coffin locks during platform construction, every platform used would have to be modified. This would take a significant amount of time as well as presenting the possibility of the locks not lining up properly. Files offered an alternative solution that turned out to work just as well, and required fewer coffin locks. Rather than install coffin locks on all of the platforms for the larger wagon, we instead only installed them on the ends of the platforms, allowing assembly of two eight by sixteen platforms with bolts through the framing. The coffin locks would then attach the two sides together into the full sixteen

foot by sixteen foot wagon. This assembly process would eliminate the need to flip the full size wagon, which would require a significant number of people. It would also remove the center seam which would be parallel to the floor as a factor, since that seam would not exist until the whole platform was assembled. The shear forces on this seam could cause the screws holding the platform frame together to tear out, resulting in collapse and potential injury to shop staff.

The wagon construction went smoothly, but for one set of platforms where the coffin locks were too far apart for the cam to properly lock, a problem solved by removing the lid, bolting through the frame where the coffin lock couldn't reach, and putting the lid back in place. Lopez chose not to use this method for the full assembly because the casters are attached to the bottom of the platform lid, which would cause the frame to fall down once the lid was removed. Decking the wagon with sound board and Masonite happened after the walls were installed in order to keep the walls more stable. Sound board is a compressible material, which can adversely affect the stability of the walls, a problem that would exist anyway given the configuration of the apartment unit. Each wall for the apartment wagon were built as three separate flats which were then screwed together. Lopez wanted to use this method to keep the seams between the flats as nice looking as possible while using a minimum amount of spackle. Flat construction for the apartment was not difficult, and was completed quickly; however surface finish for the stage left side took longer than expected due to a problem with getting the brick facing from Menards. The technical director had

included sheets of brick façade from Menard's in one of his supply orders, but due to misplaced paperwork by Menard's, the order was lost for almost a week. Despite several phone calls, Lopez eventually had to simply pick up the missing material in order to finish the flat in question.

The one significant challenge with the flats for the apartment was stabilizing them without the ability to install jacks behind the flats. Files and Lopez discussed this problem several times without a satisfactory solution. As the first technical rehearsal grew closer, Lopez began to experiment with several ideas. The first attempt was to install large steel jacks on either side, which interfered with sightlines too much. The second attempt replaced the large jacks with much smaller ones that helped reinforce the walls, but the jack on the door flat was insufficient to prevent the wall from shaking and leaning when the doors were opened or closed and when the actors were required to pound on the wall. The solution was to reinforce the section of the wall between the doors with a two by six on edge running up the framing and bolted into the platform, as well as a shop built steel L bracket on the front of the wall hidden behind set dressing. Both of these braces improved the stiffness of the wall, resisting the shake. The other wall required much less reinforcement since it never had to stand up to the abuse of the first.

While reinforcing the window flat was a simple matter, installing the window was a much more difficult process. Files wished to use the window sashes from a previous production of *Rent* since the size would work and the window needed to be



functional. The *Rent* sashes were discovered in door storage when a group went down to pull doors for the apartment. Finding the proper sashes made installing the window less complicated, and once it was working properly, the actors were able to use it during rehearsal. Additionally, Files decided to move the window down 12 inches after the wall was assembled and erected. This change would result in problems with the listening booth for the record shop, but was easy to execute.

The doors for the apartment were challenging, but not overwhelmingly so. One of the most challenging things was getting the apartment front door (the door furthest upstage) to open all the way while the hallway platform was in place. The bottom of the door would scrape on the platform, which caused it to jam before it was fully open. Lopez tried several solutions, from making the door shorter to dropping the platform in small increments. The only thing that finally worked was to completely remove the caster plates, which made the hallway platform almost 3/4" shorter than the apartment platform. This allowed the door full range of movement, and the actors were able to avoid tripping on the lip caused by the change in height. It helped that the change happened at the threshold of the door, which most people step over anyway.

The record shop build encountered several difficulties, the most difficult being the delay caused by the missing brick. This set required a door/shelf unit that was free to move on its own, but the door flat for the unit needed to have brick on it to match the rest of the walls. Without the brick to build the wall, Lopez kept delaying starting on that wall. The delay almost caused problems for tech rehearsals, since the actors would

have been rehearsing without that wall in place. Aside from the delay, the wall itself presented a few problems. First, the wall needed a door but was only supported on one side. This caused the unsupported side to shake every time the door was slammed, which happened with some frequency. This problem was never satisfactorily solved because of the way that the set piece was constructed left no room for a supporting jack, but with some practice, the actors got better about being gentle with that door. The record shop door wall and shelf connected together by a series of triangular blocks screwed into the framing which held the two separate units at the appropriate angle to each other. The whole doorframe/shelf was also on casters, but proved to be self-supporting once finished. There were no significant problems with assembling this section.

Files decided to use a listening booth to cover the apartment window for any scene in the record shop, thus differentiating the space from the apartment. This booth went through several iterations, finally resulting in a booth that was eight feet tall sitting on yet another wagon approximately four feet by two feet. The final booth was 12 inches shorter than the original concept, and the window sill was also lowered by 12 inches. Constructing the booth was fairly simple, even with a bi-fold closet door to install. However, with all of the changes that occurred between concept and construction, the booth ended up about eight inches too short to cover the window. This problem was solved by Files, who designed a sign to install on top of the booth that

would cover the window, but remain with the booth when it was not on stage; a simple, elegant solution to a problem.

The record racks were the first set piece to be constructed. The assembly process required some experimentation to get right, however once figured out while building the first of three, the other two came together much more quickly. The materials used made the racks heavy and awkward to move by one person even with two casters on one end. One rack was fitted with four casters, but the loss of stability combined with a lack of any way to keep the racks from moving once on spike, the decision was made to keep the two wheeled design.

The dentist's office set, since it was simply two walls, a desk, a sofa and a coffee table, was probably the simplest to build. The walls presented a challenge, however, since Files designed the walls to have angled tops over the entire length. Lopez decided to build the walls as individual flats, like the apartment walls, but rather than assemble on the floor and then raise the walls, he decided to have them raised as separate pieces that would then screw together once up. He decided to do this in order to minimize the seams, since these walls would be much less decorated. While the seams lined up well enough at the bottom of the flats, the tops would not meet without putting undue strain on the framing. There were gaps, as much as 1/2" between the tops. Fortunately, these gaps were able to be covered with the trim, but a better solution would have been to assemble the walls whole, and then mount them on their wagons. There were no other significant challenges with the dentist's office.

The night club was the set with the fewest components, but with round banquettes and a flown wall, proved to be a trickier build than the office. The banquettes required custom framing and attention to detail to get the right look. The wall, a sixteen foot square flat with a five foot by eight foot opening in the bottom center, required a different construction method than the more traditional construction of the smaller walls for the other sets. Because this flat was to be a flown unit, Lopez decided to build it as a single oversized flat as opposed to several smaller flats attached together in order to improve the structural integrity of the unit. To this end, Lopez purchased lumber long enough to span the height and width, and then used 2x4 framing for all the seams. This construction design was heavier than a 1x4 framed flat, but it provided a much stronger structure that would withstand the stresses present in flying a flat. Once the flat was built, painted and had the hardware installed, flying it was a remarkably smooth process. Holes were drilled in the framing to run 1/8" 7x19 aircraft cable through a hanging plate bolted to the bottom of the frame in four places. The cables were attached to the batten with trim chain, and shackled into the flat with turnbuckles, thus allowing the flat to be leveled to the floor. With the arbor reweighted to counter the weight of the flat and the stage cleared, the process of getting the flat into the air took only a few minutes.

The banquettes for the nightclub were possibly the most complex piece of furniture in the show. Files designed them with a circular base with a back that curved up from the front. The complexity of the design required a strong construction design

to support Files' initial vision, while still remaining relatively easy to construct. The circular base, at six feet in diameter, required two pieces cut to make the deck of the platform. In order to keep even support around the edge without bending wood, the framing was designed as a 12 sided polygon with internal framing to support the joints in the deck. The back was also framed from 2x4 with 1/4" lauan bent around the outside of the circle. The seat of the banquettes was made from short frames with an upholstered section of 3/4" oriented strand board, OSB, simply sitting on top. The simplicity of the construction helped to speed up the process, which resulted in both banquettes being built within two days. The nightclub set came together very quickly, only suffering delays from paint. Everything for this set worked quite well, with the only ongoing problem being the stage brakes on the banquettes. The placement of the brakes caused some of the lag screws holding the brakes in place to pull out of the lauan, since the brakes were placed where there was no framing behind the lauan to provide a decent hold for the screws. This problem did not get solved completely, but was partially ameliorated by adjusting the foot on the brakes, and by placing a block inside the lauan skin behind the brake, thus giving the lag screws something to thread into.

Overall, the build for *Cactus Flower* went smoothly, with some problems during the construction process, and a few delays caused by paint, or lack of materials. However, the show was given a budget of \$1250.00, and final costs to build the set ran almost \$600 over that. Part of the budget overage was the purchase of new coffin locks,

and the purchase of over 300 new lag screws. These purchases, however, only account for about a third of the budget overrun. Another part of the budget overage came from less thorough planning than was required. Several additional lumber purchases were made to cover needs that were not originally anticipated, but should have been. Time is a factor when estimating material needs. Lopez did not provide enough time to analyze each set piece as thoroughly as was needed, which caused material shortages. While not catastrophic, planning lumber and other material purchases more carefully could have saved some of the budget overage. Additionally, Lopez had to buy a new ogee router blade after the first was damaged by a screw in part of the lumber set aside to make trim and a new blade cost approximately \$50.00. An ogee bit is used to cut s-shaped curves, which makes the bit large and expensive. The damage to the original router blade made it unacceptable, which required a special trip and more money spent on new tools. This accident could have been avoided with more careful managing of the staff, and being a second set of eyes watching for things like metal in the wood. Finally, the budget overage could have been avoided with a more thorough initial estimate based on the design, which could have revealed that Files' design was more expensive than the budget would allow, thus requiring some modifications. These modifications could have come from either the initial design or through changing construction techniques to allow for less expensive construction. Earlier is always better when design changes need to happen, and with a more accurate estimate earlier in the process, these changes could have been made before problems arose.

Generally speaking, this was a successful set for a complex show. The requirements were above anything Lopez had previously built and while there were some problems, most significantly the budget, everything that the designer wanted was seen on stage. This was a wonderful learning experience for Lopez, giving him the opportunity to build a multi-set show and helping him learn from mistakes made. Future sets will be better planned and more carefully budgeted, thus avoiding many of the difficulties that arose from *Cactus Flower*.

## CHAPTER 5

### PROCESS DEVELOPMENT

Lawrence Andrew Lopez began his career at Minnesota State University, Mankato in August of 2010. He entered as a candidate for Masters of Fine Arts in technical direction, a degree that he is pursuing in order to teach at the college level. His ultimate goal is to hold a teaching position in a college theatre department that will allow him to both teach classes and create theatre within an educational environment.

Lopez has taken all of the major design classes; scenic, costume, lighting and sound design in order to better understand how designers work, a process so critical to his own. He has also taken academic courses such as History of Theatre and Theatre Theory and Criticism to better understand the larger context that theatre operates within. He has also worked six semesters in the scene shop as a graduate assistant and worked with several talented individuals who have helped shape his growth as a technical director. This chapter will examine his growth through these sources of instruction and inspiration, reporting how each one illuminated a portion of the process of creating theatre, and how each different aspect ties into the whole.

In his first semester, Lopez took both sound design and scenic design. Scenic design is the closest to technical direction in that it deals directly with the creation of the set and the scenic designer and technical director work very closely together to



realize the design on the stage. The class offered a close look at the process behind designing sets and scenery, from the initial idea to the research behind the set and finally how to draft for the technical director. The largest benefit that this class provided for Lopez was an intimate understanding of exactly what the designer does, specifically the research and time spent to create a set that not only works for the play in question, but also is aesthetically appropriate. Historical research, as well as an understanding of the evolution of architecture helps the scenic designer to create sets that are accurate. However, the important part of scenic design for a technical director is where the two parts interact, the drafting. Lopez came to Minnesota State University, Mankato with a basic knowledge of theatrical drafting; however, the class helped him understand the need for clear drafting as a communication tool that eases the flow of information between the designer and the executor of that design.

Sound design offered the opportunity to learn how to develop music and sound effects that properly support a production. In addition to developing an ear for music, Lopez learned the fundamentals of creating a speaker plot, and how to direct sound reproduction efficiently. The sound designer's speaker plot has the most impact on the technical director's work, and learning how sound reflects and behaves expanded Lopez's knowledge base in how to create a set in such a way as to not interfere with the sound designer's job.

In the spring of 2011, Lopez took lighting design, which gave him the opportunity to explore a different kind of drafting, and to discover the aesthetics behind lighting a

set, as well as how to work with the set to enhance the visual impact of the set designer's work. The most valuable part of this class for Lopez was the opportunity to work hands on with lighting equipment, something that he does infrequently, which helped him explore the changes to lighting technology that continue to affect theatres. This class also offered the opportunity to practice drafting light plots, both by hand and by computer.

Lopez took Drafting for the Theatre and Costume design in the fall of 2011, two more classes that contributed directly to his knowledge and experience in working as a theatre artist. Costume design was probably the hardest class for Lopez to understand. He is used to working with much different materials and techniques. Costumes operate on a different system, requiring a different set of aesthetic skills and knowledge of materials that are frequently significantly different than what Lopez is used to working with. However, the class did offer the opportunity to practice sketching and drawing through weekly assignments and the main projects where he practiced the art of designing costumes.

Drafting for the Theatre was a very valuable class, one where Lopez practiced the art of creating high quality drafting as well as learning the conventions of drafting for theatrical use. His ability to maintain good communication with both his scenic designer and the shop crew depends on the quality of his drawing, and this class improved that ability through new information as well as practice.

In the spring of 2012, Lopez took Styles and Ornamentation as an elective on the basis that a class dealing with architecture and evolving style will inform his later attempts at scenic design. This class provides an overview of the evolution of human style, both east and west, and how the information can be used in the theatre to reproduce specific elements that help reinforce the physical and temporal location of a set. This class provides context for Lopez as he is creating sets according to the designer's requirements as well as the ability to serve the designer's needs through an understanding of the appearance of specific architectural periods.

In the fall of 2012, Lopez took Lighting Design 2, which expanded his working knowledge of the art of lighting a show. While in Lighting Design 1, Lopez focused more on the mechanics of creating a functional design; where to put lights and how to mix color to achieve specific ends. Lighting Design 2 has offered the opportunity to explore the aesthetic of lighting, and to practice designing for a realized production, as he co-designed the lighting for one of the Fall Dance concert pieces.

In the same semester, Lopez took Technical Direction. This class has helped Lopez to deepen and broaden his knowledge of how to realize a set design. Each portion of the class has provided new insights into specific areas, shoring up weak spots while increasing his ability to creatively deal with problems that arise. He has touched on many different areas of technical direction, from budgeting, to shop drawings, to rigging and structural engineering. Each of these areas has provided Lopez with unique

opportunities to become a stronger technical director, a better manager, and a more rounded artist.

In order to fully round out his experiences as an artist within the theatre, in his final semester, spring of 2013, Lopez took Scene Painting, a class which deals directly with the process of painting a set for a production. In this class, Lopez learned how to work with Rosco brand supersaturated paint, and he switched from painting on foam to painting on a muslin flat. He also learned how to create a stencil, and how to research and duplicate various textures for the stage. This class broadened his practical experience, a valuable resource in the future when he begins teaching students how to paint.

Portfolio seminar, taken in the fall of 2010, offered a chance to review the portfolio in preparation for job applications. This class gave the opportunity to expand and refine his portfolio, as well as refine his resume in preparation for job applications post-graduation.

Theatre management occupies the area between practical and academic classes because the information from the class applies to the professional world, but does not directly apply to Lopez's plans since he does not want to run his own theatre. The class provided a valuable understanding of the political side of a theatre. Operating as a professional in the theatre will bring Lopez into contact with the politics that operate a theatre. Rather than operating as part of the steering, Lopez will be part of the machine that makes the theatre go.

Academic courses like Theatre History one and two, Theatre Dramaturgy, Theatre Research and Theory and Criticism do not provide practical experience, but these classes provide context and support for a career in theatre. Without a thorough understanding of where theatre comes from, as well as where it is now as an art form, the artist cannot create good theatre. History informs about the past, about where theatre comes from. Theory and Criticism helps the artist to think about the why of theatre, while Dramaturgy and research help the artist to mesh how and why, informing and reinforcing what is made.

Six semesters as a graduate assistant working in the scene shop provided the opportunity to teach and learn from a myriad of student staff members of varying backgrounds and skill levels. Management is a skill that should be practiced, and the chance to work with a broad group, and to teach new theatre practitioners was critical in helping Lopez develop his ability to work with students. He also used the opportunity to polish his interpersonal relationships with the staff, and to become better at working with personalities that did not mesh easily with his own.

Even more important than working with undergraduate staff, working with other technical directors helped Lopez to become more creative in his solutions, and to respect and listen to the ideas of others. Tom Fagerholm, one of Lopez's classmates, displayed an excellent and creative mind while working in the shop, and through his encouragement and advice, Lopez was able to become more competent at finding good solutions. Fagerholm's management style, one of encouragement and feedback, helped

Lopez change some of the weaknesses in his own. George Grubb, who serves as the technical director for Minnesota State University, Mankato, helped Lopez with endless advice borne from years of professional experience. He also helped Lopez realize when certain problems had become overwhelming, and encouraged Lopez to seek help when he needed it.

Finally, working Highland Summer Theatre in the summer of 2011 provided the opportunity to work in a more professional context and helped teach Lopez how to cooperate with those whose personalities may not mesh well with his own, and to keep a professional attitude towards work and co-workers in spite of difficulties.

All of these classes and his time working with other technical directors and in the scene shop have provided context and knowledge that have helped Lopez to develop a distinctive style of management, and to better inform him of the process of creating good theatre. The course work was intense, the productions many, but in the end, all of these elements combined to provide an unprecedented opportunity for Lopez to expand his skills.

APPENDIX A

WORKING/SHOP DRAWINGS

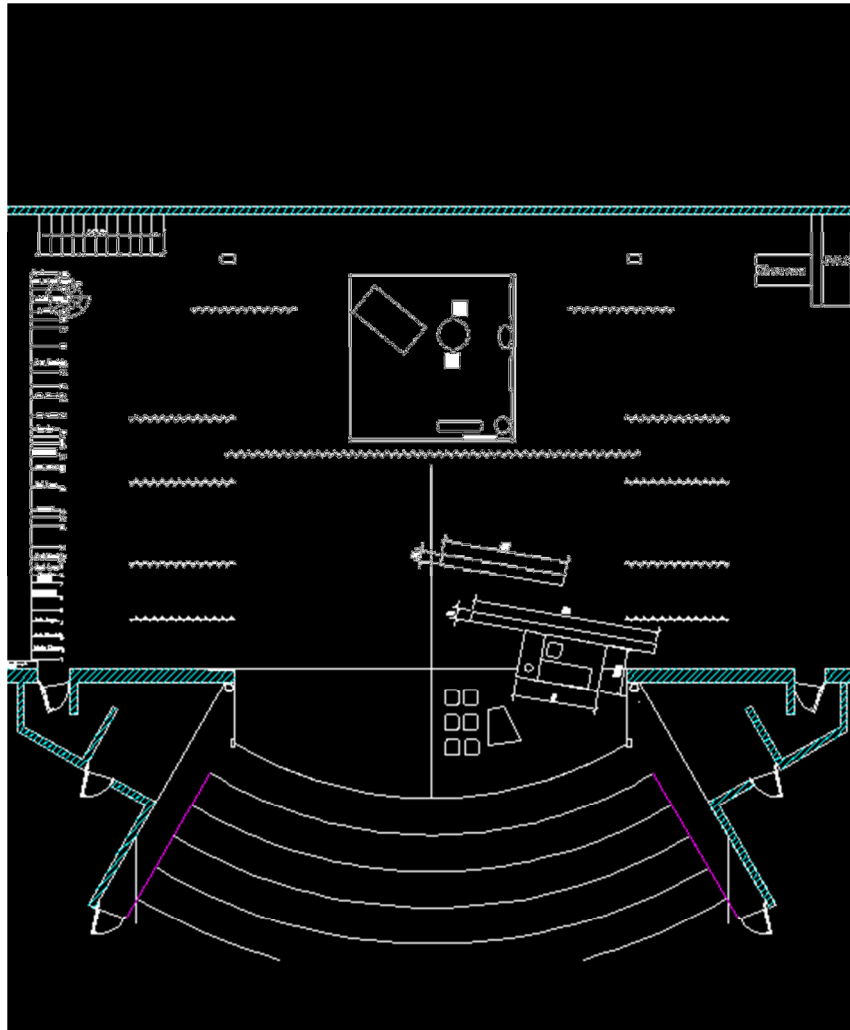

GROUND PLAN FOR DENTIST OFFICE

BY DESIGNER NOAH FILES

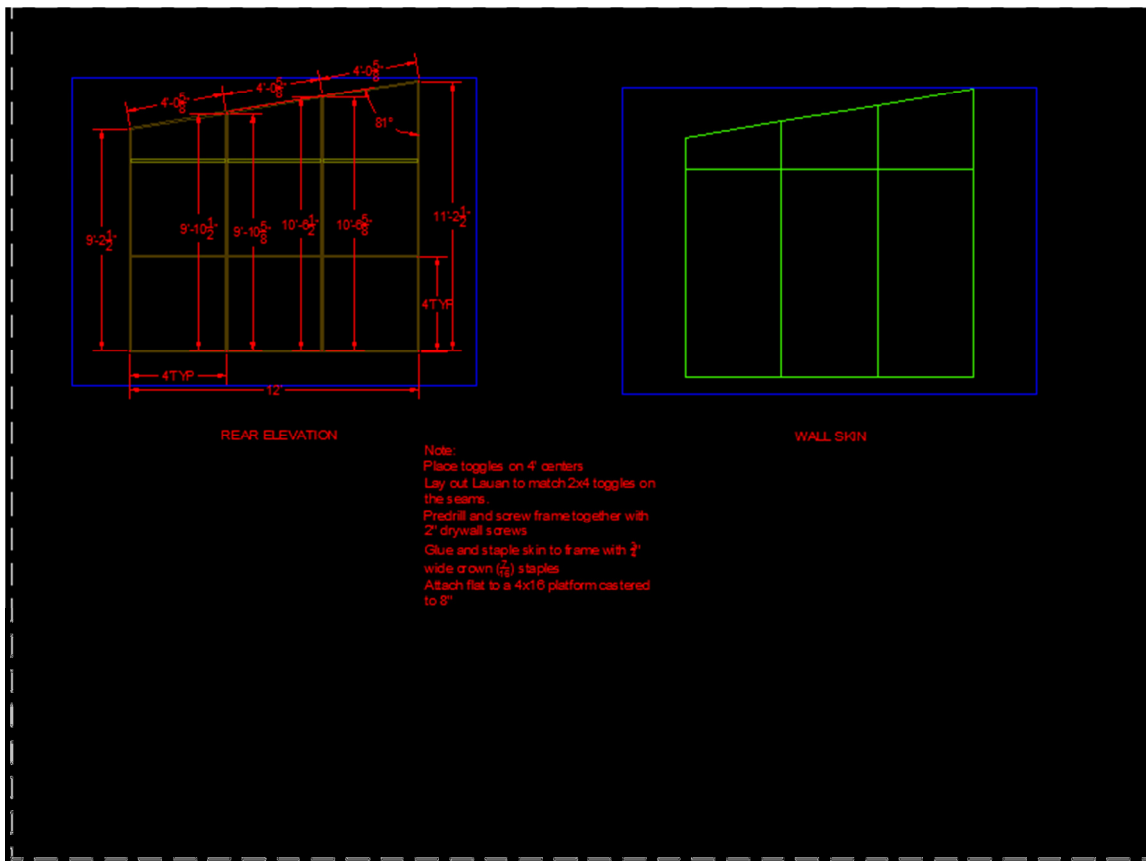

DENTIST OFFICE WALL 1

REAR ELEVATION



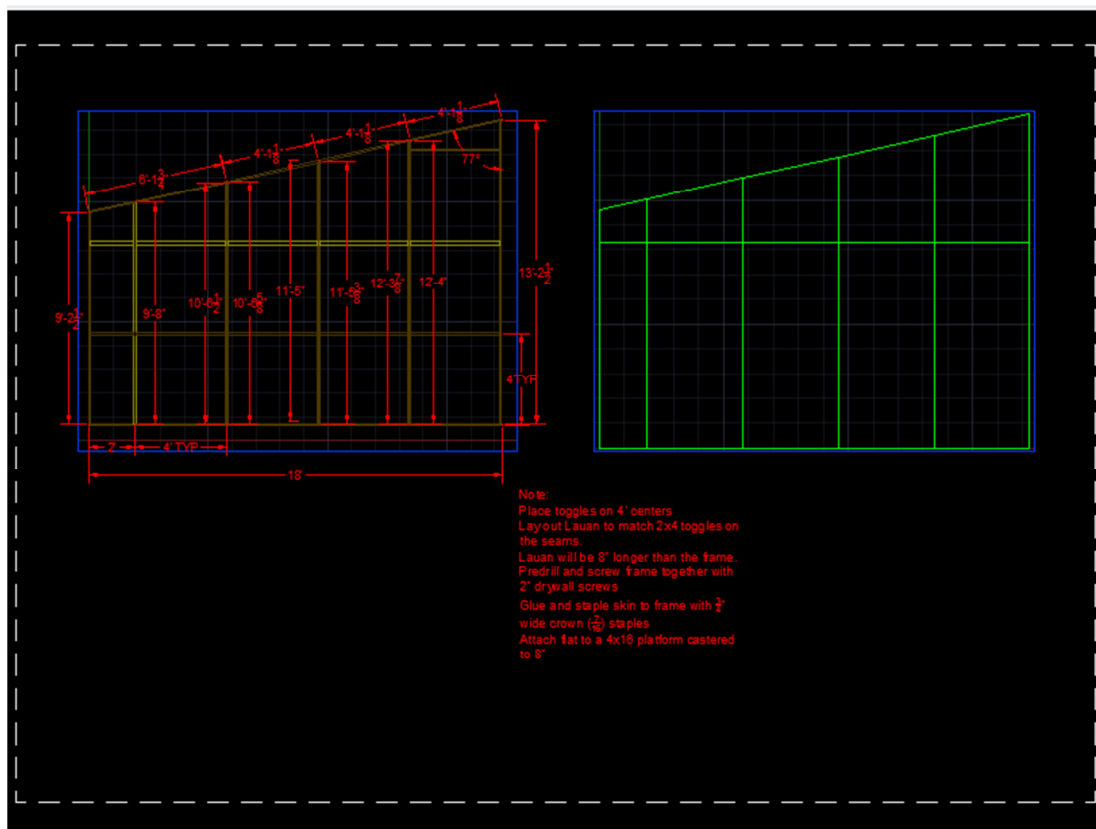

## DENTIST OFFICE WALL 2

## FRONT ELEVATION

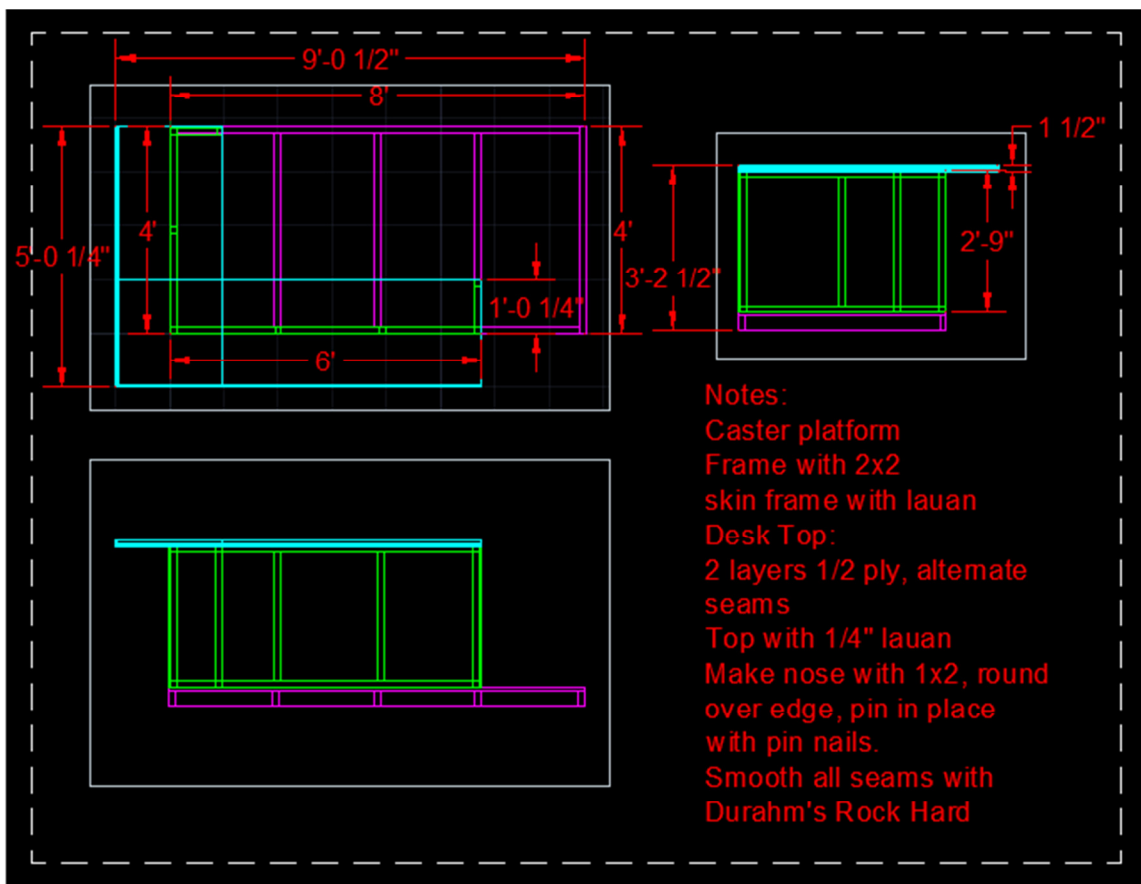

DENTIST OFFICE DESK

SHOP DRAWING

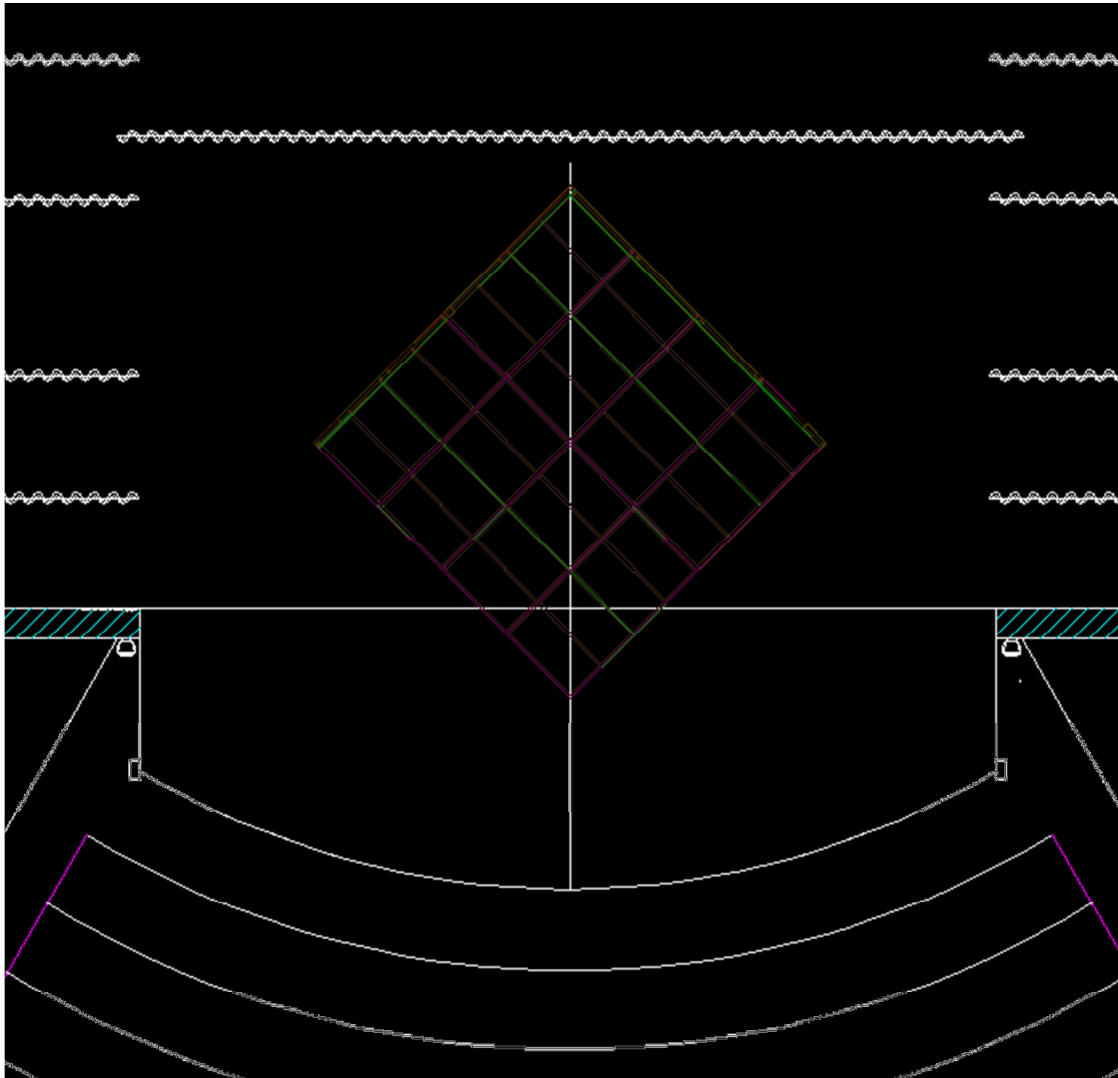

APARTMENT GROUND PLAN

## TO DO TUES. Oct 9<sup>th</sup>

Pull 9 4x8 Platforms

Pull 1 3x6 Platform

Pull 1 Either 3x5 or 4x6 Platform

Clean All Lion Casters Alicia

- wipe off extra Grease ✓

- Dust them off ✓

Cut 20 6"x6" 3/4" Caster Plates ✓

Cut 12 6"x6" 1/2" Caster Plates ✓

Build 2 more Record Cases Joel

- See Drawing

Alicia, ~~Sarah~~, Donovan  
Sarah, Alexa

Modify 8 4x8 Platforms for Coffinlocks

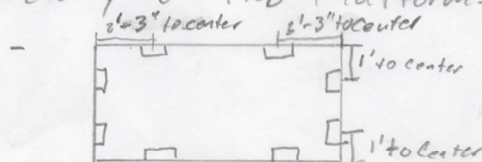

See Sheet

For Placement

- MARK PLATFORMS FOR ORIENTATION

APARTMENT PLATFORM

TO-DO LIST

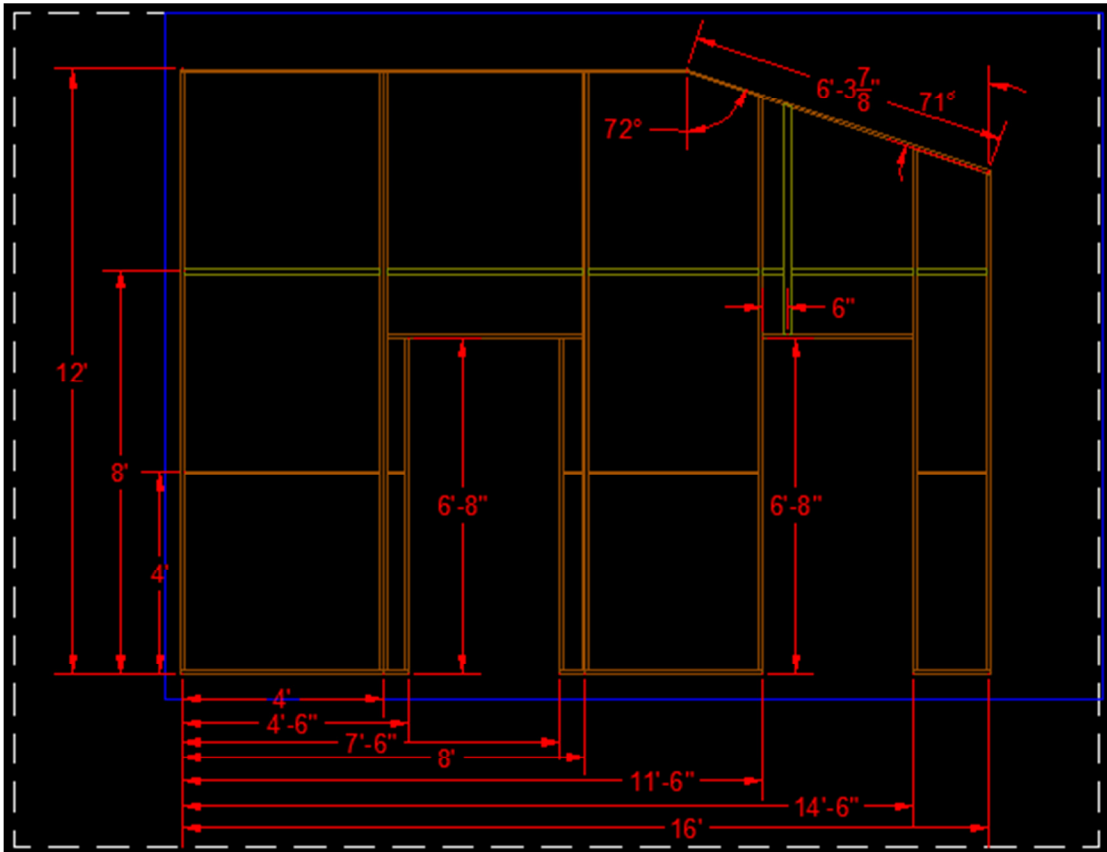

STAGE RIGHT APARTMENT WALL

REAR ELEVATION

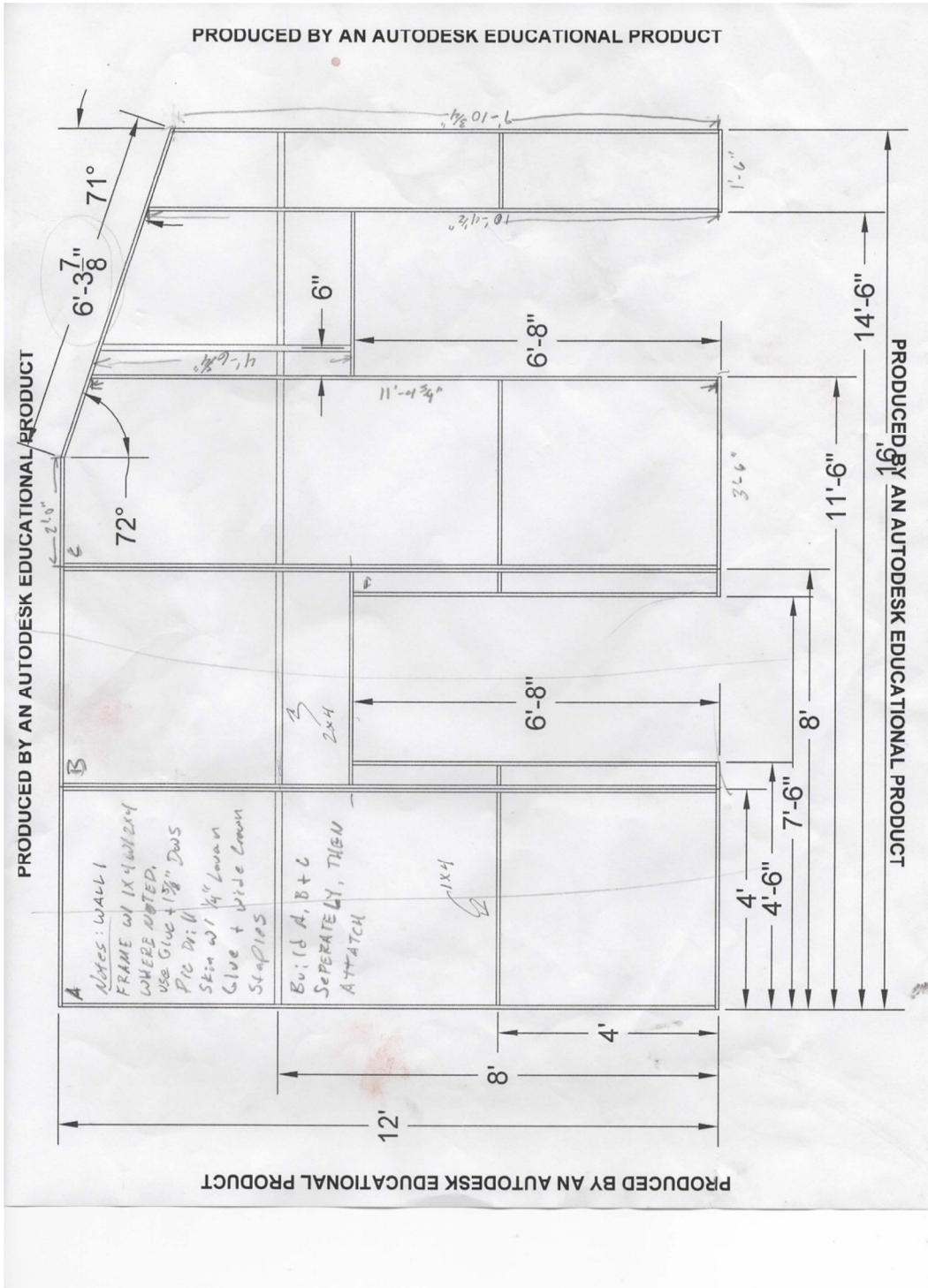

APARTMENT STAGE RIGHT WALL

SHOP DRAWING

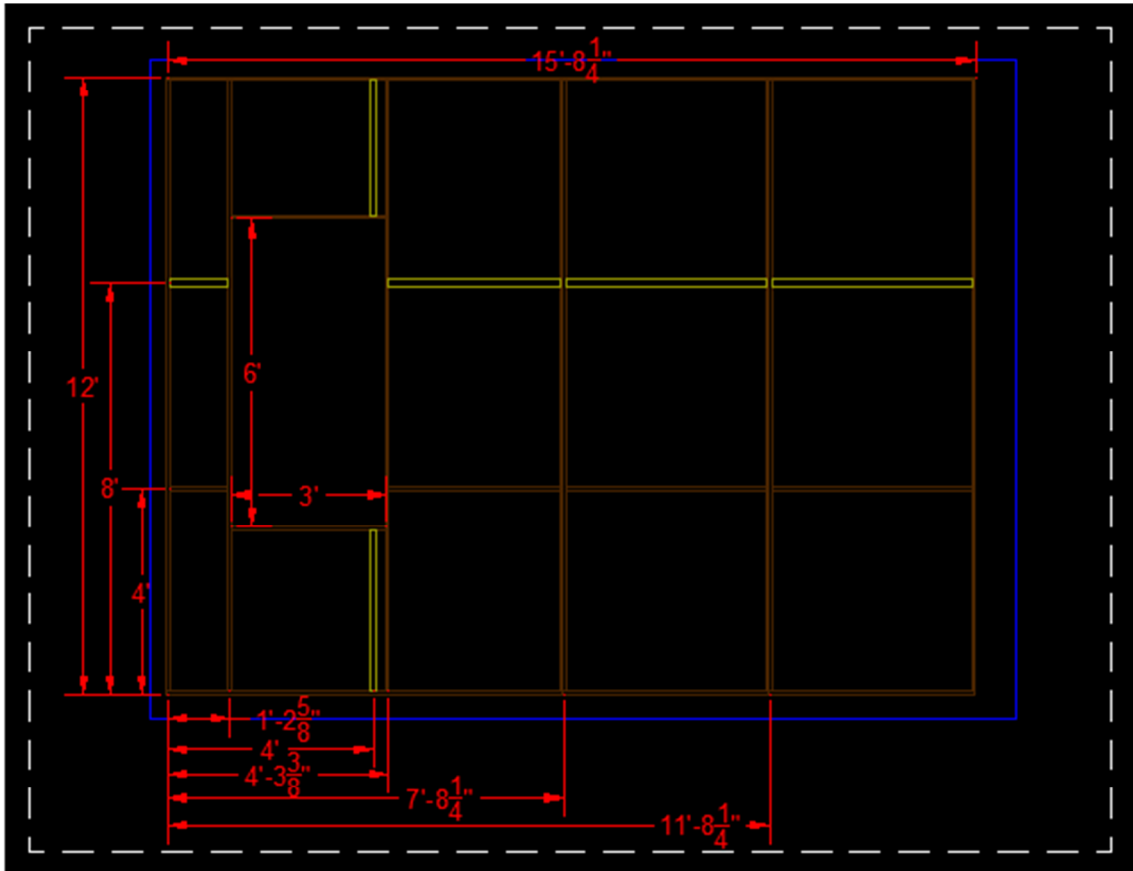

STAGE LEFT APARTMENT WALL

REAR ELEVATION

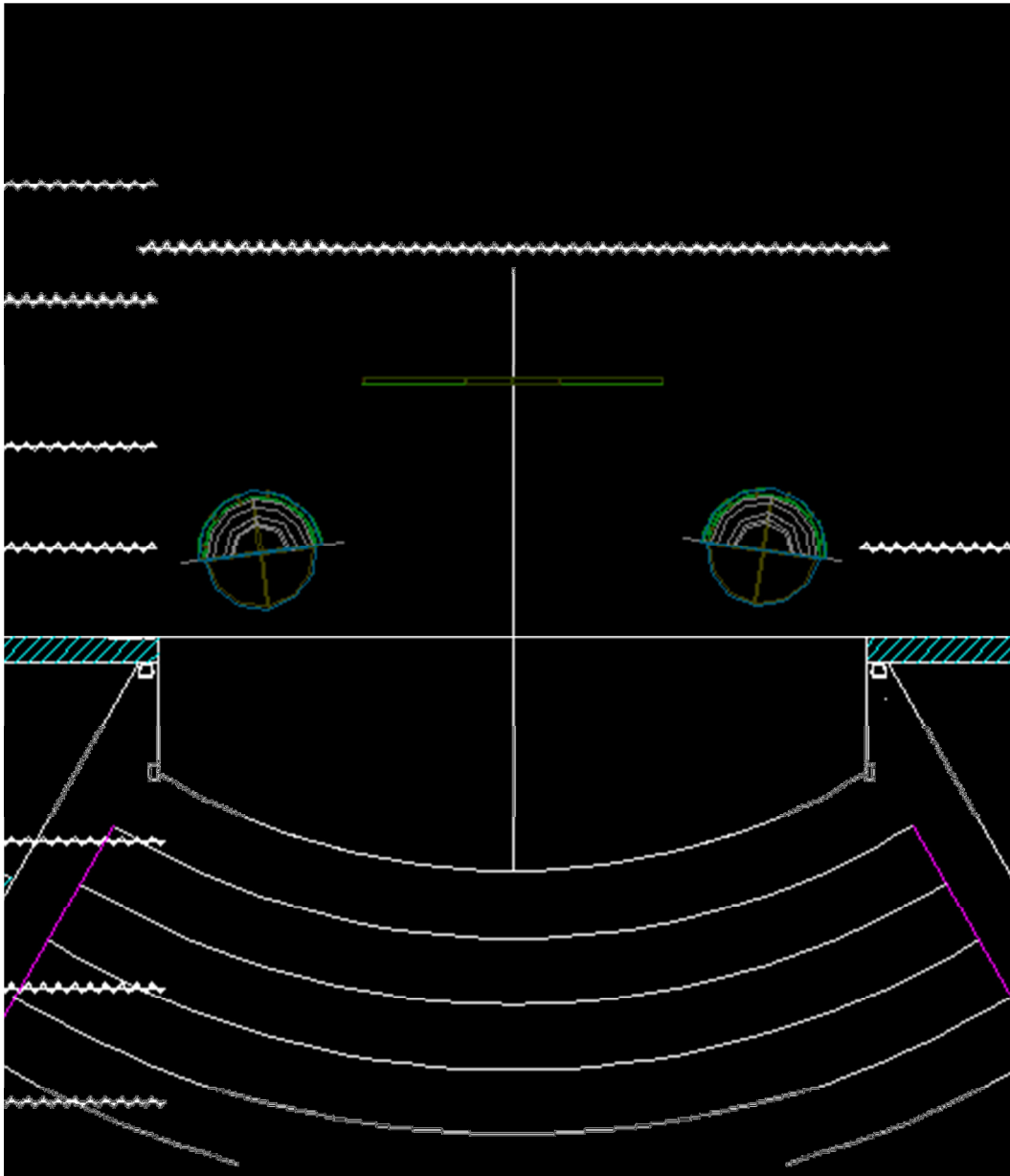

NIGHT CLUB GROUND PLAN



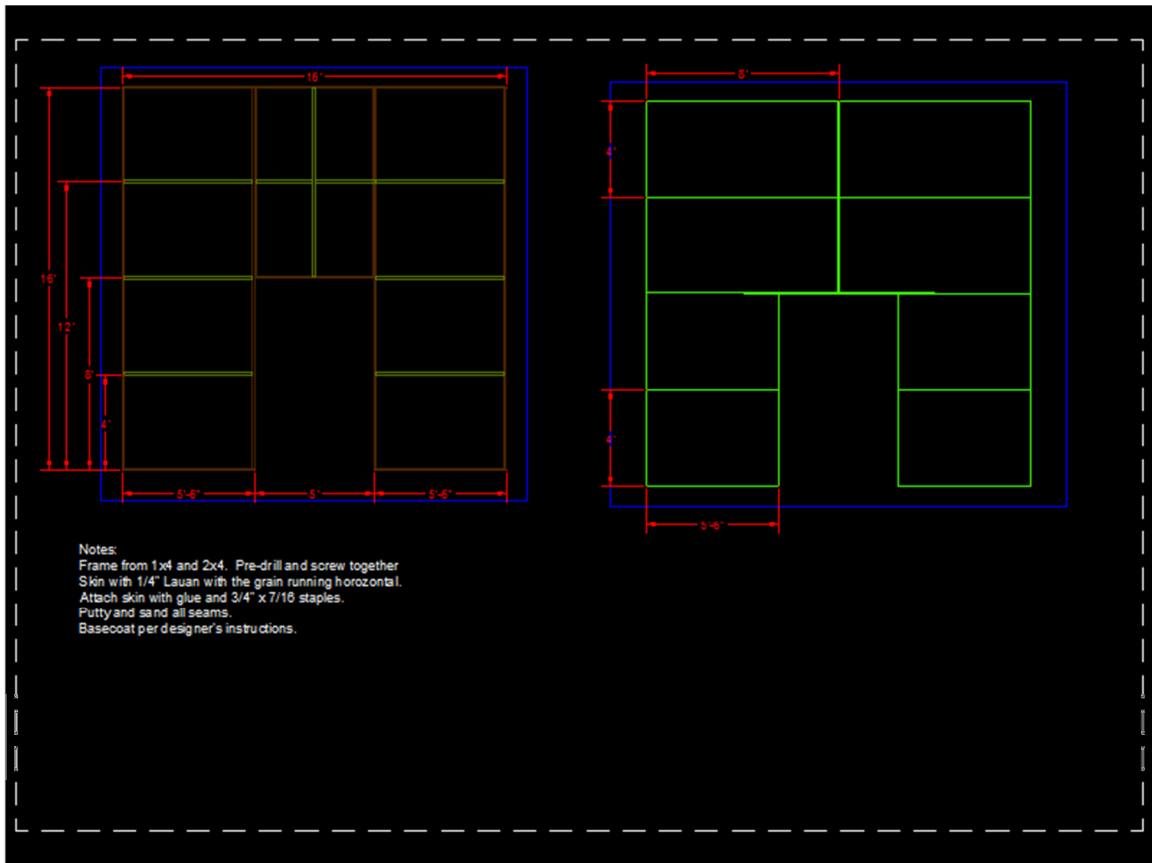

NIGHTCLUB WALL

REAR ELEVATION

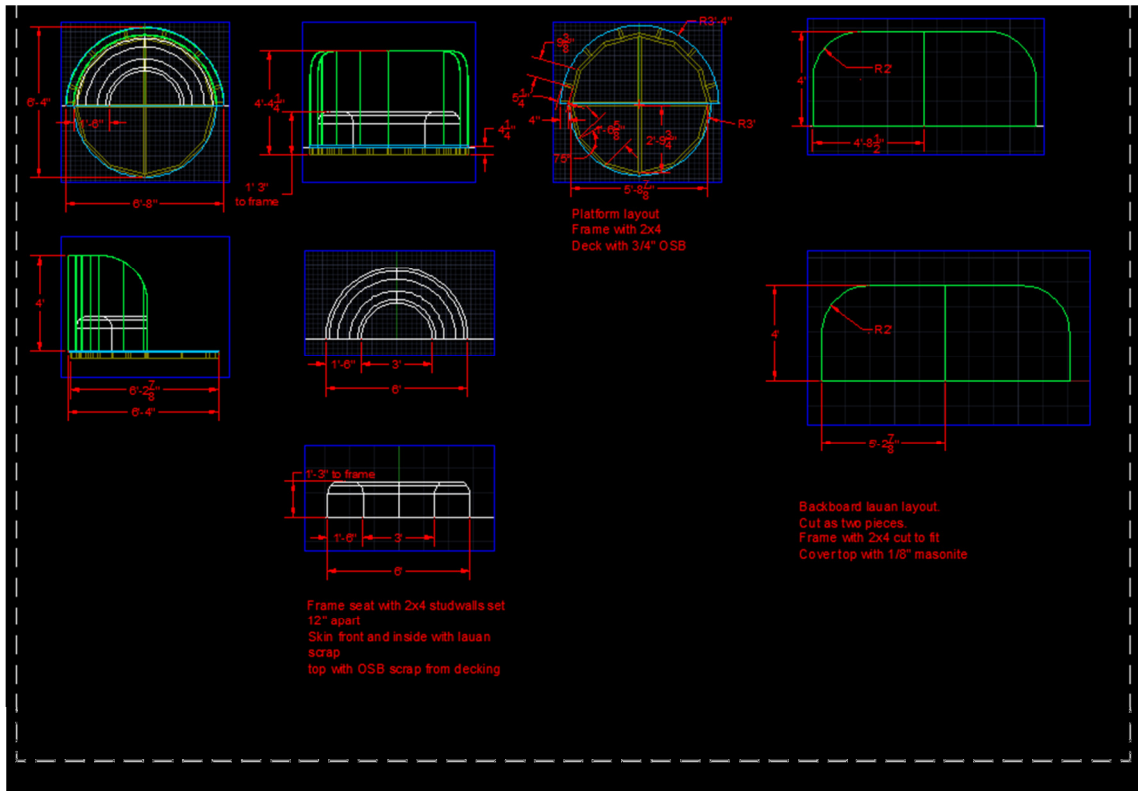

BANQUETTE

ORTHOGRAPHIC PROJECTION

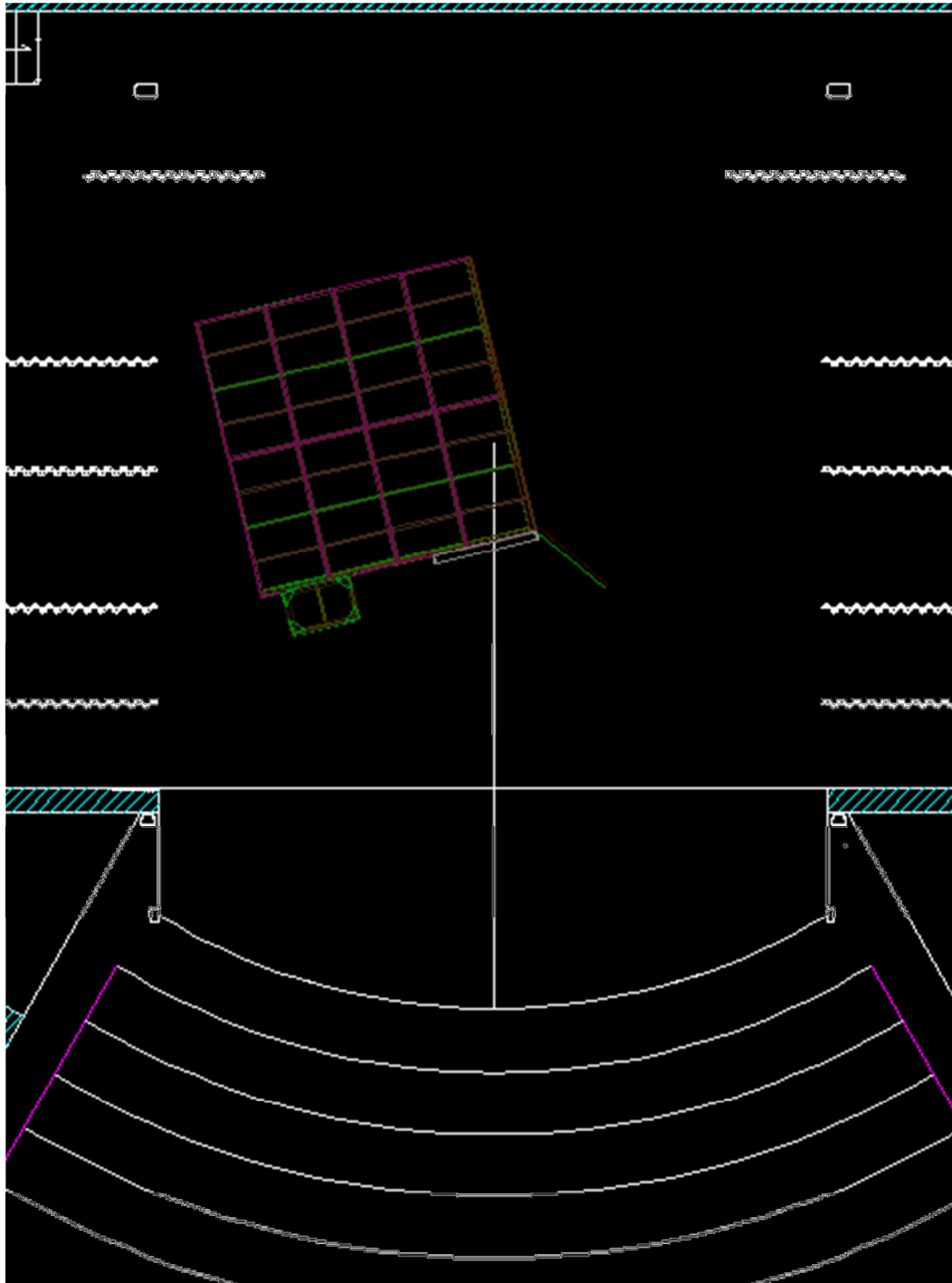

RECORD SHOP GROUND PLAN

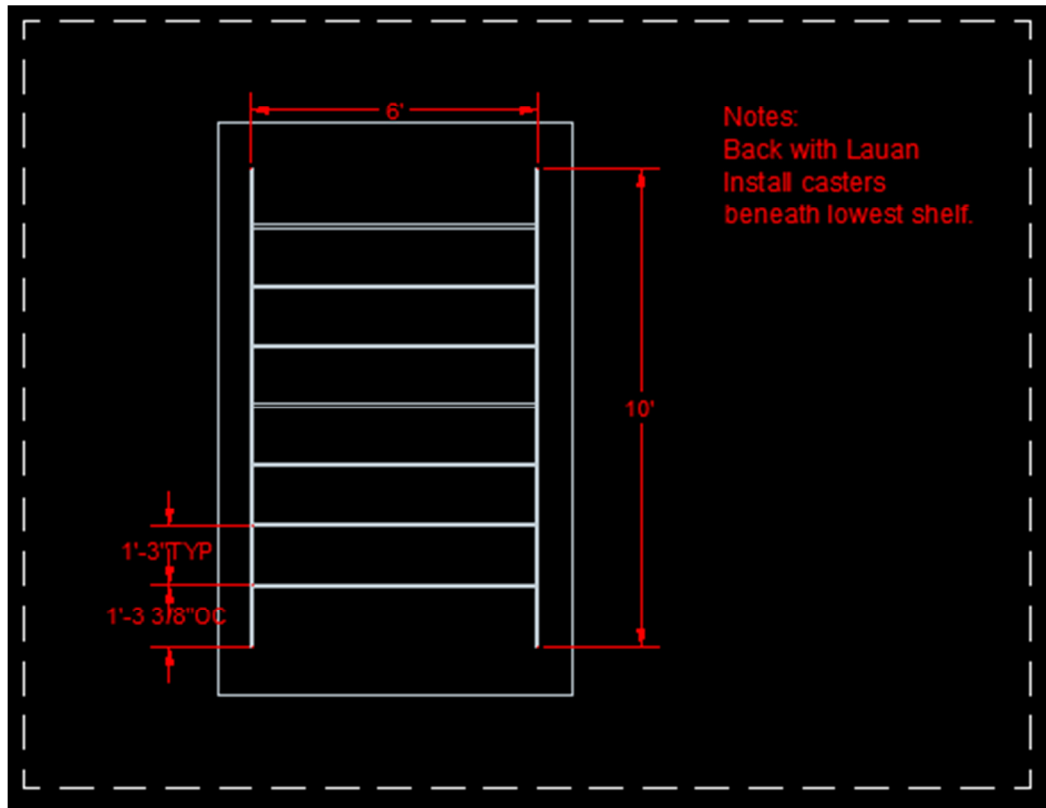

RECORD DISPLAY SHELF

ROUGH SHOP DRAFTING

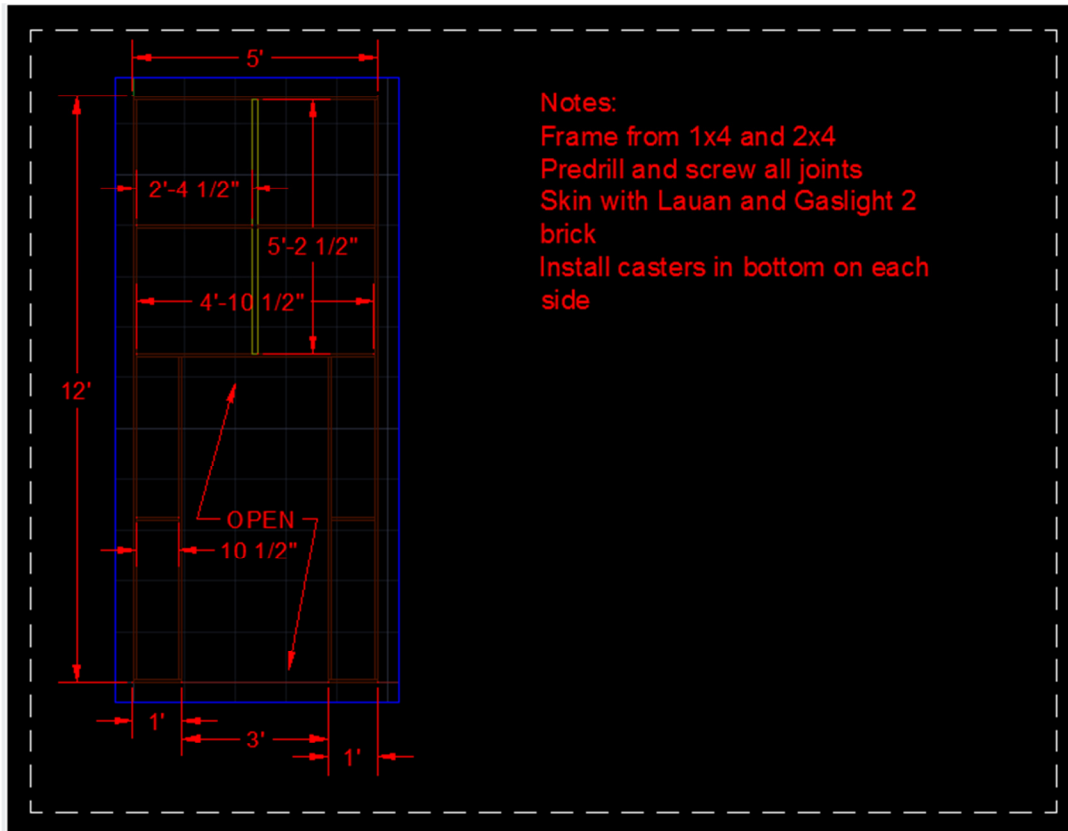

RECORD SHOP DOOR FLAT

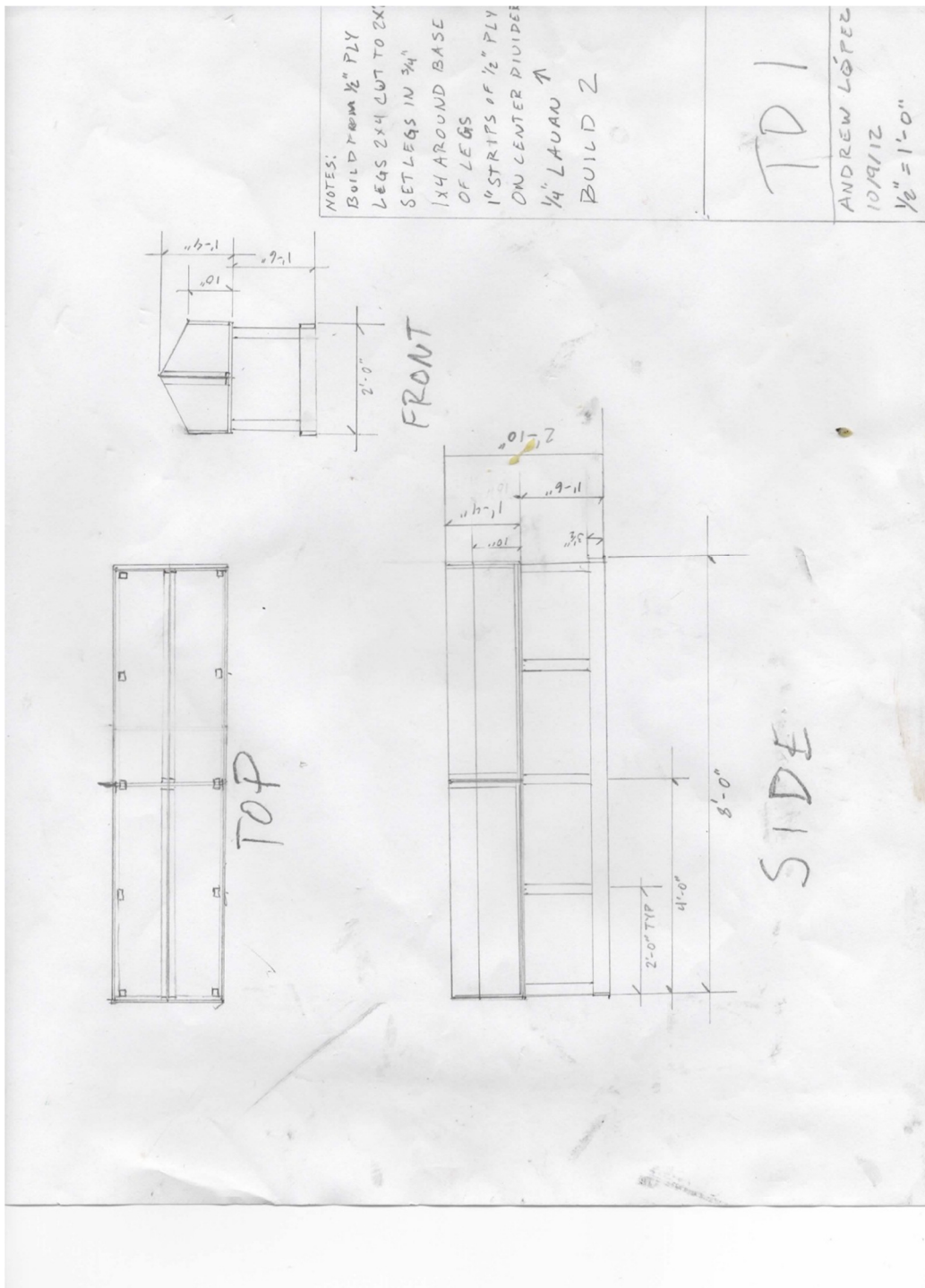

RECORD SHOP DISPLAY BINS

SHOP DRAWING

APPENDIX B

PROCESS PHOTOGRAPHS



DENTIST OFFICE WALL 2

REAR VIEW



APARTMENT UNIT

WALLS UP



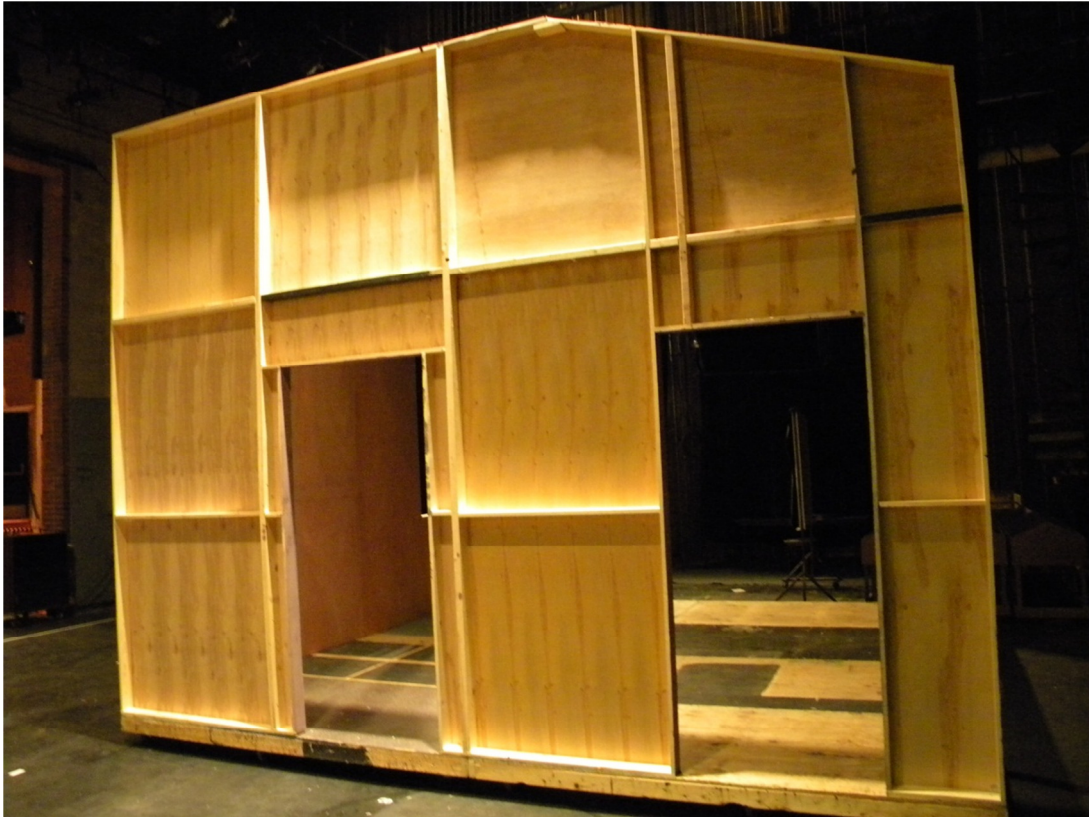

APARTMENT UNIT

REAR VIEW SR WALL

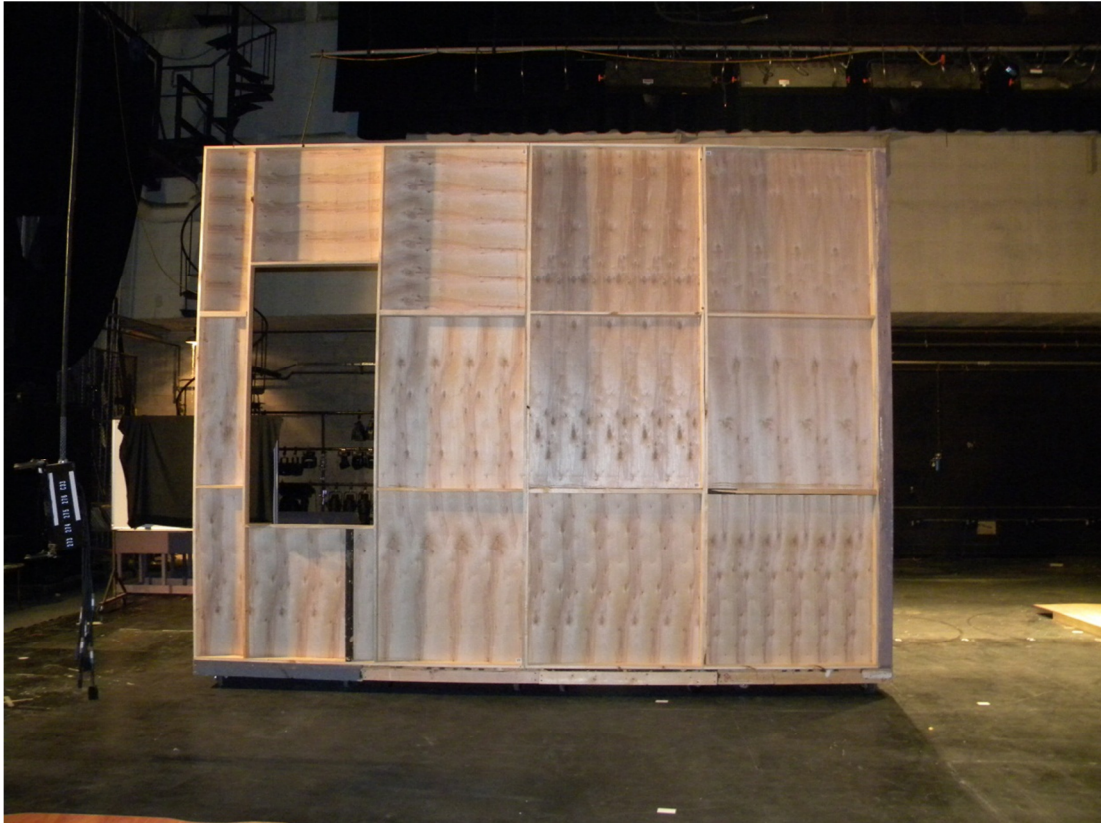

APARTMENT UNIT

REAR VIEW SL WALL



APARTMENT UNIT

SOUND BOARD AND MASONITE DECKING

IN PROGRESS



APARTMENT UNIT

FIRE ESCAPE PLATFORM

STAGE LEFT

RAILING NOT YET INSTALLED



APARTMENT UNIT

STAGE LEFT WINDOW INSTALLED



NIGHTCLUB WALL

JUST HUNG

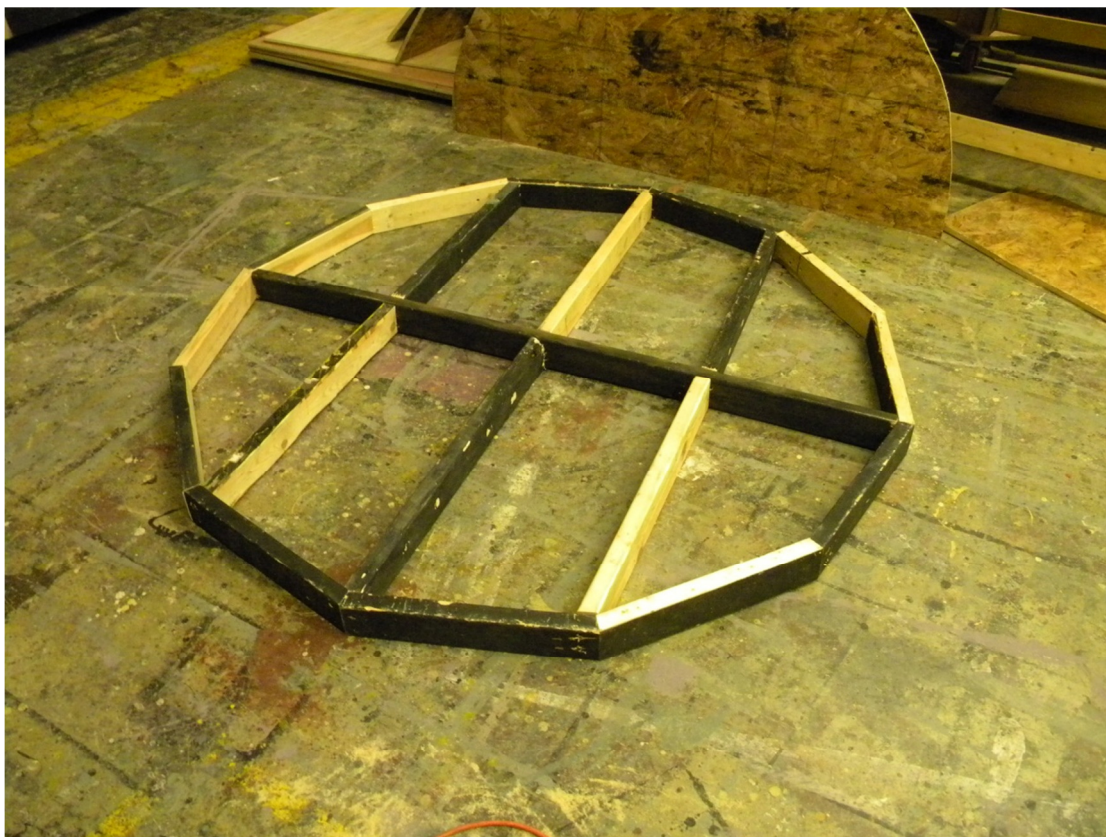

NIGHTCLUB BANQUETTE

BASE FRAMING



BANQUETTE

HALF DECKED





BANQUETTE

PARTIALLY COMPLETE



BANQUETTE

REAR VIEW



BANQUETTE

SEAT FRAMING DETAILS



BANQUETTE

NEARLY FINISHED



RECORD DISPLAY CASES

FINISHED BUT NOT PAINTED

APPENDIX C

PRODUCTION/MODEL PHOTOGRAPHS

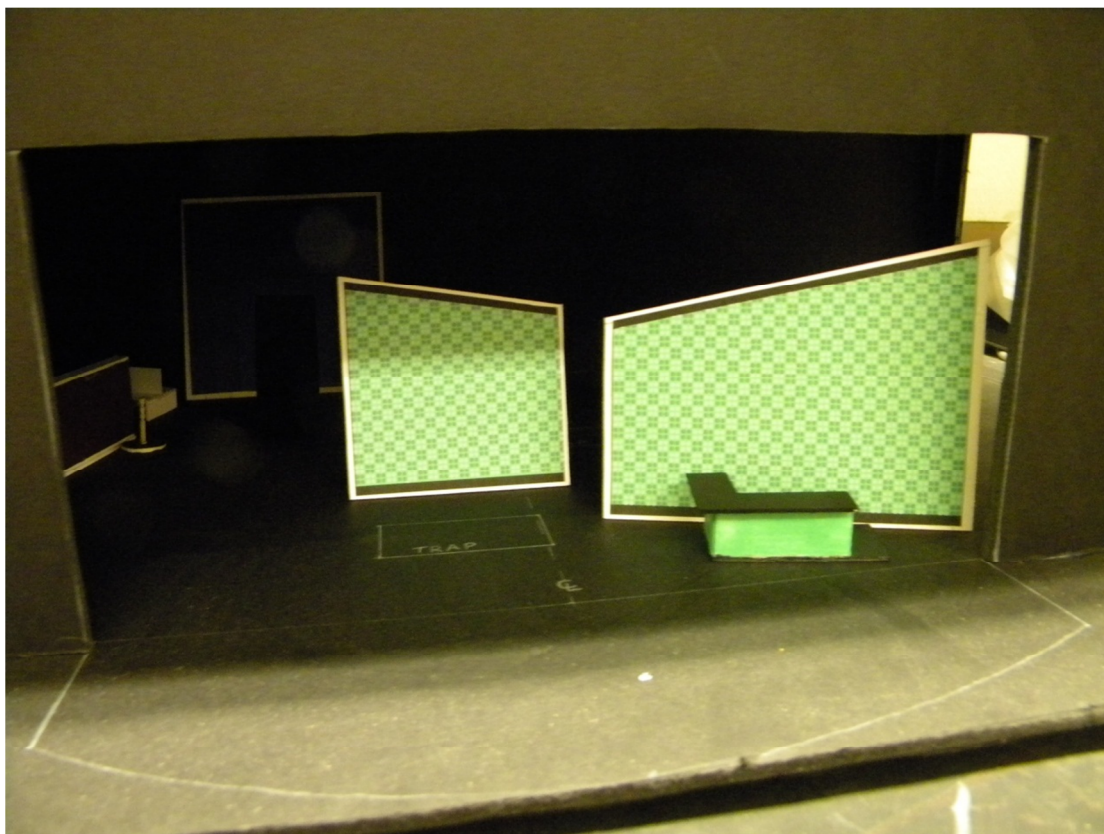

DENTIST OFFICE MODEL



DENTIST OFFICE SET

CUSTOM TOOTH SHAPED TABLE

BY SET DESIGNER NOAH FILES



DENTIST OFFICE

DESK DETAIL





DENTIST OFFICE

DESK DETAIL STAGE LEFT SIDE



DENTIST OFFICE

WALLPAPER AND STEREO DETAIL

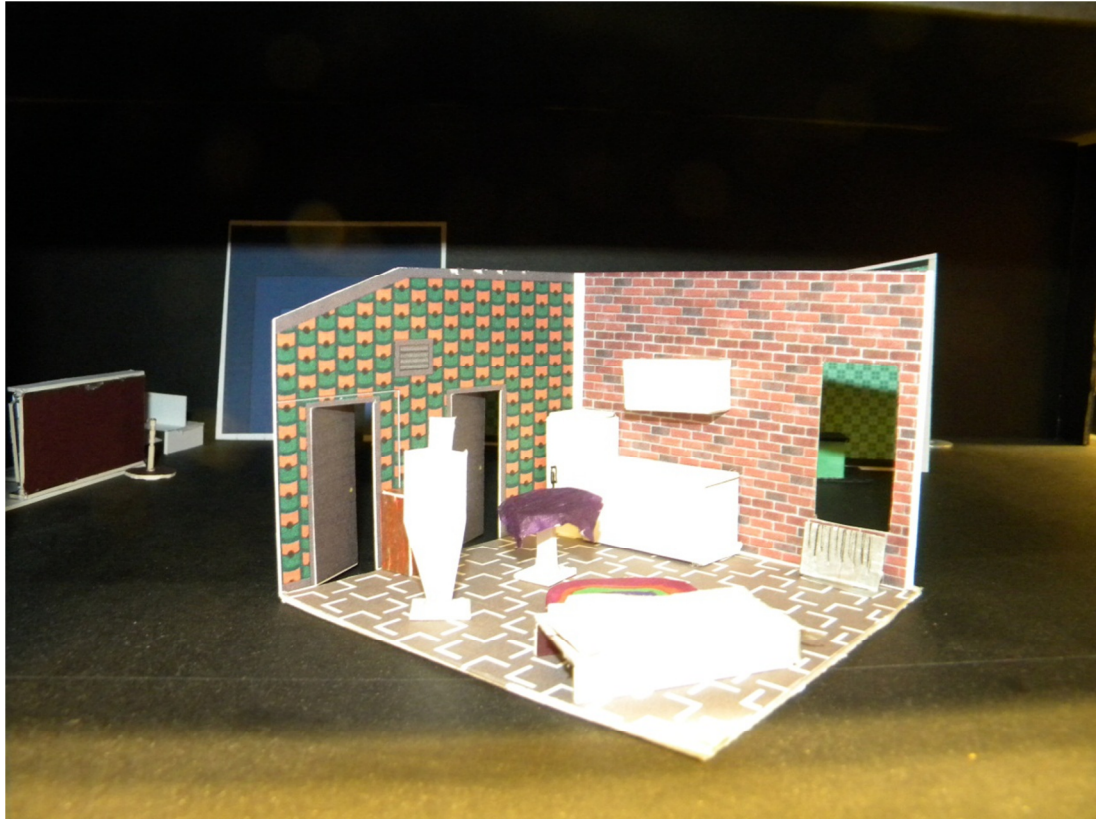

APARTMENT MODEL



APARTMENT SET LIGHT AND DARK



APARTMENT WALL  
STAGE LEFT DETAIL



APARTMENT SET  
STAGE RIGHT WALLPAPER DETAIL



NIGHTCLUB SET



NIGHTCLUB

WALL DETAIL





NIGHTCLUB

STAGE RIGHT BANQUETTE DETAIL



NIGHTCLUB

STAGE RIGHT BANQUETTE DETAIL



RECORD SHOP SET



RECORD SHOP

LISTENING BOOTH

DISPLAY RACKS



RECORD SHOP

POINT OF SALE



RECORD SHOP

DISPLAY SHELVING

## WORKS CITED

- Biemiller, Carl L. "Alias Abe Burrows." Holiday 9.3 (1951): 22-26. Print. 30 Sept. 2012.
- Boies, J.J. "Oasis on Broadway." National Review 18.30 (1966): 739-740. Print. 30 Sept. 2012
- Burrows, Abe. *Cactus Flower*. New York: Samuel French, Inc. 1966
- Burrows, Abe. *Honest Abe: Is There Really No Business Like Show Business?* Boston: Atlantic-Little, Brown, 1980.
- "Carry On, Nurse." Newsweek 66.23 (1965): 92-93. Print. 30 Sept. 2012
- "Cartesian Dentist." Time 68.25 (1965): 40. Print. 30 Sept. 2012
- E. J. Kahn, Jr. "Abe Burrows: What He Does to Earn \$2000 a Day." McCalls 92.5 (1965): 115-116,164-166. Print. 30 Sept. 2012
- Gehman, Richard B. "Abe Burrows, A Happy Pilgarlic." Theatre Arts 35.4 (1951): 30-33. Print. 30 Sept. 2012
- "Late Bloomer." Time 94.25 (1969): 78. Print. 30 Sept 2012
- Martin, P. "Song Buster." *Saturday Evening Post* 218.(1946): 34. Readers' Guide Retrospective: 1890-1982 (H.W. Wilson). Web. 30 Sept. 2012.
- "Nurse Bacall Gets Unstarched." Life 60.6 (1966): 35-36. Print. 30 Sept. 2012
- Oberbeck, S. K. "Loves of a Dentist." Newsweek 74.26 (1969): 54-55. Print. 30 Sept. 2012
- "Variety Somewhat Short on Spice." New Yorker 41.44 (1965): 152. Print. 30 Sept. 2012
- Willis, Edgar E. Writing Television and Radio Programs. New York: Holt, Rinehart and Winston, Inc., 1967.