



Munich Personal RePEc Archive

# **Integration of Energy Storage and Distributed Generation (DG) in Distribution Systems: Economic Analysis and Development Perspective**

Saeed Mohajeryami and Ronald Jennings and Ghadeer Alkhbbaz

Department of Systems Engineering and Engineering Management  
University of North Carolina at Charlotte Charlotte, NC, USA

1 May 2015

Online at <https://mpra.ub.uni-muenchen.de/70659/>  
MPRA Paper No. 70659, posted 13 April 2016 06:54 UTC

# **Integration of Energy Storage and Distributed Generation (DG) in Distribution Systems: Economic Analysis and Development Perspective**

**Saeed Mohajeryami, Ronald Jennings, Ghadeer Alkhbbaz**

Department of Systems Engineering and Engineering Management  
University of North Carolina at Charlotte  
Charlotte, NC, USA

Copyright © 2016 S. Mohajeryami et al. This article permits unrestricted use, distribution, and reproduction in any medium, provided the original work is properly cited.

## **Abstract**

This paper sheds light on distributed generation (DG) and energy storage and their impacts on electricity distribution networks. The purpose is to consider the various technologies of DG and energy storage and their financial and dynamic influence on the distribution network performance. In this paper, some different business cases in the U.S. related to energy storage and DG are investigated. One of these cases is related to Hawaiian Electric CO. One of the goals of Hawaiian Electric Co. for 2030 is to provide at least 65 percent of its electricity from renewable resources and working on providing sufficient energy storage. The company is considering energy storage project proposals on Oahu in order to provide their services by 2017. The paper will provide a look inside the company and how they are managing their existing projects and their future plans.

**Keywords:** Distributed Generation (DG), energy storage system, economic analysis

## **1. Introduction**

Energy storage in past was limited to large scale pumped-hydro systems and its rationale was storing the cheap electricity of night time and use it during the peak time as a peak-shaving tool (Celli et al., 2009). But the problem with pumped-hydro was that they were capital-intensive and they needed special circumstances along with so many environmental concerns. Therefore, energy storage concept did not go further than pumped-hydro for a long time. But thanks to the new emerging technologies in power electronics, the new small-scaled energy storage systems became efficient and affordable. With emerging distributed generation technologies, another application was found for energy storage systems. Energy storage systems can take a complementary role for intermittent renewable resources and to distributed generation in general. Integration of combination of energy storage systems and distributed generation into the grid can introduce lots of business opportunities to utilities, customers and vendors.

Implementing all new technologies formed by power electronics played an essential role in developing energy storage and DG over the years besides escalating their efficiency. However, Energy storage and DG are supposed to be more efficient and accurate in the upcoming years as more technologies and methodologies are being developed. It is hard to predict how sufficient these systems are going to be, but until now they came far along from the past.

## **2. Distributed Generation technologies**

Distributed Generation is electricity generations sources that are connected to distribution systems and not transmission network. Direct connection with distribution systems has this feature that it is going to be used locally (Davoudi, et al. 2015). It means that it is not going to provide a wide area. Based on this definition, even some large power stations, such as Combined Cycle Gas Turbines (CCGTs), as well as Combined Heat and Power (CHP) technologies of any scale can be considered as DGs. they can be installed by individuals, businesses, communities and schools.

DG has many kinds of technologies on a wide range of scales, they are going to be explained in detail in the following. Total installed DG capacity until December 2010 was about 7.011 GW, of which more than 50% was conventional steam stations and CCGT stations, which contributed about 4.647 GW. The rest consists of hydro-electric station (natural flow) of 0.133 GW, wind of 0.484 GW and other renewable sources of 1.747 GW (Hidayat and Li, 2013).

Some of the DG technologies are briefly introduced as follows.

## **2.1. Reciprocating engines**

This DG technology was developed more than a century ago, and is still widely utilized in a broad array of applications. The engines range in size from less than 5 to over 5,000 kW, and use either diesel, natural gas, or waste gas as their fuel source. Reciprocating engines are being used primarily for backup power, peaking power, and in cogeneration applications.

## **2.2. Micro-turbines**

Micro-turbines promise low emission levels, but the units are currently relatively expensive. Obtaining reasonable costs and demonstrating reliability will be major hurdles for manufacturers.

## **2.3. Industrial combustion turbines**

A mature technology, combustion turbines range from 1 MW to over 5 MW. They have low capital cost, low emission levels, but also usually low electric efficiency ratings. Development efforts are focused on increasing efficiency levels for this widely available technology. Industrial combustion turbines are being used primarily for peaking power and in cogeneration applications.

## **2.4. Fuel cells**

Although the first fuel cell was developed more than one hundred fifty years ago, this technology remains in the development stage. Fuel cell emission levels are quite low, but cost and demonstrated reliability remain major problems for the market penetration of this technology.

## **2.5. Photovoltaics**

Commonly known as solar panels, photovoltaic (PV) panels are widely available for both commercial and domestic use. Panels range from less than 5 kW and units can be combined to form a system of any size. They produce no emissions, and require minimal maintenance.

## **2.6. Wind turbine systems**

They provide a relatively inexpensive (compared to other renewables) way to produce electricity, but as they rely upon the variable and somewhat unpredictable wind, are unsuitable for continuous power needs. Development efforts look to pair wind turbines with battery storage systems that can provide power in those times when the turbine is not turning (Maine public utilities commission, 2001).

The technical characteristics of DGs are shown in table 1 (Guan et al., 2009).

**Table 1:** Technical characteristics of DGs (Guan et al., 2009).

technique Type	diesel reciprocating generator	natural gas reciprocating generator	Micro-turbine	natural gas fuel turbine	fuel cell	Solar	wind power
capacity	30kW -6+MW	30kW -6+MW	30 -400kW	0.5 -40+MW	100 -3000kW	1kW -1MW	600kW -2500kW
installation cost (\$/kW)	600 -1,000	700 -1,200	1200 -1,700	400 -900	4000 -5,000	6600	250 -312.5
power efficiency (LHV)	30-43%	30-42%	14-30%	21-40%	36-50%	6%-19%	2%-34%
total operation efficiency	80-85%	80-85%	80-85%	80-90%	80-85%	45%-60%	40%-78%
total operation cost (\$/kW)	0.005 -0.015	0.007 -0.020	0.008 -0.015	0.004 -0.010	0.0019 -0.0153	0.001 -0.004	0.0125 -0.025
site area	.22-31	.28-.37	.15-.35	.02-. 61	.9	Uncertain , depending on the size of the power	Uncertain , depending on the size of the power
pollution level ( gm/bhp-hr)	NOx:7-9 CO:0. 3-0. 7	NOx: 0. 7-13 CO:1-2	NOx:9-50ppm CO:9-50ppm	NOx:<9-50ppm CO:<15-5Oppn	NOx:<0.02 CO :< 0. 01	Nothing	Nothing
reliability level	higher	higher	no operation experiment	higher	high	not high	not high
main application fields	Back-up unit for industrial, commercial, public institutions	Generator-driven cogeneration plant	CHO	peak clipping	Residents' install electricity, CHP	Residential, commercial electricity and power supply in remote areas	power supply in remote areas and Plateau zone
schedulable	schedulable	schedulable	schedulable	schedulable	schedulable	not schedulable	not schedulable
installation position limitation	unlimited	limited	unlimited	limited	unlimited	limited	limited

### 3. Energy Storage technologies

There are different type of energy that electrical energy could be including electromagnetic, electrochemical, potential, or kinetic. However, there are some challenges that should be addressed. Two of main challenges are the capacity of an energy storage and also the way the energy should be converted to store.

Moreover, there are some other parameters limiting the application of different technologies such as how efficient the storage system is, what is its response time, the reliability, and availability (Moghaddam, et al. 2016). In this section, different types of energy storage systems would be described briefly. The aforementioned differences are tabulated in Table 2 for the comparison.

#### 3.1. Conventional Pumped Hydro Storage (PHS)

The most broadly employed technology in energy storage is the pumped

hydro storage. This technology involves pumping water to a higher reservoir to store energy. Afterwards, whenever it is necessary, the water would be pumped down in order to generate electricity by using hydro generators. However, there are some environmental concerns regarding the use of this technology. Furthermore, this technology has a serious limitation namely the limitation of water resource suitable for this technology.

### **3.2. Compressed Air Energy Storage (CAES)**

CAES is another technology which became a conventional method in storing energy. In this technology, the electricity is generated from the compressed air reservoir. Similar to PHS, first, the electric energy would be converted to potential energy during off peak time and then whenever it is necessary, it would be used to generate electricity. This conversion from potential energy to electricity mostly happens during the time periods of high demand. In this type, compressed air would be stored in underground reservoirs with high pressure. The main disadvantage of this technology is safety problem. Safety concern which is due to difficulties in storing high-pressure air underground would limit the application of this technology.

### **3.3. Battery Energy Storage System**

Since batteries store energy in electrochemical way, they have low time response. However, they have a very high efficiency. Battery energy storage systems attracted a lot of attention after Tesla announced building its battery manufacturing mega-factory.

### **3.4. Advanced Capacitors**

Although capacitors are well known and conventionally used in distribution systems, their application as a storage system is new. Hyper-capacitors and Ultra-capacitors are two of advanced types of capacitors utilized to store energy in a more efficient manner.

### **3.5. Superconducting Magnetic Energy Storage (SMES)**

SMES employs electromagnetic energy to store electrical energy. The mechanism used in this technology is in the following way. DC current would flow through a superconducting coil creating an electromagnetic field which energy can be stored in. This technology has the capacity to store up to 3 MW because of its high efficiency and low time response. They are utilized in power system in order to improve power quality (Schoenung et al., 1996). Table 2 shows the diversity of energy capacity and power level among different types of energy storage systems (Bartun and Infield, 2004).

**Table 2:** Features of Energy Storage systems

<b>Features</b>	<b>PHS</b>	<b>CAES</b>	<b>Battery</b>	<b>Advanced Capacitors</b>	<b>SMES</b>
<b>Power Level</b>	2 GW	100-300 MW	30 MW	100 KW	200 kW
<b>Energy Level</b>	Less than 25000 MWh	Less than 7200 MWh	Less than 200 MWh	0.3 kWh	0.6 kWh
<b>Response Time</b>	30-40 ms	15 min	30 ms	5 ms	5 ms
<b>Efficiency</b>	70%-75%	85%	70%-80%	90%	90%

#### **4. Impact of DG on electricity distribution networks**

The penetration of DG may impact the operation of a distribution network in both beneficial and detrimental ways. Some of the positive impacts of DG are: voltage support, power loss reduction, support of ancillary services and improved reliability, whereas negative ones are protection coordination, dynamic stability and islanding (Ghakar et al., 2013).

There are several potential applications that DGs can be used. DGs can reduce charges in some conditions. They are also more environmental friendly and they can be a good choice for people who are concerned. DGs also can be used for utilities for both enhancement of their system and also deferral of some unnecessary upgrade. The following list is some potential applications that might interest potential customers.

##### **4.1. Continuous Power**

There are some critical loads that need to operate continuously and any disruption can harm them significantly in terms of profit and also damage to their assembly line.

##### **4.2. Combined Heat and Power (CHP)**

In industries that DG operates at least 6000 hours per year, they use the DG waste heat for purposes like water heating, space heating, steam generation or other thermal needs. In some instances this thermal energy can also be used to operate special cooling equipment.

#### **4.3. Peaking Power**

In this application, DGs are used for peak-shaving purposes and it can reduce the overall electricity costs. The most common applications are in educational facilities, lodging, miscellaneous retail sites and some industrial facilities with peaky load profiles.

#### **4.4. Green Power**

Since DGs are less pollutant than the other traditional electricity generators, it can be used to reduce the harmful emissions.

#### **4.5. Premium Power**

DG is used to provide electricity service at a higher level of reliability and/or power quality than typically available from the grid. The growing premium power market presents utilities with an opportunity to provide a value-added service to their clients.

#### **4.6. Emergency Power System**

In this application, DGs function as a backup for the main provider and if the main fails, it will be replaced automatically. In this application DGs are backup for power critical devices whose failure can lead to property damage or safety threat.

#### **4.7. Standby Power System**

This independent system provides electricity to replace the normal source if it fails and thus allows the customer's entire facility to continue to operate satisfactorily. Such a system is critical for clients like airports, fire and police stations, military bases, prisons, water supply and sewage treatment plants, natural gas transmission and distribution systems and dairy farms.

#### **4.8. True Premium Power System**

Clients who demand uninterrupted power, free of all power quality problems such as frequency variations, voltage transients, dips, and surges, use this system. Power of this quality is not available directly from the grid – it requires both auxiliary power conditioning equipment and either emergency or standby power.

#### **4.9. Transmission and Distribution Deferral**

DG can be used to meet the increased demand; therefore, automatically it defers the need to invest on new infrastructure.



#### **4.10. Ancillary Service Power**

DG can also provide ancillary services. In electricity markets of some countries, these services can be sold. So, this application can have direct monetary benefit. Ancillary services include spinning reserves and non-spinning, or supplemental, reserves, Reactive supply and voltage control (Ghakhar et al., 2013).

DG changes the structure of the distribution system. It introduces both opportunities and threats in the same time. Opportunities should be taken advantage of and threats should be addressed to let this new structure to prevail. In the following, it will be shown the impact of DG on the voltage profile, system losses, and system reliability.

#### **4.11. Voltage Profile**

The distribution systems are usually regulated through tap changing at substation transformers and by the use of voltage regulators and capacitors on the feeders. DGs if located carefully and optimally can improve the voltage profile along with providing active power to loads.

#### **4.12. Losses**

DG causes a significant impact in electric losses due to its proximity to the load centers. DGs if located optimally in the distribution system, can minimize the loss significantly. The main difference is that the DG units cause impact on both the active and reactive power, while the capacitor banks only have impact in the reactive power flow. In feeders with high losses, a small amount of DG strategically allocated (10-20% of the feeder load) could cause a significant reduction of losses.

#### **4.13. Reliability**

It is important to plan and maintain reliable power systems because cost of interruptions and power outages can have severe economic impact on the utility and its customers. The analysis of customer outage data of utilities has shown that the largest individual contribution for unavailability of supply comes from distribution system failure. One of the main purposes of integrating DG to distribution system is to increase the reliability of power supply. DG can be used as a back-up system or as a main supply. DG can also be operated during peak load periods in order to avoid additional charges (Ghakhar et al., 2013).

### **5. Impact of Energy storage systems on electricity distribution networks**

Energy storage systems attracted a lot of attention recently because of the increasing presence of renewable energies and other distributed generation(DG)

technologies. If energy storage systems combine with DGs, they can change the structure of power system and help it to go toward smart grid.

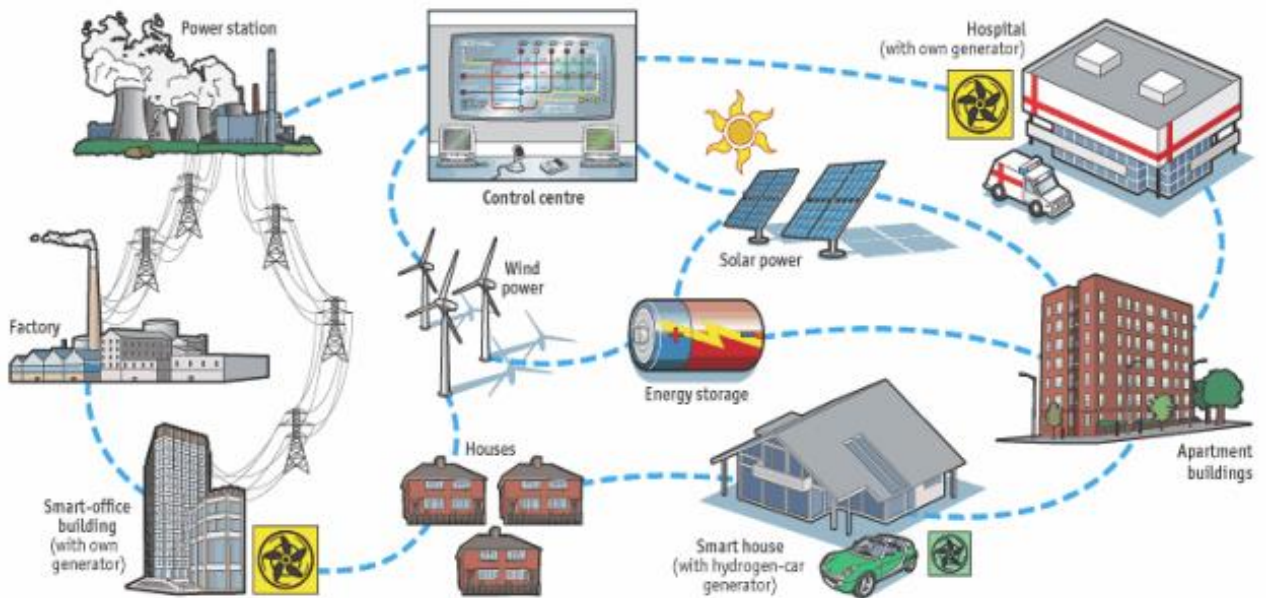

**Figure 1:** Smart grid system layout (Dolan technology center)

Installation of energy storage can be in different levels, e.g. grid level, substation level and small community level. Fortunately, the decreasing cost of these technologies let energy storage to be employed and implemented by commercial and industrial companies as well. What makes it possible is high price rate of peak-load hours and also due to unscheduled outage in the grid.

Providing reliable power during high consumption periods is one of the challenges that utilities face. These high consumption periods typically happen during evening and morning. Therefore, for a short period of time, utilities or power plant generation owners should employ their expensive generator units to meet the high peak time load demand. Investing on power plants to use for a short period of time is very costly for utilities; however, due to their obligation to serve, they should invest on these power plants anyway. Furthermore, high peak time consumption pose a threat to the system stability by overloading the transmission & distribution lines. If advanced energy storage system integrated with DGs be employed in the substation and community level, they can provide a viable solution for the aforementioned issues. In another words, they can relieve the congestion of the transmission lines. Additionally, It affects the cost significantly.

Several studies are done to see how energy storage systems in substation and

community level can manage and reduce total demand load. Additionally, energy storage systems could improve the operation of the micro-grids and reduce the power losses in the system (Kwhannet et al., 2010). The scheme and model introduced by Kwhannet et al., 2010, shows that energy storage system would reduce the total energy losses in the entire system by 6.67% in one-day operation. Figure 2 illustrates a small community energy storage (Geth et al., 2010).

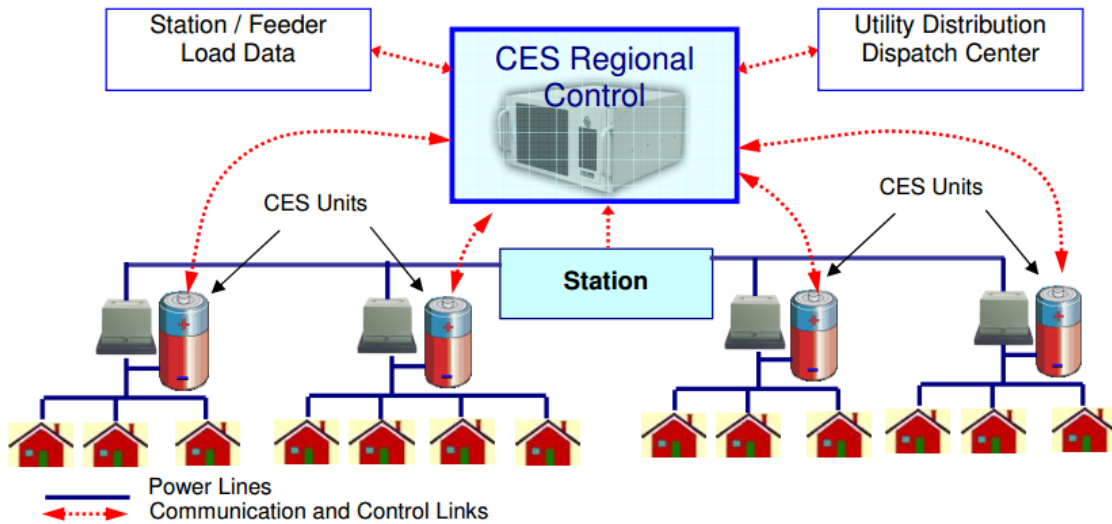

**Figure 2:** Communication and control layout of community energy storage (Geth et al., 2010).

In community level energy storage (CES) several batteries are employed. These batteries are connected to the transformers and could be controlled remotely from a central control. These batteries usually are constructed as pad-mounted next to a pad-mounted transformer or pole-top transformers. Also, the batteries are going to be installed underground. Figure 3 illustrates the configuration of a CES installation.

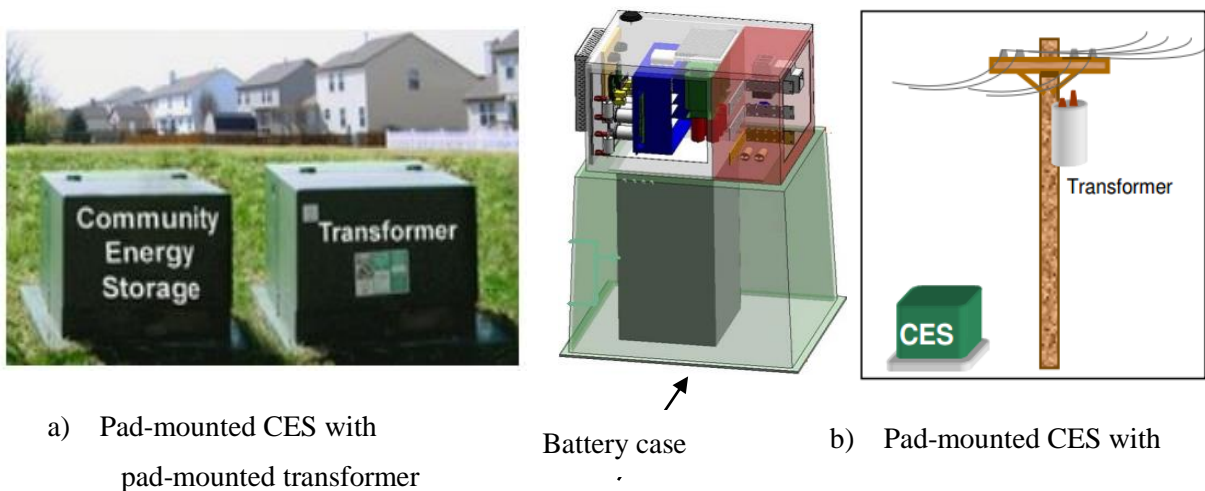

a) Pad-mounted CES with pad-mounted transformer

b) Pad-mounted CES with pole-top transformer

**Figure 3:** Installation configuration of CES in a residential community (Huq et al., 2012)

Energy storage system could be used for many different applications including power factor correction, local voltage control and also serving as backup power for local houses during outage. Advanced CES, if used along with smart grid could be used as a complementary way to store extra energy provided by renewable energy employed by customers. Moreover, in this application because of two way power flow, customers could install PV and wind turbine and sell their extra energy back to utilities.

(Huq et al., 2012) investigate Energy Management System (EMS) through modeling of a local energy storage which consists of PV and local power generation. This system is related to a community level micro-grid. The model proposed in (Huq et al., 2012) shows how this CES can facilitate the peak energy consumption reduction and provide peak load shaving. The results of this study for day-1 energy consumption is listed in Table. 3.

**Table 3:** Numerical results for peak load shaving (Huq et al., 2012)

<b>Day One</b>	
<b>Energy consumed from grid, kWh</b>	
Without energy storage	With energy storage
Total	
82.545	72.9776
Non peak hours	
20.028	39.2433
Peak hours	
62.517	33.37343

Large Industrial and commercial customers purchase electricity from wholesale market. In wholesale electricity market unlike retail market, the prices are volatile. They need to pay higher for each kWh during peak time periods compared to the retail tariffs. Therefore, energy storage can serve as a practical mean to store energy during off-peak time periods that have cheaper prices in order to avoid the purchase of expensive electricity during peak time periods. Another advantage of energy storage in this context is the ability to use it as a backup during unscheduled power outages or disturbances in the grid. It worth mentioning that for large industrial customers, power outages or low power quality are two sources causing major financial losses.

Integration of renewable energy and DER resources in the grid has a significant positive impact on the performance of grid. As discussed earlier, this combination could improve the power quality for industrial and commercial

customers. Uninterruptible power supply (UPS) systems have been employed over 30 years ago in the range of 1 kVA to as large as 1,000 kVA. Their deployment was one of the successful solutions of power system in the business area. UPS technology is developing steadily from its start and it can deliver up to 16 MW (Roberts et al., 2005).

## **6. Impact of Energy storage on DGs**

Introducing low-cost gas turbine and dramatic decrease of natural gas price had a huge impact on utility-scale pumped hydro systems. It made pumped hydro systems unable to compete with low-cost combined cycle gas turbines in the recent two or three decades. Nowadays, interests in energy storage options revived because of advances in technologies of energy storage options, which make them less expensive and more efficient. After power market deregulation and emerging power market and its consequent transparency in evaluation of economy of different decisions; the advantages of energy storage options in providing different needs of the system became evident (Denholm et al., 2010). Finding the other economic combinations like combination of DGs and energy storage systems made both of these two technologies more appealing compared to the traditional alternatives. In this part, the mutual impact of these two technologies on each other will be studied.

In past, the only variable in the power system was load and supply should have changed to meet the load, but with introducing renewable energies, load will become variable too. So, balancing supply and demand (load) and maintaining power system stability are serious issues that should be addressed (Yeleti and Fu, 2010). The integration of energy storage with renewable energy is one of the key solutions.

Both customers and utilities can benefit from the combination of renewable energy system and energy storage systems in the following ways (Nasiri, 2008).

- Storing PV energy during off-peak time and consuming it during peak time in order to remove peak consumption, i.e. peak shaving.
- Benefiting more from the cheap price of electricity offered by grid during weekends and holidays.
- Benefiting more from the cheap price of electricity offered by grid during night-time.
- Selling back the excess power during expensive peak time periods.
- Improvement of power quality and the reliability.
- Addressing the challenge imposed by the intermittency of sunlight and variability of wind speed by stabilizing the variable output power of renewable energy systems.
- Removing the costs of unnecessary spinning reserve thereby lowering the overall cost of the system.

- Aforementioned address of the challenge of intermittency of sunlight and variability of wind speed has a positive cascading impact on eliminating the power flickers and harmonics thereby improving the voltage stability.
- power system stability improvement.

Additionally, the energy storage supports critical load customers during fault situations. Moreover, it facilitates the black start of the entire power system. Overall, this integration makes the usage of available generation, transmission and distribution infrastructures more reliable, efficient and economic (Nasiri, 2008).

### 6.1. Energy storage for solar PV systems

Integration of energy storage and photovoltaic panels can benefit the customers and utilities in different ways. Customers can use this new integration in order to store electricity of PV during off-peak time periods which customers can benefit from cheap electricity of grid and consume this saved PV electricity during peak time which the electricity of grid is expensive. Its benefit for the utility is that it would relieve much of the pressure of peak time consumption.

According to some estimates, this integration could bring down the payback period of the PV investments to half of its current cost. Simple payback analysis for a case of 20kW PV installation (in Milwaukee) demonstrate that with using integrated storage a payback of 25 years can be changed to a payback of less than 15 years. Moreover, this system could play a different role as a UPS which increase the robustness of the system during the faults and outages.

Furthermore, its Benefits to utility side is similarly significant. It can address the intermittency issue of the solar devices. A block diagram of an integrated system of PV and energy storage is shown in Figure 4 (Nasiri, 2008).

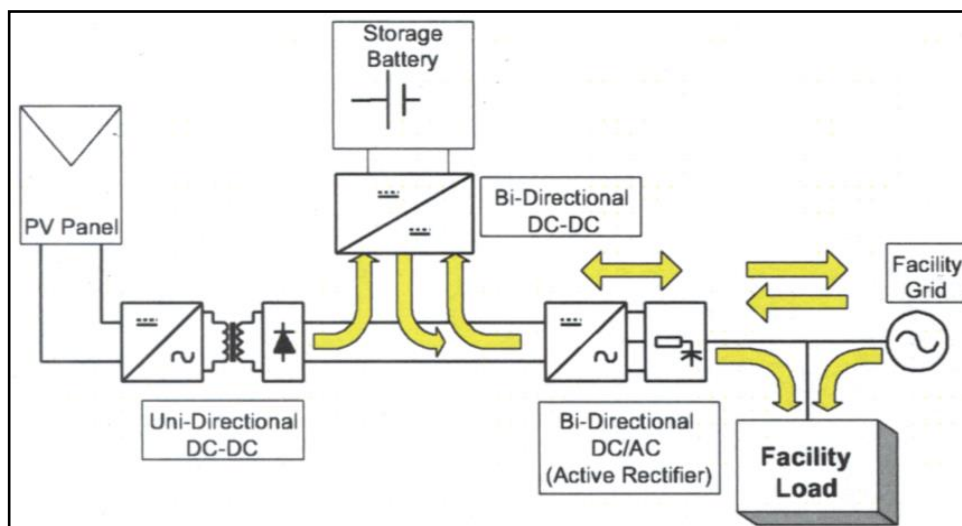

**Figure 4:** The block diagram of the integrated system of PV and energy (Nasiri, 2008).

## **6.2. Energy storage system for wind turbine systems**

Wind energy if integrated into the grid can introduce some negative impact on the power quality including lowering the quality of voltage and frequency and too much control requirements. Control circuits consisting of many power electronic devices increase the level of harmonic injection to the grid. The variability of wind speed causes power fluctuation. The energy storage system can help the wind energy to overcome the power fluctuations thereby improving the power quality and reliability. Since the battery storage systems have been used as long-term storage, SMES systems can be used in terms of short-term storage (Zahedi, 1994).

Strategies employed for smaller wind turbines are different from what they have been adopted for large-scale grid-tied wind power plants. For smaller wind plants, a significant portion of the wind energy can be stored in the storage system and be released when necessary. For large wind turbines, this solution is not feasible anymore unless large-scale compressed air or pumped hydro storage is available.

For grid-tied wind turbine systems, the benefits of the storage include (Nasiri, 2008):

- Addressing the challenge imposed by the variability of wind speed by stabilizing the variable output power of renewable energy systems.
- leveling the output power.
- Reducing the spinning reserve requirement.
- Peak shaving.
- Positive impact on the design of transmission line related parameters.

## **7. Case studies across the US**

In light of the recent green energy initiatives, initiated by the US federal government and followed by many states, it's expected to see an increasing penetration of renewable energies. For example, In August 2007, North Carolina enacted comprehensive energy legislation which included the first renewable energy portfolio standard which mandate all electric power suppliers in this state to mix their generation portfolio with a combination of renewable energy resources (such as solar, wind, hydropower, geothermal and biomass) and also reduce the energy consumption (North Carolina annual report, 2014). There are also economic incentives for residential users to use small-scale renewable energy facilities to meets their own energy needs.

The problem with renewable energy technologies is that they are inherently variable and their power output is difficult to predict. With increasing penetration, optimal integration will require some degree of matching of the generation profiles, the load profiles and the transport of electricity. Energy storage systems

can help to mitigate some of these problems and help to match generation and load profiles. Energy storage system can also help some of dynamic problems of the distribution network which otherwise needs an extra investment for improvement (Geth et al., 2010).

EPRI recently has developed an innovative methodology for rough evaluation of the energy storage opportunities. They analyzed 30 different cases in California. The results of analysis suggest that the majority of cases have benefit-to-cost ratio of greater than one. The analysis doesn't consider the indirect impact of energy storage on the functional improvement of the distribution system along with its environmental impacts (EPRI, 2013).

Energy Storage Association (ESA) provided multiple successful case studies to demonstrate the feasibility and performance superiority of energy storage systems compared to many other traditional alternatives.

Hawaiian Electric Co. is responsible for supplying electricity for Hawaii Island and due to their frustration from importing fossil fuel and also their successful renewable projects, it sets a goal of providing at least 65 percent of its electricity from renewable sources by 2030. Energy storage is also another aspect of this ambitious goal. It's a quotation from the Hawaiian electric companies report that "Energy storage systems, including batteries, will increase the ability to add renewables by addressing potential disruptions on electric grids caused by variable solar and wind power. Hawaiian Electric is evaluating proposals for energy storage projects on Oahu to be in service by early 2017. Energy storage projects are also in the works for Maui, Molokai, Lanai and Hawaii Island."

There are also several companies specializing in combined DG and energy storage and they are working with authorities to change the regulation to increase the penetration of DG and energy storage systems in the distribution system for the residential and commercial customers, these companies include big names like GE, LG chem, Solarcity, Tesla, Coda energy, Japan NEC corporation, etc. (Hering, 2014)

The State of Hawaii, as a vanguard in using renewable energy to meet its energy demands offers insight into how storage can be an answer to many questions raised by practical shortcoming of renewable energies. In this state, where renewable penetration percentages can already exceed 20-30% thresholds, wind and solar projects are utilizing storage technologies to allow their systems to interconnect. Advanced storage technologies have been utilized to meet these requirements. Solar applications on the island of Lanai and wind applications on Maui and Oahu were coupled with advanced storage (Fioravanti, 2011).

Vartanian, 2011, published a report about how multi-MW scale battery systems has been extended and used to integrate the renewable energy to two governmental funded smart grid demonstration projects. More information has been provided about the integration of the above-mentioned batteries with wind energy in (Vartanian et al., 2012) from the same company.

Using 1MW sodium-sulphur batteries (with total capacity of 7.2 MWh), in



2006, to meet peak demand's problem is another practical example (Yeleti and Fu, 2010).

## 8. Conclusions

Energy storage options in integration with renewable energies helped the utilities to increase the renewable energy penetration in their systems without stability concerns. More renewable energies can translate itself into less fossil fuel power plant production. Stand-alone energy storage systems can also release the spinning reserve in the system, which is tantamount to burning less fossil fuel. Advanced Energy storage options not only are environmentally and systemically advantageous, but also can have financial benefits in the long run. Selling high-price ancillary services, functioning as an UPS along with increasing the efficiency of renewable systems can give these options economical merits.

## References

- [1] Annual Report Regarding Renewable Energy and Energy Efficiency Portfolio Standard in North Carolina, Oct. 1st, 2014, available [online]: <http://www.ncuc.commerce.state.nc.us/reports/repsreport2014.pdf>
- [2] J. P. Barton, D.G. Infield, Energy Storage and Its Use with Intermittent Renewable Energy, *IEEE Transactions on Energy Conversion*, vol. 19, No. 2, June 2004
- [3] G. Celli, S. Mocci, F. Pilo, M. Loddo, Optimal integration of energy storage in distribution networks, *IEEE power technology (PowerTech)*, Bucharest, 2009
- [4] P. Denholm, E. Ela, B. Kirby, M. Milligan, "The Role of Energy Storage with Renewable Electricity Generation", Technical Report, NREL/TP-6A2-47187, January, 2010
- [5] Dolan Technology Center. Available [Online]: <http://www.dolantechcenter.com>
- [6] M. Davoudi, V. Cecchi and J. R. Agüero, "Increasing penetration of Distributed Generation with meshed operation of distribution systems," *North American Power Symposium (NAPS)*, Pullman, WA, 2014.
- [7] Energy Storage Association, Case studies, Available [online]: <http://energystorage.org/energy-storage/case-studies>

- [8] EPRI report of “Cost-Effectiveness of Energy Storage in California”, 2013, Available [online]: [http://www.cpuc.ca.gov/NR/rdonlyres/1110403D-85B2-4FDB-B927-5F2EE9507FCA/0/Storage\\_CostEffectivenessReport\\_EPRI.pdf](http://www.cpuc.ca.gov/NR/rdonlyres/1110403D-85B2-4FDB-B927-5F2EE9507FCA/0/Storage_CostEffectivenessReport_EPRI.pdf)
- [9] R. Fioravanti, How is Advanced Storage Being Used to Integrate Large Percentages of Renewable into the Grid?, Power Systems Conference and Exposition (PSCE), IEEE/PES, 20-23 March 2011
- [10] P. Gakhar, T. Manglani, D. K. Doda, Advancement and Role of DG Technology in Distribution System, *International Journal of Recent Research and Review*, Vol.6, June 2013
- [11] F. Geth, J. Tant, E. Haesen, J. Driesen, R. Belmans, Integration of energy storage in distribution grids, IEEE Power and Energy Society General Meeting, 25-29 July, 2010
- [12] F.H. Guan, D.M. Zhao, X. Zhang, B.T. Shan, Z. Liu, Research on distributed generation technologies and its impacts on power system, International conference on Sustainable Power Generation and Supply, 2009.
- [13] K.M.M. Huq, M.E. Baran, S. Lukic, O.E. Nare, An Energy Management System for a community energy storage system, Energy Conversion Congress and Exposition (ECCE), 2012 IEEE, pp.2759,2763, 15-20 Sept. 2012.
- [14] G. Hering, 11 innovative companies giving energy storage a jolt, Greenbiz Magazine, available [online]: <http://www.greenbiz.com/blog/2014/04/21/how-10-innovative-companies-are-giving-energy-storage-jolt>
- [15] M.N. Hidayat, F. Li, Impact of Distributed Generation technologies on generation curtailment, IEEE Power and Energy Society General Meeting (PES), July, 2013
- [16] U. Kwhannet, N. Sinsuphun, Ul Leeton, T. Kulworawanichpong, Impact of energy storage in micro-grid systems with DGs, International Conference Power system Technology (POWERCON), pp.1-6, 24-28 Oct. 2010
- [17] Maine Public Utilities Commission, “Assessment of Distributed Generation Technology Applications”, Feb. 2001
- [18] Moghaddam, B. Chowdhury, and S. Mohajeryami, “Optimal Operation and Sizing of Battery Energy Storage with High Wind Energy Penetration”, *IEEE Transaction on Smart Grid*, 2016

- [19] I. N. Moghaddam, B. Chowdhury, "Optimal Sizing of Hybrid Energy Storage Systems to Mitigate Wind Power Fluctuations" in *IEEE Power & Energy Society (PES) General Meeting*, July 2016
- [20] R. Morsali, N. Ghadimi, M. Karimi, S. Mohajeryami. "Solving a novel multiobjective placement problem of recloser and distributed generation sources in simultaneous mode by improved harmony search algorithm." *Complexity*, 2014.
- [21] A. Nasiri, Integrating Energy Storage with Renewable Energy Systems, IEEE 34th Annual Conference of Industrial Electronics, 10-13 Nov. 2008
- [22] B. Roberts, J. McDowall, "Commercial successes in power storage," *IEEE Power and Energy Magazine*, pp.24-30, March-April 2005
- [23] S.M. Schoenung, J.M. Eyer, J.J. Iannucci, S.A Horgan, "Energy storage for a competitive power market" *Annual Reviews of Energy and Environment*, 1996, pp. 341-370.
- [24] C. Vartanian, "A123 systems' advanced battery energy storage for renewable integration", Power Systems Conference and Exposition (PSCE), IEEE/PES, 20-23 March 2011
- [25] C. Vartanian, N. Bentley, R. Foster, "Application of Advanced Battery Energy Storage Systems for Wind Integration", IEEE Power and Energy Society General Meeting, 22-26 July 2012
- [26] S.Yeleti, Yong Fu, "Impacts of energy storage on the future power system", North American Power Symposium (NAPS), 26-28 Sept. 2010
- [27] A. Zahedi, "Energy, People, Environment". Development of an integrated renewable energy and energy storage system, an uninterruptible power supply for people and for better environment, IEEE International Conference on Systems, Man, and Cybernetics, Humans, Information and Technology, Oct 1994