

# MPRA

Munich Personal RePEc Archive

## **Research, Development, Production and Performance of heavy duty CNG fleets in Iran**

Nader Ale Ebrahim and Maziar Rostamnezhad and Ali  
Momeni

Tousee Khodrocar Company

1 September 2005

Online at <https://mpa.ub.uni-muenchen.de/28436/>

MPRA Paper No. 28436, posted 27 January 2011 18:50 UTC

IN THE NAME OF GOD

**Research, Development, Production and Performance of heavy duty CNG  
fleets in Iran**

ANGVA 2005  
Kualu Lumpur, Malaysia

**Nader Ale Ebrahim<sup>1</sup>, Maziar Rostamnezhad<sup>2</sup>, Ali Momeni<sup>3</sup>**

**Tousee Khodrocar Company**

9.5<sup>th</sup> karaj road – Nakhzarrin – TOUSEE KHODRO CAR (TKCCO) – Tehran – Iran.

**Abstract:**

Automobile industry is an exhaustive industry bringing development for any country. The industrial capabilities needed for development rest in this branch of industry. The Iranian automobile making companies move in line with this aim. But in recent decades, in addition to development of automobile industry, the pollution too has occupied the minds of the authorities of these companies. Some measures, investments, researches, and exhaustive studies related to the pollution problem have been made to produce an automobile of higher technology and lower pollution. The automobiles are the main source of pollution in high-populated cities of the world. Based on the studies made in this respect, the share of vehicles in total pollutants is about 70%. For decreasing the value of polluting gases coming out from the exhaust pipes of the automobiles, different solutions including using the fuels releasing less pollutant have been proposed. The experts have made huge studies on this subject and the result had been the development of substitute fuel technology.

Having these aims in consideration, Iran Khodro Diesel Company (IKD) has designed and implemented different projects to become able to produce suitable for the day technology and needs and being less pollutant. Using the substitute fuels is parallel to protection of the environment, national economic aims, and optimum use of the country's existing reserves and resources. Iran Khodro Diesel Company (IKD), as the biggest producer of diesel vehicles in the Middle East has taken great strides to collaborate in this national affairs and is determined to play its role in best possible way. In Tousee Khodro Car (R&D of IKD) many activities for reducing air and sound pollution, acceptable by EURO II Standards, have been done.

With these experiences, IKD have fitted out heavy duty fleet of Tehran and this paper is pointing out some of these activities such as CNG urban bus products, CNG minibuses products, CNG truck products and CNG intercity bus products in Iran.

The automaker companies are making their move towards these goals. But in the recent decades, besides the development of automobile industry, the problem of Emissions, along with other problems, has become a concern among the auto making companies. Therefore the research, investment and vast studies have been made in order to manufacture a vehicle with high technology and low pollution. Along with this, Iran Khodro Diesel also has developed different approaches and projects and has lunched them accordingly so that the end product has met the current need or technology with low pollutions. The conversion of vehicle to natural gas is one of them. The idea is to protect the environment and also use the countries natural resources efficiently. Iran Khodro Diesel Company as the largest manufacturer of Diesel engines in the Middle-East has taken some positive steps towards this national concern, and is determined to play a fine role in this national project. From an automaker point of view, there are series of considerations which ought to be made in which, these concerns should be on basis of economy, technical and environment. For Bus conversions, the procedure for changing design and manufacturing purposes, test and quality control plays a major role in which we intend to describe their activities and capabilities of different Departments briefly.

Natural gas is one of the most widely used alternative fuels to reduce global vehicular emissions. In an effort to improve their environmental position, government officials worldwide are setting yearly targets and implementing policies to increase the number of vehicles operating on compressed natural gas (CNG).Government is also employing various incentive programs or rebates to encourage conversion of vehicles to CNG or to offset the cost of purchasing OEM manufactured CNG vehicles. In many countries it is less expensive for a vehicle or fleet owner to purchase natural gas than imported gasoline or diesel, so the increase in the use of natural gas vehicles is being driven by economics and fleet operating efficiencies. Asia is also a dynamic market for CNG. In Iran, for example, the government has recognized the importance of using alternative fuels due to growing concern over the health of its citizens and increasing vehicular urban pollution levels.

Key Terms: natural gas, substitutes fuels.

---

1- M.S in Mechanical engineering (deputy of Iran Khodro Diesel)

2- B.S in Mechanical engineering (Vehicle design Expert)

3-M.S in Analytical Chemistry (CNG system Expert)

## **Introduction**

In recent years, along with the trend toward clean air and less dependency to imported oil products, there has been increasing willing to use substitute fuels in transport industry.

Automobile industry is an exhaustive industry bringing development for any country. The industrial capabilities needed for development rest in this branch of industry. The Iranian automobile making companies move in line with this aim. But in recent decades, in addition to development of automobile industry, the pollution too has occupied the minds of the authorities of these companies. Some measures, investments, researches, and exhaustive studies related to the pollution problem have been made to produce an automobile of higher technology and lower pollution.

Having these aims in consideration, Iran Khodro Diesel Company has designed and implemented different projects to become able to produce suitable for the day technology and needs and being less pollutant. The project for converting the gasoline-fueled vehicles to natural gas-fueled vehicles and using the products of natural gases such as di methyl ether are among these projects. Using the substitute fuels is parallel to protection of the environment, national economic aims, and optimum use of the country's existing reserves and resources. Iran Khodro Diesel Company, as the biggest producer of diesel vehicles in the Middle East has taken great strides to collaborate in this national affairs and is determined to play its role in best possible way.

The automobiles are the main source of pollution in high-populated cities of the world. Based on the studies made in this respect, the share of vehicles in total pollutants is about 70%. This share is mostly result of using fossil fuels. The outgoing gases of the exhaust pipe of the gasoline-fueled vehicles is a mixture of polluting gases of monoxide carbon ( CO), unburned hydrocarbons ( HC ), aldehydes and mixture of nitrogen oxides that scatters in the air along with lead combines ( existing in gasoline). Concerning gasoline-fueled vehicles, the exhaust gases consist of hundreds of chemicals scatted in the atmosphere in form of steam or absorbed in carbon particles that may be breathed. In addition to the suspended particles and sulphur compounds such as SO<sub>2</sub> the exhaust gases include gases such as HC and CO.

For decreasing the value of polluting gases coming out from the exhaust pipes of the automobiles, different solutions including using the fuels releasing less pollutants.

The experts have made huge studies on this subject and the result had been the development of substitute fuel technology.

Among these substitute fuels, different types of alcohols especially methanol and ethanol, DME, LPG liquid gas (which is normally a mixture of propane and butane with changing proportion depending on the situation and seasons) and compressed natural gas of CNG (mostly methane) are mentionable.

## **INTRODUCING IRAN**

Iran with an area of 1648195 square kilometers is neighbor with Armenia, Azerbaijan, and Turkmenistan (all former Soviet republics) and Caspian Sea on north, with Afghanistan and Pakistan on east, with Turkey and Iraq on west, and Persian Gulf and Oman Sea on south. The area of Iran is one fifth of the area of America and about three times of France.

Iran, as the heart of the Middle East, acts as a bridge and joins Caspian Sea (the biggest lake of the world) in the north to Persian Gulf and Oman Sea in the south and is a pass for political and cultural contacts of the east and the west. Abadan city is a rich oil field so Abadan changed in fact into a colony of the international petroleum companies. In 1950, Iranian government nationalized oil industry. 20 March of each year is celebrated in Iran as anniversary of nationalization of oil and is a public holiday.

Still oil excavation is carrying on in southwestern part of Iran and in Persian Gulf and the extracted oil is transferred to Tehran, Tabriz, Arak, and Esfahan oil refineries to be refined.

At the time being Iran is third largest oil exporting country of the world. In spite of low quality of production and continued sanction of USA, still oil is the main source of income and makes 40 percent of the government's revenues. As far as gas is concerned Iran is a country which holds about 17% of total reservoirs of natural gas in the world and is biggest country of the region having production capacity.

The geographical of the capital city of Iran, Tehran, is such that has deteriorated the air pollution. Being enclosed by high northern mountains has caused high volume of pollutants in time when there is no wind to drive the pollutants out of the city. A host of factors such as high altitude from the sea level (3300 - 5000 foot), incomplete combustion of fuels, natural structure of the city, and other human factors has made Tehran one of the most pollutant cities of the world [1].

### **Transportation fuels Substitution**

As you know, in the recent decades, besides the development of automobile industry, the problem of air pollutions, along with other problems, has become a concern among the automobile manufacturing. Therefore the research, investment and vast studies have been made in order to manufacture a vehicle with high technology and low pollution. Along with this, Iran Khodro Diesel Co. also has developed different approaches and projects and has launched them accordingly so that the end product has met the current state or technology with low pollutions. The conversion of vehicle to natural gas is one of them.

From an automaker point of view, there are series of considerations which ought to be made in which, these concerns should be on basis of economy, technical and environment. For products conversions (e.g. bus, truck & minibus) the procedure for changing design and manufacturing purposes, test and quality control plays a major role in which we intend to describe their activities and capabilities of different departments briefly.

One of the causes of air pollution in Tehran is overusing energy. After Islamic Revolution the consumption of energy has trebled. Total consumption of energy in Iran has increased from 1.6 quadrillion in 1980 to 4.5 quadrillion in 1998. This is a growth of more than 280% in energy consumption [1]. Petrol consumption is responsible for most part of energy consumption. With 435 gallons (1148 liters) per automobile per year, Iran is in second place of petrol consumption (after USA). Generally speaking, 55% of total energy consumption in Iran is oil products, 43% natural gas, and a very small percentage is coal.

Transportation industry, as one of the important subsets of communication is considered important and infrastructural sections of the economy of all societies. 25% of annual fuel consumption of the country, that is, 25 billion liters, is consumed in transport sector. The main part of transport industry is road transport. In better words, 95% of the consumed fuels are used on the roads and 1% is used by railway. Throughout the world including Iran, the growth rate of energy consumption has been higher in transport sector than other sectors. More worrying issue is that the growth rate of energy in transport sector has been 1.75 times of growth in national gross product. Transport sector is the principal consumer of fossil fuels.

To burn the fossil fuels results in the pollution of the air of big cities and will create many environmental risks. It is clear that using natural gas can solve the problem although to some degree. Of course, in the short-time there will be heavy cost but certainly there will be bright future in front of the country and the primary investment will be paid back in first years of

implementation. Today, the biggest environmental problem in Iran is air pollution especially in Tehran. In Tehran producing about 1.5 tons pollutants and the carbon dioxide that is released from the exhausts of the cars is responsible for the high percentage of the pollution. More than 500 thousand out of more than two millions motor vehicles existing in Tehran are more than 15 years old and lack catalytic converter for refining the pollutants releasing from the exhausts. Unfortunately, at present the big cities of the world are exposed to very serious dangers resulted from the pollutants and the automobiles are the main source of pollution in most-populated cities of the world. In this respect, Environment Protection Organization has acted more seriously. For preventing air pollution, the Organization has depended the plating of new automobiles to compliance with the standards including ECE1504 standard which later was changed to EURO1 standard. At present, Environment Protection Organization intends to enforce EURO2 standard which is the standard of European Union.

According to a study made in past five years, based on the average growth rate of automobiles in transport fleet of Iran by year 2020 the number of automobiles will reach from present 5.5 million to 15 million automobiles. In proportion to the increase in the number of vehicles, fuel consumption too will increase. The following figure shows the above fact [2]. At present, Iran is among the leading gas producing countries and there is a huge plan in South Pars area to produce natural gas. Iran holds vast gas pipeline that makes construction of natural gas stations possible in most parts of the country. Total roads of the country are more than 12000 kilometers and the natural gas pipeline run along 9700 kilometers of these roads. The studies show that investment in this sector is perfectly economical [2] of the advantages of CNG is its very low price in comparison to the common fuel. For instance in 12 European countries that use natural gas its price is 20-70 percent of the gasoline. The difference in prices is result of tax rate imposed on natural gas in different countries. In average, using natural gas decreases the annual cost of the vehicle fuels by 50%. In general, availability of huge gas resources, less exploitation and refinery costs of natural gas in comparison to liquid fuels and more importantly the existence of vast distribution network of natural gas in the vast country of Iran indicate the economic advantage of using natural gas in a nationwide level. Among other national advantages of this plan, importing less fuel, generating job opportunities, and less pollution in the big cities of the country may be pointed out.

### **Implemented projects:**

The company which with name of the well-known name of Iran Khodro Diesel is the source of national pride and honor is one of the biggest manufacturers of automobile in the Middle East. The company, with its development plans and having the biggest bus production line in the Middle East (with annual capacity of 5 500 buses and 15 000 trucks, minibuses, and vans) is honored to be the pioneer of automobile industry in the country and in producing the products with due regard of international and environmental standards. It is the reflex of the national pride of Iranian society in industry world. Erecting and using the biggest gas-fueled bus production line in the Middle East is one of the measures taken toward environmental aims. Converting the intercity and urban buses into gas-fueled buses is a national plan that is both economically and environmentally highly important and Iran Khodro Diesel Company has taken great strides toward this aim. The feasibility study, codification of the know-how, and making required studies for producing gas-fueled buses in the company started in 1998. A team composed of the experts of different disciplines started to study the gas-fueled buses in Iran and abroad and prepared the technology based on the latest achievements of the world.

The completed projects which have been implemented towards these goals are as follow:

- **Urban Bus with MAN Engine**
- **Gas-Fueled Minibus Project:**
- **Gas-Fueled Trucks Project:**
- **Gas-Fueled Intercity (couch) Bus Project:**
- **Gas-Fueled urban Bus Project with 0457 Engine**
- **Fixed and Mobile Charging Stations**







Clearly, for reinforcing the body with purpose of keeping the tanks and preventing concentration of tension in these points (because of increased weight), some modifications has been made on the body, chassis or different parts. In this system, different type tanks have been used side by side. Faber Company and MCS Company have made these tanks of steel or aluminum and reinforced them with composite fibers in radial direction .

After preliminary design, the complete structure and cylinder frame are simulated and analyzed for Stress by CATIA and ANSYS. According to the outcome of the analysis, any corrective actions would be taken.

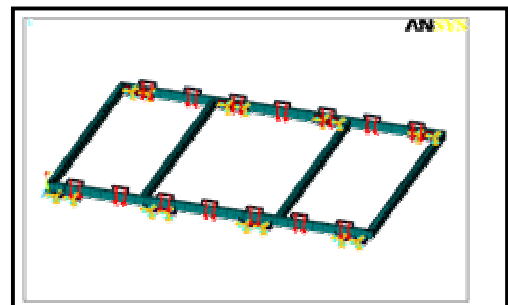
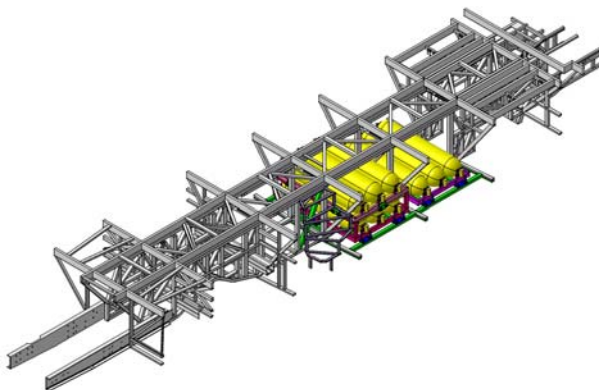

After designing and finalizing of all the in process drawings for Chassis & Frames, they are built by fixtures specially designed for these purposes. Designing and manufacturing of the cylinder cover according to the type of the Frame, Cylinder, the Dept. is capable of designing and making of any cylinder cover using the composite or steel as the material and the installation of the framed cylinders per available standards for cylinder installation and gas burning system for vehicles.

### **Gas circuit**

CNG system means an assembly of components (container(s) or cylinder(s), valves, flexible fuel lines, etc.) and connecting parts (rigid fuel lines, pipes fitting, etc.) fitted on motor vehicles using CNG in their propulsion system. The materials of the components which are in contact with CNG shall be compatible with it.

The gas circuits used in all projects are in the following form and in accordance to VdTUV757 standard and ECER110. The circuit consists of two parts: High Pressure Part and Low Pressure Part. The pressure in H.P part is 200 bar and in L.P. part depends on engine design.

Designing of the Natural Gas piping system using the gas piping system standards for CNG products, we could modify and design any piping system for transferring the natural gas from cylinders to the engine.

Gas piping (the installation of CNG parts on the CNG products) considering the achieved standardized design, the ability to install any CNG components or connectors on the CNG products is available.

Gas leaking tests, after the installation of the frame with the cylinder and CNG parts on the Bus, all the tests for starting a gas burning system per available standards could be preformed.

Regarding the importance of safety in CNG vehicles, following the standards in the under mentioned operation is mandatory:

- Selection of CNG- system parts.
- Pre-assembly of parts according to instructions.
- Design & installation of the CNG gas circuit.
- Gas leakage test before engine start with N2 gas.
- Gas leakage test with CNG gas at working pressure.

### Chart of a CNG system:

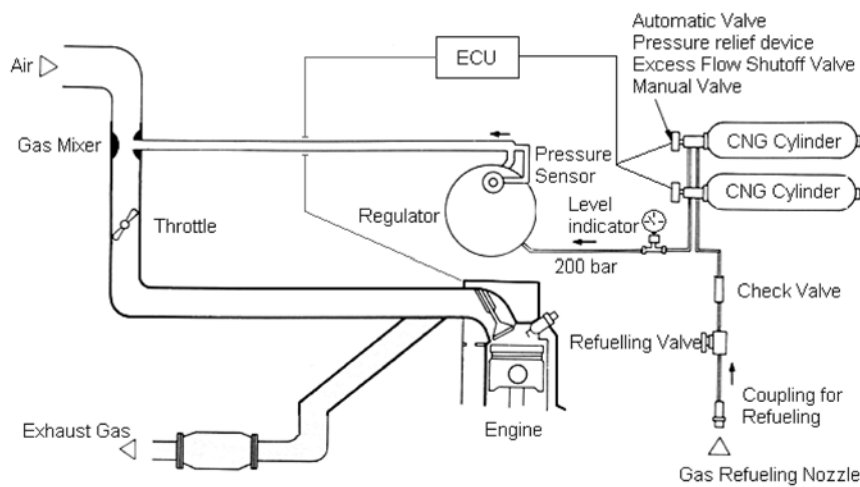

Installation instructions shall be provided to ensure that the cylinders will not suffer unacceptable damage during installation and during normal operation over the intended service life. Where the mounting is specified by the manufacturer, the instructions shall contain where relevant, details such as mounting design, the use of resilient gasket materials, the correct tightening torques and avoidance of direct exposure of the cylinder to an environment of chemical and mechanical contacts.

Where the mounting is not specified by the manufacturer, the manufacturer shall draw the purchaser's attention to possible long term impacts of the vehicle mounting system, for example: vehicle body movements and cylinder expansion / contraction in the pressure and temperature conditions of service. Where applicable, the purchaser's attention shall be drawn to the need to provide installations such that liquids or solids cannot be collected to cause cylinder material damage.

### Fuel selection system and electrical installation

The electrical components of the CNG system shall be protected against overloads.

Vehicles with more than one fuel system shall have a fuel selection system to ensure that no more than one fuel is supplied to the engine at any time.

The electrical connections and components in the gas-tight housing shall be constructed such that no sparks are generated.

The following diagram shows schematically CNG gas circuit in the vehicles in accordance to VdTUV757 standard.

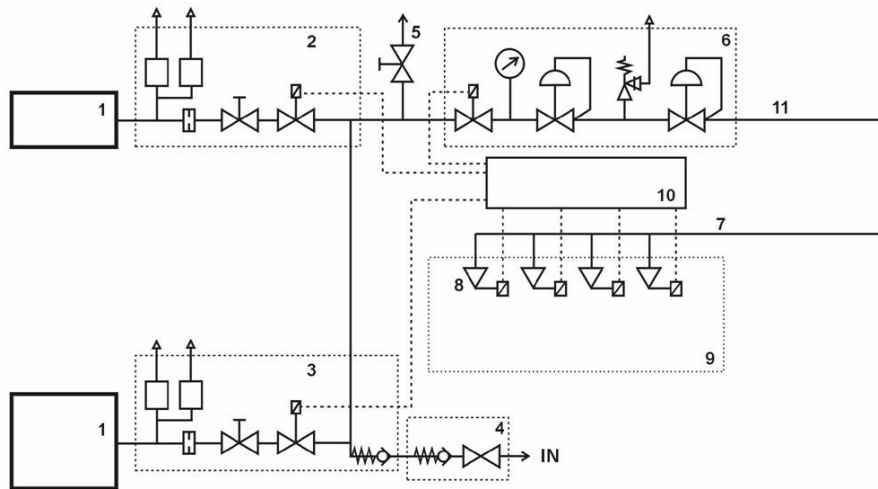

Row	R
1,3	Cylinder *)
1,2	Cylinder
4	Filling Valve „EUROPE“
5	Valve
6	Pressure Regulator
7	CNG Injection Rail
8	CNG Valve-Intake
9	Flange
10	Electronic Control Unit
11	Pipe

### Approval of vehicles, installation of components

- The container shall be permanently installed in the vehicle and shall not be installed in the engine compartment.
- The container shall be installed such that there is no metal to metal contact, with the exception of the fixing points of the container(s).
- When the vehicle is ready for use the fuel container shall not be less than 200 mm above the road surface. No component of the CNG system shall be located within 100 mm of the exhaust or similar heat source, unless such components are adequately shielded against heat.

The fuel container(s) or cylinder(s) must be mounted and fixed so that the following accelerations can be absorbed (without damage occurring) when the containers are full:

Category of vehicle	In direction of travel	horizontally perpendicular to the direction of travel
M1 and N1	20g	8g
M2 and N2	10g	5g
M3 and N3	6,6g	5g

### SAFETY

General requirements for the installation:

- The CNG system of the vehicle shall function in a good and safe manner at the working pressure for which it has been designed and approved.
- The materials used in the system shall be suitable for use with CNG.
- All components of the system shall be fastened in a proper way.
- The CNG system shall show no leaks, i.e. stay bubble-free for 3 minutes.
- The CNG system shall be installed such that it has the best possible protection against damage, such as damage due to moving vehicle components, collision, grit or due to the loading or unloading of the vehicle or the shifting of those loads.
- No appliances shall be connected to the CNG system other than those strictly required for the proper operation of the engine of the motor vehicle.
- Identification of CNG-fuelled vehicles of categories M2 and M3 \*/.
- The plate shall be installed on the front and rear of the vehicle of category M2 or M3 and on the outside of the doors on the right-hand side.

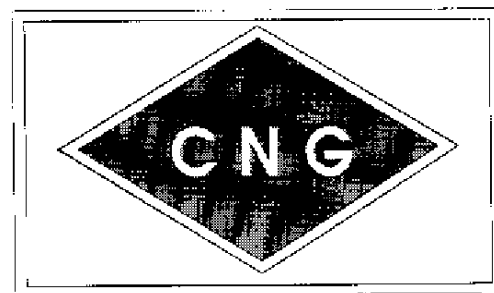

**Periodic tests:**

Offering the season's inspections instruction manual to CNG vehicles workshop.

**References**

1. "Environment problems reviewing in some countries", IFCO- 2001, TD17.
2. IFCO, Iranian Fuel Conservation Organization – CNG site – NGV plan.