

MPRA

Munich Personal RePEc Archive

Energy Power, Digital Infrastructure and Elearning Platforms: Afrfrican Experience.

GODWIN NWAOBI

QUANTITATIVE ECONOMIC RESEARCH BUREAU, P.O.BOX
7173, ABA, NIGERIA

15. October 2008

Online at <http://mpra.ub.uni-muenchen.de/11136/>

MPRA Paper No. 11136, posted 16. October 2008 01:54 UTC

**ENERGY POWER, DIGITAL INFRASTRUCTURE AND
ELEARNING PLATFORMS: AFRICAN EXPERIENCE**

GODWIN CHUKWUDUM NWAOBI

PROFESSOR OF ECONOMICS/RESEARCH DIRECTOR

gcnwaobi@quanterb.org

info@quanterb.org

+234-8035925021

www.quanterb.org

QUANTITATIVE ECONOMIC RESEARCH BUREAU

P.O. BOX 7173

ABA, NIGERIA

WEST AFRICA

ABSTRACT

Information and communication technologies are one of the most pervasive technologies in the world, second only to 'human intelligence' or the human brain. Thus, understating the factors that determine the diffusion of new technologies (ICT) across African countries is important to understanding the process of economic development. And whereas, energy is linked with the capacity to perform, the rate at which energy is consumed for the acceleration of the pace of socio-economic activities is regarded as power. Consequently, it will be obvious that the magnitude of the standard of living in any society; the growth and development of such an economy; and its ability to affect the course of events (such as ICT revolution) will be a function of the extent to which its energy resources are developed and utilized. This paper therefore argued for the need to provide assistance in reducing vulnerability and building the capacity of African counties to more widely reap the benefits of the clean development mechanism in areas such as the development of cleaner and renewable energies. Inevitably, this is the critical condition for the sustainability of the emergent e-learning platforms in Africa.

KEY WORDS: ICT, LEARNING, EARNING, DEVELOPMENT, ENERGY, POWER, INFORMATION, COMMUNICATION, SOLAR, ELECTRICITY, WIND, GOVERNANCE, AFRICA, ELECTRONICS, TELECOMMUNICATIONS, INTERNET, DIGITAL, SATELLITE, RENEWABLE ENERGY, GAS TURBINE, POWER PLANTS, BANDWIDTH, COAL, HDRO, BIOMASS, STEAM, TRANSMISSION, DISTRIBUTION, UTILIZATION

JEL NO: D80, 030, 033, Q40, Q30, A20, I20

1.0 INTRODUCTION

Recent developments in the fields of communications and information technology are indeed revolutionary in nature. Thus, information and knowledge are expanding in quantity and accessibility. Although, the technological revolution in information technology and telecommunications has aroused much interest among policy makers, the business sector, the media and the academic world in the industrialized countries, little is known about the obstacles to accessing information technology and the diffusion and use of information technologies in developing economies, particularly the low-income economies such as African economies. The views on the possible impact of the information revolution on African countries can be grouped in two opposing schools of thought. The first school predicts that as African countries in cut as increasing 'technological deficit', the welfare gap between them and the industrialized world would increase. That is, Africa risks further reduction in its ability to generate the resources necessary to accelerate its growth rate and reverse the trend of increasing poverty. However, another school believes that information technology may actually help reduce the income gaps between rich and poor countries (Negroponte, 1998). Here, the basic issue separating the two schools with regard to the impact of information technology on African countries is the question of whether Africa could have adequate access to the global information infrastructure as well as information technology age.

Indeed, African countries face structural constraints that reflect their market, institutional, technological and infrastructure development. Market failures and limited absorptive capacity are severe and pervasive. Educational, research and extension institutions are slow to respond to new generic technologies. Public educational institutions are hampered by civil service constraints and weak incentives, which limit their market orientation and the quality of their technology diffusion services. Institutions for technology information, assessment, and quality assurance are often absent (and where established) they are slow to recognize new technologies. Private training, local support, and consulting services contribute to IT diffusion but are often limited to short-term, vendor or package-specific training and are typically of poor quality. Again, large IT-user companies can obtain expensive foreign technology consulting services but SMEs cannot and they lack the know-how necessary to help local users adapt and use technology. Critically, African countries are poor in infrastructures that are critical to IT diffusion. The development the development of specialized electronic networks is constrained by the wire liability and inflexibility of the telecommunications infrastructure, poor regulatory framework and lack of standardization and coordination.

Specifically, unreliable power adds to the cost of ICT use in Africa. Modern ICT companies are very much dependent on the quality of electrical power. This is because of the fact that the amount of electrical electronic equipment that is sensitive to the quality of electrical power and used by these companies has increased. In fact, some of this new equipment are automation and are highly

sensitive to power fluctuations. Brief power fluctuations can affect these controls and devices, resulting in nuisance tripping or malfunction of critical process equipment. A typical African firm experiences power failure or voltage fluctuations several times per week, without the benefit of a prior warning; and this imposes a huge cost on the firm arising from idle workers, materials spoilage, lost output, damage to equipment and restart costs. Indeed, the supply side of electricity is one of the critical problems that confront African economics as they pursue different strategies of development under a wide range of political regimes and economic conditions. Thus, electricity is needed for many of the technologies which can be used to enhance teaching and learning.

Essentially, the use of ICTs relies on electricity and, in this respect; most of the African countries (and particularly their rural areas) are at a disadvantage because of the limited extent of their rational grids although alternatives such as solar power, are being explored their viability is hampered by their cost. Again, electricity prices often do not reflect actual costs because of the use of cross-subsidies. The reliance of ICTs on electricity further adds to the complexity of the 'trade-off between the utilities' financial viability and social, economic, and environmental objectives, each of which has to be carefully assessed. However, the power requirements of ICTs will continue to increase and electricity costs will form a considerable part of education and other budgets allocated to be provision of ICTs in African countries. In other words, electricity is extremely relevant to internet and broadband development, as end-user terminals such as computer require which more power than mobile phones. While telephone networks and use has not been stopped by the lack of public power infrastructure (though the lack of it has increased cost and slowed speed of network development), further interest and broadband development and geographical spread will depend on increasing national electrification as a pre-condition.

Again, there are several important links between electricity supply and telecommunications. Obviously, the lack of electricity supply raises telecommunications network cost significantly and there is often potential for shared backbone infrastructure. Power poles and ducts can carry optical fibre alongside the power cables at low marginal cost and community capacities developed by local participation in distributed electricity generation (such as solar or micro-hydro schemes) could lead to community demand for communication facilities. As people generally give higher priority to electricity supply than to telecommunications, one might logically expect that electricity supply would arrive in a community first; and when this happens, telecommunications follow more easily. However, the reverse is often true. Network operators install base stations complete with their own primary generators and people show great ingenuity in keeping their mobile phones charged. Ideally piecemeal ways of supplying power to terminals and network equipment would not be needed. And yet, whether telecommunication provision and electricity generation and transmission can be coordinated in desirable way depends upon local circumstances.

Indeed, the capacity of a national or regional system of innovation for building the capabilities required to take advantage of ICTs is a reflection of the

nature of the 'learning economy that exists in developing countries. Here, ICTs should not be regarded as a potential substitute for human skills or tacit knowledge. Nevertheless, the use of ICTs can offer an important complementary component of the national information infrastructure leading to capability building and enhanced learning throughout the economy.

Essentially, major transformations are occurring in the formal education sector and other organizations that play a key role in enabling people to develop new capabilities. These observed changes are partly the result of the increasing use of ICTs as enabling technologies for education and learning. The extension of more affordable communication networks enables networks among communities of interest supporting the exchange of scientific and technical information as well as sharing knowledge about all aspects of business and everyday life. In other words, the application of ICTs is leading to more flexible learning environments. The feasibility of interactive learning (between teachers and learners, between computer-based software applications and learners, and among teachers and learners) is becoming a reality for some people in developed and developing countries (Mansell and Wehi, 1998; Nwaobi, 2000).

Specifically, the use of ICTs in support of formal and informal education offers the potential to strengthen the capabilities of the populations in African countries with the expectation that this, in turn, will strengthen the science and technology base. However, this potential can only be exploited if the formal and informal education processes in Africa allow people to acquire the skills that are necessary to use new technologies creatively and productively. This daunting task cannot be left solely to the education and training opportunities offered by the manufacturing and services firms in the business sector. Therefore, the thrust of this paper is to analyze the subject matter in question and recommend appropriate policy reform measures for Africa. The rest of this paper is divided into six sections. Section two reviews the African economy and democratic governance. Energy and power sector analysis is presented in section three while section four focuses on the digital and electronic infrastructures the learning platform networks are discussed in section five. Again, section six proposes the policy reform measures and section seven concludes the paper.

2.0 AFRICAN ECONOMY AND DEMOCRATIC GOVERNANCE

Africa continent is commonly divided along the line of the Sahara desert (world's largest desert) which cuts a huge swath through the northern half of the continent. Culturally, Africans are perhaps the most diverse of any continent's inhabitants, with

thousands of ethnic groups and more than one thousands different languages. With ethnicities that often cross national boundaries and continual political upheavals, African national identity is not as strong as racial ties or local kin group affiliations. Traditionally, the vast majority of Africans have been farmers and herders who raised crops and livestock for subsistence. Here, manufacturing and crafts were carried on as part-times activities. A few states developed long distance trade systems and in these places complex exchange facilities as well as industrial specialization, communication networks, and elaborate governmental structures maintained the flow of commerce. But overall, trade in Africa was limited by transportation and communication difficulties and by differences in currency and other incompatibilities.

With European colonization, there was existence of overseas demand for certain agricultural and mineral products and internal labor migration. Here, a new and safer transportation system was constructed as well as the introduction of European technology and crops. Consequently, a modern exchange economy evolved. However, at independence, Africans had high hopes of rapid development and new energies were released by the ending of colonialism. In this era, industrialization was believed to be the engine of economic growth and the key to transforming traditional economics while agriculture was relegated to the secondary role of supplying raw materials and providing tax revenues to finance other development. To complement these strategies, African leaders believed that the government had to play the dominant role and much was achieved. Unfortunately, as at 1970s, the advanced countries began to stumble and by the middle of the decade, Africans performance had fallen below that of other developing countries. In fact, Africa generally poor performance during this period, has been reflected in weak growth in the productive sectors, poor export performance, mounting debt, deteriorating social conditions, environmental degradation and increasing decay of institutional capacity some other reasons for the regions economic decline were attributed to other factors beyond Africa's control. These include bad weather weak world commodity prices, fluctuating international interest rates as well as too little aid. Others blame policies such as poor management of public resources and inappropriate incentives. Yet, others recognize the importance of structural factors such as high population growth (World bank, 1998; Nwaobi 1999).

Unfortunately, the various partnerships between Africa and the industrialized countries on the one hand, and multilateral institution on the other hand, have not yielded the expected development for the fifty –five nations of Africa. The existing partnerships or initiatives include the United Nations New Agenda for the development of Africa; the Africa-Europe summit's; IMF-Led poverty reduction strategy papers (PRSPS); Japan-Led Tokyo Agenda for action; African growth and opportunity Act (AGOA); Economic commission for Africa; Un millennium Declaration; G8 Okinawa Declaration; Copenhagen Declaration; Skagen Declaration; Cotonou agreement; TIKAD; SINO-African process; Generalized system of preferences (GSP); Everything but Arms (EBA) and so on. However, the most recent formation is the New Partnership for Africa's development (NEPAD). Its mission is not to replace or compete with the above initiatives, but rather to establish linkages and synergies between the new and old initiatives. This plan, conceived and

developed by African leaders was described as holistic, comprehensive integrated, strategic framework of Africa. It addresses key social, economic and political priorities in a coherent and balanced manner. It states the vision for the continent and clarifies the problems facing Africa and a program of action to resolve these problems in order to attain the vision. These leaders have pledged their commitment to accelerate the integration of Africa into the global economy. However, the vision and commitment of African leaders to the ideals and principles of political and economic cooperation, as a means of mitigating the development constraints were failed by the existence of many small-nation economics. Consequently, this led then to, among other initiatives, creates the Organization of African Unity (OAU) and the African Development Bank (ADB) as instruments for fostering African development and unity. Much later, this commitment was reiterated in the Lagos plan of action, and subsequently in the Abuja Treaty which envisions the ultimate creation of the African Economic Community.

Indeed, as independent assessment of the impact of Africa's initial efforts to integrate, suggests that the expected benefits have eluded the continent. Equally note worthy, is the absence of any significant change in the structure of the African economics and exports are still confounded to basic mineral and primary products. Again, there is no clear evidence of a causal link between the proliferation of regional and sub-regional institutions and the development of regional infrastructure.

Notwithstanding the dismal outcome from the first generation of integration initiatives, African countries have shown renewed and keen interest in reinvigorating their integration efforts. This has been influenced by rising trends of globalization and deepening regional integration with demonstrable gains in trade, investment and economic growth in purpose, with America and Asia. Thus, there is a rising realization among African countries that progressive integration holds great potentials for minimizing the costs of market fragmentation, and therefore represents a precondition for integrating African economies into the global economy. Here, most countries are undertaking wide-ranging economic reforms and opening their economies through extensive trade and exchange system liberalization. Again, the new integration initiatives are broadening the objectives of economic cooperation and regional integration to include and emphasize the coordination and harmonization of macro economic policies; lowering of trade tariffs; the removal of some non-tariff barriers to trade; facilitation of capital mobility; free movement of persons and business environment improvement. More recently, the constitutive act of the African Union originated in June, 2000 at Accra, Togo with the signatures of the fifty three head of state and government of the member states of the Organization of African Unity (OAU). However, African leaders converged in Lusaka, Zambia, for the 37th and final assembly of the OAU Head of State and Government (in July, 2001) where the organization was noted out of existence. In its place, the constitutive Act of the newly formed Africa Union was formally ratified. As the African Union comes into force, the continents' leaders have agreed that integration on the continent could be enhanced if collaboration is pursued within the framework of regional development strategies that favor member nations. Subsequently, the first summit of the African Union took place in Durban, South Africa (July, 2002) with

lofty promises of a new era of economic development and good government on a continent plagued by poverty and oppression.

Fortunately; in recent times, many African economies appear to have turned the corner and moved to a path of faster and steadier economic growth. Their performance over 1995 – 2005 reverses the collapses over 1975-1985 and the stagnations over 1985 -1995. And for the first time in three decades, African economies are growing with the rest of the world.

Tables 2.1 and 2.2 confirm this fact. Luck certainly has been a factor and global economic growth has been steady over the last ten years. Global trade has expanded and foreign direct investment docketed with private equity funds scouring the globe for new opportunities. Emerging stock markets have also been burgeoning, with global investors searching for high returns. Policies have also been getting better and thus inflation, budget deficits, exchange rates foreign debt payments are more manageable. These economies are also more open to trade and private enterprise. Governance is also on the mend, with more democracies and assaults on corruption. However, because of Aids, tuberculosis, malaria, and other diseases, improvements in life expectancy have stalled in some countries, retreated in a few others. And despite substantial progress in primary enrollments, educational outcomes are not improving as quickly as they might. Poor health and poor schooling naturally hold back improvements in people's productivity and the chances of meeting the millennium development goals.

Indeed, the volatility of growth (a product of conflict, governance and world commodity prices) has been greater than in any other region. That volatility has dampened expectations and investments; and obscured some periods of good performance for some countries. Here, the pickups in growth were seldom sustained and often followed by ferocious declines Hence, Africa's flat economic performance over 1975 – 2005. Where an economy started in 1975 is pretty much where it ended in 2005 (world bank, 2007). The observed Africa's growth deficit is the product of low productivity and low investment. Some growth accounting shows that physical capital per worker has grown less than half the world average. Capital shrank between 1990 and 2003, mirroring low capital investment. And yet, the main culprit in Africa's disappointing growth is total factor productivity, negative since the 1960s (Bosworth and Collins, 2003). Here, a central lesson of Africa's growth experience is that "policy and governance matter a great deal. In other words, Africa today enjoys better growth prospects because its leaders have undertaken major reforms over the past ten years. However, Africa's success in restoring growth is beginning to reveal some emerging constraints to future growth. Infrastructure across the continent is under stress. Skills to build and sustain competitive enterprises are lacking. And the many small and land-locked economies face unique challenges that can be addressed only through effective regional integration African agriculture (long neglected) may also emerge as a constraint to growth in some economies. As an illustration, Nigeria ranked as the sixth largest exporter of crude oil in the world and blessed with vast fertile land and long stretch of waters, it rated 20th in the 2007 Global Hunger Index, indicating that 65% of its 140 million populations go to bed hungry everyday. Today, ranked as the 20th poorest country in the world, with over

70% of her citizenly surviving on less than one United States of America dollar (USDI) a day, the international food policy research institute, in its latest Global Hunger Index (2007) categories Nigeria as a giant unable to feed its population. Today after the gregarious attempts at rejuvenating the sector: zero duty on agricultural machinery, pioneer status incentive of three-year tax holiday doe agro-processing industries; export inventive, ban of some imported food items, the various agricultural policies and programmes and claims to improved food production, the observed problem still persists: why are Nigerians still very hungry? Unfortunately, the same question applies to other Afri can economies.

TABLE 2.1: COMPARATIVE AFRICAN ECONOMIES DATA

S/N	COUNTRY	REGIONAL A INCOME PROFILE	TOTAL B POPULATION (MILLIONS) 2006	RURAL C POPULATION (MILLIONS) 2003-05	VOICE & D ACCOUNT ABILITY 2006	LAND AROA E THOUSANDS (SQKM) 2005	GNI F PER CAPI
1.	ANGOLA	SALI	16	07.30	-1.30	1,247	937
2.	BENIN	WALI	09	04.90	0.30	0.30	111
3.	BOBWANA	SALIMI	-	-	0.60	567	4,559
4.	BURKINA FASO	WALI	14	10.50	-0.30	274	260
5.	BURUNDI	EALI	08	06.06	-1.00	26	105
6.	CAMEROON	CALI	17	07.40	-1.00	465	739
7.	CAPE VERDE	WALMI	-	-	0.90	04	1,343
8.	CENTRAL AFRICAN REP.	CALI	04	02.50	-1.10	623	227
9.	CHAD	CALI	10	07.10	-1.40	1,259	286
10.	COMOROS	EALI	-	-	-0.30	02	386
11.	CONGO.DEM. REP.	CALI	59	38.20	-1.60	2,267	91
12.	CONGO. REP.	CALI	04	01.60	-1.10	342	994
13.	COTE DIVOIRE	WALI	18	09.90	-1.40	318	564
14.	DJIBOUT	SALMI	-	-	-1.00	23	798
15.	EQUATORIAL GUINEA	CAUMI	-	-	-1.80	28	7,533
16.	ERITREA	EALI	05	03.40	-1.80	101	172
17.	ETHIOPIA	EALI	73	58.90	-1.10	1,000	146
18.	GABON	CAUMI	-	-	-1.00	258	3,991
19.	GAMBIA, THE	WALI	-	-	-0.90	10	335
20.	GHANA	WALI	23	11.50	0.40	228	288
21.	GUINEA	WALI	09	06.00	-1.20	246	385
22.	GUINEA BISSAU	WALI	-	-	-0.40	28	135
23.	KENYA	EALI	35	26.60	-0.20	569	442
24.	LESOTHO	EALI	-	-	0.30	30	547
25.	LIBERA	WALI	-	-	-0.60	96	135
26.	MADAGASCAR	EALI	19	13.30	-0.10	582	233
27.	MALAWI	EALI	13	10.50	-0.30	94	154
28.	MALI	WALI	14	08.40	0.30	1,220	244
29.	MAURITANIA	WALI	03	01.80	-1.00	1,025	429
30.	MAUROTUIS	SAUMI	-	-	0.90	02	4,404
31.	MOZAM BIOUE	EALI	20	12.90	-0.10	784	288
32.	NAMIBIA	SALMI	02	01.30	0.40	823	2,096
33.	NIGER	WALI	14	11.20	-0.20	1,267	158
34.	NIGERIA	WALI	145	72.70	-0.80	911	456
35.	RWANDA	EALI	09	07.30	-1.10	25	260
36.	SAO TOME AND PRINCIPE	CALI	-	-	0.30	01	-
37.	SENEGAL	WALI	12	06.70	-0.10	193	503
38.	SEYCHELLES	SAUMI	--	-	0.10	00	6,666
39.	SIERRA LEONE	WALI	06	03.20	-0.40	72	217
40.	SOMALIA	EALI	-	-	-2.10	627	-
41.	SOUTH AFRICA	SAUMI	47	19.10	0.60	1,214	3,429
42.	SUDAN	EASLI	37	21.40	-1.80	2,376	462
43.	SWAZILAND	SALMI	-	-	-1.10	17	1,381
44.	TANZANIA	EALI	39	28.60	-0.30	884	325
45.	TOGO	WALI	06	03.60	-1.20	54	241

46.	UGANDA	EALI	30	24.40	-0.50	197	270
47.	ZAMBIA	SALI	12	07.50	-0.30	743	351
48.	ZIMBABWE	SALI	13	08.30	-1.60	387	432
49.	ALGERIA	NALMI	33	12.10	-0.80	2,382	2,121
50.	EGYPT	NALMI	75	41.60	-1.10	995	1,617
51.	LIBYA	NAUMI	-	-	-1.90	1,760	6,904
52.	MOROCCO	NALMI	30	12.50	-0.60	446	1,356
53.	TUNISIA	NALMI	10	03.50	-1.20	155	2,412
54.	MAYOTTE	SAUMI	-	-	-	-	-
55.	ZMRE	SALI	-	-	-	-	-

S/N	CARBON DIOXIDE G EMISSIONS PER CAPITA (METRKTON) 2002	POLITICAL H STABILITY (NON-VOCERE) 2006	GOVERNMENT I EFFECTIVENESS 2006	ECONOMIC J MANAGEMENT 2006	CORRUPTION K CONTROL 2006
1.	5.10	-0.50	-1.20	2.7	-1.1
2.	0.30	0.40	-0.50	4.0	-0.8
3.	-	1.20	0.70	-	0.8
4.	0.10	-0.20	-0.80	4.3	-0.4
5.	0.00	-1.40	-1.30	3.2	-1.1
6.	0.20	-0.20	-0.90	3.5	-0.9
7.	-	-0.90	0.20	4.3	0.7
8.	0.10	-1.70	-1.40	2.5	-1.1
9.	0.00	-1.80	-1.40	3.0	-1.2
10.	-	10.20	-1.70	2.0	-0.6
11.	0.00	-2.30	-1.60	3.2	-1.4
12.	0.04	-1.00	-1.30	2.8	-1.1
13.	0.30	-2.10	-1.40	1.8	-1.2
14.	-	-0.20	-1.00	2.8	-0.7
15.	-	-0.20	-1.30	-	-1.5
16.	0.20	-0.90	-1.20	2.2	-0.2
17.	0.10	-1.80	-0.60	3.5	-0.6
18.	-	0.10	-0.60	-	-0.8
19.	-	0.20	-0.70	3.0	-0.6
20.	0.40	0.20	0.10	4.2	0.1
21.	0.20	-1.70	-1.40	2.7	-1.0
22.	-	-1.70	-1.40	2.7	-1.0
23.	0.30	-1.10	-0.70	4.2	-1.0
24.	-	0.20	-0.30	4.0	-0.1
25.	-	-1.20	-1.40	-	-0.9
26.	0.10	0.10	-0.20	3.5	-0.3
27.	0.10	0.00	-0.90	3.2	-0.7
28.	0.00	0.00	-0.40	4.3	-0.6
29.	0.90	-0.30	-0.60	3.3	-0.6
30.	-	0.90	0.60	-	0.4
31.	0.10	0.50	-0.30	4.2	-0.6
32.	1.20	0.80	0.10	-	0.2
33.	0.10	-0.40	-0.80	3.7	-1.0
34.	0.40	-2.00	-1.00	4.0	-1.3
35.	0.10	-0.50	-0.40	3.8	-0.1
36.	-	0.50	-0.90	2.8	-0.5
37.	0.40	-0.30	-0.20	4.0	-0.4
38.	-	1.10	-0.10	-	0.1
39.	0.10	-0.50	-1.10	3.7	-1.2
40.	-	-2.80	-2.20	-	-1.8
41.	7.90	-0.10	0.80	-	0.6
42.	0.30	-2.20	-1.10	2.7	-1.1
43.	-	-0.10	-0.70	-	-0.5
44.	0.10	-0.20	-0.30	4.5	-0.4
45.	0.40	-0.90	-1.60	2.0	-1.0
46.	0.10	-1.20	-0.50	4.5	-0.7
47.	0.20	0.30	-0.70	3.7	-0.8
48.	0.90	-1.20	-1.50	1.0	-1.4
49.	5.10	-0.90	-0.40	-	-0.4
50.	2.00	-0.90	-0.40	-	-0.4
51.	-	0.20	-0.90	-	-0.9
52.	1.30	-0.30	0.00	-	0.1

53.	2.10	0.20	0.60	-	0.2
54.	-	-	-	-	-
55.	-	-	-	-	-

NOTES:

- (1) SA = South Africa; EA = East Africa; WA = West Africa; NA = North Africa; CA = Central Africa; UMI = Upper middle income; LMI = Lower middle income; LI = Lower income.
- (2) The Rural population data refers to the average of or the period shown.
- (3) The rating scale for each criterion ranges from – 2.5 (weak performance) to 2.5 (very high performance).
- (4) The Rating scale for Economic management ranges from (1) Low to (6) high. This indicator index is the average of macroeconomic management index, fiscal policy index and debt policy index.

SOURCES:

- (1) World Development Report (2008)
- (2) African Development Indicators (2007)
- (3) World Development Indicators (2003)

Democratic governance is essential to inclusive, equitable human development. It gives people the potential to drive change and exercise choice so as to improve their own lives. Table I.I reveals some of the African democratic status. Thus, a democratic polity needs institutions that work, including a competent civil service focused on serving its citizens as elected parliament that keeps the executive in check, and an independent/professional justice system that provides legal access to all empowering poor citizens by increasing their influence in policymaking and aligning their interests with those of the non-poor can hold politicians more accountable for universal service delivery. Elections, informed voting and other traditional voice mechanism should be strengthened, because these processes (and the information they generate) can make political commitments more credible, helping to produce better service outcomes (World Bank, 2004). Unfortunately, rapid democratization has brought representation and liberties, but not rapid improvements in services for poor people. Most, if not all, new democracies are low-income countries with substantial poverty; services available to poor people in these young democracies (such as African countries) seem to be not much different from those available in non-democracies. In some cases services are worse than those provided by ideologically committed but non elected governments in single party, socialist countries. Therefore, whether countries have elections or not seems not to matter for public perceptions of corruption, and since corruption worsens service delivery for people, by implication for public perceptions of effective services.

In sum, while many African countries have made significant progress in human development with some of the people being lifted out of the poverty every year, violent conflict, lack of resources, insufficient coordination and weak policies continue to show down development (as shown in tables 2.1 and 2.2)

TABLE 2.2: COMPARATIVE WORLD ECONOMIES DATA

S/NO	REGIONAL CLASIFICTION	A POPULATION MILLIONS 2006	B SURFACE AREA THOUSAND SQ.KM 2001	C GNI & PER CAPITA	D GIP PER CAPITA % GROWTH 2005/2006	E CARBON DIOXIDE EMISSIONS PER CAPITA METERXTONS 2003
1.	LOW INCOME	2403	34,246	1,562.3	6.1	0.8
2.	LOWER MIDDLE INCOME	2276	45,811	4,635.2	7.9	2.9
3.	UPPER MIDDLE INCOME	810	21,413	4,789.7	4.9	5.3
4.	EAST ASIA/PACIFIC	1,900	16,301	3,539.1	8.6	2.8
5.	EUROPE/CENTRAL ASIA	460	24,168	2,205.8	6.8	6.8
6.	LATIN AMERICAN/CARIB	556	20,460	2,650.3	4.2	2.4
7.	MIDDLE EAST/NORTH AFRICA	311	11,135	771.2	3.6	3.4
8.	SOUTH ASIA	1,493	5,140	1,142.7	6.9	1.0
9.	SUB-SAHARAN AFRICA	770	24,267	648.3	3.2	0.7
10.	HIGH INCOME	1,029	23,414	37,528.9	2.6	12.8

NOTES

- (1) The Gross National Income (GNI) was calculated using the World Bank atlas method.
- (2) GDP = Gross domestic product

SOURCES:

- (1) World Development Indicators (2008)
- (2) African Development Indicators (2007)
- (3) Word Development Indicators (2003)

3.0**ENERGY (POWER) SECTOR**

The earth is about Five Billion years old, and life on earth is estimated to have begun about three Billion years ago. Historical records date back only about Six Thousand

Years. In fact, the humans social and cultural development, their distinction and detachment from other animals; have been made possible by the exploitation of energy sources. Thus, energy is the primary and most Universal Measure of all kinds of work by human beings and nature. The human use of energy dates from the discovery and creation of fire (some eight thousand years ago). This command of energy became basic for survival in many parts of the world when the last ice age forced an adjustment to colder climates and to foods that required cooking (Schwaller and Gilberti, 1996). The development of settlements into cities increased the use of fuel reserves, and the first **"energy crisis"** quickened the collapse of early civilizations as fuel supplies diminished.

Indeed, energy is vital for all living-beings on earth and modern life – style has further increased its importance, since a faster life means faster transport, faster communication and faster manufacturing processes (Thereja and Thereja, 2008). Thus, energy means the capacity for doing work. This energy comes in two forms as Kinetic Energy (Energy of motion) and Potential Energy (Stored energy).

Here, Kinetic Energy is the energy associated with any kind of motion while potential energy or stored energy is the energy associated with matter by virtue of its position (Nwankiti, 1981). Essentially, there are six forms in which energy has been used in man's development: Heat, Mechanical, Chemical, Electrical, Radiant (Solar) and Nuclear Energy.

All these forms are interconvertible and when such conversion occurs no energy is cost. In other – words, the same quantity of Heat (Thermal Energy) will always be converted into the same quantity of Kinetic energy and vice versa. This is known as the First Law of thermodynamics, which states that in any conversion of energy into work, the total energy of the system is the same before and after the conversion. Subsequently, this law became the basis of all technology involving the transformation of energy into useful work. However, the efficiency is less than 100 percent, a fact expressed as the Law of thermodynamics, which apparently states that it is impossible to devise a machine which (working in cycles) will convert all the heat supplied to it into useful work. Thus, the following types of resources are available for generating electrical energy. The conventional methods include thermal and hydro – electric while the non-conventional methods include wind power, fuel cells and photo voltaic – cells.

Here, the thermal energy (from fossil fuels) or nuclear energy used for producing steams for turbines drive the alternators (rotating a. c. generators). For the hydro-electric method, potential of water stored at higher altitudes is utilized as it is passed through water – turbines which drive the alternators. For the wind power method, the high relatives of wind are utilized in driving wind turbines coupled to alternators and it has the main advantage of having zero production cost.

Here, the cost of the equipment and the limit of generating – unit – rating is suitable for a particular location are the important constraints. This method is pollution free and renewable, and it is available in plentiful quantity (at certain places). Fuel cells

are devices which enable direct conversion of energy chemically into electrical form. It is an up – coming technology that is pollution – free and noise free. The photo voltaic cells directly converts solar energy into electrical energy through a chemical action taking place in solar cells, and it operates based on the photo – voltaic effect, which develops an emf on absorption of ionizing radiation from sun. While selecting a method of generating electricity, the following factors are taking into account: initial cost, running cost, limitations, perpetuity, efficiency, reliability, cleanliness and simplicity.

However, the thermal (coal, gas, nuclear) and hydro – generations are the main conventional methods of generation of electrical energy. They enjoy the advantages of reaching perfections in technologies for these processes; and further single units rated at large power – outputs can be manufactured along with main components, auxiliaries and switch – gear. Indeed, these are efficient and economical. Yet, they appear numerous disadvantages. The fuels are likely to be depleted in near future; toxic, hazardous fumes and residues pollute the environment; overall conversion efficiency poor; high maintenance costs; and high transmission cost. On the other – hand, the non – conventional energy sources have the following advantages: non – polluting processes; perpetuity and renewability of the main source; and virtually zero running cost. However, they are disadvantageous due to high initial cost (per MW of installed capacity) and due to weather uncertainty (such as dense clouds, night hours and still – air). **It is important to note that solar energy can also be used for generating electrical energy through an intermediate stage of producing steam, which is used later for driving an alternator.**

When electricity leaves the power plant, its voltage is increased at a step – up transformer and the electricity travels along a transmission line to the area where power is needed. There, in the substation, voltage is decreased with the help of step – down transformer. Again, the transmission lines carry the electricity as it reaches the final consumption points. In other words, by transmission and distribution of electric power, is meant its conveyance from the central station where it is generated to places where it is demanded by the consumers (like mills, factories, residential buildings, commercial buildings, pumping stations and so on. Here, electric power may be transmitted by two methods: overhead system or underground system. In the over – head system, power is conveyed by bare conductors of copper or aluminum which are string between wooden or steel poles erected at convenient distances along a route, while the underground system employs insulated cables which may be single, double or triple – core and so on. It is important to note that these days all production or power is as a. c. power and nearly all d. c. power is obtained from large a. c. power systems by using converting machinery like synchronous or rotary converters, solid – state converters and motor – generator sets.

The conductor system by means of which electric power is conveyed from a generating station to the consumers remises may be divided into two distinct parts: transmission system and distribution system. Each part can again be sub – divided

into two: primary transmission/secondary transmission as well as primary distribution/secondary distribution. Subsequently, there is a system of supply to individual consumers. In the central station, power is generated by 3 – phase alternators at 6.6 or 11 or 13.2 or 32KV. This voltage is then stepped up by the suitable 3 – phase transformers for transmission purposes. Assuming the generated voltage is 11KV, the 3 – phase transformers step it up to 132KV; which is the voltage carried by the primary or high voltage transmission. This requires conductors of smaller cross – section which results in economy of copper or aluminum.

Next, the 3 – phase, 3 – wire over head high – voltage terminates in step – down transformer in a sub – station known as receiving station (R. S.) which usually lies at the outskirts of a city, and here the voltage is stepped down to 33KV.

From the receiving station, power is next transmitted at 33KV by underground cables or over head lines to various sub – stations (SS) located at the various strategic points in the city, and this is known as secondary or low – voltage transmission. At the sub – station (SS) voltage is reduced from 33KV to 3.3KV 3 – wire for primary distribution. On the other hand, the secondary distribution is done at 400/230V for which purpose voltage is reduced from 3.3KV to 400V at the distribution sub – stations. This low – voltage distribution system is further sub – divided into feeders, distributors and service means. Here, no consumer is given direct connection from the feeders; instead consumers are connected to distribution network through their service means. Again, it is common practice to interconnect many types of generating stations by means of a common electrical network and operate them all in parallel. This combination of generating stations forms what is known as power system and the various elements of such a system like generating stations, transmission lines, substations, feeders and distributors become tied into a whole by the integrated process of continuous generation and consumption of electric energy. In other words, that part of power system which consists of the sub – stations and transmission lines of various voltage rating is called a **system network or grid**.

Indeed, the power system network which generally concerns the common man is the distribution network of 11KV lines or feeders downstream of the 33KV sub – station. Here, each 11KV feeder branches further into several subsidiary 11KV feeders to carry power close to the load points, by further stepping down to either 230V or 415V. Unfortunately, this structure of the distribution feeders does not support quick fault detection, isolation of faulty regions and restoration of supply to the maximum outage area (that is healthy). In the absence of switches at different points in the distribution network, the only option available is the circuit breaker. Using this as a tool for load management is not desirable, as it disconnects the power supply to a very large segment of consumers. Thus, lack of information at the base station (33KV sub – station) of the loading and health status of the 11KV/415V distribution transformers and associated feeders is one primary cause of inefficient power distribution.

Again due to absence of monitoring, overloading occurs, which results in low voltage at the customer end and increases the risk of frequent breakdowns of transformers and feeders.

Consequently, to enhance the electrical power distribution reliability, sectionalizing switches are provided along with circuit breaker and protective relays at the distribution sub – stations, the system is capable to determine fault sections. To reduce the service disruption area in case of power failure, normally open (No) sectionalizing switches called as route (tie) switches are used for supply restoration process. The operation of these switches is controlled from the control center through the Remote Terminal Units (RTUs).

All the functions of data collection, data transmission, data monitoring, data processing, man – machine interface are realized using an integrated distribution SCADA (Supervisory Control and Data Acquisition) system. The implementation of SCADA system in the electric utility involves the installation of the following units (sectionalizing switches, remote terminal unit, data acquisition system, communication interface and control computer).

Essentially, a good data communication system to transmit the control commands and data between distribution control centre (DCC); and a large number of devices remotely located on the distribution network is a pre – requisite for the good performance of Distribution Automation System (DAS). Here, the RTU's communicate with the control room through a communication interface, which could be any of the following: power line carrier communication (PLCC); fibre optics data communication, radio communication, public telephone communication, satellite communication and polling scheme.

Distribution automation functions provide a means to more effectively manage minute by minute continuous operation of a distribution system. It provides a tool to achieve a maximum utilization of the utility's physical plant and to provide the highest quality of service to its customers. Distribution automation systems are modular and thus may be implemented in stages, commencing from a modest degree of capability and complexity and growing as necessary to achieve tangible and intangible economic benefits. It offers an integrated "Distributed Management System (DMS)" and the functions of DMS are shown as follows: Distribution SCADA, Job Management/remote metering, outage management/restoration, load management, load flow calculations, operation management, and distribution SCADA.

Again, energy audit has a very wide range of applications in the electrical systems. Here, it applies to overall accounting of energy generated, transmitted and distributed. As far as distribution side is concerned, energy audit means overall accounting of energy supplied to and utilized by the customers. It can also be used

for rethinking about billing strategy, usefulness of an individual subscriber, loading of a given feeder and so on.

Remote metering is used in energy auditing in which the energy used by a consumer is billed from a remote (distant) location without actually going to the place. Here, the concept of TOD (Time of day) metering can be introduced so that the electronic meters at consumers service entrance point are programmed to read the following meter readings on monthly basis; KW hrs consumed during calendar month by the consumer during low tariff and high tariff hours; KVA maximum demand by the consumer during the calendar month; and low tariff for off peak hour consumption. These readings are telemetered to the control room for the purpose of monthly billing and cash collection through the various modes of communication available depending on the load condition of the consumer.

For the successful running of an electricity production, transmission and distribution system, it is necessary to properly account for the various direct and indirect costs involved, before fixing the final Kwh charges for the consumers. Essentially, the design and construction of an electric power system is undertaken for the purpose of producing electric power to be sold at a profit. Thus, every effort is made to produce the power as cheaply as possible. In general, the cost of producing electric power can be roughly divided into the following two portions: fixed cost and running or operating cost. The fixed cost mainly consists of interest on capital investment, allowance for depreciation, taxes and insurance, salaries and wages; and small portion of fuel cost. The running or operating costs include most of the fuel cost; small portion of salaries and wages; and repair (maintenance). Here, some of the important methods of providing for depreciation are straight – line method, diminishing – value method, retirements – expense method and sinking fund method. Demand factors are used for estimating the proportion of the total connected load which will come on the power plant at one time. Thus, it is defined as the ratio of actual maximum demand made by the load to the rating of the connected load. In other words, demand factor = maximum demand/connected load.

Indeed, the scientific and technological progress of any nation depends on its ability to measure, calculate and estimate the unknown. Therefore, the three ways of making such measurement include mechanical means, electrical means and electronic means. The deflection type instruments with a scale and movable pointer are called analog instruments. Here, the deflection of the pointer is a function of the value of the electrical quantity being measured. On the other hand, the digital instruments are those which use logic circuit and techniques to obtain a measurement and then display it in numerical reading (digital) form.

The particularly the energy demand is rising rapidly with growing population and industrialization. The secondary (usable) energy forms of importance include fuels (coal, petroleum oil, natural gas, chemicals, firewood); Electrical power; chemicals for processes; and renewable (such as solar heat, bio – gas, wind, and bio – mass).

The usable energy is either purchased from energy Supply Company or obtained as free commodity from nature (such as solar heat, wind). Essentially, the energy needs of man vary with life – style, climatic conditions, seasons, industrial progress and so on. The primitive man needed less energy while the rural man of today requires lesser energy than the urban man.

Therefore, the higher per capita energy consumption of a country indicates industrial progress and prosperity. In other words, the energy consumption under the various categories has continued to increase with historic progress of civilizations. This trend is likely to continue for several decades as shown in table 3.1 below. The various primary energy resources are explored; extracted; processed; transported by road/rail/ocean – tankers/river – ships/pipe – lines in liquid or gaseous form alternatively converted into electrical power and then transmitted and distributed in electrical form; and then supplied as fuel, chemicals or electrical power (Rao and Parulekar, 2007).

TABLE 3.1 MAN GROWING ENERGY DEMAND: HISTORICAL REVIEW

HISTORICAL AGE	FOOD	AGRICULTURE	DOMESTIC	INDUSTRY	TRANSPORT	TOTAL
CAVE MAN [1,000,000 YEARS AGO]	3	-	-	-		3
HUNTING MAN [10,000 YEARS AGO]	4	-	3	-		7
AGRICULTURAL MAN [5,000 BC]	5	2	6	-		13
INDUSTRIAL MAN [20 TH CENTURY]	10	5	60	100		260
TECHNOLOGY ADVANCED MAN [21 ST CENTURY]	10	5	60	150		410

NOTES: 1Kwh = 1 Kilo – watt hour = 1000 watt hour = 3.6×10^6 J
 1watt = 1 joule/second = unit of power

1 joule = 1 watt second, unit of energy, unit of work

Per capita = average per inhabitant, per person

However, the choice of particular energy route depends upon the type of primary energy source (recoverable energy); process for conversion to intermediate form; distance between extraction site and consumer centre; techno-economic choice of transportation/transmission; and endues as secondary energy, electrical or non – electrical.

Figure 3.1 shows the various energy routes. The energy routes for various renewable energy resources are as a rule electrical energy routes, that is, renewable energy is converted to electrical form and then distributed and supplied to consumer. The conventional energy resources (except hydro) may have two alternative routes: non – electrical (fuel) route and electrical route. The renewable energy sources like wind, solar heat, waves cannot be stored in original form. It is converted continuously to electrical form, transmitted, distribute d and utilized

Figure 3.1 ENERGY ROUTES

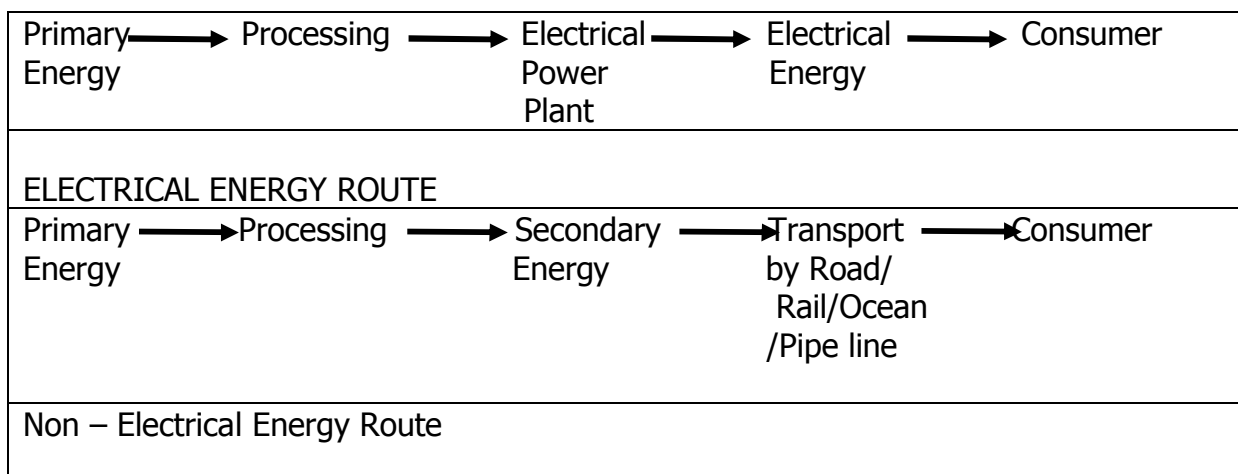

without long-term intermediate storage. The renewable are available free of cost and the consumption of renewable should be maximized. On the other hand, the non-renewable should be conserved for some more decades (centuries).

Table 3.2, 3.3, and 3.4 gives a summary of renewable energy sources and power plants.

During the early years of electrical energy supply systems, small local generating stations supplied power to respective load centers. Here, each generating station needed enough installed capacity to feed the local peak load. However, modern energy supply system is large three phase A.C. electric networks covering certain geographical area. Thus, each individually controlled A.C. Network has its own generating station, transmission and distribution system, connected loads and a load control centre. The load control centre determines the total power generation requirements in the region and allocates the generation (MW) to each power station. This generation is matched with prevailing load (MWe) to maintain the system frequency (50 Hz) within target limits (48.5Hz to 51.5Hz) whereas surplus power is exported or deficit power is imported by the regions. The National grid is formed by the interconnection of the Regional Grids; which is an integral part of the energy supply system as well as energy management system. Here, power plants can be built nearer to the energy deposits and long or medium length transmission lines can be installed to transfer energy in the electrical form from the power plants to the network. Subsequently, the network pools up the energy and distributes over the entire area. The economic power generation and lowest cost of energy is perhaps one of the major advantages of the interconnected network. Unlike the conventional energy forms, electrical energy is generated, transmitted and utilized almost simultaneously without

TABLE 3.2: ENERGY POWER PLANTS: RENEWABLE ALTERNATIVES

S/NO	TYPE	REMARKS
1.	SOLAR-THERMAL STEAM POWER PLANT SOLAR PHOTO-VOLTAIC CELL PANEL POWER PLANT	Boiler installed on tall central tower gets reflected solar irradiation from sun-tracking mirrors on ground level; steam from boilers drives steam turbine-generators; Solar PV CELL PANELS CONNECTED IN SERIES/PARALLEL; Direct conversion into electric energy
2.	WIND-TURBINE-GENERATOR POWER PLANT	Large wind-turbine with three blades, horizontal axis, installed on nacelle on a tall tower; the wind turbine-gears-rotate generate shaft; several wind turbine-generator units (50 KW to
3.	GEO-THERMAL-STEAM THERMAL POWER PLANT OR BINARY CYCLE POWER PLANT	Heat inside earth extracted in form of drysteam/wetsteam/hotbrine through hot deep well (1.5km to 3Km deep); heat used for steam turbine or NH ₃ turbine/Hydrocarbon Turbine; Turbine drives generator; Large base load power plants rated 200MW to 1000MW
4.	OCEAN THERMAL ENERGY CONVERSION POWER PLANT (OTEC)	Heat in upper layer of water used for driving steam turbine/gas turbine on shore or in floating power plant; cold water from bottom of ocean used for condenser.
5.	OCEAN WAVE ENERGY POWER PLANT	Power plants are located in locations with high waves (2 to 4km); waves drive hydro-turbines in cyclic manner during onward wave of during forward/reverse waves; Bulb turbine –generators installed within penstocks located inside long barrages across the ocean – shore.
6.	OCEAN TIDAL ENERGY POWER PLANT	During high tide, water is accumulated in upper reservoir; during the low tides; water from upper reservoir flows to lower level and drives the hydro-turbine generators.
7.	WASTE INCINERATION POWER PLANTS	Located in large sites; combustible waste from the city (paper rags, wood chips, wood dust, residue – waste etc) is used as fuel; the combustion of fuel gives heat. Steam turbines drive generator rating 1 to 10MW; flue gases cleaned before letting into atmosphere.
8.	BIO-FUELS POWER PLANTS	Wood, rice husk wheat husk, bio-gas, special forms with fuel-crops raised in three months, are burnt and used of steam –turbine generators.
9.	FUEL CELLS POWER PLANTS	Chemical liquids, Gases used as fuels and Oxidants ratings few KW to a few MW.

10.	NUCLEAR FUSION POWER PLANTS	Likely to be introduced by 2010, presently research and development work is in progress; combining (fusion) of some lighter nuclei gives heat; likely to serve as major energy resource in future; fuel sources practically unlimited.
11.	MAGNETO HYDRO DYNAMICS (MHD) POWER PLANTS	Hot gases are seeded to form ionized gases. These are passed through strong magnetic field; electrodes held in perpendicular plane collect the current; direct conversion from heat to electricity 14MW plant built: 100 MW, 200 MW plants built, small hydro-electric power plants for villages/farms.
12.	MINI, MICRO HYDRO	Small hydro-electric power plants for villages and farms

TABLE 3.3 TYPES OF POWER PLANTS FOR BASE LOAD, PEAKING LOAD

LOAD CATEGORY	STATION TYPE	REMARKS
BASE LOAD	Coal Fired Steam (Thermal Power Plants) Combined Cycle P. P. Geothermal Steam (Thermal) large hydro-electric	Operated at all times influence overall cost of generation Rs/Mwhr
INTERMEDIATE LOAD	Combined cycle PP Hydro – Electrical PP Less efficient Steam Thermal units	Operated at the above base load line
PEAKING LOAD	Gas Turbine PP Hydro-electric PP Pumped storage PP Diesel Electric PP	Operated during peak loads only
ENERGY DISPLACEMENT PLANTS	Wind Power Solar Power, Tidal Power	Whenever, renew-able is available

TABLE 3.4 RENEWABLE OPERATION (BATTERY DIESEL HYBRID POWER PLANTS)

During favorable solar/wind hours	Primary energy from renewable source converted to electrical
During unfavorable solar/wind	Battery – bank supplies electrical energy via conditioner
(With batteries fully charged) (With battery charge exhausted)	Diesel –generator supply power

Intermediate storage in electrical form hence a large electrical network is formed to pool up electrical energy available from various generating stations and to distribute to various consumers over the large geographical area. Consequently consumers draw power as per their load requirement:

Empirically, electricity generation, transmission and distribution account for a very small percent of Africa's gross domestic product (GDP).

In fact, they constitute a small economic activity in Africa, in relation to her size and population. However, it is a growth industry which permitted to operate with minimal government intervention could be a major contribute or to the national economy.

The electric power sub in African is dominated by the government parastatals. They supply most of the electricity consumed and supplemented with power generated from privately-owned plants. In Africa, there is widespread private provision of electricity usually referred to as 'captive power supply'.

In most cases, captive electric power supply has been a response to irregular public power generation and transmission. Before the advent of hydro-generated electricity, electricity supply in African was largely by the thermal system. Recently however, the hydro system has started giving way to the thermal dominated system. This was due to the perennial water flow problem of some rivers of Africa, escalating costs of establishing hydro-plants and their long gestation lags. Unfortunately, electricity generation in African is characterized by excess capacity and inadequate supply. It has been observed that peak demand is often about one-third of installed capacity because of the non-availability of the spare parts and poor maintenance. A poorly-motivated workforce, vandalism and theft of cables and other vital equipment; accidental destruction of distribution lines, illegal connections and resultant over-loading of distributed lines, are additional problems facing African electricity parastatals. In fact, these have been responsible for unannounced load shedding, prolonged and intermittent outages which most consumers have had to contend with.

Table 3.5 and 3.6 presents comparative African and world data of electricity.

The ratio of GDP to energy use provides a measure of energy efficiency. To produce comparable and consistent estimates of real GDP across countries relative to physical inputs to GDP (units of energy use) GDP is converted to international dollars using purchasing power parity (PPP) rates. The differences in this ratio over time and across countries reflect in part structural changes in the economy; changes in the energy efficiency of particular sectors and difference in fuel mixes. The use of energy in general and access to electricity in particular are important in improving people's standard of living. But electricity generation can also damage the environment. Whether such damage occurs depends largely on how electricity is generated. Electricity production is measured at the terminals of all alternator sets in a station. In addition to hydropower, coal, oil gas and nuclear power generation, it covers generation by geothermal, solar, wind and tide and wave energy as well as that from combustible renewable and waste. There, production includes the output of electricity plants designed to produce electricity only as well as that of combined heat and power plants. Access to electricity refers to the number of people with access to electricity as the percentage of the total population. The sources of electricity refer to the inputs

TABLE 3.5 COMPARATIVE AFRICAN ELECTRICITY DATA

A s/n	B Country	C Electricity production billion kwh	D Electricity Access % of population	E Hydro power source (%) 2000	F Coal sources(%) 2000
----------	--------------	---	---	--	---------------------------------

1	ANGOLA (SALMI)	1.40	12.00	63.10	-
2.	BENIN (WALI)	0.10	22.00	-	-
3	BOTSWANA (SAUMI)	-	22.00	-	-
4.	BURKINA FASO (WALI)	-	13.00	-	-
5.	BURUNDI (EALI)	-	-	-	-
6.	CAMEROON (CALMI)	3.50	20.00	98.90	-
7	CAPE VERDE (WALMI)	-	-	-	-
8	CENTRAL AFRICAN REPUBLIC (CALI)	-	-	-	-
9	CHAD (CALI)	-	-	-	-
10	COMOROS (EALI)	-	-	-	-
11	CONGO, DEM, REP (CALI)	5.50	6.70	99.7	-
12	CONGO REP (CALMI)	0.30	20.90	99.7	-
13	COTE D'VOIRE (WALI)	4.80	50.00	36.6	-
14.	DJIBOUTI (NALMI)	-	-	-	-
15.	EQUATORIAL GUINEA	-	-	-	-
16.	ERITREA (EALI)	-	17.00	-	-
17	ETHIOPIA (EALI)	1.70	4.70	97.50	-
18.	GABON (CAUMI)	1.00	31.00	71.30	-
19	GAMBIA THE (WALI)	-	-	-	-
20	GHANA (WALI)	7.20	45.00	91.70	-
21	GUINEA (WALI)	-	-	-	-
22	GUINEA BISSU (WALI)	-	-	-	-
23.	KENYA (EALI)	3.90	3.90	34.10	-
24	LEASOTHO (EALMI)	-	5.00	-	-
25.	LIBERIA (WALI)	-	-	-	-
26.	MADAGASCAR (EALI)	-	8.00	-	-
27	MALAWI (WALI)	-	-	-	-
28.	MALI (WALI)	-	-	-	-
29.	MAURITANIA (WALI)	-	-	-	-
30	MAUTITIUS (SAUMI)	-	100.00	-	-
31	MOZAMBIQUE (EALI)	7.00	7.20	99.60	-
32	NAMIBIA (SALMI)	1.40	34.00	97.60	0.40
33	NIGER (WALI)	-	-	-	-
34	NIGERIA (WALI)	15.80	40.00	3680	-
35	RWANDA (EALI)	-	-	-	-
36	SAOTOME AND PRINCIPE (CALI)	-	-	-	-
37	SENEGAL (WALI)	1.50	30.10	-	-
38	SEYCHELLES (SAUMI)	-	-	-	-
39	SIERRA LEONE (WALI)	-	-	-	-
40	SOMALIA (EALI)	-	-	-	-
41	SOUTH AFRICA (SAUMI)	207.80	66.10	0.60	93.10
42	SUDAN (EALI)	2.40	30.00	48.30	-
43	SWALILAND (SALMI)	-	-	-	-
44	TANZANIA (EALMI)	2.30	10.50	96.50	-
45	TOGO (WALI)	0.00	9.00	2.20	-
46	UGANDA (EALI)	-	3.70	-	-
47	ZAMBIA (SALI)	7.80	12.00	99.40	0.20
48	ZIMBABWE (SALI)	7.00	39.70	46.60	52.50
49	ALGERIA (NALMI)	25.40	98.00	0.20	-
50	EGYPT, ARAB REP (NALIMI)	75.70	93.80	-	-
51	LIBYA (NAUMI)	20.70	99.80	-	-
52	MOROCCO (NAUMI)	14.10	71.10	5.10	58.10
53	TUNISIA (NALMI)	10.60	94.60	0.60	-
54	MAYOTTE (SAUMI)	-	-	-	-
55	ZAIRE (SALI)	-	-	-	-

CONTINUE OF TABLE 3.5

S/N	G Oil source (%) 2000	H Gas source (%) 2000	I Nuclear power (%) 2000	Electricity consumption per capital Kwh 20000	K Transmission and distribution losses % of output 2000	L GDP per unit of energy use & per kg 2000
-----	--------------------------	-----------------------------	-----------------------------------	--	---	--

1	36.90	-	-	88	15	3.60
2.	100.00	-	-	64	72	2.50
3	-	-	-	-	-	-
4.	-	-	-	-	-	-
5.	-	-	-	-	-	-
6.	1.10	-	-	183	22	3.80
7	-	-	-	-	-	-
8	-	-	-	-	-	-
9	-	-	-	-	-	-
10	-	-	-	-	-	-
11	0.30	-	-	40	04	2.50
12	0.30	-	-	86	60	3.20
13	11.00	52.40	-	-	-	3.60
14.	-	-	-	-	-	-
15.	-	-	-	-	-	-
16.	-	-	-	-	-	-
17	1.40	-	-	22	10	2.60
18.	18.10	10.70	-	697	10	4.70
19	-	-	-	-	-	-
20	8.30	-	-	288	01	5.50
21	-	-	-	-	-	-
22	-	-	-	-	-	-
23.	54.80	-	-	106	22	1.90
24	-	-	-	-	-	-
25.	-	-	-	-	-	-
26.	-	-	-	-	-	-
27	-	-	-	-	-	-
28.	-	-	-	-	-	-
29.	-	-	-	-	-	-
30	-	-	-	-	-	-
31	0.40	0.00	-	53	10	2.50
32	2.10	-	-	-	-	12.00
33	-	-	-	-	-	-
34	6.30	56.90	-	81	32	1.20
35	-	-	-	-	-	-
36	-	-	-	-	-	-
37	99.90	0.10	-	121	17	4.50
38	-	-	-	-	-	-
39	-	-	-	-	-	-
40	-	-	-	-	-	-
41	-	-	-	3,745	08	4.40
42	51.70	-	-	66	15	3.80
43	-	-	-	-	-	-
44	3.50	-	-	56	22	1.10
45	97.80	-	-	-	-	4.90
46	-	-	-	-	-	-
47	0.40	-	-	556	03	1.20
48	0.90	-	-	845	21	3.10
49	3.00	96.70	-	612	16	6.40
50	16.10	65.20	-	976	12	4.80
51	100.00	-	-	3,921	-	-
52	36.40	-	-	447	06	9.50
53	12.10	87.10	-	939	11	7.40
54	-	-	-	-	-	-
55	-	-	-	-	-	-

SOURCE: WORLD AFRICAN DEVELOPMENT (2007)
WORLD BANK WORD DEVELOPMENT (2003)
WANTED NATION HUMAN DEVELOPMENT REPORT (2006)
IEA'S WORLD ENERGY OUTLOOK (2002)

NOTES: KWH = KILOWATH PER HOUR
 SHARE MAY NOT SUM UP TO 100 PERCENT BECAUSE SOME
 SOURCE OF GENERATED ELECTRICITY (SUCH AS WIND, SOLAR AND
 GEOTHERMAL) ARE NOT SHOWN

TABLE 3.6 COMPARATIVE WORLD ELECTRICITY DATA

A s/n	B Region	C Electricity production billion kwh	D Electricity Access % of population	E Hydro power source (%) 2000	F Coal sources(%) 2000
1	LOW INCOME	1,144.7	37.40	21.40	45.00
2.	LOWER MIDDLE INCOME	3,429.3	93.80	18.40	47.00
3	UPPER MIDDLE INCOME	1,347.9	94.70	41.50	19.20
4.	EAST ASIA AND PACIFIC	1,722.1	87.30	-	66.20
5.	EUROPE AND CENTREAL ASIA	1,827.5	-	17.10	31.40
6.	LAPN AMERICA AND LARRIBEAN	973.2	86.60	60.20	4.70
7	MIDDLE EAST AND NORTH AFRICA	481.9	90.40	9.10	1.70
8	SOUTH ASIA	634.8	40.80	15.30	66.20
9	SUB-SAHARAN AFRICA	282.4	24.60	-	69.80
10	HIGH INCOME	9,424.6	-	-	38.40

CONTINUE OF TABLE 3.6

S/N	G Oil source (%) 2000	H Gas source (%) 2000	I Nuclear power (%) 2000	Electricity consumption per capital Kwh 20000	K Transmission and distribution losses % of output 2000	L GDP per unit of energy use & per kg 2000
1	8.50	16.20	8.60	352	22	4.0
2.	7.30	21.30	5.40	1193	10	3.7
3	19.10	18.40	5.40	2252	14	4.9
4.	5.60	9.30	1`.00	760	8	-
5.	4.80	30.70	15.70	2,753	13	2.3
6.	17.60	13.50	2.10	1,528	16	6.1
7	42.50	46.70	-	1,346	12	3.8
8	5.80	9.40	3.00	323	26	5.5
9	2.90	4.10	4.60	432	10	2.9
10	6.30	16.00	23.70	8617	6	4.9

SOURCE: WORLD BANK AFRICAN DEVELOPMENT INDICATION (2007)
 WORLD BANK WORLD DEVELOPMENT INDICATORS (2003)
 UNITED NATION HUMAN DEVELOPMENT REPORT (2006)
 IEA'S WORLD ENERGY OUTLOOK (2002)

NOTES: Shares may not sum up to 100 percent because
 Some sources of generated electricity such as wind, solar and
 geothermal are not shown.

used to generate electricity: hydropower, coal, oil, gas and nuclear power. The
 electric power consumption measures the production of power plants and combined
 heat and power plants less transmission, distribution and transformation losses and
 own use by heat and power plants. The electric power transmission and distribute

losses are losses in transmission between sources of supply and points of distribution and in distribution to consumers, including pilferage, clearly, the empirical data confirms that African countries are energetically deficient for any development progress.

Consequently, the ECOWAS authority has taken steps to ensure that the implementation of the West African power pool (WAPP) Project is an accelerated and well coordinated. This has led to the establishment of WAPP as an organization. The Headquarters agreement between the governments of the republic of Benin WAPP secretariat for its location in Cotonou has been prepared and signed accordingly. Since its inception, the WAPP secretariat has undertaken a diverse range of activities and these include a business plan (2006-2009). This plan incorporates the implementation strategy to be pursued in realizing the WAPP infrastructure programme of approximately \$16 billion up to the year 2020.

The programme mainly involves electric power grid interconnections and development of strategic generation resources in West Africa. In the area of capacity building, the WAPP secretariat has formed partnerships with institutions such as US Edison Electric Institute, Korea Electric Power Corporation, General Electric and Tokyo Electric Power Company. WAPP has also established contact with funding sources such as Equivera Capital (South Africa) and KOICA (Korea) to complement the on-going efforts to secure grants from the African Growth Catalytic fund and the ACP-EU energy facility yet, the challenges faced by the electricity sub-sector in West Africa, especially the unpredictability of fuel prices have been cause for concern and call for improvement in the efficiency of activities. The WAPP secretariat has therefore formed a task force to formulate a mitigating strategy that would seek to increase collaboration between oil producers, refineries and utilities again, the challenges of the shortage in electricity supply and the unpredictability of fuel prices, have been cause for concern and call for improvement in the efficiency of utilities and their operating environment. The successful evolution of the WAPP relies among others on the healthy well-being of its members to allow for their effective participation on the activities of the WAPP. And yet, the inflexibility of tariffs to respond to the associated increase in operating costs remains the biggest constraint facing the utilities in effectively participating in the WAPP activities.

The First Nigerian electric power plant started operation in 189 with the establishment of Ijora Power station (Lagos). This was followed by the construction of the hydro-plant in Kuru falls (Jos) and established by Nigerian Electricity supply company (NESCO). In 1950, the Electricity Corporation of Nigeria (ECN) was formed to integrate power development and took over the isolated power plants at Ijora, Oji, Delta and Afam. The Niger Dam Authority (NDA) was set up in 1960 to build and manage damson Nigeria for greater efficiency, both the ECN and NDA were merge to form National Electric Power Authority Decree No. 24 of April 1, 1972. It was formed as a vertically integrated power utility outfit responsible for generation, transmission, distribution and electricity sells. Thus, NEPA was given the mandate to maintain an efficient coordinated and economic system of electricity supply to all parts of the nation and to propel the nation's technological and industrial growth. Indeed, NEPA made giant strides in the production and marketing of electricity to the nation and beyond. A principal beneficiary of NEPA's extended electricity

programme is the Republic of Niger under the agreement with NIGERLEC (Niger Electric Company). Also an undertaking was signed between NEPA and Comminute Electricque Du Benin (CEB) that is responsible for the production and transmission of electric energy in the Republic of Benin and Togo. However, NEPA faced multitude of operational challenges: ever- rising consumer debts, vandalization of NEPA installations, high cost of maintenance, inadequate gas supply, low water level at the hydro power stations, high cost of foreign exchange, abysmally low tariff regime, illegal connections and unbridled monumental corruption. Consequently, NEPA was unable to meet its obligation in distribution and marketing stable electricity to its numerous residential, commercial and industrial customers. Table 3.7 show the Nigerian electricity data which reveals the perennial problem of power supply in Nigeria.

Subsequently the federal government decided to unbundled NEPA and allows private sector participation in the sector. The signing into law of the Electric Power Sector Reform Act 2005 (March 11, 2005) facilitated the formation of initial holding and successor companies to take over the functions of NEPA and all its assets and liabilities and staff. Thus, POWER HOLDING COMPANY OF NIGERIA (PHCH) was inaugurated as a replacement for NEPA. PHCN is expected top carry out its business and fulfill all its obligations and functions as provided for in the electric power

TABLE 3.7: NIGERIAN ELECTRICITY DATA

A YEAR	B INSTALLED CAPACITY	C TOTAL GENERATION (MEGA WAIT) PER HOUR	D CAPACITY UTILIZED (%)	E INDUSTRIAL CONSUMPTION MEGA WAIT PER HOUR	F COMMERCIAL
1970	804.7	176.6	21.90	91.40	-
1971	804.7	215.4	26.80	114.90	-
1972	786.7	255.4	32.50	138.20	-
1973	670.6	299.7	44.70	146.10	-
1974	721.0	261.1	36.20	163.20	-
1975	926.2	395.4	42.70	200.40	-
1976	1125.2	468.7	41.70	214.60	-
1977	1114.2	538.0	48.30	253.00	-
1978	1793.7	522.7	29.10	157.70	93.50
1979	2,230.6	710.7	31.90	160.30	77.90
1980	2,230.5	815.1	36.50	199.70	94.10
1981	2,430.0	887.7	36.50	121.00	21.30
1982	2,902.1	973.9	33.60	262.00	79.10
1983	2,856.8	994.6	34.80	254.40	84.30
1984	3,178.0	1,025.5	32.30	217.20	81.60
1985	3,695.5	1,166.8	31.60	259.80	85.60
1986	4,016.0	1,228.9	30.60	280.50	85.60
1987	4,548.0	1,286.0	28.30	294.10	90.20
1988	4,548.0	1,330.4	29.30	291.10	118.60
1989	4,584.0	1,462.7	32.20	257.90	195.30
1990	4,548.0	1,536.9	33.80	230.10	217.60
1991	4,548.0	1,617.2	35.60	253.70	254.10
1992	4,580.0	1,693.4	37.00	245.30	266.10
1993	4,548.6	1,655.8	36.40	237.40	311.60

1994	4,548.6	1,772.9	39.00	233.30	306.70
1995	4,548.6	1,801.1	39.80	218.70	279.60
1996	4,548.6	1,854.2	40.80	235.30	280.00
1997	4,548.6	1,839.8	40.40	236.80	264.50
1998	4,548.6	1,724.9	37.90	218.90	253.90
1999	5,580.0	1,859.8	33.30	191.80	236.80
2000	5,580.0	1,738.3	31.20	223.80	274.70
2001	6,180.0	1,689.9	27.50	241.90	298.30
2002	6,180.0	2,237.3	36.20	146.20	372.60
2003	6,130.0	6,180.0	38.80	196.00	417.90
2004	6,130.0	2,763.6	48.10	398.00	489.30
2005	6,861.6	2,779.3	40.50	182.30	496.60

CONTINUATION OF TABLE 3.7:

YEAR	G RESIDENTIAL CONSUMPTION MEGA WAIT PER HOUR		H TOTAL CONSUMPTION MEGA WAIT PER HOUR		I GENERATION CONSUMED (%)
1970	53.90		145.30		62.30
1971	66.20		181.10		84.00
1972	72.90		211.10		82.60
1973	86.60		232.70		77.60
1974	103.00		266.20		100.00
1975	118.30		318.70		80.60
1976	155.20		369.80		78.90
1977	182.70		435.70		81.00
1978	253.20		504.40		96.50
1979	221.90		480.10		64.70
1980	243.10		536.90		65.90
1981	193.60		335.90		45.10
1982	344.50		685.60		70.00
1983	358.00		696.70		70.00
1984	326.60		625.50		61.00
1985	372.00		717.40		61.50
1986	476.60		841.80		68.50
1987	468.60		852.90		66.30
1988	443.80		853.50		64.20
1989	523.60		978.80		66.80
1990	450.80		898.50		58.50
1991	459.30		946.60		58.50
1992	481.60		993.00		58.60
1993	592.40		1,141.40		68.90
1994	275.00		1,115.00		61.80
1995	552.60		1050.90		59.50
1996	518.00		1033.30		55.70
1997	508.30		1009.60		54.90
1998	500.00		972.80		56.40
1999	455.10		883.70		47.50
2000	518.80		1017.30		58.50
2001	564.50		1104.70		65.40
2002	752.80		1,271.60		56.80
2003	905.60		1,519.50		63.40
2004	938.50		1,825.80		66.10
2005	1,194.30		1,873.1		67.40

SOURCES: CBN STATISTICAL BULLETIN (2006)
POWER HOLDING COMPANY OF NIGERIA (PHCN)

NOTES: - The industrial figures for 1970-1997 include commercial consumption figures total Generation has been converted from million KPH to mega watt per hour and this applies to electricity consumption which was formally in kilowatt per hour.

sector reform act. It is also expected to create successor companies that would be registered as limited liability companies and subsequently privatized. In other words, the cardinal thrust of the reform programme was the introduction of competition and choice to improve efficiency in operations and electricity supply. This reform actually commenced in 2001 with the legal and regulatory renew, which culminated in the preparation of the national electric power policy and electric power sector reform bill. These documents were adopted and enacted in 2001 and 2005 respectively (as already stated). In the intervening period, Bureau of Public Enterprises (BPE) with the Mandate to undertake the reform, worked with NEPA/PHCN and the Federal Ministry of Power and steel in ensuring the successful unbundling of NEPA (Institution of shadow wholesale trading arrangement) and the establishment of the regulatory commission called the Nigerian Electricity Regulatory Commission (NERC).

Indeed empirical investigations have shown that Nigeria did not build any new power station fourteen years before Obasanjo took over in 1999. In fact, the last plant was ejected in 1985 and more worrisome was the fact that only nineteen of the country's seventy-nine generating units were working. And yet, during Obasanjo's eight-year administration, many power stations were built while works are ongoing on several others. In Omotosho Okitipupa local Government area of Ondo State sits a 335 MW power plant. About 200 kilometers west of Omotosho is another gigantic power station at papalaito, Ogun state (335MW). Another station is the 414MW Geregu power plant near Ajaokuta, Kogi State. It is a two phased project that would supply 828MW to the national grid when completed. The Calabar power station is an NIPP project financed through the Federal Ministry of power and steel. It is located in Ikot Nyong, Ikot Ekpere- Calabar federal Highway, Odukpawi L.G.A Cross River State. This contract was awarded to Maruberi Corporation of Japan, who also built the Egbi Power Station in Ikorodu Lagos and the Delta Power Plant. The Calabar station is expected to generate 501MW of electricity and would first be stepped down and shared to Cross River and Akwa Ibom States before connection to the national grid. The Obasanjo government also embarked on the construction of gas turbine at Umobasi Ukwu village Alaiyi, Ugwunagbo LGA, Abia State. On completion, the gas turbine will supply 126MW. The contract was awarded to Rockson Engineering LTD, who also built the Rivers State Independent power project, IPP, Omoku. The six other power stations in Niger Delta include Egbema- Imo State (338MW); Eyaen-Edo (451MW); Gbanian/Ubie- Bayelsa (225MW); Ikot Abasi- Akwa Ibom (300MW); Sapele- Delta (451MW) and Omoku-Rivers (230MW). All these eleven stations have combined capacity of 4144MW. The other commissioned independent power projects

are Aes-Lagos (300MW); AGIP Okpai- Bayelsa State (480MW) and Omoku- Rivers State (150MW). The on going IPPs are Obajan – Kogi State (350MW); Ibom Power (188MW) and Chevron –Lagos (780MW). However, before the new democratic initiative, existing stations were Egbin Lagos State (1320MW); Afam –Rivers State (969.6MW); Sapele – Delta State (1020MW); Delta (912MW); Ijora- Lagos State (40MW); Kainji- Niger State (760MW); Jebba – Kwara State (578.4MW) and Shiroro-Niger (600MW). Therefore the existing total capacity in Nigeria is given as 12,592MW. Unfortunately, the greatest problem militating against maximum output at the commissioned plants is inability to get enough gas to fire the turbines. In fact, the Nigerian Gas company (a subsidiary of NNPC) has been unable to supply enough to its customer especially PHCN recently its 58-kilometer pipeline from escravos to NGC, which supplies gas to the entire country, was vandalized at Igborodo Urhobo, near the Warri Refinery and Petro-chemical company. In the recent past Niger Delta Militants ruptured it and this body affected supplies to PHCN plants. Again after the repair was complete, the vandals struck again. Thus, vandalization of gas pipeline is the major factor supply in Nigeria.

Consequently, President Yar'Adua (of current democratic regime) has set up as 11-man committee for accelerated Expansion of Nigeria's power infrastructure. This body was mandated to deliver additional 6,000MW within Eighteen months through the NIPP as well as add 11,000MW by 2011 through diverse sources. The body is expected to conduct independent technical, financial and legal audit of power infrastructure in the country; source fund to complete on-going NIPP projects, provide in puts for the design of an appropriate securitization structure to attract credible investors to the sector as well as provide inputs for a power purchase agreement template that will ensure a reasonable level of return on investment for investors and affordable tariffs for consumers.

Again, despite the presentation of twenty-seven licenses to promoters of independent power projects (IPPS) by the Nigerian Electricity Regulatory commission (NERC) so as to encourage public-private participation in the development of the nation's power sector; only Kwale power plant (Agip) and Aba Power plant/Geometric power/have recorded significant progress. The promoters of these IPPs have been complaining of inadequate gas supply by oil producing firms as well as in appropriate electricity tariff. However, the approved \$400 Million Securitization fund for these promoters of new power plants. This is designed to forestall market failures by investors after making significant investment in the construction of power stations. This facility is only for the IPP promoters that have proper power purchase agreement and gas sales agreement would be opportune to benefit from the securitization fund which would be maintained by the central Bank of Nigeria, in case of failure during the implementation of the agreement the beneficiaries would draw from the fund through the payment for equipment to manufacture by the CBN so as to enhance adequate maintenance of power stations to prevent breakdown that is associated with the power stations of the Power Holding Company of Nigeria (PHCN). Again, the federation government of Nigeria recently took a major step towards tackling the country challenge in Abuja (August, 2008). When a strategic partnership agreement tagged "Nigeria Germany Energy Partnership Memorandum of Understanding" (MOU) was signed with Germany. Under this agreement, German

firms would execute various power projects nationwide which will lead to the injection of 6,500 mega watts of electricity into the national grid between 2008 and 2020.

Unfortunately, the controversy over the report of the House of Representatives committee on power sector which indicts former President Olusegun Obasanjo and some other public officers may start from among members of the committee. Its presentation to the house has been difficult and is being frustrated by member who threatened to tender a ministry report. This controversial report took several people, contracting firms and agencies to the cleaners. It says that Obasajo government spent the sum of \$13.28 billion (N1, 567 trillion) in the power sector between 1999 and 2007 with unfunded commitment of over \$12 billion (N1, 416 trillion). In other words, the report says that Obasanjo wasted over \$25.28 billion (N2.983 trillion) without making "a difference in the country. In recommending Obasanjo (as well as Central Bank of Nigeria an office of Accountant General of Federation) for further probe, the committee says its finding showed "beyond doubt" that the major problem of the power section under him was not the means to execute projects but efficiency in the management of resources. With the phenomenal revenues accruing to the country from crude oil over the past ten years, resources have never been as generously available as they are in Nigerian history. Yet, huge sums were spent but there was little or nothing to show for the expenditure in terms of extra megawatts of electricity. In general only electricity industry reform without the additional challenge of chronic poor performance is complex on its own. There are policy technical organizational, institutional market designs and regulatory issues to contend with in the electricity industry which make implementation of reform a daunting challenge. It requires clear, unambiguous focus on issues to be addressed, which usually form the impetus for change.

Electronics is among the world's largest and fastest – growing industry. It is embedded in many capital and consumer goods and has altered the cost structures as well as the quality and productivity standards of most other industries. Also, it enables a veritable revolution in communications and information that lies at the root of modern economic development. The output of the electronics industry comprises a wide variety of products, ranging from the most sophisticated computer hardware and software, telecommunications equipment, industrial and military control systems, and medical diagnostic apparatus; to advanced video and audio equipment; to home appliances and a host of lesser consumption items. Table 4.1 shows the classification of electronic products. Electronics is the enabling technology of the information economy. About half the value of the world's production of electronics equipment is in data processing and communications; and information today is regarded as a fundamental factor of production (alongside capital and labor).

The increasing dependence of economic activity on information, coupled with globalization of capital flows, trade, manufacturing and other activities, has resulted in strong demand for better, (more varied) and less costly communications and information services (Wellenius, Miller and Dahlman, 1993). Demand growth has been intertwined with rapid advances in micro electronics, software, and optics. These innovations have greatly reduced the cost of the transmitting and processing information; changed the cost structures of many businesses and made possible new ways of meeting a wider range of information needs. In other words, the competitiveness of any industry is significantly conditioned by its ability to incorporate electronics. Here, a number of mechanical and electromechanical components of capital and durable consumer goods have been replaced by lower – cost more versatile, and compact electronic solutions. For the past three decades.

Worldwide production in the electronics sector has grown faster than in any other industrial sector. This has been associated with rising demand for existing products, introduction of new products, opening of new markets, and increasing penetration of electronics throughout the rest of the economy.

Conventionally, five sub-sectors of electronics are distinguished: telecommunications, computers, industrial, consumer electronics and semi conductors. However, specific enterprises and products shift easily among sub-sectors and all share common requisites for effective utility in the market place. Thus, there is a great deal of synergy among developments in the different sub-sectors and much of the growth in electronics reflects systemic change rather than substitution. In other words, the development of new generations of electronic products is inextricably interwoven with strategic changes in manufacturing, marketing and service, contributing to increased interdependency among sub-sectors.

TABLE 4.1 ELECTRONIC INDUSTRY PRODUCT CATEGORIES

(A) CONSUMER ELECTRONICS

(1) Video Equipment	(2) Audio Equipment	(3) Home Information Equipment	(4) Others
Monochrome TV	Audio components	Home Computers	Electronic Wares
Color Television	Digital Audio	Computer Software	Toys and Games
Advanced Television	Add-on components	Computer accessories	Musical instrument
Projection TV	Packaged Audio Systems	Dedicated word Processors/Typewriters	Children Electronics
Video systems	Audio Accessories	Compact facsimile	Home Security systems
Video cassette Recorders/Players	Audio Tape Equipment	Personal Copies	Health Care Products
Camcorders	Auto sound	Telephones	Calculators
Personal Video	Portable Audio	Cellular Telephone	Cebus or intelligent Home
Still Video Cameras	Radio	Electronic Organizers	
Video Disc Systems		Accessories	
Video Software		Communications	
Videotext systems			
Captioning			
Home Satellite			
Earth Stations			

(B) COMPUTERS AND INDUSTRIAL ELECTRONICS

(1) Computers	(2) Peripheral Equipment	(3) Industrial Automation	(4) Artificial Intelligence	(5) Others
Personal Computers	Storage Equipment	Industrial Controls	Robotics	
Work stations	Optical Disk Technology	Electronic Temperature	Machine Vision	
Mini Computers Super Mini Computers	Computer Terminals	Controls	Materials handling	
Main frames	Printers		Bar Coding	
Mini-super computers Super computers	Software and operating systems		Computer-aided design	
			Computer-aided	

			Manufacturing	
			Computer-aided Engineering	
			Computer-integrated Manufacturing	

(C) COMMUNICATIONS EQUIPMENT

(D) ELECTRONIC COMPONENTS

(1) Main	(2) Networks	(3) Others	(1) Electron Tubes	(2) Solid State Products	(3) Electron Parks
Central Offices	Integrated Systems	Teletext Videotext	Television Picture Tubes	Discrete Semiconductors	Capacitors
Fiber optics	Digital network		Receiving Tubes	Integrated circuits	Resistors
Facsimile	Network Management	Land Mobile	Power and special purpose tubes	Other semiconductor devices	Switches and relays
Microwave Transmission	Systems Local Area Networks	Radio	High vacuum, gas and vapor, and other special purpose tubes		Accessory parts
Telephones Answering Machines	Wide Area Networks				
Cable Television	Value-added Networks		Microwave tubes		Transformers
Cellular Radio	Metro Area Networks				Filters
PBX, Centrx, key stems					Printed-circuit boards
Data communications					Wire and
Modem					Cable

(E) ELECTRONIC RELATED PRODUCTS AND SERVICES

(1) Main	(2) Photographic	(3) Others
Aerospace	Photographic equipment	Toys and Games
Automatic controls	Optical equipment	Clocks and watches
System Integration and computer services		Musical instruments
Motor vehicles		
Electronic-related office equipment		

Changing technology, manufacturing processes and market requirements, along with the redistribution of cost elements for various electronic products, are all significantly changing worldwide and sourcing of electronics. This new parameters open opportunities for developing countries while reducing the viability of traditional options. The same technologies affect the process of design itself and in turn, radically alter manufacturing practices. Market development is also closely interwoven with technological innovation. In particular, it has been argued that the electronics industry is driven primarily by developments in semi conductors, and that silicon semiconductor circuits will continue to be the premier enabler of advances in industrial, commercial and consumer electronics into the next century.

The semiconductor industry is composed of three sub-sectors: semiconductor producers, semiconductor manufacturing equipment and finished semi-conductor distributors. It is one of the most research and development intensive industries; and is also capital intensive. Given such high levels of R & D and capital spending, the industry is also characterized by extremely rapid rates of technological change, both in the design of products and in the processes required to produce them in quantity. The industry continues to be characterized by a high rate of technological change, which as resulted in significant productivity gains. Here, capital costs for entry continue to be high, and continued competitiveness requires on going capital investment for producers of memory, micro processor, and ASIC products. The semiconductor manufacturing processes consist of three steps: water fabrication processing ("front end" of the production process) testing and assembly ("bulk end" of the process).

The invention and use of the computer represents a revolutionary technological leap forward; and a technical advance of extraordinary economic and social significance. Capturing some of the economic gains from continued technological advanced in computers must certainly be one of the major reasons behind the developing countries interest in learning to use and produce computer technology. Historically, computers have been characterized by a high rate of technological progress, heavy research and development (R & D) intensity and extensive involvement of government in technology development. The most productive task for a nation's computer policy is to put computers to work and collect those social returns. That means maximizing the use and applications of computers. The enormous economic benefits of computer are due to steep declines

in computer price-performance being passed on to the computer users. However, the heavy R & D investments traditionally required entering the computer business, and the economies of scale and scope that established producers enjoy in mature markets make it difficult for a new comer to break into the market place. As the price of the computer hardware has continued to drop, the share in total systems cost of providing software and configuring the system has risen. In other words, the most profitable activities within computer companies are not selling the hardware; rather they are providing software and maintenance, and putting together turnkey system "solutions" for computer users needs (Wellenius, Miller and Dahlman, 1993).

Perhaps, the most important point emerging from the history of the computer industry is the central role that people play in transferring and disseminating technology. The key to gaining access to computer technology is getting one's people on the inside of organizations and institutions with demonstrated capability and expertise. Trained people are required to take advantage of such opportunities and investment in educating and training a skilled technical workforce is a prerequisite for such a strategy to work. Thus, investment in technical and educational infrastructure is crucial. However, the key to understanding the telecommunications equipment industry is the relationship between buyer and seller. Yet, this relationship is changing dramatically because of rapid developments in electronics technology and the liberalization of distribution and ownership. Nothing has had the greater impact on the world telecommunications market than the invention of the transistor and subsequent evolution of the micro electronics industry. The ability of electronic components to handle millions of instructions per second and to store billions of bits of information on a postage stamp-sized chip has dramatically transformed the telecommunications industry. Electronic technology has greatly enhanced the functional capabilities of both network and terminal equipment. Here, the introduction of complementary metal oxide semiconductors (CMOS), high electronic mobility transistors (HEMTs), and gallium circuit (GAS LSI) to semiconductor technologies have greatly increased processing speed and quantity at the same time that it has reduced component costs. The steadily improving cost performance curve has extended the application of digital technology to analog-digital conversion, signal processing, band-compression, video processing, statistical multiplexing, and a wide range of functions. The clear advantages of digital technology wave resulted in its broad application in the telecommunications market. Here, the advantages were initially more obvious for high-capacity transmission links characteristic of trunk networks. Consequently, trunk exchanges and long-hand transmission links have been the first to be digitalized.

Satellite systems have generally played a small role in domestic transmission, but that is changing. With the declining cost of earth station equipment and the proliferation of very small aperture terminals (VSATs), satellite technology is increasingly being employed for domestic services. Again, markets for satellite links and VSATs are becoming increasingly popular for private network applications. While satellite and fiber optics are steadily increasing their share of the overall transmission market, digital microwave suppliers are still best positioned for replacement of analog microwave networks. Here, the growth of data

communications market is being driven by several factors. The rapid proliferation of personal computers in the work place is fueling demand for both local area networks (LAN) equipment to attach to internal information resources, and wide area network (WAN) equipment to connect with other offices and remote data bases. Yet one of the more revolutionary developments in telecommunications in recent times has been the advances in mobile radio technology, especially cellular telephone technology. Other important innovations include paging technology, mobile data technology and wireless telephone technology; initially designed to replace the capacity-restricted mobile radio networks for automobiles, cellular has spurred a new industry in itself with no end in sight for growth. Essentially, the developments of broadband services are underpinning the development of e-commerce and access to bandwidth at globally competitive prices is an increasingly important determinant of competitiveness in the global knowledge economy. Therefore, policies that encourage the provision of affordable broadband access to a nation's firms can put them ahead of global competitors; and those that fail to do so risk condemning their economies to secondarily or subordinate roles. Access to broadband networks and services can also make important contributions to the quality of life, in terms of education, health services and social inclusion.

Indeed, there are many forces for change in communications but a handful can be seen as key drivers. Many countries in Africa have opened their markets to competition, leading to substantial infrastructure investment, price declines, greater services diversity and product innovation. There has been an enormous expansion of data traffic compared with voice traffic, and increasing demand for digital networks, leading to a change in network design philosophy from fixed-path circuit switching to variable-path packet switching. Again the traditional consortium approach to cable and satellite investment is being eroded, and with it the traditional settlements system; and new wholesale capacity markets are turning bandwidth into a commodity, with various carriers' carriers and bandwidth exchanges emerging. These and other changes, can be characterized as a transition from a telephony world in which technologies, applications and providers operated in separate "store pipes" to an IP world in which an ever increasing variety of combinations of technologies, applications and providers is possible (as shown in figure 4.1). In this new environment, the regulatory and policy tools from the telephony world are in many cases no longer adequate. Thus, the underlying challenge is to develop new policy and regulatory tools for the new environment. Table 4.2 shows the comparative African ICT data.

Essentially, the size of the internet infrastructure is a good indication of a country's progress towards an information used economy. Unfortunately, Africa's internet infrastructure is the least developed in the world, with an average less than 1 in 100 people having access. However, averages obscure the great diversity of the African content, which is reflected in wide variation in levels of internet use. But measuring the numbers of users is not easy in African countries because many people share accounts; use corporate and acceding networks or visit the rapidly growing number of cyber cafe's telecentres and business services. Furthermore, simply measuring the number of users does not take into account the extent of use.

As a result, new measuring of internet activity is needed to take those factors into account. One indicator that is becoming increasingly popular is to measure the account of international internet bandwidth used by a country or the size of the pipe measured in kilobits per second (kbps) or megabits per second (mbps). Most of the internet traffic in Africa is internationally such that the size of its international traffic compared to population size provides a ready indication of the extent of internet activity in the country. Yet, there are many other regulatory historic and social factors that influence the extent of internet use in Africa.

Specifically, the Authorities of Heads of State and Government on the recommendation of the council of ministers approved the community telecommunications program known as INTECOM 1 (in May 1979) at Dakar. The objective of the program was to improve and expand the sub-regional telecommunication network. Here, the principal objective were to open-up the member states which did not have reliable links with the outsider world; to complete the missing links in the panaftel network in West Africa; to establish microwave links between the capital cities of member states; and to increase telecommunications traffic within ECOWAS.

FIGURE 4.1 CONVERGENT COMMUNICATIONS: TECHNOLOGIES, PROVIDERS AND APPLICATIONS

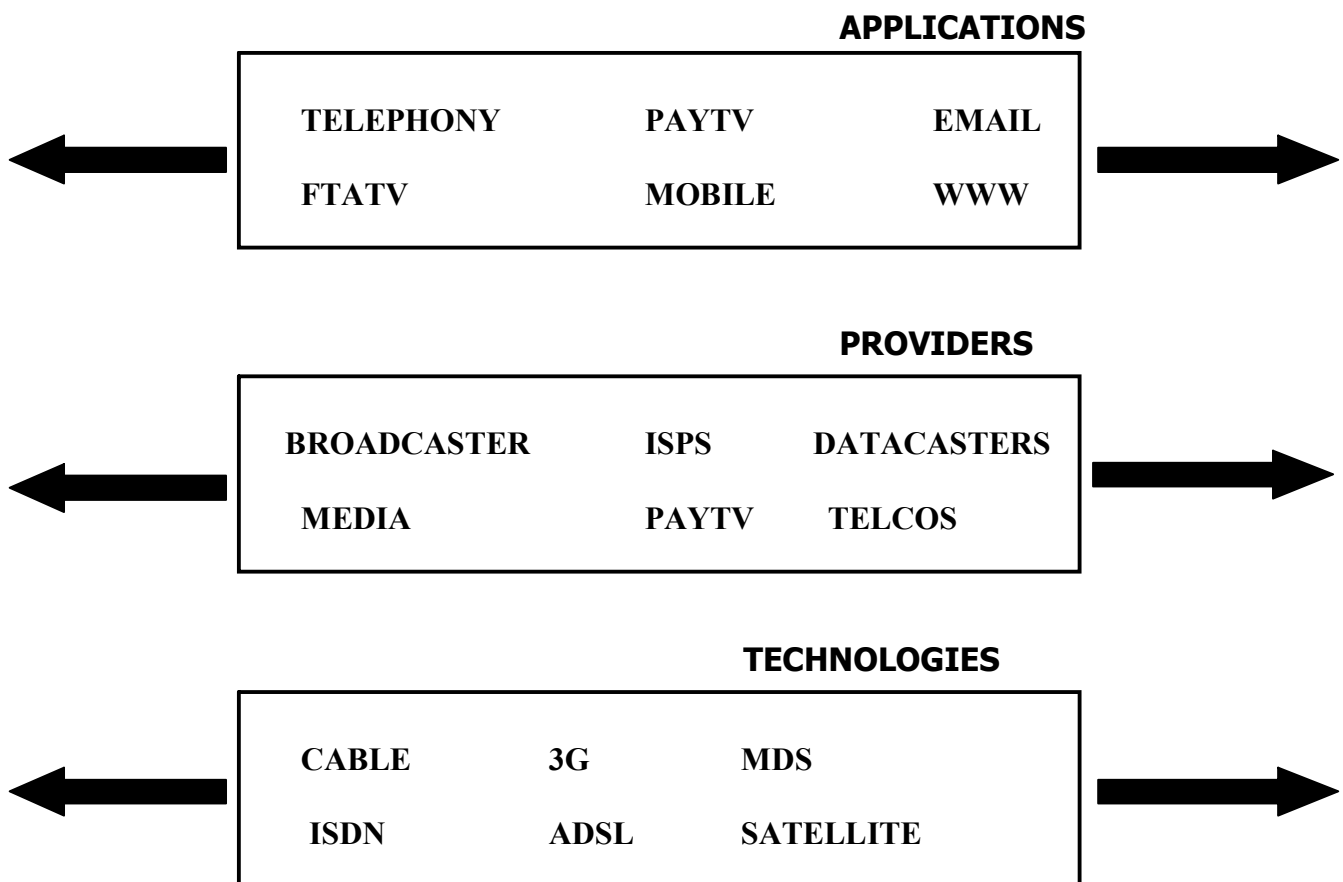

TABLE 4.2 THE COMPARATIVE AFRICAN ICT DATA

A.	B. COUNTRY	C.	D. PRICE	E. TELECOM	F. TELECOM	G. TELECOM ODA	H.	I.
----	------------	----	----------	------------	------------	----------------	----	----

S/N		INTERNET USERS PER 1,000 PEOPLE 2005	BASKET FOR INTERNET \$ PER MONTH 2005	ANNUAL INVESTMENT (\$ MILLIONS) 2005	PRIVATE INVESTMENT (\$ MILLIONS) 2005	DISBURSEMENTS (\$ MILLIONS) 2005		
1.	ANGOLA (SALMI)	11.00	34.30	-	119.80	0.6		
2.	BENIN (WALI)	50.40	20.70	26.40	5.80	0.3		
3.	BOTSWANA (SALMI)	34.00	21.30	19.00	19.00	0.3		
4.	BURKINAFASO (WALI)	4.90	90.60	61.20	5.30	0.3		
5.	BURUNDI (EALI)	5.30	52.00	-	6.00	0.1		
6.	CAMEROON (CALMI)	15.30	44.60	111.20	29.00	0.2		
7.	CAPE VERDE (WALMI)	49.30	40.30	8.90	-	1.0		
8.	CENTRAL AFRICAN REPUBLIC (CALI)	2.70	147.80	0.10	-	0.2		
9.	CHAD (CALI)	4.10	86.30	-	1.40	0.2		
10.	COMOROS (EALI)	33.30	37.90	4.20	-	0.1		
11.	CONGO DEM. REP (CALI)	2.40	93.20	-	42.00	0.5		
12.	CONGO REP. (CALMI)	12.50	84.50	-	7.00	0.0		
13.	COTE D'IVOIRE (WALI)	11.00	67.10	95.20	20.00	0.1		
14.	DJIBOUTI (SALMI)	12.60	41.10	-	-	-		
15.	EQUATORIAL GUINEA (CAUMI)	13.90	32.70	-	-	-		
16.	ERITREA (EALI)	15.90	28.60	17.40	40.00	0.1		
17.	ETHIOPIA (EALI)	2.30	23.30	35.30	-	0.4		
18.	GABON (CAUMI)	48.40	40.10	53.00	9.00	0.2		
19.	GAMBIA, THE (WALI)	-	17.80	3.70	6.60	0.0		
20.	GHANA (WALI)	18.10	23.60	59.40	51.60	0.4		
21.	GUINEA (WALI)	5.30	24.70	0.80	32.60	0.1		
22.	GUINEA-BISSAU (WALI)	19.50	75.00	-	0.60	0.7		
23.	KENYA (EALI)	32.40	75.90	80.50	421.00	1.0		
24.	LESOTHO (EALMI)	-	38.60	7.10	3.00	0.0		
25.	LIBERIA (WALI)	-	-	-	15.80	0.0		
26.	MADAGASCAR (EALI)	5.40	45.90	14.80	12.60	0.2		
27.	MALAWI (EALI)	4.10	41.90	-	0.90	0.4		
28.	MALI (WALI)	4.40	28.40	17.70	82.60	2.7		
29.	MAURITANIA (WALIO)	6.50	54.30	84.70	1.60	0.1		

30.	MAURITIUS (SAUMI)	-	17.50	24.70	25.70	0.1		
31.	MOZAMBIQUE (EALI)	-	32.90	19.70	14.00	9.7		
32.	NAMIBIA (SALMI)	-	48.70	20.50	8.80	0.20		
33.	NIGER (WALI)	2.10	101.80	-	47.20	0.50		
34.	NIGERIA (WALI)	38.00	50.40	386.90	2,312.00	0.50		
35.	RWANDA (EALI)	5.50	31.10	-	33.00	0.00		
36.	SAOTOME AND PRINCIPE (CALI)	-	53.20	2.20	-	0.40		
37.	SENEGAL (WALI)	46.30	25.60	106.0	157.00	6.60		
38.	SEYCHELLES (SAUMI)	248.50	31.50	4.10	14.90	0.00		
39.	SIERRA LEONE (WALI)	10.90	-	-	1.40	0.20		
40.	SOMALIA (EALI)	10.90	-	-	1.40	0.20		
41.	SOUTH AFRICA (SAUMI)	108.80	63.20	871.20	1183.50	7.40		
42.	SUDAN (EALI)	77.30	65.50	128.50	152.00	0.20		
43.	SWAZILAND (SALMI)	-	51.70	27.60	3.00	0.00		
44.	TANZANIA (EALI)	-	93.60	9.40	88.50	0.90		
45.	TOGO (WALI)	48.80	44.70	30.00	-	0.20		
46.	UGANDA (EALI)	17.40	99.60	68.00	77.00	0.70		
47.	ZAMBIA (SALI)	-	68.40	42.50	74.00	0.70		
48.	ZIMBABWE (SALI)	76.90	24.60	21.70	13.00	0.70		
49.	ALGERIA (NALMI)	67.50	5.00	-	1,272.00	-		
50.	EGYPT, ARAP REP (NALMI)	67.50	5.00	-	1,827.00	-		
51.	LIBYA (NAUMI)	-	22.00	-	-	-		
52.	MOROCCO (NALMI)	152.50	26.80	-	626.00	-		
53.	TUNISIA (NALMI)	95.10	12.40	-	106.00	-		
54.	MAYOTTE (SAUMI)	-	-	-	-	-		
	ZAIRE (SALI)	-	-	-	-	-		
	SUB-SAHARAN AFRICAN	29.00	-	21.70	-	17.20		
	NORTH AFRICA	84.80	-	-	-	-		

**SOURCES: WORLD BANK AFRICAN DEVELOPMENT INDICATOR (2007)
UNITED NATIONS HUMAN DEVELOPMENT REPORT (2006)**

Between 1983 and 1992, the community (through the ECOWAS fund) made significant efforts to finance the first program that attends 95% of the initial objectives as confirmed by the evaluation undertaken by the International Telecommunication Union (ITU). The ECOWAS Authority therefore directed the executive secretariat to elaborate and implement a second telecommunications program to be known as INTECOM 11. Its main objective is to provide the

community with a regional telecommunications network that is modern, reliable and capable of offering a wider variety of services, including multimedia and wide band services. This is expected to reduce transits through countries outside Africa and improve direct links between member states. Similarly, the ECOWAS ministers of information and communication (in October 2001 at Bamako) adopted a new information and communication policy. Here, the policy objective was to involve all sectors of the West Africa Public in the integration process. However, the ICT environment in West African region has changed sufficiently to warrant re-conceptualization of the above initiatives. Notably, many new technologies have emerged, especially in the area of wireless communication. At the same time, telephone and internet access in West Africa has increased largely due to private sector intervention. Currently, all West African Countries are now online, and there is at least one private sector telecommunications provider in every country.

The overall objective of the telecommunications programme is the creation of a single liberalized regional telecommunications market. ECOWAS is to ensure this through a regional program that will facilitate the development of a reliable, modern telecommunication infrastructure and harmonize telecommunications policy and legal regulatory frameworks. Recently, a new policy and regulatory framework has been adopted by the ECOWAS ministers in charge of Information and Communication Technology (ICT). This set of draft directives seeks to create conditions that would encourage more competition, promote a more effective regulation of the telecommunications and ICT market. Recently, there has been a re-definition of the role of information and communication technology (ICT) as a cross-cutting enabler for all the regional integration sectors. ECOWAS has initiated the preparation of an ECOWAS ICT policy development and the initiative is aimed at harmonizing existing national policies and assisting member states in formulating and implementing national policies. To this end, a draft working document prepared by a regional expert group was validated by an ICT stake holder's forum and the decision-making bodies of ECOWAS. Particularly, institutional structures have been created and a declaration on ICT for development adopted.

Telecommunications in Nigeria was established in 1886, to promote administrative functions and socio-economic development of the country. Between 1960 and 1985, the management consisted of the department of posts and telecommunication (P & T) and Nigerian External Telecommunications (NET). However, in 1985, the P & T department was split into the postal and telecommunications divisions. The latter was merged with the NET to form Nigerian Telecommunications Limited (NITEL). NITEL main objective was to harmonize the planning and coordination of the internal and external telecommunications services; rationalize investments in telecommunications development and provide easy-access, efficient and affordable services. Much later, the industry was deregulated by the establishment of the Nigerian communications commission (NCC) by decree 75 of 1992, whose main objectives include: creating a regulatory environment for the supply of telecommunication services and facilities; facilitating entry of private entrepreneurs into the market; and promoting fair competition and efficient market conduct among all players in the industry. And yet, the global trend is to evolve

telecommunications policies that integrate the advantages of rapid technological developments in telecommunications, broadcasting, and the global information super highway. Not content with merely licensing service providers with either GSM or code division multiple access (CDMA) capabilities, NCC has raised the stakes for the telecoms industry by introducing a regime of unified license which enables operators to deliver multifarious services under a single platform. Thus, Nigerians can listen to radio on mobile phones which has camera, video recording and internet browsing functions. This unified licensing regime was dictated more by technology and allows the operators to offer fixed services, mobile services, internet services and long distance services using the same frequency to provide all the services. In fact, the possibilities offered by the unified licensing regime are endless. With this regime, people can now browse on their GSM phones and do video streaming; as well as uploading and downloading mails.

Again, many of the mobile operators now have fixed license and some of them have started developing long distance infrastructure which has restricted under the previous regime. The implication is that for one to enjoy mobile services, he does not need to depend on GSM alone. **Most Nigerians now have one GSM line and a CDMA line rather than two GSM phones.** This is seen as being capable of reducing the pressure on GSM services and offer unique pricing levels as low as N20 per minute whereas the GSM services charge close to N40 per minute. The emergence of EVDO technology is an additional growth of the Nigerian Telecom Industry. Table 4.3 and 4.4 shows the Nigerian ICT data.

The communication sector actually improved in 2006, driven mainly by the global system of mobile communication. Foreign investment in the sector increased from \$7,500 million in 2005 to \$8,150 million in June 2006, indicating an increase of 8.7 percent. Again, the number of connected digital mobile lines rose phenomenally by 35.0 percent as at June 2006 compared with the level in 2005. The number of operating internet service providers (ISP) also rose by 50% as at June 2006. Although, there has been a phenomenal growth in telecoms services which are considered essential services, not much has been achieved with the broadband segment. This broadband service is currently being used by businesses and a few individuals as compared to the potential number of users. Therefore, this rate of growth is not commensurate with telephone service. But with the launch of the Nigerian communications satellite (NIGCOMSAT), the growth rate will gradually improve to the level of telephone services so as to reduce the cost of acquisition of broadband. In other words, the NCC has switched its focus to broadband segment and vowed to embark on massive development of the infrastructure.

TABLE 4.3 THE NIGERIAN ICT DATA: GROWTH STATISTICS

S/NO	SOURCE	A. 2000	B. 2001	C. 2002	D. 2003	E. 2004
------	--------	---------	---------	---------	---------	---------

1.	FIXED	553,374	600,321	702,000	888,534	1,027,519
2.	MOBILE	35,000	266,461	1,569,050	3,149,472	9,174,209
3.	TOTAL	588,374	866,782	2,271,050	4,036,006	10,201,728
4.	INTERNET USERS	107,194	153,350	420,000	1,613,258	1,769,661
5.	INTERNET PENETRATION	0.1%	0.1%	0.3%	1.3%	1.5%
6.	NET NEW ADDITIONS FIXED	80,058	46,947	101,679	186,534	138,985
7.	NET NEW ADDITIONS (MOBILE) FIXED	-	231,461	1,302,589	1,580,422	6,024,737
8.	NET NEW ADDITIONS (TOTAL)	80,058	278,408	1,404,268	1,766,956	6,163,722
9.	TELEDENSITY	0.49%	0.72%	1.89%	3.36%	8.50%
10.	FIXED GROWTH %	16.9%	8.5%	16.9%	26.6%	15.6%
11.	MOBILE GROWTH %	0.0%	661.3%	488.8%	100.7%	191.3%
12.	TOTAL GROWTH %	15.7%	47.3%	162.0%	77.8%	152.6%
13.	GROWTH IN INTEREST USERS %	-	43.06%	173.88%	284.11%	9.69%
14.	TELEDENSITY GROWTH %	16.7%	46.9%	162.5%	77.8%	153%

**SOURCES: National Bureau of Statistics, Annual Abstract of Statistics (2006)
Nigerian Communications Commission, Abuja, Nigeria**

TABLE 4.4 THE NIGERIAN ICT DATA: CURRENT MARKET STATISTICS

S/NO	SOURCE	A. 1999	B. 2002	C. 2003	D. 2004	E. 2005	F. 2006
1.	No. of connected fixed lines (000)	450	702	850	1,120	1,223	1,538
2.	No. of connected digital mobile lines (million)	None	1.59	3.10	9.20	18.59	25.14
3.	No. of national carriers	1	2	2	2	2	2
4.	No. of operating ISPs	18	30	35	40	60	90
5.	No. of active licensed fixed line operators	9	16	30	17	20	27
6.	No. of licensed mobile operators	1	4	4	4	4	10
7.	Investment (US \$ millions)	50	2,100	4,000	6,000	7,500	8,150

**SOURCE: Central bank of Nigeria Annual Report and statement of Accounts (2006)
Nigerian communications, Abuja, Nigeria**

NOTE: The data for the year 2006 is reported as at June 2006
The number of licensed mobile operator's data for 2006 includes operators with a unified license, who are licensed to do both fixed and mobile.

To stimulate interest in the use of internet, the NCC has initiated the digital appreciation programme, through which it gives out computers and satellite links to

schools and colleges around the country to get them connected. NCC's schools programme, which is carried out through the universal fund also provides internet access and laptops to school children. The commission has also embarked 'wire Nigeria' programme to increase optic fibre infrastructure around the country to accommodate the envisaged growth in broadband services. Here, the NCC proposes licensing a company to carry out a major optic fibre rollout in the country to assist the operating companies as they go into the next phase of broadband development in the country. All of these are not infrastructure like microwave; but a more robust infrastructure like fibre cable. Thus, with Nigerian connection to SAT 3, NCC is confident that access would be increased to bandwidth internationally and that most of the country's internet traffic will be aggregated locally. But are these efforts necessary and sufficient for the emergent knowledge societies?

Indeed, knowledge is critical for development because everything we do depends on knowledge. The need for African countries to increase their capacity to use knowledge cannot be overstated (Nwaobi, 2000; Nwaobi, 1999) some are catching on, developing national knowledge strategies and catching up. But most need to do much more, much faster, to increase their knowledge base, to invest in educating their people, and to take advantage of the new technologies for acquiring and disseminating knowledge (World Bank, 1999). Thus, countries that postpone these tasks will fall behind those that move faster and the unhappy consequences will be hard to remedy. People, firms, and countries use technical knowledge to improve their efficiency in the production of goods and services. Sometimes, they create that knowledge themselves and at other times, they adopt knowledge created by others. Their decision to create or adopt takes into account the constraints faced. For individuals and for countries, education is the key to creating, adapting and spreading knowledge and it increases people's capacity to learn and to interpret information. Also, higher education and technical training are needed to build a labor force that can keep up with a constant stream of technological advances, which compress product cycles and speed the depreciation of human capital. And outside the classroom, people's working and living environments are the setting for still more learning, well beyond the eyes associated with formal education. As the store of human knowledge continues to grow in size and complexity and to be updated at an ever-faster pace, people need to engage in structured and systematic learning throughout their lives. Therefore, lifelong learning is especially important in African countries, where most adults never received basic education during their youth. Consequently, modern communication technologies allow them to learn at their own pace outside school or the workplace.

Today, a new revolution is in full career, made possible by new technologies that can shuttle vast amounts of information almost anywhere in the world in mere seconds. These advances in communication will enable the construction of whole new societies in cyberspace, linking individuals with common interests to share views and information. However, the use of the new technologies (although growing rapidly) is still limited in Africa. Low income, inadequate human capital, and weak competitive and regulatory environments slow their adoption. Thus, the capacity of a national (or regional) system of innovation for building the capabilities required to take advantage of ICTS is a reflection of the nature of the 'learning economy' that exists in developing countries. Learning capacity is related not only to the sophisticated use of ICTS to access global stocks of knowledge, but to the characteristics of the communication process among people involved in the innovation process. However, ICTS should not be regarded as a potential substitute for human skills or tacit knowledge. Nevertheless, the use of ICTS can offer an important complementary component of the national information infrastructure leading to capability building and enhanced learning throughout the economy. It has been suggested that the current phase of economic development is one in which knowledge and learning are more important than in any other historical period. This is because, regardless of the current capabilities of African countries in the 'learning economy', individuals, firms and even countries will be able to create wealth and obtain access to wealth in proportion to their capacity to learn (Lundvall, 1996). This perspective holds that there is no alternative way to become permanently better off

besides the one of putting learning and knowledge-creation at the centre of the strategy. Between the extremes of generic (codified) knowledge formulated in ways that can be accessed by anyone assuming a certain level of literacy and tacit competence that can be shared with others only through social interaction, there are mixed forms of knowledge an optimistic scenario for African countries in the face of the diffusion of ICTS envisages a massive transfer of tacit knowledge into information systems giving these countries access to new process technologies and products developed in the industrialized countries both rapidly and at low cost. In theory, this is expected to lead to acceleration of the catching-up process and a reduction in global inequalities. However, there are two less optimistic scenarios (Mansell and Wehi, 1998). Firstly, that access to the new knowledge is limited by the absence of capabilities to master the language and codes associated with ICTS. Here, access would be gained only by countries and firms with an appropriately trained labor force. Secondly, that tacit knowledge would play a major role but the application of ICTS would speed up the rate of economic change and stimulate the need for rapid learning, that is, the development of a 'learning economy' would be essential for African countries. Table 5.1 shows the selected African learning date.

Indeed, the extension of more affordable communication networks enables networks among communities of interest supporting the exchange of scientific and technical information as well as sharing knowledge about all aspects of business and everyday life. In fact, the application of ICTS is leading to more flexible learning environments. In other words, the feasibility of interactive learning (between teachers and learners, between computer based software applications and learners, and among teachers and learners themselves) is becoming a reality for some people in African countries. That is, the possibility of continuous informal education and lifelong learning is growing with the increased availability of ICT applications and creativity in their application to address development problems. Here, major changes in formal education systems and institutions as well as the organizations that contribute to informal learning are needed to build new capabilities. The introduction of lifelong learning strategies requires that the foundations of learning be strengthened and changed. It also implies that there must be flexibility for movement between education, training, and work, and new roles for public and private sector institutions that contribute to the learning process. Essentially, the explosion of internet activity and the increasing use of ICTS to support distance education as well as interactive learning in the classroom has suggested that these applications will help to overcome problems of cost and location in the provision of education and training.

**TABLE 5.1 SAMPLED AFRICAN COUNTRIES E-LEARNING PROXY
INDICATORS**

S/NO	COUNTRY	FIXED-LINE AND MOBILE TELEPHONE SUBSCRIBERS (PER 1,000 PEOPLE)			PERSONAL COMPUTERS (PER 1,000 PEOPLE)			INTERNET USERS (PER 1,000 PEOPLE)		
		1990	2000	2005	1990	2000	2005	1995	1999	2005
1	CENTRAL AFRICAN REPUBLIC (CALI)	2	4	27	-	2	3	-	1	3
2	GABON (CAUMI)	22	125	498	-	9	33	-	12	48
3	GHANA (WALI)	3	17	143	0	3	-	0	2	18
4	KENYA (EALI)	8	14	143	0	5	-	0	3	32
5	SENEGAL (WALI)	6	44	171	2	16	21	0	4	46
6	SOUTH AFRICA (SAUMI)	94	302	825	7	66	85	7	55	109
7	UGANDA (EALI)	2	8	56	-	3	9	0	2	17
8	ZIMBABWE (SALI)	12	41	79	0	16	92	0	4	77
9	EGYPT (NALMI)	29	102	325	-	12	38	0	7	68
10	TUNISIA (NALMI)	37	112	692	3	22	57	0	27	95

SOURCES: World Bank African Development Indicators (2007)
World Bank world Development Report (2008)
United Nation Human Development Report (2006)

Here, the content education curricula can be delivered on CD-Rom or diskette or is a satellite links developing software programmes and individual programming from distant centres. Video productions can be circulated among local and international communities; and subject data bases can be accessed remotely. Thus, education and informal community-based initiatives could become 'virtual' and many new opportunities could exist to include students and citizens in the formal and formal education process.

Again, the knowledge networks that support science and technological innovation are becoming increasingly international; and they are involving a growing number of types of research and education institutions. In other words, science and technology research networks are becoming the norm, rather than the exception. Researchers working independently cannot hope to have the full range of skills, equipment and materials needed to carry out modern scientific research (Hicks and Katz, 1996). Rather, scientists are engaged in a continuous learning process involving the recombination of codified information and tacit knowledge to generate new knowledge. The changes in the research process are enabled by ICT applications in a wide range of fields of expertise and they require specific skills in the use and application of ICTS by the research community. The strengthening of

the overall science and technology base in Africa countries is closely associated with the capabilities of the general population. It is being argued that conferences and small discussion groups around computers, surfing the internet, etc are all that is necessary to prepare students for the knowledge societies of the future. Similarly, students prepare papers collectively and they can log onto networks to confer with other students located in foreign countries. Computer-aided instruction is being used to assist in self-learning not only in the classroom but at a distance from the formal classroom. ICTS are being applied to help overcome teacher shortages and serving as a teaching tool for students and teachers as well as developing and upgrading teaching skills. Often, this process is enhanced when electronic communication opportunities exist for teachers, enabling them to exchange both experiences and teaching material. The ICTS network access can also be used to create repositories of study materials that can be transmitted and reproduced at very low cost. Unfortunately, in most African countries, the education systems are resource constrained as shown in the left-hand column of Table 5.2 (Hancock, 1997). The right-hand column shows some of the ways in which the potential benefits of the ICTS applications can help to alleviate these constraints. However, each of the technical solutions assumes that resources are also invested in organizational innovations on a continuous basis.

World population growth poses a tremendous challenge for the ideal of education for all as well as for the provision of opportunities for lifelong learning. Specifically, in Africa it is estimated that nearly one-third of the children who start the first grade will drop out before completing grade four.

Consequently, the **KIDLINK** project provides the means for on-line communication for children between the age 10 to 15 in any country with access to the internet. This project consists of mailing lists, websites and real-time online chat facilities. It aims to prepare children for the global information society and to increase their awareness of responsibility for shaping the future by allowing them to interact and learn in a multicultural, multi-lingual environment regardless of geographical boundaries.

TABLE 5.2 ICTS: LEARNING POTENTIALS

S/N	FACTOR	CONSTRAINTS	TECHNOLOGICAL SOLUTIONS
1	TIME	Teaching and learning have to take place at a particular time repeated for different groups.	Different forms of recording and storage permit on demand.
2.	PLACE	The same teaching module has to be repeated in several locations. Students have to congregate in a designated space.	Communication is made possible over considerable distances. Learning can take place in many locations, including the home.
3	COST	Well-presented teacher-intensive education is called.	Although the claim is often exaggerated, the use of communication technologies can lead to economies of scale.
4	AGE	Many educational processes, structures and opportunities are age-related, favoring the young.	The new technologies can provide learning opportunities for all ages.

5	DIMENSION	Much of the teaching is confined to the individual and the teacher, with limited hands-on experience and exposure to other information.	Technology can enhance visualization and sensory perception.
6	ENVIRONMENT	Learners are inhibited by many barriers, ethnic, cultural, linguistic, physical, etc.	Learning through the new technologies can be customized, drawing on the best planning and teaching resources and a wide range of illustration.
7	ACCESS	Much information is inaccessible (in archives, remote locations, laboratories).	The new technologies can increase accessibility by making information available in user friendly settings and formats.
8	CREATIVITY	Constraints on expression, endemic in many societies, can seriously impair educational processes.	The new technologies encourage creating and freedom of expression by exhibiting a variety of models and learning experiences, and by passing many frontiers which restrict the circulation of ideas.

The Eduvision E-learning system (EELS) is comprised of three separate components: Network operators centrex (NOC), the base station, and eslate. Networked together via the world-space satellite radio network, that covers the entire African and Asian continents; EELS provides a low-cost medium for the transmission of dynamic content anywhere in the African world. Quantitatively, the necessary bandwidth to equip every primary and secondary school child in Africa with EELS would cost less than \$2,000 per month. Again, teachers, principals, superintendents and other education professional are using SMART products to engage students' interest, support learning and encourage interaction in the classroom with multimedia tools at their fingertips; teachers have found creative ways to use the technology to enhance learning. Here, teachers can take their classes on virtual field trips via the internet and can use SMART board software's handwriting-recognition feature to assist elementary students with their writing. By converting cursive writing into block text, young students learn to write in a fun and interactive way. In fact, this SMART Board interactive whiteboard is a powerful touch-sensitive surface to control the computer from the front of the class. And this makes a significant difference in the way technology is used in the classroom. Again, students can respond with increased attention and participation. Of course, one of the biggest challenges for any classroom teacher is capturing students' attention. Thus, the size of the interactive whiteboard and the colorful images that can be displayed can greatly enhance teachers' ability to overcome lethargy in the classroom. Some students can even ask to stay after school to use the interactive whiteboard to work on Math Blaster software which incorporates math problems into games. In this way, students are able to learn team dynamics as well as new technology.

Lectora authority software provides the simplicity and sophistication to develop professional learning courses, presentations, entertain and educate elearners. Lectora is a product of www.trivantis.com. Similarly, Course mill enables

instructors, students and administrators to easily and effectively administer, manage, track, and take online courses and curriculum. It provides student self-enrollment, single click course upload, shopping cart support, wait list functionality and more. It also makes the tracking and reporting of online courses simple and hassle free by enabling users to easily create an unlimited number of reports. Equally, it provides MYSQL database support, 3rd party content support, AKC and SCORN compliance classroom based training support for blended learning, and much more to provide for a range of uses. Other known e-learning networks include Aluka; Avallain AG; Earthwalk; aPals; e-Toys & More; experiential technologies; Fronter AS; Gatlin International; GCFlearn free; Ghana Information Network for knowledge sharing (GINKS); Quantitative Economic Research Bureau, Nigeria (Quarters); Global Development Learning Network; ICDL Africa; icouldbe.org; IICD; INIIT; Interwrite learning; Mindset Network; Ncomputing, Inc; Novoa soft corporation; Open AC; SMSWEB; SPIDER; Toon Boom Animation Inc; Young Digital Planet; WAEup Germany Gbr; Promethean; AIT (University of Future); common sense; BESA; TESSA; BLACKBOARD; QUESTIONMARK; INMEDIA; TECHSMITH; SIVECO; NGONET (provides email access via fidonet throughout Africa); ESANET (Eastern Southern African Network that links researchers in eastern and southern Africa by e-mail); Health Net (a satellite network for exchange of medical information developed by satellite); PADISNET (Pan African Documentation can be Network for a Data and information exchange for planners in 34 countries); WEDNET (a women's project network for the management of natural resources); MANGO (Micro computer Access for NGOS, is an electronic billboard in Zimbabwe); ARSENATE (a Fidonet network supported by Canadian International Development Agency); CABECA (Capacity Building for Electronic Communication in Africa, is funded by IDRC and implemented by the Pan Africa Development in information system of UNECA); RINAF (Regional Informatics Network for Africa, is supported by UNESCO Intergovernmental Information Programme); COPINE (Cooperative Information Network Linking Scientists, Educators and Professionals in Africa is funded by the UN office for outer space to support satellite network connectivity); TELEMANICS (focuses on distance education for the disadvantaged who were previously excluded from education either due to the Apartheid regime or financial constraints and develops specific applications for distance education using Internet and wireless wide-area bandwidth); DIGITAL Publishing; Giuntilabs; its learning; advanced learning solutions; UNESCO-UNEWV TVET; e Degree; Edutel; bit media e-learning solution; GCF Global learning; and so on. Specifically, the African virtual University (AVU) is a pioneer educational and telecommunications network established to serve the countries of sub-Saharan Africa (SSA). It was created to address some of the challenges facing Higher Education in sub-Saharan Africa, such as low enrolment rates and the lack of quality training for the workforce in preparation for participating in the Global Knowledge Economy. AVU provides access to under graduate and postgraduate programs based on prioritized needs of students and education institutions at tertiary level; access to educational materials including e-books, online journals; and other scholarly publications; access to high speed internet services for improved connectivity; and access to information for the African educational community with regard to available distance teaching education, new resources and the best teaching and learning practices. Since inception, AVU has delivered in excess of 3,000 hours of infrastructural programs sourced from leading universities

in North Africa and Europe. It has also provided more than 1,000 PCs to learning centre as well as setting up a network of 45,000 e-mail account holders and a digital library of more than 1,000 journals. The AVU approach uses a careful combination of synchronous video broadcasting, asynchronous sessions, online materials, prepackaged learning materials on CD-ROMs and DVD as well as synchronous chat sessions.

Here, interaction between the learner and the lecturer is primarily by e-mail and online chats during synchronous lecture sessions. Students also have access to online chat sessions and discussion forums with their teaching assistants. The learning centers are supervised by trained facilitators and these are individuals who are familiar with the subject matter being taught and are mature enough to assist students during synchronous and asynchronous sessions. However, the facilitators are always in close consultation with the lecturer and teaching assistant teams.

Indeed, ICTS are one of the most pervasive technologies in the world, second only to 'human intelligence' or the human brain. They are superseded by the human brain only in one sense: in terms of intelligence or creativity. This may be removed if the field of artificial intelligence develops fully. The specialty of human information processing is being tripled by innovations in relation to automatic visual-scanning, voice keys and speech recognition. If it is assumed that wide diffusion of ICTS will occur and that African countries will process extensive and well-functioning higher education sectors, then there is a need to consider what kinds of skills and training will be essential. In other words, there is a need for a range of associated skills and training necessary to outside, diffuse, maintain, and benefit from them. This has implications for managerial and administrative staff in higher education and especially for those responsible for organizing courses and planning curricula, for teaching and research faculty, for the students themselves and for the wider support and maintenance staff. Again various forms of inter-university linkages generally are needed to the utilization of centralized databases and international networking; and this generates a need for a whole range of systems management skills and training. Whatever balance is selected, the functions and modes of teaching and learning need to be considered. Figure 5.1 suggest that there are basically five functions or modes of using ICT resources. Each of these is associated with its own skills and training requirements. Here, the relationship between the function and mode of ICT use depends on the sophistication of the equipment used. In the support mode, technology can be used to increase accuracy and enhance presentation of work, while in the exploration and control mode, the student is able to explore, examine, experiment with and build situations. In the tutorial mode, information is presented at an appropriate level, paved with feedback while in the resource mode; ICTS can be used to access information and other resources. The link mode is present when ICTS are used for communication between individuals such as the use of electronic mails, video-conferencing and webinars. Consequently, an overall systems requirement for restructuring the formal education system in African countries to take advantage of ICTS is the setting up of appropriate coordinating bodies and training for those with responsibility for developing and implementing new strategies. This requires that people develop the managerial, strategic and wide

analytic skills encompassing a national and international dimension and that there is public and private sector input.

However, lifelong learning means that people must be able to move into and out of formal education institutions at different stages of their working lives. Thus, new forms of certificate and accreditation that are not based on hierarchies among institutions of education will be necessary. Here, new systems that are responsive to the needs of each African country will need to be setup. If people are to benefit from the opportunities created by ICTS to enable greater empowerment and new forms of participation in civil society, the organization of governance systems will need to become an issue for governments. Similarly, the NGOs and private organizations will play an increasing role in helping citizens and businesses to extend their capabilities for participating in 'knowledge societies by contributing to the build up of new knowledge networks. Indeed, the annual African e-learning conference is a good starting point. And yet, the major goal of any initiative to implement ICT applications in African countries is to help to alleviate poverty and to ensure that the applications are perceived by their users as being useful.

FIGURE 5.1 SKILLS/TRAINING MODES

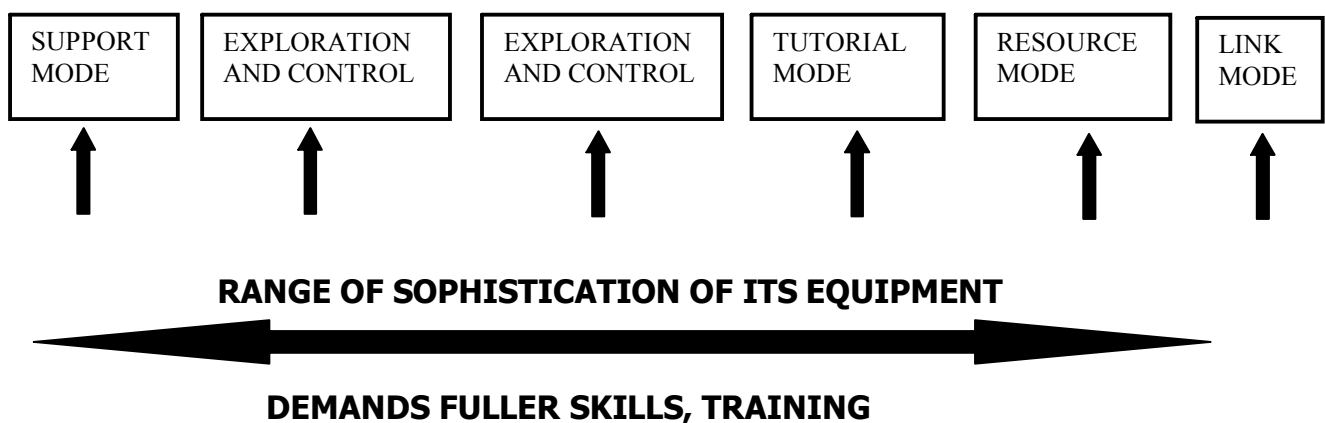

If these goals are not achieved, there is little point in investing enormous amounts of money in the infrastructure for innovative 'knowledge societies in African countries. In these countries, the challenge to invest extremely scarce financial resources in ICTS and in people's capabilities to use them is enormous because of strong competing claims on those resources. However, the promise of ICTS to assist in ameliorating pressing development problems means that efforts need to be made to give priority to strategic investment expenditures. Hence the need for functional policy reform measures in Africa.

Energy policies have a key role in the development and growth strategies of governments. Ready access to reliable, reasonably priced energy is an important catalyst for growth. Unless energy can be produced and delivered more cheaply, it will stay beyond the reach of many of the poor in Africa. For energy delivered through networks; the costs that matter are not only the unit energy costs, but the costs of extending the network in to an urban slum or to a rural town. Extending a network can be very expensive, which is a major barrier to access for poor households and small or isolated communities. Therefore, a control goal of the reform of electricity and gas networks, now occurring in an increasing number of developed and developing countries, is to provide incentives to reduce the costs of producing energy and getting it to consumers. Thus, new technologies in electricity are drastically reducing costs but transmission costs are still a major handle to expanding networks in isolated or lightly populated areas. As a result, it is the urban poor who stand the greatest chance of benefiting from network reform and for the rural poor, attentive solutions are required.

For the foreseeable future, the prospects of better energy services for many of the poor will depend not on the wholesale expansion of electricity and gas networks, but on finding better, cheaper off-grid energy sources. In rural areas and city slums, ways must be found to bring down the costs of cleaners, more reliable fuels and the costs of doing business in supplying and serving poor communities

Poor communities and households need help in making informed choices between energy services and may have to take collective action to secure them. Financing hurdles for consumers on the margins of the cash economy must also be overcome. Both technological and commercial innovation is needed to bring down the costs of producing energy and of financing and managing services. While there are many promising developments, the costs of implementing innovative off-grid projects remain high and the challenges of scaling up are daunting.

In this context, two government roles are likely to be critical; reforms are needed not only in energy networks but in the broader energy markets on which many of the poor rely; and the uses of subsidies must be improved in ways that encourage innovation. Thus, the key drivers for an improved access to off-grid electricity service can shift the emphasis from a centralized toward a decentralized approach. Successful off-grid energy projects must understand and address at the local level, the nature of the demand and its interaction with the local energy source; local operating organization; all possible project development actors; other market agents such as local vendors and electricians; and other energy suppliers off-grid therefore means an expanded role for users a diversity of organizational models, a greater knowledge of both the energy supply in the broadest sense and the energy demand at the site. Here, planner's facilitators and financiers shall all benefit from direct exposure to Local Conditions and the nature of the problem and possible solutions are best defined at the site.

Consequently, the first priority of energy policies aimed at alleviating poverty must be to bring down the costs of safe, clean, reliable energy services. Although, there are some promising trends in that direction, but low-income households must clear

another high hurdle before they become energy consumers and that is the initial cost. They must pay to have gas or electricity connected, or buy a photovoltaic cell or LPG cylinder, and then buy the appliances that will run on the energy. Thus, subsidies are likely to remain a key part of pro-poor energy policies in African countries for some time. Traditional ways of delivering subsidies, particularly cross-subsidization of consumption, often fail to help the poor. They are also less sustainable and make little sense once governments begin liberalizing energy markets. Consequently, the challenge for governments is to find better ways of delivering subsidies by going back to basics on the questions of whom to subsidize, which aspects of cost to subsidize and by how much, and how to deliver these subsidies. Thus, a "good" subsidizing scheme is one that enhances access for the poor while sustaining incentives for efficient delivery and consumption. The subsidizing scheme must also be practicable within the financial and human resource constraints of the government.

The fight against corruption should assume a key place in development policy as a way of strengthening economic growth and helping civil society and democracy to function. Corruption not only stifles growth but also perpetuates or deepens inequality, as the few amass power and wealth at the expense of the many. This is a result both of its traditional institutional arrangements (dominated by state monopolies controlling oil, gas, or electricity) and of the sheer amount of cash it can generate. In fact, corruption in energy takes much form such as petty corruption in meter reading and billing to grand corruption in the allocation of lucrative monopolies. These practices differ in scale but contribute to the same results: weak operational and financial performance, and declining service quality or reduced chances of ever accessing network services. Therefore, the solution to corruption is continuing reform to reduce the incentive and potential to capture monopoly rents and to increase the transparency of public and private transactions, regulatory structures and decision-making processes.

The dominant telecommunications entity, whether government owned or private, should be authorized to do business, raise capital, and plan future operations with as little internal interference as possible and practicable from either the policymakers or the regulatory bodies. In turn, the authority of the regulatory bodies to interfere with operations should be limited to the minimum necessary to ensure that broad goals of national telecommunications policy are carried out, that service meets established standards, and that prices charged do not exceed reasonable levels. These bodies should also have the authority to obtain the information from the telecommunications entities necessary to meet these obligations. The greater the degree of autonomy and commercial orientation of the telecommunication entity, and the greater the role of competitive operators and suppliers, the more need there will be for explicit independent regulatory mechanisms to reconcile private interests with social and national needs. In other words, government needs a way of ensuring that minimum political, social and national concerns are met without it having to involve in day-to-day management of telecommunications activities. At the same time, telecommunications providers need to be sure that political pressures will not continually intrude in business decisions. As the institutional gap widens between the marketplace, provider of telecommunications services, and the political

caretakers of national interests, there is corresponding growth in the need for a credible, expert, and independent buffer or intermediary. In the long run, however, a stable environment capable of withstanding shifts in government requires just such a regulatory mechanism. Otherwise, there is the danger that massive shifts in policy will occur with every election or change in the political wind. Consequently; the tolerance of some reasonable regulatory discipline is a fair price to pay for a strong buffer between the operating entities and political pressures.

Again, there is need to develop a global consulting capacity to advise countries on their overall policy and regulatory regimes. This is not an easy task, because specialized economic, legal, financial, banking and regulatory skills as well as operating expertise are required. Unfortunately, persons with the necessary training and experience in these areas are difficult to find and recruit. Here, it may not be easy for any one telecommunication company to succeed in building such a capacity by itself, but with joint ventures and other mechanisms, progress may be possible. Thus, in this period of rapid change and organizational evolution, there is clearly a need to exchange views and experiences much more frequently. Often many of the relevant experiments that have taken place in one country are not known to other nations contemplating similar steps. Appropriate mechanisms for such exchanges need to be established and much of the exchange is kept informal. Consequently, telecommunications policy makers and managers clearly need to visit each others' countries more frequently. In this connection, international organizations like World Bank, international telecommunications union, commonwealth telecommunications organization and center for telecommunications Development can use their good offices to facilitate such exchanges.

Indeed, acquiring knowledge involves a combination of tapping knowledge from abroad and creating knowledge at home. Because no country can create all the knowledge it needs, learning from others is a critical component of a successful strategy for all African countries – yet the precise approach will vary according to a country's situation. To build their knowledge base, these countries should explore all the means available of acquiring knowledge from abroad and creating it locally. They should find new and better ways of producing goods and services through trade as the structure of trade shifts from commodities to increasingly knowledge-intensive products, get access to new proprietary technical knowledge through technology licensing; establish laws and institutions for the protection of intellectual property rights; attract back home talented people who have studied or worked abroad; and promote domestic R and D to make it more responsive to the market. Again, an effective strategy to narrow knowledge gaps must include measures to increase people's capacity to use knowledge. To address these problems, governments should consider the following possibilities; decentralized education to give more power to those with the most information about educational needs and how to meet them (students parents teachers and school and administrator); focus public resources on those who need them most targeting subsidies to the poor; provide support for science and engineering education; and use learning technologies to improve educational quality. The way governments convey information to citizens, especially the poor, is often critical. So are the ways they listen to citizens and what they learn from them. Therefore, the starting point in all these is listening to the

poor. Here, countries should give the poor voice especially through better educational opportunities and better access to telecommunication; learn about the poor from the poor; work through local channels and earn the trust of the poor as well as providing knowledge to the poor in a manner they can use.

Aid agencies should move beyond assistance to ICT components of investment projects. They should help African governments become effective ICT users; build their competence to formulate and manage national ICT strategies and promote ICT diffusion throughout these economies. Aid agencies should take a long-term view of the roles and capabilities of the public and private sectors and help create ability to learn and adapt technology as well as promoting public-private partnership while creating local capacity to strategically manage a national process of ICT diffusion and learning. This would include the development of consultative and diffusion mechanisms for private sector involvement in planning (implementing) ICT projects and such participation is central to building technological capabilities while ensuring commitment to learning and organization change. Furthermore, the AID agencies may advise governments of the strategic implications of ICT for key sectors like education. They should help formulate strategies and policies to diffuse ICT in support of national development and the long-term objective should be to build local capabilities for scanning the global environment as well as developing home grown responses to the technological revolution. They should assist in developing policies and infrastructures that support the diffusion of ICT as well as building links between ICT producers and users. Here, these ICT specific policies (infrastructure) should complement and not replace the fundamentals in macroeconomic stability (Competition).

Also, Aid agencies should assist the public (private) collaboration in the design and implementation of ICT diffusion programs to improve competitiveness of private enterprises. They should improve the capabilities of government as a user of ICT and manager of public information resources. In other words, they may assist in financing public information systems and networks, designing demonstration projects, promoting competitive and transparent public procurement policies for ICT products and services; developing public information sharing policies and planning a national information infrastructure. They should support strategic alliances and recruitment of ICT multinationals. Here, key aims would be to build channels for technology transfer; help ICT producers gain access to export markets and ICT users obtain advanced applications and expose local producers (Users) to international best practices.

Indeed, recent development thinking has been based on the assumption that markets work well enough to ensure development and alleviate poverty. However, the growing understanding of information constraints suggests that markets alone are often inadequate. The societies also require policies and institutions to facilitate the acquisition, adaptation, and dissemination of knowledge and to mitigate information failures, especially as they affect the poor. In fact, this view implies an expanded mandate for public action. And yet, government, like markets is hampered by information failures. In deciding which problems to address, policy makers must balance the size of the information problem and the resulting market failure against

the capacity of the government to improve the situation. Thus, the appropriate course of action will vary depending on the circumstance. However, in all the African countries, openness to learning, recognition that there is much we do not know, and a willingness to make midcourse adjustments will enhance prospects of success. Table 6.1 summarize the policymakers matrix for national information infrastructure of a typical African economy (Melody, 1996 and Nwaobi;1999) whatever the policy direction is, it is important to note that climate change is defining human development challenge of the 21st century. Failure to respond to that challenge will stall and then reverse international and national efforts to reduce poverty and ignorance. Consequently, there is great need to provide assistance in reducing vulnerability and building the capacity of African countries to more widely reap the benefits of the clean development mechanism (CDM).

TABLE 6 1 NATIONAL INFORMATION INFRASTRUCTURES PRIORITIES: POLICY MAKERS MATRIX

S/N	A MARKETS ACTIVITIES	B EQUIPMENT SUPPLY	C NETWORK DEVELOPMENT	D CONTENT/VALUE ADDED SERVICES	E DEMAND APPLICATIONS
1	PLAYERS ELETRONICS	TELECOMS COMPUTING MEDIA ELECTRONICS	PULIC TELECOMS OPERATOR OTHERS	NATIONAL REGIONAL GLOBAL	INDUSTRY GOVERNMENT HOUSEHOLDS
2	RESOURCES REQUIREMENTS	TECHNOLOGY CAPITAL SKILLED	CAPITAL SKILLS MANAGEMENT	SKILL MANAGEMENT MARKETING	INTEGRATION SKILLS CAPITAL
3.	POLICY REGULATION	INDUSTRY DEVELOPMENT PURCHASING POLICY IMPORT EXPORT	TELCEOMS REFORM UNIVERSAL SOURCE SPECTRUM MANAGEMENT PRIVACY SECURITY	ACCESS INTELLECTUAL PROPERTY STANDARD	SECTORAL REFORM SKILL CHANGES TRANSITION POLICIES
4.	PRODUCTS SERVICES	TRANSMISSION TERMINALS SOFTWARE	PUBLIC SERVICES DESIGNER NETWORKS LEASED CAPACITY	DATABASES VALUE ADDED SERVICES MEDIA	DESIGNER NETWORKS SPECIALIZED CONTENT NETWORK MANAGEMENT
5	STRENGTHS WEAKNESSES OPPORTUNITIES THREATS	BY PRODUCT LINE BY TECHNOLOGY DEVELOPMENT BY SKILLS BASE	NETWORK COVERAGE NEW SERVICE DEPLOYMENT PRODUCTIVITY IMPACT	LOCAL CONTENT ACCESS SKILLS	LENDING AND LAGGING SECTORS COMMITMENT TO REFORM RELEVANCE OF SERVICES, TO NEEDS

7.0 CONCLUSIONS

Development and operation of energy (power) efficiency investment delivery mechanisms is an institutional development issue, and energy (power) efficiency financing programs and projects must recognize this clearly. Thus, this requires a major effort to ensure that the planned institutional solutions match the institutional environment in which they are expected to function. Furthermore, new institutional mechanisms cannot be expected to develop and grow overnight and therefore sustained efforts are required. In most cases, steady and strategic government support is a very important enabling factor for the type of institutional development required to truly improve delivery of energy (power) efficiency financing.

Consequently, capacity development is the key to sustainable human development. Without an enabling environment, efficient organizations and a dynamic human resource base, countries lack the foundation to plan, implement and review their national and local development strategies and promote human development. In other words, it is impossible to work on policies without at the same time working on the capacities of people, organizations and the larger community. Basically, it is institutions that sustain policies, allowing policies to evolve from words into actions governing the development process. The development of the institution (at the grassroots level, at the community level, and at the national level) is at the centre of the development challenge. Here, this challenge could be about its resource base, systems, or environment in which it must function. Thus, there is need to place priority on strategies that create opportunities to develop and sustain capacity at national and local levels. There include institutional reform and incentives; scaling up leadership capacities; promoting education, training and learning; and enhancing accountability and broad engagement on achieving development results. Above all, capacity development should be about transformations (in people, organizations and societies) that lead to sustainable human development

Therefore, ICT initiatives must be linked to development goals in a way that leads to action and widespread social and economic benefits if they are to be successful. This requires substantial coordination, organizational change, and new partnerships. It is especially difficult for the African countries, given their lack of financial resources and adequately trained personal, to devise and implement ICT strategies. Yet, the task of building national information infrastructure involves both people and technologies. It involves creative approaches to reconfiguring financial and human resources. There, the institutional setup is crucial to whether new initiatives are successful and the learning process is an ongoing one. Again, not all development

problems can be addressed simultaneously in the face of competing claims on very scarce resources. Nevertheless, African countries which take some action on both the technological and human resource fronts will be better positioned to benefit from ICT applications and to reduce the impact of exclusion from emergent 'knowledge societies. African initiatives are likely to be successful if they avoid promotion of ICTs as a panacea for complex social and economic problems. If the satisfaction of fundamental human needs is the 'driver' of the introduction of ICTs, there is a greater chance of success than if, the technology is permitted to 'drive' applications. Thus, the design of the implementation of ICTs should seek a 'good fit' between the technology and culture of the recipient country.

However, there is a risk that the diffusion of ICTs and the transition to knowledge - based development will exacerbate existing social and economic problems. The creation of new jobs could be counterbalanced by the loss of jobs in traditional sectors. The social and cultural infrastructure which enables a positive working environment and community based activities may not support the new requirements of knowledge societies. Instead of being empowered by ICTs, disadvantaged or excluded groups (including women, unskilled) and disabled) may be further marginalized.

Furthermore, labor unions around the world representing unionized workers in the ICT sector are recognizing that many traditional jobs, especially in the installation and maintenance of telecommunication networks, will be eliminated as advanced technologies are introduced and markets are opened to competition. However, it is also expected that new jobs will be created in the design and provision of network services and multimedia products. Thus, there is a growing need for detailed employment studies so that the staffing impact of new ICTs can be understood and plans for re-education, retraining, and re-skilling can be put in place. On the other hand, investment in a highly skilled labor force is helping to create new employment opportunities in some of the African countries. Yet, it is unclear whether people who are already socially or economically excluded from the workforce are benefiting from ICTs. In the absence of systematic empirical data, little can be said about the costs of transition to economies in which knowledge based production is increasingly central. For those without opportunities for skills upgrading, changes in employment patterns lead to a greater risk of exclusion from the workforce.

Thus, as African countries assess their strengths and weaknesses in the light of the Job creation potential of ICTs, the condition of employment and the capacity of the social infrastructure to support the new workers, need to be considered. On the one hand, information-related service jobs are associated with the dislocation of family and community life and threats to the health of workers especially for women. On the other hand, new types of employment and modes of work organization can be highly beneficial leading to improved quality of life and greater economic resources. Here, the relationship between investment in education and training, and the kinds of jobs that will need to be done in knowledge based societies, must be fully understood. Again, the initiatives to generate empirical information on changing patterns of employment, training requirements, and the quality of work environment, could be launched by international agencies and the private sector in cooperation with national governments.

The increased tradability of services will depend on whether continuing innovation in ICTs enables more knowledge to be codified in digital formats. However, tacit knowledge which enables people to produce or use information creatively, will remain an essential issue as efforts are made to harness ICTs to development. Assembling the 'tools' is only part of the task facing African countries as they design new or improved national ICT strategies. Measurers must be taken to assemble the human capabilities and related technologies to make the best use of the new opportunities offered by ICT. This assembly process will be market-led in many instances, but to achieve certain social objectives and to reduce the extent of exclusion, public initiatives will also be needed. Indeed, there is hope for African modern economies to exist in the new world order of the 21st century.

REFERENCES

- Acemoglu, Daw S. Johnson (2005) "Unbundling Institutions", Journal of Political Economy, 113(5): 949 – 995
- An tonelli, C. (ed.) (1992) The Economics of Information Networks, Amsterdam: North Holland
- Ayodele, A. S. (1987) Energy Development and Utilization in Nigeria, Ibadan: Niser
- Beenstock, M (1991) "Generators and the Cost of Electricity Outages", Energy Economics 13 (3)
- Central Bank (2006) Annual Report and Statement of Accounts, Abuja: Central Bank of Nigeria
- David, P. A. and J. Bun (1988) "The Evolution of Gateway Technologies and Network Evolution: Lessons from Electricity Supply History", Information Economics and Policy, No 3 pp 165 – 202
- Dutton, W. H. (1997) Information and Communication Technologies Visions and Realities, Oxford University Press
- ECOWAS (2006) ECOWAS Annual Report, Abuja: ECOWAS
- ECOWAS (2007) ECOWAS ANNUAL REPORT, ABUJA: ECOWAS
- Eliasson, G. (1990) The Knowledge-based Information Economy, Stockholm: Almquist & Wiksell International
- Elsevier (1996) Yearbook of World Electronics Data, Amsterdam: Elsevier
- Foray, Dand M. Gibbons (1996) "The Knowledge-based Economy: from the Economics of Knowledge to the Learning Economy in OECD (ed) Employment and Growth in the Knowledge-based Economy, Paris: OECD
- Freeman, C. (1994) "The Economics of Technical change", Cambridge Journal of Economics, Vol. 18 (5) pp 463 – 514

- Griffin, J. and H. B. Steel (1980) Energy Economics and Policy, New York: Academic Press
- Hancock, A. (1997) 'Hidden Treasure' in Cliché, D. (ed.) Cultural Ecology: The Changing Dynamics of Communications, London: International Institute of Communication
- Hanna, N. et. Al. (1995) "The Diffusion of Information Technology Experience of Industrial Countries and Lessons for Developing Countries", World Bank Discussion Papers, 281
- Hicks, D. M. and Katz, J. S. (1996) "Where is Science Going?", Science, Technology and Human Values, Vol. 21(4) pp 379 – 406
- Hirst, P. and G. Thompson (1996) Globalization in Question, Cambridge: Polity Press
- ITU (1995) Telecommunication Indicators for the least Developed Nations
Geneva: International Telecommunications Union (ITU)
- Iwayemi, A. (1994) Deregulating Public Utilities: An Analysis of Electricity Industry in Nigeria", Energy Policy, Jan.
- Kalu, B and Wilson, E. J. (1997) National Information Infrastructure 111 Initiatives: Vision and Policy Design, Cambridge: MIT Press
- Komives, K et.al. (2005) Water, Electricity and the Poor: Who benefits from Utility Subsidies? Washington: World Bank
- Kosmo, M. (1989) "Commercial Energy Subsidies in Developing Countries: Opportunities for Reform", Energy Policy, June, PP 244 – 253
- Kuznets, S. (1973) "Modern Economic Growth: Findings and Reflections", American Economic Review, Vol. 63 PP 247 – 258
- La Porta et.al. (1999) "The Quality of Government", Journal of Law, Economics and Organization 15(1): 22 – 279
- Lundvall, B. A. (1996) The Social Dimension of the Learning Economy, DRUID Working Paper No 1
- Mansell, R. and U. Wehn (1998) Knowledge Societies: Information Technology for Sustainable Development, Oxford: Oxford University Press
- Melody, W. H. (1996) "Toward a Framework for designing Information Society Policies", Telecommunications Policy, Vol 20 (4), PP 243 – 259

- Mills, E. (2003) "Risk Transfer via Energy-savings Insurance", Energy Policy 31: 273 – 281
- Mody, A and C. Dahlman (1992) 'Performance and Potential of Information Technology: An International Perspective', World Development, Vol 20(12) PP 1703 – 1719
- Mungisinghe, M. and M. Gellerson (1988) "Reliability of Electricity Supply, Outage Costs and value of Service" Energy Journal, Vol 9: 1 – 8
- Munaisinghe, M. (1990) Electric Power Economics, London: Butterworths
- NBS (2000) National bureau of Statistics (NBS) Annual Abstract of Statistics, Abuja NBS
- Nwankiti, O. C. (1981) Man and his Environment, Lagos: Longman
- Nwaobi, G. C. (1999) "Information Technology in Africa: Structure and Diffusion" Proceedings of the 12th World Congress of International Economic Association, Beunes Aires, Argentina.
- Nwaobi, G. C. (2000) The Knowledge Economics: Trends and Perspectives, Lagos: Quanterb/Goan Communication Press
- OECD (1992) Technology and the Economy: The key Relationships, Paris: OECD
- Pritchett, L. (1996) 'Forget Convergence: Divergence Past, Present and Future', Finance and Development, June, PP 40 – 43
- Rai, G. D. (2006) Non – conventional Energy Sources, Delhi: Khana Publishers
- Roa, S. and B. B. Parulekar (2007) Energy Technology: Non-conventional, Renewable and Conventional, Delhi: Khanna Publishers
- Sanders, R. J. et.al (1994) Telecommunications and Economic Development, Washington World Bank
- Schuler, D. (1996) New Community Networks: Wired for change, New York: Addison – Wesley
- Schwaller, A and A. Gilberti (1996) Energy Technologies: Sources of Power, New York: Glencou/McGraw – Hill
- SOETE, L. (1985) 'International Diffusion of Technology, Industrial Development and technological Leap Froging', World Development, Vol 13(3) PP 409 – 422

- Taylor, R. P. et.al (2008) Financing Energy Efficiency: Lessons from Brazil, China, India and Beyond, Washington: World Bank
- Tiffin, J. and R. Rajasingham (1995) In search of the Virtual Classroom: Education in an Information Society, London: Routledge
- Theraja, B. L. and A. K. Theraja (2008) A Textbook of Electrical Technology, New Delhi: SCHAND COMPANY
- Ukong, I. I. (1973) "The Economic Consequences of Electric Power Failures", Nigerian Journal of Economic and Social Studies, Vol. 15(1)
- United Nations (2007) United Nations Human Development Report, New York: United Nations
- United Nations (2008) United Nations Development Programme Annual Report, New York: United Nations
- Wellen, B. et al (1989) Restructuring and Managing the Telecommunications Sector Washington: World Bank
- Wellenius, B. (1993) Developing the Electronics Industry, Washington: World Bank
- Wilson, R. (1989) "Efficient and Competitive Rationing", Econometrica, Vol 57 No 1
- Womark, J. J. D. and Rons, D (1990) The Machine that changed the world, New York: Rawson Associates
- World Bank (1993) Nigeria: Issues and options in the Energy Sector [ESMAP 11672 – UNI] Washington: World Bank
- World Bank (1998) World Development Report, Washington: World Bank
- World Bank (2000) Energy and Development Report, Washington: World Bank
- World Bank (2002) World Development Report, Washington: World Bank
- World Bank (2003) World Development Indicators, Washington: World Bank
- World Bank (2004) World Development Report, Washington: World Bank
- World Bank (2007) African Development Indicators, Washington: World Bank