

orbit calculations have been performed, and on the basis of these a detector system and its housing have been designed. There will be a parallel plate avalanche counter with position wires in both the bend and the non-bend plane, a proportional counter, and an array of silicon microstrip detectors. A diagram of the system is shown in Fig. 3. At the present time, the avalanche counter has been designed and an order has been placed for the silicon. It is expected that the entire system will be assembled and tested by the end of calendar year 1990.

1. H.O. Meyer, P. Schwandt, W.W. Jacobs, and J.R. Hall, *Phys. Rev. C* **27**, 459 (1983).
2. J. Homolka, W. Schott, W. Wagner, W. Wilhelm, R.D. Bent, M. Fatyga, R.E. Pollock, M. Saber, R.E. Segel, P. Kienle, and K.E. Rehm, *Nucl. Inst. Meth. A* **260**, 418 (1987).
3. Indiana University Cyclotron Group, *The IUCF Cooler-Tripler Proposal to the NSF*, Indiana University (1980).

PIONIC ATOMS AS COMPOUND STATES IN NUCLEON-NUCLEUS COLLISIONS: STATUS REPORT ON THE COOLER EXPERIMENT CE02

H.O. Meyer, L. Bland, G. Emery, M.G. Minty, H. Nann, P.V. Pancella, S. Pate,
R. Pollock, B.v. Przewoski, T. Rinckel, P. Schwandt, and F. Sperisen
Indiana University Cyclotron Facility, Bloomington, Indiana 47405

1. Introduction

The formation of pionic atoms in nuclear collisions just below the π^- production threshold has been postulated some time ago.¹ Attempts to observe this process have so far not met with success. The goal of experiment CE02 is to measure a cross section excitation function for $p+^{13}\text{C}$ elastic scattering, and to look for a resonance near the π^- production threshold.

An update of the original proposal of 1984 was presented during PAC XXIX in December, 1989. In the light of our present understanding of the Cooler performance, the experiment still seems to be feasible, although the demands on energy resolution and luminosity are substantial. It was concluded that in order to find and map out the resonance (corresponding to a pionic ^{14}O in the 1s state) with 4 keV energy resolution, 25 shifts of beam time should be sufficient. This does not include beam time for the development of the appropriate experimental conditions.

The apparatus for the detection of the scattered protons will be taken over from the CE01 experiment (see elsewhere in this annual report). Since backward angles are of interest, the CE01 detector arrangement will be reversed. In addition, in order to more clearly define the experimental signature, a detector for the recoiling target nuclei will be mounted in the forward direction. Tests with heavy ion beams from the Notre

Dame tandem accelerator have convinced us that a parallel-plate avalanche detector is a suitable detector for this purpose. Such a detector which fits the experimental constraints is presently under construction. Both the tests and the detector design are described below.

The energy resolution and the luminosity which can be achieved with the Cooler will be investigated in the near future. Fiber targets will initially be used, but the use of the recently developed microparticle target (see elsewhere in this annual report) might be considered at some stage. After the feasibility of the planned measurement has been demonstrated, the apparatus in the G-section of the Cooler will be modified, and the experiment will be ready to run in early 1991.

2. Parallel-plate avalanche detector for recoil nuclei

a) Tests at the Notre Dame tandem accelerator

Using the tandem accelerator at Notre Dame University in December, 1989, we tested a parallel-plate avalanche detector (PPAD) in order to determine its suitability for use in CE02. We first proved that the PPAD was indeed sensitive to heavy ions, in particular to carbon nuclei. We then studied the PPAD response and determined that the output pulse height depends linearly on the energy deposited in the detector. Finally, we studied the relative energy resolution of the PPAD in order to be able to ascertain whether or not we could resolve carbon-induced signals from those of lighter ions. The detector efficiency, output pulse height, and energy resolution were all measured as a function of the PPAD operating pressure and applied voltage.

The tested PPAD was a prototype of one octant of an annular PPAD intended for use in CE02 and is depicted in Figure 1. The electrode spacing was fixed at 3.6 mm and the detector capacitance was about 20 pF. Isobutane was used as the chamber gas. Heavy ions from the Notre Dame Tandem Accelerator were scattered from a target. At a right angle to the incident beam direction an extra chamber was added containing the PPAD. Delta ray electrons of approximately 10 keV were suppressed by SmCo magnets. A slit assembly served to define the 0.7 msr solid angle. A 450 mm², 500 μm thick silicon detector was positioned behind the PPAD.

We used beams of ⁷Li, ¹¹B, and ¹²C ions. With each type of projectile data were taken with two different targets: a gold foil in the transmission geometry for producing monochromatically scattered beams, and a thick tantalum layer in reflection yielding a continuous energy spectrum. Beam energies were selected between 30 and 50 MeV. The PPAD was operated at three different pressures (4, 7, and 10 Torr) and the voltage was varied at each pressure. We measured the output pulse heights of both the PPAD and the silicon detector as well as the time of flight between the two detectors.

The efficiency of the PPAD was measured by taking the ratio of the number of events recorded by the PPAD to the number detected by the silicon detector. As the voltage applied to the PPAD is increased, a well defined threshold is reached beyond which the measured efficiency is larger than 99.5%. The threshold depends on particle type and energy. At 7 Torr, all three incident ion types were detected with 100% efficiency over the relatively wide range of 630 to 680 Volts. The operating voltage is limited by the electric breakdown threshold of the detector.

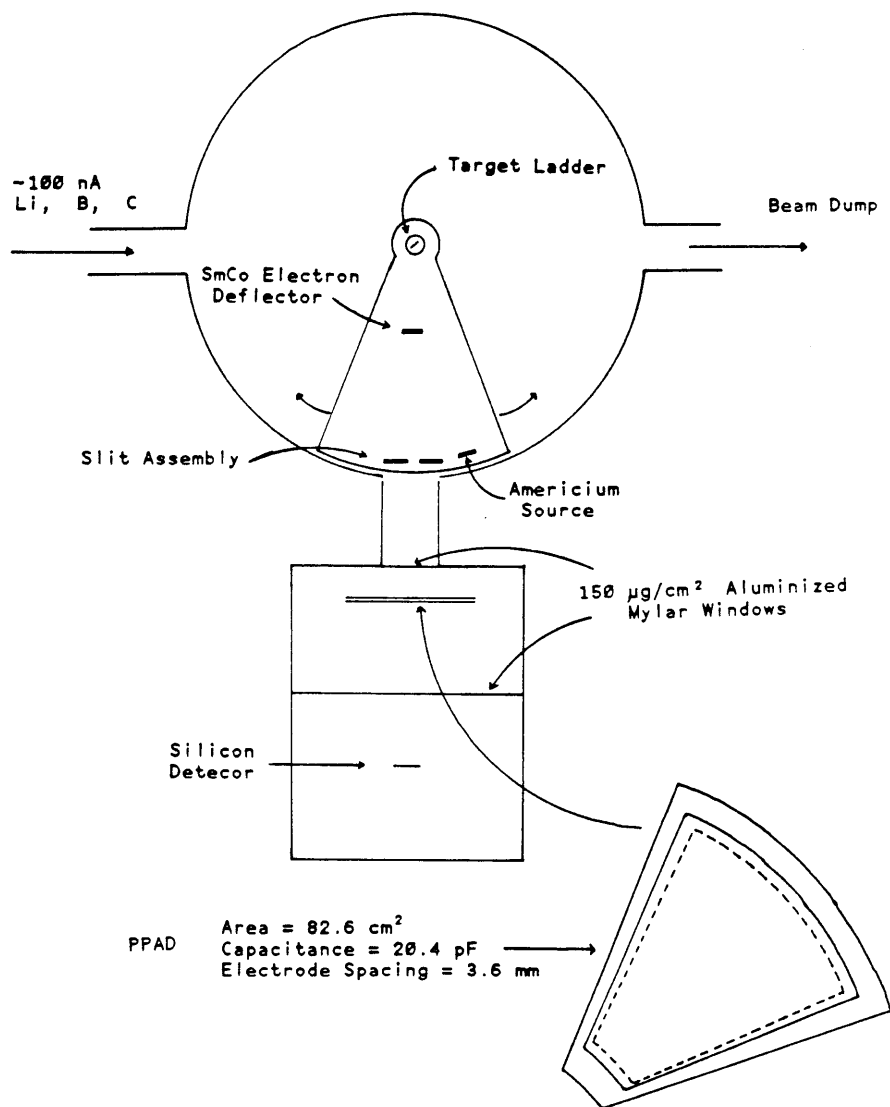

Figure 1. Experimental geometry for a recoil detector test at the Notre Dame University Tandem Laboratory.

The PPAD was energy calibrated using the measured energy in the silicon detector to calculate the energy deposited in the PPAD using known values for the ranges and the energy losses of the heavy ions in traversing the various media. At fixed pressure and voltage the relationship between PPAD output pulse height and energy deposition proved to be linear over the energy and pressure ranges of interest.

The energy resolution, defined as the ratio of the measured full width at half maximum of the peak in the PPAD energy spectrum to the PPAD output pulse height, was measured in two ways by using either monochromatic or continuous energy beams. Plotted in Figure 2 is the PPAD energy resolution as a function of operating pressure obtained from irradiating the detector with monochromatic carbon particles. At each pressure the resolution is measured as a function of the applied field. Shown are the values of the mea-

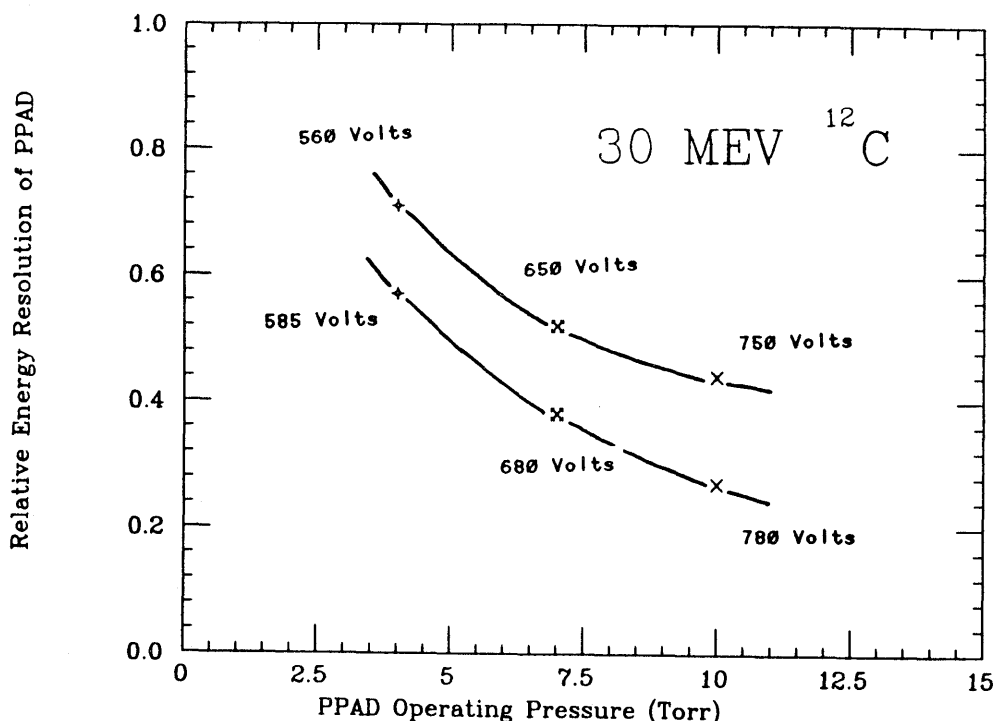

Figure 2. Energy resolution of the parallel-plate avalanche detector.

sured resolution corresponding to the two highest voltages at which data were obtained prior to electric breakdown of the detector. The curves serve to guide the eye. The other scheme utilized the continuum of incident particle energies produced by scattering in reflection from a thick target. By sorting the data according to the energy in the silicon detector, the PPAD resolution as a function of projectile energy was deduced. In Figure 3 the gated PPAD spectrum corresponding to the highest-energy scattered particles (hence those depositing the least energy in the PPAD) is shown. Again, the best resolution was obtained for the largest energy depositions into the PPAD.

In conclusion, the PPAD detected carbon nuclei in the energy range of interest for CE02 with 100% efficiency over a wide range of pressures and applied voltages. We learned that the measured output pulse heights of the PPAD depend linearly on the energies deposited in the detector. We also found that the intrinsic resolution is optimized for the largest energy deposition in the PPAD. Furthermore, it is clear that the resolution improves with increased detector gain; that is, at fixed pressure the resolution is optimized for the highest applied field. Based on the measured energy resolution of the PPAD as a function of pressure and voltage, we may now investigate the question of the mass separation attainable with the PPAD. Superimposed in Figure 4 are the raw two-dimensional energy loss spectra obtained by scattering both lithium and carbon off of the thick target. The data show clearly that the carbon nuclei may be resolved from lithium, one of the most likely spallation products we expect to encounter in CE02. Based on the results we also expect that the mass resolution can be improved by operating the PPAD at higher pressures.

We would like to thank J. Goerres, E. Berners, and S. Darden of the Physics Department at the University of Notre Dame for their assistance during the experiment.

Figure 3. Gated parallel-plate avalanche detector energy spectrum.

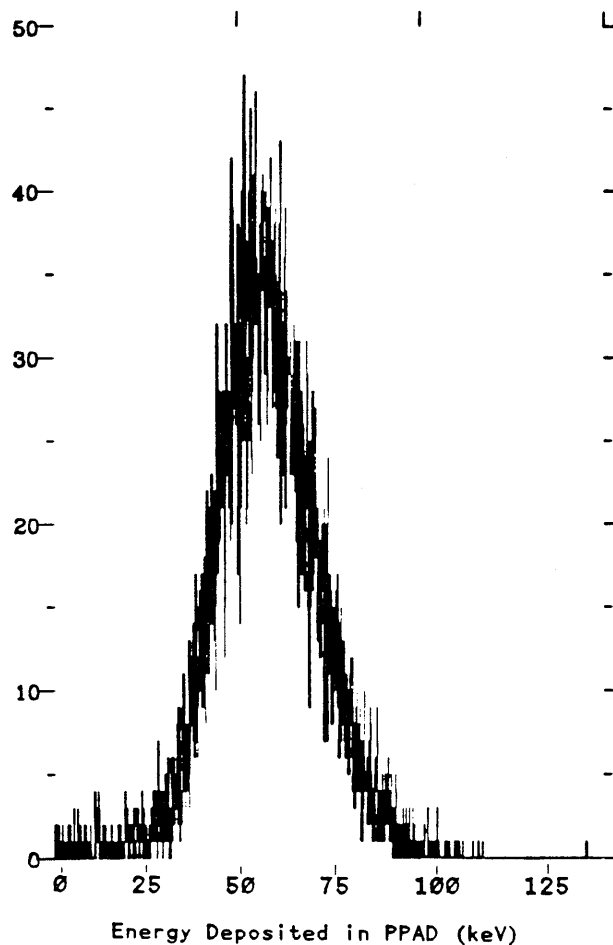

b) Design of a recoil detector for use in the Cooler

The technical design of the detector was based on the results of the test run at Notre Dame. The main goal of the design was to subtend a solid angle as large as possible for recoil nuclei which are in coincidence with protons that reach the CE01 detector. Mounted at a distance of 50 cm from target, the sensitive area of the detector covers an angular range of 4.5° - 15.5° which corresponds to 146° - 170° for the backscattered protons. The angular range chosen overlaps with an angular range where a measurement of the elastic cross section already exists (up to 160°) and the angular range where the resonance is expected to be discernible from nonresonant background (150° - 180°). In order to obtain some information on the position of the recoil carbon nuclei, the eight fold geometry of the CE01 detector array was copied.

1. G.T. Emery, Phys. Lett. **60B** (1976) 351.

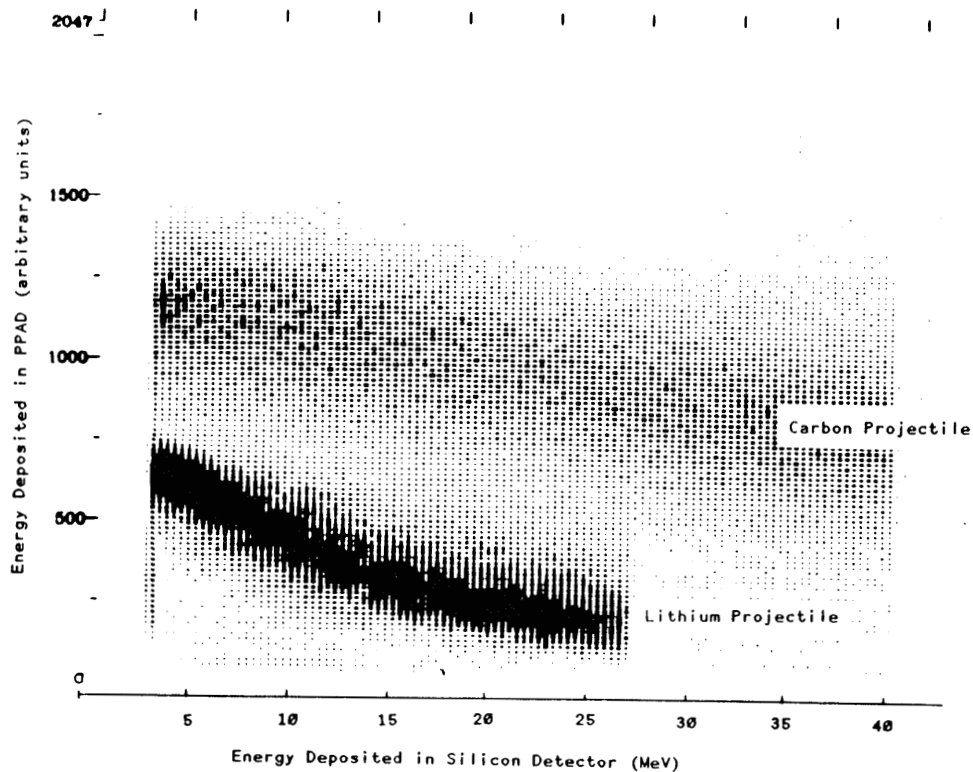

Figure 4. Raw, two-dimensional energy loss spectra.

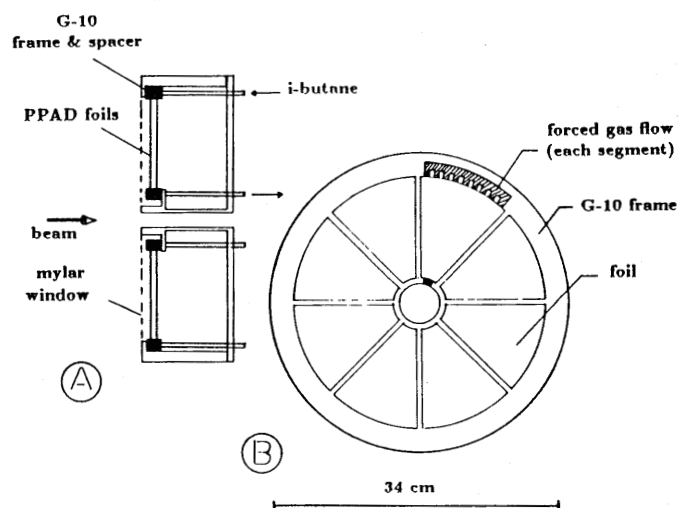

Figure 5. A) Side view (schematic) of the CE02 detector. The entrance window and the PPAD planes are made from 0.15 mil thick aluminized mylar. The PPAD foils are prestretched to achieve a uniform field and epoxied onto 1.6 mm thick G-10 frames spaced by 3.2 mm. The voltage between the planes is 800 V. Iso-butane is used as counting gas at a pressure of 20 T. B) Front view of one of the sensitive planes. The clearance for the beam is 3.5 cm diameter. For one segment the channels for forced gas flow are indicated. As indicated in A the gas inlet is at the outer radius of the detector.