

hypercreature | rhizome

... *A Performative Work*

RAYA MASSIE

The word [figures] is to be understood, not in its rhetorical sense, but rather in its gymnastic or choreographic acceptation; in short, in the Greek meaning: *σχῆμα* is not the ‘schema,’ but, in a much livelier way, the body’s *gesture* caught in action and not contemplated in repose: the body of athletes, orators, statues: what in the straining body can be immobilized.

Roland Barthes, *A Lover’s Discourse: Fragments*

— WRITING

This writing is an experiment, created primarily out of a synergy of *rhizome*, *flesh*, *concept* and *hypercreature*, although there are also infinite others resonating through the work. This writing is not, however, a ‘rhizomic’ or ‘fleshy’ work: it is neither faithful, nor does it seek to represent; it is not a rhizomic performance, but rather the writing is performative of hypercreature, rhizome and flesh. It is not a duplicity, but a multiplicity: this writing is an evolution or perhaps a ‘creative involution’ of these concepts. Thus it is not the logic of other writers that I would (impossibly) seek to ‘reveal’, but rather a deterritorialisation that would exceed and go beyond; a creative reinvention of their words and their work. At times, however, this writing uses the very words that they do, although I have recontextualised them in terms of the hypercreature. It is not a respectful homage to their work, but rather a nomadic wandering into and through their writing. This writing tries to wander through the rhythms and the poetics of their work, the sensual and affective spaces of their thinking. If it is a homage of sorts, then it is a homage to the erotics of pedagogy that I have found in reading

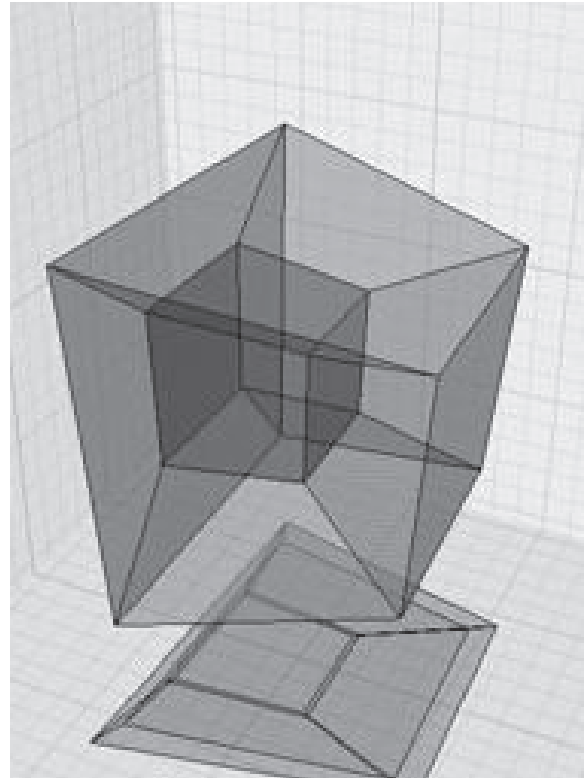
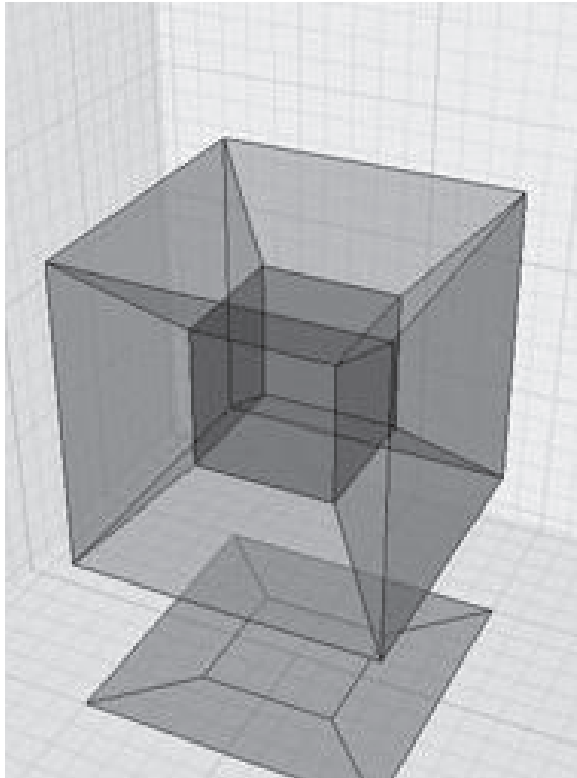

their work. The writing emerged as a way of wanting to immerse myself—my body—into the space of their work, to feel their writing up against my own. It is perhaps a sensuous scholarship that attempts not so much ‘to inform’, but ‘to arouse’ thinking. I want these affects to *feel*, and be felt, in the flesh of the reader.

In this performance my flesh is not his *flesh*, even if it once was. It came from him—came, in the ecstasy of his influence—but it is no longer his human intention. My flesh unfolds the non-human as well as the inhuman, as well as the discursive regimes by which bodies are (de)composed. Their concepts of *rhizome* and *concept* unfold in my writing as *hypercreature*, and his *intercorporeality* and the general terms ‘corporeality’ and ‘the body’ lose a substantial materialism.

In the mobile, shifting, morphic space of writing, our work becomes thought itself through the creative process when the materials we work with, as we work them, do the thinking for us. The events of creating a work are the intelligence of thinking: this writing, rather than myself, is intelligent space, and is a space that is invested with multiple voices and multiple histories. These multiplicities emerge in the writing, intentionally or otherwise, and it seems that I cannot stop them from doing so, for it is not up to me: we are not the author of a work that we can call our own, but instead perhaps a writer for writing itself.

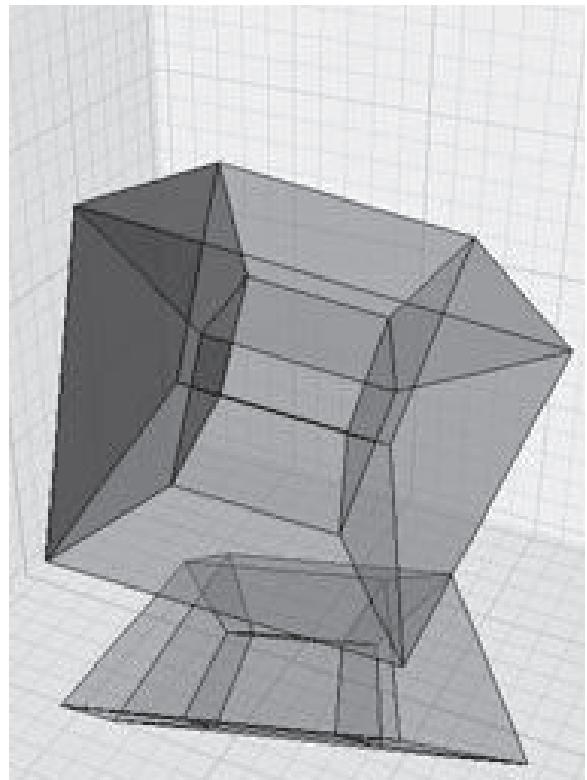
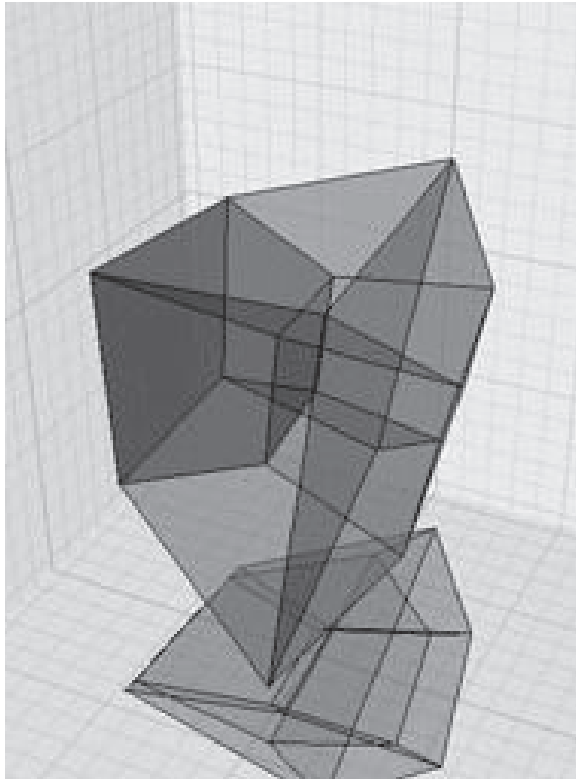

Hypercube series by Drew Olbrich

— HYPERSPACE

'Hyperspace' is a generic term for 'non-Euclidean space', and a 'hypercube' is, by mathematical definition, what appears if we move a cube in four (or more) spatial directions perpendicular to all its edges. What this actually means is irrelevant to my purposes here, except to say that objects in hyperspace—or 'hypercreatures', as I prefer to call them—are somewhat invisible to the three-dimensionally trained eye. A three-dimensional vision maps the observable world into objects that are given a length, width, height and volume, which then defines that object as a particular 'body'. Humans are said to 'naturally' see three-dimensionally, and the 'human attribute' for three-dimensional visual construction is supposedly 'innate'. But is 'nature' so benign? Suffice to say for the moment that, generally speaking, people find hyperspace virtually impossible to visualise, and equally difficult to imagine.

Hypercreatures are impossible to visualise fully and difficult to 'make sense of' as definitive objects, because the surfaces and points of a hypercreature are not fixed, but change—at least from a three-dimensional perspective—in respect to other parts they are being compared with. Objects in a three-dimensional visual field have a more or less definitive outside and inside that in hyperspatial realms is unhinged. The hypercreature defies the polarisation of internal and external as logical opposites.



Line drawing by Edwin Abbott
Abbott, 1885

If I look at a computer generated image of a hypercube and look at one point of its body, and then another, I might begin to see the creation of an object. But when I look to a third and fourth point suddenly that object, and my attempts to ‘construct’ that object in my vision, collapses. I might see, at one moment, an outside surface, but then suddenly that surface is an internal one, strangely suddenly complete and whole. But this ‘internal wholeness’ was a moment ago a seemingly flat external plane. In its state of becoming, the hypercreature seems to have an internality that cannot be excluded from its externality. Or, perhaps it is that I can no longer situate inside and outside as opposites, or even as defining aspects of the creature, in the way I might in a three-dimensional construction.

As I watch this mysterious creature, this spinning hypercube, it revolves and unfolds external and internal planes, cubes and points. These surfaces, cubes and points of the hypercube do not seem to have a ‘where’ (a location) so much as ‘hows’ (processes or performances that create the hypercreature in its becoming). The ‘positions’—and I am using that word with caution now—are not fixed, but perhaps possibilities in relation to something else. The hypercreature asks me, ‘Just what are you trying to define me in terms of: me in relation to this point over here, or me in relation to that point over there?’

The hypercreature is not a static creature, but is unstable and polymorphic. This is to say that if the creature were 'at rest' it would no longer be a hypercreature, but just a line drawing. 'Movement' is not only inherent to the 'body' of the hypercreature: the hypercreature is movement, and it is not a hypercreature without that movement. I will be insistent on this point: the hypercreature is not a 'thing that is moved', but rather is movement that inspires the possibility for thing-ness. The mobile view generated by the computer is, in many ways, not a 'mobile' view at all, but a somewhat 'fixed' image, projecting the hypercreature in its most fundamental 'resting state': a state of unstable or perhaps 'metastable' equilibrium.

The hypercreature is continuously folding and unfolding itself, emerging out of both what it is and what it is not. It folds in on itself, but this same movement is somehow moving out of itself at the same time. The hypercreature is an un/folding performance that appears of, but not necessarily by, itself. Language is failing me here, because how can we describe something that refuses to be clarified, something that refuses the language we use to describe space? So many concepts and much of our language contain concealed imperatives for three-dimensional space. But what do we replace that with? How might we think and speak 'hypercspatially'? When concepts are altered through changing their influences, or the relations through which they are real-ised (that is, made real), how do we shift language so that it allows us to speak differently, to think differently?

Perhaps one of the most interesting aspects of the hypercreature, and the concepts of hyperspace more generally, is that thinking about the possibilities for non-Euclidean spaces challenges us to reconsider the assumptions that are given to 'what is known'. Space is mapped three-dimensionally (as well as given a dimension of time), and yet thinking in hyperspatial terms asks us to reconsider what we might mean by 'space' itself, and 'objects' and 'bodies' that are part of that space. It is taken for granted in three-dimensional space that 'inside' and 'outside' are oppositional, and rarely do we 'seriously' consider the possibility that they might not be: that what is outside a body is not necessarily separate and absolutely 'other' to that body, or that the inside of a body is intertwined and somewhat continuous with its outside. It is perhaps assumed that an object can be given a visual static profile that defines it as a thing in the world, but what happens when we think of bodies that are 'morphologically becoming' bodies: bodies that are 'materially'—(im)materially?—intercorporeal? How might we describe a body that unfolds the world through its flesh? What happens to 'materiality' in a morphological becoming? What happens to the subject and subjectivity? What happens when we renegotiate the possibilities for a body when we remove the assumptions that our gaze comes from an inside and looks upon a world that is mapped as outside our bodies? What happens when we consider the (im)materiality of the body as a dynamic and

performative worldly unfolding? How do we look at the world that is *inside* ourselves? Thinking in terms of hyperspatial gestures asks us to rethink how the world is perceived, to undo the logic of what we thought we always knew.

— HYPERCREATURE

The hypercreature is never itself, never singular, always multiple. Yes, always a crowded space: other components come crashing in, mostly uninvited. Polymorphic and unstable, the hypercreature twists and turns, capturing this, releasing that. Always morphing into something else, someone else, everything outside itself, and turning that outside into itself, and then out again. And then it might seem that it belongs to one, or to another, and just when you think you've got it, just when you think you can hold it down and look it straight in the eye and say 'I can define you thus ...' suddenly it twists again, and what it was it is no longer. Just when you think you can say, 'This is my self, my body', it already isn't. You don't own the thought, the image, the words, any more than they own you. You borrowed them for a little while and made them your own, creating pathways in your flesh to re-member them, but they were never truly yours. Never from just inside you, always inclusive of a without, and unfolding back to that outside as we speak.

Every hypercreature has multiple components and is defined by them: there is no hypercreature with only one component. You and I, in relation, are two components of the hypercreature. From the point of view of the hypercreature, you are neither subject nor object, but several. For you to be other to me the hypercreature must pre-exist our relation, and it's the hypercreature from which both of us must emerge. Any component within the hypercreature can be connected to any other, and must be, even as the hypercreature itself is multiple. My dissatisfaction with three-dimensional space—with its points and lines and locating politics—is not that it is too abstract, but that it is not abstract enough. 'Three-space' does not allow me to get into the mobile and sensuous morphologies of the subject: the multiple, convoluted and puzzling affective depths of the body as fluid and intercorporeal flesh. The 'I' as an inherently unstable being ... but never 'being', always becoming-other, becoming-self, becoming-world ... Three-space does not reach into the abstract morphologies that bond a wasp to an orchid, a motorcycle to its rider, a small child to her teddy bear, a smell to a memory, a tall building to 'terrorism', an event to an affect, a haircut to a song. In these bonds, one body somehow takes on a hue, or tracing, of its 'other'. Three-space is a Renaissance space, where each subject can stand alone. Hyperspace is a baroque space, where each subject exists in relation to its others, and where the body moves outside its own frame of reference, moves into becoming much more than what it is, moves among relations between itself and the space of its apprehension, and where the frame dissolves, only to re-emerge with a differing morphology.

A commitment to three-space creates a subject, and requires that subject to be interior. This subject is completed within its own frame of reference: the body becomes defined as a completed object with an interiority that gazes at an absolutely external outside world. It is a body that is supposedly passive, but at the same time it vigorously resists anything that is not itself. A three-dimensional object is given absolute points and positions: a cube has corners here, here, here and here, for instance. But there is no such thing as an individual object *in* the world, just as there is no such thing as ‘the’ body as a discrete entity that is capable of being investigated outside of the ways in which that body is performed. There are only co-members *of* a world. We are dealing here with a problem concerning the plurality of subjects, their relationship and their reciprocal presentation.

The hypercreature is not a singular entity: it is multiple, even if my nominalisation is singular, organic and objectifying. The hypercreature is none of these things exactly. It is not so much ‘post-organic’ or even ‘pre-organic’ so much as perhaps ‘co-organic’: cooperative organicism. I refer to ‘it’ as a ‘creature’, perhaps in a habit of anthropomorphic objectification, but the hypercreature is an incomplete ‘(not)thing-ness’ that draws me out and creates me as ‘thing’, self, body. But I must define the hypercreature somehow: I need to give it a sense of becoming-object even with an awareness that it isn’t. I must give the hypercreature a space to ‘be’, even as it is becoming.

The hypercreature is not ‘I’ to either ‘itself’ or myself. It is not me, but also not other: not object or fact or thing. The hypercreature is performance; it creates me and creates you in its mapping, but not the opposite: I cannot trace it on any map. I can only get an occasional fleeting glimpse of what it might be, and this glimpse is an invention, for there is no ‘wholeness’ or ‘completion’ to the hypercreature. I must fill in the gaps for what is impossible to perceive fully or to know absolutely or to define.

The constructed binary between an internal subjectivity and an external objectivity was a seed planted over four hundred years ago. In the time since, through successive re-evaluations of the relationship between self and world, the seed of the solitary and disconnected mind has grown into a mighty arborescent structure that attempts to negotiate ways in which it can find absolute certainty and connection with ‘the world out there’. But why always this assumption of an excised mind, disconnected and contemplating the ‘outside world’? This mind versus world binary is a war between inside and outside; a war where the struggle for certainty becomes lost in the fear of losing contact with that outside world, and where humanity is terrified of being invaded by nonhuman as well as monstrously inhuman shrapnel

that would tear 'our humanity' to pieces. But I am not at war with this world, and my body is not just a vessel for 'the mind'. My corporeality is part of this world, human, non-human as well as the monstrously inhuman.

I am not divided by having an internal mind that is in control over an inert and receptive body. It is just not that simple or complete or absolute. Myself as subject is much more than the duplicity given to me by the Cartesian binary. I am not divided, but multiplied. 'Science' (with a capital S) is that which attempts to remain autonomous and detached in its impossible task of 'uncovering the real', and it's this bloodless and objective Science that wrote the law, made up the rules, and decided what belonged to mind and what to body, what to science and what to art. This type of Science doesn't understand multiplicity, nor does it understand a law that is continually evolving and morphing into spaces of becoming. The universe has no static laws that can stand outside a perception of 'universe', any more than a mind can exist without a body. The body is not just 'connected' to a mind: the body is the mind. Flesh is mindful. Laws of the universe are made up by that universe as it evolves, or perhaps creatively 'involves'. The cosmos is not benign but is intelligent in itself, and it folds and involves, emerging out of not an unchanging eternity, but an evolutionary becoming.

The construct of an outside world functions in a non-dimension that is given to be absolutely outside of relation. But there are no dimensions and no world that is outside relation, or absolutely outside self. When a world, a universe emerges as the self, when the body 'is the world'—part of the dynamic worldly inter-being—then we no longer have need for binaries of inside and outside. The hypercreature has no concept of a unified, singular and self-contained subject: it is not even a possibility. There can be no binary distinctions to the hypercreature between subject and object, me and world, self and cosmos, mind and body.

Points and positions within a hypercreature are not absolute; they vibrate and resonate, sliding in and through positions, slipping in and out of focus, and echoing in distant reaches of space and time. The movement of these components within the hypercreature creates lines or arcs; every hypercreature has an irregular contour defined by the multiplicity of its components. The hypercreature is a whole because it totalises its components, and it is upon this condition of totalisation that it escapes the fractal chaos constantly threatening it, stalking it, trying to reabsorb it. In our conversation of speaking now, between writing and reader, you and I inspire a projection, a line that vibrates within a hypercreature, sending out blocs of sensation—percepts and affects—but these blocs, while being collective, are not universal concepts. Our 'conversation' is not real, or not yet, but it exists nonetheless. These arcs resonate according to the dimension considered, and are not a unit of measurement, but are inter-

dependently defined. These are non-absolute relational lines, reaching between you and me, between you and that object, between that object and the next, and so on. These lines are autopoietic but not inherently connected: they are motivated through the event of interrelation.

The collectivity or percepts and affects are neither individual, nor simply 'social'. Percepts and affects have an intensity and an autonomy that resist both presence and absence, and instead are sonorous blocs of sensation—refrains of gesture and style that (de)compose the flesh, which territorialises that bloc. The spider's web contains a very subtle portrait of the fly which is a portrait that is drawn by the hypercreature. The plane of the hypercreature ascends irresistibly and invades the plane of (de)composition in the realm of the senses that are not *in* the body, so much as *of* the body. The affective gesture of the hypercreature does not stay within the body; it does not begin with the body, and it unfolds back to the bloc of refrain that is the hypercreature.

In its creativity, those creatures or components that are part of the hypercreature do not 'form' it, or even 'inform' it, but rather inspire the hypercreature, as it inspires me. Creativity is not informed, but inspired. Creativity is a living and breathing of things: creatures 'breathed life into' through the hypercreature. I am always the measure of something else, of someone else, and yet I also am a measure of myself. I am written, but this has nothing to do with signifying. The hypercreature does not signify me, so much as arouse me. I am created not from a projection of the hypercreature that would be a willed, determinate arc of reference, rather the hypercreature gives me the possibility of becoming, and thus I am. The hypercreature breaches me: it intrudes upon my body, my self, my being, transgressing my corporeality in a process of a signifying rupture. In becoming you I do not mimic you, reproducing your actions into my own flesh. Within the hypercreature your pattern is remembered, and drawn through my flesh. My memory is not a memory remembering you as an object, located in some filing cabinet in my mind, but rather re-members the *re-membering* of you. I know you, and I know it is you when I see, hear, touch, taste and smell you, not because I know that particular object (the 'actual' sound of your voice), but because I recognise the re-membering of your voice, which is a corporeality habituated not *in* my flesh, but *as* my flesh. To be deterritorialised is to become reterritorialised: two becomings intertwine and inspire relays in a circulation of intensities pushing deterritorialisation even further.

This doesn't destroy me, so much as send me down another path of possibility—a detour or a line of flight—that always cuts back to my flesh. The hypercreature gives me this possibility of self-eruption. I am destabilised, encountering that which is not-self, encountering sometimes menacing, sometimes helpful others where I penetrate and am penetrated, by the vile and the disgusting, as well as the beautiful and the serene. Good and bad occur from the vibration of events within this flesh, as affect and percepts unfold as my flesh, and the re-membering of the flesh is the performativity of decisions of good and evil. The

good, the bad, the beautiful and the ugly are real-ised through the rupture of affect, drawing me to connections that (de)composes me as an ethical and political body.

There is no difference between what the self articulates and how she is made. The self already is her gestures. She is nearly a hypercreature or perhaps a virtual hypercreature, as much as the hypercreature is a virtual self. She is swept along by the abstracting performativity of the hypercreature. She is no longer producing or reproducing the performance; she feels herself at the service of the gesture: it moves through her and erupts so suddenly that she must dash forth to follow where it leads. The only question is this: to which other gestures that make her a self is she plugged into? This is not ideology, it is assemblage: a method of composing what becomes a three-dimensional work. I am a work of the hypercreature: it draws me, paints me, invents me and inspires me, from the palette of the arc that is the capacity of my relational possibilities. And not only assemblage and composition, but also disassemblage and decomposition: the art of unfolding and involving is not accumulative but is created through intercorporeality. Unfolding is not a chronology of life and then death, but is (de)composition, which is a literal reincarnation and a reinvention of the flesh. The self is prevented from dying by death itself. That tree is my grandfather. Both gestures suggest a (de)composition of the involving art of a becoming flesh. Performative intercorporeality, real-ised.

The human body is not itself individualised as a genus: it has a 'thingy' history. Our bodies have never been separate to the technologies that we have co-evolved with: we have always been a hideous beast, part machine, part organism. Our bodies did not evolve 'fully formed' and then go on to find different ways of using technology, but evolved in the very act of using those technologies. Machines evolved *with* humans, not *from* them: they are, it might be said, fundamentally part of our 'nature', as we are part of theirs. Machines *corporeally* created us, as we created them. The hand evolved because of the tools that it was able to hold. The bodies of humans and the bodies of machines are part of an intercorporeal dynamic. In my relationship to a machine, the machine unfolds my body within the hypercreature, the arc of our relations stretching between us, and yet involving and splaying outwards into all other components within our realm. And this is only the most extreme example: all things have a humanity; all humanity has thingness.

I must emphasise: the hypercreature is not God. No, that would be a mistake. For God, by convention, is omniscient: God knows all and touches all. The hypercreature is not omniscient, although its 'intelligence' functions differently from my own, and I am intelligent only

because the hypercreature has intelligence. The hypercreature, like God, is infinite, but this infinity, for the hypercreature, is a fractal infinity that is not immortality. The hypercreature is not necessarily or only an intentional or purposeful relation, not only an immediate or present relation, but also a relationship that *can be*. The hypercreature articulates possibilities, not determinations or judgements. It is not the benevolent space of God, but a performative morphology of intercorporeality: it is not Being, but becoming.

Every body within the hypercreature, every component, cannot be simply and unproblematically connected to every other component in the universe. All hypercreatures are connected to events, which can be isolated only as clarification emerges and without which the hypercreature would have no meaning. That is to say that an event of becoming can only take place because a system of eventfulness has already anticipated that moment. Vision does not emerge and then go on to see: vision is a resolution of the possibility for seeing. This may seem illogical: that a body (or organ, thing) only emerges after the clarification of an event that it was part of setting up. But the hypercreature brings into play a pre-individual reality that is unfolded in relation to other bodies, culminating in those bodies-in-relation containing as possibilities that reality. Vision comes to fruition when, in a non-predetermined gesture (a roll of the dice), possibilities come together to create what becomes functional as 'vision'.

I am not restricted to one hypercreature, but exist within multiple hypercreatures. I am moved between hypercreatures in a kind of passageway: a doorway, perhaps, or a bridge that is filled with monstrous multiplicity. In this passageway are bodies that threaten to expose our multiplicities: bodies that are ourselves, but are bodies that are our grotesque imperfections, our non-human and inhuman components. These passages have the possibility of destroying us, but it is because we complete the pass that we gain a sense of wholeness. In this unfolding, I am not other, I become-other-becoming-self. The world is continuously unfolding into self, although that movement is also, necessarily, a movement 'from' self. My body is not the origin from which relation to world arises: the hypercreature is an inspiration of the relational spaces in which I am intertwined and from which 'I' emerge.

A subject that is either completely internal and separate or, conversely, completely 'at one' with the world—in an undifferentiated unity—is a subject that has no foothold in the world, no basis upon which she is a political figure, an identity, part of a collective, a nation. If she were simply connected unproblematically to all, she could not be a lover or even the combatant of another, because binary constructions of inside and outside and world only 'out there' close off the pathways of imagination, as well as creativity and destruction, and

the possibility for any sort of affect, love or hate. Completely inside or completely external, solipsism or anarchy, either way it is chaos and madness, pure and simple.

In order to be myself, I must be someone else, but the irony is that I have to be willing to step into some sense of sovereign bodily existence from the other in order to have the strength to leave that self behind and migrate into the relational spaces of becoming-self and becoming-other. I might feel an impulse to think that no-one can ask me who I am and no-one can ask me to remain the same, but without a sense of definitive self, what proof do I have that I exist? If I do not step into myself as 'a body in the world' and as an identity, then I cannot 'be', no matter how much that self is always a relational becoming-flesh. I find a sense of belonging to this body that is me, and the desire to belong to *something* is the desire to *know*, to love and be loved, to feel that there is meaning to our lives, to be needed and known as 'I'. We need to belong in a sense of self: without that, I have no meaning of self or other or world.

The polymorphic hypercreature has multiple faces, multiple attitudes. The one that faces me is that which makes it a kind of creature, a kind of organism, and which creates me as self. Another face of the hypercreature reaches in, toward other possibilities, which is what continually destratifies and deterritorialises me, bringing me within the reach of pure possibility, and yet always thrusting me, sometimes violently, outside of myself. I lose myself sometimes, and experience affects and percepts that wrench my corporeality into sometimes painful, sometimes joyous, conditions of 'being moved'. I am always 'being moved' in becoming, but I feel this affect most profoundly, most intimately, in experiences of awe, surprise, grief, disgust, embarrassment or the intensity of sexual desire. I am in this space of affect when I lose myself in writing—and always in the erotics of pedagogy—where my corporeality is held within the vibrating, quivering space of the arc of affect that is drawn by the hypercreature. This affect is not a 'feeling', just as a percept is not 'perception': they are independent of those who experience them, and the arc goes beyond the strength of those who undergo them. What is preserved in these moments is a bloc of sensation, although the difficult thing is to say where in fact the body ends, and the arc of the percept and affect begins. In these arcs the history of self that resounds in my flesh ruptures, re-negotiating new pathways, new arcs, new vibrating positions of becoming. Sensation is not 'embodied', it is intercorporealised, shooting in and through and out of the unfolding body.

I am not singular, I am multiple, polymorphic. I myself am not a hypercreature—at least, not on this plane—but the traits of the hypercreature resound through my flesh. The hypercreature is both within me and beyond me. I am intimately part of it, as it is intimately

part of me. It moves through me, it breathes me. My flesh is caught up in its curving, resounding, penetrating gestures. I am a multiple, vibrating point to the hypercreature: the hypercreature is a vibrating hyperrealm of points, lines, arcs and shifting dimensions. I am a dynamic point within the hypercreature that reverberates and fills a dimension, which morphs in the gesture of connection made through this dimension. This is the performativity of the hypercreature: multiplicities of self, of dimensions and morphologies that sonorously reverberate throughout the flesh. I am penetrated with the morphyic resonance of affect and percept, which is a space that has memory and is re-membering my flesh. The multiple dimensions differ in their velocities, temporalities and manifestations, but always in relation to the components that slip through those dimensions.

As a work of the hypercreature I am pugged into others, in lines, in segments, in fractals, in parts. Hypercreature within hypercreature, self within self. Inside, outside, who cares to say what is 'I'? It is no longer important, or even a valid question to a hypercreature. What parts belong to me, what to you? Whose words are these that I write now? The line of origin was always already broken, even before the words were written. *Flesh, corporeality, intercorporeality, body, intertwining, materiality*—all of these concepts, as hypercreatures, must necessarily change shape, become reconstituted, as they shift through the intertwining of bodies and of texts. Nature is not 'natural'; it is enchanted, which is to say that it is creatively involved in the performances through which it is real-ised. Writing, self, can never be taken back to original and separable parts. Chiasmus, intertwining: never back to what they were before our paths crossed, retaining reverberating affects and events resounding through involvement. The hypercreature rhizome flesh draws out these words from our foaming, pulsing relation. From one writer to another (and another, and another ...) great creative affects diverge and connect, with compounding sensations transforming, vibrating, coupling or splitting apart. These words are not mine, but they become mine by connection, drawn from a line of flight into the pulsating point of my flesh. The hypercreature, too, is always splitting apart, rupturing across planes of immanence, similarly through outcomes of rolls of the dice.

The hypercreature is fractal. The ant colony, the rat pack: a unity performing a bundle of bodies within it. A body of work containing bodies of work, within other bodies, and so on. The individual is not unique: subtract the unique from the body of work; the body of the subject, the body of the object. The individual is not the stand-alone Renaissance figure, assuming a composed subject, but is a fractal flesh, where the individual and the event are infused into each other. Microcosm and macrocosm are not two sets joined by a common

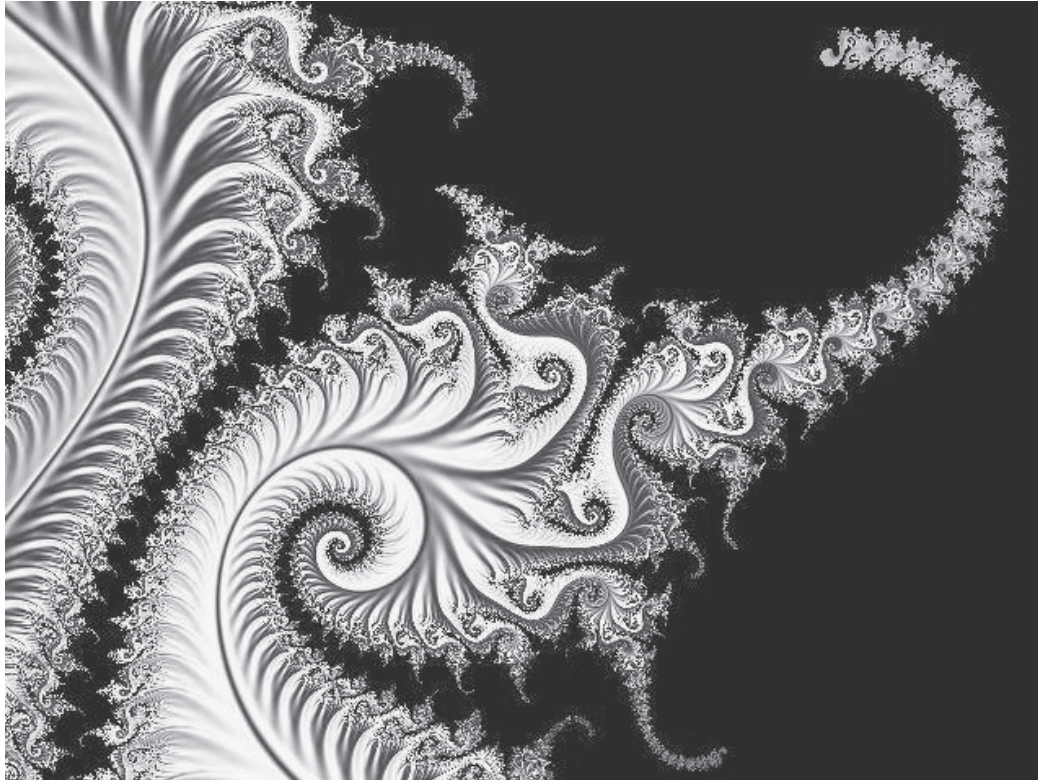

Fractal image created using Ultra Fractal 3 <www.ultrafractal.com>

area of interaction, but a fractal concept, where micro and macro burst out from each other, in sometimes violent array: explosions of resolution and disappearance, slipping through uncertain and ambiguous tides of convergence and disjunction.

The filaments of the fractal reach out, beautifully, tenderly, toward each other, and towards nothingness and the edge of infinity. Dividing infinitely, destratifying into smaller and smaller planes, receding, and yet also exploding in violently beautiful turns of twisting, curling, affective unfurling. Clusters here and there, patterns emerging, memory, falling away into nothingness. The microcosm and the macrocosm pull at each other, twisting and flailing about: a floppy fish that refuses to settle, always sliding and inverting ... I follow a line in, further and further, until it becomes the tiniest filament ... only to suddenly have the macro come crashing in, erupting into my vision. In a collapse of perspective, the whole enormous spiral suddenly becomes only the tiniest sliver of a curl, on an infinitesimal speck of a micro-spiral arm, on the edge of forgetting ...

Departing in a movement of deterritorialisation, a line of flight, creating another possibility, another velocity, I am moved. I have been aided, inspired and multiplied with you, and thus we must necessarily part, for I cannot be you, even if I am never really myself. Arched outwards, reaching to the outside and unfolding from within, the hypercreature turns

another face towards another possibility, which then becomes wrapped into self. My flesh involutes, and what is outside is also my inside: my self arrives from without, from that strange morphic space that arises when two plus one equals several parts more than three. It is not addition, never can be addition, and is not even multiplication. One thing does not necessarily follow another: cause is not followed by effect and what comes before does not necessarily have to be invoked in order to 'know'. Morphic space defies a simple mathematics. It is a maths that requires imagination, event, affect and percept to fill in the gaps. It is not illogical or unreasonable, but it is a different kind of logic: a different performance of reasoning than a linear or arborescent or causal logic, a performative and acausal logic of sensuous unfolding. Morphic space comes out of where? and, once there, seems in the right place, to 'feel right'. Not destiny, but possibility, real-ised. And suddenly everything makes sense, if only for a moment. In the next moment, it's gone.

Morphic space is impossible to hold on to. It shifts and turns and disappears and appears. I suddenly have a moment of clarity, when I can image the hypercreature, but the instant I speak those words, that clarity has gone. I've killed it, by trying to look too closely; I've strangled it with the desire to Know, to uncover The Truth. 'Bare attention' or proceeding without intent or purpose into morphic space allows us to remove the limits of our thinking, opening up morphic spaces of creativity. Morphic space is a space that is within but arrives from without. Don't try hard, try softly, you'll see more than you real-ise. Sometimes looking too hard puts more obstacles in our way than looking gently. The intuition of morphic space is not my subjectivity, but the space of (not)thing-ness: the space where the clock hasn't yet ticked. The tick has been anticipated, but has not yet arrived. This is morphic space. This is the space of the hypercreature, the space the hypercreature reaches into, and through which unfolds a self, an object, a time and a place, at different speed, different dates. The clock ticks.

And so I digress: the hypercreature evolves. The multiple must not be made by adding a higher dimension, because hyperspace is not simply a case of addition. The outside is achieved, but only as a route to get to the fractal. The multiple dimensions of hyperspace are not achieved by adding on more dimensions. It is not progressive, not accumulative. Not positivist. Three plus one does not equal four. Hyperspatial dimensions are not simply appendages tacked on to or overlaid over the first three dimensions, because what hyperspace does is unfolds other dimensions. Through hyperspace, I can get into the realm of the involving cosmos, to arrive at the fractal, where the body of work is both inside and outside the self. And this is the hypercreature, at work. Russian dolls in hyperspace, hypercreatures polymorph into and out of each other: creatures within creatures within creatures. Where does one hypercreature end and the next begin, when hyperspace involves within and without, and hypercreatures shift and morph and slide into and out of each other in fractal

filaments of emergence and disappearance? This morphology is vastly different to the locating principles of Euclidean space, which plots a point and fixes a hierarchical order that defines and locates.

When hypercreatures link up with each other, articulate their respective gestures, they belong to the same event, even as they have different histories. Hypercreatures have become-ings that creatively involve the relationship of one to another on the same plane, in exactly the same mannerisms, the same performance, as me to you in relation. Do you see now how the body is a vibrating point in one dimension, but in another becomes a hypercreature? How a hypercreature in one dimension becomes a body in another? Can you see the fractal, reaching out, drawing you in, drawing you out, breathing thinking? Can you begin to see, and think, hyperspatially?

The hypercreature maps from morphic space, which might be said to be the 'outside of the outside' or perhaps even the 'inside of the inside'. This is a space that has no image, no signification, no subjectivity. This outside of the outside is not a negation (nothing), but a possibility of nothing: (not)thing-ness. It is not 'the great beyond', because it is here and now, although its temporality and speed run at varying rates in 'holes' or 'nodules' of space and time. Even if a body lives for only a short time, it will give sensation the power to exist and be preserved in itself in the eternity that coexists with this short duration. In this pinch of eternal duration, time and space are waiting for the moment to arrive, before they are realised. This is the moment just prior to the event: the imminent sound of the clock about to tick. Synergetically drawing pathways from this and from that and from (not)thing-ness, the hypercreature boldly emerges.

The human body does possess a genuine 'interiority', which plays a constitutive role, but this 'interiority' is achieved only on the basis that that interiority preceded the body's actual individualisation. Perhaps it might be said that a body wraps herself around a pre-individual nodule of metastability, which is brought into play and unfolded into the world. It is this pre-individual nodule—the hypercreature—that allows collective individuation so that the resolution of a body-in-the-world is at the same time a body of the collective, unfolding her political, ethical, sexual, and gendered corporeality. The body is within a metastable equilibrium where potential energy residing in a given system provides the hypercreature with an internal resonance, which modifies its relationship to its milieu, but is also modifying itself through the constant reinvention of self-becoming.

Trying to locate absolute points within the hypercreature, like trying to locate an absolute subject for the world, is futile, because they are within a system in which this body that I

am—this flesh that is ‘me’—is a corporeality that is *literally* a cultural body. The body is intercorporeal flesh, performative of her dynamic cultural milieu. The body that is me is world-flesh, flesh of the universe, part of the cosmic breath of the universe. This flesh that I am is always creatively announcing her cultural, sensual and imagined environment, through the unfolding of the hypercreature. Perceptions that I have are inspired through my interactive, intercorporeal cultural body, through relations that I live within the space of. This is the space of the hypercreature. I am within a relation to you, but that relation is not fixed. It is a relation inspired at the moment of becoming. In another moment, another sensation, another event, at different dates and speeds, we are differently aligned and inspire a rather different projection. To attribute to myself—as one particular point—a singular subjectivity is to overlook the working of matters: the morphologies of our becoming self and the exteriority of our relations. Deterritorialised, destratified, our lines of flight articulate themselves within a polymorphous network, and thus I am undone.

Always surveying, mapping, unfolding, the hypercreature traverses its components according to an order without distance, immediately co-present to all its components, *itself* passing back and forth through them. Through its components, the hypercreature writes in realms that are yet to come. You are already and always *of* me, unfolding my body and exposing my subjectivity to the world. ‘Your’ flesh is unfolded through our intertwining, through ‘my’ flesh. The world that is unfolded throughout the flesh is the morphic and eventful space of ‘possibility for thing-ness’, which is the realm of the hypercreature. As event unfolds, it inspires the self that I become. Self and world, self and other, resonate in a morphic field of intercorporeal and affective space. The world feels me and knows me. These are the events of real-isation.

Thanks to Alan Massie, Stephen Muecke, Katrina Schlunke and Roger Haden for their support. Also thanks to Anne Brewster and the anonymous readers whose comments and suggestions were very helpful. Thanks to Drew Olbrich for the use of his hypercube images. This essay is dedicated to Edwin Abbott Abbott, a schoolmaster, who, in 1885 dared to write a book, *Flatland*, about the romance of geometry.

RAYA MASSIE is a doctoral candidate in writing and cultural studies at the University of Technology, Sydney, where she also teaches fictocritical writing. Her ‘creative PhD’ researches cultural corporeality and ‘baroque post-humanism’, with a particular interest in monstrous performativity. <raya.massie@uts.edu.au>

- Edwin Abbott Abbott, *Flatland: A Romance of Many Dimensions*, Roberts Bros, Boston, 1885.
- Gaston Bachelard, *The Poetics of Reverie: Childhood, Language, and the Cosmos*, trans. Daniel Russell, Beacon Press, Boston, 1971. ('Cosmic breathing', p. 179.)
- *The Poetics of Space*, trans. Maria Jolas, Beacon Press, Boston, 1994 (1958). ('Our words think for us', p. xxxix.)
- Thomas Banchoff, *Beyond the Third Dimension: Geometry, Computer Graphics, and Higher Dimensions*, Scientific American Library, New York, 1990. (Technical information regarding geometry and higher dimensions.)
- Roland Barthes, *A Lover's Discourse: Fragments*, trans. Richard Howard, Penguin, London, 1990 (1977), pp. 3–4.
- Maurice Blanchot, 'The Instant of My Death', in Werner Hamacher and David E. Wellbery (eds), *The Instant of My Death/Demeure*, trans. Elizabeth Rottenberg, Stanford University Press, Stanford, 2000 (1994). ('Prevented from dying by death itself', pp. 1–11.)
- Paul Carter, *Baroque Memories*, Carcanet, Manchester, 1994, p. 27.
- Gilles Deleuze, *The Fold: Leibniz and the Baroque*, trans. Tom Conley, University of Minnesota Press, Minneapolis, 1993. (A significant influence, specifically in relation to the concept of folding and unfolding and the concept of 'real-isation'.)
- Gilles Deleuze and Félix Guattari, *A Thousand Plateaus: Capitalism and Schizophrenia*, trans. Brian Massumi, University of Minnesota Press, Minneapolis, 1987. (Specifically 'Rhizome' and 'Becoming' chapters, where I have, at times, re-written their words in terms of hypercreature. The essay contains many re-written sentences from 'Rhizome', which was the essay's original inspiration.)
- *What is Philosophy?*, trans. Hugh Tomlinson and Graham Burchell, Columbia University Press, New York, 1994 (1991). (Also a significant influence, specifically their discussions in 'What is a Concept?', where I have sometimes switched 'concept' for 'hypercreature'; 'Percept, Affect, and Concept'; and 'Conclusion: From Chaos to the Brain', particularly in regard to chaos, thought and planes.)
- Michel Foucault, *The Order of Things: An Archaeology of the Human Sciences*, Vintage Books, New York, 1994 (1970). ('Do not ask me who I am and do not ask me to remain the same'.)
- Ann Game and Andrew Metcalfe, *Passionate Sociology*, Sage, London, 1996. (Writing and thinking passionately.)
- 'Creativity and Knowledge', seminars, Department of Sociology, University of New South Wales, 1998. ('Don't try hard, try softly' and concepts of thinking creatively.)
- 'Belonging', unpublished paper, 1999. ('Spaces of belonging' concepts).
- Mark Hansen, 'Internal Resonance, or Three Steps Towards a Non-viral Becoming', in Dave Boothroyd and Diane Morgan (eds), *Culture Machine*, vol. 3, 2001, <culturemachine.tees.ac.uk>. ('Post-organic'.)
- Vicki Kirby, 'Post-human Subjects', lectures, Department of Sociology, University of New South Wales, 1998. ('We are the world' concepts and 'nature' as enchanted.)
- Bruno Latour, *We Have Never Been Modern*, trans. Catherine Porter, Harvard University Press, Cambridge, 1997 (1991). (Thinking through the relationships between movement and stasis.)
- 'Do You Believe in Reality? News from the Trenches of the Science Wars', *Pandora's Hope: Essays on the Reality of Science Studies*, Harvard University Press, Cambridge, 1999. (A significant influence: 'Science', questioning the 'outside world', the 'thingy' history of humanity, 'nonhuman', and 'collective'.)
- Brian Massumi, 'The Autonomy of Affect', *Parables for the Virtual: Movement, Affect, Sensation*, Duke, London, 2002, pp. 23–45.
- Bruce Mazlish, *The Fourth Discontinuity: The Co-Evolution of Humans and Machines*, Yale University Press, New Haven, 1993.
- Maurice Merleau-Ponty, *Phenomenology of Perception*, trans. Colin Smith, Routledge and Kegan Paul, London, 1962. (A significant influence in terms of thinking about the body; thinking and sensing the world, as well as concepts of intercorporeality.)
- *The Visible and the Invisible*, ed. Claude Lefort, trans. Alphonso Lingis, Northwestern University Press, Evanston, 1968. (Also a major influence: 'flesh' from 'The Intertwining—The Chiasm' p. 151, 'dash on bow', and 'sometimes helpful, sometimes menacing' p. 35.)
- Andrew Metcalfe, 'Nothing', unpublished paper, 1999.
- Andrew Metcalfe and Ann Game, *The Mystery of Everyday Life*, Federation Press, Sydney, 2002.
- Drew Olbrich, *Hypercube*, 2003, <www.traipse.com/hypercube>.
- Michel Serres, *Angels: A Modern Myth*, trans. Francis Cowper, Flammarion, Paris, 1995. (Process as intelligence.)
- *The Troubadour of Knowledge*, trans. Sheila Faria Glaser with William Paulson, University of Michigan Press, Ann Arbor, 1997 (1991).
- Rupert Sheldrake, *The Presence of the Past: Morphic Resonance and the Habits of Nature*, Park Street Press, Rochester, 1995. (The evolving universe and its laws.)

Gilbert Simondon, 'The Genesis of the Individual', trans. Mark Cohen and Sanford Kwinter, in Jonathan Crary and Sanford Kwinter (eds), *Zone 6: Incorporations*, Zone Books, New York, 1992. (A significant influence: 'metastable equilibrium' p. 301; 'individualisation', a 'group individual', 'collective reality' and 'pre-individual reality' pp. 306–7).

Phillip Toyne and Daniel Vachon, *Growing up the Country: The Pitjantjatjara Struggle for their Land*, McPhee Gribble Press, Fitzroy, 1984. ('That tree is my grandfather'.)

Gail Weiss, *Body Images, Embodiment as Intercorporeality*, Routledge, New York, 1999. ('No such thing as "the" body as a discrete entity', p. 1).