

UNIVERSITÉ DE MONTRÉAL

IMPROVEMENT DEBURRING CONSISTENCY OF FUEL NOZZLE PARTS

SEYEDEHSHAGHAYEGH ROUZMEH
DÉPARTEMENT DE GÉNIE MÉCANIQUE
ÉCOLE POLYTECHNIQUE DE MONTRÉAL

MÉMOIRE PRÉSENTÉ EN VUE DE L'OBTENTION
DU DIPLÔME DE MAÎTRISE ÈS SCIENCES APPLIQUÉES
(GÉNIE MÉCANIQUE)

MAI 2012

UNIVERSITÉ DE MONTRÉAL

ÉCOLE POLYTECHNIQUE DE MONTRÉAL

Ce mémoire intitulé:

IMPROVEMENT DEBURRING CONSISTENCY OF FUEL NOZZLE PARTS

présenté par : ROUZMEH Seyedehshaghayegh

en vue de l'obtention du diplôme de : Maîtrise ès sciences appliquées

a été dûment accepté par le jury d'examen constitué de :

M. LAKIS Aouni A., Ph.D., président

M. BALAZINSKI Marek, Ph.D., membre et directeur de recherche

M. HOANG Canam, Eng., membre et codirecteur de recherche

M. ENGIN Serafettin, Ph.D., membre

ACKNOWLEDGMENT

My special thanks are extended to my father for his dedication and support and my mother for the love and strength she gave me.

I would also like to express my profoundest gratitude to my research director, professor Marek Balazinski, for his support and patience and for the kindness in his heart, which makes him more than an advisor to me.

I would also like to offer my sincerest appreciation to my industrial supervisor Mr. Canam Hoang, which his support, expertise and advises helped me conducting this project.

Finally, I wish to acknowledge the support of Pratt and Whitney Canada, for enabled this study to be performed.

RÉSUMÉ

L'objectif de cette étude est d'améliorer la qualité produite par l'ébavurage des pièces de tourbillon d'air. Ces pièces de haute précision sont habituellement ébavurées de façon manuelle par un humain. Comme première étape vers l'amélioration de ces ébavurages, l'analyse des causes fondamentales a été réalisée. Puis les conditions actuelles des pièces ont été étudiées par des expériences utilisant la méthode de Taguchi. L'analyse de la variance a été menée sur les données recueillies pour illustrer la significativité des facteurs des plans d'expériences et de leur contribution. La formation de bavures sur les pièces a été étudiée, trois régions principales ont été analysées. Le modèle cyclique de formation de bavures a été observé à l'état d'équilibre de la formation de bavures. L'amélioration du profil de bavure a été réalisée suivant deux méthodes : 1) le liquide de refroidissement à travers les trous d'huile du foret et 2) en position verticale du perçage. Le procédé d'ébavurage avec des abrasifs magnétiques a été évalué comme une alternative possible pour l'ébavurage manuel. Les échantillons ont été traités sous deux conditions : 1) pas de préparation en sortie de trou après perçage et 2) sortie de trou préparée. Les échantillons dont leurs arrêtes (sorties de trou) ont été préparées, ont montré une amélioration significative en terme de régularité.

ABSTRACT

This study is about improving the deburring consistency of air-swirlers. The parts are high precision critical components of hot section of aircraft engine, which have key role in stabilizing the combustion flames via providing turbulent air-fuel mixture for the combustion chamber. The product needs to meet high standards including edge quality and surface finish. These small in process parts are deburred manually due to their size, complex geometry, restricted access and adjacent critical surfaces to the edges.

The title of the research was selected through investigations, cost estimation and prioritization of deburring issues within Pratt and Whitney Canada.

In order to tackle the issue, a comprehensive study was conducted on state of the parts. The investigation aimed to lay a basis of comparison to evaluate the further improvement approaches. The parts were investigated through experiments, designed based on Taguchi method. For designing the experiments, root cause and fault tree analysis was performed first. Then the preliminary experiments were employed to define the level of affecting parameters. The designed experiments were conducted on four different in process parts. The data was analyzed using STATISTICA software. Based on the results, the areas, which required further investigation, were identified and feasible improvement strategies were proposed.

The complementary experiments comprise two main topics: burr control and alternative deburring process.

In order to improve the burr characteristics of the parts, burr formation study was conducted. The parts were assessed during various manufacturing cycles. Burr formation pattern was identified on the parts. Based on observation it was concluded that the pattern could be attributed to the temporary degradation of tool properties due to elevated temperature cutting during short time intervals. Hence, the temperature of the cutting tool was measured during production via thermal sensors. With respect to validation of hypothesis two main strategies were proposed in order to provide proper and homogenous cooling to reduce the tool temperature during the cut: Coolant thru design drill and vertical position for production. Both approaches revealed significant results. The burr height decreased and burr profile improved using both methods.

The feasible alternative deburring processes were assessed and listed. Among the proposed ones, magnetic abrasive deburring was selected for the test based on probability of success and project budget. The samples were processed in their original condition and with prepared edge. The preparation was performed manually. The operators were asked to remove the burrs without creating break edge. The unprepared samples had burrs and rolled edge after the process while the prepared samples had fine and uniform break edge around the part. The deburring results of prepared samples were remarkably consistent from hole to hole and part to part.

TABLE OF CONTENT

ACKNOWLEDGMENT	iii
RÉSUMÉ	iv
ABSTRACT	v
TABLE OF CONTENT.....	vii
LIST OF TABLES:	x
LIST OF FIGURES	xi
LIST OF ABBREVIATIONS.....	xiv
INTRODUCTION	1
CHAPTER 1 PRE-PROJECT PHASE.....	5
1.1 Methodology	5
1.1.1 Project Distribution	7
1.1.2 Prioritization Criteria	7
1.2 Result	9
CHAPTER 2 PROBLEM DEFINITION AND APPROACH	11
CHAPTER 3 BURRS IN DRILLED HOLES.....	14
3.1.1 Burr phenomenon and characteristics.....	14
3.2 Burr formation in drilling process.....	18
CHAPTER 4 BURR REMOVAL AND DEBURRING PROCESSES	22
4.1 Edge requirements	22
4.2 Hand deburring.....	23
4.3 Abrasive jet deburring	25

4.4	Electropolish and Burlytic Deburring.....	27
4.5	Cryogenic Deburring (Via Liquid Nitrogen).....	29
4.6	Thermal Energy Deburring	30
4.7	Magnetic Abrasive Deburring.....	31
4.8	Laser Deburring	32
CHAPTER 5 METHODOLOGY.....		34
5.1	Investigation of current state of the parts	34
5.1.1	Planning the experiments	35
5.1.2	Implementation.....	49
5.1.3	Analysis.....	50
5.2	Complementary experiments.....	50
5.2.1	Investigation of burr formation during manufacturing	51
5.2.2	Evaluation of alternative deburring processes	52
5.3	Inconsistency criteria.....	53
CHAPTER 6 ANALYSIS, RESULTS, AND DISCUSSION		55
6.1	Preliminary tests.....	55
6.1.1	Preliminary investigation of machining process	55
6.1.2	Preliminary investigation of deburring process.....	58
6.2	Statistical analysis of experimental data.....	61
6.2.1	Part A.....	61
6.2.2	Part B.....	65
6.2.3	Part C.....	69
6.2.4	Part D.....	73

6.3	Improvement Strategy.....	75
6.3.1	Modifying the burr size	75
6.3.2	Improvement of deburring process	78
6.4	Complementary Experiments.....	84
6.4.1	Burr Formation and Burr Minimization Strategies.....	84
6.4.2	Deburring and consistency.....	95
	CONCLUSION	100
	BIBLIOGRAPHY.....	104

LIST OF TABLES

Table 1-1: Summarized prioritization results.....	10
Table 4-1: Manual Deburring tools [20]	25
Table 5-1: Modified array $L_{16}[4^5]$ [67].....	49
Table 5-2: Experimental runs	49
Table 5-3: Magnetic abrasive deburring experimental runs.....	53
Table 6-1: Summary of ANOVA for break edge (Part A).....	62
Table 6-2: Post-hoc tests for burr size (Part A).....	64
Table 6-3: Summary of ANOVA for break edge (Part B)	67
Table 6-4: Summary of ANOVA for break edge (Part C)	70
Table 6-5: Summary of ANOVA for break edge (Part D).....	73
Table 6-6: Alternative deburring processes	81
Table 6-7: Inconsistency of measured break edge for samples from regular and coolant thru drill processes based on three main criteria	95
Table 6-8: Inconsistency of measured break edge for manual and magnetic abrasive deburring	99

LIST OF FIGURES

Figure 2-1: Schematic of an air swirler	11
Figure 2-2: Schematic of consistent profile (a), and Inconsistent profile (b) around the hole.....	12
Figure 2-3: Break edge variation of holes around the part.....	12
Figure 3-1: Burrs Inside and outside of theoretical intersection [21]	14
Figure 3-2: Burr geometry [22].....	15
Figure 3-3:Schematic of burrs created by plastic deformation [11, 24].....	16
Figure 3-4: Schematic of burr formation in ductile and brittle material [26]	17
Figure 3-5: Three types of drilling burr of AISI 4118 (a) Uniform burr with a drill cap; (b) transient burr; (c) crown burr [18].....	19
Figure 3-6: Two types of drilling burr of AISI 304L. (a) Uniform burr with drill cap; (b) crown burr [18].....	19
Figure 3-7: Formation of different burr types during drilling [14, 19]	20
Figure 3-8: Formation of uniform burr [18, 19].....	20
Figure 4-1: Edge quality classes [23].....	23
Figure 4-2 : Effecting parameters of abrasive jet deburring process [34].....	26
Figure 4-3: Schematic layout of abrasive jet machine [35]	26
Figure 4-4: Electropolish deburring tank.(courtesy Electro Glo Company)[15]	28
Figure 4-5: TEM deburring process[43]	30
Figure 4-6: Schematic of magnetic abrasive barrel finishing [39].....	32
Figure 5-1: Process flow diagram	37
Figure 5-2: Fault tree graphically represents the events, which cause the inconsistency of break edge.	38
Figure 5-3: Air-swirler manual deburring steps	40
Figure 5-4: Air-swirler holes after applying grinding wheel	41
Figure 5-5: Hole edge after applying round file.....	42
Figure 5-6: The wavy break edge created by the file (a) becomes smoother and larger after buffing operation (b).....	42
Figure 5-7: Schematic of the holes on the samples	52
Figure 6-1: Observed burr height valused for the samples gathered from two manufacturing runs	57

Figure 6-2: Average Burr Height VS Total Tool Life	57
Figure 6-3: Remained burr on the edge after applying grinding wheel	59
Figure 6-4: Wavy break edge created after filing (A), Enlarged and smooth break edge after buffing (B)	59
Figure 6-5: Observed break edge values for the filing and the buffing	60
Figure 6-6: Bar graph of observed break edges after the filing and the buffing operations	61
Figure 6-7: Effect of burr size level on break edge (Part A)	63
Figure 6-8: Effect of operator on break edge (Part A)	63
Figure 6-9: Effect of burr size and operator on break edge (Part A)	64
Figure 6-10: Residuals vs. predicted values (Part A)	65
Figure 6-11: Burr on the edge of the holes after free cut	66
Figure 6-12: Observed burr height values (Part B)	66
Figure 6-13: Effect of burr size level on break edge (Part B)	68
Figure 6-14: Effect of operator on break edge (Part B)	68
Figure 6-15: Effect of burr size and operator on break edge (Part B)	69
Figure 6-16: Residuals vs. predicted values (Part B)	69
Figure 6-17: Observed Burr height values (Part C)	70
Figure 6-18: Effect of burr size level on break edge (Part C)	71
Figure 6-19: Effect of operator on break edge (Part C)	72
Figure 6-20 : Effect of burr size and operator on break edge (Part B)	72
Figure 6-21: Residuals vs. predicted values (Part C)	73
Figure 6-22: Effect of burr size level on break edge (Part D)	74
Figure 6-23: Effect of operator on break edge (Part D)	74
Figure 6-24: Effect of burr size and operator on break edge (Part D)	74
Figure 6-25: Residuals vs. predicted values (Part D)	75
Figure 6-26: Producing small and repeatable burr	76
Figure 6-27: Reducing human error	79
Figure 6-28: Reciprocating file (Courtesy NSK)	80
Figure 6-29: The part and the tools	85
Figure 6-30: Average burr height of the parts and tool wear regions	86
Figure 6-31: Small and regular burr in Region I	86

Figure 6-32: Burr formation pattern in Region II	87
Figure 6-33: Temperature during cutting	88
Figure 6-34: Burr on three different holes of one part in Region III	90
Figure 6-35: Burr height on the holes produced by different methods	91
Figure 6-36: The drill caps created during current manufacturing process (a), vertical machining (b) and, using coolant thru drill (c).....	92
Figure 6-37: Burr on large holes	93
Figure 6-38: Burr height on the large holes produced in horizontal and vertical positions	94
Figure 6-39: Burr on the holes of part A before (a) and after the process (b) and (c)	97
Figure 6-40: Burr on holes of part B before (a) and after the process (b)	97
Figure 6-41: Burr on holes of part D before (a) and after the process (b)	97
Figure 6-42: The prepared edge without burr and break edge (a) and the break edge around periphery after magnetic abrasive deburring (b).....	98

LIST OF ABBREVIATIONS

AJM	Abrasive Jet Machining
ANOVA	Analysis of Variances
CRIAQ	Consortium de recherche et d'innovation en aérospatiale au Québec
CW	Continuous Wave
DOE	Design of Experiments
P &WC	Pratt and Whitney Canada
TEM	Thermal Energy Method
TTL	Total Tool Life

INTRODUCTION

Regarding the development of new manufacturing techniques in aerospace industry in addition to the capacity of manufacturing complex geometries and difficult-to-machine materials, costumers raised novel demands. The manufacturers are expected to provide large quantities of high quality products in small dimensions. One of the most significant criteria of quality is that of the edges. Burr-free products with large break edge or radius are in favor. Staying competitive in global markets calls for robust strategies to tackle manufacturing and quality issues such as deburring.

Canadian aerospace, as one of the world-leaders in the industry, has invested on various academic and industrial researches and projects related to deburring. MANU409, created by “Consortium de recherche et d'innovation en aérospatiale au Québec” (CRIAQ), was amongst the academic-industrial collaborative projects concerned deburring.

The objective of the CRIAQ Project “MANU409 Plan C: “Automatic deburring and part finishing” was to derive information regarding currently used deburring practices within Canada’s aerospace industry. The information included the techniques and the appliance stage of automation plus further-followed researches by companies and universities. Afterwards the information was classified to identify the research areas, which were more investable considering different potentials of the area.

Pratt and Whitney Canada (P&WC) has vested interest in this project to improve the current state of deburring, automation and quality of the products.

The topic of current study was extracted through technical surveys, cost estimation of the issues, and prioritization, which are addressed in the chapter of pre-project phase. The research was conducted in an industrial ambience and under academic supervision. The study aims to improve the consistency of deburring result of fuel nozzle parts.

The most important part in the hot section of an aircraft engine is the combustor. The main function of a combustor is to provide a reliable and smooth ignition by raising the temperature of the fuel and air mixture [1]. Stabilization of the flames is the most significant issue in combustion systems of aircrafts due to pressure change in combustion area. The shape of airflow plays an important role in stabilization of the combustion flames. In order to provide a homogenous air-

fuel mixture, which has a whirling flow pattern, air swirlers are employed as the most critical parts of the fuel nozzles [2]. These small components are involved with corrosion, high pressures, elevated temperatures, thermal and mechanical shocks through the combustion process[3]. The specific work condition of air swirlers necessitates the application of high standards of reliability and precision during manufacturing. The base material must exhibit outstanding mechanical properties at elevated temperature as well as corrosion resistivity. Hence, nickel alloys are favored choice for production of these parts. The parts are produced in small batch sizes. Numerous inclined holes are drilled through the parts, which intersect curved profile of the surface. The material properties and complex geometry of the part highly restrict the manufacturing. Furthermore, the machining is encountered with the issue of burr formation.

Nickel-Base alloys are used in wide range of industries such as aerospace turbine engines, aircrafts, marines, industrial and vehicular gas turbines, nuclear reactors, steam power plants and many other structural elements that experience high temperatures [4]. The alloys induce severe issues in manufacturing, which limit production options, particularly with precise parts. Aircraft engine parts are expected to meet high standards of quality and precision, consequently the quality of machining, including the workpiece edges, becomes of concern [5]. The surface and edge quality are important as they affect the corrosion properties and fatigue life of the part in addition to airflow and combustion performance [2, 6].The difficult-to-machine nickel alloys generate large material projections during machining. One of the difficult-to-treat features of the high precision air swirlers is the edge characteristic of the drilled holes. The parts must be delivered burr-free with substantial break edge, which is provided through deburring action. The edge dressing process can cost up to one third of total manufacturing expense for some machined components [7, 8].

The outstanding properties of nickel alloys that make them an excellent choice for critical applications also have the result of diminishing their machinability. The high strength of Ni alloys is not decreased in elevated temperatures of cutting. Due to the poor thermal diffusivity of these alloys, the cutting tools endure the heat intense of the cutting. The adhesion and chemical reactivity of nickel in addition to the presence of abrasive particles in the alloys dispose the tool to various types of wear[5, 9].

The manufacturing processes cause rough surface and undesired raised material on the edges which is called burr [10]. Dornfeld [11] defines burr as “a body created on a workpiece, which extends over the intended and actual workpiece surface and has a slight volume in comparison with the workpiece, undesired but to some extent, unavoidable”. The operators’ finger can be easily injured through assembly process as a result of presence of burrs and sharp edges. These small particles can part from the work piece during service and damage other components, exceptionally rotary and critical parts [7, 11, 12]. Although burr removal assure longer life cycle of the product, higher performance and simplicity of assembly and automation, it itself is a costly process. The cost of burr removal increases with geometrical complexity and high precision demands. For critical precise aircraft engine components the deburring can cost approximately 30% of total manufacturing cost [7].

Mechanical drilling is the most widely used process for producing holes through the manufacturing parts [13]. The drilling processes produce undesired bulge material on entrance and exit edges. The burr caused by plastic flow is defined as a burr, which must be removed for critical and precise parts [11].

1. Since the burr on the exit surface is considerably larger than the entrance burr, most drilling burr formation studies are focused on the exit burr [14]. The entrance burrs occur due to compression of material near the drill which leads to material flow along the tool edge (Poisson effect). Whereas the exit burr is typically an unsheared chip extended off the edge[14, 15].

Gillespie[16] was among the first researchers to offer a basic model for burr formation in drilling process. He also investigated the effect of tool geometry, cutting conditions and material properties over a wide range of experiment condition.

Stein [17] proposed a simple burr formation model in Titanium alloys. An inclusive burr formation mechanism was proposed by Kim [18] and Min [19] based on the study of drilling burr formation for low alloy steel AISI 4118 and stainless steel AISI 304. Kim [18] classified the burrs in three types : Uniform, Transient and Crown burrs. The basis of the classification is burr shape. Burr shape is of concern because the deburring cost is dependent upon the volume of the burr.

High toughness of nickel alloys in combination with excessive tool wear leads to formation of large burrs particularly in drilling operations[15]. Inconsistent burr profiles, small size of the features, restricted access, vicinity of critical faces and high cost of implementable techniques limit automated deburring options. Hence the parts are predominantly deburred manually. Currently most of deburring practices on precise parts are performed manually, which is the main source of inconsistency of the results due to repetitive action of the operator's hand, visual capacity and time-consuming trial of each operator. Moreover, the deburring time of manual burr removal process increases exponentially with growth of burr thickness [20]. Hence, the phenomenon becomes more of concern for nickel alloy parts specially once they are supposed to meet high quality requirements.

Delivering high quality product is a paramount in the aerospace industry. Current study aims to establish proper manufacturing and deburring strategies to improve the deburring consistency of air swirlers. The improvement is achieved through tackling the issue of controlling burr formation as well as employing automated techniques to deburr the parts. Producing small and regular burrs during manufacturing is advantageous as it decreases the cost of the issue, facilitates the manual operation and is an essential step toward automation. Selecting an automated process to deburr difficult-to-reach features of the part is another important challenge, which is addressed in the research.

CHAPTER 1 PRE-PROJECT PHASE

Pratt & Whitney Canada has started to provide an inclusive idea of the deburring situation within the company, which comprises 4 main purposes for this initiative:

Provide an idea of the deburring state at P&WC

- Verify the largest issues which have potential of improvement
- Develop a proper base for prospect work and improvements, which incorporate graduate student research projects and future methods development
- Prioritize the extracted research areas and appropriate foundations based on current real industrial facts and needs existing at P&WC.
- Perform research on prioritized projects in collaboration with academic institutes.

The first 3 goals mentioned above were obtained by the student team, which was working on the project until January 2010 and the results were reported to Pratt & Whitney Canada.

The work performed was based on data collection and investigations. The result was an inclusive report including the current deburring practices within P&WC, the major problems in each department, root cause analysis and suggested solutions which, ended up to defining 22 projects concerning all departments. The investable research fields were proposed to the company for future resource supply of graduate students, which will follow the projects.

The investigation results provided research areas and largest issues related to all departments in shop floor. The third goal addressed above was prioritization of these projects. This aim should have been realized by finding a basis of comparison between the projects, which are not technically in the same level of consideration.

1.1 Methodology

First, the 22 projects were adjusted through assigning to different departments. Hence some of the issues are generic and most of departments are involved with them, the distribution of research areas within departments led to 37 projects including both specific and generic ones. After the adjustment, the prioritization criteria were formed to determine the precedence of the projects, which are not technically comparable. The cost of the issue, the customer opinion and the probability of success were selected as the basis of comparison. Each criterion should be

presented as meaningful number or category. This aim requires a consistent database, which can be built by a reliable survey. The data gathering and modification was based on real facts and numbers. Furthermore the customer opinion, the previous deeds and the future purposes were inclusively considered. All the collected information were classified and presented in different matrixes. After that, the classified data is analyzed, modified and prepared to use for calculation.

The final calculation result was derived somehow that it could be representative of all the 3 criteria. Different parameters were applied and various graphics were demonstrated to prioritize the projects. Finally the results were discussed with the customer to confirm the prioritization.

As mentioned, each criterion was presented as a number or category. The real cost is the only criterion which could be calculated directly. To unitize the 3 criteria, a general formula was presented. The formula reflects the customer opinion and probability of success as well as the production cost.

The production cost varies per department and production line. Thus the generic projects were adjusted through dispersing within different departments. Then the involved family parts were extracted and the associated part numbers were allocated to each project. The customer was consulted in order to conclude the customer priority. The customer point of view was applied in general formula, which the evaluation based on. The percentage of possibility of realization was determined considering shop floor and engineering consults.

The general formula, which is used to estimate the adjusted cost of issue for each individual project is as follows:

$$\text{cost} = \sum \{ (\text{Production cost} + \text{Quality cost}) * (\text{Production volume of 2010} + \text{Production volume of 2011}) * \text{Customer priority} * \text{Probability of success} \} \quad (1-1)$$

Production cost for specific part number = (Deburring time + Machining time) * (Production line rate)

Quality cost for specific part number = Quality time*Quality line rate

Customer priority = 3 values are applied depending on customer opinion (1=low, 5=medium, 10=high)

Probability of success = Percentage of possibility of realization based on shop floor and engineering data

n = number of specific parts involved with project

1.1.1 Project Distribution

The 22 projects were proposed through previous work results, which contain the largest issues, root causes, suggestions and research areas. These projects covered both generic and specific issues within all departments. Due to different costs in various departments, common subjects were divided per department and family parts to alleviate the comparison. As a corollary the 22 projects were extended to 37 through assigning to different departments. For example tool wear is assigned to 4 different departments: Gas gen, Turbine and covers, Blades and Compressors.

1.1.2 Prioritization Criteria

To prioritize the adjusted projects, 3 main criteria were considered as the basis of decision:

- Real cost
- Customer opinion
- Probability of success

To conclude a consistent result from the general formula, it is necessary to clarify the part numbers associated with each project. The allocation of related part numbers was based on the following criteria:

- High Production volume
- High Production time (machining time, deburring time...etc.)
- Part complexity
- Automatic deburring requirements
- Deburring difficulties
- Quality problems (high scraps and rework)

1.1.2.1 Real Cost

The real cost of each project is assumed as the sum of production cost and quality cost for all associated part numbers in next two years (2010 and 2011). The mentioned terms will be clarified as follows:

Production cost

The production cost is the cost of production including the deburring cost and the machining cost depending on the project. There are different production lines within shop floor, which have different cost per hour. For each individual part number, the production cost calculated based on the deburring and machining hours and line rates. Then the production cost is multiplied by the production volume of next 2 years.

$$\begin{aligned} \text{Production cost per part number for next 2 years} = & \\ & (\text{Deburring hours} + \text{Machining hours}) * \text{Production line rate} * \\ & (\text{Production volume of 2010} + \text{Production volume of 2011}) \end{aligned} \quad (1-2)$$

Quality cost

The quality cost is the cost of the scrap and rework. There are different quality lines within shop floor, which have different cost per hour as well. The rework cost is calculated based on quality line rates and rework hours. The scrap cost is added individually. Since no exact scrap cost and rework hours exist before manufacturing the parts, the rates of the year 2009 were used as reference. The calculated quality cost of each part number in 2009 is multiplied by the production volume of next 2 years.

$$\begin{aligned} \text{Quality cost per part number for next 2 years} = & \\ & [(\text{Rework hours} * \text{Quality line rate}) + \text{scrap cost}] * \\ & (\text{Production volume of 2010} + \text{Production line of 2011}) \end{aligned} \quad (1-3)$$

Real cost per project

The real cost per project considers all related part numbers.

Real cost of each project =

$$\sum_1^n (\text{Production cost for next 2 years} + \text{Quality cost for next 2 years}) \quad (1-4)$$

n=number of specific parts involved with the project

1.1.2.2 Customer Opinion

The customer opinion is based on the shop floor investigation. The operators and the supervisors are consulted in order to determine the level of importance of each project.

The customers evaluated the projects in three levels “High importance, Medium importance and Low importance”, and three values were allocated for these three levels as 10, 5 and 1 respectively. These values were used in general formula in order to modify the cost and apply the customer opinion in prioritization as well.

1.1.2.3 Probability of Success

The probability of success is determined as the percentage of realization possibility. Estimation of this percentage is based on the engineering consult, previous experiences and available methods for development. The percentage varies per project.

1.2 Result

Based on the addressed procedure the projects were prioritized. Following eight projects were selected for further research and investment:

1. Quality improvement of the received tools used for producing turbine blades
2. Improvement the consistency of the fuel nozzles’ deburring results
3. Improvement the deburring of balancing ream holes and interior holes
4. Tool wear control during manufacturing process of the turbine blades
5. Quality improvement of the received tools used for producing diffusers
6. Improvement the deburring of the countersink firtree of the turbine disc
7. Quality improvement of the received tools used for producing fuel nozzles
8. Optimization of machining or polishing process to overcome hand polishing difficulties in fan blades

The highest costs of the projects were assigned to project 1 to 3. High probability of success (more than 50%) in addition to the fact that the customers exposed very high interest in the addressed projects, enlist them in the top of the prioritized projects.

One can find the summary of the results for the last five projects in

Table 1-1: Summarized prioritization results

Project		Real Cost	Customer Priority	Probability of Success
4	Tool wear control (turbine blades)	Very High	Very high	30%
5	Quality improvement of received tools (diffusers)	High	Very High	50%
6	Improvement the deburring of firtree (turbine disc)	High	Very High	25%
7	Quality improvement of received tools (fuel nozzle)	Very High	High	50%
8	Mismatch (fans)	High	High	60%

Among these projects, I chose to conduct my research on Improvement the consistency of the fuel nozzles' deburring results, which include manpower and manufacturing issues. The fuel nozzle parts are deburred manually though operators at this section face a repetitive manual action. Furthermore, the repetitive nature of the job decreases the precision of the manual process because the operator can easily lose the focus while working. On the other hand, the parts are very small with very tight tolerances and critical faces. This has extremely limited the manufacturing option to find solutions for parts with deburr, and the unit has the high amount of scrap in comparison to other manufacturing units within P&WC.

I decided to tackle this project not only due to the high technical and industrial importance but also due to the high academic value of addressing such a general issue that can make an important change in manufacturing though no need to say that the humane side of this project to provide a better working condition for the operators is priceless.

CHAPTER 2 PROBLEM DEFINITION AND APPROACH

Air-swirlers are part of hot section of aircraft engine, which their main purpose is to create airflow turbulence for optimal mixing of air and fuel as well as stabilizing the flames in combustion chamber. These critical small parts are made of heat resistant super alloys of nickel, which exhibit high toughness and are prone to strain hardening. The airflow turbulence is achieved by blowing the air through the inclined holes, which intersects specific profiled surface. Figure 2-1 represents a schematic of an air swirler.

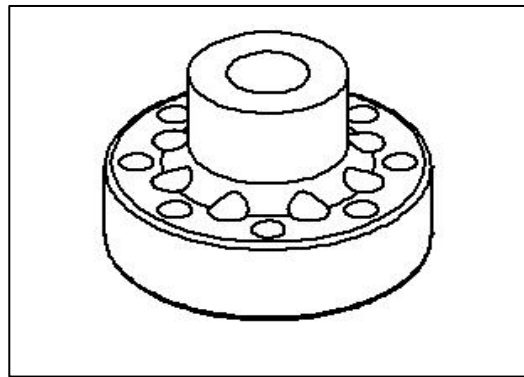

Figure 2-1: Schematic of an air swirler

During manufacturing process of these parts large raised material is produced on the edge of the holes due to the high toughness of nickel alloys. The raised material should be removed from the edge of the holes and edge should be treated somehow, it meet tight tolerance requirement of 0.003 to 0.015 inch break edge. Since the parts are under high thermal and fatigue loads, the break edge aims to decrease the micro cracks at the edge of the hole. Furthermore proper break edge can ameliorate the airflow of the part. The adjacent critical surface restricts the deburring action. The geometrical complexity of the parts and the variety of features restricts the parts to deburr by a one single deburring process. Thus the parts should be deburred in different sequences. Concerning all above the deburring process of air-swirlers is predominantly manual. Since these parts are inspected visually, the break edge is not measured after hand deburring.

The main issue of these critical parts is inconsistency of deburring results. The inconsistency of break edge on air-swirlers can be addressed to tree various definitions:

- **Profile inconsistency:** The break edge is not consistent along the edge of the hole. The edge profile becomes thicker and then turns thinner around the hole. Figure 2-2 shows both consistent and inconsistent edge profiles.

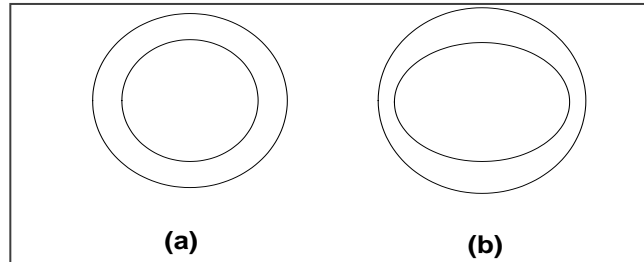

Figure 2-2: Schematic of consistent profile (a), and Inconsistent profile (b) around the hole

- **Break edge variation from hole to hole:** Similar holes of the part have different break edge size. The average break edge around each hole is different from others around the part. Figure 2-3 schematically explains the break edge variation from hole to hole.

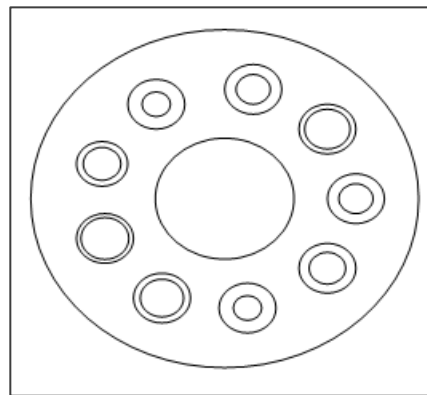

Figure 2-3: Break edge variation of holes around the part

- **Air flow variation from part to part:** An important purpose of the edge dressing of air-swirlers is amelioration of airflow. The break edge directly affects the airflow of the part. Thus with the inconsistent deburring results the airflow varies from part to part, although, it certainly remains in the acceptable range.

The inconsistency can be referred to two typical issues: inconsistent geometrical parameters of the burr, and unrobustness of the deburring process.

To tackle the inconsistency issue, literature review conducted on burrs on drilled holes and their type and formation. The survey continued on various deburring processes to find applicable ones.

The current deburring process was completely assessed. Moreover, the manufactured products were investigated to illustrate the current state of deburring results. Affecting parameters their weight factor were studied in different levels. With respect to the result of conducted experiments, different scenarios were designed to tackle the root causes. Some of the scenarios were selected to validate by complementary experiments considering the availability of equipment and project budget.

CHAPTER 3 BURRS IN DRILLED HOLES

Drilling is the most widely used process for producing holes through the manufacturing parts [13]. As a common issue, drilling, as well as other machining processes, produce undesired raised material on both entrance and exit edges. The raised material caused by plastic flow is defined as burr, which is necessary to be removed for critical and precise parts [11]. This chapter provides a comprehensive study on burr phenomenon, burr formation mechanism in drilling process, drilling burr classification, burr control in drilling process and burr measurement.

3.1 Burr phenomenon and characteristics

Burr in most dictionaries is defined as protruding, rough ridge raised on the a workpiece edge during manufacturing process. Ko [12] describes burr as unwanted raised material generated due to plastic flow during cutting and shearing operation. Gillespie [15, 20, 21] defines burr as “Plastically deformed material that is produced, because of machining or shearing, at workpiece edge”. In his definition any extended material beyond the intersection considered as a burr so the burr can place inside the intersection.

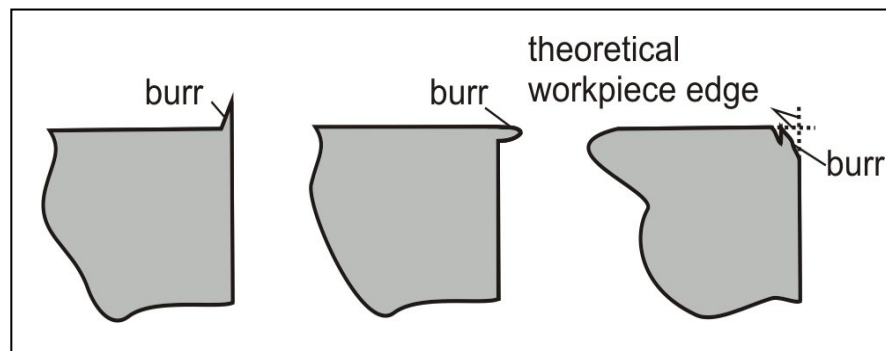

Figure 3-1: Burrs Inside and outside of theoretical intersection [21]

Burr can be characterized by various parameters such as geometry, type and mechanical properties. The difficulty of removing a burr is dependent to the burr characteristics[22].

The geometrical profile of the burr is described by Schäfer[23]. He explained the burr geometry as the following longitudinal and cross-sectional measurement categories.

- The burr root thickness: width of root of the burr measured in the cross-section.

- The burr height: the distance between the highest point of cross section and the ideal edge.
- Burr root radius: the radius of the circle positioned at burr root profile[23].

Other important properties of burr can be mentioned as

- Burr length: the length of the burr along the edge.
- Burr hardness: the harness of the burr measured at the root of the burr[15].

Figure 3-2 represents the burr geometry.

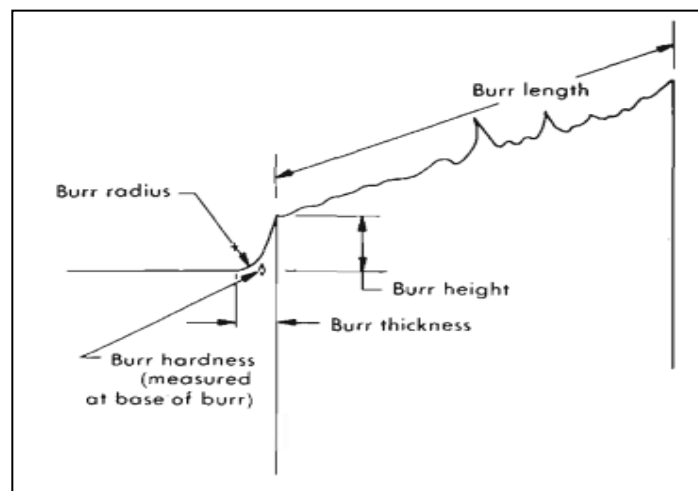

Figure 3-2: Burr geometry [22]

The burrs and other material projections such as flashes are produced by various physical mechanisms, which classifies them in six main groups. The first three groups of protrusions are formed by plastic deformation[15, 22].

- Poisson burr
Lateral deformation of the workpiece edge along the tool cutting edge due to compression produce Poisson burr. These burrs are relatively small. The deformation is depending on applied force, workpiece and tool material.
- Rollover burr

When the exiting cutting edge bends the chip instead of shearing it, rollover burr is produced. The length and thickness of rollover burr is depended to cutting conditions and plasticity of workpiece material.

- Tear burr

Tear burr is formed when the chip is torn instead of being sheared. These burrs can occur in most cutting processes [15, 22, 24]. One can find the schematic of Poisson, Rollover and Tear burrs in Figure 3-3.

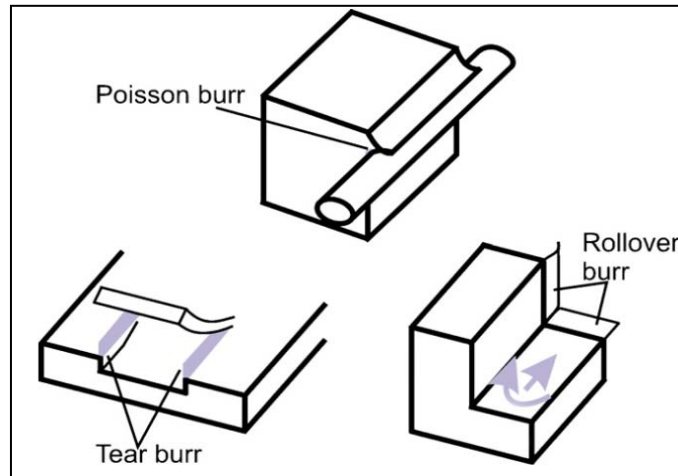

Figure 3-3: Schematic of burrs created by plastic deformation [11, 24]

- Recast bead

Recast material is produced by re-solidification of molten metal on the edge. This protrusion is mostly appears in processes which material is removed by thermal mechanisms such as electro discharge machining and laser machining [24].

- Cut-off burr

Cut-off projections are burr-like overhangs, which are formed by parting the workpiece from bar-stock before the tool completes the separation cut [11, 22, 24]

- Flash

Flashes occur due to the flow of material into the gap between two mold halves, in the absence of proper clamping pressure during casting [15].

Gillespie [16, 24] and Pekelharing [25] were the first researchers who described the mechanism of burr formation. Hashimura [26] proposed a model in which the formation of burr is influenced by mechanical properties of the workpiece material as well as the geometrical profile

of both the tool and the workpiece. He describes the burr formation process in eight stages, which can be observed schematically in Figure 3-4. Since the crack propagation mechanism in ductile and brittle materials is different, the stages are described separately after crack initiation. Stage 1 describes the shear zone and chip flow in cutting process. Pre-initiation is the next stage in which, the workpiece edge starts to elastically deform or bend. Burr initiation described in stage 3 as a plastic deformation zone forms on the workpiece edge. This phenomenon is concurred with development of primary shear zone and plastic deformation zone around it. In stage 4, called pivoting, a considerable deformation occurs at workpiece edge, which can be visually observed. The burr is developed in stage 5 as a negative shear zone forms and the deformation zone enlarges to join the primary shear zone.

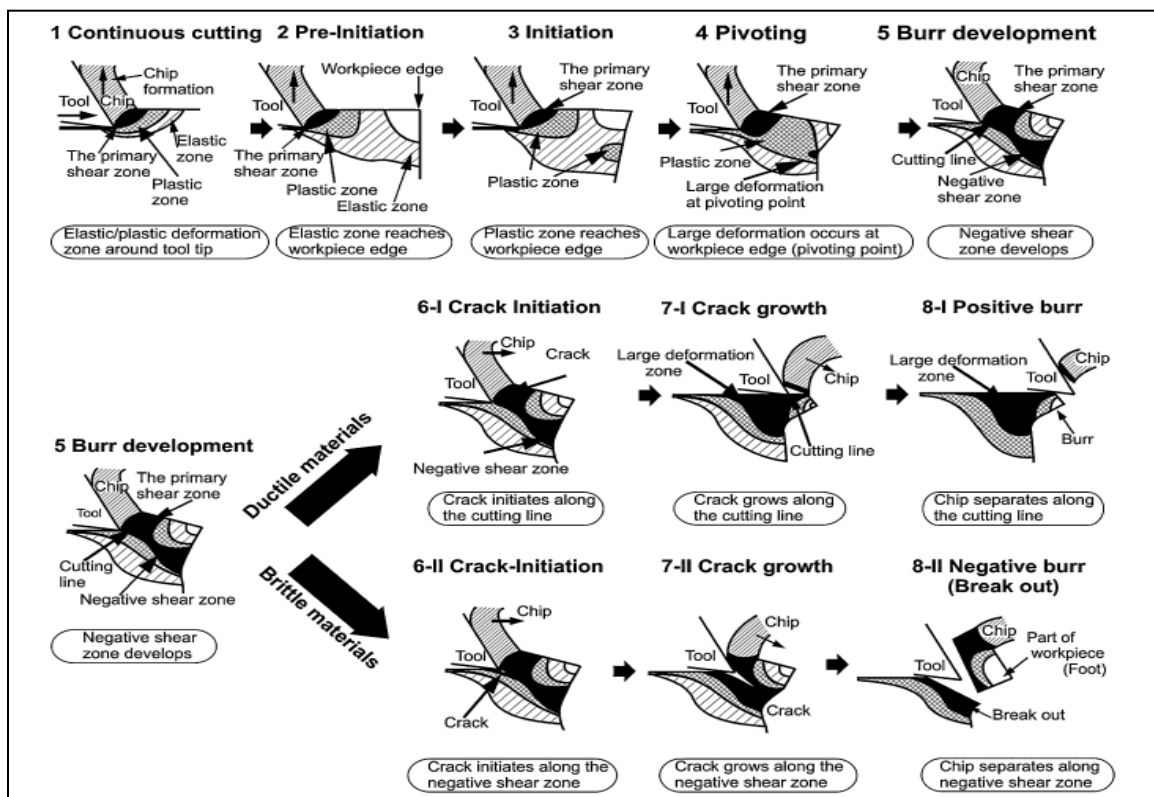

Figure 3-4: Schematic of burr formation in ductile and brittle material [26]

From the stage 5 on, the burr formation mechanism is defined based on material behavior. Stage 6 explains the crack initiation, which starts along the cutting line for ductile material (Stage 6-I). The ductile materials have larger fracture toughness. Thus, the crack initiates in primary shear zone and develops along the cutting line in stage 7-I. As the tool moves toward the workpiece

edge, the crack is expanded and the workpiece is deformed along the cutting line. In stage 8-I the crack separates the chip and leaves the deformed material as a positive burr on the workpiece edge.

In brittle material the crack propagation mechanism contrasts as the crack initiates in negative shear zone in stage 6-II. The crack starts at the tool tip and then it propagates along the negative shear zone. In stage 7-II the crack enlarges toward the pivoting point. Though, no large deformation is induced on the workpiece edge. In final stage (8-II), the crack parts the chip plus the material above the crack propagation line. This leads to formation of a fractured edge called negative burr.

3.2 Burr formation in drilling process

Since the main objective of this study is deburring of drilled holes, the literature survey is continued focusing on drilling burr formation.

In drilling operation, the burr forms on both entrance and exit surface of the part. Since the burr on the exit surface is considerably larger than the entrance burr most of drilling burr formation studies are focused on the exit burr [14]. The entrance burrs occur due to compression of material near the drill which leads to material flow along the tool edge (Poisson effect). Whereas the exit burr is unsheared chip extended off the edge[14, 15].

Gillespie[16] is among the first researchers who offered a basic model for burr formation in drilling process. He also investigated the effect of tool geometry, cutting conditions and material properties over wide range of experiment condition.

Stein [17] proposed a simple burr formation model in Titanium alloys. An inclusive burr formation mechanism is proposed by Kim [18] and Min [19] based on the study of drilling burr formation for low alloy steel AISI 4118 and stainless steel AISI 304. Kim [18] classified the burrs in three types : Uniform, Transient and crown burrs. The basis of the classification is burr shape. The burr shape is of concern because the deburring cost is dependent upon the size of the burr. He detected all the three types of burr in drilling AISI4118 and two types of burr in drilling AISI 304L, which one can find in Figure 3-5 and Figure 3-6 respectively.

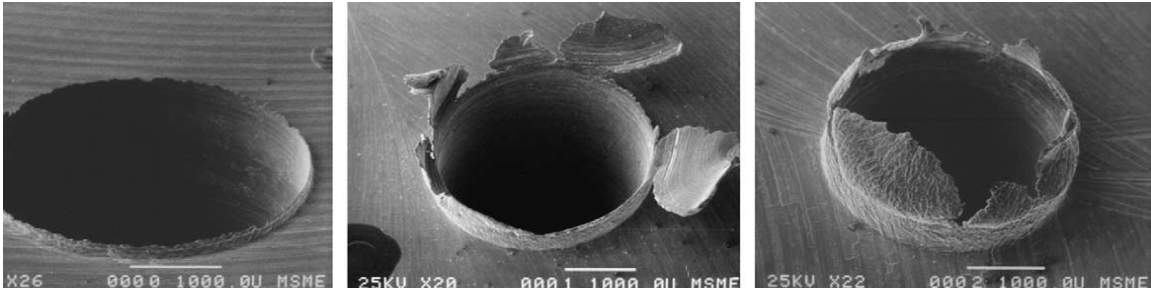

Figure 3-5: Three types of drilling burr of AISI 4118 (a) Uniform burr with a drill cap; (b) transient burr; (c) crown burr [18]

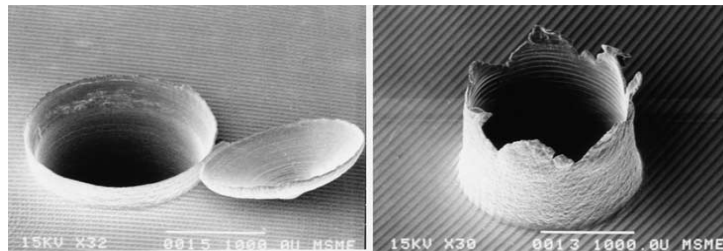

Figure 3-6: Two types of drilling burr of AISI 304L. (a) Uniform burr with drill cap; (b) crown burr [18]

Under certain cutting conditions, in both materials, a slight and thin burr with unvarying profile is formed around the edge of the hole, called the uniform burr. The uniform burr is observed with or without an attached drill cap. Another type of the burr, which is formed in both materials, is crown burr. The crown burr is larger than the uniform burr and it has variable profile around the hole periphery. In drilling AISI 4118 an additional type of burr is formed which is called the transient burr. This burr is formed in the transient stage as the burr tends to transform from uniform to crown burr. The formation of transient burr can be addressed to material properties such as strain hardening rate and toughness [18].

Afterward the burr formation mechanism is proposed based on the classification [18, 19]. Figure 3-7 demonstrate the mechanism of burr formation for the three types of the burr.

As the drill approaches the exterior face of the workpiece, a plastic deformation zone is formed under chisel edge because the chisel edge does not have a cutting edge. The deformed material under the chisel edge reaches the exit surface of the workpiece, while the material in vicinity of chisel edge is cut off by the cutting edge. As the plastic zone is diluted, the cutting action starts to transform to bending action at the center of the drill.. The plastic deformation zone expands from the center to the edge with advancement of the tool. The size of the plastic deformation zone is

mostly dependent to the thrust force of the drill. When the plastic deformation zone is thin enough, the fracture starts at the end of cutting edge forming a drill cap. The remaining material is bent along with the drill and forms thin, small height burr with a uniform shape around the edge (see Figure 3-8). Larger uniform burrs can be formed if the initial fracture occurs near the center of the drill. The primary fracture produce a secondary cap attached to the main drill cap. Then the secondary fracture takes place at the end of cutting edge and creates drill cap. Larger amount of material is pushed out ahead in this situation to create the uniform burr [19].

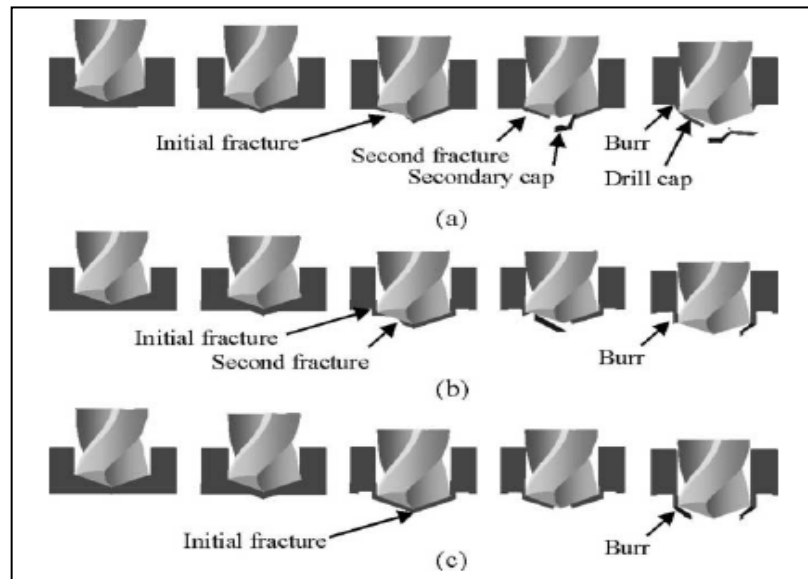

Figure 3-7: Formation of different burr types during drilling [14, 19]

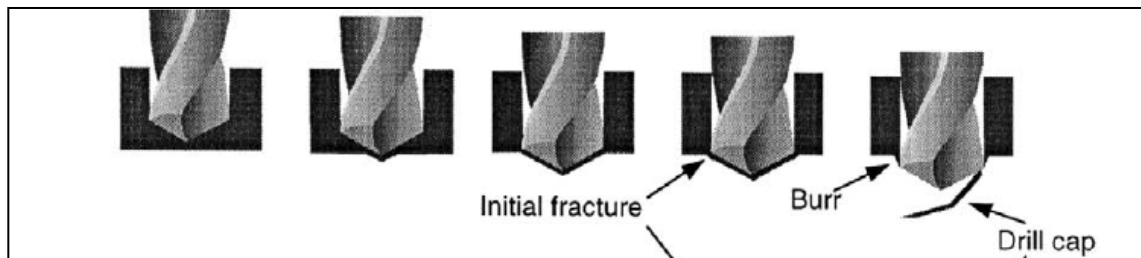

Figure 3-8: Formation of uniform burr [18, 19]

Increasing the thrust force induces the plastic deformation earlier in the process. Thus thicker layer of material under chisel edge experiences the plastic deformation. This increases the maximum strain at the center region of the plastic zone. Subsequently the area becomes more brittle due to strain hardening and the initial fracture occurs at the drill center creating the crown burr with large and irregular profile around the hole.

Transient burr, which is observed in drilling AISI 4118, forms in the transient stage between the uniform and the crown burr. If the initial and second fractures occur simultaneously near the end of cutting edge and center of the drill, the transient burr is formed. This burr has larger uniform section with attached ununiform material around the hole [19].

CHAPTER 4 BURR REMOVAL AND DEBURRING PROCESSES

Deburring and edge finishing is an important step in manufacturing of precise and high quality parts. The key consideration toward selecting a reliable and cost effective deburring process is to identify the edge requirements. Although defining quality requirement is necessary, the process selection needs an overview of various processes and their capabilities. This chapter address the edge quality definitions as well as the deburring processes, which were selected based on tolerance, geometry, burr characteristics and base material of the target workpieces of this study.

4.1 Edge requirements

Burr definition as well as its classification criteria varies industry-by-industry and even company-by-company. Based on production needs and design requirements companies usually develop in-house standards for edge qualifications. While a “burr free” edge could be defined in some standards as no detection of loose material with aided vision, in some others it is defined as the edge condition which does not cause problems in either the next stages of assembly or its working performance [27].

Fortunately, several standards have been developed to classify required edge condition, and to provide appropriate drawing notation for engineers. One of them, which was developed by Gillespie [15] suggests seven steps of edge quality needed for the corresponding application and manufacturing processes. This standard will be explained with more detail in following. In contrast to this standard, which is based on verbal description of edge quality, the standard of Schäfer [23] provides a quantitative measure based on preferred values of edge condition. The values were chosen such that the number of classes was kept to nine. Figure 4-1 shows the parameters of burr quality in a coordinate system.

Other standards for evaluating edge quality have been developed [28, 29]; the former one defines acceptable burr parameters like its height based on code tables and work instructions in various case studies. The later developed by Kato divided quantitatively the edge quality into two critical and non-critical functionality conditions, each of which was subdivided into five and three quality states, respectively. Among the previously mentioned standard, which might be applicable in various industries, other standards like Berger’s [30], which covers many

applications in automotive industries, are more specific to the requirements of their corresponding industries.

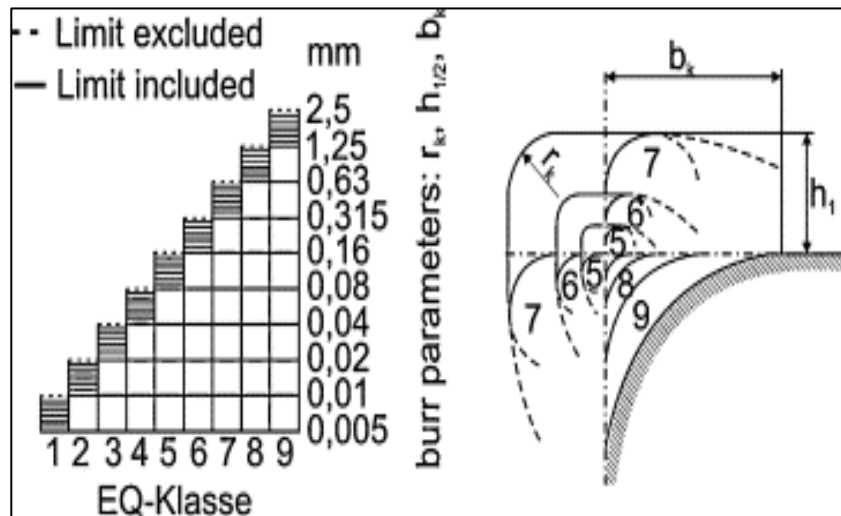

Figure 4-1: Edge quality classes [23]

Based on [15] seven levels of required edge quality are defined. 1) *Deburring is not required*; although burr size might be larger than its limit, the producer leaves the burr as produced by the previous process. 2) *Remove sharp edges*; at this level edges are removed so to prevent them cutting operator skin, wires, etc. Important to note that burr size should be small enough such that part size does not exceed drawing limits. 3) *Remove all visible burrs*; all burrs that can be seen with unaided vision, and those which violate drawing limits should be removed. 4) *Remove all burrs visible at \times magnification*; it implies that all burrs detectable by any optic methods and lighting form with the specified magnification should be removed. 5) *Break edges \times \times mm minimum*; which indicates the chamfer size as the maximum limit that no material should exceed. 6) *Round edges \times to \times mm radius*, in this level edge should be curved with maximum size specified. In contrast to level 5 in which the edge could be chamfered, blunted, etc, in level 6 curvature of the edge is important that chamfer is not acceptable. 7) *Do not deburr*; deburring is prohibited. While in level 1 deburring is an arbitrary process that is based on manufacturing, and economical requirements, in level 7 deburring is not allowed.

4.2 Hand deburring

Among 109 different deburring processes hand deburring is still the most widely used one. Although it may result in inconsistent products it is still desirable mostly owing to its flexibility

and versatility and also because it involves minimum floor space and investments. During hand deburring the operator could employ his creativity in improving the process, while he could choose the best approach and tool based on his experience.

Based on Gillespie [20] hand deburring is a cost effective option when:

- 1- Reaching and removing the burrs with other processes is difficult due to the geometry of the part.
- 2- The number of runs is of concern. For example when there are time limitations for few parts.
- 3- There are limitations for other processes. For example when the part size does not fit the deburring machine or when the part require precised deburring process which do not change the part dimensions or produces residual stress. In this case hand deburring process is the best choice.
- 4- Within a cycle hand deburring should be performed simultaneously to the other machining processes.
- 5- Process qualification is of concern.

In order to increase the effectiveness of the hand deburring process, certain considerations should be taken into account. Cost of the operation, edge requirements, available equipments, size of the burr and the accessibilities are listed as the fundamental factors of a manual deburring process, which should be considered perfectly in order to achieve an effective process. Furthermore choosing the appropriate deburring tools is essential in order to aim this goal. 23 tools which are introduced as effective tools by Gillespie [20] is shown in Table 4-1.

Table 4-1: Manual Deburring tools [20]

<ol style="list-style-type: none"> 1. Abrasive-filled products <ol style="list-style-type: none"> a. Cork products (bullets, ball nose, cylinders) b. Cotton products (cylinders, balls, bars) c. Nylon synthetic products d. Rubber products (bullets, cylinders, flat bars, disks, cups, dental bullets) 2. Abrasive wood tools 3. Ballizing tools 4. Bonded abrasive tools (abrasive paper products—disks, rolls, sheets, cord) 5. Brushes (wheel, end and cup, tube, cross hole, side action) 6. Burs, bur balls, rotary files 7. Countersinks 8. Drills and reamers 9. Felt bobs (disks, bullets, cylinders) 10. Files (large, miniature, round, half-round, triangular, curved, bent) 11. Hand-operated mechanized machines 12. Hand stones (bars, triangles, cones, points) 13. Hot wire tools for thermoplastic parts 14. Knives (triangular, oval, special shapes, scalpel blades) 15. Lapping compounds 16. Mandrels for tools 17. Motorized tools (bench motors, air motors, dental tools, belt sanders, reciprocating files, jitterbug sanders) 18. Mounted points (balls, disks, cylinders, cones, special shapes) 19. Peening tools (ball peening, blade peening) 20. Picks 21. Pin vises (dog nose, collet) 22. Scrapers 23. Miscellaneous tools (back-side cutters, special designs, vacuum probes)

4.3 Abrasive jet deburring

Abrasive jet machining (AJM) as an effective non-conventional machining method can be applied to various difficult-to-machine materials, providing acceptable surface and close tolerance. Wide range of operations such as deburring, polishing, cutting, drilling etc., can be performed using the AJM process [31]. AJM as a deburring process does not apply mechanical forces. The part dimension does not change except the smooth radius which is created on deburred edge [32].

The abrasive jet machining material removal is obtained by directing accelerated abrasive particles on to the material surface. The fine abrasive particles are mixed with compressed air to provide a high velocity abrasive jet through a nozzle. The momentum of accelerated abrasive

particles in collision with target surface causes impingement erosion thus the material is removed from the surface [32-34].

These are various parameters that affect the generation of edge radius such as nozzle diameter, stand-off distance which is represented as the distance between the nozzle and the target surface, impingement angle, grain size, flow rate and jet height. Figure 1 demonstrates the effecting parameters of abrasive jet deburring process. Among the effecting parameters stand-off distance and nozzle diameter play a significant role in generation of edge radius[34].

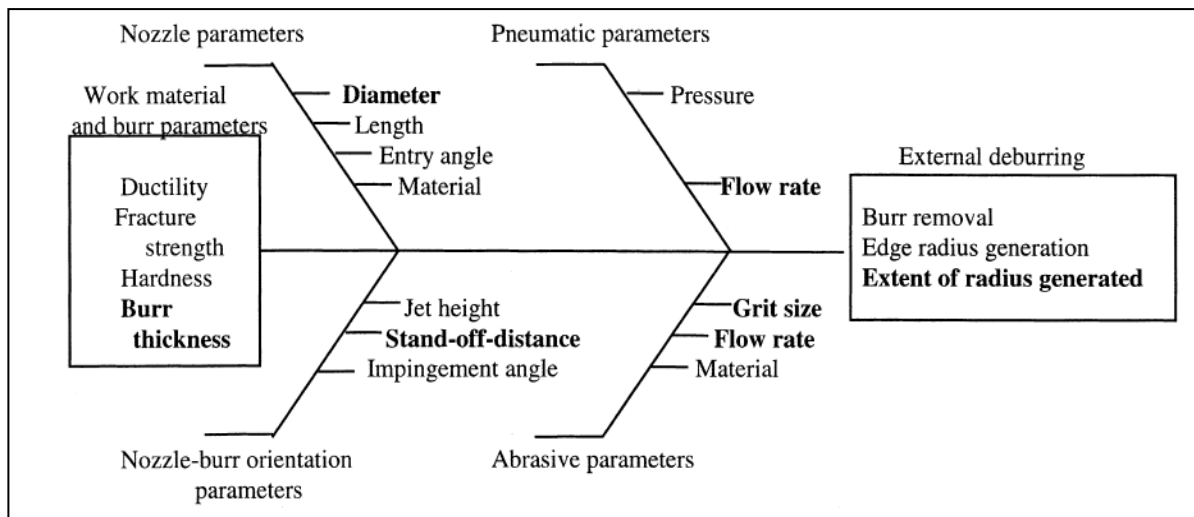

Figure 4-2 : Effecting parameters of abrasive jet deburring process [34]

The AJM process can be implemented by abrasive jet machine or by an abrasive jet handpiece. Figure 2 represents a schematic layout of abrasive jet machine.

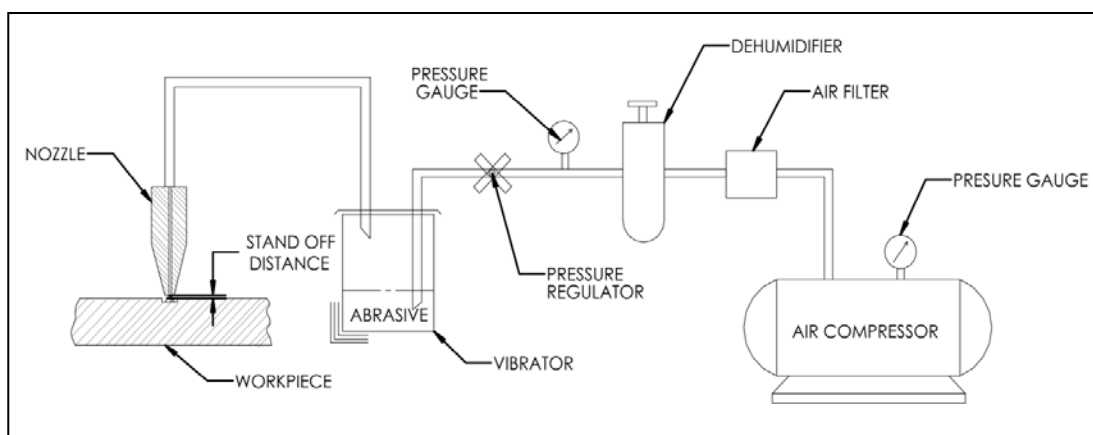

Figure 4-3: Schematic layout of abrasive jet machine [35]

4.4 Electropolish and Burlytic Deburring

Electropolish deburring process employs an electrolyte solution to remove the metal from the target edge and surface[15]. The main concept of the process is based on concentration of electrolytic dissolution on the workpiece projections called anodic dissolution [36, 37]. Cathode rods and anode racks are hanged in the solution, making a circuit. The parts are connected to the anodic rack and cathodes are positioned near to workpiece[15, 36]. Low-voltage direct current, which is conducted through the electrolyte, polarizes the surface of the metal workpiece, creating a metal ion film. The metal ions diffuse through the film and change to metallic salts. Figure 3 shows a schematic electropolish deburring tank.

The ion film is thinner on surface and edge projections thus the current density is higher due to the lower electrical resistance. This phenomenon leads to preferential material removal on ridges and surface irregularities[15, 37]. The material on soaked surface is removed as well as raised material so the electropolished workpiece has bright and smooth surface[15]. Hardness, toughness and other physical and chemical properties of the material does not affect the metal dissolution rate. Electrolyte concentration, inter-electrode gap thickness and electrical current voltage can be represented as the dominant machining parameters. The non-contact characteristic of electrochemical process eliminates all mechanical and thermal stress. Consequently the machined part does not feature any heat affected zone and residual stresses [36, 37].

The electropolish deburring process is appropriate for all conductive metals such as stainless steel, high nickel alloys, nickel silver, aluminum, brass, copper and zinc. Burrs with 0.0005 to 0.001 inch thickness can be removed with this process while the height of the burr does not affect the process. The edge stays sharp after deburring. Due to the low cycle time of the process, numerous processed parts per each work cycle and the fact that the process does not need any special tooling, electropolish can be employed for high-production parts. The process does not remove large and thick burrs thus it is applicable for precision parts with thin raised materials on the edge [15].

There are various types of solutions such as acid-based solutions, alkaline, cyanide, and metal electrolytes. The solution selection depends on the target alloy. Previously acid-based solutions

were the most common but at present the most widely used deburring solutions are proprietary solutions.[15]

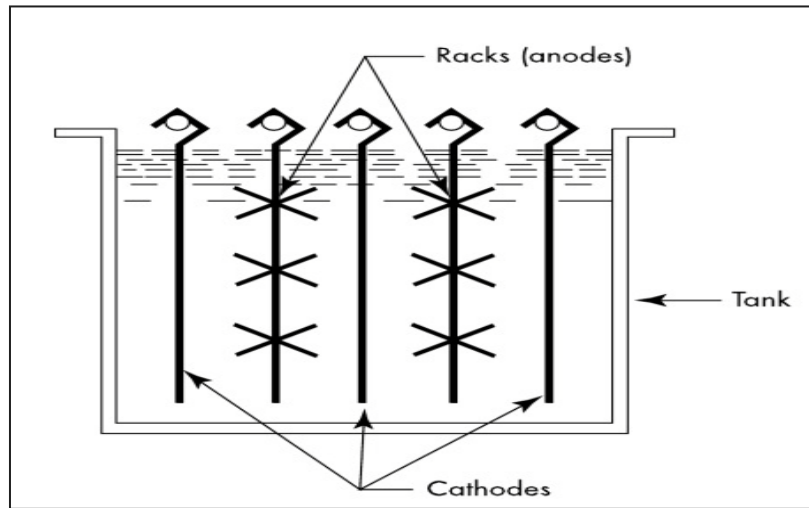

Figure 4-4: Electropolish deburring tank.(courtesy Electro Glo Company)[15]

Burlytic process is an electrochemical process, which has the same process principles as electropolish. Burlyte, a non-aqueous electrolyte with high electrical resistance properties, is the advantage that makes the Burlytic deburring different from other electrochemical processes. The electrolyte is available in two types: Burlyte A or Burlyte C. Both Types have near-neutral PH and they are non-fuming, odorless, and quite safe to handle. The process owes its inexpensiveness and simple tooling requirement to the edge-seeking nature of the electrolyte. However, at very difficult-to-access edges, such as narrow intersecting holes, tooling becomes more complex. Although it should be mentioned that, cathode distance does not affect the process quality [38].

Burlyte electrolyte acts selective. The selective electrolyte idea is based on the theory of the mechanism of electrical current transportation.

Ionic movement in electrolytes can be addressed to three mechanisms:

- Diffusion: Ions transport due to concentration gradient.
- Convection: Ions transport through mechanical flow of electrolyte.
- Migration: Ions transport because of electrical potential gradients.

In low viscosity solutions with high conductivity, such as aqueous electrolytes, ion diffusion is the dominant transportation mode. In contrast, in Burlyte electrolyte, ion transportation via convection and diffusion is very slow due to the low dielectric constant compared with aqueous-based electrolytes and high viscosity respectively. Thus the dominant transportation mechanism of ions in Burlyte is migration. The electrical field is stronger on burrs, so, ions move faster[38].

The process is appropriate for high-precision small parts as well as large and less delicate parts. Since the process is very quick and the electrolyte acts selective the burr on the edge is removed but the surface remains unaffected. However surface finish improves due to the fact that microroughnesses of the surface become smooth[38].

4.5 Cryogenic Deburring (Via Liquid Nitrogen)

Cryogenic deburring uses cryogenic temperature (accomplished by using liquid nitrogen) to make the thin raised material fragile. The embrittled burr is removed by blasting solid rubber particles or by the use of tumbler or vibratory machine[39, 40]. Since the material experiences very low temperature during the process, the time set up is extremely important due to avoid damaging the workpiece structure. As the time exceeds a certain limit the part embrittles as well as the raised material, which is not preferred. Thus the burr should be thin enough to freeze quickly before the part reaches its embrittlement temperature. Since the parts core should not meet cryogenic temperature, the preferable materials for the process are the materials with low thermal conductivity such as rubbers, plastics, zinc and aluminum alloys [39]. Recently due to new technology development the process is applicable for many types of engineering materials, even high grades of stainless steel and various super alloys[41].

The process can be very precise depending on the media or blast particles. No change in part dimension is reported in previous deeds and investigations. Burrs are completely removed without any dust or residue remaining on the part. Process, itself, is repeatable and reliable due to the fact that it benefits automated system. Since the process variables such as temperature, time, tumble speed, media velocity, and media size can be set up on machine, the process benefits high flexibility through combination of parameters depend on the shape, size, and base material of the workpiece[39, 40, 42].

4.6 Thermal Energy Deburring

Since 1960, Thermal Energy Method (TEM), have been commercially practiced as an unconventional deburring and finishing process. The process burns away burrs and flash using combustion. The combustion process provides required energy for processing [43]. The intense heat generated through combusting fuel gas and oxygen vaporizes material projection on both inner and outer edges and surfaces [15]. The combustion occurs only when all the three crucial items including fuel, oxygen, and heat are present. The cycle will be incomplete if one of the three is eliminated during the process. Figure 4-5 shows TEM deburring process.

The target workpiece is placed on an index table in a sealed under pressure chamber. The pressurized gas mixture around the part ignites through high-voltage electrical spark and creates approximately 3000 deg. Celsius temperature within 2-3 micro seconds [15, 43]. Material projections root restrict the heat flow due to their small thickness. Thus the heat is accumulated in the burr instead of propagation within workpiece body and leads to automatic ignition of the burr [43]. As the flame gets to surface of the part, it is extinguished. Body of the workpiece is not burned because disparate the burrs they do not have high surface to mass ratio. During the process, raised material combines with oxygen, creating oxide of the parts parent material, which in most cases needs to be removed [15, 43].

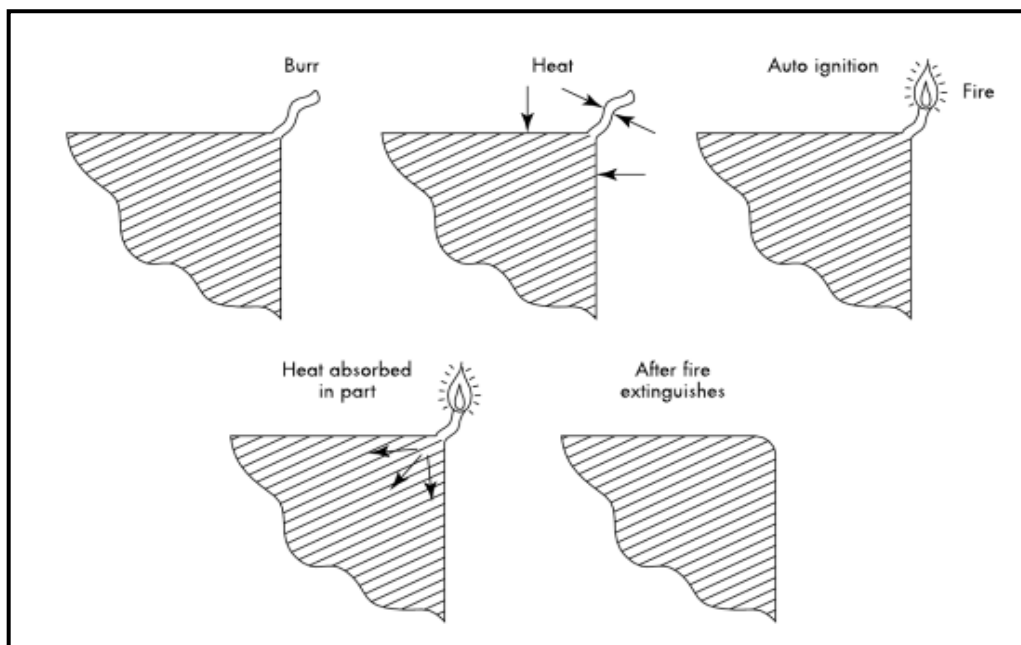

Figure 4-5: TEM deburring process[43]

The process is flexible since the two main variables, gas mixture and pressure chamber, regulate the amount of generated heat and heat wave intensity and lasting time. These main variables can be selected somehow, not only large or small burrs are removed from the workpiece, but also appropriate break edge is provided on the part [43]. The richer the mixture and the higher the pressure, the larger burr is removed [15, 43].

Significant improvement is observed in the process when the gas is used as the deburring media. Employing the gas is beneficial in comparison to other deburring processes in which the small abrasive particles are used as deburring media because, the gas can enclose confined areas, which abrasive particles are not able to reach[44-46] .

TEM is an appropriate process when high production volume of parts is of concern. The process can be employed to remove thin burrs and flash from parts for wide range of geometry, particularly for internal intersecting holes and external edges with critical adjacent surface. The process is applicable for all types of metals and alloys, although some of them are more difficult to be treated. The best performance of the process is observed through deburring metals with medium thermal conductivity. The process can affect material structure and cause imbrittleness, phase transformation or carbon deposition at grain boundaries [15, 43, 47]. For material with low heat resistant and high thermal conductivity factor, the heat cannot be accumulated in burrs so little or no deburring action is provided [47].

4.7 Magnetic Abrasive Deburring

Magnetic abrasive deburring is a mechanical burr removal process, which benefits the presence of magnetic field to remove the unwanted raised material from the workpiece[48]. Magnetic field is employed in order to provide effective control of the deburring process, which makes the process capable of deburring advanced engineering material and difficult to finish alloys[49]. Furthermore the process can produce round edge with desired radius[50]. The micro-cutting force created by movement of hard abrasive grains is controlled by intensity of magnetic field. This prevents the surface damages generated by excessive penetration of the abrasive particles into the workpiece surface and, provides high surface finish [49].

Various machines and abrasive brushes designed to satisfy the quality requirement of different part geometries. The shape and the size of the particle, the shape and the place of magnetic

inductor, vibration mode of magnetic field, magnetic field density have significant effect on edge quality and surface roughness[48, 49, 51-53]. However the concept of controlling abrasive particles via magnetic field is not limited to magnetic brushes. In various mass finishing processes the concept employed in order to reach difficult-to-finish areas without getting the abrasive media stuck in the fine unreachable areas. In Figure 4-6 one can find the Schematic of magnetic abrasive barrel. The magnetic inducer can be rotary or oscillating. As the polarity changes, the magnetic pins spin or vibrate. Through the moving of the media, the tiny pins shot the workpiece with the induced magnetic force which, removes the edge projections[39, 54]. However the process will be more effective by tumbling or turning the parts against the moving media[39]. More complex geometries can be deburred with the process compared to conventional medias. Moreover, the short cycle time of the process prevents part from losing dimension requirement and makes it cost effective [54, 55].

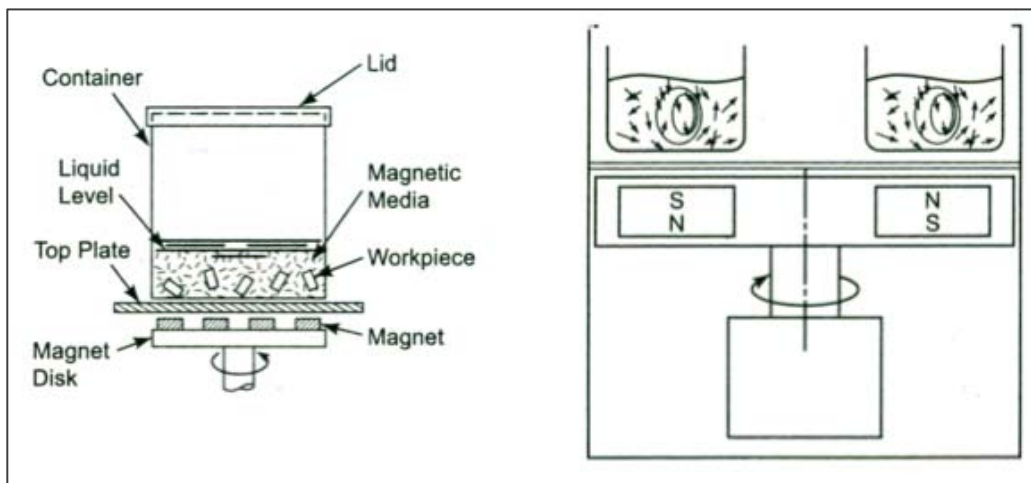

Figure 4-6: Schematic of magnetic abrasive barrel finishing [39]

4.8 Laser Deburring

Application of lasers in deburring process goes back to 1978 [56]. Numerous applications have been announced. However, no remarkable achievement in applying lasers for deburring is reported yet. Illinois Institute of Technology Research Institute in Chicago in the 1980s conducted the research on applying lasers in deburring process for the first time. However the results were not satisfactory. Generation of a heat-affected zone is the limiting point in applying this method for many operations [57].

However numerous advantages of laser deburring such as its short process time, flexibility, preciseness, ability to pursue the profile edges and the fact that it is a noncontact process, still serve it as an option in deburring certain materials [57].

In general lasers are categorized as continuous wave (CW) and pulse systems. Continuous wave systems produce (emit) continuous waves, whereas pulse systems perform through discrete pulses. Pulsed lasers are themselves broken down to long and short pulse systems [57].

The best example for laser deburring can be mentioned as its usage in Injection nozzles for ink jet printing [58]. The problem was the tardiness of the process when applying a single laser for deflashing and deburring the holes, and on the other hand the high cost of applying lasers when performing parallel process.

Nunobiki [59] successfully laser deburred 304 stainless steel. Lee [60-62] applied laser deburring on low carbon and stainless steels. They found laser deburring process more effective for producing a constant chamfer. This was attributed to the non-sensitivity of the process to the variation of burr size or tool force, owing to the noncontact nature of the lasers.

CHAPTER 5 METHODOLOGY

The main objective of this study is improving the consistency of deburring results of the air-swirlers. To aim this goal, a comprehensive study of current state of these parts, their manufacturing, and their deburring process is necessary. The investigation forms an inclusive idea about the inconsistency of deburring results, analyzes root cause of the issue, and provides us with a basis of comparison, which can be used further. An experimental survey has been conducted on the actual production parts at shop floor. The experiments design based on Design Of Experiments methods [63-65], which included root cause analysis to find the affecting parameter as well as their weight factor and interactions. Afterwards the second series of experiments have been planned and conducted on the parts to investigate the practical feasibility of the alternative processes to improve the consistency. In this chapter one can find the detailed explanation of the above procedure.

5.1 Investigation of current state of the parts

The current manufactured air-swirlers were investigated to clarify the state of the inconsistency, the root cause of the phenomenon, affecting parameters, and the weight factor of each parameter. This essential investigation aims better understanding of current process as well as facilitation of selecting next step to improve the process consistency. Thus, based on Design Of Experiment principles [63-65], the experiments were planned, designed, and conducted. Four part numbers were investigated during the experiments. The four part numbers are identified as the part A, B, C, and D.

Part A is the most difficult-to-handle due to its geometrical complexity and size, which leads to more sever burrs. Part B and C are smaller and they have major geometrical similarities such as equal edge requirements and almost equal hole size. Although a small difference in their manufacturing process makes their burr properties different. Part D is the easiest-to-handle due to its simple geometry and modified manufacturing process, which leads to slight burrs around the accessible holes.

5.1.1 Planning the experiments

Planning the experiments is the first phase of each experimental study. In this stage the experiment team members, objectives, root causes, measurement method, independent variables, and experimental strategy are illustrated.

Forming the experimentation team

In order to conduct experiments, first step is to define people who are involved with the experiments, have impact on the experiments or their support is crucial for the experiments. This can build a strong experiment team so the tests will be run effectively, on schedule and as fast and precise as possible. Team members were selected based on their contributions as follow.

Operators

Operators were involved in the tests due to their specialty in working with particular machines and devices.

Machine center operators were helpful for taking samples from production line. They have data concerning the tool life for each sample part and machine set up. From their experience in working with the machine center, they also have good knowledge about the technical problems during production that may cause various defects on the parts.

Inspectors

Inspectors are considered as reliable sources of difficult to find data about workpiece issues. They can provide us with the information about all types of defects, especially when the issue is not leading to rework or scrap the part.

Managers

Although managers are not directly involved in the experiments, they are the most important supporters of the project. The experiment process involves many people and needs their collaborations. Thus the support of management is beneficial in terms of collaborations between direct participants. On the other hand, management is the financial supporter of the experiments.

Manufacturing supervisor

The experiments are performed on the active parts, which are under production. To collect the samples and scheduling the tests on a production line, contribution and support of the line supervisor is critical.

Planners

Planners are schedulers of the production parts, so they are part of the team for preparing the timetable. They are also the people who can exactly clarify the restrictions of taking samples regarding the number of samples and delivery date of the products.

Process engineers of shop floor

Process engineer has comprehensive knowledge about the manufacturing process and furthermore he is the most important link between the experiment team and the shop floor people, especially those who work in production line. Process engineer is the quickest link to get access to set up parts and scrap parts.

5.1.1.1 Process Flow Diagram

In order to perform root cause analysis and define effecting parameters, an inclusive idea about the manufacturing process and production sequences is necessary.

Purchased raw material is delivered from the stores. The delivered material is inspected to make sure that the supported material as specified on the part drawings. The material acceptance stamps are checked as well. Passing the inspection raw material goes to heat treatment in order to uniform the hardness repartition. Then the material is inspected visually. Hardness and optical roughness test are also conducted before sending the material to the machine center.

The bar stock goes to the machine center to be manufactured as part specification. Main operations include spot facing, center drilling, drilling (small holes), and end milling respectively. The manual deburring process for various air-swirlers is approximately the same. There are negligible differences in tool utilization but the sequence of the sub-operations does not change per part. In bench deburring operation, first, the part is mounted to spring collet. Then a grinding wheel is applied to the part in order to remove large burrs. Then a file round needle and a stone

round tool are manually applied to each hole to create the primary break edge. Finally the part is polished via buff machine and through this operation the break edge is smoothed and enlarged.

One can find the process flow diagram in Figure 5-1 in order to have a better understanding of the manufacturing steps. The part flow diagram demonstrates each manufacturing operation with its sub-operations by sequence.

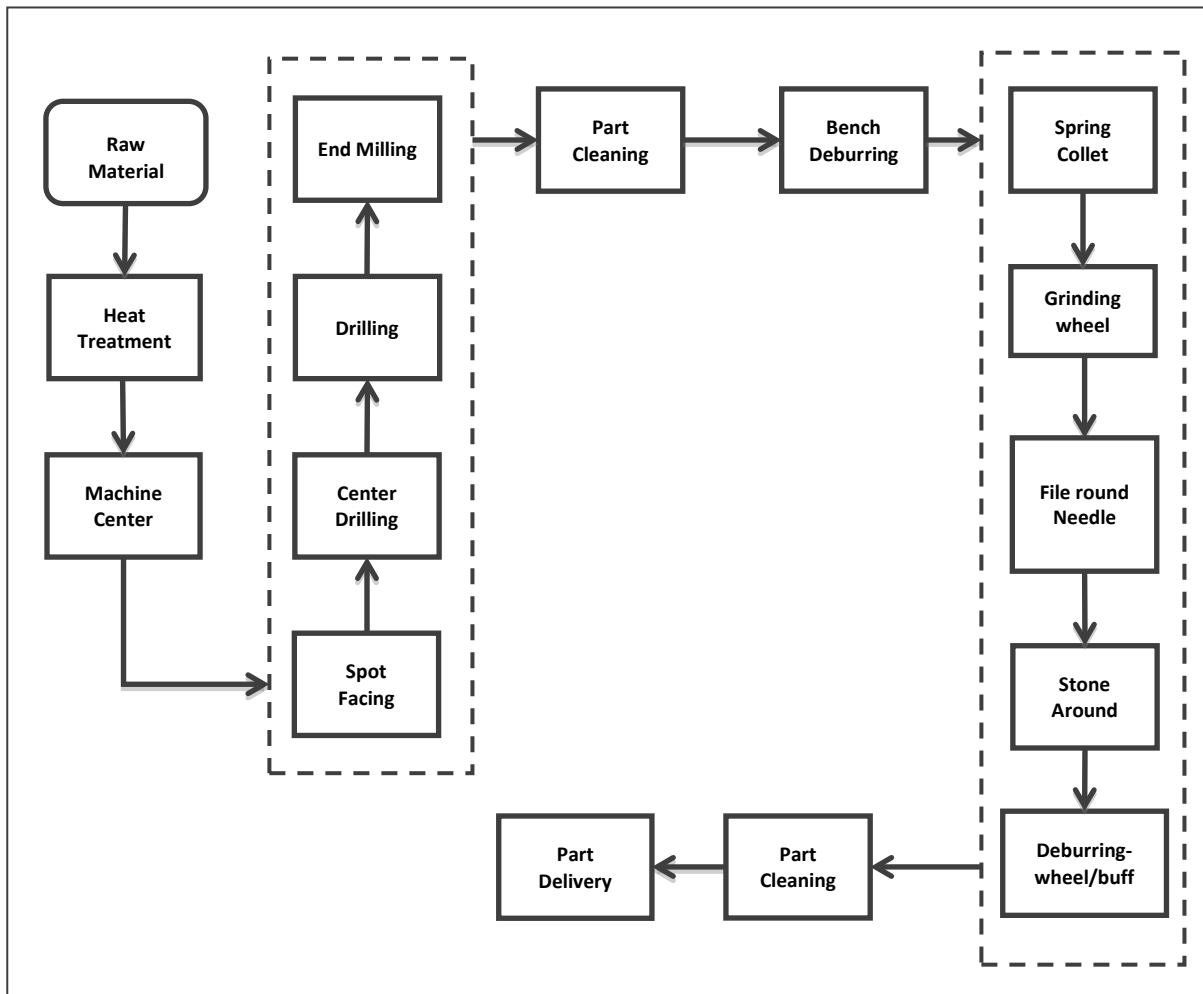

Figure 5-1: Process flow diagram

5.1.1.2 Fault Tree and Root Cause Analysis

Fault tree analysis is an important step to identify the possible root causes of a phenomenon. Root causes analysis aims to verify the process parameters. The main undesired event is placed on top of the tree and faults are hierarchically connected to the main event via appropriate logical gate.

The causes are divided to sub-causes until the branch reaches a basic event, which is a possible root cause [66].

In this investigation, the undesired event is inconsistency of break edge. The inconsistency happens when, the process, which creates the break edge, is inconsistent, or the input of the edge dressing process is inconsistent. Thus two main reasons could be named:

- Inconsistency of burr geometry
- Inconsistency of deburring operation

One can find the fault tree of the unwanted occurrence of inconsistent break edge in Figure 5-2. A detailed description of the fault tree and root cause analysis follows.

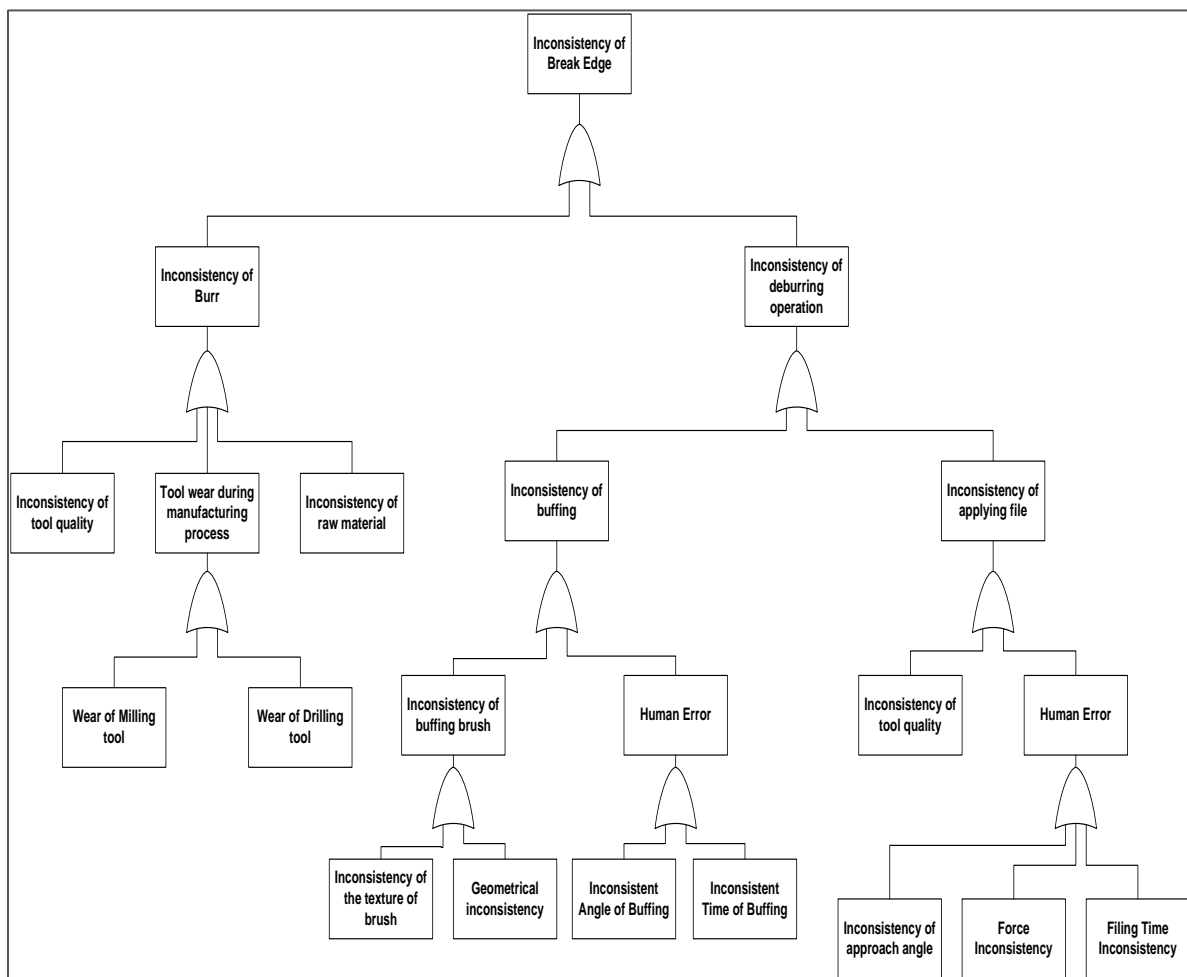

Figure 5-2: Fault tree graphically represents the events, which cause the inconsistency of break edge.

Inconsistency of burr geometry

Inconsistency of burr geometry can be addressed to both burr size and burr shape around the drilled holes. Burr size and burr shape can vary not only around each hole but also from hole to hole. The burr geometry is considered as an input for deburring process. Thus geometry variation of the burr leads to inconsistency of the deburring results, even using a consistent deburring process. The geometrical variation of the burr can be addressed to three different origins:

- **Inconsistency of raw material**

The quality of the bar stock delivered at shop floor is already approved when it was delivered at company store and its physical and mechanical properties are in a standard range. Within the acceptable range, some parameters such as hardness, which have significant effect on manufacturing and machining results, varies per bar stock. It has been observed that some bar stocks has variable radial hardness repartition. Accordingly the hardness changes along the radius of the bar stock. However, currently, all bar stocks delivered at shop floor are heat-treated before being manufactured, they still have small differences, which can cause geometrical inconsistency of the burr.

- **Inconsistency of tool quality**

Delivered tools at shop floor, as well as the raw materials, are approved to meet the quality requirements. The tool material and geometry is in a standard range. Although in previous investigations, it has been observed that tools from the same delivered batch create different burrs. This can be attributed to small differences in two parameters that have a limited tolerance in standard range: geometry of the tool, and the coating property.

- **Tool wear during manufacturing process**

Tool wear, which occurs during manufacturing process has a significant role in projecting unwanted material at workpiece edges. Burr size increases with tool wear. In this study two operations, which produce the target holes, are drilling and end milling. Wear phenomenon in both of drill and end mill tool increase the burr size and consequently cause inconsistency of burr geometry during manufacturing.

Inconsistency of Deburring Operation

Inconsistency of manual deburring is another possible reason of variation of break edge. In this stage a survey was conducted on the current deburring operation at shop floor. Figure 5-3 represents the manual deburring steps, which are currently applied to air-swirlers. In order to find the sub-processes, which produce the break edge, data was gathered via examination and measurements in addition to pictures. Four random sample parts were given to different operators to be deburred. The samples were collected in each deburring step and after investigation returned to the same operator for next step. The collected samples were investigated under microscope in order to assess the state of workpiece edges.

The investigation showed that the grinding wheel does not create any break edge. It only removes large burrs and slightly bends the smaller burrs into the hole. Figure 5-4 shows the workpiece holes after applying grinding wheel. No large burr is observed in the picture and the light burrs are bended into the hole so they can be easily removed with the file.

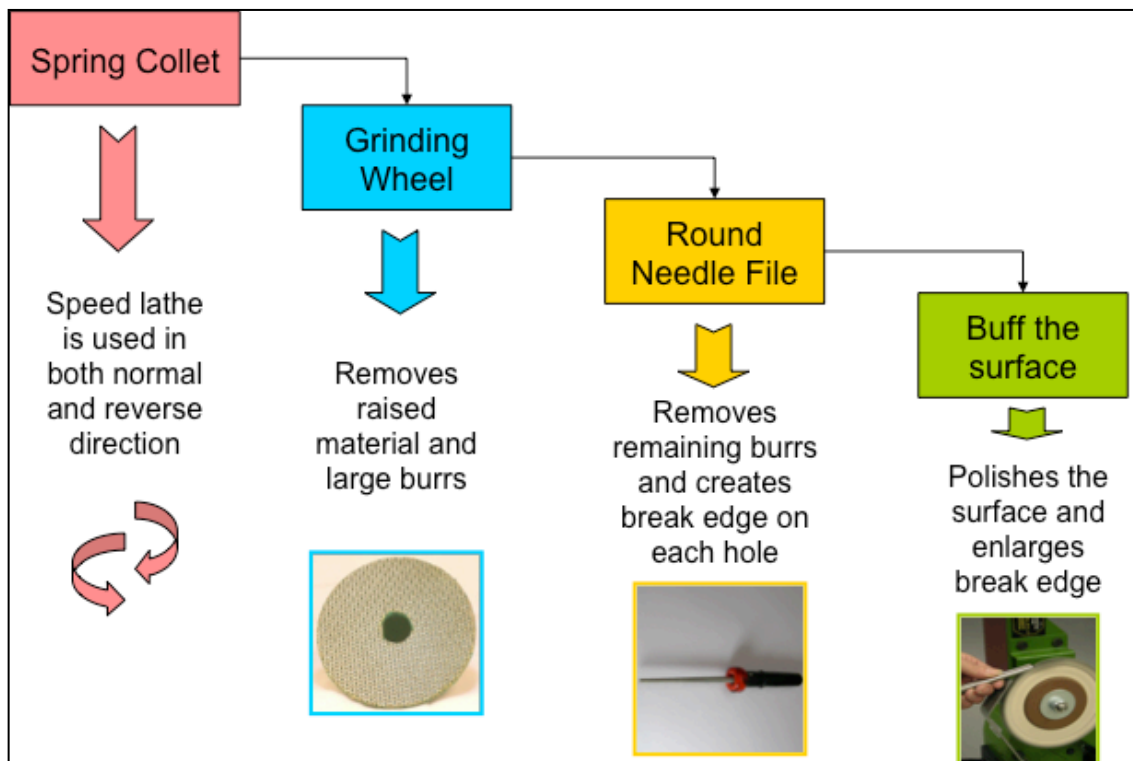

Figure 5-3: Air-swirler manual deburring steps

The bended burrs are removed completely when the round needle file is applied to the hole. The operator removes the burr with manual reciprocation of file. The applied force and reciprocation time depends on severity of the burr and also operator's decision. The operator continues deburring action until he ensures that no burr is left on the edge and sufficient break edge is created.

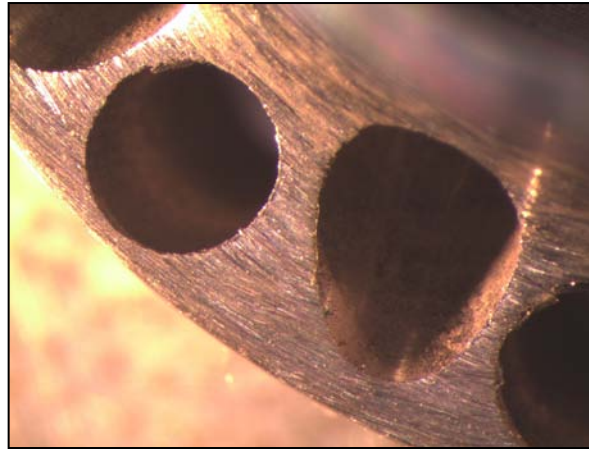

Figure 5-4: Air-swirler holes after applying grinding wheel

Figure 5-5 shows the edge of the hole after applying file. It can be observed that the break edge is extremely small and the break edge profile is wavy, rough and variable around the hole. In this stage the break edge was measured and the measured holes were marked to be tracked at next step.

The buffing operation polishes the surface. At the same time it enlarges the break edge. The wavy and rough profile of the small break edge is smoothed and developed by the rotary abrasive brush. Buffing operation is performed by the operator and buffing time and angle highly depends on operator. Investigations revealed that the average break edge created by file approximately doubles after buffing operation. The measurements were conducted on all test samples and 5 random holes were tracked during the investigation. Figure 5-6 represents the break edge before and after buffing operation. One can observe that the wavy and inconsistent profile became smoother, larger and more consistent around the hole.

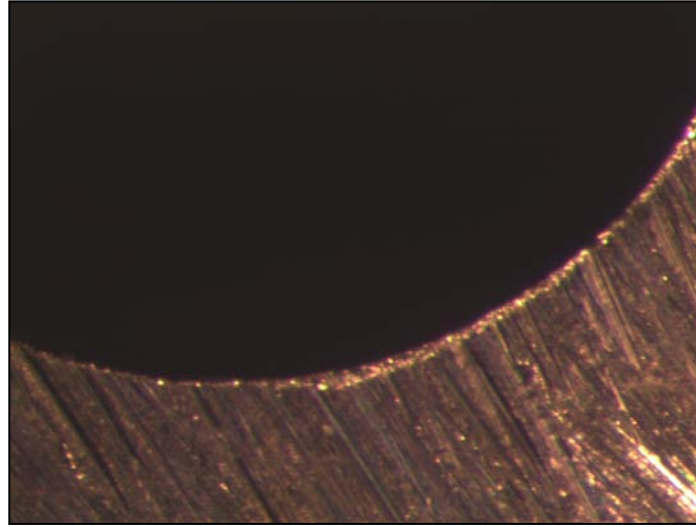

Figure 5-5: Hole edge after applying round file

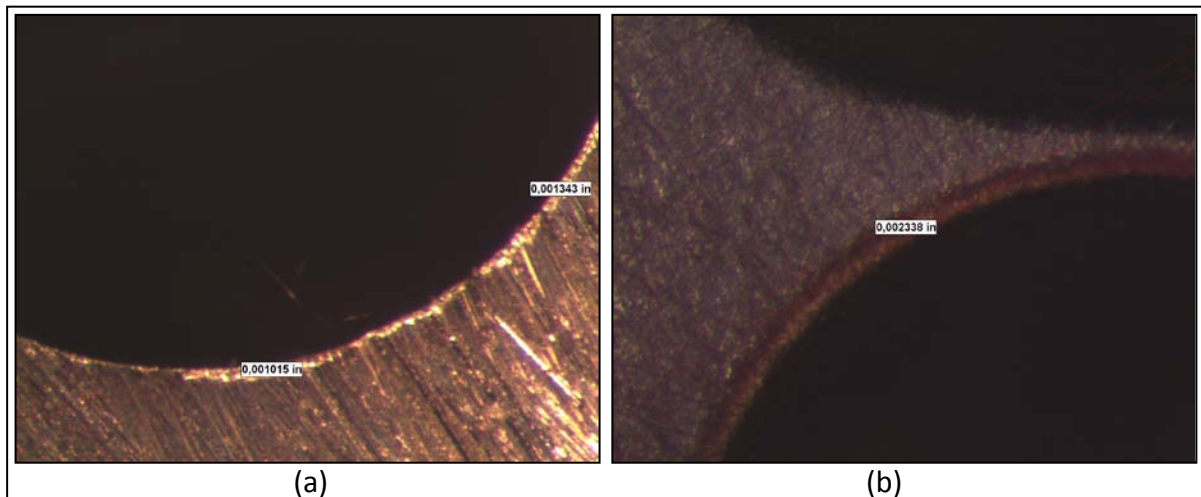

Figure 5-6: The wavy break edge created by the file (a) becomes smoother and larger after buffing operation (b)

From the survey above, it can be concluded that filing and buffing are two operations, which are involved with creation of break edge. Since the average measured break edge after buffing is approximately twice as wide as the measured break edge after filing, the percentage of participation in break edge production of two processes can be assumed equal. Thus both of them are assumed to have the same ability to taint the deburring result. One can find the detailed observations and measurements in the next chapter.

Human error is another important reason of irregular break edge during filing operation. Each operator applies the file on his own specific approach. This approach includes the angle of

operator's hand, the applied force and the operation time or the number of reciprocations. All three mentioned factors can vary not only per operator but also per hole because; the operator may change the angle of his hand, the force and, the number of reciprocations because of tiredness, variable size of the burrs or, many other different reasons. Any of these three or any combinations of them can produce an inconsistent break edge.

The buffing process has the same importance as filing. The inconsistency of the buffing process can be a result of brush inconsistency. A batch of buffing brush can have inconsistency in brush texture. For example two brushes from the same batch can have different grades of aggressiveness, even if they have same specification and same abrasive properties. Moreover the brush loses texture during the operation. This loss of texture is not uniform. Thus it produces geometrical un-uniformity of the brush. The geometrical inconsistency of the brush affects the deburring results.

Since the process is manually performed, the human error is another important possible reason for inconsistency issue. The angle, which, the operator holds the part against the buffing brush and, the buffing time are two operator dependent parameters. Thus the results can be affected due to variation of these two parameters that source from human error.

5.1.1.3 Experiment objectives and quality characteristics

The project objective is to improve consistency of deburring result. But the important challenges are how to measure consistency and how to evaluate the improvement.

To aim this goal, meaningful quality characteristics should be measured. The quality characteristic should be able to represent the consistency in meaningful manner. The characteristic also should reflect the effect of important parameters. In other words, it should vary with change of affecting parameters such as applied force during filing, filing and buffing time, etc.

Measurable characteristics are those, which have a numerical value such as width, height, and thickness. In this study the width of break edge is the most important measurable characteristic. The break edge variation can be used to represents the level of consistency of current deburring process. Furthermore variation of each important factor affects the break edge. Break edge was selected as dependant variable of the experiments.

Another measurable characteristic is burr size. Burr size was considered dependent variable of preliminary tests. The initial tests were conducted to categorize the independent variables. Since the burr size can be considered as the input of deburring process it is considered as independent variable in main experiments.

5.1.1.4 Measurement system selection and constrains

To measure the air-swirler features such as burr size and break edge various options are available outside and inside Pratt and Whitney Canada. Parts can be inspected outside P&WC if NDA (None Disclosure Agreement) is signed with concerned company. Since the test samples are actual production parts and limited time is available for conducting the tests it is easier and quicker to measure the parts inside P&WC. Hence selecting the measuring device is limited to the available equipment within the company.

Available measurement devices:

Coordinate Measuring Machine (CMM)

The available CMMs within P&WC use mechanical probe to measure geometry of the parts. Since the parts are very small and the minimum required gage resolution should be 10% of the total tolerance, the device is not appropriate for this study.

3-D Laser Scanner

The 3-D laser-scanning device can be employed for scanning the geometry. The laser scanners send light photons to the objected surface and build the surface geometry based on reflection of the light. These devices are applicable for shiny materials but the result is really poor. To avoid the noise created due to shininess of the material, developer can be used. The developer provides a tiny layer of powder on the surface, which reduces the brightness of the surface. Since the thickness of the powder layer is more than edge tolerance, applying the powder changes the geometry of the edge. Consequently part tolerance becomes an issue when developer is implemented. Thus despite the precision of the device, it cannot be applied in this study.

Tomography Device

This device builds 3-D images through applying x-ray to create 2-D sectional images of a part and then provides complete geometry. The resolution of the device is of concern while measuring. The available machine in P&WC does not provide enough resolution to measure small features in scale of 0.01 inch. Thus it cannot be employed for feature measurement.

Cyber Scanner

Cyber scanner is a small laser scanner device that creates 2-D profile on an oscillogram. The laser ray passes through the surface following a straight line along the axis, which has been set up. The output is a sketched graph, which demonstrates feature height variation and length. The device is not applicable for round feature because of the straight passing line of the laser. Since the features on air-swirlers are drilled holes, the device is not appropriate for investigating the geometry.

Optical Microscope

Various optical microscopes are available within the company. The optical microscope is not the most precise measuring device but it is the only one that is applicable for this study due to its capability of capturing complex geometries and curved profiles. The maximum available magnification of the microscope, which is selected for this investigation, is 50X. The device set up is manual but various part holders and available precise fixing equipment can reduce the inconsistency of measurement and compensate the human error. Since the part fixing is identical, the measurement remains consistent.

5.1.1.5 Measurement Process Certification

The measurement process should be certified for each individual part number. Thus it was qualified in accordance with P&WC standard Gage R&R process. Measurement System Analysis (MSA) was based on quantitative data, which estimated total measurement system variation. The MSA evaluates 3 main characteristics of the process: Capability, Repeatability, and Reproducibility.

The process capability considers measurement variations, whereas the repeatability shows the gage variations and the reproducibility demonstrates the variations between the operators.

The data was gathered from at least 3 appraisers, 3 parts, and 5 replicates for each feature. The measurement was random so the operator was not informed which part he was measuring. This distribution approach selected to prevent operator bias. Then a statistical analysis was performed to verify the measurement variation.

5.1.1.6 Selecting process factors

Selecting the process parameters is the backbone of experiment design. Based on the root cause analysis the variation of the deburred edge can be addressed to the operators and variable burr size.

Based on the literature, the size and the profile irregularity of the burr increases with the tool wear. Thus the tool wear can be considered as a parameter, which represents both burr size and shape. In other words, tool life can be selected as the process parameter as it can reflect two different characteristics of the burr. To assess the hypothesis, preliminary experiments were conducted. The experiments aimed to investigate the effect of tool wear on burr characteristics as well as assigning appropriate factor level to it. The part A was selected for primary tests due to the severity of its burr issue. The size and the shape of the burr were monitored during two manufacturing cycles. During each manufacturing cycle, four samples were collected and measured in various stages of the tool life. Burr size is measured on six holes of each part and each measurement repeated three times.

There are two different tools, which go through the holes: the drill and the end mill. In this study, the total number of the parts that each tool manufactures before being replaced is called the maximum tool life duration, which is different for the end mill and the drill. The Total Tool Life Percentage (TTL) is indicated as a parameter in which the tool life of the both tools is considered. Formula (5-1) demonstrates the calculation of this parameter

There are two different tools, which go through the holes: the drill and the end mill. In this study, the total number of the parts that each tool manufactures before being replaced is called the maximum tool life duration, which is different for the end mill and the drill. The Total Tool Life Percentage (TTL) is indicated as a parameter in which the tool life of the both tools is considered. The TTL explain the percentage of usage of the tool. Formula demonstrates the calculation of this parameter

$$\text{Total tool life percentage} = \left[\left(\frac{L_D}{L_{Max D}} + \frac{L_E}{L_{Max E}} \right) / 2 \right] * 100 \quad (5-1)$$

Where,

L_D = Number of the parts that the drill manufactured

$L_{Max D}$ = Maximum tool life duration of the drill

L_E = Number of the parts that the end mill manufactured

$L_{Max E}$ = Maximum tool life duration of the end mill

The samples were collected when the total tool life percentage was 10, 40, 70, and 94.

Based on the observations and measurements, it was concluded that the tool life significantly affects the burr characteristics. Moreover three different stages were identified for the tool life:

- **New tool (TTL < 25%)**, which creates slight burrs without drill cap
- **Mid-life tool (25% < TTL < 75%)**, which creates medium size burr with attached drill cap on some of the holes.
- **Dull tool (TTL > 75%)**, which creates large crown burr or transient burr with semi-developed drill cap.

Thus the tool wear was selected as one process factor and three levels were assigned to it as discussed. One can find the detailed results and related graphs and tables in next chapter.

Since the current deburring process is manual, the human error has a significant impact on the inconsistency of the results. As mentioned before the filing and buffing operation equally participate in break edge production. Thus both of them were assumed to have the same influence on the variation of the deburring results. Consequently the human error was assumed to be the same for both processes.

The operator was selected as another independent variable of the process. Four levels were assigned to the factor that represents the number of bench operators, which performed the deburring operation in each manufacturing cycle. This number may vary depending on high or

low production volume of each cycle. Four is optimum number of levels for this factor because it is high enough to indicate the variation of the results adequately, and low enough to avoid investing excessive time and money.

The hardness of the raw material, the quality and the geometry of the tools in machine center and in deburring booth can also be listed as process factors. Nevertheless including them in experiment process induces severe complications.

Large volume of the tools is utilized during each manufacturing cycle. Categorization of the tools based on their geometrical profile requires specific experiments which are costly and time consuming. Moreover measuring and testing detailed geometrical profile of the tools before manufacturing creates a bottleneck in production line. As another issue, it is almost impossible to track them one by one through the manufacturing cycle.

The harness of bar stock is tested on the bar's surface before manufacturing. It is impossible to measure the hardness of different sections of the bar stock without cutting it. Thus inconsistency of longitudinal hardness repartition cannot be tested before manufacturing.

5.1.1.7 Orthogonal array and experimental runs

To examine the effect of each parameter experimental runs are organized using Taguchi orthogonal arrays. The array was selected based on number of parameters and number of levels. Since maximum number of levels is 4, the $L_{16}(4^5)$ array was selected primarily. Then it was adjusted with respect to specific condition of this study.

The array $L_{16}(4^5)$ can assess five parameters, each at four levels. In this study 2 parameters are assessed. Thus the last 3 columns, which represent the additional parameters, are eliminated. Since one of the process parameters have 3 levels, the last 4 raw that represents the fourth level of parameter 1, are eliminated. Finally 12 experimental runs are left. It can be seen that, number of Taguchi-based experimental runs is equal to the full factorial experiments in specific case of this study. One can find the modified array in Table 5-1 represents the array L_{16} specifically modified for this study.

During the experimental runs for every part number, each operator deburred 3 samples: a part with small burr, a part with medium size burr, and a part with large burr. One can observe the experimental runs in Table 5-2.

Table 5-1: Modified array $L_{16}[4^5]$ [67]

Experiment	Parameter 1	Parameter 2	Parameter 3	Parameter 4	Parameter 5
1	1	1	1	1	1
2	1	2	2	2	2
3	1	3	3	3	3
4	1	4	4	4	4
5	2	1	2	3	4
6	2	2	1	4	3
7	2	3	4	1	2
8	2	4	3	2	1
9	3	1	3	4	2
10	3	2	4	3	1
11	3	3	1	2	4
12	3	4	2	1	3
13	4	1	4	2	3
14	4	2	3	1	4
15	4	3	2	4	1
16	4	4	1	3	2

Table 5-2: Experimental runs

Experiment run	Operator number	Tool condition
1	1	New
2	1	Mid-life
3	1	Dull
4	2	New
5	2	Mid-life
6	2	Dull
7	3	New
8	3	Mid-life
9	3	Dull
10	4	New
11	4	Mid-life
12	4	Dull

5.1.2 Implementation

To obtain a reliable result, it is essential to have a robust sampling strategy. It is also important to avoid systematic bias during measurements. In this section one can find the experiment strategy as well as the randomization method.

5.1.2.1 Sampling strategy and randomization

The twelve samples are gathered during manufacturing runs of part numbers A to D. In each level of tool life, four samples were collected and measured. Then the samples randomly distributed among the operators. The operators were asked to deburr the parts during their working shift but no specific time restrictions were applied. In the other words, the samples had the chance to be deburred at anytime of the day. Furthermore they were asked to pick the samples randomly. Thus the samples are not deburred based on the sequence of burr size level.

The samples were collected in one manufacturing period so the machine set up was identical for all samples. Each part has several holes, so the repetition of each experimental run can be accomplished by measuring the break edge on different holes of the part. Accordingly five holes around each part were randomly selected for measurement.

5.1.2.2 Measurement strategy and randomization

To avoid systematic bias during measurements, replication was selected as the randomization method. All parts were mixed and every sample had equal chance of being selected for measurement.

Each feature measured through three observations around the hole periphery. First, five holes were selected randomly. Then the break edge was measured on each hole. Then the measurement repeated two times with a random sequence. Finally the average of the measured values of each hole is established as the size of break edge.

5.1.3 Analysis

Multifactor Analysis of Variances (ANOVA) method was the basis of the analysis. Statistica software was employed for analysis of the results.

5.2 Complementary experiments

The analysis of experimental data, which was gathered during pervious stage, stated a significant influence of both parameters in deburring results. Hence, feasible solutions should be assessed considering both parameters. Complementary experiments were conducted for two main purposes:

- Acquiring further information where more detailed and precise investigations were needed.
- Validating the feasible solutions.

To tackle the burr size variation, the parts were monitored during manufacturing cycle. Then, based on the observations, second series of tests were conducted to validate the assumptions and obtained results.

To replace the manual process with an automated one, several alternatives could be selected, which one of them was experimented with respect to project budget and equipment availability. One can find the detailed results and discussion in next chapter.

5.2.1 Investigation of burr formation during manufacturing

The burr volume increases with the tool wear. Furthermore, as the tool wear expands, the burr profile tends to transiency and irregularity. To obtain a consistent burr profile with the minimum possible burr volume, a robust strategy is required. The burr minimization strategy can be established based on an inclusive experimental data gathered during manufacturing. The part number A is monitored during the manufacturing cycle. The experiments aimed to find the critical tool life in which the uniform burr starts to transform to crown and transient burrs. During a period of tool life the manufactured parts were investigated. The burr was measured and the burr shape was assessed on the every hole around each part. Then, the average of the measured burrs around the parts was established as Average Burr Size of the Part.

The investigation conducted on two manufacturing runs. Twelve samples were collected in each run. The first sample was taken when the drill and the end mill are both new. Sample twelve was the last sample that the drill manufactured. Burr formation and burr development was studied for samples.

During the burr formation experiments, certain evidences of temperature elevation were observed. The burr formation pattern illustrated that certain areas appear to be affected by high temperature. Therefore other series of tests were designed and conducted to study the effect of temperature.

The tests were conducted in the machining lab of Ecole Polytechnique de Montreal. The test material was provided by Pratt & Whitney Canada. The cutting conditions of the manufacturing line were used for the tests. There are two types of holes on the real parts, which can be observed in Figure 5-7. The larger holes which are shorter and the smaller holes which are longer. The holes of the real parts are inclined so the length of the hole is longer than the thickness of the part. The thickness of the test samples was set equal to the length of longer holes. The tool usage was established based on number of the holes it produced. Thirty holes were produced on each sample part. In order to reduce the temperature, the parts were mounted on a vertical lath so the coolant can easily flow inside the hole through the manufacturing process. The temperature of the drill tip was recorded via infrared camera after producing every six holes.

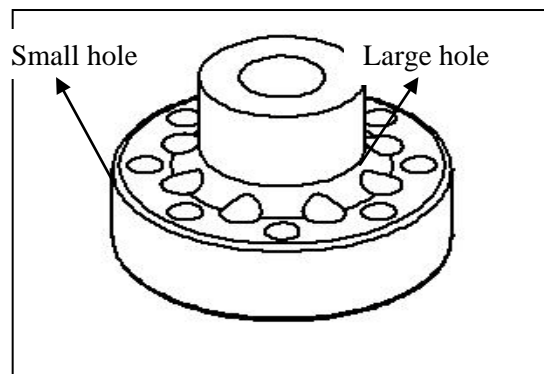

Figure 5-7: Schematic of the holes on the samples

5.2.2 Evaluation of alternative deburring processes

Producing uniform burr in addition to using an alternative deburring process can tackle both root causes of the inconsistency. Among the applicable deburring processes, Magnetic Abrasive was selected for feasibility test with respect to available equipment and project budget.

5.2.2.1 Magnetic Abrasive Deburring Test

The magnetic abrasive process was employed to deburr the parts. The samples were sent to Earth Chain Company for experimental runs. Part numbers A, B and D were selected for the tests. Due to the geometrical similarity of part numbers B and C, one of them was selected as the representative of both. Part number B was chosen since it has more complex features and larger burr size. The dimension of the parts was measured before sending them for the tests.

Table 5-3: Magnetic abrasive deburring experimental runs

Media Size	0.5*3mm		0.7*3mm		1*3mm
Part A	N/A		10 min	20 min	20min
Part B	10 min	20 min	N/A		N/A
Part D	20min	N/A	10 min	20 min	N/A

Through two cycle times, the samples were deburred using three different media sizes based on their dimensions. One can find the experimental runs in Table 5-3.

After investigating the ability of magnetic abrasive deburring the process was experimented one more time. In second run the edge of the holes were prepared somehow they were burr free and without break edge. The operators were asked to remove large burrs without creating break edge on the holes. Then the break edges were created via the magnetic abrasive device.

5.3 Inconsistency criteria

The objective of current study is to improve the state of consistency. To evaluate the improvement strategies a comprehensive comparison based on a reliable criterion is required. Since the inconsistency is a qualitative characteristics of the process. To express the inconsistency in a quantitative manner 3 criteria are introduced and assign value. Parameter μ is used as the basic concept and it developed to 3 criteria. The parameter is defined based on statistics of gathered data. The distribution is normal and mean of the data, which is showed by M , is used as the center of data set.

$$\eta_a = \frac{n_a}{N} \quad (5-2)$$

Where:

η_a = inconsistency of deburring results

a = interval value which can be selected from 0 to 1

$n_{a/2}$ = number of observations that do not include in interval $[M-a/2*M, M+a/2*M]$

N = total number of observations

For example for $a=0.1$:

$$\eta_{10\%} = \frac{n_{0.05}/2}{N} \quad (5-3)$$

$n_{0.05}$ = number of observations fall outside of the interval $[0.95M, 1.05M]$

Three main criteria that are used in study are $\eta_{10\%}$, $\eta_{20\%}$, and $\eta_{30\%}$.

CHAPTER 6 ANALYSIS, RESULTS, AND DISCUSSION

6.1 Preliminary tests

Design Of Experiments (DOE) aims to comprehensive study of current state of the products and their manufacturing process. An essential step toward the Design Of Experiments is to form a basic idea of the process, determining process factors and assigning adequate levels to them. Through the root cause analysis, both the machining and the deburring process are investigated.

Preliminary tests were designed to establish a reliable structure for main experiments. As mentioned before, four different part numbers are involved in current study. A consistent experiment strategy should consider process parameters with proper levels. The number of levels should be enough to show the variations but, not excessive to expand the experimental runs and impose extra experiment cost. Conducting the tests on manufacturing line is a time consuming process since the experiments should be scheduled based on the manufacturing timetable. Hence, performing the primary tests for the four targets could delay the main experiments for months. On the other hand implementing four different experimental plans in shop floor can induce complications and increase the sampling errors, since the experiments involve manpower. Thus, one part number should be selected as the representative of the four. The part number should address the effect of all possible levels of process factors.

Part number A was selected as the representative of other parts because of its geometrical complexity and the limited manufacturing options to reduce the burr size on machine center. Furthermore, the size of the holes on these parts causes more severe burrs around the edge. The structure of main experiment was designed based on the primary tests of part A. Then, it was applied to the three other parts. If the experimental structure includes redundant levels for a specific part, non-significancy of the levels can be determined through the statistical analysis.

6.1.1 Preliminary investigation of machining process

The results of the machining process can be considered as the input for deburring process. Hence, the burr produced during the machining process should be studied. The burr formation on the parts is dependent on the tool path planning, the cutting conditions, and the tool wear [11].

Through the study of the current state of the parts, tool path planning and the cutting conditions remain constant, so they cannot be considered as process parameters. The tool wear is the only parameter, which changes during machining process and induce the burr variation. There are different tools, which are applied to these parts, although only some of them involve in the burr formation process.

The holes are produced through the parts using four operations: spot drilling, center drilling, drilling, and end milling. From these four, only the last two operations participate in burr formation. There are two different holes manufactured in these parts: large holes with short length, and small holes, which are relatively longer. Same drill size is used for creating both kinds of the holes. The diametrical difference is generated via applying the end mills.

Since the tool life of the drill is different from the tool life of the end mills, Total Tool Life (TTL) is used to indicate the state of tool life as discussed in methodology chapter. It should be mentioned that the tool life of the two end mills are different. On the other hand, the tool lives of the large end mill and the drill are equal. Thus, the tool life of the large end mill is not used in calculation of TTL.

Test samples were collected in different TTLs during two manufacturing runs. From each manufacturing run, four samples are collected in different stages of tool wear. The burr height was measured on the edge of six random holes and the average of measured values was used as the burr size of each part.

Figure 6-1 shows the observed burr size for six holes around each sample. The average of observed values is used in Figure 6-2 to represent the relationship between the burr height and TTL.

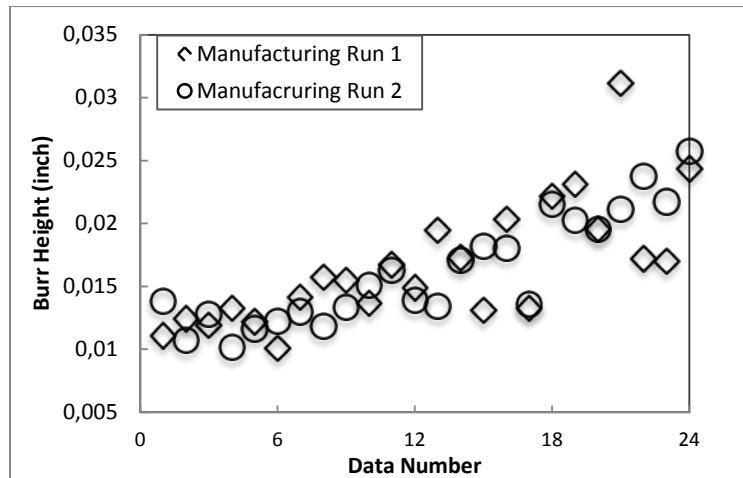

Figure 6-1: Observed burr height valued for the samples gathered from two manufacturing runs

In Figure 6-1, it can be seen that, for smaller burrs observed values are closer to each other. As the size of the burr increase, the observed values are spread in wider area. Based on plotted data in Figure 6-2, the larger the TTL is, the larger burrs are observed. It can be concluded that the irregularity of the burr around the part increase with the TTL. With increase of tool wear, more inconsistent burr sizes are observed around the parts. In the other words, the increase of tool wear, decrease the consistency of the edge projections of different holes around the workpiece and consequently reduce the consistency of the deburring process input.

In Figure 6-2 one can see the size of the burr rise with the increase of TTL. The graph is divided in 3 main regions with two vertical lines which represent the TTL=25% and TTL=75%.

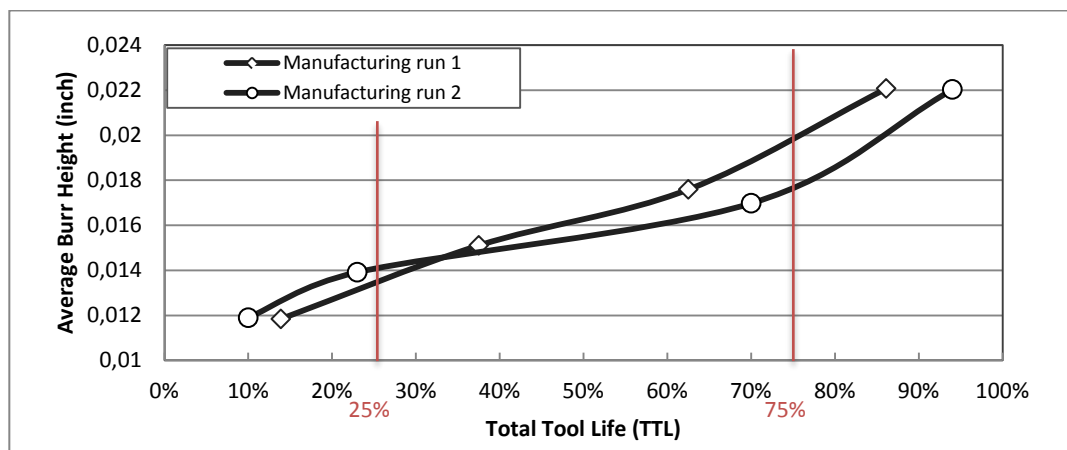

Figure 6-2: Average Burr Height VS Total Tool Life

In the premier region where $TTL < 25\%$, the size of the burr is relatively small. In this region the tool is still sharp and creates small edge projections. That means, if in overall, the tools together are used less than 25% they are assumed to be sharp. Thus the region is called New Tool.

In the second region ($25\% < TTL < 75\%$) the size of the burr slightly increase but it is not extremely large and irregular. This region is called Mid-life Tool.

The third region in which $TTL > 75\%$ burr size increase rapidly. The tool is dull and it creates large and irregular burr around the holes. This area is called Dull Tool.

It can be observed that burr size versus tool life follows the same pattern in both manufacturing runs. Hence, three levels were assigned to the tool wear factor. These three levels represent the state of the tool as well as size, irregularity and severity of the burrs.

6.1.2 Preliminary investigation of deburring process

In order to assess the deburring operation, the bench operators were asked to deburr sample parts. The samples were collected and investigated in each deburring step. The investigation illustrated the state of the holes after each deburring stage. Furthermore, the role and the influence of each step on the shape and the size of the break edge were clarified.

As discussed in methodology, the break edge on the parts is created via three main deburring actions which all are manual. First the part is mounted to a spring collet and it is rotated in two directions: clockwise and counterclockwise. A grinding wheel is applied to the part while it is turning. This action trims large burrs and removes drill caps. Moreover, it bends the remaining burrs into the holes. No break edge is observed around the holes after applying grinding wheel.

Figure 6-3 shows the condition of edges after applying grinding wheel. The remained burr around the hole periphery is not uniform. Some areas still have burrs, although the raised material is removed on other sections. This phenomenon can be considered as one on the sources of inconsistency, which is originated from the geometrical irregularity of the burr that is produced on the machine center.

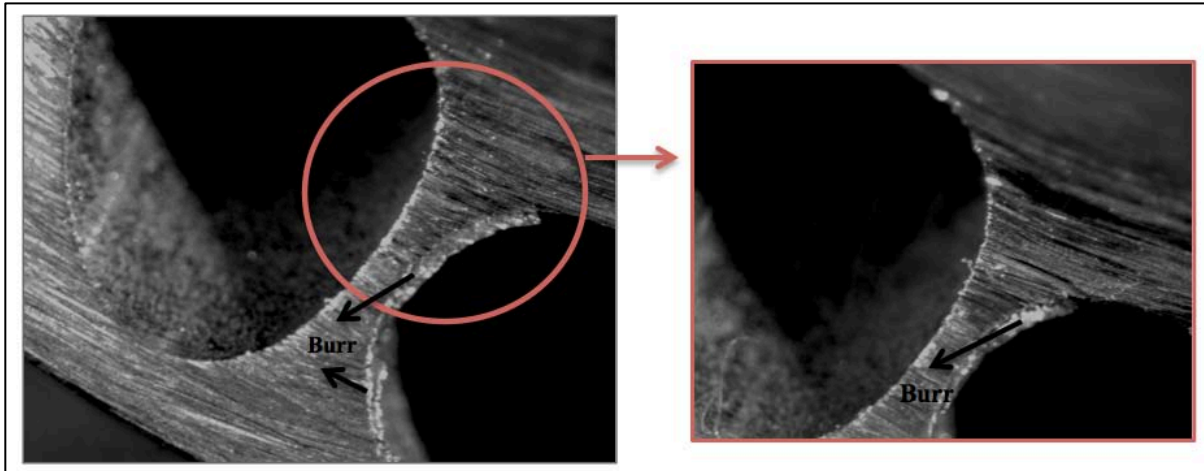

Figure 6-3: Remained burr on the edge after applying grinding wheel

In the next step of deburring, a round file is applied to the holes, which creates a small wavy break edge around the hole. This break edge is smoothed and enlarged during buffing. The buffing action also polishes the surface and ameliorates the surface roughness. One can see the state of the edge after the filing and the buffing in Figure 6-4.

In order to investigate the effect of each step, the break edge was measured on five holes around each sample. Then the holes were marked and the parts were returned to operators for the buffing. The break edge was measured on the same holes after the buffing operation.

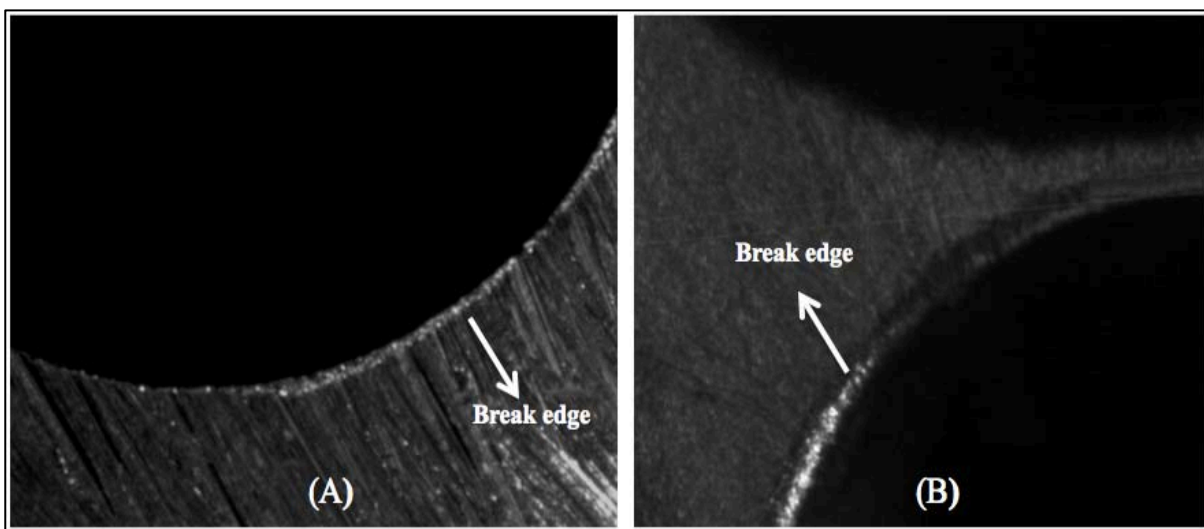

Figure 6-4: Wavy break edge created after filing (A), Enlarged and smooth break edge after buffing (B)

One can find the observed break edge values for the filing and the buffing operations in Figure 6-5. The graph shows 20 observations for each process, which are taken from four samples. After each process, five observations were recorded for each sample. It should be mentioned that each sample is deburred by different operators. Thus, each group of five data numbers belongs to one operator. For example, measured values for data number 1 to 5 is taken from the sample which is deburred by operator 1, and so on. Furthermore it can be observed that both processes follow the same pattern. It can be concluded that the result of buffing process is highly dependent on the primary break edge created through the filing.

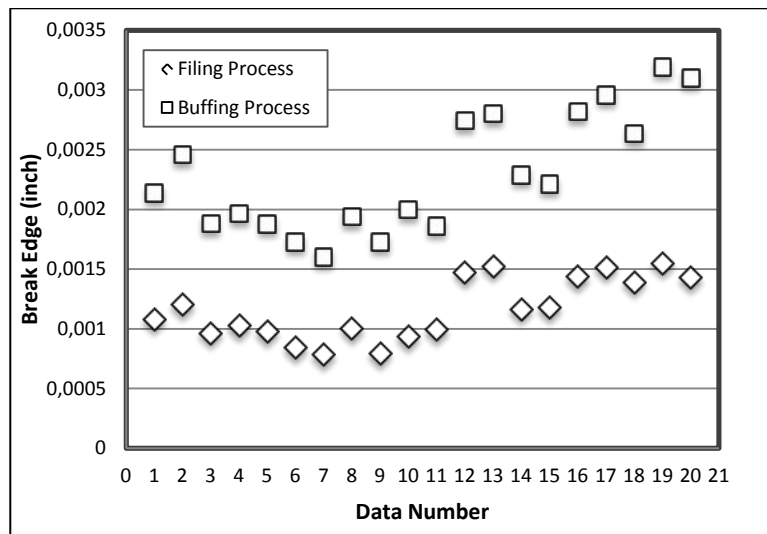

Figure 6-5: Observed break edge values for the filing and the buffing

One can see the bar graph of observed break edge values in Figure 6-6. The numbers on the top of the bars is the break edge after buffing divided by the break edge after filing.

It can be observed that the buffing to filing ratio varies between 1.8368 and 2.1738. The range is very short and it can be concluded that the buffing operation approximately doubles the break edge created during filing operation. On the other words, the break edge after the filing and the buffing can be assumed proportional with the constant ratio of 2. It means the influence of the two processes can be assumed equal in final break edge value. Based on this assumption, it is not necessary to consider result of each process as an individual dependent variable. Both of the processes can be considered as one single operation. Thus the break edge after buffing is considered as the only dependent variable in this study.

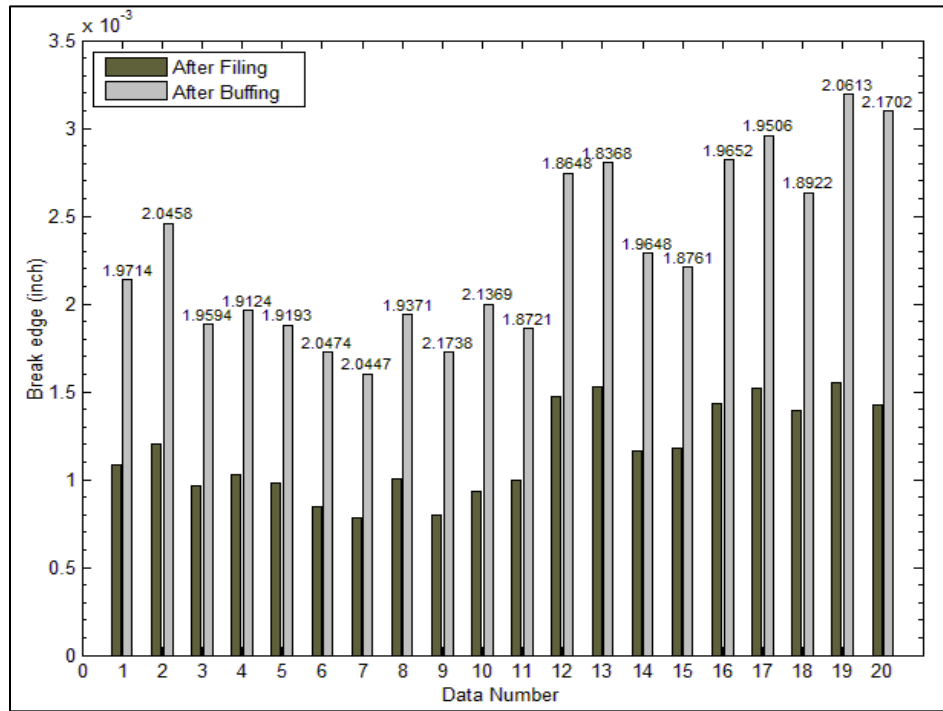

Figure 6-6: Bar graph of observed break edges after the filing and the buffing operations

6.2 Statistical analysis of experimental data

After conducting the designed experiments, the data was analyzed via statistical technique, which can represent the significance of the factors and the interactions. Analysis of variances (ANOVA) was performed for determining the significance of parameters and percent contribution as well as verifying the homogenous levels. Null hypothesis of F-test is used to evaluate if the factor is statistically significant. The hypothesis says that the means of different levels of each factor are equal. In this section one can find the descriptive ANOVA results for each part number.

6.2.1 Part A

The burr distribution for part A was reviewed in previous sections. In this section the statistical results are discussed.

Table 6-1 shows the summary result of ANOVA for break edge. It can be observed that P-value for both of process parameters and their interaction is smaller than 0.05. The null hypothesis for F-test is rejected. Thus, at least two levels of each particular factor do not have equal means. The factors for which the $P < 0.05$ is statistically significant. It can be concluded that size of the burr,

the operator and the interaction between them significantly affect the size of the break edge. The percent contribution can be observed in the table. Operator has major influence on the variation of break edge. Burr size as another important parameter significantly affects the break edge. The interaction of break edge and operator has relatively small effect the break edge. The term error describes the effect of other parameters, which are not investigated in this study. In the industrial cases, when the experiments are conducted on a real manufacturing line instead of an ideal environment or a lab, many hidden variables can affect the experiments. These variables are real factors which neither can be identified and nor can be eliminated as noise. Instead, their contribution can be observed in statistical investigation as the term error. It can be observed that the contribution of hidden variables is smaller than the two main variables of this study. Thus it can be concluded that the selected variables are the most influential parameters in the consistency of the break edge.

Table 6-1: Summary of ANOVA for break edge (Part A)

Factor	Degr. Of Freedom	Break edge (inch) SS	Break edge (inch) MS	Break edge (inch) F	Break edge (inch) P	Percent of Contribution
Burr size level	2	7.095471E-06	3.547736E-06	28.262	0.000000	23.97
Operator	3	1.464716E-05	4.882387E-06	38.895	0.000000	49.48
Burr size level*Operator	6	1.832237E-06	3.053728E-07	2.433	0.039141	6.19
Error	48	6.025350E-06	1.255281E-07			20.36
Total	59	2.960022E-05				100

Main effects are plotted in Figure 6-7 and Figure 6-8. It can be observed that the break edge increases with the tool wear. As discussed before, tool wear increases the size of the burr. For the manual deburring process, the larger the burr, the larger the break edge. To explain this fact, deburring operators were consulted and the process was surveyed more closely. The operators revealed that the larger burrs are harder to remove so they need to apply more force during the filing operation. Furthermore, they repeat the filing action more times when the burr is bigger. This leads to larger break edge for larger burrs. It can also be observed that the break edge slightly increases between the new tool and mid-life tool. Though, the break edge mean for the dull tool is considerably higher than the means of the two other levels.

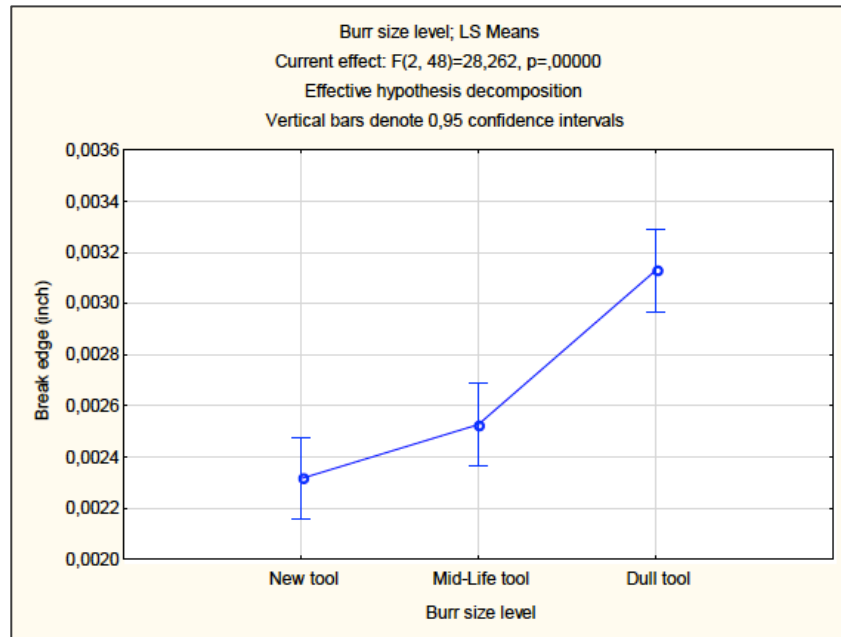

Figure 6-7: Effect of burr size level on break edge (Part A)

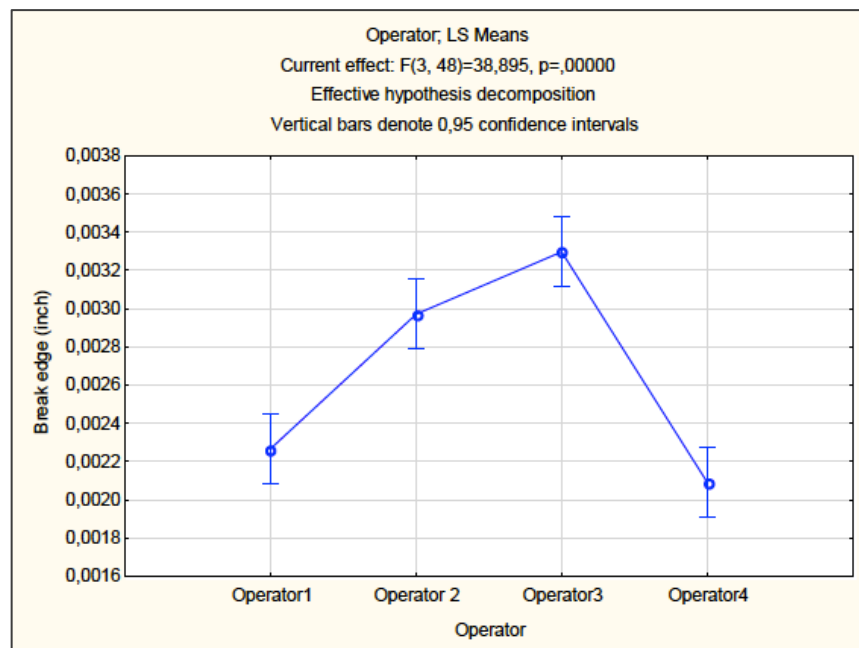

Figure 6-8: Effect of operator on break edge (Part A)

The mean of the break edge created by each operator is shown in Figure 6-8. The mean break edge created by operator 1 and operator 4 are relatively smaller.

One can see the effect of both parameters together in Figure 6-9. It can be observed that except the Operator 1, which created smaller break edge for Mid-life tool, all others created larger break edge with increase of burr size.

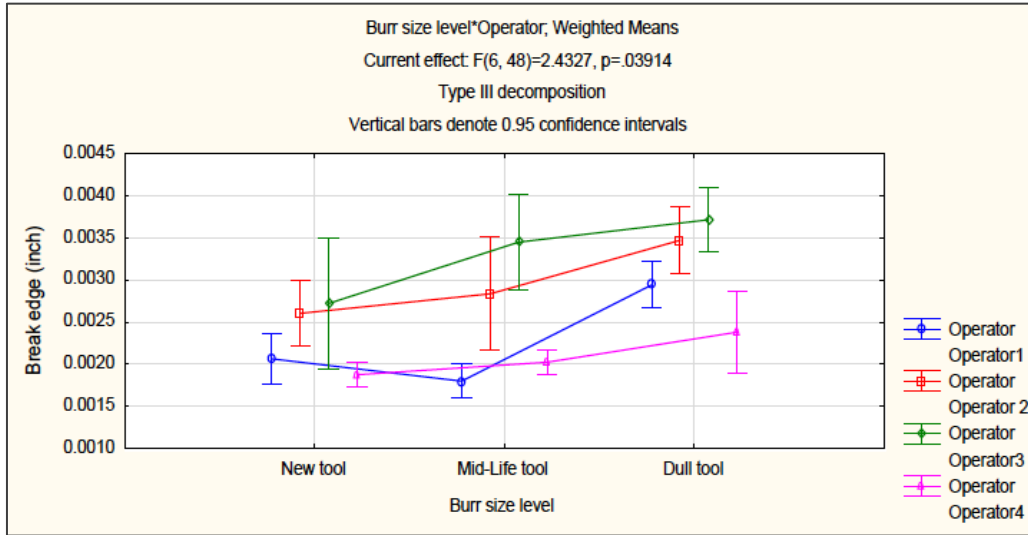

Figure 6-9: Effect of burr size and operator on break edge (Part A)

Post-hoc tests can classify the levels of a variable. Two types of homogenous groups tests (Tukey and Scheffe) were conducted on the data. These test compare the variance for different groups of data and classify the levels, which has homogenous variances. The results in Table 6-2 reveals the different levels of burr size can be classified in two main groups. The first and second levels (New tool and Mid-life tool) are classified in same group using both methods. Dull tool is classified in a separate group since it has significantly higher break edge mean.

Table 6-2: Post-hoc tests for burr size (Part A)

Scheffe test; variable Break edge (inch) Homogenous Groups, alpha = .05000 Error: Between MS = .00000, df = 48.000				Tukey HSD test; variable Break edge (inch) Homogenous Groups, alpha = .05000 Error: Between MS = .00000, df = 48.000					
Cell Number	Burr size level	Break edge (inch)	1	2	Cell Number	Burr size level	Break edge (inch)	1	2
1	New tool	0.002316	****		1	New tool	0.002316	****	
2	Mid-Life tool	0.002527	****		2	Mid-Life tool	0.002527	****	
3	Dull tool	0.003128		****	3	Dull tool	0.003128		****

Examination of residuals is essential for all statistical models, and for especially Design of Experiments (DOE). The distribution of residuals is the touchstone to determine the reasonability

of the assumptions, and independency of observations. The residuals are plotted in Figure 6-10. The plot does not show a specific pattern. Thus it can be concluded that the observations are independent and the assumption of constant variance of residuals is accepted. This validates the model and the discussed results.

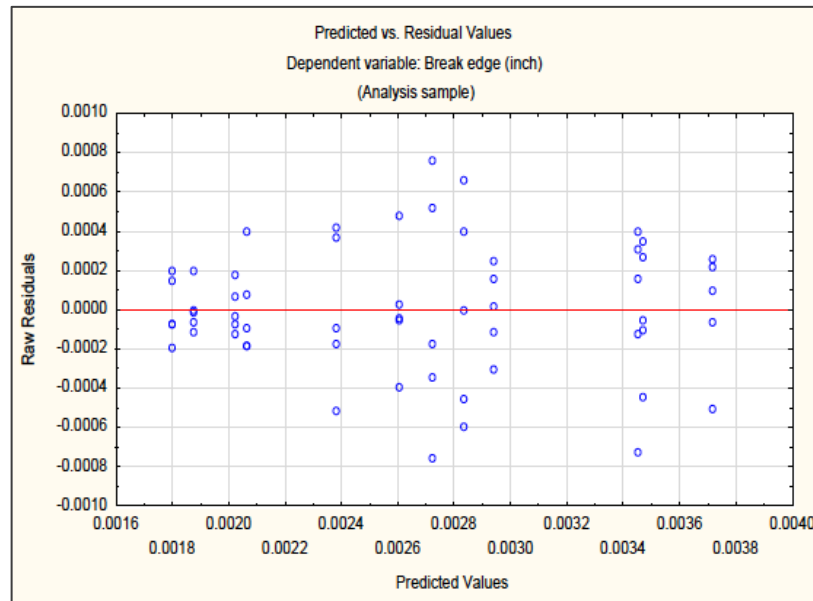

Figure 6-10: Residuals vs. predicted values (Part A)

6.2.2 Part B

In order to better understanding the ANOVA results and performing a good comparison between the parts, the state of manufacturing is investigated as well as the part geometry and burr size. The burr was measured on random holes of the collected samples. Then the samples are given to operators for deburr.

Part B is smaller than the Part A. The size of the holes is approximately 0.7 of the size of the holes on Part A. The inclination of the holes is less than the part A. Furthermore the holes are more accessible because of their distance from the neck of the part. Owing to the geometry of the part free cut operation with 0.0004 inches clearance is employed to remove the large burrs after producing the holes. Using smaller clearance for the operation induced sever tool chipping and chatter. Although the free cut operation trims large burrs, some small and irregular burrs still remain around the hole periphery. The inconsistent profile of the remaining burr can be observed in Figure 6-11. The left burr after free cut is relatively small but it still follows the increasing-

with-tool-usage pattern as part A. The burr was measured on twelve samples. Four parts from each tool life stage were collected. The burr was measured on five random holes of each part. It was observed that with the increase of the TTL, the size of the burr increases. The observed burr size values are plotted in Figure 6-12. Each twenty observations belong to one tool life stage. The means indicated in the chart signify the average value of the twenty observations, which are the representative of the burr size value for each tool wear level. The average size of the burr slightly increases.

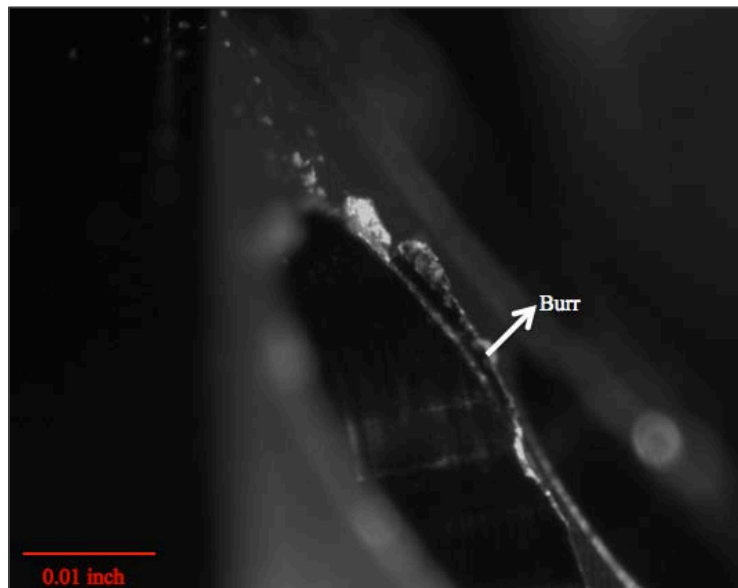

Figure 6-11: Burr on the edge of the holes after free cut

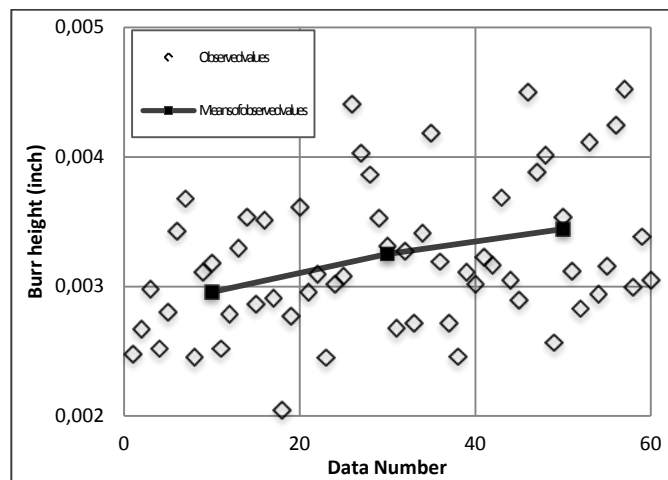

Figure 6-12: Observed burr height values (Part B)

In Table 6-3 one can see the summary results of ANOVA for part B. Based on the analysis p-value for both factors is less than 0.05. Thus, burr size level and operator are both statistically significant. The interaction between two parameters is not significant since the p-value is larger than 0.05. The percent contribution of each parameter is shown in the table. It can be observed that the percent contribution of burr size level is considerably reduced compared to the part A. This can be explained through the comparison of observed burr values for two parts. The burrs on part B are notably smaller than the burrs on part A. furthermore, the difference between the mean burr size of the levels is part A is larger. In other words, for part B, the average burr size values of the different tool wear stages are closer to each other. Thus the effect of tool wear is reduced.

One can find the graph of main effects in Figure 6-13 and Figure 6-14. The break edge slightly increases with tool wear. The break edge mean also varies per operator. It can be observed that the operators 2 and 3 create larger break edge than operator 1 and 4. The operators consulted about the process. They believed that the samples of different levels were identical in terms of difficulty of deburring. The operators did not mention any major difference in required applied force and operation time for deburring samples with different burr size levels. They also revealed that performing deburring process on part B was easier than the part A.

Since the burr variation range on this part is very small, the deburring results are more consistent. Furthermore, this part is more convenient for operators to deburr since they do not have to remove large burrs with additional force.

Table 6-3: Summary of ANOVA for break edge (Part B)

Factor	Degr. Of Freedom	Break edge (inch) SS	Break edge (inch) MS	Break edge (inch) F	Break edge (inch) P	Percent Contribution
Burr size level	2	7.39E-07	3.69E-07	5.271	0.008519	5.20
Operator	3	9.71E-06	3.24E-06	46.206	0.000000	68.43
Burr size level*Operator	6	3.79E-07	6.31E-08	0.901	0.502047	2.67
Error	48	3.36E-06	7.01E-08			23.70
Total	59	1.42E-05				100

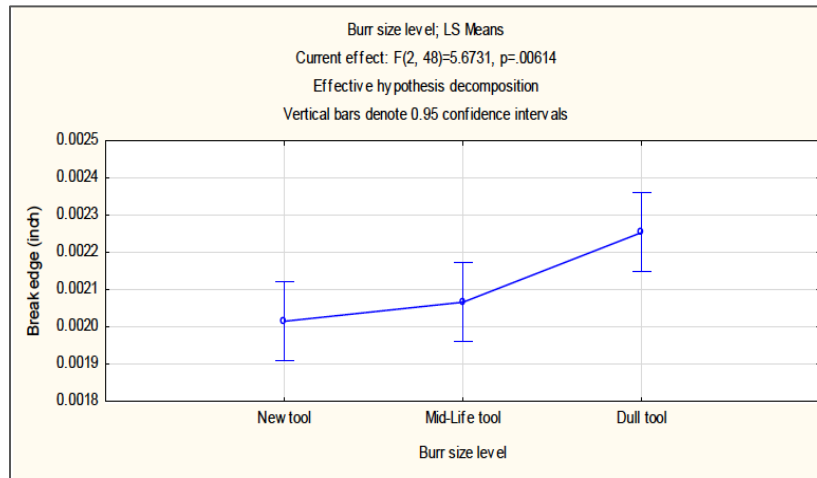

Figure 6-13: Effect of burr size level on break edge (Part B)

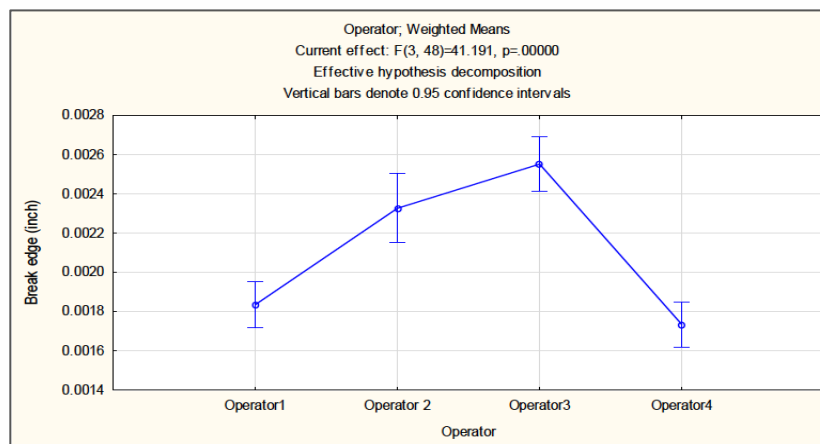

Figure 6-14: Effect of operator on break edge (Part B)

The effect of both parameters is shown in Figure 6-15. In comparison with part A the results are more close to each other. Less variation is observed in the means. It can be concluded that the deburring results of this part is more consistent. Except operator 4, the other operators created larger break edge for larger burr size. Operator 4 created smaller average break edge for medium size burr. It can also be seen that the range of break edge he created on the second level of burr size is wider than the other two levels.



Figure 6-15: Effect of burr size and operator on break edge (Part B)

Figure 6-16 represents the residuals. The model and the discussed results can be validated via investigating the residuals. The plotted residuals vs. predicted values do not follow a particular pattern. This proves that the observations are independent and the assumption of constant variance of residuals is accepted.

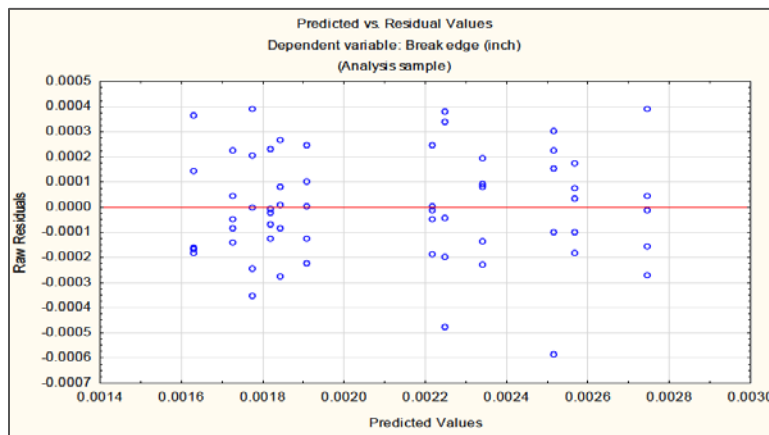

Figure 6-16: Residuals vs. predicted values (Part B)

6.2.3 Part C

The measurements and sampling of the part C was identical to part B. Part C is smaller than the part A and has geometrical characteristics resembling to part B. Due to small difference in their neck shape, the clearance of the free cut is 0.0005 inches which is 0.0001 larger than the one of part B. This small change causes difference in burr characteristics of two parts. One can see the observed burrs on the holes of the samples in Figure 6-17.

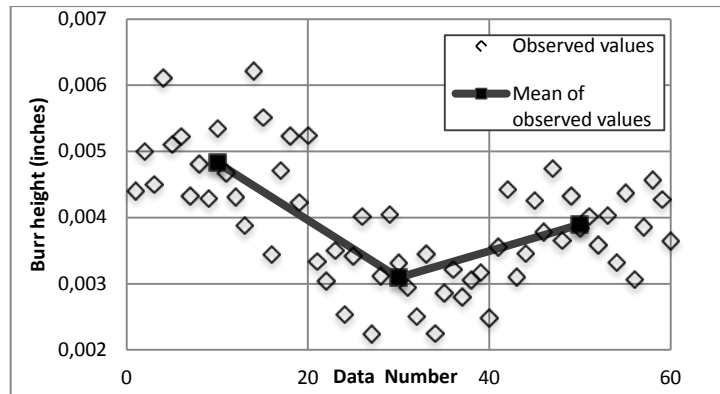

Figure 6-17: Observed Burr height values (Part C)

As part B, the burr was measured on twelve samples. Four parts from each tool life stage were collected. Five random holes of each part were selected to measure the burr on them. Each twenty observations show the observed burr heights in one tool life stage. The means indicated in the chart represent the average of the twenty observations of each tool wear level. It can be observed that unlike previous samples, the size of the burr is larger when the tool is new. It decreases in medium tool wear region and increases in last stage of tool wear. This can be attributed to free cut clearance. Before the free cut operation, the burr created by new tool is smaller than the burr in next tool life stages. If the clearance of free cut is not small enough to provide minimum chip thickness, the cutting action does not occur. The tool in free cut operation does not meet the minimum chip thickness required for cutting the small burrs created by new tool. In the next stages with increasing the tool wear the burr height grows which increase the contact length of the tool and the burr. Thus, the cutter can remove the larger burrs and consequently after the free cut operation, the burrs created in second and final stage of tool wear are smaller than those of first stage.

Table 6-4: Summary of ANOVA for break edge (Part C)

Factor	Degr. of Freedom	Break edge (inch) SS	Break edge (inch) MS	Break edge (inch) F	Break edge (inch) p	Percent Contribution
Burr size level	2	1.118E-06	5.59137E-07	5.133	0.010	6.121
Operator	3	1.129E-05	3.76338E-06	34.548	0.000	61.800
Burr size level*Operator	6	6.316E-07	1.05259E-07	0.966	0.458	3.457
Error	48	5.229E-06	1.08932E-07			28.621
Total	59	1.827E-05				100

Table 6-4 shows the ANOVA summary results for part C. P-value is smaller than 0.05 for burr size level and operator, which is interpreted as statistical significance of both parameters. Since the p-value is larger than 0.05 for the interaction, it can be concluded that the effect of interaction on break edge is negligible comparing to effect of each factor. The percent of contribution of each parameter can be observed in the table. Comparison the results of part B and part C, one can see the percent contribution values of main parameters well match each other. The corresponding observation can be attributed to geometrical resemblance of the parts as well as the similarity of their burr characteristics. With respect to measured burr height and ANOVA results it can be concluded that reducing the size of the burr decreases the percent contribution of the factor. The smaller the burr, the less variation between the levels is observed. Thus, controlling the burr size can decrease the variation of the result and so the inconsistency.

The main effects are plotted in Figure 6-18 and Figure 6-19. The main effect plots reveals that the burr size of new tool is larger as discussed. In decrease and then again it increase from mid-life tool to blunt tool. The operators produced different results. The mean break edge created by operator 3 is noticeably larger than of others.

One can see the effect of both parameters in Figure 6-20. All of operators created larger break edge in new tool stage. The results are more consistent in comparing to part A. The size of the break edge well match the average burr size of each tool life level.

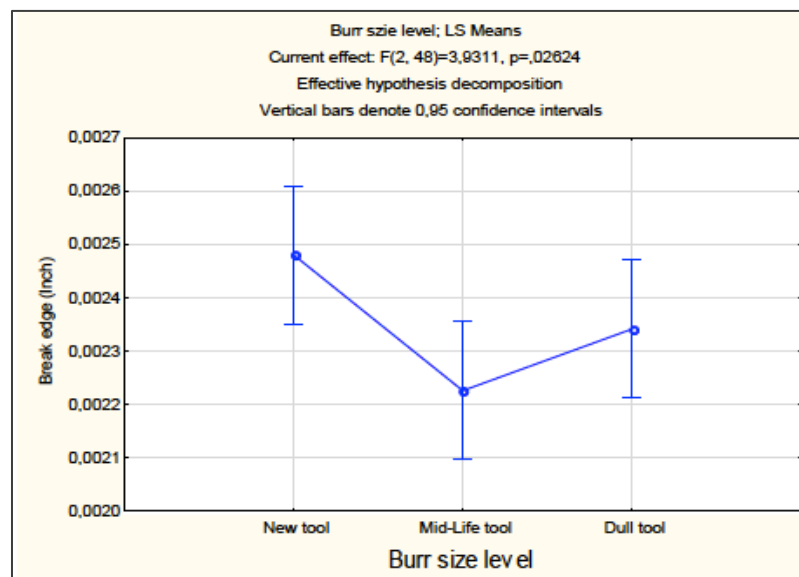

Figure 6-18: Effect of burr size level on break edge (Part C)

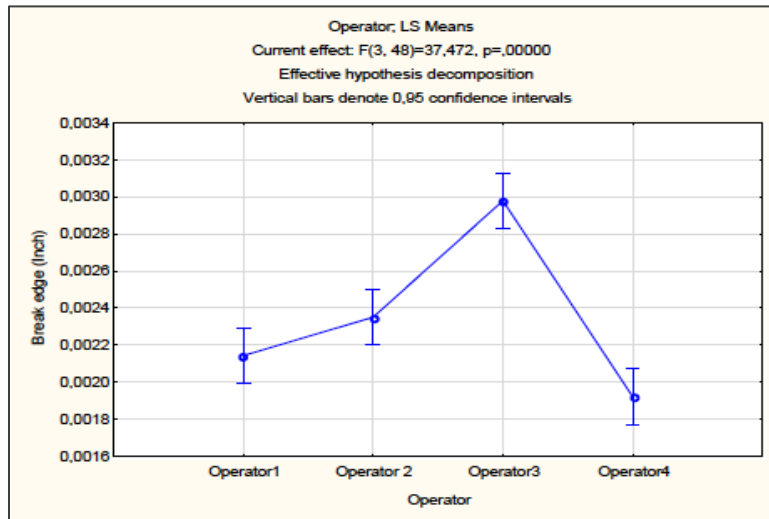

Figure 6-19: Effect of operator on break edge (Part C)

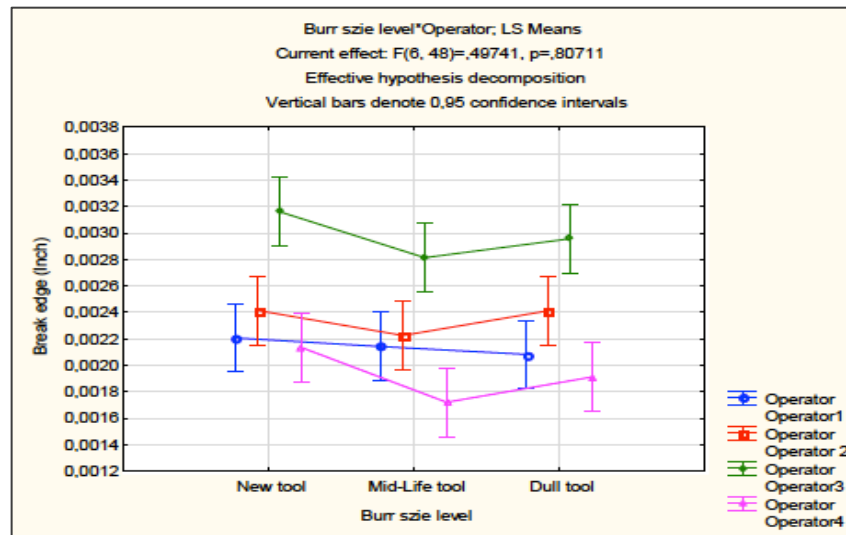

Figure 6-20 : Effect of burr size and operator on break edge (Part B)

One can see the effect of both parameters in Figure 6-20. All of operators created larger break edge in new tool stage. The results are more consistent in comparing to part A. The size of the break edge well match the average burr size of each tool life level.

In ANOVA analysis, the residuals plot can verify whether the primary statistical assumptions of were correct. Thus, it can be used as a validation for the results. The residuals are shown in Figure 6-21. Since no specific pattern is observed in the graph, the results are considered significant. Furthermore it verifies that the sampling was random and input data was reliable for statistical analysis.

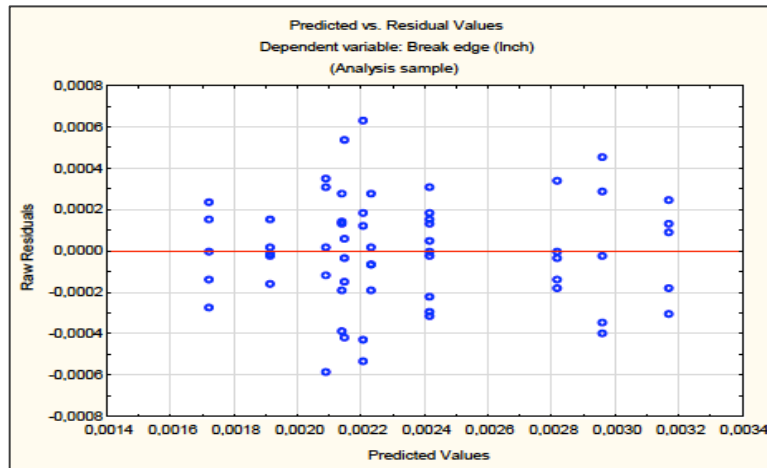

Figure 6-21: Residuals vs. predicted values (Part C)

6.2.4 Part D

The ANOVA summary results for part D can be observed in Table 6-5.

Table 6-5: Summary of ANOVA for break edge (Part D)

Factor	Degr. of	Break edge (inch) SS	Break edge (inch) MS	Break edge (inch) F	Break edge (inch) P	Percent Contribution
Burr size level	2	4.389E-07	2.194E-07	7.920	0.001065	14.64
Operator	3	1.122E-06	3.740E-07	13.498	0.000002	37.43
Burr size level*Operator	6	1.067E-07	1.779E-08	0.642	0.696038	3.56
Error	48	1.330E-06	2.771E-08			44.37
Total	59	2.998E-06				100

It can be observed that p-value for both parameters, the burr size level and operator, is smaller than 0.05. Thus both parameters are considered significant. However the percent contribution of operator is larger. In the case of part D the percent contribution of error, which represents the uncontrolled parameters, is larger than other parts. The fact can be attributed to very small size of the burrs on the part. Thus small changes in environment had larger effects on the manual operation results. This should be mentioned that the deburring result of part D shows less inconsistency compared to other parts.

The main effects are plotted in Figure 6-22, Figure 6-23, and Figure 6-24.

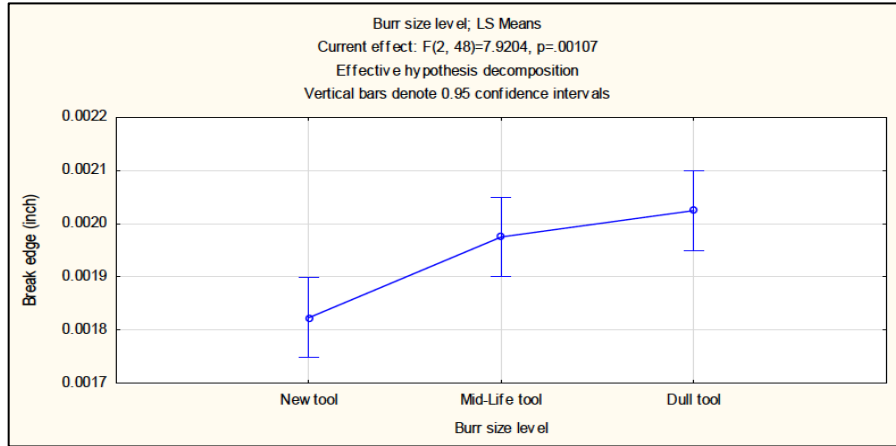

Figure 6-22: Effect of burr size level on break edge (Part D)

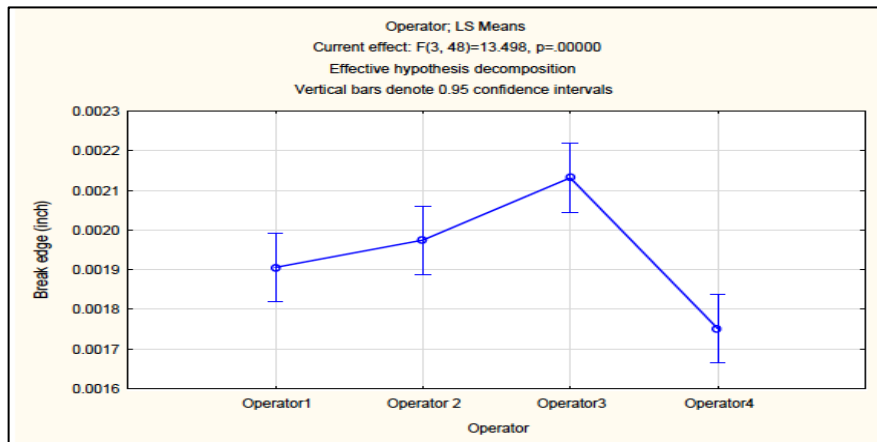

Figure 6-23: Effect of operator on break edge (Part D)

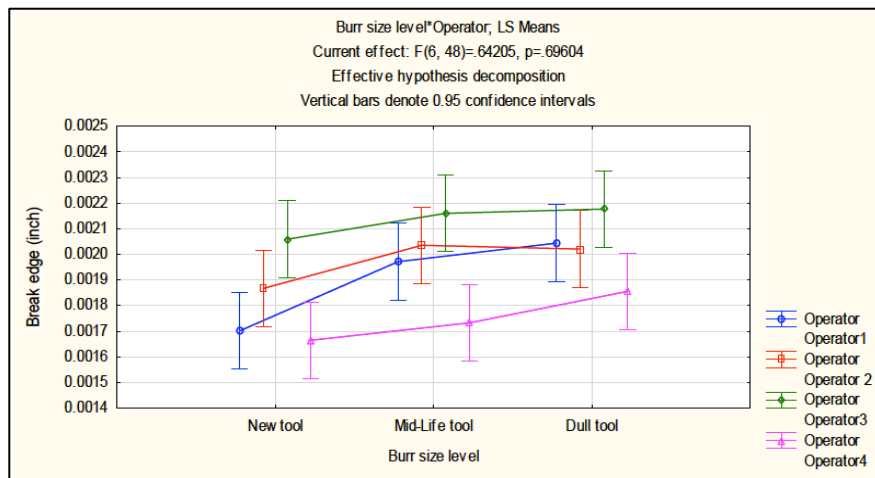

Figure 6-24: Effect of burr size and operator on break edge (Part D)

The mean points show that the average size of the break edge is corresponding in different levels of burr height. However, the mean break edge of new tool level is relatively smaller than the others. The residuals are shown in Figure 6-25. The residuals do not follow a specific pattern, which confirms the significance of the result and absence of systematic bias in the input data.

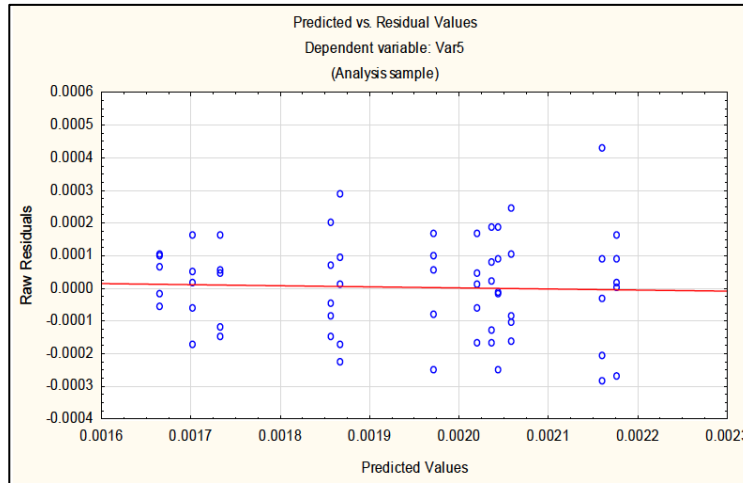

Figure 6-25: Residuals vs. predicted values (Part D)

6.3 Improvement Strategy

After assessing current state of the parts, a robust and reliable approach is needed to tackle the issue. The improvement strategies should consider the root causes of the phenomenon as well as the available equipment and the budget. Two different factors are identified as the source of inconsistency. The first factor, inconsistent burr size, can be interpreted as a manufacturing issue, whereas the second one, human error, is a post manufacturing matter, which is occurring on the quality line. Hence, each parameter needs to be treated individually. However, the final approach should be an inclusive strategy, which establishes a combination of feasible solutions to tackle both issues. The feasible solutions, which could ameliorate the results, are addressed in this section.

6.3.1 Modifying the burr size

As discussed in previous sections, the size of the burr increases with tool wear. The size and shape of the burr is considered as the input of the deburring process. Regardless of the manual or

automated deburring process, an inconsistent input can lead to inconsistent output. Furthermore the cost of deburring increase with the size of the burr and irregularity of burr profile[20].

Manual process can remove the burr with any level of inconsistency owing to the flexible nature process, although it creates inconsistent results due to human error. Automated processes usually are applicable for specific range of input that they are designed for. Most of them are not able to remove burrs over wide range of size and shape. Moreover, most of automated processes, which are proper to use for high production volume parts are not operating selective. They treat all features equally somehow they remove the same amount of material from all edges. Thus, irregularity of burr profile matters for these processes. The inconsistency of the burr size and irregular profile of the burr extremely restrict the choice of automated deburring process for the parts. Hence, the premier step toward the consistent deburring results is to modify the burr feature and supply the deburring process with a repeatable input. To aim the goal various options are available which are discussed further.

Figure 6-26 represents different approaches toward burr modification. Two general strategies could be followed. The first one is to remove the generated large burrs through the manufacturing process. The second one proposes methods to create small burr during manufacturing process.

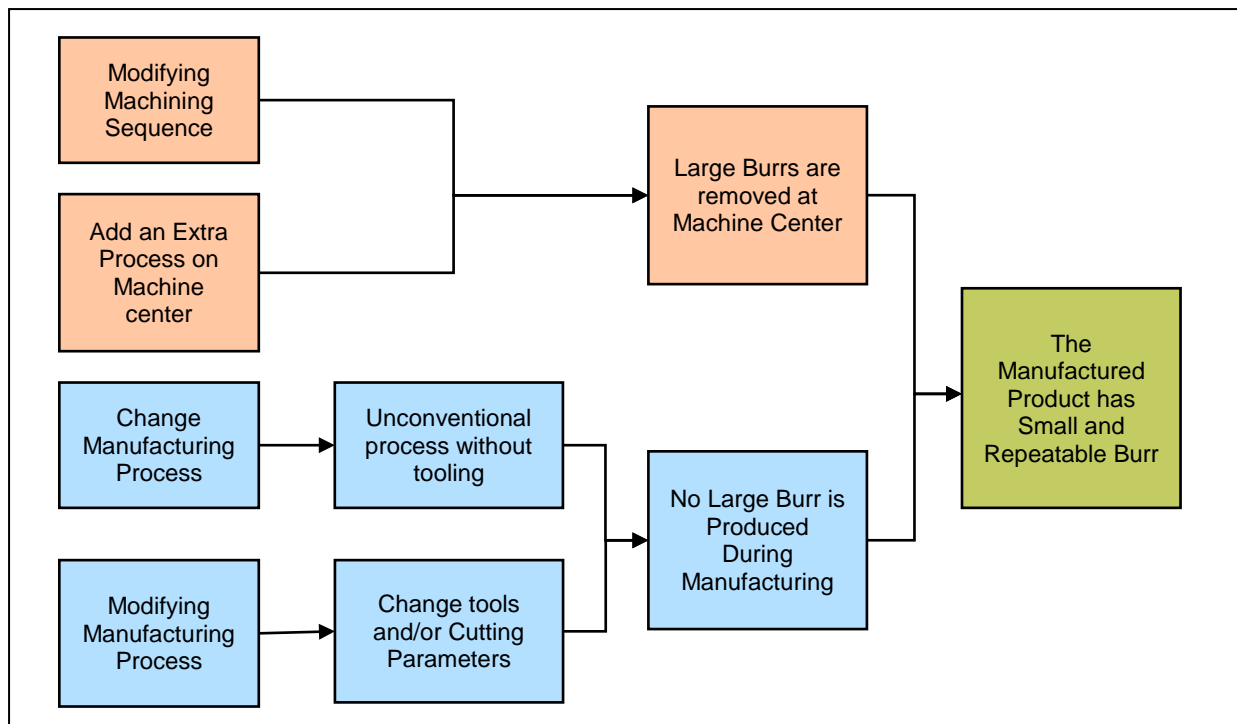

Figure 6-26: Producing small and repeatable burr

Machining sequence can be modified somehow the large burrs generated in previous operations, is removed through next operation. Apparently the burr will not be eliminated on all edges, but it can be placed in accessible areas. The process, which produce fewer burrs or create the burr on less critical edges, should be planned for last. For example, in the case of this study, the holes can be drilled before the surfacing operation. This strategy has some restrictions and drawbacks. The geometrical complexity of the part can extremely restrict the process planning options. Furthermore, creating profile on a surface with drilled holes that have burrs on them, can be considered as interrupted cutting, and can damage or break the tool. It should be mentioned that the surfacing process also creates burr on the holes edge, but the large and irregular drill caps are removed. This strategy has been already implemented at shop floor on part D. The premier profile was created on the surface, then the holes were produced, afterwards a finishing pass removed the burrs and created final profile on the surface. The burrs produced at final stage are bended into the holes and their sizes barely exceed 0.002 inches. Moreover, the ANOVA shows less variation of the results comparing to the other parts. Thus, this strategy can effectively reduce the variation of the deburring results. This approach is not applicable to other three due to geometrical limitations and tooling considerations.

Adding an extra operation to the manufacturing process is an effective technique to remove the large burrs on the workpiece and deliver parts with small burrs to deburring process. The technique is implemented on some parts as discussed. Free cut operation was employed to remove large burrs. The clearance was selected based on geometry of the part. The results were variable as discussed in previous sections. Large burrs are removed from the edges of the holes, but the small sawtooth shape burrs, which remain on the holes, have irregular profile around the periphery. This strategy is not applicable for part A, since the geometry of the part does not leave sufficient space for the tool to go back on the part and remove the large burrs.

Changing manufacturing process can prevent the formation of the burr. Various unconventional machining processes exist but there are certain limitations for using them, due to the thickness and also tight tolerances of the holes. For example, electrical discharge machining (EDM) can produce the holes with required tolerance, although, the material removal rate is very low. Thus, with respect to the thickness of the parts, the manufacturing time considerably increases. Moreover, the process leaves recast materials on the edges, which need to be removed. It also

creates heat affected zone, thermal stresses and micro cracks. Since the holes are very close to each other and the wall between the holes is very thin, the heat-affected zone in both sides of the holes may overlap and induce severe residual stress. In some parts it may even destroy the thin wall between the holes. Another example is laser drilling. Laser drilling have the same issue for the thin walls. It also creates taper shape. As the thickness increase the taper becomes more noticeable. Furthermore the laser drilling can hardly provide the required tolerance.

Modifying manufacturing process is a cost effective strategy, which can save hundreds of dollars on deburring process as it decrease the volume of the burr. The reduction of burr volume can be accomplished through changing the manufacturing tools and/or cutting parameters.

Some experimental studies have been previously performed at Pratt & Whitney Canada. Cutting parameters of the different parts have been optimized through various tests on the manufacturing line. Furthermore, edge chamfering end mills were employed to deburr the parts. The edge chamfering tools did not show the expected performance. The process induced excessive tool wear and chipping on the cutting edge. Some of the tools were broken during the tests. On the other hand, tool positioning was extremely challenging because the wear of index machine components over time decrease the accuracy of the machine. It should be mentioned that the exit burrs are placed on the profiled surface. Thus, the tool was not able to remove all the burrs around the periphery due to the curved profile of the surface and elliptical shape of the holes on it.

In this study, other strategies were implemented on part A after examining the parts and studying burr formation process. The descriptive results are presented in complementary experiments section.

6.3.2 Improvement of deburring process

The manual deburring process is involved with human factor. The process parameters are the applied force during operation, approach angle of the tool, and duration of the process, which all of them are dependent to the operator. Human error in one hand and natural difference between operators are two main sources of variation of the results. Various strategies, which can be offered to eliminate or decrease human error, are discussed further.

Figure 6-27 shows the general approaches toward reducing human error. The first approach is to modify the current manual operation. This approach can be beneficial since the complex geometry of the parts restricts the choice of an alternative process, which can perform the deburring action on all features. The main drawback of this approach is that the manpower is highly involved in the process although the process parameters are controlled by different techniques. Hence, probability of scraping the parts is still high due to human error. Furthermore, the production rate is still variable per operator.

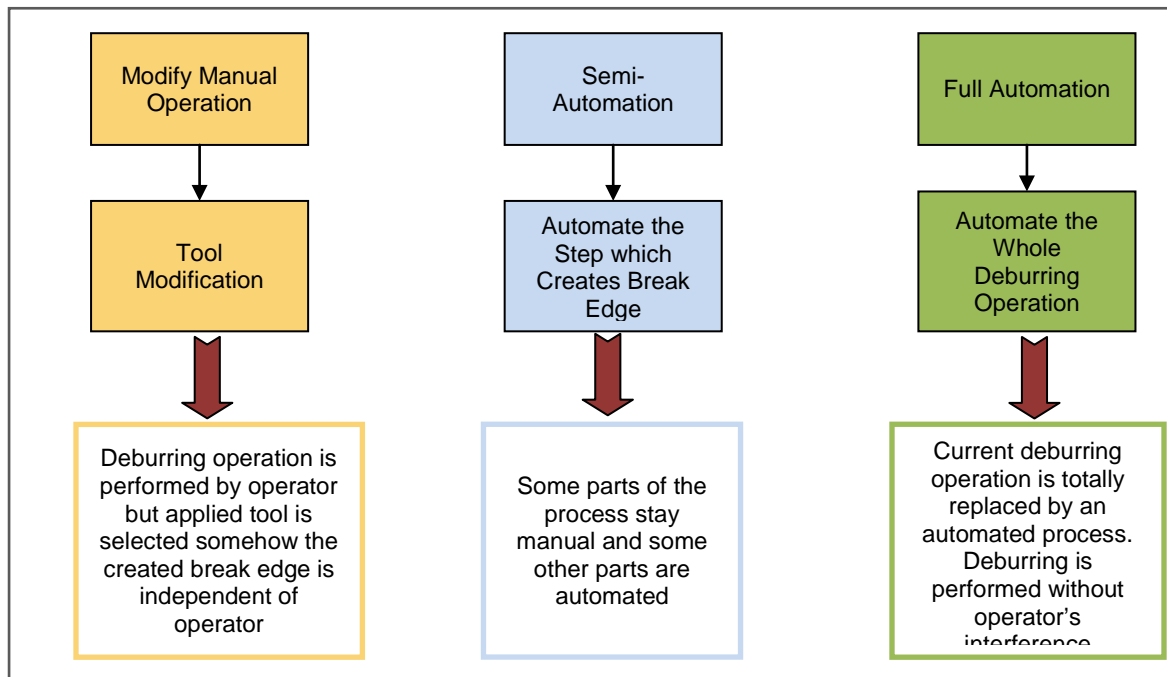

Figure 6-27: Reducing human error

As discussed before, in the current process, the operator uses a grinding wheel to remove large burrs. Then a round file is applied to create a small and wavy break edge, which the final break edge is highly dependent upon its size. Finally a buffing wheel is used to enlarge the break edge and polish the surface. An effective strategy to reduce human error is to provide the operators with more proper deburring tools. To produce consistent break edge, process parameters such as applied force, cycle time and approach angle should be controlled. To control the applied force during process, other sources rather than human should supply it. Motorized tools such as reciprocative handpieces can be used to deburr the parts as well as unconventional tools such as abrasive jets.

Figure 6-28 shows a reciprocating file. The reciprocating files are highly recommended choices since they restrict the force of operator. Thus, they can decrease both person-to-person and edge-to-edge variations. It also prevents the operator fatigue so more consistent result is expected. To control the approach angle a rubber tool guide can be employed. The guide is a hollow cylindrical shape rubber, which is installed on the handpiece head. The free end of rubber tube can be shaped as the parts surface. Then the operator positions the guide on each hole and removed the burr. This action restricts the specific approach angle that each operator uses to deburr the part.

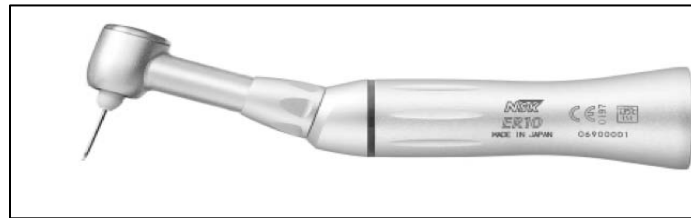

Figure 6-28: Reciprocating file (Courtesy NSK)

Abrasive hand jets are among the effective and very accurate hand deburring tools. The main drawbacks of these tools are pollutions because of micro abrasive particles and the high wear rate of the equipment.

Gillespie [20] offers two different approaches towards semi-automation. The first scenario is to prepare the parts manually, then use an automated process to create break edge and polish the surface. The preparation can be interpreted as removing large burrs around the part, removing the burrs from hard-to-access areas, or removing the burr from all edges without creating break edge. The second scenario is to deburr the parts with an automated process then use the manual operation to correct the imperfections of the previous process such as remaining burrs on hard-to-reach edges.

The full automation is another solution for inconsistency issue. One or several automated processes can be used to deburr and polish the parts. The alternative deburring processes, which are applicable to the air-swirlers, are listed in Table 6-6. The processes are compared based on different criteria.

Table 6-6: Alternative deburring processes

Process	Performance on Nickel alloys	High Production Volume	Equipment Maintenance	Precision	Initial Cost	Cycle Time
Abrasive Jet Deburring	◆	◆	High	■	Medium	Short
Electrical Discharge Deburring (EDM)	◆	■	Medium	⊙	High	Medium
Cryogenic Tumbling	⊙	■	Low	■	Medium	Short
Thermal Deburring	■	◆	Low	■	Low	Short
Burlytic Deburring	◆	■	Low	■	Low	Short
Laser Deburring	■	⊙	High	◆	High	Long
Centrifugal Barrel Tumbling	■	■	Medium	⊙	Low	Medium
Magnetic Abrasive Deburring	◆	■	Low	■	Low	Medium
Abrasive Flow Deburring	◆	⊙	High	◆	High	Medium
Robotic Deburring	◆	⊙	High	■	Medium	Medium

◆ Very Good ■ Good ⊙ Fair

Some of the processes above have been already tested at Part and Whitney Canada and the results are discussed further.

- Abrasive Jet Deburring:

Six different sizes of abrasive media were employed to deburr the parts. The process had negative effect on airflow of the parts. Edge rolling occurred at some entrances of the holes due to the plastic deformation. The results were not consistent during the tests. Thus, the process was reported to suffer from lack of repeatability.

- Burlytic Deburring:

Burlytic deburring was used to deburr and polish the parts. The variation of the parts features was of concern as well as the inconsistency of burr size and shape. Different cycle times were used for deburring both masked and without mask samples. With respect to the large burrs on the holes, no major difference was observed in the size of the burrs after the process. Since the process was not able to remove all the burrs, it was concluded that more cycle time or higher voltage is required which can affect the part dimension. Furthermore more complicated tooling was recommended if the process would be applied.

- Barrel Tumbling:

Different media size and cycle times were used to deburr the parts. The paste media was not able to completely remove the burr. Furthermore, the process significantly decreased the dimension of the parts. Since the parts should meet tight tolerance requirements, the abrasive media can scrap the part due to reducing the diameter and length of the parts. The process was reported to need more investigation and part preparation before the process.

It can be concluded that the last two processes had an issue in common which is inconsistency of burr size. The larger the burr the more cycle time is needed to deburr the part. Since both processes affect all the features of the part at same time, removing large burrs damage the dimension of the parts. Hence, producing small and regular burrs at machine center becomes more important while using mass finishing, electrochemical and all the processes with surrounding media.

In Table 6-6 other applicable processes are listed. The processes are extensively described in fifth chapter. In this section the advantages and disadvantages of each process is discussed based on the geometry, material and the requirements of air-swirlers. Some data in this section is collected through oral conversations and feasibility discussions with process specialists in different manufacturer companies.

- Electrical Discharge Deburring:

Using Electrical Discharge Machining (EDM) to deburr the air swirler holes can be a fast and effective way to remove the burr from the edges. The process has excellent performance on Nickel alloys. Since the volume of material removal is considered low it can be employed in high production applications. The main drawback of this process is that the process is not able to deburr all the features around the part. It can be employed to deburr the holes. Although it is very difficult to deburr the features around the part. The complex geometry of the parts can cause difficulties in implementing the process. Furthermore, the inconsistent shape and size of the burr can restrict deburring option using this process. Since the larger burrs need more sparks to be removed, irregular burr profile can damage the parts of the edge, which have smaller burrs. It should be mentioned that, the process could leave recast material and flashes on the edge. The process does not polish the surface. Thus, a polishing process is needed after the EDM. The

process can be beneficial in case of having consistent and regular burr. It can provide consistent break edge around the holes in a short time.

- Cryogenic Tumbling:

Cryogenic tumbling can deburr many parts in a very short time without affecting the dimension of the parts. The process is very consistent and the cost is very low. Moreover, the process is able to deburr internal features. This process has certain limitations for nickel alloys due to their high fracture toughness in low temperatures. On the other hand the process is not able to remove large and thick burrs, which can be an issue for air-swirlers. Though based on consultation with process engineers of NitroFreeze Company, some case studies have been successfully performed using liquid Helium for deburring nickel alloys.

- Thermal Deburring:

Thermal deburring is a process with very low cycle time, which can remove the burr on both internal and external edges. The process is able to deburr numerous parts at one time. The process can have certain limitations for deburring air-swirlers. The workpiece material is the first concern as the nickel alloys have poor heat distribution, which leads to partial deburring or no deburring action on the part. Furthermore the process is not able to remove thick and large burrs. Thus, it can be an issue for the parts with large burrs. It should be mentioned that the parts might need special cleaning process because of oxidized burrs on the surfaces.

- Abrasive Flow Deburring:

Abrasive flow is very precise process with excellent performance on nickel alloys. Although the equipment cost is high and the process can deburr a few parts simultaneously, it creates very consistent results for regular burrs. The process can be a good recommendation for further tests and studies owing to its flexibility on the burr size and the ability to remove burr from difficult to reach areas. Although the process not only is not able to remove the drill caps, but also, the presence of the drill caps can limit the deburring action and significantly affect the results. It should be mentioned that the process provides a fine surface finish all around the part.

- Robotic Deburring:

Robotic deburring can be employed to deburr the parts but certain consideration should be mentioned here. The small size of the parts and geometrical complexity of the features can restrict the robot access. Part holding is challenging since the pieces have curved profile all around. The parts have internal features, which are hard-to-reach for the robot. Considering the geometry and non-uniformity of the burr profile, using robots equipped to visual devices can increase the probability of success.

6.4 Complementary Experiments

After investigating the root causes and improvement approaches, complementary experiments were needed to evaluate the strategies. As discussed before, decreasing the size and profile discrepancy of the burr can effectively improve the consistency. Moreover, it is an important step toward the automation of deburring process. To aim the goal, the burr formation phenomenon was inclusively studied. Then different techniques employed to reduce the burr size and the results were compared to the results of current manufacturing process.

Among the applicable automated deburring processes, magnetic abrasive is selected considering the project budget and probability of success. The process is tested to deburr the parts with current burr size and also with prepared edge. This section will address the complementary tests with their results and discussions.

6.4.1 Burr Formation and Burr Minimization Strategies

Burr formation study is essential since it helps to choose an appropriate strategy to avoid large and irregular burrs. The study was conducted on the actual parts gathered during a manufacturing cycle. Then the tests were repeated to confirm the results of the investigations. Part A was the target of investigations as the observed burrs on its holes was significantly larger than the others. Part A has twenty-four holes around, which twelve of them are 0.01 inches smaller than the others. Same drill size is used to produce both holes. Then the holes are enlarged with different size of en mills. It should be mentioned that for manufacturing these part, two same drills of are mounted to two different tool holders somehow each creates twelve holes. The drills are changed after producing twelve parts. So each drill produce 144 holes before being changed. The large

and small end mills produce 12 and 18 parts before being changed. Figure 6-29 represents the holes and the tools, which produce them. The diameter of the two types of the holes has 0.01 inches difference.

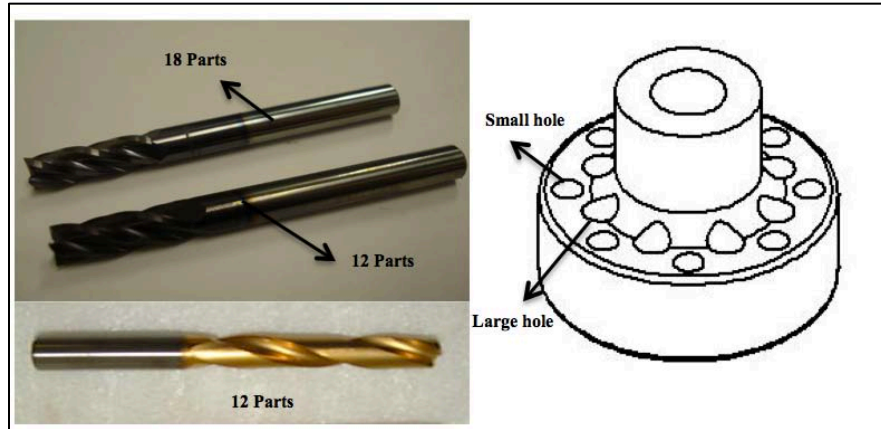

Figure 6-29: The part and the tools

Twelve parts were examined during the manufacturing cycle. All the tools were new at the beginning of the cycle. Burr height was measured on all the holes of each part. The large holes and the small holes were assessed individually.

6.4.1.1 Small holes

Small holes are placed near the periphery of the part. The exits of the holes cross the part of the surface, which does not have curvature. The burr is extremely large on these holes. Various types of burrs are observed on these parts depending on the tool wear and the temperature. These holes follow the specific burr formation pattern, which is discussed further.

The burr was measured on all the holes of each part. The burr height of each part represents the average of burr height value measured on twelve holes around the part. For example burr height of sample number 3 represents the average of burr height on its holes. In a continuous scale it also can be interpreted as the average burr height of hole number 24 to 36 that is produced by the tools. One can see the average burr height of each part in Figure 6-30.

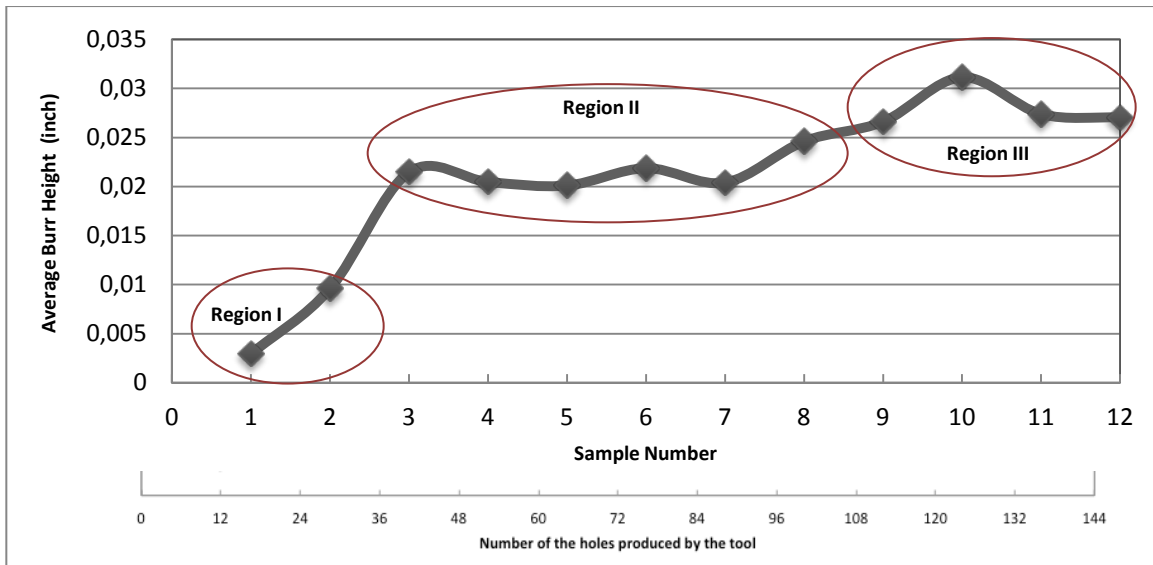

Figure 6-30: Average burr height of the parts and tool wear regions

The chart is divided to three main regions:

- Region I:

The burr is small and regular around the holes. No drill cap is observed on the holes. In this region the tool is new. The sharp tool induces lower cutting forces which leads to less material deformation. Thus, small and regular shape burrs are formed on the edges. One can see the burr of region I in

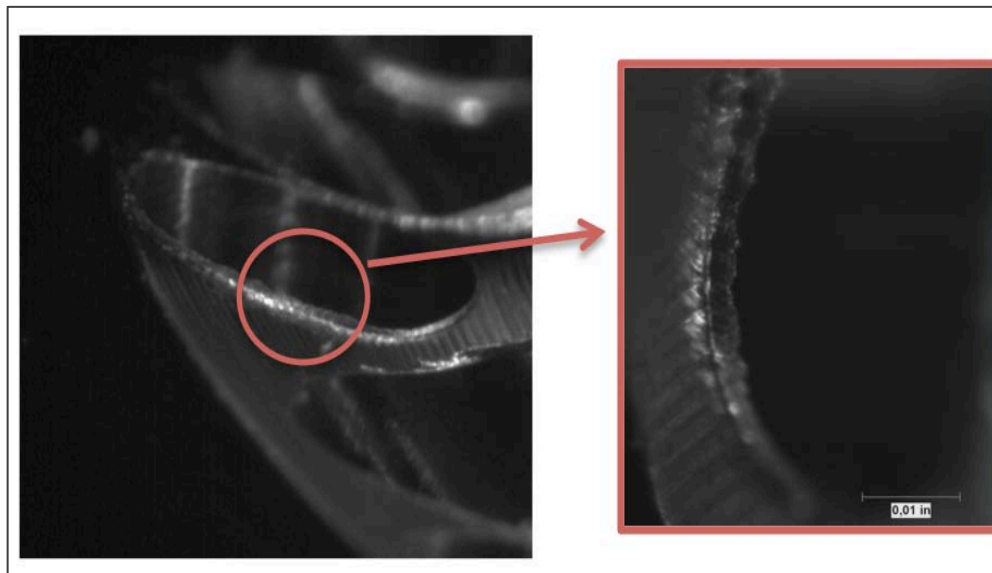

Figure 6-31: Small and regular burr in Region I

- Region II:

This region can be considered as steady state of burr formation since the average burr size remains approximately constant. The burrs observed in this area are mostly transient burrs. Incomplete drill caps are observed on some holes. However large regular burrs and crown burrs are observed on few holes. In this region a specific pattern is observed on the parts. On each part the profile of the burr starts from small burrs on the first drilled holes and end with large drill cap on the twelfth holes. Since the pattern is not observed on large holes, it cannot be address to bar stock properties or machine's stiffness. One can see the burr and the pattern on the parts in Figure 6-32.

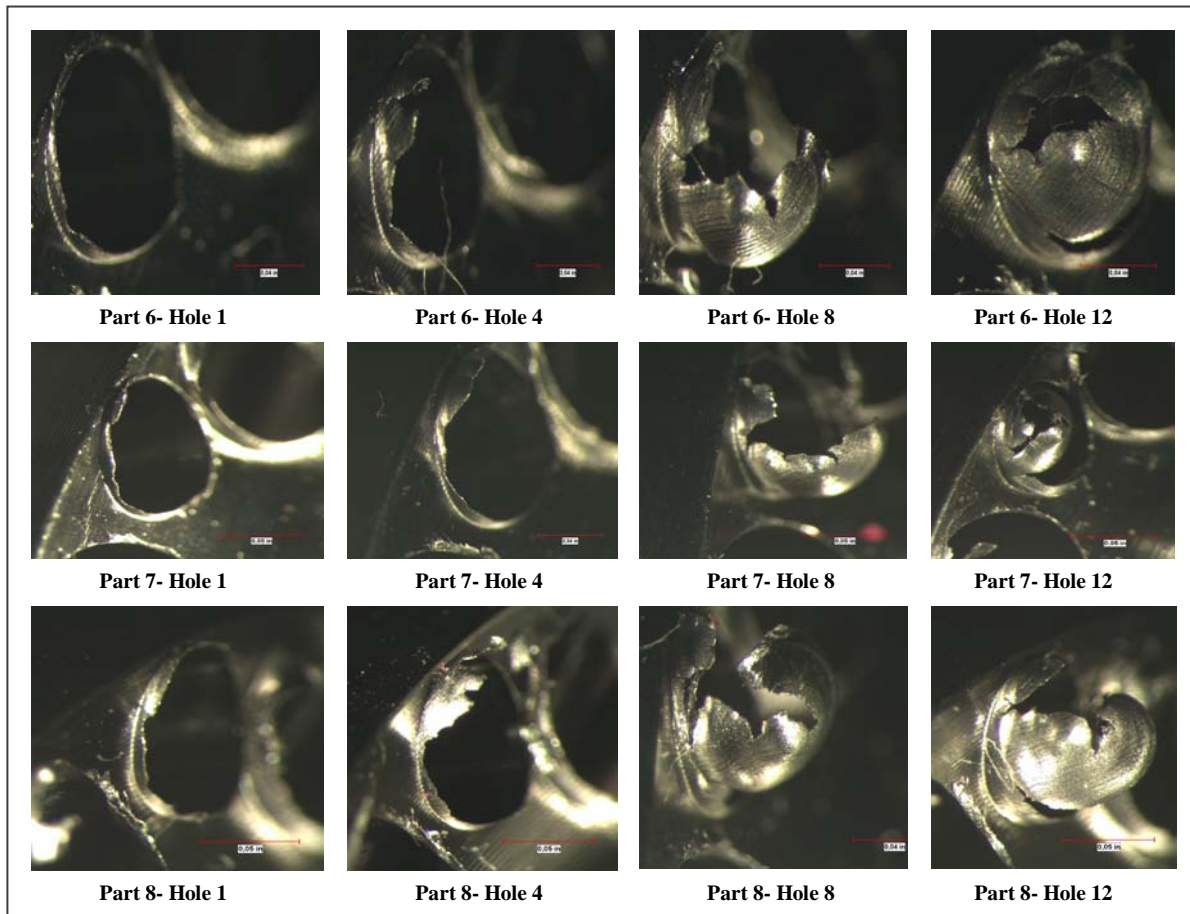

Figure 6-32: Burr formation pattern in Region II

It can be observed that on part 6 the tool creates small burr at the beginning. On the fourth hole large transient burrs are produced. The eighth hole has transient burr and a torn drill cap, which is severely stuck to the edge. The twelfth hole has very large but regular material projection with a

drill cap sticking on one side. The same pattern repeats for the next parts considering the fact that the drill and the end mill were not changed during manufacturing. Thus it can be concluded that the same tools created larger burrs as the cutting was continuously performed. The tools produced smaller burr after an interruption between manufacturing two parts. The examination of large holes revealed that it cannot happen due to repartition of material properties of the bar stock or machine stiffness. On the larger holes the burr height remains approximately constant around each part it follows no specific pattern. Furthermore, more samples were collected during next manufacturing cycles and the mentioned pattern was observed on almost all of them.

The pattern can be formed due to the temperature effect. The nickel-base alloys have low thermal diffusivity. Hence, the tool is subjected to the intense heat of cutting action. Since a comprehensive study is required to illustrate the matter, the temperature of the tool and the edges during production is measured via thermocouples attached to the part. Eight thermocouples were installed on the part before manufacturing the holes. The temperature of the tool and the edge was measured during the experiment. Each sensor recorded the temperature every 0.5 seconds. The experiment duration was 343 seconds. The recorded values are plotted in Figure 6-33.

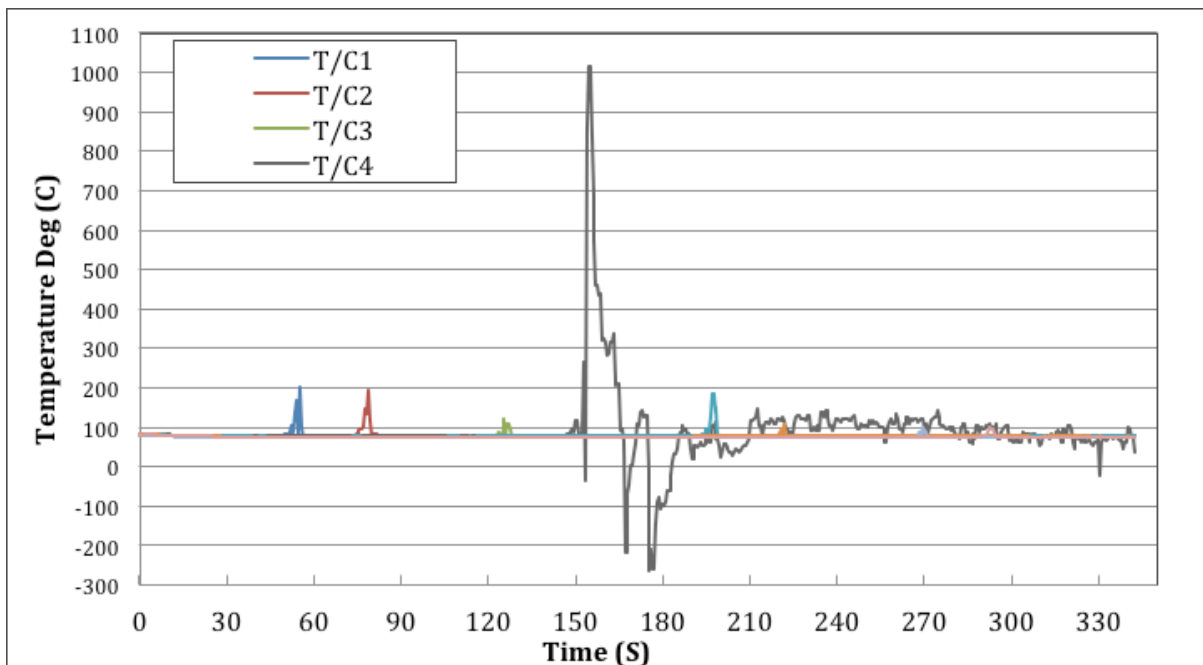

Figure 6-33: Temperature during cutting

Thermocouple 4 recorded the temperature of 1010°C for the tool tip while exiting the hole. Other thermocouples measured the temperature of the edge during cutting which the maximum recorded temperature was 204°C.

The elevated temperature in over time leads to diminution of elasticity modulus of the tool material and the coating [68]. The elastic modulus of Titanium and Aluminum ceramics extremely degrades at temperature around 1000°C [69].

The degradation of elastic modulus and elastic recovery are both time consuming processes. In region II the tool has passed the initial wear zone, which occurs at the beginning of cutting. The geometry of the tool is not considerably changed so it is able to perform the cutting action without excessive wear. As the tools starts to produce a hole, the temperature of the tool tip increases above 1000°C. Although high-pressure nozzles are used to provide the coolant, the flow is not able to reach to the end of the hole due to the geometry of the parts and the inclination and length of the holes. Thus, the tool tip extremely heats. The interval between producing two holes on a part is very short so the tool does not have enough time to decrease the temperature. Hence, for the next hole, the tool starts the cutting with higher initial temperature. On the other hand, the tool experiences the elevated temperature over the time, which leads to degradation of elastic modulus. This degradation causes a gradual elastic deformation on the cutting edges. Therefore, the tool, despite its unworn geometrical profile, operates like a blunt tool and start to create larger burrs as the cutting continues. This procedure is interrupted after producing twelve holes, as the workpiece is parted from the machine and the production of a new part is started. It this period the tool has enough time for elastic recovery. Thus it creates smaller burr on the first holes of the next producing part. This pattern repeats for the parts in region II.

- Region III:

In current manufacturing process, in region III, which is mentioned in Figure 6-30 most of the holes have large sever drill caps with transient irregular burr around them. No specific pattern is observed in this region and all the holes have catastrophic irregular material projections on their edges. The tool is significantly worn in this area so it creates larger burrs. Since the slope of the diagram rise, it can be concluded that the tool wear increases with higher rate. Figure 6-34 shows

the burr on three different holes of one part in region III. The pictures are taken from same angle so all of them show same section of the hole.

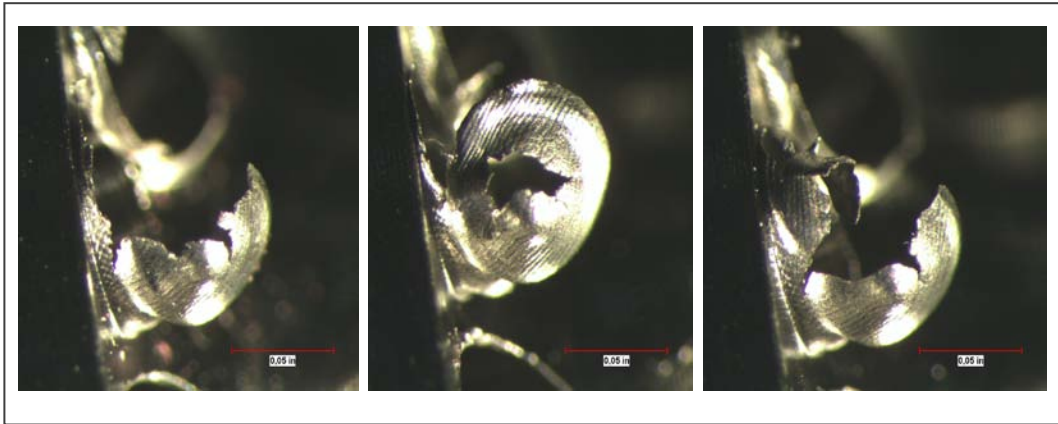

Figure 6-34: Burr on three different holes of one part in Region III

Various burr profiles can be seen on different holes of one part. All of them are large and irregular with severe drill caps, which need to be removed before the edge dressing process.

6.4.1.1.1 Burr Minimization Strategies

Two different strategies were applied to decrease the temperature of the cutting zone and the tool. The first one was using a coolant thru drill and the second one was changing the position of machine table from horizontal to vertical. The vertical position ameliorates the flow of the coolant through the holes. In this position the gravity and the inclination of the holes let the coolant reach all the cutting area and decrease the temperature.

The coolant thru drill is used to produce 12 parts at manufacturing line on the horizontal machine. All the other parameters and tools were remained constant during the test except the drill. The burr height was measured on all holes of each part and the average value is reported as burr height of the sample.

Second strategy was tested using the same drill, end mill, cutting parameters and workpiece thickness. The samples produced in vertical position. 144 holes were produced on the samples, which had same diameter and length as the parts at manufacturing line. The temperature of the tool tip was recorded via an infrared camera after producing each hole. The maximum value

recorded was 65°C. The burr height is measured on the holes and the average for each twelve holes is plotted in order to compare with current results of manufacturing line.

One can see the plotted burr height of the samples using both strategies and current process in Figure 6-35. The chart reveals that the burr height is effectively decreased when employing both strategies. A comparison between Figure 6-30 and Figure 6-35 shows that the height of the burr produced during vertical machining is in the same range of region I. The burr produced by coolant thru drill is slightly larger than the one produces via vertical machine. Although its height is still considerably smaller than the projections on current manufactured parts.

The common point of the three methods can be seen in Figure 6-35. The slope of the diagrams rises after producing 96 holes. In current study, regardless of production method, the growth rate of the burr height increases after removing certain volume of material by the tool.

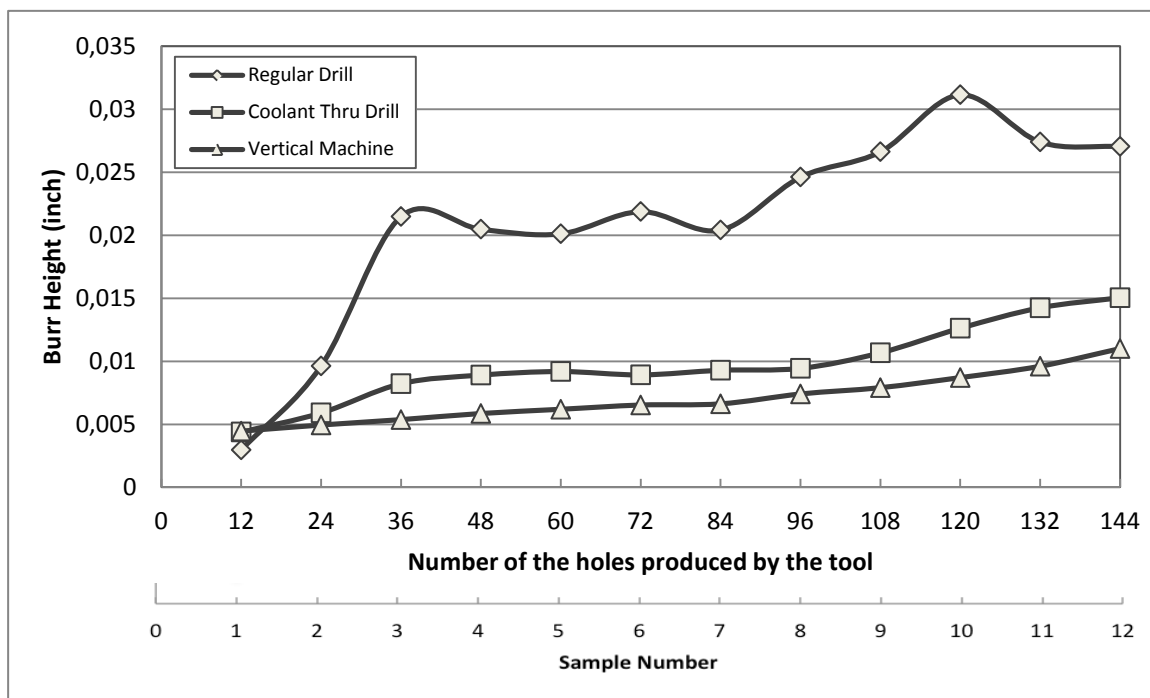

Figure 6-35: Burr height on the holes produced by different methods

The burr profiles on the test parts were studied. The burr formation pattern, which discussed before was not observed on the parts manufactured by the coolant thru drill and vertical machine. Moreover, the burr profile is very regular around the holes. The coolant thru drill and vertical machine both created drill caps after approximately 100 holes. The observed drill caps are complete caps lightly attached to the edge. The drill caps are loose somehow they can be easily

detached and removed by a finger or an air-blow gun. One can see the drill cap on the holes produced by each method in Figure 6-36. In order to present a meaningful comparison, holes (a) and (c) in this figure are chosen from the ninth produced sample and hole (b) represents the 102th hole produced on vertical position. Thus the tools had removed almost same volume of material when producing these holes.

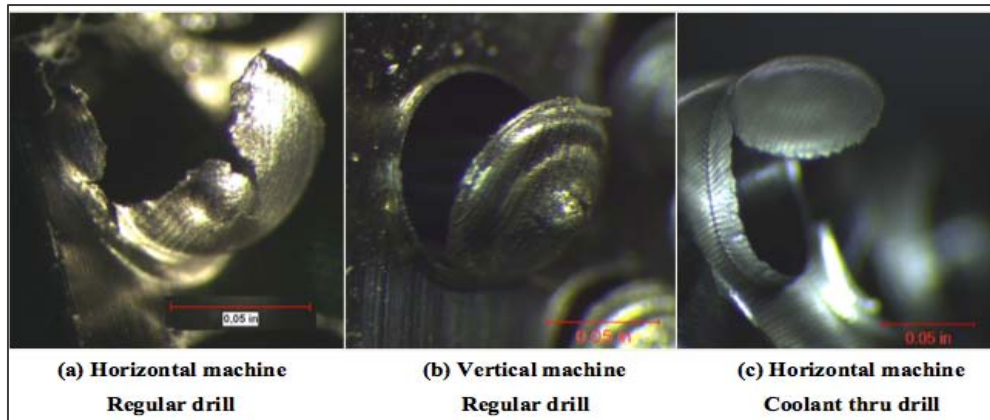

Figure 6-36: The drill caps created during current manufacturing process (a), vertical machining (b) and, using coolant thru drill (c)

The smallest burr produced via vertical machine. The burr profile is regular around the holes (b) and (c), although it is larger when coolant thru drill is used. The burr on hole (a) is very large with an interrupted profile around the hole. The incomplete drill cap is obstinately stuck to the edge of the hole.

Using both discussed strategies not only reduces the burr height significantly, but also, ameliorates the burr profile around the hole periphery. Hence, the consistency of the burrs produced during manufacturing can be improved by both methods. This can be advantageous in different aspects. These burrs are easier for operators to remove and suitable choice for automated processes. Furthermore, the results can be considered as a primary validation of the discussion about the effect of temperature on the burr size. However, more investigation and inclusive study on tool condition (wear, temperature, properties, geometry and etc.) is required, which is not included in scope of this study and is recommended for future researches.

6.4.1.2 Large holes

Large holes are placed near the neck of the part. The exits of the holes cross the curved surface. The burr observed on these holes can be classified from very small to relatively large in comparison to burrs created on small holes. These holes do not follow the specific burr formation pattern, which is discussed in previous section. The size of the burrs is variable on these holes and the burr profile is irregular around the periphery.

One can observe the burr on the large holes in Figure 6-37.

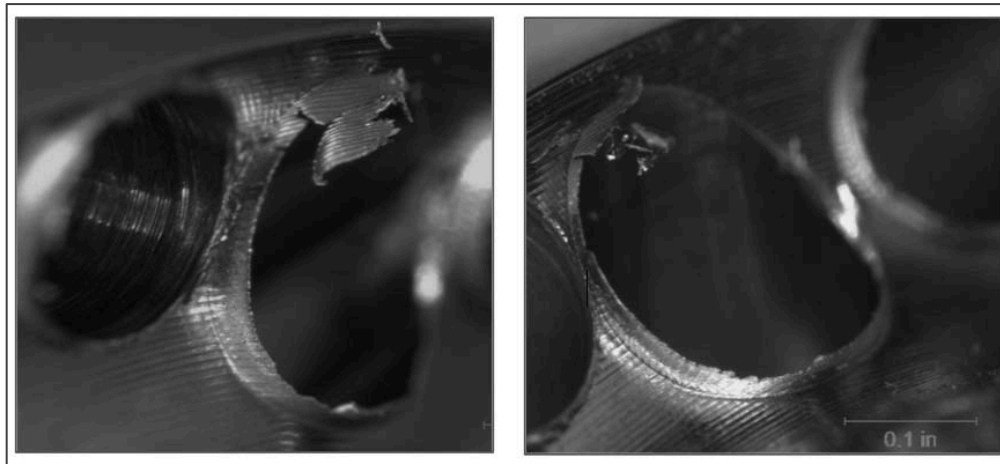

Figure 6-37: Burr on large holes

No drill caps were observed on the large holes. The height of the burr is considerably smaller than the small holes. Vertical machine was also used to produce the holes in samples. The technique effectively reduced the size of the burr. The burrs produced during vertical machining were small and regular around the periphery. The average burr height for each sample can be observed in Figure 6-38.

The reduction of burr height in vertical position can be attributed to the facilitated flow of the coolant through the holes. In horizontal position, the inclination of the holes leads the coolant to flow backwards and fail to reach the exit of the hole. In vertical position the natural direction of the flow (downwards due to the gravity) is aligned with the direction of the cut. Hence the cutting fluid wets the area decreasing the temperature and burr height subsequently. As the coolant flow can reach all around the inner surface of the hole, the uniform heat distribution is provided during cutting which leads to regular burr profile around the periphery.

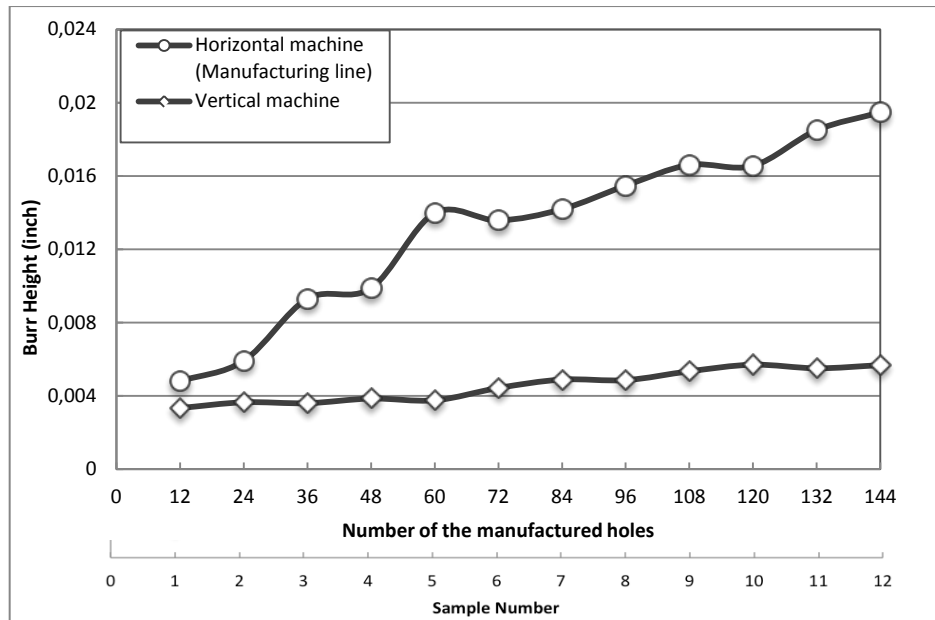

Figure 6-38: Burr height on the large holes produced in horizontal and vertical positions

6.4.1.3 Comparing the burr on small and large holes

As discussed in previous sections, two types of holes are produced through the parts. The holes of first group are 0.01 inch smaller in diameter. Comparison of the burr characteristics on two groups shows significant differences in size and shape of the burr on the edge of small and large holes. Since the size of drill is the same for both holes, the dissimilarity can be assigned to the end mill. During the experiments it has been observed that for identical tool life of the drill, sharper end mill created smaller burr. A sharp end mill can remove the drill caps created by a blunt drill.

The same drill produces both groups of the holes through the parts. In this study t_b and δ show thickness of the drilling burr and flank wear of end mill respectively. There is a critical value for δ in which, the end mill cannot remove the drilling burr. The value is called δ_c . the phenomenon happens when the diameter of the tool tip falls inside the diameter of the drilled hole. Thus δ_c is equal to difference between the diameters of the drill and the end mill. The value of δ_c is smaller for the small end mill. On the other hand the small end mill is more prone to edge chipping. As a result most of the small holes have large burrs and drill caps on them. Using a smaller drill to produce the small holes is proposed for further investigation as it can reduce the drilling burr.

6.4.2 Deburring and consistency

The burr minimization strategies were applied to reduce the burr volume and improve the burr profile. Then two types of experiments were conducted to assess the deburring options. First experiments were designed to investigate the effect of improved burr profile on manual operation and second experiments were conducted to evaluate Magnetic Abrasive Deburring process.

6.4.2.1 Manual operation

In this set of experiments 4 operators were asked to deburr three random samples each. The samples were produced by coolant thru drill. The measurements and randomization was based on the method discussed in previous sections. Then the inconsistency criteria described in methodology was used to compare the results. The results are derived for part A. One can see the three inconsistency criteria for both types of samples in Table 6-7.

It can be observed that inconsistency of manual deburring has been decreased for samples of coolant thru process. Decreasing of inconsistency is more significant for larger interval values. For regular drill samples the values of $\eta_{10\%}$, $\eta_{20\%}$ are approximately equal and $\eta_{30\%}$ is still more than 0.7. For coolant thru samples $\eta_{10\%}$, is larger than 0.7, which is smaller than the result of regular drill. The value of $\eta_{20\%}$ shows larger difference with previous results so that near 50% of observations are within 0.1M from centerline (mean or M). The value of $\eta_{30\%}$ is significantly decreased so only 18% of observations are more than 1.5M away from the mean (M). It can be concluded that regular burr profile improved the consistency of the results of manual operation.

Table 6-7: Inconsistency of measured break edge for samples from regular and coolant thru drill processes based on three main criteria

Inconsistency of break edge	Manual deburring of samples produced by Regular Drill	Manual deburring of samples produced by Coolant Through Drill
$\eta_{10\%}$	0.83	0.73
$\eta_{20\%}$	0.82	0.53
$\eta_{30\%}$	0.73	0.18

The operators were consulted about the manual operation difficulty. They believed that the burrs on coolant-thru-drilled samples required less force and repetition than the regular parts.

6.4.2.2 Magnetic Abrasive Deburring Test Results

In previous sections different strategies towards decreasing the burr volume and improving the burr profile were proposed and implemented. This section addresses the Magnetic Abrasive Deburring process as an alternative for manual operation. The experiments conducted with and without edge preparation before the test run.

The first set of experiments was run without preparing the samples. The experiments aimed to evaluate the performance of the process on the parts released from machine center. The results of these experiments could reveal if the process is able to deburr the parts produced through actual machining process (regular drill and horizontal machine) without an additional pre-or-post-deburring process. The samples with unprepared edges were selected from the parts produced in medium tool wear stage. Since the parts were selected from Region II of tool wear different types of burrs from small and regular projections to large attached drill caps could be observed on the holes. Three samples of each part were deburred using magnetic abrasive device. The tests were conducted based on Table 5-3 with three media sizes and 2 time cycles. One can see the holes before and after the process in Figure 6-39, Figure 6-40 and Figure 6-41.

The parts and burrs were measured before and after the process. The dimensions of the samples such as diameters (enternal and external) and workpiece length did not change after the process. Thus it can be said that the cycle time does not affect the geometry and dimension of the parts although, further research is required to investigate its effect on fatigue characteristics and the residual stress of the part.

Figure 6-39 shows three holes on part A. Although the non-deburred sample had large drill caps, no drill cap was observed on the holes after both 10 and 20 minutes time cycles. The size of the burr was reduced during the process however the burrs are not completely removed and no break edge observed on the holes of part A, which had large burrs.

Figure 6-40 and Figure 6-41 represent the state of the parts B and D. Rolled edge can be observed on around the periphery of the holes, which had slight burrs. Large burrs were shortened during the process, but they are not removed.

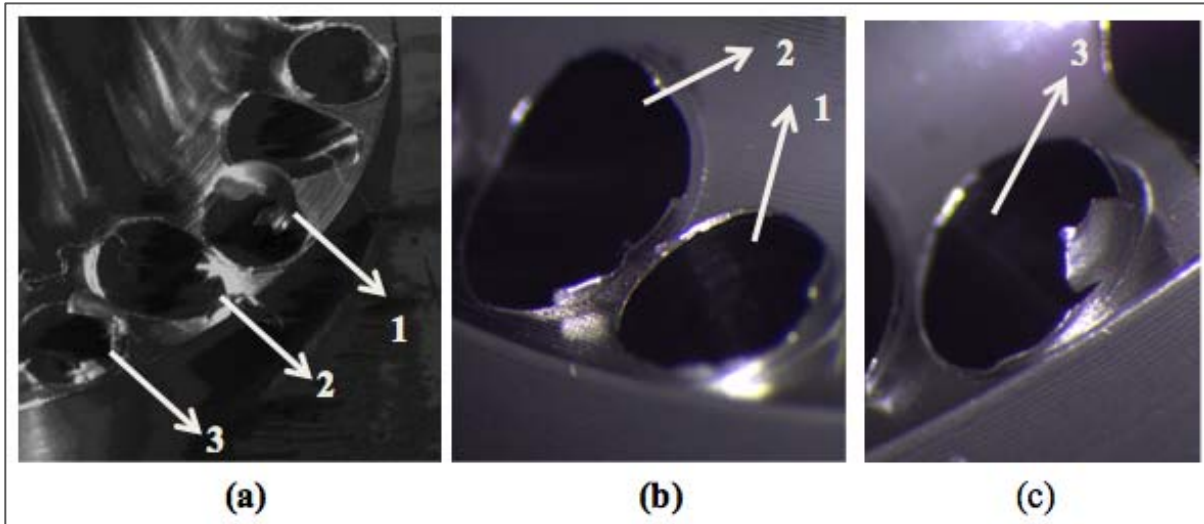

Figure 6-39: Burr on the holes of part A before (a) and after the process (b) and (c)

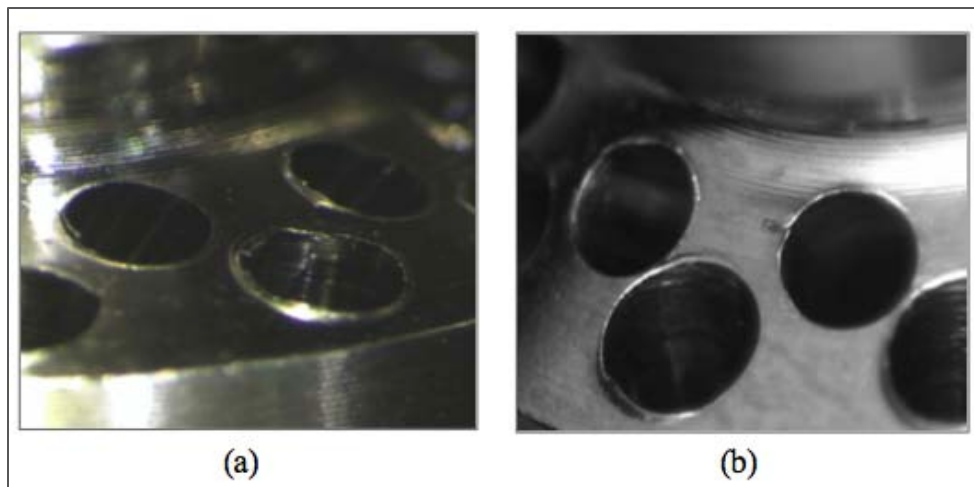

Figure 6-40: Burr on holes of part B before (a) and after the process (b)

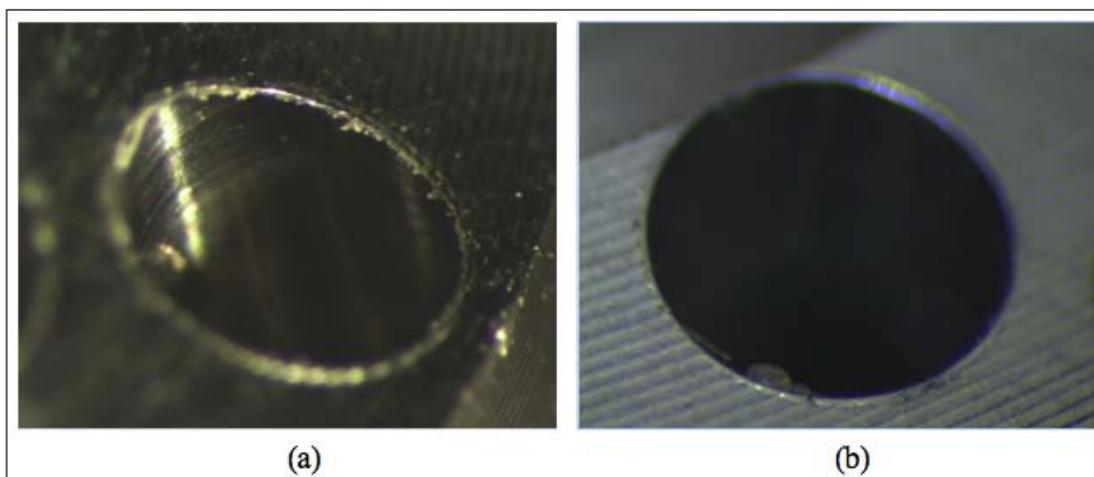

Figure 6-41: Burr on holes of part D before (a) and after the process (b)

The second set of experiments was run with prepared samples. The operators were asked to remove the burrs from the edges without creating break edge. The preparation time was approximately 20% of total manual deburring time. The operators believed that manual preparation was not difficult-to-perform for them since the repetitive filing action was not needed. The prepared samples had neither burrs nor break edge around the holes. The 20 minutes time cycle was selected for all samples, as it was more effective in previous test results. One can observe the results for part A in Figure 6-42.

Using sample with prepared edge improved the results. No rolled edge was observed on the parts. All the edges had small and uniform break edge around the hole periphery. The inspectors were consulted about the acceptability of the results. They believed the surface finish was acceptable and the break edge is consistent. In their point of view the edge characteristic and surface finish of the sample parts met the quality and standards requirement to pass the inspection. The process showed consistent results in hole-to-hole, part-to-part and profile around the periphery criteria.

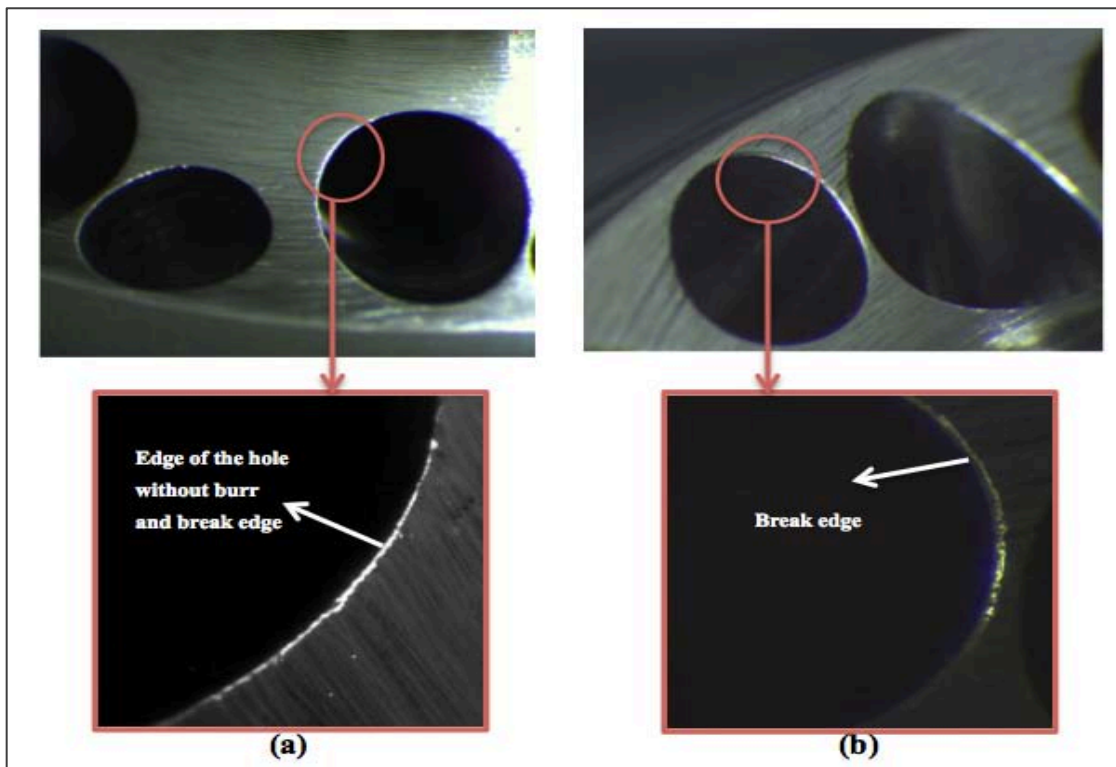

Figure 6-42: The prepared edge without burr and break edge (a) and the break edge around periphery after magnetic abrasive deburring (b)

One can see the deburring inconsistency values for different processes in Table 6-8.

Table 6-8: Inconsistency of measured break edge for manual and magnetic abrasive deburring

Inconsistency of break edge	Manual deburring of samples produced by Regular Drill	Manual deburring of samples produced by Coolant Through Drill	Magnetic Abrasive deburring of samples with edge preparation
$\eta_{10\%}$	0.83	0.73	0.45
$\eta_{20\%}$	0.82	0.53	0.15
$\eta_{30\%}$	0.73	0.18	0

The inconsistency significantly reduced comparing to the manual deburring results. The value of $\eta_{10\%}$, shows that 55% of observations fall between 0.05 of the average value of the results. In criterion of $\eta_{20\%}$ only 15% of observations are more than 0.1M away from the centerline (mean or M). The value of $\eta_{30\%}$ is 0, which shows none of observations are more than 1.5M away from the mean (M).

CONCLUSION

In this project the deburring consistency of air swirlers were improved. The parts were investigated and statistically analyzed. The root causes of the phenomenon have been defined. The weight factor has been assigned to each root cause. Then the improvement strategies have been implemented along with complementary experiments.

- **Root cause analysis revealed two main reasons of the inconsistency:**
 - Inconsistency of burr profile (shape and size)
 - Human error during manual operation
- **Based on root cause analysis The experiments were designed with two process factors:**
 - Tool wear in three levels (new, mid-life, blunt)
 - Operator in four levels (each bench operators is considered as a level for the factor)
- **The experiments were conducted on four different part numbers**
- **The collected data is analyzed using Analysis of Variance method. The ANOVA outcome included:**
 - The main effects plots
 - Significancy and percent contribution of each factor
 - Residual plots
- **Improvement strategies were selected with two main approaches:**
 - Burr control on machine center (burr minimization and profile improvement)
 - Using alternative deburring process
- **Complementary experiments were designed to implement the improvement strategies**
- **Through investigating the state of burr formation following results were obtained:**
 - Three main burr formation stages were identified through investigating the parts (Initial burr formation in region I, Steady state of burr formation in region II, and excessive burr formation in region III)
 - Cyclic burr formation pattern was observed in region II
 - The cutting temperature was measured via thermocouples and maximum recorded value was 1010°C.
- **The burr height and profile was improved with two approaches:**
 - Using coolant thru drill

- Using vertical position for the cut which ameliorates cooling action
- **Magnetic abrasive deburring process was evaluated in two conditions**
 - *Unprepared edges*, which the parts were processed directly after machining. Small burrs and rolled edges were observed on the parts after the process.
 - *Prepared edges*, which the parts had neither, burr nor break edge on them. Fine and consistent break edge was created through the process.

One can find the descriptive summery below:

Two main root causes were identified through the investigations. Burr characteristics (height, shape) from hole-to-hole and part-to part due to tool wear during manufacturing. Based on burr characteristics, the parts were classified in three main groups. Three main levels of tool wear were identified and each assigned to one group of parts: new tool, mid-life tool, and dull tool. The manual operation is another root cause. As a factor for experiments four levels were assigned to manual operation. Each individual operator is considered as a level for the factor.

The Taguchi experiments and ANOVA results revealed that the percent contribution of operators in producing inconsistent results was larger than that of burr size level. It was also observed that with decreasing the burr variation the percent contribution of burr size level significantly decrease. Though, the results were more consistent for the parts with smaller burrs.

The improvement approach was proposed based on root cause analysis. Complementary experiments were conducted in order to better understanding the phenomena as well as evaluating the strategies. Burr formation was investigated on Part A. Three main burr formation region were identified:

- **Region I:** The burr is small and regular around the holes periphery. No drill cap was observed on the holes. In this region the sharp tool induces small cutting forces, which leads to less deformation in material and small projections.
- **Region II:** In this region the average burr size remained in a certain range. Thus the region was considered as steady state of burr formation. Transient burrs and incomplete drill caps were the most observed in this region. However large regular burrs and crown burrs are observed on few holes. The burr formation follows a cyclic pattern in this stage. On each part, the profile of the burr starts from small burrs on the first drilled holes and

end with large drill cap on the twelfth holes. Thus it can be concluded that the same tools created larger burrs as the cutting was progressed. The tools produced smaller burrs after a time interval allowed between manufacturing of two parts. The pattern can be formed due to the temperature effect. The nickel-based alloys have low thermal diffusivity; hence, the tool is subjected to the intense heat of the cutting action. The temperature of cutting tool was measured via thermocouples. The temperature of 1010°C was recorded at the tool tip while exiting the hole. In region II the geometry of the tool is not considerably changed so it is able to perform the cutting action without excessive wear. As the tools starts to produce a hole, the temperature of the tool tip increases above 1000°C. The time interval between drilling two holes on a part is very short so the tool does not have enough time to decrease the temperature. The elevated temperature over time leads to degradation of elasticity modulus and micro-hardness and consequently a gradual elastic deformation on the cutting edge. Therefore, the tool, despite its unworn geometry, operates like a blunt tool. As the production procedure is stopped to part the workpiece from machine, the tool finds enough time for elastic recovery and creates small burr in first holes of the next part.

- **Region III:** In this region most of the holes have large severs drill caps with transient irregular burr around their periphery. The burr formation does not follow a specific pattern. Considering large and irregular burr around the hole it can be concluded that the tool is significantly worn in this area. Hence larger cutting forces applied to high toughness nickel alloy leads to large material projection.

The burr profile and volume were improved by two different techniques. Since the effect of temperature was observed in previous experiments, providing better cooling was proposed. Coolant thru drill was used to produce the holes through the parts. The burr height significantly decreased and burr profile improved. No transient burr and attached drill caps were observed on the parts. Homogenous cooling around the holes created uniform burr on the edges. The second approach was to manufacture the parts in vertical position. The vertical position facilitated the flow of the coolant through the holes. Since the inclination of the holes is aligned with the direction of gravity, the natural tendency of the cutting fluid stream is to flow through the hole. The samples produced in vertical position had small and regular burrs around their holes. The

height of the burr was smaller than both regular and coolant thru drills in horizontal position. The manual deburring results improved for the modified burr profiles.

Magnetic abrasive deburring is employed to deburr the parts. The experiments were conducted in two phases. The first phase was run on original parts without any treatment or preparation before the process. Some burrs were left on the edges with regard to initial size of the burr before the operation. Rolled edge was observed on holes with slight burrs. The second phase of experiments was conducted on prepared samples. The parts were prepared through a manual operation by operators. The large burrs were removed from the edges of the holes without creating break edge on them. Hence the parts were burr free with zero break edge before the operation. The parts had small and uniform break edge even on the holes with elliptical shape at the inclined exit surfaces. The results were very consistent from hole to hole and part to part. The surface finish met the quality requirements.

BIBLIOGRAPHY

- [1] N. Fricker and W. Leuckel, "CHARACTERISTICS OF SWIRL-STABILIZED NATURAL GAS FLAMES - 3. THE EFFECT OF SWIRL AND BURNER MOUTH GEOMETRY ON FLAME STABILITY," *J Inst Fuel*, vol. 49, pp. 152-158, 1976.
- [2] A. M. Mellor, *Design of Modern Gas Turbine Combustor*. London: Academic Press, 1990.
- [3] I. Treager, *Aircraft Gas Turbine Engine Technology*, 3 edition ed.: Career Education, 1995.
- [4] W. L. Mankins and S. Lamb, "Nickel and Nickel Alloys in Properties and Selection," in *ASM Handbook*. vol. 2, 10th ed, 1992, pp. 1363-1365.
- [5] E. O. Ezugwu, J. Bonney, and Y. Yamane, "An overview of the machinability of aeroengine alloys," *Journal of Materials Processing Technology*, vol. 134, pp. 233-253, 2003.
- [6] L. R. Hilbert, D. Bagge-Ravn, J. Kold, and L. Gram, "Influence of surface roughness of stainless steel on microbial adhesion and corrosion resistance," *International Biodeterioration & Biodegradation*, vol. 52, pp. 175-185, 2003.
- [7] D. Dornfeld, "Strategies for Preventing and Minimizing Burr Formation," presented at the Consortium on Deburring and Edge Finishing, University of California at Berkley, 2004.
- [8] D. A. Dornfeld, J. S. Kim, H. dechow, and L. J. Chen, "Drilling Burr Formation in Titanium Alloy, Ti-6Al-4V," *CIRP Annals - Manufacturing Technology*, vol. 48, pp. 73-76, 1999.
- [9] E. O. Ezugwu, Z. M. Wang, and A. R. Machado, "The machinability of nickel-based alloys: a review," *Journal of Materials Processing Technology*, vol. 86, pp. 1-16, 1998.
- [10] S. A. Sofronas, "The formation and control of drilling burr," Mechanical engineering department, University of Detroit, 1975.
- [11] J. C. Aurich, D. Dornfeld, P. J. Arrazola, V. Franke, L. Leitz, and S. Min, "Burrs, Analysis, control and removal," *CIRP Annals - Manufacturing Technology*, vol. 58, pp. 519-542, 2009.
- [12] D. D. S.L. Ko, "A study on burr formation mechanism," *Journal of Engineering materials and technology*, vol. 111, pp. 75-87, 1991.
- [13] S. H. Cheraghi, Twomey, J. M., Ksishnan, K., and B. Bahr, "An Automated System for Drill Bit Quality Determination," presented at the SAE General, Corporate and Regional Aviation Meeting and Exposition (GCRAM), Wichita, Kansas, 1999.
- [14] K. Jinsoo and D. A. Dornfeld, "Development of an analytical model for drilling burr formation in ductile materials," *Transactions of the ASME. Journal of Engineering Materials and Technology*, vol. 124, pp. 192-8, 2002.
- [15] L. K. Gillespie, *Deburring and Edge Finishing Handbook*. Dearborn, Michigan: Society of Manufacturing Engineers, 1999.
- [16] L. K. Gillespie, "Burrs produced by drilling," BDX-613-1248 United States Thu Mar 24 09:26:39 EDT 2011 Dep. NTIS ERA-02-005313; EDB-76-097103 English, 1976.
- [17] J. M. Stein and D. A. Dornfeld, "Burr Formation in Drilling Miniature Holes," *CIRP Annals - Manufacturing Technology*, vol. 46, pp. 63-66, 1997.
- [18] J. Kim, S. Min, and D. A. Dornfeld, "Optimization and control of drilling burr formation of AISI 304L and AISI 4118 based on drilling burr control charts," *International Journal of Machine Tools and Manufacture*, vol. 41, pp. 923-936, 2001.

- [19] S. Min, J. Kim, and D. A. Dornfeld, "Development of a drilling burr control chart for low alloy steel, AISI 4118," in *5th Asia Pacific Conference on Materials Processing, June 25, 2001 - June 25, 2001*, Seoul, Korea, Republic of, 2001, pp. 4-9.
- [20] L. Gillespie, *Hand Deburring: Increasing shop productivity*. Daerborn, Michigan: Society of Manufacturing Engineers (SME), 2003.
- [21] L. K. Gillespie, "The Battle of the Burr: New Strategies and New Tricks," *Manufacturing Engineering*, vol. 116, pp. 69-78, 1996.
- [22] R. B. William H. Cubberly, *Tool and Manufacturing Engineers Handbook* Desk edition ed. Dearborn, Michigan: Society of Manufacturing Engineers (SME), 1989.
- [23] F. Schäfer, *Entgraten Mainz*: Krausskopf-Verlag, 1975.
- [24] L. K. Gillespie and P. T. Blotter, "The Formation and Properties of Machining Burrs," *ASME Journal of Engineering for Industry*, pp. 66-74, 1976.
- [25] A. J. Pekelharing, "The Exit Failure in Interrupted Cutting," *CIRP Annals - Manufacturing Technology*, vol. 27, pp. 5-10, 1978.
- [26] M. Hashimura, J. Hassamontr, and D. A. Dornfeld, "Effect of in-plane exit angle and rake angles on burr height and thickness in face milling operation," *Journal of Manufacturing Science and Engineering, Transactions of the ASME*, vol. 121, pp. 13-19, 1999.
- [27] L. I. K. Gillespie, "Why we need standards for burrs," *Manufacturing Engineering* 1995.
- [28] K. Ohmori, "The movements of ISO 13715 as the only international standard for edge quality (EQ)," presented at the Proceeding of the 5th International Conference on Deburring and Surface Finishing, San Francisco, USA, 1998.
- [29] Y. Kato, "The standardized classification for edge quality of the precise machining products," presented at the Proceeding of the 5th International Conference on Deburring and Surface Finishing, San Francisco, USA, 1998.
- [30] K. Berger, "Proposal for a standard for the description of edges in automotive industry," presented at the Proceedings of the 7th International Conference on Deburring and Surface Finishing, 2004.
- [31] N. Ramachandran and N. Ramakrishnan, "A review of abrasive jet machining," *Journal of Materials Processing Technology*, vol. 39, pp. 21-31, 1993.
- [32] R. Balasubramaniam, J. Krishnan, and N. Ramakrishnan, "Investigation of AJM for deburring," *Journal of Materials Processing Technology*, vol. 79, pp. 52-58, 1998.
- [33] R. Balasubramaniam, J. Krishnan, and N. Ramakrishnan, "An experimental study on the abrasive jet deburring of cross-drilled holes," *Journal of Materials Processing Technology*, vol. 91, pp. 178-182, 1999.
- [34] R. Balasubramaniam, J. Krishnan, and N. Ramakrishnan, "An empirical study on the generation of an edge radius in abrasive jet external deburring (AJED)," *Journal of Materials Processing Technology*, vol. 99, pp. 49-53, 2000.
- [35] K. P. PRADHAN, "DESIGN AND FABRICATION OF ABRASIVE JET MACHINE," B.Tech, Department of Mechanical Engineering, National Institute of Technology, Rourkela, 2009.
- [36] I.-H. Choi and J.-D. Kim, "A study of the characteristics of the electrochemical deburring of a governor-shaft cross hole," *Journal of Materials Processing Technology*, vol. 75, pp. 198-203, 1998.
- [37] S. Sarkar, S. Mitra, and B. Bhattacharyya, "Mathematical modeling for controlled electrochemical deburring (ECD)," *Journal of Materials Processing Technology*, vol. 147, pp. 241-246, 2004.

- [38] J. B. Koroskenyi, "Burlytic Deburring-A new approach in Electrochemical Deburring," presented at the Deburring and Surface Conditioning, Orlando, Florida, 1995.
- [39] L. K. Gillespie, *Mass Finishing Handbook*, Illustrated ed.: Industrial Press, Incorporated, 2006.
- [40] M. J. Little, "Cool technology," *Products Finishing (Cincinnati)*, vol. 69, pp. 54-56, 2005.
- [41] I. Cryogenic Institute of New England, "Cryogenic Deburring For Machined Parts."
- [42] M. Gignac, "State-of-the-art cryogenic deflashing machine reduces cycle time and operational costs," *Rubber World*, vol. 227, pp. 20-21, 2002.
- [43] R. A. Sonogo, "Advances in TEM technology," Publ by SME, Dearborn, MI, United States 1993.
- [44] . *Thermal Energy Deburring*. Available:
<http://claymore.engineer.gvsu.edu/~rutgersj/reas.html>
- [45] R. A. Lindberg, "Processes and Materials of Manufacture," I. Allyn and Bacon, Ed., Second Edition ed, 1997.
- [46] J. Brown, "Modern Manufacturing Processes," I. P. Inc., Ed., First Edition ed, 1991.
- [47] D. G. K. a. K. H. Schwarz, "Thermal Energy Deburring," Society of Manufacturing Engineers (SME), Dearborn, Michigan 1991.
- [48] T. Mori, K. Hirota, and Y. Kawashima, "Clarification of magnetic abrasive finishing mechanism," *Journal of Materials Processing Technology*, vol. 143-144, pp. 682-686, 2003.
- [49] D. K. Singh, V. K. Jain, and V. Raghuram, "Parametric study of magnetic abrasive finishing process," *Journal of Materials Processing Technology*, vol. 149, pp. 22-29, 2004.
- [50] Y.M. Baron, "Technology of abrasive finishing in the magnetic field," presented at the Mashinostroenie, Leningrad, 1975.
- [51] Y. M. Baron, S. L. Ko, and J. I. Park, "Characterization of the magnetic abrasive finishing method and its application to deburring," *Key Engineering Materials*, vol. 291-292, pp. 291-296, 2005.
- [52] J.-S. Kwak, "Enhanced magnetic abrasive polishing of non-ferrous metals utilizing a permanent magnet," *International Journal of Machine Tools and Manufacture*, vol. 49, pp. 613-618, 2009.
- [53] S. Yin and T. Shinmura, "A comparative study: polishing characteristics and its mechanisms of three vibration modes in vibration-assisted magnetic abrasive polishing," *International Journal of Machine Tools and Manufacture*, vol. 44, pp. 383-390, 2004.
- [54] D. Korn. Deburr Small Parts With Swarming Stainless Pins Available:
http://www.earthchain.com/case-studies/MMS_2005/0905rt1.html
- [55] E. E. Corwin. Shake, Rattle & Roll. Available:
<http://www.gessweincanada.com/cometest/Gesswein PDF/Tumbling.pdf>
- [56] P. L. Gale, "Method of deburring Intersecting drilled holes," United State of America Patent, 1978.
- [57] L. K. Gillespie, "Laser Deburring: An overview for precision Edge Needs," Society of Manufacturing Engineers, Dearborn, Michigan 2011.
- [58] M. Gower, "Excimer laser microfabrication and micromachining," in *1st SPIE Int'l Symposium on Laser Precision Microfabrication*, 2000, pp. 124-131.
- [59] Nunobiki, Masayuki, K. Okuda, Yosuke, and Kitsugi, "Study on on-machine deburring for narrow slits made by laser cutting," *Advanced Materials Research*, vol. 76-78, pp. 306-312, 2009.

- [60] S. H. Lee and D. A. Dornfeld, "Analysis of precision deburring using a laser," Engineering Systems Research Center, University of California-Berkeley, Berkeley, CA1996.
- [61] S. H. Lee and D. A. Dornfeld, " Precision laser deburring," *Transactions of ASME, J. Manufacturing Science and Engineering*, vol. 123, pp. 601-608, 2001.
- [62] S. H. Lee and D. A. Dornfeld, "Precision laser deburring and acoustic emission feedback," *Transactions of ASME, J. Manufacturing Science and Engineering*, vol. 123, pp. 356-365, 2001.
- [63] G. S. Peace, *Taguchi methods: A hand on approach*. Massachusetts: Addison-Wesley Publishing Company, 1992.
- [64] "Design of Experiments," in *Home Builder's Guide to Continuous Improvement*, ed: CRC Press, 2009, pp. 171-188.
- [65] R. Jack, "Design of Experiments," in *Manufacturing Handbook of Best Practices*, ed: CRC Press, 2001.
- [66] M. Rausand, A. Høyland, "System Analysis, Fault Tree Analysis," in *System Reliability Theory; Models, Statistical Methods and Applications*, M. Rausand, Ed., Second Edition ed New York: Wiley, 2004.
- [67] "Introduction to Taguchi and Parameter Design," in *Six Sigma and Beyond*, ed: CRC Press, 2002, pp. 283-305.
- [68] G. S. Fox-Rabinovich, B. D. Beake, J. L. Endrino, S. C. Veldhuis, R. Parkinson, L. S. Shuster, and M. S. Migranov, "Effect of mechanical properties measured at room and elevated temperatures on the wear resistance of cutting tools with TiAlN and AlCrN coatings," *Surface and Coatings Technology*, vol. 200, pp. 5738-5742, 2006.
- [69] Y. W. Bao and Y. C. Zhou, "Evaluating high-temperature modulus and elastic recovery of Ti₃SiC₂ and Ti₃AlC₂ ceramics," *Materials Letters*, vol. 57, pp. 4018-4022, 2003.