

THE EFFECT OF THE BALLOONSAT PROJECT ON MIDDLE AND HIGH  
SCHOOL STUDENTS' ATTITUDE TOWARD SCIENCE

By

Copyright 2012  
L. Paul Verhage

Submitted to the graduate degree program in Department of Curriculum and Teaching  
and the Graduate Faculty of the University of Kansas in partial fulfillment of the  
requirements for the degree of Doctor of Philosophy.

---

Dr. James Ellis, Chairperson

---

Dr. Ronald Aust

---

Dr. Douglas Huffman

---

Dr. Phillip McKnight

---

Dr. William Skorupski

Date Defended \_\_\_\_\_

The Dissertation Committee for L. Paul Verhage

certifies that this is the approved version of the following dissertation:

THE EFFECT OF THE BALLOONSAT PROJECT ON MIDDLE AND HIGH  
SCHOOL STUDENTS' ATTITUDE TOWARD SCIENCE

---

Dr. James Ellis, Chairperson

---

Dr. Ronald Aust

---

Dr. Douglas Huffman

---

Dr. Phillip McKnight

---

Dr. William Skorupski

Date approved \_\_\_\_\_

## TABLE OF CONTENTS

ABSTRACT .....	viii
ACKNOWLEDGMENTS .....	ix
LIST OF TABLES .....	x
LIST OF FIGURES .....	xi
CHAPTER I .....	1
INTRODUCTION .....	1
Significance of the Study .....	1
The Global STEM Workforce .....	2
Student Attitude toward Science .....	5
Teaching to Address Attitude toward Science .....	6
Robotics and BalloonSats as STEM-Teaching Tools .....	9
Personal Interest in the Topic .....	12
Problem Statement .....	12
Primary Research Question .....	13
Secondary Research Question .....	14
Definition of Variables .....	14
Assumptions .....	15
Summary .....	16
CHAPTER II .....	17
REVIEW OF THE LITERATURE .....	17

Changes in STEM-related Industry and the Workforce .....	18
Industrial and Governmental Response .....	19
Teaching STEM .....	22
Engagement .....	34
Attitude .....	35
Measures of Science Attitude .....	38
Two Attitude Instruments .....	39
Robotics .....	42
BalloonSats .....	46
Summary .....	52
CHAPTER III .....	54
METHODS .....	54
Primary Research Question .....	55
Definition of Variables .....	55
Secondary Research Question .....	56
Power Analysis .....	56
Definition of Participating Schools .....	57
Research Locations .....	60
Research Time Period .....	61
Survey Sampling .....	63
Survey Participants .....	67
Procedures .....	68

Quantitative Study .....	69
Qualitative Study .....	77
Conclusion .....	79
CHAPTER IV .....	81
RESULTS .....	81
Research Design .....	81
Sample Characteristics .....	82
Research Question #1 .....	87
Research Question #2 .....	88
Research Question #3 .....	89
Research Question #4 .....	90
Research Question #5 .....	91
Research Question #6 .....	91
Research Question #7 .....	92
Analysis of Secondary Research Question .....	93
Secondary Research Question .....	93
Summary of Results .....	94
CHAPTER V .....	97
DISCUSSION .....	97
Research Question #1 .....	98
Research Question #2 .....	100

Research Question #3 .....	102
Research Question #4 .....	104
Research Question #5 .....	106
Research Question #6 .....	108
Research Question #7 .....	110
Secondary Research Question .....	111
Limitations .....	112
Summary .....	114
Recommendations for Future Study .....	117
REFERENCES .....	121
APPENDICES .....	135
A. Test of Science Related Attitudes (TOSRA) .....	136
B. Scale Allocation and Item Scoring .....	142
C. Focus Group Meeting Protocol and Questions .....	143
D. Focus Group Transcript .....	145
E. Letter to High School Principal Requesting Participation .....	196
F. High School Participation Agreement .....	198
G. Parental Permission Agreement .....	200
H. Codes Used for Transcript Analysis .....	204
I. Results for Primary Research Question #1 .....	205
J. Results for Primary Research Question #2 .....	211
K. Results for Primary Research Question #3 .....	217
L. Results for Primary Research Question #4 .....	223

M. Results for Primary Research Question #5 .....	229
N. Results for Primary Research Question #6 .....	234
O. Results for Primary Research Question #7 .....	240
P. Results of Test for Gender Interaction .....	246
Q. BalloonSat Notes and Directions .....	253
R. Sample BalloonSat Reports .....	343

## **ABSTRACT**

This study measured the effect of completing a BalloonSat project on student attitude toward science. Seven categories of student attitudes toward science were measured using the Test of Science Relate Attitudes survey (TOSRA). The research anticipated that the BalloonSat project would have similar effects on student attitudes as found in robotics projects, like FIRST. The researcher also investigated whether gender moderated the effects of the BalloonSat project. This study enrolled 138 students from three states and one Canadian province. Students were free to select membership in either the treatment group or the control group. Student attitude toward science was measured prior to the start of the study and at its completion. Mean scores for the control and treatment group were then compared using an analysis of covariance.

The effect of the BalloonSat project only affected one attitude toward science, Leisure Interest in Science. The study did not find gender was a factor in the effects of the BalloonSat project. This study is the first study of the BalloonSat project on grade 7 – 10 students and provides some evidence that a BalloonSat project can impact middle and high school attitude toward science.



## ACKNOWLEDGMENTS

I would like to thank my advisor for helping me get this far. I have never accomplished a project as large as a PhD and study. The efforts of Dr. Jim Ellis was instrumental in the investigation of the BalloonSat project on student attitude toward science in grade 7 – 10 students.

I also need to thank my committee for their feedback and refinement of this dissertation. Dr. Ron Aust, Dr. Doug Huffman, Dr. Phil McKnight, and Dr. William Skorupski, thanks.

The amateur radio community played a large part in locating participating teachers. Amateur radio has a history of helping the community and it was evident again in this study.

Finally, I need to thank Rachel, my wife. Your patience is appreciated and very much in need. I love you.

## LIST OF TABLES

Table	Page
1. G*Power Analysis of Study Design .....	57
2. Details of Participating Schools .....	59
3. BalloonSat Launches .....	62
4. Details of School Participation in Study .....	64
5. Details of BalloonSat Project Membership of Students Participating in Pre-Survey ..	64
6. Details of BalloonSat Project Membership of Students Participating in Post-Survey	65
7. Details of Gender of Students Participating in Pre-Survey .....	66
8. Details of Gender of Students Participating in Post-Survey .....	67
9. Reliability of TOSRA as Measured by Cronbach's Alpha .....	71
10. Klopfer's Six Categories of Attitude toward Science .....	71
11. TOSRA's Seven Categories of Attitudes toward Science .....	72
12. Point Allocation for TOSRA Items .....	73
13. Pre and Post-Survey Descriptive Statistics .....	84
14. Summary of Research Findings Primary and Secondary Questions .....	95
15. Comparison of Means for Primary Research Question #1 .....	99
16. Comparison of Means for Primary Research Question #2 .....	101
17. Comparison of Means for Primary Research Question #3 .....	103
18. Comparison of Means for Primary Research Question #4 .....	104
19. Comparison of Means for Primary Research Question #5 .....	107
20. Comparison of Means for Primary Research Question #6 .....	109
21. Comparison of Means for Primary Research Question #7 .....	110

## LIST OF FIGURES

Figure	Page
1. Schools and Number of BalloonSat and Non-BalloonSat Students Participating in Pre-Survey .....	65
2. Schools and Number of BalloonSat and Non-BalloonSat Students Participating in Post-Survey .....	66
3. Focus Group Questions .....	77
4. Student Gender .....	83
5. Pre and Post Mean Scores by Attitudinal Category .....	85

# CHAPTER I

## INTRODUCTION

### Significance of the Study

“Where once nations measured their strength by the size of their armies and arsenals, in the world of the future knowledge will matter most.”

(President Bill Clinton, May 18, 1997)

The United States is facing an economic challenge in science and engineering, brought about by an aging workforce and increased competition overseas. These factors may lead to weakened economic competitiveness and increased risk to our national security. This dissertation focuses on one proposed solution: increasing student interest in science, technology, engineering, and mathematics (STEM). In attempting to resolve these issues through education, the United States can maintain control of its economic future and security.

Schools use many methods to teach STEM. One of the more popular is robotics. Robotics is a project-based learning activity that is effective at teaching concepts and increasing student attitudes towards science. Recently, educators have begun using BalloonSats because they are in many ways similar to robotics.

The BalloonSat is a student-engineered structure housing science experiments. Students tether their completed BalloonSat to a weather balloon, which then carries it into the mid-stratosphere to collect data and images. After its recovery, students download and analyze the data collected by their BalloonSat using mathematical tools like spreadsheets and image editors. The BalloonSat, as a combination of robotics and science, may become an important addition to the STEM curriculum by proving its effectiveness at improving student attitude toward science.

### **The Global STEM Workforce**

According to the National Science Board, 26 percent of the United States science and engineering workforce is older than age 50 (National Science Board, 2008). Therefore, the United States can expect an increased number of retirements over the next twenty years. The number of students entering the science and engineering field continues to increase and will at some point, equal the number of retirements. At that point, the growth of workers within the science and engineering field will stop growing and the mean age of this important workforce will increase. Older, more experienced employees are known for their increased productivity; however, experience indicates that the development of new ideas is the domain of younger workers. The Defense Advanced Research Projects Agency recognizes an aging American science and engineering workforce competing against a growing and younger foreign workforce as a potential long term risk to the United States. In recognition of this possibility, DARPA issued in 2010 a funding announcement requesting proposals to create programs that encourage

more students to graduate with STEM-related majors in college, especially in the computer sciences (DARPA, 2010).

If an insufficient number of young American workers are available to fill the ranks of our aging science and engineering workforce, then the rate of technological change within the United States may slow, leading to long-term economic decline (National Science Board, 2006). The areas negatively impacted include the creation of new industries, the quality of public health, our nation's ability to care for the environment, and the standard of living (The National Academies, 2007).

Along with issues related to economic well-being, national security also may be negatively impacted. This risk has caught the attention of the current administration. For example, the President's 2010 National Security Strategy stated that the development of technology by a large and well-trained science and engineering workforce advances United States security in many areas, including:

1. Protection from attack, including asymmetrical attack from terrorist organizations
2. Protection from the global spread of disease
3. Protection of the global supply chain for our nation's goods and resources
4. Detection of smuggled weapons
5. Protection of critical infrastructure like communications, transportation, and information

(Obama, B., 2010)

Other countries have recognized the importance of having a strong STEM workforce. As a result, more countries are expanding into international trade and improving their STEM readiness by increasing the educational opportunities of their citizens and developing infrastructure to support STEM growth and development.

Countries are increasing the percentage of money spent on research and development, in

comparison to their gross domestic product (GDP).

These changes are having their intended effect. The National Science Board reports that the United States still has the highest concentration of knowledge and technology intensive (KTI) industries per GDP. Partly because of the historically large lead the United States has enjoyed in this field (National Science Board, 2008; National Science Board, 2012). The growth of KTI industries per GDP in other countries, like China, however, is rapidly increasing. For example, labor productivity in China, which the National Science Board says coincides with the concentration of KTI industries per GDP, grew at a 10 percent rate in the 1990s. India and Russia saw their labor productivity grow from 1.4 percent in the 1990s to 4.9 percent in the 2000s. During this same time frame, the growth of labor productivity in the United States slowed from a growth rate of 1.9 percent to 1.3 percent. The realization of increased KTI growth potential overseas is reflected by investments. In 2012, United States investments in overseas KTI industries is predicted to be \$1.1 trillion, while foreign made investments in United States KTI industries is predicted to only be \$700 billion (National Science Board, 2012).

The increased support for STEM-related industries in China has resulted in China's share of global high-tech manufacturing growing to 19 percent of the global total. Over the same ten years, the United States' share dropped from 42 percent to 33 percent (National Science Board, 2012).

A result of the growth of the technology sector outside the United States is an increasing demand for a STEM-educated workforce overseas (National Science and Technology Council, 2000). This increased demand overseas may make it more difficult

for United States companies to hire qualified workers in the future.

### **Student Attitude toward Science**

There are multiple ways to address the issues of an aging STEM workforce and increasing STEM competition from overseas. One approach begins by designing the science curriculum to increase student attitude toward science. Attitude is defined as a personal disposition toward an object. The object need not be physical, but also may include concepts and activities. Science is one example of an attitudinal object (Koballa, 1988).

Attitude is not a predictor of behavior like mass is a predictor of weight. Instead, Koballa states that attitude is a probabilistic statement. One reason attitude is not a predictor is that while it affects a student's intentions, other mediators, like peers and parents, exert their influence on the student's final behavior. Mediators are capable of redirecting or reinforcing a student's final actions away from objects for which the student has a strong positive attitude. A student's attitude is only an indicator therefore of how likely that student will act in a particular manner (Koballa, 1988).

This dissertation uses Koballa and Crawley's definition of attitude toward science, namely, "a general, enduring positive or negative feeling about science". This is not the same however, as a student's belief about science. Belief about science is what the individual believes is true about science. Two examples include that science is too dangerous for the public good and that science is too mathematical (Koballa & Crawley, 1985).



Attitude toward science is not the same as scientific attitudes. Scientific attitudes encompass the attitudes and behaviors of scientists. These include understanding the value of examining evidence and withholding judgment (Koballa, 1988).

Attitude is an important goal of science education because it is one of several factors students use when deciding among multiple interests (Crawley & Koballa, 1994). Nonsocial factors also affecting student attitude toward science include the following four examples provided by Koballa:

1. Gender
  2. Differences in science programs
  3. The biological versus the physical sciences
  4. Student grade level
- (Koballa, 1988).

Student attitude toward science influences student career choices, learning goals, and the ability to deal with future technological change (Koballa & Crawley, 1985). As a result, increasing student attitude toward science may tilt the playing field toward more STEM-related activities, education, and career choices.

### **Teaching to Address Attitude toward Science**

Student engagement is one factor of student achievement. Students engaged in active learning, take more responsibility for their learning, understand more content, have more favorable learning experiences, and develop positive attitudes. Active learning is an example of a constructivist approach to teaching, which promotes the interaction between students and problem solving (Lo, 2010; Springer, Stanne, & Donovan, 1999).

An example of constructivist teaching is inquiry-based learning. Studies have shown that inquiry-based learning develops positive outcomes in understanding content, in the ability to solve problems, and in attitude toward science (National Research Council, 2000). Inquiry-based learning also engages students in science questions, encourages them to use evidence to develop answers, helps them to consider alternative conclusions, and requires them to communicate their findings. Inquiry-based learning can also be effective at bringing all students to higher levels of achievement (National Research Council, 2011). In addition, a review of the research by David Haury also shows that inquiry-based learning promotes science literacy and positive attitude toward science in students (Haury, 1993; National Research Council, 2000).

One reason inquiry generates these results comes from engaging students in collaborative work groups. Collaborative groups permit each student within the group to contribute to the inquiry using his or her strongest approach (Weissman & Boning, 2003). This is an example of social constructivism. According to the theory of social constructivism, the individual cognitively develops through his or her interaction with the community. Vygotsky explains that this interaction takes place between the learner and a knowledgeable tutor within a social group. The knowledgeable tutor can explain, demonstrate, and guide the learner in acquiring new knowledge (Vygotsky, 1978).

There are several approaches to inquiry-based learning. There are no sharp boundaries between approaches and two teachers may call the same method by different names. However, according to Michael Prince and Richard Felder, all styles of inductive teaching begin with the instructor presenting students with a challenging problem. At this point, students know just enough to begin their investigation, but not enough to complete

it. Students then expand their knowledge as they solve the challenge (Prince & Felder, 2007).

One way the methods of inquiry-based learning vary is by the amount of guidance provided by the teacher. At one extreme is guided inquiry, where the teacher provides a large amount of guidance to students. At the other extreme is discovery learning, where the teacher provides almost no guidance to the students.

In discovery learning, students must discover their own solution. As a result, students experience more trial and error with discovery learning. There are, according to Prince and Felder, three variations of discovery learning which incorporate varying levels of teacher guidance. These are problem-based learning, case-based learning, and project-based learning (Prince & Felder, 2007).

Problem-based learning makes use of open-ended problems modeled after real world examples. The primary focus of the unit is on the learning that takes place during the exercise. To successfully complete a problem-based learning unit, students must investigate what they currently know and what they need to learn in order to address their challenge (Prince & Felder, 2007).

Case-based learning and project-based learning are similar to one another in that students already understand the content needed to complete their assignment. In case-based learning, the teacher presents students with a case describing a given situation, preferably one in which the students have some familiarity and are likely to encounter in their specialty. The goal in case-based learning is for the students to analyze the case and correct their misconceptions (Prince & Felder, 2007).

In project-based learning, students have the goal of developing a product. The students often know what they need to create the final product. As a result, not a lot of new material is learned, and what is learned is not as important as the final product produced by the students (Prince & Felder, 2007). The focus of project-based learning is on developing student knowledge and abilities in technology.

### **Robotics and BalloonSats as STEM-teaching Tools**

Robotics is one example of project-based learning found in both middle and high school. Robotics is popular in schools because it represents a promising method to improve STEM attitudes, skills, and knowledge. Robotics activities help students translate abstract science and mathematical concepts into real world applications. In addition, students are empowered by their ability to design and build artifacts capable of completing a given task (Nugent, Barker, Grandgenett, & Adamchuk, 2010).

In 2007, a study of attitude toward science performed at the University of Kansas found that robotics is capable of increasing high school students' attitude to scientific inquiry (Welch, 2007). Attitude to science inquiry is one of seven attitudes toward science developed by Klopfer and explained more fully later in this dissertation. Increasing this particular attitude toward science implies that robotics helped students adopt a greater acceptance of scientific inquiry as a way of thought (Klopfer, 1971)

BalloonSats are another example of project-based learning. BalloonSats are inexpensive models of satellites, which travel into the mid-stratosphere under large helium-filled weather balloons. As will be described later, many people refer to this

region of the atmosphere as near space. In near space, BalloonSats perform science experiments similar to those performed by satellites in earth orbit.

BalloonSats mimic robotics in many ways. For example, students design BalloonSats to carry out specific tasks using programmable logic, like microcontrollers. (LaCombe, Wang, Nicolescu, Rivera, & Poe, 2007). However, in the case of a BalloonSat, the student's task involves collecting science data in a lethal environment. According to Voss, Dailey, and Snyder, BalloonSats have the following benefits found in robotics:

1. Students have the opportunity to develop and practice problem-solving skills
2. Students are required to design and test software.
3. Students develop technical skills like soldering and circuit testing (Voss, Dailey, & Snyder 2010).

BalloonSats and robotics make use of programmable microcontrollers. Andy Lindsay states that microcontrollers are miniature computers found in many everyday objects. Programmable microcontrollers, like the BASIC Stamp by Parallax, use student-designed software to analyze sensor data in order to react to the world. Because programmable microcontrollers can react to sensor input, they make electronic devices more intelligent (Lindsay, 2005).

BalloonSats more naturally expose students to scientific research and inquiry (Kennon, Roberts, & Fuller, 2008). In a BalloonSat project, students develop and test hypotheses and gather, analyze and interpret data. This makes BalloonSats a tool for introducing students to the scientific method (Voss, Dailey, & Snyder, 2010).

Finally, BalloonSats are capable of generating excitement. As Dr. John Baker of the University of Alabama notes, his students get excited every time they see the pictures from their BalloonSats. One reason students get excited is that pictures from the BalloonSat show the curvature of the earth and the blackness of space (Easton, 2007).

The research on the effectiveness of BalloonSats in science education is insufficient. The most significant study to date investigated the effect of BalloonSats on undergraduate student attitude and learning at Taylor University (Snyder, n.d.). Like the Taylor study, this study will investigate the effect of BalloonSats on student attitude toward science, although in the context of middle and high school. If this study finds that BalloonSats are effective at increasing student attitude toward science, then perhaps BalloonSats also will increase student science engagement. Increased student engagement is an important issue because studies have shown it to correlate with improved student achievement (Van de gaer, Pustjens, Van Damme, & De Munter, 2009). Eighth-grade students with high math scores are more likely to expect to be working in science and engineering fields. These high achieving students are therefore more likely to earn Bachelor degrees in these fields (Tai, Lui, Maltese, & Fan, 2006). Based on the correlation between engagement and achievement, and achievement and earning Bachelor degrees in STEM fields, it is important to engage students while they are adolescents.

## **Personal Interest in the Topic**

I discovered near space in October 1994 at an amateur radio club meeting in Manhattan, Kansas. The radio club's speaker for that month brought a picture of the earth's horizon taken at an altitude of 100,000 feet. The technology used to get that image involved weather balloons, GPS receivers, digital radio, and programmable microcontrollers. Our speaker described it as a poor man's space program and it fulfilled my interest in space exploration and in building high-tech equipment. Since then, I have launched 108 weather balloons, written over 117 magazine articles, and a book on near space.

In 2003, I discovered the BalloonSat project designed by Chris Koehler, the current director of the Colorado Space Grant. The BalloonSat is a small, student-constructed science capsule designed to collect data when attached to a weather balloon and launched into near space. I came to realize that a BalloonSat project is a powerful hands-on, minds-on activity that unites every aspect of STEM into a fascinating science experiment. Better still, the experiment takes place in an environment that students are unable to visit themselves.

## **Problem Statement**

This study measures the effect of a BalloonSat project on grade seven – ten students' attitude toward science. The attitude instrument used in this study is TOSRA, the Test of Science Related Attitudes (Fraser, 1981), which specifically measures attitude in seven scales. The seven scales of attitudes measured are:

1. The attitude toward the social implications of science.
2. The perception of the normality of scientists.
3. The acceptance of scientific inquiry as a way of thought.
4. The adoption of scientific attitudes.
5. The enjoyment of science experiences.
6. The enjoyment of science activities like hobbies.
7. The interest in pursuing a scientific education and career.

Gender is a factor influencing student attitude toward science. Therefore, this dissertation also investigated the influence of this co-factor on how strongly the BalloonSat program affects student attitude toward science.

### **Primary Research Questions**

1. Do grade seven – ten students develop a more positive attitude toward the social implications of science after building a BalloonSat and analyzing its data than students who do not?
2. Do grade seven – ten students develop a more positive attitude toward the normality of scientists after building a BalloonSat and analyzing its data than students who do not?
3. Do grade seven – ten students develop a greater acceptance of scientific inquiry as a way of thought after building a BalloonSat and analyzing its data than students who do not?
4. Do grade seven – ten students develop a greater adoption of scientific attitudes after building a BalloonSat and analyzing its data than students who do not?
5. Do grade seven – ten students develop a greater enjoyment of science experiences after building a BalloonSat and analyzing its data than students who do not?
6. Do grade seven – ten students develop a greater interest in science and science related activities after building a BalloonSat and analyzing its data than students who do not?
7. Do grade seven – ten students develop a greater interest in pursuing a career in science after building a BalloonSat and analyzing its data than students who do not?



## **Secondary Research Question**

Is there a difference in attitude toward science between male and female students after building a BalloonSat and analyzing its data?

### **Definition of Variables**

#### Treatment Group

The treatment group consisted of the students in the classrooms in grades seven - ten whose teachers agreed to participate in this study and who implemented the BalloonSat project.

Independent Variable: Students participating in the BalloonSat project and subdivided into gender of the student.

#### Dependent Variables:

1. Attitude toward the social implications of science
2. Attitude toward the normality of scientists
3. Attitude toward the acceptance of scientific inquiry as a way of thought
4. Attitude toward the adoption of scientific attitudes
5. Attitude toward the enjoyment of science experiences
6. Attitude toward an interest in science and science related activities
7. Attitude toward an interest in pursuing a career in science

#### Control Group

The control group consisted of the students in the same classrooms but who did not participate in the BalloonSat project.

Independent Variable: Students not participating in the BalloonSat project and subdivided into gender of the student.

Dependent Variables:

1. Attitude toward the social implications of science
2. Attitude toward the normality of scientists
3. Attitude toward the acceptance of scientific inquiry as a way of thought
4. Attitude toward the adoption of scientific attitudes
5. Attitude toward the enjoyment of science experiences
6. Attitude toward an interest in science and science related activities
7. Attitude toward an interest in pursuing a career in science

### **Assumptions**

This study assumes the following conditions:

1. Since TOSRA is an anonymous survey, students filled out the survey accurately and validly.
2. Since students in both the treatment and control groups have the same teachers, there is less variability in the data than if the control group was attending a class with a different teacher or in a different school.
3. All sources of variability listed below are normally distributed in both groups:
  - Quality of instruction
  - Courses taken in school
  - BalloonSat experience
4. Since students understand that the comments they make during the focus group were anonymous, they discussed their feeling about the project truthfully.
5. The students participating in the focus group were not strongly biased about the project and therefore, present a valid picture of the experience.

## **Summary**

This introduction explains that this study investigated the effect of a BalloonSat project on student attitude toward science. BalloonSats are similar to robotics and they are one method to teach STEM. Because there has been little research about BalloonSats, this study has the potential to be a valuable addition to the STEM education body of knowledge. This introduction also described the hypotheses, variables, and assumptions of this study.

## CHAPTER II

### REVIEW OF LITERATURE

High quality science, technology, engineering, and mathematics (STEM) education has become a necessity for all American students. The reasons include growing competition from overseas (National Science Board, 2012) and rapid technological changes in American society. There are several methods that primary and secondary teachers use to teach STEM, one being robotics. As it applies to attitude toward science, research indicates that robotic projects have a positive impact. Specifically, in the areas of science attitude as defined by Klopfer (Klopfer, 1971) and measured by the Test of Science Related Attitudes, or TOSRA (Fraser, 1981). As an example, a study by Welch (2007) found that four attitudes toward science increased for students participating in a FIRST (For the Inspiration and Recognition of Science and Technology) robotics challenge. The four attitudes that increased were:

1. The social implications of science
2. The positive perception of scientists
3. The positive attitude toward scientific inquiry
4. The adoption of scientific attitudes

As explained in this chapter, research finds that robotics have many benefits in science, technology, engineering, and technology (STEM) education. Recently, however, BalloonSats have made an appearance in the classroom. BalloonSats are similar to robotics in their use of technology, programming, and engineering. BalloonSats are functioning models of satellites that weather balloons loft into the middle of the stratosphere to collect science data. This makes BalloonSats flying high-altitude dataloggers. BalloonSats have a strong math and science

component due to their being a science experiment. Because BalloonSats can reach altitudes in excess of 100,000 feet and return images that appear similar to pictures taken from space, they may be effective at influencing student attitudes toward science. By increasing student attitudes towards science, BalloonSats may be useful in keeping students motivated for long enough to master STEM related subjects. That mastery may in time lead to the development of an interest in a STEM career. Currently, the literature on BalloonSats in junior and high school education describes launching procedures, recommendations, experiences, and student comments. The author therefore, believes it is time to investigate the effectiveness of BalloonSats at increasing middle and high school student attitudes toward science.

### **Changes in STEM-related Industry and the Workforce**

According to the National Science Board, during the last 25 years, the largest growth in global economic activity has been due to knowledge-intensive services and industries. Globally, these services and industries grew at a 3.5 percent annual rate since the mid 1990's. This is significantly greater than the 2.5 percent annual rate for all other services worldwide (National Science Board, 2008). In 2008, 70 percent of global economic activity involved the use of knowledge-intensive industries and services, like the production of telecommunication equipment and the commercial exploitation of intellectual property (National Science Board, 2008). Seventy percent of the world's economic activity represented \$12 trillion in annual sales.

The growth of knowledge-intensive industries and services has an impact on the nature of the workforce. Today, the United States employs 35 percent of its workforce in service and finance and 23 percent of its workforce in trade. One hundred years ago, the United States employed only 8 percent and 9 percent of its workforce respectively in these areas (Joint Economic Committee, 1999). Although the STEM component of today's workforce is small, only

5 percent of the workforce consists of scientists, engineers, and mathematicians, their impact on the American economy is much greater than their numbers (National Science Board, 2008).

The American Institute of Aeronautics and Astronautics (AIAA), a professional society dedicated to the progress of aerospace science and engineering, reports that enrollment and graduation rates for college engineering majors in the United States was 15 percent of college students. In China, 50 percent of college students are enrolled and graduating with engineering degrees. The growth in engineering degrees granted in China is growing while the number in the United States remains flat (Weigel, 2011).

The growing importance of STEM-related industries to the global economy is taking place at a time when the American workforce is aging. According to the Census Bureau, the ratio of those in the workforce that are younger than 65 to those that are older than 65 was 4.8 to one in 1995. The Census Bureau predicts that this ratio will decrease to 2.8 to one by 2050 (National Science and Technology Council, 2000). This older workforce will require an influx of younger workers to make up for the increasing number of retirees.

### **Industrial and Governmental Responses**

As a result of increasing global competition and the changing workforce, both American industry and government are expressing concerns about the preparation of students for the probable expansion of STEM's importance during the 21<sup>st</sup> century (National Science Board, 2008; Robelen, 2011). An inadequately prepared population will see negative impacts to our nation's income and trade balance. Other impacts include a reduction in the protection of this nation's security, a lowering of the nation's standard of living, and the reduced ability to prevent or react to the problems predicted to occur in the near future, including those caused by climate change (Hira, 2010).

One result over the concern for the possible need for greater public STEM knowledge comes from companies like Micron Technology. As a solid-state memory manufacturer, Micron Technology requires a large and well-trained STEM workforce. On July 21, 2010, Micron announced a one million dollar gift to the University of Idaho to further research on the topic of schools, teachers, and STEM achievement (Micron Technology, 2010).

Industry also is responding to their immediate need for a well-trained STEM workforce. More companies are hiring increased numbers of foreign-trained workers through the H-1B visa program. The federal government grants H-1B visas to industry when they show that they cannot fill their need for expert technicians within the United States. H-1B visas grant qualified foreign workers the privilege to hold technical jobs within the United States for up to six years. The need for foreign talent has grown so great that between 1995 and 2008, that foreign workers with H-1B visas were responsible for more than half of the increase in STEM employment in the United States (Neufeld, 2011; Kerr & Lincoln, 2010).

The American Competitiveness in the Twenty-first Century Act of 2000 was partially responsible for making the growth in foreign workers possible. The act increased the number of non-immigrant H-1B visas granted for well-educated foreign employees until the United States addresses the lack of STEM education in its citizens (American Competitiveness in the Twenty-first Century Act of 2000).

However, the Defense Advanced Research Projects Agency (DARPA), a defense research organization, believes that the increased reliance on foreign workers creates a national security risk. Examples of the risk are apparent in industries that are designing software and hardware for secure financial transactions over networks and reconnaissance satellites, while hiring more foreign employees with H-1B visas (Drummond, 2010).

The federal government responded to the perception of the United States' inadequate STEM readiness with the America Competes Act of 2007. This bipartisan legislation responds to the perceived inability of the United States to compete over the long term with the growing economic powers of China and India (Hira, 2010). According to the America Competes Act, the United States will "invest in innovation through research and development, and to improve the competitiveness of the United States" (America Competes Act of 2007).

One last example of federal response is worth noting. President Obama publicly supports STEM knowledge as a link to international economic competitiveness. Obama issued an order to his council of advisors on science and technology to develop a plan for K-12 STEM education. As part of its plan, the President's council recommended training 100,000 new K-12 STEM teachers over the next decade, creating 1,000 new STEM schools, and developing a STEM education research agency (President's Council of Advisors on Science and Technology, 2010). The President further mentions the need for increased STEM education in his 2011 State of the Union address. He stated that the United States must out-innovate and out-educate the rest of the world in order to remain competitive (Robelen, 2011).

Not everyone agrees the United States is experiencing a crisis in STEM education and preparedness. For example, in the Chronicle of Higher Education, P. Basken stated that the problem lies with industry. Industry, he claims, is not making employment attractive enough for graduating students. As a result of finding STEM-related employment unattractive, students seek occupations requiring less rigorous preparation while offering better financial rewards (Basken, 2009). Gerald Bracey of the High/Scope Foundation is also critical of a STEM crisis. Bracey points out that while American student scores in the Program for International Student Assessment (PISA) are below the average for the world, the World Economic Forum still rates the United States as the world's most economically competitive country (Bracey, 2008). These voices of disagreement represent a minority.



## **Teaching STEM**

American classrooms historically have used many ways to teach STEM, including inquiry-based learning and project-based learning. These two methods belong within the philosophy of constructivism and attempt to engage student interest and increase student attitude. However, issues of accountability like those found in the No Child Left Behind act have, in some cases, encouraged schools to focus their energies on teaching students to pass assessments through lecturing, drilling, and testing. A result is that in some cases, schools reduce the use of constructivist philosophy in science education. (Crescitelli, 2010).

### **Constructivism**

There are many philosophical definitions of constructivism, and some do not apply to the education of students, or pedagogy. These other definitions, like those found in post-modernism do not concern this study. The pedagogical definition of constructivism used in this study refers to students building their knowledge through their educational experiences (Corley, 1997).

Constructivism is essentially a hands-on, minds-on approach to teaching. Unlike didactic teaching methods, teachers are guides and facilitators in the constructivist classroom. They are not experts who just “dump knowledge” into the brains of students. In the constructivist classroom, the creation of new ideas and not just the acquisition of facts is the primary goal (Corley, 1997).

A constructivist recognizes the value of behavioral approaches to teaching. For example, the creation of the foundations of many subjects may benefit most from a behaviorist approach. However, this knowledge typically operates at the lower end of Bloom’s Taxonomy whereas constructivism develops knowledge for the higher end (Cooper, 2007). Therefore, behaviorist teaching primarily focuses on student knowledge, comprehension, and application, whereas constructivist teaching focuses primarily on analysis, synthesis, and evaluation (Bloom, 1971).

The pedagogical learning theory of constructivism has at its core, three principles. First, it recognizes that in order for a student to learn, he or she must make use of prior knowledge. Second, in order for a student to learn, he or she must actively be involved in the process; there is very little room for passive learning in constructivism. Finally, since students have prior knowledge and are active learners, each student's knowledge is continuously evolving and expanding (Cooper, 2007).

Constructivism can be broken into two broad theoretical categories, cognitive and social. Cognitive constructivism focuses on how the individual constructs knowledge based on their experiences or natural development (Lui & Matthews, 2005). In this category, the learner acquires knowledge by acting on their world. Social constructivism on the other hand, focuses primarily on the learner's social environment. In social constructivism, the learner adopts his or her culture's knowledge and meaning. Much of that adoption of knowledge comes about through interaction with peers and family (Lui & Matthews, 2005).

It is worth reviewing the contributions of four individuals in the development of constructivism as pedagogy. They are Jean Piaget, Lev Vygotsky, Jerome Bruner (Chrenka, 2001), and David Ausubel (Lui & Matthews, 2005). Piaget's theory of personal constructivism was a reaction to the behaviorist theories of his day (Matthews, 1993). Piaget stressed the importance of the individual in his or her learning through assimilation and accommodation, as opposed to the individual's respond to stimuli created by a teacher. In Piaget's definition of constructivism, learning takes place naturally (genetically), as a process of maturation and development. Piaget developed the following four stages of development.

### Sensory Motor

In this stage, young children up to the age of two explore the world through their senses and movement.

### Preoperational

At this transitional stage, children ages two to seven can act on physical objects, but have difficulty mentally manipulating their properties. Children at this stage cannot understand the view point of another individual. Egocentric is the term used for this lack of ability to envision another person's perspective.

### Concrete Operational

At this stage, children ages seven to eleven can begin to understand that other people have a different perspective than theirs. Children of this age also have the ability to think of objects in a mental sense and perform simple operations on them, like sorting them.

### Formal Operation

Children at this stage are fully capable of thinking abstractly and logically. This gives them the ability to perform mental experiments without interacting with physical objects (Gardner, 1973).

Vygotsky gives us a different perspective on constructivism. In Piaget's case, constructivism referred to the individual's development through maturation and experimentation with the outside world (Gardner, 1973). In Vygotsky's case, constructivism refers to the development of the individual through social interaction (Cooper, 2007; Lui & Matthews, 2005). Vygotsky's theories require that interaction occur before development can take place. Those interactions occur with the assistance of an external source (Vygotsky, 1978). In Vygotsky's constructivism, a person more knowledgeable must interact with the child before that child will learn. That other person doesn't necessarily have to be an adult; he or she can be a more knowledgeable peer (Lui & Matthews, 2005). Finally, in Vygotsky's constructivism, learning takes place in manageable steps. The steps must fit within the child's Zone of Proximal

Development (ZPD). Vygotsky defined ZPD as the gap between what a learner is unable to accomplish without help, but able to accomplish with the help of a more knowledgeable person. According to Vygotsky, activities within the ZPD promote learning while activities outside the ZPD do not (Vygotsky, 1978)

Jerome Bruner's approach to constructivism is called Discovery Learning. In Discovery Learning, students learn through problem-solving. They discover new facts and relationships by interacting with physical objects, experimentation, or by exploring issues and controversies. The interaction with objects motivates students to be engaged actively in learning (Learning Theories Knowledgebase, 2011).

American psychologist, David Ausubel expanded the work of Piaget as he investigated the relationship between what students currently know and the process of their learning. Ausubel argued that instruction is more effective when its activities take into account what student currently knows. Without an appropriate background, students are unable to develop meaning from their learning materials. To this end, Ausubel recommended using advanced organizers as a scaffold. The scaffold, when properly designed, helps students to process the learning materials, which may include lectures (Ausubel, 1960).

One of the complaints against constructivism is that it can become an excuse for teachers not to teach. Constructivism is not an excuse, as the teacher is an important part of the student's creation of new knowledge (Chrenka, 2001; Corley, 1997). As the subject matter expert, the teacher is responsible for developing the activities and scaffolding that helps his or her students actively develop knowledge. The teacher also is critical for ensuring that misconceptions do not develop within the students' thinking (Chrenka, 2001).

## **Inquiry**

The Soviet launch of Sputnik 1 on October 4, 1957 challenged the view of the United States as a global leader. Soon after the launch of the larger and heavier Sputnik 2, the federal government increased its focus on the American science education system. One result is that the federal government promoted the increased use of inquiry in science education (Pine & Aschbacher, 2006).

Inquiry is a constructivist approach to teaching in which the student takes an active role in making the learning process more effective. Because students are actively engaged in their learning, inquiry is a good teaching method when student understanding is more important than reciting facts (National Research Council, 1996). During inquiry, students collaborate with peers to construct knowledge and they learn to remain focused on the task. Working with peers and remaining on task helps students develop stronger connections between new content and their prior cognitive structures, or understanding of the world. As a result of the benefits of teaching with inquiry, students come to understand the application of science in their lives and how science knowledge is important for both future citizenship and careers (Geier, Blumenfeld, Marx, Krajcik, Fishman, Soloway, & Clay-Chambers, 2008).

Inquiry may lead to greater scientific understanding because during inquiry, students are engaging in the process of science (National Research Council, 2011). According to Inquiry and the National Science Education Standards, inquiry in the classroom includes the following features, which scientists also use in their work:

1. Learners engage in scientifically oriented questions
2. Learners follow their evidence rather than non-scientific explanations
3. Learners develop explanations based on the evidence they collect
4. Learners take into consideration alternative scientific explanations
5. Learners share results and justify conclusions

(National Research Council, 2000)

According to Banchi and Bell (2008), there is no single form of inquiry. Banchi and Bell classify the forms of inquiry based on their similarity to scientific investigations. This standard permits them to divide the range of inquiry into the following four categories, confirmatory, structured, guided, and open.

In confirmatory inquiry, the teacher presents students with the question they are to investigate and the procedures they will use in the investigation. The typical function of confirmatory inquiry is to reinforce content that students already have learned.

Closely related to confirmatory inquiry is structured inquiry. In structured inquiry, the teacher still gives students the question to investigate and the procedure to follow. The students however, now are required to generate an explanation from their results rather than fill in measurements or check off boxes.

Next in this progression of inquiry is guided inquiry where the teacher only gives the question that the students are to investigate. The students must develop and carry out the procedure.

Finally, there is open inquiry. This form of inquiry is most similar to the work of scientists. During an open inquiry, students generate the question they want to investigate and the procedure. This is the type of inquiry used in science fairs.

Minner, Levy, and Century argue that guided inquiry is better in the classroom than open inquiry. In guided inquiry, students learn to develop questioning skills and investigative methods. In addition, they argue that with inquiry learning, students spend more time compared to classrooms not using inquiry. By spending more time on task, students are able to acquire more of the content required by state standards (Minner, Levy, & Century, 2010). Marshall and Horton also stress the need for teacher guidance during inquiry. With teacher guidance, students can develop higher level thinking skills more effectively (Marshall & Horton, 2011).

There are theoretical and experimental reasons to believe that inquiry has a positive influence on student outcomes, especially in promoting scientific understanding (National Research Council, 2000; National Research Council, 2011). For example, the National Academies is developing new science and engineering education standards for grades K-12. The new standards will promote students using of science and engineering practices (in place of inquiry). The National Academies believes that incorporating science and engineering practices in the classroom will prepare students to tackle some of the issues concerning the world today, including increased the access to clean energy, the prevention and treatment of disease, feeding growing populations, increasing the amount of clean water, and environmental change (National Research Council, 2012).

According to Corcoran and Silander (2009), during inquiry, students develop science-related questioning skills, develop their own experiments, collect data, make conclusions based on their data, and communicate their results to others. Minner, Levy and Century (2010).list similar benefits when they state that inquiry leads students to the activities of investigating, actively thinking, and drawing conclusions.

Another reason that inquiry should be effective is that during inquiry, students spend less time in lower cognitive levels and more time in higher cognitive levels. This makes inquiry an important part of the curriculum when reasoning and critical thinking are included within the goals of instruction (Marshall & Horton, 2011). This deeper engagement with the content helps students retain knowledge for a longer period of time. In addition, students are able to apply the learned content more flexibly (Lo, 2010).

When inquiry connects ideas from different disciplines, students report that it helps them learn the material better. This is the result of students seeing practical applications for the material they are learning (Weissman & Boning, 2003).

Furthermore, when students work together in cooperative groups, as they do in inquiry, the social aspect of inquiry learning helps strengthen what the students learn (Sanders, 2009).

Setting aside theoretical or philosophical justifications, a body of research investigating the effectiveness of inquiry in science education exists. Their results are not always conclusive and other factors can have a greater influence on the effectiveness of teaching methods than inquiry. However, what follows are four examples of studies on inquiry's effectiveness.

In a study on the effectiveness of inquiry to teach the scientific understanding of tides, researchers Ucar and Trundle (2011) performed a quasi-experiment involving 96 preservice teachers. Ucar and Trundle divided the teachers into three groups. One group learned about tides through traditional classroom lecture and discussion. The second received traditional education mixed with technology (a tide simulator application). The last group learned about tides through inquiry supported with online tide data. Prior to the study, an assessment found that none of the preservice teachers had a scientific understanding of tides.

At the completion of the study, study participants were assessed on their scientific understanding of tides through interviews and drawings made by the preservice teachers. Forty-three percent of the preservice teachers receiving traditional education displayed a scientific understanding of tides. Forty-six percent of the mixed group displayed a scientific understanding of tides. Seventy-two percent of the inquiry group displayed such understanding (Ucar & Trundle, 2011). This study of preservice teachers indicates a level of effectiveness for inquiry, at least for postsecondary students planning to become teachers.

In the second study, Minner, Levy, & Century (2010) conducted a review of 138 studies performed between the years 1984 and 2002. They found that 51 percent show what the authors say is a "clear, positive trend" for the effects of inquiry on student learning. In a further review of the studies, the authors found nine that were suitable for evaluating the effectiveness of inquiry to



teach content. Of those nine, six concluded that there was a statistically significant improvement in student learning through inquiry. The three remaining studies explained that other factors, like how teachers performed during the study, are possible reasons that inquiry was not beneficial (Minner, Levy, & Century, 2010). Even when inquiry was effective at teaching content, the amount of inquiry is not found to correlate with student learning. In other words, increased time spent using inquiry does not correlate with increased student learning (Minner, Levy, & Century, 2010).

In a large scale study of inquiry, Geier et al (2008) tested a large urban population of 5,000 seventh and eighth grade students over three years. Scores on the Michigan Educational Assessment Program (MEAP), a state standards assessment, was the measure of student success. Two groups of students received at least one inquiry-based unit. The two groups were different in the number of students. The authors explain that they expect that the larger group would experience less personalization during their inquiry units. The third group, the control, learned science using traditional methods.

On MEAP, the small inquiry group had a mean MEAP score of 389.16 while the control students had a mean MEAP score of 340.40. This resulted in a 19 percent increase in the number of inquiry students passing MEAP. In the second evaluation of scores, the large inquiry group had a mean MEAP score of 360.05 while the control students had a mean MEAP score of 320.03. This resulted in a 14 percent increase in the number of inquiry students passing MEAP. The study found that student retention of content after 18 months was greater on average for the inquiry students (Geier et al, 2008). Finally, due to the increased number of males passing MEAP, the authors conclude that inquiry is effective at closing the gap between male and female student achievement (Geier et al, 2008).

In a quasi-experiment involving approximately 1,000 students in three states, Pine and Aschbacher (2006) measured the effectiveness of inquiry on students' ability to perform inquiry. Student SES and teaching method (text books or inquiry) were factors used to group students. In a test of content knowledge given at the beginning of the study, a strong correlation between student SES and content knowledge was uncovered. The authors then develop four performance assessments to measure how effectively students could design studies.

Results from the study indicated that student SES was the largest factor in determining the success of a student's ability to complete an inquiry. Whether students were taught using inquiry or textbooks was found not to be a significant factor. In the single inquiry test, students taught using inquiry performed only eight percent better than the text students did. (Pine & Aschbacher, 2006).

Critics of inquiry base their comments on both the perceptions of its implementation and the research findings. To start, how the term inquiry is used is not standardized (Minner, Levy, & Century, 2010). This makes it difficult to evaluate inquiry in the first place. Under perceptions, there is some claim that inquiry represents an absence of instruction. Another perception is that the use of inquiry can lead students to construct their own knowledge that isn't scientifically acceptable (Corcoran & Silander, 2009). These criticisms appear directed towards open inquiry rather than guided inquiry. However, there is no reason that open inquiry must be the only form of inquiry used in the classroom. As Marshall and Horton (2011) state about exploration in inquiry, to be effective, exploration during inquiry must occur within boundaries set by the teacher. In other words, teachers are important to keeping students working efficiently on their tasks during an inquiry.

In addition, the results of studies are mixed and not all researchers agree that the ability to perform inquiry should be a goal of science education. In a review of 138 inquiry studies, it was

found that how well teachers carry out procedures can cloud results (Minner, Levy, & Century, 2010). With the diverse ways students across the country are taught science, making fair comparisons of inquiry and book learning is difficult (Pine & Aschbacher, 2006).

### **Project-based Learning**

The interest in improving K-12 math and science increased significantly after the publication of the 2003 TIMMS results. One proposal was to add inquiry in the form of project-based learning or PBL to the science curriculum (Rogers, Cross, Gresalfi, Trauth-Nare, & Buck, 2011).

Project-based learning is an instructional approach that places equal emphasis on the development of both content knowledge and critical thinking skills (Rivet & Krajcik, 2008; Rogers, Cross, Gresalfi, Trauth-Nare, & Buck, 2011). Project-based Learning is a form of inquiry in which students create and manage a learning project (Corcoran & Silander, 2009). In project-based learning, student-relevant, real world problems or realistic simulations are the conduit to constructivist learning. The project is long-term and generally incorporates multiple subjects. (Rogers, Cross, Gresalfi, Trauth-Nare, & Buck, 2011). Project-based learning is most effective when student teams are required to carry out large portions of the task. A teacher is necessary to give students occasional input to keep them focused on completing the project (Corcoran & Silander, 2009).

There are several reasons why project-based learning should be an effective teaching method. First, during project-based learning, students learn multiple topics from multiple perspectives. Each new perspective strengthens the student's learning experience (Rogers, Cross, Gresalfi, Trauth-Nare, & Buck, 2011). Second, planning and designing are long term processes. As a result, students remain engaged for long periods of time as they develop and refine the

artifact of the project. Another explanation for the success of project-based learning is that students work in groups (Mishra & Girod, 2006). According to Vygotsky's social constructivism, students learning within their zone of proximal development need the help of adults or student peers to order to understand material. This permits advanced students within the team play the part of peer (Vygotsky, 1978). Finally, the project's artifact can act as a mindtool in accordance to Papert's philosophy of constructionism (Mishra & Girod, 2006).

Philosophical support for the effectiveness of project-based learning is found in Edgar Dale's Cone of Learning. The cone suggests that after two weeks, student recollection varies based on the learning method used as shown below:

- Students remember ten percent of what they read (a form of passive learning)
- Students remember 20 percent of what they heard (a form of passive learning)
- Students remember 30 percent of what they see (a form of passive learning)
- Students remember 50 percent of what hear and see (a form of passive learning)
- Students remember 70 percent of what they say (a form of active learning)
- Students remember 90 percent of what they say and do (a form of active learning)

(Verma, Dickerson, & McKinney, 2011)

Because there is no universally agreed definition of project-based learning, it is difficult for every study to identify benefits specifically due to project-based learning (Thomas, 2000). However, one program using project-based learning, MarineTech, finds success teaching middle and high school students about ship engineering (Verma, Dickerson, & McKinney, 2011).

Other studies, like that made by the Expeditionary Learning/Outward Bound (ELOB) and Co-nect school that only find modest but still statistically significant gains in academic outcomes from project-based learning (Corcoran & Silander, 2009).

Another study of 73 students evaluated the effectiveness of using an online STEM teaching tool using project-based learning to design an audio speaker. At the conclusion, the study found that students gained both conceptual and procedural knowledge and developed a

greater interest in creating the project's artifact. In addition to finding correlations between attitude, cognition (understanding), and behavior, the study also found that students were more likely to use teamwork, encouragement, and persistent in their work. The study also found that after completing the online project-based learning exercise, students more actively explored the speaker design (Lou, Liu, Shih, & Tseng, 2011).

### **Engagement**

Before research can begin on the effects of engagement on academic achievement, we must clarify the concept itself. A multidimensional definition of engagement consisting of academic and social engagement is one typical interpretation. Dunleavy and Milton (2008) argue that the following three dimensional model of engagement is a useful model that promotes academic equality and helps teachers increase academic achievement in students.

The first dimension is social engagement. This is a measure of what extent a students is engaged in school life. Examples include being a part of school clubs, sports teams, and student government. Students with a large social engagement tend to have friends and tend to like being in school.

The second dimension is academic engagement. Academically engaged students complete their homework, attend each class, and have the academic support of family and friends. Students who are academically engaged complete classes, gain credits, graduate, and make plans for post-secondary education (Dunleavy & Milton, 2008).

The final dimension of engagement is intellectual engagement. It is not common to discuss this dimension and therefore, it represents a new focus on engagement. Dunleavy and Milton describe intellectual engagement as the student being cognitively involved with learning

the task at hand. This definition aligns well with a constructivist approach to education.

Intellectual engagement according to Dunleavy and Milton develops through the exploration of ideas, working on authentic problems, and problem solving. To help students develop intellectual engagement, teachers and parents must be involved with the student to lend support and encouragement. The result of increased intellectual engagement is that students persist in learning when it gets difficult or complex (Dunleavy & Milton, 2008).

Student engagement can be an important factor in student achievement. In an analysis of school engagement of 2,270 students in the Flanders (a Dutch-speaking region of Belgium) found that student engagement in school decreased from grades seven to twelve. However, the less decline in student engagement, the higher the student's language development (Van de gaer, Pustjens, Van Damme, & De Munter, 2009).

Developing student engagement also can be an important learning goal. A student's ability to engage in learning tasks trains his or her mind for the skills and knowledge needed for academic success and future careers. A deep mental engagement also increases the equality of the educational experience for all students. This increased equity results from the reduced drop-out and increased graduation rates of academically engaged students (Dunleavy & Milton, 2008). Therefore, engagement should be considered both a strategy to raise academic achievement and as an outcome of education (Van de gaer, Pustjens, Van Damme, & De Munter, 2009; Dunleavy & Milton, 2008).

### **Attitude**

Cannon and Simpson remind us that affective outcomes can be one goal of science education (Cannon & Simpson, 1985). In fact, around much of the world, increasing student attitude toward science is an important aim of science education (Fraser, 1981). One reason attitude is important is that research tends to show that student attitude toward a subject

influences how long that student will study for that subject. Furthermore, Krynowsky (1988) points out six studies suggesting a modest correlation between student attitude toward science and achievement in science. While Krynowsky reports that the correlation is small in amount, the relation between attitude and achievement still is statistically significant (Siegel & Ranney, 2003). Complicating the relationship between attitude and achievement however, are studies suggesting that student achievement also affects student attitude (Marsh, Hau, & Kong, 2002).

In order to study the effect of attitude, it is important to first define attitude. In a study of attitude performed by Williams, Kurtek, and Sampson (2011), they used the following attitude construct. The first construct is self-efficacy, or what a student believes about his or her ability to strengthen their knowledge of science. The second construct is interest and it involves a student's curiosity regarding science. The third construct is value. This is a measure of how much a student, his or her family, and culture feels science is an important subject to know. The final construct is identity. Identity is a measure of how likely a student can see him or herself working as scientists.

Oliver and Simpson (1988) on the other hand use the following construct of student attitude toward science for their study. First is attitude toward science. This construct is a measure of how much a student likes science. Oliver and Simpson explain that students can do well in science without liking it; however, liking science may give students an extra push when they find the subject material difficult. The second construct is science self-concept. This construct is a measure of how likely students believe they can be successful in the science classroom. The last construct of attitude is achievement motivation. This construct is a measure of how often a student tries to do well in class. This last construct of attitude is especially important when learning new content is difficult.

Oliver and Simpson found that when the constructs that they developed to measure attitude, namely attitude (or interest) toward science, science self-concept, and achievement motivation, are measured, there is a positive correlation between them and student achievement in science. Oliver and Simpson use student grades as a measure of student achievement, a measurement that some may argue is not a true measure of success. While sympathetic to this view point, Oliver and Simpson explain that grades in class are the most frequently used indicator of success (Oliver & Simpson, 1988).

In their longitudinal study high school students, Oliver and Simpson found that attitude toward science accounts for 20 percent of the variance in chemistry achievement in 11<sup>th</sup> grade and 30 percent in 12<sup>th</sup> grade. They also state that other studies typically do not report a relationship between attitude and achievement that is any greater than ten percent (Oliver & Simpson, 1988).

However, in Human Characteristics and School Learning, Cannon and Simpson (1985) report that that 25 percent of a student's achievement in science correlates with attitudes, school environment, and self concept. Certainly not all achievement in the science classroom traces back to student attitude. Other factors include motive for success, student expectations, the learning environment, and factors from home, culture, and peers.

A study investigating the use of technology (graphing calculators in this case) in mathematics finds that letting students use technology to perform repetitive tasks increases their attitude toward mathematics (specifically probability ) (Tan, Harji, & Lau, 2011). Because of the frequent use of mathematics in science, perhaps a case can be made that permitting students to use technological tools to simplify data processing will increase their attitude toward science. Otherwise, self-efficacy in science, or a student's belief in their ability to do well, is the most important attitude construct that the science classroom should focus on developing. When



students feel they can complete an assignment successfully, they try harder and are more persistent (Oliver & Simpson, 1988; Williams, Kurtek, & Sampson, 2011).

However, even where the relationship between attitude and achievement are not clear, several factors do influence a student's attitude toward science. According to Germann (1988), factors include the following:

1. Student's perception of his or her science teacher
2. Anxiety towards science
3. Value of science
4. Self-esteem at science
5. Enjoyment of science
6. Attitude of parents, peers and friends toward science
7. Nature of the classroom environment
8. Past achievement in science
9. Fear of failure in the classroom

### **Measures of Science Attitude**

In the research on the effects of curricular treatments, there are many effects that a researcher can measure. One of them is how the treatment affects student attitude. This study proposes to evaluate how BalloonSats affect student attitude toward science. Therefore, a search for an attitude instrument capable of measuring attitude with reliability and validity was undertaken. In the search for an instrument, the author found that scientific attitude has many definitions. Hugh Munby (1997) at Queen's University in Ontario, believes that the concept of scientific attitude becomes clearer when divided into two arenas: attitude toward science and scientific attitude. Attitude toward science incorporates concepts like a student's perception of scientists, interest in pursuing science careers, interests in the science aspect of hobbies, and interest in taking science classes (Germann, 1988). This is the student attitude that this study will attempt to measure.

Scientific attitude on the other hand, refers to a student's preference for resolving questions about the natural world with a scientific manner. Scientific attitudes are those traits that are important to the work of scientists. They include having an open-mind, being objective, rational, and skeptical, having a curiosity about natural phenomena, and engaging in critical thinking (Krynowsky, 1988; Germann, 1988). This version of attitude is appropriate for future research on BalloonSats if they are found to be effective at increasing student attitude toward science.

## **Two Attitude Instruments**

### **The Scientific Attitude Inventory**

The usefulness of an attitude instrument begins by analyzing the construct used to design it. This means that while measurements of an instrument's reliability and validity are useful, they are not sufficient. Because attitude is a multifaceted picture of a person, attitude instruments should not create a single attitude score (Osborne, 2003). The researcher found two attitude instruments that generated scores for several aspects of attitude while also having a history of analysis of their construct. These two science attitude surveys researched were the Scientific Attitude Inventory (SAI) by Moore & Foy (1997) and the Test of Science Related Attitudes (TOSRA) by Fraser (1981).

The Scientific Attitude Inventory (SAI) defines scientific attitude as an opinion held by the subject. It divides attitudes into the two categories of emotional and intellectual. During the initial design of SAI, a panel of experts evaluated the validity of the initial 112 statements written for SAI. Their evaluation reduced the initial 112 statements down to 60. Students responded to statements using a six-point Likert scale. The even number of Likert scale items meant students were required to express an option, as there was no neutral response. Its designer's determined

the reliability of SAI using a test-retest comparison using low-ability tenth-grade biology students. After measuring three groups of students and accounting for teacher variability, the reliability of SAI was determined to be 0.934 (Moore & Sutman, 1970).

In 1997, Moore and Foy revised the Scientific Attitude Inventory to eliminate gender inequality and to improve the readability of the assessment. The new version is known as SAI II, or SAI revised. There were only 40 items in the SAI II and students respond using a 5-point Likert scale. Moore and Foy assumed the validity of the new version was unchanged from the older version. A test of the reliability of the SAI II using 557 sixth, ninth, and 12<sup>th</sup> grade students found SAI II to have a Cronbach's Alpha of 0.781 (Moore & Foy, 1997).

In his study of SAI II, Hugh Munby (1997) agreed that internal reliability of the SAI II remains proven, but he called into question its validity for the following two reasons:

1. The field trial of SAI II presents very little evidence for what this attitude assessment measures.
2. The field of SAI II does not show that the components of attitude that SAI II measures are distinct from one another.

Munby argued that SAI II required construct validity and not validity as determined by a panel of judges. One reason is that a panel of judges may not read questions in the same way that students read them. Therefore, relying on panel of judges is insufficient to prove validity. Munby instead recommends using convergent and discriminate measures of validity. This is a process where the new assessment is tested against several established assessments. If the assessment is valid, then it will generate similar scores for similar assessments and dissimilar scores for dissimilar assessments. Since the convergent and discriminate evaluation may not be a realistic approach to determining validity, Munby also recommends using cluster or factor analysis. Munby then states that a cluster analysis of SAI by Nagy in 1978 and the factor analysis of SAI II performed by Moore and Foy do not confirm the validity of SAI II (Munby, 1997).

In their confirmatory factor analysis of SAI II, Lichtenstein et al also failed to find support for the 12 factor design of SAI II. One possible reason stated is that there are only 40 questions for the 12 factors measured (for a mean of 3.3 questions for each factor). However, in an exploratory factor analysis, three of 12 factors were found to be significant. However, ten questions (out of 40) in SAI II did not measure these three factors. Therefore, the author claims the validity of these three scales was not confirmed (Lichtenstein et al, 2008).

### **The Test of Science Related Attitudes**

Leopold Klopfer (1971) created a definition of attitude toward science based on six affective behaviors. Researchers have found Klopfer's six affective behaviors useful in their investigations of attitude in the science classroom (Osborne, 2003). The six themes of attitude toward science described by Klopfer are:

1. Social implications of science
2. Attitude toward scientists and scientific inquiry
3. Adoption of scientific attitude
4. Enjoyment of science lessons
5. Leisure interest in science
6. Career interest in science

Barry Fraser at the Macquarie University, Australia created a survey in 1977 to measure attitude toward science based on Klopfer's work. Fraser's survey is called the Test of Science Related Attitudes (TOSRA). Fraser modified Klopfer's second theme, attitude toward scientists and scientific inquiry, into two separate themes, attitude toward science and scientists, and attitude toward scientific inquiry (Fraser, 1981). Therefore, TOSRA measures attitudes in the following seven scales:

1. The social implications of science
2. The normality of scientists
3. Attitude toward scientific inquiry
4. The adoption of scientific attitudes
5. The enjoyment of science lessons
6. Leisure interest in science
7. Career interest in science

Each attitude scale in TOSRA consists of ten statements, for a total of 70 statements. Five statements in each attitude scale are negative statements and the other five are positive statements. All questions use a 5-point Likert scale (Fraser, 1981).

Since the author found no studies calling the validity or reliability of TOSRA into question, the researcher selected it for the assessment for this study. A more thorough explanation of TOSRA is located in chapter three.

## **Robotics**

Robotics is about people creating systems that can interact with the world. Robot builders (roboticists) integrate subsystems like mechanical, electrical, and computers into a system that accepts inputs from the outside world to carry out appropriate actions (Jones, Seiger, & Flynn, 1999). Robotics is becoming a popular strategy for teaching elements of STEM for several reasons. Two reasons are the reduced cost of robotics kits and the ease of integrating them into the curriculum. The fact that students relate to robots like toys also helps to integrate robotics into the classroom (Barker & Ansoorge, 2007).

There are many robot kits available on the market. Two kits popular within education are the LEGO Mindstorms and the Parallax line of robot kits (Chambers & Carbonaro, 2003; Karp, Gale, Lowe, Medina, & Beutlich, 2010; Caldwell & Jones, 2011).

Mindstorms is a kit of robot parts (subsystems) that snap together like LEGOs. Unlike traditional LEGOs however, the Mindstorms parts include a series of sensors for detecting conditions in the world and motors for reacting. A programmable brain, which students program on a PC, interfaces the robot's sensors and motors to create an intelligent toy (Karp, Gale, Lowe, Medina, & Beutlich, 2010; Barker & Ansorge, 2007).

Parallax robot kits use a different approach to robotics. Instead of snapping together Parallax robot kits, students assemble the robots by bolting together metal parts according to the directions included in the kit. And whereas students program Mindstorm robots using a graphical interface, Parallax robot kits are programmed by writing text commands on a PC running the program editor (Caldwell & Jones, 2011).

Robotics is one way that to engage students in problem solving, teamwork, and creativity development. Robots fit within the model of experiential learning. In other words, students are active learners who learn by doing. This also makes robots a model of constructivist teaching (Barker & Ansorge, 2007).

Students find that they enjoy learning with robots because they have greater control over their learning experiences. In addition, they have the opportunity to expand their knowledge by applying what they already know. Students also like that they receive feedback that is immediate and informative (Barak & Zadok, 2009).

Robots are used as a part of many competitions. The competitions combine the excitement of a sporting event with an intellectual challenge (Johnson & Londt, 2010). They create authentic problems for teams of students to solve within constraints like limited time, parts, and budget. Competitions can increase a student's interest, giving him or her incentive to get involved and to consider careers in STEM (Dillon, 1995; Johnson & Londt, 2010).

Schools have a wide variety of robotics competitions from which to select. The competitions vary on grade level and the cost of entry. In fact, the cost of entry is one of the major deciding factors schools analyze when selecting a robotics competition. Some of the robotics competitions available include BEST (Boosting Engineering, Science, & Technology), several levels of FIRST (For Inspiration and Recognition of Science and Technology), Botball Educational Robotics, Robofest, NRC (National Robotics Challenge), and EARLY (Engineering and Robotics Learned Young) robotics (Johnson & Londt, 2010). Due to costs and the need for mentors, it is not uncommon to find that schools team with outside organizations (Johnson & Londt, 2010).

Cheryl Cobb (2004) of the Samuel Ginn College of Engineering, Auburn University, Alabama advocates for robotics as a practical approach to greater STEM exposure for middle and high school students. She notes that only 5 percent of high school students are preparing themselves for engineering careers. National robotics competitions like BEST get high school students excited about technology careers while they are still in high school and are still able to make future education and career choices.

When asked about the benefits of robotics competitions, Cobb notes that nearly 70 percent of students feel robotics competitions are a better way to learn STEM than their high school classes. More over, 80 percent of these students feel they learn more about engineering with robotics competitions than they could with robotics classes (Cobb, 2004).

The use of robotics in STEM education has been subject to multiple studies and found to be positive, as the following three cases will highlight. In the first example, Anita Welch investigated the effect that a robotics program called FIRST (For Inspiration and Recognition of Science and Engineering) had on high school student attitude toward science. The research took place in 2007 on nine schools in the Kansas City Metro area. Inventor Dean Kaman created

FIRST to be a national robotics challenge. Teams competing in US FIRST receive the year's competition rules and a kit of robot parts weighing 150 pounds in January each year. The teams then have six weeks to design, build, and program their robots. Regional competitions take place between FIRST teams in designated arenas across the United States beginning in late February. The national competition takes place between the regional winners in April (FIRST, *FIRST at a glance*, 2011; FIRST, *Events*, 2011).

Welch's research concluded that the FIRST robotic challenge had a small, but statistically significant impact in four of the seven attitudes toward science scales measured by TOSRA. First, after their 2007 involvement with FIRST, Welch's study found that the student mean score for attitude toward the social implications of science increased by eight percent. The student mean score for the normality of scientists was similar, and increased by 6.5 percent. The student mean score for attitude toward the use of scientific inquiry increased 5.8 percent after completing a FIRST robotics challenge and 9.4 percent for student scientific attitude at the completion (Welch, 2007). A deeper description of these results is located in the literature review of TOSRA.

The second study, by the University of Nebraska, examined the effects of robotics events on 141 middle school students. The students were from both urban and rural schools and took part in seven or eight robotics and geospatial activities. After the three hour event, students' beliefs in the importance of science, mathematics, robotics, and geospatial technologies increased, as measured by a 33 question attitude questionnaire.

According to this study, the mean score of student beliefs before the event was 4.09 on a five-point Likert scale. After the event, the mean of student beliefs was 4.34. The statistical significance as measured by a t-test was  $t(123) = 6.92$  for a significance level of less than 0.001 (Nugent, Barker, Grandgenett, & Adamchuk, 2010).



In the last example from 2002, the US FIRST organization requested that Brandeis University evaluate the impact the FIRST Robotics Challenge had on participating students. The study used surveys to compare FIRST robotics students to a compilation of all students who graduated over the previous four years (1999 to 2003) in New York City and Detroit. The survey used data of similar students found in a national dataset generated by the U.S. Department of Education of beginning postsecondary students called the Beginning Postsecondary Student Survey or BPS. Below are a few of the Brandeis findings (Melchior, Cohen, Cutter, & Leavitt, 2005).

1. Participants expressed positive changes in their interest in science and technology.
  - 89 percent claimed to have a better understanding of science and technology in their lives
  - 69 percent had an increased interest in pursuing a science or technology career after graduation.
2. Participants expressed positive changes in their problem solving skills.
  - 68 percent reported using PCs to search for and analyze data.
  - 67 percent stated they had learned how to use math in solving practical problems.
3. More participants reported graduating high school and attending college.
  - 99 percent of FIRST team members graduated from high school
  - 89 percent enrolled in college
  - 79 percent were still enrolled in college after four years
4. More participants reported taking STEM classes and STEM internships in college.
  - 87 percent reported taking at least one math course
  - 78 percent reported taking at least one science class
  - 51 percent reported taking at least one engineering class

### **BalloonSats**

BalloonSats are functioning models of satellites. Rather than being carried into orbit by rockets like satellites, BalloonSats travel into the mid-stratosphere beneath helium-filled weather balloons. From that vantage, the conditions a BalloonSat experiences are very similar to the conditions found in space. The literature on BalloonSats is extensive, but very little has been

concerned with an investigation of their effects. Two examples of descriptive literature comes from LaunchOIT at the Oregon Institute of Technology and BHALF, a NASA program at the Glenn Research Center. Both programs focus on middle and high school students, which is also the focus of this study.

## **LaunchOIT**

The Oregon Institute of Technology (OIT) developed their program as a K-12 outreach program to introduce students to STEM. LaunchOIT is a one-year program designed to meet the following Oregon state STEM-related education standards (Kansaku, Kehr, & Lanier, 2007):

### **SCIENCE**

#### **1. Physical Science:**

- Identify substances as they exist in different states of matter.
- Identify examples of gravity exerting force on an object.

#### **2. Earth and Space Science:**

- Understand changes occurring within the lithosphere, hydrosphere, and atmosphere of the Earth.
- Describe weather in measurable quantities including temperature, wind direction, wind speed, and precipitation.

#### **3. Scientific Inquiry:**

- Understand that scientific knowledge is subject to change based on new findings and results of scientific observation and experimentation.
- Describe the role of science and technology in local, national and global issues.
- Understand the relationship that exists between science and technology.

- Understand the process of technological design to solve problems and meet needs.

## MATHEMATICS

### 1. Calculations and estimations:

- Compute fluently and make reasonable estimates

### 2. Statistics and Probability

- Select and use appropriate statistical methods to analyze data.
- Formulate questions that can be addressed with data and collect, organize, and display relevant data to answer them.

## CAREER-RELATED LEARNING STANDARDS

### 1. Problem-solving:

- Apply decision-making and problem-solving techniques in school community, and workplace.

### 2. Communication:

- Demonstrate effective communication skills to give and receive information in school, community, and workplace.

### 3. Teamwork:

- Demonstrate effective teamwork in school, community, and workplace.

## TECHNOLOGY

1. Access, organize, and analyze information to make informed decisions, using one or more technologies.

2. Design, prepare, and present unique works using technology to communicate information and ideas.

(Kansaku, Kehr, & Lanier 2007, Table 1).

## **NASA Glenn Research Center/BHALF**

The Glenn Research Center (GRC) created BalloonSat High Altitude Flight (BHALF) as an annual competition for teams of four or more students in grades 9-12. Student teams enrolled in BHALF develop a proposal for the set of experiments that they would like to send into near space. The student proposals explain the experiment to be performed, how its data will be analyzed, and the controls for the experiment. The proposed BalloonSats can weigh no more than 750 grams nor have any dimension greater than 30 cm. GRC selects eight of the proposals for further development. Selected teams may receive up to \$1,000 to build their BalloonSat. Of the eight BalloonSat proposals, four teams are selected travel to GRC to observe the flight of their BalloonSat. GRC launches the remaining four BalloonSats; however, their teams are not present to observe the flight.

NASA believes participation in BHALF is one way to meet the following national education standards (BHALF, 2012):

### 1. National Science Teachers Association Standards

#### Science as inquiry

- Abilities necessary to do scientific inquiry
- Science and technology
- Abilities of technological design

### 2. International Technology Education Association Standards

#### Design

- Students will develop an understanding of the attributes of design

## **The Benefits of BalloonSats**

The use of BalloonSats in STEM education is a promising way to integrate all four aspects of STEM (Ellison, Giammanco, Guzik, Johnson, & Wefel, 2006). For example, LaunchOIT finds that students express excitement to participate and teachers ask to return the program the following year. According to LaunchOIT, the benefits of their BalloonSat program to elementary students are as follows (Kansaku, Kehr, & Lanier, 2007):

1. They are a method to teach and use inquiry
2. The data collect by students is real data and useful to more than just the students
3. Students see what it is like to be at a university
4. BalloonSats generate more questions than answers; therefore, they are not confirmation science experiments
5. Students learn STEM during the background research in preparation for their experiment
6. BalloonSats give teachers another opportunity to expose students to more science
7. BalloonSat are a tool for incorporating lessons in STEM, reading, writing, and social science

The most significant research on BalloonSats comes from the university level. According to Chris Koehler (2003), BalloonSats are a hands-on approach to teaching STEM to students through a project that they find interesting. College students become more excited about their future and find increased value in the classes that they are taking. Koehler finds that over 50 percent of his students get involved with research projects earlier than typical for university students. He finds more students express a desire to become an engineer or scientist because of their BalloonSat experience (Koehler, 2003; Kennon, Roberts, & Fuller, 2008).

Synder's (n.d.) study at Taylor University's High Altitude Research Program (HARP) investigated the effects of high altitude ballooning on students. The study involved 141 undergraduate students in three classes (two introductory astronomy classes and one engineering principles class) during the 2007-2008 school year. In the Taylor study, students designed BalloonSats, participated in their flights, and analyzed the data collected.

Taylor University developed and tested the HARP Assessment Instrument and the Balloon Launch Observation Instrument for this study. The HARP Assessment Instrument made measurements on students in the following areas.

1. Intrinsic motivation
2. Valuing science
3. Application knowledge
4. Metacognitive processes
5. Cognitive skills
6. Content knowledge

Intrinsic motivation related to students' interest in exploring the unknown. So for example did they express a curiosity, have a desire to be challenged, and willing to cooperate in a project of exploration. Measures of application knowledge investigated students' ability to problem solve, to build prototypes, and to document results. To measure a student's metacognitive processes, the Taylor assessment measured each student's ability to plan and monitor their progress in learning tasks. The investigation of content knowledge focused on a student's ability to launch a weather balloon.

The reliability of the HARP Assessment Instrument was determined to have a Cronbach alpha of 0.976 pretest and 0.965 posttest. Validity was determined by comparing the mean scores of engineering students and astronomy students. Taylor University researchers believe that engineering students should have higher scores in content knowledge, valuing science, and intrinsic motivation than astronomy students. An evaluation of the assessments did find that engineering students did indeed have higher mean scores in all three areas than astronomy students.

After completion of the BalloonSat program, results of the study indicated that valuing science did not change for students in the study (pretest mean = 4.07, posttest mean = 4.16,  $t = -1.19$ , significance = 0.236). The study suggests one reason valuing science did not increase is

because students will not think that the near space activity modeled real science unless it was taught in class. However, the Taylor study did find that intrinsic motivation of the students increased after completing the BalloonSat program (Snyder n.d.).

### **Summary**

This chapter briefly discussed the changing nature of the American economy. Due to the increasing recognition of the importance that STEM plays in industry and to the difficulty that companies claim they have in hiring qualified Americans, increased numbers of high technology industries are taking advantage of the H-1B visa system. However, according the DARPA, the increased relying on foreign-born workers could represent a potential long term risk to the United States. Organizations like DARPA encourage industry and the government act to increase the number of STEM trained American workers.

This chapter also described how teachers use several approaches to teaching STEM. These include methods like inquiry-based learning and project-based learning. These approaches incorporate elements of constructivism and should engage students' interest so that they will learn science content more deeply. Attitude is another factor along with engagement that can increase student achievement. As a result, both are important topics in education research.

Robotics is a popular tool for teaching STEM in middle and high school. A more recent addition is the BalloonSat, a simulation of a satellite. A BalloonSat is a science experiment and if it incorporates programmable logic, it has much in common with robotics. One area they do differ however is that BalloonSats allow students to explore near space, a region of the middle stratosphere which has the look and feel of outer space.

One assessment used to measure attitude toward science is the Scientific Attitude Inventory, or SAI. Initially developed in 1970 by Moore, the SAI is one of the most popular assessments for measuring student attitudes. In response to criticism of SAI, its creators modified it into the SAI II. However, analysis of the new assessment gives reason to believe the SAI II is not as suitable for measuring attitudes as the authors initially intended. Therefore, it appears the Test of Science Related Attitudes, or TOSRA is a more accurate assessment tool for student attitude.



## CHAPTER III

### METHODS

This study measured the impact of the researcher's BalloonSat project on student attitudes toward science. Since there are many facets to attitude, this study measured Fraser's (1981) seven categories of attitude toward science using the Test of Science Related Attitudes (TOSRA) survey. In addition to the BalloonSat's effect on attitude toward science, this study also investigated the effects of gender, since gender has a history of influencing the effects of education reform. Therefore, this study also searched for an interaction between gender and BalloonSats. The collection and analysis of this study's data used both qualitative and quantitative methods.

Measuring changes in student attitude toward science required the use of ANCOVA. The dependent variable was student scores in each of the seven attitudes after the completion of the BalloonSat project. The covariate was the pretest score of the same attitude and the factor was membership in the BalloonSat group. A second ANCOVA, but this one including an interaction term between gender and BalloonSat, identified possible gender differences in the BalloonSat project.

This study expanded its findings by including applicable portions of the focus group transcript. Student comments help clarify why students responded to the BalloonSat project as they did. The result is the study's increased richness due to the inclusion of a qualitative analysis.

### **Primary Research Questions**

1. Do grades seven – ten students have a statistically significant greater positive attitude toward the social implications of science after building a BalloonSat and analyzing its data (TOSRA S scale)?
2. Do grades seven – ten students have a statistically significant greater positive attitude toward the normality of scientists after building a BalloonSat and analyzing its data (TOSRA N scale)?
3. Do grades seven – ten students have a statistically significant greater acceptance of scientific inquiry as a way of thought after building a BalloonSat and analyzing its data (TOSRA I scale)?
4. Do grades seven – ten students have a statistically significant greater adoption of scientific attitudes after building a BalloonSat and analyzing its data (TOSRA A scale)?
5. Do grades seven – ten students have a statistically significant greater enjoyment of science experiences after building a BalloonSat and analyzing its data (TOSRA E scale)?
6. Do grades seven – ten students have a statistically significant greater interest in science and science-related activities after building a BalloonSat and analyzing its data (TOSRA L scale)?
7. Do grades seven – ten students have a statistically significant greater interest in pursuing a career in science after building a BalloonSat and analyzing its data (TOSRA C scale)?

### **Definition of Variables**

Independent Variable: grade seven - ten students participating in the BalloonSat project and divided by gender (which is also an independent variable).

Dependent Variables:

1. Attitude toward the social implication of science
2. Attitude toward scientists
3. Attitude toward scientific inquiry
4. Adoption of scientific attitudes
5. Enjoyment of science lessons
6. Leisure interest in science
7. Career interest in science

### **Secondary Research Question**

Is there a difference in attitude toward science between male and female students after building a BalloonSat and analyzing its data?

### **Power Analysis**

In order to determine an adequate sample size, the following power analysis was performed using G\*Power v3.1.3. Assumptions for the power analysis is that the BalloonSat has a moderate effect ( $f = 0.25$ ) on attitude toward science. The power study used standard conditions of research in the social sciences, namely a five percent chance of committing a Type I error ( $\alpha = .05$ ) and a 20 percent chance of committing a Type II error ( $\beta = 0.20$ ).

**Table 1. G\*Power Analysis of Study Design (Faul, Erdfelder, Lang, & Buchner, 2007).**

F tests - ANCOVA: Fixed effects, main effects and interactions			
Analysis:	A priori: Compute required sample size		
Input:	Effect size f	=	0.25
	$\alpha$ err prob	=	.05
	Power (1- $\beta$ err prob)	=	0.80
	Numerator df	=	1
	Number of groups	=	5
	Number of covariates	=	1
Output:	Noncentrality parameter $\lambda$	=	8.0000000
	Critical F	=	3.9188157
	Denominator df	=	122
	Total sample size	=	128
	Actual power	=	0.8012613

Because G\*Power rounds the sample size calculation up to a meaningful whole number, the actual power of the study's statistical test can be greater than the minimum accepted power. Therefore, the power study concludes that by enrolling 128 students in this study, it has an 8.01 percent chance of avoiding accepting a false null hypothesis.

### **Definition of Participating Schools**

#### **Treatment Group**

The treatment group includes those students who built a BalloonSat from the kit of parts provided by the researcher. The researcher initially enlisted the help of amateur radio operators to identify local junior and senior high school teachers who might be interested in participating in this study. To ensure the study would have an adequate sample of students, the researcher posted a second request for volunteers in the Kansas Association of Teachers of Science Bulletin. Eventually, the study was able to enroll 18 teachers. At the researcher's request, each teacher found approximately five students to construct the BalloonSat and an equal number of students to act as a control group. Teachers also attempted to divide the student sample equally between male

and female students. Each participating teacher received the BalloonSat kit described in Appendix Q. After completion and testing, classrooms mailed their BalloonSats back to the researcher for its high altitude balloon flight. Table 2 is a brief description of the schools who initially committed to participating in the study.

**Table 2: Details of Participating Schools**

School	Junior/Senior High	Urban/Suburban/Rural	Number of Students Participating	Number of BalloonSats
BCS	Junior	Rural	16	2
BSI	Senior	Urban	12	1
CAPS	Senior	Suburban	25	2
DMS	Junior	Rural	24	3
HSA	Senior	Urban	8	1
JHMS	Junior	Rural	10	1
HGSHS	Senior	Urban	unknown	1
HTCS	Junior	Suburban	24	2
KCJHS	Junior	Urban	12	1
KMS	Junior	Rural	7	1
MJHS	Junior	Rural	17	1
MJSHS	Junior	Rural	40	3
OSHS	Senior	Suburban	10	1
RHS	Senior	Suburban	0	1
RJHS	Junior	Urban	0	1
TMS	Junior	Urban	39	4
TP	Senior	Urban	20	3
UHS	Senior	Rural	48	2

The schools BSI, HGSHS, KMS, MJHS, RJHS, RHS, and TP dropped out of the study before submitting a BalloonSat.

This study used a quasi-experimental design, in which students self-selected which group, the treatment group or the control group, to join. TOSRA surveys measured student attitudes towards science before the start of the study (pre-survey) and at its conclusion (post-survey).

### **Comparison Group**

The comparison group consisted of students from the same school and in most cases, the same teachers as the treatment group. The comparison group of students did not participate in the BalloonSat project. Students making up the comparison group were asked by teachers to participate and parents consented by signing the study approval form.

Independent Variable: grade seven - ten students who did not participate in the BalloonSat project and divided by gender (which is also an independent variable).

Dependent Variables:

1. Attitude toward the social implication of science
2. Attitude toward scientists
3. Attitude toward scientific inquiry
4. Adoption of scientific attitudes
5. Enjoyment of science lessons
6. Leisure interest in science
7. Career interest in science

### **Research Locations**

This study included students from schools in Kansas, Michigan, Texas, Washington, and two provinces in Canada (Saskatchewan and Alberta). Eighteen schools initially agreed to participate and five dropped out before completion of the study. The schools were located in a mix of urban, suburban, and rural communities. All were public schools except one.

## **Research Time Period**

The researcher designed the study during the fall 2011 semester. After receiving approval for the study, the researcher spent the remainder of the fall completing the following tasks:

1. Obtaining approval for the study from the advisory committee and KU Human subjects
2. Locating teachers and classrooms
3. Assembling the BalloonSat kits
4. Setting up an email list (BalloonSat\_Research in Yahoo Groups) for communication between study subjects and teachers
5. Writing and photocopying kit directions and attitude instruments
6. Collecting demographics on each participating classroom

The researcher mailed the BalloonSat kits and paper copies of the TOSRA surveys to participating teachers in early December 2011. After school began again in January 2012, students completed the attitude assessment (TOSRA) as a pre-survey prior to unpacking their BalloonSat kit. Designing, building, programming, and testing the BalloonSats took place during the first four months of the spring 2012 semester. In March, the development of an online version of the TOSRA was completed. The Qualtrics account owned by the University of Kansas provided the survey software. Beginning in April, the researcher identified the launch sites and chase crews for the BalloonSats. Since the BalloonSat launches took place near the University of Kansas, the researcher contacted amateur radio operators living in eastern Kansas for help launching, chasing, and recovering the weather balloons. Launch predictions were made daily beginning the Monday before the flights (which took place on Saturdays and Sundays) using the online Balloon Track (BallTrak) flight prediction program. The researcher attached the



BalloonSats to their assigned balloon string one or two days prior to their launch. Table 3 briefly describes the four balloon flights used to complete this study.

**Table 3. Balloon Launches**

Date	Altitude	BalloonSats (number of BalloonSats)
March 31, 2012	77,400 feet	DMS (3), MJHS (3), HSA
April 8, 2012	66,400 feet	TMS (4), CAPS (2)
April 28, 2012	83,879 feet	JHJH, HTCS (2), KCJHS, reflw TMS(4), and CAPS (2)
May 5, 2012	81,605 feet	Reflew HTCS (2) and KCJHS

Four 1000 gram (1000 grams is the weight of the balloon) weather balloons were purchased for the flights. After an unacceptable second flight, a 1200 gram balloons was used for the second flight and 1500 gram balloons were used for the third and fourth. Six T size tanks of helium (each T-tank holds 291 cubic feet of helium) were required to launch the 20 BalloonSats built for this study. The study mailed BalloonSats back to the participating schools within two days of recovery, except in the case of the second launch because of the unacceptable performance of its balloon. After receiving the BalloonSats, students spent two weeks downloading and analyzing the results of the BalloonSat mission. By early May, the researcher received permission to use students at HSA and HTCS for the focus group’s convenience samples. Student BalloonSat teams wrote one report per BalloonSat and completed the online version of TOSRA created by the researcher. Students completed the last post-surveys by the end of May. The focus group meetings took place at HSA on May 11, 2012 and HTCS on May 18, 2012. Data analysis of student surveys and interviews took place during May 2012.

## Survey Sampling

After writing the parental permission letter, the researcher submitted it to the Human Studies Committee Lawrence for their approval. Nineteen teachers and principals volunteered their classrooms for the study. Then the teachers and principals sent the approved parental permission letter to their students. In every case, parent approved their child's participation by signing and returning the permission form. These students comprised the final sample for this study.

A total of 318 students completed the TOSRA pre-survey and only 138 completed both the pre and post-survey. There are several reasons for the reduced number of students who completed the post-survey. First, five teachers dropped their classrooms out of the study after completing the pre-surveys but before beginning the BalloonSats. Two classrooms began work on their BalloonSat before quitting and never completing the post-surveys. The reason given for dropping out was the amount of work required to complete the project. The BalloonSat project was more difficult for teachers unfamiliar with soldering and programming that could not locate outside help. The description of the study's final samples for both surveys and details describing the schools in the study is shown below.

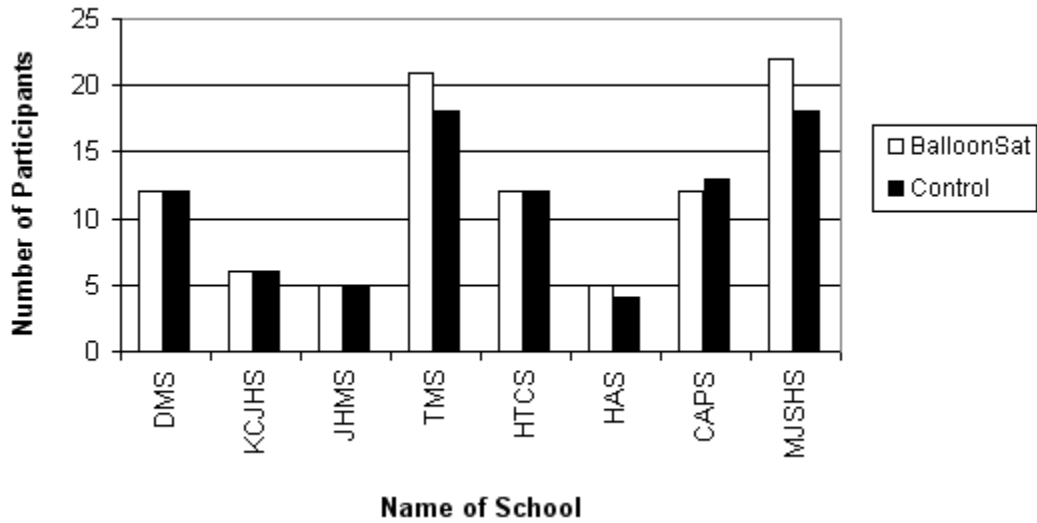
**Table 4: Detail of School Participation in Study**

<b>Name of School</b>	<b>Number of Students</b>	<b>Percentage of Students</b>
TMS	39	21.3
CAPS	25	13.7
DMS	24	13.1
KCJHS	12	6.6
HTCS	24	13.1
HSA	10	5.5
JHMS	9	4.9
MSJHS	40	21.9

**Table 5: Detail of BalloonSat Project Membership of Students Participating in Pre-Survey**

<b>Member of BalloonSat Team</b>	<b>Number of Students</b>	<b>Percentage of Students</b>
Yes	95	51.9
No	88	48.1

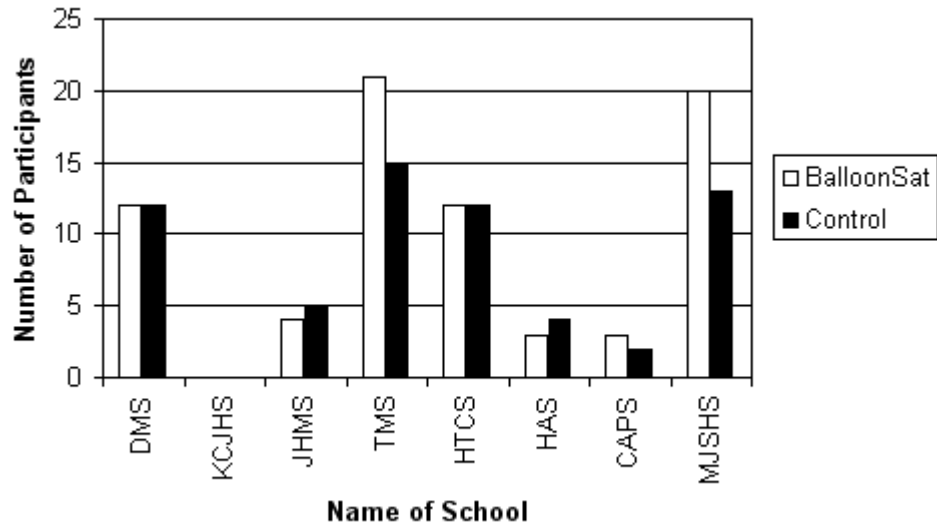
**Figure 1: Schools and Number of BalloonSat and Non-BalloonSat Students Participating in Pre-Survey**



**Table 6: Detail of BalloonSat Project Membership of Students Participating in Post-Survey**

Member of BalloonSat Team	Number of Students	Percentage of Students
Yes	75	54.3
No	63	45.7

**Figure 2: Schools and Number of BalloonSat and Non-BalloonSat Students Participating in Post-Survey**



**Table 7: Detail of Gender of Students Participating in Pre-Survey**

Gender	BalloonSat		Control	
	Frequency	Percent	Frequency	Percent
Male	50	27.3	48	26.2
Female	45	24.6	40	21.9

**Table 8: Detail of Gender of Students Participating in Post-Survey**

Gender	BalloonSat		Control	
	Frequency	Percent	Frequency	Percent
Male	36	26.1	32	23.2
Female	39	28.3	31	22.5

A limitation of this study was the inability to use random sampling. The study also was limited to schools with teachers willing to include a BalloonSat project into the curriculum. Sampling was further limited classrooms dropping out after the beginning of the study.

### **Survey Participants**

#### **BalloonSat Participants**

The typical team of students building a BalloonSat team consisted of five students. Ninety-five students participated in the pre-survey and 75 of the same group completed the post-survey.

#### **Control Group Participants**

Teachers selected a sample of non-participating students from their classroom as the control group. The control group consisted of volunteer students from grades seven – ten. Eighty-

eight control group students participated in the pre-survey and 63 of them also completed the post-survey.

### **Procedures**

This study followed the procedures outlined below.

1. November 2011: Received approval for human subjects research from the University of Kansas
2. November 2011: Began contacting teachers and principals and asking for permission to conduct the study in their classrooms. Contact made through amateur radio operators and an announcement in the Kansas Association of Teachers of Science newsletter.
3. November/December 2011: Received participation agreements from schools agreeing to participate in the study. A copy of the agreement is located in Appendix F.
4. December 2011: Researcher assembled paper copies of TOSRA, parent permission slips, and BalloonSat kits and mailed them to participating teachers. Teachers distributed the parent permission slips to their students and mailed the signed copies back. A copy of the parent permission slip is located in Appendix G.
5. December 2011/January 2012: Teachers returned TOSRAs and parent permission slips through the mail.
6. January/April 2012: Students built BalloonSat kits. After testing, schools mailed the completed BalloonSats to the researcher for flight.
7. March 2012: Researcher developed an online version of the TOSRA and six teachers tested it.

8. March-May 2012: BalloonSats launched on weather balloons. After recovery, researcher mailed each BalloonSat back to its classroom of origin so students could analyze their results.

9. May 2012: Students took the post-survey.

10. May 11, 2012: Focus group meeting conducted with three HSA students. The researcher recorded and transcribed the interview.

11. May 18, 2012: A second focus group meeting held with nine students at HTCS. The researcher recorded and transcribed the interview.

## **Quantitative Study**

### **TOSRA**

The Test of Science Related Attitudes (TOSRA) permits researchers and educators to measure how well students meet the attitudinal goals of science education. Barry Fraser (1981) did not design TOSRA for individual assessment. Rather, TOSRA evaluates the attitude toward science for a population, like an entire classroom, through pretest and posttest surveys. In addition, TOSRA creates a profile of attitude scores, not just a single attitude measurement. This is similar to looking at an electromagnetic spectrum and therefore is more meaningful. Students are likely to complete the TOSRA because they can quickly answer all the questions. Students also are likely to be honest in their answers because they know their results are anonymous. While there is no time limit for completing the TOSRA, Fraser expects students to spend between 25 and 45 minutes completing the survey (Fraser, 1981).



## **History of TOSRA**

Barry J. Fraser of Macquarie University, Australia developed the first version TOSRA, which measured student attitudes towards science using five attitude scales. After a test for validation on over 1,000 grade seven students, Fraser made four additional changes to the assessment as described below (Fraser, 1978).

1. Fraser added two additional attitude scales so that the attitudinal scales measured by TOSRA matched the scales of attitude toward science as described by Leopold Klopfer (Klopfer, 1971). The two new scales were the Normality of Scientists and Career Interest in Science.
2. Fraser shortened the directions for TOSRA into a single page.
3. Fraser redesigned each attitude scale for ten statements. However, during the next field test, each scale consisted of with 14 statements so an analysis of student responses permitted the ten best statements to be identified and retained for the final version of TOSRA.
4. Fraser field tested TOSRA on grade seven – ten students.

The 1977 field test of TOSRA involved 1,337 grade seven – ten students in Sydney, Australia spanning 44 classes and 11 schools. The schools selected for the field test provided a broad range of student types. There were about an equal numbers of boys and girls included in the field test (Fraser, 1978).

**Table 9: Reliability of TOSRA as measured by Cronbach's Alpha (Fraser, 1981)**

Grade	Range	Mean
7	0.66-0.93	0.82
8	0.64-0.93	0.80
9	0.69-0.92	0.81
10	0.67-0.93	0.84

In addition, Fraser found that the intercorrelations between TOSRA's seven attitude scales ranged from .10 to .59 with a mean of .33. This is considered a low correlation between scales. Fraser also found that the three scales with the greatest correlations were Enjoyment of Science Lessons, Leisure Interest in Science, and Career Interest in Science. These correlations are not surprising considering that students with high interests in science careers are expected to enjoy science lessons and want to have science related hobbies.

### **Attitude Scales of TOSRA**

TOSRA measures seven distinct attitudes toward science, based on the attitude scales developed by Leopold Klopfer in 1971.

**Table 10: Klopfer's Six Categories of Attitude toward Science (Klopfer, 1971)**

- H1: The manifestation of favorable attitudes towards science and scientists
- H2: The acceptance of scientific inquiry as a way of thought
- H3: The adoption of "scientific attitudes"
- H4: The enjoyment of science learning and experiences
- H5: The enjoyment of science learning experiences
- H6: The development of interest in pursuing a career in science

TOSRA splits category H1 into two scales, normality of scientists and attitude to scientific inquiry.

**Table 11: TOSRA's Seven Categories of Attitudes toward Science (Fraser, 1981)**

Scale S: Social implications of science  
Scale N: Normality of scientists  
Scale I: Attitude to scientific inquiry  
Scale A: Adoption of scientific attitudes  
Scale E: Enjoyment of science lessons  
Scale L: Leisure interest in science  
Scale C: Career interest in science

TOSRA contains ten statements per attitude scale, for a total of 70 statements in the survey. Students read each statement and select the response that he or she most agrees with using the following five-point Likert scale:

SA – Strongly Agree  
A – Agree  
N – Not Sure  
D – Disagree  
SD – Strongly Disagree

Half of the TOSRA survey statements are positive statements and five are negative statements. All items are scored to give positive answers the higher score. In accordance to directions in the TOSRA handbook, invalid or blank statements are scored three points.

**Table 12: Point Allocation for TOSRA Items**

Answer	Positive Statements	Negative Statements
SA	5	1
S	4	2
N	3	3
D	2	4
SD	1	5

Attitude scores are the sum of the point score of each response. The scores for each attitude scale ranges from 10 to 50. The researcher then calculates the mean score for each scale from all of the student assessments.

### **Statistical Methods**

Quantitative analysis of the surveys was performed using statistics package SPSS version 20. The researcher reviewed the descriptive statistics of the data prior to the analysis of the data in order to understand the structure of the data collected.

Due to the inability to randomly sample, students will likely group themselves by their initial interest, thereby creating a bias in the survey data. It is therefore necessary to perform an analysis of covariance (ANCOVA) on the survey data to account for this possible bias. The ANCOVA determines whether the difference between the means of the dependent variables for two or more independent variables is statistically different from one another, when controlling for the covariates. The level of significance chosen for the dependent variables, or p-values, in this

study was an alpha level of .05. In this study, p-values less than or equal to .05 are considered significant.

1) Do grades seven – ten students have a statistically significant greater positive attitude toward the social implications of science after building a BalloonSat and analyzing its data (TOSRA S scale)?

In accordance to the TOSRA handbook, questions 1, 15, 29, 43, and 57 are positive statements and questions 8, 22, 36, 50, and 64 are negative statements and therefore reversed scored. An ANCOVA between the pre and post-survey measured the changes in student mean scores. A student interview with a convenience sample investigated any detected differences.

2) Do grades seven – ten students have a statistically significant greater positive attitude toward the normality of scientists after building a BalloonSat and analyzing its data (TOSRA N scale)?

In accordance to the TOSRA handbook, questions 9, 23, 37, 51, and 65 are positive statements and questions 2, 16, 30, 44, and 58 are negative statements and therefore reversed scored. An ANCOVA between the pre and post-survey measured the changes in student mean scores. A student interview with a convenience sample investigated any detected differences.

3) Do grades seven – ten students have a statistically significant greater acceptance of scientific inquiry as a way of thought after building a BalloonSat and analyzing its data (TOSRA I scale)?

In accordance to the TOSRA handbook, questions 3, 17, 31, 45, and 59 are positive statements and questions 10, 24, 38, 52, and 66 are negative statements and therefore reversed scored. An ANCOVA between the pre and post-survey measured the changes in student mean scores. A student interview with a convenience sample investigated any detected differences.

4) Do grades seven – ten students have a statistically significant greater adoption of scientific attitudes after building a BalloonSat and analyzing its data (TOSRA A scale)?

In accordance to the TOSRA handbook, questions 4, 18, 32, 46, and 60 are positive statements and questions 11, 25, 39, 53, and 67 are negative statements and therefore reversed scored. An ANCOVA between the pre and post-survey measured the changes in student mean scores. A student interview with a convenience sample investigated any detected differences.

5) Do grades seven – ten students have a statistically significant greater enjoyment of science experiences after building a BalloonSat and analyzing its data (TOSRA E scale)?

In accordance to the TOSRA handbook, questions 5, 19, 33, 47, and 61 are positive statements and questions 12, 26, 40, 54, and 68 are negative statements and therefore reversed scored. An ANCOVA between the pre and post-survey measured the changes in student mean scores. A student interview with a convenience sample investigated any detected differences.

6) Do grades seven – ten students have a statistically significant greater interest in science and science-related activities after building a BalloonSat and analyzing its data (TOSRA L scale)?

In accordance to the TOSRA handbook, questions 6, 20, 34, 48, and 62 are positive statements and questions 13, 27, 41, 55, and 69 are negative statements and therefore reversed scored. An ANCOVA between the pre and post-survey measured the changes in student mean scores. A student interview with a convenience sample investigated any detected differences.

7) Do grades seven – ten students have a statistically significant greater interest in pursuing a career in science after building a BalloonSat and analyzing its data (TOSRA C scale)?

In accordance to the TOSRA handbook, questions 14, 28, 42, 56, and 70 are positive statements and questions 7, 21, 35, 49, and 63 are negative statements and therefore reversed scored. An ANCOVA between the pre and post-survey measured the changes in student mean scores. A student interview with a convenience sample investigated any detected differences.

### **Secondary Research Question**

Is there a difference in attitude toward science between male and female students after building a BalloonSat and analyzing its data?

This question investigated how gender may affect attitude toward science for students completing the BalloonSat project. Analysis of data for this question involves searching for an interaction between BalloonSat group and gender. An F-ratio with a significance of .05 or less ( $p < .05$ ) will be considered as evidence for a gender effect on the BalloonSat project.

## Qualitative Study

### Focus Group Meeting Participants

The first thirty minute focus group meeting took place at the HSA on May 11, 2012. Since this occurred near the end of the school year, many students in this class were skipping classes. A total of three students from the school agreed to participate in the focus group meeting. The researcher conducted a second focus group meeting at HTCS on May 18, 2012. A total of nine students participated in the second focus group meeting. The goal of the focus group meeting was to gather additional input on the effectiveness of the BalloonSat project on student attitude toward science. Students involved in the focus group meeting had the opportunity to review the transcripts created by the researcher. Below are listed the questions asked of the participating students. The researcher recorded and transcribed the discussion.

### Figure 3: Focus Group Questions

1. Did the BalloonSat project change your impression of the usefulness of science?
  - a. Is science answering important questions? What are some examples of important questions?
  - b. Is the cost of science appropriate for its benefit? Too expensive, just right, good bargain?
  - c. What kinds of risks does science present to society? Very few, an acceptable risk, too risky?
  
2. Did the BalloonSat project change your view of what kind of person can be a scientist?
  - a. If you live next door to a scientist, what would this person look like?
  - b. What kinds of activities would this person do after work?
  - c. What kind of family would this person have?



3. Did the BalloonSat project change your belief in the usefulness of science in discovering knowledge?
  - a. Are there any important questions that science cannot answer, given enough time? Examples?
  - b. Are there any questions it is best that science doesn't investigate? Examples?
  - c. Are there some questions best left as mysteries? Explain.
  
4. Did the BalloonSat project change your opinion regarding the importance of being open-minded and ready to revise your thoughts and plans?
  - a. Did you frequently know best how to build the BalloonSat?
  - b. Did anyone on your team convince you that they had a better idea? Examples?
  - c. Where most of your team pretty clueless about the BalloonSat? Examples?
  - d.
  
5. Did the BalloonSat project change how you view your science classes?
  - a. What science classes are you know planning to take? Why?
  
6. Did the BalloonSat project change the hobbies and activities you wish to pursue?
  - a. What are your current hobbies?
  - b. What hobbies do you want to start now?
  - c. What science museums have you visited before?
  - d. Which science museums do you want to visit in the next few years? Why?
  - e. If there is a science club at school, do you plan to join it? Why?
  - f. If you have access to science-related after-school programs, so you plan to join them? Why?
  
7. Did the BalloonSat project change your plans for after graduation?
  - a. How would you describe how your plans have changed?
  
8. Did males and females work differently on the BalloonSat project? Examples?

### **Qualitative Analysis of Focus Group Meeting Data**

Prior to the analysis of the focus group transcript, multiple copies of the transcript were saved as a text file (a file without formatting information). The transcript was read several times

to identify categories spontaneously created by the students in the focus group, and not created by the researcher. The researcher identified the following three categories within the transcript.

1. Science
2. BalloonSat
3. Enjoyment

Next, the transcript was searched for repeated themes appearing within each category. Themes, according to Creswell (2007) are the key issues that appear in the transcript. Themes in the transcript occurred where similar words and phrases appeared in conjunction with one another. In addition, a search was made for instances where themes appeared in conjunction with one another. When two themes did appear frequently with each other, the researcher created a more encompassing theme to replace the two.

Next, Weft QDA analyzed the focus group transcript. Weft QDA codes text by marking portions as belonging to Weft QDA categories. The categories used in WEFT QDA are the categories and themes previously found in the transcript. Category names are meaningful words or short sentences as recommended by the Weft QDA Users Guide (Fenton, 2006). In addition to coding the transcript by the discovered themes and categories, gender of the speaker was used to code the transcript. A list of the Weft QDA categories is located in Appendix H. After coding the transcript, each Weft QDA category was related to the TOSRA attitude scale it most accurately represented. Combined with the coding, qualitative analysis of the transcript further explains the findings of the survey.

## **Conclusion**

This chapter describes the qualitative and quantitative methods used in this study. The ANCOVA used to analyze changes in the pre and post-survey results was described along with the ANCOVA used to analyze possible gender effects. Both the pre and post-surveys are Fraser's

TOSRA. The results of the power study using G\*Power was described. The results indicated that a minimum of 111 students are required in order for the study to have an 80 percent chance of finding a medium effect. The schools and student populations were described along with how that population changed over the course of the study. Finally, the four balloon launches used to launch the study's BalloonSats was described.

## **Chapter IV**

### **Results**

The researcher conducted this study in order to search for possible effects that a BalloonSat project has on student attitude toward science. Past studies have demonstrated that robotics have positive effects on student attitudes toward science. Since the BalloonSat activity in this study shares many of the features of robotics, the researcher assumed that the BalloonSat project would have a similar effect. Research has shown that gender is at times a factor contributing to success of science programs. Therefore, it also was necessary to investigate the influence of gender on the BalloonSat project.

### **Research Design**

At the beginning of this study, 183 participating students recorded their pre-survey Test of Science Related Attitudes (TOSRA) responses on a paper copy provided by the researcher. Later in the study, the researcher created an online version of TOSRA for the participating students to record their post-survey results. At the end of the study, the researcher entered student results into an Excel 2003 file. Excel then generated student scores in the seven TOSRA attitudinal categories. The analysis of the Excel file was accomplished using SPSS version 20 and included descriptive statistics, means, variances, and standard deviations.

The control and treatment groups are not assumed equal since student were not randomly assigned to them. As a result, it was necessary to perform an analysis of covariance (ANCOVA)

on the data. ANCOVA is a statistical method that removes the bias resulting from students self-selecting the groups they wish to join. For the ANOVA, the pre-survey scale scores were the covariate in this analysis, treatment group was the factor, and the post-survey scores were the dependent variable. Following the standard of other studies in the behavioral science, an alpha level of .05 was the level of statistical significance. In addition, the researcher was satisfied accepting a five percent chance that any findings discovered in this study were the results of sampling error and not from a true finding. Therefore, any p-value less than or equal to .05 was considered statistically significant in this study.

While the researcher believes that a quantitative analysis of this data collected in this study is informative, the inclusion of a qualitative analysis adds an additional richness to the results. Student comments made during the focus group meetings adds the student voice and helps to clarify the student experience.

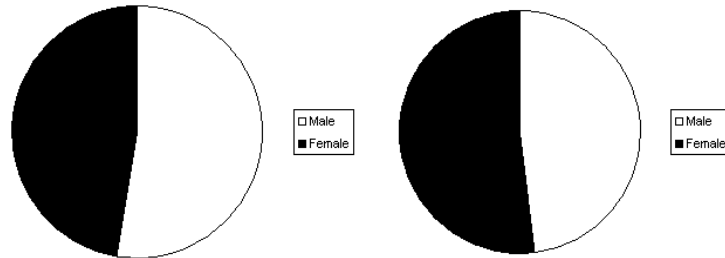
Based upon the analysis of the quantitative and qualitative data, the researcher is reporting whether the participation of grade 7-10 students in a BalloonSat project created a significantly greater increase in their attitude toward science than not participating in a BalloonSat project.

### **Sample Characteristics**

One hundred eighty three students completed the pre-survey and 138 students completed the post-survey, for a 75.4 percent participation rate. The non-BalloonSat, or control group consisted of 88 students in the pre-survey and 63 students in the post-survey. The BalloonSat or treatment group consisted of 95 students in the pre-survey and 75 students in the post-survey. Figure 4 displays the gender of the students participating in the BalloonSat and non-BalloonSat groups.

**Figure 4: Student Gender**

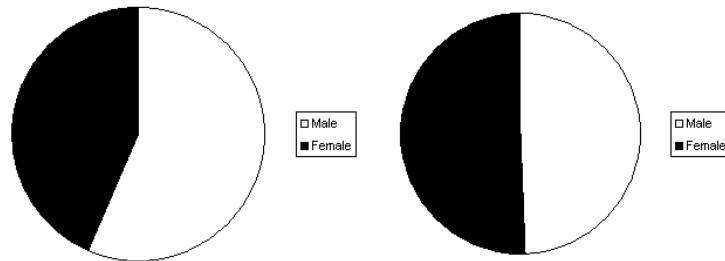
**BalloonSat Students**



**Pre-Survey Respondents (N = 95)**

**Post-Survey Respondents (N = 75)**

**Control Students**



**Pre-Survey Respondents (N = 88)**

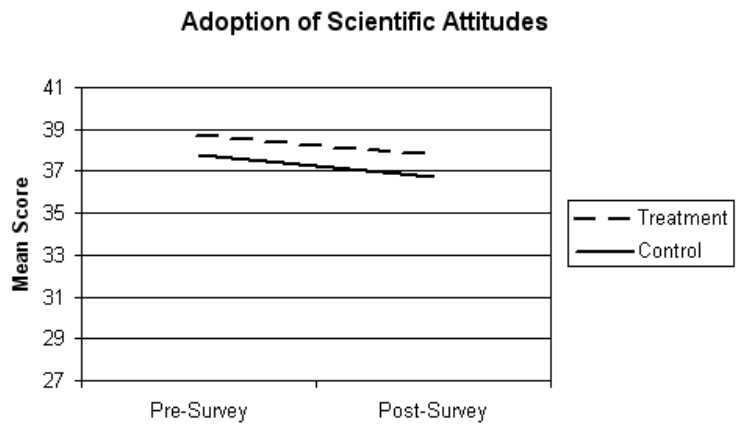
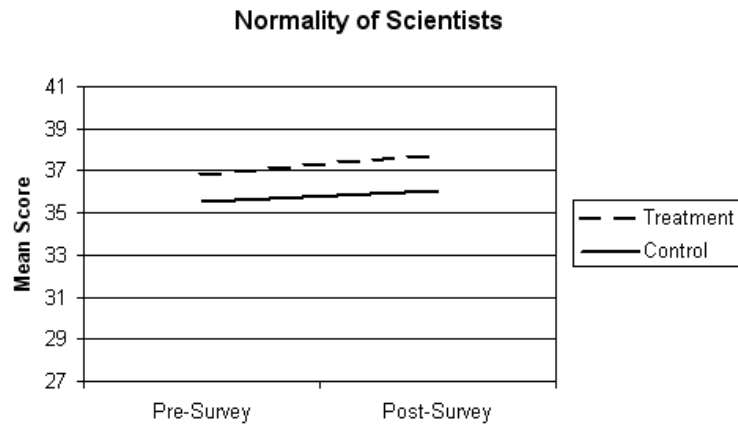
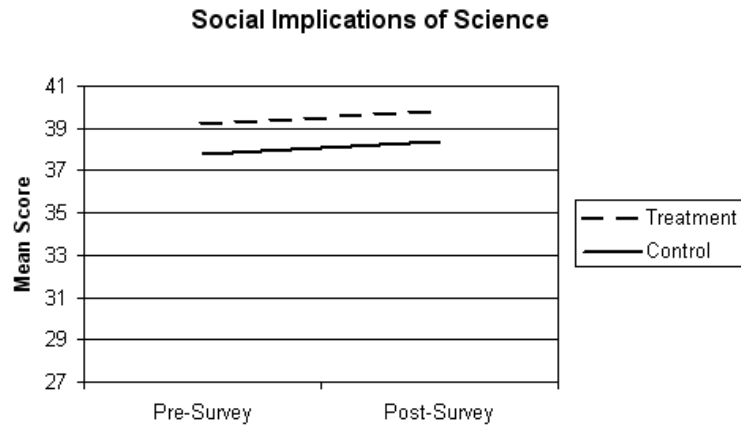
**Post-Survey Respondents (N = 63)**

SPSS generated descriptive statistics on the research dataset in order to develop a picture of the results of the BalloonSat project. The number of participating students, mean scores for each category of attitude, and standard deviations appears in table 13 and figure 5.

**Table 13: Pre and Post-survey Descriptive Statistics**

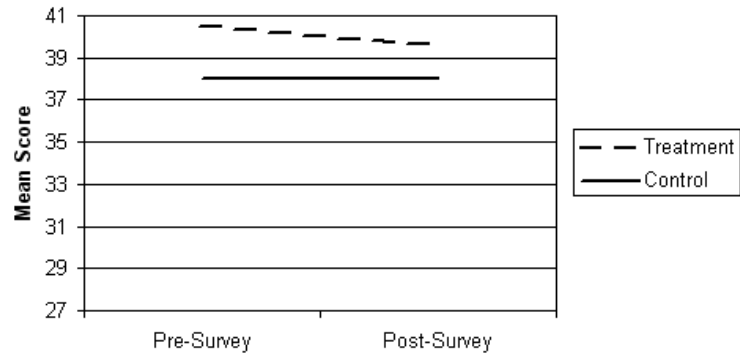
Category	Pre			Post		
	N	M	SD	N	M	SD
Social Implications of Science						
BalloonSat	95	39.18	5.00	75	39.79	4.85
Non-BalloonSat	88	37.78	5.40	63	38.41	5.49
Normality of Scientists						
BalloonSat	95	36.79	4.67	75	37.79	5.33
Non-BalloonSat	88	35.50	4.36	63	36.05	4.90
Attitude to Scientific Inquiry						
BalloonSat	95	4.54	5.88	75	39.61	6.77
Non-BalloonSat	88	38.03	6.72	63	38.03	7.30
Adoption of Scientific Attitudes						
BalloonSat	95	38.73	4.99	75	37.80	4.43
Non-BalloonSat	88	37.36	6.35	63	36.75	5.26
Enjoyment of Science Lessons						
BalloonSat	95	37.61	7.17	75	37.80	7.15
Non-BalloonSat	88	34.67	8.88	63	33.91	1.14
Leisure Interest in Science						
BalloonSat	95	31.81	8.09	75	32.83	7.09
Non-BalloonSat	88	28.07	8.91	63	27.43	8.85
Career Interest in Science						
BalloonSat	95	35.46	6.98	75	34.80	6.28
Non-BalloonSat	88	31.15	7.53	63	3.52	7.71

**Figure 5: Pre and Post Mean Scores by Attitudinal Category**

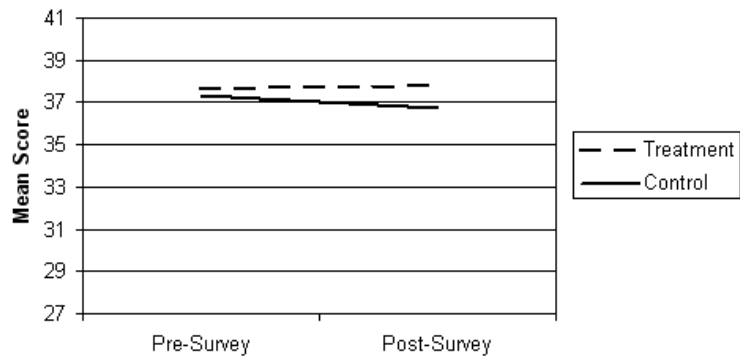




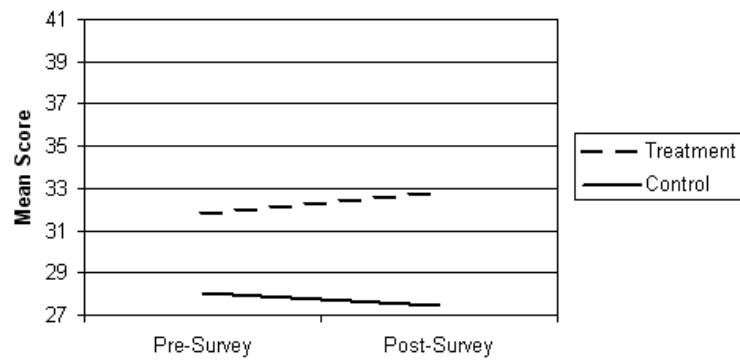
### Attitude to Scientific Inquiry

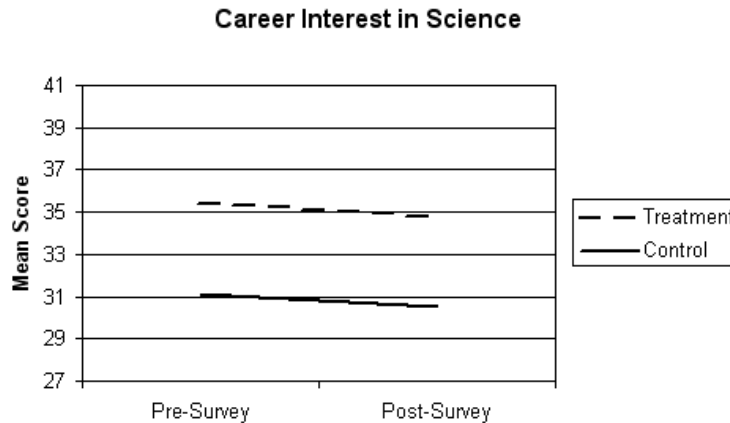


### Enjoyment of Science Lessons



### Leisure Interest in Science





### Results from ANCOVA

**Research Question #1: Do grade seven – ten students develop a more positive attitude toward the social implications of science after building a BalloonSat and analyzing its data than do students who do not participate in the BalloonSat project?**

This research question consists of questions 1, 8, 15, 22, 29, 36, 43, 50, 57, and 64 of the TOSRA. According to the TOSRA handbook, questions 1, 15, 29, 43, and 57 are positive statements and questions 8, 22, 36, 50, and 64 are negative statements and therefore reversed scored. The response percentages for BalloonSat and non-BalloonSat pre and post-survey responses were calculated and the results reported in Appendix I.

The researcher conducted a one-way ANCOVA on the pre and post-survey scores. The independent variable, participation in the BalloonSat project, included two levels: yes (coded as 1) and no (coded as 0). The dependent variable was the scale score of the post-survey questions 1, 8, 15, 22, 29, 36, 43, 50, 57, and 64. The covariate was the scale score of the same questions in the pre-survey. A preliminary analysis evaluating the homogeneity-of-slopes assumption indicated that the relationship between the covariate and the dependent variable did not differ significantly as a function of the independent variable,  $F(1,134) = 1.76$ ,  $MSE = 2.75$ ,  $p = .19$ , partial  $\eta^2 = .01$ . The homogeneity of slopes test therefore indicated that the assumption was met

and that the results of an ANCOVA would be meaningful. The ANCOVA generated results that were not statistically significant,  $F(1,135) = .17$ ,  $MSE = 2.87$ ,  $p = .68$ ,  $\text{partial } \eta^2 = .0$ . Thus, there was no statistical difference between the BalloonSat group and the control group, which did not participate in the BalloonSat project, regarding their attitude toward the social implications of science.

**Research Question #2: Do grade seven – ten students develop a more positive attitude toward the normality of scientists after building a BalloonSat and analyzing its data than do students who do not participate in the BalloonSat project?**

This research question consists of questions 2, 9, 16, 23, 30, 37, 44, 51, 58, and 65 of the TOSRA. According to the TOSRA handbook, questions 9, 23, 37, 51, and 65 are positive statements and questions 2, 16, 30, 44, and 58 are negative statements and therefore reversed scored. The response percentages for BalloonSat and non-BalloonSat pre and post-survey responses were calculated and the results reported in Appendix J.

The researcher conducted a one-way ANCOVA on the pre and post-survey scores. The independent variable, participation in the BalloonSat project, included two levels: yes (coded as 1) and no (coded as 0). The dependent variable was the scale score of the post-survey questions 2, 9, 16, 23, 30, 37, 44, 51, 58, and 65. The covariate was the scale score of the same questions in the pre-survey. A preliminary analysis evaluating the homogeneity-of-slopes assumption indicated that the relationship between the covariate and the dependent variable did not differ significantly as a function of the independent variable,  $F(1,134) = 1.35$ ,  $MSE = 19.00$ ,  $p = .25$ ,  $\text{partial } \eta^2 = .01$ . The homogeneity of slopes test therefore indicated that the assumption was met and that the results of an ANCOVA would be meaningful. The ANCOVA generated results that were not statistically significant,  $F(1,135) = .74$ ,  $MSE = 19.05$ ,  $p = .39$ ,  $\text{partial } \eta^2 = .01$ . Thus,

there was no statistical difference between the BalloonSat group and the control group, which did not participate in the BalloonSat project, regarding the normality of scientists.

**Research Question #3: Do grade seven – ten students develop a greater acceptance of scientific inquiry as a way of thought after building a BalloonSat and analyzing its data than do students who do not participate in the BalloonSat project?**

This research question consists of questions 3, 10, 17, 24, 31, 38, 45, 52, 59, and 66 of the TOSRA. According to the TOSRA handbook, questions 3, 17, 31, 45, and 59 are positive statements and questions 10, 24, 38, 52, and 66 are negative statements and therefore reversed scored. The response percentages for BalloonSat and non-BalloonSat pre and post-survey responses were calculated and the results reported in Appendix K.

The researcher conducted a one-way ANCOVA on the pre and post-survey scores. The independent variable, participation in the BalloonSat project, included two levels: yes (coded as 1) and no (coded as 0). The dependent variable was the scale score of the post-survey questions 3, 10, 17, 24, 31, 38, 45, 52, 59, and 66. The covariate was the scale score of the same questions in the pre-survey. A preliminary analysis evaluating the homogeneity-of-slopes assumption indicated that the relationship between the covariate and the dependent variable did not differ significantly as a function of the independent variable,  $F(1,134) = .34$ ,  $MSE = 33.31$ ,  $p = .56$ , partial  $\eta^2 = .0$ . The homogeneity of slopes test therefore indicated that the assumption was met and that the results of an ANCOVA would be meaningful. The ANCOVA generated results that were not statistically significant,  $F(1,135) = .02$ ,  $MSE = 33.15$ ,  $p = .88$ , partial  $\eta^2 = .0$ . Thus, there was no statistical difference between the BalloonSat group and the control group, which did not participate in the BalloonSat project, regarding the acceptance of scientific inquiry as a way of thought.

**Research Question #4: Do grade seven – ten students develop a greater adoption of scientific attitudes after building a BalloonSat and analyzing its data than do students who do not participate in the BalloonSat project?**

This research question consists of questions 4, 11, 18, 25, 32, 39, 46, 53, 60, and 67 of the TOSRA. According to the TOSRA handbook, questions 4, 18, 32, 46, and 60 are positive statements and questions 11, 25, 39, 53, and 67 are negative statements and therefore reversed scored. The response percentages for BalloonSat and non-BalloonSat pre and post-survey responses were calculated and the results reported in L.

The researcher conducted a one-way ANCOVA on the pre and post-survey scores. The independent variable, participation in the BalloonSat project, included two levels: yes (coded as 1) and no (coded as 0). The dependent variable was the scale score of the post-survey questions 4, 11, 18, 25, 32, 39, 46, 53, 60, and 67. The covariate was the scale score of the same questions in the pre-survey. A preliminary analysis evaluating the homogeneity-of-slopes assumption indicated that the relationship between the covariate and the dependent variable did not differ significantly as a function of the independent variable,  $F(1,134) = 3.11$ ,  $MSE = 18.86$ ,  $p = .08$ , partial  $\eta^2 = .02$ . The homogeneity of slopes test therefore indicated that the assumption was met and that the results of an ANCOVA would be meaningful. The ANCOVA generated results that were not statistically significant,  $F(1,135) = .24$ ,  $MSE = 19.16$ ,  $p = .63$ , partial  $\eta^2 = .0$ . Thus, there was no statistical difference between the BalloonSat group and the control group, which did not participate in the BalloonSat project, regarding the adoption of scientific attitudes.

**Research Question #5: Do grade seven – ten students develop a greater enjoyment of science experiences after building a BalloonSat and analyzing its data than do students who do not participate in the BalloonSat project?**

This research question consists of questions 5, 12, 19, 26, 33, 40, 47, 54, 61, and 68 of the TOSRA. According to the TOSRA handbook, questions 5, 19, 33, 47, and 61 are positive statements and questions 12, 26, 40, 54, and 68 are negative statements and therefore reversed scored. The response percentages for BalloonSat and non-BalloonSat pre and post-survey responses were calculated and the results reported in Appendix M.

The researcher conducted a one-way ANCOVA on the pre and post-survey scores. The independent variable, participation in the BalloonSat project included two levels: yes (coded as 1) and no (coded as 0). The dependent variable was the scale score of the post-survey questions 5, 12, 19, 26, 33, 40, 47, 54, 61, and 68. The covariate was the scale score of the same questions in the pre-survey. A preliminary analysis evaluating the homogeneity-of-slopes assumption indicated that the relationship between the covariate and the dependent variable did not differ significantly as a function of the independent variable,  $F(1,134) = .00$ ,  $MSE = 41.19$ ,  $p = 1.00$ , partial  $\eta^2 = .0$ . The homogeneity of slopes test therefore indicated that the assumption was met and that the results of an ANCOVA would be meaningful. The ANCOVA generated results that were not statistically significant,  $F(1,135) = .49$ ,  $MSE = 4.89$ ,  $p = .49$ , partial  $\eta^2 = .0$ . Thus, there was no statistical difference between the BalloonSat group and the control group, which did not participate in the BalloonSat project, regarding the enjoyment of their science experiences.

**Research Question #6: Do grade seven – ten students develop a greater interest in science and science related activities after building a BalloonSat and analyzing its data than do students who do not participate in the BalloonSat project?**

This research question consists of questions 6, 13, 20, 27, 34, 41, 48, 55, 62, and 69 of the TOSRA. According to the TOSRA handbook, questions 6, 20, 34, 48, and 62 are positive

statements and questions 13, 27, 41, 55, and 69 are negative statements and therefore reversed scored. The response percentages for BalloonSat and non-BalloonSat pre and post-survey responses were calculated and the results reported in Appendix N.

The researcher conducted a one-way ANCOVA on the pre and post-survey scores. The independent variable, participation in the BalloonSat project, included two levels: yes and no. The dependent variable was the scale score of the post-survey questions 6, 13, 20, 27, 34, 41, 48, 55, 62, and 69. The covariate was the scale score of the same questions in the pre-survey. A preliminary analysis evaluating the homogeneity-of-slopes assumption indicated that the relationship between the covariate and the dependent variable did not differ significantly as a function of the independent variable,  $F(1,134) = .34$ ,  $MSE = 34.48$ ,  $p = .56$ ,  $\text{partial } \eta^2 = .0$ . The homogeneity of slopes test therefore indicated that the assumption was met and that the results of an ANCOVA would be meaningful. The ANCOVA generated results that were significant,  $F(1,135) = 3.91$ ,  $MSE = 34.31$ ,  $p = .05$ ,  $\text{partial } \eta^2 = .03$ . Thus, the BalloonSat students reported a statistically significantly larger change in mean score than the control group, which did not participate in the BalloonSat project. This reflects the BalloonSat group's larger increase in interest in science and science related leisure activities.

**Research Question #7: Do grade seven – ten students develop a greater interest in pursuing a career in science after building a BalloonSat and analyzing its data than do students who do not participate in the BalloonSat project?**

This research question consists of questions 7, 14, 21, 28, 35, 42, 49, 56, 63, and 70. In accordance to the TOSRA handbook, questions 14, 28, 42, 56, and 70 are positive statements and questions 7, 21, 35, 49, and 63 are negative statements and therefore reversed scored. The response percentages for BalloonSat and non-BalloonSat pre and post-survey responses were calculated and the results reported in Appendix O.

The researcher conducted a one-way ANCOVA on the pre and post-survey scores. The independent variable, participation in the BalloonSat project, included two levels: yes and no. The dependent variable was the scale score of the post-survey questions 7, 14, 21, 28, 35, 42, 49, 56, 63, and 7. The covariate was the scale score of the same questions in the pre-survey. A preliminary analysis evaluating the homogeneity-of-slopes assumption indicated that the relationship between the covariate and the dependent variable did not differ significantly as a function of the independent variable,  $F(1,134) = .03$ ,  $MSE = 26.81$ ,  $p = .86$ ,  $\text{partial } \eta^2 = .0$ . The homogeneity of slopes test therefore indicated that the assumption was met and that the results of an ANCOVA would be meaningful. The ANCOVA generated results that were not statistically significant,  $F(1,135) = .73$ ,  $MSE = 26.61$ ,  $p = .40$ ,  $\text{partial } \eta^2 = .01$ . Thus, there was no statistical difference between the BalloonSat group and the control group, which did not participate in the BalloonSat project, regarding pursuing a career in science.

### **Analysis of Secondary Research Questions**

This question investigated how gender modified the BalloonSat project's effect on attitude toward science. The research performed a second ANCOVA of the pre and post-surveys to measure the interaction between gender and BalloonSat membership. An interaction affect with a significance of .05 or less is evidence for an interaction.

#### **Secondary Research Question**

**Is there a difference in attitude toward science between male and female students who participated in the BalloonSat project?**



This question investigated possible gender differences in the BalloonSat project. The researcher performed an ANCOVA designed to measure an interaction between gender and BalloonSat membership. None of the seven categories of attitude toward science had a significant interaction between gender and BalloonSat membership. The researcher therefore concludes that there is no gender difference in the BalloonSat project's ability to change student attitudes toward science in the remaining TOSRA categories. Appendix P contains details of these results.

### **Summary of Results**

Table 14 briefly summarizes the results of the seven primary research questions and the subsidiary research question. Statistical analysis identified found significance in one of the seven primary questions but not in the subsidiary question. Chapter V includes detailed discussion of these results.

**Table 14: Summary of Research Findings Primary and Secondary Questions**

Question Number and Description (P = Primary/S = Secondary)	F Value
<b>P1:</b> Do grades seven – ten students develop a more positive attitude toward the social implications of science after building a BalloonSat and analyzing its data (TOSRA S scale)?	.17
<b>P2:</b> Do grades seven – ten students develop a more positive attitude toward the normality of scientists after building a BalloonSat and analyzing its data (TOSRA N scale)?	.74
<b>P3:</b> Do grades seven – ten students develop a greater acceptance of scientific inquiry as a way of thought after building a BalloonSat and analyzing its data (TOSRA I scale)?	.02
<b>P4:</b> Do grades seven – ten students develop a greater adoption of scientific attitudes after building a BalloonSat and analyzing its data (TOSRA A scale)?	.24
<b>P5:</b> Do grades seven – ten students develop a greater enjoyment of science experiences after building a BalloonSat and analyzing its data (TOSRA E scale)?	.49
<b>P6:</b> Do grades seven – ten students develop a greater interest in science and science-related activities after building a BalloonSat and analyzing its data (TOSRA L scale)?	3.91*
<b>P7:</b> Do grades seven – ten students develop a greater interest in pursuing a career in science after building a BalloonSat and analyzing its data (TOSRA C scale)?	.73
<b>S:</b> Is there a difference in attitude toward science between male and female students after building a BalloonSat and analyzing its data?	Not Significant

\* Significant to the  $p < .05$  level.

This study designed a BalloonSat kit in order to test the ability of a BalloonSat project to change student attitudes toward science. In addition to the kits, the researcher created a set of directions to explain the construction and programming of the BalloonSat kit. Student attitudes

toward science were measured before the beginning of the study and at its completion using Fraser's TOSRA survey. An ANOVA evaluated the changes in group mean scores occurring before and after the study and between the BalloonSat and non-BalloonSat student groups. The results of the ANCOVA indicated that only student attitude toward leisure interest in science was significantly different between the BalloonSat and non-BalloonSat groups. In addition, no gender effects were uncovered, indicating that the BalloonSat project affects attitudes toward science equally for males and females.

## **Chapter V**

### **Discussion**

The justification for this study of BalloonSats and student attitude originated with a previous similar study of robotics. That study showed that building a robot positively affected student attitude toward science in four categories, attitude toward the social implications of science, normality of scientists, attitude toward scientific inquiry, and adoption of scientific attitudes. The researcher therefore anticipated that because a BalloonSat project is similar in many ways to building a robot, a BalloonSat project might produce a similar positive affect. The researcher also hypothesized that gender could be a factor influencing the effect of the BalloonSat project.

This is the second study of the effect of BalloonSats and the first to use TOSRA, which measures Klopfer's (1971) seven attitudes toward science. Because previous studies investigated university students and did not use TOSRA, one cannot compare these results directly to other studies. This study's comparison of mean student attitudes before and after the BalloonSat project, however, might expand understanding of the impact of BalloonSat projects on student outcomes and perhaps also extend understanding of the potential impact of project-based learning as a whole.

The following discussion is a summary and interpretation of this study's findings, with respect to the seven attitudinal scales listed below.

1. Social Implication of Science
2. Normality of Scientists
3. Attitude of Scientific Inquiry
4. Adoption of Scientific Attitudes
5. Enjoyment of Science Lessons
6. Leisure Interest in Science
7. Career Interest in Science

Quantitative methods provided the initial analysis of this study's findings. Therefore, in this chapter, discussion of the quantitative results appear first. However, a quantitative analysis does not present the lived experience of the students participating in the BalloonSat project. Therefore, the researcher incorporated the appropriate qualitative findings of each research question into the discussion of each quantitative finding. The result is a clarification and perhaps deeper understanding of each finding.

**Primary Research Question # 1: Social Implications of Science**  
**Do grades seven – ten students develop a more positive attitude toward the social implication of science after building a BalloonSat and analyzing its data?**

Question one measured student attitude toward the value of science and its social implication (S scale). TOSRA statements in this category relate to the time and money spent on research and opinions about the benefits of that research. According to Fraser (1981), this scale measures how strongly a student favors the results of science. A student with a high social implication of science score is more likely than other students to believe that science does more good than harm (Fraser, 1978).

This study found that students in the BalloonSat group displayed no statistically significant change in its mean score ( $p = .68$ ) regarding the social implication of science.

**Table 15: Comparison of Means for Primary Research Question # 1  
TOSRA S Scale: Social Implications of Science**

<b>Student Group</b>	<b>Pre-Survey M</b>	<b>Post-Survey M</b>	<b>Difference</b>
<b>BalloonSat</b>	39.18 (N = 95)	39.79 (N = 75)	+ .61
<b>Non-BalloonSat</b>	37.78 (N = 88)	38.41 (N = 63)	+ .39

The researcher expected an increased favorable attitude toward the social implications of science in this study. While building the BalloonSat, some teams opted to measure environmental factors of the atmosphere. One possible reason student would decide to measure atmospheric temperature is because of their awareness of the public discussion of global warming. Therefore, by building the BalloonSat and measuring the temperature of the atmosphere, these students were able to make a meaningful measurement with an important social implication.

The focus group meetings uncovered examples of the students' beliefs about the positive impact of science. Students' attitudes, however, conditional. When asked about the cost effectiveness of science, student C replied, "I think the cost effectiveness just depends on what type of science you're doing... a type of science that isn't really... useful and you're spending money on it, then it's not... important. But if you're doing something that will... benefit everybody else... then...I think cost effectiveness... is not much of a matter." Student B similarly replied, "I say... there's always a risk to science... just depending on what you're doing." Therefore, it appears that the BalloonSat did not affect the tentative view students held of science's social benefits.

Perhaps one reason why students did not develop a statistically significant increase in attitude toward the social implications of science is that they did not equate their BalloonSat to a scientific tool used by scientists to collect data. Although some students discussed how they enjoyed the BalloonSat project and how they wanted to take additional science classes after building one, no students mentioned how the BalloonSat replicated real science.

**Primary Research Question # 2: Normality of Scientists**  
**Do grade seven – ten students develop a more positive attitude toward the normality of scientists after building a BalloonSat and analyzing its data?**

Question two measured student attitude toward the normality of scientists (N scale). TOSRA statements in this category relate to a student's perception that scientists are normal people as opposed to eccentric. According to Fraser (1981), this is a measure of how strongly a student holds a favorable attitude towards scientists. A student with a high normality of scientists score is more likely than other students to believe that being a scientist does not interfere with a person's ability to have a normal social life (Fraser, 1978).

This study found that students in the BalloonSat group displayed no statistically significant change in its mean score ( $p = .39$ ) in regards to the normality of scientists.

**Table 16: Comparison of Means for Primary Research Question # 2  
TOSRA N Scale: Normality of Scientists**

<b>Student Group</b>	<b>Pre-Survey M</b>	<b>Post-Survey M</b>	<b>Difference</b>
<b>BalloonSat</b>	36.79 (N = 95)	37.79 (N = 75)	+1.00
<b>Non-BalloonSat</b>	35.50 (N = 88)	36.05 (N = 63)	+.55

The researcher expected that completing a BalloonSat would increase student attitude toward the normality of scientists. Designing experiments, sending those experiments into a space-like environment, and analyzing data are actions similar to those that scientists perform. If students realized that they are performing work similar to scientists and having fun at the same time, then it was a reasonable assumption that they would conclude that scientists are normal people like themselves.

The focus group meetings support the conclusion that students see scientists as normal people. When asked what a scientist living next door would look like, student A replied, “Like a normal everyday person.” Student D also agreed with this perception of scientists by responding, “...they’d probably do just the same... like things we do, like... go out to eat... I don’t know, shop... go... swimming or anything. They’re just like us. It’s they just have a different profession.”

Students however, did appear to perceive small differences between scientists and non-scientists. For example, when asked what a scientist would do at home after work, student A replied, “Possibly researching more information or looking at data”. This is not an activity that a typical non-scientist does after coming home from work.



One reason that BalloonSat students did not significantly increase their attitude toward the normality of scientists therefore may be due to not enough students realizing that their work on the BalloonSat mirrors that of scientists. Perhaps they viewed the BalloonSat as too simple a model of a real scientist's work, or simply as school work and not the work of scientists.

**Primary Research Question # 3: Attitude of Scientific Inquiry**  
**Do grades seven – ten students develop a greater acceptance of scientific inquiry as a way of thought after building a BalloonSat and analyzing its data?**

Question three measured student attitude toward the use of inquiry as a method for learning and understanding (I scale). TOSRA statements in this category relate to the student's perception of the vision that they have towards the usefulness and desirability of scientific inquiry. According to Fraser (1981), this scale is a measure of how strongly students accept scientific inquiry as a way of thought. A student with a high acceptance of scientific inquiry score is more likely than other students to want to learn new content through experimentation (Fraser, 1978).

This study found that students in the BalloonSat group displayed no statistically significant change in its mean score ( $p = .88$ ) regarding the acceptance of scientific inquiry.

**Table 17: Comparison of Means for Primary Research Question # 3  
TOSRA I Scale: Attitude of Scientific Inquiry**

<b>Student Group</b>	<b>Pre-Survey M</b>	<b>Post-Survey M</b>	<b>Difference</b>
<b>BalloonSat</b>	4.54 (N = 95)	39.61 (N = 75)	-.93
<b>Non-BalloonSat</b>	38.03 (N = 88)	38.03 (N = 63)	.00

The researcher expected that completing a BalloonSat would increase student attitude toward scientific inquiry. One reason is that the design of the BalloonSat project required the use of scientific inquiry. Before building the BalloonSat, students had to select a research topic and then design the BalloonSat around that topic. Although the researcher provided students with a set of instructions for soldering and programming the flight computer, they still had to assemble the BalloonSat to measure and record two environmental conditions chosen by the group. In addition, the BalloonSat project was not a confirmatory laboratory exercise. Students were unaware of the results they should expect from each experiment. Consequently, it is reasonable to believe that the inquiry approach and open-ended design of the BalloonSat project would permit students to experience scientific inquiry as an enjoyable activity.

One reason that attitude toward scientific inquiry did not significantly increase may be due to the difficulty of the BalloonSat project. In the focus group meeting at HTCS, the researcher asked if students felt that they knew how to assemble the BalloonSat. Student E replied, “No. Because I think like we didn’t know all the technology stuff, or how to program boards. So, if you tried to do that we would have like probably like messed the whole project up.

And we didn't know like... exactly what we were doing... we could have figured some stuff out, but we needed some guidance.”

**Primary Research Question # 4: Adoption of Scientific Attitudes**  
**Do grades seven – ten students develop a greater adoption of scientific attitudes after building a BalloonSat and analyzing its data?**

Question four measured student attitude toward the adoption of scientific attitudes (A scale). TOSRA statements in this category relate to scientific thinking. Examples include evaluating evidence and maintaining an open mind. According to Fraser (1981), this scale is a measure of how strongly students value the attitudes that scientists find important in their research. A student with a high adoption of scientific attitude score is more likely than other students to believe that examining evidence, waiting to draw conclusions, and being willing to change opinions based on evidence are positive traits (Fraser, 1978).

This study found that students in the BalloonSat group displayed no statistically significant change in its mean score ( $p = .63$ ) regarding the adoption of scientific attitudes.

**Table 18: Comparison of Means for Primary Research Question # 4**  
**TOSRA A Scale: Adoption of Scientific Attitudes**

<b>Student Group</b>	<b>Pre-Survey M</b>	<b>Post-Survey M</b>	<b>Difference</b>
<b>BalloonSat</b>	36.75 (N = 95)	37.80 (N = 75)	+1.05
<b>Non-BalloonSat</b>	37.36 (N = 88)	36.75 (N = 63)	-.61

The BalloonSat is a science project and involves a space-like environment, and therefore is similar to building a spacecraft. Consequently, the researcher expected that students who were interested in or motivated by the space program to report that the BalloonSat project encouraged them to think like a scientist involved with the space program. In addition, during the building of the BalloonSat, each student had opportunities to realize that other team members had important contributions and that it was important to consider their ideas. The researcher therefore also expected the teamwork component of a BalloonSat project would encourage students to be open-minded and examine evidence.

During the focus group, students did not mention having or changing their scientific attitudes. However, a discussion of being open-minded appears in both interviews. Neither of the students discussed the importance of being open-minded very strongly. For example, during the HSA interview, the researcher asked if there was ever a time that a fellow classmate convinced you that they had a better way to build the BalloonSat. Student B replied, “There’s (sic) a couple different suggestions on how to wire... how to solder the wire.” However, student B’s reply was tentative. When asked for clarification about having her mind changed by a classmate on the BalloonSat team, she responded, “Well, I think we were both kind of right in a way.”

At the HTCS interview, student E said, “We... when we were doing one of the circuit boards... we... put a piece in... but like... like the way we matched it up was backwards, we need to flip it the other way... and ah... and when, I think it was me in the group was putting it in...and I didn’t realize that I was putting it in backwards... that I didn’t know to which to specific it was suppose to go... and it was suppose to go the other way... someone was tracking it and told me it needs to go the other way... and like checked the packet and everything and... that was right.”.

As can be seen in these two student comments, students did express a benefit to being open-minded. However, students did not always express the importance of being open-minded in strong terms. Further, we should note that both student B and E are females. The male students tended to discuss the importance of being open-minded in terms of other students. One example comes from student I whose response for examples of other students changing their minds contained, “Um... yes, because this... this same person was putting in one piece... and it looked exactly the same... and so... they were ah... we were kind of arguing about it and then we put in the other one, and it was the right one. So... if we had soldered that in... we had to fix.”

**Primary Research Question # 5: Enjoyment of Science Lessons**  
**Do grade seven – ten students develop greater enjoyment in their science lessons after building a BalloonSat and analyzing its data?**

Question five measured the level of enjoyment that students report regarding their science learning experiences (E scale). According to Fraser (1981), this scale is a measurement of how much students enjoy their science learning experiences in both the classroom and laboratory. A student with a high enjoyment of science lessons score is more likely than other students to want to learn about science in class and more likely to be attentive (Fraser, 1978).

This study found that students in the BalloonSat group displayed no statistically significant change in its mean score ( $p = .49$ ) regarding the enjoyment of science lessons.

**Table 19: Comparison of Means for Primary Research Question # 5  
TOSRA E Scale: Enjoyment of Science Lessons**

<b>Student Group</b>	<b>Pre-Survey M</b>	<b>Post-Survey M</b>	<b>Difference</b>
<b>BalloonSat</b>	37.61 (N = 95)	37.80 (N = 55)	+ .19
<b>Non-BalloonSat</b>	34.67 (N = 88)	33.91 (N = 48)	- .75

The researcher expected two factors to influence an increase in mean scores regarding enjoyment of science lessons. First, the BalloonSat experience is a strongly hands-on activity, due to construction and programming involved. Second, students are experiencing learning during a task that emphasizes the play aspect of science.

The focus group meetings supported these two expectations. When asked what science classes students were expecting to take next year, student B replied, “I don’t know exactly what science class I would take, but I would like to take a science class were we build... something like we did and get to see our results. Because... it was fun to actually say we built this ourselves.” Student D replied in a similar fashion, “but now... after I did the BalloonSat... it was really fun and I want to take like more advanced science classes... and like... do like science classes where I can do a lot of projects and build things.”

The fact that students described the BalloonSat as a fun project, but that mean scores for enjoyment of science lessons did not increase significantly possibly might be explained by the following two observations. First, some students in the focus group described the BalloonSat project as a difficult activity. Second, several of the BalloonSats failed to return images. The difficulty constructing the BalloonSat and the failures ultimately experienced in the project may

have proved disappointing to many students. In that case, this science activity might not have been as enjoyable for students as it would have been if it were completely successful.

**Primary Research Question # 6: Leisure Interest in Science**  
**Do grades seven – ten students develop a greater interest in science and science-related activities after building a BalloonSat and analyzing its data?**

Question six measured student attitude toward science as a leisure activity (L scale).

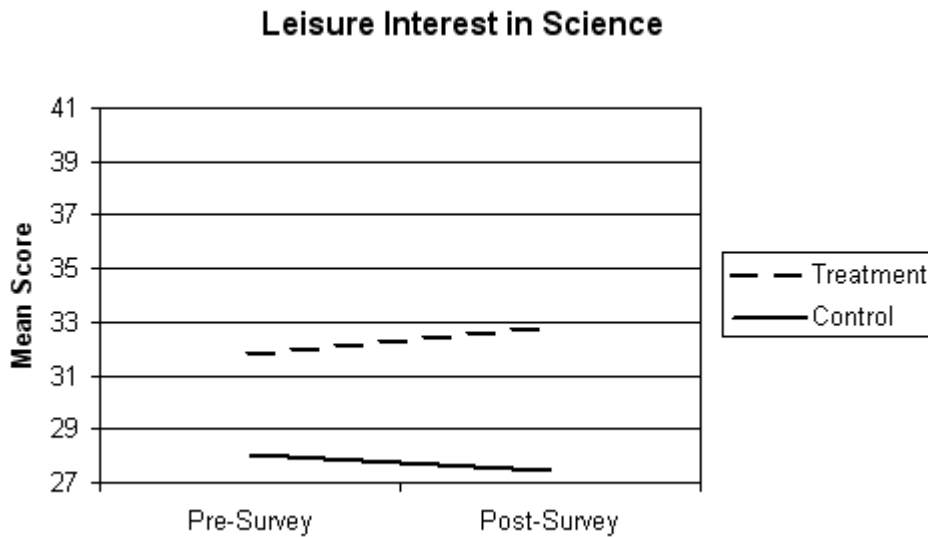
TOSRA statements in this category reflect a student's interest in science as a hobby and the desire to visit museums. A student with a high leisure interest in science is more likely than other students to have a greater interest in science through after school science activities (Fraser, 1978).

This study found that students in the BalloonSat group displayed a statistically significant change in their attitude means ( $p = .05$ ). The strength of the relationship between the BalloonSat independent variable and the attitude dependent variable was small, with a partial  $\eta^2 = .03$ . Thus, membership in the BalloonSat group was responsible for three percent of the measured variance in the dependent variable. A comparison between the L scale means in the mean attitude scores shows a greater increase in the mean attitude score for the treatment group and a smaller decrease for the control group mean.

**Table 20: Comparison of Means for Primary Research Question # 6  
TOSRA L Scale: Leisure Interest in Science**

Student Group	Pre-Survey M	Post-Survey M	Difference
<b>BalloonSat</b>	31.81 (N = 95)	32.83 (N = 75)	+1.02
<b>Non-BalloonSat</b>	28.07 (N = 88)	27.43 (N = 63)	-.64

**Figure 4: Comparison of Means for Primary Research Question # 6**



During the focus group meetings, students expressed a mild leisure interest in science. This study should note, however, that students at both focus group meetings had limited access to science-related after school activities. None of the students at the HSA focus group meeting engaged in leisure activities or hobbies - that made use of science. These students however did express a general desire to visit museums. When asked which museum however, student B replied, “I don’t know of any museum names... but if I was to visit a museum I think I would like to... learn more about dinosaurs.” None of the students at the HTCS focus group meeting described science-related leisure activities either, but did express a desire to take up science-



related hobbies. For example, student D replied this way when asked about his interest in taking up new hobbies, “Um... I think ah I would probably like to start a hobby like... like make... like... adjusting like circuit boards and things.” Since this statement relates more to technology than science, student D may not be distinguishing between science and technology related activities.

**Primary Research Question # 7: Career Interest in Science**  
**Do grades seven – ten students develop a greater interest in pursuing a career in science after building a BalloonSat and analyzing its data?**

Question seven measured student interest in a science career. TOSRA statements in this category are related to future career aspirations. A student with a high career interest in science is more likely than other students to consider taking science and mathematics related classes in high school and college.

This study found that students in the BalloonSat group displayed no statistically significant change in its mean score ( $p = .40$ ) regarding pursuing a career in science.

**Table 21: Comparison of Means for Primary Research Question # 7**  
**TOSRA C Scale: Career Interest in Science**

Student Group	Pre-Survey M	Post-Survey M	Difference
<b>BalloonSat</b>	35.46 (N = 95)	34.80 (N = 75)	-.66
<b>Non-BalloonSat</b>	31.15 (N = 88)	3.52 (N = 63)	-.63

The researcher expected students to believe that the BalloonSat activity represents an example of a scientist's work. Therefore, if students enjoyed the activity, it would increase their interest in a science career. However, during the focus group meeting, some students explained that they had already decided on a science career prior to the study. For example, when asked about future career plans, student B expressed a desire for a nursing and radiology career. Since she had already made these plans, it is not possible for the BalloonSat program to increase her interest in a science career.

Most students did not discuss future career plans. However, many did discuss future educational plans. Since a career in science requires an education in science, focus group comments about future science education plans may represent future career plans. When asked to describe the science classes he plans to attend, student A replied, "I'm not planning to take any of them." Student E on the other hand stated, "Before like... the BalloonSat project I didn't really like... want go far into science... so like I was in college or... going beyond that or anything, I just wanted to ah... like... take other classes, I guess just take it... the minimum and skip it... but like... since we, like this year... I want to like... take science like all through my years of going to school...and be like in a science field... or be like a doctor or like... a vet of something."

### **Secondary Research Question**

This question investigated the possible differences that gender created the BalloonSat project's effect on attitude toward science. There were 138 student records available for this evaluation. A second series of ANCOVA tests measured the interaction between gender and BalloonSat membership. These ANCOVA tests found no statistically significant interaction between BalloonSat membership and gender in any of the seven categories of attitude toward

science. Therefore, the researcher concluded that the BalloonSat project equally affected male and female attitudes toward science.

The focus group interview did however uncover one gender difference in student responsibilities or approaches to completing the BalloonSat. Male students reported that they were the ones to solder the flight computer during the HSA focus group meeting. For example, student A said, “I was going to say that was the only difference... is that the females never touched the... soldering tools...” This did not apply to all the BalloonSat projects. The HTCS team consisted of separate female team and a male team making a BalloonSat. At the focus group meeting, student D (male) reported about the female team, “Uh... I think the... we kind of did more of the work and the just kind of copied off of us. Like they’d come over and ask us what that was and then they’d put it in. So they’d... we’d do it and they... like... copied it... I guess.”

### **Limitations**

This study reported one significant finding in student leisure interest in science. However, this study was limited to nine schools in three states. Perhaps, future BalloonSat studies that can address the following issues and sources of variance will generate findings with greater significance than this study.

1. The different level of each student’s participation on the BalloonSat
2. Student background
3. Teacher background
4. Increasing the sample size -- number of students involved

Because teachers did not build a complete curriculum around the BalloonSat, students largely were free to engage in the BalloonSat project to the degree that they wished. Building a BalloonSat consists of many activities, like soldering, programming, gluing, and testing. Each of

these activities also consists of many unique actions. With so many activities and at least four students per BalloonSat, it was not possible for each student to fully participate in every activity associated with the BalloonSat. In addition, during the focus group meeting, students reported that some of their teammates decided not to fully participate. Therefore, making BalloonSat teams smaller, designing the BalloonSat project for one school year rather than one semester, and helping teachers infuse the BalloonSat project into their curriculum could reduce the variances observed in this study.

It is reasonable to assume that students approached the BalloonSat project with a variety of backgrounds. In fact, the focus group study hints at this. For example, one student explained that he had more experience soldering than his classmates. In another case, one student reported feeling more comfortable programming the BalloonSat flight computer than his classmates did. As a result, his class gave him the task of programming the flight computer while the other students looked on. Because student involvement varied so greatly across teams, the impact of the project is expected to vary among students. Making better training materials available online prior to the next study should help eliminate this source of variance. The materials should include online videos describing the step-by-step directions for assembling and programming the flight computer.

Some teachers in the study explained to the researcher that they had no experience with electronic circuits, whereas other teachers had experience or were able to receive outside help. A teacher's background influences the amount of support the he or she can provide, as does the amount of outside help available to the students. Therefore, creating online materials for teachers to review prior to the start of the project should be a requirement for the next study. In addition, summer workshops for teachers should be valuable in preparing teachers for the study. The teacher at HTCS expressed such a desire when she mentioned that she wishes that she had been

able to attend a BalloonSat workshop at the 2011 conference of the Kansas Association of Teachers of Science (KATS Camp).

Finally, because of the number of students enrolled in this study, this BalloonSat study can find a moderate effect. If the BalloonSat project only has a small effect, then enrolling more students would be necessary to these effects. According to G\*Power, a total of 787 students are needed to find significance for an ANCOVA with significance level of .05, a power of .80, and small effect size. Alternatively, in a future study, students could spend two semesters in a BalloonSat project. The additional exposure to the project may increase its effectiveness therefore making it easier to find statistically significance.

### **Summary**

This study measured the impact that a BalloonSat project had on student attitude toward science. The study used the TOSRA survey to measure the following seven categories of attitude toward science:

1. Attitude toward the social implications of science
2. Attitude toward the normality of scientists
3. Acceptance of scientific inquiry as a way of thought
4. Adoption of scientific attitudes
5. Enjoyment of science experiences
6. Interest in science-related leisure activities
7. Interest in pursuing a career in science

A subsidiary investigation measured how gender modified the effect that the BalloonSat project had on the seven categories above.

The BalloonSat project evaluated in this study found a statistically significant, but small change in one of the seven TOSRA categories, specifically, Leisure Interest in Science. Gender did not influence the effects of BalloonSats on the attitude toward science. I will discuss some of

the possible reasons the study found significance in only one attitude toward science based on the literature review.

First, as to why additional significant findings were not detected. The high school BalloonSat study recently conducted at Taylor University indicated that the BalloonSat project is not likely to create statistically significant findings the first year that high school students build one. Dr. Takehara explained to the researcher that multiple implementations of a BalloonSat program were required before Taylor University found significant results. Taylor's results indicate that expert students, those with four years of experience building BalloonSats are the most likely to show positive results from the BalloonSat activity (Takehara, Dailey, Gavin, Snyder, Smith, & Krueger, 2012).

None of the students involved in this study reported having built a BalloonSat in the past. The students within this study fit within the Taylor's definition of novice student. Based on Taylor's experience therefore, it is not surprising that there was very little in the way of significant findings in this study (Takehara, D., Dailey, J., Gavin, S., Snyder, S., Smith, B., & Krueger, J., 2012).

Researchers Krynowsky (1988), Oliver and Simpson (1988) and Germann (1988) agree that there is a relationship between achievement and attitude. Their studies also indicate that this is not a one-way relationship. The evidence suggests that increased achievement increases student attitudes and that increased attitude increases student achievement. A review of student reports and the focus group meetings revealed that students did not experience as much success with their BalloonSat project as the researcher expected. While nearly all the BalloonSats recorded data, many did not record images. The researcher expects that the impact of images taken from near space is more profound for students than only recording data like air temperature. Perhaps these students would interpret recording images from near space as a larger measure of success

(achievement) than just raw data. The students enrolled in this study may have experienced a smaller increase in attitude toward science because of their perception that they did not achieve the goal of recording images.

Crawley and Koballa (1994) write that many non-social factors affect student attitude in science. Factors like differences in science classrooms environments and student grade levels can affect student attitudes. Koballa (1988) further writes that social factors like peers and parents also are student attitude moderators. Since many teachers in this study had no experience assembling BalloonSats, they were unable to provide their students with the assistance needed. It would not be surprising therefore if this created a classroom environment that did not support student success. Without a sufficient level of knowledge and comfort with the activity, teachers may have unwittingly created a negative message in regard to the BalloonSat activity. Student peers and parents also were not under the control of this study. So even when a student felt excited by the prospect of building a BalloonSat that would travel into near space, he or she may not have received a positive experience.

Only at TMS did the students have the opportunity to work with a scientist and an engineer. In this case, they were a former astronaut and a current software engineer at Microsoft. Compare this to the FIRST robotics challenge that was used as a model for this study. The FIRST Robotic challenge is designed to be too large of a challenge for students to complete on their own. As a result, the FIRST challenge strongly encourages schools to form partnerships with local scientists and engineers. As a result, most students participating in the FIRST challenge spend up to six weeks working alongside scientists and engineers (Welch, 2007). Because of that exposure, students taking part in the FIRST challenge have greater opportunities to see scientists and engineers as normal people. That exposure to scientists and engineers likely lead to the FIRST challenge finding significance in the normality of scientist category and may explain why the BalloonSat study did not.

Even with the number of factors possibly decreasing the effect of the BalloonSat project on student attitude toward science, this study did find one significant finding. Although it was small, students completing the BalloonSat project statistically were more likely to develop an increased attitude toward the leisure interest in science than were the control students. Why should this be the case? There may be a clue in the focus group meeting. During the focus group meeting, one of the students stated that he wanted to build additional BalloonSats. Some students in this study might have discovered that they could build BalloonSats on their own and that the BalloonSat represents a viable science hobby. As such, it is not surprising that the BalloonSat experience would increase leisure interest in science.

Both BalloonSats and robotics show evidence of being effective at changing student attitude toward science. Based on the results of the Welch (2007) FIRST study and this study, robotics and BalloonSats may complement each other by addressing different attitudes toward science. In addition, both can fulfill the desire to incorporate more project-based learning into the science and engineering classroom.

### **Recommendations for Further Study**

This is the first study of the impact of the BalloonSat project on the attitude toward science of students in grades 7-10. The researcher therefore recommends the BalloonSat project be modified in the following ways prior to future studies.

First, the BalloonSat project should be changed into a full year program. Students and teachers both indicated that they felt that they did not have sufficient time to complete the project. The literature describes how the BalloonSat project meets many state science educational standards; therefore, a full year BalloonSat project should be possible. However, until research demonstrates the effectiveness of the BalloonSat project in meeting educational standards, a year-



long program will best fit into an after-school activity, like a science club. By permitting students to spend additional time developing and testing their BalloonSat, more of their BalloonSats should be successful. With increased success, the research expects that students will experience a greater increase in attitude toward science.

Second, BalloonSat launches should take place where students can participate. Helping launch their BalloonSat may create a greater impression on students than just receiving their BalloonSat after its recovery. Potentially, increasing a student's involvement with the BalloonSat project may be similar to increasing the dosage of a treatment. If so, participating in the launch of a BalloonSat may increase its effect.

Third, the BalloonSat needs to be more fool-proof. The design of the BalloonSat kit used in this study does produce successful flights; however, too many of the BalloonSats were not completely successful. The researcher's investigation indicates that the modification of the camera was at fault. The camera provided in this study has a power-save feature that shuts it off after a specified time of inactivity. A camera without this power-save feature appears to be better match for the BalloonSat as it is less likely to shut down. In addition, the air temperatures experienced by the BalloonSat are too cold for alkaline cells. The cold air temperature requires that future BalloonSat cameras to use lithium cells. In addition, chemical hand-warmers and lithium cells with greater capacity may be necessary to keep the BalloonSat camera functioning.

Fourth, teachers planning to use BalloonSats in their classroom need greater familiarity with the construction of the BalloonSat than was provided to teachers in this study. Teachers using the BalloonSat project will benefit from training just as they benefit from training with other curriculum products. Increased familiarity permits teachers to provide less confusing instruction to all students and better help to struggling students. Providing clearer instruction and more assistance to students experiencing difficulty can increase student success with their

BalloonSats.

Fifth, research needs to inform curriculum developers about how the BalloonSat project meets the standards described in the Next Generation Science Standards (NGSS). Many states are likely to adopt these standards since they address a desire for additional STEM in the classroom through project-based education. After states adopt the NGSS, schools will then begin looking for ways to incorporate more project-based activities into their classrooms. In many cases, schools will look to curriculum developers to create the lesson plans and instructional modules that they need. The BalloonSat project is one activity that developers may want to incorporate since it has science and engineering aspects, which are strongly coupled together.

Sixth, if future studies indicate that the BalloonSat project is effective at increasing student attitudes toward science, then studies should begin investigating the effects of each element of the BalloonSat project. The elements of a BalloonSat project should include at a minimum soldering, programming, airframe construction, observing launch, participating at launch, going on chase, being present at recovery of the BalloonSat, and analysis of the data. Curriculum developers can remove or modify those elements found to correlate poorly with improved attitude. Ultimately, a BalloonSat project that achieves statistically significant effects and reasonably large effect sizes should result. In addition, it will contribute to building a theoretical model of relationship between elements making up a BalloonSat project and their correlations between each other and the project's effectiveness.

Seventh, short term increases in attitude in science are not sufficient to claim the BalloonSat project is effective. Therefore, future studies should measure student attitudes toward science for several years after the BalloonSat project. Long term changes in attitude have the mostly likely opportunity to impact a student's plans regarding their science education and career aspirations.

Eighth, one recent study found that multiple BalloonSat exposures are more effective in changing student abilities than a single exposure (Takehara, Dailey, Gavin, Snyder, Smith, & Krueger). This study's focus group however, found that not all students responded equally to the BalloonSat project. In addition to BalloonSats, FIRST, a project-based robotics activity is effective in increasing student attitude toward science (Welch, 2007). The researcher, therefore, recommends incorporating BalloonSats, robotics, and other project-based activities such as bridge building, into multiple year project-based curriculum in order to capture the interest of students and to improve the impact of science literacy of students.

Ninth, studies should investigate the benefits of a well-designed BalloonSat project on its ability to increase academic achievement. The researcher recommends using the NGSS as the guidelines for measuring this achievement.

Finally, research on the BalloonSat project should expand the number of students enrolled. By increasing the number of subjects included, the detection of smaller effects becomes possible. This study indicated that this BalloonSat project had only one moderate effect on student attitude toward science. Other effects might become apparent when smaller effect sizes are statistically significant due to larger sample sizes.

## REFERENCES

- America Competes Act of 2007, Public Law 110-69 Retrieved from  
[http://frwebgate.access.gpo.gov/cgi-bin/getdoc.cgi?dbname=110\\_cong\\_public\\_laws&docid=f:publ069.110.pdf](http://frwebgate.access.gpo.gov/cgi-bin/getdoc.cgi?dbname=110_cong_public_laws&docid=f:publ069.110.pdf).
- American Competitiveness in the Twenty-first Century Act of 2000, S. 2045--106<sup>th</sup>  
Congress: (2000). Retrieved from  
<http://www.govtrack.us/congress/bill.xpd?bill=s106-2045>
- Ausubel, P. (1960). The use of advanced organizers in the learning and retention of meaningful verbal material. *Journal of Educational Psychology*, 51(5), 267-272. doi: 10.1037/h0046669.
- Banchi, H. & Bell, R. (2008). The many levels of inquiry. *Science and children*, 46(2), 26-29.
- Barak, M. & Zadok, Y. (2009). Robotics projects and learning concepts in science, technology and problem solving. *International Journal of Technology and Design Education*. 19, 289-307. doi: 10.1007/s10798-007-9043-3.
- Barker, B. & Ansorge, J. (2007). Robotics as means to increase achievement scores in an informal learning environment. *Journal of Research on Technology Education*, 39(3), 229-243.
- Basken, P. (2009). Scientists and engineers are plentiful; the problem lies with their jobs. *The Chronicle of higher education*, 56(11), 12.

BHALF, *About the Competition*, 2011 NASA (2012). BalloonSat High Altitude Flight, <http://www.grc.nasa.gov/WWW/balloonsat/>.

Bloom, B. 1971. Evaluation of learning in science. In Handbook on summative and formative evaluation of student learning, ed. B.S. Bloom, J.T. Hastings, and G.F. Madaus, 271–273. New York: McGraw-Hill.

Bracey, G. (2008). It's the same old song. *The Phi Delta Kappan*, 89(6), 462-464.

Caldwell, R. & Jones, E. (2011). Using robotics to achieve meaningfully engaged learning. *Services & Semantic Technologies*, AISC 101, 183-188.

Cannon, R. & Simpson, R. (1985). Relationships among attitude, motivation, and achievement of ability grouped seventh-grade life science students. *Science Education*, 69(2), 121-138.

Chambers, J,M & Carbonaro, M. (2003). Designing, developing, and implementing a course on Lego robotics for technology teacher education. *Journal of Technology and Teacher Education*, 11(2), 209-241.

Chrenka, L. (2001). Misconstructing constructivism. *The Phi Delta Kappan*, 82(9), 694-695.

Cobb, C. (2004). Robots recruit tomorrow's engineers. *The Technology Teacher*, 64, 19-21.

Cooper, R. (2007). An investigation into constructivism within an outcomes based curriculum. *Issues in Educational Research*, 17(1). 15-37.

- Corley, E. L. (1997, October). *A constructivist interpretation of attitude towards science*. Paper presented at the annual meeting of the mid-western educational research association. Chicago, IL.
- Corcoran, T. & Silander, M. (2009). Instruction in high schools: the evidence and the challenge. *The Future of Children*, 19(1), 157-183.
- Crawley, F. & Koballa, T. (1994). Attitude research in science education: contemporary models and methods. *Science Education*, 78(1), 35-55.
- Crescitelli, J. (2010). Constructivism vs. NCLB and MCAS – pedagogy vs. standards. Synthesis paper for EdTech 504.
- Creswell, J. (2007). Five qualitative approaches to inquiry. In Creswell, J. (Eds.) *Qualitative inquiry & research design, second ed.* (pp. 75). Thousand Oaks, CA: Sage Publications.
- Cronbach, L. (1951). Coefficient alpha and the internal structure of tests. *Psychometrika*, (16), 297-334.
- DARPA (2010). *DARPA-RA-10-03 Computer Science – Science, Technology, Engineering, and Mathematics (CS-STEM) Education Research Announcement (RA)*, Retrieved from [https://www.fbo.gov/index?s=opportunity&mode=form&tab=core&id=88b3ebc24fb6377fac6b1107d8d96b84&\\_cview=0](https://www.fbo.gov/index?s=opportunity&mode=form&tab=core&id=88b3ebc24fb6377fac6b1107d8d96b84&_cview=0).
- Dillon, R. (1995). Using a robotics contest. *The Technology Teacher*, 55(1), 11-14,23.

Drummond, K. (2010, January). Darpa (sic): U.S. geek shortage is national security risk.

*Wired*, Retrieved from <http://www.wired.com/dangerroom/2010/01/darpa-us-geek-shortage-is-a-national-security-risk/>

Dunleavy, J. & Milton, P. (2008). Student engagement for effective teaching and deep learning. *Education Canada*, 48(5), 4-8.

Easton, P. (2007). Input Output column, Flying high. *Mechanical Engineering*. November 2007, 72.

Faul, F., Erdfelder, E., Lang, A.-G. & Buchner, A. (2007). G\*Power 3: A flexible statistical power analysis program for the social, behavioral, and biomedical sciences. *Behavior Research Methods*, 39, 175-191.

Ellison, B., Giammanco, J., Guzik, G., Johnson, K., Wefel, J. (2006). The Louisiana ACES student-built balloonsat program. *Advances in Space Research*, 38, 2253–2258.

Fenton, A. Weft QDA user's manual. (2006).

FIRST. (2011). Events. Retrieved April 29, 2012, from <http://www.usfirst.org/roboticsprograms/frc/events>.

FIRST. (2011, February). FIRST at a glance. Retrieved April 29, 2012, from <http://www.usfirst.org/aboutus/first-at-a-glance>.

Fraser, B.J. (1978). Development of a test of science-related attitudes. *Science Education*, 62, 509-515.

- Fraser, B.J. (1981). Test of science-related attitudes (TOSRA) handbook. Melbourne: Australian Council for Educational Research.
- Gardner, H. (1973). *The quest for the mind* (pp. 61-65). New York: Alfred A. Knopf.
- Geier, R., Blumenfeld, P., Marx, R., Krajcik, J., Fishman, B., Soloway, E. & Clay-Chambers, J. (2008). Standardized test outcomes for students engaged in inquiry-based science curricula in the context of urban reform. *Journal of Research in Science Teaching*, 45(8), 922-939.
- Germann, P. (1988). Development of the attitude toward science in school assessment and its use to investigate the relationship between science achievement and attitude toward science in school. *Journal of research in science teaching*, 25(8), 689-703.
- Haury, D. L. (1993). Teaching Science Through Inquiry. ERIC CSMEE Digest (March Ed 359 048).
- Hira, R. (2010). US policy and the STEM workforce. *American Behavioral Scientist*, 53(7), 949-961.
- Johnson, R. & Londt, S. (2010). Robotics competitions the choice is up to you!. *Techdirections*, 69(6), 16-20.
- Joint Economic Committee, (December 1999). *The U.S. economy at the beginning and end of the 20th century*, Office of the Chairman, US Department of State, Retrieved from <http://infousa.state.gov/economy/overview/docs/century.pdf>.



- Jones, J., Seiger, B., & Flynn, A. (1999). *Introduction. Mobile robots inspiration to implementation* (2<sup>nd</sup> ed.) (pp.1-2). Natick, MA: A K Peters.
- Kansaku, C., Kehr, L., & Lanier, C. (2007). *STEM-related K-12 outreach through high-altitude balloon program collaborations*, Paper presented at the American Society for Engineering Education, Louisville, KY.
- Karp, T., Gale, R., Lowe, L., Medina, V., & Beutlich, E. (2010). Generation NXT: building young engineers with LEGOs. *IEEE Transactions on Education*, (53)1, 80-87.
- Kerr, W., Lincoln, W. (2010). The Supply Side of Innovation: H-1B Visa Reforms and US Ethnic Invention. NBER Working Paper No. 15768, February 2010. JEL No. F15,F22,J44,J61,O31.
- Kennon, T., Roberts, E., & Fuller, T. (2008). Students at the edge of space. *The science teacher*, 75(1), 37-43.
- Klopfer, L.E. (1971). Evaluation of learning in science. In B.S. Bloom, J.T. Hastings, and G.F. Madaus (Eds), *Handbook on summative and formative evaluation of student learning*. New York: McGraw-Hill.
- Koballa, T. & Crawley, F. (1985). The influence of attitude on science teaching and learning. *School Science and Mathematics*, 85(3), 222-232.
- Koballa, T. (1988). Attitude and related concepts in science education. *Science Education*, 72(2), 115-126.

- Koehler, C. (2003). *BalloonSat: missions to the edge of space*. Paper presented at the 6<sup>th</sup> Annual/USU Conference on Small Satellites, Logan, UT
- Krynowsky, B. (1988). Problems in assessing student attitude in science education: a partial solution. *Science education*, 72(4), 575-584.
- LaCombe, J.C., Wang, E.L., Nicolescu, M., Rivera, P., & Poe, B. (2007). *Design experiences with a student satellite program*. Proceedings of the 2007 American Society for Engineering Education Pacific Southwest Annual Conference.
- Learning Theories Knowledgebase (2011, October). Discovery Learning (Bruner) at Learning-Theories.com. Retrieved October 15<sup>th</sup>, 2011 from [http:// www.learning-theories.com/discovery-learning-bruner.html](http://www.learning-theories.com/discovery-learning-bruner.html).
- Lichtenstein, M., Owen, S., Blalock, C., Liu, Y., Ramirez, K., Pruski, L., Marshall, C., Toepperwein (2008). Psychometric reevaluation of the scientific attitude inventory-revised (SAI-II). *The Journal of Research in Science Teaching*, 45(5), 600–616.
- Lindsay, A. (2005). What's a microcontroller, version 2.2. Parallax. Menlo, CA.
- Lo, C. (2010). Student learning and student satisfaction in an interactive classroom. *The Journal of General Education*, 59(4), 238-263.
- Lou, S., Liu, Y., Shih, R., & Tseng, K. (2011). The senior high school students' learning behavioral model of STEM in PBL. *International Journal of Technology and Design Education*, 21, 161-183. doi: 10.1007/s10798-010-9112-x.

- Lui, C. & Matthews, R. (2005). Vygotsky's philosophy: constructivism and its criticisms examined. *International Education Journal*, 6(3). 386-399.
- Marsh, H., Hau, K. & Kong, C. (2002). Multilevel causal ordering of academic self-concept and achievement: influence of language of instruction (English compared with Chinese) for Hong Kong students. *American Education Research Journal*. 39(3). 727-763.
- Marshall, J. & Horton, R. (2011). The relationship of teacher-facilitated, inquiry-based instruction to student higher-order thinking. *School Science and Mathematics*, 111(3), 93-101.
- Matthews, M. (1993). Constructivism and science education: some epistemological problems. *Journal of Science Education and Technology*, 2(1), 359-370.
- Melchior, A., Cohen, F., Cutter, T., & Leavitt, T. (2005, April). *More than robots: an evaluation of the FIRST robotics competition participant and institutional impacts*. Waltham, MS: Brandeis University Center for Youth and Communities.
- Micron Technology (2010). A Million Dollar Boost for Science, Technology, Engineering and Math Education [press release]. Retrieved from <http://news.micron.com/releasedetail.cfm?ReleaseID=490391>.
- Mishra, P. & Girod, M. (2006). Designing learning through learning to design. *The High School Journal*, 90(1), 44-51.
- Minner, D. D., Levy, A. J., & Century, J. (2010). Inquiry-based science instruction – what is it and does it matter? Results from a research synthesis years 1984 – 2002. *Journal of Research in Science Teaching*, 47(4), 474-496.

- Moore, R., Sutman, F. (1970). The Development, Field Test and Validation of an Inventory of Scientific Attitudes. *Journal of Research in Science Teaching*, 7(2), 85-94.
- Moore, R., Foy, R. (1997). The scientific attitude inventory: a revision (SAI II). *The Journal of Research in Science Teaching*, 34(4), 327-336.
- Munby, H. (1997). Issues of validity in science attitude measurement, *The Journal of Research in Science Teaching*, 34(4), 337–341.
- National Academy of Sciences, National Academy of Engineering, and Institute of Medicine. (2007). *Rising above the gathering storm: Energizing and employing America for a brighter economic future*. Washington, DC: The National Academies Press.
- National Research Council. (1996). *The national science education standards*. Washington, DC: National Academy Press.
- National Research Council. (2000). *Inquiry and the national science education standards: A guide for teaching and learning*. Washington, DC: National Academy Press.
- National Research Council. (2011). *A framework for K-12 science education: practices, crosscutting concepts, and core ideas*. Washington, DC: The National Academies Press.
- National Research Council. (2012). *Standards for engineering, technology, and the applications of science*. Washington, DC: The National Academies Press.

- National Science and Technology Council. (2000), *Ensuring a strong U.S. scientific, technical, and engineering workforce in the 21st century*. Washington DC.
- National Science Board. (2006). *Science and Engineering Indicators–2006*, chapter 3. NSB-06-1. Arlington, VA: National Science Foundation.
- National Science Board (2008). *Science and Engineering Indicators 2008*. Two Volumes (volume 1, NSB 08-01; volume 2, NSB 08-01A). Arlington, VA: National Science Foundation.
- National Science Board. (2012). *Science and Engineering Indicators 2012*, chapter 6. NSB-12-01. Arlington, VA: National Science Foundation.
- Neufeld, D. (2011). *H-1B visas: designing a program to meet the needs of the U.S. economy and U.S Workers*. Testimony given to the house committee on the judiciary subcommittee on immigration policy and enforcement, March 31, 2011.
- Nugent, G., Barker, B., Grandgenett, N., & Adamchuk, V. (2010). Impact of robotics and geospatial technology interventions on youth STEM learning and attitudes. *Journal of Research on Technology in Education*, 42(4), 391-408.
- Obama, B. The White House (2010). *National Security Strategy*, Washington DC.  
Retrieved from [www.whitehouse.gov/sites/default/.../national\\_security\\_strategy.pdf](http://www.whitehouse.gov/sites/default/.../national_security_strategy.pdf)
- Oliver, S. J. & Simpson, R. D. (1988). Influences of attitude toward science, achievement motivation, and science self concept on achievement in science: a longitudinal study. *Science Education*, 72(2), 143-155.

- Osborne, J. (2003). Attitudes towards science: a review of the literature and its implications. *International Journal of Science Education*, 25(9), 1049–1079.
- Pine, J. & Aschbacher, P. (2006). Students' learning of inquiry in 'inquiry' curricula. *The Phi Delta Kappan*, 88(4), 308-313.
- President's Council of Advisors on Science and Technology, Office of Science and Technology Policy. (2010). *Presidential advisors highlight plan for improvements in K-12 STEM education*. Retrieved from <http://www.whitehouse.gov/sites/default/files/microsites/ostp/pcast-stem-ed-release.pdf>.
- Prince, M. & Felder, R. (2007). The many faces of inductive teaching and learning. *Journal of College Science Teaching*, 36(5), 14-20.
- Rivet, A. E. & Krajcik, J. S. (2008). Contextualizing instruction: Leveraging students' prior knowledge and experiences to foster understanding in middle school science. *Journal of Research in Science Teaching*, 45(1), 79–100.
- Robelen, E. (2011). Obama Emphasizes STEM Education in State of the Union. Retrieved from [http://blogs.edweek.org/edweek/curriculum/2011/01/obama\\_laments\\_quality\\_of\\_us\\_ma.html](http://blogs.edweek.org/edweek/curriculum/2011/01/obama_laments_quality_of_us_ma.html).
- Rogers, M., Cross, D., Gresalfi, M., Trauth-Nare, A., & Buck, G. (2011). First year implementation of a project-based learning approach: the need for addressing teachers' orientations in the era of reform. *International Journal of Science and Mathematics Education*, 27(3), 123–130.

- Sanders, M. (2009) STEM, STEM education, STEMmania, *The Technology Teacher*, 68(4), 20-26.
- Siegel, M. & Ranney, M. (2003). Developing the changes in attitude about the relevance of science (CARS) questionnaire and assessing two high school science classes. *Journal of Research in Science Teaching*, 40(8), 757-775.
- Snyder, S. (2011). New heights high altitude research program assessment. Paper presented at the ASEE Conference. Received via email from Dr. Snyder 1 Sept 2011.
- Springer, L., Stanne, M. E., & Donovan, S. S. (1999). Effects of small-group learning on undergraduates in science, mathematics, engineering, and technology: A meta-analysis. *Review of Educational Research*, 69 (1), 21– 51.
- Takehara, D., Dailey, J., Gavin, S., Snyder, S., Smith, B., & Krueger, J. (2012). High altitude ballooning in high school science classes. 3<sup>rd</sup> Annual Academic High-Altitude Conference, June 27-29, 2012, Nashville, TN.
- Tai, R., Lui, C., Maltese, A., & Fan, X. (2006). Planning early for careers in science. *Science*, 312(?), 1143-1144.
- Tan, C., Harji, M. B., & Lau, S. (2011). Fostering positive attitude in probability learning using graphing calculator. *Computers and Education*, 57(3), 2011-2024.
- Thomas, J. (March 2000). A Review of Project-Based Learning ([www.autodesk.com/foundation](http://www.autodesk.com/foundation) [March, 2000]), 2–3.

- Ucar, S. & Trundle, K. C. (2011). Conducting guided inquiry in science classes using authentic, archived, web-based data. *Computers and Education*, 57(2), 1571-1582.
- Van de gaer, E., Pustjens, H., & De Munter, J. (2009). School engagement and language achievement: a longitudinal study of gender differences across secondary school. *Merrill-Palmer Quarterly*, 55(4), 373-405.
- Verma, A, Dickerson, & McKinney, S. (2011). Engaging students in STEM careers with project-based learning-MarineTech Project. *Technology and Engineering Teacher*, 71(1), 25-31.
- Voss, H., Dailey, J., & Snyder, S. (2010). *High-altitude balloon launches and hands-on sensors for effective student learning in astronomy and STEM*. First CCLI Balloon Conference, June 23, 2010, Power Point presentation.
- Vygotsky, L. S. (1978). *Mind in society: The development of higher psychological processes*. Cole, Michael (Ed); John-Steiner, Vera (Ed); Scribner, Sylvia (Ed); Souberman, Ellen (Ed) Harvard University Press: Oxford, England.
- Weigel, A. (2011). *STEM and key workforce issues*, AIAA, Retrieved March 6, 2011, From [http://www.aiaa.org/documents/public/CVD\\_Stem\\_Workforce\\_Briefing%20\\_Weigel.ppt](http://www.aiaa.org/documents/public/CVD_Stem_Workforce_Briefing%20_Weigel.ppt).
- Weissman, J. & Boning, K. (2003). Five features of effective core courses. *The Journal of General Education*, 52(3), 50-174.



Welch, A. G. (2007). The effects of the FIRST robotics competition on high school students' attitudes towards science (doctoral dissertation). Retrieved from UMI. (3283939)

Williams, K., Kurtek, K., & Sampson, V. (2011). The affective elements of science learning. *The Science Teacher*, 78(1), 40-45.

## APPENDICES

## APPENDIX A

### Test of Science Related Attitudes (TOSRA)

(Fraser, 1981)

#### Directions:

1. This test contains a number of statements about science. You will be asked what you think about these statements. There are no “right” or “wrong” answers. Your opinion is what is wanted.
2. For each statement, draw a circle around the specific numeric value corresponding to how you feel about each statement. **Please circle only ONE value per statement.**

5 = Strongly Agree (SA)

4 = Agree (A)

3 = Uncertain (U)

2 = Disagree (D)

1 = Strongly Disagree (SD)

Statement	SA	A	U	D	SD
1. Money spent on science is well worth spending.	5	4	3	2	1
2. Scientists usually like to go to their laboratories when they have a day off.	5	4	3	2	1
3. I would prefer to find out why something happens by doing an experiment than be being told.	5	4	3	2	1
4. I enjoy reading about things that disagree with my previous ideas.	5	4	3	2	1

<b>Statement</b>	<b>SA</b>	<b>A</b>	<b>U</b>	<b>D</b>	<b>SD</b>
5. Science lessons are fun.	5	4	3	2	1
6. I would like to belong to a science club.	5	4	3	2	1
7. I would dislike being a scientist after I leave school.	5	4	3	2	1
8. Science is man's worst enemy.	5	4	3	2	1
9. Scientists are about as fit and healthy as other people.	5	4	3	2	1
10. Doing experiments is not as good as finding out information from teachers.	5	4	3	2	1
11. I dislike repeating experiments to check that I get the same results.	5	4	3	2	1
12. I dislike science lessons.	5	4	3	2	1
13. I get bored when watching science programs on TV at home.	5	4	3	2	1
14. When I leave school, I would like to work with people who make discoveries in science.	5	4	3	2	1
15. Public money spent on science in the last few years has been used widely.	5	4	3	2	1
16. Scientists do not have enough time to spend with their families.	5	4	3	2	1
17. I would prefer to do experiments rather than to read about them.	5	4	3	2	1

<b>Statement</b>	<b>SA</b>	<b>A</b>	<b>U</b>	<b>D</b>	<b>SD</b>
18. I am curious about the world in which we live.	5	4	3	2	1
19. School should have more science lessons each week.	5	4	3	2	1
20. I would like to be given a science book or a piece of science equipment as a present.	5	4	3	2	1
21. I would dislike a job in a science laboratory after I leave school.	5	4	3	2	1
22. Scientific discoveries are doing more harm than good.	5	4	3	2	1
23. Scientists like sports as much as other people do.	5	4	3	2	1
24. I would rather agree with other people than do an experiment to find out for myself.	5	4	3	2	1
25. Finding out about new things is unimportant.	5	4	3	2	1
26. Science lessons bore me.	5	4	3	2	1
27. I dislike reading books about science during my holidays.	5	4	3	2	1
28. Working in a science laboratory would be an interesting way to earn a living.	5	4	3	2	1
29. The government should spend more money on scientific research.	5	4	3	2	1
30. Scientists are less friendly than other people.	5	4	3	2	1
31. I would prefer to do my own experiments than to find out information from a teacher.	5	4	3	2	1

<b>Statement</b>	<b>SA</b>	<b>A</b>	<b>U</b>	<b>D</b>	<b>SD</b>
32. I like to listen to people whose opinions are different from mine.	5	4	3	2	1
33. Science is one of the most interesting school subjects.	5	4	3	2	1
34. I would like to do science experiments at home.	5	4	3	2	1
35. A career in science would be dull and boring.	5	4	3	2	1
36. Too many laboratories are being built at the expense of the rest of education.	5	4	3	2	1
37. Scientists can have a normal family life.	5	4	3	2	1
38. I would rather find out things by asking an expert than by doing an experiment.	5	4	3	2	1
39. I find it boring to hear about new ideas.	5	4	3	2	1
40. Science lessons are a waste of time.	5	4	3	2	1
41. Talking to my friends about science after school would be boring.	5	4	3	2	1
42. I would like to teach science when I leave school.	5	4	3	2	1
43. Science helps to make life better.	5	4	3	2	1
44. Scientists do not care about their working conditions.	5	4	3	2	1

<b>Statement</b>	<b>SA</b>	<b>A</b>	<b>U</b>	<b>D</b>	<b>SD</b>
45. I would rather solve a problem by doing an experiment than be told the answer.	5	4	3	2	1
46. In science experiments, I like to use new methods which I have not used before.	5	4	3	2	1
47. I really enjoy going to science lessons.	5	4	3	2	1
48. I would enjoy having a job in a science laboratory during my school holidays.	5	4	3	2	1
49. A job as a scientist would be boring.	5	4	3	2	1
50. This country is spending too much money on science.	5	4	3	2	1
51. Scientists are just as interested in art and music as other people are.	5	4	3	2	1
52. It is better to ask a teacher the answer than to find it out by doing experiments.	5	4	3	2	1
53. I am unwilling to change my ideas when evidence shows that the ideas are poor.	5	4	3	2	1
54. The material covered in science lessons is uninteresting.	5	4	3	2	1
55. Listening to talk about science on the radio would be boring.	5	4	3	2	1
56. A job as a scientist would be interesting.	5	4	3	2	1
57. Science can help to make the world a better place in the future.	5	4	3	2	1

<b>Statement</b>	<b>SA</b>	<b>A</b>	<b>U</b>	<b>D</b>	<b>SD</b>
58. Few scientists are happily married.	5	4	3	2	1
59. I would prefer to do an experiment on a topic than to read about it in science magazines.	5	4	3	2	1
60. In science experiments, I report unexpected results as well as expected ones.	5	4	3	2	1
61. I look forward to science lessons.	5	4	3	2	1
62. I would enjoy visiting a science museum on the weekend.	5	4	3	2	1
63. I would dislike becoming a scientist because it needs too much education.	5	4	3	2	1
64. Money used on scientific projects is wasted.	5	4	3	2	1
65. If you met a scientist, he/she would probably look like anyone else you might meet.	5	4	3	2	1
66. It is better to be told scientific facts than to find them out from experiments.	5	4	3	2	1
67. I dislike other peoples' opinions.	5	4	3	2	1
68. I would enjoy school more if there were no science lessons.	5	4	3	2	1
69. I dislike reading newspaper articles about science.	5	4	3	2	1
70. I would like to be a scientist when I leave school.	5	4	3	2	1



## APPENDIX B

### Scale Allocation and Item Scoring

Social Implications Of Science	Normality Of Scientists	Attitude to Scientific Inquiry	Adoption of Scientific Attitudes	Enjoyment Of Science Lessons	Leisure Interest in Science	Career Interest in Science
1 (+)	2 (-)	3 (+)	4 (+)	5 (+)	6 (+)	7 (-)
8 (-)	9 (+)	10 (-)	11 (-)	12 (-)	13 (-)	14 (+)
15 (+)	16 (-)	17 (+)	18 (+)	19 (+)	20 (+)	21 (-)
22 (-)	23 (+)	24 (-)	25 (-)	26 (-)	27 (-)	28 (+)
29 (+)	30 (-)	31 (+)	32 (+)	33 (+)	34 (+)	35 (-)
36 (-)	37 (+)	38 (-)	39 (-)	40 (-)	41 (-)	42 (+)
43 (+)	44 (-)	45 (+)	46 (+)	47 (+)	48 (+)	49 (-)
50 (-)	51 (+)	52 (-)	53 (-)	54 (-)	55 (-)	56 (+)
57 (+)	58 (-)	59 (+)	60 (+)	61 (+)	62 (+)	63 (-)
64 (-)	65 (+)	66 (-)	67 (-)	68 (-)	69 (-)	70 (+)

For positive items (+), responses SA, S, N, D, and SD are scored 5, 4, 3, 2, 1, respectively.

For negative items (-), responses SA, S, N, D, and SD are scored 1, 2, 3, 4, 5, respectively.

Omitted or invalid responses are scored 3. (Fraser, 1981, p. 11)

## APPENDIX C

### Focus Group Meeting Protocol and Questions

#### *Focus Group Questions*

*The names of the students were removed and replaced by a single letter.*

*The researcher will ask the following questions during the focus group meeting.*

9. *Did the BalloonSat project change your impression of the usefulness of science?*
  - a. *Is science answering important questions? What are some examples of important questions?*
  - b. *Is science cost effective for its benefit? Too expensive, just right, good bargain?*
  - c. *What kinds of risks does science present to society? Very few, an acceptable risk, too risky?*
10. *Did the BalloonSat project change your view of what kind of person can be a scientist?*
  - a. *If you live next door to a scientist, what would this person look like?*
  - b. *What kinds of activities would this person do after work?*
  - c. *What kind of family would this person have?*
11. *Did the BalloonSat project change your belief in the usefulness of science in discovering knowledge?*
  - a. *Are there any important questions that science cannot answer, given enough time? Examples?*
  - b. *Are there any questions it is best that science doesn't investigate? Examples?*
  - c. *Are some questions best left as mysteries? Explain?*
12. *Did the BalloonSat project change your opinion regarding the importance of being open-minded and ready to revise your thoughts and plans?*
  - a. *Did you frequently know best how to build the BalloonSat?*

- b. Did anyone on your team convince you that they had a better idea? Examples?*
  - c. Where most of your team pretty clueless about the BalloonSat? Examples?*
- 13. Did the BalloonSat project change how you view your science classes?*
  - a. What science classes are you know planning to take? Why?*
- 14. Did the BalloonSat project change the hobbies and activities you wish to pursue?*
  - a. What are your current hobbies?*
  - b. What hobbies do you want to start now?*
  - c. What science museums have you visited before?*
  - d. Which science museums do you want to visit in the next few years? Why?*
  - e. If there is a science club at school, do you plan to join it? Why?*
  - f. If you have access to science-related after-school programs, so you plan to join them? Why?*
- 15. Did the BalloonSat project change your plans for after graduation?*
  - a. How would you describe how your plans have changed?*
- 16. Did males and females work differently on the BalloonSat project? Examples?*
- 17. Did students of different ages work differently on the BalloonSat project? Examples?*
- 18. Did students with more experience in robotics or science fairs work differently on the BalloonSat project? Examples?*
- 19. Did students living in different communities work differently on the BalloonSat project? Examples?*

## **APPENDIX D**

### **Focus Meeting Transcript**

B and E are female

A, C, D, F, G, H, I are male

#### **Focus Group Meeting**

**May 11, 2012, 1:10 pm**

**HSA**

Paul:

Okay... so you guys did this BalloonSat project... and I've got your studies here. So what... what I'm looking at now is... just how you feel...that your... how... what you feel that how you feel about science changed. And what you think about science. So that's... that's what I'm here for. So you'll need to make sure we talk loud enough... especially since we have a fan going there... so we'll make sure we talk loud enough that I can hear this. Okay, so... you guys can just answer how ever... when ever you want.. how ever you want... just make sure you tell me that you're A, B, or C so that when I put this into my notes... so I can put in the written part, A said this, B said that, C said that. Okay? So here's what I'd like to know... ahhh... did the BalloonSat change your impression of the usefulness of science. And now ...so specifically... I would mean something like this... is science answering important questions? Do you feel science answers important questions? Yes or no... and what are some examples of some important questions that you can think of.

B:

Yeah. I think science answers important questions. Uh

Paul:

So... what kind of examples of important questions can you think of... that... that science answers?

B:

Like what happens to certain things... or how to solve certain things

Paul:

So like solving... problems

B:

Yeah

Paul:

Okay... so okay. Okay do either of you have any input as to as far as... science answering important questions and what kind of important questions can you think of? That science answers.

PAUSE

Paul:

I'm just asking your opinion, its not... it's not that you're being graded on this or anything like that. It's just... how would you answer... what would you think.

C:

Ah... I think that it does answer pretty important questions like... you know... like... different things... like coming up with new things... things we already know... is there different ways that we can expand on things that we already know... umm...

Paul:

Okay... okay you say the word things... do you mean just physical things... do you mean ideas...

C:

Ideas... things... stuff that we already know.

Paul:

Okay. Now is science... is science cost effective. Is it too expensive, just right, or is it a good bargain. So... there is always a cost associated with doing science. And people have to pay taxes to make this happen. So the cost of doing science. Again... I'm not looking at... have you have done any research... and do you know a yes or no specifically, but just is your gut feeling as far as... the cost effectiveness of science. Is it a good bargain... are we spending too much in science... are spending just enough... are we getting out of it for what we spend.

B

I think... that... I don't know exactly how much we spend but what I know, I think we are doing good on that... what we are spending and we are spending it on.

Paul:

Okay.

A:

I agree with B.

Paul:

Okay.

C:

Ah... I think the cost effectiveness just depends on what type of science you're doing like everything... if you're doing... a type of science that isn't really like... useful and you're spending money on it, then it's not... not important. But if you're doing something that will... you know... benefit everybody else... then... then I think cost effectiveness wouldn't... is not much of a matter.

Paul:

Did you have something you wanted to say to that? Or did you agree?

No Response

Paul:

Okay... so what kind of risk does science present to society? Ah... is it kind of risky... are we maybe taking too many chances... more than new should...or there's just no risk what so ever... or is the risk... there's a good balance of risk.

B

I say... there's always a risk to science... just depending on what you're doing.  
Like we could be researching or trying to make something... but make it in a  
different way than the first way we made it... and... if something happens... like  
something blew up or something... in a way it could risk certain things

C:

I don't think it's too risky... I think there is always cost... when you do anything  
there's always going to be... positives and the negatives

Paul:

Okay, so there's... there's always a risk and some benefits. So... are you feeling  
that it's... it's an acceptable risk...

C:

Yes.

Paul:

Okay. Is there anything you wanted to add to that?

No Response

Paul:

Okay, so the second question now... we are going to look specifically at the  
BalloonSats. So the BalloonSat's the project you guys just built and we launched  
on the weather balloon for you. Okay... so now... I want to find out that once



you've done this BalloonSat... what do you think... is the kind of person that could be a scientist. So if you lived next door to a scientist... let's say your next door neighbor was a scientist... what would you think... he would be... he or she would look like?

A:

Like a normal everyday person

Paul:

Normal everyday person? Okay

B:

I think the same thing... an everyday person

C:

I think the same thing... just like... just like a normal everyday person.

Paul:

Okay... now what kind of activities do you think a scientist would do after work?

So we know a scientist works in a lab some place... its five o'clock... he or she has gone home... what kind of activities do you think a scientist would then... once they get home and they are off from work?

A:

Possibly researching more information or looking at data

B:

I think in a way... scientist will live a normal life as everybody else... they have to go home cook dinner. Maybe, I think... they probably... what I umm... do stuff outdoors or try to figure other stuff out... to give them more ideas.

C:

I think maybe they might try to expand their research a little bit when they get home. But other than that... I'm pretty sure it's probably just normal everyday life.

Paul:

What kind of a family... assuming this person has a family... maybe they don't have a family... what kind of a family do you think... that a scientist would have?

A:

Regular 'ol family... wife, children, dog, cat.

B:

I say... a regular family probably... talks to his kids more about science and how to do it... and were they think... he should do it... he or her.

Paul:

Okay

C:

I think just a regular family.

Paul:

Okay. I want to make sure you all have a chance to talk. Okay... ah... now I want to see how the BalloonSat changed your belief... or how it effects your belief in the usefulness of science in discovering knowledge. So here is some questions that I have. Umm... are there some important questions that science cannot answer... even given enough time. So are there important questions that we want to know... that scientists... that science just could not answer... even if we gave... science... a thousand years to answer.

A:

Yes

Paul:

So you think... there's some questions science can't answer

A:

Yes

Paul

Okay

B:

I think...yeah there are some things that they will never answer. I don't anybody can just find answer for everything.

C:

I agree. There's probably things they can't answer.

Paul:

So now, let me... probe a little bit further... and... what's an example of an important question that science may not be able to answer?

A:

What is a black hole?

Paul:

What is a black hole? Okay.

B:

Where does space end?

Paul:

Where does space end? Okay. Like in the universe... the end of the universe kind of space?

B:

Uh-uh.

Paul:

Can you give some examples of ... maybe an important question... that science

may not just be able to answer... even given enough time?

C:

I don't know...

Paul:

But you do think there are some questions but

C:

Yeah

Paul:

... that you just can't think of any off the top of your head that might be important that science can't answer. Okay. Now are there examples of... of some questions that science shouldn't try to answer? That are best left... unanswered?

A:

I don't know of any examples but I do... I just know everything should be answered.

Paul:

Everything should be answered but... okay.

B:

I think everything should be answered even if it's bad... so we at least know.

Paul:

Okay. So looking... again at questions that maybe... they're questions that we

have... that maybe science shouldn't investigate. And if there's an example... a question like that, can you think of an example.

C:

I think all questions should be answered.

Paul:

Ah... let's see... now we look at questions regarding your opinion about being opened-minded s regarding the importance of being opened minded and being... ready to revise... what you think might be... a correct answer or how to approach something. So some specific questions I would ask... did you frequently know best how to build the BalloonSat? So when you were building the BalloonSat... do you think that, yeah I know how to do this... and I'm really the one... and I know to do this... and I should do this... I can get this done... umm, I know what I'm doing... or pretty certain what I'm doing.

The teacher laughs slightly. She is in the back of the classroom listening to the interview.

A:

No, I had no idea what at first... about the balloon satellite.

Paul:

Okay

B:

At first, I didn't know what to do... but I... was sure we was going to be able to

get it put together.

C:

I wasn't really here, but... I don't know.

Paul:

Now when you were working on this... once you saw what was going on with the BalloonSat, did you feel pretty confident that I know how to do this? So this is after you had looked at all the parts and start reading the directions.

C leaves the room

B:

I think we kind of knew what we was doing afterwards, there's just a couple of things... that you put in backwards, but it was in the right place.

A:

Yeah, I though we had a little more of a feeling towards the middle... than the beginning... of what we should do.... How things should be done.

Paul:

Okay. Now while you're building this... your classmates would come up with some different ideas of how to do things. Was there ever a time whenever one of your classmates... convinced you... that you should do... build something differently... do something differently when building the BalloonSat?

A:

No. Nothing that I... I can recall.

B:

There's a couple different... suggestions... on how to wire... how to wire... how to solder the wire.

Paul:

So that... so someone convinced you to do it differently?

B:

I think...

Paul:

Or were you pretty sure about, I got it right and that person has got it wrong.

B:

Well... I think we were both... kind of right in a way.

Paul:

Both right in a way. Okay. Ahh... do you feel... this is not you... this is just the rest of your... your classmates. Do you feel the rest of your classmates were pretty clueless how to build the BalloonSat.



A:

No. Not at all.

Paul:

So did you feel that... your... this is not you, but the rest of your classmates... if they were kind of clueless how to build this BalloonSat?

B:

No, I think... everybody kind of had a clue.

Paul:

Okay

B:

Yeah

Paul:

Okay... umm... so let's see now... let's see how BalloonSats has changed your view of your science classes. What science classes are you planning to take now... and why.

B:

Umm... I'm not planning to take any of them.

Paul:

You said you're not planning to take any of them. Do you have options to take science classes though... next year?

A:

Probably. Possibly my general ed, but... as far as I know

B:

I don't know exactly what science class I would take, but I would like to take a science class were we build... something like we did and get to see our results.

Because we actually... it was fun to actually say we built this ourselves

Paul:

Okay. Let's see now... Let's start looking at things like hobbies and activities that you like to pursue. So what kind of hobbies do you currently do right now?

A:

I work.

Paul:

You work. Okay... so what are you doing after work... for fun?

B:

Umm... relaxing in the house.

Paul:

Just relaxing... so you don't do... sports or science...

A:

Reading a book now and again.

Paul:

Okay.

A:

I read... every blue moon.

Paul:

Every blue moon, okay. Blue moon's like every two and half years

Laughter

A:

Umm... I don't play video games... I watch TV... I watch a little... little...

Paul:

Okay. So B, what kind of... activities are you doing after school, after work?

B:

I...

Paul:

What kinds of hobbies... hobbies would be a good example.

B:

Oh well... I really don't do much... after school.

A:

Like knitting...

B:

No, I play video games... I read once in a while actually when I get off of work.

Umm... I really don't have a lot of free time.

Paul:

Okay so... I'm going to ask now what kind of science museum have you visited in the past. So think back to being really young...

A:

I went to Science City... in fifth grade. Science City

Paul:

Okay, where is Science City?

A:

It's in Kansas City.

Paul:

Kansas City. Science City. Okay I'm going to look that one up because I'm not familiar with it. Uh... what can you tell me about Science City? What's that all about?

A:

Well... umm... they just a whole bunch of stuff that had to do with like weather... gravity...

B:

Dinosaurs

A:

Yeah, dinosaurs...

Paul:

Okay. So can you think of any science museums you've been to in the past?

B:

I've been to Science City. And we just learned about weather... umm...  
dinosaurs... stuff like that.

Paul:

Okay... Ah...so what science museums would you like to visit in the next few  
years? So you've been to one... so thinking maybe five or ten years from now...  
which... can you think of any you would like to visit. Or would you like to visit  
them, period... even if you can't think of one specifically.

A:

Smithsonian.

Paul:

The Smithsonian? Okay... the Smithsonian has a lot of museums... do you have  
an idea of which one?

A:

Nope. The one that has science. I'm not sure... I really don't know which one of them is a science museum.

Paul:

Okay... there's the museum of natural history... of course there's the air and space museum... those will be kind of science.

A:

The air and space... that sounds interesting

Paul:

Okay. Any others... that you can think of... that you might like to visit? Maybe if you can't think of one specifically... would there be a museum of a type that you would like to visit?

A:

Umm... I don't have any specific museums that I would like to visit. But I would like to visit the space and air... that would be something I'd like to do.

Paul:

So any kind of space and air museum...

A:

Oh yeah.

Paul:

Okay. So thinking next five or ten years... what kind of... do you have any museums in particular that you'd like to visit... or do you have museums of a type you would like to visit?

B:

I don't know of any museum names... but if I was to visit a museum I think I would like to... learn more about dinosaurs.

Paul:

Okay... dinosaurs, okay. Okay... umm... is there a science club at this school?

A:

No!

Paul:

No science club. Okay. Umm... if there was one... would you... would you want to join in, or be a part of that science club... if there was a science club.

B:

It... I'd say it depends. I would like to do... if it was like hands on... stuff like that... I think I'd like to. But if it was just reading out of a book... or something... and answering questions... I don't think I would.

Paul:

So hands on is what you're interest in doing.

B:

Yeah

A:

I would agree... more hands on

Paul:

Umm... okay

A:

More physical... more physical activities... in the classroom... or discussions.

Paul:

So if there was one... you would want to join?

A:

Oh yeah

Paul:

Okay... okay. Ah... do you have access to any science related activities after school. This is Topeka, so we probably... limited...

A:

Yeah



Paul:

The 4H club does their... does their SpaceTech... umm... you've got the Discovery Center here, but that's probably more... for younger children. Ah... scouting does some kind of science stuff. So is there... any kind of a... after school science activity... that you might be interested in doing. Or would you just not be interested in doing... a science activity after school.

B:

I would like to... ah... visit the new... children's... museum. They say you can paint on the walls and stuff... I want to go.

Laughs slightly

Paul:

You said you could do... do what now?

B:

Paint on the walls and different stuff.

Paul:

Oh... paint on the walls. Okay

B:

I want to go.

A:

I... I don't think I really would ... be interested... in any after school science.

Paul:

Okay. Now we want to look at what your plans are for after graduation. So... think when you first started this semester... to what you think about now. What would be your change in plans for graduation. So think about what you wanted to do at the beginning of the semester after graduation... after high school... what's your plans now... for after graduation.

B:

I am going to nursing and radiology.

Paul:

Okay... okay did you want to do that at the beginning of the semester?

B:

Yes

Paul:

Okay. So that's not changed... you're still... pretty much focused on... getting into nursing and radiology.

B:

Yeah... I just changed... my ah... I changed it my freshman year. I did want to be... ah... a veterinarian.

Paul:

A veterinarian... okay

B:

Yeah

A:

I plan on going to Kansas City Community College and getting my... associate...  
my associate degree in audio engineering. Which is a science degree.

Paul:

Audio engineering... okay. Audio engineering... okay... was that... was that...  
the beginning of the semester... you wanted to do that also?

A:

Oh yeah.

Paul:

Okay... so that's not changed. Okay. Umm... so now... let's do... since we've got  
male and female here now... would you say the girls worked differently on the  
BalloonSat than the boys did?

A:

Umm... no, not that I could tell. It was equal amount of effort and... time and  
work put in by everybody.

Paul:

Now let me ask the young lady in our group here... do you feel that the boys worked differently on the BalloonSat than the girls did?

B:

I think everybody did the same... the only difference was... um... us girls didn't solder.

Paul:

Did not solder.

B:

Yeah... we left that to the boys.

Paul:

Did you have something to add to that?

A:

I was going to say that was the only difference... is that the females never touched the... soldering tools or

Paul:

Okay

A:

They we more into putting the wires into the holes

Paul:

Okay...ah... are you all basically the same age?

A:

I'm 18

B:

I'll be 18 in four months

Paul:

Okay. So the question I wanted to ask is if... being a different age made a difference in the way they worked on the BalloonSat. But it sounds like there really much of a difference in their ages. Ah, let's see.... Have any of your ever done... some robotics... or you done... ah... science fairs in the past?

A:

No. I never did.

Paul:

You never did any of those. Okay.

B:

I think we had a science fair in my elementary school.

Paul:

Okay... do you think that... make you work on the BalloonSat a little bit differently than ... than someone who did not... do... get involved with a science

fair?

**B:**

I have no clue. It's been so long, but...

**Paul:**

Okay...so... that pretty much answers my questions... because my next question was on different communities... and we are all in the same town, Topeka. I guess that doesn't make a difference there... so. I think that is going to answer all my questions.

**Focus Group Meeting**

**May 18, 2012, 2:40 pm**

**HTCS**

Paul:

This is May 18<sup>th</sup>, this is HTCS, and these are students who built the BalloonSat. I want to let you know your names are going to be removed... and I'll replace with a single letter or... or a... initials... or a number or something like that, so when it's all done... they'll know if two students... talked two or three times, but they won't know who it is. Okay. So you're anonymous here... so you're free to talk... this does not show up as a grade for you... or anything like that, okay.

Okay, so what I've... what I've got is about six questions that I'm going to be asking... and the first one involves the question about doing this BalloonSat project and did it change your impression about the usefulness of science. So what... I'm going to have three different questions that I would like to ask about that. So first off is I would like to get your feeling on... is science answering important questions and what are some examples of important questions. So does science answer important questions and can you give me an example of important questions?

E:

Yeah... yes, it tells you how to do something or what makes something happen in like uh... we did make ice cream I guess as a lab in science class, so it answers how you do stuff and... what the effects are.

Paul:

Okay... does it have to be something physical... or can it be ideas... so what, what do... you talk about things, what kinds of... things do you mean when you say things?

PAUSE

Paul:

So, so... some more like in depth... examples. Or would someone else like to add to that?

D:

Yeah... and uh... it like... like it just what is out there, what's out there? I guess.

Laughter

Paul:

So what's out... what's out where?

D:

Ah... out in the world, out in the universe.

Paul:

So what's out in the universe, okay... okay. So okay, next question, is... is science cost effective for the benefit. So is science... is it too expensive,



The school made announcements at this time

Paul:

Is science cost effective for the benefit. So is science... is it too expensive... just right... or is it a bargain. Are we getting a lot more than we bargained for... or do we get a good match for our money, or are spending too much.

F:

Um... and yes it's worth the money, like...

Paul:

Okay, can you give me some examples of why you would think that it's worth the...

F:

Well, because it helps us to understand the world we live in and then it helps us to find like how to cure diseases and stuff.

Paul:

Okay, so I'm seeing some applications... okay. Does anyone else want to add to that?

G:

Well, like if there's some new disease... and... we don't spend any money... like as much money as possible... um... on finding a cure... then... the cost of the... of like... like the human life... that would be lost... would... would outweigh... the money... that you would spend on solving the problem.

Paul:

What if no life was lost though?

F:

Well then we would... like... in... response to. Like if we save them, and they would have died, or is it just like?

Paul:

Let's say it's a disease that people don't die from... but it is a disease.

I didn't realize that one of the students in the focus group (E) was diabetic and wearing an insulin pump.

F:

If it improves their life style then... it might... be worth it.

E:

I think like in risk of lives... it could improve your life, so you wouldn't be like... like... it's a quality of life that matters... not the quantity.

PAUSE

E:

Like people with diabetes ah... because...

LAUGHTER

E:

Yeah, okay.

Paul:

Does anyone else have anything they would like to add to that?

No Response

Paul:

Okay, so now what kind of risks does science present to society? So every kind of activity that we do, like driving or something like that, there's a benefit and there's also a risk. So what kind of risk does society... excuse me, what kind of risk does science present to society. So for example, there are two views, it's acceptable... there are very few of them... or it there are a lot, maybe too many.

F:

Like nuclear testing plants... like those can be dangerous to the people that are working there.

Paul:

What can be dangerous?

F:

Ah like the nuclear... um energy...

A student says radiation

F:

...yeah radiation... and... but then there's like other risks that aren't as big, but like... like you could be testing something and then it exploded and it could be potentially dangerous

LAUGHTER

F:

And so ah... um... yeah, and then there's like not... and there's other things that's not as many risks... for like science.

Paul:

So what about science just overall... so you gave some examples where there is risk or no risk, but what about just generally overall... if you're looking...

F:

Well... for the most part, there's not very many risks to science.

Paul:

Okay, does anyone else have anything that'd like to add to that? Or, or do you want to reply, or do you disagree?

No reponse

Paul:

Okay. Those were three questions on how BalloonSats may have changed your

impression about the usefulness of science. So now I would like to... talk to you about what kind of a person can be a scientist. Okay.

The teacher entered the room to let us know some parents were waiting

Paul:

Okay, so now... here's the question I have for you. If you lived next door to a scientist... suppose your neighbor was a scientist. What would this person look like?

E:

They could look like anyone. They could be... like... like it doesn't matter. Like anyone could be a scientist, if they go to school and study. You know.

Paul:

So going to school and studying doesn't make you any different?

E:

No. You can be smart, and you can be like... look the same as everyone else.

Paul:

Okay. Is there something anyone would like to add to that?

No reply

Paul:

Okay. What kind of activities would this person do after work? So, a scientist has to be at a job some place, and he or she will come home... what would they do after work, or on weekends... when they're not at work?

D:

Ah... they'd probably do just the same... like things we do, like... go out to eat... ah... I don't know, shop... like... go like... swimming or anything. They're just like us. It's they just have a different profession.

Paul:

Okay... does anyone have something to add to that?

H:

Well, ah... like... a normal... smart person... could like choose to be an athlete... and then they wouldn't really be recognized for having superior knowledge... but if... like someone could be scientist and people would not know it, because if they play sports or anything... then they, people would just... and they just playing like in a sports team, then people would just think that's a guy who's just good at basketball... not he's a scientist... from KU, or something.

Paul:

Okay... so the next question is what kind of family would this person have? So we're going to suppose that this scientist, male or female... could have a family... and what kind of a family could they have?

E:

They could have a normal family, like a wife, and... two kids... or like... just a wife... or kids, it doesn't matter because like... they're not any different than the rest of us, they're just... interested in something other than what... other people would be interested in than... that doesn't mean they can't have the same wife and family that we can.

I:

I agree.

Paul:

Ah... so now we'll look at the usefulness of science in discovering knowledge. So here I've got some... couple of questions... are they're any important questions that science cannot answer... even if we gave it enough time. So we're looking at questions that are important to know... are there things that science couldn't answer... ah... if even you gave it a thousand years to do it.

I:

Well I kind of think so... because like... we've been trying to figure out... like how the world started... and like... there's no way we can really figure it out.

Paul:

Would anyone else like to add to that?

E:

But like, back like... they don't know everything, that like happened, like, I don't know... like... 2,000 years ago or something... like they don't know what people's faces looked like back then, they don't know what Jesus looked like... they don't know like... have ideas of like... how everything happened... they have educated guesses, they don't know, or they can't prove it for sure.

Paul:

Anything else? Okay... so... um, next one would be... we've talked about questions that science couldn't answer...so there are some questions... that we... that are out there and are important... and I'm wondering are there questions that are best that science didn't even investigate. So is there any questions that you can think of... that are important to you... or to other people... are there areas that science should not be investigating?

D:

They probably shouldn't be investigating like... I don't know... people's attitude, maybe... like if maybe someone like a... like a not a very good person, then they should not investigate like why certain people are mean and why certain people are like nice. I dunno know.

G:

I don't think they should a... will not... they should probably study it but not really... investigate in genetically engineering... like... I wouldn't say... yeah like people... I mean... because it's kind of like the way that we're... created and if you change that then... like it's not really... if you... change someone... like



change the way someone is... are they really living their life, or are they just living the way you want them to?

Paul:

Okay, now are there some questions that should just be left as mysteries? Are there just some things that we just don't want to answer? You know... that science shouldn't even try to answer? Just because it's better to leave them as a mystery.

E:

I think like that some things like how people think about certain things... like... have a positive attitude or negative attitude or a positive effect or a negative effect... shouldn't really be studied... in like... our feelings... like it should just like.. left for us to feel or experience and so like... not only do I know that this is going to happen, I know that's going to happen, like know how everything is going to go. Because it won't be... like fun or exciting... or you wouldn't really have feelings, like that.

G:

Like... if you... like super... analyze something... and you think you know something about it... that wasn't meant to be... like for you to know everything about it... like that's part of... like... the mystery of it.

Paul:

Okay, so now we're going to look at um... the importance of being open-minded and ready to revise your thoughts and plans because science kind of emphasizes being open-minded and be ready to change your... your thoughts or your plans if something... evidence is... is presented. So the question I like to ask is when you

guys were building your BalloonSat... do you feel like... you best knew how to build the BalloonSat. Did... did you think that, "I know how to do this, and I ah... don't need someone else to tell me how to do this... I know what I'm doing.

G:

No.

Paul:

Do you want to elaborate on that?

G:

There were some things that we didn't have experience in... like... 70 percent of the stuff... or more... and... some... we need to ask someone who knew more than us about it.

I:

I would say no because like... people have like different talents like... J, he was in our group... he know how to solder and everything. And like G... ah like I don't know where we have been because like he did like the computers... so like... you all need to work in a good group.

E:

No. Because I think like we didn't know all the technology stuff, or how to program boards. So, if you tried to do that we would have like probably like messed the whole project up. And we didn't know like... exactly what we were

doing... we could have figured some stuff out, but we needed some guidance.

Paul:

Okay so you kind of answered the second one here... when you were building your BalloonSat, did somebody other than you have a good idea and where they able to convince you... that it was a good idea and you should do it their way? And can you give an example of where... where that might have happened?

D:

Ah... well one of the people in our group... in our group ah... he was... oh he was ah... like getting all the parts and telling us where they go and he put the wrong one in the wrong spot... like... and... some kid was saying, "I don't think that's the right one", because there were two that looked the same, they... they were telling him to check it, but he said they were the same... and they said they were like the same part... and so we soldered it in... and it was the wrong one... and so, well... we should have listened to him, like the people who were saying it was the wrong part. Because if we had we wouldn't have to... go through all the steps to remove that piece and get a new one.

Paul:

So that's... that's an example of someone ah... not being convinced.

I:

Yeah, well yeah.

Paul:

Is there examples of where someone was convinced?

I:

Um... yes, because this... this same person was putting in one piece... and it looked exactly the same... and so... they were ah... we were kind of arguing about it and then we put in the other one, and it was the right one. So... if we had soldered that in... we had to fix.

Paul:

Okay.

E:

We... when we were doing one of the circuit boards... we... put a piece in... but like... like the way we matched it up was backwards, we need to flip it the other way... and ah... and when, I think it was me in the group was putting it in...and I didn't realize that I was putting it in backwards... that I didn't know to which to specific it was suppose to go... and it was suppose to go the other way... someone was tracking it and told me it needs to go the other way... and like checked the packet and everything and... that was right.

Paul:

Okay... um... this is not you, this is everybody else on your BalloonSat team, okay... so this is not you. Do you fell like everybody else in your BalloonSat team was pretty clueless? Of how to do the BalloonSat? So not you, but like everybody else on your team... were they like clueless when building the

BalloonSat?

Teacher enters the room to remind us that some students might have to leave now.

D:

Ah... ah well... some... most of the kids in our group knew how to solder already so... they kind of knew what to do and where to put things but... naw, so... they were kind of how to do it.

I:

We probably would have like... destroyed the thing if we didn't have directions... so we definitely needed that... so I kind of think, yeah.

Paul:

Okay, so the next question I have now is... for the science classes you will take in the future. So kind of thing at the beginning of this semester... what were you planning to take for science classes in the future... and, and compare it to now. Have your plans changed on what science classes you were planning to take.

D:

I didn't really think... that much about like taking... like... really, really big science classes, I just kind of... I mean I'm going to take... some kind of science class, but now... after I did the BalloonSat... it was really fun and I want to take like more advanced science classes... and like... do like science classes where I can do a lot of projects and build things... so...

E:

Before like... the BalloonSat project I didn't really like... want go far into science... so like I was in college or... going beyond that or anything, I just wanted to ah... like... take other classes, I guess just take it... the minimum and skip it... but like... since we, like this year... I want to like... take science like all through my years of going to school...and be like in a science field... or be like a doctor or like... a vet of something.

G:

Before BalloonSat, I kind of wanted to do... like... things... like how to relate to physics and how else how stuff works. Um... and after BalloonSat... I still kind of want to do that, but I kind of have a little more... like... more... I kind of want to do... it might be interesting to do something like with... like circuit boards, computers or something.

Paul:

Okay, so next I would like to find out what your hobbies are... that are science related. Any kind of current science hobbies?

D:

I don't know if this is really science related but I play like a lot of video games... like on the weekends and stuff... so like... I guess it's science-related, but I like that they have to put circuit boards into the system to make it... ah, and like create the video games on computers and everything.

Paul:

Does anyone else have to add to that?

G:

Yeah, I like video games, but... also... I, I don't know if it's science related, quote-unquote, but would photography count? Because you like... visual imaging and stuff and... and also like photo manipulation in like Photoshop and other things.

Paul:

Okay, so now what hobbies do you want to start now... that hadn't thought about starting before, or weren't doing before.

D:

Um... I think ah I would probably like to start a hobby like... like make... like... adjusting like circuit boards and things and... and like... changing it, like I don't know how... but like... you can mod stuff and things like on video games...

like... and make like... people run faster if you just change things like one little thing in the controller... like... in the controller, ah... chip, so I don't know, I might start doing that, like taking a part controllers, so (LAUGHS).

Paul:

So I would like to know what science museums have you visited before. So what kind of science museums have you gone to before?

D:

Ah... in fifth grade... ah... we went down to the like Natural History Museum in

Lawrence. And we like... ah had like a... like a... hunt and in which we had to find like all the things... like... um... like ducks... and animals... and like bugs... we had to find certain things in the museum. And we went to Science City... to just kind of like a play place.

G:

Like once my sister had a gymnastics meet... it was just this year ah... my sister had a gymnastics meet in St. Louis... and we went to the ah... science museum there... when while we were like there... ad it was pretty cool.

Paul:

Okay... so what science museum would you do think you want to visit now, or in the future? In the next few years... do you want to go visit some new ones, or do you know some ones you would like to visit. Or if you don't know a museum, do you have some type of museum you want to visit?

D:

Um... isn't there like a science museum in Cleveland? Like ah... I don't know, I think I've been to it before, it was... I would like to visit that again, because it was really cool like...

Teacher entered room asking how much longer the interviews would need

D:

So I'd been there before... it was like really fun, we got to do a lot of like... experiments in there, they like had them set up, and if like... the plasma thing



where you all went and touched it...

Paul:

What... what about the future?

D:

Ah...in the future, I don't know... like archeology museums maybe? I kind of...  
kind of like... fossils.

Paul:

So you would you top add fossils?

D:

Yeah

Paul:

Would anyone else like to add to that?

No response

Paul:

Okay... um... is there, I don't know if you have a science club in this school?

Students:

Not really

Paul:

Okay... um... do you have any kind of science-related activities after school? I don't know what they provide in this town... is there any kind of... do you have scouts or 4H or something like that? Do they have some kind of science-related activity that you could do? And do you belong to it, or are you involved with it?

Students indicate there are no science-related after-school activities in town.

Paul:

Let's talk about your plans for after graduation. Think about the beginning of this semester... what you thought you might do after graduation... and think of what you might want to do now... that's it now the end of the school year. What's your plans for graduation, did they change, did they stay the same, but I would also like to hear what your plans were... or are.

I:

Well, I'm looking forward to getting my permit to drive. Yeah... I think that would be great and cool, because you could drive... and... I've been looking forward to doing that.

Paul:

What... what about education?

I:

Um... we could drive places.

Students laugh

Paul:

No, no. What are your places after school?

I:

You mean like high school?

Paul:

Yeah... that might be an example. Or college

I:

Um... well, I'm looking forward to going to high school (laughs)... I really don't know.

Paul:

Okay

D:

I really did use to think about like... college that much, but then like... once I started to... I think... mainly this year... then I started thinking about high school... well and um... I just started like doing a lot... of science experiments and stuff... I kind of wanted to... and I was watching like the science-related kind of shows... ah... I thought about getting like a better education and I would like... would like to get accepted into a really good school like... Harvard or...

like... Yale.

Paul:

Has that changed this year?

D:

No.

Paul:

Okay. The next question I have is how your... how males and females, or boys and girls, worked on the BalloonSats. Do you think there was a difference in the way that boys and girls, or males and females worked on the... on the BalloonSat?

D:

Uh... I think the... we kind of did more of the work and the just kind of copied off of us. Like they'd come over and ask us what that was and then they'd put it in. So they'd... we'd do it and they... like... copied it... I guess.

Paul:

Does somebody else have anything to add to that?

G:

Ah... I don't notice that they're copying off us... I mean they might have been...

but... like this goes back to earlier question... like... we asked... the electrician who came here to our room... for (laughs – because I was pretending to be an electrical engineer from KU when they needed help) for certain... for certain things and so they... put... we were basically equal... like in our progress in things. Um... I don't know about what happened when their circuit board didn't work... theirs didn't collect data when ours did. I don't know.

I:

I think they did copy off us rather a lot... because like... they would come over and like, “where does this go”? And we would go, “right over there” And they would go, “Okay, thank you”. And they would put it in. So I think we did a little more work.

Paul:

So does anyone else have anything else to say about the BalloonSat project... this whole thing you did this semester with building this BalloonSat, getting it launched, and getting your data, and looking at your pictures?

D:

I would just like to say that it was a really cool experience and I never thought I'd get the chance to do that.

G:

It was long... and I never knew that so much work went into... sending up the little box... that took pictures.

I:

It was pretty long... but...I didn't know it took so much time to make a computer chip... because like... there are a lot of those and any electronic thing... it took us along time to make just one of them... so... it must take them forever.

G:

Also... will they had... so like really... like instructions... and everything. But um...also... I think because we just had 40 hours a day... minutes a day to work on it... um... and... they have all day to like work on one circuit chip... and... also like... we would do one days, stop...and then pick it up another day, but not really knowing where we left off. And... and after a while, some people decided to take a little break... from working on it. So... yes, I guess that also factored into it. But, yeah... it was a fun project.

## APPENDIX E

### Letter to High School Principal Requesting Participation

November 21, 2011

Principal's Name

School Address

City, State, Zip Code

Dear (Principal's Name)

I am a doctoral student at the University of Kansas in the School of Education. As part of the requirements of my doctoral dissertation, I am conducting a research study to measure the impact that participation in a BalloonSat project has on students' attitude toward science.

The project-based learning activity involves the design, assembly, and evaluation of a functioning model of a satellite. All the materials for the BalloonSat and its flight will be provided at no cost. At the end of the activity, students will science data to analyze that was collected during a balloon flight to 80,000 feet. The students in (teacher's name and class) are being invited to participate in this study. As a part of the research procedures, a pre and post survey (called TOSRA) will be given to all participating students. The first survey will be administered between mid-December and early January with a follow-up survey administered in late April. The survey will take approximately 20 minutes to complete. All materials to administer and return the survey to the researcher will be provided.

In addition to participating students, a matched sample of students who are not building the BalloonSat, but who are in the same classroom will also be asked to participate in the survey. This will be accomplished through the help of (teacher's name). Therefore, if there are ten students building the BalloonSat, an additional ten non-BalloonSat students will also be surveyed.

(teacher's name) will be requested to perform the following tasks associated with the research study:

8. Facilitate completion of student/parent consent forms.
9. Facilitate the completion of the research surveys.
10. Return the completed consent forms and surveys within five (5) business days after being completed by students.

In addition to the survey, I would like one of the BalloonSat builders as well as (teacher's name) to participate in an hour-long focus meeting. The date of the meeting will be in late April and will be after school hours at the University of Kansas. I will contact you and the BalloonSat team with the exact time and location of the meeting closer to the date.

The information for the surveys and focus meeting will allow us to know more about the impact of BalloonSats as a project-based learning activity on middle and high school students' attitudes in science. Given the potential large sample size, the findings of this study may prove significant. Participation in this research study is voluntary. Your school and students are free to discontinue participation at any time without penalty.

I am the Principle Investigator on this graduate student dissertation research study and can be contacted at (785) 230-6866 for more information regarding this study. My work is being supervised by my advisor, Dr. Jim Ellis at the University of Kansas and he may be contacted at (785) 864-9847.

Enclosed you will find a copy of a consent form for you to sign and return to me so that I can send the BalloonSat kit and surveys to (teacher's name). Please feel free to sign and email me a scanned copy of the consent form. Also enclosed is a copy of the attitude survey for your review.

Your assistance in this research study is greatly appreciated.

Sincerely,

L. Paul Verhage

nearsys@gmail.com



## APPENDIX F

### High School Participation Agreement

(Name of School) School Participation Agreement

Students attending (name of school) have permission to participate in the research subject to investigate whether participation in a BalloonSat project-based learning activity increases student positive attitudes and interest in science more than not participating in the program.

I understand participation in this research study is entirely voluntary and my decision whether to participate or not to provide permission for (teacher's name) students to participate will involve no penalty or loss of benefits to which the students are otherwise entitled.

I furthermore understand that my decision to provide permission for (teacher's name) students to participate does not obligate students to participate and that each student is free to discontinue participation at any time without penalty or loss of benefits to which he/she is otherwise entitled.

I understand that L. Paul Verhage is the Principle Investigator on this graduate student dissertation research study and he may be contacted at (785) 230-6866 for more information regarding this study. His work is being supervised by Dr. Jim Ellis at the University of Kansas and he may be contacted at (785) 864-9847.

My signature below indicates that:

8. I have read and understand the information provided above, and that I am willing to provide permission for students enrolled in (teacher's name) class to participate in this research study.
9. I may withdraw my consent at any time and discontinue participation at any time without penalty or loss of benefits to which my students may be otherwise entitled.
10. I am not waiving any legal claims, rights, or remedies.

---

Print Name

---

Signature

## **APPENDIX G**

### **Parental Permission Agreement**

#### **THE EFFECT OF THE BALLOONSAT PROJECT ON MIDDLE AND HIGH SCHOOL STUDENTS' ATTITUDE TOWARD SCIENCE**

##### **INTRODUCTION**

The Department of Curriculum and Teaching at the University of Kansas supports the practice of protection for human subjects participating in research. The following information is provided for you to decide whether you wish your child to participate in the present study. You may refuse to sign this form and not allow your child to participate in this study. You should be aware that even if you agree to allow your child to participate, you are free to withdraw at any time. If you do withdraw your child from this study, it will not affect your relationship with this unit, the services it may provide to you, or the University of Kansas.

##### **PURPOSE OF THE STUDY**

The purpose of this study is to measure the impact of participation on the BalloonSat project on student attitude toward science. It is hypothesized that gender, age, past science activities, and neighborhood will be associated with their views on science and this study will attempt to examine these factors.

##### **PROCEDURES**

Your child will be asked to participate in two attitude surveys (the results are kept confidential) and a BalloonSat activity in your science class during the 2012 spring semester. In addition, your child will be asked to participate in a one hour focus meeting to further discuss your attitude toward science and the BalloonSat project. The focus group will be audio recorded; the recording will only be used by the researcher and will be stored in a locked storage cabinet.

##### **RISKS**

No burdens, inconveniences, pains, discomforts, or other risks are anticipated as a result of participation in this study.

## BENEFITS

While doing background reading for this study, I found that researchers report that students participating in robotics projects had statistically significant higher attitudes toward science, technology, engineering, and mathematics compared to students who do not participate in robotics. My study builds upon this previous work and will measure the impact that a BalloonSat project has on students' attitude towards science. This study will also attempt to examine background variables that are associated with positive experiences because of participation in the BalloonSat project. The study will provide valuable information to administrators and teachers wishing to implement BalloonSats in their schools as a way to increase students' interest in science.

## PAYMENT TO PARTICIPANTS

All materials are provided in this study and therefore there are no payments to the participants.

## PARTICIPANT CONFIDENTIALITY

Your child's name will not be associated in any way with the information collected about your child or with the research findings from this study. The researcher will use a study number or a pseudonym instead of your child's name. The research will not share this information about your child unless required by law or unless you give written permission,

Permission granted on this date and use to disclose your information remains in effect indefinitely. By signing this form, you give permission for the use and disclosure of your child's information, excluding your child's name, for purposes of this study at any time in the future.

## REFUSAL TO SIGN CONSENT AND AUTHORIZATION

You are not required to sign this Consent and Authorization form and you may refuse to do so without affecting your right to any previous services you are receiving or may receive from the University of Kansas or to participate in any programs or events of the University of Kansas. However, if you refuse to sign, your child cannot participate in this study.

## CANCELLING THIS CONSENT AND AUTHORIZATION

You may withdraw your consent to allow participation of your child in this study at any time. You also have the right to cancel your permission to use and disclose information collected about your child, in writing, at any time, by sending your written request to: L. Paul Verhage, 6114 SW

27<sup>th</sup> #3, Topeka, KS 66614. If you cancel permission to use your child's information, the researcher will stop collecting additional information about your child. However, the researcher may use and disclose information that he has gathered before he received your cancellation, as described above.

#### QUESTIONS ABOUT PARTICIPATION

Questions about procedures should be directed to the researcher listed at the end of this consent form.

#### PARTICIPATION CERTIFICATION:

I have read this Consent and Authorization form. I have had the opportunity to ask, and I have received answers to, any questions I had regarding the study. I understand that if I have any additional questions about my child's rights as a research participant, I may call (785) 864-7429 or (785) 864-7385 or write Human Subjects Committee Lawrence Campus (HSCL), University of Kansas, 2385 Irving Hill Road, Lawrence, Kansas 66045-7563, email irb@ku.edu.

I agree to allow my child to take part in this study as a research participant. By my signature I affirm that I have received a copy of this Consent and Authorization form.

---

Type/Print Participant's Name

---

Date

---

Parent/Guardian Signature

Research Contact Information

L. Paul Verhage

Jim Ellis, Ph.D.

Principle Investigator

Dept. Curriculum and Teaching

School of Education

1122 West Campus Road

Room 346

Lawrence, KS 66045

Room 346

Lawrence, KS 66045

Faculty Supervisor

Dept. Curriculum and Teaching

School of Education

1122 West Campus Road

University of Kansas

(785) 864-9847

University of Kansas

(785) 864-9847

## **APPENDIX H**

### **Codes Used for Transcript Analysis**

#### **BalloonSat**

Difficulty

Enjoyable elements

#### **Gender**

Gender roles

Gender capabilities

#### **Future Plans**

Science classes

Careers

#### **Science**

Benefits

Limitations

Boundaries

Hobbies and activities

**APPENDIX I**

**Results for Primary Research Question #1**

**Responses from TOSRA Survey**

<b>Question #</b>	<b>N</b>	<b>Strongly Disagree %</b>	<b>Disagree %</b>	<b>Not Sure %</b>	<b>Agree %</b>	<b>Strongly Agree %</b>	<b>Mean</b>
Money spent on science is well worth spending.  (Q1)	<u>Treatment</u>						
	Pre (N=95)	.0	1.1	2.0	42.1	36.8	4.15
	Post (N=75)	.0	.0	12.0	42.7	45.3	4.33
	<u>Control</u>						
	Pre (N=88)	1.1	1.1	15.9	54.5	27.3	4.06
	Post (N=63)	.0	1.6	9.5	5.8	38.1	4.25
Science is man's worst enemy.  (Q8)	<u>Treatment</u>						
	Pre (N=95)	61.1	23.2	13.7	2.1	.0	1.57
	Post (N=75)	57.3	36.0	6.7	.0	.0	1.49
	<u>Control</u>						
	Pre (N=88)	48.9	28.4	14.8	4.5	3.4	1.85
	Post (N=63)	55.6	27.0	14.3	.0	3.2	1.68



Public money	<u>Treatment</u>						
spent on science	Pre (N=95)						
in the last few		.0	4.2	58.9	3.5	6.3	3.39
years has been	Post (N=75)						
used widely.		.0	4.0	44.0	41.3	1.7	3.59
(Q15)	<u>Control</u>						
	Pre (N=88)	2.3	3.4	53.4	34.1	6.8	3.40
	Post (N=63)	1.6	4.8	38.1	38.1	17.5	3.65
Scientific	<u>Treatment</u>						
discoveries are	Pre (N=95)	33.7	36.8	27.4	2.1	.0	1.98
doing more harm	Post (N=75)	3.7	41.3	22.7	4.0	1.3	2.04
than good.							
(Q22)	<u>Control</u>						
	Pre (N=88)	33.7	36.8	27.4	2.1	.0	2.24
	Post (N=63)	3.2	38.1	25.4	1.6	4.8	2.13
The government	<u>Treatment</u>						
should spend	Pre (N=95)						
more money on		27.3	37.5	25.0	4.5	5.7	3.49
scientific	Post (N=75)						
research.		1.3	1.7	36.0	38.7	13.3	3.52
(Q29)	<u>Control</u>						

	Pre (N=88)	1.1	5.3	48.4	33.7	11.6	3.42
	Post (N=63)	1.6	17.5	38.1	27.0	15.9	3.38
Too many laboratories are being built at the expense of the rest of education.	<u>Treatment</u>						
	Pre (N=95)	15.8	26.3	53.7	4.2	.0	2.46
	Post (N=75)	13.3	26.7	56.0	4.0	.0	2.51
(Q36)	<u>Control</u>						
	Pre (N=88)	9.1	25.0	55.7	6.8	3.4	2.70
	Post (N=63)	3.2	25.4	58.7	11.1	1.6	2.83
Science helps to make life better.	<u>Treatment</u>						
	Pre (N=95)	.0	2.1	26.3	35.8	35.8	4.05
	Post (N=75)	.0	.0	13.3	53.3	33.3	4.20
(Q43)	<u>Control</u>						
	Pre (N=88)	1.1	3.4	2.5	42.0	33.0	4.02
	Post (N=63)	1.6	3.2	12.7	46.0	36.5	4.13
This country is spending too much money on science.	<u>Treatment</u>						
	Pre (N=95)	23.2	31.6	43.2	2.1	.0	2.24
	Post (N=75)	16.0	46.7	3.7	6.7	.0	2.28

(Q50)	<u>Control</u>						
	Pre (N=88)	14.8	34.1	39.8	8.0	3.4	2.51
	Post (N=63)	11.1	31.7	52.4	3.2	1.6	2.52
Science can help	<u>Treatment</u>						
to make the	Pre (N=95)						
world a better		2.1	.0	21.1	29.5	47.4	4.2
place in the	Post (N=75)						
future.		.0	.0	1.7	34.7	54.7	4.44
(Q57)	<u>Control</u>						
	Pre (N=88)	1.1	1.1	1.2	35.2	52.3	4.36
	Post (N=63)	.0	1.6	17.5	33.3	47.6	4.27
Money used on	<u>Treatment</u>						
scientific projects	Pre (N=95)						
is wasted.		35.8	43.2	21.1	.0	.0	1.85
	Post (N=75)						
		28.4	48.6	18.9	2.7	1.4	2.00
(Q64)	<u>Control</u>						
	Pre (N=88)	27.3	37.5	29.5	2.3	3.4	2.17
	Post (N=63)	31.7	33.3	28.6	4.8	1.6	2.11

**Test of the Homogeneity-of-Slopes Assumption**

<b>Source</b>	<b>Type III Sum of Squares</b>	<b>df</b>	<b>Mean Square</b>	<b>F</b>	<b>Sig.</b>	<b>Partial <math>\eta</math> Squared</b>
Corrected Model	891.76	3	297.25	14.32	.00	.24
Intercept	1065.07	1	1065.07	51.32	.00	.28
PreS	805.31	1	805.31	38.81	.00	.23
BalloonSat	32.79	1	32.79	1.58	.21	.01
BalloonSat*PreS	36.50	1	36.50	1.76	.19	.01
Error	278.74	134	2.75			
Total		138				
Corrected Total		137				

**Test of the Main Effect and the Covariate for the One-Way ANOVA**

<b>Source</b>	<b>Type III Sum of Squares</b>	<b>df</b>	<b>Mean Square</b>	<b>F</b>	<b>Sig.</b>	<b>Partial <math>\eta</math> Squared</b>
Corrected Model	855.25	2	427.63	2.49	.00	.23
Intercept	1102.11	1	1102.11	52.81	.00	.28
PreS	79.62	1	79.62	37.89	.00	.22
BalloonSat	3.62	1	3.62	.17	.68	.00

Error	2817.24	135	2.87
Total	21529.00	138	
Corrected Total	3672.49	137	

**APPENDIX J**

**Results for Primary Research Question #2**

**Responses from TOSRA Survey**

<b>Question #</b>	<b>N</b>	<b>Strongly Disagree %</b>	<b>Disagree %</b>	<b>Not Sure %</b>	<b>Agree %</b>	<b>Strongly Agree %</b>	<b>Mean</b>
Scientists usually like to go to their laboratories when they have a day off.	<u>Treatment</u>						
	Pre (N=95)	4.2	17.9	54.7	21.1	2.1	3.0
	Post (N=75)	4.0	18.7	57.3	17.3	2.7	3.0
(Q2)	<u>Control</u>						
	Pre (N=88)	3.4	11.4	61.4	18.2	5.7	3.11
	Post (N=63)	1.6	9.5	61.9	19.0	7.9	3.22
Scientists are about as fit and healthy as other people.	<u>Treatment</u>						
	Pre (N=95)	1.1	9.5	35.8	38.9	14.7	3.6
	Post (N=75)	.0	2.7	32.0	44.0	21.3	3.8

(Q9)	<u>Control</u>						
	Pre (N=88)	5.7	12.5	39.8	29.5	12.5	3.31
	Post (N=63)	7.9	7.9	38.1	33.3	12.7	3.35
Scientists do not have enough time to spend with their families.	<u>Treatment</u>						
	Pre (N=95)	5.3	36.8	48.4	7.4	2.1	2.6
	Post (N=75)	12.0	28.0	48.0	1.7	1.3	2.7
(Q16)	<u>Control</u>						
	Pre (N=88)	3.4	15.9	65.9	1.2	4.5	2.97
	Post (N=63)	7.9	2.6	65.1	3.2	3.2	2.73
Scientists like sports as much as other people do.	<u>Treatment</u>						
	Pre (N=95)	1.1	5.3	5.5	31.6	11.6	3.5
	Post (N=75)	1.3	1.3	4.0	41.3	16.0	3.7
(Q23)	<u>Control</u>						
	Pre (N=88)	2.3	6.8	46.6	31.8	12.5	3.45
	Post (N=63)	3.2	6.3	34.9	38.1	17.5	3.60
Scientists are less friendly than other people.	<u>Treatment</u>						
	Pre (N=95)	29.5	34.7	33.7	2.1	.0	2.1
	Post (N=75)	36.0	26.7	33.3	2.7	1.3	2.1

(Q30)	<u>Control</u>						
	Pre (N=88)	28.4	31.8	33.7	2.1	.0	2.19
	Post (N=63)	14.3	41.3	39.7	3.2	1.6	2.37
Scientists can have a normal family life.	<u>Treatment</u>						
	Pre (N=95)	.0	1.1	17.9	38.9	42.1	4.2
	Post (N=75)	.0	2.7	18.7	36.0	42.7	4.2
(Q37)	<u>Control</u>						
	Pre (N=88)	1.1	3.4	19.3	38.9	42.1	4.08
	Post (N=63)	.0	1.6	14.3	54.0	3.2	4.13
Scientists do not care about their working conditions.	<u>Treatment</u>						
	Pre (N=95)	31.6	28.4	36.8	2.1	1.1	2.1
	Post (N=75)	32.0	34.7	29.3	4.0	.0	2.1
(Q44)	<u>Control</u>						
	Pre (N=88)	27.3	31.8	3.7	8.0	2.3	22.6
	Post (N=63)	28.6	33.3	33.3	4.8	.0	2.14
Scientists are just as interested in art and music as other people are.	<u>Treatment</u>						
	Pre (N=95)	2.1	5.3	36.8	38.9	16.8	3.6
	Post (N=75)	.0	2.7	28.0	48.0	21.3	3.9



(Q51)	<u>Control</u>						
	Pre (N=88)	4.5	3.4	39.8	35.2	17.0	3.57
	Post (N=63)	.0	4.8	28.6	39.7	27.0	3.89
Few scientists are happily married.	<u>Treatment</u>						
	Pre (N=95)	23.2	2.0	51.6	4.2	1.1	2.4
	Post (N=75)	29.3	2.0	4.0	8.0	2.7	2.4
(Q58)	<u>Control</u>						
	Pre (N=88)	22.7	17.0	48.9	9.1	2.3	2.51
	Post (N=63)	12.7	28.6	46.0	11.1	1.6	2.60
If you met a scientist, he/she would probably look like anyone else you might meet.	<u>Treatment</u>						
	Pre (N=95)						
	Post (N=75)	2.1	2.1	17.9	35.8	42.1	4.1
		1.3	2.7	12.0	4.0	44.0	4.2
(Q65)	<u>Control</u>						
	Pre (N=88)	.0	4.5	15.9	4.9	38.6	4.14
	Post (N=63)	1.6	4.8	12.7	39.7	41.3	4.14

**Test of the Homogeneity-of-Slopes Assumption**

<b>Source</b>	<b>Type III Sum of Squares</b>	<b>df</b>	<b>Mean Square</b>	<b>F</b>	<b>Sig.</b>	<b>Partial <math>\eta</math> Squared</b>
Corrected Model	1148.85	3	382.95	2.15	.00	.31
Intercept	451.18	1	451.18	23.75	.00	.15
PreN	962.11	1	962.11	5.65	.00	.27
BalloonSat	2.84	1	2.84	1.10	.30	.01
BalloonSat*PreN	25.67	1	25.67	1.35	.25	.01
Error	2546.13	134	19.00			
Total	192543.00	138				
Corrected Total	3694.99	137				

**Test of the Main Effect and the Covariate for the One-Way ANOVA**

<b>Source</b>	<b>Type III Sum of Squares</b>	<b>df</b>	<b>Mean Square</b>	<b>F</b>	<b>Sig.</b>	<b>Partial <math>\eta</math> Squared</b>
Corrected Model	1123.19	2	561.59	29.48	.00	.31
Intercept	433.83	1	433.77	22.77	.00	.14
PreN	1019.64	1	1019.64	53.52	.00	.28
BalloonSat	14.10	1	14.10	.74	.39	.01

Error	2571.81	135	19.05
Total	192543.00	138	
Corrected Total	3694.99	137	

**APPENDIX K**

**Results for Primary Research Question #3**

**Responses from TOSRA Survey**

<b>Question #</b>	<b>N</b>	<b>Strongly Disagree</b>	<b>Disagree</b>	<b>Not Sure</b>	<b>Agree</b>	<b>Strongly Agree</b>	<b>Mean</b>
		<b>%</b>	<b>%</b>	<b>%</b>	<b>%</b>	<b>%</b>	
I would prefer to	<u>Treatment</u>						
find out why	Pre (N=95)						
something							
happens by doing	Post (N=75)	1.1	2.1	1.5	32.6	53.7	4.4
an experiment							
than be being		1.3	8.0	13.3	33.3	44.0	4.1
told.							
(Q3)	<u>Control</u>						
	Pre (N=88)	2.3	8.0	19.3	25.0	45.4	4.0
	Post (N=63)	1.6	9.5	14.3	33.3	41.3	4.0
Doing	<u>Treatment</u>						
experiments is	Pre (N=95)	43.2	37.9	9.5	6.3	3.2	1.9
not as good as							
finding out	Post (N=75)	3.7	42.7	17.3	9.3	.0	2.1
information from							

teachers.

(Q10)	<u>Control</u>						
	Pre (N=88)	31.8	38.6	18.2	8.0	3.4	2.1
	Post (N=63)	25.4	46.0	15.9	9.5	3.2	2.2
I would prefer to do experiments rather than to read about them.	<u>Treatment</u>						
	Pre (N=95)	1.1	2.1	6.3	37.9	52.6	4.4
	Post (N=75)	2.7	1.3	8.0	44.0	44.0	4.3
(Q17)	<u>Control</u>						
	Pre (N=88)	2.3					4.3
			3.4	14.8	26.1	53.4	
	Post (N=63)						4.2
I would rather agree with other people than do an experiment to find out for myself.	<u>Treatment</u>						
	Pre (N=95)						
	Post (N=75)	3.5	45.3	16.8	4.2	3.2	2.0
		26.7	49.3	17.3	6.7	.0	2.0
(Q24)	<u>Control</u>						
	Pre (N=88)	27.3	39.8	14.8	9.1	9.1	2.3
	Post (N=63)	23.8	38.1	19.0	14.3	4.8	2.4

I would prefer to do my own experiments than to find out information from a teacher.	<u>Treatment</u>						
	Pre (N=95)						
	Post (N=75)	3.2	7.4	21.1	4.0	28.4	3.8
		1.3	6.7	18.7	4.0	33.3	4.0
(Q31)	<u>Control</u>						
	Pre (N=88)	2.3	8.0	23.9	31.8	34.1	3.9
	Post (N=63)	3.2	12.7	14.3	42.9	27.0	3.8
I would rather find out things by asking an expert than by doing an experiment.	<u>Treatment</u>						
	Pre (N=95)	15.8	51.6	24.4	6.3	2.1	2.3
	Post (N=75)	17.3	52.0	18.7	1.7	1.3	2.3
(Q38)	<u>Control</u>						
	Pre (N=88)	22.7	22.7	3.7	14.8	9.1	2.7
	Post (N=63)	17.5	46.0	14.3	12.7	9.5	2.5
I would rather solve a problem by doing an experiment than be told the	<u>Treatment</u>						
	Pre (N=95)	1.1	5.3	15.8	33.7	44.2	4.2
	Post (N=75)	.0	8.0	12.0	5.7	29.3	4.0

answer.

(Q45)	<u>Control</u>						
	Pre (N=88)	3.4	8.0	2.5	35.2	33.0	3.9
	Post (N=63)	4.8	6.3	17.5	42.9	28.6	3.8
It is better to ask a teacher the answer than to find it out by doing experiments.	<u>Treatment</u>						
	Pre (N=95)						
	Post (N=75)	34.7	46.3	17.9	.0	1.1	1.9
		22.7	5.7	2.0	5.3	1.3	2.1
(Q52)	<u>Control</u>						
	Pre (N=88)	26.1	36.4	26.1	9.1	2.3	2.3
	Post (N=63)	19.0	41.3	27.0	11.1	1.6	2.4
I would prefer to do an experiment on a topic than to read about it in science magazines.	<u>Treatment</u>						
	Pre (N=95)						
	Post (N=75)	1.1	4.2	23.2	34.7	36.8	4.0
		2.7	5.3	16.0	5.7	25.3	3.9
(Q59)	<u>Control</u>						
	Pre (N=88)	2.3	5.7	26.1	39.8	26.1	3.8

	Post (N=63)	3.2	9.5	17.5	39.7	3.2	3.8
It is better to be told scientific facts than to find them out from experiments.  (Q66)	<u>Treatment</u>						
	Pre (N=95)	3.5	45.3	18.9	4.2	1.1	2.2
	Post (N=75)	22.7	5.7	17.3	6.7	2.7	2.2
	<u>Control</u>						
	Pre (N=88)	25.0	45.5	2.5	3.4	5.7	2.45
	Post (N=63)	17.5	54.0	19.0	7.9	1.6	2.22

#### Test of the Homogeneity-of-Slopes Assumption

Source	Type III Sum of Squares	df	Mean Square	F	Sig.	Partial $\eta$ Squared
Corrected Model	2315.86	3	771.96	23.18	.00	.34
Intercept	533.31	1	533.31	16.01	.00	.11
PreI	2229.89	1	2229.89	66.94	.00	.33
BalloonSat	1.16	1	1.16	.31	.58	.00
BalloonSat*PreI	11.30	1	11.30	.34	.56	.00
Error	4463.51	134	33.31			



Total	215509.00	138
Corrected Total	6779.37	137

**Test of the Main Effect and the Covariate for the One-Way ANOVA**

Source	Type III Sum of Squares	df	Mean Square	F	Sig.	Partial $\eta$ Squared
Corrected Model	2304.56	2	1152.28	34.76	.00	.34
Intercept	55.76	1	55.76	16.62	.00	.11
PreI	2218.91	1	2218.91	66.94	.00	.33
BalloonSat	.73	1	.73	.02	.88	.00
Error	4478.81	135	33.15			
Total	215509.00	138				
Corrected Total	6779.37	137				

**APPENDIX L**

**Results for Primary Research Question #4**

**Responses from TOSRA Survey**

<b>Question #</b>	<b>N</b>	<b>Strongly Disagree</b>	<b>Disagree</b>	<b>Not Sure</b>	<b>Agree</b>	<b>Strongly Agree</b>	<b>Mean</b>
		<b>%</b>	<b>%</b>	<b>%</b>	<b>%</b>	<b>%</b>	
I enjoy reading about things that disagree with my previous ideas.	<u>Treatment</u>						
	Pre (N=95)						
	Post (N=75)	6.3	7.4	37.9	41.1	7.4	3.4
		5.3	12.0	36.0	37.3	9.3	3.3
(Q4)	<u>Control</u>						
	Pre (N=88)	9.1	11.4	36.4	33.0	1.2	3.2
	Post (N=63)	3.2	28.6	28.6	3.2	9.5	3.1
I dislike repeating experiments to check that I get the same results.	<u>Treatment</u>						
	Pre (N=95)	14.7	37.9	25.3	16.8	5.3	2.6
	Post (N=75)	1.7	36.0	21.3	28.0	4.0	2.8

(Q11)	<u>Control</u>						
	Pre (N=88)	1.2	29.5	17.0	3.7	12.5	3.1
	Post (N=63)	7.9	3.2	15.9	34.9	11.1	3.1
I am curious about the world in which we live.	<u>Treatment</u>						
	Pre (N=95)	.0	3.2	14.7	37.9	44.2	4.2
	Post (N=75)	1.3	2.7	2.7	5.7	42.7	4.3
(Q18)	<u>Control</u>						
	Pre (N=88)	2.3	1.1	17.0	43.2	36.4	4.1
	Post (N=63)	1.6	1.6	11.1	5.8	34.9	4.2
Finding out about new things is unimportant.	<u>Treatment</u>						
	Pre (N=95)	62.1	29.5	2.1	3.2	3.2	1.6
	Post (N=75)	49.3	37.3	4.0	5.3	4.0	1.8
(Q25)	<u>Control</u>						
	Pre (N=88)	59.1	23.9	11.4	2.3	3.4	1.7
	Post (N=63)	52.4	28.6	11.1	3.2	4.8	1.8
I like to listen to people whose opinions are different from	<u>Treatment</u>						
	Pre (N=95)	3.2	5.3	33.7	32.6	25.3	3.7

mine.	Post (N=75)	1.3	1.7	2.0	56.0	12.0	3.7
(Q32)	<u>Control</u>						
	Pre (N=88)	5.7	2.3	22.7	47.7	21.6	3.8
	Post (N=63)	3.2	2.6	22.2	36.5	17.5	3.4
I find it boring to	<u>Treatment</u>						
hear about new	Pre (N=95)	4.0	36.8	2.0	2.1	1.1	1.9
ideas.	Post (N=75)	24.0	6.0	13.3	1.3	1.3	2.0
(Q39)	<u>Control</u>						
	Pre (N=88)	34.1	44.3	17.0	2.3	2.3	1.9
	Post (N=63)	33.3	36.5	22.2	6.3	1.6	2.0
In science	<u>Treatment</u>						
experiments, I	Pre (N=95)						
like to use new	Post (N=75)	.0	5.3	28.4	4.0	26.3	3.9
methods which I		1.3	8.0	16.0	58.7	16.0	3.8
have not used							
before.							
(Q46)	<u>Control</u>						
	Pre (N=88)	3.4	6.8	27.3	37.5	25.0	3.7
	Post (N=63)	.0	7.9	22.2	49.2	2.6	3.8

I am unwilling to change my ideas when evidence shows that the ideas are poor.	<u>Treatment</u>						
	Pre (N=95)	22.1	35.8	3.5	9.5	2.1	2.3
	Post (N=75)	17.3	5.7	18.7	8.0	5.3	2.3
	(Q53)						
	<u>Control</u>						
	Pre (N=88)	25.0	33.0	25.0	11.4	5.7	2.4
	Post (N=63)	19.0	3.2	33.3	11.1	6.3	2.6
In science experiments, I report unexpected results as well as expected ones.	<u>Treatment</u>						
	Pre (N=95)	.0	4.2	27.4	41.1	27.4	3.9
	Post (N=75)	4.0	4.0	12.0	64.0	16.0	3.8
	(Q60)						
	<u>Control</u>						
	Pre (N=88)	2.3	2.3	34.1	38.6	22.7	3.8
	Post (N=63)	.0	1.6	25.4	46.0	27.0	4.0
I dislike other peoples' opinions.	<u>Treatment</u>						
	Pre (N=95)	3.5	45.3	18.9	4.2	1.1	2.0
	Post (N=75)	12.0	6.0	18.7	5.3	4.0	2.3
	(Q67)						
	<u>Control</u>						

Pre (N=88)	25.0	45.5	2.5	3.4	5.7	2.2
Post (N=63)	17.5	46.0	27.0	9.5	.0	2.3

**Test of the Homogeneity-of-Slopes Assumption**

<b>Source</b>	<b>Type III Sum of Squares</b>	<b>df</b>	<b>Mean Square</b>	<b>F</b>	<b>Sig.</b>	<b>Partial <math>\eta</math> Squared</b>
Corrected Model	676.61	3	225.54	11.96	.00	.21
Intercept	1294.47	1	1294.47	68.63	.00	.34
PreA	632.31	1	632.31	33.53	.00	.20
BalloonSat	53.06	1	53.06	2.81	.10	.02
BalloonSat*PreA	58.74	1	58.74	3.11	.08	.02
Error	2527.35	134	18.86			
Total	195396.00	138				
Corrected Total	3203.97	137				

**Test of the Main Effect and the Covariate for the One-Way ANOVA**

<b>Source</b>	<b>Type III Sum of Squares</b>	<b>df</b>	<b>Mean Square</b>	<b>F</b>	<b>Sig.</b>	<b>Partial <math>\eta</math> Squared</b>
Corrected Model	617.88	2	308.94	16.13	.00	.19
Intercept	1501.23	1	1501.23	78.37	.00	.37
PreA	579.85	1	579.85	30.27	.00	.18
BalloonSat	4.56	1	4.56	.24	.63	.00
Error	2586.09	135	19.16			
Total	195396.00	138				
Corrected Total	3203.97	137				

**APPENDIX M**

**Results for Primary Research Question #5**

**Responses from TOSRA Survey**

<b>Question #</b>	<b>N</b>	<b>Strongly Disagree</b> %	<b>Disagree</b> %	<b>Not Sure</b> %	<b>Agree</b> %	<b>Strongly Agree</b> %	<b>Mean</b>
Science lessons are fun.	<u>Treatment</u>						
	Pre (N=95)	1.1	5.3	27.4	38.9	27.4	3.9
	Post (N=75)	1.3	5.3	14.7	5.7	28.0	4.0
(Q5)	<u>Control</u>						
	Pre (N=88)	3.4	13.6	25.0	36.4	21.6	3.6
	Post (N=63)	6.3	17.5	17.5	36.5	22.2	3.5
I dislike science lessons.	<u>Treatment</u>						
	Pre (N=95)	29.5	42.1	16.8	1.5	1.1	2.1
	Post (N=75)	6.3	17.5	17.5	36.5	22.2	2.1
(Q12)	<u>Control</u>						
	Pre (N=88)	22.7	39.8	17.0	1.2	1.2	2.5
	Post (N=63)	26.7	48.0	18.7	4.0	2.7	2.6



School should have more science lessons each week.	<u>Treatment</u>						
	Pre (N=95)	4.2	15.8	42.1	25.3	12.6	3.3
	Post (N=75)	1.3	12.0	42.7	3.7	13.3	3.4
(Q19)	<u>Control</u>						
	Pre (N=88)	28.6	2.6	23.8	17.5	9.5	3.1
	Post (N=63)	9.5	3.2	31.7	14.3	14.3	2.9
Science lessons bore me.	<u>Treatment</u>						
	Pre (N=95)	3.5	31.6	28.4	7.4	2.1	2.2
	Post (N=75)	2.0	48.0	16.0	12.0	4.0	2.3
(Q26)	<u>Control</u>						
	Pre (N=88)	22.7	27.3	22.7	21.6	5.7	2.6
	Post (N=63)	19.0	31.7	14.3	22.2	12.7	2.8
Science is one of the most interesting school subjects.	<u>Treatment</u>						
	Pre (N=95)	1.1	11.6	29.5	33.7	24.2	3.7
	Post (N=75)	2.7	9.3	17.3	48.0	22.7	3.8
(Q33)	<u>Control</u>						
	Pre (N=88)	8.0	19.3	17.0	3.7	24.2	3.5
	Post (N=63)	7.9	3.2	7.9	31.7	22.2	3.3

Science lessons are a waste of time.	<u>Treatment</u>						
	Pre (N=95)	36.8	44.2	16.8	1.1	1.1	1.9
	Post (N=75)	3.7	6.0	6.7	2.7	.0	1.8
(Q40)	<u>Control</u>						
	Pre (N=88)	34.1	44.3	15.9	2.3	3.4	2.0
	Post (N=63)	28.6	49.2	12.7	7.9	1.6	2.0
I really enjoy going to science lessons.	<u>Treatment</u>						
	Pre (N=95)	2.1	13.7	33.7	33.7	16.8	3.5
	Post (N=75)	2.7	9.3	25.3	22.2	22.2	3.6
(Q47)	<u>Control</u>						
	Pre (N=88)	9.1	19.3	33.0	25.0	13.6	3.2
	Post (N=63)	9.5	2.6	25.4	22.2	22.2	3.3
The material covered in science lessons is uninteresting.	<u>Treatment</u>						
	Pre (N=95)	23.2	43.2	26.3	5.3	2.1	2.2
	Post (N=75)	22.7	38.7	3.7	6.7	1.3	2.3
(Q54)	<u>Control</u>						
	Pre (N=88)	18.2	43.2	26.1	8.0	4.5	2.4
	Post (N=63)	11.1	5.8	2.6	12.7	4.8	2.5

I look forward to science lessons.	<u>Treatment</u>						
	Pre (N=95)	1.1	7.4	38.9	34.7	17.9	3.6
	Post (N=75)	2.7	8.0	32.0	45.3	12.0	3.6
(Q61)	<u>Control</u>						
	Pre (N=88)	9.1	2.5	27.3	3.7	12.5	3.2
	Post (N=63)	9.5	2.6	22.2	28.6	19.0	3.3
I would enjoy school more if there were no science lessons.	<u>Treatment</u>						
	Pre (N=95)	42.1	25.3	29.5	2.1	1.1	2.0
	Post (N=75)	26.7	42.7	22.7	6.7	1.3	2.1
(Q68)	<u>Control</u>						
	Pre (N=88)	25.0	38.6	17.0	8.0	11.4	2.4
	Post (N=63)	3.2	25.4	15.9	23.8	4.8	2.5

#### Test of the Homogeneity-of-Slopes Assumption

Source	Type III Sum of Squares	df	Mean Square	F	Sig.	Partial $\eta$ Squared
Corrected Model	5159.46	3	1719.82	41.75	.00	.48
Intercept	622.86	1	622.85	15.12	.00	.10

PreE	4489.66	1	4489.66	109.00	.00	.45
BalloonSat	1.05	1	1.05	.03	.87	.00
BalloonSat*PreE	.00	1	.00	.00	1.00	.00
Error	5519.47	134	41.19			
Total	189743.00	138				
Corrected Total	10678.94	137				

**Test of the Main Effect and the Covariate for the One-Way ANOVA**

<b>Source</b>	<b>Type III Sum of Squares</b>	<b>df</b>	<b>Mean Square</b>	<b>F</b>	<b>Sig.</b>	<b>Partial <math>\eta</math> Squared</b>
Corrected Model	5159.46	2	2579.73	63.10	.00	.48
Intercept	657.47	1	657.47	16.08	.00	.11
PreE	4639.96	1	4639.96	113.49	.00	.46
BalloonSat	19.89	1	19.89	.49	.49	.00
Error	5519.47	135	40.89			
Total	189743.00	138				
Corrected Total	10678.94	137				

**APPENDIX N**

**Results for Primary Research Question #6**

**Responses from TOSRA Survey**

<b>Question #</b>	<b>N</b>	<b>Strongly Disagree %</b>	<b>Disagree %</b>	<b>Not Sure %</b>	<b>Agree %</b>	<b>Strongly Agree %</b>	<b>Mean</b>	
I would like to belong to a science club.  (Q6)	<u>Treatment</u>							
	Pre (N=95)	4.2	22.1	32.6	24.2	16.8	3.3	
	Post (N=75)	4.0	9.3	46.7	22.7	17.3	3.4	
	<u>Control</u>							
	Pre (N=88)	12.5	28.4	33.0	15.9	1.2	2.8	
	Post (N=63)	19.0	28.6	27.0	14.3	11.1	2.7	
I get bored when watching science programs on TV at home.  (Q13)	<u>Treatment</u>							
	Pre (N=95)	24.2	24.2	3.5	16.8	4.2	2.5	
	Post (N=75)	22.7	37.3	24.0	14.7	1.3	2.4	
	<u>Control</u>							
	Pre (N=88)	19.3	22.7	28.4	15.9	13.6	2.8	
	Post (N=63)	15.9	27.0	22.2	27.0	7.9	2.8	

I would like to be given a science book or a piece of science equipment as a present.	<u>Treatment</u>						
	Pre (N=95)	17.9	2.0	34.7	2.0	7.4	2.8
	Post (N=75)	9.3	2.0	38.7	22.7	9.3	3.0
	(Q20)	<u>Control</u>					
	Pre (N=88)	26.1	35.2	22.7	1.2	5.7	2.3
	Post (N=63)	27.0	31.7	15.9	17.5	7.9	2.5
I dislike reading books about science during my holidays.	<u>Treatment</u>						
	Pre (N=95)	11.6	2.0	27.4	24.2	16.8	3.2
	Post (N=75)	6.8	24.3	24.3	33.8	1.8	3.2
	(Q27)	<u>Control</u>					
	Pre (N=88)	11.4	12.5	2.5	29.5	26.1	3.5
	Post (N=63)	4.8	14.3	11.1	42.9	27.0	3.7
I would like to do science experiments at home.	<u>Treatment</u>						
	Pre (N=95)	3.2	14.7	24.2	28.4	29.5	3.7
	Post (N=75)	2.7	9.3	17.3	56.0	14.7	3.7
	(Q34)	<u>Control</u>					

	Pre (N=88)	11.4	18.2	25.0	26.1	19.3	3.2
	Post (N=63)	11.1	23.8	2.6	3.2	14.3	3.1
Talking to my friends about science after school would be boring.	<u>Treatment</u>						
	Pre (N=95)	12.6	29.5	27.4	24.2	6.3	2.8
	Post (N=75)	12.0	34.7	3.7	17.3	5.3	2.7
(Q41)	<u>Control</u>						
	Pre (N=88)	4.5	21.6	36.4	19.3	18.2	3.3
	Post (N=63)	1.6	23.8	3.2	3.2	14.3	3.3
I would enjoy having a job in a science laboratory during my school holidays.	<u>Treatment</u>						
	Pre (N=95)	12.6	3.5	32.6	11.6	12.6	2.8
	Post (N=75)	1.7	29.3	34.7	22.7	2.7	2.6
(Q48)	<u>Control</u>						
	Pre (N=88)	23.9	34.1	26.1	1.2	5.7	2.4
	Post (N=63)	2.6	42.9	14.3	15.9	6.3	2.4
Listening to talk about science on	<u>Treatment</u>						

the radio would be boring.	Pre (N=95)	5.3	2.0	41.1	23.2	1.5	3.1
	Post (N=75)	8.0	18.7	4.0	21.3	12.0	3.1
(Q55)	<u>Control</u>						
	Pre (N=88)	9.1	19.3	21.6	31.8	18.2	3.3
	Post (N=63)	3.2	19.0	17.5	34.9	25.4	3.6
I would enjoy visiting a science museum on the weekend.	<u>Treatment</u>						
	Pre (N=95)	5.3	12.6	23.2	32.6	26.3	3.6
	Post (N=75)	.0	9.3	17.3	49.3	24.0	3.9
(Q62)	<u>Control</u>						
	Pre (N=88)	15.9	15.9	18.2	38.6	11.4	3.1
	Post (N=63)	14.3	19.0	25.4	23.8	17.5	3.1
I dislike reading newspaper articles about science.	<u>Treatment</u>						
	Pre (N=95)	13.7	28.4	34.7	18.9	4.2	2.7
	Post (N=75)	12.0	3.7	37.3	17.3	2.7	2.7
(Q69)	<u>Control</u>						
	Pre (N=88)	9.1	28.4	25.0	25.0	12.5	3.0
	Post (N=63)	7.9	33.3	22.2	3.2	2.7	2.9



**Test of the Homogeneity-of-Slopes Assumption**

<b>Source</b>	<b>Type III Sum of Squares</b>	<b>df</b>	<b>Mean Square</b>	<b>F</b>	<b>Sig.</b>	<b>Partial <math>\eta</math> Squared</b>
Corrected Model	4953.28	3	1651.09	47.88	.00	
Intercept	901.34	1	901.34	26.14	.00	
PreL	3938.20	1	3938.20	114.21	.00	
BalloonSat	.04	1	.04	.00	.97	
BalloonSat*PreL	11.81	1	11.81	.34	.56	
Error	462.61	134	34.48			
Total	136792.00	138				
Corrected Total	9573.88	137				

**Test of the Main Effect and the Covariate for the One-Way ANOVA**

<b>Source</b>	<b>Type III Sum of Squares</b>	<b>df</b>	<b>Mean Square</b>	<b>F</b>	<b>Sig.</b>	<b>Partial <math>\eta</math> Squared</b>
Corrected Model	4941.47	2	2470.73	72.00	.00	.52
Intercept	979.24	1	979.24	28.54	.00	.18
PreL	3943.76	1	3943.76	114.93	.00	.46
BalloonSat	134.16	1	134.16	3.91	.05	.03

Error	4632.42	135	34.31
Total	136792.00	138	
Corrected Total	9573.88	137	

**APPENDIX O**

**Results for Primary Research Question #7**

**Responses from TOSRA Survey**

<b>Question #</b>	<b>N</b>	<b>Strongly Disagree %</b>	<b>Disagree %</b>	<b>Not Sure %</b>	<b>Agree %</b>	<b>Strongly Agree %</b>	<b>Mean</b>
I would dislike being a scientist after I leave school.  (Q7)	<u>Treatment</u>						
	Pre (N=95)	17.9	33.7	33.7	12.6	2.1	2.5
	Post (N=75)	1.7	26.7	45.3	13.3	4.0	2.7
	<u>Control</u>						
	Pre (N=88)	6.8	21.6	36.4	21.6	13.6	3.1
	Post (N=63)	6.3	9.5	47.6	2.6	15.9	3.3
When I leave school, I would like to work with people who make discoveries in science.  (Q14)	<u>Treatment</u>						
	Pre (N=95)	1.1	12.6	43.2	28.4	1.2	3.4
	Post (N=75)	1.3	8.0	42.7	37.3	1.7	3.5
	<u>Control</u>						

	Pre (N=88)	6.8	13.6	4.9	28.4	1.2	3.2
	Post (N=63)	6.3	15.9	39.7	22.2	15.9	3.3
I would dislike a	<u>Treatment</u>						
job in a science	Pre (N=95)	2.0	3.5	37.9	9.5	2.1	2.4
laboratory after I	Post (N=75)	1.7	4.0	3.7	16.0	2.7	2.6
leave school.							
(Q21)	<u>Control</u>						
	Pre (N=88)	8.0	17.0	43.2	21.6	1.2	3.1
	Post (N=63)	9.5	14.3	39.7	27.0	9.5	3.1
Working in a	<u>Treatment</u>						
science	Pre (N=95)	.0	6.3	27.4	48.4	17.9	3.8
laboratory would	Post (N=75)	1.3	6.7	21.3	53.3	17.3	3.8
be an interesting							
way to earn a							
living.							
(Q28)	<u>Control</u>						
	Pre (N=88)	4.5	11.4	36.4	35.2	12.5	3.3
	Post (N=63)	4.8	7.9	34.9	34.9	17.5	3.5
A career in	<u>Treatment</u>						
science would be	Pre (N=95)	32.6	36.8	27.4	2.1	1.1	2.0
dull and boring.							

	Post (N=75)	22.7	42.7	3.7	4.0	.0	2.2
(Q35)	<u>Control</u>						
	Pre (N=88)	2.5	38.6	28.4	9.1	3.4	2.4
	Post (N=63)	22.2	27.0	34.9	12.7	3.2	2.5
I would like to	<u>Treatment</u>						
teach science	Pre (N=95)	14.7	22.1	45.3	13.7	4.2	2.7
when I leave	Post (N=75)	13.3	28.0	38.7	17.3	2.7	2.7
school.							
(Q42)	<u>Control</u>						
	Pre (N=88)	25.0	3.7	35.2	5.7	3.4	2.3
	Post (N=63)	17.5	39.7	34.9	6.3	1.6	2.4
A job as a	<u>Treatment</u>						
scientist would	Pre (N=95)	29.5	32.6	31.6	4.2	2.1	2.2
be boring.	Post (N=75)	24.0	3.7	37.3	8.0	.0	2.3
(Q49)	<u>Control</u>						
	Pre (N=88)	18.2	3.7	29.5	14.8	6.8	2.6
	Post (N=63)	17.5	25.4	38.1	9.5	9.5	2.7
A job as a	<u>Treatment</u>						
scientist would	Pre (N=95)	1.1	7.4	22.1	45.3	24.2	3.8

be interesting.	Post (N=75)	.0	4.0	21.3	53.3	21.3	3.9
(Q56)	<u>Control</u>						
	Pre (N=88)	5.7	1.2	29.5	38.6	15.9	3.5
	Post (N=63)	9.5	11.1	39.7	22.2	17.5	3.3
I would dislike	<u>Treatment</u>						
becoming a	Pre (N=95)	24.2	35.8	28.4	8.4	3.2	2.3
scientist because	Post (N=75)	13.3	5.7	29.3	4.0	2.7	2.3
it needs too much							
education.							
(Q63)	<u>Control</u>						
	Pre (N=88)	8.0	28.4	43.2	12.5	8.0	2.8
	Post (N=63)	12.7	2.6	33.3	27.0	6.3	2.9
I would like to be	<u>Treatment</u>						
a scientist when I	Pre (N=95)	5.3	15.8	52.6	15.8	1.5	3.1
leave school.	Post (N=75)	8.0	17.3	46.7	18.7	9.3	3.0
(Q70)	<u>Control</u>						
	Pre (N=88)	14.8	18.2	46.6	15.9	4.5	2.8
	Post (N=63)	15.9	27.0	39.7	11.1	6.3	2.7

**Test of the Homogeneity-of-Slopes Assumption**

<b>Source</b>	<b>Type III Sum of Squares</b>	<b>df</b>	<b>Mean Square</b>	<b>F</b>	<b>Sig.</b>	<b>Partial <math>\eta</math> Squared</b>
Corrected Model	3641.89	3	1213.97	45.29	.00	.50
Intercept	572.61	1	572.61	21.36	.00	.14
PreC	2963.40	1	2963.40	11.55	.00	.45
BalloonSat	.00	1	.00	.00	.99	.00
BalloonSat*PreC	.80	1	.80	.03	.86	.00
Error	3591.92	134	26.81			
Total	156133.00	138				
Corrected Total	7233.80	137				

**Test of the Main Effect and the Covariate for the One-Way ANOVA**

<b>Source</b>	<b>Type III Sum of Squares</b>	<b>df</b>	<b>Mean Square</b>	<b>F</b>	<b>Sig.</b>	<b>Partial <math>\eta</math> Squared</b>
Corrected Model	3641.09	2	1820.55	68.41	.00	.50
Intercept	610.96	1	610.96	22.96	.00	.15
PreC	3015.00	1	3015.00	113.29	.00	.46
BalloonSat	19.32	1	19.32	.73	.40	.01

Error	3592.71	135	26.61
Total	156133.00	138	
Corrected Total	7233.80	137	



## APPENDIX P

### Results of Test for Gender Interaction

#### TOSRA Scale S Test of the Homogeneity-of-Slopes Assumption

Source	Type III Sum of Squares	df	Mean Square	F	Sig.
Corrected Model	894.96	4	223.74	10.71	.00
Intercept	1099.84	1	1099.84	52.67	.00
PreS	791.35	1	791.35	37.89	.00
BalloonSat	3.03	1	3.03	.15	.70
Gender	39.25	1	39.25	1.88	.17
BalloonSat*Gender	1.478	1	1.48	.07	.79
Error	2777.53	133	20.88		
Total	215290.00	138			
Corrected Total	3672.49	137			

**TOSRA Scale N Test of the Homogeneity-of-Slopes Assumption**

<b>Source</b>	<b>Type III Sum of Squares</b>	<b>df</b>	<b>Mean Square</b>	<b>F</b>	<b>Sig.</b>
Corrected Model	1193.30	4	298.33	15.86	.00
Intercept	417.40	1	417.40	22.19	.00
PreN	1025.95	1	1025.95	54.54	.00
BalloonSat	13.24	1	13.24	.70	.40
Gender	26.46	1	26.46	1.41	.24
BalloonSat*Gender	49.00	1	49.00	2.61	.11
Error	2501.69	133	18.81		
Total	192543.00	138			
Corrected Total	3694.99	137			

**TOSRA Scale I Test of the Homogeneity-of-Slopes Assumption**

<b>Source</b>	<b>Type III Sum of Squares</b>	<b>df</b>	<b>Mean Square</b>	<b>F</b>	<b>Sig.</b>
Corrected Model	2410.11	4	602.53	18.34	.00
Intercept	617.04	1	617.04	18.78	.00
PreI	1999.48	1	1999.48	60.86	.00
BalloonSat	.82	1	.82	.03	.88
Gender	102.53	1	102.53	3.12	.08
BalloonSat*Gender	7.00	1	102.53	.21	.65
Error	4369.26	133	7.00		
Total	215509.00	138	32.85		
Corrected Total	6779.37	137			

**TOSRA Scale A Test of the Homogeneity-of-Slopes Assumption**

<b>Source</b>	<b>Type III Sum of Squares</b>	<b>df</b>	<b>Mean Square</b>	<b>F</b>	<b>Sig.</b>
Corrected Model	682.33	4	170.58	9.00	.00
Intercept	1559.97	1	1559.97	82.28	.00
PreA	505.92	1	505.92	26.68	.00
BalloonSat	4.54	1	4.54	.24	.63
Gender	29.75	1	29.75	1.57	.21
BalloonSat*Gender	29.92	1	29.92	1.58	.21
Error	2521.64	133	18.96		
Total	195396.00	138			
Corrected Total	3203.97	137			

**TOSRA Scale E Test of the Homogeneity-of-Slopes Assumption**

<b>Source</b>	<b>Type III Sum of Squares</b>	<b>df</b>	<b>Mean Square</b>	<b>F</b>	<b>Sig.</b>
Corrected Model	5261.27	4	382.95	32.29	.00
Intercept	616.22	1	616.22	15.13	.00
PreE	4682.82	1	4682.82	114.96	.00
BalloonSat	18.98	1	18.98	.47	.50
Gender	.69	1	.69	.02	.90
BalloonSat*Gender	101.80	1	101.80	2.50	.12
Error	5417.66	134	40.73		
Total	189743.00	138			
Corrected Total	10678.94	137			

**TOSRA Scale L Test of the Homogeneity-of-Slopes Assumption**

<b>Source</b>	<b>Type III Sum of Squares</b>	<b>df</b>	<b>Mean Square</b>	<b>F</b>	<b>Sig.</b>
Corrected Model	5008.38	4	1252.10	2.15	.00
Intercept	959.43	1	959.43	23.75	.00
PreL	3963.82	1	3963.82	5.65	.00
BalloonSat	130.12	1	130.12	1.10	.05
Gender	31.91	1	31.91	.93	.34
BalloonSat*Gender	40.70	1	40.70	1.19	.28
Error	4565.50	133	34.33		
Total	136792.00	138			
Corrected Total	9573.88	137			

**TOSRA Scale C Test of the Homogeneity-of-Slopes Assumption**

<b>Source</b>	<b>Type III Sum of Squares</b>	<b>df</b>	<b>Mean Square</b>	<b>F</b>	<b>Sig.</b>
Corrected Model	3704.39	4	926.10	34.90	.00
Intercept	585.75	1	585.75	22.07	.00
PreC	3036.91	1	3036.91	114.44	.00
BalloonSat	17.11	1	17.11	.65	.42
Gender	38.61	1	38.61	1.46	.23
BalloonSat*Gender	30.00	1	30.00	1.13	.29
Error	3529.41	134	26.54		
Total	156133.00	138			
Corrected Total	7233.80	137			

## APPENDIX Q

### BalloonSat Notes and Directions

### BalloonSat Kit Parts List

(6) ½" Styrofoam (6" by 6")

10mm Cellfoam 88 (6" by 6")

5mm Cellfoam 88 (6" by 6")

1" Foam rubber (6" by 6")

3/8" Coroplast (6" by 6")

(4) ¼" diameter Plastic Tube (6" long)

¼" diameter Plastic Tube (8" long)

Roll of colored Tape

IR Filter (four Congo blue and one primary red gels) (1.5" by 1.5")

Polaroid Filter (1.5" by 1.5")

Camera Bolt (¼-20 bolt, 1" long, two washers, Styrene sheet)

White Plastic Lid

#6-32 bolt, two washers, and one nut

Modified Camera with USB cable and CD

Red Yarn (12" long)

PCBs (bag of ten)

Printed Circuit Boards

BalloonSat Flight Computer

Photometer Base



Temperature Sensors

Temperature Array

(3) Easy Plug

Relative Humidity and Temperature

LED Photometer

Electronic Components

(2) IC Socket (8-pin)

PICAXE-08M2 Microcontroller

TLC272 op-amp

(2) Green LED

Red LED

Yellow LED

LM2950 voltage regulator

HHH-4000 relative humidity sensor

22 uF tantalum capacitor

1 uF capacitor

220 pF capacitor

9-volt battery snap

(4) Right-angle header

2 by 4 receptacle

1 by 3 straight header

Relay

680 ohm resistor

(4) 1k ohm resistor

22k ohm resistor

10k ohm resistor

4k7 ohm resistor

1M ohm resistor

1N4001 diode

(4) LM335 temperature sensor

Shorting block

(15 feet) 24 AWG Wire

## Electronics and Soldering Notes

### The Tools You'll Need

While there are literally one hundred tools for soldering, testing, and fixing electronic circuits, you only need a few to make robot. These tools are explained below.

### Safety Glasses

First and foremost, wear safety glasses. They don't have to be expensive, but they need to have some wrap-around to protect your eyes from flying wires and hot splashes of solder. While your skin will heal from nicks and burns, your eyes won't. So get some eye protection.



**Figure 1. Wearing cheap safety glasses is far better than trying to make robots blind**

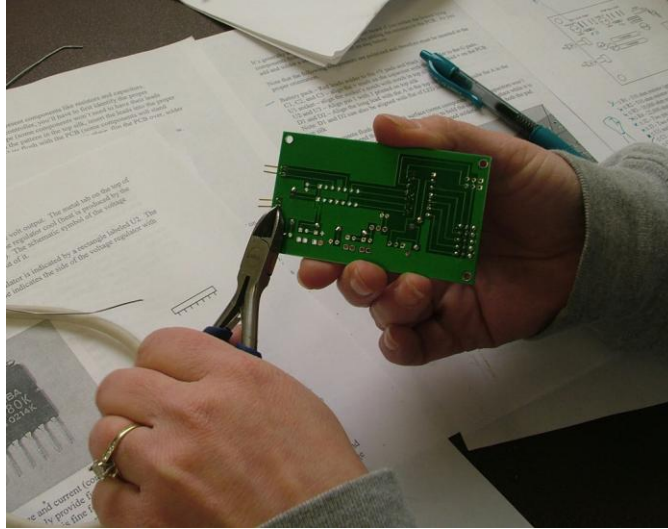
## Wire Cutters



**Figure 2. A small pair of wire cutters lets you clip wires closer to the surface of the robot controller**

Wire cutters cut wire to length and to trim the wires of components sticking out of the robot controller. Get a small pair as large pairs are too big to trim wires (or the leads) of components that have been soldered to the flight computer. Don't use scissors to cut wire and don't try to trim the plastic insulation from wires with a pair of wire cutters.

When wires are cut, they can often fly away in a snap. Therefore, it's important you wear safety glasses when you clip leads and aim the board away from neighbors.



**Figure 3. Be careful when you trim leads. The wires can go flying across the room.**

### **Soldering Iron**



**Figure 4. The soldering iron in its stand and with its sponge. Never lay a hot soldering iron on the table, always use a stand. And always keep the sponge damp.**

The traces on the PCB are 20 mils wide. If too much heat is applied to them, they along with the pads will lift off the PCB. The fastest way to overheat a PCB is to use a soldering gun. Therefore, never use a soldering gun to assemble your flight computer. Instead, use a pencil style

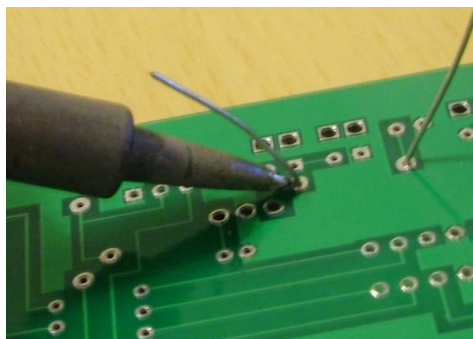
soldering iron. A fine point or narrow chisel point is perfect. If you use a soldering iron with adjustable temperature, then set the temperature at the mid point of its range.

To transfer heat quickly to the work, the tip of the soldering iron needs to be clean and shiny. You can keep the tip clean and free of oxidation by wiping it frequently across the edge of a damp sponge. If the tip of your soldering iron is dark, then it has a coating of oxidized metal on the surface. The oxidized coating prevents heat from transferring quickly to the work and as a result, the entire work area gets hot, including the neighboring traces. Wiping the tip keeps the oxidation at bay. The flux inside your solder can remove stubborn oxide that just wiping can't remove. Apply solder to the soldering iron tip and let the flux break up some of the oxide before wiping it clean.

After wiping the tip clean, apply a thin coat of solder to the tip to block oxygen from attacking the iron tip. Keep the solder coat thin, or else a large blob of molten solder will transfer to the PCB when you tap the tip to the PCB. A thin coating of solder will help transfer heat while a thick coating will transfer excess solder.

By the way, never jab the hot soldering iron into a damp sponge. The tip should be brushed against the edge of the sponge quickly. Exposing the soldering iron to the cold damp sponge too long creates a thermal shock to the iron. It also needlessly cools the tip and you'll have to wait for the tip to get hot enough to solder again.

Apply the tip of thin solder to the soldering iron tip, pad, and lead. As the solder begins to melt, run the end of it around the pad, forming a cone of solder that wicks up the lead. Remove the solder before removing the soldering iron or else the solder will be stuck to the soldered pad.



**Figure 5. Apply the tip of the soldering iron to both the pad and lead before applying solder to the pad and lead**

After the solder cools, clip the lead so it does not stick above the cone of solder around the pad. A well soldered lead will look similar to the image below



**Figure 6. A good solder connection is a bright silvery cone**

### **The Resistor Color Code**

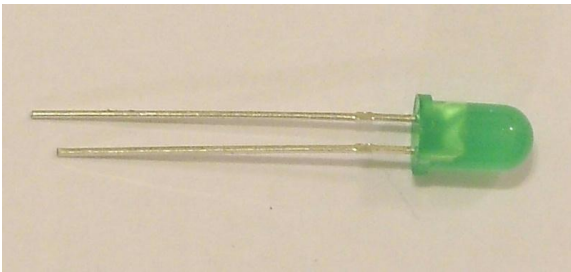
Rather than stamp the value (number of ohms of resistance) of a resistor on its cylindrical body, colored stripes are painted on it. The resistors in the flight computer have four stripes, but there are resistors with five stripes. Each color signifies a single digit between 0 and 9. The colors and the numbers that they represent are shown below.

Black	0
Brown	1
Red	2
Orange	3
Yellow	4
Green	5
Blue	6
Violet	7
Gray	8
White	9

So when you see a green stripe, think the digit 5. Now the way the color code on a resistor works is like this. The first two colored bands are read as digits (gold is the fourth band, so read the colored bands for the end opposite the gold band). Therefore, a Red followed by a Blue is 26. The third colored band is also a digit, but it represents the number of zeros in the resistance of the resistor. Therefore, a Yellow, or 4, in the third band means there are four zeros, or 0000 at the end of the first two numbers. So take for example, a 510  $\Omega$  resistor. Its three important colored bands are Green, Brown, Brown.

The fourth band of the resistors in your flight computer is always gold. That indicates the resistors have a tolerance of 5%, or that the actual resistance can be as much as 5% different than the indicated value.

## LEDs



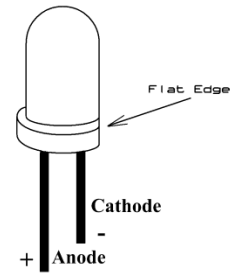
**Figure 7. A light-emitting diode (LED)**

**Schematic of a LED**

Light-emitting diodes are a type of diode that emits light when current flows through them. In this way, they behave like light bulbs, except they will not burn out over the lifetime of the robot controller. To protect LEDs from excessive current, each one is connected to a resistor. LEDs are polarized devices, if they are soldered in backwards they will not operate (but they won't be damaged, either). The negative lead (called the cathode) is usually the shorter of the two leads. A second and surer way to identify the cathode lead is to look for the flattened side of the LED lens (plastic body). The schematic of an LED is the diode symbol (an arrow touching a bar) with one or two arrows pointing away from the diode (to indicate light is shining out of the diode).



The arrow of the schematic points to the negative lead or cathode. The other lead of the LED is called the anode.



The proper placement of the LEDs on the PCB are indicated by a circle with the label D1 and D2. The upper-case A (A) next to the LED circle indicates the pad for the positive lead (anode) of the LED.

**Figure 8. Identifying the two leads of the LED**

### Assembly Directions

Components are inserted on the printed side (top) of the PCB and their leads are soldered on the unprinted side (bottom). Bend the leads of each component to their proper spacing before inserting the leads in the PCB. Most likely, only resistors will need their leads bent, all other components will probably already have the proper lead spacing. Bend both leads at the resistor body to a 90 degree angle as illustrated below.



**Figure 9. Bend resistor leads very close to their bodies**

Insert each component into the PCB at the location reserved for that specific component. The reserved location for each one is printed on the PCB in white letters (top silk) and identified by their number, e.g. R1 for the first resistor and C2 for the second capacitor.

It's generally easier to assemble a printed circuit board if you solder the lowest lying components first. This means you'll begin by adding the resistors to the PCB. As you add and solder a component, check off its step below.

Note that the following components are polarized and therefore must be inserted in the proper orientation.

Battery pack – Red leads solder to the +V pads and black leads solder to the G pads.

C1 – align the + mark on the capacitor with the pad marked + on the PCB

U1 socket – align the socket's notch with notch in top silk

U2 – Align flat side of the voltage regulator with flat edge in top silk

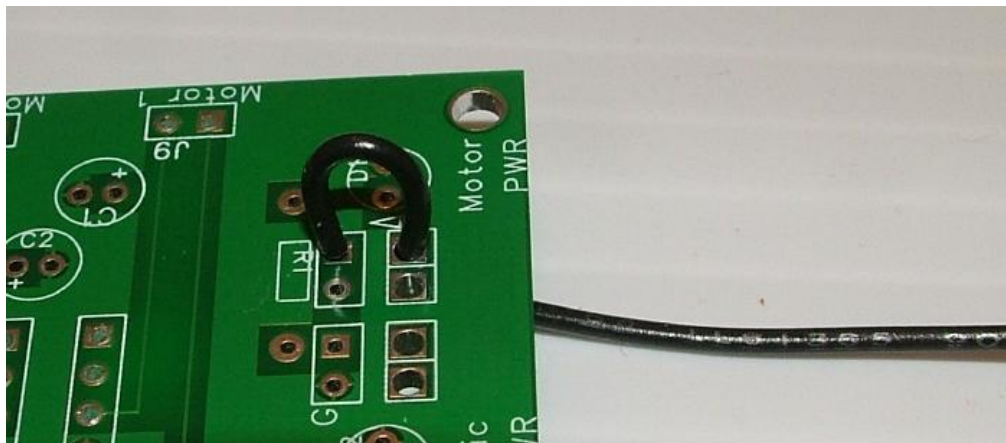
D1 – Align the long lead with the A in the top silk

D2 – Align silver band of the diode with the double line in the top silk

Set components flush with the PCB surface (some components like the capacitors won't fit flush) and bend their leads apart just slightly to hold the component in place while it is being soldered. Flip the PCB over and apply a tinned soldering iron tip to both the pad and lead simultaneously.

### **Strain Relief for Battery Snap**

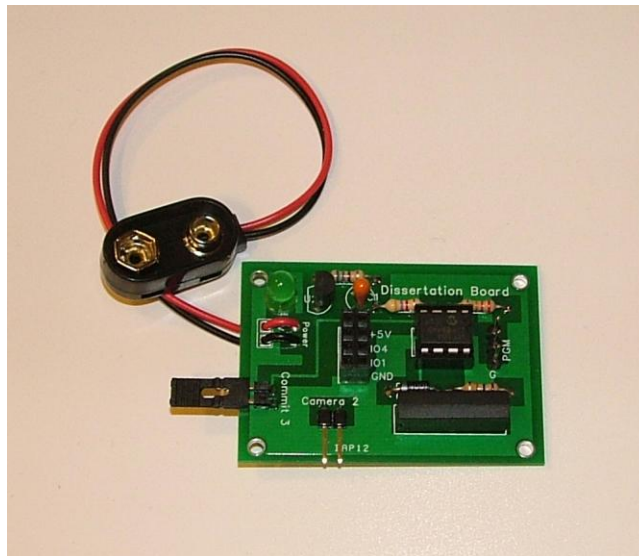
In order that the wires of the 9V battery snap do not break off the flight computer, the wires first pass through large holes in the PCB before they are soldered to the PCB. The wires and their insulation pass through the large holes as shown below.



**Figure 10. A strain relieved wire ready for soldering**

## The Dissertation BalloonSat Flight Computer

There are 21 parts in this BalloonSat flight computer, the heart of which is the PICAXE-08M2. The PICAXE is a microcontroller; making the BalloonSat Flight Computer programmable. The PICAXE-08M2's internal memory is limited to 2 kilobytes (kb), or about 480 lines of code. The PICAXE's BASIC programming language is powerful enough that only a fraction of the memory is required to operate most near space missions. In addition to the 2kb of program memory, there is an additional 256 bytes of data storage memory. All the results from the sensors attached to your BalloonSat are stored in this memory. Power for the flight computer comes from a single nine-volt battery and the weight of the flight computer, including battery, is only 61 grams. That leaves a lot of weight available for the BalloonSat airframe and sensor suite.



**Figure 1. The BalloonSat Programmable Flight Computer.**

### Parts List

On the top of the printed circuit board (PCB) you will find white colored lettering that indicates the placement and orientation of individual electronic components (the lettering is called top silk). Each component has a unique and meaningful reference consisting of a letter followed by a digit. All resistors for example, have a reference beginning with the letter R. Below is a list of the components in the BalloonSat Flight computer kit and their references you'll find on the PCB.

**C1** 22uF tantalum capacitor

**D1** Green (or red) light-emitting diode (T1-3/4)

**D2** 1N4001 diode

**R1** 680 ohm resistor (blue, gray, brown gold or blue, gray, black, black, brown)

**R2** 4k7 ohm resistor (yellow, violet, red, gold or yellow, violet, black, brown, brown)

**R3** 22k ohm resistor (red, red, orange, gold or red, red, black, red, brown)

**R4** 10k ohm resistor (brown, black, orange, gold or brown, black, black, red, brown)

**RL** 5V reed relay

**U1** Eight-pin IC socket

**U2** LM2950 +5 volt regulator (TO-92)

**Note:** Check the flat face of the LP2950 and make sure its says LP2950 and not LM335. The LM335 looks the same, but it's a temperature sensor and not a voltage regulator.

The remaining items are required to complete the BalloonSat Flight computer, but they do not have a reference on the PCB.

PICAXE-08M2

**Note: Make sure the name PICAXE-08M2 is stamped on the IC and that it's not the TLC272 op-amp**

Nine volt battery snap

Two-pin right angle header (2 of these)

Four-pin right angle header

Three-pin straight header

Two by three hole receptacle

Shorting block

Two printed circuit boards (PCBs)

## Component Pictorials

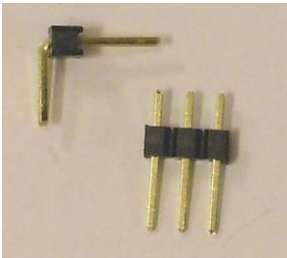
The following pictures illustrate the physical appearance of the components you'll find in the kit. The integrated circuit and its socket are for illustration only; these parts in the BalloonSat Flight computer are smaller and have eight pins.



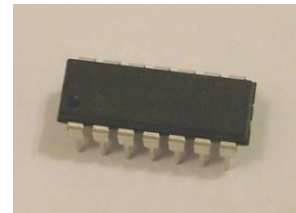
**Figure 2. Capacitor**



**Figure 3. Diode**



**Figure 4. Headers**



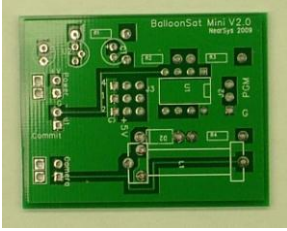
**Figure 5. Integrated  
Circuit (IC)**



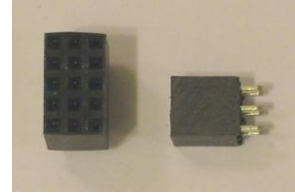
**Figure 6. IC Socket**



**Figure 7. Light-  
emitting diode**



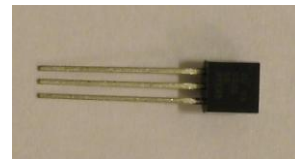
**Figure 8. Printed  
Circuit Board (PCB)**



**Figure 9. Receptacles**



**Figure 10. Resistor**



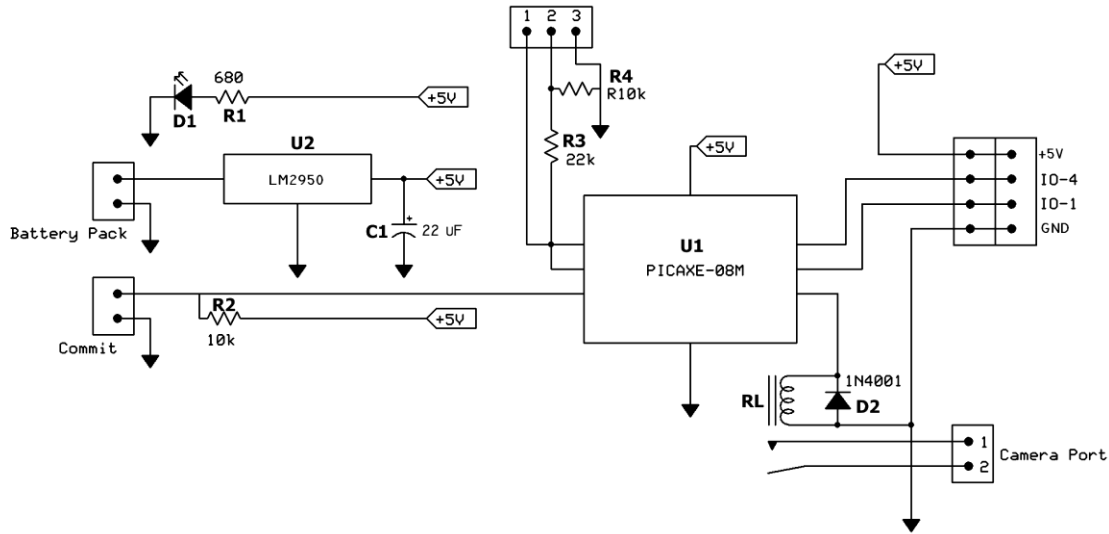
**Figure 11. Voltage  
Regulator**

**Note: Don't confuse the voltage regulator for the temperature sensor. They look alike, but the voltage regulator has the name, LP2950 stamped on its face (the four temperature sensors are stamped with LM335).**



**Figure 12. Shunting Block**

## Theory of Operation



**Figure 13. BalloonSat Flight Computer Schematic**

The arrangement of components in the flight computer is designed to support the PICAXE-08M2 in the process of collecting and storing data. Below is a brief description of each component and how it supports the mission of the BalloonSat flight computer.

The voltage regulator (LM2950) converts the slowly declining voltage of the nine volt transistor battery into a constant five volts that the PICAXE prefers. The 22 uF capacitor next to the voltage regulator acts like a temporary battery that helps the voltage regulator maintain a more constant five volt output. If the voltage surges slightly higher, the capacitor absorbs the excess current; changing it into charge stored on its plates and bringing the voltage back down to five volts. If the voltage drops slightly lower, the capacitor dumps its stored charge; changing it into needed current and pushing the voltage back up to five volts.

The LED's only function is to light up when five volts is present. Therefore, the LED is solely a power indicator (since there are no moving parts, there is no other way to see if the BalloonSat Flight computer is operating). The 680 ohm resistor connected to the LED limits the current flowing through the LED so it and the voltage regulator are protected from excessive current.

The program header is a three straight pin header that connects to a PC so that the PICAXE Editor can download its program into the BalloonSat flight computer. The 22k resistor limits the amount of current flowing between the PC serial port and the PICAXE during the programming process. The 10k resistor is a pull down resistor that ensures then when no programming instructions are flowing between the PC and PICAXE, the PICAXE does not detect false data.

The commit header is a two right angle pin header that sends a five volt signal to I/O #3 of the PICAXE. The five volt signal is created by the 4k7 resistor connected to the voltage regulator. The five volts appears on one of the pins of the header and the other pin in the commit header is connected to ground, or zero volts. When the commit header is shorted with the Commit Pin, current from the pull up resistor bypasses the PICAXE and travels straight to ground. In doing so, the PICAXE sees zero volts in place of the original five volts. The program you will write will monitor when the Commit Pin is removed. Only when the Commit Pin is removed will you let your program begin collecting and storing data. Note that this means the PICAXE can operate for hours on end without recording data until it's signaled to do so by the removal of the Commit Pin.

The input-output (I/O) port provides five volts, ground, and a unique connection to the PICAXE for each experiment plugged into it. The data from sensors can be either a voltage that varies by magnitude in response to a particular environmental condition, a voltage that is either on or off based on conditions, or digital data sending meaningful pulses. The program downloaded into the PICAXE analyzes the output from sensors and records the results for downloading after recovery.

The PICAXE I/O #2 operates the camera relay. The wire coil inside the relay is energized every time the PICAXE is programmed to take a picture. By energizing the coil, a magnetically activated switch inside the relay closes and triggers the camera shutter attached to the BalloonSat Flight computer. When the relay's coil is de-energized, the collapsing magnetic field of the coil induces a backwards flowing current towards the PICAXE. In a large coil this current can be great enough to damage the PICAXE. To prevent this damage, the PICAXE protected from the back current by a diode. By orienting the diode in the proper direction, this back current is safely routed to ground and away from the PICAXE. The relay used in the BalloonSat Flight computer is pretty small, so the diode is probably not needed. However, it's better to be safe than sorry at 100,000 feet. A specially modified camera connects to the two-pin right angle header on the flight computer.

## **Assembly Tools**

You'll need the following tools to assemble the BalloonSat Flight computer (and any other PCB).



## **Soldering Iron**

Use a low wattage, pencil style soldering iron and not a soldering gun. The tip should have a fine point or chisel. A soldering iron with temperature control would be great, but it isn't required to successfully complete the BalloonSat Flight computer. If you use a soldering iron with temperature control, set the temperature to the midpoint.

## **Sponge**

A damp sponge cleans oxide and excess solder from the tip of the soldering iron. Don't poke the sponge with the soldering iron. Instead, quickly wipe the tip of the soldering iron against the edge of the damp sponge. This wipes off the oxide and excess solder, leaving the tip clean. After wiping the tip of the soldering iron clean, apply fresh solder to lightly coat the tip in a protective layer of molten solder. The molten solder helps heat flow from the soldering iron to the work.

## **Solder**

Solder is an alloy, or mix of lead and tin. The alloy has a low melting point, but molten solder is still very hot – so be careful when soldering. Inside the solder is a narrow channel of flux called rosin. The flux melts first and flows out of the solder to coat the work. Flux helps remove oxide and protects the clean surface so the molten solder following the flux will more likely stick to the work. Use a narrow diameter solder, like 0.032 inches to assemble the BalloonSat Flight computer. Under no circumstances use large diameter solder or solder containing an acid flux. The acid flux will eventually corrode the electrical connections within the PCB.

## **Wire Cutters**

Wire cutters trim wires to length. The trimming is performed before and after soldering; before to cut wires for the sensor array and after to trim excess lead length. Be aware that cut leads can fly across the room. Therefore, be safe and hold or cover the excess lead so it can't fly away when it is cut.

## **Wire Strippers**

Wire is insulated with a plastic coating; however, wires cannot be soldered through this coating. So it must be removed without damaging the copper wire. Do not use wire cutters to strip wire as they will nick and weaken the wire. There are several different types of wire strippers to safely strip insulation. If your wire strippers have several diameter holes for stripping wire, then use the #24 gauge hole to strip the wires. In a pinch, the wire in the kit can be stripped as #22 gauge. The

other type of wire strippers are automatic strippers that adjust to the diameter of the wire as they strip the insulation.

## **Sandpaper**

To keep the cost of the BalloonSat low as possible, several components in the kit are purchased in long strips and then cut to their proper size. This includes the receptacles. The cut edges of the receptacle are rough (sorry, I can't shear the receptacles more smoothly), so you should sand them until they look nice. Place a sheet of 120 grit sand paper (or other grit close to 120) on top of a flat surface like a table top. Then briskly wipe the raw edge of the receptacle across the surface of the sandpaper. Watch that you don't sand off too much of the receptacle. The cut edge of the receptacle can be made even smoother by switching the 120 grit sandpaper with a 220 and wiping the cut edge across this sandpaper.

## **Multimeter**

While not strictly required, it's a good idea to have access to a multimeter to test and troubleshoot the BalloonSat Flight computer. The Flight computer's PCB is design so every flight computer should work upon completion. Nevertheless, on occasion, a bad solder connection can crop up or a component can be damaged. Locating these problems is easier with a multimeter.

## **Forming and Soldering**

The particular order that the components are installed is not really important, however, it is recommended that when soldering, you install the lowest lying components first.

Before you insert the first lead of a component into a PCB, form the component by bending its leads to the proper length. Then insert the component on the top silk side of the PCB and flush to the PCB (there are a few exceptions that will be noted in the directions). Then flip over the PCB and solder the leads to the pads. To prevent the component from falling out when the PCB is flipped over, either spread the leads slightly or use a little bit of masking tape to hold the component in place.

A component lead cannot be properly soldered until both the lead and the pad on the PCB are hot. However, if the copper trace or pad on the PCB gets too hot, they will lift off the PCB damaging the circuit. Therefore, the pad and lead must be heated quickly by using a soldering iron tip that is clean of oxidation and damp with a little solder. As you are assembling the flight computer, wipe the tip of the soldering iron on a damp sponge frequently to keep it clean. After cleaning the tip, apply a little bit of fresh solder to it to keep it lightly covered in liquid solder.

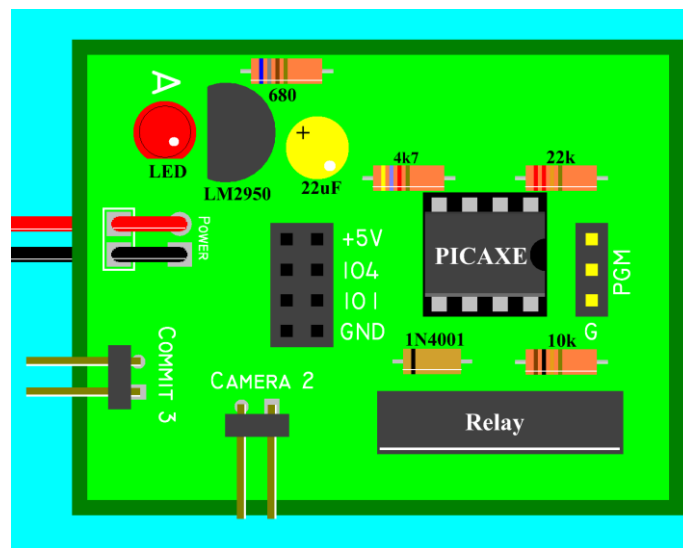
When you are ready to solder, place the tip of the soldering iron where the component lead and pad meet. Then touch the tip of the solder to the iron and pad/lead to melt the solder. Quickly run the solder around the hot pad to create a shallow solder pool over the face of the pad. Then quickly remove the solder followed by the soldering iron.

The solder should form a cone around the pad and up the lead. There should be no major gaps in the solder coverage around the pad or a balling up of the solder. If the soldered connection is nearly good enough then leave it be. Trying to rework a soldered connection to make it absolutely perfect is inviting damage to the PCB.

After the solder cools, cut the excess lead at the top of the solder cone with a pair of wire cutters. Be careful not to cut deeply into the solder cone or else the connection can be damaged.

## Assembling the BalloonSat Flight computer

The diagram below illustrates the placement of the components you will solder to the BalloonSat Flight computer PCB. Follow the diagram and check off each step as you complete it.



**Figure 14. Parts Layout for the BalloonSat Flight computer**

## 1. Resistors

Form (bend) the resistor leads before inserting them into the PCB. Each resistor's position is indicated by its R-number.

- **R1 680 ohms (blue, gray, brown, gold)**
- **R2 4.7 k-ohms (yellow, violet, red, gold)**
- **R3 22 k-ohms (red, red, orange, gold)**
- **R4 10 k-ohms (brown, black, orange, gold)**

## 2. Diode

The diode has its name, 1N4001 printed on it and a white or black stripe painted around one end. Orient the diode's stripe according to the diagram above. If it's backwards, the relay will never trigger the camera and the PICAXE could be damaged.

- **D2 1N4001**

## 3. Commit/Camera Header

Insert the short leads into the PCB and leave the longer pair hanging over the edge of the PCB.

- **2-pin right angle Commit Pin**
- **2-pin right angle Camera Port**

## 4. Cable

Solder the nine volt battery snap and the camera cable to the PCB. Note that there are large diameter holes near the edge of the PCB and smaller holes inside of them. The large holes are the strain relief that will prevent normal usage from breaking the wires off the PCB. Begin with the battery snap since its wires are already stripped. Note that one wire is red and the other is black. The red wire is positive nine volts and the black is ground. These must be soldered to the proper pads in the PCB or the flight computer will not power up. Push each wire up through the strain relief hole from the underside of the PCB and then bend each wire down and into its pad. Push the wires through the pads until their insulation is flush with the PCB and no bare wire is exposed above (or nearly no wire is exposed above). Then solder the wire.

- **Battery Snap**

## 5. IC Socket

To protect the PICAXE from heat damage by the soldering iron, solder the IC socket to the PCB and not the PICAXE itself. Electrically speaking, the orientation of the IC socket doesn't matter. However, still solder the socket with its notch aligned with the notch on the top silk graphic. The notch in the IC socket will then specify the proper orientation of the PICAXE when you install it. If the PICAXE is installed backwards, the BalloonSat Flight computer will not function. **DO NOT install the PICAXE into the socket before soldering the socket to the PCB** – this defeats the purpose of using the socket. Afterwards, do not insert the PICAXE yet, as the BalloonSat Flight computer must be tested first.

- **U1 8-pin IC socket**

## 6. Capacitor

The capacitor is polarized, so look for a plus (+) mark stamped on its body. The plus marks the positive lead. Orient the capacitor according to the diagram above and solder. The capacitor will probably resist being set flush to the PCB, so don't force it.

- **C1 22 microfarads**

## 7. Voltage Regulator

The voltage regulator is polarized, so install it with the flat face of the regulator aligned with its top silk illustration. This is another component that will not sit flush on the PCB, so don't force it. **Note:** Make sure you see that the voltage regulator has LP2950 stamped on its face. The voltage regulator looks identical to the LM335 temperature sensors.

- **U2 LM2940**

## 8. LED

The LED is another polarized component, but unlike the others, if it is placed backwards, the flight computer will still function; it just won't give you a pretty green light to indicate that it's up and running. Look for the flat edge on the LED's plastic lens, which is usually on the side with the short lead. That flat edge indicates the negative lead of the LED, or its cathode (which is usually the short lead). The other lead is the anode and it goes into the pad marked with the letter A. Push the LED down until it is flush with the PCB and then solder.

- **D1 Green LED**

## **9. Relay**

The writing on the side of the relay is the side of the relay closest to the bottom of the PCB (and on the side opposite the PICAXE). The white line drawn on the relay in figure 14 represents the writing on the side of the relay. The relay sits almost flush to the PCB surface (there are small ridges on the bottom of the relay to prevent from sitting flush).

- **RL Reed relay**

## **10. Receptacle**

The receptacle was cut from the longer piece of receptacle. Therefore, sand the face of the receptacle flat with sandpaper to make it look more professional. The orientation of this component is unimportant, just insert it and push it flush to the PCB before soldering its leads.

- **2 by 4 Receptacle**

## **11. Program Header**

Insert the short ends of the header's pins into the PCB and push it until its plastic base sits flush to the PCB.

- **3-pin Straight Pin Header**

## **Checking Your Work**

That completes the assembly of the BalloonSat Flight computer. However, don't plug the PICAXE-08M2 and battery in just yet. That's because if there is an error in the assembly, the flight computer could be damaged when powered up. First perform these five checks.

### **1. Check the Soldering**

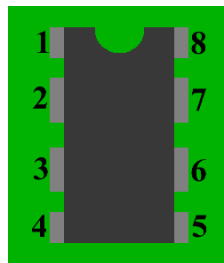
Inspect the underside of the PCB looking for blobs of solder that may bridge across two pads. If there appears to be such a bridge, briefly apply some heat to the pads with your soldering iron and "pull" the molten solder back into two separate cones. Or you could lay solder wick across the solder and try to wick up the excess solder. Do these actions quickly as too much heat can damage copper traces on the PCB.

## 2. Check for Shorts

Set the multimeter to the continuity setting and tap the test leads together. The multimeter will ring or beep to indicate there is a short between the test leads. Now perform the test for real by applying the test leads to the two battery terminal contacts in the nine volt battery snap. There should be no ringing. If there is, then there's a short in the PCB that needs to be located and fixed. Pretty much the only way a short can exist in the PCB is through a solder bridge. So look over the underside of the PCB again, for a solder connection that has overflowed its pad.

## 3. Check the Voltage

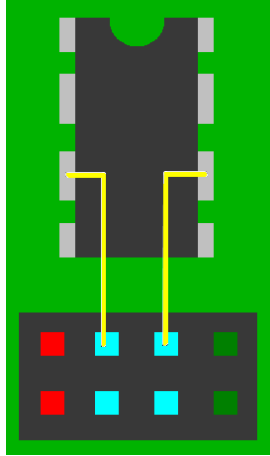
Set the multimeter to measure DC voltage. Snap a nine volt battery into the BalloonSat Flight computer and measure the voltage across pins 1 and 8 of the IC socket. With the red lead on pin 1 and the black lead on pin 8, the multimeter will display a voltage between +4.75 and +5.25 volts.



**Figure 15. IC pin out.**

Check the commit header voltage by leaving the black test lead on pin 8 and moving the read test lead to pin 4. The multimeter will display between +4.75 and +5.25 volts. Next place the shorting block on the commit header and repeat the same measurement. The multimeter will now display close to zero volts.

Check the voltages on the I/O ports. To make an electrical contact with the receptacle, stick cut resistor leads into the openings of the receptacle. The openings in figure 16 are marked in red are +5 volts and in green are ground, or zero volts. So insert one cut resistor lead into a +5 volt opening and a second resistor lead into a ground opening. Tap the test leads of the multimeter to the resistor leads sticking out of the openings and it should display a voltage between +4.75 and +5.25 volts.



**Figure 16. Receptacle connections.**

#### **4. Check I/O Continuity**

The next test is a continuity test. So disconnect the battery and set the multimeter to measure continuity. The yellow lines in figure 16n indicate the connections between the openings in the receptacles and the pins in the PICAXE IC socket. Tap one test lead of the multimeter one pin in the IC socket and use a cut resistor lead to make contact with the appropriate opening in the I/O receptacle. The multimeter should ring for each connection.

#### **5. Check the PICAXE**

Insert a PICAXE-08M2 into the IC socket and plug a serial programming cable into the programming header on the BalloonSat Flight computer.

**Note:** Make sure the name PICAXE-08M2 is stamped on the top of the IC. The TLC272 op-amp looks identical to the PICAXE-08M2.

Start the PICAXE Editor and select the PICAXE-08M2 (the editor programs lots of different types of PICAXE's, so you have to tell it which one). Type the following program and download it into the PICAXE by clicking the Download Button. Figure 17 points to the Download button.

**PAUSE 1000**

**DEBUG**



If the PICAXE has not been damaged and the programming header is properly soldered, the debug window will open and display a single message. There will be a single debug message and circled in figure 17. The debug window will indicate that the PICAXE's memory bytes (B0 to b13) are set to zero.

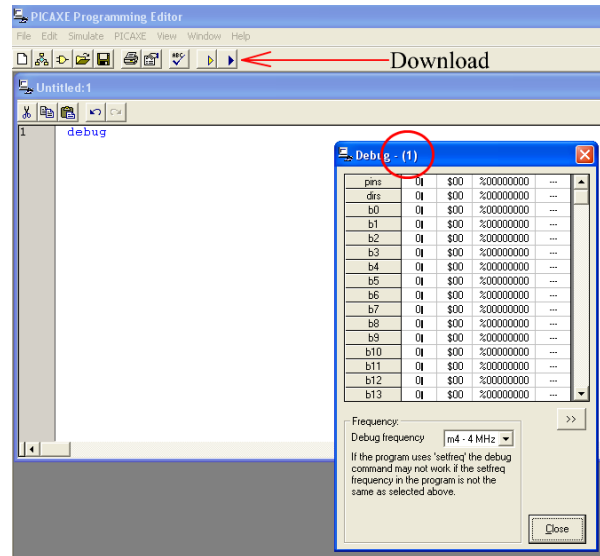


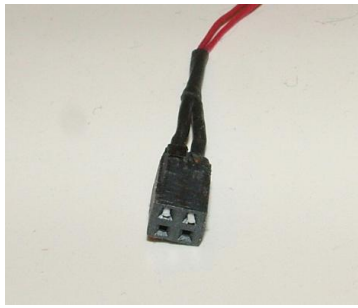
Figure 17. Debug Screen

## Protecting the BalloonSat Flight Computer from Short Circuits

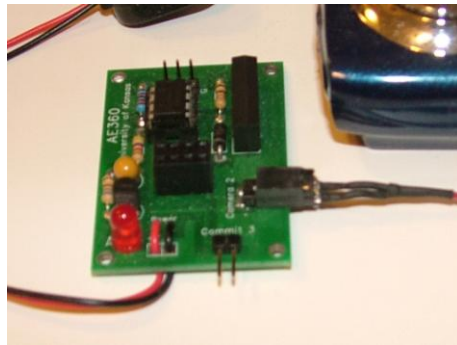
Now that the BalloonSat Flight computer has checked out, it's time to protect the underside from short circuits. As long as the BalloonSat Flight computer is not placed on top of metal, like wires, the flight computer is safe from accidental short circuits. A short circuit occurs when a piece of metal (a conductor of current) bridges the gap between two solder pads that are not connected by a trace. A sheet of Foamcore or foamed neoprene rubber beneath the PCB will prevent short circuits by stray objects.

## Camera Port

The camera cable terminates in a two-by-two receptacle, but notice that two of the holes are filled with a white plastic dowel. That leaves the remaining two holes in the receptacle to connect the camera to the flight computer. Just slide the two open holes in the camera cable to the flight computer's camera port. Note that the camera must be bolted to the BalloonSat airframe using the 1/4 - 20 bolt and washer included in the kit.



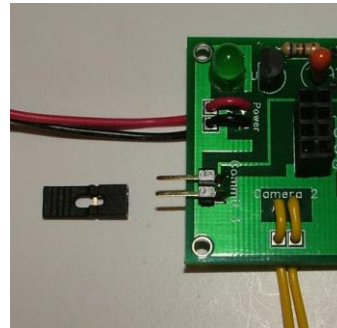
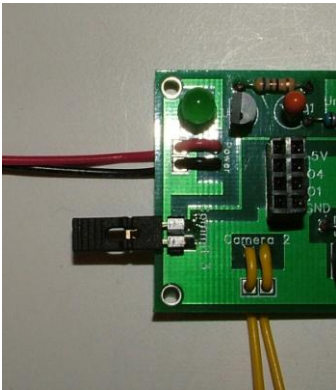
**Figure 18. A camera cable terminated in a two by two receptacle.**



**Figure 19. The camera plugged into the Flight Computer.**

## **Commit Pin**

As long as the Commit Pin (a shorting block) is on the flight computer, the PICAXE detects a logic low (zero volts or ground) on I/O pin 3 (thus the name, Commit 3). When the Commit Pin is removed, the PICAXE detects a logic high, or five volts on I/O pin 3.



**Figure 20 and 21. The Commit Pin on the flight computer and off the flight computer.**

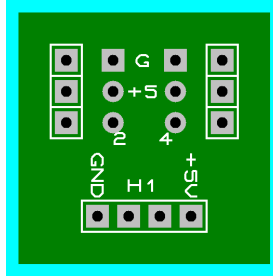
It is easier to pull the pin off than it is to push it back on. Therefore, the flight computer is programmed (by you) to wait for the removal of the pin before it begins recording data. The shorting block used for the Commit Pin is small enough that chances are that it will be lost or forgotten. To prevent this and to ensure the flight computer knows when to begin recording data, attach a brightly colored ribbon to the handle of the shorting block.



**Figure 22. A shorting block sporting a brightly colored ribbon for enhanced visibility.**

## Connecting Sensors

The BalloonSat Flight computer collects data from a sensor array consisting of two sensors. The sensor array terminates at a PCB with a four-pin header on one end. Each pin has one of the following functions, ground (zero volts or the negative terminal of a battery), two input channels, and +5 volts. The pins of the header are soldered to a printed circuit board and have a spacing of 0.1 inch between pins. The pins are 0.025 inches across.

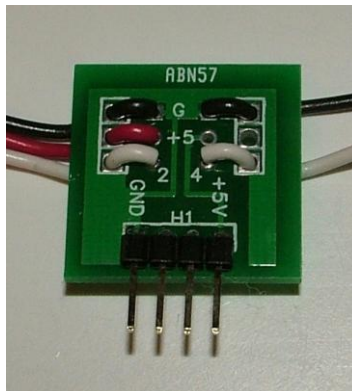


**Figure 23. The four pin header, how the BalloonSat's sensor array terminates.**

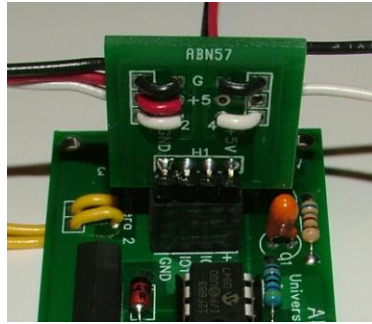
The benefit of using four-pin header is that sensors can be plugged into any I/O channel. And as soon as the header is plugged in, the sensor array receives power and communications with the PICAXE. The output from sensors plugged into the BalloonSat Flight computer can be either an analog voltage, a series of voltage pulses (on and off), or an on-off state.

To make the sensor terminator, solder the four-pin right angle header to the four pads marked H1. Solder the short ends of the header; leave the long pins free.

□ **4-Pin Right Angle Header**



**Figure 24. The terminator for a sensor array. The wires on the left and right sides connect to sensor PCBs. These will be added later.**



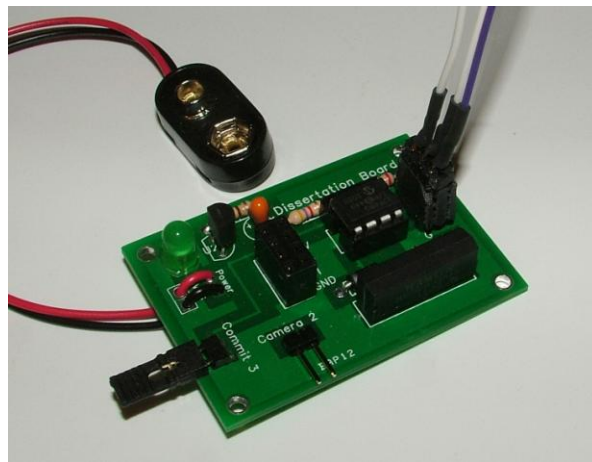
**Figure 25. A sensor array plugged into a flight computer.**

## Programming the BalloonSat Flight Computer

Download and install the latest version of the PICAXE Editor on a PC. The editor is similar to a word processor in that you'll write text and have the editor check it for syntax. Syntax is another word for rules. The program you will create for the flight computer uses a computer language called BASIC. The rules of BASIC are its syntax.

If your code follows the rules, then the editor will download it into the PICAXE-08M2 on the flight computer. Note that just because the syntax is correct doesn't mean the program will work. You must test the program by observing the flight computer and the way it collects and downloads data. Always save a copy of your program on the PC. It's much easier to modify old code than it is to create new code from scratch. When a program is downloaded into the PICAXE, it is stored in EEPROM memory. In EEPROM it will be remembered for at least ten years without power or a battery. When I receive your BalloonSat, you will have tested the code and make sure the latest version is currently in memory. I'll snap in a battery and your BalloonSat will start running your program.

The flight computer is programmed over a serial port on the PC. If your PC does not have a serial port, then purchase a USB to Serial adapter. The serial port ends in a male DB-9 connector. However, the BalloonSat flight is programmed through a three-pin header. In your BalloonSat kit is an adapter cable made of three wires (two white wires and one purple). The purple wire is the ground wire and it must connect to the pin with the letter **G** next to it (they're the ground connection).



**Figure 26.** The white and purple programming adapter plugged into the BalloonSat flight computer's programming port. The purple wire is the ground wire and must be connected to the pin with the letter **G** next to it.

## Examples of Code

This section contains examples of the commands used most often in a BalloonSat Flight computer flight program. These notes **are not** meant as a replacement for the PICAXE BASIC Commands Guide. You'll find the manual under the HELP option of the programming editor.

### **FOR**

This command instructs the PICAXE to begin a loop of program. The program loop is typically a sequence of commands that collects sensor values and stores them into memory. By using a program loop, the program only needs to be written once since it can be repeated ad infinitum. The FOR command is combined with a NEXT command to create a block of program that is repeated a fixed number of times during a near space mission.

### **HIGH**

The HIGH command energizes the camera relay onboard the flight computer. When the relay's electromagnet is energized, its magnetic field closes the relay's switch. The relay switch has replaced the shutter switch in the camera, so by using the HIGH 2 command, the camera is commanded to take a picture.

### **IF PIN3 =**

This command instructs the PICAXE to check the voltage on the Commit Header (the input pin 3 of the PICAXE-08M2). If the value of this pin is 1 (five volts) then the Commit Pin has been removed.

### **LOW**

The LOW command releases the shutter switch; however, the camera needs time to focus and record an image before releasing the shutter switch. Therefore, so use the PAUSE command after triggering the shutter, but before releasing the shutter.

### **NEXT**

This command instructs the PICAXE that this the end of the program loop. The sequence of commands between the FOR and NEXT statement will be repeated during the mission until an event specified in the FOR statement is met.

## **PAUSE**

The PAUSE command halts the program for a specified length of time. The time is given in units of milliseconds, or in 1/1000 of a second. The largest number that can be used with the PAUSE command is 65,535, or about 65.5 seconds. Use this command to add a pause between collecting data and taking pictures. Remember, your flight program needs to collect data for at least 95 minutes, so there needs to be a pause after each time the camera records data (including taking a picture). Without a pause, the entire mission will run in a few minutes at most.

## **READ**

This command instructs the PICAXE to read a value out of its 256 bytes of memory. The command when part of a FOR-NEXT loop will read out all the data collected during the BalloonSat's mission. To display the data on a PC, use the SERTXD command and the PICAXE Editor's built-in terminal program.

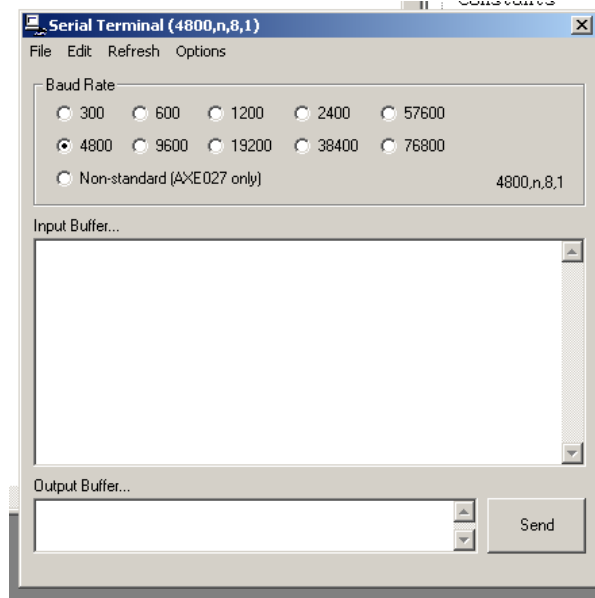
## **READADC**

This command instructs the PICAXE to digitize the voltage on a particular input pin. The voltage is digitized to an eight-bit level. This means the voltage, from 0 to 5 volts, is divided into 8-bits, or 256 units. Five volts divided by 256 units means each unit or count is equal to 0.0195 volts.

## **SERTXD**

This statement instructs the PICAXE to send text and data to a PC over the serial port from the flight computer's programming port. This means the same programming cable and connection to the flight computer used to program it also downloads its data. The Terminal program is an option under the PICAXE option of the menu. Be sure the terminal speed is set to 4800 baud or else the data will look like gibberish.





**Figure 27. The Terminal program in the PICAXE Editor. Under the Edit option, you’ll find the Copy Input Buffer option. Use it to copy the data displayed in the terminal program into a text file. The text file is then copied into a spreadsheet for processing.**

The SERTXD command does not know to display the data as a number or a text character. Therefore, you must precede the data to display with the pound sign or hash mark (#). Also, if you just SERTXD each memory location, the data will be displayed as a long string of numbers. Unfortunately, this means you won’t be able to tell where one memory value ends and the next one begins. Therefore, add a comma after each time your program displays the number stored in a memory location. The final SERTXD command will look something like this, SERTXD (#B0,”,”).

## **WRITE**

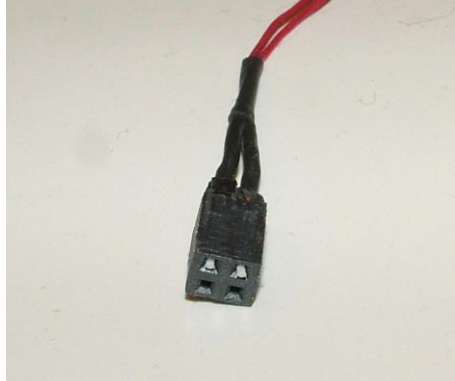
This command instructs the PICAXE to store a number, usually a sensor value, into memory. After the recovery of the BalloonSat Flight computer flight computer, the READ command retrieves the stored value.

## BalloonSat Camera



The camera in your BalloonSat kit was modified for the flight computer you are building. The camera comes with a 1/4-20 bolt and two washers. The camera must be bolted to the airframe of your BalloonSat. To help the Styrofoam airframe hold the bolt, there's also a small sheet of thick Polystyrene plastic. Drill a hole in the plastic and then glue it to the outside of the airframe. The plastic will spread out the stress of the bolt so it can't crush the airframe.

There's a power switch on top of the camera. The shutter button we removed and replaced with the red cable coming out of the camera. The place this modification took place is now covered with a layer of hot glue. The end of the cable terminates in a two-by-two receptacle. Two of the holes in the receptacle are plugged with small plastic dowels. The other two holes plug the cameras into the flight computer's Camera Port.



**Figure 1. The end of the camera's shutter cable.**

If you plug the shutter cable into the flight computer and turn on the camera, then the flight computer will record a picture with the following commands.

**HIGH 2**

**PAUSE 1000**

**LOW 2**

The HIGH command turns on the camera relay on the flight computer. When its energized, a switch inside of the relay closes. The camera is unable to tell if this switch is its original shutter button. Therefore, the relay takes the place of the shutter and triggers the camera. The PAUSE command holds the relay closed for 1000 milliseconds, or one second. The camera won't take a picture if its shutter is held down for too short of period of time. The LOW command shuts off the relay and releases the camera's shutter. By repeating the commands, the camera will continue taking pictures.

Check through the camera's menu. One setting you'll want to change is how long the camera will wait for the shutter before it turns off. There is no need for the camera to ever shut itself off, so find this setting and turn it off.

The BalloonSat kit comes with a polarizing filter and four theater gels (blue and red). The polarizing filter can be placed over the camera lens to detect the presence of polarized light in near space. When the theater gels are stacked up, they block visible light and only let near infrared light (NIR) enter the camera. According to the camera, the intensity of NIR is not as great as visible light. Therefore, the camera shutter must stay open longer. The BalloonSat will spin and swing during its mission. You can help dampen out this motion by adding two long

dowels to the BalloonSat. If the dowels stick out a few feet from the BalloonSat, their inertia will make it more difficult for your BalloonSat to swing around. You might even try adding light weights to the end of the dowels. But remember, your BalloonSat can't weight more than a pound.



**Figure 2. Example of a NIR image taken by the modified BalloonSat camera. The camera was set to record black and white images.**

## BalloonSat Sensor Array

The PICAXE-08M2 in the BalloonSat flight computer is a digital device. Being digital, it functions best with a series of on and off voltages and does not interact very well with a voltage that varies between being fully on and fully off (analog). However, there is a circuit inside the PICAXE-08M2 that interfaces to the world of analog voltages. The circuit is called an analog to digital converter, or ADC and is activated by the **READADC** command.

The PICAXE's **READADC** command converts an analog voltage into a digital value with eight bits of resolution. A bit is either a 0 or a 1, so eight bits ranges from the low value of 0000 0000 to the high value of 1111 1111. In binary, 0000 0000 is equivalent to a decimal value of 0 and a binary 1111 1111 is equivalent to a decimal value of 255. Therefore, the ADC converts a voltage between 0 and +5 volts to a decimal value between 0 and 255. The conversion is linear, so a decimal value of 0 is zero volts and a decimal value of 255 is five volts. This also means that a change of just one decimal value is equal to a change of 5 volts divided by 256, or 0.0195 volts (or 19.5 mV). Why did we divide five volts by 256 and not 255? Because there are 256 values between 0 and 255.

Okay, the **READADC** command converts an analog voltage into a decimal value, but how do we connect the sensor to the PICAXE and how do we get the decimal number of the sensor's voltage out? The entire command looks like this.

**READADC** channel,variable

For example, **READADC C.1,B0**

This example converts a voltage on the PICAXE's input 1 (on bank C) and stores the result in a variable named B0. The variable B0 is the first one byte variable in RAM memory. We know its one byte in size because its name begins with the letter B. A byte is eight bits wide, which is the same number of bits that the **READADC** command returns. Once the value is stored inside a variable, B0 in this case, it can be stored in RAM memory and displayed on a PC.

The simplest way to display the value stored in B0 use the command, **DEBUG**. The **DEBUG** command opens a window on the PICAXE Editor that displays every variable (B0 to B13) in the

PICAXE's memory. You'll need to look at the listing for B0 to see what value is stored in it. If you create a program loop that reads an analog value into memory and then displays it in the DEBUG Window, you can watch the sensor connected to your flight computer react to changing environmental conditions.

The problem with the DEBUG command is that it only displays data stored in RAM memory. Only 14 pieces of data can be stored in RAM memory and what is stored there, is forgotten as soon as the battery is disconnected. Therefore, you don't want to use RAM memory to store data for display data after a near space mission. To save a value currently stored in variable B0 into permanent memory location for later retrieval, move the data to EEPROM memory. There are 256 bytes of EEPROM memory for the long term storage of flight data and the **WRITE** command moves data from RAM into EEPROM. The **WRITE** command has the following syntax.

**WRITE** location,data

**WRITE** location,variable

For example, **WRITE 120,8**

or, **WRITE 95,B0**

The first example saves the decimal value 8 into memory location 120. That's not very useful because we are storing a specific number (8) into a specific EEPROM location (120). The second example is much better; it stores the value currently in variable B0 and stores it in memory location 95. Since there are 256 memory locations for data, you'll need to write this command 256 times to record all the data your BalloonSat flight computer can collect. How could you possibly add the WRITE command 256 times to the flight computer's program without running out of memory to collect data and take pictures? The best way to store the value in a variable into a memory location pointed to by the number stored inside a second variable.

For example, **WRITE B0,B1**

In this much better example, the value currently in variable B1 is stored in a memory location pointed to by the value in variable B0. After storing the value, increase the number stored inside B0 by 1 so it points to the next available memory location. You increment the value stored in variable B0 using the following command.

**B0 = B0 + 1**

After incrementing the value in B0, use the same **WRITE** command to store the newest value in variable B1 into the next available memory location. Executing these commands over and over stores a list of values into memory, without overwriting the earlier ones. This lets the flight computer record sensor values throughout the mission. Then after recovery of the BalloonSat, you can see how the sensor reacted to environmental conditions as the BalloonSat ascended.

After recovery, use the **READ** command to retrieve the values stored in memory. The **READ** command uses the following syntax.

**READ** location,variable

Like the **WRITE** command, the location can be either a specific number or a variable. By incrementing the value in the variable, the number stored in successive memory locations can be read out.

Let's put it all together and see what we get.

**Mission:**

**READADC 2,B0**

**WRITE B1,B0**

**B1 = B1 + 1**

**GOTO Mission**

**Readout:**

**READ B1,B0**

**DEBUG**

**B1 = B1 + 1**

## **GOTO Readout**

Now of course it won't be this easy. For one thing, how many sensor measurements does your flight computer need to collect, how often does it need to collect them, and when does the flight computer need to read out stored values? In addition, the values stored in memory are safe, even if power is lost to the PICAXE. However, reprogram the PICAXE to retrieve values stored in memory and the values will be overwritten before you can get them. Therefore, the program in the flight computer must be capable of both storing values during a mission and retrieving them after recovery.

So please read about the following commands and see what solutions you can develop.

**PAUSE**

**READADC**

**SEROUT**

**IF**

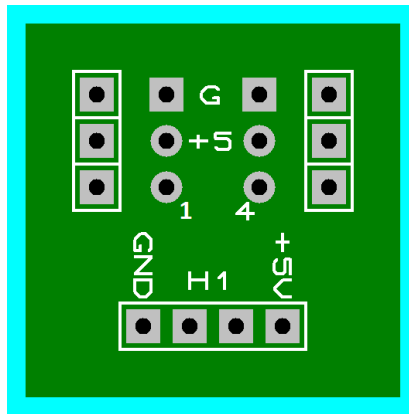
**THEN**

**PIN**

## **Building Sensor Arrays**

The BalloonSat flight computer digitizes two analog voltages on I/O pins 1 and 4. Virtually all sensors require power, so the flight computer's input port has connections for +5 volts and ground along with connections to I/O pins 1 and 4. When a sensor array of two sensors is plugged into the input port, the sensor array begins producing output as soon as the flight computer has power. The four-pin header PCB shown below plugs into the receptacle on the flight computer and connects the two sensors of your BalloonSat's sensor array.





**Figure 1. The four pin header used with the flight computer.**

You soldered a right-angle header of four pins to the bottom of a header when you built your flight computer. Now let's look at the soldering pads on the left and right side of the header. Notice there are two pairs of three pads on the left and right sides. A sensor soldered to the left side gets a connection to +5 volts, ground, and I/O pin 1 while a sensor soldered to the right side gets a connection to +5 volts, ground, and I/O pin 4. The top pad has a letter G, indicating these pads are for ground, or the zero volt wire of the sensor. The middle pin has +5 printed next to it, indicating these pads provide five volts to power to the sensors. The bottom pads have a 1 or a 4. Therefore, the power and grounds are shared between sensors, but not the I/O pins. A four pin header, when complete, looks like this.

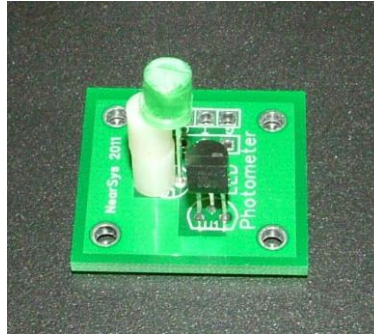


**Figure 2. This four pin header has two sensors soldered to it (the sensors are outside the image). Note that the right sensor only has two wires, ground and signal, connecting it to the four pin header. The left sensor is using all three wires, the black wire for ground, the red wire for +5 volts, and the white wire to connection to I/O pin #1 (although the header in this picture says its I/O #2).**

Normally a cable of three wires connects sensors to the four pin header. The cables are necessary because sensors are usually located away from the flight computer (the flight computer is inside

the BalloonSat while sensors are located outside the airframe). Also, notice that the header PCB has strain relief holes on the outside edges. Now let's look at the sensors.

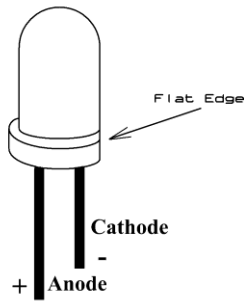
### LED Photometer



**Figure 3. The LED photometer with a green LED the LM335 temperature sensor.**

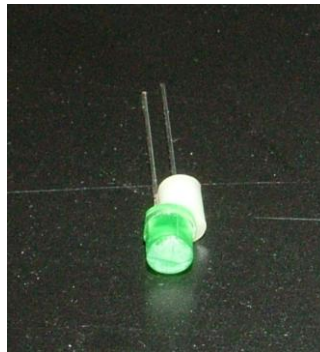
A photometer produces a voltage proportional to the intensity of the light shining on it (double the intensity of the light and the voltage also doubles). By using an LED in the photometer, it only detects the color of the LED. The photometer circuit converts the weak current signal from the LED into a voltage and amplifies it. The circuit that does this is called a transconductance amplifier and is based on the LTC272 operational amplifier (op-amp). An LED is sensitive to its temperature and not just the amount of light shining on it. Therefore, it is important that the temperature of the LED also be known. That's why next to the LED is a black-colored LM335 temperature sensor. **Note:** the LM335 looks a lot like the LP2950 voltage regulator used in the flight computer. Look carefully on the LM335 and you'll see that LM335 is printed on its face. When you use the photometer as a sensor, the flight computer is reading two pieces of data, the voltage from the LED (light intensity) and the voltage from the LM335 (temperature).

LEDs have a positive and negative terminal (called the anode and cathode). The LED Photometer PCB has an A next to the solder pad for the anode lead of the LED. The opposite of the anode, the cathode, is marked with a flat edge on the LED case.



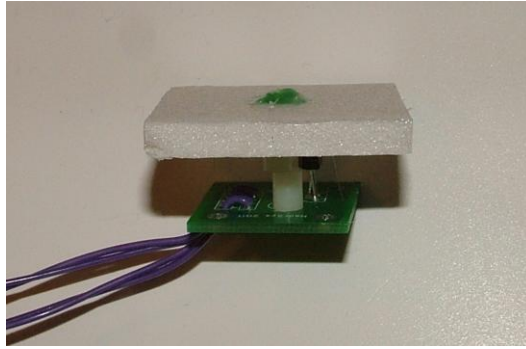
**Figure 4. The cathode of the LED is marked by a flat edge and usually, a shorter lead.**

To work properly, the LED in the photometer must stand higher than the LM335 temperature sensor. Use two plastic stand-offs on one of the LED leads to make the LED stand above the PCB as shown below. The top of the LED **must** be cut off and the top sanded smooth so that the LED is not as sensitive to its pointing direction. Do this before soldering the LED to the PCB.



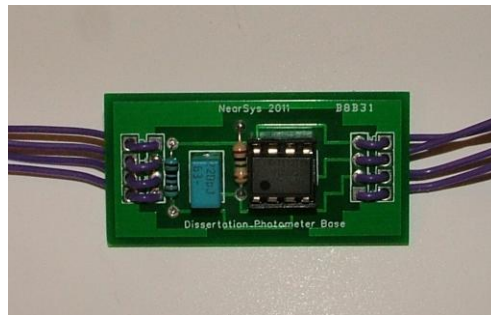
**Figure 5. A green LED with one of its leads (wire) sticking through a plastic spacer (a stand-off). Stack two stand-offs on one lead to get the LED to stand higher than the LM335 temperature sensor. The other lead of the LED can be left bare, you don't need to cover it up with a stand-off.**

The LM335 temperature sensor in the Photometer is black and will absorb sunlight. This makes the LM335 hotter than the LED. To keep the temperature of the LM335 closer to the temperature of the LED, add a sun shield to the LED photometer like the one shown below. The sun shield is a small sheet of white Styrofoam.

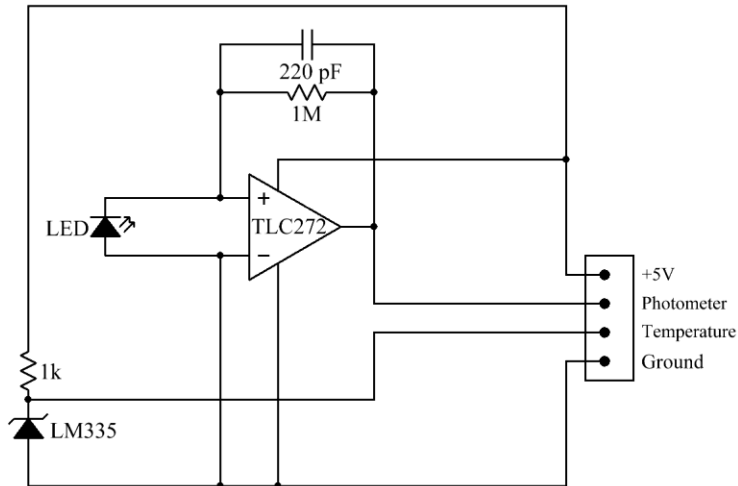


**Figure 6. The LED Photometer with its sun shield. The flattened top of the LED is looking out a small hole in the sun shield. The LM335 temperature sensor is shielded underneath the Styrofoam.**

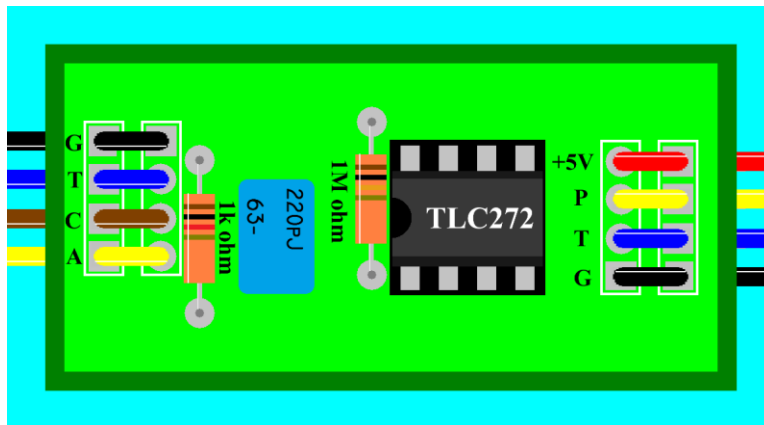
The small current produced by sunlight shining on the LED must be converted to a larger voltage before the flight computer can use it. The TLC272 op amp is part of a circuit called a transconductance amplifier that does this conversion.



**Figure 7. The transconductance amplifier is on a separate PCB and connects to the LED photometer by four wires.**



**Figure 8. Schematic for the LED Photometer.**

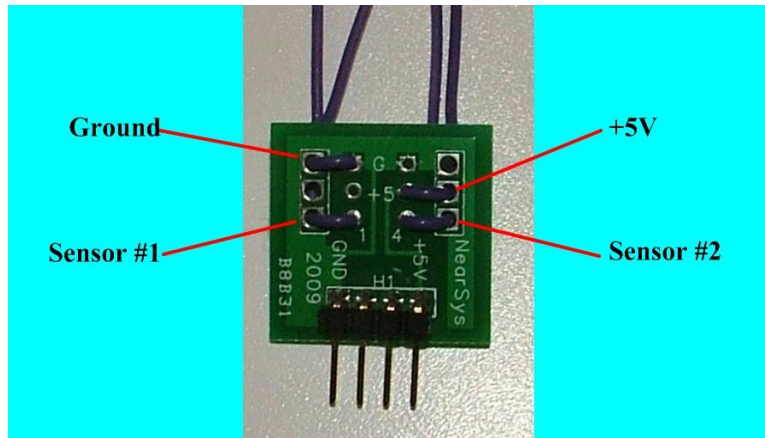


**Figure 9. Place of parts for the photometer's transconductance amplifier.**

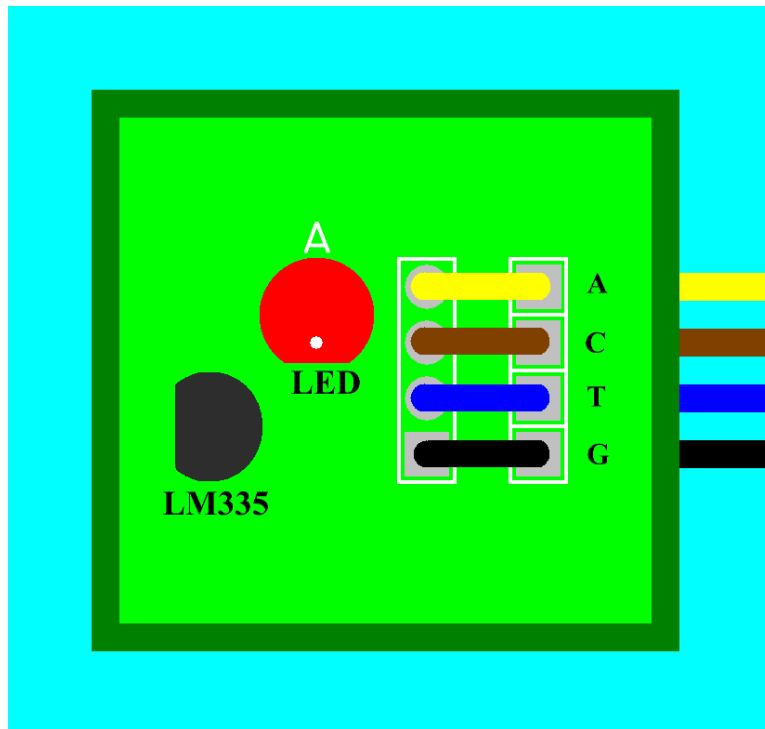
The capacitor and resistors are not polarized, but the op-amp is. Watch that you point the notch in the IC in the correct direction before you plug it into its socket. Use the one mega-ohm resistor (brown, black, green, gold) for a red, yellow, or green LED. An infrared LED (in a water clear case) can use a lower value, like the 220 kilo-ohm resistor (red, red, yellow, gold). The 1,000 ohm resistor is for the LM335 temperature sensor.

Use the strain relief holes when soldering the four wires to the PCB. The wires then run to the four-pin header PCB. At the four-pin header, solder the +5V and GND wires to opposite sides of

the PCB. Then watch carefully where you solder the sensor wires to the I/O pads of the four-pin header. The diagram below shows there are two wires on each side of the four-pin header.



**Figure 9. Solder two wires to each side of the four-pin header.**



**Figure 10. Place of parts for the photometer.**

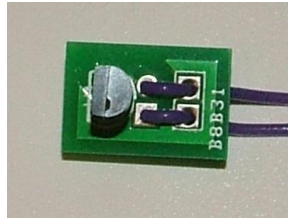
Don't forget, the domed-top of the LED must be cut off. You can use a hack saw or coarse sandpaper to flatten the top. After removing the top, sand the top of the LED until it's flat and smooth. The sandpaper will leave the top looking frosty. This is needed so the LED housing

doesn't focus sunlight on the silicon inside the LED. Both the LED and LM335 are polarized and must be soldered in their correct orientation for the circuit to work. Make sure the anode (A), cathode (C), temperature (T), and ground (G) wires properly connect between the transconductance PCB and the photometer PCB.

Also, note that the LED Photometer PCB can be used with any current device. So for example, a small solar cell can replace the LED. This allows the output of the solar cell to be measured during a mission.

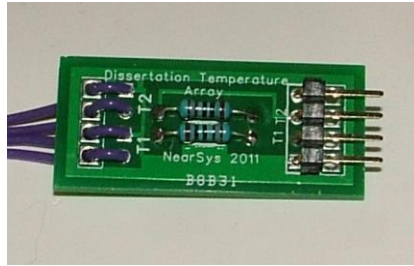
### Temperature Sensors

This is an LM335 electronic thermometer. Specifically, it is a temperature-controlled zener diode that produces a voltage between 0 and 5 volts for temperatures between 0 and 500 kelvins. The sensor looks like a little transistor. The white lettering (top silk) on the Temp Sensor PCB shows the proper orientation for the LM335.

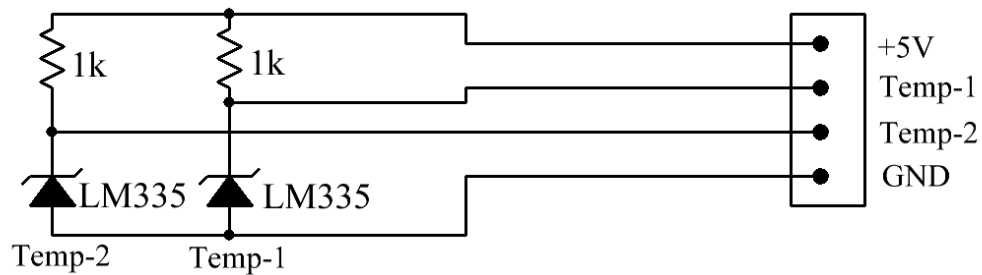


**Figure 11. The sensor portion of the temperature sensor. Look at its flat face to verify it really is a LM335 and not a LP2950. The name is stamped in small white letters.**

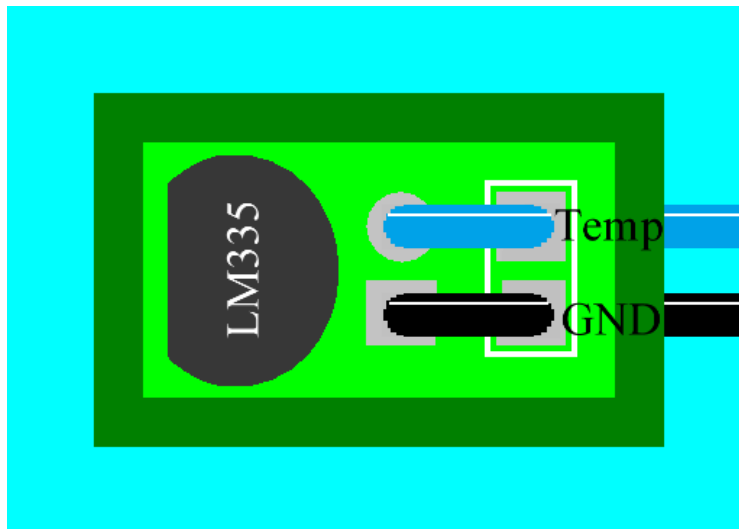
To make the LM335 produce a voltage, it needs a current limiting resistor of 1,000 ohms (brown, black, red, gold). The resistor also acts like a voltage divider when it is combined with the LM335. The PCB for the temperature sensors supports two LM335's and is called the temperature support board. Since it is a separate PCB, it can remain inside the BalloonSat airframe while two-wire cables attach it to each of the temperature sensor PCBs. The temperature support board can attach to a four-pin header PCB or you can just solder a four-pin header directly to the PCB as shown below.



**Figure 12.** The temperature support board. It contains two 1,000 ohm resistors and four wires running off to two temperature sensors. A right-angle four-pin header is soldered on the right side so the PCB will plug directly into the I/O port of the flight computer.



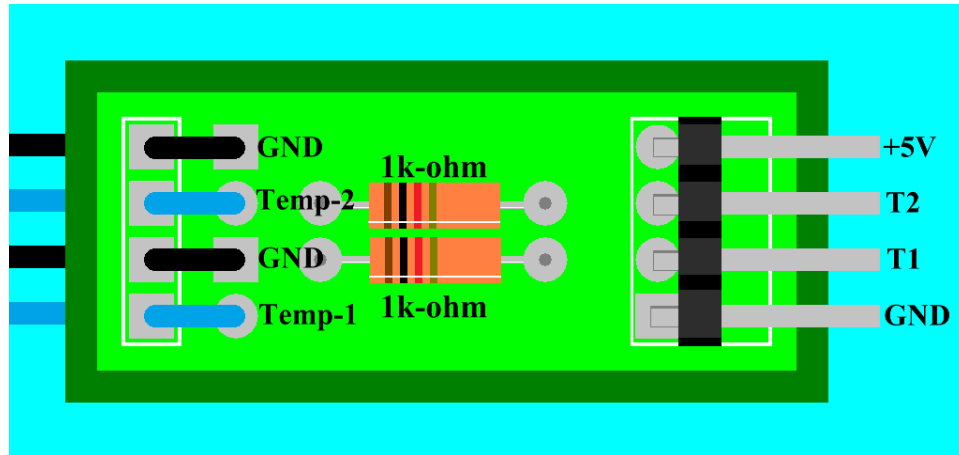
**Figure 13.** The schematic for the temperature sensor.



**Figure 14.** The placement of the LM335 and wires on the temperature PCB.



The LM335 is polarized, make sure you solder it to the PCB according to the white silk drawing on the PCB. Make note of which wire is ground and which is the output from the temperature sensor. The wires connect to the temperature support board and the wires must be soldered to the same pads on this PCB.



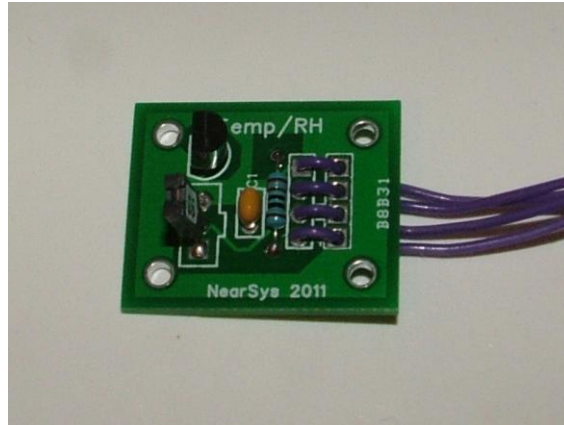
**Figure 15. Placement of parts for the temperature support board.**

The resistors are not polarized, just be sure to line up the wires from the two temperature PCBs with the solder pads on the board. Instead of soldering the output pads to wires and finally to the four-pin header PCB, just solder a four-pin, right-angle header directly to the PCB. Now the temperature support board will plug directly into the flight computer.

Consider shielding the temperature sensor from sunlight with the white plastic lid. That way solar heating doesn't affect the air temperature reading.

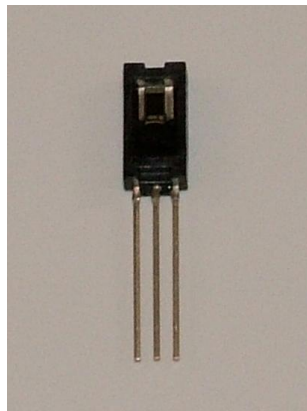
### **Temperature and Relative Humidity Sensor**

The HIH-4000 produces a voltage in proportion to the relative humidity. When combined with a LM335, this sensor array measures both relative humidity and temperature.



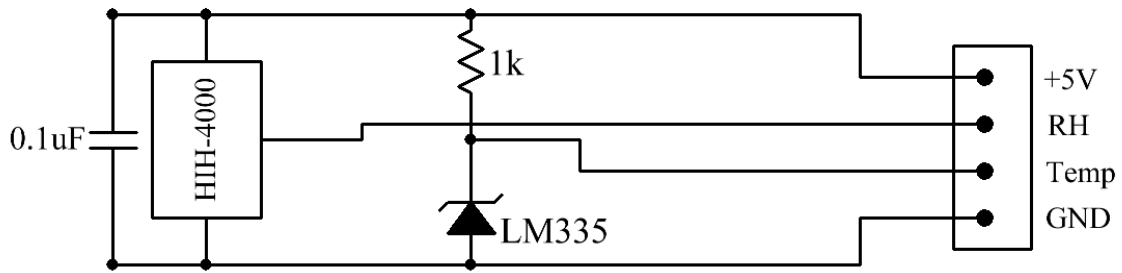
**Figure 16. The completed temperature and relative humidity sensor array.**

The relative humidity sensor produces an output that varies linearly with the humidity. The HIH 40000 sensor produces 0.8 volts at 0% relative humidity and increases by 0.031 volts for every 1% increase. The sensor has three leads, so it possible to solder it backwards. **Avoid this.** Notice the sensor has an open face on one side and is closed on the back. Inside the open face, the actual silicon sensor is visible as shown in figure 17.

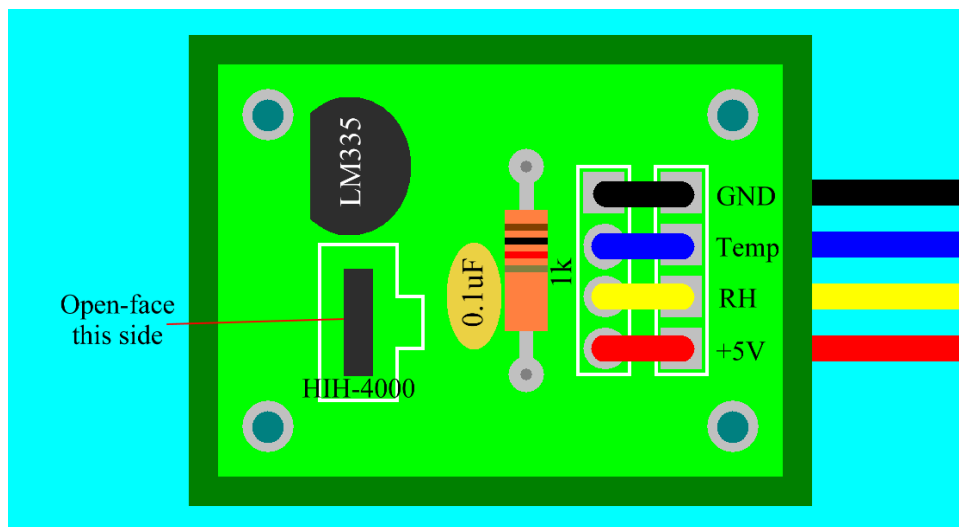


**Figure 17. Visible on this side of the HIH 40000 is the tiny humidity sensor.**

When you solder the HIH-4000 to the PCB, point the open face of the HIH-4000 away from the tiny 0.1 uF capacitor or towards the nearest edge of the PCB.

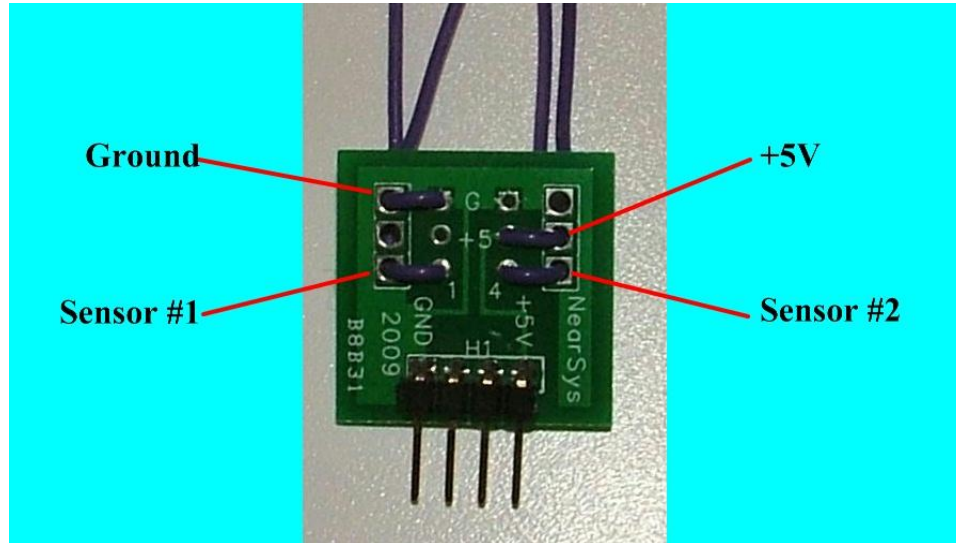


**Figure 18.** The schematic for the relative humidity and temperature array.



**Figure 19.** The placement of parts for the Relative Humidity-Temperature Array.

The LM335 and HIH-4000 stand slightly above the PCB after they are soldered, so don't try to force them flush to the surface. The capacitor and resistor are not polarized, but the temperature and relative humidity sensor are. Notice the direction of the relative humidity sensor's opened face in figure 19. Both the LM335 and HIH 4000 work better when protected from direct sunlight.



**Figure 20. Solder two wires to each side of the four-pin header.**

### **Finishing the Sensors**

After soldering the sensor arrays, you need to determine what data the BalloonSat is to collect and how to best deploy the sensor array on the BalloonSat.

### **Photometer**

Since the BalloonSat spins during its flight, it's best if you do not place the photometer on the side of the airframe. The LED is sensitive to temperature, so even if the light intensity does not change, its voltage will change as it gets colder. The change is linear, so if you can take a reading at the same light intensity but at different temperatures, you can determine the equation for adjusting the photometer's output based on temperature. Probably the best way to do this is to collect light and temperature data outside on a sunny day. Place the warm photometer outside during a cold day and leave the LED pointing in the same direction while the flight computer collects both temperature and light intensity data. Note that you are rapidly cooling the photometer while keeping it pointed in the same direction. As long as the data is collected over a few minutes and the LED can't change its orientation with respect to the sun, any change in the light intensity reading can only be due to the LED's temperature. Take two extreme temperature and light readings and find the slope and intercept of the equation that relates them. Then use this equation to adjust the photometer's readings after the BalloonSat mission to determine the change in light intensity.

The output of the photometer is linear with respect to light intensity (once you account for temperature effects). Therefore, if the photometer voltage has increased by 50%, then the light intensity has increased by 50%. In the spreadsheet, compare the photometer output to the first reading on the ground. However, first remember to adjust the photometer output for temperature.

The BalloonSat kit contains a sheet of Polaroid filter. If the Polaroid filter is placed over the photometer, then the photometer becomes photopolarimeter. Knowing the relationship of the sun to the BalloonSat might be important information in interpreting the results from a photopolarimeter. How could you tell which direction the photometer is pointed during its mission in near space?

### Temperature Array

Since there are two temperature sensors in this array, you can place each sensor in different locations and make comparisons. Inside and outside the airframe is one example. The sensors will also let you compare the effectiveness of insulation or the effects of color on temperature.

The output of each temperature reading must be converted to a temperature scale before its useful. The digital readings go from 0 to 255 while the temperature in Kelvins goes from 0 to 500. What spreadsheet equation will make this conversion? The relationship between digital reading and temperature is linear, so you only need to determine a slope and intercept. After converting the temperature into Kelvins, you'll probably want to convert the temperature into Celsius or Fahrenheit.

### Relative Humidity and Temperature

The lowest digital reading from the HIH-4000 is 41 and that occurs at 0% relative humidity. The highest reading is 199 and that occurs at 100% relative humidity. The output is linear, so if you can find the slope and intercept of the relationship described above, you can create an equation for converting digital readings into relative humidity.

The temperature sensor was described above.

### Getting Data from the Sensor Arrays

After your BalloonSat has been returned from its mission, your flight software must download the data it collected without you having to reprogram it. **Remember**, if you reprogram the flight computer, you will erase all the data collected. After your flight computer has finished downloading its data into the terminal program, click **Edit**, then **Copy Input Buffer**. Now start up Notepad and click on **Edit** and then **Paste**. The results will look like this.

```
150,210,150,209,149,208,147,208,146,207,144,206,142,205.....
```

Since there are two sensors, break the single line of data into two columns. The result looks like this.

150,210

150,209

149,208

147,208

146,207

144,206

142,205

.....

Save the text file and then open a spreadsheet program. Open the text file and import it into the spreadsheet. Name the columns after the data that was collected. In the example above, the data came from the relative humidity and temperature sensor array. I'll name the first column Temperature and the second column Relative Humidity.

In the next columns, add the equations needed to convert the flight computer's digital values into actual readings you can use. Then are you ready to make charts?

### **Importing Altitude into the Spreadsheet**

Your BalloonSat probably recorded data once per minute. In some experiments, knowing just the time of the reading is good enough; however, in other cases, you will want to know the altitude of the BalloonSat instead of the time. On the NearSys website, you will find a spreadsheet generated from the APRS log used to track the balloon that carried your BalloonSat. The spreadsheet will have the time and altitude of the balloon. You can take each altitude at each minute of the flight and add it to a new column in your BalloonSat's spreadsheet.

Your BalloonSat will begin recording data a minute or two before liftoff. Therefore, you'll need to take that into account when adding altitudes to your spreadsheet. After this, you can begin making charts of your data.

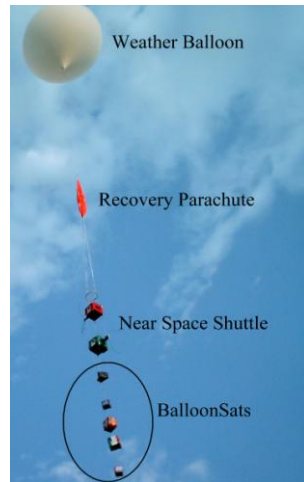
## **CONSTRUCTING BALLOONSAT AIRFRAMES**

In near space, experiments need a container to hold and organize them. This chapter is about that container, the BalloonSat airframe. This chapter discusses the materials, tools, and methods used to machine and assemble a BalloonSat airframe. Afterwards, there's a suggested step by step assembly procedure. However, since the size and shape of your BalloonSat depends on the experiments inside of it, use this chapter as guidance and not rules.

### **2.1 THE BALLOONSAT CONFIGURATION RECOMMENDED BY THIS BOOK**

The BalloonSat recommended in this book is a Styrofoam box with a hatch in front with two rubber bands stretched over it to keep it closed during its mission. The ends of the rubber bands hook to the BalloonSat through closure dowels on the side of the airframe. During its mission, your BalloonSat and others hang below the near space shuttle on four cords called the suspension lines. The suspension lines pass through the walls of the BalloonSats, allowing each to hang in series, one after the other. Protecting the Styrofoam walls of the BalloonSat from abrasion by the suspension lines are suspension tubes, plastic tubes embedded inside the Styrofoam. Each BalloonSat is free to slide up and down the suspension lines, within limits. Split rings on the suspension lines prevent the BalloonSats from sliding too much on the suspension lines.

The near space shuttle contains the GPS receiver and radio equipment needed to track and recover the flight. Therefore, you won't add tracking electronics to your BalloonSat. Since the near space group providing the launch already provides the tracking and recovery services, your BalloonSat only has to operate its experiments and record its data for download and analysis after its recovery.



**FIGURE 2-1. A chain of five BalloonSats suspended below a dual-redundant near space shuttle. The redundant modules in the shuttle ensure the mission's success even if there's an electronics failure during the 2-1/2 hour mission. Above the two modules of this particular near space shuttle is its orange recovery parachute and balloon (the near space booster).**



**FIGURE 2-2. A sight everyone wants to see, the near space shuttle with its payload of BalloonSats safely on the ground. The next stop for these BalloonSats is a return to their owner for data analysis.**

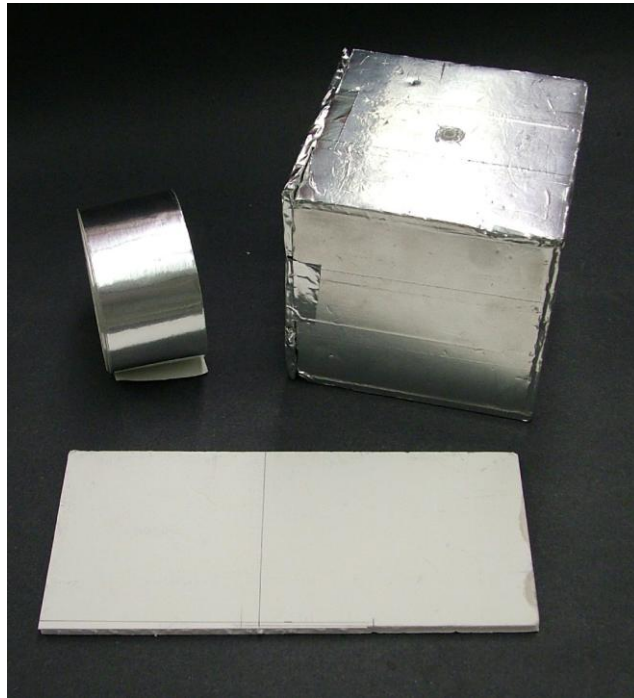


## 2.2 MATERIALS



**FIGURE 2-3. An example of a traditional BalloonSat airframe.**

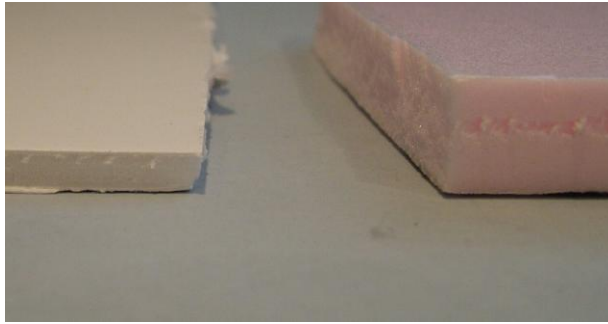
The traditional BalloonSat is a cube constructed from foamcore and aluminum duct tape. Foamcore, a 3/16 inch Styrofoam sheet with paper facing, and is a popular backing for printed artwork like posters. It's available in 20" by 30" sheets at many art and big box retailers. Aluminum duct tape is a thin metal foil with an adhesive coating. Most home improvement stores carry it in rolls two inches wide and 50 feet long.



**FIGURE 2-4. The traditional materials of foamcore and aluminum duct tape.**

Instead of foamcore and aluminum tape, the BalloonSat Principia recommends constructing a BalloonSats with  $\frac{1}{2}$  inch thick Styrofoam and colored poly shipping tape. Styrofoam is light in weight, easy to cut and shape, and quick to glue together. It's available in four by eight foot sheets at many home improvement stores who sell it for home insulation. Be careful; this is not the beaded white Styrofoam sheets, which are also available at home improvement stores. White Styrofoam is too crumbly and fragile to make a good BalloonSat airframe. The proper Styrofoam is light blue (not white), solid, and with a fine grain. Home improvement stores sell several thicknesses of this material, but it's the  $\frac{1}{2}$  inch thick material you want to use. There's no need to use the thicker stuff as it adds unnecessary weight to your BalloonSat (but it does increase its insulation). The colored poly shipping tape is the same tape hobbyists use to cover the wings and fuselage of Styrofoam gliders. The company Uline (see the later reference) sells this tape as does many hobby stores that carry Styrofoam gliders.

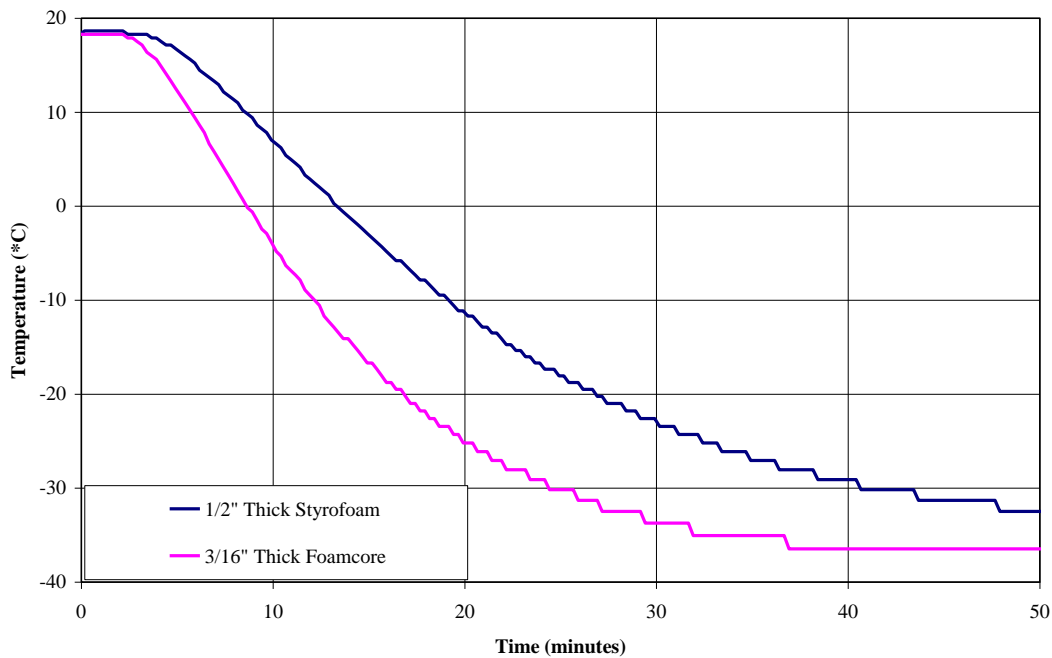
### 2.2.1 Comparing Styrofoam to Foamcore



**FIGURE 2-5. A close up of Foamcore and Styrofoam. Foamcore is heavier than 1/2 inch thick Styrofoam per unit area and doesn't insulate as well. Because of its paper covering, it doesn't stand up to moisture as well as Styrofoam either. Styrofoam is expanded polystyrene plastic. It's lightweight and insulates well because of the trapped air in its cell structure.**

A 25 square inch sheet of Styrofoam weighs 8 grams while the same area of foamcore weighs 10 grams. Therefore, a 1/2" Styrofoam BalloonSat airframe is 20% lighter than an equivalent foamcore BalloonSat airframe. Reduced weight is not the only benefit of using Styrofoam. Placing a traditional BalloonSat inside a Thermal Test Chamber along side a Styrofoam replica illustrates a second benefit of using Styrofoam; a Styrofoam BalloonSat is warmer inside than a foamcore BalloonSat.

## Cooling Rates



**FIGURE 2-6.** The interior of a Styrofoam BalloonSat takes nearly 20 minutes longer to cool to the same internal temperature as a foamcore BalloonSat. Its warmer internal temperature will protect its internal batteries and electronics from the extreme cold of near space for a longer period of time.

According to the experiments of Galileo, the thicker a material, the greater strength it has. Therefore, it's reasonable to assume that 1/2 inch thick Styrofoam is stronger (resists bending) than 3/16 inch thick foamcore. However, foamcore is a Styrofoam sheet with a bonded paper surface. That makes it a composite and in general, composites are stronger than their constituent materials. Is thinner foamcore really stronger than thicker Styrofoam? Appendix I explains how to test the strength of materials.

### 2.3 STYROFOAM TOOLS

Most of the tools required to convert a sheet of Styrofoam into a fleet of BalloonSats are common to other hobbies. Therefore, you probably already have most of the tools you need to measure, cut, shape, and assemble Styrofoam.

**TABLE 2-1. Tool List.**

Metal Straight Edge

Exacto Knife

Hollow tubing \*

Hollow channel \*

Emory Board (cardboard nail file)

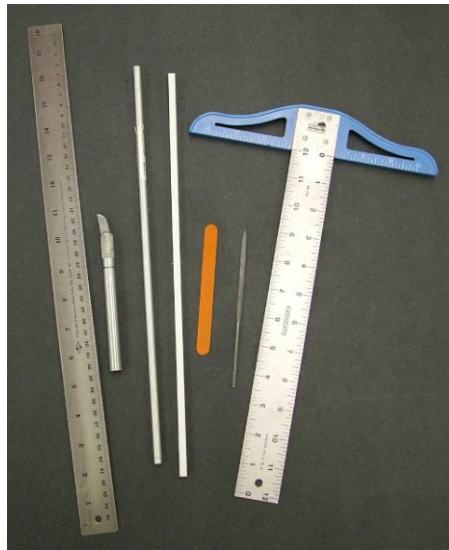
Metal Hobby Files

T-square

Pencil

Hot Glue Gun

\* Made from aluminum, brass or plastic



**FIGURE 2-7. Airframe machining tools, except for the pencil and hot glue gun.**

## 2.4 MACHINING STYROFOAM

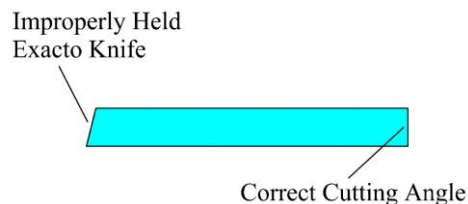
This section briefly describes the cutting, drilling, channeling, and sanding operations you need to know to make a BalloonSat airframe. In some ways, a BalloonSat is a near space version of a CubeSat. Since Styrofoam is easier to machine than aluminum, a BalloonSat is easier and faster to make than a CubeSat.

### 2.4.1 Cutting Sheets

One difficulty is cutting a clean edge in Styrofoam. Table saws cut clean edges in Styrofoam, as does a hot wire. A table saws naturally cuts straight lines while a hot wire requires a very steady hand or a jig to cut a straight line. If don't have access to either of these tools, and can't justify purchasing them, then the only option is to cut Styrofoam with an Exacto knife.

Styrofoam cuts well with a sharp Exacto knife and metal straight edge. In addition to the knife and straight edge, you'll need a T-Square to draw right angle corners and a protractor to mark out non-square edges (no one said your BalloonSat had to be a cube).

Use a metal straight edge and T-square to lay out the cut to make in your Styrofoam sheet (don't use wooden straight edges as the Exacto knife will nick and create a crooked line). Press lightly with your pencil and don't gouge the Styrofoam when you draw a line. Load a new #11 blade in your Exacto knife handle. Place the metal straight edge along the line and hold the Exacto knife as close to perpendicular as possible. If the Exacto knife is not perpendicular, the cut edge will look like the diagram below.



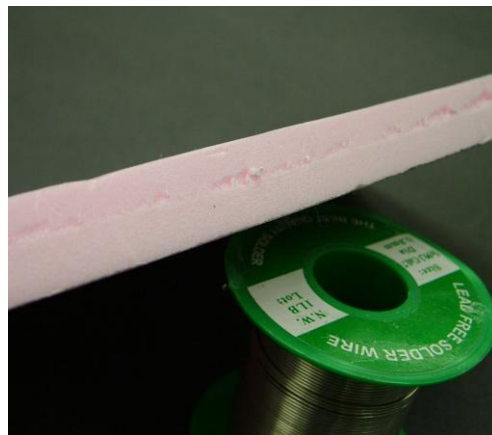
**FIGURE 2-8. Good and bad cuts through Styrofoam.**

Make several cuts through the Styrofoam; don't cut through in a single pass. Begin your cut with the Exacto knife held vertical, but leaning back. When the Exacto blade leans back, it slices through the Styrofoam and is less likely to chip it.

As the blade of the Exacto knife begins to dull, it begins cutting better in one direction than in the perpendicular direction. Apparently, a “grain” is created in Styrofoam when it’s extruded. As the Exacto blade dulls, it begins to chip or break out chunks of Styrofoam instead of making smooth cuts. Be prepared to replace the blade when the Exacto begins to make bad cuts.



**FIGURE 2-9.** The edge of Styrofoam cut with a dull blade (A very dull blade was used to emphasize the damage done by a dull blade).

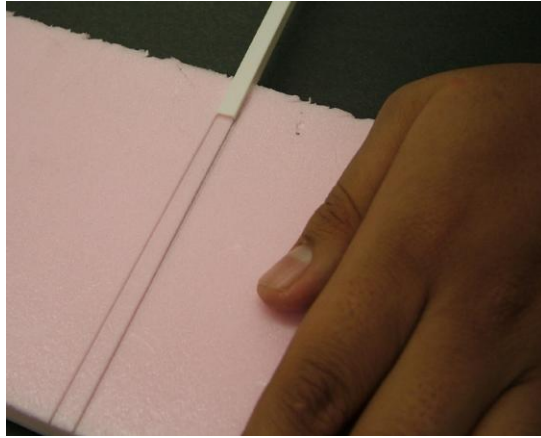


**FIGURE 2-10.** The cut edge of this Styrofoam sheet is much smoother because it was cut with a newer, sharper blade.

Since you can go through a lot of blades making BalloonSats, purchase your Exacto blades in the black plastic box of 25 blades. In bulk, the cost per blade is lower and besides, the box protects the unused blades and is a safe place to dispose of the used, but still sharp, blades.

## 2.4.2 Cutting Channels

An easy way to cut channels into Styrofoam is to cut two parallel lines and then run a sharpened brass channel between the lines. Back the channel out occasionally to clear it of Styrofoam shavings. A sharpened square plastic tube can also cut channels as described in the next section.

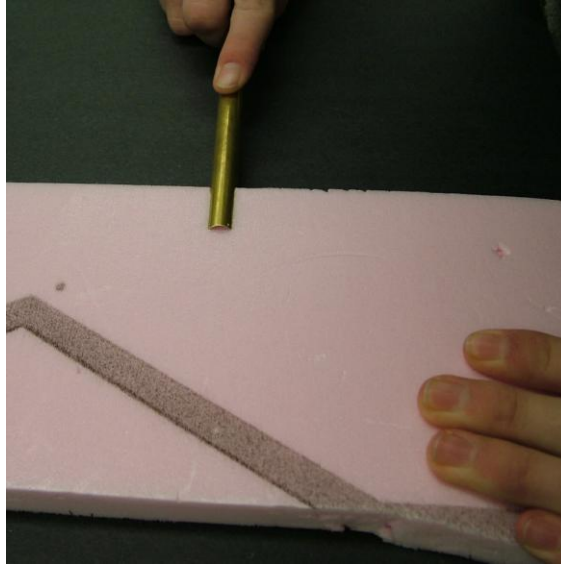


**FIGURE 2-11.** Using a sharpened channel, plastic in this case, to clear out the space between two parallel cuts.

## 2.4.3 Drilling Holes

A drill bit doesn't usually cut clean holes through Styrofoam; in fact, it tends to tear it up. So use a sharpened brass tube. Sharpen the inside edge of the brass tube with a small metal hobby file then twist the brass tube as you push it through the Styrofoam. Occasionally pull the tube out of the hole to clean out the Styrofoam shavings.





**FIGURE 2-12.** This person is twisting the brass tube as he pushes it through the Styrofoam. He's also being careful to keep the tube at a constant height relative to the Styrofoam so the hole is straight.

#### **2.4.4 Sanding**

Cardboard nail files and hobbyist metal files shape and smooth edges in Styrofoam. A piece of sand paper can also shape the edges and faces of Styrofoam. There are two ways to maintain a flat surface on Styrofoam while sanding it. The first is to lay the sand paper face-up on a flat surface and run the Styrofoam back and forth on the sand paper. The second is to sand the Styrofoam with a stationary belt sander. However, be aware that sanding a glued piece of Styrofoam with a belt sander will eventually gum up the sanding belt.

### **2.5 CONSTRUCTING AIRFRAMES**

**TABLE 2-2. Materials to assemble an airframe.**

Styrofoam sheet, 1/2 inch thick

Color coded or colored poly shipping tape, 2.2 mil thick \*

Wooden dowel, 3/16 inches in diameter

Polystyrene tubing, 1/4 inch in diameter \*\*

Rubber bands

Black enamel modeling paint or black felt tip marker

**TABLE 2-3. Optional materials.**

Foamcore

Aluminized Mylar (space blanket)

Scrim (wedding veil material)

Kapton tape (1/4 or 1/2 inch wide) \*\*\*

Black plastic model paint or black felt tip marker

\* Uline ([www.uline.com](http://www.uline.com)) sells this tape as item S-700. It's also available at many hobby stores that sell Styrofoam gliders. Modelers like to wrap the tape around their Styrofoam gliders in place of painting them. In addition to adding color, the tape makes the glider more durable.

\*\* Plastic tubing is available at many hobby stores.

\*\*\* Also available at Uline



**FIGURE 2-13.** Half inch thick Styrofoam along with a wooden dowel and hollow plastic tubing. The rolls of tape in the center are a 2.2 mil color coded tape at the top and a roll of Kapton tape below. Both rolls of tape are available from Uline. Kapton is the material used to hold thermal insulation together on real satellites. Space blanket, on the right side, is another covering material for BalloonSats that will help to give yours a real spacecraft look.

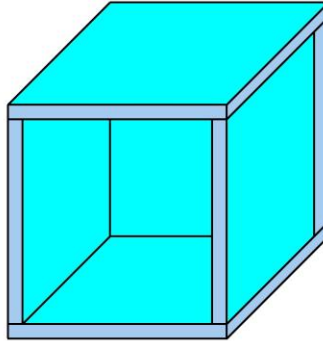
### 2.5.1 Dimensions of Airframe

First layout the contents of your BalloonSat, then position each item as you want it organized inside the BalloonSat. Take your time and make sure each component will work well in its place and not interfere with each other. Sensors that need to sample the outside environment must be located next to the wall of the airframe and cannot be buried inside. Items that need to be manipulated shortly before launch must to be easily accessible from the hatch of the BalloonSat and not buried deep inside the airframe either.

Once you're happy with the placement of components, measure their outside dimensions. The BalloonSat you'll now design must have an interior volume large enough for the arrangement you just measured.

Before drawing the sides of the airframe, remember that the Styrofoam has a thickness of  $\frac{1}{2}$  inch. Also, include a hatch in your design. The hatch covers one entire side of the airframe; it

can't be on the top or bottom of the airframe. Now draw and cut out the sides. A simple cubic BalloonSat will have an arrangement of sides as illustrated below.

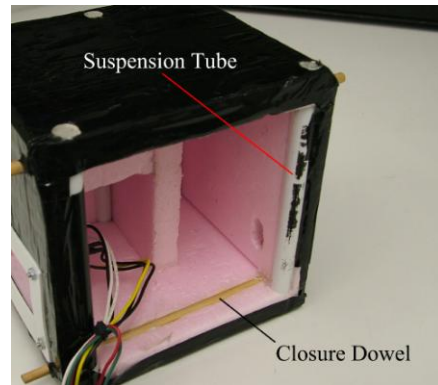


**FIGURE 2-14. An opened airframe displaying a recommended placement of sides.**

Don't start gluing the sides together yet; test fit them to make sure they were cut correctly. The only side that should be a little larger than necessary is the hatch, as you'll trim it to the proper size after the airframe is glued together.

### **2.5.2 Channels in the Sides**

Before gluing can begin, you must cut channels in the Styrofoam sides for the suspension tubes and the closure dowels. Remember that the suspension tubes are vertical hollow plastic tubes and the closure dowels are horizontal (usually) wooden dowels. A BalloonSat should have four suspension tubes for stability and two closure dowels for security. However, these numbers can change depending on the near space group carrying your BalloonSat and the volume of your BalloonSat. Place the vertical plastic tubes and horizontal wooden dowels so that they won't cross each other. The photograph below shows one possible arrangement.



**FIGURE 2-15.** The closure dowels reside further inside this BalloonSat airframe than the suspension tubes. Because of this, the dowels don't pass through the tubes.

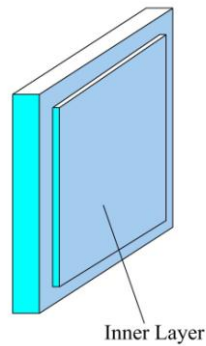
After drawing guide lines on the Styrofoam, either cut shallow slits into the Styrofoam and push a square channel tube through the Styrofoam or push and twist a sharpened metal tube just below the surface. Check the depth and diameter of the channels making sure the tubes and dowels fit properly. Do not glue the tubes or dowels into place yet.

### **2.5.3 Gluing the Airframe Together**

Check the fit of your pieces before gluing them together. Use hot glue, but watch its temperature since hot glue can melt Styrofoam. When it gets too hot, unplug the glue gun to let it cool. Cooling hot glue can still glue Styrofoam as long as it doesn't cool too much. Assemble the airframe except for the hatch.

### **2.5.4 Making the Hatch**

The hatch needs an inner layer that fits snugly inside the opened airframe, so cut a sheet of Styrofoam to fit the opened airframe. Check the fit once again. Now glue this piece of Styrofoam on the center of the hatch. After the glue cools, close the BalloonSat airframe with the hatch and mark the edges of the airframe on the hatch. After removing the hatch, you can trim it along the lines. In place of  $\frac{1}{2}$ " thick Styrofoam, you can use thinner foamcore for the hatch's inner layer.



**FIGURE 2-16. The two layer design of a BalloonSat hatch.**

### **2.5.5 Covering the BalloonSat**

The easiest way to add color to the exterior of a BalloonSat is with colored tape. To minimize the BalloonSat's final weight, use a thin colored poly tape like color-coding or Styrofoam glider tape. Don't use colored duct tape as it adds needless weight. The same applies to aluminum duct tape. It looks nice, but it too adds unneeded weight.

The tape strips should be long enough to go around three of the sides of the airframe plus a bit longer so they end and begin inside the airframe. Apply each strip of tape with a little overlap between strips. Rub down the tape to ensure it has a good contact with the Styrofoam.

### **2.5.6 Suspension Tubes and Closure Dowels**

Measure the length of the airframe where the plastic suspension tubes will fit. Cut the tubes to that length and sand their cut edges slightly to remove burrs. Use an Exacto knife to cut out holes in the tape where it covers the openings to the channels. A little hot glue on the plastic tube is enough to hold it after sliding it into the airframe. However, don't use much glue, as it oozes out of the channel when the tube slides in making a mess.

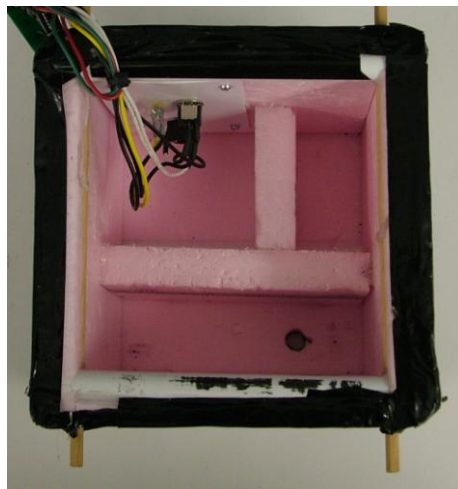
The closure dowels need to be cut one inch longer than the dimension of the airframe where they will be inserted. That way the dowels will protrude  $\frac{1}{2}$  inch from the airframe, long enough for the rubber bands. After cutting the dowels, sand their ends slightly to round them. Use either white glue or hot glue to hold the dowels in place. After the dowel is glued you may

want to add additional hot glue around the dowel where protrudes from the airframe. A small bead of glue will help protect the exposed edges of the tape around the dowel.

## **2.6 FOUR VARIATIONS IN DESIGN**

### **2.6.1 Internal Shelves and Dividers**

An experiment that needs support or separation from another experiment will benefit if there's shelves inside the BalloonSat airframe. Glue the shelves and dividers directly to the interior walls of the airframe after the airframe has been glued together. This is another good use for foamcore.



**FIGURE 2-17.** An example of a shelf and divider inside a BalloonSat.

### **2.6.2 Multilayer Insulation**

Multilayer insulation (MLI) is the material used to insulate real spacecraft. A jacket of MLI acts like a lightweight and unbreakable Dewar or thermos bottle. Space certified MLI is very expensive, on the order of one dollar per square inch. However, you can make an inexpensive substitute. While MLI works best in a hard vacuum found in space and won't be as effective in near space, it's still fun to make.

**TABLE 2-4. Materials to make MLI**

Sewing machine

One package of space blanket

One yard of plastic wedding veil material

Kapton tape, 1/4 inch wide \*

\*Kapton tape is available from Uline ([www.uline.com](http://www.uline.com)) as product S-10518

MLI consists of alternating layers of aluminized mylar and scrim. The aluminum coating on the Mylar reduces cooling by radiative cooling by reflecting thermal radiation back into the BalloonSat. Scrim minimizes cooling by thermal conduction by creating a physical separation between the layers. The near vacuum between the layers reduces the loss of heat by convection.

Make your MLI jacket by sewing alternating layers of Mylar and scrim together. The layers should begin with a Mylar layer on bottom and end with a Mylar layer on top. Cut each layer the same shape that will fold properly to cover the airframe. However, the top layer of Mylar needs to be cut a little larger so its edges can fold over the bottom layer of Mylar. Cutting MLI layers should remind you of making paper polyhedrons in middle school. After cutting the layers out, stack the alternating layers of space blanket and wedding veil material and then fold the edges of the top space blanket layer over the bottom layer. Hold the stack together and run it through a sewing machine. Only sew around the edges, there's no need to sew through the middle of the stack. When they're sewn together, you'll have a durable thermal blanket that won't come apart.

Sew a second MLI jacket for the hatch, but in this case, the MLI is shaped to wrap around the face and sides of the hatch with a little bit protruding inside the hatch.

Now you can wrap the MLI around the airframe and use Kapton tape to hold it together. When complete, the BalloonSat airframe will look more like a professionally built satellite.

### **2.6.3 Ports**

Some experiments need to sense or see the world outside the airframe. Examples include temperature and relative humidity sensors and cameras. Ports are the openings in an airframe for these types of experiments. If they're needed, they must be cut before the airframe is covered. Begin making a port by marking its placement on the airframe with a pencil. Use a T-square if you want the openings to be square. Cut the port opening with a sharp Exacto knife and sand the



edges if they're too rough. For camera ports, paint the exposed edge of the port with black plastic model paint or a black felt tip marker to reduce the glare.

#### **2.6.4 External Sample Holders**

Some experiments need complete exposure to the near space environment. For these experiments, a plastic coin tube makes an excellent holder. The tubes have screw-on caps, so they're easy to open and close. And since they're transparent, their contents can easily be observed. One way to use a plastic coin tube is to glue a Styrofoam shelf to the outside of the BalloonSat that the coin tube can sit on. By inserting additional dowels in the airframe, rubber bands can secure the tube to its shelf.

Alternatively, a hole large enough for the plastic coin tube can be drilled into the airframe. Then the tube can be inserted into the BalloonSat with at least its cap protruding outside the airframe. Be sure the hole is just large enough for the tube as it must be snug so the tube won't fall out on its own.

### **2.7 COMPLETING THE AIRFRAME**

Just in case your BalloonSat is separated from the rest of the near space shuttle during its mission, put a label on the airframe with your name and phone number. The suspension lines should never break, but accidents can happen. With a name and phone number on your BalloonSat, there's at least a chance it will be returned. The label can be made with a label maker or PC printer and then covered with transparent tape.

Now close hatch and wrap rubber bands over closure dowels and hatch. You have a completed BalloonSat airframe ready for loading your experiments.



**FIGURE 2-18. A completed and closed BalloonSat.**

# TESTING BALLOONSATS

The near space environment and flight into near space are difficult at times, and the BalloonSat must function properly in this environment, without losing parts or being difficult to launch. The six performance tests described in this chapter simulate many of the aspects of the near space mission. By successfully completing them, the BalloonSat Program Manager can be confident that each BalloonSats will be successful. However, since the BalloonSat Program Manager must accept the risks associated with the BalloonSat launch, they must decide to accept or modify the standards for each test.

Some of these tests are not appropriate rejecting a BalloonSat for the mission. Instead, they provide evidence for needed improvement. In addition, the BalloonSat Program Manager can use the results of these tests to generate a score for BalloonSat Team evaluations. The recommended six tests are Weight, Functional, Thermal, Drop, Shake, and Prep.

## 4.1 WEIGHT TEST

One requirement for the BalloonSat Program Manager is to give several requirements that each BalloonSat must meet. The maximum allowable weight for each BalloonSat is one of them. Therefore, during construction, each BalloonSat Team should be weighing their creation. The final results of the weight test should not surprise any of the BalloonSat teams.

### 4.1.1 Weight Test Background

Since the Federal Aviation Administration imposes weight limits to untethered balloon flights, the combined weight of the mission's BalloonSats is limited. To be equitable about this requirement, the total available payload weight for the missions is divided equally amount the BalloonSats.

### 4.1.2 Weight Test Procedure

Use an inexpensive digital hobby scale for this test.

- Load each BalloonSat with its internal experiments, including batteries
- Seal the BalloonSat hatch with rubber bands
- Record the weight of each BalloonSat in writing

### Pass Criteria

- Any BalloonSat weighing less than the allowed maximum is ready for the next test.

**Note:** The traditional maximum weight allowed for BalloonSats is 450 grams (one pound). BalloonSat teams should be encouraged to create the lightest weight BalloonSat capable of carrying out the most science by developing a scoring system that grants higher scores to lower weights.



**FIGURE 4-1.** A middle school student weighing his BalloonSat.

## **4.2 FUNCTIONAL TESTING**

Functional testing ensures the BalloonSat is capable of carrying out its mission. Because of the costs associated with a near space launch, it's not justified to launch a BalloonSat with a high risk of functional failure.

### **4.2.1 Functional Testing Background**

The costs associated with a near space launch can be broken into three categories, risk, flight, and time.

#### **Risk Cost**

On every near space mission, there's a small risk that the near spacecraft will get lost. Redundant back-up trackers onboard the near spacecraft mitigate, but do not eliminate, this risk. If the trackers should fail, the predicted flight path has significant error, and the recovery zone is located in a desolate or low populated region, may prevent the return of the near spacecraft. A near spacecraft consisting of just two independent APRS trackers can cost over \$300.

Not only does the owner of the near spacecraft face this risk, so does the BalloonSat Program Manager who purchased the items to construct the BalloonSat. The cost of a BalloonSat can approach \$100.

#### **Flight Costs**

To carry out a near space mission typically requires a \$60 weather balloon and \$100 worth of helium. An additional cost is the gasoline for the launch and chase crew. Including the driving to the launch site, possibly four hours of chase and recovery time, and driving home, chase crews may drive over 160 kilometers (100 miles). In all likelihood, the chase vehicle is capable of off-road driving and probably has poor gas mileage.

## **Time Cost**

Not all costs relate to money, the time spent planning, launching, and recovering a near space mission can be substantial. The launch crew will spend at least two hours prior to the launch preparing for the flight and making predictions. An hour or more of traveling to the launch site may be necessary, depending on wind conditions. To fill a balloon and launch the near spacecraft requires at a minimum of one hour. Three or four hours may be necessary to chase and recover the near spacecraft and its payload of BalloonSats. Then chase crews must drive home. All told, launch crews will spend at least nine hours in support of the mission.

Combining these costs together and dividing them among five BalloonSats, we see each BalloonSat requires approximately \$135 in cost, 1.5 hours of time, and a share of the risk that a \$300 near spacecraft could be lost. These costs and risks are acceptable, if, the BalloonSat has a high probability of functioning properly for the duration of the mission. Therefore, the Functional Test is designed to verify each BalloonSat is capable of collecting its data for the duration of a typical mission (pre-launch to touchdown).

### **4.2.2 Functional Testing Procedure**

- Program the datalogger and prep all experiments like cameras
- Load the BalloonSat with its batteries, programmed avionics, and experiments
- Start the BalloonSat and let it sit for three hours
- Review the data collected

#### **Pass Criteria**

- Did the experiments record data for the entire three hours?
- Did the experiments record the expected data?
- Did the camera have an unobstructed field of view?

## 4.3 THERMAL TESTING

The air temperature in near space can drop as low as -68 degrees C (-90 degrees F). That's a temperature that most items (snowmen being an exception) don't like.

### 4.3.1 Thermal Testing Background

Some electronics, like dataloggers, have minimum recommended temperatures. Levels for most industrial items range from -40 degrees C to +85 degrees C (-40 degrees F to 185 degrees F).

As the temperature of a material drops, so does its molecular activity. This is a factor for batteries, which are chemical devices that produce a voltage based on their internal chemical reactions. So as its temperature drops, its ability to produce voltage under a given load decreases. Therefore, batteries have minimum rated temperature. Going below this temperature risks the battery will fail to function.

**TABLE 4-1. Minimum Recommended Battery Temperatures**

<u>Battery Chemistry</u>	<u>Minimum Temperature</u>
Alkaline	-18 degrees C (0 degrees F)
NiCd/NiMH	-20 degrees C (-4 degrees F)
Lithium	-55 degrees C (-67 degrees F)

### 4.3.2 Thermal Testing Procedure

A thermal test requires a thermal test chamber. Therefore, construct the thermal test chamber (TTC) as explained in Appendix A.



**FIGURE 4-2. Loading a BalloonSat into a thermal test chamber.**

- Charge the chamber with dry ice and let it chill
- Measure the internal temperature and record
- Program one or more temperature sensors
- Load a temperature sensor into each BalloonSat
- Load the BalloonSats inside the chamber and close the lid
- Let the BalloonSats set for 30 minutes
- Remove them and download their temperature data
- Evaluate temperature data

#### **Pass Criteria**

- How fast did each BalloonSat cool
- How cold did each BalloonSat ultimately get



**Note:** Thirty minutes is probably long enough to let the thermal test chamber cool before beginning the test. More than one BalloonSat can fit inside the thermal test chamber, so prepare more than one datalogger. The slower a BalloonSat cools, the better. In addition, the warmer the BalloonSat remains at the end of the test, the better. Unless an item inside a BalloonSat is severely temperature sensitive, the thermal test is not necessary or sufficient reason to prohibit a BalloonSat from flying. However, each BalloonSat can receive a score based on the above criterion.

## 4.4 DROP TESTING

Landing can be a violent experience, even with a parachute. Therefore, it's important to verify that a BalloonSat will not break apart upon touchdown and lose its internal experiments.

### 4.4.1 Drop Testing Background

At touchdown, BalloonSats can descend at a speed of 16 kilometers per hour (kmph) or 10 miles per hour (mph). That's equal to 4.5 meters per second (m/s) or 14.7 feet per second (ft/s). We can simulate the parachute landing by dropping the BalloonSat. As the BalloonSat (or any other mass) accelerates under the force of gravity its speed increases according to the following formula.

$$\mathbf{v} = \mathbf{at}$$

This formula assumes that no forces, like air drag, act on the falling body. For our needs, this is an acceptable assumption. In this equation,  $\mathbf{v}$  is velocity (or speed in our case),  $\mathbf{a}$  is the acceleration of gravity ( $9.8 \text{ m/s}^2$  or  $32.2 \text{ ft/s}^2$ ), and  $\mathbf{t}$  is the time (in units of seconds). The calculated speed will be in units of m/s or ft/s.

Rearranging the equation, we can see that the time necessary to reach the touchdown speed of a parachute is given by,

$$\mathbf{t} = \mathbf{v/a}$$

Solving the above equation, we find the BalloonSat must fall for 0.5 seconds. The drop test is easier to perform if we know how high to drop the BalloonSat rather than for how long. The distance the BalloonSat will fall in a given time is given by the formula below.

$$d = \frac{1}{2} at^2$$

This formula also assumes no other forces are acting on the falling BalloonSat. Solving for distance (d), we find the BalloonSat falls 1.2 m (4.0 ft) in 0.5 seconds. However, we don't want a BalloonSat just to survive a drop at the predicted speed. We want it to survive the drop with some reserve. Unlike the aerospace industry, we cannot make multiple copies of the same flight article (BalloonSat) for testing. At the same time, we can't test the BalloonSat to destruction. The minimum landing speed for the drop test is an issue for the BalloonSat Program Manager to decide, however this chapter does recommend three options below.

Aside from the drop height and number of drops for each BalloonSat, the landing surface and BalloonSat orientation are two additional factors to consider for the drop test. Recovery normally occurs in open fields and rarely on roads. Therefore, an acceptable compromise between a hard floor and shag carpet must be found to drop the BalloonSat over. The attitude, or orientation, of the BalloonSat at recovery is unpredictable. That's because during the descent, BalloonSats may tangle with each other, may possibly tangle with the burst balloon, or travel horizontally during the descent.

#### 4.4.2 Drop Test Procedure



**FIGURE 4-3. A BalloonSat being readied for its drop test.**

- Load up the BalloonSat with its experiments and battery and close its hatch
- Lift each BalloonSat to the height selected by the BalloonSat Program Manager
- Orient the BalloonSat bottom down
- Drop each BalloonSat the same number of times

#### **Pass Criteria**

- Did the BalloonSat remain sealed
- Did the BalloonSat remain in one piece

**Note:** The drop test requires the use of a ladder. Do not use chairs for this test, as they aren't as safe. Always have a second person steady the ladder when someone climbs it for the drop test. Place a small rug below the ladder as the recovery zone for each drop test. Table 4-2 lists several recommended drop heights, based on landing speed criteria

**TABLE 4-2. Drop Heights**

<b><u>Descent Speed</u></b>	<b><u>50% faster</u></b>	<b><u>100% faster</u></b>
1.2 m (4.0 ft)	2.8 m (9.0 ft)	4.1 m (13.6 ft)

The number of times to drop each BalloonSat depends on the landing speed of the BalloonSat. One recommendation is to drop BalloonSats three times at descent speed, twice at a 50% faster, and only once at a 100% faster. Don't try to prevent the BalloonSat from tumbling.

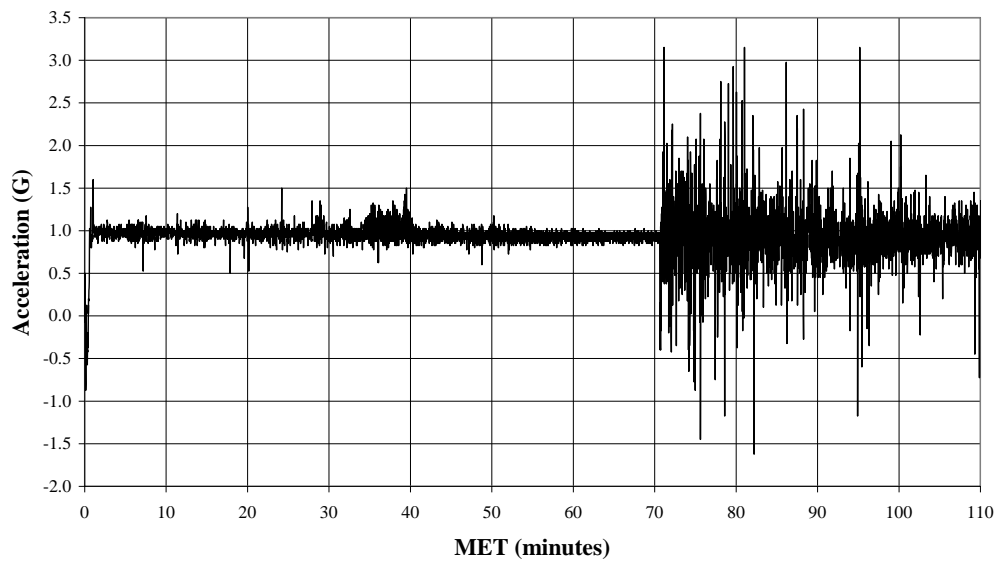
## **4.5 SHAKE TESTING**

The initial launch and subsequent descent of a BalloonSat is a time of rapid changes in motion in three dimensions. Since the BalloonSat is inaccessible after launch, the shaking it experiences at launch cannot shift the position of internal components in ways harmful to the completion of the mission. It's also preferred that motion during the descent doesn't shift the internal configuration of the BalloonSat either, as there may be important data collected during the descent.

### **4.5.1 Shake Test Background**

According to accelerometers carried on near space flights, momentary accelerations in excess of three g's are possible during the most violent part of the mission, balloon burst and the initial descent. However, for the majority of the ascent, accelerations tend to be below 0.25 g's.

## NearSys 07A Vertical Acceleration



**FIGURE 4-4. Typical acceleration of a near space flight.**

Figure 4-4 illustrates that for the majority of the mission, a BalloonSat doesn't experience much shaking. The first violent encounter a BalloonSat experiences is the launch. If its internal components shake loose or shift at this time, it's possible some of its experiments will fail to return proper data. A BalloonSat's most violent experience is balloon burst, which occurs at an altitude around 85,000 feet. If a BalloonSat breaks up at this altitude, its internal components will scatter over a wide region and are unlikely to be located again. Therefore, it is crucial that the BalloonSat crew test their creation for its ability to stand up to the rigors of the launch, balloon burst, and its initial descent.

### 4.5.2 Shake Test Procedure

The shake test is a two stage test of a BalloonSat.

- Load the BalloonSat with its contents
- Seal the BalloonSat hatch with rubber bands

- Rotate the BalloonSat rapidly about three perpendicular axes, one axis at a time

### **Pass Criteria**

- Were loose parts heard rattling around?

Second stage requires the use of a shake stick

- Load the BalloonSat with its contents
- Seal the BalloonSat hatch with rubber bands
- Load all items inside the BalloonSat
- Seal its hatch with rubber bands
- Pass the shake stick cords through the BalloonSat's suspension tubes
- Lock the BalloonSat onto the shake stick with split rings
- Climb the step ladder and wear eye and/or face protection
- Hold onto the step ladder and begin shaking the BalloonSat severely
- Shake each BalloonSat for the same length of time
- Remove the BalloonSat from the shake stick

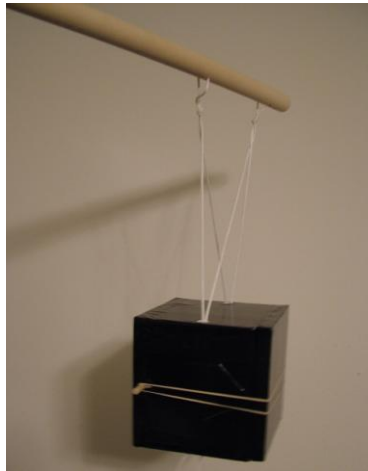
### **Pass Criteria**

- Gently shake the BalloonSat listening for the rattling of loose items
- Open the BalloonSat and inspect its interior

**Note:** The second stage of the shake test simulates the effects of balloon burst and initial descent on the BalloonSat. Shake the BalloonSat by snapping the shake stick cords, but don't batter the BalloonSat with the shake stick's wooden dowel. The BalloonSat Program Manager determines the minimum time the tester should shake the BalloonSat. However, five minutes of severe shaking should suffice. Safety glasses or face shield are required to perform the shake test on a BalloonSat.

## The Shake Stick

The shake stick is a long wooden dowel with two holes drilled through it. Position the holes about 15 cm (6 inches) apart near one end of the dowel. Pass two Spectra or nylon cords (about one meter or one yard long) through the holes and tie their centers together in an overhand knot with roughly equal lengths of cord hanging from the knots. Before passing and tying the cords, heat their cut ends to melt them so they do not fray. Tie small bearing swivels to the four ends of the dangling cords the free end of each cord in a doubled up, overhand knot. The cords now simulate the suspension lines that connect the BalloonSat to the near spacecraft. As in a near space mission, the cords pass through the BalloonSat's suspension tubes. A split ring links together the swivels at the end of the cords to prevent the BalloonSat from slipping off while being shaken.



**FIGURE 4-5. A BalloonSat undergoing a shake test.**

## 4.6 PREP TESTING

The available free time during a launch is limited, as are the available tools, and perhaps even a comfortable climate.

### **4.6.1 Prep Testing Background**

A weather balloon is not a structure capable of surviving moderate wind loads on the ground. In flight, it's a different matter, as a balloon is free to move with the wind, however, that's not the case on the ground while the launch team fills a balloon from a stationary filling station. When the winds blow too strongly, the balloon risks being blown into the ground or creating string burns in the hands of its wranglers.

As a result, the balloon filling normally takes place in early morning before surface winds have a chance to pick up. Since little time is available to the teams of each BalloonSat, it's important that they be able to prepare (prep) their BalloonSat rapidly.

In addition, the amount of specialty tools available at the launch site is limited. Therefore, a BalloonSat's design must allow its crew to prep with a minimal of tools. This is one reason that the BalloonSat Principia recommends designing BalloonSats with hatches closed with rubber bands.

It can be cold on the morning of a BalloonSat launch. If this is the case, then the BalloonSat design should allow gloved crews to prep it for launch.

### **4.6.2 Prep Testing Procedure**

- Configure each BalloonSat for the condition they will arrive to the launch site
- Layout any tools the BalloonSat team will need
- Call begin and start a stop watch at the same time
- Record the time needed to prep and close the BalloonSat

#### **Pass Criteria**

- Did the launch team prep and close out the BalloonSat within the allotted time?



**Note:** The battery is not usually loaded in the BalloonSat before, as it protects the battery from accidental discharge before the mission begins. No other members of the BalloonSat team are to communicate with the launch team during this test. The time limit for this test is flexible, and unless the prep time is excessive, this test is not justification to prevent a BalloonSat team from launching their project. Results from this test can identify launch crew that need practice prepping their BalloonSat. If the launch is to take place during cold weather, the launch team should demonstrate that most if not all of the checklist can be completed while wearing gloves.

#### **4.7 Test Conclusion**

These tests evaluate a BalloonSat's ability to survive the rigors of a near space flight. BalloonSats exceeding their maximum allowable weight, not functioning as designed, and suffering excessive damage during drops or shaking should be modified and retested. While tests like thermal and prep can be justification for modification, the tests are more effective as challenges for BalloonSat teams and useful for creating a score for each team.

## APPENDIX R

### Sample BalloonSat Reports

#### B.O.B. Final report

Our initial plan was pretty much to build the balloons sat and have it work, and well that was quite a bit harder than we thought it would be.

We researched things that would be useful to the balloon sat like older balloon sat projects and everything we can think of for the atmosphere. We did experiments on the atmosphere and the relative humidity. We also made posters before-hand to see what we might find in the atmosphere. We also practices out soldering on building a whooper alarm.

We built the box as a normal cubed shape but added shelves for each individual component so that nothing bounced around and or go un-hooked. We cut small holes in the Styrofoam to keep all the wires from moving around or getting tangled.

Although we had some difficulty on the building the box because of disagreement and arguing and some troubles getting the cords and circuit boards put on correctly we had a lot of fun.

Well we were disagreeing a lot and we were getting confused. And it was getting hard to work together as a group. We had some arguments along the way but we always found a way to get through the issues. We also had some issues with the circuit boards, like which way they went. Also having issues with the cords, honestly the cords were the hardest because they were going everywhere and we couldn't figure out how to keep them tamed. The cords finding out where they went was easy now controlling where they went, like when they were in place and in the box they would stick up and get in the way. The shelf was also an issue we encountered we wanted it to be removable but we didn't know how it could stay and make the flight without bouncing around.

We had some surprises with the end results and pictures because our light sensor ended up getting the oddest of data and the pictures were mostly a reflection of the camera itself, but in the end we figured it out. Our sensors readings had jumped around a lot because our box was accidentally put on its side and we got close to the top of the flight not to mention it was swinging a lot. And the pictures were mostly a reflection because we were doing infer-red pictures and there was too much light getting in the box.

We did have some difficulties with the data that was received after the flight. We spent many days figuring this out and we got told how to do it to where we didn't need Mr. Parry all the time, but without him we wouldn't have been able to figure it out at all by ourselves. The data was very confusing and we had a lot of issues understanding. We were pretty much doing

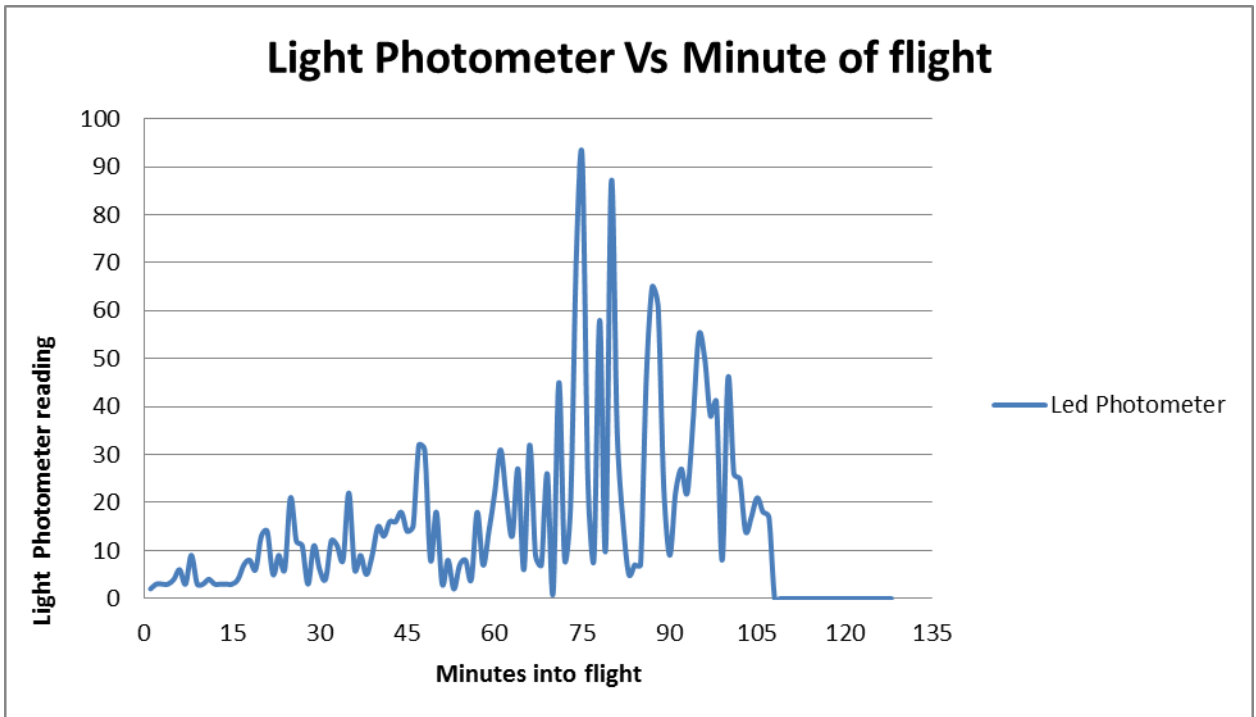
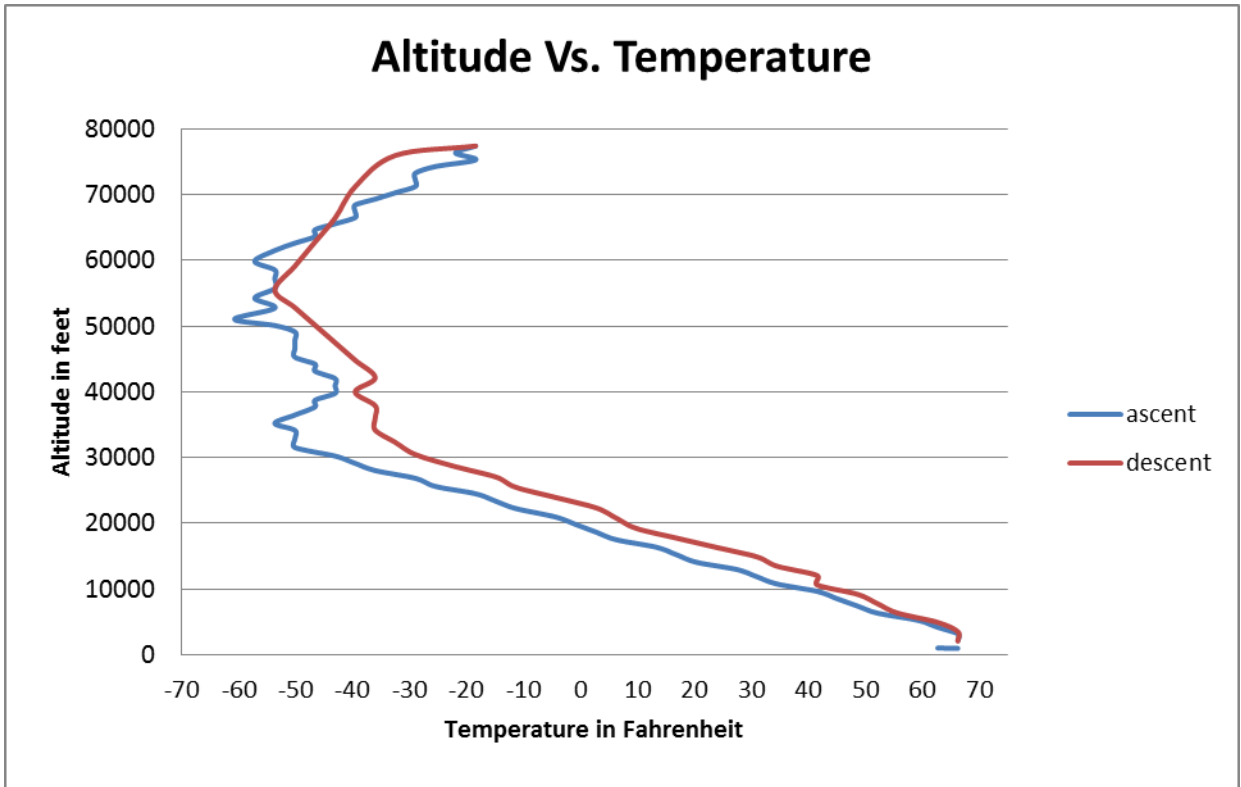
proportions we had to multiply a number then divide by the product. That's how we figured out the altitude. We had spent the whole hour figuring out the Outside Temp. Kelvin, Outside Temp, Fahrenheit etc. Figuring out the temperatures we used different formulas to figure out the different temperatures. It was difficult for us because we have never done of the things that we were using, we had some fun working on it, though

We didn't quite know how to change the data from the sensor reading to the actual data for temperature and light readings. We had to find our own formula to convert it from the sensor reading to temperature to Kelvin, then to Celsius, then to Fahrenheit. The light sensor is more difficult because we have no base light reading to compare to the amount of residual light in the atmosphere.

We had a light reading of 92 out of 255, which is like looking into the light of a projector from about 8 inches over it. To find this we had to do a test to find out how much light we get from different lengths above the projector while taking sensor readings. When we had the sensor right on the projector we only got a sensor reading of 23, but when we set the sensor in the point of highest focus we got a reading of 215. That was about a foot and a half from the projector.

The amount of light in the atmosphere was not as high as we expected it to be, but we also thought that it might go a little bit higher in the atmosphere. Another surprise was how much the temperature varied in the different levels of the atmosphere.

We would recommend to all students who will be working on their own balloon sat project that you try not to argue with the other people working on the box with you because it slows down the work and then you're behind, listen to your instructor because you will always do better and know what to do and have as much fun as you can. If you are trying to experiment with the amounts of heat and or cold that your box can withstand, make sure to test it with a left-over piece of Styrofoam or other materials that you may use. If taking an Infer-red picture make sure to test multiple shutter speeds and take pictures while moving to find the best amount of shutter speed it should be set to. Also make sure to cover all edges of the box so that no extra light can get into the box and cause a glare in your pictures.



Student comments:

K.H. My favorite thing about the balloon sat was being able to work on electrical stuff and working as a team.

D.T. I think I found two things equally enjoyable the soldering, and the programming and they were easy and a lot of fun.

D.H. My favorite thing about the balloon sat was the soldering because it was easy to do and fun watching people trying not to burn themselves.

K.S. My favorite thing during the balloon sat was putting the box together and working on the circuit boards and soldering.

A.P. What I like about the balloon sat is discovering what is going on in our earth's atmosphere and learning how to build a compartment by hand.

## Final Report on Flying Brave BalloonSat

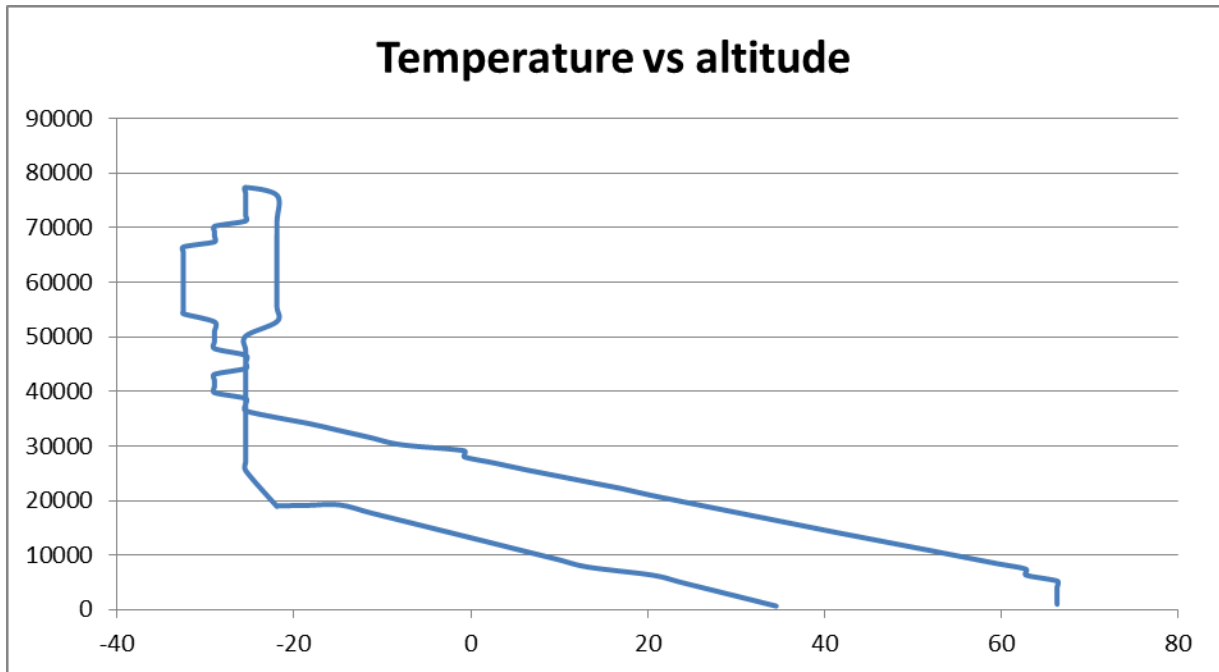
Our initial plan was to get it right, to not ruin the circuit boards, and to not burn each other with the soldering iron. The box had to be stabilized for the flight. It had to stand being thrown around, crash landing on the ground or in a tree, and/or hitting a tree.

Before we started the Balloon Sat one of our assignments was to research on the atmosphere. We later did a poster on what was in it, temperature changes, and how high it was in each layer. We had to draw things in each layer but also make it 3D. It was kind of hard looking for things to make it look 3D. We also had to incorporate Man-Made items.

There were many different designs that our group tried and none of them worked as well. Our group ended up making a simple box with a removable shelf. The sensor and the control center had to be hot glued down to prevent excessive movement. We also had to have a battery box within the main box part of the box so the battery wouldn't hit the camera during the flight.

Some difficulties that we faced were people not getting along. We sometimes left the battery plugged in so it died. We also had difficulties soldering the circuit boards and putting the bigger pieces in first. We got the wrong pic axe so that affected the sensor readings. The Sensors readings were not consistent. They gave us sensor readings that were impossible compared to the situation they were in. For example we had readings that were +90°F while working in a freezer.

The group would write notes to each other on pieces of scrap paper. It was hard to communicate in that way. We also had to talk to each other in the hall and other classes that we have together. A person not getting along with another person was another problem we had.



**Student comments:**

F.T.C -I liked putting it together and soldering all the pieces and being constructive.

P.R - I loved making designs for the Balloon Sat itself, even though we argued a lot.

B.P - My favorite thing about the Balloon Sat was being able to run all those tests. I felt like a real scientist when we were making this Balloon Sat.

C.M.T - My favorite thing about the BalloonSat was that we got out of doing our lessons and I liked soldering.

C.F - the thing I liked most is the soldering it was really fun.

R.C.T - my favorite part of the Balloon Sat project was looking at the final pictures.

C.M.T- I think the thing about building the Balloon Sat was, making the box and fitting everything in the box.

M.D.C - I liked all the soldering and putting the computer board together.

## Final Report Muni Mula

Our initial plan was to build the Balloon Sat so it would work properly and function correctly.

We researched the layers of the atmosphere and how high each layer was. We researched what was in each layer of the atmosphere. We did most of the research with posters. We experimented by soldering wires together

We drew the outline of the Balloon Sat and the inside. At first we just held the Balloon Sat together with our hands, and eventually with hot glue.

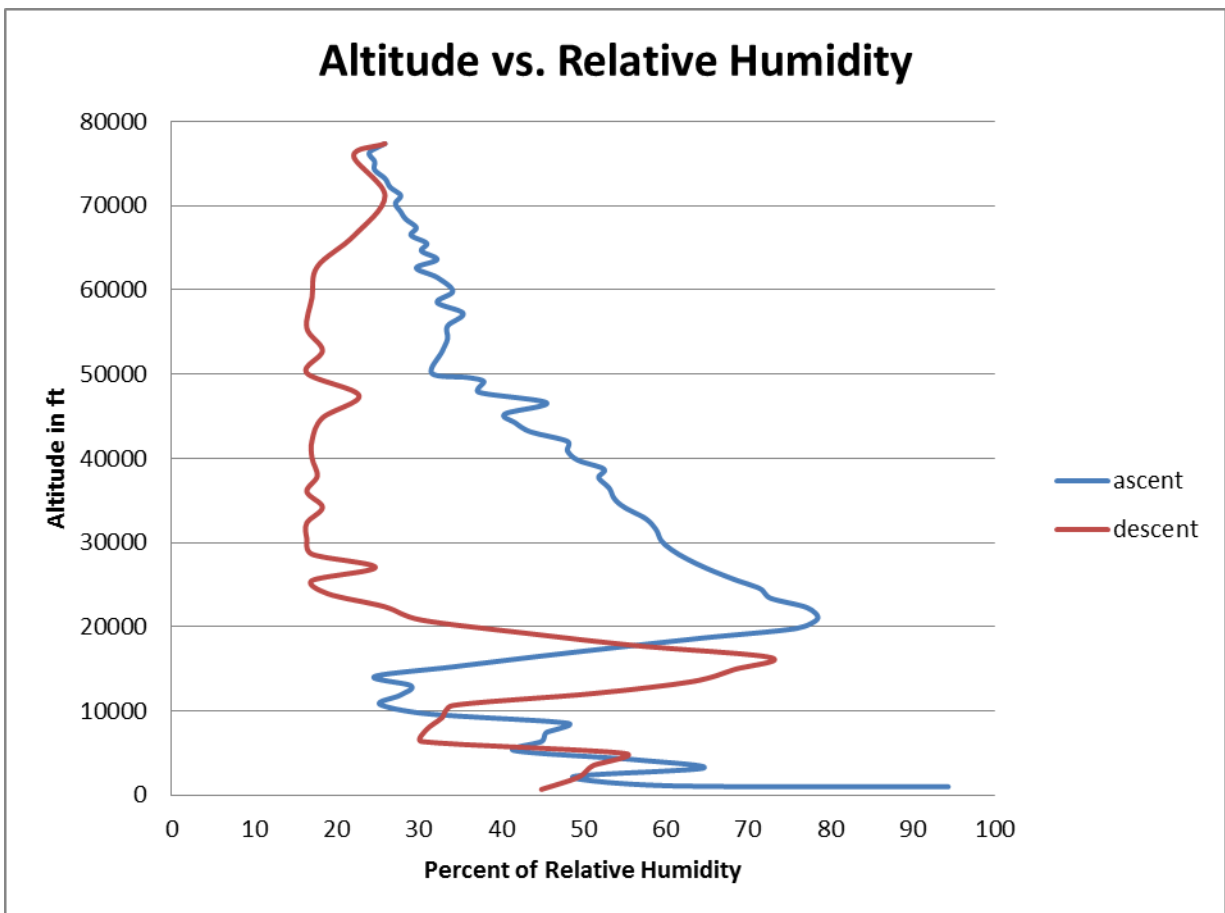
We couldn't fit the camera into the original place. We had issues with the soldering, because some of the holes that the wires went through were too big.

We were surprised how hard it was to solder. But for some it was not very hard. All you have to do is press the soldering wire to the base of the copper wire. Then press the soldering iron on the other side of the base of the copper wire. Then pull the soldering wire away then pull the soldering iron away from the board. I recommend following the instructions and be careful soldering.

Later we had to put the box together. We had a few problems getting the shelves to fit. But for the most part it was good. We had to design places for the boards and camera. When we started to build the frame of the box, the pieces were originally blue. After we finished building it we wrapped the box in black tape.



Then we did hot and cold tests. The cold test is when you put the box in the freezer and make sure everything would work properly. Once we got to the Heat test we experienced a few difficulties with the box, because the tape and part of the box melted.



**Student comments:**

A.S. ~“I think the best thing about doing the balloon satellite was the pictures”

J.L. ~“My favorite thing when we were working on the balloon sat was putting the wires together correctly and building the balloon sat box.”

M.S. ~ “My favorite part was soldering the wires to the circuit board.”

C.G. ~ “My favorite thing about the balloon sat is building the box”

T.D. ~ “My favorite thing about the balloon sat is that you got to put all the circuit board stuff together and soldering it all.”

B.G. ~ “I liked most about the entire whole balloon sat project is looking at the pictures and seeing the earth and seeing the sky turn from blue to black”