

Marquette University
e-Publications@Marquette

Mechanical Engineering Faculty Research and
Publications

Mechanical Engineering, Department of

6-15-2014

Helicopters as a Theme in a Machine Design Course

Devin Turner
Marquette University

Mark L. Nagurka
Marquette University, mark.nagurka@marquette.edu

Published version. Published as a part of *2014 ASEE Annual Conference & Exposition, Indianapolis, Indiana*. June 15-18, 2014. [Permalink](#). © 2014 American Society for Engineering Education. Used with permission.

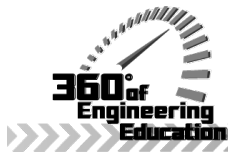

Helicopters as a Theme in a Machine Design Course

Mr. Devin Turner, Marquette University

DEVIN TURNER is a senior mechanical engineering student at Marquette University. He is president of the Marquette American Society of Mechanical Engineers and a member of the Student Advisory Board to the Department Chair. His professional experience includes working for the Space Shuttle Program at NASA Kennedy Space Center, UTC Aerospace Systems, Gulfstream Aerospace and Sikorsky Aircraft. He holds a private pilot license and has training in helicopters as well.

Dr. Mark Nagurka, Marquette University

MARK NAGURKA, Ph.D. is an Associate Professor of Mechanical and Biomedical Engineering and Lafferty Professor of Engineering Pedagogy at Marquette University. He received his B.S. and M.S. in Mechanical Engineering and Applied Mechanics from U.of Pennsylvania and a Ph.D. in Mechanical Engineering from M.I.T. He taught at Carnegie Mellon before joining Marquette. His professional interests are in the design of mechanical and electromechanical systems and in engineering education. He is a registered Professional Engineer in Wisconsin and Pennsylvania, a Fellow of the American Society of Mechanical Engineers (ASME), and a former Fulbright Scholar.

Helicopters as a Theme in a Machine Design Course

Abstract

The idea proposed here is to study helicopters and their components throughout a machine design course as a theme to teach students about different mechanical elements. A helicopter is an ideal system to exemplify the concepts taught in the course since all aspects of machine design are encapsulated in its design. Furthermore, a helicopter deeply pushes the limits of safety; the price of failure of one or more components or of the overall system is high (human fatality). This suggests large factors of safety in the design, but there is an inherent tradeoff. If factors of safety are too large, component designs do not satisfy weight constraints for flight.

For each topic of the course, the connection to helicopters is presented and helicopter design challenges are posed. For example, the shafts and gearboxes that transfer power from the high-speed turbine engines to the lower speed rotors can be used to teach students about shaft sizing (bending, safety, etc.), bearing sizing and placement, and principles of gearbox design. (In the standard helicopter configuration, two turbine jet engines drive a main rotor and a tail rotor, and the pilot controls are linked to both rotors for handling of the aircraft.) Students quickly discover that due to size constraints planetary gears are used in the gearbox to achieve the speed reduction between the engines and the main rotor.

In this paper, we describe the connection between the topics of a typical machine design course and helicopters and their components. The motivation for selecting a theme system in teaching machine design is to enhance learning and bring more excitement to the topics in a course that is generally considered very challenging. Most students are not familiar with the design and components of helicopters, yet are fascinated with their operation making it an attractive topic. The approach of using helicopters as a theme in a machine design course is being implemented and evaluated.

Introduction

A machine design course is required in most undergraduate mechanical engineering curricula. This course typically covers an introduction to mechanical engineering design, a review of materials engineering, a review of mechanics of materials (shear force and bending moment diagrams, stress and strain analysis, deflection and stiffness analysis of beams, etc.), models for failure from static and variable loading (fatigue failure), and then presents (in no consistent order) the design of specific mechanical elements: shafts, fasteners, springs, bearings, gears, flexible elements (such as belts, chain, and wire rope), clutches, brakes, couplings, etc.

For some topics in machine design it is not possible to develop analytical models from first principles, as is done in fluid mechanics or thermodynamics. The approach is more "experience" based and is not especially motivating for students, who view the constants in some "equations" as "fudge factors" that must be accepted on blind faith and somehow work to get an approximate answer. Although the empirical-based methods are part of conventional practice and work for specific machine design topics, they can be unsatisfying, arbitrary, and not meaningful unless tied to real-world problems.

To add another dimension to the course content and inspire students to see a real-world application of machine design concepts, the helicopter was selected as a theme case-study discussed throughout the course. The helicopter is well suited to serve as a case-study as it incorpo-

rates all topics of machine design that are taught, and its unique capability of vertical flight is exciting for many students. To integrate the theme into the course, the textbook and topics of the course remain the same and a portion of each lecture topic is used to explain how it applies to helicopters. Helicopter design and components are then the background for sample problems, class discussion, and safety analysis. Questions about component design within constraints are addressed in the context of helicopters. For example, the main rotor bearing can be used as an example of a bearing application. Students can be asked what types of bearings could be used and challenged in a discussion of how bearings could be designed to minimize weight and maximize fatigue life.

Topics and Connection to Helicopters

In the beginning of the course, students are introduced to types of helicopters, their basic principles, and the main systems they use to accomplish flight. Then, as new topics are covered throughout the course they are related to the design of helicopters. The topics of a machine design course and their connection to helicopters are presented below.

1. Introduction to Helicopter Systems

This topic serves as an explanation of why helicopter systems are used as a theme throughout the course, and gives an overview of the principles of helicopter flight and the basic systems that are required for a functioning helicopter. Four forces are present in a stable flight condition, as depicted in Figure 1. When the lift generated by the helicopter main rotors is greater than the weight, flight is achieved. Once airborne, the helicopter main rotors produce thrust, which (if greater than the drag force) results in movement.

Helicopters require four basic systems to achieve flight. The four systems are identified in Figure 2. Two of the systems - an engine and controls - are found in other vehicles (cars, boats, trains, etc.), but the function of helicopters necessitates special design considerations that make the other two systems - the main rotor and anti-torque system - unique.

- Engine. All helicopters require a "prime mover". Internal combustion engines were used in the early designs and are still used in many smaller helicopters (such as Robinson helicopters). For higher performance applications, such as heavy-lifting or military needs, turbine jet engines (generally two) are used. Recently, in an effort to reduce emissions, an electrically powered passenger-carrying helicopter was tested successfully.¹
- Main Rotor. The main rotor is a rotating wing that provides the lift to allow the helicopter to fly. By using engine power to rotate the blades, lift is produced. Flight is achieved once the lift force exceeds the weight of the helicopter.
- Anti-Torque System. The helicopter achieves flight by rotation of the main rotor. In flight the helicopter is not grounded, and a system is needed to compensate for the torque created by the main rotor to prevent the body of the helicopter from spinning in the opposite direction. This "anti-torque" system is accomplished using a smaller rotor (propeller) that creates a moment that counteracts the torque of the main rotor, as shown in Figure 3. The tail rotor is powered by the same engines that power the main rotor.
- Controls. The control systems in helicopters are complex. Due to the rotational dynamics of the system, many factors including torque and especially gyroscopic effects must be taken

into account in the pilot/machine interface. Helicopters include five main controls: engine throttle, collective pitch control, cyclic pitch control, and two anti-torque/rudder pedals, as shown in Figure 4. With these controls the pilot can provide input to all degrees-of-freedom of movement of the helicopter. Although some of the newest helicopters have computerized control capabilities, almost all helicopters currently in service use direct mechanical linkages between the pilot flight controls and the rotor blades.

These four systems present critical design challenges that are solved using machine design concepts covered in the course.

2. Stiffness and Deflection

Stiffness and deflection are pertinent to almost every aspect of helicopter design. These concepts are connected to helicopters through many examples, including that of the main rotor blades of the helicopter where stiffness is most evident. Since the blades spin during normal operation, they must be designed to minimize axial deflection due to the tension created by the centrifugal loading and to minimize bending under their own weight due to static loading. A helicopter blade can be modeled as a fixed-free cantilever beam. Students can solve for the deflection of the blade under tensile loading and distributed loading, as shown in Figure 5. A case-study of the Sikorsky S-76 blade tip failure is also introduced. Students then discuss what they have learned about stiffness and deflection as it relates to design of components and how the S-76 design could be modified to minimize the risk of failure.

3. Loads and Stress

Stress and load path design is a critical aspect in any machine. This course topic is connected to helicopters using a case-study of the landing gear design of the UH-60 Blackhawk helicopter. This design is unique in its ability to resist impacts and direct crash loads around the cockpit and passenger compartment of the helicopter. Students are shown a comparison of the Blackhawk landing gear design with other landing gear designs and are prompted to discuss the load paths of the designs. Students can use basic calculations to approximate the forces applied to the structure during a crash and then review finite element analysis results that model the performance of the designs under impact loading to validate their calculations.

4. Shafts

Shafts are a central aspect of helicopters and are "flight critical" components, meaning that failure may result in loss of control and precipitate a crash. There are many shafts present in the drive train of a helicopter to transfer power from the engines to the main rotor and then from the tail rotor gearbox to the tail (anti-torque) rotor (Figure 6). The tail rotor is typically a long distance from the main rotor and must operate at speeds of 4,000 - 8,000 rpm, presenting multiple design challenges. Students are prompted to discuss the challenges of torque transmission over a long distance at high speed. In a class problem students solve for the natural frequencies of helicopter shafts of different lengths, and investigate the design considerations that would influence the shaft geometry choices. An alternate helicopter design accomplishes the anti-torque function without the use of a tail rotor (Figure 7). Students are asked to identify potential advantages and disadvantages compared to a conventional design.

5. Gears

Gearboxes are "flight critical" components of helicopters. They generally are compact and use trains that include different types of gears (bevel, spur, helical, and planetary). An example of a gearbox used in helicopter drive trains is the Eurocopter helicopter gearbox, shown in Figure 8. Students are challenged with questions about the gearbox design, such as why certain gear types were selected and how the ratios were chosen to minimize space. A class problem is to find ratios for the necessary speed reductions in a helicopter drive train, and then design the gearbox to accomplish it. Many different solutions can be reached and the students can then discuss the merits of different configurations. A case-study of the Sikorsky S-92 helicopter that crashed due to sudden loss of gearbox oil and failure of the main engine gearbox is also presented. Safety in gearbox design is discussed and post-crash photos of bevel gears from the failed gearbox are analyzed (Figure 9).

6. Flexible Components

Flexible components, such as belts, chains and wire rope, are a central topic in the machine design course. Flexible components are most commonly present in helicopters as wire rope in control linkages (Figure 4) connecting the pilot controls to the helicopter rotors. Some helicopter designs use belt drives in the drive train as well. Both of these applications are presented to students. This prompts discussion of the types and number of belts selected for the drive train (multiple V belts) and the advantages and disadvantages of using belt drives in place of gears to transfer power between components.

7. Bearings

Bearings are "flight critical" components of helicopters. Helicopters rely on bearings to support many rotating components necessary to achieve flight. The most important bearings are the main rotor bearings. They are comprised of large ball bearing assemblies that provide the interface between the stationary helicopter fuselage and the shaft of the rotating main blades. A case-study is used to introduce the main types of bearings and the design considerations in selecting bearings. Students are asked why ball bearings are used for the main rotor bearings and what parts experience the most stress or fatigue. A case-study of a crash caused by failure of the main rotor bearing is also presented. In this specific incident the failure was caused by incorrect tolerancing of the bearing balls and resulted in fatalities of all on-board.² Students are prompted to discuss other potential areas of concern in bearings used in helicopters.

8. Clutches and Brakes

Both clutches and brakes are used in helicopters as components of the main rotor system. Regardless of the engine used (piston engine, turbine engine), a clutch is needed between the drive train shaft from the engine and the main rotor so that they can be decoupled. The most important function of the clutch is to allow the pilot to disengage the rotor from the engine in the event of an engine failure. This allows the rotor blades to rotate freely and not "freeze" if the engine drive shaft becomes stuck. Once free, the rotor blades will continue to rotate as the inertia of the helicopter keeps it moving forward. Another function of the clutch is to allow the pilot to start and run the engine without the added load (and potential hazard) of spinning the main rotor blades. This is especially useful in helicopters with jet turbine engines as their combustion process requires the engine to "spin up" before it becomes efficient.

Brakes are used in helicopters to slow down the speed of the main rotor. After flight, the clutch is disengaged and the engine(s) are shut down. However, the main rotor continues to spin at the engine idle speed until parasitic losses and air resistance slow it to a stop. Because helicopters are designed to have as little parasitic losses as possible, this could take a very long time and reduces the operational utility of the helicopter. As such, there is a “main rotor brake” in helicopters that acts like brakes on a car and allows the pilot to quickly stop the blades from spinning after the engine has been shut down.

9. Fasteners

The connection of fasteners to helicopters is presented with a discussion of rivets and locking bolts that are commonly used in aerospace applications. Due to the high vibration environment of a helicopter, all fasteners must be designed to resist fatigue and vibration, leading to the widespread use of bolts with pre-load and locking features. Rivets are commonly used in aerospace applications to join pieces of fuselage due to their resistance to shear as well as their ability to accommodate effects of temperature change and vibration. Basic principles of rivets/locking feature design are presented and students are prompted to discuss other applications of fasteners, grading of fasteners, as well as design aspects such as fatigue that could affect safety.

10. Springs

Springs and spring design are topics covered in a machine design course and there are several connections to helicopters. The concept of modeling structural elements of the aircraft as springs is discussed (it is related to the loads and stress section). The spring used in the main rotor brake assembly of the Robinson R22 helicopter is used to illustrate the process of sizing and selecting a spring for a given application. Diagrams from the maintenance manual are presented and students are prompted to discuss design considerations (size, stiffness, material, etc.) that need to be taken into account in selecting the spring. Catalog pages from suppliers are then shown and students can compare their choices with the the spring used in the helicopter.

11. Lubrication

Many different lubricants are used in helicopters and the attributes and applications of different types are discussed. Due to the multitude of rotating components, such as engines, shafts, and components of control systems, different types of lubricants are required to increase efficiency, fatigue life and performance of components in the helicopter. Lubrication systems are a failure-critical component of helicopters; the bearings and gearboxes that enable the rotor systems to turn are heavily lubricated. In the aerospace industry, lubricants typically must satisfy MIL-SPECs or Military Specifications. These standards, set by the U.S. government, include extensive information about material properties, storage, application procedures, and limitations. In this connection to helicopter design students are introduced to the basic concepts of MIL-SPECs. (Though they are termed Military Specifications they are not classified, are publicly available, and widely used in many industries.) The lubricant used in the Robinson R44 is presented as an example along with the relevant material properties and MIL-SPEC.

The operating manuals of helicopters (especially high performance and military aircraft) give specifications for “dry time” or operating time after loss of lubrication. This design specification, mandated by the military branches as well as the FAA, requires the helicopter manufacturers to design the bearings and gearboxes to have a minimum operational life (typically about 20 min-

utes) after loss of gearbox oil. This is a relatively challenging engineering design constraint as the components operate at relatively high speeds and stresses. Despite the regulations and efforts to produce robust designs, oil loss can still lead to catastrophic failures. A case-study investigates the events of a Eurocopter that had to make an emergency landing at sea due to loss of main gearbox oil.³

Status

The teaching of a machine design course using the helicopter system as a theme is being implemented to help motivate student learning, foster interest in the topics, and make the material more alive. In the Fall 2013, case studies and example problems were developed and support materials, including movies, photographs, diagrams, and helicopter manuals, were collected. The approach is being tested in the Spring 2014 in a required 4-credit junior-level mechanical engineering course “Design of Machine Elements” at Marquette University. The course has 3 hours of lecture and 2 hours of laboratory each week. In the last several years new laboratory experiments that promote discovery learning have been created for this course. A description of Marquette University's Machine Design Laboratory and experiments developed for the course has been reported at last year's ASEE Conference.⁴

Throughout the course, students have opportunities to submit feedback comments and to respond to questionnaires specifically addressing the pedagogical value of the helicopter theme. In a voluntary survey of 75 students, 49 responded with significant input; 95% of these students endorsed the idea and offered positive comments about the use of helicopters as a theme in the course. Overall there was strong reception to the approach. Specific comments included:

- I definitely endorse the use of the helicopter components as a way to connect the things we are learning to real world applications.*
- It is awesome being able to relate the things that I've learned not only in machine elements, but past classes like mechanics of materials, to helicopters. It all seems to make more sense in the way they are able to work, so I get a deeper understanding.*
- Discussing helicopters and their components is a great way for the topics we are covering in class to come alive. It offers us another window in topics like stress and strain, and does so in a way that is interesting and very realistic.*
- Any chance to relate real life engineering practices to what is being studied in the class is beneficial to everyone. In this case, helicopters fit the bill quite well.*
- The theme approach is effective and should definitely be part of the class curriculum.*
- Studying helicopters in our course in order to teach us about the different mechanical elements is a great idea. It really opened my mind and gave me a different mechanical vision of helicopters and all the mechanical analyses that go into their design. I was able to see the stress distribution along the wing and it actually made sense.*

Other survey questions focused on the connection between the helicopter theme and student motivation for learning, influence on the interest in the topics, and/or appreciation for the material. Student responses included:

- The discussion of the helicopter definitely motivates my learning, because as we learn more I am curious as to how it could be applied to different components on the helicopter. Further-*

more, it helps to see how things we learn in class apply to the real world, and that definitely makes the material come alive because it is less cut and dry.

- Real world application is very important for a smoother transition to the professional world. The helicopter lectures have made this real and enhanced my interest in proper design to create a better, safer product. My favorite topic so far was how the directional loading was important on a crash landing for the Blackhawk Helicopter. That brought the topic closer to me because of the potential to save lives after a crash in a helicopter. This crash-focused design concern forced me to think about where this is applied in other areas, such as crumple zones in cars.*
- Being able to relate the material from class to actual systems is an invaluable tool for my understanding.*
- The helicopter discussions help bring various topics to life. The visualization of the topics in the helicopter application push me to want to understand the topics covered in class as they are used in all mechanical systems.*
- The discussion of helicopters has helped bridge the gap between classroom learning and real-world applications.*
- I am able to visualize homework problems easier by thinking of how they would translate to the helicopter.*
- Learning about helicopters has encouraged me to think about other real world systems. By learning how to model certain aspects of a helicopter and use the equations and knowledge we draw from class to analyze it, it encourages me to think about other systems I would be capable of analyzing with my new found knowledge. I think this is the whole point of engineering, which is to be able to effectively use what we learn in class in the real world.*

Students were also asked how the theme approach could be made more effective and whether there is another approach - or a different theme system - they recommend. Responses included:

- I think that no matter what the subject is (helicopters, planes, cars, ships, etc), as long as we talk about real life objects that we can relate to, it is easier and more fun to learn.*
- Helicopters seem to have elements of just about everything we are studying, so it makes sense to keep the theme common, rather than jumping around between other fields/projects.*
- It would be more effective if students could really design a mini helicopter. It would help students understand how each element or subsystem works with each other.*
- Too often teachers don't provide meaningful applications of how to connect textbook material to real life. I don't think that is an issue at all in this class.*

Based on student feedback, the goals of implementing the helicopter theme as a means to increase interest in the material and encourage students to see the real-world applications of the course content appear to have been met. Formative assessment will continue throughout the course.

Conclusion

This paper describes the details of using helicopters as a consistent theme to provide a real-world connection to concepts in a machine design course. The motivation for adding this theme system to the course is to inspire students to think more deeply about applications of the course topics. By this approach students will see real-world examples of the topics, be exposed to additional detailed information related to the topics, and face design challenges based on an interesting physical system. The intent is to deepen critical thinking skills of students in applying the information presented in the course.

While this approach gives students a basic understanding of helicopter principles, the goal of using helicopters as a theme in the machine design course is to generate excitement for the material, add depth of understanding, and reinforce safety realities (mechanical failures in helicopters often result in fatalities). Furthermore, it is another attempt to transform the static environment of the classroom and make the course content more applicable to the students. Based on student feedback the approach is well received and accomplishes the goal of increasing student engagement and adding real life connections to the topics of machine design.

References

1. "Firefly™ Technology Demonstrator." *Firefly Technology Demonstrator*. N.p., n.d. Web. 02 Jan. 2014.
2. Zielbauer, Paul. "Sikorsky Supplier Settles Case Arising From Helicopter Crash." *The New York Times*. 11 Apr. 2001. Web. 02 Jan. 2014.
3. "Aviation Investigation Report A09A0016." *Government of Canada, Transportation Safety Board of Canada*. N.p., n.d. Web. 02 Jan. 2014.
4. Nagurka, M. and Rodriguez-Anton, F., 2013, "Discovery Learning Experiments in a New Machine Design Laboratory," 2013 ASEE Annual Conference, Atlanta, GA, June 23-26.

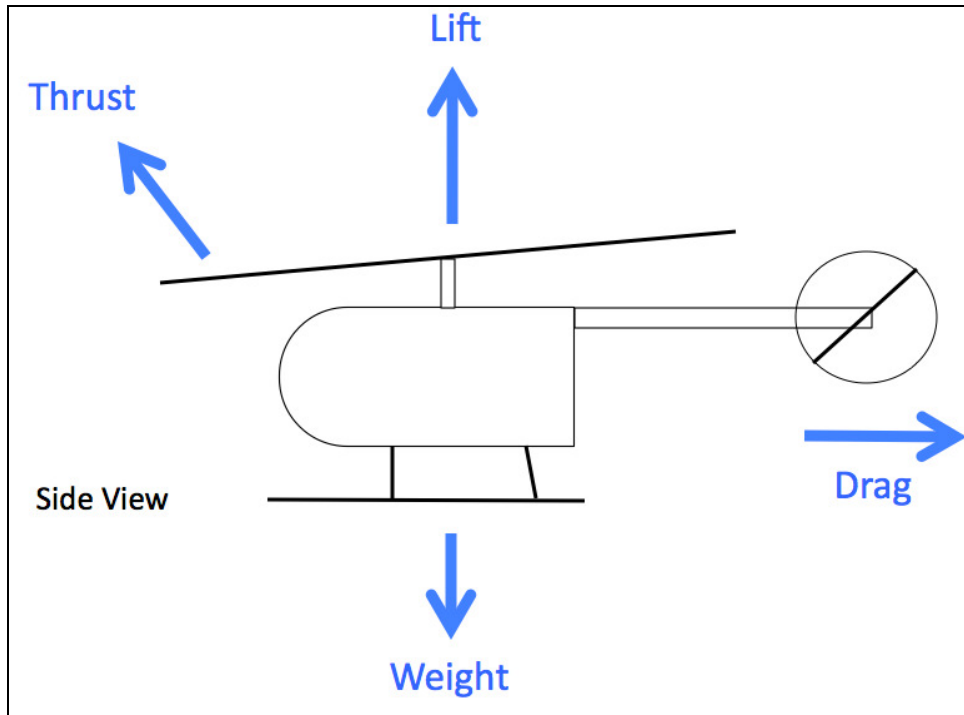

Figure 1. Forces Acting on Helicopter in Flight

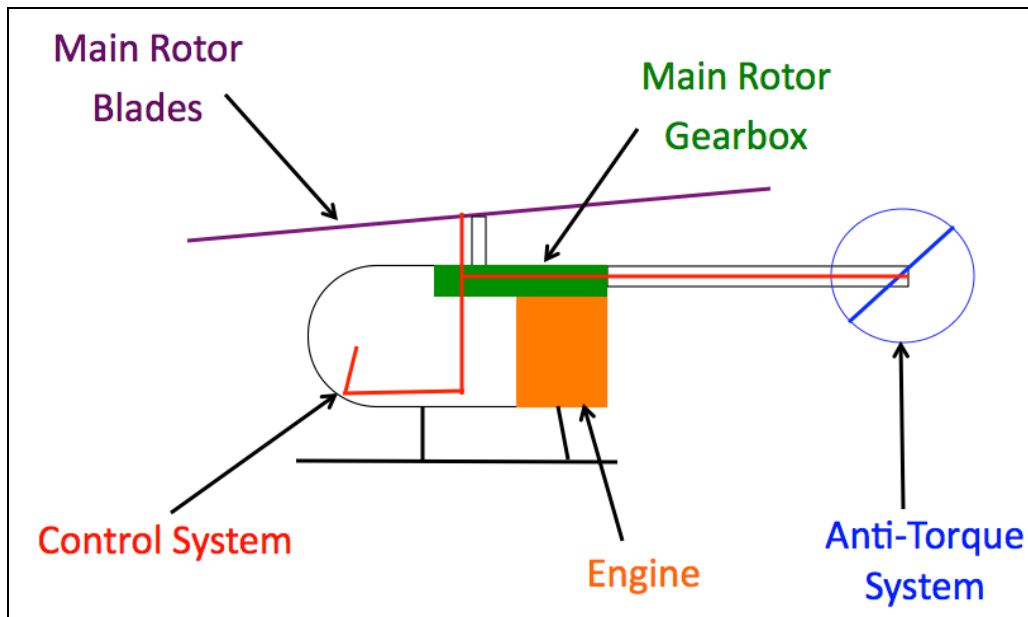

Figure 2. Main Helicopter Subsystems

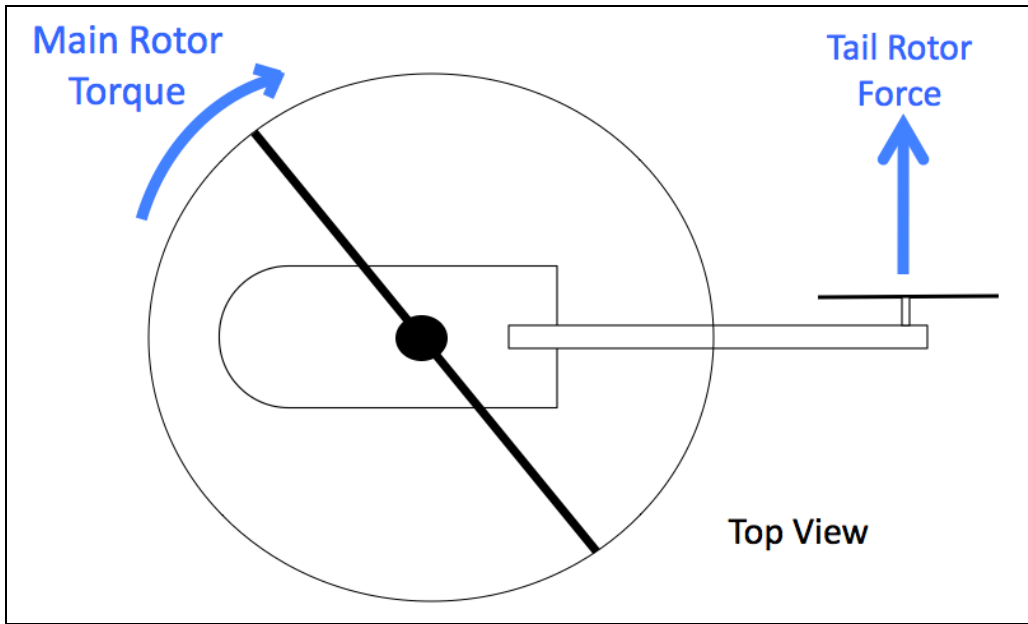

Figure 3. Helicopter Tail Rotor Creates Anti-torque

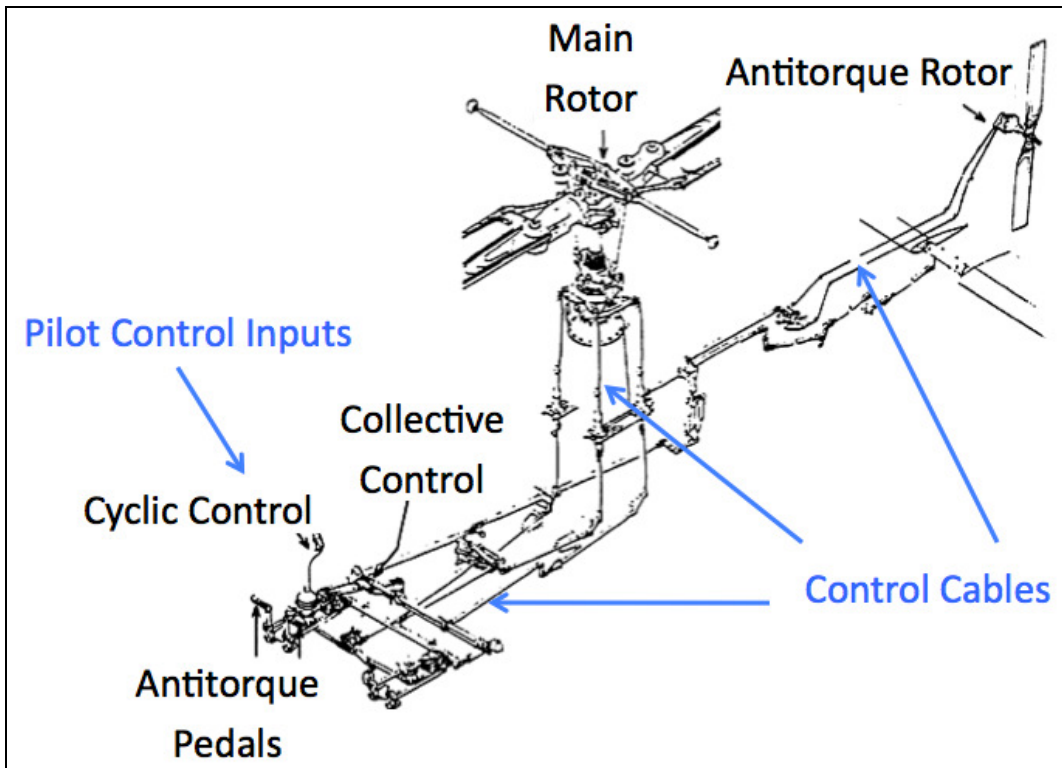

Figure 4. Helicopter Control: Inputs and Cables

<http://www.globalsecurity.org/military/library/policy/army/accp/al0966/le3.htm>

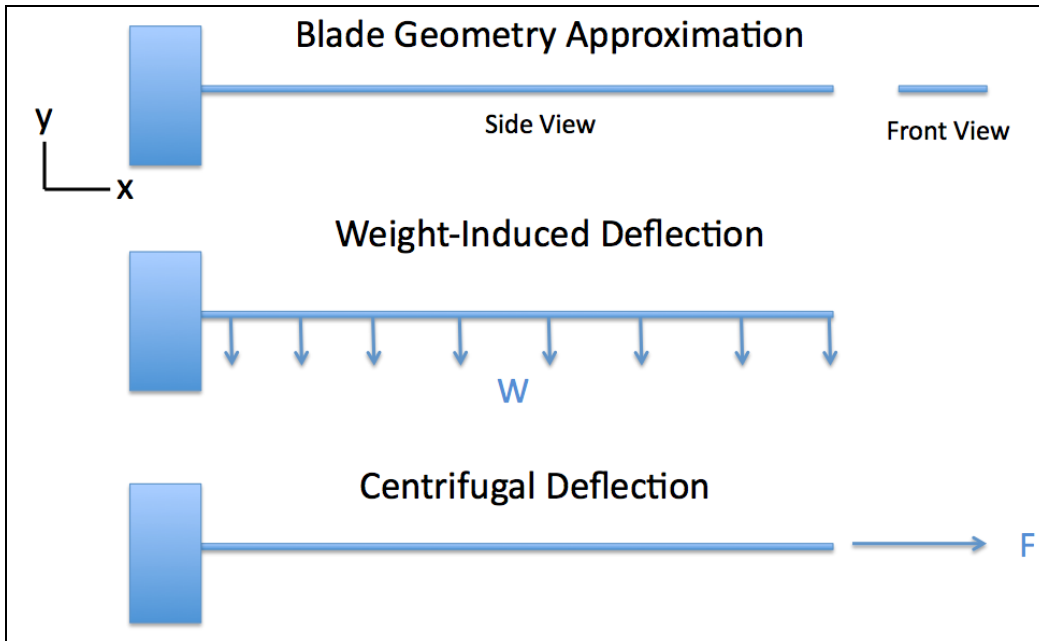

Figure 5. Modeling a Helicopter Rotor Blade as a Cantilever Beam
<http://www.flightlinearts.com/Portals/0/images/Portfolio/SikorskyUH-60M.jpg>

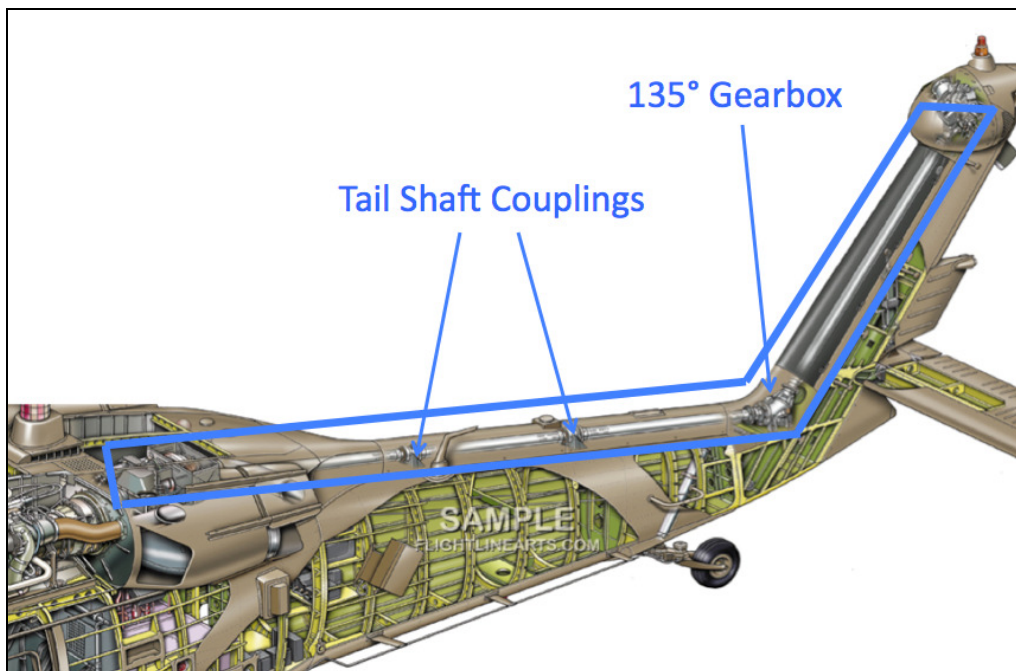

Figure 6. Shafts to Helicopter Tail Rotor
<http://www.flightlinearts.com/Portals/0/images/Portfolio/SikorskyUH-60M.jpg>



Figure 7. Shaftless Anti-torque System
<http://jetav.com/md-520n-specifications/>

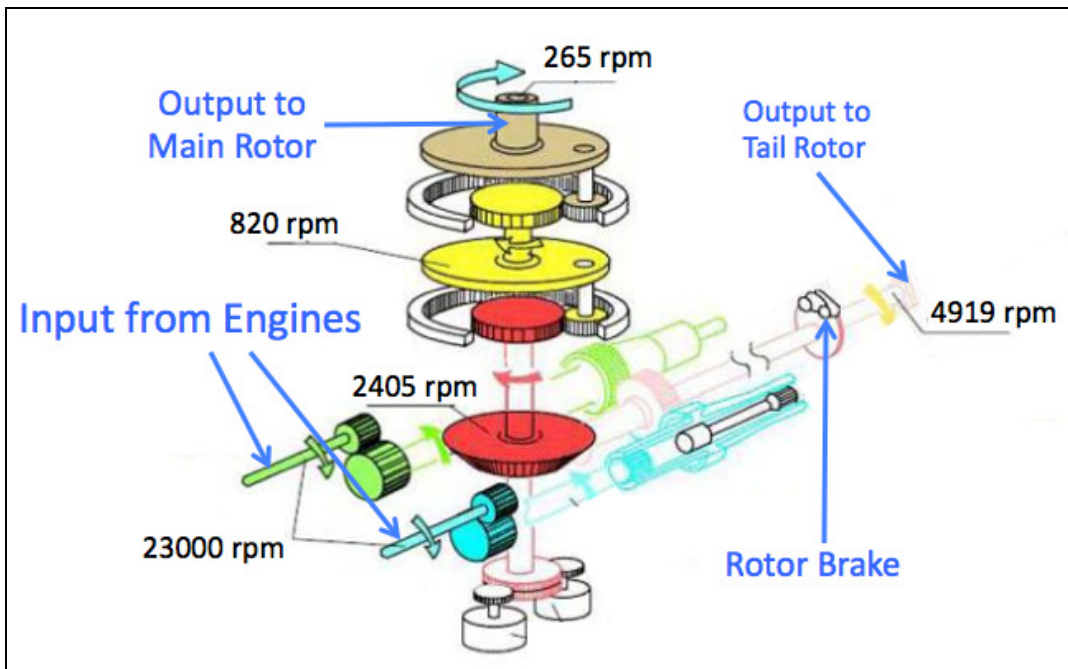

Figure 8. Eurocopter Gearbox Diagram
<http://isambardkingdom.com/?p=559>



Figure 9. Failed Gear Comparison
http://www.flightglobal.com/blogs/as-the-croft-flies/2009/06/feds_sikorsky_too_little_too_late_on_cougar_s-92_crash/