

## Worcester Polytechnic Institute Digital WPI

---

Major Qualifying Projects (All Years)

Major Qualifying Projects

---

April 2019

# Ultrasound Orientation Sensor

Angelica Cornelia Pollard-Knight  
*Worcester Polytechnic Institute*

Franck J. Coly  
*Worcester Polytechnic Institute*

Jada A. Plummer  
*Worcester Polytechnic Institute*

Justin Korn  
*Worcester Polytechnic Institute*

Follow this and additional works at: <https://digitalcommons.wpi.edu/mqp-all>

---

### Repository Citation

Pollard-Knight, A. C., Coly, F. J., Plummer, J. A., & Korn, J. (2019). *Ultrasound Orientation Sensor*. Retrieved from <https://digitalcommons.wpi.edu/mqp-all/7114>

This Unrestricted is brought to you for free and open access by the Major Qualifying Projects at Digital WPI. It has been accepted for inclusion in Major Qualifying Projects (All Years) by an authorized administrator of Digital WPI. For more information, please contact [digitalwpi@wpi.edu](mailto:digitalwpi@wpi.edu).



**Project #: KL1-ABPE**

# **Ultrasound Orientation Sensor**

**A Major Qualifying Project Submitted to the Faculty of  
Worcester Polytechnic Institute  
in partial fulfillment of the requirements for the  
Degree in Bachelor of Science**

**By**

---

---

**Franck Coly**

---

---

**Justin Korn**

---

---

**Angelica Pollard-Knight**

---

---

**Jada Plummer**

**Date: April 25, 2019**

**Advised by:**

---

---

**Dr. Kwonmoo Lee, WPI**

---

---

**Dr. Khashayar Rafatzand, Umass Memorial Hospital**

# Table of Contents

<b>List of Figures</b>	<b>4</b>
<b>List of Tables</b>	<b>6</b>
<b>Abstract</b>	<b>7</b>
<b>Acknowledgements</b>	<b>8</b>
<b>Authorship</b>	<b>9</b>
<b>All team members equally participated in the writing of this report.</b>	<b>9</b>
<b>Chapter 1: Introduction</b>	<b>10</b>
<b>Chapter 2: Literature Review</b>	<b>15</b>
2.1 Ultrasound	15
2.1.1 What is Ultrasound	15
2.1.2 Importance of this field	17
2.2.1 The use of ultrasounds without position sensors	17
2.2.2 Current Methods of Improving User Accuracy	18
2.2.3 Common errors in sonography	18
2.2.4 Effect of Orientation on Ultrasound Image Measurements	20
2.3 Current Technology and Their Limitations	22
2.3.1 Embedded Sensor in Ultrasound Probe	22
2.3.2 Tactile Sensor	23
2.3.3 Ultrasonic Sensor in Laparoscopic Instruments	25
2.4 Position Sensors	26
2.4.1 Optical Sensors	26
2.4.2 Accelerometers	26
2.4.3 Gyroscopes	28
2.4.4 Magnetometers & Magnetic Field Sensors	29
2.4.5 Fusion/Inertial Sensors (Inertial Measurement Unit - IMU)	33
2.4.6 Ultrasonic Sensors	34
2.5 Analytical Models Used to Analyze The Performance of Ultrasound Devices and Position Sensors	35
2.5.1 Analytical Models for Ultrasound Performance	35
<b>Chapter 3: Project Strategy</b>	<b>37</b>
3.1 Client Statement	37

3.2 Tolerance Angle Testing	37
3.3 Technical Design Requirements	38
3.3.1 Objectives	38
3.3.2 Design Constraints	40
3.3.3 Functions	41
3.3.4 Specifications	41
3.4 Design Requirements: Standards	42
3.5 Revised Client Statement	45
3.6 Management Approach	45
3.6.1 A Term	45
3.6.2 B Term	45
3.6.3 C Term	46
3.6.4 D Term	46
3.6.5 Deliverables	46
<b>Chapter 4: Design Process</b>	<b>48</b>
4.1 Need Analysis	48
4.2 Conceptual Designs	49
4.2.1 Ultrasonic Sensor	49
4.2.2 Magnetic Field Sensor	52
4.2.3 Inertial/Fusion Sensor (Magnetometer, Accelerometer, Gyroscope)	53
4.2.4 Inertial Measurement Unit (Attitude Heading Reference System Capability)	54
4.3 Design Alternatives	55
4.3.1 Ultrasonic Sensor with Accelerometer	55
4.3.2 Xsens IMU Sensor	56
4.4 Final Design Selection	57
<b>Chapter 5: Design Verification</b>	<b>59</b>
5.1 Data Analysis Overview	59
5.2 Accuracy of the Sensor's Gyroscope	59
5.3 Reproducibility Angle Testing with Sensor	61
<b>Chapter 6: Final Design and Verification</b>	<b>65</b>
6.1 Final Design Overview	65
6.1.1 Sensor Case: Version 1	65
6.1.2 Sensor Case: Version 2	67
6.1.3 Graphic User Interface	68
6.2 Final Design Impact	70
6.2.1 Economics	70

6.2.2 Environmental Impact	70
6.2.3 Societal Influence	71
6.2.4 Political Ramifications	71
6.2.5 Ethical Concerns	71
6.2.6 Health and Safety Issues	72
6.2.7 Manufacturability	73
6.2.8 Sustainability	74
<b>Chapter 7: Discussions</b>	<b>75</b>
7.1 Accuracy of the Sensor's Gyroscope	75
<b>Chapter 8: Conclusions and Recommendations</b>	<b>77</b>
8.1 Conclusions	77
8.2 Recommendations	77
<b>References</b>	<b>79</b>
<b>Appendix A: Residual Plots of the Raw and Roll Angles</b>	<b>86</b>
<b>Appendix B: Other Ultrasound Images from the Tolerance Angle Testing</b>	<b>87</b>
<b>Appendix C: MATLAB Code for GUI</b>	<b>88</b>

## List of Figures

Figure 2.1: Ultrasound Transducer with Embedded Sensor	22
Figure 2.2: Model of the Tactile Sensor	24
Figure 2.3: Layout of the tactile sensor array and the transducer	24
Figure 2.4: Model of the Sensor of a Laparoscopic Instrument	26
Figure 2.5: Positive angular velocity directions around the defined axes of an iPhone	28
Figure 2.6: Magnetic References for Positioning System	29
Figure 2.7: Magnetic indoor local positioning system using magnetic coil references	20
Figure 2.8: Representation of the Hall effect (B = magnetic field, I = current, V = Voltage)	31
Figure 2.9: Resulting magnetic flux at Hall sensor due to degree of rotation of a ring magnets having different number of poles	32
Figure 2.10: Dead-reckoning accelerometer and gyroscope measurements to produce position and orientation data	33
Figure 2.11: Pedestrian Dead Reckoning with inertial and magnetometer sensors	34
Figure 2.12: Use of Ultrasound Sensor to detect an object	35
Figure 2.13: Ultrasound-Guided Breast Biopsy Phantom	36
Figure 3.1: Ultrasound Images	38
Figure 3.2: Breakdown of deliverables	47
Figure 4.1: Layout of the Sensor connected to a Computer	50
Figure 4.2: Layout of the ultrasound sensors and the measurements being calculated	50
Figure 4.3: Resulting magnetic flux at hall sensor due to degree of rotation of a ring magnets having different number of poles	52
Figure 4.4: Pedestrian Dead Reckoning with inertial and magnetometer sensors	53
Figure 4.5: AHRS measurements	54
Figure 4.6: Model Prototype with Ultrasonic Sensor and Accelerometer	56
Figure 4.7: Xsens IMU Sensor	57
Figure 4.8: NGIMU Sensor	58
Figure 5.1: IMU Sensor Setup with Protractor	60
Figure 5.2: Accuracy of IMU Sensor in the Pitch Direction	60
Figure 5.3: Residual Plot in the Pitch Direction	61

Figure 5.4: Absolute Error With and Without the Help of the Sensor's Coordinates	
63	
Figure 5.5: Ultrasound Images	64
Figure 6.1: SolidWork Models of the Case and Lid	66
Figure 6.2: 3D Printed Case and Lid	66
Figure 6.3: Case with Medical Tape on Ultrasound Probe	68
Figure 6.4: GUI of Storing Euler Angles	69

## List of Tables

Table 3.1: Pairwise Comparison Chart	40
Table 5.1: Euler Angles with the Sensor	61
Table 5.2: Area of the Olive	63



## **Abstract**

Ultrasound (US) is a painless method of gaining a visual representation of the internal structures of a human body. It is used to look for diseases and other abnormalities. In effort to minimize and eliminate the amount of error generated by the operation of an US machine, a team of WPI students conducted research into the causes and reasons as to why these problems are not resolved. Ultimately, the team approached the problem through the use of an inertial measurement unit (IMU), and the development of a graphical user interface to track the orientation of an US probe. The results supported that feedback regarding probe orientation can increase the ability to reproduce ultrasound images.

## **Acknowledgements**

The authors would like to thank the following individuals for their help and guidance throughout this project:

Dr. Kwonmoo Lee, WPI Advisor and Biomedical Engineering Professor

Dr. Khashayar Rafatzand, Umass Memorial Hospital Advisor and Radiologist

Cindy Tefft, Umass Memorial Hospital Radiology Technician

Victor Andrade, Umass Memorial Hospital

Dr. Haihong Zhang, WPI Biomedical Engineering Professor

Dr. Yitzhak Mendelson, WPI Biomedical Engineering Professor

Lisa Wall, WPI Biomedical Engineering Lab Manager

## **Authorship**

All team members equally participated in the writing of this report.

## Chapter 1: Introduction

Ultrasound is a technology in which high frequency sound waves are transmitted to an object in the body by an electric pulse of a probe. Once the sound waves hit the object, the sound waves bounce off an object and are received by a probe in which the sound wave reflections are developed into an image [1]. In the past 30 years, usage of the ultrasound technology broadened into different fields including radiology, cardiology, and obstetrics-gynecology. The availability and usage of ultrasound devices has increased in developing countries and rural areas due to its affordability, user friendly design, durability, and portability. Hand held ultrasound devices increased popularity worldwide and helped find underlying illnesses in areas limited in resources [2] Accordingly, the presence of ultrasound devices is expected to grow at a compound growth rate (CAGR) of 8.1%, but the errors made in interpreting these images are still surprisingly significant [3] [4].

Although ultrasonography is revolutionary in medical diagnosis and has “changed clinical approach and therapeutic decisions in many fields of medicine,” it is strongly operator dependent. If an operator “skips over” an area of interest and no image is acquired and saved, important findings can be missed. In addition, based on the way an operator positions the ultrasound probe on a patient, the same object can look different. This can be problematic for radiologists when determining if the lesion of interest, for example, has grown from one scan to another. Despite structured training programs for ultrasound technicians and radiologists, operator-dependent errors remain an important clinical issue [5]. In fact, in follow-up ultrasound examinations, adjusting the probe position to “match” the current with prior images is one of the

most labor intensive and time consuming scanning tasks, especially in organs such as breast and thyroid and with irregular lesions. Even with a trained specialist in ultrasonography, diagnostic error is possible and it is the highest in cardiology and neonatology [6]. Technological advances such as 3D scanning and 3D probes have decreased the frequency of these errors, however, these technologies are expensive and not widely available especially in the developing countries. Interpretative errors in radiology today estimates between 15% and 20%, a statistic that has not changed since 1960 [3] [4]. Errors in ultrasound imaging is a result of image misinterpretation and miscommunication by the operator [3]. Although ultrasonography is revolutionary in medical diagnosis, there are not enough preventive measures to eliminate human error. Accurate systems that are designed to mitigate its frequency, visibility, and consequences could better measure the problem [5] [7].

In the past 30 years, usage of the ultrasound technology broadened into different fields including radiology, cardiology, and obstetric-gynecology. With limited establishment of standardized training and guidelines for diagnosis within and outside of professional's specializations, error related to subjective decisions made by ultrasound technicians and radiologists is significant [5].

To address the issue of inter-operator and inter-exam variability, the team has partnered with UMass Memorial Medical Hospital Radiology Department to design an 3D orientation sensor that can detect the orientation of the ultrasound probe regardless of the operator of the device.

It should be able to guide the user in whichever direction the user needs to move the probe in order to match the sonogram's orientation to that of of the last sonogram that was taken.

This will allow the next sonogram to be reproduced under the same probe orientation as the previous scan.

To complete our task of developing an orientation probe sensor, the team completed a series of objectives. First, the team addressed the reliability and reproducibility of the ultrasound images that will be taken using our device. As mentioned above, the device is intended to assist all users by providing orientation data of the 3D transducer. The team completed this objective by creating a way for the user to be able to monitor and see the orientation data in real time. To make the device universal, it will not be hardcoded into any specific ultrasound software but will instead stand alone.

The second objective is to design data storage for the device. This could be accessed from the patient's profile. This allows ultrasound technicians to access the necessary coordinates needed for the patient's ultrasound. The data storage capabilities were designed for easy implementation for ultrasound technicians to promote usability.

The third objective is to design a device that is easily usable. The device will simplify the training needed by new users. Furthermore, an easy to use system will indirectly decrease the amount of error created through the reliance on user judgement. The device's ease of use will come from multiple aspects of the device including but not limited to an easy to understand software or interface and an easy to handle form factor.

The fourth objective was to resolve our client's request for the device to be portable. With the possibility of our device being deployed in various environments including developing countries, it is important that our device be portable. To get the desired outcome, the team designed a stand alone system consisting of the team's add-on 3D device and a way that

displayed the real time coordinates for the user. Unlike its counterparts, the device will be easily packed away in the event that the user needs to become mobile. In addition, the team created a design that utilized an easy to use attachment for various existing probes.

Based on these objectives, the team designed and built a prototype that was tested to estimate the absolute error compared to the actual distance and angle measurements. The percent error needed to be under 4.4% or less to be considered accurate. The team made modifications when necessary. At the end of this project, the team had a functional concept and designed a orientation sensor device meet our objectives based on our initial client statement.

This product was developed in an organized and effective series of steps that is in line with the successive chapters of this research paper, will be followed. The next part of this paper is the Background Chapter. This chapter includes a literature review on ultrasounds and the applications of the orientation sensors. This will consist of details on current limitations, advancements, and methods available in these technologies. Discussions will also be outlining standards, benefits, and issues of sonography in both developed and developing countries. The Project Strategy Chapter details concept requirements and design development. The team discussed the logistics and primary outcomes that meets our sponsor's expectations and amended our initial project statement. Research on solutions and the current market on ultrasound orientation sensor technology. The team will then brainstorm ideas and create sketches for a design that best fits the description based on our technical and background research. In the execution of the Design Process, a final sketch of the system will be drafted. CAD models will be designed to build the prototype cases. The Design Verification process will be described including the raw results of the project (data, findings, and tests of designs). The Final Design

and Validation will be discussed, including summaries of our experimental methods, data analysis, explanations of how the team met the objectives, and the potential impact of our device on several aspects of society. The engineering, industry, and manufacturing standards will be implemented. In the discussion, a comparative analysis was conducted on current ultrasound technology. Limitations were also analyzed. Lastly, conclusions were stated along with descriptions and explanations for outstanding tasks and recommendations for future work concerning ultrasound orientation sensors.



## **Chapter 2: Literature Review**

### **2.1 Ultrasound**

#### **2.1.1 What is Ultrasound**

Ultrasound, also known as ultrasound scanning or sonography, is a painless and harmless technique used to construct a visual representation of a person's internal structures. As mentioned in the introduction, this technique uses high frequency sound waves which are transmitted to an object in the body using a probe that is placed on the patient's skin. To facilitate the device's ability to transmit and receive sound waves, an ultrasound gel is spread between the skin and the ultrasound transducer [1]. Ultrasound machines utilize a series of components that work in tandem to produce an image of the body's organs or structures including the transducer probe that was briefly discussed in the introduction, a transducer pulse control, a central processing unit, display, keyboard/cursor, disk storage device, and printer [12].

As one of the most crucial pieces to these machines, the transducer probe is responsible for creating sound waves, projecting them and receiving echos [12]. The transducer uses the piezoelectric effect, which allows electricity to flow based on the potential that is created when a crystal is distorted and compressed. The reverse can be said to happen if you flow electricity through the crystals instead [13]. To control the frequency and duration of the transducer pulses, the transducer pulse controls give the operator domination over the amount of current being passed through the crystals [12].

Much like a personal computer, ultrasound systems utilize a central processing unit (CPU) to combine the multiple types of inputs being generated by the transducer probe. As the brain, the CPU is responsible for doing all the calculations needed to produce an image of the region of interest. In 2D imaging, multiple flat cross section images are taken and converted into electrical signals by the CPU. This method is the most common standard in the industry.

However, ultrasound machines are able to produce more than just 2D images. They can produce 3D images, 4D images as well as Doppler Ultrasounds [12]. To create the more complexed 3D images, the CPU has to combine positional data, which is retrieved from position sensors and snapshots taken by the probe. Once processed, the combination of information is presented in a 3D image of the area of interest and is displayed for the user to see [12]. This type of ultrasound represents a more accurate picture of the area of interest. Similar to 3D ultrasounds, the 4D images utilize position to create a more comprehensive representation of the cross sectional area. In the fourth dimension, time is added, which creates the simulation of a moving picture. In this dimension, the CPU compiles multiple 3D images rapidly to create a moving image of the region of interest.

Lastly, doppler ultrasounds are also used in the industry. Unlike the 2D, 3D, and 4D ultrasounds, doppler is used in order to analyze blood flow rather than see structure. While it still uses high frequency waves, the doppler ultrasound instead looks for the returning signal that has bounced off the blood cells. Since the blood cells are in motion, the signal sent and the signal reflected will be slightly different. Using this data, the CPU can then calculate the direction of movement and the velocity at which blood is moving [12].

### **2.1.2 Importance of this field**

As mentioned in Section 2.1.1, ultrasound is used to create an image of internal body structures in human beings. Radiologists rely on diagnostic ultrasound scans to be able to diagnose patients and determine specialized treatment. This type of ultrasound is commonly used in pregnancy cases for routine checks and to keep track of fetus growth. Aside from pregnancy, diagnostic ultrasound can also be used to image organs such as the heart, blood vessels, brain, etc.

Outside of diagnosis, functional and therapeutic (or interventional) ultrasound are also used in different cases. With functional ultrasound, physicians are able to use it to assist in varying cases. In elastography, ultrasound is used to find the stiffness of tissue which can help physicians determine whether an abnormality may be a tumor or not. In other situations, physicians may use functional ultrasound to help them perform more precise operations such as biopsies. In therapeutic ultrasound, the sound waves are used in targeting specific areas in the body in order to heat or break up damaged tissue.

## **2.2 Main Causes/Issues of Ultrasound Reproducibility**

### **2.2.1 The use of ultrasounds without position sensors**

Good quality ultrasound systems are relatively expensive and are not easily available across all demographics. Prices could be up to thousands of dollars for position sensors, and oftentimes you would need to buy in bulk. Position sensors in the medical field are not usually used with user interfaces in mind. They are usually used for special applications. Along with

other tracking systems in an ultrasound device, it is difficult for all socioeconomic groups to have access to these devices [13].

### **2.2.2 Current Methods of Improving User Accuracy**

There are different preventative measures that can be put in place to decrease human error and optimize accuracy in the field of ultrasonography. 3D Ultrasound devices give enhanced diagnostic capabilities to make it easier for less trained professionals to interpret different ultrasound images compared to a 2D ultrasound system device. The key to converting 2D images to 3D images, however, is sensing the orientation of the transducer relative to the ultrasound image being constructed [14]. This could also be obtained by a compilation of different 2D array scanners to build a 3D volumetric image. Different positioning systems can be used such as magnetic or optical trackers [15]. However, these features are only exclusive to non-portable ultrasound devices. Optical fibers and sensors however, can be implemented into a portable ultrasound system without losing accuracy [15]. This is done by having an attachment placed on a transducer handle which can help with user accuracy. For example, a mouse driver was used to extract position information from the sensor, recording the acceleration of the mouse driver. This was tested to have a high accuracy of 55mm movement [15]. Different analytical methods are used by ultrasound technicians to identify the proper orientation of lesions. There are how lesions interact with their surrounding environment that could produce. This includes linear lines and slight reflections, as told to us by an ultrasound technician.

### **2.2.3 Common errors in sonography**

The increase of human errors in radiology have been on the rise and is a “well known problem within the radiological community...demonstrating the importance of diagnostic

quality for patients and payers” [16]. Approximately one billion radiologic image exams are performed worldwide, having the lowest estimate of radiological error of four percent [16]. Error is contingent if the operator views images less than four seconds, it does not consult prior reports, it experiences image acquisition error and interpretive error [16]. However, errors are not exclusive to radiologists, but extends to neonatologists. Due to the the lack of standardization, the levels of training needed to ensure accurate use of the ultrasound device in medicine has not been defined, including developing countries [16]. In a study internal medicine, residents received training for one hour using a hand held ultrasound device. After a week of training, sixteen out of sixteen residents performed better than average in their evaluation of 20 carotid arteries with minimal or no plaque [17].

However, in another clinical study, diagnostic error were measured by individuals that were not pediatric cardiologists and non-pediatric cardiologists [18]. One group consisted of external patients who received echocardiograms between 1996-1999 while internal patients received initial echocardiographic diagnosis that were expected to go under corrective surgery [18]. The results showed that 44 percent of patients in the external group received diagnostic errors while the internal study group had three percent of incidence of wrong diagnosis [18].

This included different examinations such as cardiac, vascular, and abdominal scans. Forty three percent of all patient cases agreed that use of an ultrasound scanner changed their initial management plan. Although there has been overall positive influence of using this portable version of the ultrasound, there remains a lack of ultrasound trained physicians and sonography education [19].

#### **2.2.4 Effect of Orientation on Ultrasound Image Measurements**

Good alignment between the plane of the transducer on the body and the underlying region of interest (ROI) can be reached through different combinations of probe rotation and tilt [11]. This shows that it is not wrong to take an ultrasound images at slightly different angles because you can get good images in a variety of ways depending on the area of the body. The problem is that there are tolerance limits where offsetting the angle/orientation of the transducer/probe too much starts causing distortion of the image on the ultrasound. This is very critical when comparing sonogram images as a lesion in one image may have measurement errors caused by transducer angle, but may be misinterpreted as the actual size of the lesion.

Although the research is limited, there are specific tolerance ranges that have been devised for certain muscle groups in the body. A study done on muscle fascicle length and pennation of the medial gastrocnemius muscle, making up part of the calf, used a virtual 2D ultrasound simulator to compare the 3D muscle structures taken at different orientations. It was mentioned that measurements are usually the most accurate when the image plane is in line with the muscle fascicles, but that this position can be hard to reach so there tends to be some error in the alignment. The results of this experiment showed that on average, the error in the measurement of fascicle lengths was about 0.4 millimeters per degree of misalignment, but when the probe/transducer was tilted 20 degrees, the error rises 1.1 millimeter per degree. Good alignment was defined as less than 1 degree of misalignment for which the average absolute error was only less than 1.5 millimeters for every tilt angle. The smallest absolute error occurred when the probe was held perpendicularly to the leg surface. For pennation the errors were more

outstanding if the transducer was not parallel to the skin. A 20 degree tilt could cause the error to be greater than 5 degrees although fascicle misalignment was only 1 degree [11].

Another study investigated the information required in ultrasonography to avoid significant error in muscle measurements. The sonograms were taken based on common criteria used to choose the orientation of the probe, but this orientation deviated from the actual plane of the fascicle by 15 degrees. This shows the importance of being able to compare two images from the same orientation, despite common criteria or standards employed in taking ultrasound images on a specific area of the body. The 15 degree deviation led to fascicle length errors up to 14% and fascicle angle errors up to 23% [20].

Another study on transducer orientation showed its effects on abdominal muscle thickness & bladder position. It was mentioned that motion can distort ultrasound images and can lead to inaccurate conclusions. The ultrasound images were taken at the lateral side of the abdominal wall and at the base of the bladder. Digital motion capture recorded the amount of degrees that the transducer/probe was oriented along 3 rotation axis for testing. It ranged from about -10 degrees to 10 degrees along each axis. The results showed that there was not a significant change in the thickness of the transversal abdominal if the rotation of the transducer was below 10 degrees or if the “cranial/caudal or medial/lateral” tilt was less than 5 degrees. There also were no critical changes in the position of the base of the bladder when the rotation (clockwise/counter-clockwise) was less than 10 degrees or when the tilt was less than 10 degrees or when inward and outward movement was less than 8 millimeters [21].

## 2.3 Current Technology and Their Limitations

### 2.3.1 Embedded Sensor in Ultrasound Probe

The current gold standard of an ultrasound imaging sensor is an ultrasound probe with an embedded sensor, which was patented back in April 2003. A model of the transducer can be seen in Figure 2.1. The transducer probe (2) consists of the position sensor (3) and the array (32) of discrete elements that transmit ultrasound waves and receive ultrasound waves reflecting from the subject area [22]. In this embodiment, the array (32) of piezoelectric crystals is connected via array signal wires (33) with a transducer probe cable (44) [22]. The position sensor (3) is made up of a unit (23) for optically acquiring images of a surface of the subject area during operation, for acquiring information from said images, and for processing said information from the acquired images into positional information on the transducer probe (2) relative to the subject area [22]. The sensor (23) is connected via position signal wires (45) to the transducer probe cable (44) [22].

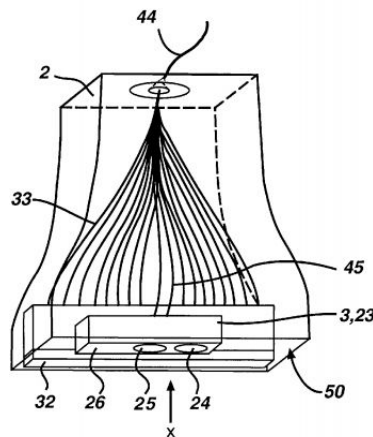

Figure 2.1: Ultrasound Transducer with Embedded Sensor [22]



The problems with this device is that the sensor is embedded inside the transducer. However, the team's position sensor is going to be attachable to the surface of the transducer probe. In addition, the sensor does not indicate whether the transducer is at the correct position, in which our group plans on resolving.

### **2.3.2 Tactile Sensor**

Another kind of ultrasound imaging sensor is a tactile sensor. The sensor, which is made using polydimethylsiloxane (PDMS), is mounted on the surface of an ultrasound transducer as shown in Figure 2.2, and the sensor measures the contact pressure between the transducer and the tissue being analyzed. As the pressure increases, there is an increase change in the dielectric properties, meaning that the capacitance increases as well. The PDMS material covers an electrode pattern made of titanium (Ti) and gold (Au) [23]. The Ti and Au covers a shielding part of a non-adhesive polyimide (PI) film. The sensor is connected to polymethylpentene (PMP, which is also known as TPX) which is a substrate using silicone adhesive on the back surface of the adhesive PI film [23]. Polymethylpentene has a high acoustic transparency and is commonly used in ultrasound devices [23]. Being able to understand the contact pressure between the probe and the tissue is beneficial for learning ultrasound imaging techniques and performing repeatable screening and diagnostic tasks [23]. The work done in this study has been used for breast cancer diagnosis, but the process has been used for other screening and diagnostic ultrasound tasks [23]. Figure 2.3 shows an ultrasound transducer with a tactile sensor. The bottom piece is the tactile sensor while the top piece is the transducer, which consists of an acrylic indenter and a silicon tip, for better surface contact with the sensor.

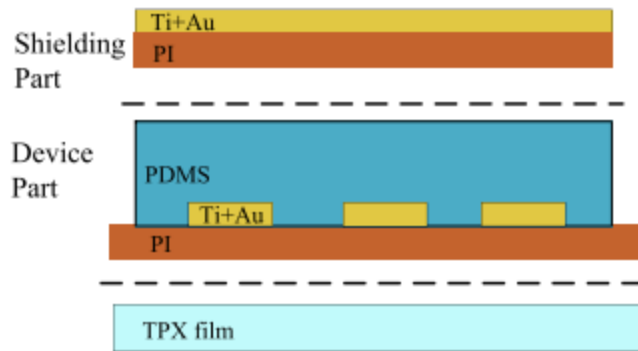

Figure 2.2: Model of the Tactile Sensor [23]

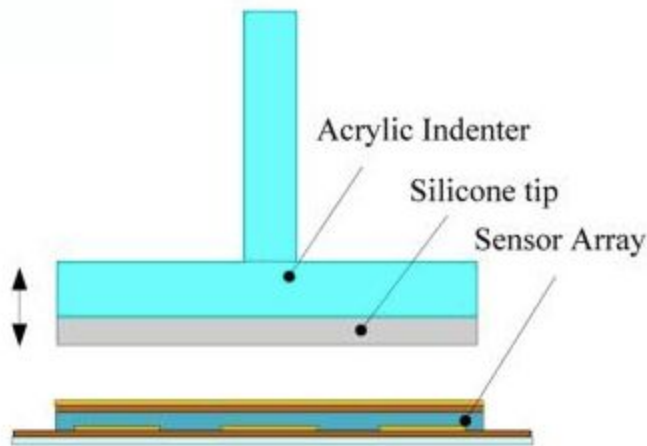

Figure 2.3: Layout of the tactile sensor array and the transducer [23]

A tactile sensor is used for ultrasound transmissivity, is good in a clinical and biomedical research in ultrasound image formation and interpretation, however there are limitations. This includes ultrasound transmissivity being high if the sensor is used commercially in a product [23]. Also, the sensor discrepancy of acoustic impedances between the integrated device

(pressure sensor and ultrasound probe) and the tissue [23]. Finally, a tactile sensor does not detect the position of where the sensor is located on the body compared to a reference point.

### **2.3.3 Ultrasonic Sensor in Laparoscopic Instruments**

Ultrasonic sensors are also used in laparoscopic surgery in which they can be used to measure position and orientation as shown in Figure 2.4. The sensor consists of 4 groups of 4 receivers in 2 by 2 meter dimension that is used to 3-dimensionally locate the transmitter positions [24]. By using the echo pulse method as shown in Eq. 2.1, the distance (D) between the transmitter can be calculated using the velocity of sound (V) and the time of flight (TOF) of an object traveling through a median to a targeted object. In this study, it is the time the sound waves have traveled from the transmitter to the receiver.

$$D = \text{TOF} * V \quad (2.1)$$

From that, the 3D position can be determined [24]. For orientation, a pair of transmitters is used to measure this quantity of the instrument. If the measurement between transmitter and one corner is blocked, the information could be extracted from the data collected at the other corners [24].

One major problem with this device is that the temperature of the device can affect the distance measurement and will only work at a temperature of 23° C, the standard temperature in a surgical room [24]. In addition, our sensor needs to be used in ultrasound imaging. As

mentioned, the ultrasound probe is embedded with a sensor, but the sensor does not indicate whether the transducer is placed in the correct position.

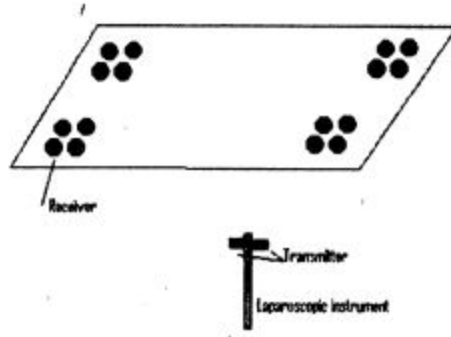

Figure 2.4: Model of the Sensor of a Laparoscopic Instrument [24]

## 2.4 Position Sensors

### 2.4.1 Optical Sensors

Optical sensors record the position of an object using a phototransistor or an image sensor. A phototransistor causes the current to change based on the amount of light that it is receiving. The image sensor requires markers to be placed on the device or object to be tracked, and the sensor records the movement of the markers [25]. The optical sensor method works if there is nothing blocking the path between the sensor and the markers/device.

### 2.4.2 Accelerometers

An accelerometer measures changes in velocity. It is a measurement of all of the forces that are acting on the sensor. These forces could be static, like the force of gravity ( $9.8 \frac{m}{s^2}$ ), which does not change or they could be dynamic which causes the sensor/an object to move or vibrate. If the accelerometer is stationary on a table, it will measure acceleration as  $9.8 \frac{m}{s^2}$  due to

the table applying an upward force onto the accelerometer, keeping it up against gravity. This gravity measurement can be extracted so it does not show up in measurements. Acceleration without the gravity vector is known as linear acceleration. Linear acceleration is useful for recording steps and shakes without producing noise caused by the gravity measurements.

Accelerometers are usually used in fusion sensors (in combination with other sensors) to acquire more useful information [26]. Isolated gravity is the measurement of only the acceleration due to gravity (static). Isolated gravity reveals the tilt of an object with respect to the strongest local magnetic field, which would be earth if there is no other magnetic material around [27]. A low pass filter will help isolate gravity and measure tilt, however, the filter introduce a delay [26]. This method of sensing the absolute orientation is not the most accurate [27].

In order to get the position information from acceleration measurements, a double integral of acceleration needs to be taken as seen in Eq. 2.2 and Eq. 2.3:

$$\text{Velocity: } v = \int_{t_0}^{t_1} a dt \quad (2.2)$$

$$\text{Position: } x = \int_{t_0}^{t_1} v dt \quad (2.3)$$

Taking the two consecutive integrals above causes the signal to drift as seen in Eq. 2.4 and Eq. 2.5:

$$\text{Acceleration: } a = g \sin(\theta) \quad (2.4)$$

$$\text{Position: } x = \frac{1}{2} a t^2 \quad (2.5)$$

Therefore, position measurements without any alterations made to remove drift, are not accurate [26].

### 2.4.3 Gyroscopes

A gyroscope measures angular velocity ( $\frac{\text{radians}}{\text{sec}}$ ) relative to itself. This is the rate at which the device rotates around a certain axis in the device's specified coordinate system. In other words, the gyroscope measures its own rotation [26]. It uses the Coriolis effect, which is a force that acts perpendicularly to a rotating body's axis of rotation [28]. The direction of rotation is defined by the right hand rule in a device's coordinate system where the positive direction of rotation is viewed as clockwise from the positive side of an axis [26]. An example of this can be seen for the device (iphone) in Figure 2.5 below:

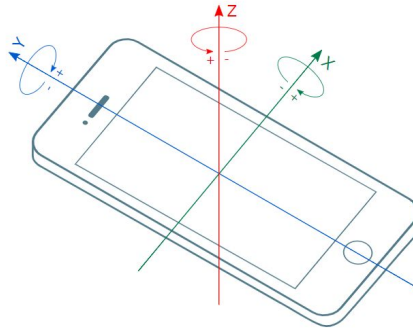

Figure 2.5: Positive angular velocity directions around the defined axes of an iPhone [29]

There is one integration that is required to get the angle of rotation (a measure of distance using angle) from the angular velocity values that a gyroscope produces, as seen in Eq. 2.6:

$$\int_{t_0}^{t_1} \cos(2\pi ft), \quad f = \frac{\omega}{\pi}, \quad \omega = \text{angular velocity} \quad (2.6)$$

A limitation of gyroscope measurements is that the measurements drift over time. This is caused by the integration in Equation 2.6 which turns noise into drift. Therefore, it is important to take measurements quickly and account for any error in the time difference [26]. Another potential limitation is that gyroscopes oscillate at high frequencies which makes it very sensitive

to all movement. This could be a problem if a device containing the gyroscope has small vibrations due to the motor inside of it. Also, gyroscopes use a lot of power because of the high frequency oscillations.

#### 2.4.4 Magnetometers & Magnetic Field Sensors

Magnetometers measure the orientation of components in the strongest magnetic field, producing a 3D magnetic field. If the magnetic field nearby is not strong enough, it will sense the earth's field. If there is another magnetic object in the vicinity of the magnetometer, the resulting measurements will be relative to this undesired magnetic field [26]. The positioning and presence of a strong magnetic field, besides that of earth's, can be intentional and useful, depending on the application, for the purpose of choosing your own reference point(s) as seen in Figures 2.6 and 2.7.

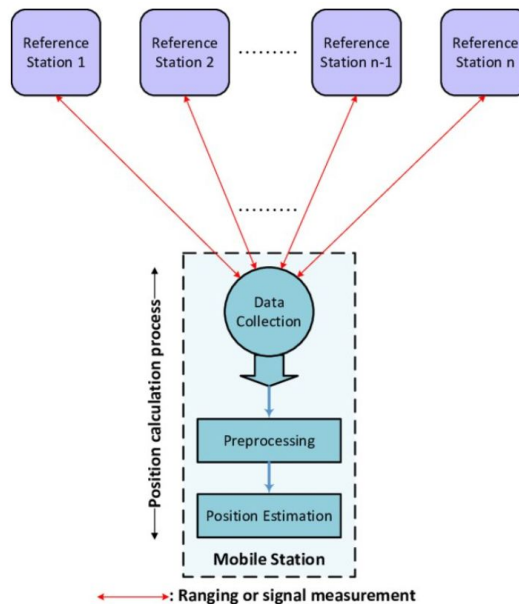

Figure 2.6: Magnetic References for Positioning System [30]

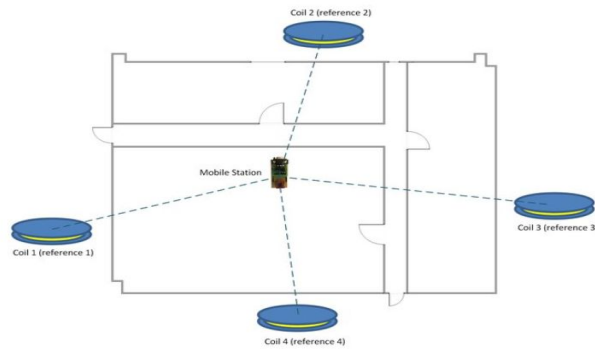

Figure 2.7: Magnetic indoor local positioning system using magnetic coil references [31]

The most common way magnetometers are used are in a fusion sensor, which combines multiple sensors. A gravity vector is necessary to be able to tell how the device is held (tilt compensation). For the gravity vector, an accelerometer is used. If nothing is moving around that is magnetized in the room, it should be stable enough to isolate gravity. A gyroscope could be added as well to increase the precision of the measurements [26]. Fusion sensors are further discussed in Section 2.4.5.

Some examples of different types of magnetic sensors include Hall-Effect sensors and Weigand sensors. Hall-effect sensors/devices require the use of an external magnetic field. The output of this sensor is a voltage that changes based on the response to the magnetic field [32]. When a current carrying conductor is put into a magnetic field, there is a voltage that results parallel to the current and the magnetic field, which is the Hall effect shown in Figure 2.8.



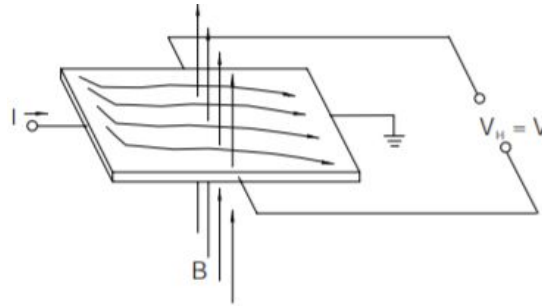

Figure 2.8: Representation of the Hall effect ( $B$  = magnetic field,  $I$  = current,  $V$  = Voltage)

There are different configurations for a hall sensor. The hall sensor can be unipolar head on or slide by referring to the way that the magnet moves relative to the sensor. It can also be bipolar slide-by which uses two magnets connected to each other and the distance is measured relative to the middle of the magnet duo. These bipolar sensors could be used to measure linear movement or rotation. The bipolar slide-by using a ring magnet can measure rotation. The ring magnet is circular with two or more magnetic pole pairs around it. Figure 2.9 shows the resulting magnetic flux at the sensor compared to the the degrees of rotation. The degrees of rotation is characteristic of the number of poles that a specific ring magnet has [33].

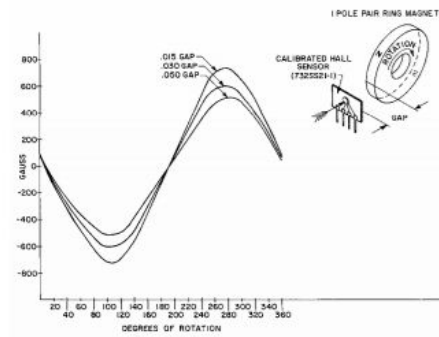

Figure C-27 Ceramic .75" dia. (3/8" mounting hole) ring magnet. Recommended for linear applications

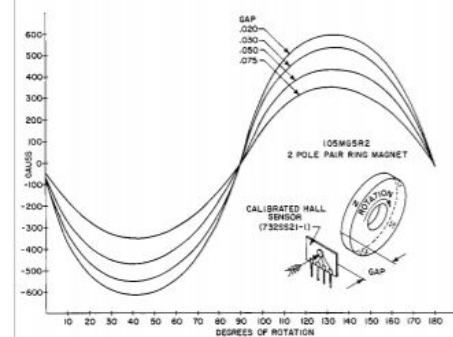

Figure C-28 Indux .625" dia. x .20" thick ring magnet

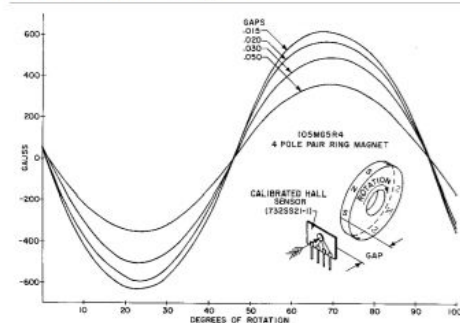

Figure C-29 Indux .625" dia. x .20" thick ring magnet

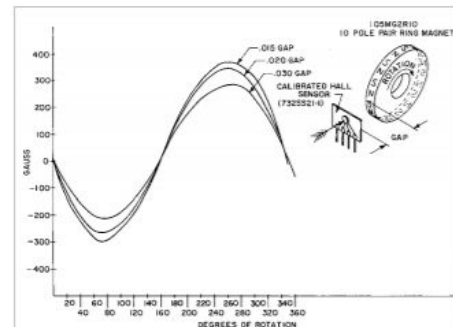

Figure C-30 Lodex 42 1.75" dia. x .14" thick ring magnet

Figure 2.9: Resulting magnetic flux at Hall sensor due to degree of rotation of a ring magnets having different number of poles [33]

The advantage of using magnetic field over certain other sensors, like optical, is that it is unaffected by unmagnetized objects that move in front of or around the object being measured. For example, there are sensors that give accurate positional information when used for a short time period but cause a drift in position and time results when used for longer time periods. Some of these sources produce absolute position measurements but rely on other conditions or infrastructure. This is why magnetometers are used in most inertial measurement units [34]. There has also been successful self-localization trials using wireless, attachable magnetometers [35].

### 2.4.5 Fusion/Inertial Sensors (Inertial Measurement Unit - IMU)

Fusion sensors combines data from different types of sensors. These tend to be more accurate or useful in many applications than the use of position sensors individually.

One combination of position sensors is the accelerometer and gyroscope. This is also known as an inertial sensor. Devices, which measure position/orientation using these sensors, are called inertial measurement units (IMUs). Figure 2.10 shows how dead-reckoning these measurements can be used to provide useful position and angle data:

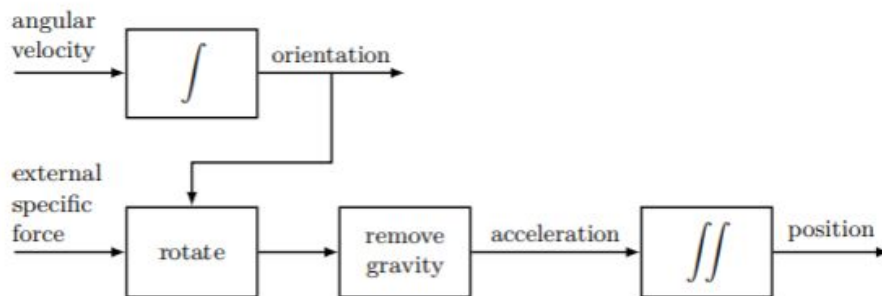

Figure 2.10: Dead-reckoning accelerometer and gyroscope measurements to produce position and orientation data [36]

As mentioned previously, both of these sensors are subject to drift over long periods of time during use. They are more accurate on shorter time scales. These measurements can be improved by compensating for the delays or using additional sensors.

Another combination of position sensors, which was mentioned in Section 2.4.4, is the accelerometer, magnetometer and sometimes the gyroscope as well. Inertial measurement units can also include magnetometers which can be a huge benefit depending on the application. An

example of using this three-sensor unit to extract position and orientation data for tracking pedestrian navigation is shown in Figure 2.11:

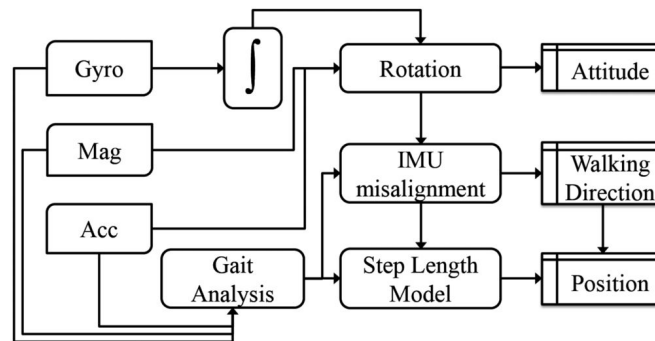

Figure 2.11: Pedestrian Dead Reckoning with inertial and magnetometer sensors [37]

#### 2.4.6 Ultrasonic Sensors

The purpose of an ultrasonic position sensor, which is shown in Figure 2.12, is to detect different regions or targets with the use of sound wave, while it measures its position and distance [38]. This uses time to calculate the distance of the object from the sensor [39]. Without an ultrasonic position sensor in the ultrasound system, the user is not able to locate or identify the distance of the region of interest and the common transmitter (sound waves) can not be emitted. A use of a reference point is advised. Ultrasound position sensors can also be used outside of an ultrasound to sense distance of other objects.

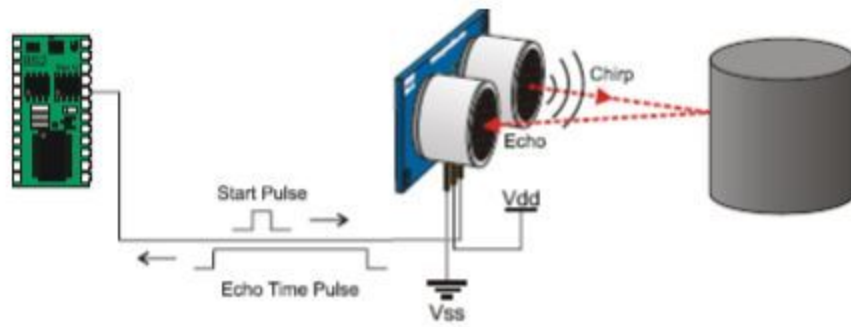

Figure 2.12: Use of Ultrasound Sensor to detect an object [39]

## 2.5 Analytical Models Used to Analyze The Performance of Ultrasound Devices and Position Sensors

### 2.5.1 Analytical Models for Ultrasound Performance

Phantoms are one of the most important analytical models used to test how well an ultrasound works. A medical imaging phantom is a material/object that is designed to mimic body tissue for the purpose of evaluating the performance of a medical imaging device [15].

These phantoms give ultrasound technicians the capability to compare the performance of different ultrasound systems to decide which works better, without having to use human subjects. They can be used to compare current ultrasounds to computer models when trying to develop a new product. There are many types of phantoms that are designed to mimic different tissue types and organ systems, including soft tissue and hard tissue [19]. Phantoms can have multiple applications as you can see in Figure 2.13, where the breast phantom is being used for training in ultrasound guided biopsy.



Figure 2.13: Ultrasound-Guided Breast Biopsy Phantom [18]

It is common practice to use raw chicken breast to train ultrasound technicians to detect phantoms, which represents lesions found in the human body. The chicken breast has the same consistency of soft tissue of the body that is made up from water. This makes it a good contrast with the human anatomy. This technique is also used at UMass and was explained to the team by an ultrasound technician. By puncturing the chicken breast with your finger, then filling the cavity with ultrasound gel. The pimiento stuffed olive is then inserted and could be observed by the ultrasound probe at various angles. It is necessary to place ultrasound gel between the probe and the chicken breast as you would do to a human breast for good wave conductivity.

## Chapter 3: Project Strategy

### 3.1 Client Statement

At the beginning of the project, the team was given the following client statement that was formulated from the initial project proposal:

“Design an **add-on** 3D position sensor that can be **easily operable**, track and record the probe’s position and orientation, communicate with the system that records the ultrasound, and provide **feedback** to the ultrasound operator.”

### 3.2 Tolerance Angle Testing

During one of the conversations with our advisor Dr. Rafatzand, from UMass Memorial Center, one area in ultrasound he told the team how the angle is crucial due to slightest changes could affect the image that is produced. The team went to UMass Memorial where the team took ultrasound images of an olive inside the chicken breast at various angles to determine how much change in the angle causes change to the ultrasound image. To test angle tilt to the left of the chicken breast, the team started at 0° (vertical position). The pictures for the first chicken breast were captured at an angle of 0°, 4.4°, 13°, 17.6°, 30.8° and 36.1°. Beyond 36.1°, the tumors are no longer visible through the ultrasound machine. To test angle tilt to the right of the smooth chicken breast, the team started at 0° (vertical position) once again and measured at angles of 0°, 13.6°, 25.9°, 36.4°, 43°, and 50°. After 43°, the tumors were had mostly disappeared from view. Based on the images collected, the team determined that at 4.4°, there was noticeable change in the image compared to the image at 0°, which meant that the

device needs to be within  $4.4^\circ$  when taking an ultrasound of the same area of interest at a later time. The images at  $0^\circ$  and  $4.4^\circ$  are shown in Figure 3.1 and where the image changes (red arrow).

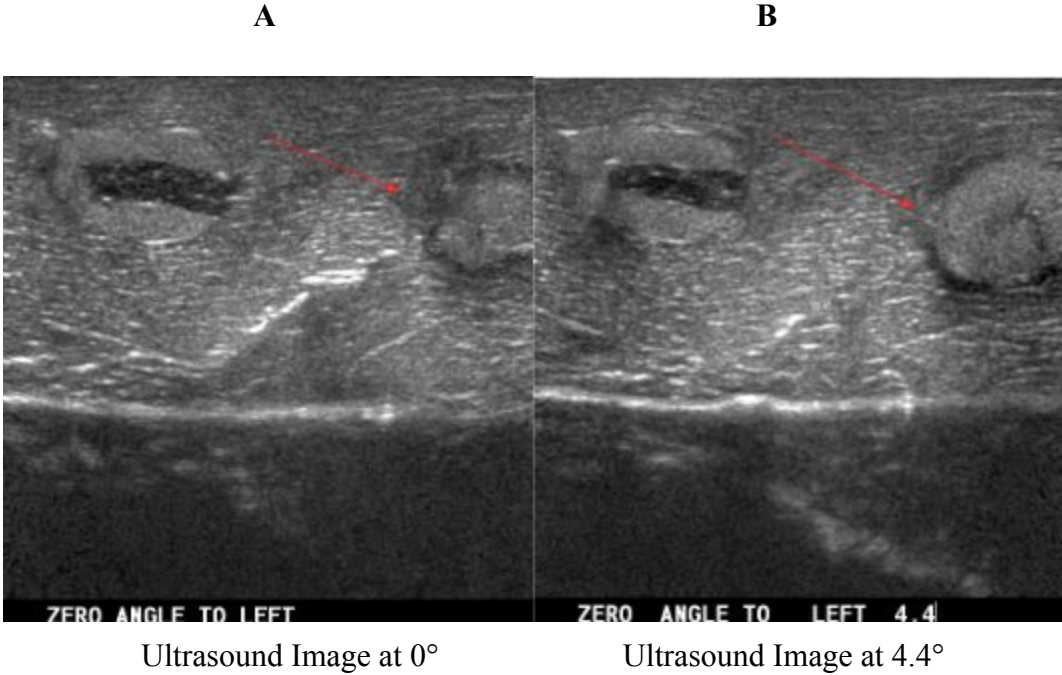

Figure 3.1: Ultrasound Images A) at  $0^\circ$  and B)  $4.4^\circ$ .



## 3.3 Technical Design Requirements

### 3.3.1 Objectives

After the team revised the client statement after consulting and meeting with Dr. Rafatzand, the team's objective was to design a sensor that uses orientation of the body to allow definite conclusions based on the ultrasound images. The final device aimed for radiologists to be able to better compare images based on the images' orientations. This will make the ultrasound procedure easier and faster for the ultrasound technicians. From this, our team created the following objectives:

1. **Data Storage:** The coordinates and the angle of the sensor needs to be saved in some software that can be used for future use of the same patient.
2. **Portability:** Our device must be able to be moved around in the event the device does not stay in one location.
3. **Attachability:** The device has to connect to an ultrasound probe promotes ease of use for ultrasound technicians to control.
4. **User Friendly:** Reduction in training curve for ultrasound usage by technicians, promoting quicker procedures.
5. **Reproducibility:** Image orientation of in the body must be easily replicated using the same coordinates in a second procedure. The orientation of the images can allow radiologists to make conclusive conclusions about any changes that occurred in the body. In addition, it can also limit the number of follow up appointments that the patient needs to schedule.

6. Monitor Position: The device must be able to detect the position of the ultrasound probe based on a reference.
7. Monitor Orientation: The device must be able to detect angle of the ultrasound probe.

After coming up with our seven objectives, the team designed a pairwise comparison chart as seen in Table 3.1. A zero meant that the top objective is more important than the left objective, whereas a one meant that the left objective is more important than the top objective. The three most important considerations that the team is considering based on the total score are monitoring orientation, reproducibility, and data storage.

Table 3.1: Pairwise Comparison Chart

Design Objectives	Data Storage	Portable	Attachable	User Friendly	Reproducible	Monitor Position	Monitor Orientation	Total
Data Storage		1	1	1	0	1	0	4
Portable	0		1	0	0	0	0	1
Attachable	0	0		0	0	0	0	0
User Friendly	0	1	1		0	0	0	2
Reproducible	1	1	1	1		1	0	5
Monitor Position	0	1	1	1	0		0	3
Monitor Orientation	1	1	1	1	1	1		6

### 3.3.2 Design Constraints

Before the team developed a portable 3D orientation sensor, it was necessary to evaluate different constraints for the potential design. Although subject to change, these are the constraints that needed to be considered before developing the sensor. This includes the time needed to develop the device and the size of the sensor. The size of the sensor should be able to

mount on any hand held ultrasound device. Requirements include a functioning 3D orientation sensor that provides feedback to the user with data storage capabilities. The development of these tasks were completed under a eight month time frame. In these eight months, the team iterated through multiple designs and ran tests that needed to be kept within the team's budget.

### **3.3.3 Functions**

A list of functions were developed based on the objectives. The device must require minimal training from ultrasound technicians, promoting ease of use. The device must allow for ultrasound technicians to place the device on the area of the body that is going to be used during an ultrasound. When the probe is placed on the area of interest where the ultrasound image is taken and the sensor's coordinates get stored into a software, requiring minimal input from the technicians. A push of a button from the ultrasound technician should record the probe orientation information for any patient. The software should also require minimal training to minimize the required input from the technicians and should handle any errors to make the procedure go as fast as possible. When a patient comes in for an ultrasound with the same orientation as before, ultrasound technicians could move the 3D orientation sensor and attach the sensor to the probe to receive continuous feedback. This will determine when the transducer is placed correctly on the body. Once the second ultrasound is done, the radiologists can more accurately explain to the patient what they analyzed by using images that were taken in similar positions.

### **3.3.4 Specifications**

Compatibility of the orientation sensor might pose an issue due to various handheld ultrasound devices available on the market. The 3D sensor should also be compatible to different

models of handheld ultrasound device systems and give accurate feedback to the users on an understandable interface. A reference point might also need to be established, depending on the type of ultrasound exam conducted that would provide the user with reliable data points. A test program is to be developed to test the sensor accuracy. The team kept these specifications in mind for our users to utilize these functions with ease. The sensor should be on top of the ultrasound probe without interaction with the user and the overall weight should be light enough to not cause discomfort from the user. This specific weight can be tested and feedback could be provided by the ultrasound technicians themselves. Lastly, computer software is needed to translate the movement of the sensor into logged data, then onto a user friendly computer interface that any ultrasound technician could interpret.

### **3.4 Design Requirements: Standards**

There are engineering standards that describe characteristics and technical details that should be taken into consideration and employed in the design of the team's ultrasound orientation sensor. These standards provide specifications, guidelines, and requirements that should be used consistently to guarantee that products are suitable, safe, and function well for their given purpose [40]. These standards are accepted by different authorities as the most practical and fitting solutions available for a repeating/widespread issue [41].

The American College of Radiology (ACR) has Standards related to ultrasonography. The first one that applies to our project is ACR-SPR-SRU "Practice Parameter for Performing and Interpreting Diagnostic Ultrasound Examinations Res. 32 – 2017." This document includes standards for ultrasound examinations in many different fields of imaging including breast,

thorax, obstetrics, and many more. These will be used in our project to craft the design of the positioning device based on the standard positions that the ultrasound technicians hold the ultrasound [42]. Since the focus of our design is for breast imaging freehand ultrasounds, the team will most likely focus our design on rotational positioning and angle since it is standard to conduct breast imaging with the ultrasound placed horizontally [43]. If the ultrasound is not placed horizontally, this could result in large errors in interpreting the size of a tumor in the breast. There are also standardized ways of reporting information [42]. This is mostly directed to the physician; however, since our device will be recording positioning and orientation information and revealing this data to the user, the team needs to take into account how information is recorded for permanent record.

The CAD standards will be taken into account as the team models our designs for the ultrasound probe position sensor. The team will be focusing on the Mechanical CAD standards. Technical product documentation information is given in ISO 13567 and ISO 16792 which include data set identification and control, design model requirements, special notations, geometric tolerances, surface texture, and more [44]. Technical drawing standards are given in ISO 128 [45]. More geometric standards are given in ISO 1101 [46]. Solidworks drafting software has a capability of ensuring that the CAD drawings comply with ISO standards for specifications on dimensions.

Our final designs will be crafted within these requirements before being finalized. The following are standards from the Institute of Electrical and Electronics Engineers (IEEE) that relate to computer and electronic equipment. IEEE 1554-2005 is recommended practices for inertial sensor test equipment, instrumentation, data acquisition, and analysis [49]. This

information can be used in our method of extracting orientation data from a sensor. There is another set of standards of performance parameter definitions that can be utilized to test the functionality and implementation of an accelerometer, magnetometer, gyroscope, or proximity sensors combined [50].

Digital Imaging and Communications in Medicine (DICOM) standards might need to be used in relation to our devices communication with devices displaying medical images [51]. According to the scope of DICOM standards, “The DICOM Standard pertains to the field of Medical Informatics. Within that field, it addresses the exchange of digital information between medical imaging equipment and other systems [52].” Moreover, it mentions diagnostic medical imaging in fields like radiology but could be applied to imaging and non-imaging related information in other clinical/medical environments. These standards will be taken into account in regards to the standard communication methods used in medical imaging.

If our final design has an operating function that connects with another medical communication system wirelessly, it will need to meet Federal Communication Commission (FCC) standards, which regulate power levels and frequencies to ensure that there is no interference with similar devices. Risk assessments can be conducted on the device to ensure the safety of the device on the ultrasound, the operator (ultrasound technician), and the patient at which the ultrasound is done. Health information privacy will be taken into account due to the device’s ability to record a patient’s orientation data. These Health Information Privacy laws and regulations, includes the Health Insurance Portability and Accountability Act (HIPAA), which will craft how probe orientation data is stored and what is needed in order to keep the information confidential [53].

### 3.5 Revised Client Statement

After considering the requirements and objectives of the project, the team revised the client statement:

“Design an **add-on 3D orientation** sensor that **easily** measures, records, and stores the angle measurements and provides **feedback** on whether the accuracy of the current angle measurements are met.”

### 3.6 Management Approach

The development of our device concept will require multiple objectives to be achieved as stepping stones to our final design. Some major milestones are the submission and completion of all chapters, the production of a design(s) and building our prototype(s).

#### 3.6.1 A Term

- BME 4300 Presentations 1 to 4
- Completed Chapters 1 through 4

#### 3.6.2 B Term

- Researching different types of Sensor
- Choosing and Finalizing Sensor

### **3.6.3 C Term**

- Design and 3D Print Case for Sensor
- Research and implement signal processing for Sensor

### **3.6.4 D Term**

- Performed Accuracy and Reproducibility Testing with Sensor
- Developed Graphical User Interface (GUI)
- Completed Final Presentation
- Completed and Revised Final Report

### **3.6.5 Deliverables**

Our three main deliverables for this project, as illustrated by Figure 3.2, was researched in the form of this document (a research paper), a design of our prototype and test results. In this document, background findings, our design approach, restraints, requirements, and team management will be presented. For a design, the team intends to create multiple prototype designs before evaluating them. The team will then decide which prototype will best fits our purpose while sacrificing minimal functionality properties. The team's decision on a final design will then be reinforced through prototype testing.



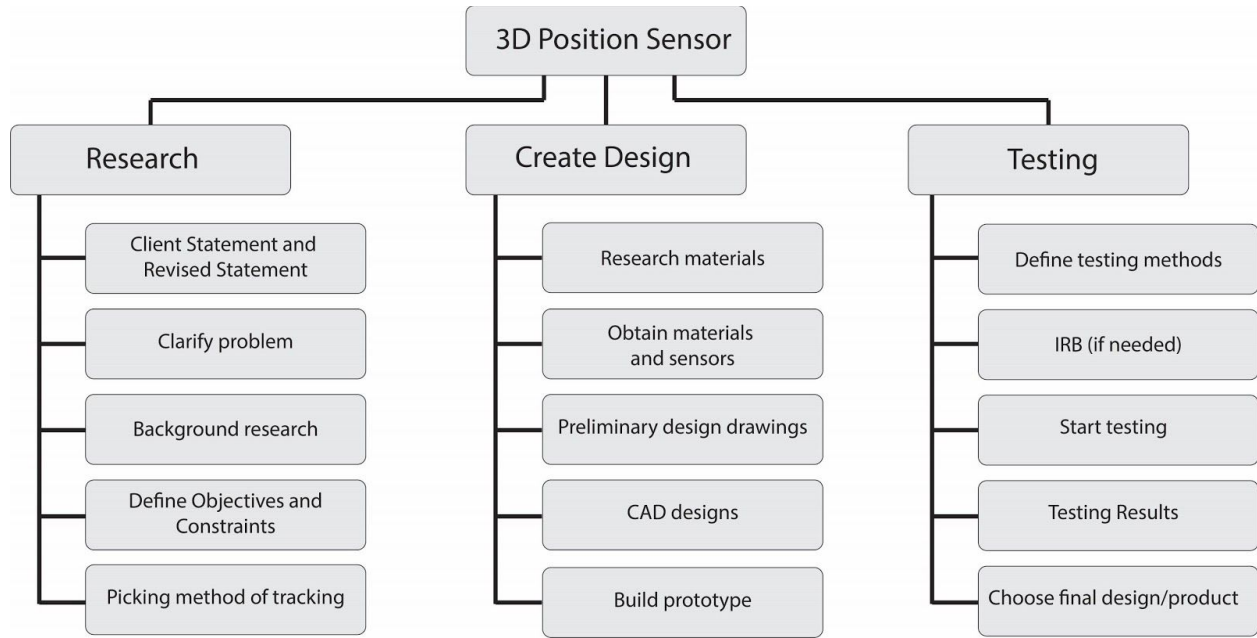

Figure 3.2: Breakdown of deliverables

## **Chapter 4: Design Process**

### **4.1 Need Analysis**

The needs of the users/recipients of the results of the position sensor device will determine what the final requirements are. User's wants will be taken as secondary needs. In the context of the design, the final requirements should be narrowed down based on the top priorities and needs of the main stakeholders.

Based on the Table 1 in Chapter 3.3.1, the most important need is monitoring orientation of the ultrasound probe. According to our advisor, Dr. Rafatzand, orientation/rotational sensing is a necessity while position should be incorporated if there is time and resources. Orientation sensing is the main feature that the user will receive from our device. The next most important requirement would be reproducibility of the ultrasound image. This is what will allow our device to be a lot different from other sensors. Ultrasound users will be able to compare their current orientation to the desired orientation to get a more accurate image. The third most important requirement is data storage which allowed the team's device to use the orientation information in a user friendly way. Data storage allowed the probe's orientation coordinates from a patient's last visit to be compared to the current orientation of the probe, thus producing reproducible results.

The operator will be provided an orientation sensor that is user friendly, portable, and attachable. Different users of the sensor include ultrasound technicians or any qualified person who could operate an ultrasound system. It is important to consider comfortability and ease of use while prototyping and designing our device. Ultrasound sonographers must repeat the same procedure in order to adjust to the add-on sensor. This means that the location of the orientation

sensor on the ultrasound probe should not interact where the ultrasound technicians hold the probe. For additional comfort, the orientation sensor on the ultrasound should be significantly lighter than what an ultrasound weighs. This will be more comfortable for the ultrasound user and for the patient. In addition, the size of the sensor has to be small enough for technicians to move the ultrasound probe freely.

## **4.2 Conceptual Designs**

Based on prior research on ultrasound and position and orientation sensors, conceptual designs were considered to monitor and record the exact coordinates of the human body during an ultrasound. All of these concepts are designed to meet our need analysis in section 4.1.

### **4.2.1 Ultrasonic Sensor**

One concept that the team is considering is using the ultrasonic sensor to detect the position and orientation. The sensor is connected to a computer via an interface board as seen in Figure 4.1 [54]. A USB port is used to transfer all the data from the interface to the computer. All the data collection is done on Visual Studio 2008 software with VC++ programming language [54].

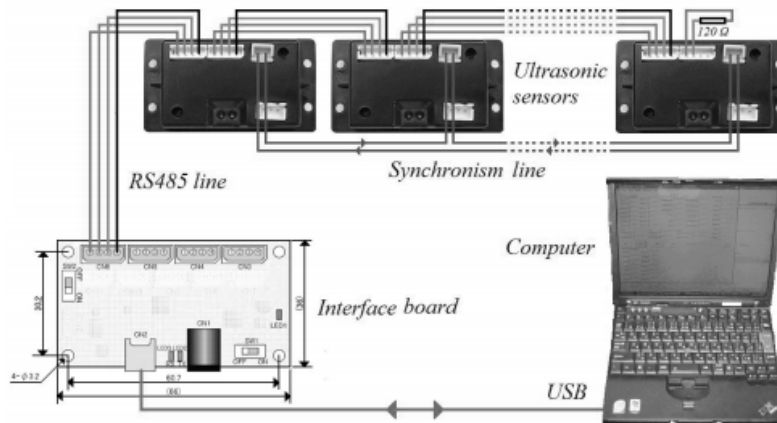

Figure 4.1: Layout of the Sensor connected to a Computer [54]

Two references for the ultrasonic sensor is a laser range finder, which is used to measure distance and a fiber optic gyroscope, which is used to as an angle reference sensor for evaluating orientation [54]. In Figure 4.2, it shows how the sensors are lined up and what measurements are being calculated.

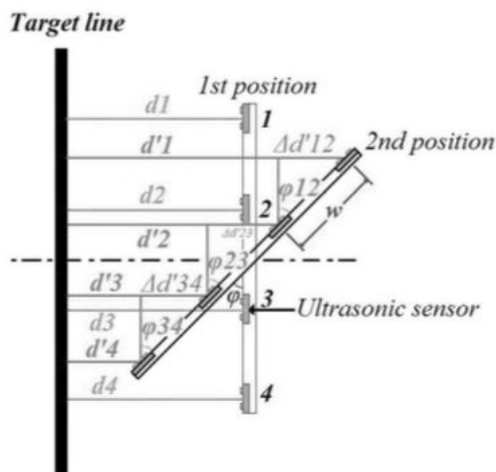

Figure 4.2: Layout of the ultrasound sensors and the measurements being calculated [54]

The following equation is used to calculate orientation [54]:

$$\varphi_{lk}(t) = \sin^{-1}(d_{lj}(t)-d_{li}(t))/w \quad (4.1)$$

$$\varphi_l(t) = (\sum \varphi_{lk}(t))/num \quad (4.2)$$

$$\varphi_{rk}(t) = \sin^{-1}(d_{rj}(t)-d_{ri}(t))/w \quad (4.3)$$

$$\varphi_r(t) = (\sum \varphi_{rk}(t))/num \quad (4.4)$$

$$\varphi(t) = (\varphi_l(t)+\varphi_r(t))/2 \quad (4.5)$$

where  $i = 1, 2, 3$ ,  $j = 2, 3, 4$ , and  $k = 1, 2, 3, 4, 5, 6$

$\varphi_{lk}(t)$ : orientation from  $i, j$  sensors in the left side in time  $t$  (deg)

$\varphi_l(t)$ : orientation average of the left-side sensors in time  $t$  (deg)

$\varphi_{rk}(t)$ :  $i, j$  sensor orientation in the right side in time  $t$  (deg)

$\varphi_r(t)$ : orientation average of the right-side sensors in time  $t$  (deg)

$\varphi(t)$ : final orientation in time  $t$  (deg)

$d_{li}(t)$  and  $d_{lj}(t)$ : output of sensor  $i$  or  $j$  in the left side in time  $t$  (cm)

$d_{ri}(t)$  and  $d_{rj}(t)$ : output of sensor  $i$  or  $j$  in the right side in time  $t$  (cm)

$w$ : distance between two sensors in one side (= 22 cm)

$num$ : number of USS3's (ultrasonic sensor) in each side (= 4)

The following equation is used to calculate position [54]:

$$e_{li}(t) = d_{lj}(t)-((w_p-w_u)/2) \quad (4.6)$$

$$e_l(t) = (\sum e_{li}(t))/num \quad (4.7)$$

$$e_{ri}(t) = ((w_p-w_u)/2)-d_{ri}(t) \quad (4.8)$$

$$e_r(t) = (\sum e_{ri}(t))/num \quad (4.9)$$

$$e(t) = (e_l(t)+e_r(t))/2 \quad (4.10)$$

where  $i = 1, 2, 3, 4$

$e_{li}(t)$ : position from sensor  $i$  in the left side in time  $t$  (cm)

$e_l(t)$ : average of positions of the left-side sensors in time  $t$  (cm)

$e_{ri}(t)$ : position from sensor  $i$  in the right side in time  $t$  (cm)

$e_r(t)$ : average of positions of the right-side sensors in time  $t$  (cm)

$e(t)$ : final position in time  $t$  (cm)

$w_p$ : width of path (= 115 cm)

$w_u$ : distance between USS3 sensors in left and right sides (= 44 cm)

## 4.2.2 Magnetic Field Sensor

Another concept that the team considered was the use of a magnetic field sensor. This position sensor required an external magnetic field, so it is not simply an “add-on” position sensor to an ultrasound probe. There are two options which included the Hall-effect sensor and the Wiegand sensor. The Hall effect sensor can measure rotation using a bipolar sensor measuring rotational movement. A ring magnet is positioned around the ultrasound probe and the Hall Sensor in a specific, stationary location that measures the magnetic flux. The ring magnet has two or more sets of poles which allow the hall sensor to measure rotation based on the changes in polarity as it rotates [55]. Figure 4.3 shows the different Hall effect sensor results (magnetic flux vs the degrees of rotation) based on the number of poles that the ring magnet has.

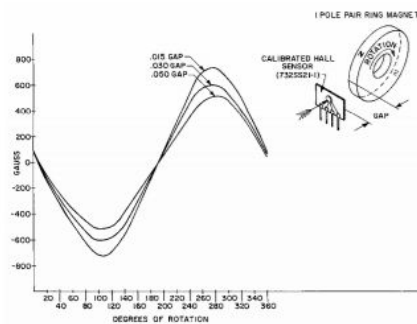

Figure C-27 Ceramic .75" dia. (3/8" mounting hole) ring magnet. Recommended for linear applications

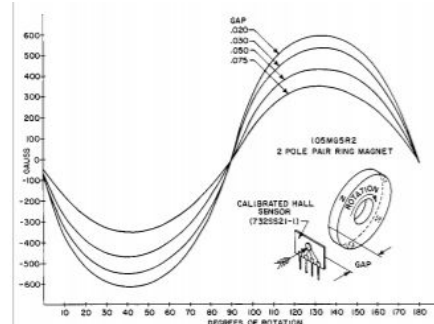

Figure C-28 Incox .625" dia. x .20" thick ring magnet

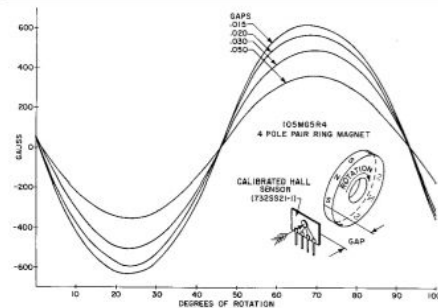

Figure C-29 Incox .625" dia. x .20" thick ring magnet

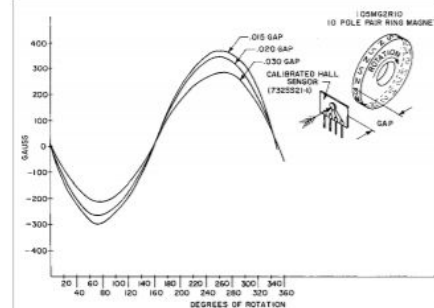

Figure C-30 Lodex 42 1.75" dia. x .14" thick ring magnet

Figure 4.3: Resulting magnetic flux at hall sensor due to degree of rotation of a ring magnets having different number of poles [55]

### 4.2.3 Inertial/Fusion Sensor (Magnetometer, Accelerometer, Gyroscope)

The other concept that our team considered was a fusion sensor, which combined multiple inertial sensors. This included a magnetometer, accelerometer, and gyroscope. The team can choose to neglect one of the sensors within this fusion sensor in final design. This device does not have a reference point relative to the patient and is based around gravity. In order to use a fusion sensor, an ultrasound technician will have to take note of the position that the patient was in when taking the ultrasound. The patient then must be put back in the same position before attempting to reproduce the position of the probe on the patient the next time the ultrasound is taken [23]. Figure 4.4 represents how this fusion sensor can be used to return orientation, position, and direction in an example application of pedestrian navigation.

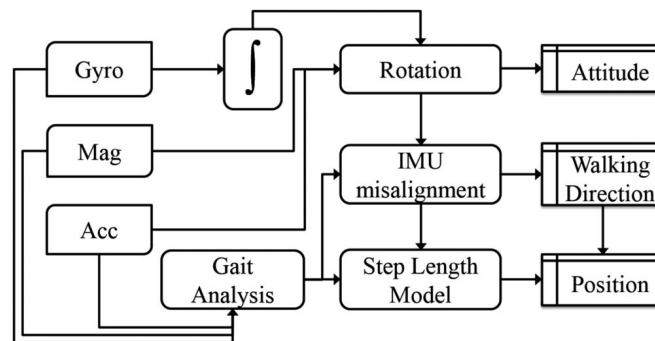

Figure 4.4: Pedestrian Dead Reckoning with inertial and magnetometer sensors [23]

MEMS inertial measurement units (IMUs) are lightweight and reasonably priced sensors that can incorporate the inertial sensors described above.

#### 4.2.4 Inertial Measurement Unit (Attitude Heading Reference System Capability)

The final design that our team considered was an inertial measurement unit that has attitude heading reference system (AHRS) capability. This is commonly known for being used in airplanes. It consists of sensors on three axes that provide attitude information including roll, pitch, and yaw which coincide with x, y, and z axes as shown in Figure 4.5. This sensor could be positioned on the ultrasound probe and the roll, pitch, and yaw euler angles could be displayed for an ultrasound technician to view. This information could also be programmed so that an LED would change color depending on a threshold of how close the ultrasound technician is to the last saved attitude angles [56].

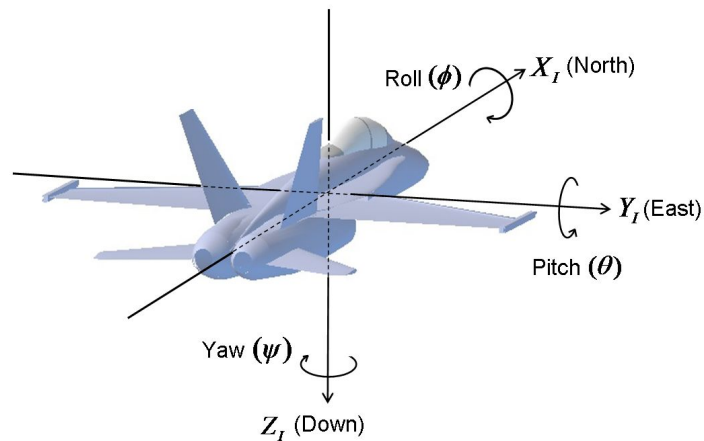

Figure 4.5: AHRS measurements [56]



## **4.3 Design Alternatives**

### **4.3.1 Ultrasonic Sensor with Accelerometer**

The ultrasonic sensor and the ADXL335 accelerometer were attached to an arduino board. As both sensors change positions and orientations, that data is sent to the arduino. The coding for the arduino is then processed, and finally, the LCD shows position (distance) and orientation (tilt) of both sensors. Although the sensors would have a low amount of energy to operate, the set up as seen below is too large to lie on the transducer, which would result of the model prototype to fall and possibly damage the circuit set up. In addition, it would very difficult for the technicians to fix the model prototype if the set up malfunctions since they do not have the necessary background in circuitry and programming [57].

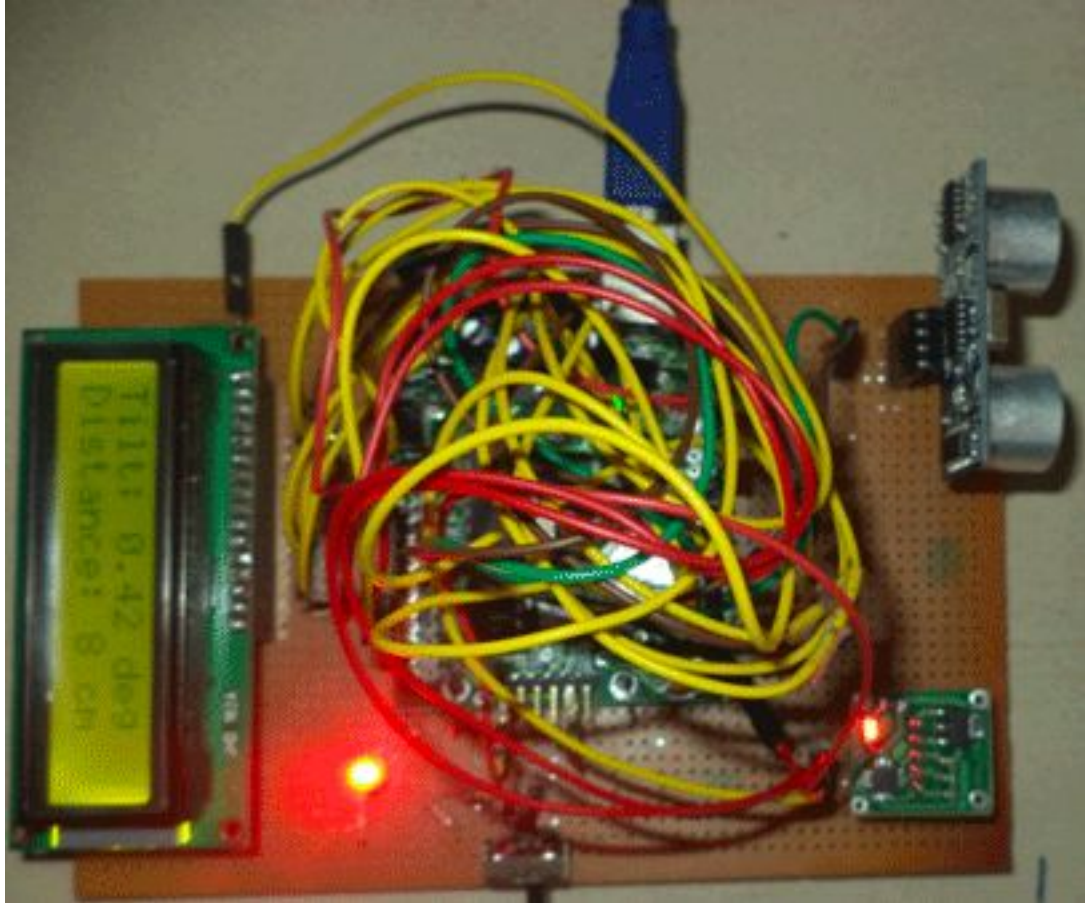

Figure 4.6: Model Prototype with Ultrasonic Sensor and Accelerometer [57]

### 4.3.2 Xsens IMU Sensor

The sensor has the built in accelerometer and gyroscope necessary to determine position and orientation. This sensor has a built in software that needs to be set up in order to process the data and signals. As the sensor moves, the software shows the exact position and orientation along the x-, y-, z- axes. In addition, the sensor is very small, so it can attach to the ultrasound probe without falling. The affordability of the sensor was a problem for the team to purchase, for it was about \$450. The sensor also was developed in the Netherlands, which concerned the team about shipping time and cost [58].

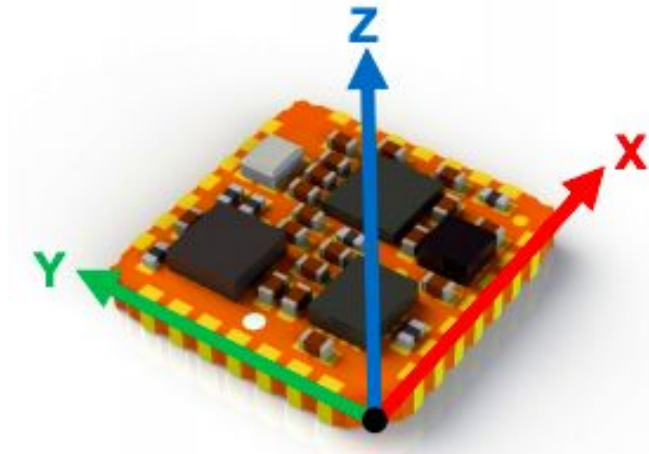

Figure 4.7: Xsens IMU Sensor [58]

#### 4.4 Final Design Selection

After the team compared the sensors that were out on the market, the team decided to use a Next Generation Internal Measurement Unit (NGIMU) sensor as shown in Figure 4.8 because of the useful features such as an accelerometer, magnetometer, gyroscope, and an AHRS system. The AHRS system would provide an easy way for an ultrasound technician to quickly view the three angles and adjust the orientation of their probe to meet the indicated values. Despite the sensor costing about \$300 and having a shipping time of one week, it was chosen due to its Wi-Fi capability and real-time communication that comes built into the IMU. It is important that this device was not a big distraction or intrusion in the space of the ultrasound technician. This made wireless capability is extremely important. The sensor was attached to a battery for power and connected to a computer using Wi-Fi with optional hard wire connection.

The team took two measurements which was recorded to analyze the orientation, linear acceleration, and attitude using euler angles. Both the accelerometer and the gyroscope had a

sampling frequency of 400 Hz, which provided data points every 2.5 ms. The sensor also came with its own graphical user interface , which made it helpful for testing. A new graphical user interface was developed using MATLAB. This interface allowed the ultrasound technician to view the attitude of the sensor in real time. Ultrasound technicians were able to save the data at where an image is taken and when they want to return to that position. It will be able to press a button which displayed the previously saved attitude data. While viewing their current orientation in real time, the ultrasound technicians was able to compare and save the current roll, pitch, and yaw angles and adjust her orientation to meet them as they see fit.

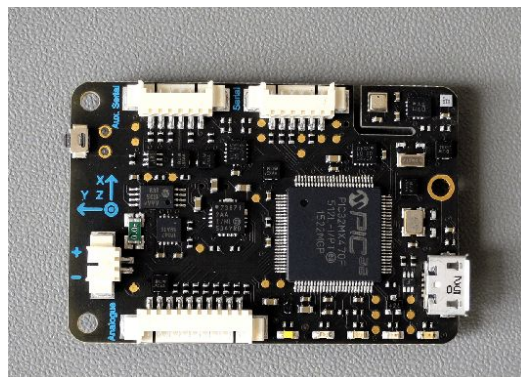

Figure 4.8: NGIMU Sensor [59]

## **Chapter 5: Design Verification**

### **5.1 Data Analysis Overview**

The team advanced and proved our proof of concept by designing some tests to provide and an idea and give the team an understanding of the kind of data that the team should come to expect. For all of the testing done at Umass Memorial Hospital, the ultrasound machine that was used was a Philips IU22. The depth was 8 cm with a variable frequency between 5 Hz - 12 Hz. The probe was SN-81727. The images taken on the ultrasound machine different settings affected the image seen such as the brightness, contrast, absorbance levels, greyness, gain, light, spatial depth. These settings were up to the operator's preference that could alter the displayed image.

### **5.2 Accuracy of the Sensor's Gyroscope**

An electric protractor was used to determine the accuracy of the sensor's euler angles, which included roll, pitch, and yaw, measured through the sensor's Altitude Heading Reference System. The electric protractor was moved every one degree from 0 to 10 degrees, every 5 degrees from 10 to 20 degrees, and every 10 degrees from 20 to 130 degrees. The IMU sensor was placed in the slot of the protractor as shown in Figure 5.1. When the change of pitch angle was measured, the sensor was oriented in the protractor in the pitch direction so that as the angle of the protractor was increased or decreased. The pitch angle would then be most affected and would vary respectively. At each degree measured, the angle provided by the sensor was

measured. The graph in Figure 5.2 shows the relationship between the protractor and angle measurements in the pitch direction as well as the calculated  $R^2$  value. Figure 5.3 shows the residual plot in the pitch direction. The residual plots for the accuracy tests done on the yaw and roll angle measurements can be found in Appendix A.

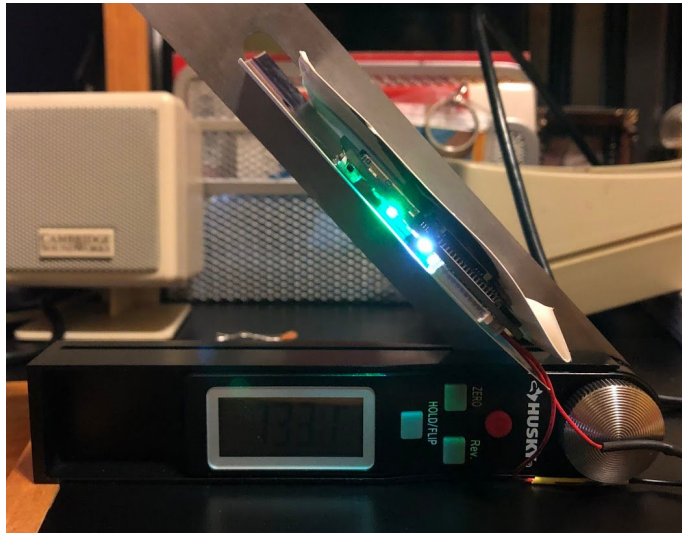

Figure 5.1: IMU Sensor Setup with Protractor

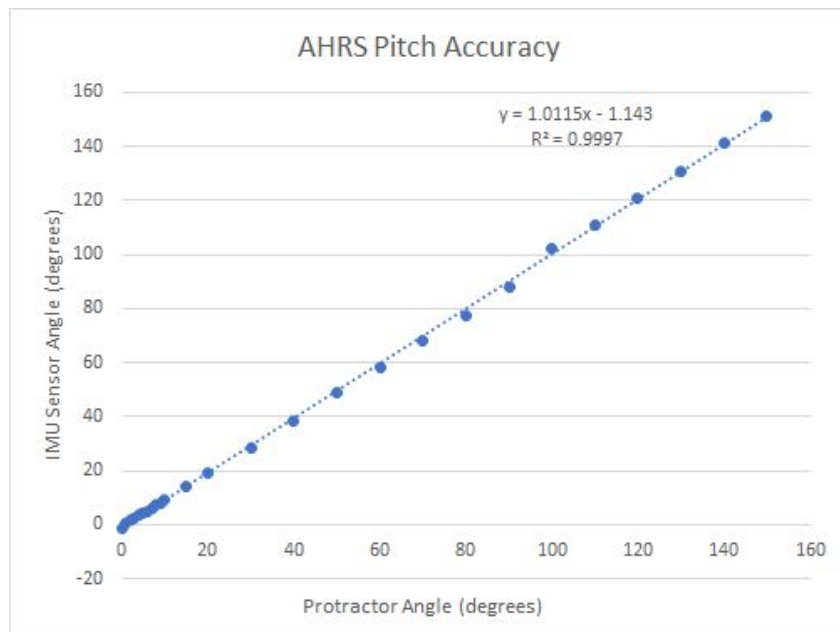

Figure 5.2: Accuracy of IMU Sensor in the Pitch Direction

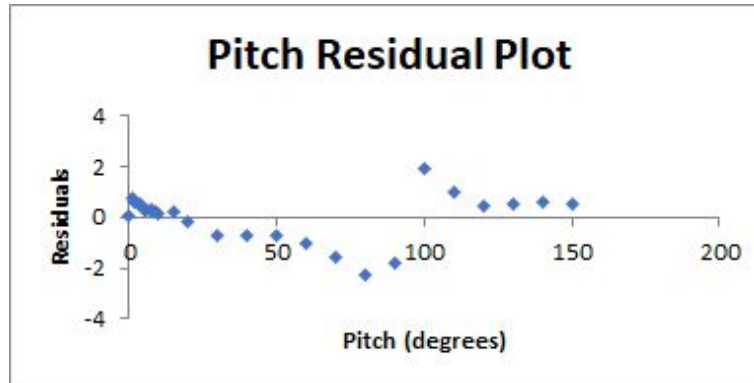

Figure 5.3: Residual Plot in the Pitch Direction

### 5.3 Reproducibility Angle Testing with Sensor

To validate the tolerance angle of  $4.4^\circ$  in Section 3.2, the team had the ultrasound technician reproduce the same image of the olive inside the chicken breast with the sensor attached to the probe. This test was conducted on three different chicken breasts as seen in Table 5.1. The team first had the ultrasound technician take an ultrasound image of the olive, and the team recorded the roll, pitch, and yaw coordinates, which was denoted as the control. Then, the ultrasound image took two additional ultrasounds of the same olive using two different methods. The first method was reproducing the control ultrasound image without the help of the sensor's coordinates, which was denoted in the table as *Without Sensor's Help*. After completion of the first method, the technician was ask to reproduce the control ultrasound image with the help of the sensor's coordinates, which was denoted in the table as *With Sensor's Help*. In each case, the coordinates were recorded after the technician felt that the image shown was the same as the control image. After the coordinates were determined after three trials, the absolute error was later calculated. This was completed by subtracting the roll, pitch, and yaw coordinates from the

control ultrasound image from the ultrasound image's roll, pitch, and yaw coordinates with and without the sensor's coordinates and taking the absolute value of the difference.

In addition, the team recorded the amount of time it took for the technician to produce the images with and without the sensor's coordinates.

Table 5.1: Euler Angles with the Sensor

Chicken 1					
	Control	Without Sensor's Help	With Sensor's Help	Absolute Error (°)	
Euler Angle	Located	Re-located	Re-located	Without Sensor	With Sensor
Roll (°)	-76.3	-72	-76.1	4.3	0.2
Pitch (°)	-2.4	-2.4	-2.6	0	0.2
Yaw (°)	149.7	147	149.6	2.7	0.1
Time Taken (s)	N/A	35	17		
Chicken 2					
	Control	Without Sensor's Help	With Sensor's Help	Absolute Error (°)	
Euler Angle	Located	Re-located	Re-located	Without Sensor	With Sensor
Roll (°)	-75.7	-70	-76.4	5.7	0.7
Pitch (°)	-11.8	-9.9	-11.6	1.9	0.2
Yaw (°)	136.2	141.2	136.2	5	0
Time Taken (s)	N/A	17	123		
Chicken 3					
	Control	Without Sensor's Help	With Sensor's Help	Absolute Error (°)	
Euler Angle	Located	Re-located	Re-located	Without Sensor	With Sensor
Roll (°)	-81.5	-71.4	-81.1	10.1	0.4
Pitch (°)	-11	-5	-11	6	0
Yaw (°)	123.5	123	123	0.5	0.5
Time Taken (s)	N/A	113	37		

The mean absolute error with and without the sensor's coordinates during each chicken breast trial is shown in bar graph in Figure 5.4. The dark blue graphs represents the sensor's coordinates without help while the light blue graphs represents the sensor's coordinates with help.



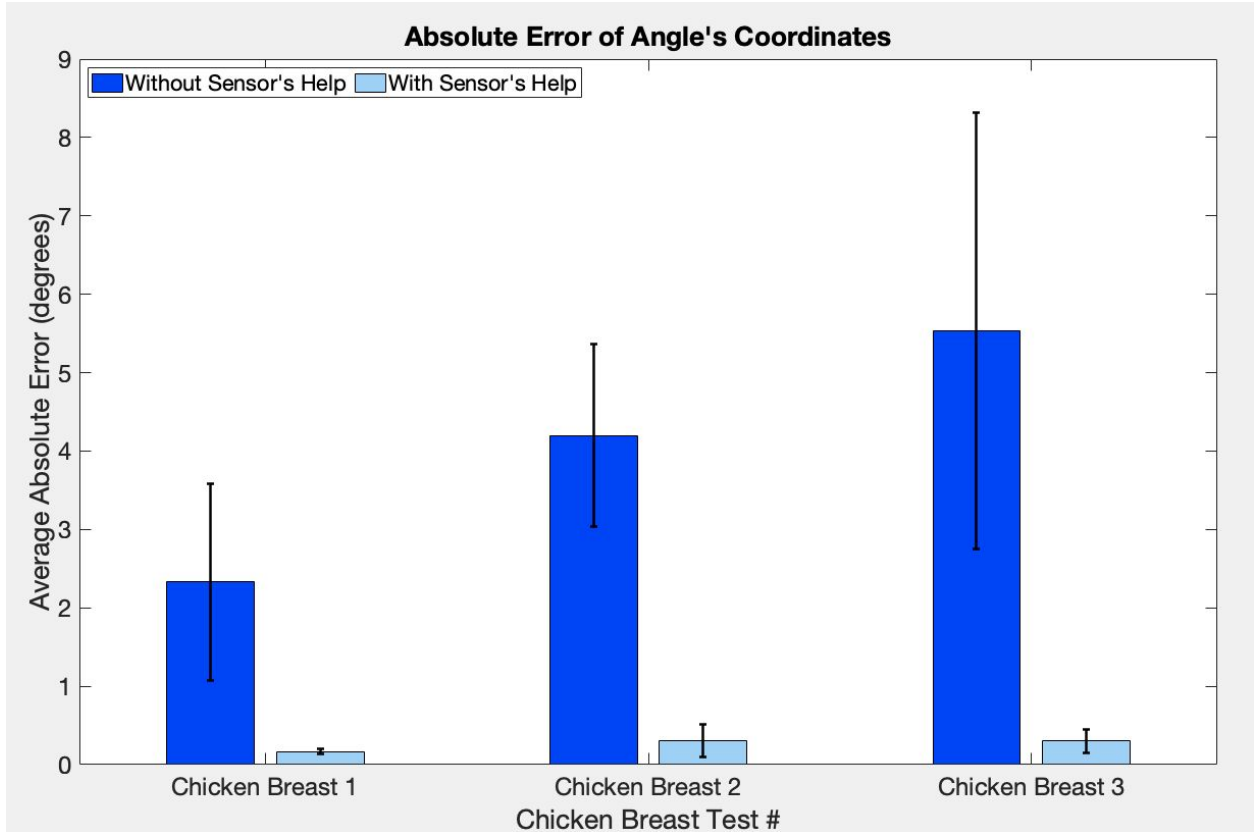

Figure 5.4.: Absolute Error With and Without the Help of the Sensor's Coordinates

The team observed any changes to the size of the olive, and the initial area of the olive was calculated. Assuming the shape of the olive in the ultrasound image was an ellipse, the area of the olive was calculated using the following formula:

$$\text{Area} = A * B * \pi \quad (5.1)$$

where A is the length of the semi-major axis and B is the length of the semi-minor axis.

The area of the olives during the chicken breast testing is shown in Table 5.2.

Table 5.2: Area of the Olive

Area (cm <sup>2</sup> ) of the Olive in the Ultrasound Image			
	Control	Without sensor	With sensor
Chicken 1	3.29	5.89	6.35
Chicken 2	2.85	5.48	6.05
Chicken 3	3.34	4.42	5.59

The ultrasound images with the olive (red arrow) inside the chicken breast are shown in Figure 5.5. The rest of the images can be found in Appendix B.

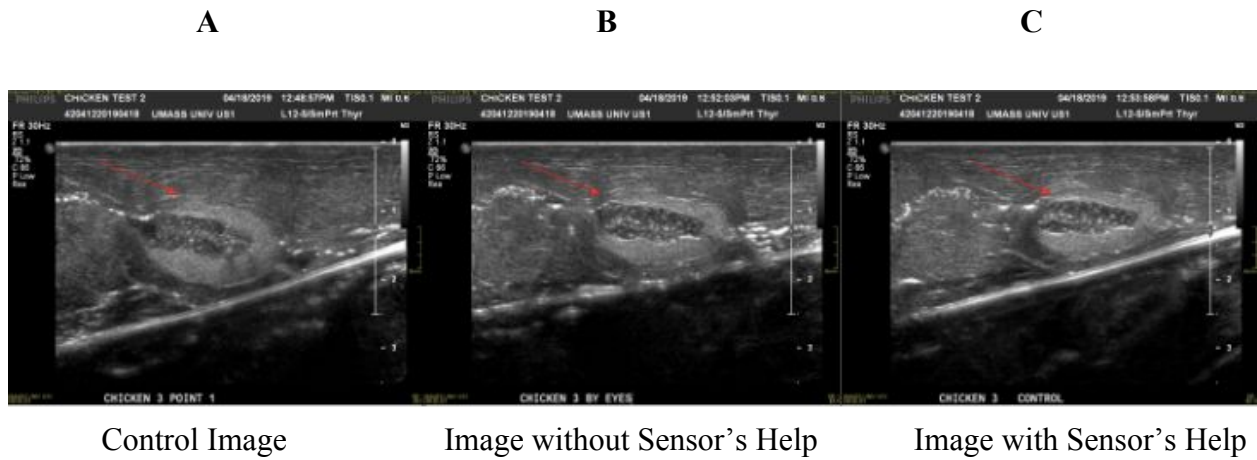

Figure 5.5: Ultrasound Images taken A) during the Control Experiment, B) without the Sensor's Coordinates, and C) with the Sensor's Coordinates.

## **Chapter 6: Final Design and Verification**

### **6.1 Final Design Overview**

#### **6.1.1 Sensor Case: Version 1**

The first area the team needed to address was the protection of the sensor. This is due to the sensor's sensitivity and be easily damaged. To protect the sensor from damage that could result of daily use, the team designed and developed a protective case. Using Solidworks, the team designed the case using 3D printing materials. In combination with an Ultimaker 3 and polylactide (PLA) material, the team was able to print a case and a lid with support and protection for our device. The entire case was 60mm by 64mm by 23mm. It has three circular pillars that measured 2.1mm in diameter and a height of 6mm that holds the sensor in place. In addition, three rectangular holes of 20mm by 20mm (two located on the case, one on the lid) and a single 17mm by 18.5mm were built in to prevent heat from the the sensor to cause any defects to the PLA. To get access to the usb port, a rectangular hole of 15mm by 10mm was placed on one side of the case where the port is attached. The lid had dimensions of 56mm by 60mm by 10mm. The entire case was fastened to the ultrasound probe using velcro.

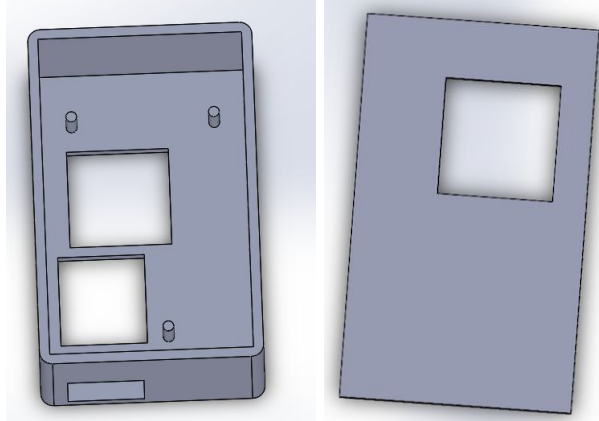

Figure 6.1: SolidWork Models of the Case and Lid

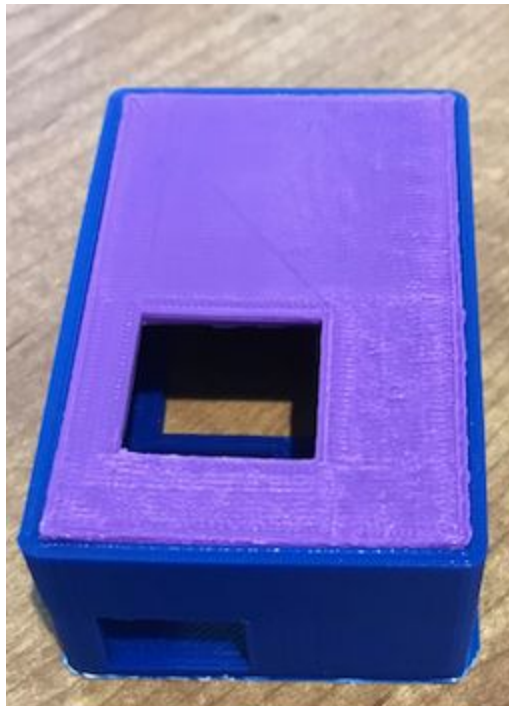

Figure 6.2: 3D Printed Case and Lid

### 6.1.2 Sensor Case: Version 2

When the team went to Umass Memorial Hospital to see whether the 3D printed case would fit on the ultrasound probe, the team found that the case was too big to place on the probe, without altering the ultrasound technician grip.

In the second iteration of design, the team wrapped the sensor around with medical tape to protect the sensor from damage. The prototype is shown in Figure 6.3. This case was used when the team performed the tolerance angle testing described in Section 5.5.



Figure 6.3: Case with Medical Tape on Ultrasound Probe

### 6.1.3 Graphic User Interface

To store the euler angle data, the team developed a graphical user interface (GUI) in MATLAB and used reference code to assist the team in importing and sorting the Open Sound Control (OSC) messages coming from the common User Datagram Protocol (UDP) port of the computer and connected IMU sensor. The final setup of the GUI is shown in Figure 6.4, and the section of the MATLAB code used to develop the GUI can be seen in Appendix C. The “static text” disappeared when angle data is being received in MATLAB. Functional push buttons were also designed in the GUI. There is an “open” button that opened a UDP port which was entered by a user. This was utilized so data from the IMU sensor could be accepted. The UDP port was remembered by the GUI and did not need to be changed once a user puts it in for the first time, but had the ability to be changed if desired. Once the UDP port was opened, and the sensor was being recorded, there was a visual display of the sensor moving in the quaternion coordinate plane. The quaternion coordinates were converted and displayed in euler angles (in radians) in real time using the *quat2eul* function in MATLAB. The angles were then converted to degrees. When the sensor was orientation were the user wants to take an image, there is a save button that stores the latest quaternion coordinates in the MATLAB base workspace. When the ultrasound technician wanted to return to position at which an ultrasound image was taken, they could find the orientation by looking at the previous image and then they can click the “return” button. This would provide them with the saved roll, pitch, and yaw angles allowing them to adjust the orientation of the sensor to match the displayed angles.

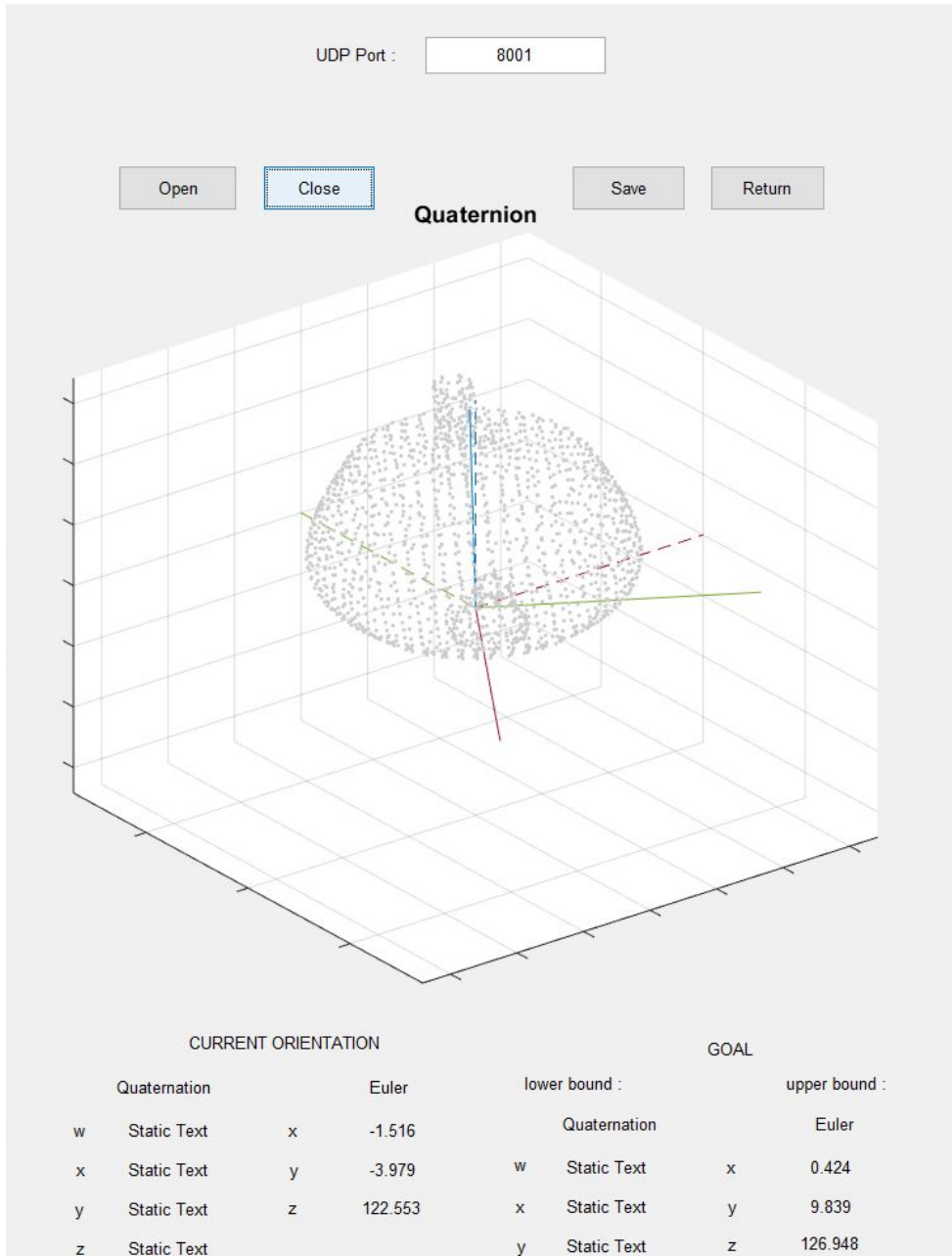

Figure 6.4: GUI of Storing Euler Angles

## **6.2 Final Design Impact**

### **6.2.1 Economics**

As mentioned in the introduction section of this report, 15 to 20 percent of patients are misdiagnosed during an ultrasound [3] [4]. The device developed by the team was intended to minimize the number of patients who are misdiagnosed during an ultrasound. As a result, this could reduce the number of appointments patients need to have an ultrasound redone and meet with their radiologists. Reducing the number of appointments could minimize the amount of money patients and insurance companies would have to spend, freeing up additional appointments for other patients. This particular device would cost over \$300. This sensor has very high accuracy and also has a GUI that was developed to allow for easy interaction with ultrasound technicians. Even though the device is useful, the cost effectiveness must be weighed based on how much a particular clinic or hospital is able to spend. One other way that this device can be made cheaper is if a cheaper IMU/AHRS sensor was used and more of the signal processing was done by the team instead of getting a sensor with all of the capability included. For the limited time frame of the project, it was decided to get a sensor with this capability included even though the price was higher.

### **6.2.2 Environmental Impact**

The utilization of this item does not have major/abrupt impacts on the environment. The natural effect of the item was determined by the procedures operated by the manufacturers of the sensor. This implied that any expansion or decline in environmental effect related sensor system



will be due the procedures that the manufacturers. The rate at which the sensors are made can produce more or less waste. The GUI developed for this sensor could cause computers or PCs to lose battery faster or need to be charged more often, but the sensor itself does not release anything into the air besides heat.

### **6.2.3 Societal Influence**

As mentioned throughout this report, this sensor could be very useful in hospitals and medical offices. This was to minimize the number of patients who were misdiagnosed during an ultrasound. This approach could raise awareness that misdiagnosis in ultrasound is a problem which could convince hospitals and medical offices to use the sensor during an ultrasound. On a wider scale, this approach could potentially lead to sensor usage in other imaging applications such as Cat Scans, MRIs, and Xrays.

### **6.2.4 Political Ramifications**

Due to the nature of this project, there are few political ramifications. One possible political ramification is the push for better healthcare. This could be due to the reduction of a misdiagnosed patient. Moreover, usage of our team's device would be supported. If clinical trials go successfully, it would have the potential of being commercialized to hospitals and medical officers.

### **6.2.5 Ethical Concerns**

The main intention of the sensor was for ultrasound technicians to move the sensor freely along the patient's body where the ultrasound probe is being conducted to allow for more

accurately reproduced ultrasound images. Since the team's sensor was noninvasive, ethical concerns were slightly less of a focus although there are still a few. One possible ethical concern related to the ultrasound procedure is that someone may take the patient's data and ultrasound images without the patient's permission, violating HIPAA compliance [60]. The team took precautions that follow HIPAA compliance to prevent this from happening. The saved orientation data in the GUI should be introduced into the workspace from a file. This file should come from the hospital's own confidential electronic patient data information system. Also, the MATLAB program used for the GUI does not save the ultrasound images. It can only get access to the orientation data. Another ethical concern could be the introduction of machine influence and the supposed reduction of human influence in the process of ultrasonography. This can cause some people to become more worrisome when it is believed that a machine has more influence over the results of their test. A lot of people might become less trustworthy while others become more trustworthy. It is important that this device is used as an assistant for ultrasound technicians, not as a stand alone method for taking ultrasound images. The ultrasound technicians should still be knowledgeable about how to reproduce an ultrasound image, but this device should help them to accomplish it faster and increase the accuracy. It is important that the ultrasound technician explains this to the patient to alleviate some of the worry.

### **6.2.6 Health and Safety Issues**

The orientation coordinates of the sensor allowed the ultrasound technicians to reproduce images at the area of interest that were comparable to the previous image. As mentioned in section 6.2.5, the patient's coordinates will be in the hospital's records. Therefore, facilities at

hospitals have to obey HIPAA regulations since information is private and needs to be protected from those not involved in radiology [60]. Additionally, the team conducted tests only on chicken breast and would need IRB approval for clinical trials. By performing these tests, it could get FDA approval, so the device could be safe for use on humans. Finally, as an electronic device, the device can be damaged and destroyed if the device is near any electrical plugs, anything magnetic, wet or metal. Also, as the sensor tends to generate heat, it could potentially cause damage to other materials. Any material that is touching the sensor should have a high melting point to prevent any damage on the material.

### **6.2.7 Manufacturability**

Since the team's goal was to make a proof of concept, focus was put on the necessary components of the sensor rather than the cost of it. Although the NGIMU unit could be manufactured easily, it was expensive. The cost of the unit is about \$300. If allowed more time the team would have purchased cheaper sensor. However, the accuracy might be compromised due to the caliber of the project. Cheaper Inertial Measurement Units may vary but would take longer to build. That approach would lower the manufacture and would be more affordable and accessible. By making the appropriate adjustments to the sensor, the sensor could be mass produced and sold to hospitals and other healthcare facilities. This usually involves a vendor-neutral party that helps the hospital examine the ownership and total cost of equipment [61].

### **6.2.8 Sustainability**

The sensor requires a battery that needs to be charged in order for the sensor to work wirelessly. A charger was ordered and the team configured it to fit the sensors battery. This enables the battery to last a much longer time than it normally would. If the battery completely stopped working, the old battery would need to be disposed of and a new battery would need to be replaced. Eventually this can happen, making the battery unsustainable, but with a charger, the life of the battery can be sustained much longer.

## **Chapter 7: Discussions**

### **7.1 Accuracy of the Sensor's Gyroscope**

In the graph shown in Figure 5.1, the line of best fit was  $y = 1.0115x - 1.143$ , and the line had an  $R^2$  value of 0.9997. That  $R^2$  value shows that 99.97% of data can be described as a linear relationship, which is what the team was looking for since the electric protractor should have a value that is similar to angle value of the sensor in the pitch direction. This also means that the team validated the accuracy of the sensor's gyroscope measurements.

In the residual plot in Figure 5.2, the team wanted to determine how far off the sensor's gyroscope value was compared to the value of the electric protractor, which was determined to be under three degrees. Since the sensor needed to be within the  $4.4^\circ$  mentioned in Section 3.2, it validated that the sensor did not experience any error above  $4.4^\circ$ .

### **7.2 Reproducibility Angle Testing with Sensor**

After calculating the absolute error of the coordinates in Table 5.1, a normal distribution test was performed to see if the absolute error data with and without the sensor's help followed the normal distribution despite having a low sample size. Both sets of data followed a normal distribution, so a two tailed unpaired test was performed to see if there was a significant difference with a 5% significance level between the absolute error data with and without the sensor's help. A p-value of 0.0025 was determined, which means that there was a significant difference between the absolute errors. This means that using the sensor's coordinates helped the ultrasound technician reproduce the ultrasound image recorded during the control round. In

addition, the absolute error with the sensor's help was below the  $1^\circ$ , which means the team met and surpassed the  $4.4^\circ$  tolerance described in section 3.2.

In the bar graph in Figure 5.3, the light blue bar graphs show there is much less error in the angle coordinates with the help of the sensor compared to the dark blue bar graphs that represent the absence of the sensor's help. The error bars also represent the standard of mean that is equally distributed in both directions. The average absolute error without the sensor's help for chicken breast test one, two, and three were  $2.33 \pm 1.25$  degrees,  $4.20 \pm 1.17$  degrees,  $5.53 \pm 2.78$  degrees respectively. The average absolute error with the sensor's help for chicken breast test one, two, and three were  $0.17 \pm 0.03$  degrees,  $0.30 \pm 0.21$  degrees,  $0.30 \pm 0.15$  degrees respectively. Overall, the sensor's coordinates significantly reduced the error in reproducing the image.

The time measured during the methods with and without the sensor did not validate whether the sensor's coordinates reduced the time it took to reproduce the image during the control experiment. However, the ultrasound technician stated to the team that she was comfortable using the sensor during the third trial. Each user may need more training than others in order to get comfortable using the sensor. The team would need to conduct more trials to find out whether the sensor reduces the amount of time to produce an image.

Despite the ultrasound images shown in Figure 5.4 being similar to each other, the size of the olive did increase after performing the three trials on each chicken breast. This is due to the fact that the same olive was used for each chicken breast, and when the ultrasound probe was on the olive, the size of the olive compressed or became squished. Performing ultrasound testing and recording the size of a mass in humans would avoid any damage to the tissues.

## **Chapter 8: Conclusions and Recommendations**

### **8.1 Conclusions**

In conclusion, the team validated the reproducibility of ultrasound images using the Next Generation IMU sensor. The team determined that the sensor was giving accurate angle measurements, and the residual was within the  $4.4^\circ$  the team proposed. The orientation of the sensor provided accurate angle measurements, and the orientation methods could help ultrasound technicians find the position and orientation of the ultrasound probe which was validated when a two tailed unpaired t-test was performed, and the absolute error with the sensor's coordinates were under  $4.4^\circ$ . The ability to detect the exact position and orientation of the sensor can allow images can be consistently produced. This is proven by the absolute error test that was mentioned in Chapter 5.3. This could allow radiologists and other physicians to use multiple images to make conclusions including diagnosis, changes from the images, and any recommend medications.

### **8.2 Recommendations**

One future recommendation for the sensor is improve the accuracy of the position by combining another sensor or function with the IMU to eliminate the effects of gravity and noise such as the Kalman Filter. By doing that, the position can be determined with higher accuracy. Another recommendation is to create an app or software on a computer or tablet for the ultrasound technicians that implements the team's method to detect the position and orientation of the ultrasound probe. This would encompass the MATLAB capabilities of the GUI for user

feedback and the signal processing techniques. This would make for a more simplistic setup for the ultrasound orientation device. Another recommendation is to use a silicone case for the sensor in order to provide a slimmer profile for the ultrasound probe. Furthermore, the location of the screen that would provide a reference image of the previous ultrasound picture should be located side by side to better estimate the position of foreign object. Finally, a long-term recommendation would include performing clinical trials on humans to see whether the sensor could be commercialized to both hospitals and other medical offices. This would increase reproducibility results compared to the ones conducted on chicken breasts although it is common practice to train ultrasound technicians with this model. This is due to variability of shifting that can not be controlled. This also included the an increase of area from the olive due to deformation caused by pressure exerted on the breast and air pockets. It was recommended that our device would be used for identifying superficial foreign objects such as breast tissue and the thyroid. It would be hard for the team's sensor to detect foreign objects in deep structures that are more than a few centimeters deep.



## References

- [1] Radiologyinfo.org. (n.d.). *Ultrasound (Sonography)*. [online] Available at: <https://www.radiologyinfo.org/en/info.cfm?pg=genus> [Accessed 9 Sep. 2018].
- [2] Sippel, S., Muruganandan, K., Levine, A. and Shah, S. (2018). *Review article: Use of ultrasound in the developing world*. [online] Intjem.biomedcentral.com. Available at: <https://intjem.biomedcentral.com/track/pdf/10.1186/1865-1380-4-72> [Accessed 14 Sep. 2018].
- [3] Cipollini, F. and Cipollini, M. (2015). A critical evaluation in the delivery of the ultrasound practice: the point of view of the Internal Medicine hospitalist. *Italian Journal of Medicine*, 9(1), pp.1-4.
- [4] MarketWatch. (2018). *Ultrasound Devices Market Global Industry Demand, Size, Growth Research Report By 2022*. [online] Available at: <https://www.marketwatch.com/press-release/ultrasound-devices-market-global-industry-demand-size-growth-research-report-by-2022-2018-04-17> [Accessed 14 Sep. 2018].
- [5] Cipollini, F. and Cipollini, M. (2018). *A critical evaluation in the delivery of the ultrasound practice: the point of view of the Internal Medicine hospitalist* | *Italian Journal of Medicine*. [online] Italjmed.org. Available at: <https://www.italjmed.org/index.php/ijm/article/view/itjm.2015.522/646> [Accessed 14 Sep. 2018].
- [6] Evans, N. (2002). *Echocardiographic Misdiagnosis and Ultrasound Skills*. [online] Wiley Online Library. Available at: <https://onlinelibrary.wiley.com/doi/full/10.1046/j.1440-1754.2002.0796e.x> [Accessed 14 Sep. 2018].
- [7] Search.proquest.com. (2016). *Log In - ProQuest*. [online] Available at: [https://search.proquest.com/docview/1852739563?rfr\\_id=info%3Axri%2Fsid%3Aprimo](https://search.proquest.com/docview/1852739563?rfr_id=info%3Axri%2Fsid%3Aprimo) [Accessed 17 Sep. 2018].
- [8] Huang, Q. and Zeng, Z. (2017). A Review on Real-Time 3D Ultrasound Imaging Technology. *BioMed Research International*, 2017, pp.1-20.

- [9] E. M. Ruoti and G. Stasi, "Ultrasound Quality is Operator Dependent," *Italian Journal of Medicine*, vol. 9, no. 1, Mar. 2014.
- [10] R. Housden, G. M. Treece, A. H. Gee, and R. W. Prager, "Calibration of an orientation sensor for freehand 3D ultrasound and its use in a hybrid acquisition system," *BioMedical Engineering OnLine*, vol. 7, no. 1, Jan. 2008.
- [11] B. Bolsterlee, S. Gandevia and R. Herbert, "Effect of Transducer Orientation on Errors in Ultrasound Image-Based Measurements of Human Medial Gastrocnemius Muscle Fascicle Length and Pennation", *PLOS ONE*, vol. 11, no. 6, 2016.
- [12] *How Ultrasound Works*. [Online]. Available: [https://www.physics.utoronto.ca/~jharlow/teaching/phy138\\_0708/lec04/ultrasoundx.htm](https://www.physics.utoronto.ca/~jharlow/teaching/phy138_0708/lec04/ultrasoundx.htm). [Accessed: 24-Sep-2018].
- [13] "MB7760 4-20SC-MaxSonar-WR - MaxBotix Inc.", *MaxBotix Inc.*, 2018. [Online]. Available: [https://www.maxbotix.com/Ultrasonic\\_Sensors/MB7760.htm](https://www.maxbotix.com/Ultrasonic_Sensors/MB7760.htm). [Accessed: 24-Sep- 2018].
- [14] Coward, C. (2017). Converting a 2D Ultrasound Machine to 3D for Just \$10. [online] Hackster Blog. Available at: <https://blog.hackster.io/converting-a-2d-ultrasound-machine-to-3d-for-just-10-1d1ed92dbfc2> [Accessed 24 Sep. 2018].
- [15] Poulsen, C. (2018). Development of a Positioning System for 3D Ultrasound. [online] Digital WPI. Available at: <https://digitalcommons.wpi.edu/etd-theses/1064/> [Accessed 23 Sep. 2018].
- [16] Error, I., Radiology, D., (DRLs), P. and Radiology, D. (2018). Increase Your Awareness and Understanding of Radiologic Error - Everything Rad. [online] Everything Rad. Available at: <https://www.carestream.com/blog/2017/05/15/increase-awareness-understanding-radiologic-error/> [Accessed 24 Sep. 2018].
- [17] Kimura, B., Fowler, S., Nguyen, D., Amundson, S. and DeMaria, A. (2018). Detection of early carotid arterial atherosclerosis by briefly trained physicians using a hand-held ultrasound device. [online] Science Direct. Available at:

- <https://www.sciencedirect.com/science/article/pii/S0002914903005502> [Accessed 23 Sep. 2018].
- [18] E. M. Ruoti and G. Stasi, "Ultrasound Quality is Operator Dependent," *Italian Journal of Medicine*, vol. 9, no. 1, Mar. 2014.
- [19] Shah, S., Bellows, B., Adedipe, A., Totten, J., Backlund, B. and Sajed, D. (2018). Perceived barriers in the use of ultrasound in developing countries. [online] NCBI. Available at: <https://www.ncbi.nlm.nih.gov/pmc/articles/PMC4485671/> [Accessed 14 Sep. 2018].
- [20] M. Bénard, J. Becher, J. Harlaar, P. Huijing and R. Jaspers, "Anatomical information is needed in ultrasound imaging of muscle to avoid potentially substantial errors in measurement of muscle geometry", *Muscle & Nerve*, vol. 39, no. 5, 2009.
- [21] J. Whittaker, M. Warner and M. Stokes, "Induced Transducer Orientation During Ultrasound Imaging: Effects on Abdominal Muscle Thickness and Bladder Position", *Ultrasound in Medicine & Biology*, vol. 35, no. 11, pp. 1803-1811, 2009.
- [22] V. P. Buil, P. R. Detmer, J.-M. Jong, and X.-N. Li, "Position sensor in ultrasound transducer probe," 29-Apr-2003.
- [23] Y. Peng, Y. M. Shkel, and T. J. Hall, "A Tactile Sensor for Ultrasound Imaging Systems," *IEEE Sensors Journal*, vol. 26, no. 4, pp. 1044–1053, Feb. 2015.
- [24] Tatar, J. R. Mollinger, R. C. Den Dulk, W. A. van Duyl, J. F. L. Goosen and A. Bossche, "Ultrasonic sensor system for measuring position and orientation of laparoscopic instruments in minimal invasive surgery," *2nd Annual International IEEE-EMBS Special Topic Conference on Microtechnologies in Medicine and Biology. Proceedings (Cat. No.02EX578)*, Madison, WI, USA, 2002, pp. 301-304.
- [25] "Position Sensors", [Cecas.clemson.edu](https://cecas.clemson.edu). [Online]. Available: [https://cecas.clemson.edu/cvel/auto/sensors/position\\_sensor.html](https://cecas.clemson.edu/cvel/auto/sensors/position_sensor.html). [Accessed: 24- Sep-2018]
- [26] K. Christiansen and A. Shalamov, "Motion Sensors Explainer", *W3.org*, 2017. [Online]. Available: <https://www.w3.org/TR/motion-sensors/>. [Accessed: 23- Sep- 2018].

- [27] "A beginner's guide to accelerometers", *Dimensionengineering.com*. [Online]. Available: <https://www.dimensionengineering.com/info/accelerometers>. [Accessed: 23- Sep- 2018].
- [28] J. Evers, "Coriolis effect", *National Geographic Society*, 2018. [Online]. Available: <https://www.nationalgeographic.org/encyclopedia/coriolis-effect/>. [Accessed: 23- Sep- 2018]
- [29] A. Kostianen and M. Pozdnyakov, *Positive angular velocity directions around the defined axes of an iPhone*. 2018 [Online]. Available: [https://w3c.github.io/gyroscope/images/gyroscope\\_sensor\\_coordinate\\_system.svg](https://w3c.github.io/gyroscope/images/gyroscope_sensor_coordinate_system.svg). [Accessed: 23- Sep- 2018]
- [30] Z. Kasmi, Components' interaction. 2017 [Online]. Available: [https://www.researchgate.net/profile/Zakaria\\_Kasmi2/publication/316735831/figure/fig7/AS:668796826181632@1536464997122/Components-interaction\\_W640.jpg](https://www.researchgate.net/profile/Zakaria_Kasmi2/publication/316735831/figure/fig7/AS:668796826181632@1536464997122/Components-interaction_W640.jpg). [Accessed: 24- Sep- 2018]
- [31] Z. Kasmi, Magnetic indoor local positioning system (MILPS) principle.. 2018 [Online]. Available: [https://www.researchgate.net/profile/Zakaria\\_Kasmi2/publication/316735831/figure/fig2/AS:491504939606017@1494195317806/Magnetic-indoor-local-positioning-system-MILPS-principle\\_W640.jpg](https://www.researchgate.net/profile/Zakaria_Kasmi2/publication/316735831/figure/fig2/AS:491504939606017@1494195317806/Magnetic-indoor-local-positioning-system-MILPS-principle_W640.jpg). [Accessed: 24- Sep- 2018]
- [32] "Hall Effect Sensor and How Magnets Make It Works," *Basic Electronics Tutorials*, 09-Feb-2018. [Online]. Available: <https://www.electronics-tutorials.ws/electromagnetism/hall-effect.html>. [Accessed: 07-Oct-2018].
- [33] "Hall Effect Sensing and Application." [Online]. Available: <https://sensing.honeywell.com/hallbook.pdf>. [Accessed: 07-Oct-2018].
- [34] A. Solin, M. Kok, N. Wahlström, T. Schön and S. Särkkä, "Modeling and Interpolation of the Ambient Magnetic Field by Gaussian Processes", *Arxiv.org*, 2018. [Online]. Available: <https://arxiv.org/pdf/1509.04634.pdf>. [Accessed: 24- Sep- 2018]
- [35] J. Haverinen and A. Kemppainen, "Global Indoor self-localization based on the ambient magnetic field", 2009. [Online]. Available: [https://www.researchgate.net/publication/223594443\\_Global\\_Indoor\\_self-localization\\_based\\_on\\_the\\_ambient\\_magnetic\\_field](https://www.researchgate.net/publication/223594443_Global_Indoor_self-localization_based_on_the_ambient_magnetic_field). [Accessed: 24- Sep- 2018]

- [36] M. Kok, J. D. Hol, and T. B. Schön, "Using Inertial Sensors for Position and Orientation Estimation," *Foundations and Trends® in Signal Processing*, vol. 11, no. 1-2, pp. 1–153, 2017.
- [37] C. Combettes and V. Renaudin, Pedestrian Dead Reckoning (PDR) mechanization equations with handheld tri-axis inertial sensors and tri-axis magnetometers.. 2014 [Online]. Available: [http://www.mdpi.com/sensors/sensors-14-22864/article\\_deploy/html/images/sensors-14-22864f2-1024.png](http://www.mdpi.com/sensors/sensors-14-22864/article_deploy/html/images/sensors-14-22864f2-1024.png). [Accessed: 24- Sep- 2018]
- [38] B. Kimura, S. Fowler, D. Nguyen, S. Amundson and A. DeMaria, "Detection of early carotid arterial atherosclerosis by briefly trained physicians using a hand-held ultrasound device", *Science Direct*, 2018. [Online]. Available: <https://www.sciencedirect.com/science/article/pii/S0002914903005502>. [Accessed: 23-Sep- 2018].
- [39] V. Mazzari, "Ultrasound sensor ? high quality ultrasound sensors available now", *Génération Robots - Blog*, 2018. [Online]. Available: <https://www.generationrobots.com/blog/en/ultrasound-sensor-high-quality-ultrasound-sensors-available-now/>. [Accessed: 24- Sep- 2018].
- [40] "We're ISO: we develop and publish International Standards," *Developing standards*, 21-Aug-2018. [Online]. Available: <https://www.iso.org/standards.html>. [Accessed: 30-Sep-2018].
- [41] "LibGuides: Standards, Codes, & Specifications: What is a standard?," *Popular, Scholarly, or Trade? - LibGuides at University of Texas at Austin*. [Online]. Available: <https://guides.lib.utexas.edu/c.php?g=554840&p=3812748>. [Accessed: 30-Sep-2018].
- [42] "ACR PRACTICE PARAMETER FOR COMMUNICATION OF DIAGNOSTIC IMAGING FINDINGS," 2014. [Online]. Available: <https://www.acr.org/-/media/ACR/Files/Practice-Parameters/CommunicationDiag.pdf>. [Accessed: 30-Sep-2018].
- [43] "ACR PRACTICE PARAMETER FOR THE PERFORMANCE OF A BREAST ULTRASOUND EXAMINATION," 2016. [Online]. Available: <https://www.acr.org/-/media/ACR/Files/Practice-Parameters/US-Breast.pdf?la=en>. [Accessed: 30-Sep-2018].

- [44] “*Technical product documentation — Digital product definition data practices*,” 2015. [Online]. Available: <https://www.sis.se/api/document/preview/919772/>. [Accessed: 30-Sep-2018].
- [45] “*Technical drawings — General principles of presentation — Part 24: Lines on mechanical engineering drawings*,” 2014. [Online]. Available: <https://www.sis.se/api/document/preview/917051/>. [Accessed: 30-Sep-2018].
- [46] “*Geometrical product specifications (GPS) — Geometrical tolerancing — Tolerances of form, orientation, location and run-out*,” 2017. [Online]. Available: <https://www.sis.se/api/document/preview/921461/>. [Accessed: 30-Sep-2018].
- [47] “671-1985 - IEEE Standard Specification Format Guide and Test Procedure for Nongyroscopic Inertial Angular Sensors: Jerk, Acceleration, Velocity, and Displacement,” *IEEE-SA - The IEEE Standards Association - Home*. [Online]. Available: <https://standards.ieee.org/standard/671-1985.html>. [Accessed: 30-Sep-2018].
- [48] “1431-2004 - IEEE Standard Specification Format Guide and Test Procedure for Coriolis Vibratory Gyros,” *IEEE-SA - The IEEE Standards Association - Home*. [Online]. Available: <https://standards.ieee.org/standard/1431-2004.html>. [Accessed: 30-Sep-2018].
- [49] “1554-2005 - IEEE Recommended Practice for Inertial Sensor Test Equipment, Instrumentation, Data Acquisition, and Analysis,” *IEEE-SA - The IEEE Standards Association - Home*. [Online]. Available: <https://standards.ieee.org/standard/1554-2005.html>. [Accessed: 30-Sep-2018].
- [50] “2700-2014 - IEEE Standard for Sensor Performance Parameter Definitions,” *IEEE-SA - The IEEE Standards Association - Home*. [Online]. Available: <https://standards.ieee.org/standard/2700-2014.html>. [Accessed: 30-Sep-2018].
- [51] “Current Edition,” *DICOM Standard*. [Online]. Available: <https://www.dicomstandard.org/current/>. [Accessed: 30-Sep-2018].
- [52] “DICOM PS3.1 2018d - Introduction and Overview,” 2018. [Online]. Available: <http://dicom.nema.org/medical/dicom/current/output/pdf/part01.pdf>. [Accessed: 30-Sep-2018].

- [53] “Summary of the HIPAA Privacy Rule,” *HHS.gov*, 26-Jul-2013. [Online]. Available: <https://www.hhs.gov/hipaa/for-professionals/privacy/laws-regulations/index.html?language=en>. [Accessed: 30-Sep-2018].
- [54] H. Masoudi, R. Alimardani, M. Omid, S. S. Mohtasebi, and N. Noguchi, “Determination of Ultrasonic Sensor Ability for Use as Guidance Sensors of Mobile Robots,” *Sensors and Materials*, vol. 24, no. 3, pp. 115–126, Jan. 2012.
- [55] “HALL EFFECT SENSING AND APPLICATION.” [Online]. Available: <https://sensing.honeywell.com/hallbook.pdf>. [Accessed: 30-Sep-2018].
- [56] “Understanding Euler Angles,” *CH Robotics*. [Online]. Available: <http://www.chrobotics.com/library/understanding-euler-angles>. [Accessed: 24-Apr-2019].
- [57] “Angle and Distance Measurement Device using Arduino,” *Arduino Projects - Arduino based Distance and Angle Measurement Device*. [Online]. Available: <https://www.engineersgarage.com/contribution/angle-and-distance-measurement-device-using-arduino>. [Accessed: 16-Apr-2019].
- [58] “Home,” *Xsens 3D motion tracking*. [Online]. Available: <https://www.xsens.com/>. [Accessed: 16-Apr-2019].
- [59] “NGIMU,” – *x-io Technologies*. [Online]. Available: <http://x-io.co.uk/ngimu/>. [Accessed: 13-Apr-2019].
- [60] HHS Office of the Secretary, Office for Civil Rights and Ocr, “Privacy,” *HHS.gov*, 16-Apr-2015. [Online]. Available: <https://www.hhs.gov/hipaa/for-professionals/privacy/index.html>. [Accessed: 23-Apr-2019].
- [61] T. Dale Hockel, "Top 6 Things for Hospitals to Consider When Purchasing Capital Equipment, *Beckershospitalreview.com*, 2019. [Online]. Available: <https://www.beckershospitalreview.com/hospital-management-administration/top-6-things-for-hospitals-to-consider-when-purchasing-capital-equipment.html>. [Accessed: 23-Apr-2019].

## Appendix A: Residual Plots of the Raw and Roll Angles

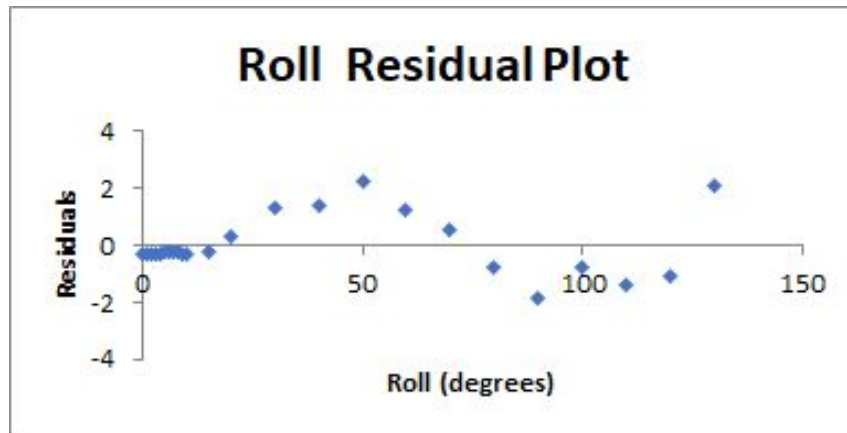

Residual Plot in the Roll Direction

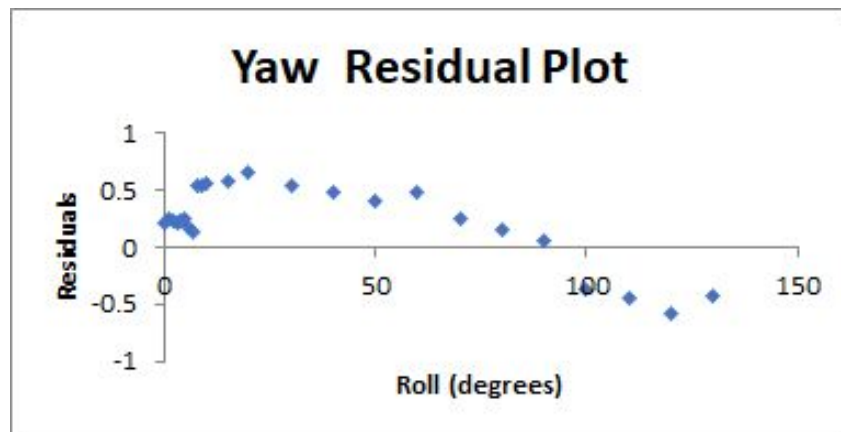

Residual Plot in the Yaw Direction



## Appendix B: Other Ultrasound Images from the Tolerance Angle Testing

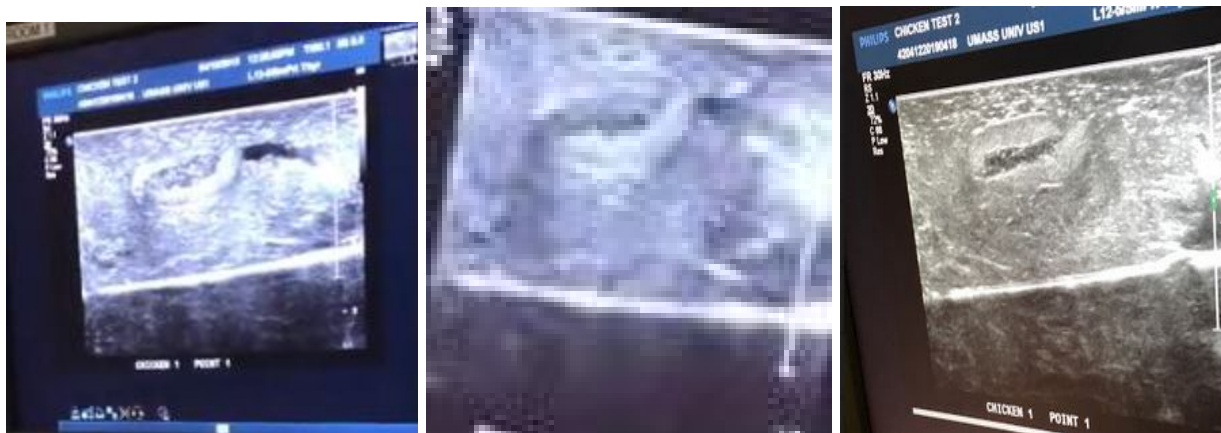

Control Image

Image without Sensor's Help

Image with Sensor's Help

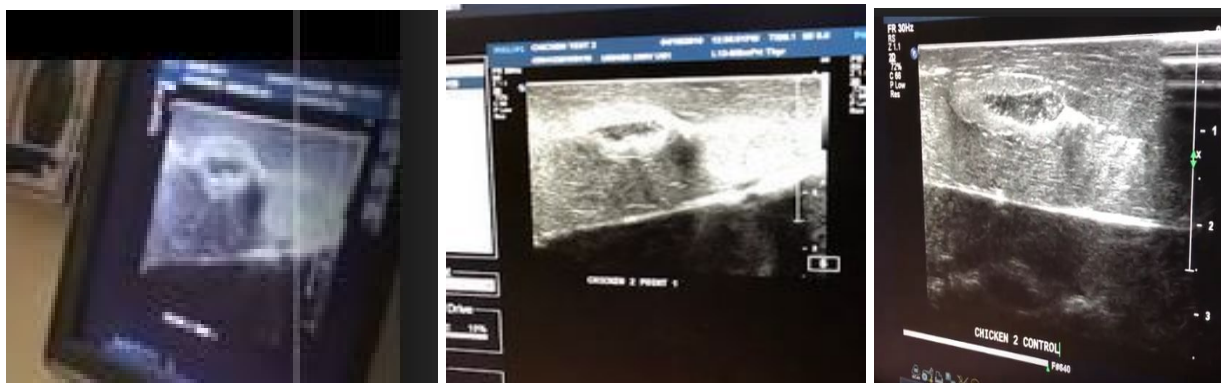

Control Image

Image without Sensor's Help

Image with Sensor's Help

## Appendix C: MATLAB Code for GUI

```
function varargout = gui2(varargin)
    % GUI2 MATLAB code for gui2.fig
    %     GUI2, by itself, creates a new GUI2 or
    %
    %     GUI2('CALLBACK',hObject,eventData,handles,...) calls the
local
    %     function named CALLBACK in GUI2.M with the given input
arguments.
    %
    %     GUI2('Property','Value',...) creates a new GUI2 or raises
the
    %     existing singleton*. Starting from the left, property
value pairs are
    %     applied to the GUI2 before gui2_OpeningFcn gets called.
An
    %     unrecognized property name or invalid value makes property
application
    %     stop. All inputs are passed to gui2_OpeningFcn via
varargin.
    %
    %     *See GUI2 Options on GUIDE's Tools menu. Choose "GUI2
allows only one
    %     instance to run (singleton)".
    %
    % See also: GUIDE, GUIDATA, GUIHANDLES

    % Edit the above text to modify the response to help gui2

    % Last Modified by GUIDE v2.5 18-Apr-2019 10:59:22

    % Begin initialization code - DO NOT raises the existing
    %     singleton*.
    %
    %     H = GUI2 returns the handle to a new GUI2 or the handle to
    %     the existing singleton*. EDIT
gui_Singleton = 1;
gui_State = struct('gui_Name',      mfilename, ...
```

```

        'gui_Singleton', gui_Singleton, ...
        'gui2_OpeningFcn', @gui2_OpeningFcn, ...
        'gui2_OutputFcn', @gui2_OutputFcn, ...
        'gui_LayoutFcn', [] , ...
        'gui_Callback', []);
if nargin && ischar(varargin{1})
gui_State.gui_Callback = str2func(varargin{1});
end

if nargout
[varargout{1:nargout}] = gui_mainfcn(gui_State, varargin{:});
else
gui_mainfcn(gui_State, varargin{:});
end
% End initialization code - DO NOT EDIT
end

% --- Executes just before gui2 is made visible.
function gui2_OpeningFcn(hObject, eventdata, handles, varargin)
% This function has no output args, see OutputFcn.
% hObject handle to figure
% eventdata reserved - to be defined in a future version of
MATLAB
% handles structure with handles and user data (see GUIDATA)
% varargin command line arguments to gui (see VARARGIN)

% Choose default command line output for gui
handles.output = hObject;

handles.gyroscopePlot = sensorPlot(handles.gyroscopeAxes, 500,
'Gyroscope');
handles.accelerometerPlot =
sensorPlot(handles.accelerometerAxes, 500, 'Accelerometer');
handles.magnetometerPlot = sensorPlot(handles.magnetometerAxes,
500, 'Magnetometer');
handles.quaternionPlot =
quaternionPlot(handles.quaternionAxes);

handles.timer = timer('Period', 0.02, 'ExecutionMode',
'fixedRate');
handles.timer.TimerFcn = {@timer_Callback, handles};
start(handles.timer);

```

```

    % Update handles structure
    guidata(hObject, handles);

    % UIWAIT makes gui wait for user response (see UIRESUME)
    % uiwait(handles.figure1);
end

% --- Outputs from this function are returned to the command line.
function varargout = gui2_OutputFcn(hObject, eventdata, handles)
    % varargout cell array for returning output args (see
    VARARGOUT);
    % hObject handle to figure
    % eventdata reserved - to be defined in a future version of
    MATLAB
    % handles structure with handles and user data (see GUIDATA)

    % Get default command line output from handles structure
    varargout{1} = handles.output;
end

function udpPortEditText_Callback(hObject, eventdata, handles)
    % hObject handle to udpPortEditText (see GCBO)
    % eventdata reserved - to be defined in a future version of
    MATLAB
    % handles structure with handles and user data (see GUIDATA)

    % Hints: get(hObject,'String') returns contents of
    udpPortEditText as text
    % str2double(get(hObject,'String')) returns contents of
    udpPortEditText as a double

end

% --- Executes during object creation, after setting all properties.
function udpPortEditText_CreateFcn(hObject, eventdata, handles)
    % hObject handle to udpPortEditText (see GCBO)
    % eventdata reserved - to be defined in a future version of
    MATLAB

```

```

    % handles empty - handles not created until after all
CreateFcns called

    % Hint: edit controls usually have a white background on
Windows.
    % See ISPC and COMPUTER.
    if ispc && isequal(get(hObject,'BackgroundColor'),
get(0,'defaultUicontrolBackgroundColor'))
        set(hObject,'BackgroundColor','white');
    end
end

% --- Executes on button press in openPushButton.
function openPushButton_Callback(hObject, eventdata, handles)
    % hObject handle to openPushButton (see GCBO)
    % eventdata reserved - to be defined in a future version of
MATLAB
    % handles structure with handles and user data (see GUIDATA)

    % Close all previous UDP sockets
    try
        fclose(instrfindall);
    catch
    end

    % Open UDP socket
    try
        udpPort = str2double(get(handles.udpPortEditText, 'String'));
        handles.udp = udp('255.255.255.255', 'Localport', udpPort,
'InputBufferSize', 4096);
        handles.udp.datagramReceivedFcn = {@processData_Callback,
handles};
        fopen(handles.udp);
    catch exception
        errordlg(exception.message);
    end

    % Update handles
    guidata(hObject, handles);
end

```

```

% --- Executes on button press in closePushButton.
function closePushButton_Callback(hObject, eventdata, handles)
    % hObject handle to closePushButton (see GCBO)
    % eventdata reserved - to be defined in a future version of
MATLAB
    % handles structure with handles and user data (see GUIDATA)

    try
        fclose(instrfindall);
    catch
    end
end

```

```

% --- Executes when user attempts to close figure1.
function figure1_CloseRequestFcn(hObject, eventdata, handles)
    % hObject handle to figure1 (see GCBO)
    % eventdata reserved - to be defined in a future version of
MATLAB
    % handles structure with handles and user data (see GUIDATA)

    try
        fclose(instrfindall);
    catch
    end
    stop(handles.timer);
    delete(handles.timer);

    % Hint: delete(hObject) closes the figure
    delete(hObject);
end

```

```

function processData_Callback(hObject, eventdata, handles)

    % Do nothing if socket closed
    if strcmp(handles.udp.Status, 'closed')
        return;
    end

    % Discard input buffer if overrun
    if handles.udp.BytesAvailable == handles.udp.InputBufferSize
        flushinput(handles.udp);
    end

```

```

warning('UDP input buffer overrun. ');
return;
end

% Read UDP packet
charArray = char(fread(handles.udp));

% Process OSC packet
oscMessages = getOscMessages(charArray);

% Process OSC messages
for oscMessagesIndex = 1:length(oscMessages)
    oscMessage = oscMessages(oscMessagesIndex);

    % Filter by OSC address
    switch oscMessage.oscAddress
        case '/sensors'

handles.gyroscopePlot.updateData([oscMessage.arguments{1},
oscMessage.arguments{2}, oscMessage.arguments{3}]);

handles.accelerometerPlot.updateData([oscMessage.arguments{4},
oscMessage.arguments{5}, oscMessage.arguments{6}]);

handles.magnetometerPlot.updateData([oscMessage.arguments{7},
oscMessage.arguments{8}, oscMessage.arguments{9}]);
        case '/quaternion'
            quaternionAxes = [oscMessage.arguments{1},
oscMessage.arguments{2}, oscMessage.arguments{3},
oscMessage.arguments{4}];
            handles.quaternionPlot.updateData(quaternionAxes);

        % updating quaternation values in the GUI2 text boxes
            set(handles.text5, 'String',
num2str(round(oscMessage.arguments{1}, 3)));
            drawnow;
            set(handles.text6, 'String',
num2str(round(oscMessage.arguments{2}, 3)));
            drawnow;
            set(handles.text7, 'String',
num2str(round(oscMessage.arguments{3}, 3)));
            drawnow;
    end
end

```

```

        set(handles.text8, 'String',
num2str(round(oscMessage.arguments{4}, 3)));
        drawnow;
        % convert to euler coordinates & update values
        eu = quat2eul(quaternionAxes, 'XYZ');
        eul = eu.*(180/pi);
        set(handles.text16, 'String', num2str(round(eul(1),
3)));
        drawnow;
        set(handles.text17, 'String', num2str(round(eul(2),
3)));
        drawnow;
        set(handles.text21, 'String', num2str(round(eul(3),
3)));
        drawnow;

        case '/temperature'
            % This message is currnelty unhandled
        case '/humidity'
            % This message is currnelty unhandled
        case '/battery'
            % This message is currnelty unhandled
        otherwise
            warning(['Unhandled OSC address received: '
oscMessage.oscAddress]);
        end
        end
end

```

```

function timer_Callback(hObject, eventdata, handles)
    handles.gyroscopePlot.updatePlot();
    handles.accelerometerPlot.updatePlot();
    handles.magnetometerPlot.updatePlot();
    handles.quaternionPlot.updatePlot();
    drawnow;
end

```

```

% %% SAVE BUTTON %% --- Executes on button press in pushbutton5.
function pushbutton5_Callback(hObject, eventdata, handles)
% hObject handle to pushbutton5 (see GCBO)

```



```

 eventdata reserved - to be defined in a future version of MATLAB
 handles structure with handles and user data (see GUIDATA)
 try
     fclose(instrfindall);
 catch
 end

 charArray = char(fread(handles.udp));
 oscMessages = getOscMessages(charArray); % process osc packet

 for oscMessagesIndex = 1:length(oscMessages)
     oscMessage = oscMessages(oscMessagesIndex);

     switch oscMessage.oscAddress
         case '/quaternion'
             % quarternation w x y z
             qua = [oscMessage.arguments{1},
 oscMessage.arguments{2}, oscMessage.arguments{3},
 oscMessage.arguments{4}];
             assignin('base', 'qua', qua);
         end
     end
 end

 % --- Executes on button press in pushbutton6.
 function pushbutton6_Callback(hObject, eventdata, handles)
 % hObject handle to pushbutton6 (see GCBO)
 % eventdata reserved - to be defined in a future version of MATLAB
 % handles structure with handles and user data (see GUIDATA)

 % get variables from base workspace & assign new variable names
 qu = evalin('base', 'qua');

 % display previously stored value(GOAL: Quarternation)
 set(handles.text23, 'String', num2str(round(qu(1), 3)));
 set(handles.text24, 'String', num2str(round(qu(2), 3)));
 set(handles.text25, 'String', num2str(round(qu(3), 3)));
 set(handles.text37, 'String', num2str(round(qu(4), 3)));
 % display previously stored value(GOAL: Euler)
 eul2 = quat2eul(qu, 'XYZ');
 eul3 = eul2.*(180/pi);

```

```

set(handles.text28, 'String', num2str(round(eul3(1), 3)));
set(handles.text29, 'String', num2str(round(eul3(2), 3)));
set(handles.text33, 'String', num2str(round(eul3(3), 3)));

% Coordinates of first ultrasound (w,x,y,z) = "qu"
% Lower bound at 10% tolerance
lb = qu - abs(qu * 0.5);
% 1st element is w, 2nd element is x, 3rd element is y, 4th element
is z
lb1 = lb(1); lb2 = lb(2); lb3 = lb(3); lb4 = lb(4);
% upper bound at 10% tolerance
ub = qu + abs(qu * 0.5);
% 1st element is w, 2nd element is x, 3rd element is y, 4th element
is z
ub1 = ub(1); ub2 = ub(2); ub3 = ub(3); ub4 = ub(4);

%display in GUI
set(handles.text41, 'String', num2str(lb));
set(handles.text42, 'String', num2str(ub));
End

```