

April 2019

# Impact Absorbing Wrist Guard for Snowboarders

Cole O. Godzinski

*Worcester Polytechnic Institute*

Hannah Lee Modelski

*Worcester Polytechnic Institute*

Kyle James Whittaker

*Worcester Polytechnic Institute*

Marc LaBahn

*Worcester Polytechnic Institute*

Follow this and additional works at: <https://digitalcommons.wpi.edu/mqp-all>

---

## Repository Citation

Godzinski, C. O., Modelski, H. L., Whittaker, K. J., & LaBahn, M. (2019). *Impact Absorbing Wrist Guard for Snowboarders*. Retrieved from <https://digitalcommons.wpi.edu/mqp-all/7069>

This Unrestricted is brought to you for free and open access by the Major Qualifying Projects at Digital WPI. It has been accepted for inclusion in Major Qualifying Projects (All Years) by an authorized administrator of Digital WPI. For more information, please contact [digitalwpi@wpi.edu](mailto:digitalwpi@wpi.edu).



# WPI

## **Impact Absorbing Wrist Guard for Snowboarders**

**A Major Qualifying Project**

**Submitted to the Faculty of**

**WORCESTER POLYTECHNIC INSTITUTE**

**In partial fulfillment of the requirements for the**

**Degree of Bachelor of Science**

**In Mechanical Engineering**

**Submitted By:**

**Cole Godzinski**

**Marc LaBahn**

**Hannah Modelski**

**Kyle Whittaker**

**Date Submitted: 4/25/2019**

**Advisor: Fiona Levey**

## **Abstract:**

Snowboarding has become an increasingly popular winter sport. This rise in popularity has resulted in a higher number of wrist injuries due to the tendency of snowboarders to fall with outstretched hands. Commercially available wrist guards are restrictive, bulky and simply transfer the impact force away from the wrist to the forearm and elbow. Consequently, many snowboarders do not wear wrist guards. The goal of this project was to increase use of wrist protective equipment and decrease wrist fractures by creating a low profile, non-restrictive design with superior impact absorption capabilities. The final prototype incorporated removable individual cells of a shear-thickening polymer in an all-in-one protective winter glove liner. The flexible and slim-fitting design increased the comfort of the user. Drop weight impact testing demonstrated impact force absorption in a simulated fall of 61-68% within a temperature range of -4 to 68 degrees Fahrenheit.

## **Acknowledgments:**

We first would like to extend a special thanks to our advisor, Fiona Levey, for providing us with the direction and comments necessary to create a successful prototype and Major Qualifying Project.

We would like to thank Adriana Hera for helping us conduct ANSYS simulations and holding tutorials for us.

We also would like to thank the Civil Engineering Department, specifically Russell Lang, for allowing us to use the Instron Dynatup 8250 machine in their facilities.

Lastly, we would like to thank the Mechanical Engineering department for providing the opportunity for us to complete an exciting project and answering any questions we had.

# Table of Contents:

<b>Abstract:</b>	<b>2</b>
<b>Acknowledgments:</b>	<b>3</b>
<b>Table of Contents:</b>	<b>4</b>
<b>List of Figures:</b>	<b>6</b>
<b>List of Tables:</b>	<b>7</b>
<b>Chapter 1: Introduction</b>	<b>8</b>
<b>Chapter 2: Literature Review</b>	<b>9</b>
2.1 Snowboarding Demographics and Injury Sites	9
2.2 Analysis of Wrist Fracture	9
2.3 Mechanics of Falling	11
2.3.1 Analysis of Forward and Backward Falls	11
2.3.2 Pressure Distribution over the Palm Region During Falls	13
2.4 Current Protection	14
2.5 Studies on Wrist Guards	15
2.6 Potential Materials for Improvement to Impact Force Absorption and Dispersion	16
2.6.1 Shear Thickening Fluids	17
2.6.2 Zoombang Protective Gear	17
<b>Chapter 3: Design Process</b>	<b>19</b>
3.1 Design Goals and Criteria	19
3.2 Preliminary Design	20
3.2.1 Manufacturability of Preliminary Design	25
3.3 Final Design	27
3.3.1 Impact absorption prototype design	27
3.3.2 ANSYS Force Testing	28
3.3.3 Manufacturing, Encapsulation, and Attachment Methods	32
<b>Chapter 4: Testing Procedure and Results</b>	<b>35</b>
4.1 Instron Dynatup 8250 Set-up	35
4.2 Standardization of Testing	35
4.3 Force Estimation	36
4.4 Impact Absorption Comparison Test	37
4.4.1 Procedure	37

4.5.2 Results	37
4.5 Testing for prototype performance after exposure to different temperatures	39
4.5.1 Procedure	39
4.5.2 Results	40
4.6 Testing for Flexibility	41
<b>Chapter 5: Analysis and Discussion</b>	<b>42</b>
<b>Chapter 6: Conclusions and Recommendations</b>	<b>43</b>
<b>Chapter 7: Bibliography</b>	<b>44</b>
<b>Appendix I: Examples of Commercially Available Wrist Guards</b>	<b>47</b>
<b>Appendix II: SolidWorks Drawings of Preliminary Design</b>	<b>49</b>

## List of Figures:

Figure 1. Distal radius fractures .....	9
Figure 2. Wrist fractures caused by hyperextension and radial abduction.....	10
Figure 3. Position of a snowboarder's feet .....	11
Figure 4. Results from a study of backward and forward falls from a low, medium, and high height [20]	12
Figure 5. Left: MBS model including human model, a model of a ski slope and a model of a snowboard. Right: Predicted contact forces in the Articulatio radiocarpalis, the Articulatio ulnocarpali and the Articulatio humeroulnaris .....	13
Figure 6. Predicted simulation backward fall and forward fall of the human model.....	13
Figure 7. Three danger zones across the palm [22] .....	14
Figure 8. Force distributions for each danger zone with respect to padding, impact angle and BMI of the subject [22].....	14
Figure 9. Different types of wrist protection.....	15
Figure 10. Force versus time graph of Zoombang padding in comparison with other commercially available sports padding [39] .....	18
Figure 11. Preliminary design sketch.....	23
Figure 12. Preliminary design .....	24
Figure 13. Spring parameters and equations for desired deflection based on parameters .....	24
Figure 14. Solutions from above equations .....	25
Figure 15. Example mold for foam impregnation.....	26
Figure 16. Example design of Base 1 .....	27
Figure 17. Example design of Base 2 .....	28
Figure 18. Stress on Base 2 Design 10 of ANSYS simulation .....	29
Figure 19. Stress distribution of Base 1 design 4 of ANSYS simulation .....	30
Figure 20. Stress distribution of Base 1 design 9 of ANSYS simulation .....	30
Figure 21. Stress of Base 1 design 10 of ANSYS simulation.....	31
Figure 22. Final design .....	32
Figure 23. Polyethylene-encapsulated pad that burst after impact testing .....	33
Figure 24. Custom pad encapsulation .....	33
Figure 25. Custom pads in pockets of Men's large Burton Gore-tex glove liner.....	34
Figure 26. Instron Dynatup 8250 load cell .....	35
Figure 27. Force absorption for the Dakine guard versus the rubber block control .....	38
Figure 28. Average and standard deviation of the rubber block versus Dakine wrist guard .....	38
Figure 29. Comparison of impact force at three different temperatures .....	40
Figure 30. Peak impact force over multiple trials .....	40

## List of Tables:

Table 1. Studies on the effectiveness of commercial wrist guards and new prototypes .....	16
Table 2. Design matrix for five preliminary designs .....	20
Table 3. Pros and cons of each design .....	22
Table 4. Top 6 maximum stresses for each design of Base 1 (measured in Pascals).....	29
Table 5. Maximum stresses for design 4, 9, and 10.....	31



## Chapter 1: Introduction

Snowboarding has become an increasingly popular winter sport with snowboarders making up one-third of all slope users [1]. With this rise in popularity, injuries are becoming more prevalent. The addition of snowboarding to ski resorts increased the risk of injury at the resort overall [2]. Despite this, not all snowboarders wear protective equipment to reduce the risk of injury.

Snowboarders are more prone to upper-extremity injuries rather than lower-extremity injuries as in skiers [3,4,5]. According to multiple studies, nearly half of all upper extremity injuries experienced by snowboarders are wrist fractures [4,6]. Specifically, wrist injuries are most common in beginner snowboarders. Beginner snowboarders often travel at slower speeds than intermediate or expert snowboarders. This results in an innate reaction to outstretch the arms to break a fall [7]. Additionally, one study showed that almost 90% of injured snowboarders were under the age of 30, with the average age being 22.5 years old [4].

Although wrist guards have been shown to protect the wrist, there are many drawbacks of wrist guards. There is some evidence that traditional snowboarding wrist guards transfer force of the fall instead of absorbing force leading to injuries in the elbows, forearms, and shoulders [8]. Wrist guards are also bulky and uncomfortable; therefore, snowboarders show little interest in wearing these protective devices. Furthermore, wrist guard use is consistently declining where helmet and back protector use is increasing, giving motivation to revamp wrist guards to increase usage [9].

This project aimed to reduce wrist injuries during snowboarding falls by creating an ergonomic, impact-absorbing device that would effectively absorb impact forces and increase the likelihood of snowboarders to wear protective wrist guards. The project targeted beginner snowboarders that are young adults as this was the most prevalent age and skill group.

## Chapter 2: Literature Review

### 2.1 Snowboarding Demographics and Injury Sites

Studies conducted around the world provided information on the types of injuries associated with snowboarding, all of which concluded that the most common body regions injured for snowboarders are the upper extremities including the head, shoulders, elbows and wrists [3,4,5]. Furthermore, a few studies define the leading injury for all ages and skill levels as the wrist. Injury types range from serious fractures to minor sprains and bruises [5]. Fractures are the most common injury type sustained by snowboarders [3]. Specifically, wrist fractures, with distal radius fractures occurring most frequently, are the leading injury due to snowboarders falling with outstretched arms onto the snow [3, 10]. Despite the high frequency of wrist injuries, wrist guard use is relatively uncommon. A study, “The Use of Wrist Guards by Snowboarders in Switzerland”, interviewed 3791 snowboarders over six winter seasons (between 2002-2003 and 2009-2010) regarding their use of wrist guards [9]. The use of wrist guards was at its highest in 2004 at about 40%, and decreased to 26% in 2009. The three most common reasons for not wearing wrist guards were “a lack of safety consciousness (35%), dissatisfaction with the design (25%), and the perception that wrist guards did not provide sufficient protection (19%)” [9].

### 2.2 Analysis of Wrist Fracture

Distal radius fractures frequently occur just one inch from the end of the bone and are often caused by a fall on an outstretched hand. The most common type of fracture is the Colles’ fracture, where the fragment of the broken radius points upward. This is an extra-articular, displaced fracture as shown in Figure 1; the entire end of the radius is broken off causing dorsal displacement [11].

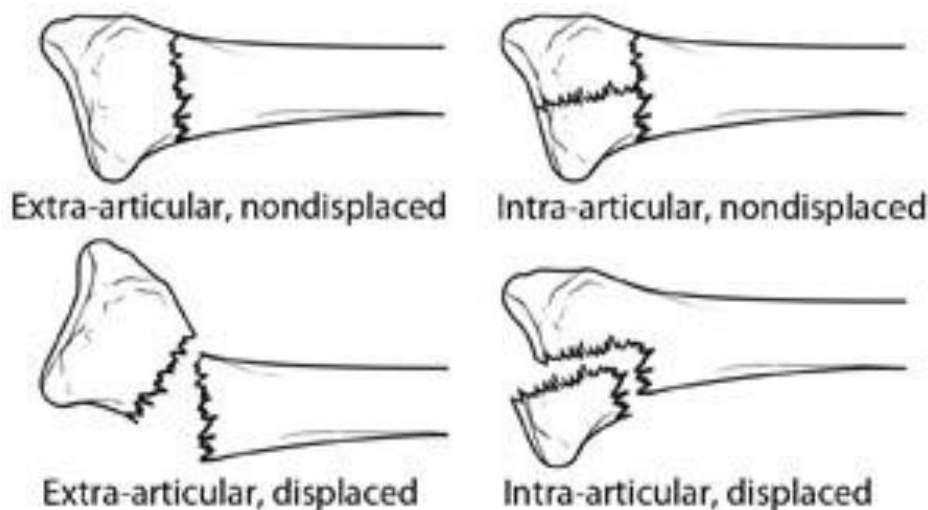

Figure 1. Distal radius fractures

The radiocarpal joint, more commonly known as the wrist, serves as the connection between the forearm and hand. The wrist is a condyloid joint, which can be described as a modified ball and socket joint. This joint allows four simple movements: flexion, extension, abduction and adduction. The

movements of the distal radius are made possible by the flexor carpi radialis, extensor carpi radialis longus and extensor carpi radialis brevis. It is important to note that the ulna is not part of the wrist joint [12].

The wrist's function is to provide the range of motion and stability necessary for performing day-to-day tasks. The condyloid joint plays a big role in the wrist's range of motion by permitting movement in the dorsopalmar and radioulnar planes simultaneously. The palmar and dorsal radiocarpal ligaments and the ulnar and radial collateral ligaments are responsible for stabilizing the wrist joint. The palmar radiocarpal ligaments are the strongest contributors in connecting the radius to the proximal and distal rows of carpal bones. During supination, this connection ensures that the hand moves with the forearm. The dorsal radiocarpal ligament has a similar function but since it is on the dorsal side of the wrist, it ensures that the hand and forearm move together during pronation [13].

Shown in Figure 2 are three forces that result during a fall. The back of the hand is pushed towards the forearm into hyperextension (first image) putting force on the distal radius bone. Furthermore, there are often two additional twisting forces from pronation and supination (third and second images respectively). These motions, known as radial abduction, contribute to a higher force on the radius. If these three forces together reach a certain magnitude, the distal radius can break [14]. During a forward fall, the ulna bone can also be at risk. If the forearm is already pronated at the moment of impact, a rotation force occurs resulting in twisting of the ulna. Because the ulna is fixed to the ulnar carpal ligament, it cannot rotate and may break [15].

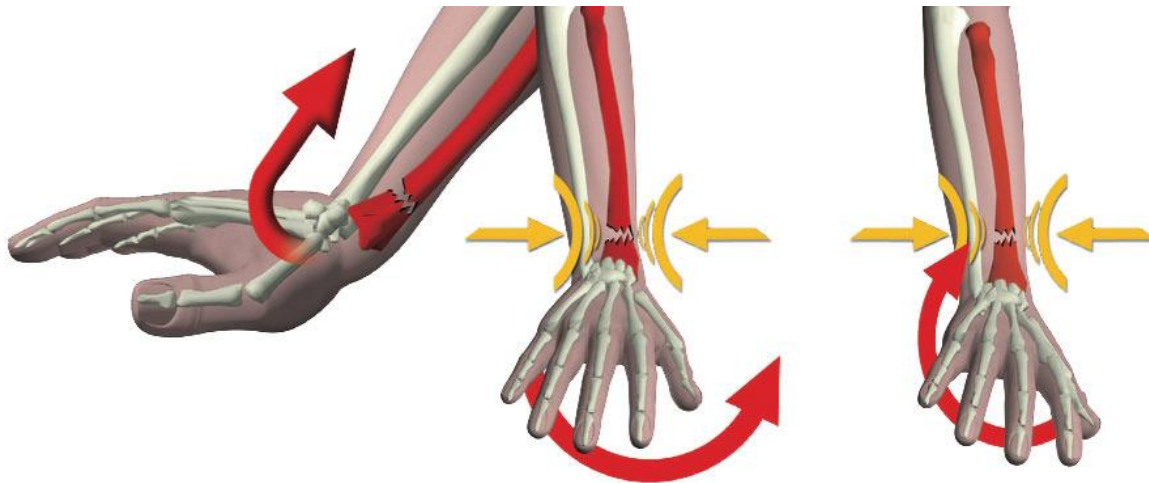

*Figure 2. Wrist fractures caused by hyperextension and radial abduction*

A small number of journal articles address this twisting of the radius leading to fracture. Many of the articles focus on axial compression as the main driver for distal radius wrist fracture. One company that manufactures a snowboarding glove with an attached wrist guard, LEVEL Snowboarding, claimed that their wrist guard addressed twisting forces due to pronation and radial abduction. Because of the company's claim, our team decided to investigate forces caused by twisting during a backwards fall.

Limited amounts of information pertinent to twisting forces during a distal radius fracture are published by peer reviewed journals. One study identified a moment of 86 N-mm during the recreation of a Colles' fracture on an excised human radius. The article results stated however, that at the metaphyseal fracture location, the compressive loading causes more than 99.99% of the maximum strain and less than

0.01% of the strain is caused by bending [16]. The previous statement coincided with our previous research on distal radius fractures, as Wagner points to axial compression being responsible for the majority of the breaking force.

## 2.3 Mechanics of Falling

The risk of injury due to falling while snowboarding is greater when compared to that of alpine skiing and other downhill winter recreations. The most common injury mechanism for snowboarders is a result of an applied compressive load on outstretched limbs in attempt to regain balance and break a fall [7]. Falls on outstretched hands are a significant cause of upper extremity injuries, accounting for approximately 90% of the fractures occurring at the distal radius, humeral neck, and supracondylar region of the elbow [17].

When snowboarding, the subject's feet are positioned parallel to one another and perpendicular to the nose of the board (seen in Figure 3 below); therefore, a subject falls either forwards towards the toe-side of the board or backwards. Contrasting mechanical parameters are associated with both forward and backward falls. The effective mass of a subject's arm, position or angle of upper body extremities, and the biomechanical loading upon impact, all play different roles when describing the severity of an injury. Nevertheless, the direction of a fall can be used as a predictive mechanism for the location and severity of the anatomic sight injured [18].



*Figure 3. Position of a snowboarder's feet*

### 2.3.1 Analysis of Forward and Backward Falls

As of 2013, there was no required minimum performance standard for snowboarding wrist protectors worldwide [19]. In response, The International Society for Skiing Safety (ISSS) convened a task force to develop a system to evaluate the importance and necessity of a minimum performance for all wrist protectors used in snowboarding [7]. To derive this minimum performance standard, researchers established the worst case scenario of snowboard falls. Field studies conducted experiments with forward and backwards falling simulations to determine the kinematics upon impact and to calculate the resulting loads within the upper extremity.

A study carried out in 2012 characterized the mechanical parameters of forward and backward falls as experienced in snowboarding. In this particular study, laboratory experiments were designed to mimic six different falling situations to measure the basic parameters describing the kinematics and biomechanical loading on the joints at impact. The experimental data suggests that the “impact forces recorded from forward falls (scenarios Forward-low and Forward- medium) were higher along with

higher drop heights compared to the corresponding backward falls. [20].” The corresponding data from the experiment can be viewed in Figure 4 below. The elbow angle at impact showed a more extended arm in backward falls compared to forward falls, whereas the wrist angle at impact remained similar in forward and backward falls. The study results suggest a new performance standard for wrist guards, indicating the following parameters in Figure 4 to characterize an impact. The specific heights, impact angles, and the respective impact force of each falling scenario can be viewed in this figure as well. The scenario in this study did not necessarily represent realistic falls as the volunteers were expecting the fall at predetermined heights. “Scenarios Backward-High and Forward-High represented the most realistic situations” and in these simulations there is no significant increase of impact force between the two falling techniques [20].

Table III. Results for a sub-sample with matched wrist heights in corresponding scenarios ( $M \pm SD$ ).

	Low			Medium			High		
	BL	FL	$p$	BM	FM	$p$	BH	FH	$p$
Impact force [N]	334 ± 149	813 ± 372	<0.001*	649 ± 186	803 ± 296	0.015*	739 ± 227	706 ± 177	–
Impact acceleration [g]	11.11 ± 4.55	33.98 ± 10.16		22.10 ± 10.41	36.60 ± 14.66		13.37 ± 2.00	18.09 ± 10.75	
Effective mass [kg]	2.78 ± 0.98	2.47 ± 0.6	0.179	3.22 ± 1.14	2.37 ± 0.79	0.006*	5.21 ± 2.28	2.95 ± 2.64	–
Elbow angle [°]	154 ± 23	149 ± 26	0.288	156 ± 11	138 ± 30	0.002*	160 ± 10	135 ± 21	<0.001*
Wrist drop height [cm]	23.4 ± 1.0	23.4 ± 1.0		13.5 ± 0.6	13.1 ± 0.7		77.2 ± 1.4	77.5 ± 1.5	0.141
Impact velocity [m/s]	1.01 ± 0.20	1.35 ± 0.24	<0.001*	1.33 ± 0.23	1.38 ± 0.30	0.260	3.12 ± 0.45	2.94 ± 0.50	
Impact angle [°]	77 ± 23	77 ± 9	0.484	74 ± 10	77 ± 7	0.073	75 ± 3	73 ± 4	0.066
Shoulder drop height [cm]	67.5 ± 3.3	76.6 ± 4.0		67.2 ± 3.8	66.9 ± 2.6		131.1 ± 2.6	129.5 ± 8.1	

Notes: Results of the student t-test analyses checking for differences between corresponding forward and backward falls are included (not for trials in which an athletic crash mat influenced the measurements). BL, FL, BM, FM, BH, and FH refer to the different test scenarios as described in the methods and Figure 1. \* Denotes a significant difference ( $p < 0.05$ ).

Figure 4. Results from a study of backward and forward falls from a low, medium, and high height [20]

A later study, published in the Procedia Engineering, carried out simulations using a multi-body system (MBS) containing a human model, a model of a ski slope and a model of a snowboard. The forward fall occurring about the toe-side and a backward fall about the heel-side of the snowboard were evaluated. An example of the MBSs are depicted in Figures 5 and 6 below. After performing simulations on the MBS, the backward fall with outstretched hands proved the worst case scenario compared to other falling situations [19]. “These results are in accordance with the experimental results published by DeGoede & Ashton-Miller (2003) which also measured peak forces with outstretched elbow joint”. A study that collected real life sample data concluded that backward falls occur more often and result in twice as many fractures as forward falls [21].

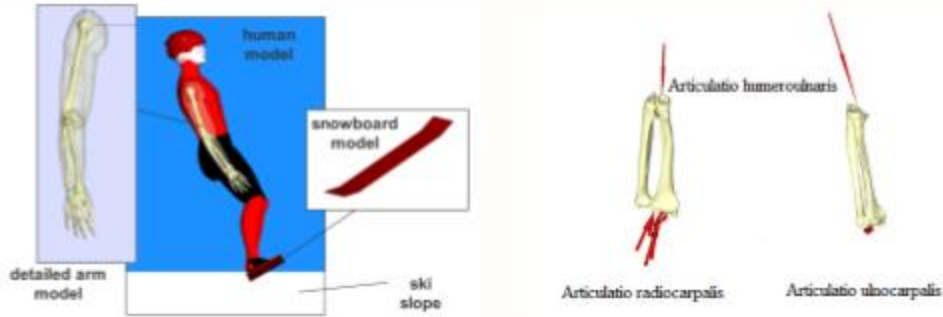

Figure 5. Left: MBS model including human model, a model of a ski slope and a model of a snowboard. Right: Predicted contact forces in the Articulatio radiocarpalis, the Articulatio ulnocarpali and the Articulatio humeroulnaris

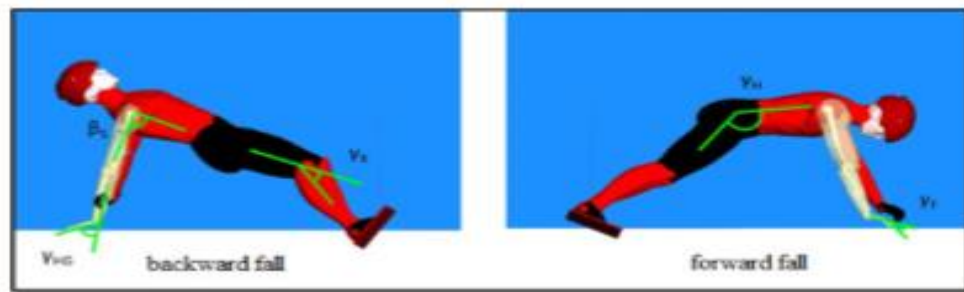

Figure 6. Predicted simulation backward fall and forward fall of the human model

### 2.3.2 Pressure Distribution over the Palm Region During Falls

Falls on the outstretched hands cause over 90% of wrist fractures, yet little is known about bone loading during this event. The study “Pressure distribution over the palm region during forward falls on outstretched hands,” was completed in order to determine the magnitude, location, and distribution of pressure over the palm region during forward falls. Through experimental data analysis, the authors defined three regions over the palm: “area A – a circle of 5 cm diameter, centered at the scaphoid, area B – an adjacent 2 cm wide donut shape and area C – the remainder of the palm region” [22]. An image of these three regions is displayed in Figure 7 below. The three areas in the study were distinguished due to the likelihood of an applied force being transferred to the radius. Area A, the ‘danger zone’, covers a 2.5cm radius around the scaphoid. This bone articulates with and transmits force to the distal radius. Therefore, a peak force located within the danger zone would cause the largest force transmission to the radius bone. Displayed in Figure 8 are the force distributions across each area [2]. The padding used in this experiment was a 5 mm thick foam which was not an effective material for total impact absorption. It caused substantial reduction in peak pressure but had little effect on peak total force. On average, the pad reduced peak pressure by 83%, and peak force to the “danger zone” centered at the scaphoid by 13% [22].

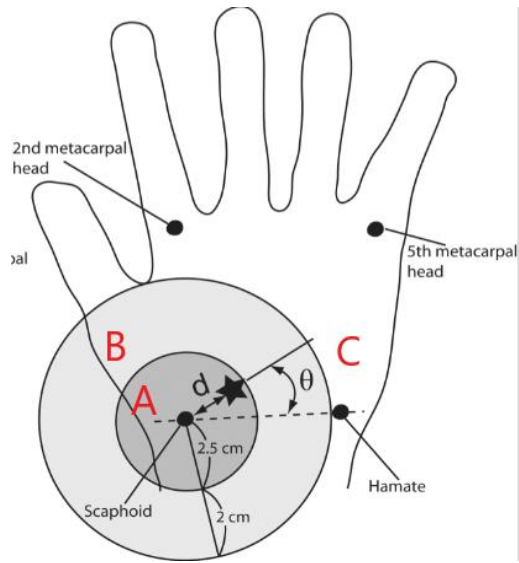

Figure 7. Three danger zones across the palm [22]

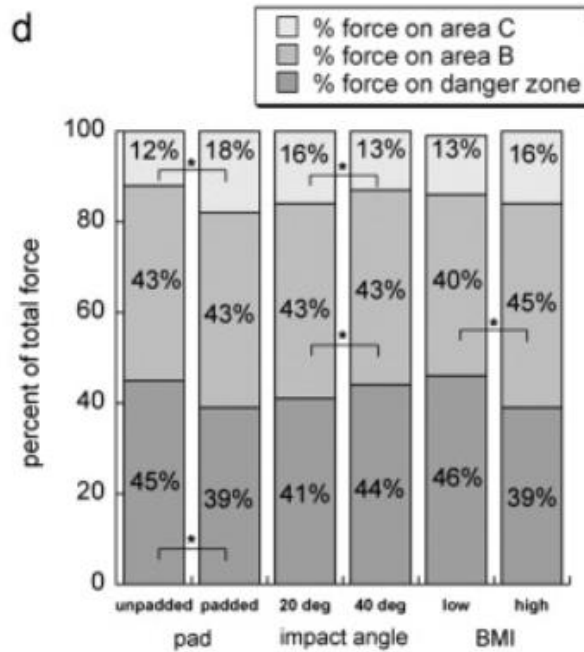

Figure 8. Force distributions for each danger zone with respect to padding, impact angle and BMI of the subject [22]

## 2.4 Current Protection

The primary goal of a wrist guard is to provide efficient protection and force absorption to prevent injury of the wrist [23]. Some wrist guards limit the movement where others are designed for

more flexibility. Additionally, wrist guards come in different forms such as protective gloves, wrist braces, or wrist guards shown in Figure 9.



*Figure 9. Different types of wrist protection*

The protective gloves above have a wrist guard built in the interior of the glove. These eliminate the struggle to fit gloves over bulky wrist braces or guards; however, the glove is designed to disperse force from the wrist to the forearm, potentially producing an adverse effect [8, 24]. Wrist braces generally offer more support and protection. They are used more frequently by snowboarders who have had a previous wrist injury or are still in recovery. Wrist guards are usually slim enough to fit into a snowboarding glove and more budget friendly. There are two main types of conventional wrist guards: one which aims to protect the palm, and the other that functions by supporting the back of the hand. The palm design cushions the hand during a fall and includes a splint that limits side to side movement. Dorsal support wrist guards contain a brace in the back of the hand to prevent backward and sideways bending. For further protection, a wrist guard could include both the palmar and dorsal components [24]. Examples of wrist guards can be found in Appendix I.

## 2.5 Studies on Wrist Guards

To assess the effectiveness of wearing wrist guards, researchers performed experimental studies and evaluated numerous injury reports. Wrist guards were found to successfully reduce the risk of wrist injuries, but no optimal design has been reported [25]. The following table, Table 1, presents information on five studies. The first two studies in the table used commercially available wrist guards, while the remaining three used custom designed guards.



Table 1. Studies on the effectiveness of commercial wrist guards and new prototypes

Source	Location	Wrist Guard	Number of Participants	Result
Ronning et al., 2001 [26]	Norway	Smith & Nephew D-ring wrist brace	5029 (2515 protected)	1.2% without a wrist guard broke their wrist compared to only 0.3% of protected individuals
O'Neill et al., 2003 [27]	USA	Wrist guard from Seneca Sports Inc.	2355 (551 protected)	2.2% of the control group injured their wrists compared to 0% of those wearing the wrist guard
Machold et al., 2002 [28]	Austria	optimized wrist guard prototype	721 (342 protected)	0.29% in the protected group injured their wrist compared to 2.3% of unprotected snowboarders
Maurel et al., 2013 [29]	UK	Compared an Anarky wrist guard to 3 different padding mechanisms on only the impact area	n/a	The new guards reduced impact forces as much as the existing wrist guards even with the reduced impact surface area (48% reduction)
Kim, 2006 [30]	USA	examined different padding mechanisms for wrist guards	n/a	Compared to a bare hand, a wrist guard reduces impact by over 30%

These studies demonstrate the effectiveness of wrist guards but do not show one to be better than the others. The drawback of commercially available wrist guards is that they greatly restrict movement and are not likely to be worn as they are uncomfortable and bulky [31]. Researchers have now suggested creating wrist guards that are aesthetically pleasing and more comfortable and are working towards finding an optimized design [28]. Additionally, there is debate as to whether wearing wrist guards produce an adverse effect for the forearm and shoulders. A few studies have claimed wrist guards do not absorb force, but rather transfer the impact force away from the wrist and onto the forearm and shoulders resulting in injury [8, 32]. On the contrary, other studies provide evidence against this argument [27, 29, 33]. More research needs to be done to test the effectiveness of conventional wrist guards.

## 2.6 Potential Materials for Improvement to Impact Force Absorption and Dispersion

Researchers have provided possible improvements and next steps for designing and testing wrist guards. Currently, wrist guards are bulky and should be adapted so more snowboarders are willing to wear them. There are opportunities to improve the materials used to create a hard-outer shell that is as thin and light as possible without compromising the effectiveness [34]. The padding used for impact resistance should reduce peak pressures significantly by absorbing the impact force from a fall without increasing total thickness to an uncomfortable point [29].

### 2.6.1 Shear Thickening Fluids

Shear thickening fluid (STF) is a dilatant material that has been involved in many new engineering designs related to impact absorption. STF is a non-Newtonian fluid whose viscosity increases dramatically when the shear strain rate exceeds a critical value [35]. Shear thickening fluids have fluid-like properties when little or no shear force is applied. Once the liquid experiences an applied force, STF turns into a rigid solid-like material that is capable of absorbing large impacts. When the impact force dissipates and is no longer acting on the material, STF again mimics the properties of a fluid.

Shear thickening fluids are desirable in various applications because the material remains flexible at rest. The fluidity of the material minimizes user discomfort in addition to offering superior impact protection. These characteristics have inspired engineers to use STF materials in the development of many different absorbers, vibration controllers and safety products [36]. There are currently a number of patent applications benefiting from STFs in a variety of fields, including industrial and sport equipment, medical tools and machine mounting.

When STF materials are used in shock loading applications, where a large amount of force is absorbed in a very short time, they are blended together with various materials. Some examples of the types of materials used in combination with STF are ceramics, polymers, micro-agglomerated cork, open cell foam, and Kevlar fabric [37]. These different composites can be described as multi-phase STFs. Multi-phase STFs are primarily STF suspensions in various other matrices. The matrix material influences the rheological behavior of the fluid. Many different combinations of STF structures have been studied in the recent years [38]. Based on an extended literature review conducted for the journal *Progress in Polymer Science*, multi-phase STFs do provide enhanced shock absorption for protective applications [36].

### 2.6.2 Zoombang Protective Gear

Zoombang Products, LLC developed a unique technology to increase the absorption of force upon impact by use of a multi-phase STF. At rest, the material is a soft putty. Zoombang polymer can be molded to form virtually any shape. Upon impact, the material stiffens into a solid state, providing up to 80% impact force absorption according to company claims. Zoombang is used in many different products over a variety of fields such as athletics, military/ tactical, industrial, and medical. Zoombang technology dissipates more force than foams and gels and it is about 40% lighter than those respective materials on average. [39]. Experimental results of the Zoombang polymer when compared to other impact absorbing materials on the market can be seen in Figure 10 below.

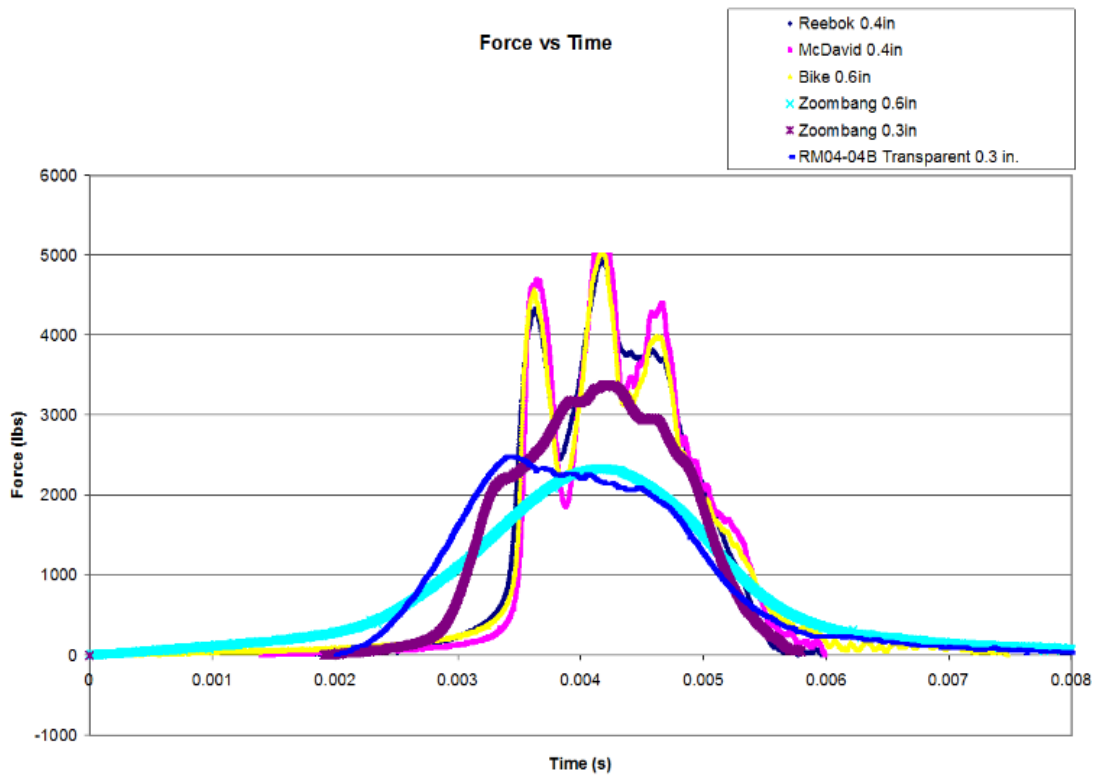

*Figure 10. Force versus time graph of Zoombang padding in comparison with other commercially available sports padding [39]*

As seen in Figure 10 above, 0.3in (7.6mm) of RM04-04B Transparent is almost equally as effective as 0.6in (15.2mm) of Zoombang. RM04-04B Transparent material is a Research and Development material currently being tested by Zoombang. The technology is an improvement of the traditional Zoombang product. The material is the result of the manipulation of the rheological properties of a polymer [39]. The graph shows that Zoombang withstands around 2,250 pound-force (10,000N) at its peak, which is about four times the amount of force required to cause a distal radius fracture.

## Chapter 3: Design Process

### 3.1 Design Goals and Criteria

Our initial brainstorming focused on addressing the major problems of current wrist guards:

1. Wrist guards are bulky and uncomfortable resulting in infrequent use by snowboarders. To increase the usage of the wrist guards, the overall thickness should be decreased, and the design should be more flexible.
2. Current wrist guards often use a hard-plastic bump in the design. Upon impact, this bump transfers the impact force to forearm, elbows, and shoulders rather than absorbing the impact force. This potential adverse effect is present in other wrist guard designs as well.

We created design goals to develop a wrist guard that is both thinner than those currently on the market and improves the force absorption capabilities. Additionally, we created a list of different criteria essential for an improved wrist guard design. The two most important criteria that match our design goals are comfort and effectiveness. With this, we developed a list of design specifications to guide our design process and define what our improved wrist guard should accomplish. We used these design specifications and furthermore considered flexibility, shape, manufacturability, and durability to evaluate our preliminary designs.

1. The wrist guard must not be thicker a conventional wrist guard's thickness at around 19mm.
2. The wrist guard must not weigh more than 8oz.
3. The wrist guard must withstand a force of 3,000 lbf (13,344 N) without breaking during an impact test.
4. The wrist guard must not permanently deform after 5 consecutive impact tests.
5. The wrist guard must last longer without breaking during an impact test when compared to a conventional guard.
6. The wrist guard must fit on the palm of the hand and must cover the danger zone of the hand.
7. The wrist guard should allow bending of the wrist in all directions and for the fingers to bend towards the wrist.
8. The wrist guard should cost less than comparable wrist guards (Dakine wrist guard glove is \$50, but if we market ours as just the liner we could sell for \$20).
9. The wrist guard should not have any sharp edges that may puncture the skin.
10. The wrist guard must fit inside a commercially available winter glove.
11. The wrist guard should be removable to allow for washing of the glove or attachment method.
12. The wrist guard must work effectively at room temperature (68+/- degrees Fahrenheit: 20+/-2 degrees Celsius) and cold temperature (14+/-2 degrees Fahrenheit: -10+/-2 degrees Celsius).

There is a standard for "Protective clothing for use in snowboarding-- Wrist protectors-- Requirements and Methods" published by the ISO, International Organization for Standardization [40]. The standard lists many requirements for ergonomics, innocuousness, restraint, impact protection of the palm and limitation of wrist extension. However, according to our research, limitation of wrist extension does not prevent a break, rather a high impact absorption is more effective in preventing distal radius fractures from falls. We decided to create a device apart from this standard for more flexibility for the user, which we predicted would increase wearability.

### 3.2 Preliminary Design

At the beginning of our project, we listed different materials we potentially could use in our design including springs, shear thickening fluid, open and close-celled foams, air-cells, and individual cell technology. We researched each technology to determine how to effectively incorporate them into our design and to identify equations relevant to our application. We continuously brainstormed design ideas and eventually came up with five unique designs that we evaluated for viability. The designs differed based on the technology used for force absorption. The method of attachment was brainstormed independently later in the design process. Below is a description and list of materials that were incorporated in each design:

#### Design 1: Improved Bump

- Revamped commercially available wrist guards by removing the hard plastic bump and placing springs underneath the bump for further force absorption capabilities

#### Design 2: Individual Cell Spring

- Used small springs in individual cell pockets to absorb and disperse impact force. Individual pockets allowed the cells to expand outward as the spring compressed downward.

#### Design 3: Shear Thickening Fluid

- Used shear-thickening fluid impregnated foam with 50-50 ratio of foam and liquid. Encased in a durable polymer or rubber material.

#### Design 4: Leaf Spring

- Used a one leaf spring that was bent around the curvature of the wrist and placed on a track. Upon impact, the spring would straighten along the track and cause the wrist to also straighten

#### Design 5: Air Cell Technology

- A damped pneumatic spring system which included three airbags that compressed upon impact to absorb the force from impact

With each design, we evaluated the pros and cons and used a design matrix to compare each technology to one another. Shown below in Table 2, we crafted the matrix using the most important parameters for our design. We compared each of the designs against the parameter and ranked them with five being the best score and one being the worst score.

*Table 2. Design matrix for five preliminary designs*

	Design 1	Design 2	Design 3	Design 4	Design 5
Cost	5	3	1	4	2
Thickness	2	3	4	5	1

Size (most protective)	2	3	5	1	4
Impact Force Absorption	1	3	5	2	4
Durability	3	4	5	2	1
Flexibility	1	5	4	2	3
Breathability	1	1	1	1	1
Weight	3	2	1	4	5
Adjustable	1	1	1	1	1
Reusability	1	4	5	3	2
Average	2.2	2.8	3.1	2.5	2.4

For cost, we evaluated the materials that would be used in each design. Out of each design, Design 3 incorporated shear thickening fluid which would be the most costly giving it the lowest ranking of 1. The improved bump would only include plastic and a few springs estimating the lowest cost compared to the other designs. Moving onto thickness, we decided incorporating airbags would increase the overall thickness more than the rest. Furthermore, the improved bump design would have similar features as commercially available wrist guards. With a design specification to improve upon this thickness, we ranked this design second to last. The leaf spring design as leaf springs are relatively flat would create the thinnest glove closely followed by the shear-thickening material as the absorption capabilities require less thickness. For impact force absorption, with a design specification to match or improve conventional wrist guard capabilities, we gave the improved bump the lowest score of 1 as it would be expected to transfer impact force rather than absorbing it. Upon research of each material, shear thickening materials have the highest absorption potential followed by airbags and then springs.

Furthermore, the improved bump design lacked flexibility and reusability as the hard plastic component would restrict movement and upon very hard impact could break. The individual cell technology design fell middle of the pack for most criteria but ranked highest for flexibility as the gaps in between could allow the hand to bend in different directions. The shear-thickening material design would create the best protection for a device without compromising thickness, but could result in a heavier, more costly device, and more sweating of the hand. The leaf spring design was thin and cost efficient, but ultimately we couldn't find a viable way to manufacture the design. Lastly, air-bags proved effective in other case studies, but lacked a thin and reusable solution.

Each of our designs had unique properties that helped us differentiate between the choices and decide which would be most appropriate for a wrist guard application. Based upon the results of the design matrix, we decided that shear-thickening fluid and springs had the greatest potential for an improved wrist guard. We then further listed pros and cons for each design shown in Table 3 below.

Table 3. Pros and cons of each design

Design	Pros	Cons
Design 1: Improved Bump	<ul style="list-style-type: none"> <li>● Bump shown to reduce risk of wrist injuries</li> <li>● cheap</li> </ul>	<ul style="list-style-type: none"> <li>● May increase forearm injuries</li> <li>● Less unique design</li> <li>● Not flexible</li> <li>● How to attach springs to the bump</li> </ul>
Design 2: Individual Springs	<ul style="list-style-type: none"> <li>● Unique</li> <li>● Springs have good absorption properties</li> <li>● Flexibility during impact</li> </ul>	<ul style="list-style-type: none"> <li>● How will the springs bend upon impact?</li> <li>● How to ensure there is no puncture of the skin</li> </ul>
Design 3: Shear-thickening	<ul style="list-style-type: none"> <li>● High absorption capabilities</li> <li>● Unique</li> <li>● Flexible</li> </ul>	<ul style="list-style-type: none"> <li>● Hard to manufacture</li> <li>● Expensive</li> </ul>
Design 4: Leaf-spring	<ul style="list-style-type: none"> <li>● Thin</li> </ul>	<ul style="list-style-type: none"> <li>● Hard to have more than one</li> <li>● Bend around the wrist might compromise flexibility or comfort</li> </ul>
Design 5: Air cells	<ul style="list-style-type: none"> <li>● Light-weight</li> <li>● Good absorption capabilities</li> </ul>	<ul style="list-style-type: none"> <li>● Complicated to re-inflate</li> <li>● Thicker than the other designs</li> </ul>

After further investigation and evaluation of each design, we decided to combine multiple technologies to create a hybrid of our preliminary design. The design incorporated individual cell technology with shear thickening fluid, springs, and foam. We decided against using air-cells due to the problem of re-inflating the airbags to make the device reusable. Additionally, we chose to include helical springs over leaf springs in our preliminary design as the leaf springs may not have been as flexible as the helical springs. A hand drawing with a sketch of our initial design is shown in Figure 11 below:

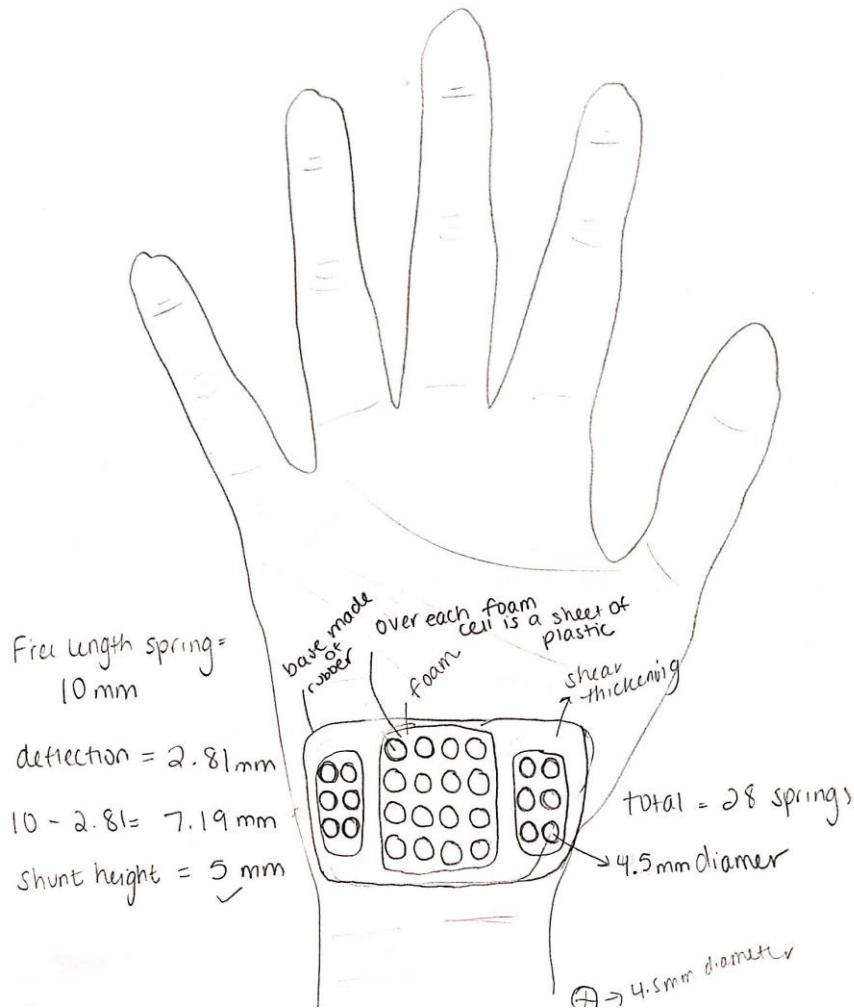

Figure 11. Preliminary design sketch

After settling on our design, we created a MATLAB file to determine the optimal number and dimensions of the springs. We chose the shut height and free length dimensions to ensure our design met criteria one described in the figure above and calculated the remaining parameters to find a viable spring solution. We based the other dimensions for the foam, plastic, and shear thickening portions on the dimensions of the springs by visualizing the placement of the springs and modeled the design in SolidWorks.

The preliminary design is pictured in Figure 12 below. This design was 66mm (2.60in) in length and 33mm (1.30in) in width, with the overall thickness of 14mm (0.55in). The design's thickness was an improvement upon the 19mm (0.75in) of other wrist guards on the market. Based upon our preliminary spring calculations, we believed our design would reduce impact on the radius bone, successfully preventing injury. The design incorporated two different impact absorption materials; metal springs surrounded by a shear-thickening foam composite. The 2-D SolidWorks drawings for the final assembly can be viewed in Appendix II.



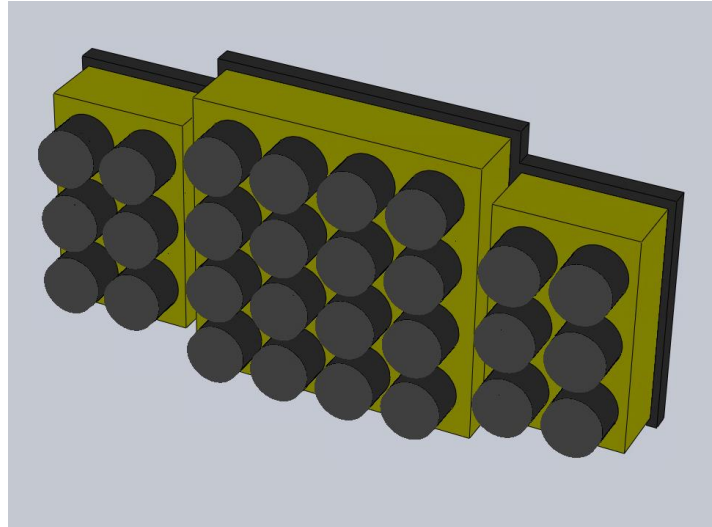

Figure 12. Preliminary design

To use springs with a small enough deflection for a slim wrist protector, the diameter of the springs had to be very small. With the small sized springs, the wrist guard could remain comfortable and not too bulky. We originally decided on the parameters of our desired spring, listed below in our MATLAB file in Figure 13. We chose the wire diameter and number of springs to give us a reasonable shut height of 5mm (0.20in). From these inputs, we solved for deflection of the spring, shown in Figure 14. The deflection needed to be above the shut height and below the free length of the springs in order to prevent bottoming out. The deflection also depended on the number of springs needed to absorb enough force to reduce the force of impact below the 2,245N (505 lbf) force threshold which results in distal radius fracture. We altered our inputs in order to obtain a reasonable deflection based upon the design restrictions we identified.

```

Editor - R:\springs.m
springs.m  X  +
1 - density = 7860 ; %kg/m^3
2 - springindex = 5 ;
3 - G = 79289.70872000001 ; %Mpa or N/mm^2
4 - WireDiameter = 0.9 ; %mm
5 - SpringDiameter = 4.5 ; %mm
6 - ShuntHeight = 5 ; %mm
7 - TotalCoils = ShuntHeight * WireDiameter ; %mm
8 - ActiveCoils = TotalCoils - 2 ;
9 - FreeLength = 10 ; %mm
10 - NumberSprings = 28 ;
11 - Pitch = (FreeLength-2*WireDiameter)/ ActiveCoils ; %mm/coil
12 - Load = 2245 / NumberSprings ; %Newtons per spring
13 - Deflection = (8*Load*ActiveCoils*(SpringDiameter^3))/(G * WireDiameter^(4))%mm
14 - SpringRate = (G * WireDiameter^(4))/(8*SpringDiameter^(3)*ActiveCoils)%n/mm
15 - Mass = (density * pi^(2)*TotalCoils*(SpringDiameter*10^-3)*((WireDiameter*10^(-3))^2))/4 %g
16

```

Figure 13. Spring parameters and equations for desired deflection based on parameters

```
Command Window
New to MATLAB? See resources for Getting Started.

Deflection =

    2.8089

SpringRate =

    28.5443

Mass =

    3.5345e-04
```

Figure 14. Solutions from above equations

By combining the springs and foam, we aimed to eliminate the potential for the springs to puncture the users skin. Foam also absorbs force during impact, so its inclusion into the design was considered beneficial overall. The spring cells were capped with thin plastic in order to protect each spring and provide a uniform distribution of stress across each cell . Shear thickening fluid impregnated foam surrounded the individual cells. The shear-thickening foam was designed to be thinner than each spring cell because the springs would have a greater deflection than the shear thickening foam. Therefore, the design would allow the springs to reach the full absorption potential before the force comes in contact with the shear-thickening foam composite.

### 3.2.1 Manufacturability of Preliminary Design

To effectively manufacture our preliminary design, we needed to combine two different impact absorption materials: mechanical springs and a shear-thickening foam composite. The individual spring technology became a problem as our team investigated the availability of our desired spring material and size. Online sources that sold springs did not provide springs that had the same pitch and other mechanical properties to obtain the required deflection. It proved difficult to find springs with our specifications made out of ASTM A231: chromium vanadium. This material was desirable for its range in wire diameter and its impact loading capabilities [41]. Although we used helical spring equations to determine the specifications of our spring, it seemed as though our desired spring specs were not reasonable for spring manufacturing. We altered the parameters of the spring in order to get a certain deflection and in theory, many combinations of the given values could produce a desirable spring deflection, but it did not mean that the combination of those parameters for a spring were available for purchase. Upon further investigation, we could not find any springs for purchase with the exact dimensions we requested. Additionally, cold temperature would also affect the effectiveness of the springs and only maximum working temperature was given for our spring material selection. Given a variety of thermal factors including changing weather and varying heat generation from the body, our team was unsure of the temperature the springs would reach in the device during snowboarding use and without a minimum working temperature listed for the material, we weren't even sure if the springs

would work properly below freezing. Lastly, unidirectional springs would theoretically work for a uniaxial load, which was improbable for a snowboarding related fall, where contact angle between the hand and the ground may vary drastically. These factors all contributed to our final decision to not incorporate springs into our impact absorption device.

Shifting the focus to the STF foam composite, the process needed to develop a shear-thickening foam composite was extremely complex. The process to develop a STF impregnated foam was derived from previous studies that conducted research on such materials, such as the study completed by Soutrenon in 2014 on the impact properties of shear thickening fluid impregnated foams. The materials necessary for this product are a STF, silicone for encapsulation, and an open celled foam [38]. In order to create a shear- thickening composite, first spherical silica particles with an average diameter of 50 nm (1.97e-7in) would be suspended in polyethylene glycol. The particle concentration of the solution would be set to 67.5% weight silica. These materials would then be mixed together and sonicated in order to achieve the uniform dispersion that results from ultrasonic preparation [42]. After, a centrifugation process was needed to ensure highly-packed concentrations. In order to develop the STF impregnated foam, a custom mold is designed to compress the foam at a defined thickness, and then a vacuum pump is used to saturate the foam with the STF. An example of this type of mold can be seen in Figure 15 [38]. The foam would need to be encapsulated with silicone in order to protect the impregnated foam from the environment.

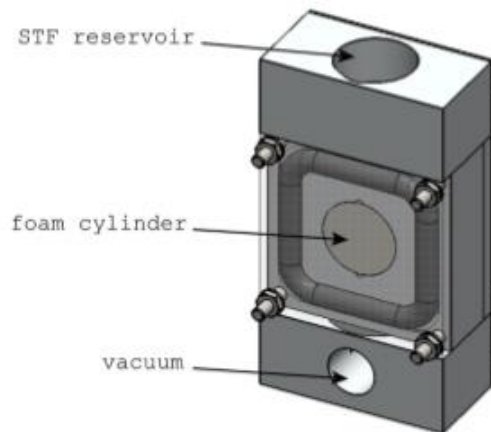

*Figure 15. Example mold for foam impregnation*

This manufacturing process left a lot of room for error to create a stable and effective product. The materials that were required would use up most of our budget for the project, with no guarantee that we would produce a working prototype. Also, the required machinery and manufacturing devices needed in this process were not available at Worcester Polytechnic Institute. As a result, we did not manufacture a shear-thickening foam composite on our own without an outside manufacturer.

## 3.3 Final Design

### 3.3.1 Impact absorption prototype design

With the inability to manufacture our own shear-thickening foam composite based on prototyping and research, our team shifted our focus to the use of a commercially available product with better-than-average impact absorption capabilities and use in force absorption applications already. We decided to reach out to Zoombang to obtain a sample of their polymer. With this sample, we planned to assess the effectiveness of this technology. We also requested technical white papers with more information on the product. Zoombang completed numerous tests comparing their padding to other commercially available sports padding. The compared materials were closed cell foams (McDavid and Bike) and air bladder (Reebok) pads. Even though their testing showed a dramatic difference in performance in favor of the Zoombang padding which produced less than half the force upon impact compared to competitors, we completed our own force tests and compared results. The results we found yielded similar results.

We decided to move forward with Zoombang's shear-thickening polymer as the company could create a custom pad for our special application with a three-day turnaround. Using information discussed in section 2.3.2, we created different designs that protected the danger zones of the hand without compromising flexibility. We used two different base shapes, one based off the team's initial thoughts (Base 1) and one based off Zoombang's sample (Base 2). Although Zoombang sent us many samples of padding for hands, the base we chose to replicate in SolidWorks was almost the exact base that we had created without previous knowledge of Zoombang's design. We created ten different configurations of Zoombang pockets for Base 1 and eleven for Base 2. The individual cells covered the areas most at risk and followed the natural curvature of the hand to allow the hand unrestricted movement. The design shown below in Figure 16 is an example of one of the designs we created on Base 1 and the design in Figure 17 shows an example design for Base 2. Each individual cell would be filled with Zoombang's shear thickening polymer.

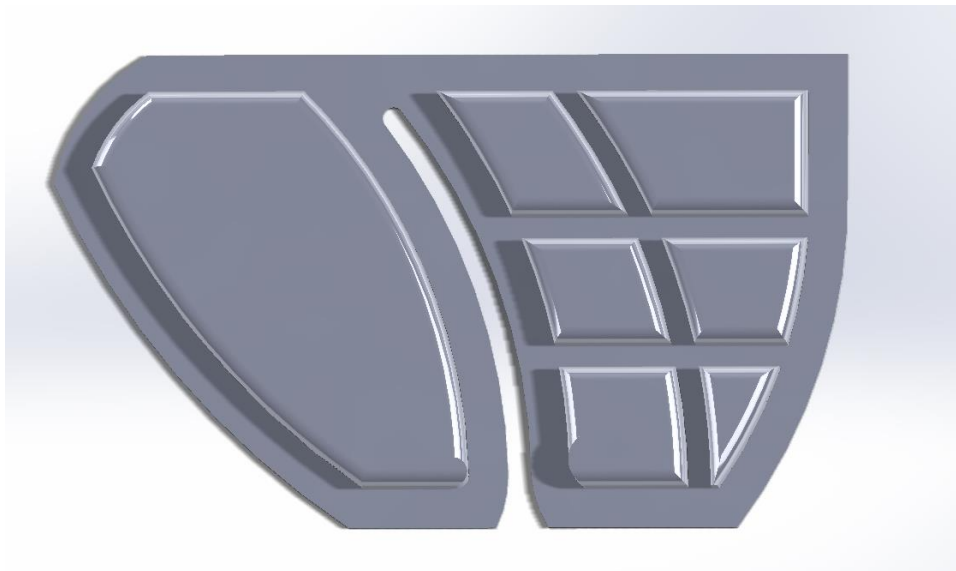

*Figure 16. Example design of Base 1*

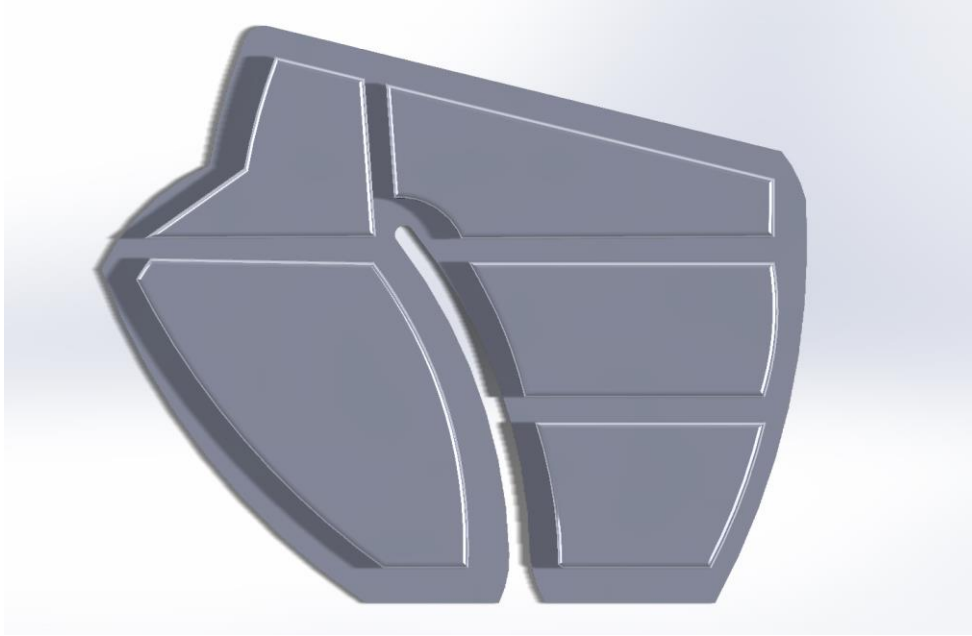

*Figure 17. Example design of Base 2*

### 3.3.2 ANSYS Force Testing

We tested the different wrist device variations in ANSYS to evaluate which design would be the most effective. By evaluating the results of a dynamic loading test, we determined which base and configuration had the most optimal stress distribution and values. We imported our designs into ANSYS to perform software tests to mimic the distribution of forces during a fall. We used consistent properties throughout the trials. Since we only wanted to find the optimal shape configuration, we used the default material of structural steel. This material is the default for ANSYS transient structural dynamic load testing. It was the simplest for conducting ANSYS analysis and was recommended for use by Professor Adriana Hera. We used an initial velocity of 8 m/s as this is on the high end of speed for beginner snowboarders prior to falling. We then tested in ANSYS until we found the best mesh size and initial conditions. Because of consistency in our designs and tests, we effectively compared the shapes of each design. Comparing the pad configurations was the main purpose of our ANSYS testing as we could not simulate Zoombang's proprietary shear thickening polymer without knowing the specific material properties which have not been published.

The purpose of recreating Zoombang's base design, base two, was to compare it to our unique base design in ANSYS. We created variations of pad configurations on base two, but the most important data collected was from design 10 as it was a recreation of the pad configuration from the Zoombang sample that we received. Figure 18 represents the stress seen on design 10. The maximum stresses ranged from 1,101,900 to 1,165,300 Pascals (160 to 169 psi).

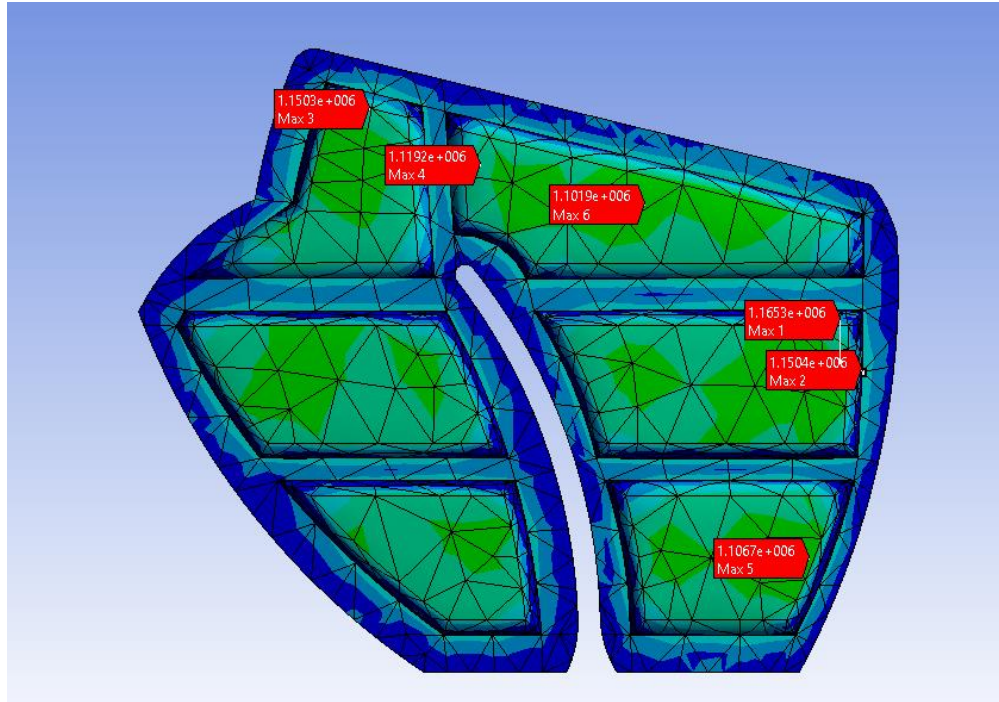

Figure 18. Stress on Base 2 Design 10 of ANSYS simulation

We concentrated our efforts on Base 1 as it covered the danger zones of the hand while not covering unnecessary areas that would not result in radius fractures. We initially compared the first nine designs based on stress. ANSYS automatically gave the highest six stresses. Table X below shows the most effective to least effective design from left to right:

Table 4. Top 6 maximum stresses for each design of Base 1 (measured in Pascals)

	Design 9	Design 4	Design 7	Design 3	Design 5	Design 8	Design 6	Design 2	Design 1
	1374300	1412600	1701000	1960500	1992900	1983700	2204200	2928100	3541600
	1258200	1401100	1311100	1409000	1595000	1941300	1912000	2043400	2140500
	1021400	1077800	1281100	1409000	1396300	1479200	1520600	1409400	1651400
	1010600	1069800	1270900	1397800	1343000	1463800	1465700	1386900	1624700
	978670	1063900	1226700	1378300	1288500	1461600	1462300	1364400	1606500
	973800	1037000	1202100	1319400	1273700	1443500	1442700	1306100	1597900
avg	1102828	1177033	1332150	1479000	1481566	1628850	1667916	1739716	2027100

For each design, the sharper corners and edges that were not filleted led to higher stress points. We adapted our design slightly in the two top performing pad configurations (design 4 and 9) in an attempt to relieve these. We also decided to create a new pad configuration that breaks up the right pad into two (design 10). We expected this pad to produce stress values in between design 4 and 9 with the hypothesis that greater surface area leads to better stress profiles. We adapted and reran the simulation for

the top two designs (design 9 and design 4), and for a new design configuration (design 10). Below are the ANSYS results in Figures 19, 20 and 21.

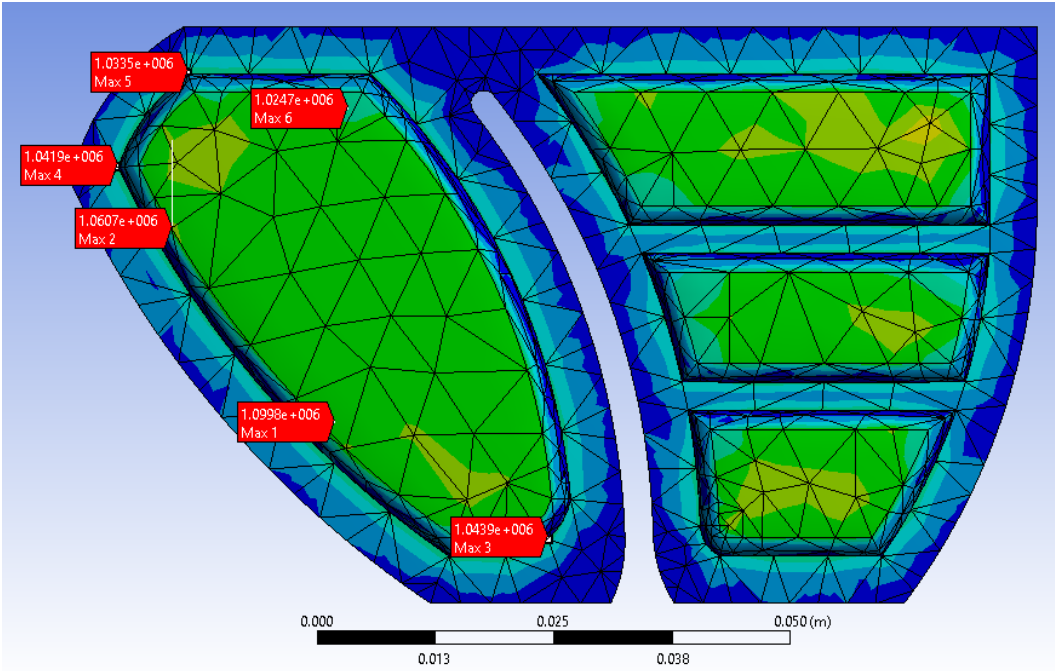

Figure 19. Stress distribution of Base 1 design 4 of ANSYS simulation

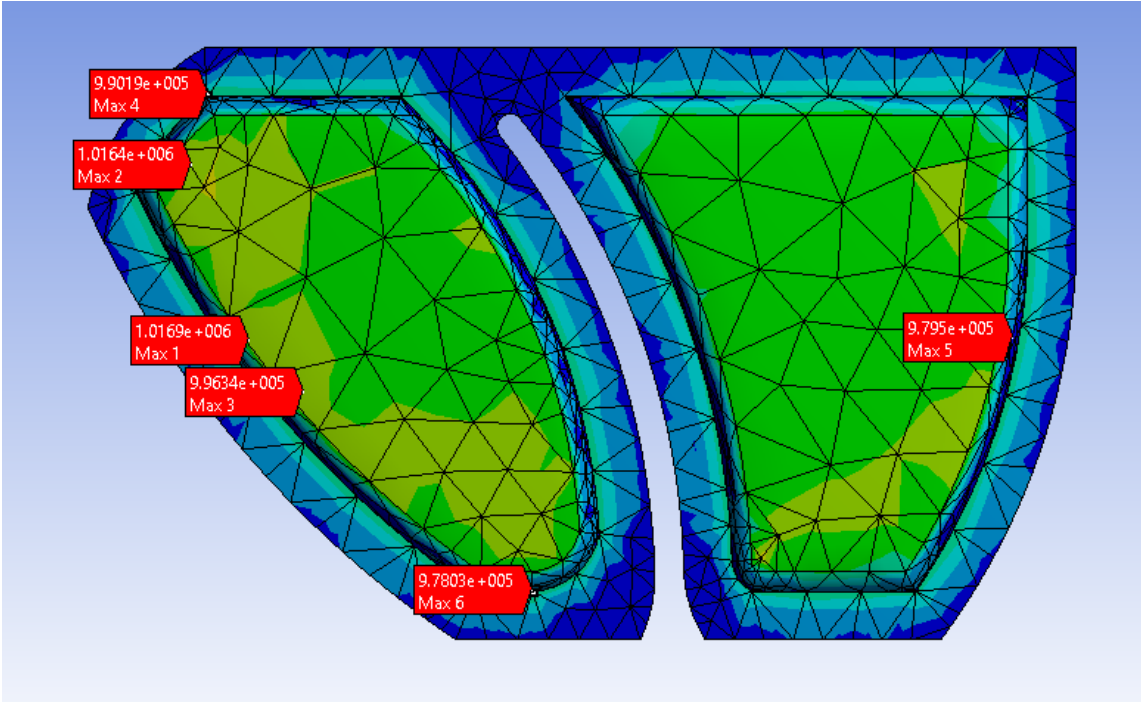

Figure 20. Stress distribution of Base 1 design 9 of ANSYS simulation

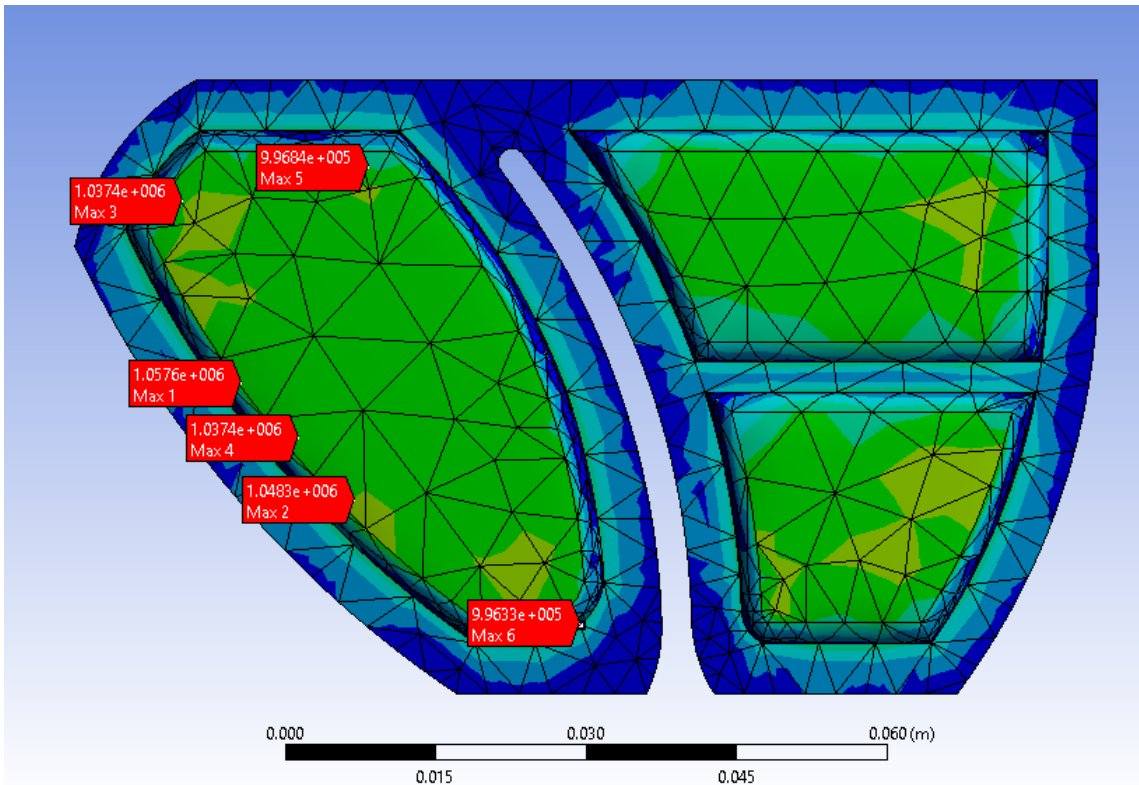

Figure 21. Stress of Base 1 design 10 of ANSYS simulation

Below are the results, in Table X, of the maximum stresses in Pascals.

Table 5. Maximum stresses for design 4, 9, and 10

Design 4	Design 9	Design 10
1024700	978030	996330
1033500	979500	996840
1041900	990190	1037400
1043900	996340	1037400
1060700	1016400	1048300
1099800	1016900	1057600

With this information, it was evident there were lower stresses with higher surface areas as design 9 performed best. Furthermore, the stresses occurred at the edges of the padding but the danger zones of the hand were completely covered and produced lower stresses. Before solidifying design 9 with Base 1 as our final design, we tested the Zoombang material to see if flexibility was an issue. Prior to impact, the polymer formed to the hand. Upon impact, the polymer stiffened and absorbed the force, but it kept its form to the curve of a hand. At the end of the test, flexibility was not a concern with the final design. To finalize the design, we needed to determine the thickness. The thicker the pad, the more effective



absorption occurred; however, it was imperative the design was not too thick so that it was uncomfortable or could not fit inside a snowboarding glove. To balance thickness and corresponding impact absorption with comfort, we chose a thickness of 15mm (0.59in). This thickness met are design criteria goal of less than 19mm (0.75in). With this information, we ranked the designs based on which would provide sufficient flexibility. Below, in Figure 22, was our final design in which we sent to Zoombang for approval.

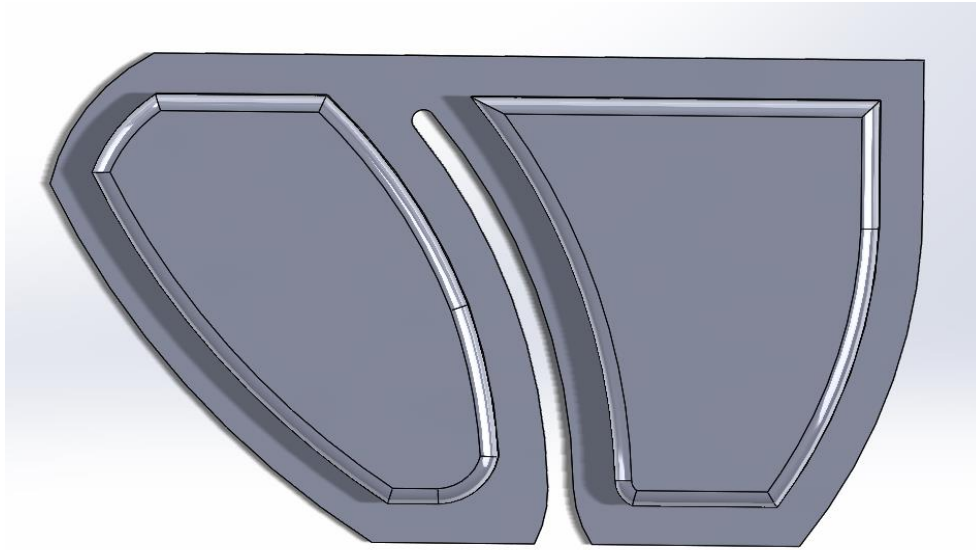

*Figure 22. Final design*

### 3.3.3 Manufacturing, Encapsulation, and Attachment Methods

Upon waiting four weeks for Zoombang to respond and create our custom pad design, we decided to take matters into our own hands and manufacture the wrist device ourselves. We decided to research materials that could form an encapsulation around the Zoombang polymer. Zoombang's encapsulation is made of Polyurethane but we also considered Polyethylene and Nitrile.

Given our time constraints, we were unable to find Polyurethane in the form that we wanted for encapsulation. We also ruled out many material processes including injection molding and casting after having a conversation with Professor Shivkumar of WPI. He explained how it would be difficult and maybe not even possible to find a facility to conduct the manufacturing processes we desired to create our prototype. Polyethylene, specifically LDPE, was available in sheets and could be used to form molds by heat treatment. The material had good impact, abrasion, and corrosion resistance, and a working temperature range of zero to 140 degrees Fahrenheit [43]. Although snowboarders may experience outside temperatures colder than zero degrees, the body heat from the hand, and extra insulation from the glove was expected to keep the prototype at a high enough temperature. Polyethylene additionally is soft, flexible, and often used in orthotics and prosthetics [44]. Since the Zoombang polymer material properties are unknown, we decided to wrap the polymer in a Nitrile film before encapsulating in Polyethylene. Nitrile gloves are inexpensive and readily available. They are also used for medical purposes and sometimes classified as medical grade, so we decided that this material would not have a negative reaction when in contact with the Zoombang polymer [45].

The encapsulation of the Zoombang polymer with Polyethylene seemed successful upon completion of multiple pads. They had smooth seams, held their shape, and did not feel uncomfortable when in contact with the hand. After impact testing on some of the pads, we found that the Polyethylene layer was thin and extra air in the pocket caused the entire encapsulation to burst through the seams, seen in Figure 23.



*Figure 23. Polyethylene-encapsulated pad that burst after impact testing*

Since the Polyethylene encapsulation failed, we decided to use a polyester-nylon blend material for our prototype to encapsulate the Zoombang polymer. The polymer was still initially wrapped in the Nitrile material and glued shut with cyanoacrylate, which was not in direct contact with the polymer. The polyester blend was the fabric which commercially available Zoombang padding was sewn onto for sports protection use. It is flexible, breathable, and exhibits shape retention when sewed tight enough. Figure 24 demonstrates the capabilities of the polyester blend. This encapsulation method was not only more effective in expanding for the polymer's needs during impact force absorption, but also was more comfortable when in contact with the hand.



*Figure 24. Custom pad encapsulation*

After designing our prototype, the next major question to address was how to attach this prototype to a snowboarder. Traditional wrist guards are bulky but effectively use straps to attach and stay in place. We brainstormed numerous ideas including skin adhesives, VELCRO or sewing onto a glove and ultimately decided to sew the impact absorption device onto a snowboarding glove liner to make an all-in-one protection device for the market. The pockets for holding the Zoombang custom pads were constructed with the same polyester blend used for encapsulating the pads. Figure 25 shows the pads inside of their respective pockets on a snowboarding glove liner.



*Figure 25. Custom pads in pockets of Men's large Burton Gore-tex glove liner*

## Chapter 4: Testing Procedure and Results

Zoombang completed numerous tests to assess the effectiveness of the technology. The test, aforementioned in section 2.6.2, compared Zoombang's padding to other commercially available sports padding. The compared materials were closed cell foams (McDavid and Bike) and air bladder pads (Reebok) [39]. To further assess the technology against our design specifications, we completed force and flexibility tests. To assess the effectiveness of the Zoombang technology specifically for our product, we created our own testing procedure based on Zoombang's testing and the ISO standard for protective clothing for use in snowboarding. We conducted a comparison and temperature impact tests as well as a flexibility test. Discussed in this section are the procedures developed and results.

### 4.1 Instron Dynatup 8250 Set-up

We conducted our impact tests using the Instron Dynatup 8250 drop impact tester machine in the Kaven Hall Civil Engineering Laboratory of Worcester Polytechnic Institute, shown in Figure 26. The machine can produce up to 50,000 pound-force (220,000 Newtons). The Instron impact tester consisted of a load cell with a 89mm (3.5in) diameter striker attached to a variable mass component. The load cell and weight could be adjusted to a variety of starting heights. The load cell and mass free fell onto the test material, and a force versus time graph was produced.

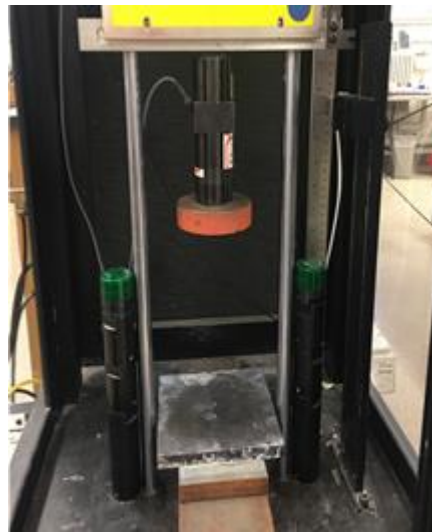

*Figure 26. Instron Dynatup 8250 Impact Tester*

### 4.2 Standardization of Testing

One challenge to completing the impact testing was the inability to test the Instron machine's force production without a material or object under the load cell. Dry test runs were not allowed because of damage that metal on metal contact may cause to the machine itself. To standardize our testing, we needed to implement a control to allow for the calculation of percent absorption. With a control, we could test the force of impact of the control and compare it to the force of impact produced with our prototype present.

Our experimental testing included testing multiple, comparable materials directly on the plate of the impact machine to act as the control. The initial testing included 12.7mm (0.5in) and 38mm (1.50in) thick cross-linked polyethylene foams. Zoombang technology works by hardening upon impact due to an increase in viscosity. The foams slowed the time of impact limiting the force and negatively affecting the absorption rate of the Zoombang design by preventing activation of shear thickening properties. The testing proved both of the foams to be too soft for use as control, and consequently, we replaced these with a flat and arched rubber block. When testing the Dakine wrist guard and our prototype to compare the effectiveness, we chose to use the arched rubber block so that the wrist guard fit as it would when an individual was wearing the device and so that we could compare our prototype to the wrist guard. To calculate percent absorption, we divided the difference between the control force and test forces of each material by the control force and then multiplied by 100 percent.

In order to best replicate snowboarding falls onto outstretched arms, we planned to conduct tests in accordance to the guidelines set by Kai-Uwe Schmitt. Schmitt's research recommended "the following parameters to characterize an impact: an effective mass acting on one wrist of 3–5 kg, an impact angle of 75° of the forearm relative to the ground, and an impact velocity of 3 m/s [20] ." To best replicate the pressure distribution over the pad, the load cell diameter gave an area that roughly matches the dimensions of the palmar region that would come into contact with the ground.

### 4.3 Force Estimation

Using kinematics equations and Newton's second law of motion, we approximated the forces that would be produced during a snowboarding fall to ensure our testing apparatus was an accurate replication. Two kinematics equations were used to obtain the test height of 0.46 meters (2.82ft) which produced a vertical final velocity prior to impact equal to 3 m/s (6.7mph). The equations used for the calculations are as follows:

$$v_f^2 = v_i^2 + 2ad$$

$$deceleration = v_f / t$$

$$F = m * deceleration$$

$v_f$  = final velocity,  $v_i$  = initial velocity,  $a$  = gravity,  $d$  = height of fall,  $m$  = effective mass,  $t$  = deceleration time,  $F$  = force upon impact

To calculate the force produced by the Instron Dynatup apparatus, we estimated the deceleration time of the impact without any padding present. To do so, we interpreted results from a similarly conducted impact test on the Zoombang material and obtained an estimated deceleration time of 0.004 seconds. The force estimate allowed for our team to compare the resulting force from a test with padding to the calculated force to best simulate a snowboarding fall.

Based on the guidelines for replicating a snowboarding fall set by Schmitt, the impact test would produce a predicted force of 3,750N (843 lbf)[20]. According to multiple pieces of literature, the force required to produce a distal radius fracture is about 2,245N (505 lbf), which is 1,500N (337 lbf) lower than the force produced by the Instron Dynatup. Therefore, our design would need to absorb 41% of the impact to lower the force to a value under the threshold.

We then set up the Instron machine in accordance with the parameters we solved for in our equations. This entailed a total drop weight of 5kg (11 lbs) and a drop height of 0.46m (18.11 in). The Instron machine measured the time of impact during each test. We found our recorded forces and impact times to be extremely large after a couple trial runs. The time of impact for these tests was 0.0007 seconds, almost six times quicker than our estimation and our forces neared 10,000 lbf (44,482N). Upon lowering the drop height to 0.24 meters (9.44in), we obtained a force lower than 2,250 lbf (10,000 N) produced by the impact tester. When estimating this force with the new height and time of impact, we found that the impact tester should produce 15,500N (3,485 lbf). The difference in our estimation and the actual force seen could be the result of the curved rubber block not being in full contact with the load cell.

## 4.4 Impact Absorption Comparison Test

### 4.4.1 Procedure

To compare the effectiveness of our prototype to commercially available wrist guards, we performed a comparison test. We tested the absorption percentage of our prototype and the protective plastic piece of a Dakine snowboarding wrist guard glove in efforts to determine whether our Zoombang prototype resulted in a similar or higher impact force absorption.

We did not perform the tests in the entire winter glove. The impact absorption added from the glove was assumed to be consistent for each test and was therefore negligible. We tested our pads in the glove liner in order to hold the pads in place and restrict shape deformation during impact, since the deformation would be restricted the same way when the glove is worn on the slopes. We performed six impact trials with only the rubber block under the load cell. In efforts to comply with Schmitt's impact testing, we placed our prototype on both the front and back sides of the curved rubber block peak so that it mimicked both forward and backwards falling [20]. we ran four trials for each.

### 4.5.2 Results

We first tested six iterations of both the control rubber block and the Dakine wrist piece. Figure 27 below depicts the average impact force overtime as well as the average maximum force produced during the tests.

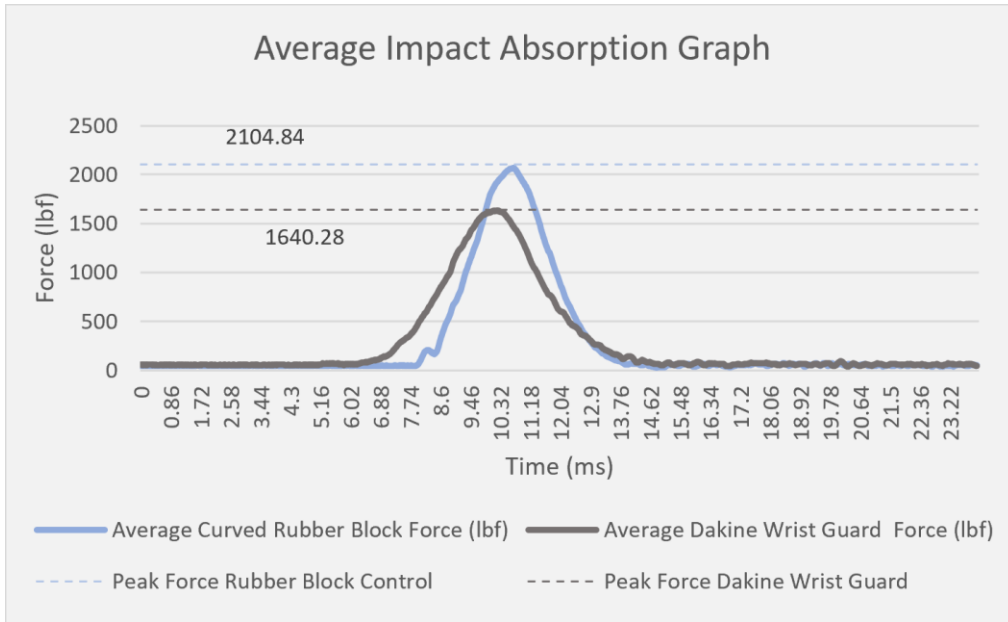

Figure 27. Force absorption for the Dakine guard versus the rubber block control

Shown visibly on the graph, the average maximum force of the Dakine wrist guard measured 1,640 lbf (7296N) where the curved rubber block produced a value of 2,105 lbf (9364N). Using these values, we found an average reduction of transmitted force of 22%.

Figure 28 shows the standard deviation of the Dakine wrist guard compared to the rubber block's standard deviation displayed in a box and whisker plot. The six trials of the Dakine wrist guard impact testing showed forces within 40 lbf (178N) of the average, while the rubber block trials were within 105 lbf (467N) of the average.

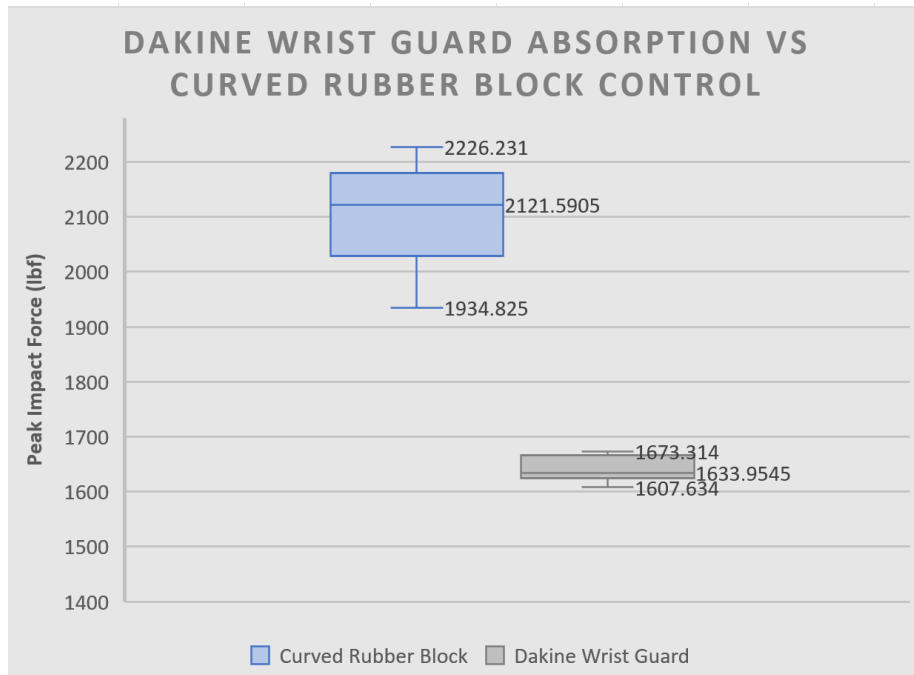

Figure 28. Average and standard deviation of the rubber block versus Dakine wrist guard

We then tested our prototype on the same arched rubber block control. The prototype showed an average absorption of 40%. This included testing from mimicking a forward and backward fall as described in the procedure. The testing was set up so that the prototype was on the upper side of the curve and then the lower side to mimic the difference in falls, however as each trial occurred, the material pushed to one side and changed the thickness of the pad. This then resulted in a higher impact force in the following trial. For example, for backward falls, the first trial produced an absorption of 53% where the last trial decreased to 36%. Because our prototype is a flat pad, in the following test, we switched to testing on a flat rubber block so that the entire bottom surface of the pad would come in contact with the control and the results would more accurately resemble a fall on our prototype.

The purpose of the prototype and Dakine wrist protection testing was to compare absorption percentages. The Dakine wrist guard glove, similar in structure and properties of other conventional wrist guards, showed an average impact force dissipation of 22%. Regardless of the thickness changes observed during testing, the resulting absorption of the prototype was still higher than the wrist guard piece showing promise as an impact absorption material.

## 4.5 Testing for prototype performance after exposure to different temperatures

### 4.5.1 Procedure

An important aspect of the ISO standard is room and cold temperature conditioning. As design specification twelve states, the wrist protector must be exposed to room temperature ( $20\pm 2^{\circ}\text{C}$ :  $68\pm 2^{\circ}\text{F}$ ) for at least four hours, used immediately after for testing and then repeated for cold temperature conditioning ( $-10\pm 2^{\circ}\text{C}$ :  $14\pm 2^{\circ}\text{F}$ ). For the cold-conditioning testing, the prototype should either be immersed in the environment during testing or tested two minutes after exposure to the testing environment. These parameters came directly from the ISO standard for snowboarding devices [40]. Since the wrist device will be used for snowboarding primarily in cold weather, the materials making up the device must be able to withstand a variety of temperatures without drastically changing the effectiveness.

To test how our prototype performed at different temperatures, we compared the performance of our prototype in a room temperature environment to trials conducted after exposing the prototype to two different temperature environments,  $23^{\circ}\text{F}$  ( $-5^{\circ}\text{C}$ ) and  $-4^{\circ}\text{F}$  ( $-20^{\circ}\text{C}$ ). We were not able to reach the exact temperature specified in the ISO standard, therefore, we conducted trials both above and below the temperature.

We conducted each test with the same parameters as described in section 4.2 and 4.3. We used the drop height of 9.45in (0.24m) and tested on the flat rubber block. For the  $25^{\circ}\text{F}$  ( $-5^{\circ}\text{C}$ ) test, we placed our Zoombang sample in a freezer that was set at  $23^{\circ}\text{F}$  ( $-5^{\circ}\text{C}$ ) for over four hours, as specified by the standard. The freezer was located in the same laboratory as the Instron machine, ensuring that the time outside of the cold environment was minimalized. We completed four trials within two minutes of removal from the freezer. We performed the  $-4^{\circ}\text{F}$  ( $-20^{\circ}\text{C}$ ) tests in the same manner as the  $-23^{\circ}\text{F}$  ( $5^{\circ}\text{C}$ ) tests with the exception of the temperature. The prototype was placed in a freezer that was located in the lab and set at  $-4^{\circ}\text{F}$  ( $-20^{\circ}\text{C}$ ).



#### 4.5.2 Results

Figure 29 below depicts the average impact force for each temperature and control as well as the first test for both the -4°F (-20°C) and 23°F (-5°C) tests. For all three temperatures, the average percentage of impact force absorbed ranged from 59-63%. At room temperature, the prototype absorbed an average of 61.2%. At 23°F (-5°C), the prototype absorbed 59.7% and at -4°F (-20°C) the prototype absorbed 62.9% of the impact force.

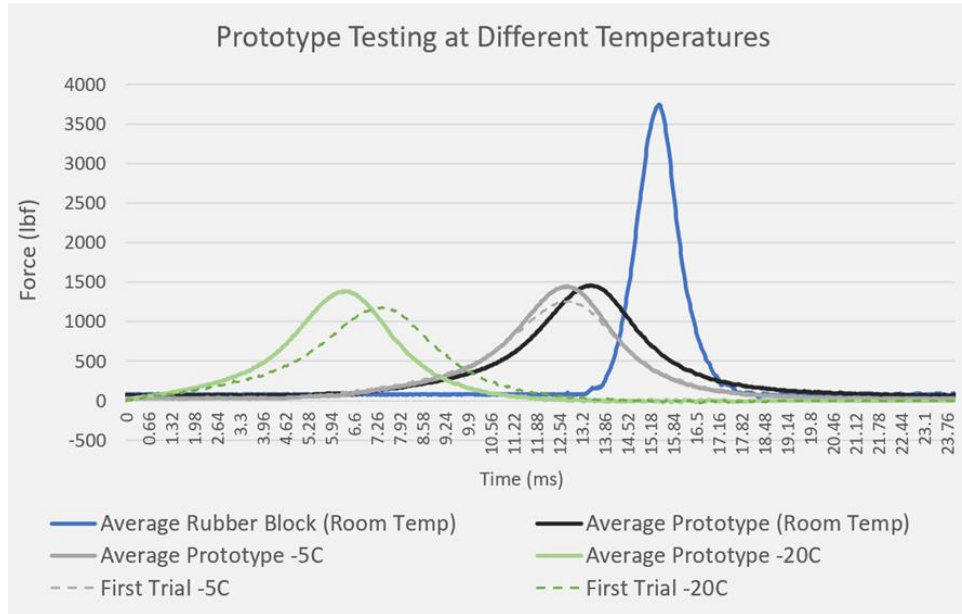

Figure 29. Comparison of impact force at three different temperatures

Both cold temperature tests resulted in a similar average absorption percentage, however the absorption percentage decreased with each consecutive trial during the cold testing. Figure 29 above shows both the first and average impact force graphs. Additionally, the peak impact forces across four trials are shown in Figure 30.

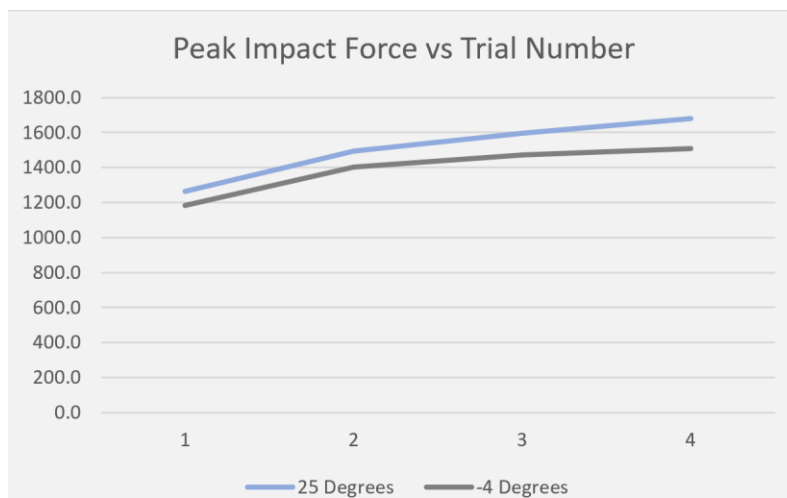

Figure 30. Peak impact force over multiple trials

## 4.6 Testing for Flexibility

To ensure our device did not restrict movement or compromise flexibility, we developed a flexibility test. The simple test ran through a list of questions which were evaluated based on whether the task could be completed. The majority of the tasks were specific to common snowboarding tasks. Below is a list of the tasks we evaluated:

1. Can you make a fist?
2. Can you zip your jacket?
3. Can you buckle your helmet?
4. Can you touch your pinky to your thumb?
5. Can you pick up your snowboarding equipment?
6. Can you strap into the bindings on the snowboard?

The team completed the flexibility test and concluded that the device did not restrict hand motions required to accomplish the tasks listed. The device does not impede finger motion, as the padding is mainly located on the palmar region. We also asked acquaintances at WPI who snowboard to perform the flexibility test. All individuals completed the tasks without restriction.

## Chapter 5: Analysis and Discussion

The purpose of the first test was to compare the impact force absorption of our device to a commercially available wrist guard. For the Dakine wrist guard, we observed a decrease in impact force of 22%. With the same testing procedure, we saw a decrease of 40% for our prototype; however, we were not able to make an accurate comparison between the commercial wrist guard and our impact absorption wrist guard. Testing of our prototype on the arched rubber used for commercial wrist guard testing resulted in an uneven distribution of the Zoombang polymer in our prototype, which yielded inaccurate results. Additionally, the location on the user and mechanism by which each device functions differ. The Dakine wrist guard comes in contact with the forearm of the user, while our design is positioned solely on the palm. The design of the effective portion of the guard, the ABS bump, required a supporting curvature to simulate the proper positioning of the device during impact testing. Testing our device on the same test setup proved to be troubling and led to testing on different shaped blocks; however, regardless of the control and polymer distribution, the prototype still absorbed more impact force than the Dakine commercial wrist guard.

For the testing conducted on the flat rubber block, at room temperature, our prototype absorbed an average of 61.2% of the force produced by the impact. We therefore expect our device to be effective up to 1,300 lbf (5783N) in which our prototype will absorb 61.2% of the impact reducing the force to under 505 lbf (2245N), the force required to break the wrist. Additionally, temperature had no effect in the performance of the prototype. The average impact force reduction was similar at all three temperatures; however, we found a trend at lower temperatures. As we conducted more trials, the amount of force reduced by the prototype decreased. This trend could be explained by the requirements of the standard. The ISO standard states the prototype to be tested in the environment or two minutes after removal from the environment [40]. During our room temperature testing, the prototype was given longer periods of recovery time in between tests as the standard didn't provide a time constraint for testing in the same environment. The material fully regained the original shape in between tests leading to consistent measurements. The ISO standard used for cold environment testing minimized recovery time, and consequently the force measurements from the testing increased after each consecutive impact as the shear thickening properties of Zoombang had not fully recovered from the strain experienced.

We repeated the cold temperature testing for both the -4°F (-20°C) and 23°F (-5°C) temperatures. The results yielded a similar impact force reduction as the initial trials in the previous tests. We concluded that our prototype would reduce impact force consistently given realistic recovery time. Our team does not expect a snowboarder to fall four consecutive times within two minutes. Additionally, the prototype did not break or experience permanent deformation during the entire course of testing.

Aside from reduction in impact force, the ability to recover shape, and ability to work effectively at different temperatures, our prototype met the design specifications stated in section 3.1. The prototype was lightweight (less than 8oz), non-restrictive, and fit inside any winter glove. During the flexibility tests, the users completed all tasks specific to snowboarders and stated they did not feel a difference in comfort or flexibility between wearing the glove with and without the prototype. The inserts of the prototype are removable to allow for washing and contain no sharp edges that could puncture the skin. The prototype covers the danger zones of the hand and did not break during impact testing. Lastly, because the design only includes the snowboarding liner, the cost of the liner would be comparable to other wrist guards on the market.

## Chapter 6: Conclusions and Recommendations

The goal of our project was to create a wrist device that snowboarders are more willing to wear and that does not transfer impact forces to the forearm and elbow. Our prototype reduced impact force more effectively than commercial wrist guards without compromising comfort or flexibility of the user. Temperature did not negatively affect performance and the prototype regained shape within three minutes of recovery time. The prototype has potential to reduce the amount of wrist injuries occurring in snowboarders.

Overall, the final project was successful. We determined shear thickening materials to have the greatest potential to be incorporated into a snowboarding glove. We used ANSYS simulations and the Instron Dynatup 8250 machine to demonstrate proof of concept that stress distribution lowers with increased surface area, and impact force absorption increases with increased thickness. We found an optimal design that balances effectiveness and comfort. On a societal standpoint, a new and innovative design that is more comfortable and effective than traditional wrist guards could dramatically reduce the number of wrist injuries each year. Ethically, using an absorbing material ensures the design does not compromise the elbow or forearm. Lastly, economically, the decision to incorporate the device into a glove liner rather than a glove would allow a snowboarder to only purchase the liner at a lower price and use the glove they already own rather than purchasing a whole new glove. This economic advantage for snowboarders could also increase the likelihood of the protection to be worn.

During the course of our project, our team learned numerous hard and soft skills. We experimented with new testing equipment such as the Instron machine, force scales, and plumb bobs to test for impact force absorption. We increased our knowledge and skills in ANSYS, MatLab, and SolidWorks, and followed an engineering design process that will be useful in our futures.

Future work should consider incorporating a waterproof liner or encapsulation method so the prototype can be used in warmer weather without the entire winter glove. Additionally, knowing the Zoombang properties or using a shear thickening polymer in which the properties are known could determine whether the inserts would need to be removable. It is unknown whether the material could go through the wash but producing and using the glove would be easier if the inserts would not have to be removed and reinserted consistently. Lastly, we found shear thickening materials to have the most potential, but springs and other materials could be further investigated. Specifically, custom springs with new designs that do not exist commercially could be considered as well as air cells with innovative inflation methods.

## Chapter 7: Bibliography

1. Mirhadi, S., Ashwood, N., & Karagkevrekis, B. (2014). Review of snowboarding injuries. *Trauma*,17(3), 175-180.
2. Rust, D., Gilmore, C., & Treme, G. (2013). Injury Patterns at a Large Western United States Ski Resort With and Without Snowboarders: The Taos Experience. *The American Journal of Sports Medicine*, 41(3), 652–656.
3. Basques, B. A., Gardner, E. C., Samuel, A. M., Webb, M. L., Lukasiewicz, A. M., Bohl, D. D., & Grauer, J. N. (2016). Injury patterns and risk factors for orthopaedic trauma from snowboarding and skiing: A national perspective. *Knee Surgery, Sports Traumatology, Arthroscopy*,26(7), 1916-1926.
4. Idzikowski, J. R., Janes, P. C., & Abbott, P. J. (2000). Upper Extremity Snowboarding Injuries. *The American Journal of Sports Medicine*,28(6), 825-832.
5. Russell, K., Meeuwisse, W., Nettel-Aguirre, A., Emery, C. A., Wishart, J., Romanow, N. T., Hagel, B. E. (2013). Characteristics of Injuries Sustained by Snowboarders in a Terrain Park. *Clinical Journal of Sport Medicine*,23(3), 172-177.
6. Yamauchi, Koun et al. “Characteristics of Upper Extremity Injuries Sustained by Falling During Snowboarding: A Study of 1918 Cases.” *The American Journal of Sports Medicine* 38.7 (2010): 1468–1474.
7. Michel, F., Schmitt, K., Greenwald, R., Russell, K., Simpson, F., Schulz, D., & Langran, M. (2013). White Paper: functionality and efficacy of wrist protectors in snowboarding—towards a harmonized international standard. *Sports Engineering*, 16(4), 197–210.
8. Hagel, B., Pless, I., & Goulet, C. (2005). The Effect of Wrist Guard Use on Upper-Extremity Injuries in Snowboarders. *American Journal of Epidemiology*, 162(2), 149–156.
9. Bianchi, Giannina & Michel, Frank & Brügger, Othmar. (2012). The Use of Wrist Guards by Snowboarders in Switzerland. ASTM Special Technical Publication. 1553. 38-53.
10. Lee, S. K. & Kim, S. (2011). Snowboard Wrist Guards—Use, Efficacy, and Design. *Bulletin of the NYU Hospital for Joint Diseases*, 69(2), 149-57.
11. Distal Radius Fractures--Broken Wrist. (2018). Retrieved from <https://orthoinfo.aaos.org/en/diseases--conditions/distal-radius-fractures-broken-wrist/>
12. Boles, C. A., Kannam, S., & Cardwell, A. B. (2000). The Forearm. *American Journal of Roentgenology*,174(1), 151-159.
13. Erwin, J. and Varacallo, M. (2018). StatPearls. StatPearls Publishing.
14. Scheuing Sport AG. (2017). Biomex Protection. Retrieved January, 2019, from <https://www.levelgloves.com/biomex-protection/>
15. Evans, M. (1949). Pronation Injuries of the Forearm. *The Journal of Bone and Joint Surgery*, 31(4), 578-579.
16. Wagner, D., Lindsey, D., & Beaupre, G. (2012). Replicating a Colles fracture in an excised radius: Revisiting testing protocols. *Journal of Biomechanics*, 45(6), 997–1002.
17. Chiu, J., & Robinovitch, S. (1998). Prediction of upper extremity impact forces during falls on the outstretched hand. *Journal Of Biomechanics*, 31(12), 1169–1176.
18. Schmitt, K., Michel, F., Staudig, F. (2011). Analysing the impact behaviour of recent snowboarding wrist protectors. *Ircobi Conference*, (51-61).

19. Lehner, S., Geyer, T., Michel, F. I., Schmitt, K., & Senner, V. (2014). Wrist Injuries in Snowboarding – Simulation of a Worst Case Scenario of Snowboard Falls. *Procedia Engineering*, 72, 255-260.
20. Schmitt, K., Wider, D., Michel, F., Brügger, O., Gerber, H. & Denoth, J. (2012). Characterizing the mechanical parameters of forward and backward falls as experienced in snowboarding. *Sports Biomechanics*, 11(1), 57-72.
21. Deady, L. H., & Salonen, D. (2010). Skiing and Snowboarding Injuries: A Review with a Focus on Mechanism of Injury. *Radiologic Clinics of North America*, 48(6), 1113-1124.
22. Choi, W., & Robinovitch, S. (2011). Pressure distribution over the palm region during forward falls on the outstretched hands. *Journal of Biomechanics*, 44(3), 532–539.
23. Matthews, C. (2018). Best Snowboard Wrist Guards – Which One is Right for Your Wrists? Retrieved September 14, 2018, from <https://homegymr.com/best-snowboard-wrist-guards-one-right-wrists/>
24. All Sport Protection. (2015). How to Choose Snowboard Wrist Guards and Protective Gloves. Retrieved from <https://www.allsportprotection.com/How to Choose Snowboard Wrist Guards Protective Gloves s/225.htm>
25. Kim, S., & Kim, D. (2011). A Study on Fall Simulation and Shock Absorption Systems for the Development of a Fracture Prevention System. *Applied Mechanics and Materials*, 145, 384–389.
26. Rønning, R., Rønning, I., Gerner, T., & Engebretsen, L. (2001). The Efficacy of Wrist Protectors in Preventing Snowboarding Injuries. *The American Journal of Sports Medicine*, 29(5), 581–585.
27. O’Neill, D. (2003). Wrist Injuries in Guarded Versus Unguarded First Time Snowboarders. *Clinical Orthopedics and Related Research* 409, 91-95.
28. Machold, W., Kwasny, O., Eisenhardt, P., Kolonja, A., Bauer, E., Lehr, S., Mayr, W., Fuchs, M (2002). Reduction of Severe Wrist Injuries in Snowboarding by an Optimized Wrist Protection Device: A Prospective Randomized Trial. *The Journal of Trauma: Injury, Infection, and Critical Care* 52(3), 517-520.
29. Maurel, M., Fitzgerald, L., Miles, A., & Giddins, G. (2013). Biomechanical study of the efficacy of a new design of wrist guard. *Clinical Biomechanics*, 28(5), 509–513.
30. Kim, K., Alian, A., Morris, W., & Lee, Y. (2006). Shock Attenuation of Various Protective Devices for Prevention of Fall-Related Injuries of the Forearm/Hand Complex. *The American Journal of Sports Medicine*, 34(4), 637–643.
31. Russell K, Hagel B, Francescutti LH. The effect of wrist guards on wrist and arm injuries among snowboarders: a systematic review. *Clin J Sport Med*. 2007;17(2):145-50.
32. Cheng, S., Rajaratnam, K., Raskin, K., Hu, R., Axelrod, T. (1995). "Splint-Top" Fracture of the Forearm: A Description of an In-Line Skating Injury Associated with the Use of Protective Wrist Splints. *The Journal of Trauma: Injury, Infection, and Critical Care*, 39(6), 1194-1197.
33. Staebler, M., Moore, D., Akelman, E., Weiss, A., Fadale, P., & Crisco, J. (1999). The Effect of Wrist Guards on Bone Strain in the Distal Forearm. *The American Journal of Sports Medicine*, 27(4), 500–506.
34. Hwang, I. K., & Kim, K. J. (2004). Shock-absorbing effects of various padding conditions in improving efficacy of wrist guards. *Journal of sports science & medicine*, 3(1), 23-9.
35. Raghavan, S., & Khan, S. (1997). Shear-thickening response of fumed silica suspensions under steady and oscillatory shear. *Journal of Colloid and Interface Science*, 185(1), 57–67.

36. Gürgen, S., Kuşhan, M. C., & Li, W. (2017). Shear thickening fluids in protective applications: A review. *Progress in Polymer Science*, 75, 48-72.
37. Galindo-Rosales, F., Martínez-Aranda, S., & Campo-Deaño, L. (2015). CorkSTF $\mu$ fluidics – A novel concept for the development of eco-friendly light-weight energy absorbing composites. *Materials & Design*, 82, 326-334.
38. Soutrenon, M., & Michaud, V. (2014). *Impact absorption of composites with Shear Thickening Fluid Filled Foams*. In *The 19th International Conference on Composite Materials*. Retrieved from <http://confsys.encs.concordia.ca/ICCM19/AllPapers/FinalVersion/MIC80806.pdf>
39. Zoombang Inc. (2018). Home page. Retrieved from <https://www.zoombang.com/>
40. ISO/DIS 20320 - Protective clothing for use in Snowboarding (2018). Retrieved from <https://www.iso.org/standard/67665.html>
41. Oberg, Erik Jones, Franklin D. Horton, Holbrook L. Ryffel, Henry H.. (2016). *Machinery's Handbook (30th Edition)*. Industrial Press. Retrieved from <https://app.knovel.com/hotlink/toc/id:kpMHE00024/machinerys-handbook-30th/machinerys-handbook-30th>
42. Ramirez, J. G. (2004, May). *Characterization of Shear-Thickening Fluid-Filled Foam Systems for Use in Energy Absorption Devices* [Scholarly project]. In *Www.mit.edu*. Retrieved from <https://dspace.mit.edu/bitstream/handle/1721.1/32777/57570918-MIT.pdf?sequence=2>
43. United States Plastic Corp. (2019). LDPE Sheet. Retrieved February, 2019, from [https://www.usplastic.com/catalog/item.aspx?sku=46550&gclid=Cj0KCQiAzKnjBRDPARIsAKxfTRCH0IBH9CzQ-90xHCydQ1dMthpmEmucj\\_pfcYyJxQgdTs17eWz6doQaAjQEEALw\\_wcB](https://www.usplastic.com/catalog/item.aspx?sku=46550&gclid=Cj0KCQiAzKnjBRDPARIsAKxfTRCH0IBH9CzQ-90xHCydQ1dMthpmEmucj_pfcYyJxQgdTs17eWz6doQaAjQEEALw_wcB)
44. LDPE. (2019). Retrieved February, 2019, from <https://www.curbellplastics.com/Research-Solutions/Materials/LDPE>
45. Latex vs Nitrile vs Vinyl Gloves...Which to Choose? (2016, July 29). Retrieved from <https://b4brands.com/blog/latex-vs-nitrile-vs-vinyl-gloves-which-to-choose/>

## Appendix I: Examples of Commercially Available Wrist Guards

Discussed below are examples of wrist guards and the unique features of each design:

- I. The Soared Skating Impact Wrist Guard: The soared skating impact wrist guard combines using a stiff ABS plastic with a soft lycra mesh to provide protection without compromising comfort and flexibility. The guard prevents over extending of the wrist in the extension and flexion directions and was specifically designed to not negatively impact blood flow. The lycra mesh is stretchy and breathable, allowing for more movement and better moisture control. There are additional velcro straps to adjust the tightness of the guard. A drawback of this design is the bulkiness [23].



Figure X: Soared Wrist Guard

- II. The Burton Impact Wrist Guard: The Burton impact guards are highly padded with nitrile rubber (NBR), polyester, Nylon, and polyethylene, making the product flexible, lightweight, and comfortable. The soft pad palms and tapered splints contribute to the comfort and pliability. However, the edges are not refined and can lead to scratches and discomfort. Nevertheless, the guard has impressive shock absorbing qualities and works effectively [23].





Figure X: Burton Wrist Guard

- III. The Flexmeter Wrist Guard: The flexmeter wrist guard is designed to easily fit underneath a snowboarding glove. The guard offers support along the length of the forearm as well as the wrist. Unlike the other wrist guards, the flexmeter has one-sided support which leaves the hand free from a stiff material. This allows for a better grip and more flexibility. The drawback of the Flexmeter is the price point [23].

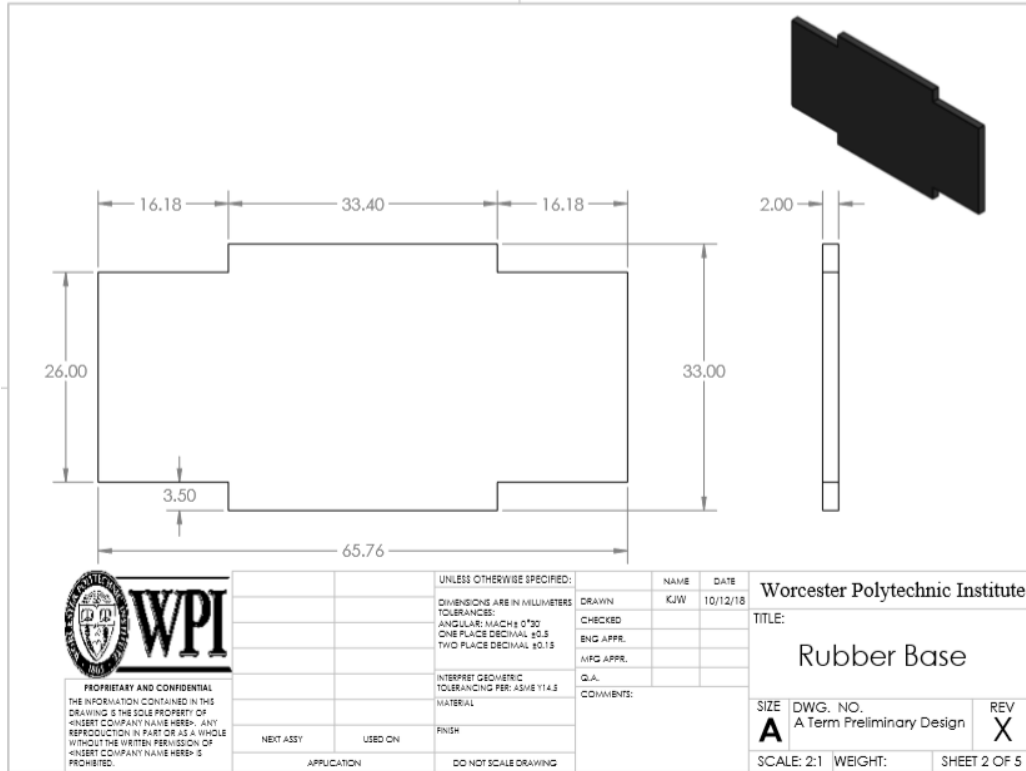

Figure X: Flexmeter Wrist Guard

- IV. Triple8 Saver Series Wrist Guards: The Triple8 series wrist guard is unique in the materials used. The design includes the typical built-in splints for support, but uses a shock-absorbing ethylene-vinyl acetate (EVA) foam that cushions the hand and wrist. The downsides to this design are the lack of breathability and flexibility compared to other wrist guards [23].







Impact Absorption Device Assembly Drawing 2

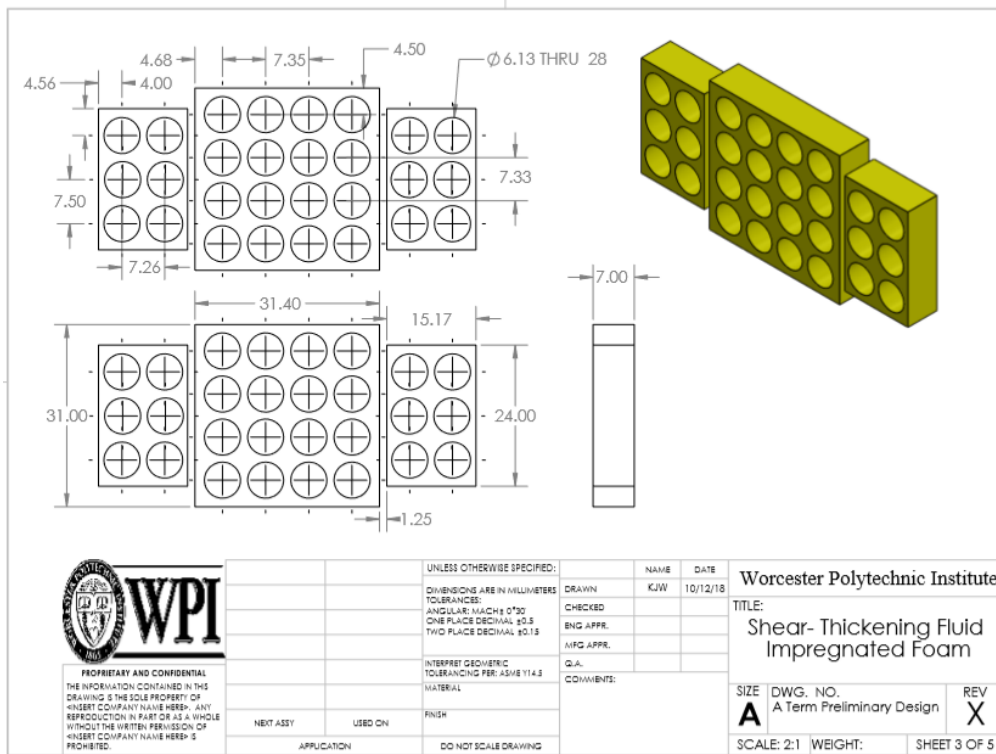

Impact Absorption Device Assembly Drawing 3

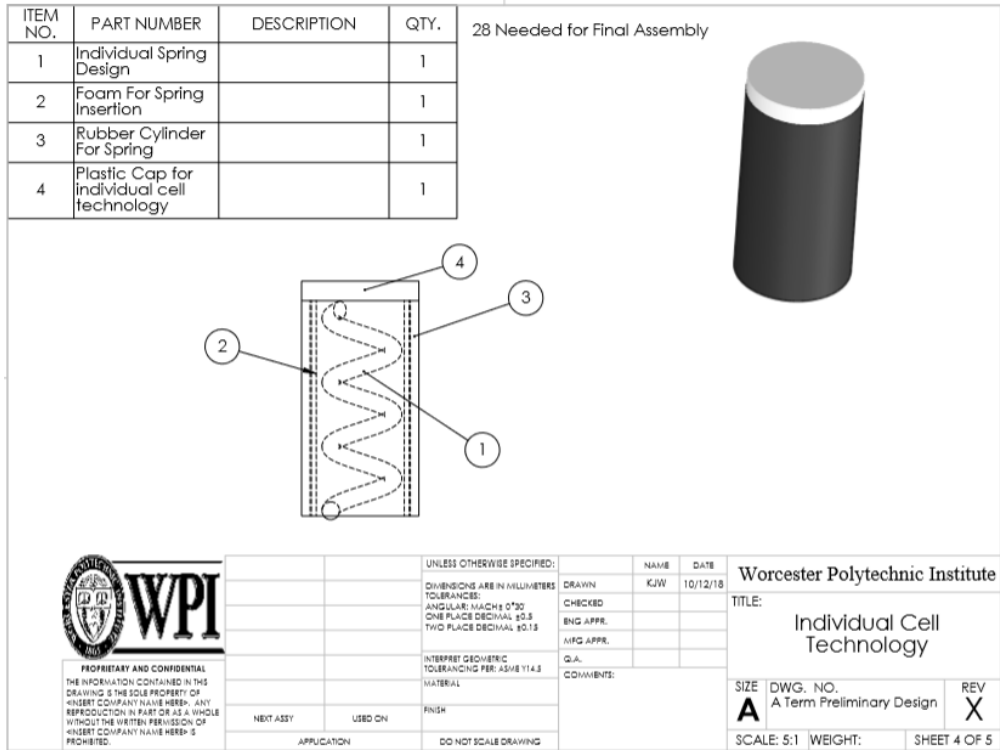

Impact Absorption Device Assembly Drawing 4

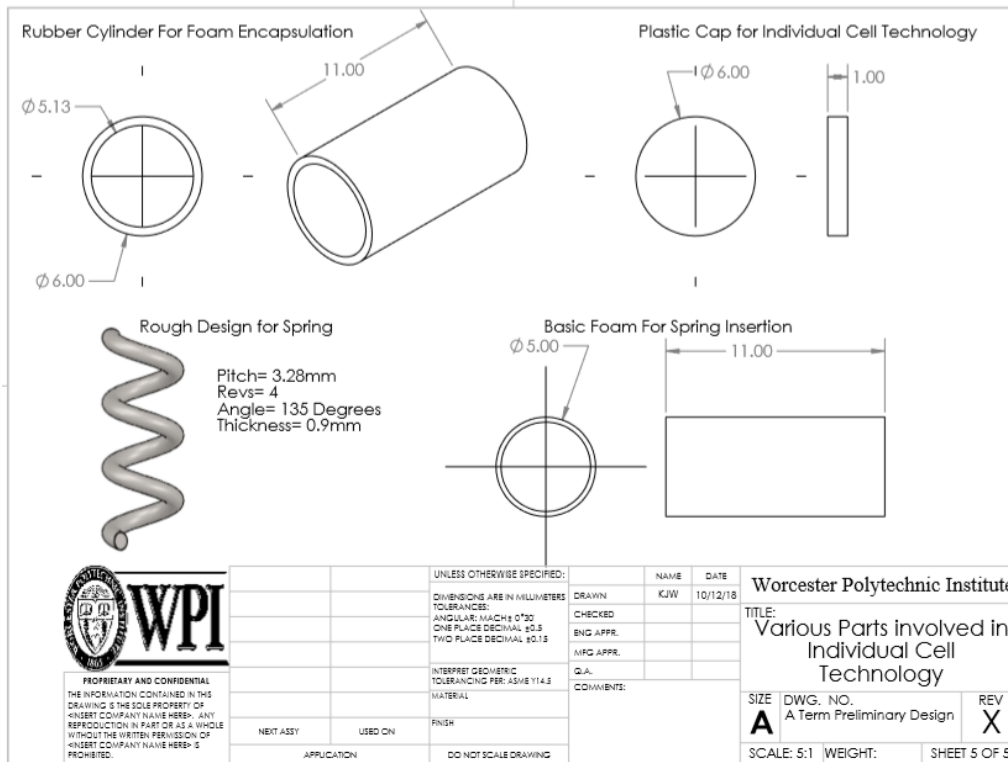

Impact Absorption Device Assembly Drawing 5