

2004-01-14

A Novel Non-Acoustic Voiced Speech Sensor: Experimental Results and Characterization

Kevin Michael Keenaghan
Worcester Polytechnic Institute

Follow this and additional works at: <https://digitalcommons.wpi.edu/etd-theses>

Repository Citation

Keenaghan, Kevin Michael, "A Novel Non-Acoustic Voiced Speech Sensor: Experimental Results and Characterization" (2004). *Masters Theses (All Theses, All Years)*. 96.
<https://digitalcommons.wpi.edu/etd-theses/96>

This thesis is brought to you for free and open access by Digital WPI. It has been accepted for inclusion in Masters Theses (All Theses, All Years) by an authorized administrator of Digital WPI. For more information, please contact wpi-etd@wpi.edu.

A NOVEL NON-ACOUSTIC VOICED SPEECH SENSOR:
EXPERIMENTAL RESULTS AND CHARACTERIZATION

by

Kevin Michael Keenaghan

A Thesis

Submitted to the Faculty

of the

WORCESTER POLYTECHNIC INSTITUTE

in partial fulfillment of the requirements for the

Degree of Master of Science

in

Electrical and Computer Engineering

February 2004

Professor Donald Richard Brown III, Advisor

Professor Edward Clancy, Committee

Professor Reinhold Ludwig, Committee

© 2004 Kevin Michael Keenaghan

ALL RIGHTS RESERVED

To Mom, Dad, and Kris.

ABSTRACT

Recovering clean speech from an audio signal with additive noise is a problem that has plagued the signal processing community for decades. One promising technique currently being utilized in speech-coding applications is a multi-sensor approach, in which a microphone is used in conjunction with optical, mechanical, and electrical non-acoustic speech sensors to provide greater versatility in signal processing algorithms. One such non-acoustic glottal waveform sensor is the Tuned Electromagnetic Resonator Collar (TERC) sensor, first developed in [BLP⁺02]. The sensor is based on Magnetic Resonance Imaging (MRI) concepts, and is designed to detect small changes in capacitance caused by changes to the state of the vocal cords — the glottal waveform. Although preliminary simulations in [BLP⁺02] have validated the basic theory governing the TERC sensor’s operation, results from human subject testing are necessary to accurately characterize the sensor’s performance in practice.

To this end, a system was designed and developed to provide real-time audio recordings from the sensor while attached to a human test subject. From these recordings, executed in a variety of acoustic noise environments, the practical functionality of the TERC sensor was demonstrated. The sensor in its current evolution is able to detect a periodic waveform during voiced speech, with two clear harmonics and a fundamental frequency equal to that of the speech it is detecting. This waveform is representative of the glottal waveform, with little or no articulation as initially hypothesized. Though statistically significant conclusions about the sensor’s immunity to environmental noise are difficult to draw, the results suggest that the TERC sensor is considerably more resistant to the effects of noise than typical

acoustic sensors, making it a valuable addition to the multi-sensor speech processing approach.

BIOGRAPHICAL SKETCH

Bright and early on the morning of September 3, 1980, Kevin Michael Keenaghan decided it was high time he blessed the world with his presence. He was born to Kathy and Ted Keenaghan, two amazing people by all accounts, in scenic Pawtucket, Rhode Island. Early on, Kevin began to display his affinity for unusual sleep habits, a tendency that would follow him throughout life and eventually be the bane of his Masters advisor's existence. While most parents fretted over trying to get their babies to sleep, Kevin's father would come home from work at 5pm and have to wake him up just so he could play with him for a while!

Kevin made it through high school in a relatively uneventful manner, impressing teachers not only with his abilities but also with a strong case of *senioritis* that began soon after the start of his Freshman year. Luckily he was able to finally outgrow the illness and become motivated towards the end of high school (much to the relief of his parents, who had no doubt come close to several nervous breakdowns over the course of the four years). It was during this senior year of newfound motivation that Kevin and his family made that fateful visit to Worcester Polytechnic Institute. He decided right there and then that WPI was the perfect college for him. Luckily for him, he was accepted. Luckily for his parents, he got scholarships and financial aid.

Not long after entering WPI, Kevin made the very intelligent decision to go into Electrical Engineering, and was quickly introduced to not only a great academic program, but also amazing teachers like Professor Rick Vaz, his undergraduate advisor. On a non-academic level, he also made the decision to join the Lambda Chi Alpha Fraternity, a highly unlikely decision by one who entered college as a self-proclaimed GDI, but which turned out to be one of the best decisions of his life.

When not immersed in books (academic or otherwise), Kevin spent his college time gallivanting around the world doing school projects in Costa Rica and Ireland. As he neared graduation, he was introduced to the inimitable Professor Rick Brown, and made the decision to continue on for a Masters degree - a decision inspired partly by his desire to eventually become a college professor, and partly by the absolutely miserable job market at the time.

Other than the inevitable clashes that occur when a student with a penchant for sleeping late teams up with an advisor who wakes the rooster up on his way to work, Kevin managed to make it through his Masters program with very few hitches and get involved with some great research. He was invited to work on this project, which offered him a chance to not only work on some cutting-edge research, but also to work under the tutelage of Professor Brown once again.

At the time he wrote this thesis, Kevin was weighing his options for employment offers, and gearing up to finally get out into the “real world” he kept hearing so much about.

ACKNOWLEDGEMENTS

I cannot begin to say how grateful I am to my family for their constant love, support, and encouragement during not only my academic career but throughout my life. Without them, I could never have made it this far or accomplished what I have. Thanks for always being my role models and the people I aspire to be like when I finally decide to “grow up,” and for always listening to me ramble on incessantly about things that I don’t even totally understand myself!

I am forever indebted to my thesis advisor, Professor Rick Brown, for his support and assistance throughout this project and the rest of my Masters degree, and for getting me back on track during those occasional times when the light at the end of the tunnel seemed to be too far away to reach. Thanks for your advice and friendship, and for passing “*Raulisms*” on to a whole new generation of engineers. Thanks also to the members of my thesis committee, Professors Ted Clancy and Reinhold Ludwig, for their advice, input, and support during this project.

Finally, I owe a great debt of gratitude to the Defense Advanced Research Projects Agency (DARPA) for supporting the project and making this thesis research possible, and to the members of the Advanced Speech Encoding (ASE) program, especially Paul Gatewood at Arcon Corp, for their input and help.

TABLE OF CONTENTS

Biographical Sketch	v
Acknowledgements	vii
Table of Contents	viii
List of Tables	x
List of Figures	xi
1 Introduction	1
1.1 Motivation	3
1.2 Thesis Contributions	4
1.3 Thesis Content	5
2 Background	8
2.1 Speech Production	8
2.1.1 The Anatomy of Speech Production	8
2.1.2 Voiced Speech Production	10
2.1.3 The Physics of Speech	13
2.2 Glottal Waveform Sensors	14
2.2.1 The Physiological Microphone	16
2.3 Intelligibility Tests	18
2.3.1 Word List Tests	18
2.3.2 Sentence List Tests	24
2.3.3 Conversational Tests	26
2.4 Signal Processing Background	26
2.4.1 Signal-to-Noise Ratio	27
2.4.2 Pitch Detection and Tracking	29
3 TERC Sensor System Design	31
3.1 Principles of Operation	31
3.2 TERC System Setup	34
3.2.1 Network Analyzer Tests	35
3.2.2 Demodulation System Design	38
4 Data Acquisition System Design and Test Procedures	42
4.1 Context and Experimental Apparatus	42
4.2 Sound Field Generation	45
4.2.1 Sound Generation System	47
4.3 Recording System Setup	47
4.4 Testing Procedures	50
4.4.1 Human Subject Considerations	50
4.4.2 Types of Tests Performed	52
4.4.3 Recording Time	56

4.4.4	Limitations of Testing	59
5	Results and Conclusions	63
5.1	Results	63
5.1.1	General Performance Results	63
5.1.2	SNR Results	71
5.1.3	Pitch Detection	75
5.2	Conclusions	79
5.2.1	Contributions of Research	79
5.2.2	Performance and Recommendations	81
A	Speech Intelligibility Tests	84
A.1	Harvard Psychoacoustic Sentence Lists	84
A.2	Diagnostic Rhyme Test Stimulus Words	92
A.3	Phonetically Balanced (PB-50) Word Lists	93
A.4	Sustained Vowel Word Lists	98
B	WPI Pilot Corpus	99
	Bibliography	100

LIST OF TABLES

4.1	Noise Environments and SPL Readings	47
4.2	Recording Time for the Sustained Vowel Lists	56
4.3	Recording Time for the Harvard Sentence Lists	57
4.4	Recording Time for the Diagnostic Rhyme Tests	58
4.5	Recording Time for the PB-50 Word Lists	59
4.6	Total Recording Time for One Noise Environment	59
A.1	DRT Stimulus Words	92
A.2	PB-50 Word Lists	93
A.3	Vowel Word Lists	98

LIST OF FIGURES

1.1	Signal processing techniques using only one microphone.	1
1.2	Signal processing techniques using multiple microphones.	2
1.3	Signal processing techniques using multiple sensors.	2
2.1	Lateral view of the human vocal organs.	9
2.2	Approximation of the glottal waveform.	11
2.3	Frequency response of the glottal waveform.	12
2.4	Shape of the lips for various vowel sounds.	13
2.5	The Physiological Microphone (PMIC).	17
3.1	Simplified model of the human neck.	32
3.2	Theoretical resonance shift due to glottal state changes.	33
3.3	Concept behind the TERC sensor's operation.	34
3.4	Baseband glottal signal as seen on Network Analyzer.	36
3.5	Network Analyzer tests with circulator.	38
3.6	Diode/capacitor envelope detector circuit.	39
3.7	Signal Acquisition Setup for the TERC Sensor.	40
4.1	Interior layout of the sound booth during testing.	43
4.2	Physical location of the TERC sensor on a human subject's neck.	44
4.3	Environmental Noise Production System Setup.	48
4.4	Recording System Setup.	49
4.5	Effect of resonance shifts on the TERC output.	60
5.1	Time domain comparison between microphone and TERC signals.	64
5.2	Low frequency signal content prior to voiced speech.	65
5.3	Delay between the TERC and microphone signals.	66
5.4	Example of delay through the WinRadio package.	67
5.5	Nulls in background noise in spectrograms of TERC sensor.	67
5.6	Spectrogram of frequency sweep with "spatial" setting.	68
5.7	Spectrogram of frequency sweep without "spatial" setting.	69
5.8	PSD of frequency sweep with "spatial" setting.	70
5.9	PSD of frequency sweep without "spatial" setting.	70
5.10	SNR versus SPL measurements for three sensors.	73
5.11	Comparison of PSD for microphone and TERC sensors.	75
5.12	Spectrogram of vowel word list in quiet environment.	76
5.13	Spectrogram of vowel word list in BHH environment.	77
5.14	Spectrogram of vowel word list in M2H environment.	77

CHAPTER 1

INTRODUCTION

One of the oldest and most common problems in the signal processing field is the issue of how to derive a clean speech signal from one plagued with background noise. There have been any number of methods developed to derive the best possible approximation of the clean speech signal under adverse conditions. Traditional signal processing techniques involved only a single noisy speech signal as their input, as illustrated in Figure 1.1:

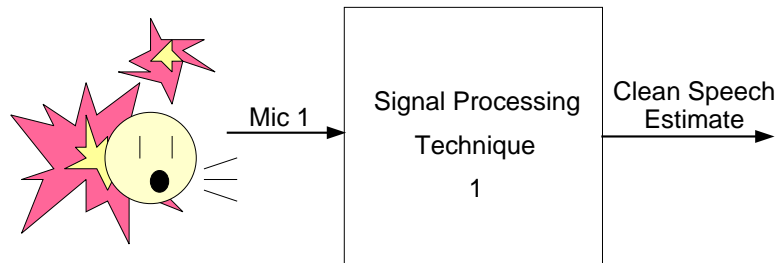

Figure 1.1: Traditional signal processing techniques using only one microphone.

Although many of these single-microphone techniques are still employed successfully (e.g. spectral subtraction or adaptive filtering techniques as described in [Fan02]), the performance of these techniques degrades significantly in the presence of a high acoustic noise environment. However, by modifying the model in Figure 1.1 to include multiple microphone inputs, as shown in Figure 1.2, more complex and effective signal processing techniques can be employed along with the traditional techniques to improve the performance of the system.

Even with the improved performance of multiple-microphone signal processing techniques (e.g. beamforming, as described in [Fan02]), such a system's suscep-

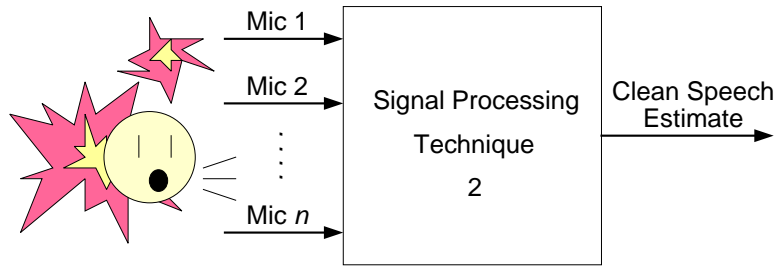

Figure 1.2: Signal processing techniques using multiple microphones in an array. tibility to environmental noise is still high when using only traditional acoustic microphones. Rather than assuming that the input to the system has to be an array of acoustic microphones, the model in Figure 1.2 can be amended to include more generic “sensor” inputs:

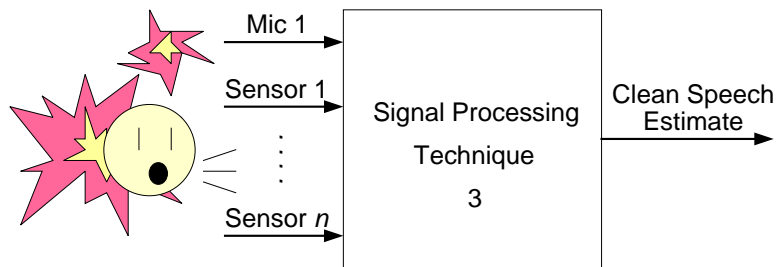

Figure 1.3: Signal processing techniques using a multiple sensor array.

An acoustic microphone is limited in its efficacy for signal processing techniques in high noise environments. As the background noise increases, so too does the difficulty of deriving a clean speech signal from the noisy signal using traditional microphones. Replacing some of the microphone inputs in Figure 1.2 with newer non-traditional speech sensors could significantly improve the performance of the techniques.

One family of sensors that could be incorporated into the system in Figure 1.3 is the family of non-acoustic speech sensors, which measure particular elements of speech without detecting invasive environmental background noise. Initial forays into this field, such as a laryngoscope with which one could view the movements of the vocal cords [Gar55] directly, proved clinically interesting but functionally problematic. The initial sensors were either too cumbersome or uncomfortable to use during normal vocalization. While they provided a great deal of insight into the speech production process, they were simply inadequate for the intricacies of speech processing as it is known today.

Newer non-acoustic sensors like the electroglottogram (EGG), the Glottal Electromagnetic Micropower Sensor (GEMS) [Bur99], and the Physiological Microphone (PMIC) [Sca98] can each be used as a transducer to measure the glottal waveform — a signal representative of perturbations of the vocal cords occurring during voiced speech. This waveform can be used as a proxy for the actual acoustic speech signal. Many of these sensors, while considered large steps forward in the field, are susceptible to placement issues due to their small size and sensitivity..

1.1 Motivation

In 2003, researchers at the Worcester Polytechnic Institute developed a new non-acoustic glottal waveform sensor named the Tuned Electromagnetic Resonator Collar (TERC) sensor, which uses changes to the integrated dielectric properties of the neck occurring due to the opening and closing of the vocal folds to measure the glottal state (refer to [BLP⁺02] and [Pel04]). Fundamentally based on magnetic resonance imaging (MRI) concepts, the TERC sensor introduces a new approach to

the issue of glottal waveform measurement. Since the TERC sensor was designed to measure changes in the dielectric properties of a cross-section of the neck rather than skin vibrations or any kind of acoustic waveform derivative, the initial hypothesis by the researchers was that it would be relatively impervious to the effects of environmental noise.

Though preliminary simulations validated the basic concepts defining the TERC sensor's operation [Pel04], no efforts had been made to accurately characterize the sensor's performance or, in fact, prove that the theory could actually be applied in practice.

1.2 Thesis Contributions

One of the major goals of this research, then, was to test the TERC sensor in a laboratory setting with human test subjects in order to characterize its performance. The accomplishment of this goal, however, was reliant on the realization of several other interrelated goals:

1. The design and construction of a demodulation system based on the operation of the TERC sensor to provide the analog acoustic waveform representing the glottal waveform.
2. The design and construction of sound generation and data acquisition systems to record the analog acoustic signal from the TERC sensor for subsequent signal processing applications.
3. The development and execution of human subject experiments with the TERC sensor in controlled acoustic environments to create a data set of speech

recordings

4. The organization, formatting, and distribution of the corpus of data collected during the experimental phase of the research
5. The evaluation and characterization of the TERC sensor's performance based on the recordings in the data set

There are several important deliverables that resulted from the actualization of these goals. The first is the data acquisition and demodulation systems that allowed for the recordings from the TERC sensor to ultimately be made. The second was the actual corpus of data, consisting of roughly two and a half hours of audio recordings for three different sensors, which were used to characterize the sensor's performance.

Finally, the results and conclusions presented in this document define the level of performance of the TERC sensor in its current form, and also provide recommendations for future research possibilities to improve this performance.

1.3 Thesis Content

The major content of this document is divided into five chapters, including one of the appendices, in a logical, rather than chronological, presentation of the research. There is a great deal of information relating to the speech process and signal processing techniques which will aid the reader in fully understanding the methods and concepts in this research. Chapter 2 presents this information as a background chapter, which can be read in as little or as much depth as necessary to augment the research in subsequent chapters.

Because the entire focus of this research is related to the TERC sensor, a full understanding of the theory of operation behind the sensor and its practical implementation is necessary to fully appreciate the contributions of this research. Chapter 3 explains the operation of the TERC sensor, and describes the development of the demodulation circuitry necessary to obtain an audio signal from the sensor.

Chapter 4 describes the development and execution of the experimental testing procedure used to record the TERC sensor signals during speech, which is divided into several areas of focus. Following an overall description of the purpose of the tests, the development of the sound generation and acquisition systems that allow the sensor signals to be digitally recorded are described. In addition, the specific tests performed and any considerations with dealing with human test subjects are presented.

The results of this testing, along with any conclusions drawn from these results, are presented in Chapter 5. Along with the general objective and subjective results about the sensor's performance, additional results relating to the specific signal processing applications of signal-to-noise ratios and pitch detection are presented as well. The conclusions about the sensor's performance are augmented with recommendations for future research opportunities based on the results of this research.

Finally, since various word and sentence lists were utilized in the development of the data recordings, the corpus data cannot be interpreted or analyzed fully without knowing which specific lists were used. As such, Appendix A presents these lists in their entirety as supplemental information.

Before delving into the design of the experimental procedure and the ultimate

characterization of the TERC sensor's performance, however, it is necessary to provide a solid foundation of the signal processing and speech production concepts that will be applied throughout this research.

CHAPTER 2

BACKGROUND

Before one can delve into the specific procedures and results of this research, it is important to first be familiar with some directly related background information. None of the concepts in this chapter were developed during this research, but are intended to provide readers with a solid understanding of the theories and practices employed in subsequent chapters.

2.1 Speech Production

The principal function of the organs which make up the vocal tract is to aid in the respiratory and digestive functions of the body. However, through a modification of the respiratory process, these organs can be used to produce the sounds of human speech.

2.1.1 The Anatomy of Speech Production

At the top of the vocal tract (see Figure 2.1) are the nasal cavity and the mouth, containing the lips, teeth, tongue, and hard palate. The nasal cavity and mouth meet posteriorly at the end of the soft palate, which can move and block the flow of air from the lungs to the nasal cavity for some non-nasal sounds during speech. Collectively, these organs produce the majority of the changes in the shape of the vocal tract, known as articulatory movements, which produce the sounds of human speech. Connecting the mouth and the nasal cavity is the pharynx, which extends down to the top of the larynx, near the epiglottis. Though the pharynx can change

shape during speech, not a great deal is known about how the modifications in shape affect the sounds produced [DP93].

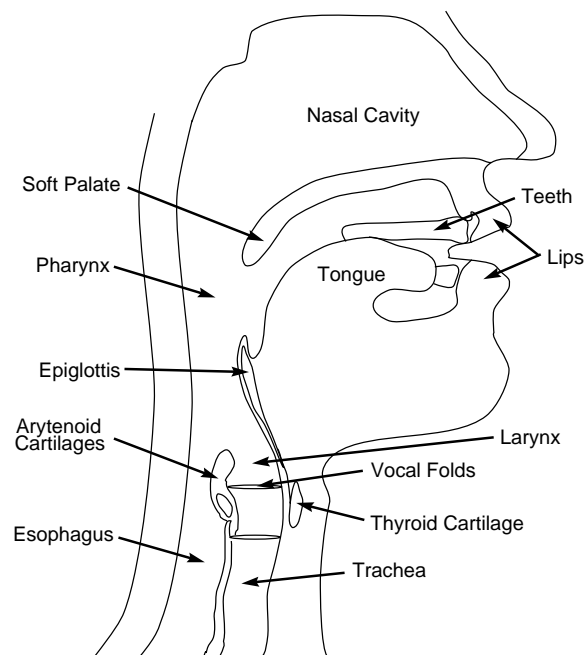

Figure 2.1: Lateral view of the human vocal organs.

The larynx is essentially a stack of cartilage rings located above the trachea and below the pharynx, the most prominent of which is the thyroid cartilage, commonly known as the “Adam’s apple.” At the top of the larynx is the epiglottis, used to help deflect food from the trachea during swallowing. Below the epiglottis are the vestibular folds [RGR97], or “false vocal cords,” which are connected anteriorly to the thyroid cartilage and posteriorly to the arytenoid cartilages. These folds can open and close, but are not thought to aid in the speech process. Below the vestibular folds are the vocal folds, or “vocal cords,” which are connected in the same manner. The vocal folds and the gap between them are known collectively as the “glottis.” Through the movement of the arytenoid cartilages, these folds can

open fully (as during respiration), close fully (as during swallowing), or open and close rapidly (as during voiced speech production).

2.1.2 Voiced Speech Production

There are three primary methods of speech production. The first involves partially blocking the path of air from the lungs, causing it to “hiss” through the constricted path. This technique is used to create fricatives (e.g. teeth to lips for the /f/[†] in “*effort*” or tongue to hard palate for the /s/ in “hiss”). The second involves completely blocking the path of air from the lungs momentarily and then releasing the flow in one forceful sound. This technique is used to create plosives (e.g. lips together for the /p/ in “*push*” or tongue to hard palate for the /t/ in “*time*”). The final method of speech production is used for voiced speech, which can also be combined with the previously named methods to create additional sounds (e.g. voiced fricatives such as the /v/ in *very* or voiced plosives such as the /d/ in *dog*).

During voiced speech the vocal folds are held closed, forcing a buildup of air pressure from the lungs. The folds are eventually forced open, expelling a burst of air and releasing the pressure. They can then return to the closed position, initiating the buildup of pressure again. This effectively segments the flow of air from the lungs into brief puffs, which can be heard as an audible buzz whose fundamental frequency depends on the frequency at which the vocal folds open and close. By altering the length and tension of the vocal folds and the air pressure from the lungs, one can alter the fundamental frequency at which this cycle occurs, and thus the frequency of the resulting sound.

[†]The symbol /·/ refers to one of the phonemes of General American English defined in Table 2.1 of [DP93].

During normal speech this fundamental frequency is in the range of around 60 Hz to 500 Hz, averaging approximately 265 Hz, 225 Hz, and 120 Hz for children, women, and men, respectively [Fry79] (which equate to roughly a “middle C,” “A below middle C,” and “two B’s below middle C,” in musical notation). Normally people use about an octave of range during speech, generally in the lower portion of their total voice range.

The airflow during one glottal cycle is described in [Fry79] as follows:

“[T]he rise from zero to about 700cm^3 takes just over 2 ms. As the cords begin to close together again, the airflow diminishes but at a somewhat slower rate, taking over 3 ms to return to zero, and it remains at zero for just over 3 ms before beginning the cycle again.”

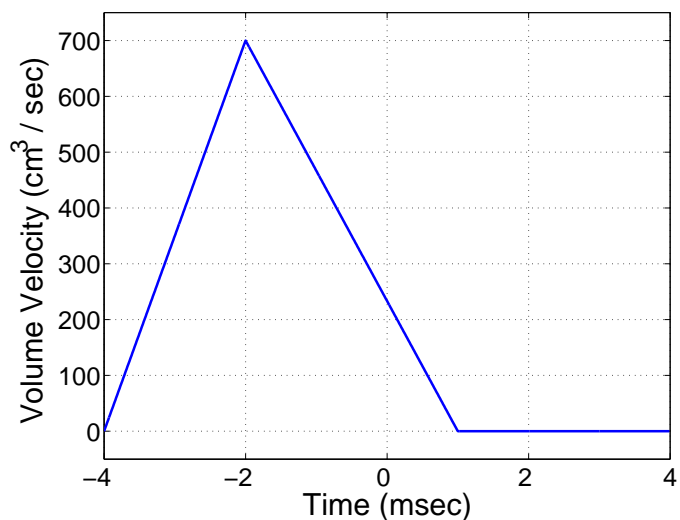

Figure 2.2: Generalized approximation of the air flow during one period of the glottal waveform.

It is interesting to study the transfer function of a continuous waveform of these

puffs of air, the “glottal waveform,” in order to better understand the speech process. For simplicity’s sake, one can approximate the glottal waveform with that seen in Figure 2.2, centered at time $t = 0$ with a period of $T = 8\text{ms}$ and an amplitude of $700\text{cm}^3/\text{sec}$, as shown in Figure 2.2. The magnitude and phase response for this waveform can be seen in Figure 2.3, where $f_0 = 1/T$.

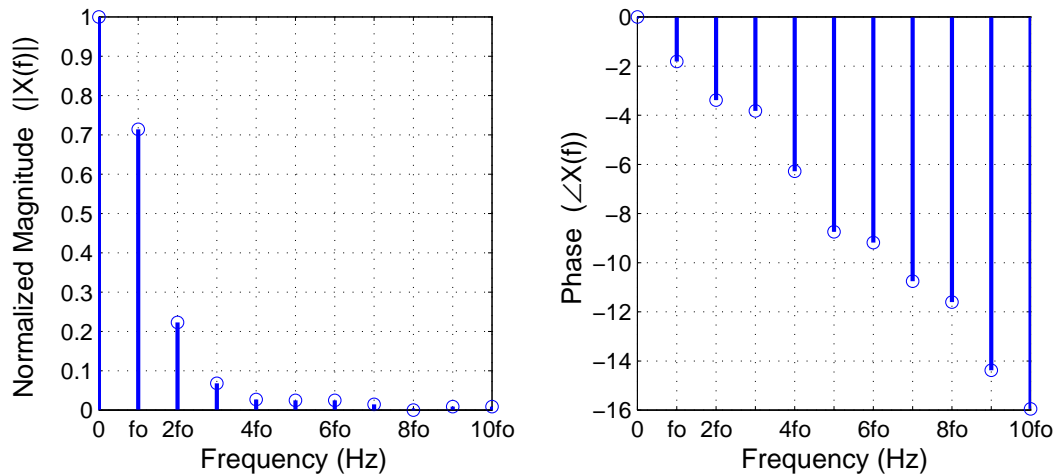

Figure 2.3: Approximate frequency response of the glottal waveform.

Since the approximate glottal waveform in Figure 2.2 is closely related to a triangle wave, it should not be surprising that its magnitude spectrum is closely related to a $\text{sinc}^2(f)$ waveform (for those unfamiliar with Fourier transform pairs, there exists a common pair: $\Delta(t/\tau) \xleftrightarrow{\mathcal{F}} \tau \text{sinc}^2(\tau \cdot f)$). The waveform used to generate these frequency response plots is only an approximation of the actual glottal waveform; as such, the accuracy of the spectra in Figure 2.3 is dictated by the accuracy of this approximation. With that caveat, however, these plots still provide valuable insight into the time and frequency domain responses of the glottal waveform.

2.1.3 The Physics of Speech

The glottal waveform described in the previous section produces the pitch of voiced speech segments and the distinction between voiced and unvoiced segments of speech, but does not contain any linguistic information. This information is produced by the changes in shape of one or more part of the vocal tract.

The vocal tract can, most simply, be modeled as a tube with one open end and one closed end. Such a tube possesses several inherent resonant frequencies (frequencies at which acoustic sound will be amplified). A single tube of uniform cross-sectional diameter with a length equal to that of an average vocal tract - about seven inches - will have resonances at 500Hz, 1500Hz, 2500Hz, 3500Hz and 4500Hz [DP93]. When dealing with linguistics, these resonances are referred to as formants, and dictate how the speech signal will sound. As the vocal tract changes shape during speech, the resonant frequencies (and thus the formant frequencies) will change, altering the sound produced. An example of this would be to change the shape of the opening of the vocal tract, the lips, as shown in Figure 2.4.

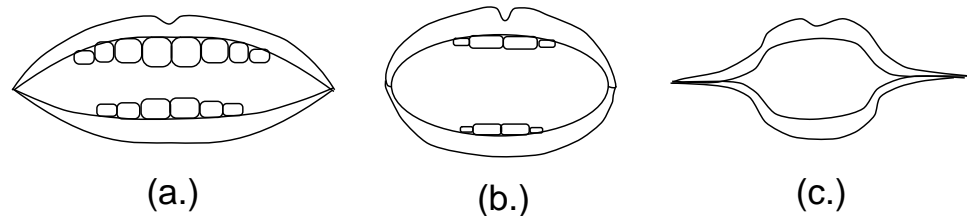

Figure 2.4: Shape of the lips for the phonemes /i/ (a), /æ/ (b), and /u/ (c).

In simple terms, the vocal tract, with its formant frequencies, can be thought of as a filter. The glottal waveform acts as the input to the filter, and the acoustic waveform produced at the lips is the output. The spectra of the glottal pulse, as

approximated in Figure 2.3, provide the pitch and certain other characteristics to the speech waveform, and the vocal tract shapes this waveform according to which sound is being produced. As such, one can change the sound produced from an /i/ sound to an /u/ sound without significantly affecting the glottal waveform, and vice-versa.

2.2 Glottal Waveform Sensors

Though it is possible to develop an approximation of the glottal waveform using the speech waveform and inverse filtering with a vocal tract transfer function estimate, for instance, it is desirable to measure the glottal function directly. There are a number of approaches to this problem, which can be grouped into three major classifications: *visual*, *mechanical*, and *electrical*.

One of the first examples of visual examination of the glottal function was Manuel Garcia's 1855 invention of the laryngoscope [Gar55]. Garcia held a small dental mirror at the back of his throat, and used a hand-mirror to reflect the sunlight so he could observe his own vocal folds during speech. Over time, Garcia's laryngoscope, intended primarily for his own research in the area of singing, was further developed and improved for medical research. In 1940, a Bell Labs camera was used for laryngeal cinematography, photographing the larynx at a rate of 4000 frames/s [Far40]. One disadvantage of these methods is that the devices are often uncomfortable for the subjects, and can only be used during sustained vowel production.

Two exceptions to this are the photoelectric glottogram first developed in 1960 by Sonesson [Son60] and later commercialized by Frøkær-Jensen [FJ67], and the

endofibroscope first presented in 1968 by Sawashima and Hirose [SH68]. Although both of these devices allowed for the study of the vocal organs during natural speech with less discomfort to the subject, they still possess a number of functional issues as described in [Hes83] and [Hoo97].

There are a variety of mechanical devices used to determine the glottal waveform. Some, like the vocal-tract extension tube described in [Son75], attempt to eliminate the effects of the vocal tract or lip radiation from the speech signal, leaving only the glottal waveform. Though similar to the inverse filtering technique mentioned previously, this method does not require knowledge of the vocal tract transfer function. Other mechanical devices work more like microphones. There are a number of microphones that use accelerometers to transduce vibrations in the body into an electrical signal. A throat microphone utilizes vibrations in the skin wall near the glottis as a measure of the glottal signal. One specific microphone that is of particular importance to this research is the Physiological Microphone (PMIC) described in Section 2.2.1.

The most common electrical devices for glottal waveform measurement act as transducers that relate impedance changes in the larynx to an electrical signal. Known as electroglottographs, these devices use the measured impedance changes to determine the state of the glottis (open or closed). The General Electromagnetic Movement Sensor (GEMS) produced by Aliph[‡] [Bur99], uses a focused antenna to register movement in human body tissue, most specifically in the head and neck areas where such vibrations are caused in general by speech production. One advantage of the GEMS sensor is that depending where the sensor is placed, one can control for the amount of phonetic information present in the signal — sub-glottal

placement will result in mostly just the glottal waveform, while cheek placement will include more speech information. However, the quality of the GEMS sensor signal is highly dependent on precise placement, regardless of the area of the head or neck on which it is used. One additional sensor designed at Worcester Polytechnic Institute, described in greater detail in Chapter 3, uses magnetic resonance imaging (MRI) concepts to measure changes to the relative dielectric constant of a cross-section of the larynx due to the opening and closing of the vocal folds. Because it measures an integrated effect over a cross-section of the neck rather than a specific location in the vocal tract, this sensor, known as the Tuned Electromagnetic Resonator Collar (TERC), attempts to eliminate some of the placement and subject stationarity issues of some of the other sensors.

2.2.1 The Physiological Microphone

The Physiological Microphone (PMIC), shown in Figure 2.5, was developed by Mike Scanlon at the Army Research Laboratory [Sca98]. The device is about one inch square in size, with a piezoelectric gel pad that is placed in contact with the skin during operation, typically either on the forehead or neck for speech applications. The device can be attached with a velcro strap, which makes it very easy to use. The concept behind the PMIC is that its piezoelectric pad couples better with the skin than with air, so that when tightly attached to the skin the device will pick up sounds from the body well but attenuate any surrounding environmental sounds.

Though not truly a non-acoustic sensor, since the device still picks up some air-coupled vibrations like a stereotypical microphone, the PMIC has significantly

[‡]Aliph, 8000 Marina Boulevard, Suite 120, Brisbane, CA 94005



Figure 2.5: The Physiological Microphone (PMIC).

better noise reduction than a microphone. This is especially true when the sensor is covered with an insulating material to further attenuate environmental sounds. The biomedical applications for the device are numerous in this respect (e.g. measuring the biological functions of firefighters (pulse rates, etc.) with a PMIC sensor attached to the inside of their helmet). Used in this method, the sensor can be noninvasive and effectively attenuate environmental noise, leaving only the desired signal. The functionality, ease of use, and relatively inexpensive cost of the PMIC make this device a desirable sensor for many speech processing applications, including this research.

2.3 Intelligibility Tests

When designing any kind of tests for a speech sensor, one of the difficulties is how to develop a consistent data set using human test subjects. One way to achieve this is by utilizing intelligibility tests. Intelligibility is a measure of how well speech can be understood by a human listener. Typically this measurement is used with regard to speech encoders or speech synthesizers (see, for instance, [PNG85]), but it can also provide valuable insight into a new sensor’s performance. There are a variety of established intelligibility tests, the majority of which can be classified into one of three categories: Word lists, sentence lists, or conversation.

A typical intelligibility test involves both a recording of the audio data (the “talker” stage) and a subsequent scoring of the data by a separate subject (the “listener” stage). For this research, however, only the talker stage will be executed, as the listener stage is beyond the scope of the research. The recordings from the talker stage will provide a structured data set from which to characterize the sensor, and at any point in the future the listener stage could be done using this data set, as a separate exercise from this research.

2.3.1 Word List Tests

In a typical Word List test, a talker will read from a list of individual words, and a listener will try to determine what word was spoken from the resulting recording (in the case of speech encoding, the recording will be processed before the listener hears it). There are two main classes of Word List tests: Open-set response tests and closed-set response tests. In an closed-set response test, the listener is provided

with a predefined number of possible words and must determine which one was spoken. In an open-set response test, the listener must determine the spoken word without the aid of such a predetermined list.

Open-Set Response Tests

When discussing linguistics and word lists, any English word can be broken up into parts so that it can be classified. For instance, the word “cat” consists of three phonemes: /k/, /æ/, and /t/. The initial and final phonemes are consonants, and the medial phoneme is a vowel, which means that “cat” would be classified as a Consonant-Vowel-Consonant (or CVC) word. Similarly, “do” would be classified as a CV word (/d/, /u/), “native” would be classified as a CVCVC word (/n/, /e/, /t/, /I/, /v/), and so on. Many of the Word List tests are comprised of CVC words for simplicity’s sake. In fact, one of the most basic tests is known simply as a “CVC Test.”

In this test, a talker reads a list of CVC words, typically within a carrier phrase such as “type the word ... now.” The carrier phrase is used so that a listener will know when the relevant word is going to be spoken, and to provide a sense of consistency. There are a number of issues with one particular set of these lists, used by Arcon Corporation[§] in their original corpus, namely that they are relatively short (20 words each) and that half of the words in each list are “nonsense words” with limited use in some intelligibility applications.

One particular set of CVC word lists that does not have these issues is the set of phonetically balanced word lists provided in [Ega48]. Each list consists of

[§]Arcon Corporation, 260 Bear Hill Road, Waltham, Massachusetts 02451

50 phonetically balanced (meaning the frequency of every phoneme in each list is roughly equivalent to that phoneme's frequency in the English language) words, for which the lists are known as PB-50 lists. All of the words in the list are actual words in the English language, though a few might be considered arcane by modern standards. The words that comprise the lists were extensively tested, and any of the proposed words that were either almost always or almost never correctly identified were eliminated from the final lists (since they would provide little to no intelligibility information either way) [Ega48]. The remaining words were divided so that each of the 20 lists was of equal difficulty. This means that the results of two tests using two different lists can be compared without worrying about which particular list was used.

One final open-set response test is a “sustained vowel list.” One specific set of these lists can be found in Table A.4. Each of the three lists consists of fourteen CVC words, such that each of the fourteen vowel phonemes of General American English is represented in the medial vowel of one of the words in each list. No carrier phrase is used for this test; rather, each word in the list is spoken individually, with the medial vowel sound sustained as consistently as possible for one to two seconds. These tests are useful for isolating the vowel sounds as opposed to the consonant sounds as a measure of intelligibility.

Closed-Set Response Tests

As mentioned previously, a listener in a closed-set response test has a limited number of possible choices when deciding what word was spoken. Typically, a closed-set test is used to judge the intelligibility of consonant phonemes. There are a variety of

styles of these tests. In an initial-consonant test, the talker will read one word from a set in which each word is identically pronounced with the exception of the initial consonant (e.g. [cat bat rat]). A final-consonant test would include sets of words where it is the final consonant phoneme that changes (e.g. [cat cap caʔ]). Similarly, in a medial-consonant test, it is the medial consonant phoneme that changes (e.g. [supper sucker suffer]).

The first closed-response test was designed by Grant Fairbanks in 1958 [Fai58]. His “Rhyme Test” is of the initial-consonant type, comprised of fifty sets of five words each. The talker chooses one of the five words from all fifty sets, and a listener later attempts to decide which word was spoken. The test was designed such that a listener would receive a list of word stems without their initial consonants (e.g. -ail), and must only fill in the correct consonant (e.g. *mail* or *sail*). The rate of occurrence of each English phoneme in the test was designed to be close to its frequency in the English language, and an attempt was made to ensure that all five words in a set were equally common. Fairbanks indicated a number of possible modifications to the test that could include a balanced number of voiced/voiceless initial consonants, etc.

In 1965, House et al [HWHK65] designed a Modified Rhyme Test (MRT) based on Fairbanks’ original Rhyme Test. The MRT is also an initial-consonant test, consisting of fifty sets of six words each. The major difference between the Rhyme Test and the MRT is that the MRT ignores how common each word is in the English language and is not phonetically balanced. The other major difference is on the listener side of the test. Rather than being provided with the word stem and filling in the missing consonant, which requires that the listener be trained to be

familiar with all possible responses, the listener is instead provided with each entire word set and simply circles or otherwise indicates which of the six words he or she hears. This means that the MRT is easier to administer, but does not provide any details about intelligibility for specific aspects of speech (voicing, frication, etc.).

The Diagnostic Rhyme Test (DRT), first developed in 1965 [VCM65], overcomes some of the shortcomings of a multiple-choice closed-set response test like the MRT. Having six possible responses as opposed to only two significantly decreases the possibility that the listener will identify the correct response purely by chance. However, it is very difficult to isolate specific types of intelligibility with a larger response set. It would be nearly impossible to design a set of six words such that the vowel and final consonant for all words were the same and the initial consonants differed by only one attribute (e.g. voiced vs. unvoiced). The DRT utilizes six intelligibility attributes:

Voicing - Phonemes with this attribute are produced by vibrating the vocal cords, such as /d/ or /b/. Phonemes without it are produced without vibration, such as /p/ or /t/. (*Dint vs. Tint*)

Nasality - Phonemes with this attribute are produced by “lowering the soft palate so that air resonates in the nasal cavities and passes out the nose,” [Edi00] such as /m/ or /n/. Phonemes without it are produced when air resonates in the oral cavity, such as /b/ or /d/. (*Nip vs. Dip*)

Sustention - Phonemes with this attribute are produced by only a partial closure of the vocal tract, allowing some air to pass through, such as /v/ or /ʃ/. Phonemes without it are produced by fully closing the vocal tract, such as

/p/ or /č/. (*Shaw vs. Chaw*)

Sibilance - Phonemes with this attribute will be fricatives or affricatives, such as /s/ or /ʃ/. Phonemes without it will not be affricated, such as /g/ or /k/.

(*Jaws vs. Gauze*)

Graveness - Phonemes with this attribute are produced at the periphery of the vocal tract (labial consonants) [Edi00], such as /p/ or /f/. Phonemes without it are produced in the middle of the vocal tract (alveolar and dental consonants), such as /θ/ or /t/. (*Pool vs. Tool*)

Compactness - Phonemes with this attribute are produced at the beginning of the vocal tract (velar and palatal consonants), such as /k/ or /j/. Phonemes without it are produced in the remainder of the vocal tract, such as /f/ or /θ/. (*Caught vs. Thought*)

One of the major advantages of the DRT is that its word list is balanced on a number of levels. For example, half of the words in the *sustension* list are voiced and half are unvoiced, and within each list are two word pairs from eight medial vowel phonemes. Thus, the researcher scoring the test can know the state of every word in the test for each of the six intelligibility attributes. Readers interested in a more detailed description of the DRT should read [Voi77]. As in the MRT, listeners are shown both words in each word pair, and simply indicate which of the two words they heard.

2.3.2 Sentence List Tests

The second main subsection of intelligibility tests is Sentence List tests. In the Word List tests the talker reads individual words, whether within a carrier phrase or alone, and a listener attempts to apprehend what word was spoken. In the Sentence List tests, the talker reads full sentences, and the listener tries to apprehend pre-selected portions of the sentences. Rather than individual word or consonant apprehension, Sentence List tests provide a different sort of intelligibility measure, and bring in the notion of contextual intelligibility. Researchers must be careful when interpreting the results of Sentence List tests, since talker rhythm, context, etc. can have a large impact on the scores [Ega48]. However, Word List tests provide very little information on intonation, stress patterns, and changing pitch, while Sentence List tests are quite useful in this respect. Three specific sentence lists are the Harvard Psychoacoustic Sentences, the Haskins Sentences, and the Semantically Unpredictable Sentences.

Harvard Psychoacoustic Sentences

The Harvard Psychoacoustic Sentences consist of a set of lists containing ten phonetically balanced sentences each, meaning they were chosen such that the rate of occurrence of phonemes in the English language is represented in their rate of occurrence in the lists. Talkers simply read through an entire set of sentences, and the listeners attempt to identify what was spoken, which means that little or no training is necessary. The full 72 sets of ten sentences each, provided by Arcon Corporation, can be found in Section A.1. One of the major advantages to the Harvard Sentences is the simplicity of their use and the fact that they are well known in the

linguistic community. However, there are also two large disadvantages to the test. Familiarity with the sentences can cause problems with listeners, as they may be able to fill in missing words to sentences they recognize even if they don't actually hear the specific words. Similarly, since the sentences themselves are all logical in form and content, listeners may be able to determine missing words from context [Lem99].

Haskins Sentences

The Haskins sentences are very similar to the Harvard Psychoacoustic Sentences, with one major distinction. The sentences that make up this test are logical in form (e.g. they follow typical English sentence structure like *subject-verb-object*), but not in content. An example of a Haskins sentence, taken from [Lem99], is “The short arm sent the cow.” The Haskins sentences have the same problem as the Harvard sentences with listener familiarity, but the illogical content of the sentences makes it very difficult to identify words solely from context.

Semantically Unpredictable Sentences

Finally, the Semantically Unpredictable Sentences, described in [Jek93], eliminate the problems of listener familiarity with the Harvard and Haskins Sentences. Rather than a fixed set of sentences, the sentences are generated from a list of words fitting a particular grammatical type (e.g. subject, verb, adverb, etc.). There are a variety of different sentence structures that are randomly used throughout the test (e.g. subject-verb-adverb, adverb-verb-object, etc.), so theoretically the test could be run a large number of times without ever repeating a sentence. Thus, listener familiarity

is much less problematic than with the previous two sentence tests, but the test itself is more difficult to administer. Readers interested in further information on Semantically Unpredictable Sentence tests are referred to [Jek93] and [Lem99].

2.3.3 Conversational Tests

The final subsection of intelligibility tests is the conversational test. Where Word List tests rate the apprehension of individual words, and Sentence List tests attempt to rate the apprehension of words in brief context, a conversational test tries to judge purely contextual apprehension. There are two ways to execute such a test. The first is to have a talker read a predefined paragraph about a particular topic and have the listeners try to determine the main idea of the paragraph. The second method is similar, but instead of the predefined paragraph, an actual conversation between the talker and a trained researcher is recorded. As such, a conversational test would not give much information about individual word apprehension or, for that matter, individual sentence apprehension. Rather, it attempts to rate how well the gist of the information can be understood without being concerned with the specifics.

2.4 Signal Processing Background

The intelligibility tests presented in the previous section provide a structured setup for audio recordings using human test subjects, but do not directly provide any type of characterization for an acoustic or non-acoustic sensor. In order to qualify and quantify the results from the recording sessions, a number of signal processing

techniques can be employed. Since the TERC sensor was originally designed as a non-acoustic glottal waveform sensor, meaning that it should theoretically not pick up any environmental noise, a good initial technique to employ is to find the signal-to-noise ratio (SNR) for the sensor in various noise environments. The hypothesis is that the SNR of the sensor should not change as the intensity of the background acoustic noise is varied.

2.4.1 Signal-to-Noise Ratio

The signal-to-noise ratio (SNR) is a power ratio of the desired signal versus the noise signal. In speech systems in particular, the SNR is a ration of the clean speech signal power versus the noise signal power. SNR is defined [Cou01] as

$$(SNR)_{dB} = 10 \cdot \log_{10} \left(\frac{P_{signal}}{P_{noise}} \right) \quad (2.1)$$

or

$$(SNR)_{dB} = 10 \cdot \log_{10} \left(\frac{\overline{s^2(t)}}{\overline{n^2(t)}} \right) \quad (2.2)$$

where $\overline{s^2(t)}$ is the variance of the clean speech signal (with no noise present) and $\overline{n^2(t)}$ is the variance of the noise signal (with no speech present). A typical application of the SNR measurement would be to digitally mix a clean speech signal with a noise signal to create a synthetic signal with a particular SNR. When running experiments with noise estimation in noisy speech signals, for instance, it is the general practice to create a synthetic noisy speech signal with a predefined noise signal in order to be able to determine how well a particular algorithm works at various SNR levels [YS02].

The difficulty, though, is that in these artificial experiments, the noisy speech

signal $x(t)$ is defined as

$$x(t) = s(t) + n(t),$$

such that the clean speech signal $s(t)$ and the noise signal $n(t)$ are explicitly known. In the case of recordings made in a real noise environment, a researcher has the noisy speech signal $x(t)$ and information about the noise signal $n(t)$ during sections of the recordings where no speech occurred. However, the clean speech signal $s(t)$ is not explicitly known. Computing the SNR of these noisy signals from (2.1) or (2.2) directly is therefore impossible. There are two possible alternatives in this case. The variance of $x(t)$ can be defined as

$$\begin{aligned} \overline{(s(t) + n(t))^2} &= \overline{s^2(t) + 2s(t)n(t) + n^2(t)} \\ &= \overline{s^2(t)} + \overline{2s(t)n(t)} + \overline{n^2(t)}, \end{aligned}$$

which, if $s(t)$ and $n(t)$ are zero mean and independent, can be rewritten as

$$\overline{s^2(t)} = \overline{(s(t) + n(t))^2} - \overline{n^2(t)}, \quad (2.3)$$

Therefore, since the two terms on the right-hand side of (2.3) can be explicitly calculated, (2.3) provides an expression for the variance of the clean speech signal. It is important to note, though, that (2.3) is dependent on the fact that $s(t)$ and $n(t)$ are independent, and so this technique will not always be valid.

A second technique involves developing an estimate of the clean speech signal through spectral subtraction (see, for instance, [Fan02] or [BK03]). If a sample of the noise signal from sections of the recording where no speech is present can be obtained, one can use spectral subtraction to develop an estimate of the clean speech signal from which to calculate the SNR using (2.2). The drawback to this method is that the speech signal used to calculate the SNR is only an estimate,

and as such the accuracy of the SNR measurement is limited by the accuracy of the speech estimate. This method does not rely on the assumptions of the previous technique, though, and so it can be used in any case where a sample of a stationary noise signal with no speech present can be obtained.

2.4.2 Pitch Detection and Tracking

Another measure of the efficacy of the TERC sensor in the recordings is how well it is able to detect the pitch of voiced segments of speech. The ability to track pitch during speech is a very important facet of many speech processing techniques. One particular instance that illustrates this nicely is one of the most difficult noise environments in speech processing, known as “cocktail party” noise [LM87]. One can imagine being in a party where several conversations are occurring simultaneously and attempting to focus in on only the desired conversation. The human ear is naturally very good at this type of filtering, but designing a computer algorithm to try to filter out “noise” and salvage the “speech” signal when the noise itself is speech is quite a difficult problem. If an algorithm were able to follow the pitch of a particular speaker, however, it would be easier to determine which speech segments are noise and which ones make up the desired signal.

There have been a number of methods defined to try to extrapolate the pitch of speech from a speech sample. Interested readers are referred to [Sch68] and [SR79] for a sample of these techniques. Two particular techniques are compared in [Mar82]. The first is known as the “cepstrum method,” in which a Fourier transform of the logarithmic power spectrum identifies periodicity in the speech signal. The second is known as “spectral comb correlation.” In this method, a signal is defined

such that its frequency-domain representation is a pulse train with harmonics at $f = k\omega_c$, for $k = 1, 2, \dots$. This “comb” signal is then correlated with the speech spectrum for various values of ω_c . The value of ω_c for which the correlation is a maximum (i.e. where the “teeth” of the comb waveform line up most closely with the peaks of the speech waveform) is then the estimate of the fundamental frequency of the speech.

One benefit to this method is that the range of frequencies at which humans are able to produce speech, referring specifically to the range of the fundamental frequency as opposed to the bandwidth of audible speech, is quite limited (refer to Section 2.1.2). Therefore, the range of frequencies through which ω_c must be swept, depending on the desired precision, is manageably small.

CHAPTER 3

TERC SENSOR SYSTEM DESIGN

As described in Chapter 1, there are several interconnected areas of focus for this research. The initial goal is to develop the necessary test apparatus and procedures to be able to collect real-time audio data from the Tuned Electromagnetic Resonator Collar (TERC) sensor under experimental conditions. Once the data is collected, the goal then shifts to analyzing the data in order to develop a characterization of the sensor's performance. The ability to realize any of these goals, though, is contingent upon the development of a system capable of acquiring a useful audio signal from the TERC sensor. Before such a system can be understood, however, one must first understand the underlying principles of the sensor's operation.

3.1 Principles of Operation

As discussed in Section 2.1.3, a hollow tube of a particular shape will have several natural resonant frequencies — frequencies at which acoustic waves passing through the tube will be amplified. Changing the shape of the tube will alter the tube's resonances, and thus the sound produced at its end. The vocal tract is one complex example of such a tube, where altering the shape of the tube (e.g. changing the shape of the lips as shown in Figure 2.4) will affect the acoustic sound emanating from the mouth. As a much simpler example, one can design a hollow cone with a small hole at one end and a large hole at the other such that when people speak or yell into the small end, an amplified version of their voice will emanate from the large end due to the tube's resonances.

In much the same way, one can design an electronic circuit with capacitive and inductive elements such that the circuit will resonate at a particular frequency. As with an acoustic resonance, any frequency content of signals near this resonant frequency will be amplified. Changing the capacitance of one of the elements in the circuit will shift the location and depth of this resonance. The TERC sensor was designed such that its load acts as a capacitive element in such a circuit. Changing the dielectric properties of its load will affect this capacitance and thus affect the natural resonance of the sensor.

If one considers the human neck in a highly simplified manner, it can be modeled as a cylinder of muscle when the vocal cords are fully closed. When the vocal cords are opened, this model changes to include a smaller cylinder of air representing the open glottis, as illustrated in Figure 3.1.

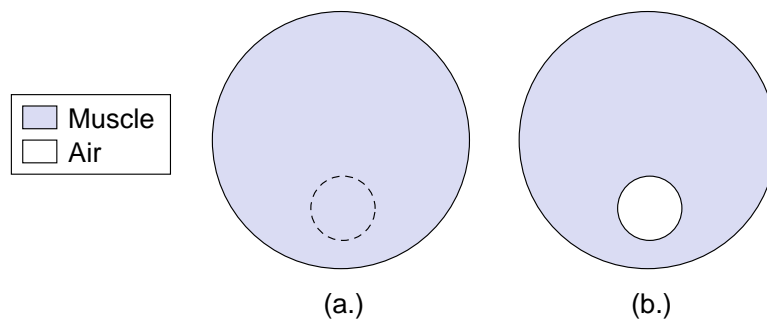

Figure 3.1: Simplified model of the neck with closed (a.) and open (b.) glottis.

This is a highly inaccurate model of the human neck, but is useful to demonstrate the theory governing the TERC’s design. The change in the state of the glottis (i.e. the opening of a tube of air) will alter the averaged dielectric properties of the neck. With the neck as the sensor’s load, therefore, these changes to the dielectric properties of the neck will cause shifts in the sensor’s resonance. As such, these

resonance shifts, illustrated in Figure 3.2, can be utilized as a proxy to measure the state of the glottis.

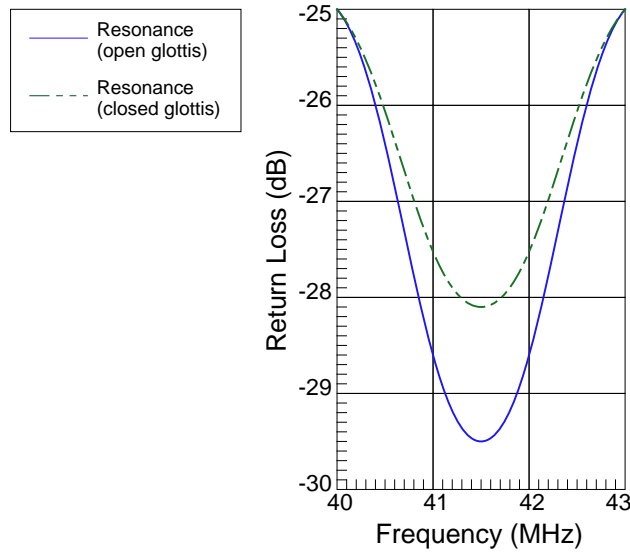

Figure 3.2: Theoretical resonance shift due to glottal state changes.

From preliminary laboratory experiments with the sensor, a typical resonant frequency is within the range of 35MHz to 60MHz, depending on the test subject. The problem, then, is how to transduce these high-frequency resonance shifts into a baseband electrical signal representing the glottal waveform. If the TERC sensor is driven with a sinusoidal signal at a frequency close to the sensor’s resonant frequency, shifts to the location and depth of the resonance will alter the level of amplification of the drive signal. The resulting signal, then, will be a sinusoid at a fixed frequency whose amplitude changes according to the state of the glottis. This is, in effect, an Amplitude Modulated (AM) signal with a carrier frequency, f_c , between 35MHz and 60MHz and an envelope, $m(t)$, whose frequency is the frequency at which the glottis is opening and closing. This resulting AM signal, $s(t)$, can be

defined as:

$$s(t) = A_c [k + m(t)] \cos(2\pi f_c t + \phi), \quad (3.1)$$

where A_c is the amplitude of the carrier signal, k is a constant offset for the envelope, and ϕ is a phase offset. Figure 3.3 illustrates the concept behind the production of this AM signal.

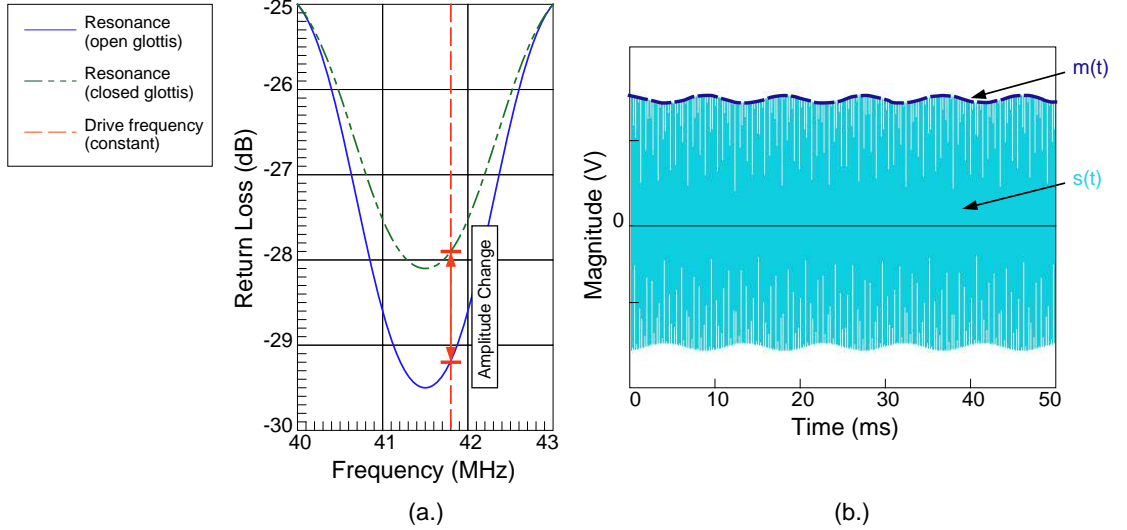

Figure 3.3: The changes to the resonance caused by the glottal cycle (a) result in an amplitude modulated voltage waveform (b).

3.2 TERC System Setup

Following an understanding of the theory behind the TERC sensor's operation, the next step was to develop a signal acquisition system that would be capable of outputting the audio signal $m(t)$ from (3.1) for subsequent recording. All of the testing and sensor characterization described in the remainder of this research was

dependent on this first step of acquiring a meaningful audio signal from the TERC sensor.

3.2.1 Network Analyzer Tests

The final TERC signal production system can be divided into two major components: the drive circuitry to provide the AM signal $s(t)$ defined in (3.1) and the demodulation circuitry to obtain the envelope $m(t)$ from this AM signal. The first piece of the drive circuitry is an RF carrier signal with a constant amplitude of -10dBm, produced with a Hewlett Packard 8647A signal generator. This value of -10dBm was chosen to allow for a strong enough signal from the TERC sensor while remaining well within the FCC safety regulations for radiation effects. A circulator [Wen91] makes it possible to measure the reflected signal from the TERC sensor (port 2) caused by the drive signal (port 1) with negligible interference between the input and output (port 3).

Before attempting to design the demodulation circuitry for the TERC sensor, it was important to test the existing components of the drive circuitry including the sensor itself. Such a series of tests not only verified the operation of each component, but also facilitated the development of more precise specifications for the demodulation system. These tests were conducted on a Network Analyzer capable of replicating the desired functionality of various portions of the drive and demodulation systems. The first test was of the TERC sensor itself, with the sensor attached directly to the Network Analyzer input port using an SMA cable. The Network Analyzer provided the -10dBm drive signal, manually tuned to the resonant frequency of the sensor with a human neck as its load. The Network

Analyzer measured the reflected signal from the TERC sensor, and displayed the resulting baseband signal when operated in Continuous Wave mode (producing a single drive frequency rather than a discrete sweep of frequencies). Figure 3.4 shows the resulting baseband signal during a period of voiced speech production.

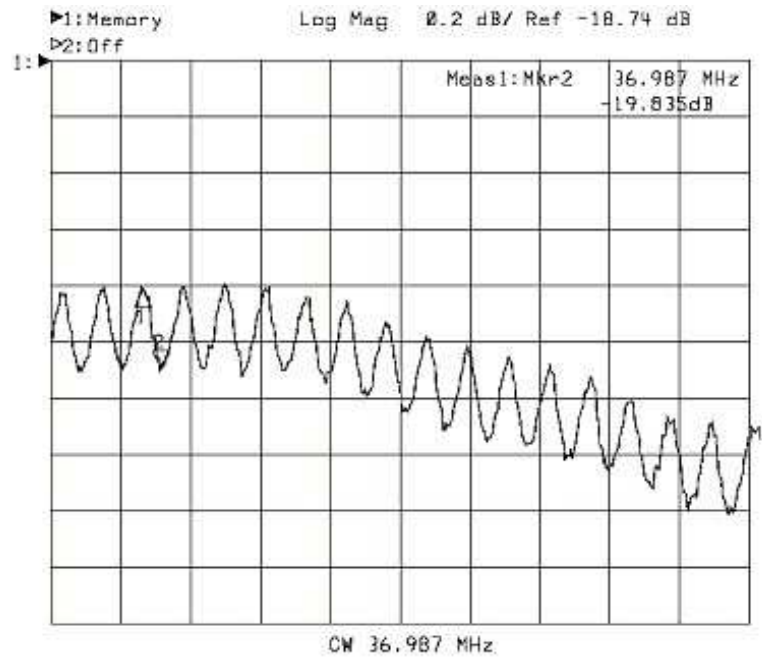

Figure 3.4: Baseband glottal signal from TERC sensor during voiced speech as seen on Network Analyzer [Pel04].

The periodic signal seen in Figure 3.4 is the baseband signal $m(t)$ defined in (3.1). This plot serves two purposes. The first is to verify that the TERC sensor itself functions as originally intended. A more in-depth description of this sensor validation can be found in [Pel04]. Because the Network Analyzer can demodulate the baseband glottal signal as shown in Figure 3.4, it is reasonable to expect that a separate demodulation circuit can be feasibly designed. The Network Analyzer signal also shows the amplitude of the AM signal $s(t)$ and its envelope $m(t)$, which

are important considerations when developing a demodulation system.

The modulation factor, or percentage of modulation for such an AM signal, is defined as

$$MF = \frac{A_{max} - A_{min}}{2A_c} \times 100, \quad (3.2)$$

where

$$A_{max} = \max \{A_c[k + m(t)]\}$$

$$A_{min} = \min \{A_c[k + m(t)]\}$$

From the waveform in Figure 3.4, a reasonable value for A_c is -20dB, with a variation of ± 0.3 dB during voiced speech. Using (3.2), these values yield a modulation factor of approximately $MF = 1.75\%$, which is very small even under controlled circumstances. This only serves to increase the difficulty of producing a clear baseband signal from the AM signal, as described in the following section.

After verifying the operation of the TERC sensor on the Network Analyzer, the next set of tests was to determine whether the circulator, described previously, functioned as expected. There were two tests used to this end. When functioning properly, the circulator should allow a signal from port 1 to pass, without attenuation, to port 3 when port 2 is left as an open circuit. When port 2 is terminated with a 50Ω terminator, on the other hand, the circulator should block the signal from passing from port 1 to port 3, attenuating the signal to a significant degree.

Figure 3.5 shows the forward transmission of a signal through the circulator over a frequency range of 1MHz to 60MHz when port 2 is open and terminated, respectively. Within the range of the TERC sensor's resonant frequency (35MHz to 60MHz), the circulator operates as expected, allowing nearly all of the signal to

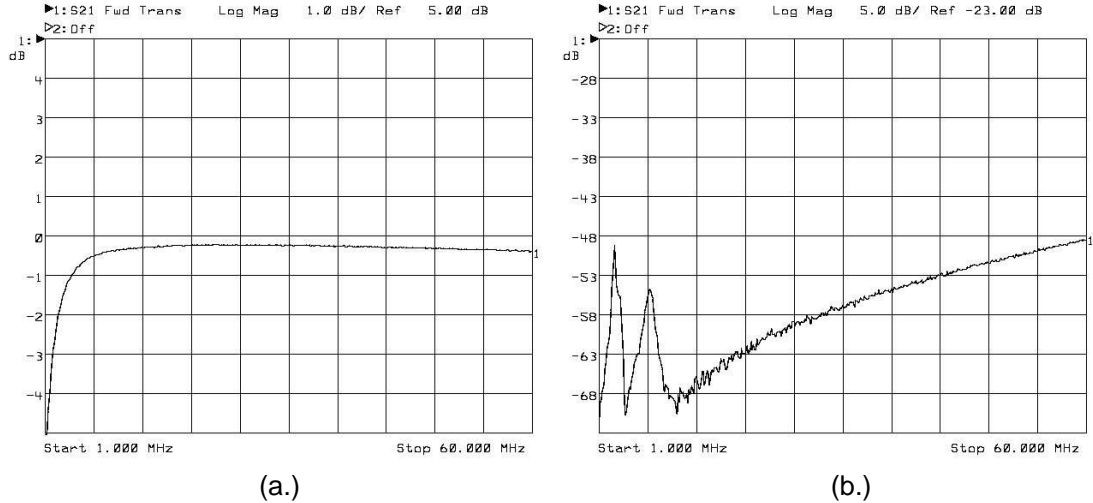

Figure 3.5: Forward transmission on Network Analyzer with circulator port 2 open (a.) and terminated (b.).

pass through with port 2 open and attenuating the signal by between 48dB and 60dB with port 2 terminated. Following the validation of the operation of the two major components of the drive circuitry, the next task was to develop the actual demodulation circuitry to be used during testing.

3.2.2 Demodulation System Design

As mentioned in the previous section, the AM signal from the TERC sensor that requires demodulation has a modulation factor of less than 2%. This adds a high level of difficulty to the process of designing a demodulation system. The simplest AM demodulation circuit is a diode/capacitor envelope detector, as shown in Figure 3.6.

There are two major issues that prohibit the use of such a circuit in this system. The first is the frequencies at which the TERC sensor operates. While an envelope detector can be designed in theory to operate up to high frequencies, the practical

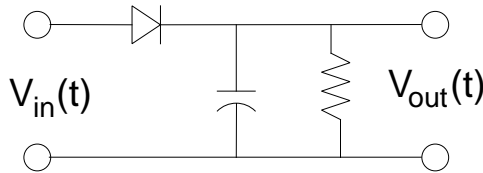

Figure 3.6: Diode/capacitor envelope detector circuit.

limitations of very small capacitor values (in the range of 5pF) dictate that any stray capacitance in the circuit would be very damaging to the circuit's functionality. The second issue is the small demodulation factor. Since the envelope detector works by following the envelope of the AM signal, the circuit will not work properly when the changes in the amplitude of the envelope are very small.

Another common demodulation circuit is a frequency mixer, which multiplies two sinusoidal signals to down-mix an AM signal to baseband. A mixer circuit is more appropriate than an envelope detector for the higher-frequency signals in the system, and in fact several such circuits were developed that could successfully demodulate an AM signal within the frequency range of the TERC sensor. However, the low modulation factor is still an issue with a mixer circuit, and none of the circuits designed were able to work properly for signals with such a small envelope.

After several semi-successful demodulation circuit designs, the decision was made to incorporate a commercial demodulation hardware/software package known as WinRadio into the system. Although the WinRadio package requires a computer for its operation, it is able to demodulate AM signals with very low amplitudes (less than -50dBm) and modulation factors down to 1%. The only major drawback to the WinRadio PCI card is that it can only demodulate signals with a carrier frequency of less than 30MHz. With this limitation in mind, the remainder of the

demodulation system could then be built around the WinRadio package and the drive circuitry described in the previous section.

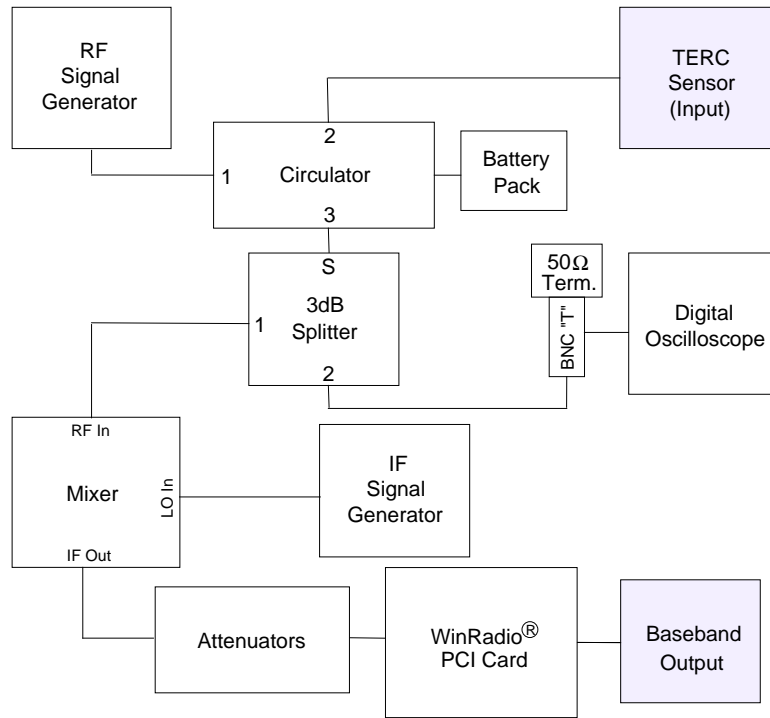

Figure 3.7: Signal Acquisition Setup for the TERC Sensor.

Since the proper operation of the TERC sensor is reliant on keeping the drive signal as close as possible to the sensor's resonant frequency, it is necessary to be able to monitor the signal at the output of the circulator to ensure that it is, in fact, operating in the resonance. This is accomplished by splitting the signal and passing one branch to a digital oscilloscope, matched to 50Ω with a terminator. Though certainly a crude method of monitoring the signal, one can alter the frequency of the carrier drive signal and watch the resulting changes to the amplitude of the signal as it moves in and out of resonance.

The second branch is passed on to the demodulation portion of the TERC sys-

tem, the major component of which is the WinRadio package described previously. The package is capable of demodulating various radio signals (AM, FM, DSB, etc.) and passing the resulting baseband signals out to the computer's sound card. However, since the device is only capable of demodulating RF signals up to 30MHz, an intermediate down-mixing stage was required in the system to bring the 35MHz - 60MHz carrier down into WinRadio's range.

An HP 8648D signal generator provides the constant amplitude (3dBm, as recommended for the Mini-Circuits ZX-05 mixer used for the IF down-mixing[†]) IF carrier signal. Since the WinRadio package will be providing a second down-mixing stage and its own filtering, no low-pass filtering is required at the IF down-mixing stage. The final piece of the system is an attenuation stage prior to the WinRadio PCI card input, intended to adjust the amplitude of the input signal to a more appropriate level for the software. The full TERC sensor signal acquisition setup can be seen in Figure 3.7.

[†]<http://www.mini-circuits.com/ZX05-SERIES.pdf>, last accessed 13 January 2004

DATA ACQUISITION SYSTEM DESIGN AND TEST PROCEDURES

Once a system was developed to produce baseband signals from the TERC sensor, the next challenge was to design an experimental setup and testing procedure to record meaningful audio signals from the TERC sensor, from which subsequent conclusions about its performance could be drawn. Before such a data acquisition system could be designed, however, it was first necessary to develop an understanding of how and why it would be used.

4.1 Context and Experimental Apparatus

One of the major goals of this research was to collect a large set of audio recordings from human test subjects wearing the TERC sensor, in order to be able to characterize its performance in a laboratory environment. The usefulness of results obtained using non-biological test fixtures or a Network Analyzer have strict limitations. Ultimately, the sensor's intended use is in a real-world environment with human users, and the true test of its performance is how it functions in such a setup. The difficulty with using human test subjects, though, is their unpredictability. In order to obtain a useful set of recordings leading to a structured corpus of data, the experiments must be well-designed to control for as many variables as possible under the circumstances.

The basic concept of the experiments was to test the TERC sensor in various acoustic environments, with the hypothesis being that its performance would remain consistent in all of the environments. In each environment, a human test subject

would read lists of words or sentences while wearing the TERC sensor to obtain recordings of the sensor’s signal during speech. To control for the level of noise during each recording session, the human subject was seated in a sound booth along with several sensors and sound-production devices. The background noise environments were produced through a pair of Alesis M1 ActiveTM biamplified reference studio monitors, positioned behind the subject at between neck- and head-height so as to put him or her in the center of the noise field. The dimensions of the sound booth and the location of the subject during the tests are shown in Figure 4.1.

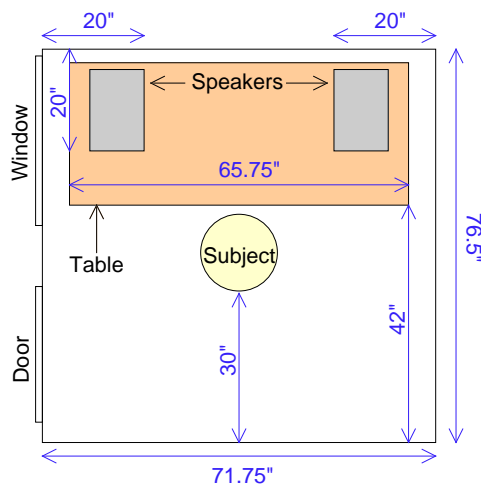

Figure 4.1: Interior layout of the sound booth during testing.

The analog signals from three sensors were digitized and recorded to develop the corpus. The first, and most important to this research, was WPI’s TERC sensor, described in Chapter 3. The TERC sensor was worn around the subject’s neck as close to the glottal region as possible (roughly behind the Adam’s apple on a male neck, as shown in Figure 4.2).

The second sensor was the Physiological Microphone (PMIC) described in Sec-

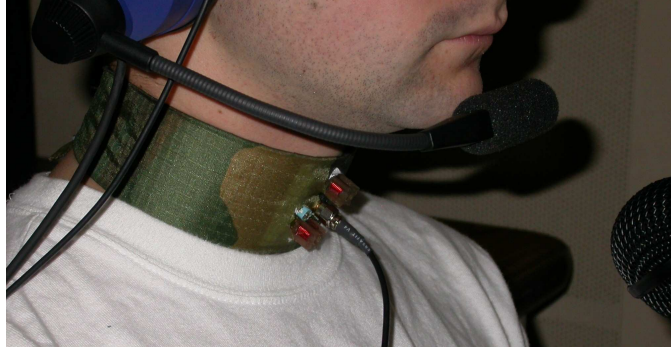

Figure 4.2: Physical location of the TERC sensor on a human subject's neck.

tion 2.2.1. Though this sensor was not developed at WPI, it is one of several speech sensors currently being studied in the DARPA/NAVSEA Advanced Speech Encoding (ASE) program through which this thesis was sponsored. In order to avoid interference with the TERC sensor, the PMIC was worn on the subject's forehead using a velcro strap during the recording sessions. In addition, although the PMIC was provided with a built-in preamplification circuit, the final recordings were conducted with this preamp circuit removed, as it tended to degrade or clip the signal to an unacceptable level during preliminary tests.

The final sensor was a Optimus 33-3021 Unidirectional Microphone placed near the subject's mouth as a resident microphone, also visible in the lower right corner of Figure 4.2. This microphone did not use any noise cancellation technology, and was used to pick up the sounds in the booth as the subject would hear them, with the exception that the subject's head provides an inherent acoustic shadow in front of the microphone. The purpose of the resident microphone was to provide a reference signal to which the other two sensors could be compared and which could be used as the noisy signal in subsequent signal processing applications.

Using the signals from all three sensors, a performance characterization of the TERC sensor could then be developed following the completion of the testing. The audio recordings could be analyzed to determine the TERC sensor’s signal-to-noise ratio (SNR), its capabilities for pitch detection, and its overall performance in comparison to the existing PMIC and resident microphone signals.

One additional experimental apparatus was used during the tests for safety reasons. The subjects wore a Sennheiser HME 100 passive noise noise cancellation aviation headset during each test, which provides 24dB of passive noise attenuation for hearing protection. The headset also has a boom microphone with noise cancellation technology, used in this setup to create a sidetone signal. In high-noise environments, there is a phenomenon known as the Lombard effect (see, for instance, [Jun93] or [CO96]) whereby a subject varies their speech volume to try to compensate for higher background noise. This effect can be detrimental to speech processing efforts, and so the purpose of using a sidetone signal is to allow the subjects to hear their own voice at the level at which they are speaking to mitigate the Lombard effect. This sidetone signal could also be patched outside the booth to the researcher’s headphones to allow him to follow along with the subject’s speech.

4.2 Sound Field Generation

An appropriate characterization of the TERC’s operation as a non-acoustic sensor required that it be tested in a number of acoustic environments. This entailed the development of a sound field generation system, as well as the policies and procedures that were involved with its use. All of the recordings were conducted in five different noise environments, which were selected based on the nature of

the research. Since the sensor was being developed through a DARPA grant for military applications, the noise environments were chosen to accurately reflect its intended use. The first environment was a quiet environment, used as a baseline for all other recordings. The speakers in the sound booth were completely turned off to avoid modifying the sound floor through any speaker static that might be present. The second environment (M2 High) was a recording made by Arcon Corporation in an M2 Bradley Fighting Vehicle. The third environment (M2 Low) was created digitally by attenuating the M2 High recording by 40dB (in reference to the dBc weighting). The fourth environment (Black Hawk High) was a recording made in a Sikorski UH-60 Black Hawk helicopter during flight, also recorded by Arcon Corp. The final environment (Black Hawk Low) was a separate recording made in a Black Hawk while it was not in flight, or “idling.” The second Black Hawk environment was used because it was attenuated close to 40dB from the Black Hawk High signal.

For each of the environments, Table 4.1 shows the original sound pressure level (SPL) readings made by Arcon Corp during the noise recordings in both dBa and dBc weightings where applicable. Also included are the actual SPL readings made in the sound booth prior to testing. There is a significant discrepancy between the original and actual measurements for the M2 Low environment. The speakers used during the testing were unable to accurately reproduce the 112dBa SPL originally intended for the M2 High environment without clipping. As such, the SPL for the M2 Low environment was lowered to maintain the original 40dB difference between the two environments.

Table 4.1: Noise Environments and Sound Pressure Level Readings

Environment	Arcon		WPI	
	SPL (dBa)	SPL (dBc)	SPL (dBa)	SPL (dBc)
Quiet	n/a	n/a	22	n/a
M2 Low	72	n/a	58	n/a
M2 High	112	n/a	98.5	n/a
Black Hawk Low	67	72	67	74
Black Hawk High	98	112	97	94

4.2.1 Sound Generation System

The background noise environments were produced on a desktop computer system, and the output signal from the computer was passed via a USB connection to a device known as the M-Audio Duo USB Audio Interface, which in this application functioned as a digital to analog converter. In order to amplify the signals to the correct levels before sending them to the speakers in the sound booth, the signals were first passed through a Behringer Eurorack UB502 mixing board. Though the mixing capabilities of the board were not utilized, it has sufficient preamplification capabilities to be useful in this system. The final amplified signal was then passed to the speakers in the sound booth during the testing. A block diagram for the full noise production system can be seen in Figure 4.3.

4.3 Recording System Setup

Once the sensors were selected and the sound generation system developed, the final system to be designed was the recording system. The data acquisition system described in Chapter 3, along with the resident microphone and PMIC, provide analog audio signals at their respective outputs. The goal, though, was to simultaneously

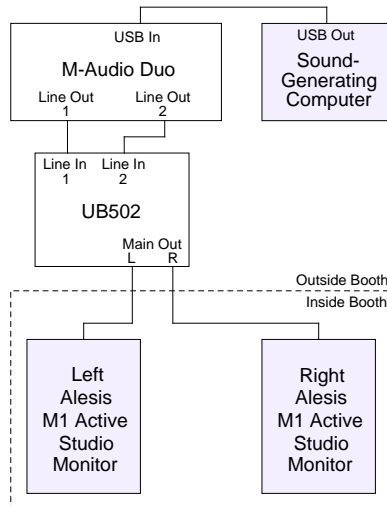

Figure 4.3: Environmental Noise Production System Setup.

record all three signals digitally for storage and subsequent signal processing applications. Preamplified versions of the analog signals from all three sensors were digitized using the M-Audio Quattro USB Audio Interface, which can record up to four separate 20-bit channels at a 48kHz sampling rate and patch them through a USB cable into a PC. The actual recordings were made using the Adobe Audition (formerly Cool Edit Pro) software due to its multi-track functionality. Although the program typically only allows stereo (two channel) recordings for audio devices, the M-Audio Quattro installs two drivers for its four input channels (one device driver for inputs 1 and 2, and another for inputs 3 and 4). Within Adobe Audition, the left and right channels of each of the two devices could be used to record a separate signal, thus providing the functionality of a four-channel recording device with software typically only capable of stereo recordings. Although using the full 20-bit capabilities of the Quattro would have provided better resolution and gain control in the input signals, compatibility issues between the Quattro hardware and Adobe

Audition software on a Windows platform necessitated the use of 16-bit recordings. Difficulties with 32-bit PCM (.wav) recordings in some versions of MATLAB, which would be used for much of the subsequent signal processing to the recorded signals, only served to further validate the decision to use the Quattro with this limitation.

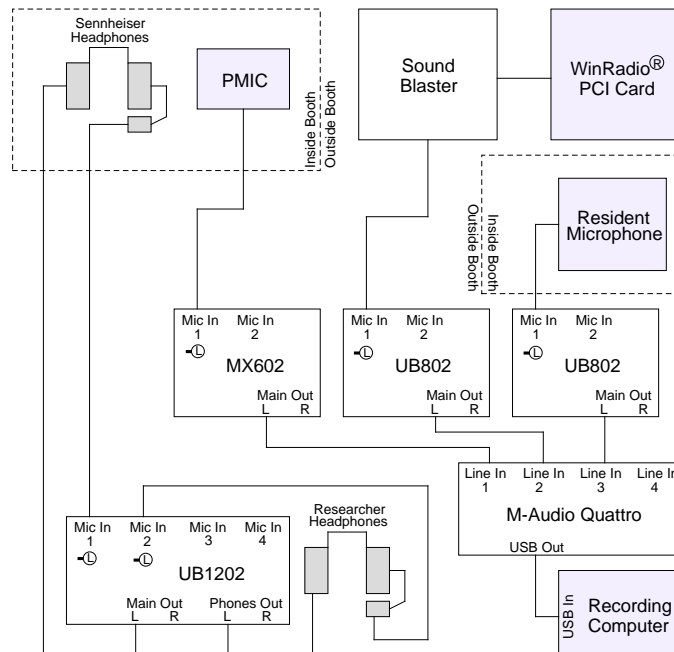

Figure 4.4: Recording System Setup.

The actual preamplification of the signals was accomplished using Behringer Eurorack UB802 and MX602 mixers, due to their mic inputs with 60dB input gain. Only one device was used for each sensor, though each device has multiple inputs with separate gain controls. In initial tests, approximately a -30dB L-R channel crosstalk was measured on the devices. Though this would be negligible in most normal audio applications, any significant crosstalk between two sensors' channels is unacceptable. If, for instance, there was any crosstalk at all between the resident microphone and the TERC sensor, any results for the TERC sensor could be at

best skewed or at worst unusable.

4.4 Testing Procedures

Once all of the systems were designed and operational, the final task was to determine exactly which tests would be executed during the recording sessions and to make any necessary final considerations regarding the use of human test subjects. Involved in this task was the selection of the subjects and approval for their use in the testing, the selection of the actual tests used during the recording sessions, and the time allotment for each test. Finally, since it is important to be aware of both the strengths and limitations of a test procedure before interpreting the results, a few of these limitations are briefly presented in Section 4.4.4.

4.4.1 Human Subject Considerations

Due to the scope of the project, including deadline constraints, only a small number of subjects could be included in the testing. Because there are significant differences between male and female speech, the most noticeable of which is the average pitch, it was important to include at least one male and one female test subject. Such a small data set makes it difficult to draw any strong conclusions about the results for either gender, but since the TERC sensor is still in the prototyping phase it is acceptable to create a data set where only generalized conclusions can be drawn. Including subjects of both genders will provide a larger range of results than only using male subjects.

Before any tests could be conducted with human test subjects, approval was first

obtained from the New England Institutional Review Board (NEIRB), an Association for the Accreditation of Human Research Protection Programs (AAHRPP) accredited independent organization in charge of approval for any human or animal testing done at institutions in Massachusetts. The approval was contingent upon strict guidelines to address any health hazards resulting from the testing. With the TERC sensor, there are only two relevant health concerns. The first is the radiation effects into the subjects' necks from the sensor, which are well below the FCC limits for the range of frequencies used during testing. The second is the noise levels during testing, since the subjects would be exposed to high-noise environments for extended periods of time. To obtain approval, the Sound Pressure Levels (SPL) of these noise environments and the duration of the exposure had to comply with the standards set forth by the Occupational Safety & Health Administration (OSHA).

The recordings were designed to be run in two sessions for each human subject. During the first two-hour session the subject was acquainted with the test procedure and the laboratory setup, given a chance to read and sign an informed consent document, and given an initial hearing test. The purpose of the hearing test, in conjunction with a second test given at the conclusion of all of the testing for each subject, was to identify any significant hearing loss due to the tests, in conjunction with OSHA standards. The actual recordings were conducted during the second session, broken up into five one-hour sections corresponding to the five noise environments defined in Section 4.2. Each of the one-hour sections allowed for a maximum of twenty-minutes of exposure time to each noise environment, with the remaining time allotted for system recalibrations and a break for the subject. The maximum exposure time of one hour and twenty minutes (twenty minutes for

each noise environment, excluding the quiet environment) accounted for less than 2% of OSHA’s daily recommended noise exposure. As such, no significant hearing loss was realistically expected due to the noise exposure in the tests.

4.4.2 Types of Tests Performed

As described in Section 2.3, there are a number of intelligibility tests to select from when designing the experimental procedures. The intention of these recordings was to provide as much relevant data as possible within the given testing constraints. In this instance, the strictest constraint was the time allotted for each recording session, which put limitations the number of intelligibility tests that could be performed. It is important at this juncture to recall that although typical intelligibility tests involve two sessions (the “talker” and “listener” portions of the test), this research was only concerned with the talker portion of the tests to develop a well-structured corpus of data for the subsequent signal processing applications.

Word Lists

The hypothesis that the TERC sensor would inherently measure very little supra-glottal information suggested the validity of including sustained vowel lists. The primary sound produced during each word of the vowel list is relatively constant, insomuch as the talker is able to produce a vowel sound without variation, and it is continuously voiced speech. While the varying phonation and pitch of word lists and sentence lists may provide valuable insight into the functionality of the sensor, the vowel lists should allow simpler characterization of the sensor under a more controlled environment.

As described in Section 2.3.1, the Modified Rhyme Test and the Diagnostic Rhyme Test are similar in many aspects, and it would be redundant to include both tests in the recording sessions. The time constraints mentioned previously necessitate the selection of one of the two tests over the other. The major advantage of the MRT is that its word sets are significantly larger than those of the DRT (six words per set as opposed to two). The small set size of the DRT dictates that a researcher be aware of the effect of chance in the results of the DRT, since a listener could correctly identify which word was spoken 50% of the time without even listening to the recordings. The major advantage of the DRT is that it is able to provide a great deal of intelligibility information easily. Since the list is broken up into six sections (voicing, nasality, etc. as described in Section 2.3.1), each of which includes the same number of occurrences of each vowel sound, any number of intelligibility scores (overall, nasality vs. voicing, one vowel sound vs. another, etc.) can be derived with ease. Since the intent of the recordings is to obtain the most amount of information possible about the TERC sensor, the reduced “chance factor” of the MRT is outweighed by the increased interpretability of the DRT.

The fact that both the MRT and DRT are closed-response set tests means that regardless of which test was used, a researcher would still need to be aware of the “chance factor” in the results. This is acceptable so long as the researcher is aware of it, but it also warrants the inclusion of an open-response set test along with the DRT. The PB-50 phonetically balanced word lists described in Section 2.3.1 are acceptable for this purpose. Two of the concerns with tests of this nature are that they be long enough to produce useful results (a longer data set results in improved statistical significance) and that the same lists are not repeated between different

talkers and environments. With fifty words per list and twenty lists, the PB-50 lists are adequately long to provide useful results and numerous enough to avoid repetition. Since the twenty lists were designed to be phonetically balanced and equally difficult, any of the full lists can be chosen at random for each talker and environment without affecting the results of the test. Although an open-response CVC test would provide very limited insight for intelligibility if the sensor cannot pick up supra-glottal information, it would be foolhardy to exclude the test solely based on this a priori assumption.

Sentence Lists

Finally, it is important to include a Sentence List test for two major reasons. First, all of the other tests only allow testing for the intelligibility of individual words or segments of words. A sentence test would allow for testing the intelligibility of full phrases rather than individual words or phonemes, which the TERC sensor will likely be unable to detect. The second reason for inclusion of a sentence test is that even if the TERC sensor is unable to provide intelligibility information for full sentences or words, people naturally tend to include different intonation, pitch, and emphasis while speaking full sentences. Regardless of the issue of intelligibility, a sentence test would therefore be able to provide a great deal of information about the TERC sensor's ability to detect pitch changes or other characteristics of speech. This fact is especially true in quiet environments, where the results for the TERC sensor can be directly compared to the results for the resident microphone signal. The question, then, is which particular sentence test to use.

The major drawback to the Harvard Psychoacoustic Sentences is that both the

content and structure of the sentences are predictable. A listener who can understand the majority of a particular sentence might be able to fill in the missing words due to context. In the specific case of the TERC sensor, the hypothesis is that it is unlikely that a listener would be able to correctly identify individual words, so it could be interesting to determine whether the sensor provides adequate information to identify words in context. In this respect, the major advantage of the Haskins Sentence tests could, in fact, be disadvantageous for the specific case of the TERC sensor. One additional advantage of selecting the Harvard Sentence Lists over the Haskins Sentence Lists is that the resulting data would more closely match the pilot corpus previously developed by Arcon Corporation. Although this factor is less important than those previously mentioned, continuity between the original corpus and that developed by this research certainly warrants consideration.

The fact that the Harvard Psychoacoustic Sentences are relatively well-known in the speech processing community can prove problematic. If listeners are familiar enough with the sentences that they can infer which sentence is being read without really understanding the words being spoken, it is possible that the results can become inaccurate. This is typically only the case, however, when the listener encounters the same sentences multiple times during a listening session. In the case of the TERC recording sessions, the inclusion of a limited number of talkers ensures that none of the sentences are repeated across talkers or environments, effectively invalidating this concern.

4.4.3 Recording Time

Once the final decisions were made on the intelligibility tests and the noise environments, it was necessary to determine how much time to allot to each specific test. Each test included a five second pause at the beginning and end of each recording, to both allow for editing of the raw recordings and to provide a sense of consistency. After the initial five second pause, the speaker identified himself or herself by reading an introductory statement including his or her subject number and the specific intelligibility test (e.g. “This is Subject M01 reading Vowel Word List #1,” etc.), followed by an additional five second pause. Each vowel word list included fourteen words, sustained for approximately one to two seconds each. Allowing for a total of four seconds for each word, the recording time for the sustained vowel word lists is reflected in Table 4.2.

Table 4.2: Recording Time for the Sustained Vowel Lists

Test Segment	Recording Time (MM:SS)
Initial Pause	00:05
Introductory Phrase	00:05
Pause	00:05
Word List	00:56
Final Pause	00:05
Total Recording Time	01:16

Each Harvard Sentence List contained ten sentences, and two lists were read for each noise environment for a total of twenty sentences. Both lists were recorded individually, with the initial and final pauses and introductory statements included for both. Allowing approximately four seconds for each sentence, the recording time for the Harvard Sentence Lists is reflected in Table 4.3.

Table 4.3: Recording Time for the Harvard Sentence Lists

Test Segment	Recording Time (MM:SS)
Initial Pause	00:05
Introductory Phrase	00:05
Pause	00:05
Sentence List 1	00:40
Final Pause	00:05
Initial Pause	00:05
Introductory Phrase	00:05
Pause	00:05
Sentence List 2	00:40
Final Pause	00:05
Total Recording Time	02:00

Each Diagnostic Rhyme Test consisted of four pages of 58 words each (including experimental words that were not scored), each of which was recorded separately. As defined in [Voi77], the words in the DRT are ideally read at a rate of 1.4 seconds per word. However, for these tests the words were read at a rate of 1.3 seconds per word to better coincide with Arcon’s original corpus. The recording time for the DRT is reflected in Table 4.4.

Each phonetically balanced CVC word list contained fifty words, which would be difficult for a talker to complete without making mistakes. For this reason, the lists were divided into two 25 word lists that would later be concatenated digitally. The initial list of 25 words, with the carrier phrase “Type the word . . . now,” included the initial and final pauses along with the introductory phrase. The introductory phrase was not included in the second list of 25 words, though, since the two would later be digitally combined into one full list. Allowing three seconds for each word and carrier phrase, the recording time for the PB-50 word

Table 4.4: Recording Time for the Diagnostic Rhyme Tests

Test Segment	Recording Time (MM:SS)
Initial Pause	00:05
Introductory Phrase	00:05
Pause	00:05
DRT Page 1	01:15.4
Final Pause	00:05
Initial Pause	00:05
Introductory Phrase	00:05
Pause	00:05
DRT Page 2	01:15.4
Final Pause	00:05
Initial Pause	00:05
Introductory Phrase	00:05
Pause	00:05
DRT Page 3	01:15.4
Final Pause	00:05
Initial Pause	00:05
Introductory Phrase	00:05
Pause	00:05
DRT Page 4	01:15.4
Final Pause	00:05
Total Recording Time	06:21.6

lists is reflected in Table 4.5.

The cumulative recording time for each noise environment, therefore, is reflected in Table 4.6. This leaves almost seven and a half minutes of time for any necessary equipment or sound-level tests while the noise environment is active and, more importantly, for any retakes necessary due to the inevitable subject and researcher mistakes that will occur during the recording sessions. This buffer time is a necessity since the tests are constrained by the absolute maximum of twenty minutes per day for each noise environment in accordance with the OSHA standards set forth in the

Table 4.5: Recording Time for the PB-50 Word Lists

Test Segment	Recording Time (MM:SS)
Initial Pause	00:05
Introductory Phrase	00:05
Pause	00:05
PB-50 1st Half	01:15
Final Pause	00:05
Initial Pause	00:05
PB-50 2nd Half	01:15
Final Pause	00:05
Total Recording Time	03:00

human testing approval.

Table 4.6: Total Recording Time for One Noise Environment

Intelligibility Test	Recording Time (MM:SS)
Vowel Word List	01:16
Harvard Sentence List	02:00
Diagnostic Rhyme Test	06:21.6
PB-50 Word List	03:00
Cumulative Recording Time	12:37.6

4.4.4 Limitations of Testing

The TERC sensor used for the testing is still in the prototyping phase of development, and as such there are still a number of inherent limitations, some of which directly impact the results of the testing. The most relevant of these is that the sensor in its current form does not account for shifts in the resonant frequency, requires tuning from subject to subject to be properly matched, and cannot be worn in its ideal location on the neck due to comfort issues. Although it is important

for the reader to be aware of these limitations when interpreting the results of the testing, they should not be viewed as “problems” with the sensor or its system, but rather as future research opportunities to continuously improve its design.

Resonance Tracking

In order for the sensor to function properly, it is necessary that it be driven with a signal at or very close to its resonant frequency. During a recording session, if the subject’s resonance moves significantly away from the frequency at which the system is driving the sensor, the glottal waveform signal at the output of the system will be, at best, degraded.

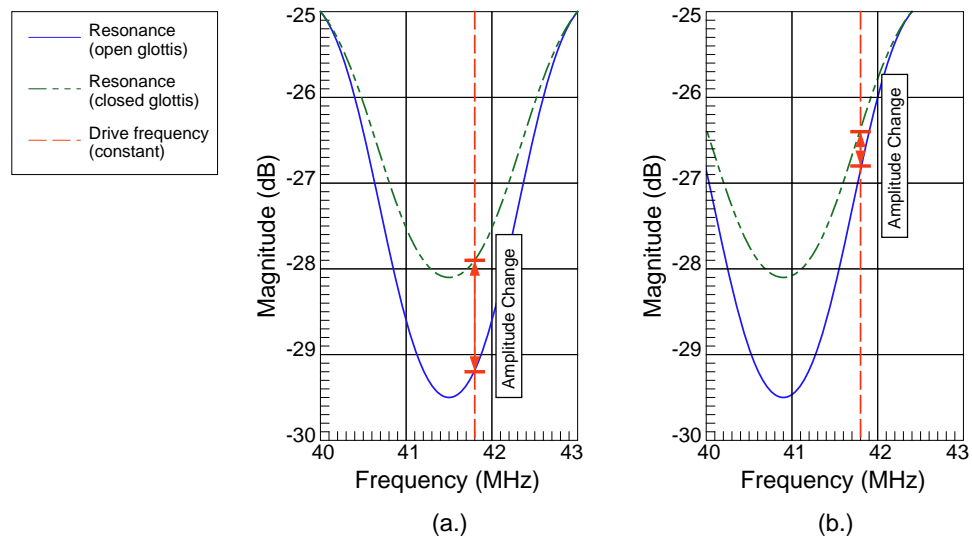

Figure 4.5: Concept behind using an AM system (a) and the effect of resonance shifts on the system (b).

This signal degradation is illustrated in Figure 4.5. During a testing session, consistency dictates that the system cannot be tuned or modified while the recording

is in progress. If the subject's resonance moves to any significant degree during the recording, the researcher must either accept the resulting signal with its inferior quality, or repeat the recording until it becomes acceptable. Since the majority of the tests utilized are relatively short (around a minute and a half or less), this limitation can be dealt with. However, a preferable and more permanent solution to this issue would be a resonance-tracking circuit. Such a circuit would eliminate the changes to the output signal quality resulting from large resonance shifts during testing.

Matching

The TERC sensor was designed with a matching network with variable components, so that it could be matched well to a 50Ω transmission line regardless of the subject wearing it. Matching the resonator's impedance to the rest of the circuitry in the system yields a much deeper resonance, and in return, a much more well-defined output signal. Once the sensor is correctly matched for a particular subject, it tended to remain relatively well-matched throughout a recording session. However, the sensor must be tuned prior to every session to ensure that it is properly matched to the particular subject, and if it shifted significantly during a recording session it was likely that it would become unmatched.

If the sensor were to be used in a real-life environment, it would be necessary to include some sort of automatic matching circuit similar to the automatic resonance-tracking circuitry described in Section 4.4.4. Like any piece of electronic equipment, it is acceptable for the sensor to require tuning or calibration on occasion. However, for any commercial or extended-use applications, it would be useful for the sensor

to be universal across any of its potential users.

Sensor Placement

Finally, there is a physical issue with the placement of the TERC sensor during testing. As described in Section 2.1.1, the vocal folds are located behind the thyroid cartilage, better known as the “Adam’s apple.” The ideal placement of the sensor, therefore, would be directly over the thyroid cartilage in order to pick up as much glottal information as possible. This is not a significant issue with a female test subject, as the thyroid cartilage is not well pronounced on the exterior of the neck in most females. For a male subject, however, the circuitry on the TERC sensor, when worn directly over the Adam’s apple, puts a significant amount of pressure on this sensitive location and can be uncomfortable to wear. Redesigning the sensor on flex circuitry could provide an easy solution to this limitation.

RESULTS AND CONCLUSIONS

Following the development of the test equipment and the execution of the experiments, it was then possible to draw final conclusions about the performance of the TERC sensor from the results of the recordings. Before discussing these conclusions, however, it is important to first present the results of the experimentation.

5.1 Results

The recordings from the experimental procedure described in Chapter 4 provided numerous results about the performance of the TERC sensor. Though the results for specific signal processing applications are both relevant and important, preliminary conclusions should first be drawn about the objective and subject performance of the sensor in general.

5.1.1 General Performance Results

Before delving into the objective results from the experiments, it is important to first discuss some of the more subjective results first, as an overview of the TERC sensor's performance. One of the objectives of these tests was to prove or disprove that the TERC sensor could accomplish its intended function with human test subjects — namely, that it could pick up some portion of the speech signal. The overwhelming answer to this question is that the sensor did function properly in the test environments. One demonstration of this is a comparison between the time-domain plots for the resident microphone and the TERC sensor in the quiet

environment. The segments of speech for both sensors were taken during the same period of sustained vowel production, although the signals were manually aligned in MATLAB to demonstrate the similarity in their periods. Figure 5.1 effectively illustrates that the TERC sensor picks up a signal related to the speech signal during periods of voiced speech, as was originally intended.

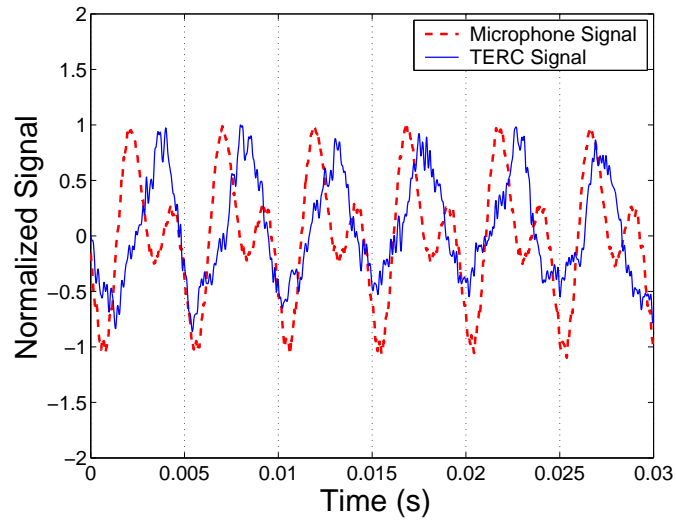

Figure 5.1: Time domain comparison between microphone and TERC signals.

It is also interesting to note that while the amplitudes of both signals were normalized to augment the visual comparison of Figure 5.1, the general shape of the TERC signal is not extremely different from the volume velocity waveform in Figure 2.2. This would seem to indicate that the actual signal from the TERC sensor is related to the expected glottal waveform signal.

The TERC sensor seems to only pick up voiced speech, with little or no articulation, in accordance with the initial hypotheses regarding its performance. Any higher frequency components of the TERC signal, if they exist, are well below the noise floor of the system. In some of the recordings, however, there appears to be

a low frequency component to the TERC waveform prior to the speech segment, as seen in Figure 5.2. This is likely due to low-frequency articulatory movements caused by an intake of breath prior to speech, or an opening of the throat prior to vocalization. However, since it does not occur in all of the recordings, it would be difficult to exploit this feature of the waveform consistently for any signal processing applications.

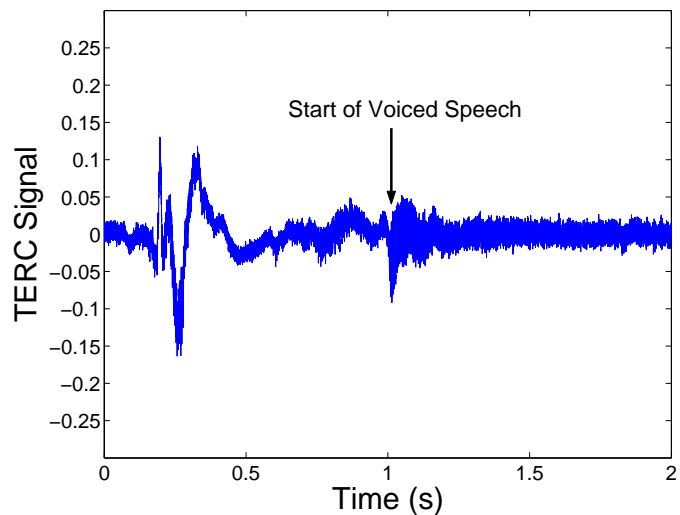

Figure 5.2: Low frequency signal content prior to voiced speech.

There was an audible delay between the recorded resident microphone and PMIC signals and the TERC signal. This delay is most easily seen in Figure 5.3, and is about 240ms between the start of voiced speech for the TERC and microphone signals.

Since the delay was most likely due to the longer signal path of the TERC signal (refer to Chapter 3 for a discussion of the TERC demodulation system), a test was run to determine the delay through the major component of this longer path, the WinRadio package. A test signal was split to a computer sound card and to the

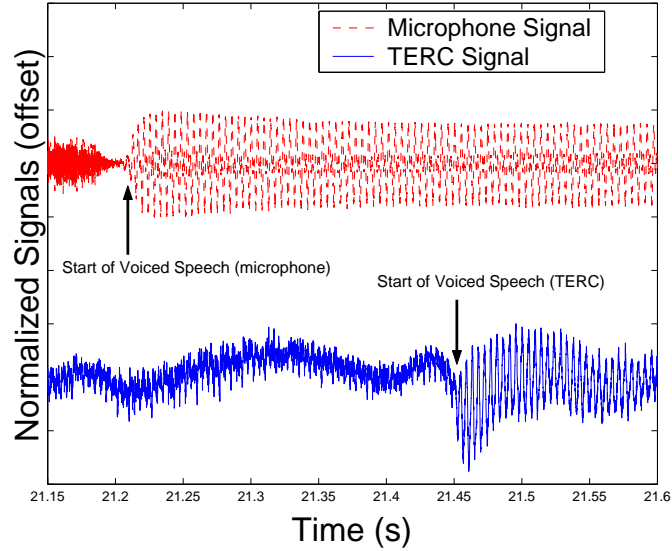

Figure 5.3: Delay between the TERC and microphone signals.

WinRadio PCI card, and the output of the WinRadio was passed to the computer as well, simultaneously recording both signals. The output was then shut off, and the delay between shut off times for both signals recorded. It is important to note that this was just a quick test with poor signal quality, but nevertheless the delay can easily be seen in Figure 5.4. From this plot, it can be seen that the majority of the delay, approximately 170ms, occurs in the WinRadio package, as expected.

Subjectively, even in the quiet environments there was a distinct background noise in the sensor signal that seemed to be fairly stationary. This was originally thought to be due to the electronic components of the system. One surprising aspect of the noise can be seen in the spectrogram in Figure 5.5, where there are apparent nulls at periodic frequency bands. Upon analysis, these nulls were present in every TERC sensor recording, at the same frequency bands in each recording.

After expensive experimentation, this was discovered to be an issue with a par-

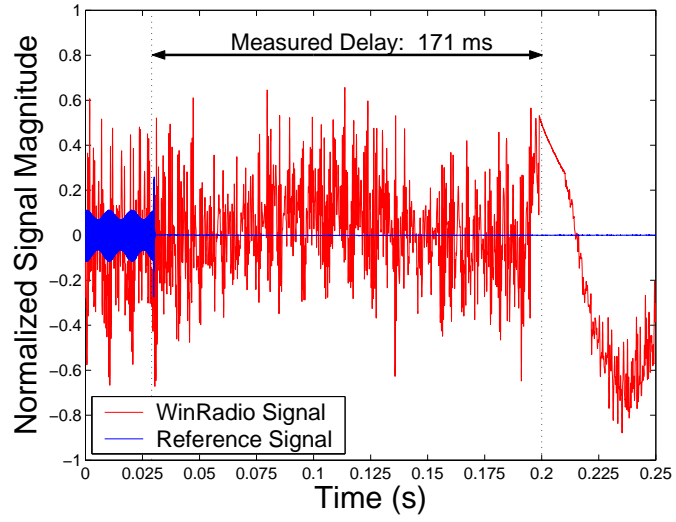

Figure 5.4: Delay through the WinRadio package after input signal turned off.

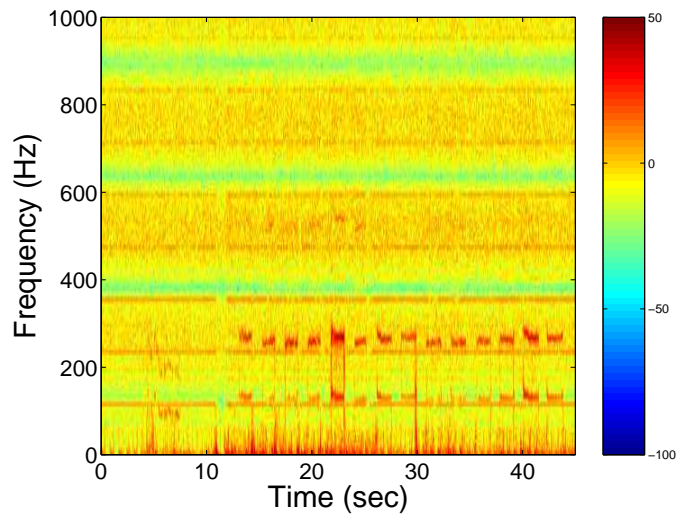

Figure 5.5: Nulls in background noise in spectrograms of TERC sensor.

ticular system component rather than with the TERC sensor. Although the issue was not discovered until after the recordings were made, it was preferable that the problem be one that is easily solved rather than one requiring a modification of the sensor itself. The WinRadio package utilizes the computer’s sound card for a portion of its downmixing stage. The SoundBlaster sound card in that particular computer has an audio setting in one of its menus called “spatial,” which adds an echoic sound to its output.

Figures 5.6 and 5.7 are spectrograms of a linear frequency sweep through the WinRadio with the “spatial” setting turned on and off, respectively. The same nulls from Figure 5.5 are present in Figure 5.6, but do not appear in Figure 5.7 where the “spatial” setting was turned off.

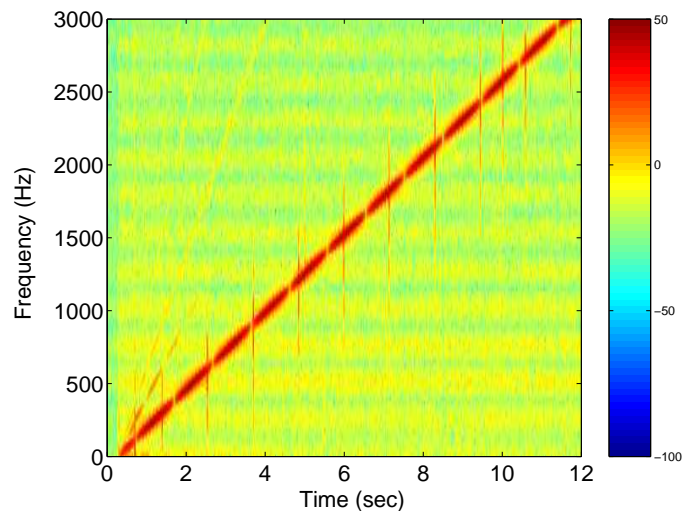

Figure 5.6: Spectrogram of linear frequency sweep with “spatial” setting on.

The effect of this setting can also be seen in a Power Spectral Density (PSD) plot of the two frequency-sweep signals from Figures 5.8 and 5.9. Figures 5.8 and 5.9 show these PSD plots with the “spatial” setting turned on and off, respectively. The

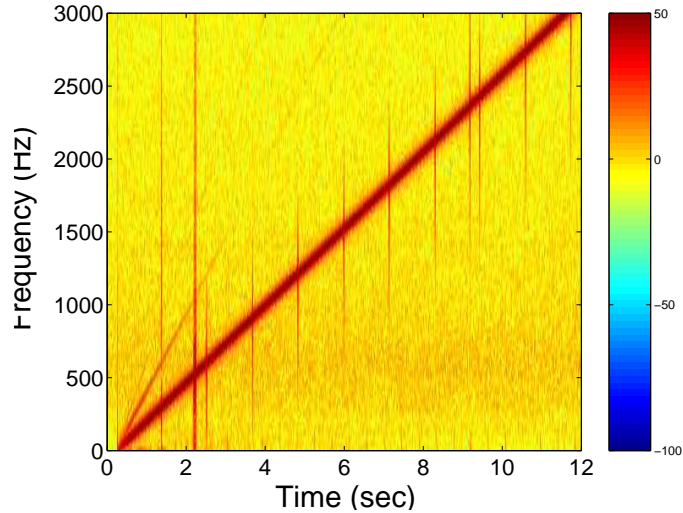

Figure 5.7: Spectrogram of linear frequency sweep with “spatial” setting off.

dips in the PSD in Figure 5.8 at the same locations as the nulls from the spectrogram in Figure 5.5 do not appear in the PSD in Figure 5.9 where the “spatial” setting was turned off.

In Figure 5.9, one can see a drop-off in the PSD of the TERC sensor at 7.5kHz. This cutoff frequency is easily explained when considering the operation of the WinRadio device. One of the settings in the WinRadio software is the IF bandwidth, since the WinRadio performs an initial IF downmix before the final baseband downmix. Changing the IF bandwidth has an audible effect on the final TERC signal, as certain parts of the noise are eliminated by lowering the bandwidth. This filtering could be just as easily accomplished in the post-processing stage, however, and the unnecessary loss of information when developing the raw data set is unacceptable. Though the initial hypothesis was that the TERC sensor would be unable to detect fricatives and other unvoiced speech, which occur at much higher frequencies than voiced speech, filtering out these high frequencies for the raw data set based on

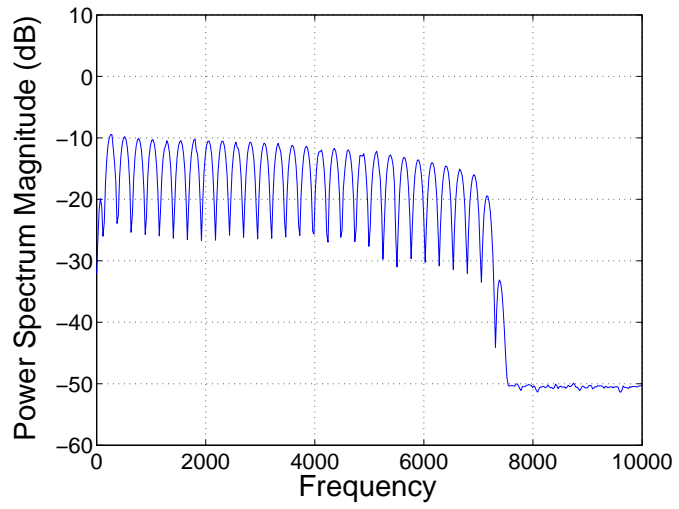

Figure 5.8: PSD of linear frequency sweep with “spatial” setting on.

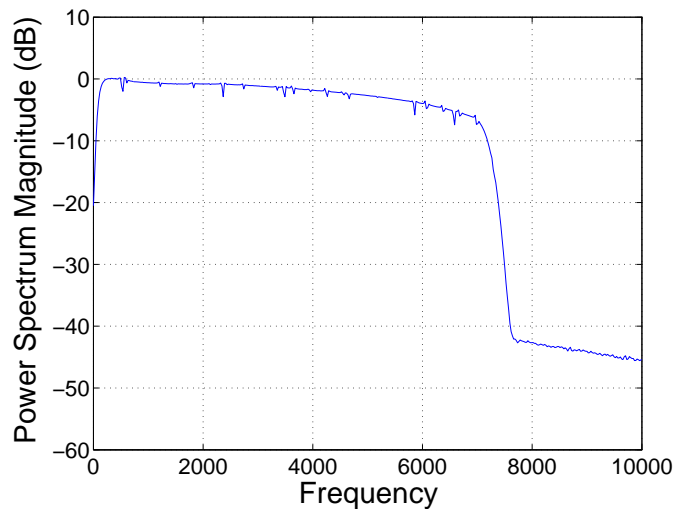

Figure 5.9: PSD of linear frequency sweep with “spatial” setting off.

these assumptions would be inappropriate. The IF bandwidth on the WinRadio, therefore, was set to its maximum value of 15kHz, which explains the sharp cutoff in the spectrogram at 7.5kHz.

5.1.2 SNR Results

The initial hypothesis about the TERC sensor was that it would be relatively impervious to the effects of environmental noise. An objective way to measure its performance in this regard is by taking a signal-to-noise ratio (SNR) measurement in each of the five noise environments. If the hypothesis holds, there should be relatively little change across the different noise environments. As described in Section 2.4, SNR calculations are difficult to make when one only has the noisy speech signal. Since we can clearly define segments of the recordings containing noise but no speech from the spectrograms and microphone recordings, both of the techniques defined in Section 2.4 could be employed.

The first technique involved the assumption that the noise and the speech were independent, which seemed to make sense after an initial consideration. The first set of SNR calculations seemed to produce reasonable results, with the SNR decreasing in the higher noise environments and the values being within a believable range. However, several of the calculations provided a negative variance for the speech signal, which is certainly not possible. The obvious conclusion was that this technique for calculating SNR was not valid for this particular system. A somewhat more unexpected corollary to this is that the speech and noise signals from the TERC sensor are correlated to some degree. If, in fact, the sensor is picking up some background noise through the body somehow, it would make sense that

changing the properties of the neck during speech would have an effect on the noise sensed in this manner.

In order to employ the second technique, the signals from each sensor for the vowel word list test in each environment were first de-noised using spectral subtraction (“noise reduction” in Adobe Audition). The resulting signal, with no additional signal processing or amplification, was used as the estimate of the clean speech signal. Using the inverse technique in Adobe Audition (“just noise” rather than “just signal” in the noise reduction properties) yielded a signal reflecting the estimate of the noise signal. This was done to ensure that the same segment of speech was used for both estimates. The variances of these two signals during a period of voiced speech during a sustained vowel list were used to calculate the SNR for each sensor using (2.2).

Because of the small number of subjects and data points, it is difficult to draw statistically significant results from the SNR measurements. In order to offset this somewhat, the definition of SNR from (2.2) was modified slightly to include an average SNR value over several samples:

$$(SNR_{AVG})_{dB} = 10 \cdot \log_{10} \left(\frac{\text{avg} \left(\overline{s_1^2(t)} + \overline{s_2^2(t)} + \dots \right)}{\text{avg} \left(\overline{n_1^2(t)} + \overline{n_2^2(t)} + \dots \right)} \right) \quad (5.1)$$

Five segments from each environment during the sustained vowel lists were used in (5.1) to calculate SNR values at each SPL level for all three sensors, as seen in Figure 5.10.

Figure 5.10 shows the results from all three sensors for the male subject. There are two important conclusions that can be drawn from these results. The first is that the SNR values for the resident microphone signal seem to be very realistic values,

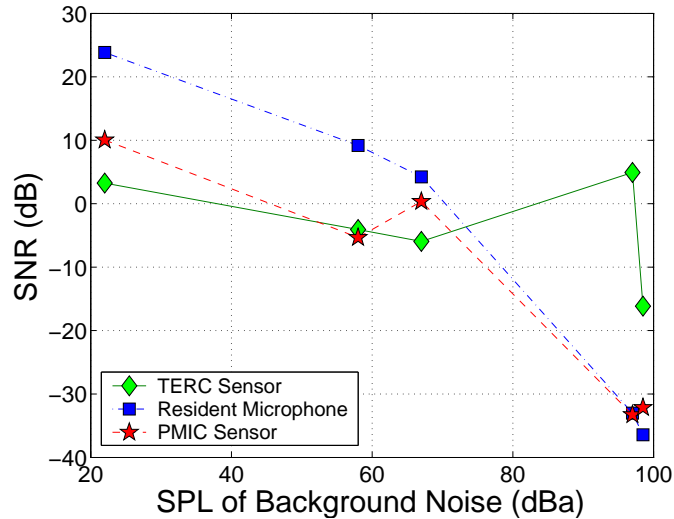

Figure 5.10: SNR versus SPL measurements for three sensors.

with a sharp descent as the SPL of the background noise increases. There is also approximately a 30 - 40dB drop from the two low-noise environments (M2 Low and Black Hawk Low) to the two high-noise environments (M2 High and Black Hawk High), which coincides with the 30- 40dB attenuation between the two recorded noise signals (refer to Section 4.2). The PMIC SNR values appear to decrease more slowly than the resident microphone values. An odd occurrence, though, is that the SNR values for the PMIC are consistent lower than those of the resident microphone. This is not completely unexpected, though, since the PMIC, when worn on the forehead as opposed to the neck, eliminates certain portions of the speech spectrum, which would significantly lower the SNR measurements. In addition, the resident microphone was placed close enough to the subject's head, which provided an acoustic shadow for the background noise, that higher SNR measurements would make sense.

The most interesting results are those for the TERC sensor. It is important

to first mention again the difficulty of drawing statistically significant conclusions about the SNR measurements with such a small data set. So while observations are still valid, they must be viewed with the understanding that they cannot be considered absolutely conclusive. It is also difficult to draw any conclusions from the SNR measurements due to the lack of consistency in the results. As described in Section 4.4.4, the necessity to retune and recalibrate the TERC sensor prior to each recording session precludes any true consistency in the results.

As a general observation from Figure 5.10, however, it appears that there may be a decline in the SNR values for the TERC sensor as the sound pressure levels increase, a direct contradiction to the original hypothesis that it would be impervious to acoustic noise. At the very least, though, the trend line for the TERC sensor across the SPL values is much shallower than for the other two sensors, which seems to indicate that it is much less sensitive to background noise than the microphone and PMIC.

The SNR values for the TERC sensor were generally lower than that of the other two sensors. While this is to be expected, given the inherent system noise described previously, this result is also somewhat misleading. As an arbitrary choice, the SNR measurements for the TERC sensor were done without cleaning the signals at all. The 15kHz IF bandwidth on the WinRadio package could be lowered without significantly affecting the TERC speech signal, or simple filtering techniques used to eliminate some of the system noise. These techniques would all legitimately improve the general SNR measurements of the TERC sensor, but the choice was made to use the raw recordings as the baseline. In other words, the values shown in Figure 5.10 can be considered a worst-case-scenario for the TERC sensor.

5.1.3 Pitch Detection

Based on the assumption that the TERC sensor is only capable of detecting voiced speech, one signal processing application for which it should be well-suited is pitch detection. One way to make an initial conclusion about whether this is possible with the actual results is to look at the output of the sensor in the frequency domain. If the fundamental frequency and subsequent harmonics are visible in the Fourier transform and the spectrogram, this would be an excellent indication that a pitch-detection scheme would work on the TERC signal. A comparison of the PSD of the microphone and TERC signals during voiced speech in the quiet environment is shown in Figure 5.11.

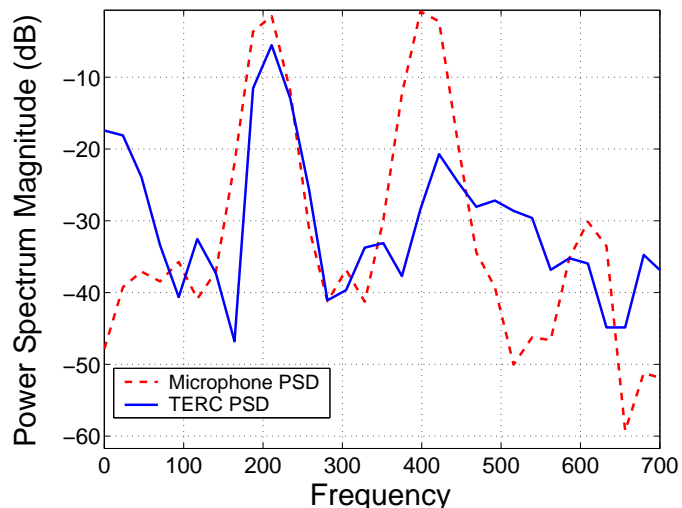

Figure 5.11: Comparison of PSD for microphone and TERC sensors.

The first two harmonics of the signal, at approximately 200Hz and 400Hz, are visible in the PSD plots for both sensors, and in fact the fundamental frequency (first harmonic) of both signals appear identical. This is a good indication that the pitch of the speech signal is present in the TERC signal. These signals were from

the female test subject during a sustained vowel list, and so a pitch of 200Hz is a very reasonable value.

Another method of visualizing the pitch components of the TERC signal is by using a spectrogram to see the frequency content over time. Figures 5.12, 5.13, and 5.14 are spectrograms of the vowel word lists, for the male subject in this case, in the Quiet, Black Hawk High, and M2 High noise environments.

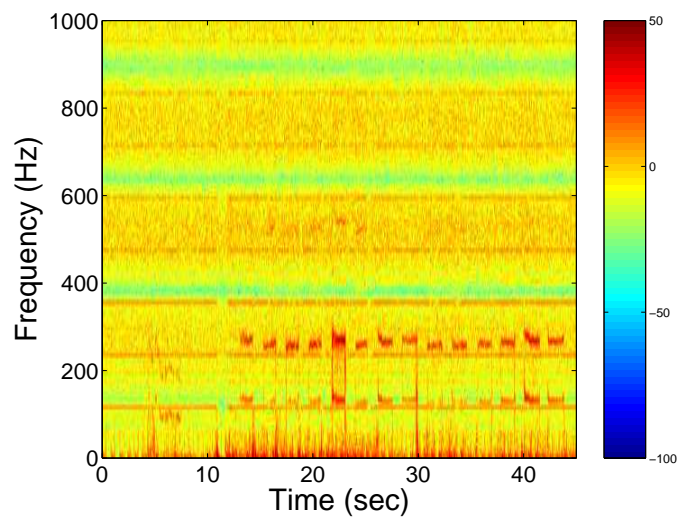

Figure 5.12: Spectrogram of male vowel word list in quiet environment.

In each of the three noise environments, one can clearly see the fourteen vowels spoken at regular intervals. For each vowel, the first two harmonics are visible in all three noise environments. The harmonics are more difficult to distinguish in the M2 High environment, since the background noise is more intense, but they are still visually apparent. In the Black Hawk High environment in particular, several harmonics in addition to the first two are apparent. In each case, any change in the location of the first harmonic over time (i.e. pitch changes) is reflected in each of the visible harmonics as well. The reason for the improved signal in

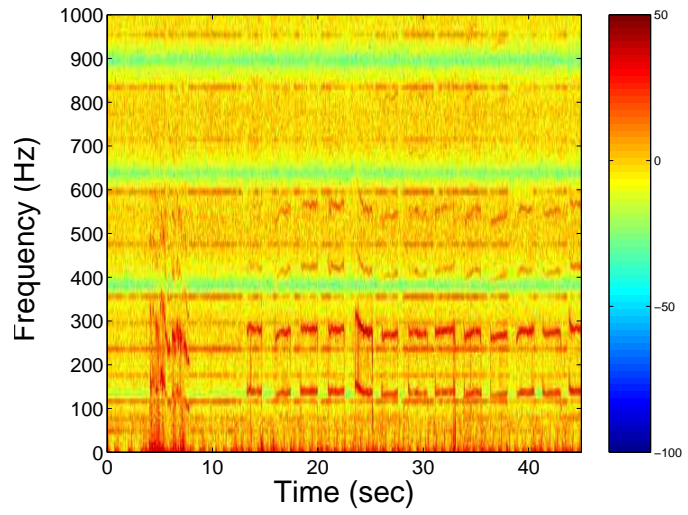

Figure 5.13: Spectrogram of male vowel word list in Black Hawk High environment.

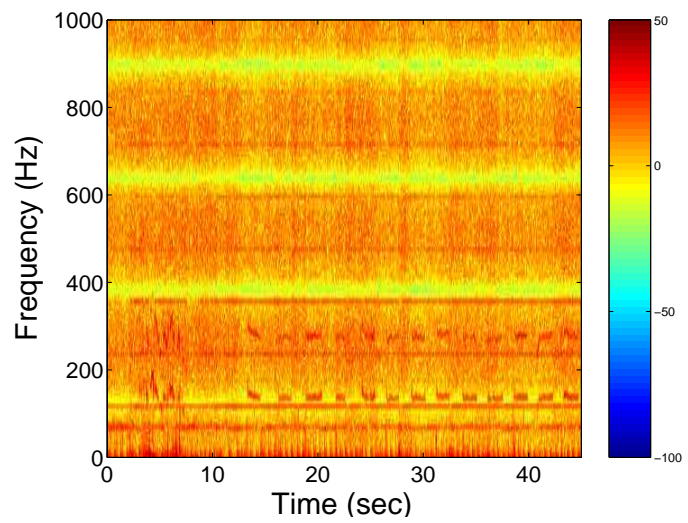

Figure 5.14: Spectrogram of male vowel word list in M2 High environment.

the Black Hawk High environment is very likely one of two possibilities. Either the sensor placement and tightness was exceptionally good for that particular recording, the subject was speaking significantly more loudly during the recording, or there was some combination of the two. Though more consistent results would certainly be preferable to make any final conclusions, even the skewed results are useful in showing what the sensor is ultimately capable of in terms of pitch detection when under optimum conditions.

There are two additional visual indications that the TERC sensor signal can be used successfully with pitch detection algorithms. This is the location of the fundamental frequency in the spectrograms. In each case, the fundamental frequency for the male subject falls within the range of around 110Hz and 150Hz, which are right in the average range for a male. The second indication is that for each fundamental frequency, the second harmonic occurs at twice the frequency of the fundamental, which is an excellent indication that these are indeed harmonics representing the pitch of the signal.

One of the problems with the signal, as apparent in the spectrograms, is that there is a fairly consistent 120Hz noise, with resulting harmonics. A simple filter in post-processing could eliminate this periodic noise, but this would cause additional problems. 120Hz is a perfectly reasonable value for male speech, and filtering out this component of the signal would likely destroy all or part of certain male's speech in the sensor signal. However, with the 120Hz noise and its harmonics still present in the signal, it is completely possible that a pitch detector would identify 120Hz as the pitch of the speech when in fact it may be higher or lower. Since this 120Hz noise is almost certainly due to the electronic components of the system, any future

evolutions of the sensor should be designed such that this noise is no longer present in the final signal.

Due to time constraints, it was not possible to attempt the “Spectral Comb Correlation” technique described in Section 2.4.2, but from the spectrograms shown in this section, it appears that it could be a very effective technique. Since in the majority of the TERC signals only the first two harmonics are apparent, the comb technique could be simplified to only include two harmonics as well.

5.2 Conclusions

After reviewing and analyzing the results presented in the previous sections, there are a number of important conclusions that can be drawn about the performance of the TERC sensor and the contributions of this research. Included in this section are these conclusions, as well as recommendations for future research based on the findings from these results.

5.2.1 Contributions of Research

At the conclusion of this process, it is important to summarize the contributions and deliverables of the research, both to define the ultimate framework of the research and to lay the groundwork for future experiments.

Prior to this research, no experimentation had been performed to prove or characterize the operation of the TERC sensor under experimental conditions. Though it had been possible to run preliminary tests using a Network Analyzer, the requirement of using an extremely expensive and cumbersome piece of equipment for the

testing precluded this method as a complete test of its intended purpose.

Over the course of this research, a number of systems were designed and tested that led to the final recordings of the TERC sensor. The first was the demodulation system that provided analog audio signals from the TERC sensor during speech. Though the system can certainly be improved for future experiments, its development provided the ability to execute all of the other research presented in this document.

The next deliverables were the sound generation and recording systems used during the testing sessions. Although these systems are by no means complex, subtle changes to the hardware and software can produce dramatic changes to the recordings, as with the effects of the “spatial” SoundCard setting shown in Figure 5.6. When reproducing these systems for future experimentations, one should be particularly aware of the cables used to connect the various pieces of equipment, as even the simple switch from a mono to stereo cable will seriously affect the signal quality.

The final deliverable was the data set collected during the testing, which is known as the WPI Pilot Corpus and is contained in Appendix B. With roughly two and a half hours of recordings for all three sensors, the WPI Pilot Corpus could easily be used in extensions to this research with more signal processing-focused applications.

Finally, the results and conclusions presented in this document provide both a proof of concept for the TERC sensor’s operation and a characterization of its performance, neither of which were previously available. These conclusions can be used to modify the sensor and the testing procedures to improve the performance

of future evolutions of the TERC sensor.

5.2.2 Performance and Recommendations

An important conclusion, both in light of and in spite of the results presented in Section 5.1, is that the initial prototype of the TERC sensor tested in these experiments does actually function as intended. In each of the five noise environments, with volunteer human subjects, the sensor produced an audible signal that is directly related to the signal produced by the resident microphone. It is necessary to point out that regardless of any conclusions characterizing the *level* of performance of the sensor, it does in fact perform its intended task.

The TERC sensor performs much as expected, recording a speech signal with very little articulation but ample pitch information. In general, the sensor records a strong signal component for the first two harmonics of speech. The strength of these harmonics compared to the noise in the TERC signals would indicate that it might be appropriate to use the sensor in voice activity detection applications. The sensor functions correctly with subjects of both genders, though significant tuning is required when switching between the two.

As opposed to initial assumptions, it is not clear that the TERC sensor is unaffected by acoustic background noise. The SNR plots in Figure 5.10 indicate a performance degradation as the SPL of the background noise increased. Though the TERC sensor is certainly less acoustically-coupled than a microphone or the PMIC, the expected conclusion that it is completely impervious to background noise cannot be definitively made.

There is a significant amount of system noise in the TERC signal, which has a

tend to audibly mask the speech signal to a certain degree. Although the recordings were intentionally made using the raw TERC signal with no signal processing, the signals could easily be cleaned up significantly with simple filtering functions. In addition, these filters could be added to the front-end circuitry of the system in future designs to preclude the necessity of performing the function during post-processing. It is important to note that while the sensor performs much as expected, its performance could be greatly improved even without serious changes to the system.

Limitations to the front-end circuitry of the sensor, including the lack of an automatic resonance-tracking circuit and proper demodulation circuit, limit the extent to which the TERC sensor itself can be characterized. In order to definitively characterize the performance of the sensor without the interference of the limitations defined in Section 4.4.4, significant modifications to the system would be necessary.

One simple modification to the sensor itself would be to redesign the sensor on flex circuitry, which would eliminate most of the placement and comfort issues defined in Section 4.4.4. The inclusion of a resonance-tracking circuit to the front-end of the sensor would eliminate the need to tune the sensor for each subject and between each recording session.

The sensor's performance on a Network Analyzer indicates that the majority of the focus for future research should be on the system circuitry rather than the TERC sensor itself. Two excellent research opportunities would be to eliminate the need for the WinRadio package in the demodulation system and to combine all of the front-end and back-end circuitry into one portable battery-powered system. This would facilitate in any future experimentation with the sensor, but would also

provide a large step towards the goal of commercializing the TERC sensor.

Although the TERC sensor in its current form could not realistically be used outside of a laboratory setting, the results of the experimentation indicate that a commercial application of the sensor is not outside the realm of possibility. The results and conclusions of this research should be used as a starting point toward that ultimate goal.

APPENDIX A

SPEECH INTELLIGIBILITY TESTS

A.1 Harvard Psychoacoustic Sentence Lists

Harvard Sentence List #1[†]

The birch canoe slid on the smooth planks
Glue the sheet to the dark blue background
It's easy to tell the depth of a well
These days a chicken leg is a rare disk
Rice is often served in round bowls
The juice of lemons makes fine punch
The box was thrown beside the parked truck
The hogs were fed chopped corn and garbage
Four hours of steady work faced us
A large size in stockings is hard to sell

Harvard Sentence List #3

The small pup gnawed a hole in the sock
The fish twisted and turned on the bent hook
Press the pants and sew a button on the vest
The swan dive was far short of perfect
The beauty of the view stunned the young boy
Two blue fish swam in the tank
Her purse was full of useless trash
The colt reared and threw the tall rider
It snowed, rained, and hailed the same morning
Read verse out loud for pleasure

Harvard Sentence List #5

A king ruled the state in the early days
The ship was torn apart on the sharp reef
Sickness kept him home the third week
The wide road shimmered in the hot sun
The lazy cow lay in the cool grass
Lift the square stone over the fence
The rope will bind the seven books at once
Hop over the fence and plunge in
The friendly gang left the drug store
Mesh wire keeps chicks inside

Harvard Sentence List #7

We talked of the side show in the circus
Use a pencil to write the first draft
He ran half way to the hardware store
The clock struck to mark the third period
A small creek cut across the field
Cars and busses stalled in snow drifts
The set of china hit the floor with a crash
This is a grand season for hikes on the road
The dune rose from the edge of the water
Those words were the cue for the actor to leave

Harvard Sentence List #2

The boy was there when the sun rose
A rod is used to catch pink salmon
The source of the huge river is the clear spring
Kick the ball straight and follow through
Help the woman get back to her feet
A pot of tea helps to pass the evening
Smokey fires lack flame and heat
The soft cushion broke the man's fall
The salt breeze came across from the sea
The girl at the booth sold fifty bonds

Harvard Sentence List #4

Hoist the load to your left shoulder
Take the winding path to reach the lake
Note closely the size of the gas tank
Wipe the grease off his dirty face
Mend the coat before you go out
The wrist was badly strained and hung limp
The stray cat gave birth to kittens
The young girl gave no clear response
The meal was cooked before the bell rang
What a joy there is in living

Harvard Sentence List #6

The frosty air passed through the coat
The crooked maze failed to fool the mouse
Adding fast leads to wrong sums
The show was a flop from the very start
A saw is a tool used for making boards
The wagon moved on well oiled wheels
March the soldiers past the next hill
A cup of sugar makes sweet fudge
Place a rosebush near the porch steps
Both lost their lives in the raging storm

Harvard Sentence List #8

A yacht slid around the point into the bay
The two met while playing on the sand
The ink stain dried on the finished page
The walled town was seized without a fight
The lease ran out in sixteen weeks
A tame squirrel makes a nice pet
The horn of the car woke the sleeping cop
The heart beat strongly and with firm strokes
The pearl was worn in a thin silver ring
The fruit peel was cut in thick slices

[†]Harvard Sentence Lists provided courtesy of ARCON Corporation

Harvard Sentence List #9

The navy attacked the big task force
See the cat glaring at the scared mouse
There are more than two factors here
The hat brim was wide and too droopy
The lawyer tried to lose his case
The grass curled around the fence post
Cut the pie into large parts
Men strive but seldom get rich
Always close the barn door tight
He lay prone and hardly moved a limb

Harvard Sentence List #11

Oak is strong and also gives shade
Cats and dogs each hate the other
The pipe began to rust while new
Open the crate but don't break the glass
Add the sum to the product of these three
Thieves who rob friends deserve jail
The ripe taste of cheese improves with age
Act on these orders with great speed
The hog crawled under the high fence
Move the vat over the hot fire

Harvard Sentence List #13

Type out three lists of orders
The harder he tried the less he got done
The boss ran the show with a watchful eye
The cup cracked and spilled its contents
Paste can cleanse the most dirty brass
The slang word for raw whiskey is booze
It caught its hind paw in a rusty trap
The wharf could be seen at the farther shore
Feel the heat of the weak dying flame
The tiny girl took off her hat

Harvard Sentence List #15

The young kid jumped the rusty gate
Guess the results from the first scores
A salt pickle tastes fine with ham
The just claim got the right verdict
These thistles bend in a high wind
Pure bred poodles have curls
The tree top waved in a graceful way
The spot on the blotter was made by green ink
Mud was spattered on the front of his white shirt
The cigar burned a hole in the desk top

Harvard Sentence List #17

The jacket hung on the back of the wide chair
At that high level the air is pure
Drop the two when you add the figures
A filing case is now hard to buy
An abrupt start does not win the prize
Wood is best for making toys and blocks
The office paint was a dull, sad tan
He knew the skill of the great young actress
A rag will soak up spilled water
A shower of dirt fell from the hot pipes

Harvard Sentence List #10

The slush lay deep along the street
A wisp of cloud hung in the blue air
A pound of sugar costs more than eggs
The fin was sharp and cut the clear water
The play seems dull and quite stupid
Bail the boat to stop it from sinking
The term ended in late June that year
A tusk is used to make costly gifts
Ten pins were set in order
The bill was paid every third week

Harvard Sentence List #12

The bark of the pine tree was shiny and dark
Leaves turn brown and yellow in the fall
The pennant waved when the wind blew
Split the log with a quick, sharp blow
Burn peat after the logs give out
He ordered peach pie with ice cream
Weave the carpet on the right hand side
Hemp is a week found in parts of the tropics
A lame back kept his score low
We find joy in the simplest things

Harvard Sentence List #14

A cramp is no small danger on a swim
He said the same phrase thirty times
Pluck the bright rose without leaves
Two plus seven is less than ten
The glow deepened in the eyes of the sweet girl
Bring your problems to the wise chief
Write a fond note to the friend you cherish
Clothes and lodging are free to new men
We frown when events take a bad turn
Port is a strong wine with a smokey taste

Harvard Sentence List #16

The empty flask stood on the tin tray
A speedy man can beat this track mark
He broke a new shoelace that day
The coffee stand is too high for the couch
The urge to write short stories is rare
The pencils have all been used
The pirates seized the crew of the lost ship
We tried to replace the coin but failed
She sewed the torn coat quite neatly
The sofa cushion is red and of light weight

Harvard Sentence List #18

Steam hissed from the broken valve
The child almost hurt the small dog
There was a sound of dry leaves outside
The sky that morning was clear and bright blue
Torn scraps littered the stone floor
Sunday is the best part of the week
The doctor cured him with these pills
The new girl was fired today at noon
They felt gay when the ship arrived in port
Add the store's account to the last cent

Harvard Sentence List #19

Acid burns holes in wool cloth
Fairy tales should be fun to write
Eight miles of woodland burned to waste
The third act was dull and tired the players
A young child should not suffer fright
Add the column and put the sum here
We admire and love a good cook
There the flood mark is ten inches
He carved a head from the round block of marble
She has a smart way of wearing clothes

Harvard Sentence List #21

The brown house was on fire to the attic
The lure is used to catch trout and flounder
Float the soap on top of the bath water
A blue crane is a tall wading bird
A fresh start will work such wonders
The club rented the rink for the fifth night
After the dance, they went straight home
The hostess taught the new maid to serve
He wrote his last novel there at the inn
Even the worst will beat his low score

Harvard Sentence List #23

A pencil with black lead writes best
Coax a young calf to drink from a bucket
Schools for ladies teach charm and grace
The lamp shone with a steady green flame
They took the axe and the saw to the forest
The ancient coin was quite dull and worn
The shaky barn fell with a loud crash
Jazz and swing fans like fast music
Rake the rubbish up and then burn it
Slash the gold cloth into fine ribbons

Harvard Sentence List #25

On the island the sea breeze is soft and mild
The play began as soon as we sat down
This will lead the world to more sound and fury
Add salt before you fry the egg
The rush for funds reached its peak tuesday
The birch looked stark white and lonesome
The box is held by a bright red snapper
To make pure ice, you freeze water
The first worm gets snapped early
Jump the fence and hurry up the bank

Harvard Sentence List #27

The dark pot hung in the front closet
Carry the pail to the wall and spill it there
The train brought our hero to the big town
We are sure that one war is enough
Gray paint stretched for miles around
The rude laugh filled the empty room
High seats are best for football fans
Tea served from the brown jug is tasty
A dash of pepper spoils beef stew
A zestful food is the hot-cross bun

Harvard Sentence List #20

The fruit of the fig tree is apple-shaped
Corn cobs can be used to kindle a fire
Where were they when the noise started
The paper box is full of thumb tacks
Sell your gift to a buyer at a god gain
The tongs lay beside the ice pail
The petals fall with the next puff of wind
Bring your best compass to the third class
They could laugh although they were sad
Farmers came in to thresh the oat crop

Harvard Sentence List #22

The cement had dried when he moved it
The loss of the second ship was hard to take
The fly made its way along the wall
Do that with a wooden stick
Live wires should be kept covered
The large house had hot water taps
It is hard to erase blue or red ink
Write at once or you may forget it
The doorknob was made of bright clean brass
The wreck occurred by the bank on main street

Harvard Sentence List #24

Try to have the court decide the case
They are pushed back each time they attack
He broke his ties with groups of former friends
They floated on the raft to sun their white backs
The map had an 'X' that meant nothing
Whittings are small fish caught in nets
Some ads serve to cheat buyers
Jerk the rope and the bell rings weekly
A waxed floor makes us lose balance
Madam, this is the best brand of corn

Harvard Sentence List #26

Yell and clap as the curtain slides back
They are men who walk the middle of the road
Both brothers wear the same size
In some form or other we need fun
The prince ordered his head chopped off
Theh ousas are built of red clay bricks
Ducks fly north but lack a compass
Fruit flavors are used in fizz drinks
These pills do less good than others
Canned pears lack full flavor

Harvard Sentence List #28

The horse trotted around the field at a brisk pace
Find the twin who stole the pearl necklace
Cut the cord that binds the box tightly
The red tape bound the smuggled food
Look in the corner to find the tan shirt
The cold drizzle will halt the bond drive
Nine men were hired to dig the ruins
The junk yard had a moldy smell
The flint sputtered and lit a pine torch
Soak the cloth and drown the sharp odor

Harvard Sentence List #29

The shelves were bare of both jam or crackers
A joy to every child is the swan boat
All sat frozen and watched the screen
A cloud of dust stung his tender eyes
To reach the end he needs much courage
Shape the clay gently into block form
A ridge on a smooth surface is a bump or flaw
Hedge apples may stain your hands green
Quench your thirst, then eat the crackers
Tight curls get limp on rainy days

Harvard Sentence List #31

Slide the box into that empty space
The plant grew large and green in the window
The beam dropped down on the workman's head
Pink clouds floated with the breeze
She danced like a swan, tall and graceful
The tube was blown and the tire flat and useless
It is late morning on the old wall clock
Let's all join as we sing the last chorus
The last switch cannot be turned off
The fight will end in just six minutes

Harvard Sentence List #33

Fill the ink jar with sticky glue
He smokes a big pipe with strong contents
We need grain to keep our mules healthy
Pack the records in a neat thin case
The crunch of feet in the snow was the only sound
The copper bown shone in the sun's rays
Boards will warp unless kept dry
The plush chair leaned against the wall
Glass will clink when struck by metal
Bathe and relax in the cool green grass

Harvard Sentence List #35

Most of the news is easy for us to hear
He used the lathe to make brass objects
The vane on top of the pole revolved in the wind
Mince pie is a dish served to children
The clan gathered on each dull night
Let it burn, it gives us warmth and comfort
A castle build from sand fails to endure
A child's wit saved the day for us
Tack the strip of carpet to the worn floor
Next tuesday we must vote

Harvard Sentence List #37

Feed the white mouse some flower seeds
The thaw came early and freed the stream
He took the lead and kept it the whole distance
The key you designed will fit the lock
Plead to the council to free the poor thief
Better hash is made of rare beef
This plank was made for walking on
The lake sparkled in the red hot sun
He crawled with care along the ledge
Tend the sheep while the dog wanders

Harvard Sentence List #30

The mute muffled the high tones of the horn
The gold ring fits only a pierced ear
The old pan was covered with hard fudge
Watch the log float in the wide river
The node on the stalk of wheat grew daily
The heap of fallen leaves was set on fire
Write fast if you want to finish early
His shirt was clean but one button was gone
The barrel of beer was a brew of malt and hops
Tin cans are absent from store shelves

Harvard Sentence List #32

The store walls were lined with colored frocks
The peace league met to discuss their plans
The rise to fame of a person takes luck
Paper is scarce, so write with much care
The quick fox jumped on the sleeping cat
The nozzle of the fire hose was bright brass
Screw the round cap on as tight as needed
Time brings us many changes
The purple tie was ten years old
Men think and plan and sometimes act

Harvard Sentence List #34

Nine rows of soldiers stood in line
The beach is dry and shallow at low tide
The idea is to sew both edges straight
The kitten chased the dog down the street
Pages bound in cloth make a book
Try to trace the fine lines of the painting
Women form less than half of the group
The zones merge in the central part of town
A gem in the rough needs work to polish
Code is used when secrets are sent

Harvard Sentence List #36

Pour the stew from the pot into the plate
Each penny shone like new
The man went to the woods to gather sticks
The dirt piles were lines along the road
The logs fell and tumbled into the clear stream
Just hoist it up and take it away
A ripe plum is fit for a king's palate
Our plans right now are hazy
Brass rings are sold by these natives
It takes a good trap to capture a bear

Harvard Sentence List #38

It takes a lot of help to finish these
Mark the spot with a sign painted red
Take two shares as a fair profit
The fur of cats goes by many names
North winds bring colds and fevers
He asks no person to vouch for him
Go now and come here later
A sash of gold silk will trim her dress
Soap can wash most dirt away
That move means the game is over

Harvard Sentence List #39

He wrote down a long list of items
A siege will crack the strong defense
Grape juice and water mix well
Roads are paved with sticky tar
Fake stones shine but cost little
The drip of the rain made a pleasant sound
Smoke poured out of every crack
Serve the hot rum to the tired heroes
Much of the story makes good sense
The sun came up to light the eastern sky

Harvard Sentence List #41

A pod is what peas always grow in
Jerk the dart from the cork target
No cement will hold hard wood
We now have a new base for shipping
A list of names is carved around the base
The sheep were led home by a dog
Three for a dime, the young peddler cried
The sense of smell is better than that of touch
No hardship seemed to keep him sad
Grace makes up for lack of beauty

Harvard Sentence List #43

Seed is needed to plant the spring corn
Draw the chart with heavy black lines
The boy owed his pal thirty cents
The chap slipped into the crowd and was lost
Hats are worn to tea and not to dinner
The ramp led up to the wide highway
Beat the dust from the rug onto the lawn
Say it slowly but make it ring clear
The straw nest housed five robins
Screen the porch with woven straw mats

Harvard Sentence List #45

They slice the sausage thin with a knife
The bloom of the rose lasts a few days
A gray mare walked before the colt
Breakfast buns are fine with a hot drink
Bottles hold four kinds of rum
The man wore a feather in his felt hat
He wheeled the bike past the winding road
Drop the ashes on the worn old rug
The desk and both chairs were painted tan
Throw out the used paper cup and plate

Harvard Sentence List #47

The music played on while they talked
Dispense with a vest on a day like this
The bunch of grapes was pressed into wine
He sent the figs, but kept the ripe cherries
The hinge on the door creaked with old age
The screen before the fire kept in the sparks
Fly by night, and you waste little time
Thick glasses helped him read the print
Birth and death mark the limits of life
The chair looked strong but had no bottom

Harvard Sentence List #40

Heave the line over the port side
A lathe cuts and trims any wood
It's a dense crowd in two distinct ways
His hip struck the knee of the next player
The stale smell of old beer lingers
The desk was firm on the shaky floor
It takes heat to bring out the odor
Beef is scarcer than some lamb
Raise the sail and steer the ship northward
A cone costs five cents on Mondays

Harvard Sentence List #42

Nudge gently but wake her now
The news struck doubt in the restless mind
Once we stood beside the shore
A chink in the wall allowed a draft to blow
Fasten two pins on each side
A cold dip restores health and zest
He takes the oath of office each march
The sand drifts over the sill of the old house
The point of the steel pen was bent and twisted
There is a lag between thought and act

Harvard Sentence List #44

This horse will nose his way to the finish
The dry wax protects the deep scratch
He picked up the dice for a second roll
These coins will be needed to pay his debt
The nag pulled the frail cart along
Twist the valve and release hot steam
The vamp of the shoe had a gold buckle
The smell of burned rags itches my nose
New pants lack cuffs and pockets
The marsh will freeze when cold enough

Harvard Sentence List #46

A clean neck means a neat collar
The couch cover and hall drapes were blue
The stems of the tall glasses cracked and broke
The wall phone rang loud and often
The clothes dried on a thin wooden rack
Turn on the lantern which gives us light
The cleat sank deeply into the soft turf
The bills were mailed promptly on the tenth of the month
To have is better than to wait and hope
The prices is fair for a good antique clock

Harvard Sentence List #48

The kite flew wildly in the high wind
A fur muff is stylish once more
The tin box held priceless stones
We need an end of all such matter
The case was puzzling to the old and wise
The bright lanterns were gay on the dark lawn
We don't get much money but we have fun
The youth drove with zest, but little skill
Five years he lived with a shaggy dog
A fence cuts through[h] the corner lot

Harvard Sentence List #49

The way to save money is not to spend much
Shut the hatch before the waves push it in
The odor of spring makes young hearts jump
Crack the walnut with your sharp side teeth
He offered proof in the form of a large chart
Send the stuff in a thick paper bag
A quart of milk is water for the most part
They told wild tales to frighten him
The three story house was built of stone
In the rear of the ground floor was a large passage

Harvard Sentence List #51

Shake the dust from your shoes, stranger
She was kind to sick old people
The square wooden crate was packed to be shipped
The dusty bench stood by the stone wall
We dress to suit the weather of most days
Smile when you say nasty words
A bowl of rice is free with chicken stew
The water in this well is a source of good health
Take shelter in this tent, but keep still
That guy is the writer of a few banned books

Harvard Sentence List #53

Press the pedal with your left foot
Neat plans fail without luck
The black trunk fell from the landing
The bank pressed for payment of the debt
The theft of the pearl pin was kept secret
Shake hands with this friendly child
The vast space stretched into the far distance
A rich farm is rare in this sandy waste
His wide grin earned many friends
Flax makes a fine brand of paper

Harvard Sentence List #55

Those last words were a strong statement
He wrote his name boldly at the top of the sheet
Dill pickles are sour but taste fine
Down that road is the way to the grain farmer
Either mud or dust are found at all times
The best method is to fix it in place with clips
If you mumble your speech will be lost
At night the alarm roused him from a deep sleep
Read just what the meter says
Fill your pack with bright trinkets for the poor

Harvard Sentence List #57

Paint the socket in the wall dull green
The child crawled into the dense grass
Bribes fail where honest men work
Trample the spark, else the flames will spread
The hilt of the sword was carved with fine designs
A round hole was drilled through the thin board
Footprints showed the path he took up the beach
She was waiting at my front lawn
A vent near the edge brought in fresh air
Prod the old mule with a crooked stick

Harvard Sentence List #50

A man in a blue sweater sat at the desk
Oats are a food eaten by horse and man
Their eyelids droop for want of sleep
A sip of tea revives his tired friend
There are many ways to do these things
Tuck the sheet under the edge of the mat
A force equal to that would move the earth
We like to see clear weather
The work of the tailor is seen on each side
Take a chance and win a china doll

Harvard Sentence List #52

The little tales they tell are false
The door was barred, locked, and bolted as well
Ripe pears are fit for a queen's table
A big wet stain was on the round carpet
The kite dipped and swayed, but stayed aloft
The pleasant hours fly by much too soon
The room was crowded with a wild mob
This strong arm shall shield your honor
She blushed when he gave her a white orchid
The beetle droned in the hot June sun

Harvard Sentence List #54

Hurdle the pit with the aid of a long pole
A strong bid may scare your partner stiff
Even a just cause needs power to win
Peep under the tent and see the clowns
The leaf drifts along with a slow spin
Cheap clothes are flashy but don't last
A thing of small note can cause d[e]spair
Flood the mails with requests for this book
A thick coat of black paint covered all
The pencil was cut to be sharp at both ends

Harvard Sentence List #56

The small red neon lamp went out
Clams are small, round, soft, and tasty
The fan whirled its round blades softly
The line where the edges join was clean
Breathe deep and smell the piny air
It matters not if he reads these words or those
A brown leather bag hung from its strap
A toad and a frog are hard to tell apart
A white silk jacket goes with any shoes
A break in the dam almost caused a flood

Harvard Sentence List #58

It is a band of steel three inches wide
The pipe ran almost the length of the ditch
It was hidden from sight by a mass of leaves and shrubs
The weight of the package was seen on the high scale
Wake and rise, and step into the green outdoors
The green light in the brown box flickered
The brass tube circled the high wall
The lobes of her ears were pierced to hold rings
Hold the hammer near the end to drive the nail
Next Sunday is the twelfth of the month

Harvard Sentence List #59

Every word and phrase he speaks is true
He put his last cartridge into the gun and fired
They took their kids from the public school
Drive the screw straight into the wood
Keep the hatch tight and the watch constant
Sever the twine with a quick snip of the knife
Paper will dry out when wet
Slide the catch back and open the desk
Help the weak to preserve their strength
A sullen smile gets few friends

Harvard Sentence List #61

A plea for funds seems to come again
He lent his coat to the tall gaunt stranger
There is a strong chance it will happen once more
The duke left the park in a silver coach
Greet the new guests and leave quickly
When the frost has come it is time for turkey
Sweet words work better than fierce
A thin stripe runs down the middle
A six comes up more often than a ten
Lush fern grow on the lofty rocks

Harvard Sentence List #63

The goose was brought straight from the old market
The sink is the thing in which we pile dishes
A whiff of it will cure the most stubborn cold
The facts don't always show who is right
She flaps her cape as she parades down the street
The loss of the cruiser was a blow to the fleet
Loop the braid to the left and then over
Plead with the lawyer to drop the lost cause
Calves thrive on tender spring grass
Post no bills on this office wall

Harvard Sentence List #65

Ship maps are different from those for planes
Dimes showered down from all sides
They sang the same tunes at each party
The sky in the West is tinged with orange red
The pods of peas ferment in bare fields
The horse balked and threw the tall rider
The hitch between the horse and cart broke
Pile the coal high in the shed corner
A gold vase is both rare and costly
The knife was hung inside its bright sheath

Harvard Sentence List #67

Hang tinsel from both branches
Cap the jar with a tight brass cover
The poor boy missed the boat again
Be sure to set the lamp firmly in the hole
Pick a card and slip it under the pack
A round mat will cover the dull spot
The first part of the plan needs changing
A good book informs of what we ought to know
The mail comes in three batches per day
You cannot brew tea in a cold pot

Harvard Sentence List #60

Stop whistling and watch the boys march
Jerk the cord, and out tumbles the gold
Slide the tray across the glass top
The cloud moved in a stately way and was gone
Light maple makes for a swell room
Set the piece here and say nothing
Dull stories make her laugh
A stiff cord will do to fasten your shoe
Get the trust fund to the bank early
Choose between the high road and the low

Harvard Sentence List #62

The ram scared the school children off
The team with the best timing looks good
The farmer swapped his horse for a brown ox
Sit on the perch and tell the others what to do
A steep trail is painful for our feet
The early phase of life moves fast
Green moss grows on the northern side
Tea in thin china has a sweet taste
Pitch the straw through the door of the stable
The latch on the back gate needed a nail

Harvard Sentence List #64

Tear a thin sheet from the yellow pad
A cruise in warm waters in a sleek yacht is fun
A streak of color ran down the left edge
It was done before the boy could see it
Crouch before you jump or miss the mark
Pack the kits and don't forget the salt
The square peg will settle in the round hole
Fine soap saves tender skin
Poached eggs and tea must suffice
Bad nerves are jangled by a door slam

Harvard Sentence List #66

The rarest spice comes from the far east
The roof should be tilted at a sharp slant
A smatter of french is worse than none
The mule trod the treadmill day and night
The aim of the contest is to raise a great fund
To send it now in large amounts is bad
There is a fine hard tang in salty air
Cod is the main business of the North shore
The slab was hewn from heavy blocks of slate
Dunk the stale biscuit into strong drink

Harvard Sentence List #68

Dots of light betrayed the black cat
Put the chart on the mantel and tack it down
The night shift men rate extra pay
The red paper brightened the dim stage
See the player scoot to third base
Slide the bill between the two leaves
Many hands help get the job done
We don't like to admit our small faults
No doubt about the way the wind blows
Dig deep in the earth for pirate's gold

Harvard Sentence List #69

The steady drip is worse than a drenching rain
A flat pack takes less luggage space
Green ice frosted the punch bowl
A stuffed chair slipped from the moving van
The stitch will serve but needs to be shortened
A thin book fits in the side pocket
The gloss on top made it unfit to read
The hail pattered on the burnt brown grass
Seven seals were stamped on great sheets
Our troops are set to strike heavy blows

Harvard Sentence List #71

Open your book to the first page
Fish evade the net and swim off
Dip the pail once and let it settle
Will you please answer the phone
The big red apple fell to the ground
The curtain rose and the show was on
The young prince became heir to the throne
He sent the boy on a short errand
Leave now and you will arrive on time
The corner store was robbed last night

Harvard Sentence List #70

The store was jammed before the sale could start
It was a bad error on the part of the new judge
 One step more and the board will collapse
Take the match and strike it against your shoe
 The pot boiled, but the contents failed to jell
 The baby puts his right foot in his mouth
 The bombs left most of the town in ruins
 Stop and stare at the hard working man
The streets are narrow and full of sharp turns
The pup jerked the leash as he saw a feline shape

Harvard Sentence List #72

 A gold ring will please most any girl
 The long journey home took a year
 She saw a cat in the neighbor's house
A pink shell was found on the sandy beach
 Small children came to see him
The grass and bushes were wet with dew
 The blind man counted his old coins
 A severe storm tore down the barn
 She called his name many times
When you hear the bell, come quickly

A.2 Diagnostic Rhyme Test Stimulus Words

Table A.1: DRT Stimulus Words

Voicing		Nasality		Sustension	
Veal	Feel	Meat	Beat	Vee	Bee
Bean	Peen	Need	Deed	Sheet	Cheat
Gin	Chin	Mitt	Bit	Vill	Bill
Dint	Tint	Nip	Dip	Thick	Tick
Zoo	Sue	Moot	Boot	Foo	Pooh
Dune	Tune	News	Dues	Shoes	Choose
Vole	Foal	Moan	Bone	Those	Doze
Goat	Coat	Note	Dote	Though	Dough
Zed	Said	Mend	Bend	Then	Den
Dense	Tense	Neck	Deck	Fence	Pence
Vast	Fast	Mad	Bad	Than	Dan
Gaff	Calf	Nab	Dab	Shad	Chad
Vault	Fault	Moss	Boss	Thong	Tong
Daunt	Taunt	Gnaw	Daw	Shaw	Chaw
Jock	Chock	Mom	Bomb	Von	Bon
Bond	Pond	Knock	Dock	Vox	Box
Sibilation		Graveness		Compactness	
Zee	Thee	Weed	Reed	Yield	Wield
Cheep	Keep	Peak	Teak	Key	Tea
Jilt	Gilt	Bid	Did	Hit	Fit
Sing	Thing	Fin	Thin	Gill	Dill
Juice	Goose	Moon	Noon	Coop	Poop
Chew	Coo	Pool	Tool	You	Rue
Joe	Go	Bowl	Dole	Ghost	Boast
Sole	Thole	Fore	Thor	Show	So
Jest	Guest	Met	Net	Keg	Peg
Chair	Care	Pent	Tent	Yen	Wren
Jab	Gab	Bank	Dank	Gat	Bat
Sank	Thank	Fad	Thad	Shag	Sag
Jaws	Gauze	Fought	Thought	Yawl	Wall
Saw	Thaw	Bong	Dong	Caught	Thought
Jot	Got	Wad	Rod	Hop	Fop
Chop	Cop	Pot	Tot	Got	Dot

A.3 Phonetically Balanced (PB-50) Word Lists

Table A.2: PB-50 Word Lists

PB-50 List #1					
1. are	11. death	21. fuss	31. not	41. rub	
2. bad	12. deed	22. grove	32. pan	42. slip	
3. bar	13. dike	23. heap	33. pants	43. smile	
4. bask	14. dish	24. hid	34. pest	44. strife	
5. box	15. end	25. hive	35. pile	45. such	
6. cane	16. feast	26. hunt	36. plush	46. then	
7. cleanse	17. fern	27. is	37. rag	47. there	
8. clove	18. folk	28. mange	38. rat	48. toe	
9. crash	19. ford	29. no	39. ride	49. use	
10. creed	20. fraud	30. nook	40. rise	50. wheat	
PB-50 List #2					
1. awe	11. dab	21. hock	31. perk	41. start	
2. bait	12. earl	22. job	32. pick	42. suck	
3. bean	13. else	23. log	33. pit	43. tan	
4. blush	14. fate	24. moose	34. quart	44. tang	
5. bought	15. five	25. mute	35. rap	45. them	
6. bounce	16. frog	26. nab	36. rib	46. trash	
7. bud	17. gill	27. need	37. scythe	47. vamp	
8. charge	18. gloss	28. niece	38. shoe	48. vast	
9. cloud	19. hire	29. nut	39. sludge	49. ways	
10. corpse	20. hit	30. our	40. snuff	50. wish	
PB-50 List #3					
1. ache	11. crime	21. hurl	31. please	41. take	
2. air	12. deck	22. jam	32. pulse	42. thrash	
3. bald	13. dig	23. law	33. rate	43. toil	
4. barb	14. dill	24. leave	34. rouse	44. trip	
5. bead	15. drop	25. lush	35. shout	45. turf	
6. cape	16. fame	26. muck	36. sit	46. vow	
7. cast	17. far	27. neck	37. size	47. wedge	
8. check	18. fig	28. nest	38. sob	48. wharf	
9. class	19. flish	29. oak	39. sped	49. who	
10. crave	20. gnaw	30. path	40. stag	60. why	
PB-50 List #4					
1. bath	11. dodge	21. hot	31. pert	41. shed	
2. beast	12. dupe	22. how	32. pinch	42. shin	
3. bee	13. earn	23. kite	33. pod	43. sketch	

Table A.2: (continued)

cont.						
4. blonde	14. eel	24. merge	34. race	44. slap		
5. budge	15. fin	25. move	35. rack	45. sour		
6. bus	16. float	26. neat	36. rave	46. starve		
7. bush	17. frown	27. new	37. raw	47. strap		
8. cloak	18. hatch	28. oils	38. rut	48. test		
9. course	19. heed	29. or	39. sage	49. tick		
10. court	20. hiss	30. peck	40. scab	50. touch		
PB-50 List #5						
1. add	11. flap	21. love	31. rind	41. thud		
2. bathe	12. gape	22. mast	32. rode	42. trade		
3. beck	13. good	23. nose	33. roe	43. true		
4. black	14. greek	24. odds	34. scare	44. tug		
5. bronze	15. grudge	25. owls	35. shine	45. vase		
6. browse	16. high	26. pass	36. shove	46. watch		
7. cheat	17. hill	27. pipe	37. sick	47. wink		
8. choose	18. inch	28. puff	38. sly	48. wrath		
9. curse	19. kid	29. punt	39. solve	49. yawn		
10. feed	20. lend	30. rear	40. thick	50. zone		
PB-50 List #6						
1. as	11. deep	21. gap	31. prig	41. shank		
2. badge	12. eat	22. grope	32. prime	42. slouch		
3. best	13. eyes	23. hitch	33. pun	43. sup		
4. bog	14. fall	24. hull	34. pus	44. thigh		
5. chart	15. fee	25. jag	35. raise	45. thus		
6. cloth	16. flick	26. kept	36. ray	46. tongue		
7. clothes	17. clop	27. leg	37. reap	47. wait		
8. cob	18. forge	28. mash	38. rooms	48. wasp		
9. crib	19. fowl	29. nigh	39. rough	49. wife		
10. dad	20. gage	30. ode	40. scan	50. writ		
PB-50 List #7						
1. act	11. dope	21. jug	31. pounce	41. siege		
2. aim	12. dose	22. knit	32. quiz	42. sin		
3. am	13. dwarf	23. mote	33. raid	43. sledge		
4. but	14. fake	24. mud	34. range	44. sniff		
5. by	15. fling	25. nine	35. rash	45. south		
6. chop	16. fort	26. off	36. rich	46. though		
7. coast	17. gasp	27. pent	37. roar	47. whiff		
8. comes	18. grade	28. phase	38. sag	48. wire		
9. cook	19. gun	29. pig	39. scout	49. woe		

Table A.2: (continued)

cont.						
10. cut	20. him	30. plod	40. shaft	50. woo		
PB-50 List #8						
1. ask	11. cod	21. forth	31. look	41. shack		
2. bid	12. crack	22. freak	32. night	42. slide		
3. bind	13. day	23. frock	33. pint	43. spice		
4. bolt	14. deuce	24. front	34. queen	44. this		
5. bored	15. dumb	25. guess	35. rest	45. thread		
6. calf	16. each	26. hum	36. rhyme	46. till		
7. catch	17. ease	27. jell	37. rod	47. us		
8. chant	18. fad	28. kill	38. roll	48. wheeze		
9. chew	19. flip	29. left	39. rope	49. wig		
10. clod	20. food	30. lick	40. rot	50. yeast		
PB-50 List #9						
1. arch	11. crowd	21. grace	31. odd	41. than		
2. beef	12. cud	22. hoof	32. pact	42. thank		
3. birth	13. ditch	23. ice	33. phone	43. throne		
4. bit	14. flag	24. itch	34. reed	44. toad		
5. boost	15. fluff	25. key	35. root	45. troop		
6. carve	16. foe	26. lit	36. rude	46. weak		
7. chess	17. fume	27. mass	37. sip	47. wild		
8. chest	18. fuse	28. nerve	38. smart	48. wipe		
9. clown	19. gate	29. noose	39. spud	49. with		
10. club	20. give	30. nuts	40. ten	50. year		
PB-50 List #10						
1. ail	11. cue	21. gull	31. pink	41. staff		
2. back	12. daub	22. hat	32. plus	42. tag		
3. bash	13. ears	23. hurt	33. put	43. those		
4. bob	14. earth	24. jay	34. rape	44. thug		
5. bug	15. etch	25. lap	35. real	45. tree		
6. champ	16. fir	26. line	36. rip	46. valve		
7. chance	17. flaunt	27. maze	37. rush	47. void		
8. clothe	18. flight	28. mope	38. scrub	48. wake		
9. cord	19. force	29. nudge	39. slug	49. wake		
10. cow	20. goose	30. page	40. snipe	50. youth		
PB-50 List #11						
1. arc	11. doubt	21. jab	31. pond	41. shot		
2. arm	12. drake	22. jaunt	32. prove	42. sign		
3. beam	13. dull	23. kit	33. prod	43. snow		
4. bliss	14. feel	24. lag	34. punk	44. sprig		

Table A.2: (continued)

cont.						
5. chunk	15. fine	25. latch	35. purse	45. spy		
6. clash	16. frisk	26. loss	36. reef	46. stiff		
7. code	17. fudge	27. low	37. rice	47. tab		
8. crutch	18. goat	28. most	38. risk	48. urge		
9. cry	19. have	29. mouth	39. sap	49. wave		
10. dip	20. hog	30. net	40. shop	50. wood		
PB-50 List #12						
1. and	11. cling	21. frill	31. lash	41. rove		
2. ass	12. clutch	22. gnash	32. laugh	42. set		
3. ball	13. depth	23. greet	33. ledge	43. shut		
4. bluff	14. dime	24. hear	34. loose	44. sky		
5. cad	15. done	25. hug	35. out	45. sod		
6. cave	16. fed	26. hunch	36. park	46. throb		
7. chafe	17. flog	27. jaw	37. priest	47. tile		
8. chair	18. flood	28. jazz	38. reek	48. vine		
9. chap	19. foot	29. jolt	39. ripe	49. wage		
10. chink	20. fought	30. knife	40. romp	50. wove		
PB-50 List #13						
1. bat	11. few	21. jig	31. nip	41. sled		
2. beau	12. fill	22. made	32. ought	42. smash		
3. change	13. fold	23. mood	33. owe	43. smooth		
4. climb	14. for	24. mop	34. patch	44. soap		
5. corn	15. gem	25. moth	35. pelt	45. stead		
6. curb	16. grape	26. muff	36. plead	46. taint		
7. deaf	17. grave	27. mush	37. price	47. tap		
8. dog	18. hack	28. my	38. pug	48. thin		
9. elk	19. hate	29. nag	39. scuff	49. tip		
10. elm	20. hook	30. nice	40. side	50. wean		
PB-50 List #14						
1. at	11. dead	21. isle	31. prude	41. stuff		
2. barn	12. douse	22. kick	32. purge	42. tell		
3. bust	13. dung	23. lathe	33. quack	43. tent		
4. car	14. fife	24. life	34. rid	44. thy		
5. clip	15. foam	25. me	35. shook	45. tray		
6. coax	16. grate	26. muss	36. shrug	46. vague		
7. curve	17. group	27. news	37. sing	47. vote		
8. cute	18. heat	28. nick	38. slab	48. wag		
9. darn	19. howl	29. nod	39. smite	49. waif		

Table A.2: (continued)

cont.							
10. dash	20. hunk	30. oft	40. soil	50. wrist			
PB-50 List #15							
1. bell	11. fact	21. less	31. pup	41. teach			
2. blind	12. flame	22. may	32. quick	42. that			
3. boss	13. fleet	23. mesh	33. scow	43. time			
4. cheap	14. gash	24. mitt	34. sense	44. tinge			
5. cost	15. glove	25. mode	35. shade	45. tweed			
6. cuff	16. golf	26. morn	36. shrub	46. vile			
7. dive	17. hedge	27. naught	37. sir	47. weave			
8. dove	18. hole	28. ninth	38. slash	48. wed			
9. edge	19. jade	29. oath	39. so	49. wide			
10. elf	20. kiss	30. own	40. tack	50. wreck			
PB-50 List #16							
1. aid	11. droop	21. kind	31. pump	41. stress			
2. barge	12. dub	22. knee	32. rock	42. suit			
3. book	13. fifth	23. lay	33. rogue	43. thou			
4. cheese	14. fright	24. leash	34. rug	44. three			
5. cliff	15. gab	25. louse	35. rye	45. thresh			
6. closed	16. gas	26. map	36. sang	46. tire			
7. crews	17. had	27. nap	37. sheep	47. ton			
8. dame	18. hash	28. next	38. sheik	48. tuck			
9. din	19. hose	29. part	39. soar	49. turn			
10. drape	20. ink	30. pitch	40. stab	50. wield			
PB-50 List #17							
1. all	11. crush	21. hence	31. past	41. sell			
2. apt	12. dart	22. hood	32. pearl	42. ship			
3. bet	13. dine	23. if	33. peg	43. shock			
4. big	14. falls	24. last	34. plow	44. stride			
5. booth	15. feet	25. ma	35. press	45. tube			
6. brace	16. fell	26. mist	36. rage	46. vice			
7. braid	17. fit	27. myth	37. reach	47. weep			
8. buck	18. form	28. ox	38. ridge	48. weird			
9. case	19. fresh	29. paid	39. roam	49. wine			
10. clew	20. gum	30. pare	40. scratch	50. you			
PB-50 List #18							
1. aims	11. chip	21. flare	31. hush	41. sack			
2. art	12. claw	22. fool	32. lime	42. sash			
3. axe	13. claws	23. freeze	33. lip	43. share			
4. bale	14. crab	24. got	34. loud	44. sieve			

Table A.2: (continued)

cont.					
5. bless	15. cub	25. grab	35. lunge	45. thaw	
6. camp	16. debt	26. gray	36. lynch	46. thine	
7. cat	17. dice	27. grew	37. note	47. thorn	
8. chaff	18. dot	28. gush	38. ouch	48. trod	
9. chain	19. fade	29. hide	39. rob	49. waste	
10. chill	20. fat	30. his	40. rose	50. weed	

A.4 Sustained Vowel Word Lists

Table A.3: Vowel Word Lists

Vowel Word List #1 Vowel Word List #2 Vowel Word List #3

Hut	Cup	Luck
Hat	Cat	Black
Hurt	Turn	Learn
Hit	Fit	Sit
Heat	See	Feet
Hot	Pot	Rock
Hore	Call	Four
Hood	Put	Could
Hive	Five	Eye
How	Now	Out
Home	Go	Tome
Hair	Where	Air
Here	Near	Pear
Hoy	Boy	Join

APPENDIX B
WPI PILOT CORPUS

*The complete WPI Pilot Corpus is included
on DVD in the hard copies of this document
Those in possession of an electronic copy
with questions about the Corpus may direct
them to kevink@alum.wpi.edu*

BIBLIOGRAPHY

- [BK03] J. Beh and H. Ko. A novel spectral subtraction scheme for robust speech recognition: Spectral subtraction using spectral harmonics of speech. In *Proceedings of the ICASSP*, volume 1, pages I648–I651, Philadelphia, PA, April 2003.
- [BLP⁺02] D.R. Brown III, R. Ludwig, A. Pelteku, G. Bogdanov, and K. Keenaghan. A novel non-acoustic voiced speech sensor. Submitted to the *Journal of Measurement Science and Technology*, June 2002.
- [Bur99] G. Burnett. *The Physiological Basis of Glottal Electromagnetic Micropower Sensors (GEMS) and Their Use in Defining an Excitation Function for the Human Vocal Tract*. PhD thesis, University of California, Davis, 1999.
- [CO96] S.-M. Chi and Y.-H. Oh. Lombard effect compensation and noise suppression for noisy Lombard speech recognition. In *Proceedings of the ICSLP*, volume 4, pages 2013–2016, Philadelphia, PA, October 1996.
- [Cou01] L.W. Couch II. *Digital and Analog Communication Systems*. Prentice Hall, Inc., New Jersey, 6th edition, 2001.
- [DP93] P.B. Denes and E.N. Pinson. *The Speech Chain - The Physics and Biology of Spoken Language*. W.H. Freedman and Co., New York, 2nd edition, November 1993.
- [Edi00] Editors of The American Heritage Dictionaries, editor. *The American Heritage Dictionary of the English Language*. Houghton Mifflin Company, Boston, 4th edition, January 2000.
- [Ega48] J.P. Egan. Articulation testing methods. *Laryngoscope*, 58:955–991, 1948.
- [Fai58] G. Fairbanks. Test of phonemic differentiation: The rhyme test. *The Journal of the Acoustical Society of America*, 30(7):596–600, July 1958.
- [Fan02] J. Faneuff. Spatial, spectral, and perceptual nonlinear noise reduction for hands-free microphones in a car. Master’s thesis, Worcester Polytechnic Institute, July 2002.
- [Far40] D.W. Farnsworth. High-speed motion pictures of the human vocal cords. *Bell Lab Record*, 18(7):203–208, 1940.
- [FJ67] B. Frøkjær-Jensen. A photo-electric glottograph. *Annual Report of the Institute of Phonetics of the University of Copenhagen*, 4:5–19, 1967.

- [Fry79] D.B. Fry. *The Physics of Speech*. Cambridge University Press, Cambridge, April 1979.
- [Gar55] M. Garcia. Observations on the human voice. *Proceedings of the Royal Society, London*, 7:399–410, 1854-1855.
- [Hes83] W. Hess. *Pitch Determination of Speech Signals - Algorithms and Devices*. Springer-Verlag, Berlin, Heidelberg, April 1983.
- [Hoo97] P. Hoole. Techniques for investigating laryngeal articulation and the voice-source. *Forschungsberichte des Instituts für Phonetik und Sprachliche Kommunikation der Universität München*, 35:101–106, 1997.
- [HWHK65] A.S. House, C.E. Williams, M. Hecker, and K.D. Kryter. Articulation-testing methods: Consonantal differentiation with a closed-response set. *The Journal of the Acoustical Society of America*, 37(1):158–166, January 1965.
- [Jek93] U. Jekosch. Speech quality assessment and evaluation. In *Proceedings of the European Conference on Speech Communication and Technology*, pages 1387–1394, 1993.
- [Jun93] J.C. Junqua. The Lombard reflex and its role on human listeners and automatic speech recognizers. *The Journal of the Acoustical Society of America*, 93(1):510–524, 1993.
- [Lem99] S. Lemmetty. Review of speech synthesis technology. Master’s thesis, Helsinki University of Technology, March 1999.
- [LM87] H. Liang and N. Malik. Reducing cocktail party noise by adaptive array filtering. In *Proceedings of the ICASSP*, volume 12, pages 185–188, April 1987.
- [Mar82] P. Martin. Comparison of pitch detection by cepstrum and spectral comb analysis. In *Proceedings of the ICASSP*, volume 7, pages 180–183, May 1982.
- [Pel04] A. Pelteku. Development of an electromagnetic glottal waveform sensor for applications in high acoustic noise environments. Master’s thesis, Worcester Polytechnic Institute, February 2004.
- [PNG85] D.B. Pisoni, H.C. Nusbaum, and B.G. Greene. Perception of synthetic speech generated by rule. *Proceedings of the IEEE*, 73(11):1665–1676, November 1985.

- [RGR97] C. Rosse and P. Gaddum-Rosse. *Hollinshead's Textbook of Anatomy*. Lippincott-Raven Publishers, Philadelphia, New York, 5th edition, March 1997.
- [Sca98] M. Scanlon. Acoustic sensor for health status monitoring. In *Proceedings of IRIS Acoustic and Seismic Sensing*, volume 2, pages 205–22, 1998.
- [Sch68] M.R. Schroeder. Period histogram and product spectrum: New methods for fundamental frequency measurement. *Journal of the Acoustical Society of America*, 43:829–834, 1968.
- [SH68] M. Sawashima and H. Hirose. New laryngoscopic technique by use of fiber optics. *Journal of the Acoustical Society of America*, 43(1):168–169, 1968.
- [Son60] B. Sonesson. On the anatomy and vibratory pattern of the human vocal folds. *Acta Oto-Laryngologica, Supplement*, 156:1–80, 1960.
- [Son75] M.M. Sondhi. Measurement of the glottal waveform. *Journal of the Acoustical Society of America*, 57:228–232, 1975.
- [SR79] T.V. Sreenivas and P.V.S. Rao. Pitch extraction from corrupted harmonics of the power spectrum. *Journal of the Acoustical Society of America*, 65:223–228, 1979.
- [VCM65] W.D. Voiers, M.F. Cohen, and J. Mickunas. Evaluation of speech processing devices, i. intelligibility, quality, speaker recognizability. *Final Report, Contract No. AF19(628)4195, OAS*, 1965.
- [Voi77] W.D. Voiers. Articulation testing methods. *Benchmark Papers in Acoustics*, 11:374–387, 1977.
- [Wen91] C. Wenzel. Low frequency circulator/isolator uses no ferrite or magnet. 1991 RF design awards contest, Wenzel Associates, Inc., 1991.
- [YS02] J. Yamauchi and T. Shimamura. Noise estimation using high frequency regions for speech enhancement in low snr environments. In *IEEE Workshop Proceedings, Speech Coding*, pages 59–61, October 2002.

This document was typeset by the author with the $\text{\LaTeX} 2_{\epsilon}$ Documentation System.