

2016-01-27

An Initial Exploration of a Multi-Sensory Design Space: Tactile Support for Walking in Immersive Virtual Environments

Mi Feng

Worcester Polytechnic Institute

Follow this and additional works at: <https://digitalcommons.wpi.edu/etd-theses>

Repository Citation

Feng, Mi, "An Initial Exploration of a Multi-Sensory Design Space: Tactile Support for Walking in Immersive Virtual Environments" (2016). *Masters Theses (All Theses, All Years)*. 141.

<https://digitalcommons.wpi.edu/etd-theses/141>

This thesis is brought to you for free and open access by [Digital WPI](#). It has been accepted for inclusion in Masters Theses (All Theses, All Years) by an authorized administrator of Digital WPI. For more information, please contact wpi-etd@wpi.edu.

**An Initial Exploration of a Multi-Sensory Design Space:
Tactile Support for Walking in Immersive Virtual Environments**

by

Mi Feng

A Thesis

Submitted to the Faculty

of the

WORCESTER POLYTECHNIC INSTITUTE

in partial fulfillment of the requirements for the

Degree of Master of Science

in

Computer Science

January 2016

APPROVED:

Professor Robert W. Lindeman, Thesis Advisor

Professor Mark Claypool, Thesis Reader

Professor Craig E. Wills, Head of Department

Abstract

Multi-sensory feedback can potentially improve user experience and performance in virtual environments. As it is complicated to study the effect of multi-sensory feedback as a single factor, we created a design space with these diverse cues, categorizing them into an appropriate granularity based on their origin and use cases. To examine the effects of tactile cues during non-fatiguing walking in immersive virtual environments, we selected certain tactile cues from the design space, movement wind, directional wind and footstep vibration, and another cue, footstep sounds, and investigated their influence and interaction with each other in more detail. We developed a virtual reality system with non-fatiguing walking interaction and low-latency, multi-sensory feedback, and then used it to conduct two successive experiments measuring user experience and performance through a triangle-completion task. We noticed some effects due to the addition of footstep vibration on task performance, and saw significant improvement due to the added tactile cues in reported user experience.

Acknowledgements

I would like to express my deepest gratitude to my advisor, Professor Robert W. Lindeman, who exposed me to the wonderful hardware world in virtual reality, instructed me throughout the development of the system, and gave me many valuable advices on research exploration as well as programming.

I would like to thank my thesis reader, Mark Claypool, who listened to my research work during GRIE poster symposium and gave me detailed and helpful comments, suggestions in depth, as well as encouragement.

I would like to thank the post-doctoral fellow in HIVE lab, Arindam Dey, from whom I learnt the whole process about experimental design, data analysis and discussion. He kept encouraging me during my very first user study.

I would like to thank the forty participants for their voluntary participation in our two experiments.

Finally, I would like to thank my parents, who supported me overseas during the two years, and taught me problem-solving skills, from which I could benefit throughout life.

Table of Contents

Abstract.....	ii
Acknowledgements.....	iii
List of Figures.....	vi
List of Tables.....	viii
1 Introduction.....	1
1.1 Design Space of Multi-Sensory Cues.....	1
1.2 Our Work.....	3
1.3 Contributions.....	4
2 Related Work.....	5
2.1 Selected Secondary Cues in VR.....	5
2.1.1 Wind in VR.....	5
2.1.2 Vibrotactile-enhanced Footstep Simulations in VR.....	7
2.2 Path Integration in VR.....	8
3 System Implementation.....	9
3.1 Physical Layout.....	9
3.2 Wind Module.....	11
3.2.1 Hardware and Firmware.....	11
3.2.2 Software.....	14
3.3 Floor Vibration Module.....	17
3.3.1 Hardware.....	17
3.3.2 Software.....	18
4 Empirical Study.....	20
4.1 Experimental Task.....	20
4.2 Experiment 1: Movement Wind, Floor Vibration and Sound.....	21
4.2.1 Experimental Design.....	21
4.2.2 Procedure.....	23
4.2.3 Measures.....	24

4.2.4	Participants.....	26
4.2.5	Path Visualization.....	26
4.2.6	Results.....	27
4.2.7	Discussion.....	34
4.3	Follow-up Experiment.....	35
4.3.1	Experimental Design.....	36
4.3.2	Participants.....	36
4.3.3	Results.....	36
4.3.4	Discussion.....	39
5	Conclusion.....	41
	References.....	43
Appendix A	Communication Protocol	48
Appendix B	Grouped Path Visualizations	50

List of Figures

Figure 1: The primary components of our VR system	10
Figure 2: The view through Oculus Rift (left) and lab setup (right).....	10
Figure 3: System architecture	11
Figure 4: Pan-tilt fan system. (a) The dimension of the pan-tilt fan unit; (b) activated and resting fan unit; (c) Time measure for wind generation process.	12
Figure 5: Top-down view of the fan-unit layout. The white triangles are at lower level and the grey triangles are at higher level, and hang upside down.....	13
Figure 6: The map of main hardware connections. (1. USB wires; 2. Signal wires; 3. Power wires)	14
Figure 7: Wind module software architecture	15
Figure 8: Wind module visualization.....	16
Figure 9: Movement wind calculation	17
Figure 10: Floor vibration module actuator layout.....	18
Figure 11: Connection map of the floor vibration module. All the cables shown are audio signal cables.	18
Figure 12: Floor Vibration Module Software Architecture	19
Figure 13: Vibration Visualizer	19
Figure 14: View of the rings from the start location. The dotted lines and numbers are added here for clarity, and were not shown during the experiment.	20
Figure 15: Triangle Path Layouts.	23
Figure 16: Visualization of performance measures for the Triangle-completion Task.....	25
Figure 17: Path Visualizations of Individual Trials. They visualized relatively good (left) and bad (right) task performance.	27
Figure 18: Path visualizations of trials grouped by conditions and layouts. The left grouped path visualization is with condition FV+FS, and the right grouped path visualization is with condition MW.	27

Figure 19: Main effect of Footstep Vibration (FV) on Absolute Distance Error (DE) and Absolute Relative Distance Error (RDE).....	29
Figure 20: Subjective ratings for each of the eight questions in the main experiment.....	30
Figure 21: Subjective Measure Mean Value X Condition (Analysis I). Q8 Dizziness was removed since the value was reversed and there was no significant difference noticed.....	31
Figure 22: Interactions of MW×FS and FV×FS in Q3 Realism (Analysis II).....	33
Figure 23: Interaction of FV×FS in Q2 Walking (Analysis II)	34
Figure 24: Triangle Path Layouts.	36
Figure 25: Homogeneous means of conditions on Q7 Helpfulness.....	38
Figure 26: Interactions of DW×MW in Q4 Presence and Q7 Helpfulness.....	39

List of Tables

Table 1: Design space of sensory cues. Cells contain examples for the given category. The cues used in our work are in BOLD CAPITALS . (AC: Air-conditioner).	2
Table 2: The cues studied in the related works in the design space.	5
Table 3: There were a total of eight experimental conditions, shown within the gray region.	22
Table 4: We asked participants to rate each of the conditions based on the following eight questions.....	25
Table 5: Mean (M) and Standard Deviation (SD) values for all eight conditions on objective measures	28
Table 6: The results of Analysis II on the subjective measures (Experiment 1) ..	33
Table 7: Experimental Conditions.	36
Table 8: The results of Analysis II on the subjective measures (Experiment 2) ..	38

1 Introduction

Human beings experience the world through different sensory channels, i.e., we see, hear, touch, smell, and taste, etc. It stands to reason that we should experience virtual worlds in the same manner, where we are convinced to be occupying another space with the help of various sensory cues. Multi-sensory feedback has been proven to increase immersion in Virtual Environments (VEs), and it has great potential to be effective in many other aspects [28]. However, it is complicated to study the effect of multi-sensory feedback as a single factor, as the effects are mixed, depending on various cue types and tasks. A design space is thus needed to categorize the sensory cues in a more generalized way, and into an appropriate granularity.

1.1 Design Space of Multi-Sensory Cues

Multi-sensory feedback can first be grouped according to the five human senses, i.e., visual, auditory, haptic, etc., a common approach in virtual reality (VR) research [23]. Each group may or may not be further subdivided due to the nature of the sensory channel. For instance, the haptic group can be subdivided into kinaesthetic and tactile cues [3]. The former can be perceived from sensors in muscles, joints, and tendons, while the latter can be perceived cutaneously.

As shown in Table 1, we can group the multi-sensory cue types not only based on sensory channels (the left two columns), but also based on their use (remaining columns), i.e., ambient, object, movement, and informational cues.

- **Ambient Cues:** Ambient cues provide a natural atmosphere surrounding the user, and they can be hard to identify. Ambient light and city-street noise are two examples in the visual and auditory domains, respectively.
- **Object Cues:** Object cues come from specific objects placed in the scene. For example, when an air-conditioner is placed on the ground in a VE, the user can see it, hear the hum sounds, feel the airflow coming from its

source, and feel the floor vibration within a certain distance from it. These are considered object cues in the visual, auditory, and haptic channels.

- **Movement Cues:** Movement cues are provided based on the user’s motion. For example, when we walk, we can feel and hear the air moving past our ears.
- **Informational Cues:** Informational cues provide indications of additional information to the user. For example, when the user is approaching the boundary of the VE, floor vibration could serve as an alert for proximity.

Table 1: Design space of sensory cues. Cells contain examples for the given category. The cues used in our work are in **BOLD CAPITALS**. (AC: Air-conditioner).

Senses	Cues	Ambient	Object	Movement	Informational
Visual	General	Ambient Light	Visual Landmarks	Visual Flow	Information Panel
Auditory	General	City-street Noise	AC Hum	FOOTSTEP SOUNDS	Audio Instructions
	Wind	Atmospheric Wind	AC Airflow	MOVEMENT WIND	DIRECTIONAL WIND
Haptic	Floor Vibration	Factory-floor Vibration	Floor-type AC Vibration	FOOTSTEP VIBRATION	Proximity Alert
	Other	Atmospheric Heating	Object Collision Vibration	Vehicle Seat Vibration	Directional Vibration Indication
Olfactory	General	Smell of the Sea	Fruit Smell	N/A	Rosemary Indicating CO
Gustatory	General			N/A	

To better illustrate these, we provide examples for both the visual and haptic senses in a given situation. Imagine a user in a virtual city, surrounded by environmental light and wind, which are ambient cues. As she moves, she sees visual flow and feels air moving past her body, which are movement cues. When she arrives at a factory, the buildings and vibrating machinery provide object cues. If she wants to find her way through the space, a virtual compass on the screen or a directional vibration belt she may wear could be used to provide informational cues that can indicate directions. Some of the examples shown in Table 1 can be

found in [8] and [35]. From the generalized design space, we selected certain cues for a focused study, as an exploration.

1.2 Our Work

Travel is a fundamental task in VEs [3], and walking is one of the most commonly used types of travel (see, for example, first-person games). While physical walking is intuitive and can make people remain oriented with little cognitive effort [29], using it in VEs incurs technical and perceptual challenges [13]. Furthermore, it induces fatigue. An alternative method is to move in the VE using walking simulation, or non-fatiguing walking, that requires little accumulated physical exertion. The cost includes the loss of spatial orientation, self-motion perception, and overall presence, compared to physical walking. The main key factors that can help maintain the above, on a perceptual level, include field of view (FoV), motion cues (e.g., peripheral vision and vestibular cues), and multi-sensory cues (e.g., auditory and tactile cues). While the first two have been fairly thoroughly studied, the use of multi-sensory cues still remains open [3, 31].

In our study, we chose certain types of tactile cues from the design space, and investigated their effects in our VR setup, a non-fatiguing walking system, with a wide FoV, and vestibular, visual, and auditory cues enabled. We wanted to see whether a user’s navigational performance and experience could be further enhanced when multi-sensory cues are introduced, or whether there would be negative effects due to multi-sensory interactions [3]. Based on the potential to aid spatial orientation, self-motion perception, and overall presence during non-fatiguing walking, we originally chose two tactile cues to study, movement wind (MW) and footstep vibration (FV). Since these movement cues are akin to our real world experience, we wanted to see how effective they are in the virtual world through simulation. We also chose one auditory cue, footstep sounds (FS), to study the multi-sensory interaction. Due to participant feedback in the first experiment, we conducted a follow-up experiment studying the effect of an informational tactile cue, directional wind (DW).

We had the following hypotheses about the effect of tactile cues selected in our study. H1.1 and H1.2 were on MW and FV, based on which we designed Experiment 1. Due to the participants' requests for DW in Experiment 1, we designed a follow-up experiment that examined H2.1 and H2.2.

H1.1: Adding tactile cues (MW and FV) will enhance spatial orientation task performance.

H1.2: Adding tactile cues (MW and FV) will improve user experience during non-fatiguing walking.

H2.1: DW will improve task performance over conditions where it is not present.

H2.2: DW will improve user experience over conditions where it is not present.

1.3 Contributions

First, we created a design space to categorize multi-sensory cues for exploration. Second, we developed and described a full-stack immersive multi-sensory VR system which will be helpful for future researchers to replicate. Third, through rigorous user studies, we showed that tactile cues significantly improved user experience in VEs, and that footstep vibration in particular can also help maintain spatial orientation. We believe these insights will help future researchers and developers to choose multi-sensory cues more appropriately for their walking simulations.

The rest of the thesis is organized as follows. We present a detailed account of relevant earlier work in Section 2. Section 3 presents the development of our VR system, which was our experimental platform. Section 4 presents the empirical method, including two user studies and their analyses. In Section 5, we conclude by pointing towards future research directions.

2 Related Work

In this section, we establish related work by listing and discussing the studies on the secondary cues that we selected, i.e., wind and vibrotactile-enhanced footstep simulation, and the studies on path integration (PI), i.e., a measure for spatial orientation in VR.

2.1 Selected Secondary Cues in VR

The related works studying wind and footstep vibration are listed, followed by a discussion of the types of sensory cues selected, the effects studied, and the issues found about implementation. In particular, the sensory cues studied were fit into our design space (Table 1 and Table 2).

Table 2: The cues studied in the related works in the design space.

Cues	Ambient	Movement	Object	Informational
Wind	WindCube [24]	Sensorama [12]		
	Wind&Warmth [14]	VR Scooter [10]	Wind&Warmth [14]	WindWalker [9]
		Virtual Sailing [39]		
Footstep		KKE [36]		
Vibration		Plantar [37]		
Other				
Vibration		Sensorama [12]	VR Scooter [10]	

2.1.1 Wind in VR

Various displays have been developed and studied for generating wind cues for different uses. In the 1960s, the first wind display providing movement wind cues for VR was integrated in Sensorama [12], a motorcycle simulator. More systems and studies about wind in VR have been created more recently. The WindCube [24] used 20 fixed fans positioned around and close to the user to provide ambient wind cues. The study indicated enhanced presence by adding wind to a visual-only pre-computed snowstorm scene. The Head-mounted Wind system [6], using a group of fans mounted on a wearable framework, explored the portability of fan units and examined direction estimation error. The VR Scooter [10] was a virtual

locomotion device equipped with movement wind cues produced by a fan. The authors found that wind feedback indicating user movement, together with vibration feedback indicating collisions, improved user performance by providing more accurate sensations during motion. In other work, a wearable device [16] was developed by using an audio speaker and tube air delivery, and a two-point threshold experiment was conducted to find out the wind-sensitive parts of the head. WindWalker [9], providing informational wind cues for guidance, was head mounted, and was used as an orientation tool to indicate free paths when users were traversing a virtual maze blindfolded. Other work [17] created an atmospheric display with a wind tunnel to approximate natural airflow. The sense of presence of Virtual Sailing [39] was also enhanced by movement wind cues based on sailing speed and direction. A system simulating experiences such as a volcano scene [14] provided both ambient and object wind cues with a group of fixed fans. Some trends were found on the effect of wind and warmth on presence enhancement.

In the cited works that included empirical studies, various cue types were generated for different study purposes. Movement wind was mostly studied [10, 39], followed by ambient [14, 24], object [14] and informational wind [9]. The study purposes included examining the effects on perception enhancement, user experience, and performance. The existing studies on user-experience enhancement were limited to vehicle scenarios [10, 39], while our current work is interested in walking situations. There are existing studies about navigation performance [9, 10], but none of the studies was on spatial orientation, which we focus on here.

There are various ways of implementing wind displays. Fan sets are most commonly used [6, 10, 14, 24, 39]. Other implementations include using an air compressor [32], a controllable vent [17], and an audio speaker [16]. Due to the noise produced, the bulkiness of the air compressor and vent, and the limited wind coverage generated by the audio speaker approach, we chose fan sets in our study. However, one of the main drawbacks of existing fan systems is latency [14],

meaning the delay from the moment the wind is triggered in the VR software component until the user feels the wind. This is mainly caused by the time it takes the fan motor to spin up to speed. More immediate wind feedback onset based on user movement using fans is thus hard to implement and study. Similar problems exist in terms of removing the wind sensation, as fans take time to slow down. In our study, this on/off latency issue was solved by making the fan spin all the time on a pan-tilt platform, which we can quickly point towards and away from the user.

2.1.2 Vibrotactile-enhanced Footstep Simulations in VR

Another potential aid to user experience and performance during non-fatiguing walking in VR is the simulation of footsteps. Cues for this are a combination of movement cues across multiple sensory channels, i.e., visual (head bob), auditory, and vibrotactile during virtual movement, while the user is not physically walking.

Early studies have shown that camera motion can improve presence in walking simulations [19] and synthetic footstep sounds enhance the sensation of walking [25]. Recent studies have shown the great potential of vibrotactile cues to further enhance user experience [25, 38]. In the study of King Kong Effects [36], vibrotactile tiles were put under the user's feet, and a clear preference for the combination of visual and vibrotactile cues was suggested in terms of walking sensation. Another study using plantar vibrotactile cues in a non-immersive environment [37] found that walking realism was further improved when the auditory cues were combined with vibrotactile cues, regardless of whether or not there were visual cues.

While these studies on user-experience enhancement were based on desktop systems [36, 37], we were curious about the effects in immersive VEs. Similar to wind studies on performance, to the best of our knowledge, there are no existing studies about the effects of footstep simulation on spatial orientation in VR.

2.2 Path Integration in VR

One of the commonly used tasks to measure spatial orientation in real environments is path integration (PI), which is a standard, well-defined navigational test in the real world, and has been extended to VR [21]. The user first travels along a path consisting of multiple segments, then is asked to return to the origin without seeing the travelled path or starting point. Vestibular and proprioceptive cues were shown to have positive effects [7, 15]. Other studies were focused on the effect of visual cues and the results were mixed. Visual display size was proven to affect performance, i.e., physically large displays led to better performance in PI [34]. People performed better in 2D environments than in 3D. People being shown a map prior to the task performed worse than those who were not shown the map, which was counterintuitive [2]. Geometrical field of view did not affect performance [27]. Visual and audio immersion had no significant effect either [30]. On the other hand, path properties in PI, such as the number of segments, path layout, and homing distance [40], were shown to affect performance significantly. In our study, we examined whether certain secondary cues would allow the user to perform better at PI, i.e., to better maintain spatial orientation, in HMD-based VEs, and during non-fatiguing travel, where vestibular and proprioceptive cues are only partially present.

3 System Implementation

To study the effects of selected tactile cues on both user experience and spatial orientation during non-fatiguing walking in VEs, we developed a multi-sensory immersive VR system with tactile feedback including wind and floor vibration, using a modified version of the ChairIO travel technique [1]. The system was designed based on two themes in our study. First, we devised a low-latency solution to control the wind speed and direction based on changes in user motion, and floor vibrations for simulating user footsteps in VR [11]. The system is thus able to deliver tactile cues in the experiments. Second, instead of holding devices, standing, pointing, or physically walking around, the modified ChairIO technique enables the user to sit on a chair, swivel to rotate, and travel by leaning the upper body. With such a design, we preserved key factors already known that can contribute to non-fatiguing walking experience and performance in our experiments, including wide FoV, and vestibular, visual, and auditory cues.

3.1 Physical Layout

Figure 1 and Figure 2 show a schematic layout of the physical space and the components of our system. We created a cage-like setup for the hardware components, and the user was positioned at the center of the cage. In the cage, the user was asked to sit on a Swopper Chair [33], transformed into a motion-control input device using a B-Pack Compact Wireless Accelerometer (Model WAA-001). The user wore an Oculus Rift DK2 head-mounted visual display, which included a head-orientation tracker (without positional tracking). This setup enabled the user to *walk around* in the virtual scene by leaning to control the pitch and roll of the chair using her body, and to look/hear around by swiveling her chair and head.

A noise-cancelling headset (Bose QuietComfort 15) was used for audio rendering. The user was surrounded by eight pan-tilt fan units mounted on the 2.5m diameter octagonal frame of the cage for wind cues, and four low-frequency vibration actuators mounted under a raised floor for vibration cues.

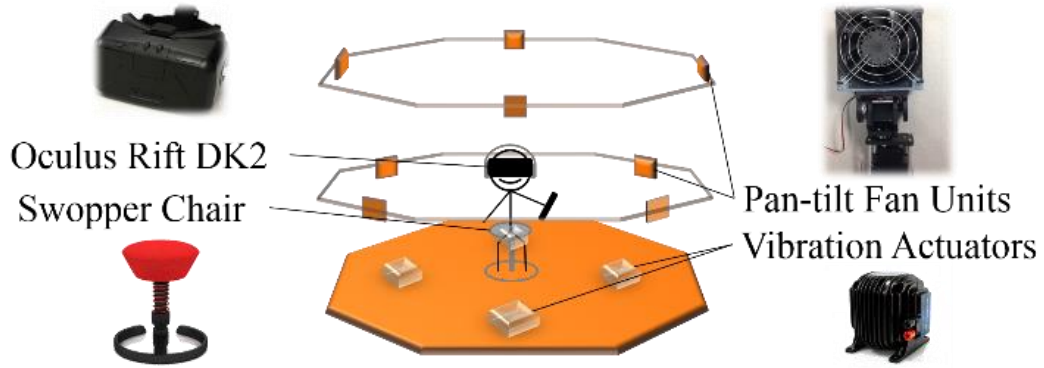

Figure 1: The primary components of our VR system



Figure 2: The view through Oculus Rift (left) and lab setup (right)

Figure 3 shows the system architecture. The simulation (Sim), with a virtual scene in it, based on Unity3D, is the core of system input and output control. The user input is received from the accelerometer on the chair and the orientation sensor from the DK2. The visual and auditory outputs are sent from the Sim to the DK2 display and the audio headset. The Sim also produces the necessary commands that are sent to the wind and floor vibration subsystems, which convert the commands into control of the physical feedback devices.

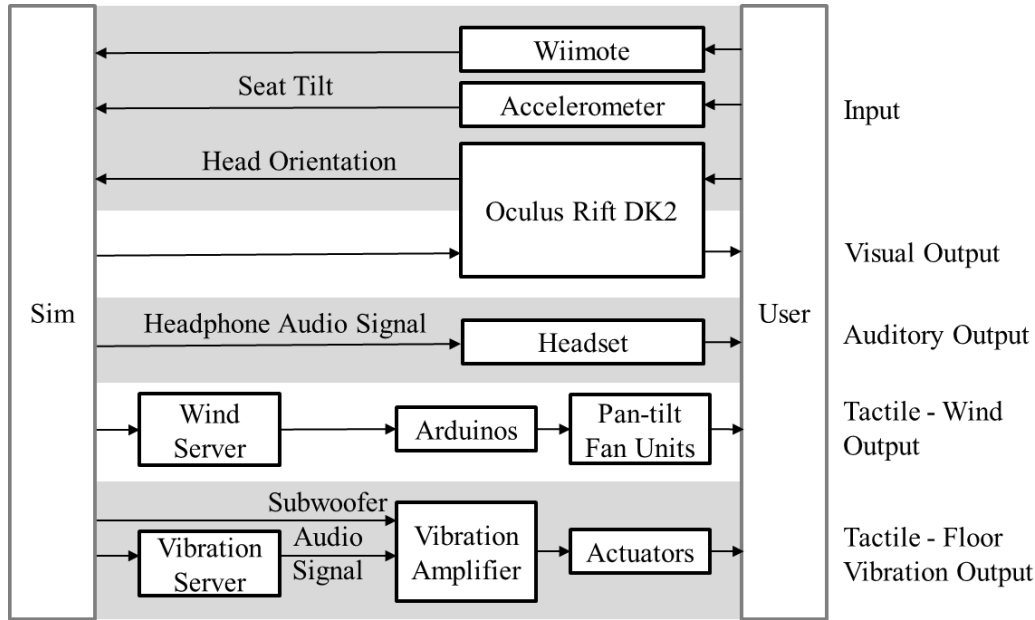

Figure 3: System architecture

3.2 Wind Module

The wind module is a group of pan-tilt fan units controlled by two Arduinos connected to the Wind Server through USB. The software running on the server receives commands from Sim, and manipulates the firmware and hardware to provide wind feedback to the user.

3.2.1 Hardware and Firmware

3.2.1.1 Pan-tilt Fan Unit

Eight pan-tilt fan units are installed in the cage. Each fan unit (Figure 4a) has a 120mm DC fan (Delta AFB1212SHE-4F1C) mounted on a pan-tilt platform controlled by two servomotors. Wind speed of each fan is controlled over a range from 0 (off) to 255 (MAX, or 4 m/s measured at a distance of 50 cm).

By using the pan-tilt fan unit instead of a fixed fan, we were able to reduce the latency of wind feedback, mainly caused by fan motor speed changes, reported with previous wind systems [14]. To address the significant lag, the fans on our pan-tilt platforms always spin at a minimum level of 100, but are turned away from the user when the wind should be still, and can quickly be turned

towards the user and spun up when needed. We did a frame analysis using 30 fps video capture, to measure both the fixed and pan-tilt fan systems. We simulated the fixed-fan system by fixing the fan toward the user. As shown in Figure 4c, in our system, the end-to-end dataflow of wind delivery is from the user trigger (leftmost) to user perception (rightmost), where the Sim and Wind Server were running on the same PC. It took an average of 0.37s from software trigger to the fans. However, it took the fixed fan 3.53s to start generating wind from zero, but only took 0.33s for the pan-tilt fan unit, which was already spinning at a lower level, to turn to the user. With such a design, near-instant movement wind feedback can be applied or removed (Figure 4b).

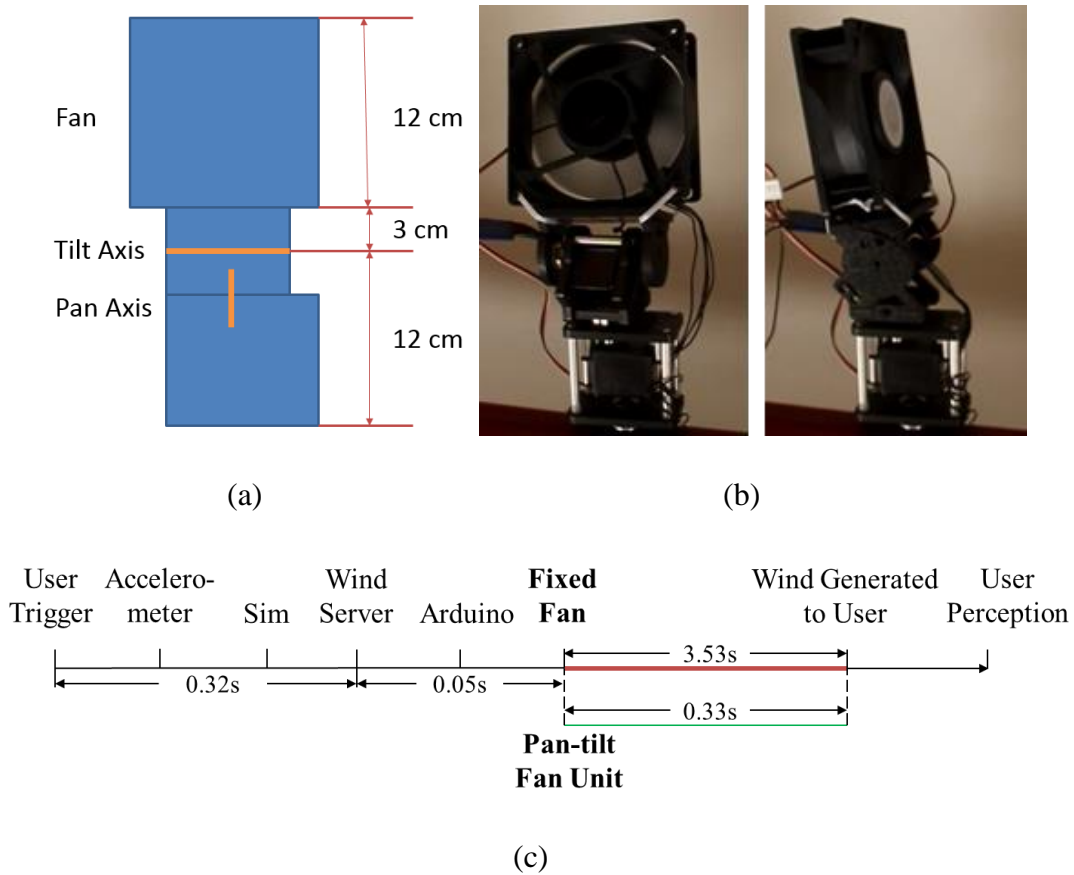

Figure 4: Pan-tilt fan system. (a) The dimension of the pan-tilt fan unit; (b) activated and resting fan unit; (c) Time measure for wind generation process.

3.2.1.2 Fan Layout

A top-down view of the fan-unit layout is shown in Figure 5. The eight units are divided into two groups, four are installed at a lower level (0.85m above the ground) while the others are mounted upside down at a higher level (1.9m).

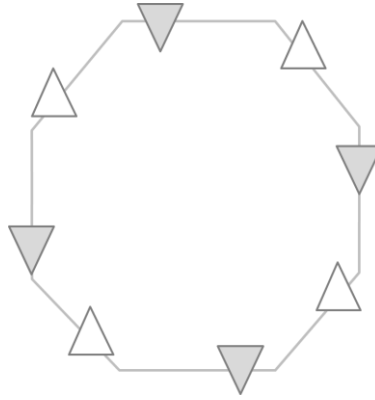

Figure 5: Top-down view of the fan-unit layout. The white triangles are at lower level and the grey triangles are at higher level, and hang upside down.

3.2.1.3 Connection Map

Each fan unit also belongs to one of two *Wind Sets*, each of which consists of hardware and firmware, and controls up to five fan units. The figure below shows the connection map, including a detailed structure of one *Wind Set*.

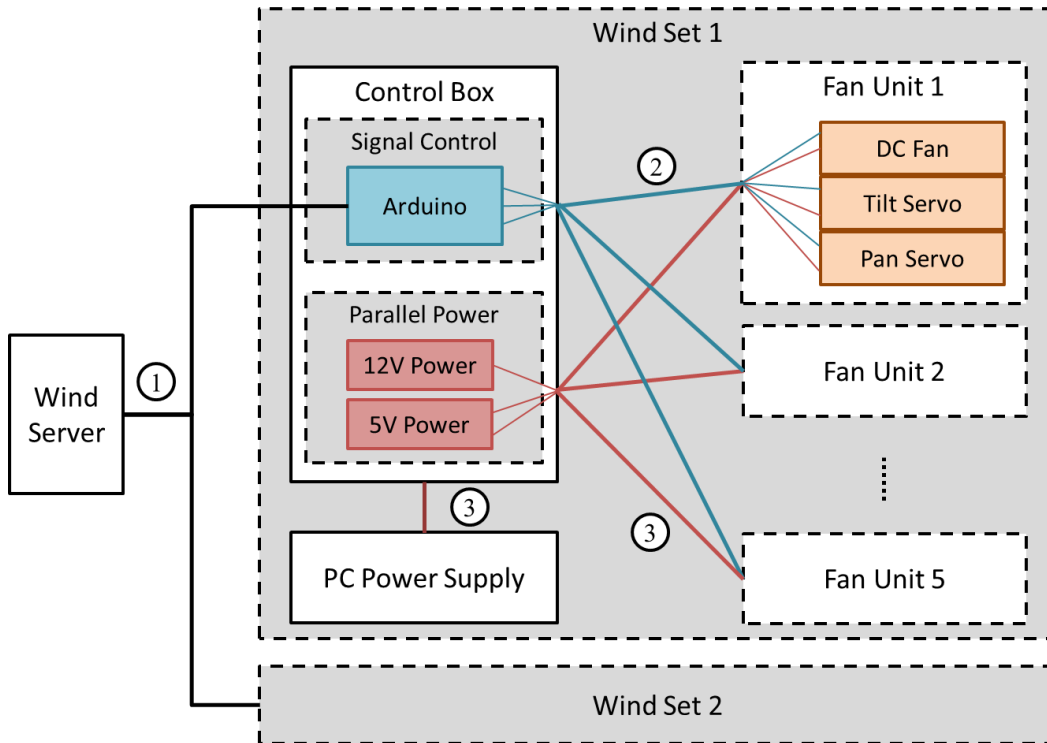

Figure 6: The map of main hardware connections. (1. USB wires; 2. Signal wires; 3. Power wires)

3.2.2 Software

The wind module software is a control program installed on the wind server (Figure 7). It has four main parts:

- **Socket Connection:** Receives commands sent from VR Sim through User Datagram Protocol (UDP). The commands carry information including real-time user position and rotation in the VE, as well as in the physical space if supported by the tracking system. (See Appendix A for the communication protocol)
- **Wind Calculator:** Parses the received commands and calculates appropriate hardware-control level commands.
- **Wind Manager:** Takes the calculated commands from the Wind Calculator and sends them to the Arduino board, so as to control the corresponding fan units. Logically, it manipulates each fan unit directly according to a hardware mapping configuration file. With such a design, the hardware can be connected with flexibility.

- **Wind Visualizer:** Visualizes the physical space and the wind generated from each fan unit.

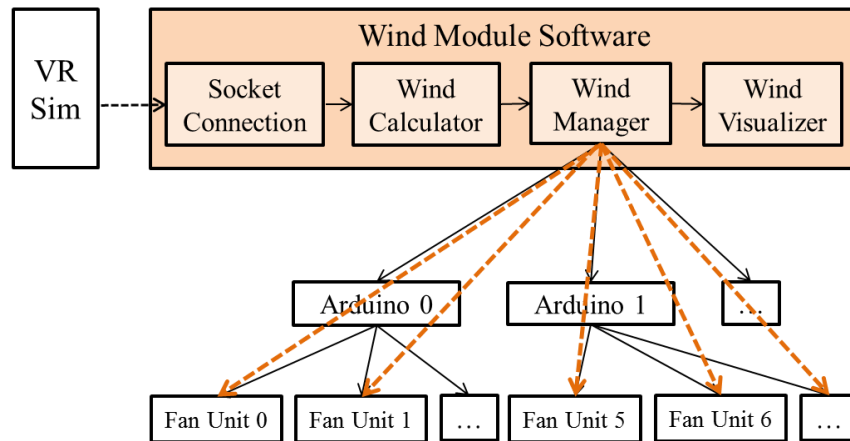

Figure 7: Wind module software architecture

3.2.2.1 Wind Visualizer

The Wind Visualizer displays the real-time state of the physical space, including the user, fan units, and the wind generated. As shown in Figure 8, a green wireframe box represents the cage, in which there is a cyan wireframe box representing the user in the visualization window. From each pan-tilt fan unit mounted in the cage, a cyan line indicating the wind generated with corresponding speed (mapped to the length of the line) and direction is drawn.

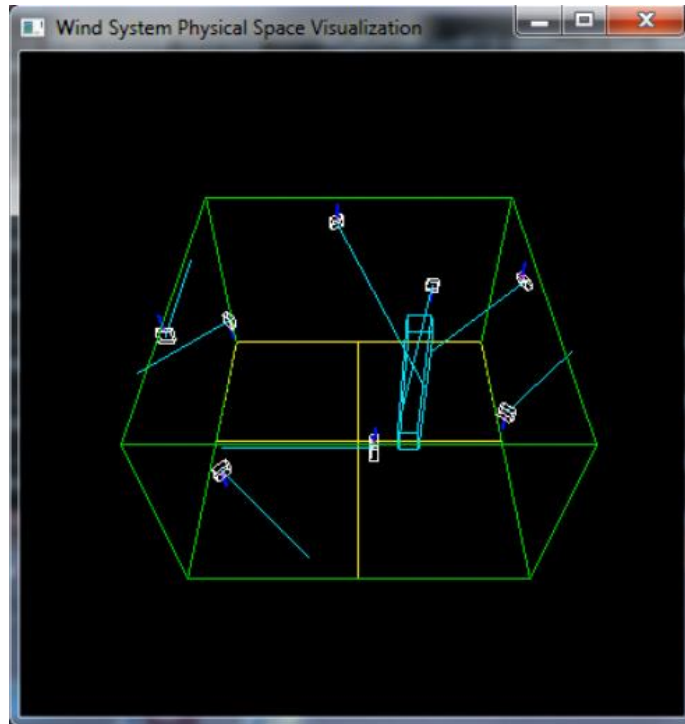

Figure 8: Wind module visualization

3.2.2.2 Wind Calculator

The Wind Calculator can calculate three types of wind cues in the design space (See Section 1.1), movement wind, object wind, and directional wind.

Movement wind is calculated based on the user's motion direction and speed (Figure 9). Certain fan units within range turns toward the user, blowing with a weighted wind speed. Directional wind is generated in a simpler way. Three adjacent fans are selected and pointed at the user, blowing with smoothly varying speed within the range [100, 255]. Object wind generates wind within a specified range, in the shape of a cone, though we did not use it in the current studies.

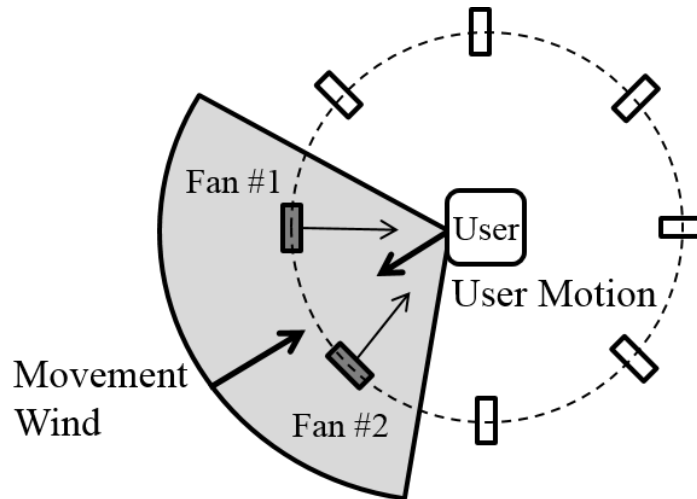

Figure 9: Movement wind calculation

3.3 Floor Vibration Module

Similar to the Wind Module, the Floor Vibration Module receives commands from the VR simulation and sends the calculated audio signals to a group of low-frequency audio actuators to generate floor vibration.

3.3.1 Hardware

The hardware control of the floor vibration module is implemented by sending calculated audio values (frequency and amplitude) by control software, then through an amplifier to a group of low-frequency audio actuators (Buttkicker LFE units [4]) installed under a raised floor to generate floor vibration. Alternatively, a mono audio signal can be sent directly to the amplifier from the VR simulation, bypassing the Vibration Server. This latter approach was used in our experiments, using the subwoofer channel of our 5.1 audio system.

3.3.1.1 Actuator Layout

A group of four actuators is installed under the raised floor, as shown in Figure 10.

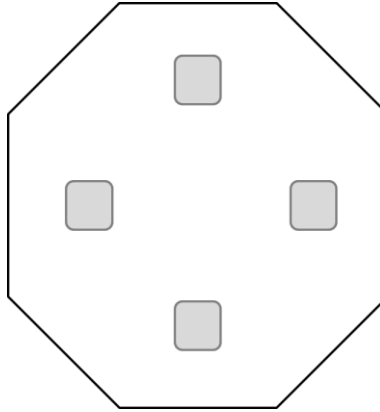

Figure 10: Floor vibration module actuator layout

3.3.1.2 Connection Map

Figure 11 shows the connection map of vibration hardware.

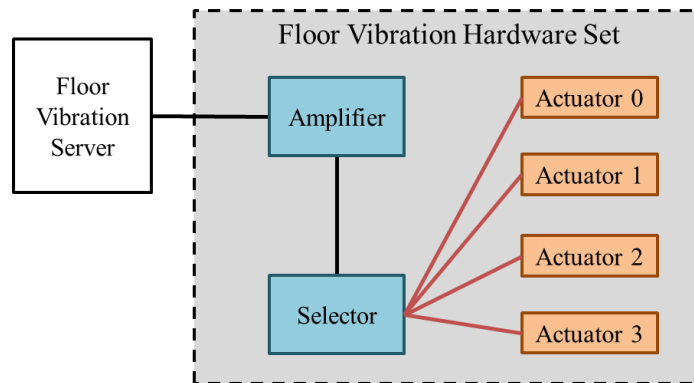

Figure 11: Connection map of the floor vibration module. All the cables shown are audio signal cables.

3.3.2 Software

The floor vibration module software is a control program installed on the floor vibration server (Figure 12). Similar to the wind module, it has four main parts:

- **Socket Connection:** Receives commands sent from VR Sim through UDP. (See Appendix A on the communication protocol)
- **Vibration Calculator:** Parses the received commands and calculates appropriate hardware-control level commands.
- **Vibration Manager:** Takes the calculated audio frequency and amplitude from Vibration Calculator and sends them to the amplifier.

- **Vibration Visualizer:** Visualizes the audio amplitude and frequency of current state through an oscillograph. (Figure 13)

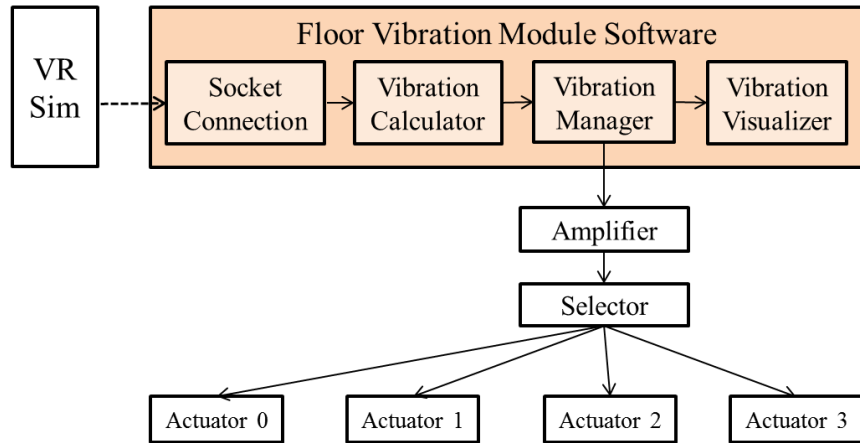

Figure 12: Floor Vibration Module Software Architecture

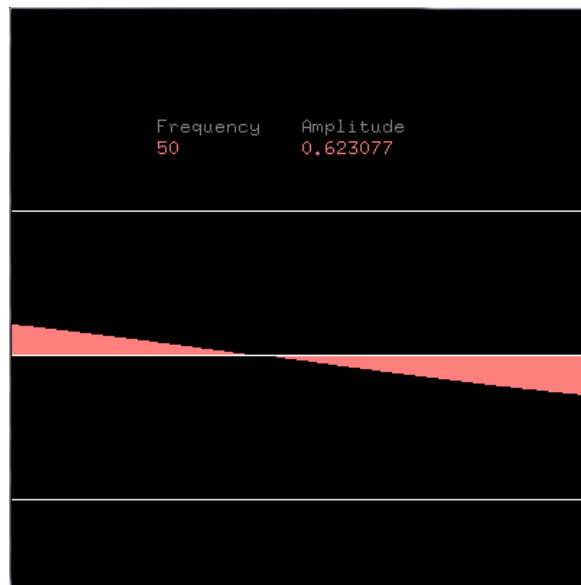

Figure 13: Vibration Visualizer

4 Empirical Study

We ran two user studies using our VR system, one main experiment and one follow-up experiment, to evaluate the effectiveness of the selected tactile cues in isolation and combination, on user performance and experience during walking. We studied three tactile cues, movement wind, footstep vibration, and directional wind, as well as another cue, footstep sounds, for the study of interaction.

4.1 Experimental Task

The task used in both experiments was a triangle-completion task, which is one form of a path integration task to measure the user's spatial orientation in VR [21] (Figure 14). In the task, there were three rings (radius = 4m) in the scene, and the participant was first positioned at the center of the first ring, with the second and third rings in sight. The participant was asked to move to the second ring, then to the third ring. Each successive target ring was highlighted. As soon as the participant reached the third ring, all of the rings disappeared and she was asked to return to her initial position in the first ring.

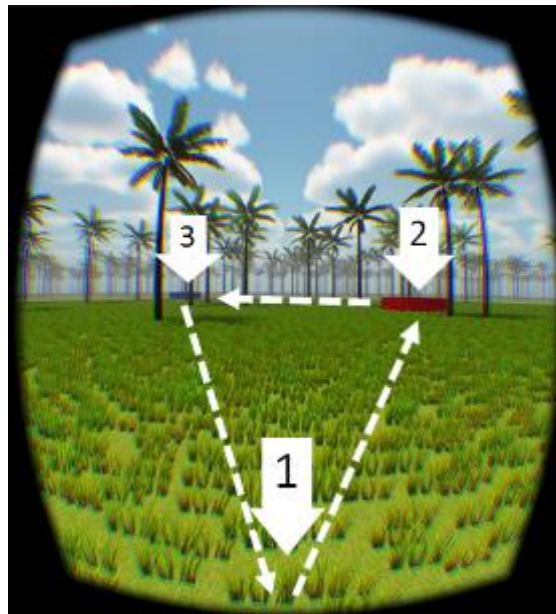

Figure 14: View of the rings from the start location. The dotted lines and numbers are added here for clarity, and were not shown during the experiment.

4.2 Experiment 1: Movement Wind, Floor Vibration and Sound

The focus of this experiment was to evaluate the effects of movement wind, footstep vibration, and footstep sound on performance of the triangle-completion task, as well as the overall user experience.

4.2.1 Experimental Design

We designed a within-subjects experiment, which enabled us to reduce error variance associated with individual differences. All trials included visual and ambient audio feedback. There were eight combinations of the three independent variables, with/without Movement Wind (MW), with/without Footstep Vibration (FV), and with/without Footstep Sounds (FS), and each participant was exposed to all eight conditions (Table 3).

Overall, there were five independent variables in this study.

- **Movement Wind Cue** \in {On, Off}

A velocity-proportional wind was either blown or not towards the participant based on her movement in the VE.

- **Footstep Vibration Cue** \in {On, Off}

The floor of the system on which the participant placed her feet was either vibrated or not based on her footsteps. We provided a pair of sandals with thin soles and asked participants to wear those during the experimental sessions. This helped eliminate any error due to the differences in sole thickness of various shoes, which may have affected the perception of floor vibration.

- **Footstep Sound Cue** \in {On, Off}

The sound of footsteps was either rendered or not based on the participant's footsteps during movement in the VE.

- **Triangle Path Layout** \in {Path 1, Path 2, Path 3, Path 4}

We used four different paths in this study. Each of these paths was used in every condition for all participants. The paths were carefully designed to reduce repetition and learning effects. The length of the first side, of the second side, and the angle between the first and second sides for each of

the paths were as follows: Path 1 (90m, 51.96m, 90°), Path 2 (103.92m, 60m, 90°), Path 3 (103.92m, 103.92m, 60°), Path 4 (60m, 60m, 120°)

- **Triangle Direction** \in {Clockwise, Counterclockwise}

To further reduce learning effects and to create variety in the travel task, we introduced the target rings in the VE in either a clockwise or counterclockwise layout.

The first three independent variables were the focus of this experiment, while the last two were designed with the purpose of variation and counterbalancing. Eight triangle path layouts, based on the last two variables, were used in the experiment (Figure 15). With each of the eight conditions, the participant went through four triangle path layouts, either group (a) or group (b). Thus, every participant experienced 8x4 triangle-completion trials. We counterbalanced the conditions using an 8x8 Latin-square. We further counterbalanced the paths using a 4x4 Latin-square and alternated between clockwise and counterclockwise in each successive trial. Overall, we collected $8 \times 4 \times 24 = 768$ data points in the whole experiment.

Table 3: There were a total of eight experimental conditions, shown within the gray region.

		FS			
		Yes		No	
		FV		FV	
		Yes	No	Yes	No
MW	Yes	ALL	MW+FS	MW+FV	MW
	No	FS+FV	FS	FV	NONE

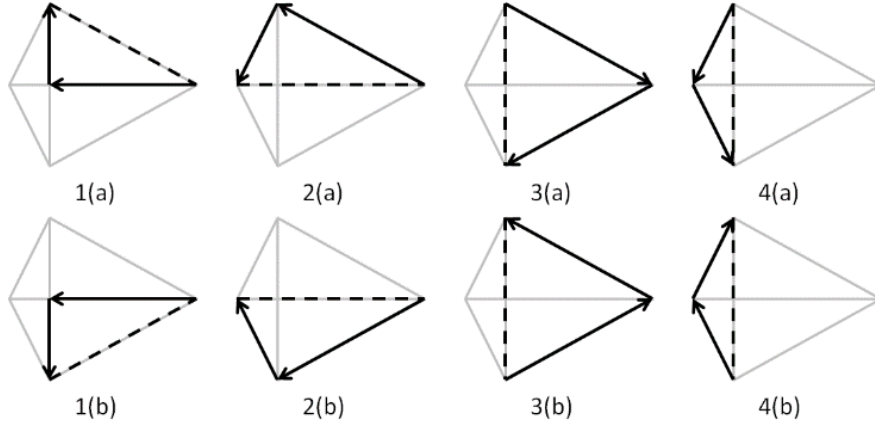

Figure 15: Triangle Path Layouts.

4.2.2 Procedure

Before the experimental task, each participant signed an IRB-approved consent form, and filled out a demographic form indicating age, gender, handedness, and experiences related to video games and VR. We used the Gilford Zimmerman orientation survey (GZ test) [18] as a pre-test to measure spatial orientation ability in VR.

During the experimental task, participants could look and move around within a flat-ground forest, where the trees were randomly planted. The VE was designed to make sure that the visual cues were randomly spread. All trees looked the same and we made sure that they were placed randomly in a way that participants could not use density or patterns of trees as cues for orientation.

Each participant first went through a training session, where she travelled freely in the environment and then completed equilateral triangles (side=50m), with all three rings shown, with and without the existence of all the independent variables. The participant was told to remember the perception of travelling through each 50m side as a base for distance estimation later in the actual experiment.

Then participants completed every trial under all of the conditions. At the end of each trial, we asked participants the length of distance units she travelled. After each condition section, she filled out a subjective questionnaire (Table 4),

followed by a two-minute mandatory rest period. After the experimental task, we asked each participant to rank the different conditions, and tell us the strategies she applied.

4.2.3 Measures

Our measures included both objective and subjective ones.

4.2.3.1 Objective Measures

In order to measure spatial-orientation performance, the following dependent variables were defined (refer to Figure 16).

- **Signed Distance Error (DE)**: The difference in length between Edge 4 and Edge 3. A positive value means that the distance between the participant's Final Stop and Vertex 3 is longer than Edge 3.
- **Absolute Distance Error $|DE|$** : The absolute value of (DE).
- **Signed Relative Distance Error (RDE)**: The ratio of (DE) to Edge 3.
- **Absolute Relative Distance Error $|RDE|$** : The absolute value of (RDE).
- **Signed Angle Error (AE)**: The counterclockwise angle from Edge 3 to Edge 4.
- **Absolute Angle Error $|AE|$** : The absolute value of (AE).
- **Signed Distance Estimation Error (DEE)**: The difference between the participant's estimated distance travelled and the real distance travelled. A positive value means that the distance was overestimated.
- **Absolute Distance Estimation Error $|DEE|$** : The absolute value of (DEE).
- **Closeness**: The distance between Vertex 1 and Final Stop.

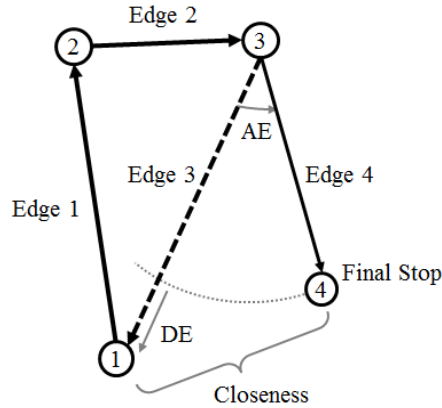

Figure 16: Visualization of performance measures for the Triangle-completion Task.

4.2.3.2 Subjective Measures

Subjective data were also collected to measure user experience. There was one questionnaire rating for each condition, which asked about the sense of presence and movement, etc.

Table 4: We asked participants to rate each of the conditions based on the following eight questions.

Question Number	Subjective Measure	Question (range: 1-6)
1	Movement Sensation	To what extent did you experience the sensation of movement?
2	Walking Sensation	To what extent did you experience the sensation of walking?
3	Realism	How close did the computer-generated world get to becoming like the real world?
4	Presence	To what extent were there times during the experience when the computer-generated world became the "reality" for you, and you almost forgot about the "real world" outside?
5	Presence	To what extent did you experience the sense of "being there" while you were travelling in the VE, as opposed to being a spectator?
6	Helpfulness	Please rate your sense of direction while you were travelling in the VE.
7	Helpfulness	Please rate the extent to which you think the feedback in this condition helped your performance of the task?
8	Dizziness	How much dizziness did you experience while performing the task in this condition?

As shown in Table 4, Q1-2 measured motion perception, Q3-5 measured the sense of realism and presence, Q6-7 measured cue helpfulness, and Q8 measured dizziness. Comments and a top-three ranking of the conditions were also collected at the end of the experiment

4.2.4 Participants

Twenty-four participants (21 male) took part in the experiment. Their ages ranged from 18 to 31 ($M=21$, $SD=3.58$). In their background reports, half of them played video games frequently, while five of them had immersive virtual reality experience. The score of the pre-test (GZ test) [18] was within the range from -9 to 47 ($M = 16.47$, $SD=14.9$).

4.2.5 Path Visualization

We collected data on the participant's travel path for each trial, including her position and orientation in VE for every 0.4 seconds. As shown in Figure 17, each visualization represents a top-down view of an individual task trial, and the first, second, and third rings are marked as green, red, and blue. The participant's path is visualized as a sequence of small triangles, the position and orientation of which corresponds to the position and orientation of the user at that particular moment. The color of the triangle ranges from black to green, which is mapped to the travel speed. The transparency of the small triangle is set to 0.5, so that multiple paths can be overlapped to examine the overall effect. In Figure 17, the left represents better performance than the right, where the participant hesitated in judging the correct location. In Figure 18, the paths of all the trials with the same triangle layout and experimental condition are overlapped so that the overviews of various conditions can be formed and observed (see Appendix B for all path visualizations grouped by triangle paths and conditions in the two experiments).

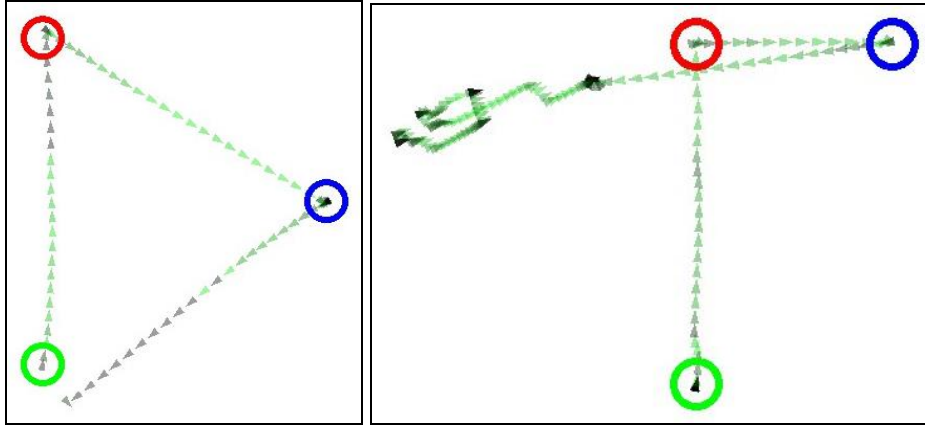

Figure 17: Path Visualizations of Individual Trials. They visualized relatively good (left) and bad (right) task performance.

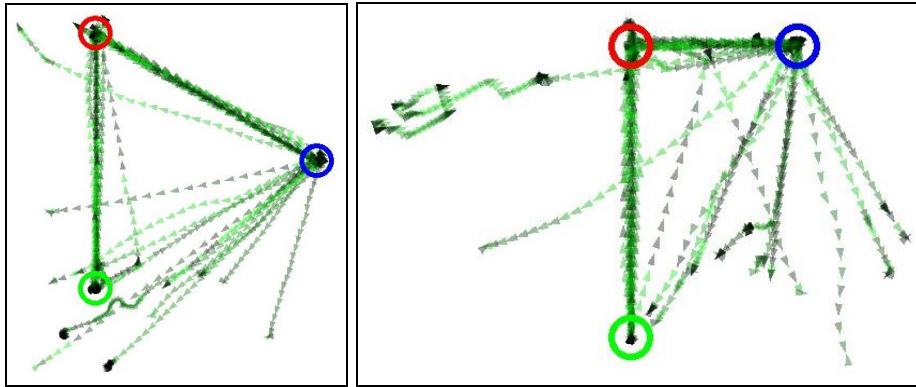

Figure 18: Path visualizations of trials grouped by conditions and layouts. The left grouped path visualization is with condition FV+FS, and the right grouped path visualization is with condition MW.

4.2.6 Results

In this section we present our results for the objective and subjective data. The data collected in the experiment were analyzed in SPSS v.21. Initially, we compared homogeneous means of the eight conditions by running one-way repeated measures ANOVA and Tukey's HSD post-hoc (*Analysis I*). Then, we examined the main effects and interactions of the three independent variables (MW, FV, and FS) by running 2x2x2 factorial repeated measures ANOVA (*Analysis II*). Other effects, such as the correlation between participants' GZ-test score and their real performance, were also analyzed.

4.2.6.1 Objective Data

From the results of Analysis I, when comparing homogeneous means of the eight conditions, we did not notice a significant effect on any of the objective dependent variables (Table 5).

Table 5: Mean (M) and Standard Deviation (SD) values for all eight conditions on objective measures

Objective Measures	Conditions							
	ALL	NONE	FS	FS+FV	FV	MW	MW+FS	MW+FV
DE (m)	14.5 (21.24)	15.4 (27.44)	12.3 (23.37)	13.4 (22.16)	13.0 (23.10)	10.1 (27.59)	-13.9 (22.94)	-13.2 (23.25)
DE (m)	21.3 (14.26)	25.5 (18.28)	22.4 (13.89)	20.1(16.3 2)	21.0 (16.08)	24.7 (15.74)	22.0 (15.21)	22.4 (14.47)
RDE	-0.1 (0.20)	-0.1 (0.26)	-0.1 (0.22)	-0.1 (0.21)	-0.1 (0.22)	-0.1 (0.26)	-0.1 (0.21)	-0.1 (0.22)
RDE	0.2 (0.13)	0.2 (0.17)	0.2 (0.13)	0.2 (0.16)	0.2 (0.15)	0.2 (0.15)	0.2 (0.14)	0.2 (0.13)
AE (°)	12.6 (32.92)	14.8 (29.86)	11.5 (31.75)	11.3 (31.10)	12.8 (30.59)	8.9 (29.29)	13.0 (30.57)	14.5 (30.64)
AE (°)	24.0 (25.72)	23.7 (23.42)	25.6 (21.89)	24.9 (21.65)	25.1 (21.59)	25.1 (17.38)	25.7 (20.97)	27.2 (20.05)
DEE (m)	14.3 (188.97)	17.4 (180.36)	29.9 (151.75)	29.7 (145.17)	10.9 (176.55)	22.2 (177.04)	-26.6 (120.73)	-19.6 (158.45)
DEE (m)	121.7(144 .77)	116.6(138 .22)	97.3 (119.85)	103.2 (106.0)	110.3 (137.82)	120.7 (130.88)	93.0 (80.96)	109.3 (115.82)
Closeness (m)	47.1 (30.58)	51.7 (30.27)	52.5 (30.03)	48.3 (30.04)	50.4 (30.39)	53.1 (26.44)	52.2 (34.5)	53.2 (29.08)

However, from the results of Analysis II, we noticed a significant main effect of Footstep Vibration (FV) on Absolute Distance Error (|DE|): $F(1, 23) = 7.27$, $p = 0.013$, $\eta_p^2 = 0.24$, and on Absolute Relative Distance Error (|RDE|): $F(1, 23) = 7.3$, $p = 0.013$, $\eta_p^2 = 0.24$ (Figure 19). |DE|, defined based on previous triangle completion studies [34], showed that the absolute distance error was 2.5 meters less in the trials with FV. |RDE|, which was the proportion of |DE| to the returning side of the triangle, revealed a normalized error, also showing that the error in the trials with FV was 2.3% lower.

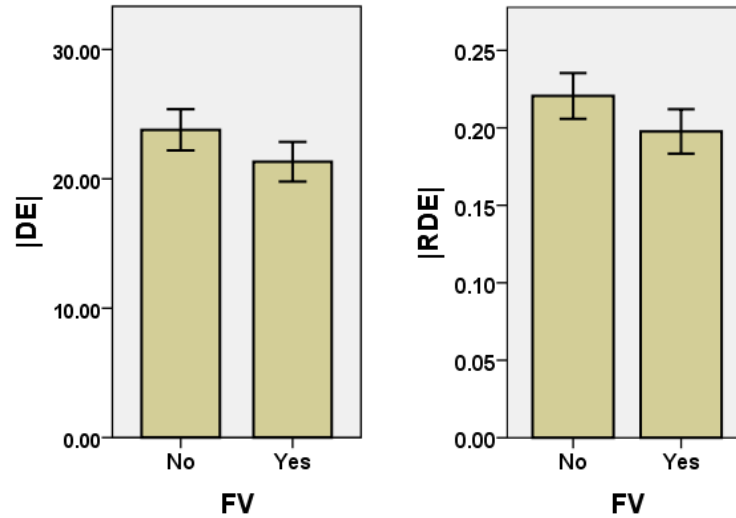

Figure 19: Main effect of Footstep Vibration (FV) on Absolute Distance Error ($|DE|$) and Absolute Relative Distance Error ($|RDE|$)

Among the other effects we examined, we found that overall, participants tended to underestimate their travel distance in the VE, although there was no significant difference between conditions. This is consistent with numerous earlier studies that report distance underestimation in VEs.

The correlation between performance and GZ-test score was analyzed. Among all the objective measures, we found that Absolute Distance Estimation Error (|DEE|) and GZ-test score were moderately positively correlated, $r(24) = 0.428$, $p = 0.037$. No significant correlation was found between GZ-test score and other objective measures.

4.2.6.2 Subjective Data

As shown in Table 4, we asked eight questions to participants after each of the conditions. From the results of Analysis I for each question, overall, we noticed a strong preference for the ALL condition and a strong disfavor for the NONE condition (see Figure 20). From a combined line chart view (Figure 21) of the subjective measures over the eight conditions, ordered to make the curves as smooth as possible, we notice a trend. The ratings increased with the number of cues involved. In addition, in conditions where FV was involved, the ratings tend to be higher, and have more impact.

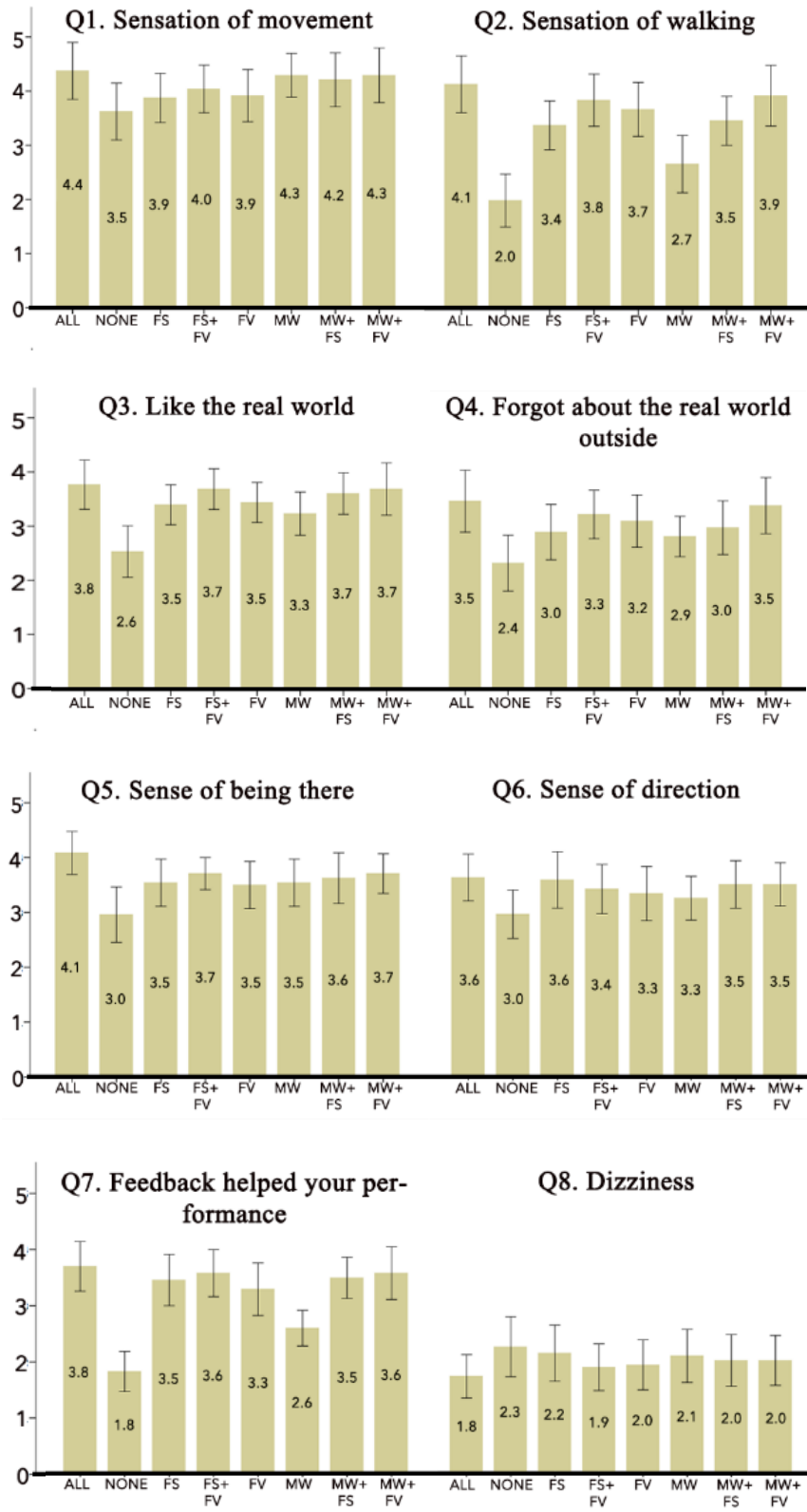

Figure 20: Subjective ratings for each of the eight questions in the main experiment.

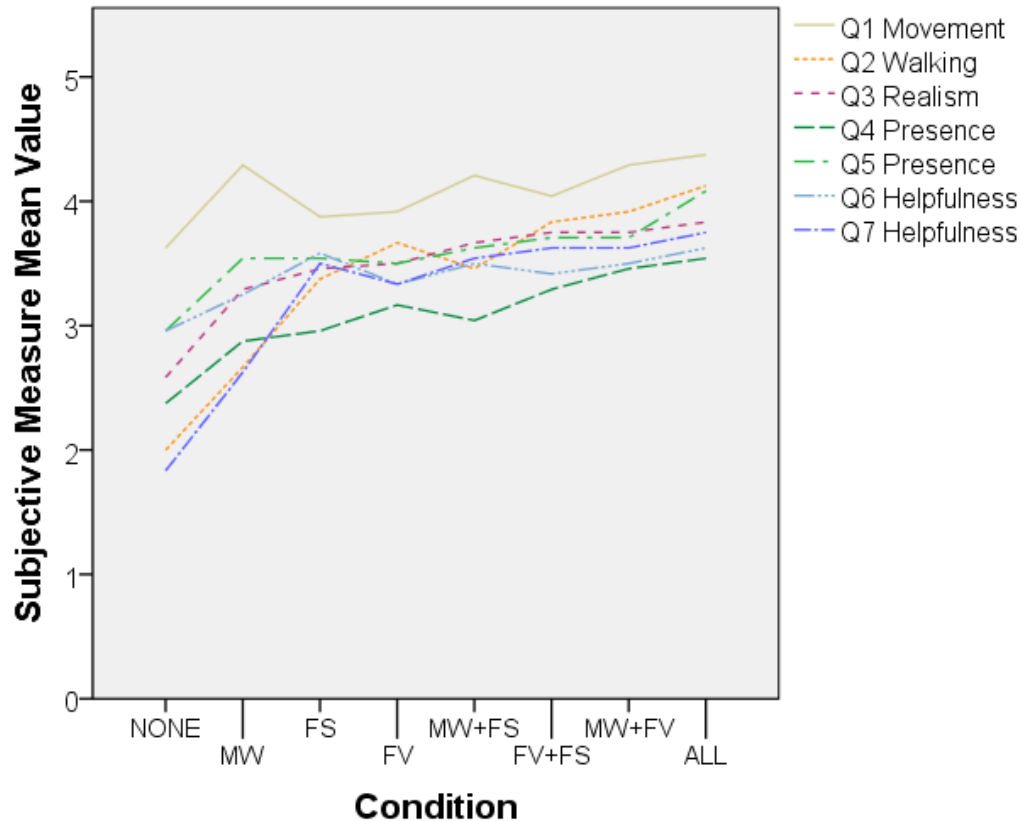

Figure 21: Subjective Measure Mean Value X Condition (Analysis I). Q8 Dizziness was removed since the value was reversed and there was no significant difference noticed.

The significant results of Analysis I are reported in detail as follows.

Question 1 (Movement): We found that the data did not meet the assumption of sphericity ($p = 0.002$). There was a significant difference between conditions $F(3.72, 85.63) = 2.57, p = 0.047, \eta_p^2 = 0.1$. Participants reported NONE to be the worst condition, which was significantly worse than MW ($p = 0.03$).

Question 2 (Walking): ANOVA showed a significant difference between conditions $F(7, 161) = 20.1, p < 0.001, \eta_p^2 = 0.47$. Overwhelmingly, the NONE condition was rated significantly worse than all other conditions ($p < 0.01$) except for MW. Condition ALL was rated significantly better than MW and NONE at $p < 0.001$. MW was significantly worse than ALL ($p < 0.001$), FS+FV ($p = 0.001$), FV ($p = 0.002$), and MW+FV ($p = 0.001$).

Question 3 (Realism): We noticed significant differences between conditions $F(7, 161) = 9.5, p < 0.001, \eta_p^2 = 0.29$. Condition NONE was significantly worse than all other conditions: ALL ($p < 0.001$), FS ($p = 0.03$), FS+FV ($p < 0.001$), FV ($p < 0.01$), MW ($p = 0.01$), MW+FS ($p = 0.001$), and MW+FS ($p < 0.001$). We did not find any other significant differences between other conditions.

Question 4 (Presence): In this question, we found a significant difference between conditions $F(7, 161) = 6.3, p < 0.001, \eta_p^2 = 0.22$. Condition NONE was significantly worse than ALL ($p = 0.02$), FS+FV ($p < 0.01$), FV ($p = 0.04$), and MW+FV ($p = 0.001$). There was no other significant difference between other conditions.

Question 5 (Presence): We noticed a significant difference between conditions: $F(7, 161) = 4.5, p < 0.001, \eta_p^2 = 0.16$. Condition NONE was significantly worse than ALL ($p = 0.003$) and MW+FV ($p < 0.05$).

Question 6 (Helpfulness): Similar to Question 5, we found a significant difference between conditions: $F(7, 161) = 2.7, p = 0.01, \eta_p^2 = 0.11$; and condition NONE was significantly worse than ALL ($p = 0.02$) and MW+FV ($p = 0.04$).

Question 7 (Helpfulness): We noticed that the data did not meet the assumption of sphericity ($p < 0.01$). Accordingly, we applied Greenhouse-Geisser adjustment: $F(4.42, 101.65) = 17.33, p < 0.001, \eta_p^2 = 0.43$. Condition NONE was rated significantly worse than all other conditions at $p < 0.001$ values. Condition ALL was rated highest among all conditions and it was significantly better than NONE and MW ($p = 0.008$). Similar to ALL, FS+FV was significantly better than MW ($p = 0.02$) and NONE. Condition MW was significantly worse than ALL, FS+FV, MW+FS ($p = 0.009$), and MW+FV ($p = 0.01$).

Question 8 (Dizziness): We did not find any significant differences between the conditions in terms of ratings.

By applying Analysis II, we found both significant main effects of three independent variables, and significant interactions between them (Table 6). In

terms of the main effects, all of the three independent variables led to significant preference in ratings on most questions. We also found that FV had the most impact on the effect.

Table 6: The results of Analysis II on the subjective measures (Experiment 1)

Subjective Measures	Main Effects			Interactions			
	MW	FV	FS	MW×FV	MW×FS	FV×FS	MW×FV×FS
Q1 Movement	F = 10.0** Yes > No						
Q2 Walking	F = 8.8** Yes > No	F = 54.7*** Yes > No	F = 22.6*** Yes > No			F = 13.8**	
Q3 Realism	F = 11.6** Yes > No	F = 21.9*** Yes > No	F = 15.3** Yes > No		F = 5.5*	F = 5.2*	
Q4 Presence1	F = 6.9* Yes > No	F = 45.8*** Yes > No					
Q5 Presence2	F = 13.9** Yes > No	F = 8.3** Yes > No	F = 4.8* Yes > No				
Q6 Help			F = 7.0* Yes > No				
Q7 Help	F = 7.1* Yes > No	F = 27.8*** Yes > No	F = 22.0*** Yes > No				
Q8 Dizziness		F = 4.6* Yes < No					

* P < 0.05
 **P < 0.01
 ***p < 0.001
 df = 1/23

Besides main effects, three significant interactions were noticed. Two of them are from Q2 Realism. They are MW×FS and FV×FS. All of the interactions showed that the effects of FV or MW became less noticeable in the presence of FS (Figure 22).

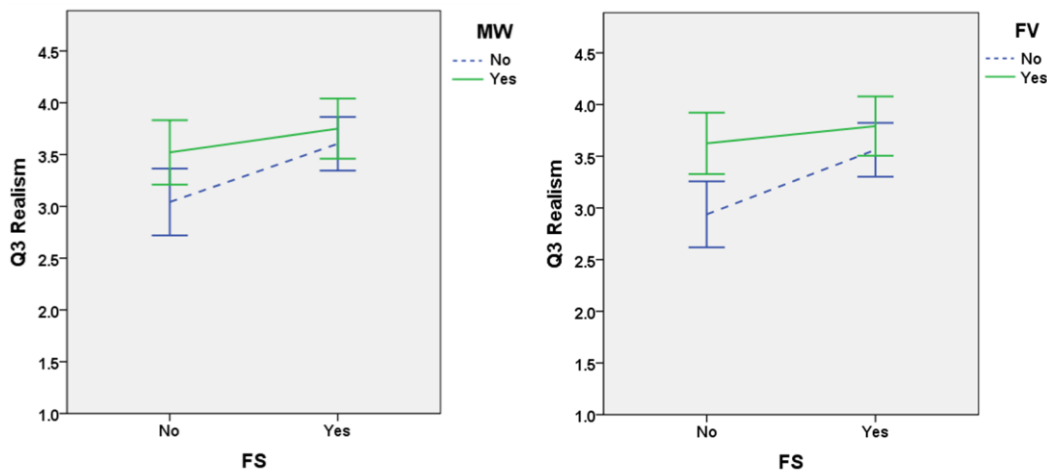

Figure 22: Interactions of MW×FS and FV×FS in Q3 Realism (Analysis II)

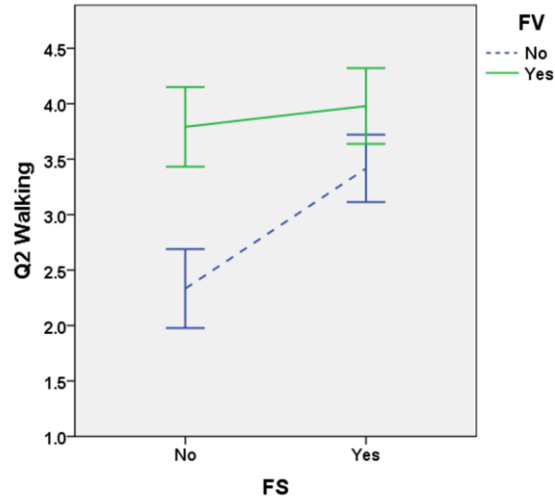

Figure 23: Interaction of FV×FS in Q2 Walking (Analysis II)

4.2.7 Discussion

In this section, we first discuss the effect of tactile cues individually, then discuss their effects and interactions in combination.

Previous studies focused more on examining the subjective effect of movement wind in vehicle simulations [10, 39]. Our results showed that the effect can be further applied to walking simulations, where it not only enhances presence and movement sensation, but can also play a positive role in improving walking sensation. However, it did not show any noticeable aid to maintaining spatial orientation.

From our study, the positive effects of footstep vibration on walking sensation were shown for immersive VEs. They were also strongly preferred in terms of overall presence. Furthermore, we found that people’s spatial orientation can be better maintained with the support of footstep vibrations; they helped reduce the absolute distance error in the triangle completion task. There are two main reasons that may cause the effect. One is about the strategy that the participants may have applied in the task. Half of the 24 participants mentioned that they tried to count footsteps to measure how far they went when they experienced conditions with FV or FS, but FS did not show a significant main effect on performance. The other reason could be that FV contributed more to the

self-motion perception, which might help in maintaining spatial orientation during travel in VEs [31].

From the results on individual contributions of the tactile cues, our first hypothesis on task performance (H1.1) was partially supported, and our second hypothesis on user experience (H1.2) was fully supported.

By observing the effects and interactions in combination, we showed strong support for the common intuition mentioned in previous work, that in multi-sensory systems, adding more cues tends to get more preference [3, 31]. This is based on the finding from Analysis I that participants did not like the NONE condition and overwhelmingly preferred the ALL condition, and the ratings generally increased with the number of cues. However, despite the “more cues equals greater preference” rule, we found interactions between multi-sensory cues. All three interactions found in Analysis II showed that the existence of one cue could make the effect of another cue unnoticeable. This kind of interaction was mostly found between FV and FS, but not between FV and MW. One possible and intuitive reason could be that the more closely the two cues are related or matched, the more likely they might mask each other. Another finding is that the two tactile cues had different levels of impact. We found that FV was stronger, both subjectively and objectively, while MW was a relatively weak cue for influencing positive performance or experience. This finding motivated us to further investigate wind feedback as an informational cue in a follow-up experiment.

4.3 Follow-up Experiment

In Experiment 1, 10 of the 24 participants mentioned during the post-experiment feedback that they would have preferred to have directional wind (wind blowing from a fixed direction) in addition to movement wind. They predicted that directional wind would help them spatially orient themselves in the VE, like a visual landmark in the real world. Consequently, we conducted a follow-up

experiment to investigate whether or not adding directional wind would affect user performance and experience.

4.3.1 Experimental Design

All trials in the experiment included visuals, ambient audio feedback, Footstep Vibration (FV), and Footstep Sound (FS). There were four combinations of the two independent variables, with/without Movement Wind (MW) and with/without Directional Wind (DW). Each participant was exposed to all four conditions (Table 7). Four triangle layouts were used, as shown in Figure 24. With each condition, the participant went through all the layouts. Thus, every participant experienced $4 \times 4 = 16$ triangle-completion trials. Overall, we collected $16 \times 16 = 256$ data points.

Table 7: Experimental Conditions.

		DW	
		Yes	No
MW	Yes	ALL	MW
	No	DW	NONE

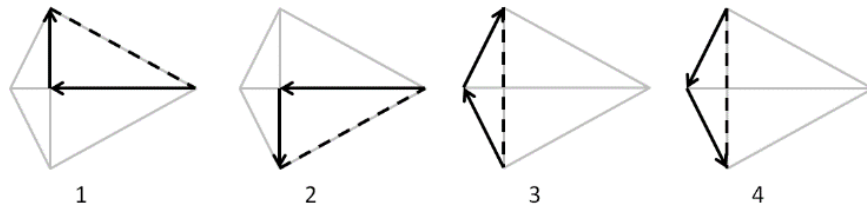

Figure 24: Triangle Path Layouts.

4.3.2 Participants

A total of 16 participants (9 male) took part in the experiment. Their ages ranged from 19 to 34 years ($M = 25$, $SD = 4.25$). The participants for Experiment 2 were all different from Experiment 1, but with similar demographics. The score of the pre-test was within the range from -1 to 48 ($M = 18.5$, $SD = 12.64$).

4.3.3 Results

Below we present the results of the second study. Similar to the first study, we used repeated measure ANOVAs with condition as an independent variable of

four levels (Analysis I) and 2x2 factorial repeated measures ANOVA with two independent variables DW and MW (Analysis II) to analyze the data.

4.3.3.1 Objective Data

In Analysis I, we did not find any significant differences between conditions on any of the objective dependent variables. Similarly for Analysis II, we did not find significant main effects or interactions. Contrary to our expectations based on participant feedback in the main experiment, Directional Wind (DW) did not further improve performance based on FV and FS.

The correlation between performance and GZ-test score was analyzed. Among all the objective measures, we found that the total time taken for the trials and GZ-test score were strongly positively correlated, $r(16) = 0.525, p = 0.037$. Specially, we found that the time taken for the third (returning) side of the triangle (Side 3) and GZ-test score were strongly positively correlated, $r(16) = 0.629, p = 0.009$. We also found that the Estimated Distance and GZ-test score were moderately positively correlated, $r(16) = 0.54, p = 0.31$. No significant correlation was found between GZ-test score and other objective measures.

4.3.3.2 Subjective Data

In Analysis I, we found significant difference in Q7 Helpfulness, $F(3, 45) = 12.1, p < 0.001, \eta_p^2 = 0.45$ (Figure 25). In the Tukey's HSD post-hoc test, we found NONE was significantly worse than all the other conditions, $p < 0.05$. We also found DW was significantly better than MW, $p < 0.05$.

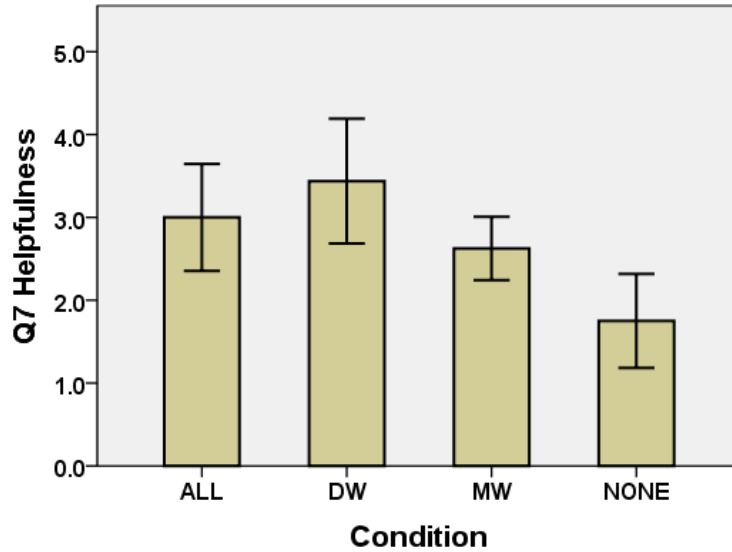

Figure 25: Homogeneous means of conditions on Q7 Helpfulness

In the results of Analysis II (Table 8), we found there was no main effect on Movement, Realism and Presence. In the questions of Helpfulness (Q6 and Q7), we found significant main effect of DW on Q7. Surprisingly, we noticed a significant negative main effect of MW on Q6. Two significant cross-over interactions were found in Q4 Presence and Q7 Helpfulness (Figure 26).

Table 8: The results of Analysis II on the subjective measures (Experiment 2)

Subjective Measures	Main Effects		Interaction
	DW	MW	DW×MW
Q1 Movement			
Q3 Realism			
Q4 Presence1			F = 5.3*
Q5 Presence2			
Q6 Help		F = 8.0*, Yes < No	
Q7 Help	F = 23.8***, Yes > No		F = 11.7**
Q8 Dizziness			

* P < 0.05
 **P < 0.01
 ***p < 0.001
 df = 1/23

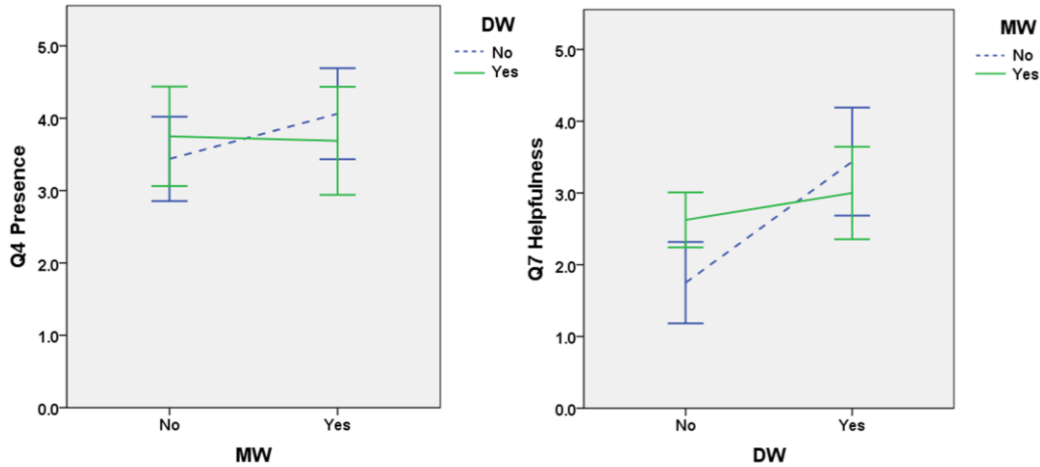

Figure 26: Interactions of DW×MW in Q4 Presence and Q7 Helpfulness

4.3.4 Discussion

We had expected that people would use DW as a virtual compass to help performance, so that the absolute angular error could be reduced, while from the results of the objective measures we found that the addition of DW did not further improve user performance in the existence of FV and FS. Hence, our first hypothesis (H2.1) was not supported. The objective results were contrary to the participants' strong expectation on the helpfulness, which was shown in Q7. Our second hypothesis (H2.2) was partially supported. In addition, seven out of 16 participants mentioned that they used DW as a compass to help recognize orientation. One explanation for the contradiction between people's expectations and real performance could be that people overestimated their skills at making use of wind direction. Another possible reason could be a system limitation, i.e., the orientations of head tracker and the chair were not separated, which might prohibit people from looking around while moving in a certain direction. This might have influenced their natural behavior while performing the task. A third possible explanation is sensory overload. In this experiment, all conditions had FV and FS, and DW barely showed positive influence on either performance or experience. It could be that other visual, audio, and/or floor vibration cues were stronger than the sensation of wind. Having multiple cues at the same time might have also caused a sensory overload, which means more sensory input was provided to the participant at a given time than they could process [20]. A sensory

overload can result in confusion and cognitive strain. While there are individual differences in how people overcome sensory overload, generally, the human brain is trained to ignore certain sensory inputs based on the given situation [22].

Another support for the explanation of sensory overload from our experiment was that, we found a negative impact of MW on user experience, based on one main effect (Q6) and two crossover interactions. This was not found in Experiment 1, where all the significant effects were positive. It indicates that the addition of another cue (DW in our case) could even reduce the preference of an existing cue from the same sensory channel.

5 Conclusion

In this thesis, a framework is presented for defining how multi-sensory cues can be systematically discussed, combined, and evaluated in the context of immersive VR. After identifying a region of this space to explore, we then set about creating a method for effectively controlling the delivery of wind to an immersed user, focusing on reducing the latency inherent in such systems. In addition, we created a raised floor with vibration feedback to simulate footstep vibrations for non-walking locomotion. Finally, we recreated a ChairIO [1] approach to non-fatiguing locomotion. This allowed us to combine off-the-shelf visual and audio support with our experimental systems for secondary cue delivery and locomotion.

We then used this system to run two user studies to investigate the effect of tactile cues (FS, FV, MW, and DW) on spatial orientation performance and user experience, in order to measure the contribution of tactile cues (FV, MW and DW) individually and in combination. Combining the results from both experiments, we found that, the simulated tactile cues based on real world situations have positive effects during non-fatiguing walking in VEs, even in the presence of known support like wide FoV, and vestibular, visual, and auditory cues. Generally, adding more cues leads to stronger preference. However, this is not always true. First, we saw a stronger effect of floor vibration on both performance and experience than of wind, and thus one might mask another. Second, closely related cues (FV and FS, MW, and DW) tend to interact with each other.

Future researchers and developers should consider introducing these cues into their systems. We particularly suggest including footstep vibration into the non-fatiguing walking experience, and adding more cues based on the goals of the system, taking possible interactions into account. Although wind feedback was not found to be very helpful in our experiments, we intend to investigate more about this cue in other task scenarios, and to increase the intensity of the wind

feedback. We believe our results will help future research in this direction and eventually improve the overall quality of multi-sensory immersive VR systems.

This was our initial exploration of multi-sensory cues using our VR system with walking simulation. We chose a small fraction of a much larger design space to investigate as shown in Table 1. We will explore other cues in future studies, in order to solve different problems. We intend to improve the quality of the visual feedback to make it more realistic and to add cues such as head bobbing into the experience, which we believe will make it more realistic and may improve the user experience. We would also like to test our system with other tasks (e.g., games) that make use of these multi-sensory cues in a more direct way to see what differences this makes in the usefulness of these cues.

References

- [1] Beckhaus, S., Blom, K. J., & Haringer, M. (2007). ChairIO--the chair-based Interface. *Concepts and Technologies for Pervasive Games: A Reader for Pervasive Gaming Research, 1*, 231–264.
- [2] Bowman, D. A., Davis, E. T., Hodges, L. F., & Badre, A. N. (1999). Maintaining Spatial Orientation during Travel in an Immersive Virtual Environment. *Presence: Teleoperators and Virtual Environments*, 8(6), 618–631.
- [3] Bowman, D. A., Kruijff, E., LaViola, J. J., Jr, & Poupyrev, I. (2004). *3D user interfaces: theory and practice*. Addison-Wesley.
- [4] Buttkicker LFE URL: <http://www.thebuttkicker.com/lfe> (Last accessed: September 16th, 2015)
- [5] Campos, J. L., & Bühlhoff, H. H. (2012). Multimodal Integration during Self-Motion in Virtual Reality. In M. M. Murray & M. T. Wallace (Eds.), *The Neural Bases of Multisensory Processes*. Boca Raton (FL): CRC Press.
- [6] Cardin, S., Thalmann, D., & Vexo, F. (2007). Head mounted wind. In *proceeding of the 20th annual conference on Computer Animation and Social Agents (CASA2007)* (pp. 101–108).
- [7] Chance, S. S., Gaunet, F., Beall, A. C., & Loomis, J. M. (1998). Locomotion Mode Affects the Updating of Objects Encountered During Travel: The Contribution of Vestibular and Proprioceptive Inputs to Path Integration. *Presence: Teleoperators and Virtual Environments*, 7(2), 168–178.
- [8] De Barros, P. G., & Lindeman, R. W. (2014). Multi-sensory urban search-and-rescue robotics: improving the operator's omni-directional perception. *Frontiers in Robotics and AI*, 1, 14.

- [9] Debarba, H. G., Grandi, J. G., Oliveski, A., Domingues, D., Maciel, A., & Nedel, L. P. (n.d.). (2009). WindWalker: UsingWind as an Orientation Tool in Virtual Environments. *Symposium on Virtual and Augmented Reality* (pp.133-140).
- [10] Deligiannidis, L., & Jacob, R. J. K. (2006). The VR Scooter: Wind and Tactile Feedback Improve User Performance. In *Proceedings of the IEEE Symposium on 3D User Interfaces, 2006* (pp. 143–150).
- [11] Feng, M., Lindeman, R. W., Abdel-Moati, H., & Lindeman, J. C. (2015). Haptic ChairIO: A system to study the effect of wind and floor vibration feedback on spatial orientation in VEs. In *3D User Interfaces (3DUI), 2015 IEEE Symposium on* (pp. 149–150).
- [12] Heilig, M. L. (1962). Sensorama simulator, US Patent No. 3050870. August.
- [13] Hollerbach JM (2002) Locomotion interfaces. In: *Stanney KM (ed) Handbook of virtual environments*. Lawrence Erlbaum, New York, pp 239–254
- [14] Hülsmann, F., Mattar, N., Fröhlich, J., & Wachsmuth, I. (2013). Wind and warmth in virtual reality-Requirements and chances. In *Proceedings of the Workshop Virtuelle & Erweiterte Realität 2013* (pp. 133-144).
- [15] Klatzky, R. L., Loomis, J. M., Beall, A. C., Chance, S. S., & Golledge, R. G. (1998). Spatial Updating of Self-Position and Orientation During Real, Imagined, and Virtual Locomotion. *Psychological Science*, 9(4), 293–298.
- [16] Kojima, Y., Hashimoto, Y., & Kajimoto, H. (2009). A Novel Wearable Device to Present Localized Sensation of Wind. In *Proceedings of the International Conference on Advances in Computer Entertainment Technology* (pp. 61–65). New York, NY, USA: ACM.
- [17] Kulkarni, S. D., Minor, M. A., Deaver, M. W., Pardyjak, E. R., & Hollerbach, J. M. (2012). Design, Sensing, and Control of a Scaled Wind

Tunnel for Atmospheric Display. *Mechatronics, IEEE/ASME Transactions on*, 17(4), 635–645.

- [18] Kyritsis, M., & Gulliver, S. R. (n.d.). Gilford Zimmerman orientation survey: A validation. In *2009 7th International Conference on Information, Communications and Signal Processing (ICICS)* (pp. 1–4). IEEE.
- [19] Lecuyer, A., Burkhardt, J.-M., Henaff, J.-M., & Donikian, S. (2006). Camera Motions Improve the Sensation of Walking in Virtual Environments. In *Virtual Reality Conference, 2006* (pp. 11–18).
- [20] Lipowski, Z. J. (1975). Sensory and information inputs overload: behavioral effects. *Comprehensive Psychiatry*, 16(3), 199–221.
- [21] Loomis, J. M., Klatzky, R. L., Golledge, R. G., & Philbeck, J. W. (1999). Human navigation by path integration. *Wayfinding Behavior: Cognitive Mapping and Other Spatial Processes*, 125–151.
- [22] Malhotra, N. K. (1984). Information and sensory overload. *Psychology and Marketing*, 1(3-4), 9–21.
- [23] Mohler, Betty J., Sarah H. Creem-Regehr, and William B. Thompson. "The influence of feedback on egocentric distance judgments in real and virtual environments." *Proceedings of the 3rd symposium on Applied perception in graphics and visualization*. ACM, 2006.
- [24] Moon, T., & Kim, G. J. (2004). Design and Evaluation of a Wind Display for Virtual Reality. In *Proceedings of the ACM Symposium on Virtual Reality Software and Technology* (pp. 122–128). New York, NY, USA: ACM.
- [25] Nordahl, R. (2005). Self-induced footsteps sounds in virtual reality: Latency, recognition, quality and presence. In *The 8th Annual International Workshop on Presence, PRESENCE 2005* (pp. 353–355).
- [26] Papetti, S., & Fontana, F. (2012). Effects of audio-tactile floor augmentation on perception and action during walking: Preliminary results.

In *Proc. of the 9th Sound and Music Computing Conf.*,(Copenhagen, Denmark) (pp. 17–22).

- [27] Péruch, P., May, M., & Wartenberg, F. (1997). Homing in virtual environments: effects of field of view and path layout. *Perception*, 26(3), 301–311.
- [28] Popescu, G. V., Burdea, G. C., & Trefftz, H. (2002). Multimodal interaction modeling. *Handbook of Virtual Environments: Design, Implementation, and Applications*, 435–454.
- [29] Presson CC, Montello DR (1994) Updating after rotational and translational body movements: coordinate structure of perspective space. *Perception* 23(12):1447–1455
- [30] Riecke, B. E., & Wiener, J. M. (2007). Can People Not Tell Left from Right in VR? Point-to-origin Studies Revealed Qualitative Errors in Visual Path Integration. In *Virtual Reality Conference, 2007. VR '07. IEEE* (pp. 3–10).
- [31] Riecke, Bernhard E., and Jörg Schulte-Pelkum. (2013) "Perceptual and cognitive factors for self-motion simulation in virtual environments: how can self-motion illusions (“vection”) be utilized?." *Human Walking in Virtual Environments*. Springer New York, 2013. 27-54.
- [32] Sawada, E., Ida, S., Awaji, T., Morishita, K., Aruga, T., Takeichi, R., Fujii, T., Kimura, H., Nakamura, T., Furukawa, M., Shimizu, N., Tokiwa, T., Nii, H., Sugimoto, M., Inami, M.. (2007). BYU-BYU-View: A Wind Communication Interface. In *ACM SIGGRAPH 2007 Emerging Technologies*. New York, NY, USA: ACM.
- [33] Swooper – Air URL: <http://www.swopper.com/swopper-air-5/> (Last accessed: September 16th, 2015)
- [34] Tan, D. S., Gergle, D., Scupelli, P. G., & Pausch, R. (2004). Physically Large Displays Improve Path Integration in 3D Virtual Navigation Tasks.

In *Proceedings of the SIGCHI Conference on Human Factors in Computing Systems* (pp. 439–446). New York, NY, USA: ACM.

- [35] Tan, H. Z., Gray, R., Young, J. J., & Traylor, R. (2003). A haptic back display for attentional and directional cueing. *Haptics-E*, 3(1), 1–20.
- [36] Terziman, L., Marchal, M., Multon, F., Arnaldi, B., & Lecuyer, A. (2012). The King-Kong Effects: Improving sensation of walking in VR with visual and tactile vibrations at each step. In *3D User Interfaces (3DUI), 2012 IEEE Symposium on* (pp. 19–26).
- [37] Turchet, L., Burelli, P., & Serafin, S. (2013). Haptic feedback for enhancing realism of walking simulations. *IEEE Transactions on Haptics*, 6(1), 35–45.
- [38] Våljamäe, A., Larsson, P., Västfjäll, D., & Kleiner, M. (2006). Vibrotactile enhancement of auditory-induced self-motion and spatial presence. *Journal of the Audio Engineering Society. Audio Engineering Society*, 54(10), 954–963.
- [39] Verlinden, J. C., Mulder, F. A., Vergeest, J. S., de Jonge, A., Krutiy, D., Nagy, Z., Logeman, B. J., Schouten, P. (2013). Enhancement of Presence in a Virtual Sailing Environment through Localized Wind Simulation. *Procedia Engineering*, 60, 435–441.
- [40] Wan, X., Wang, R. F., & Crowell, J. A. (2013). Effects of Basic Path Properties on Human Path Integration. *Spatial Cognition and Computation*, 13(1), 79–101.

Appendix A Communication Protocol

Category	Description	Data from VR Simulation		Acknowledge
		String Format	Example	
Overall	Set the dimension of the CAVE.	SetCave @Size=width#height	SetCave @Size=3.040#2.286	SetCaveDone
Overall	Terminate the hardware and remove all the software data.	Reset		
Overall	Add a user. (Id should always be 0.)	AddUser @Id=ID @Position=x#y#z @OffsetInCave=x#y#z	AddUser @Id=0 @Position=1.2#2.2#3.2 @OffsetInCave=1#1#1	AddUserDone
Overall	Update the user data.	UpdateUser @Id=0 @Position=x#y#z @OffsetInCave=x#y#z	UpdateUser @Id=0 @Position=1.2#2.2#3.2 @OffsetInCave=1#1#1	
Wind	Set the properties of the fans. (This is for control override of certain fans.)	SetFan @Id=[0-8]/All @SpeedValue=[0-255] @PanValue=[0-180] @TiltValue=[0-90]	SetFan @Id=All @SpeedValue=255 @PanValue=100 @TiltValue=90	
Wind	Resume regular mode after control override.	Resume		
Wind	Update Global Wind.	SetGlobalWind @SpeedValue=[0-255] @Direction=x#y#z	SetGlobalWind @SpeedValue=100 @Direction=1.0#1#1.0	
Wind	Add a Wind Object. Radius is the falloff.	AddWindObject @Id=ID @Position=x#y#z @Direction=x#y#z @Radius=r @SpeedValue=[0-255]	AddWindObject @Id=0 @Position=1.2#2.2#3.2 @Direction=1#2#3 @Radius=2.0 @SpeedValue=255	AddWindObject Done
Wind	Update a Wind Object.	UpdateWindObject @Id=ID @Position=x#y#z @Direction=x#y#z/All @Radius=r @SpeedValue=[0-255]	UpdateWindObject @Id=0 @Position=1.2#2.2#3.2 @Direction=1#2#3 @Radius=2.0 @SpeedValue=255	
Wind	Add a Wind Volume. (Heading is the degree of rotation. TunnelEffect is the wind speed of tunnel effect.)	AddWindVolume @Id=ID @SpeedValue=[0-255] @Dimension=length#width#height	AddWindVolume @Id=0 @SpeedValue=255 @Dimension=1#1#100 @Position=1.2#2.2#3.2	AddWindVolume Done

		@Position=x#y#z @Direction=x#y#z @Heading=h @TunnelEffect=[0-255]	@Direction=1#2#3 @Heading=30 @TunnelEffect=50	
Wind	Update a Wind Volume.	UpdateWindVolume @Id=ID @SpeedValue=[0-255] @Dimension=length#width #height @Position=x#y#z @Direction=x#y#z @Heading=h @TunnelEffect=[0-255]	UpdateWindVolume @Id=0 @SpeedValue=255 @Dimension=1#1#100 @Position= 1.2#2.2#3.2 @Direction=1#2#3 @Heading=30 @TunnelEffect=50	
Vibration	Add a Vibration Object.	AddVibrationObject @Id=ID @Position=x#y#z @Radius=r @Amplitude=[(int)0-255] @Frequency=f	AddVibrationObject @Id=0 @Position=1.2#2.2#3.2 @Radius=2.0 @Amplitude=100 @Frequency=50	AddVibration Object Done
Vibration	Update a Vibration Object.	UpdateVibrationObject @Id=ID/All @Position=x#y#z @Radius=r @Amplitude=[0-255] @Frequency=f	UpdateVibrationObject @Id=0 @Position=1.2#2.2#3.2 @Radius=2.0 @Amplitude=100 @Frequency=50	

Appendix B Grouped Path Visualizations

Main Experiment – Triangle Path 1

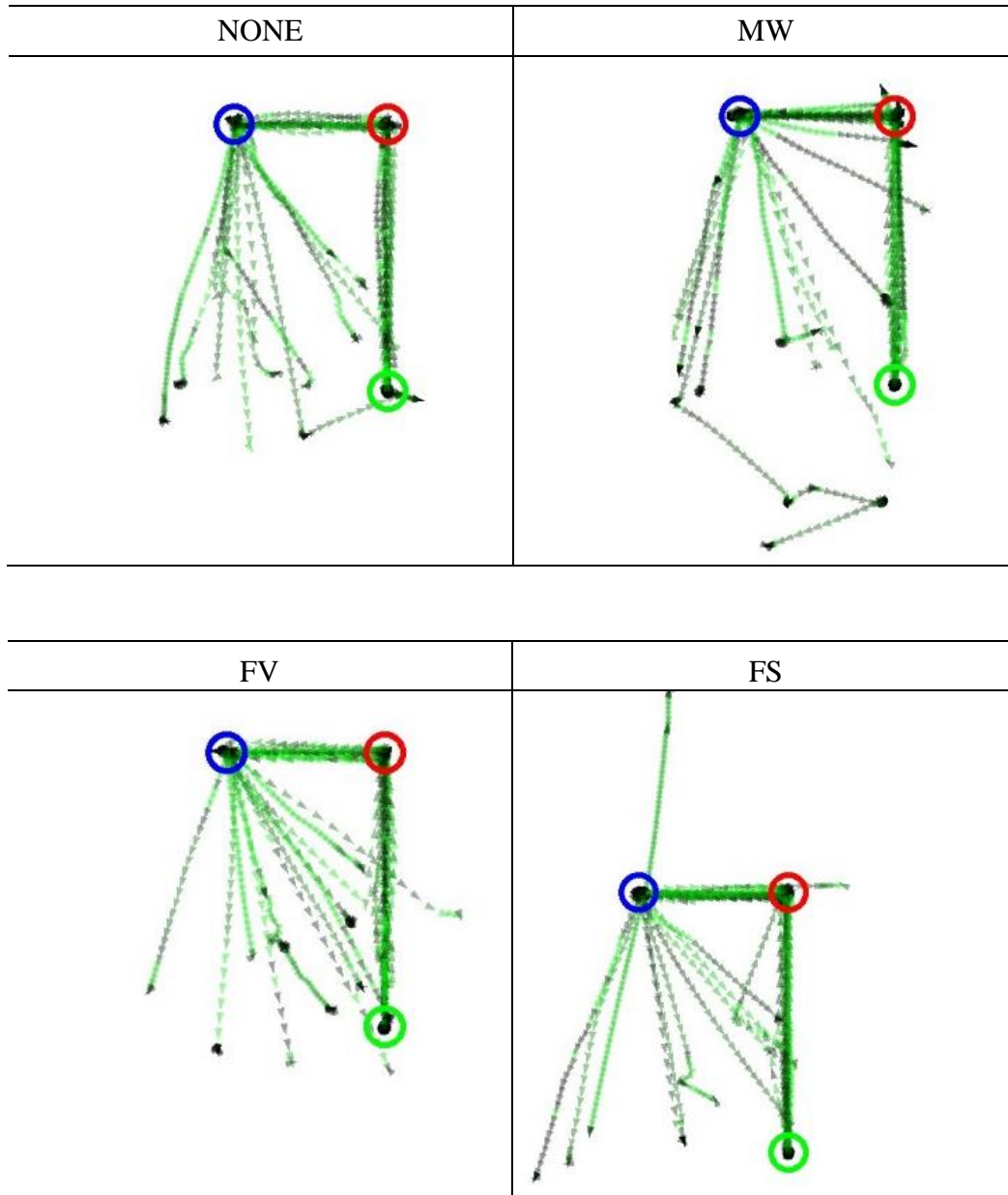

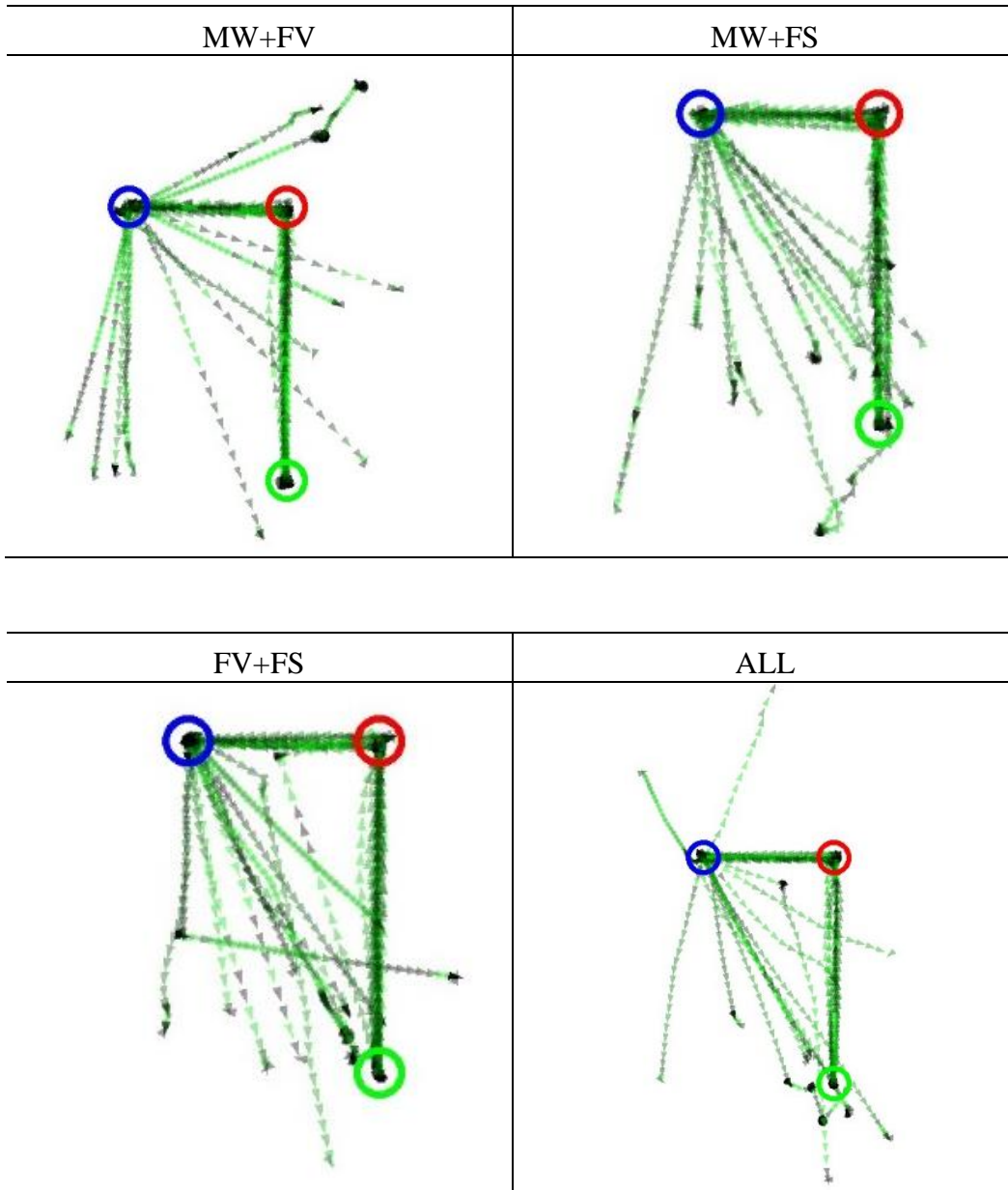

Main Experiment – Triangle Path 2

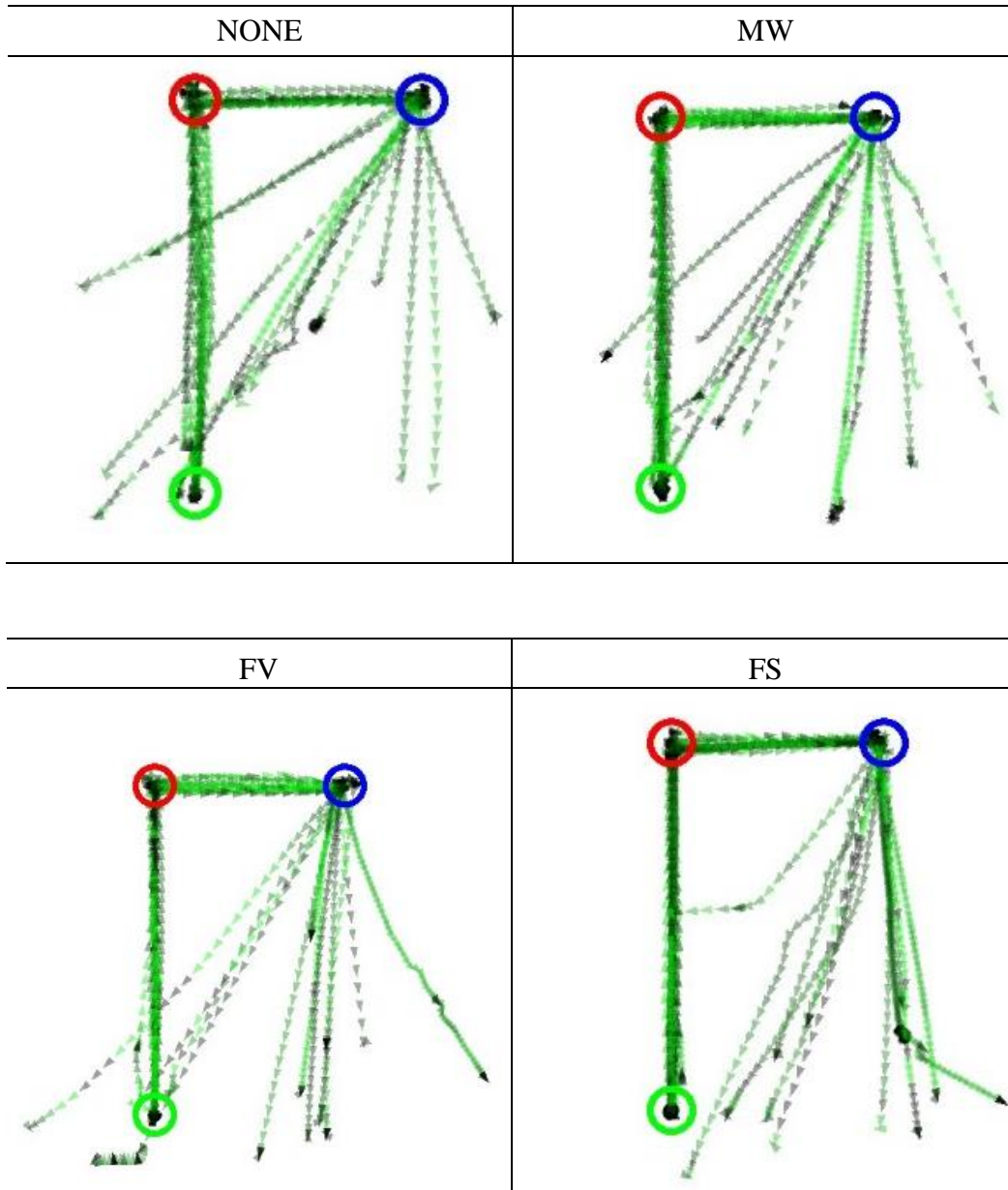

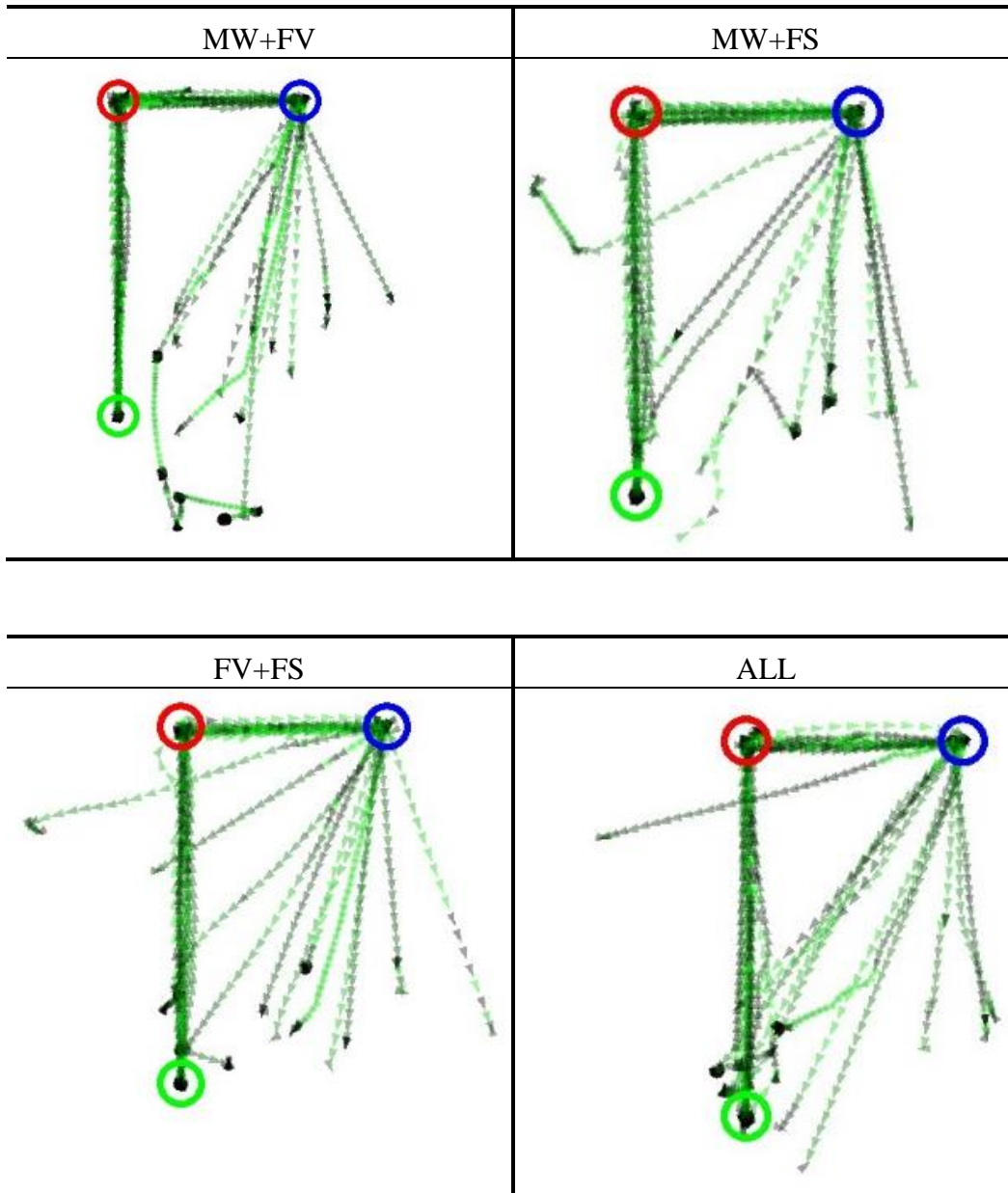

Main Experiment – Triangle Path 3

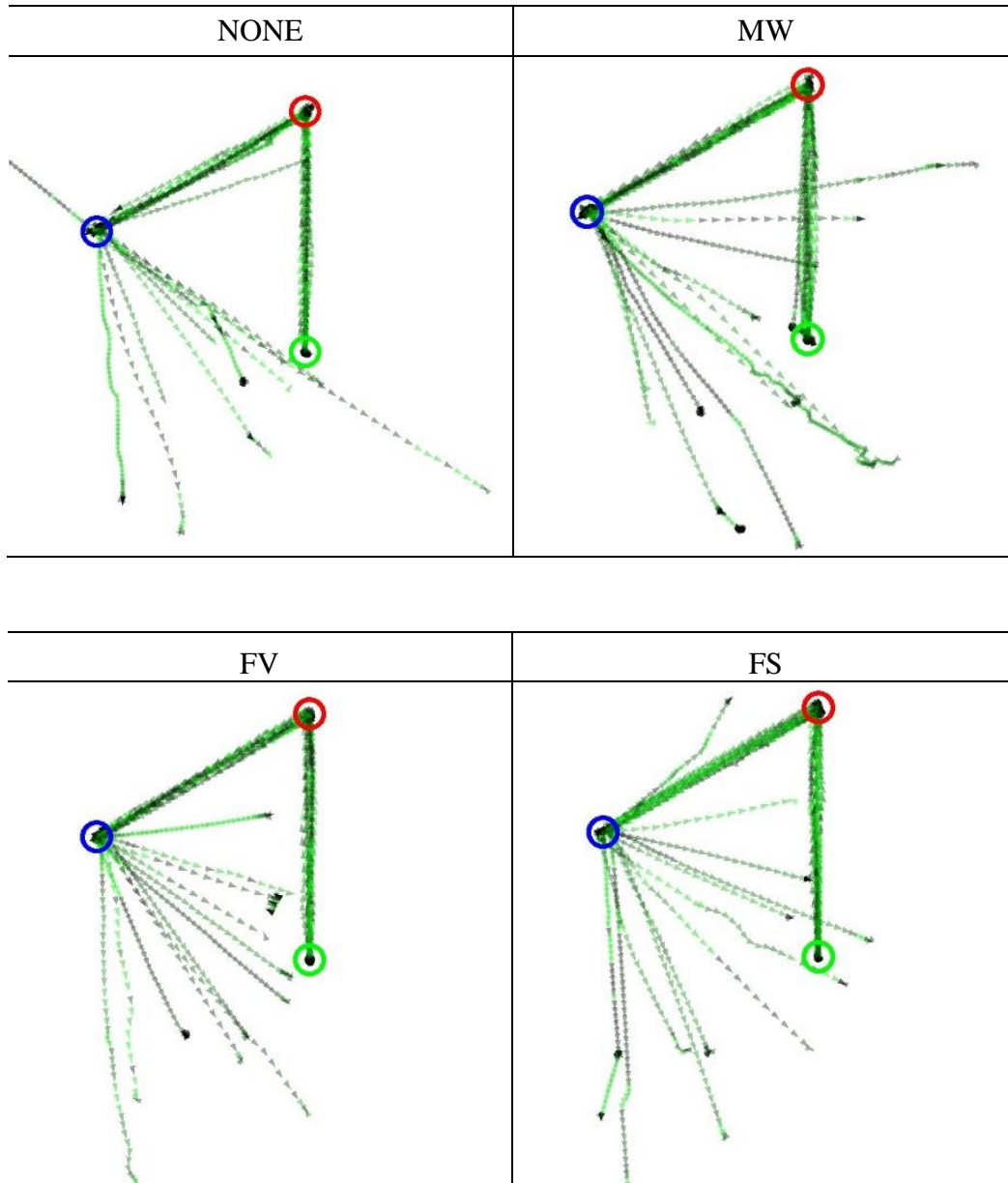

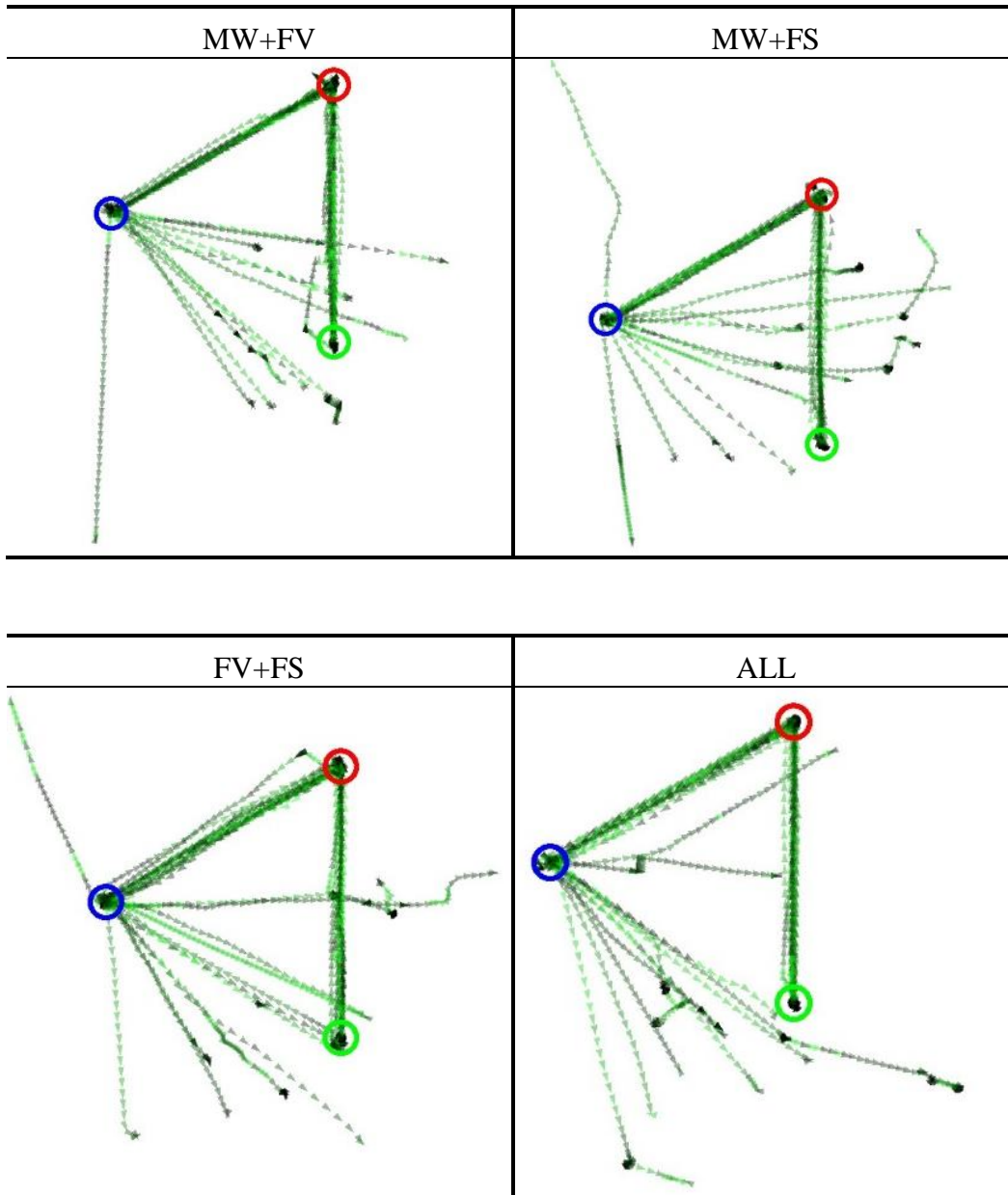

Main Experiment – Triangle Path 4

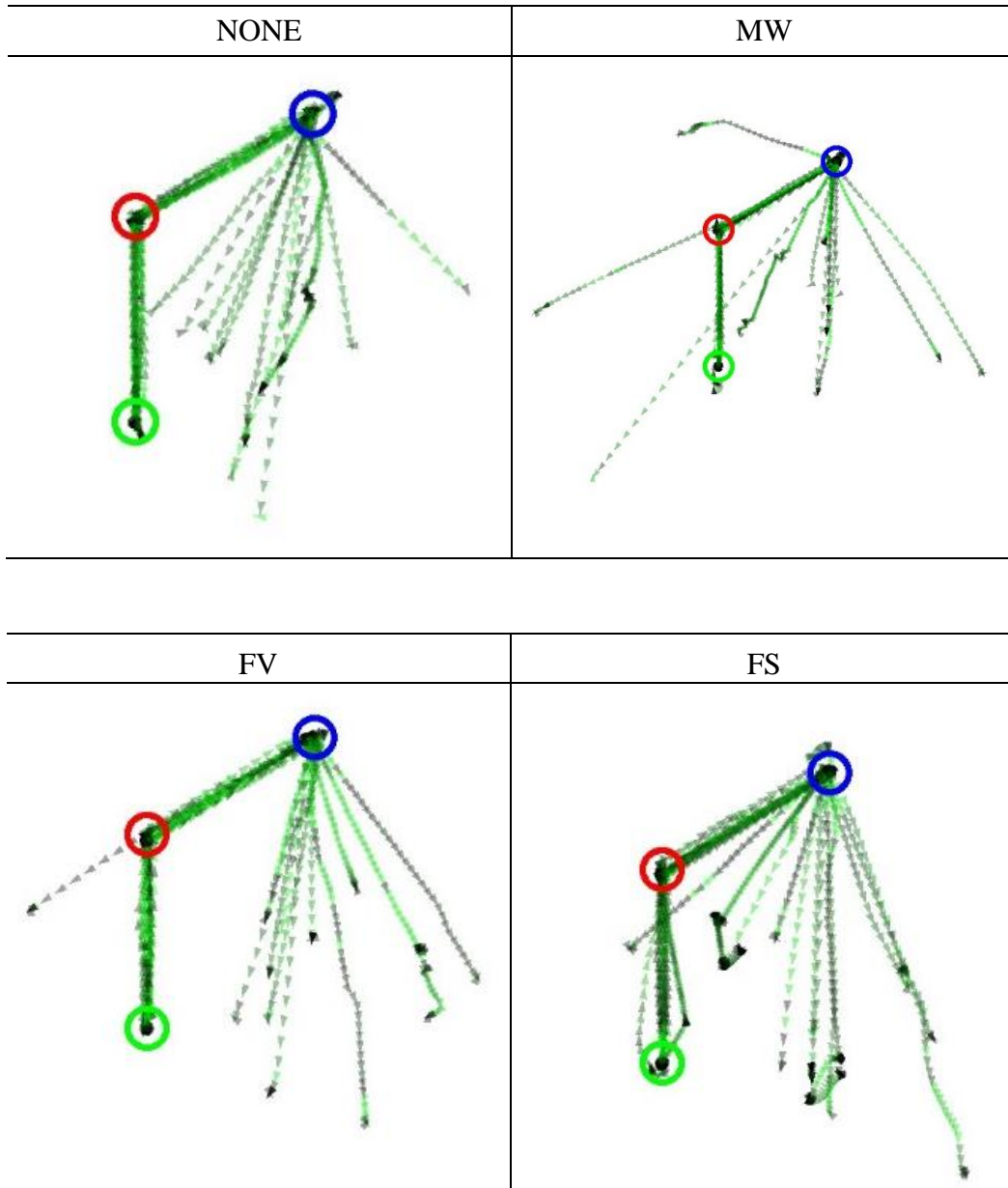

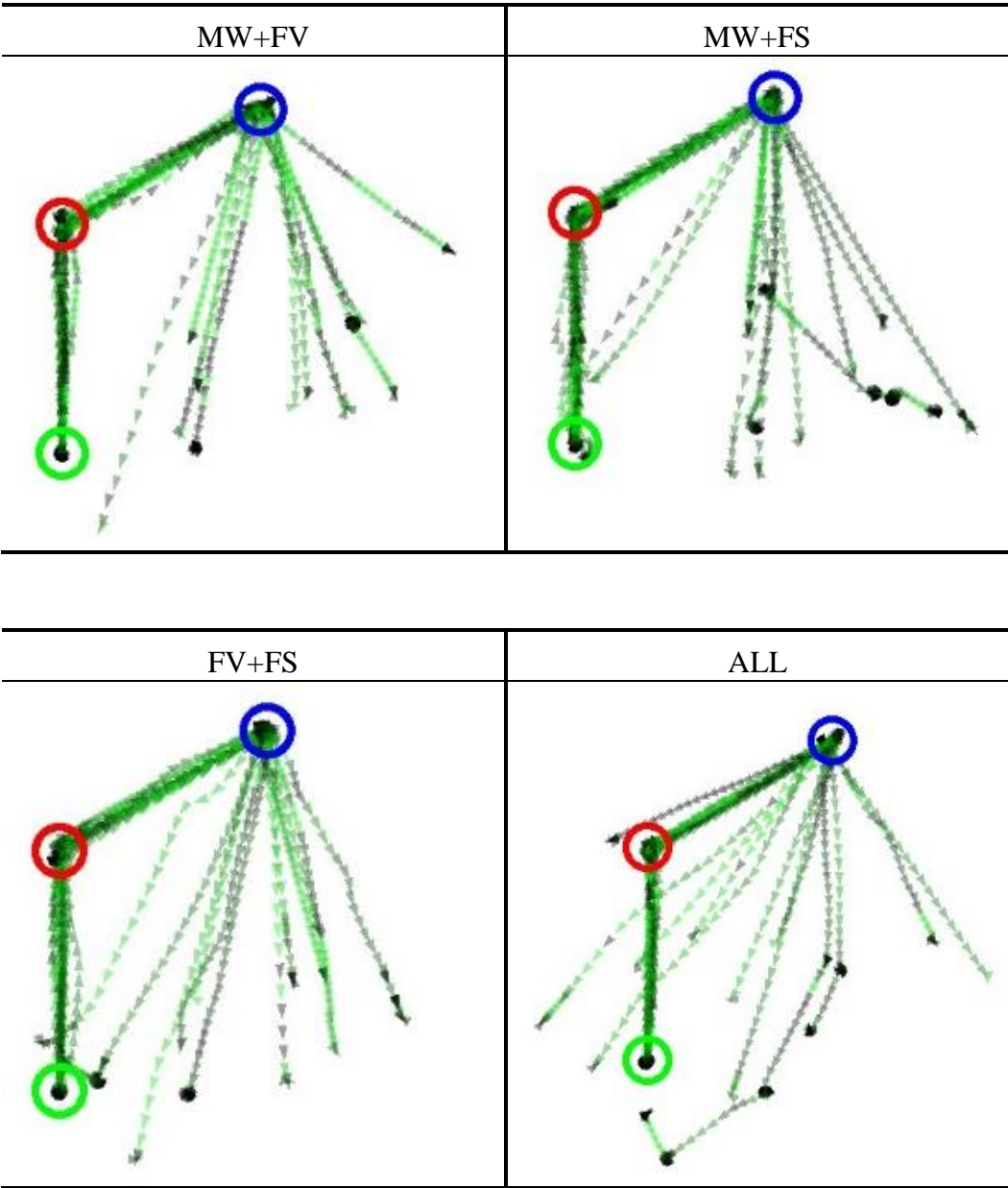

Main Experiment – Triangle Path 5

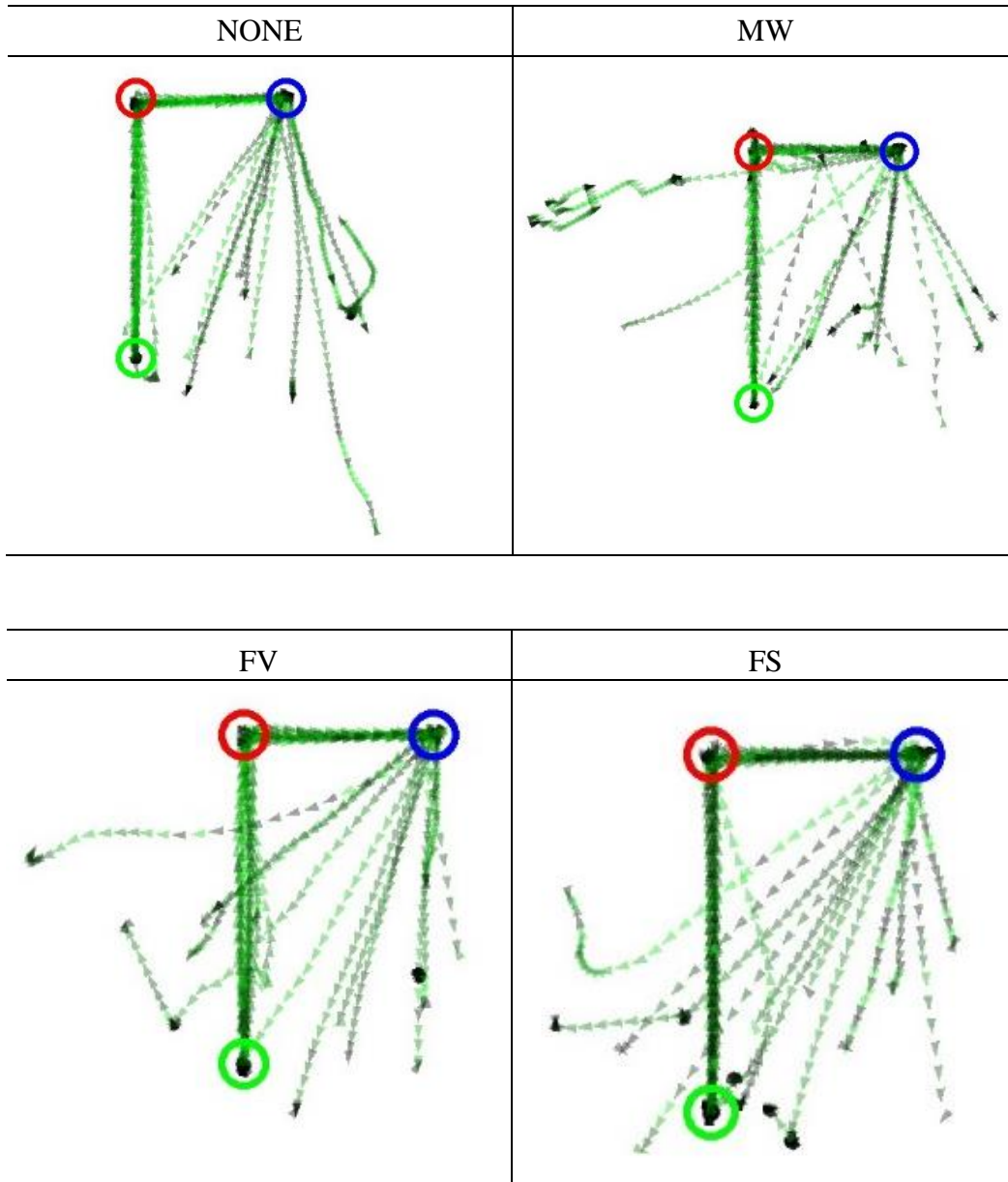

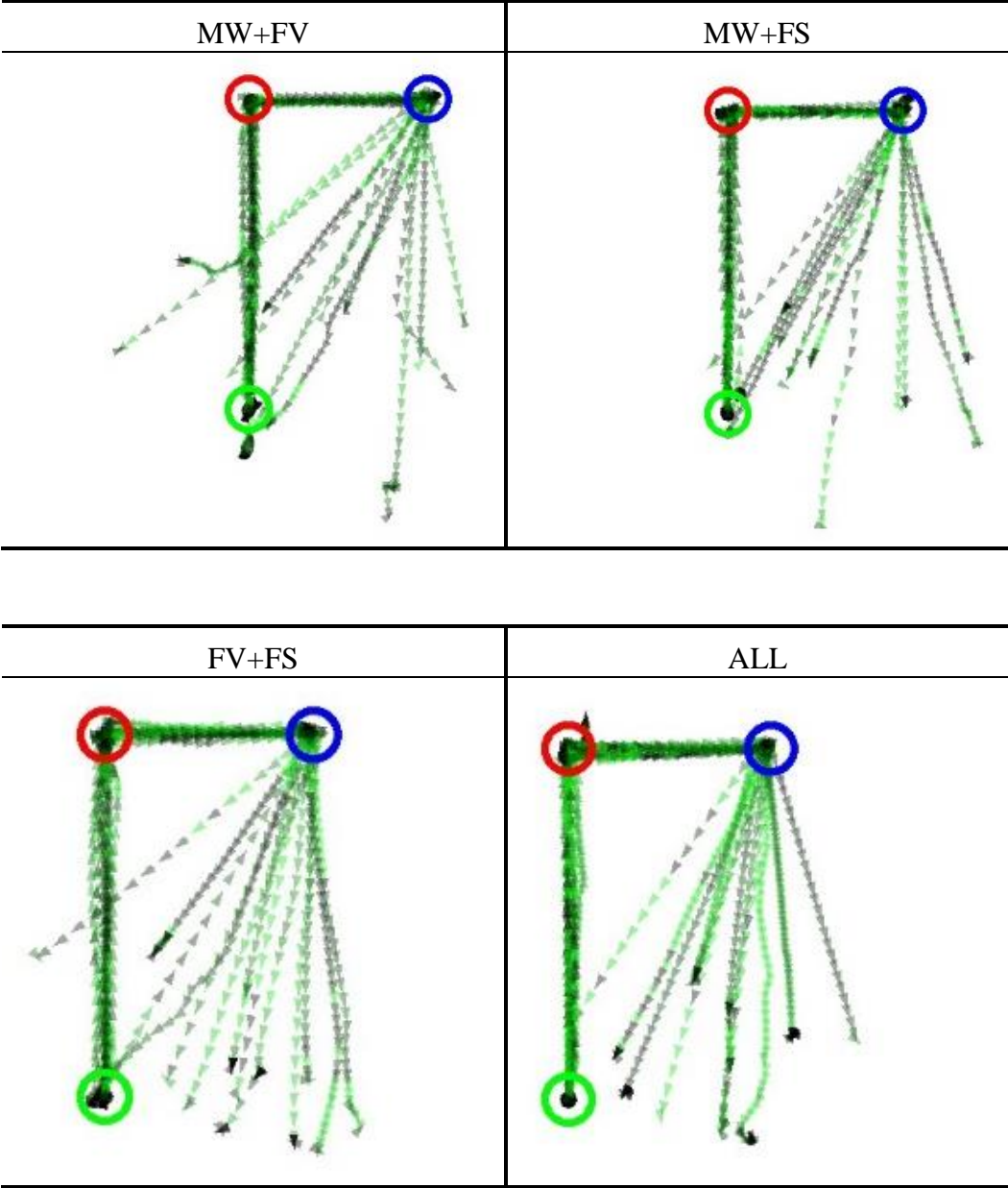

Main Experiment – Triangle Path 6

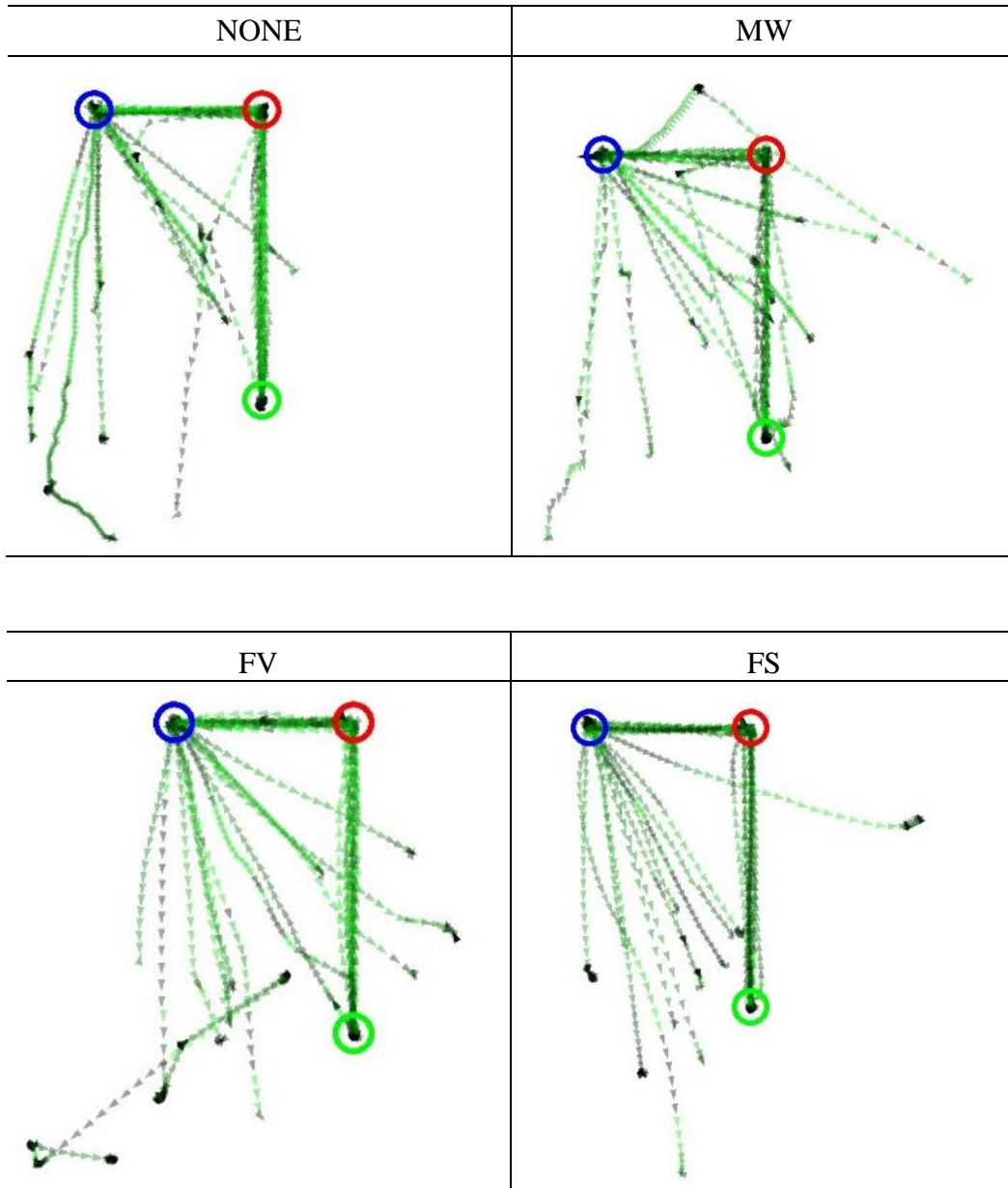

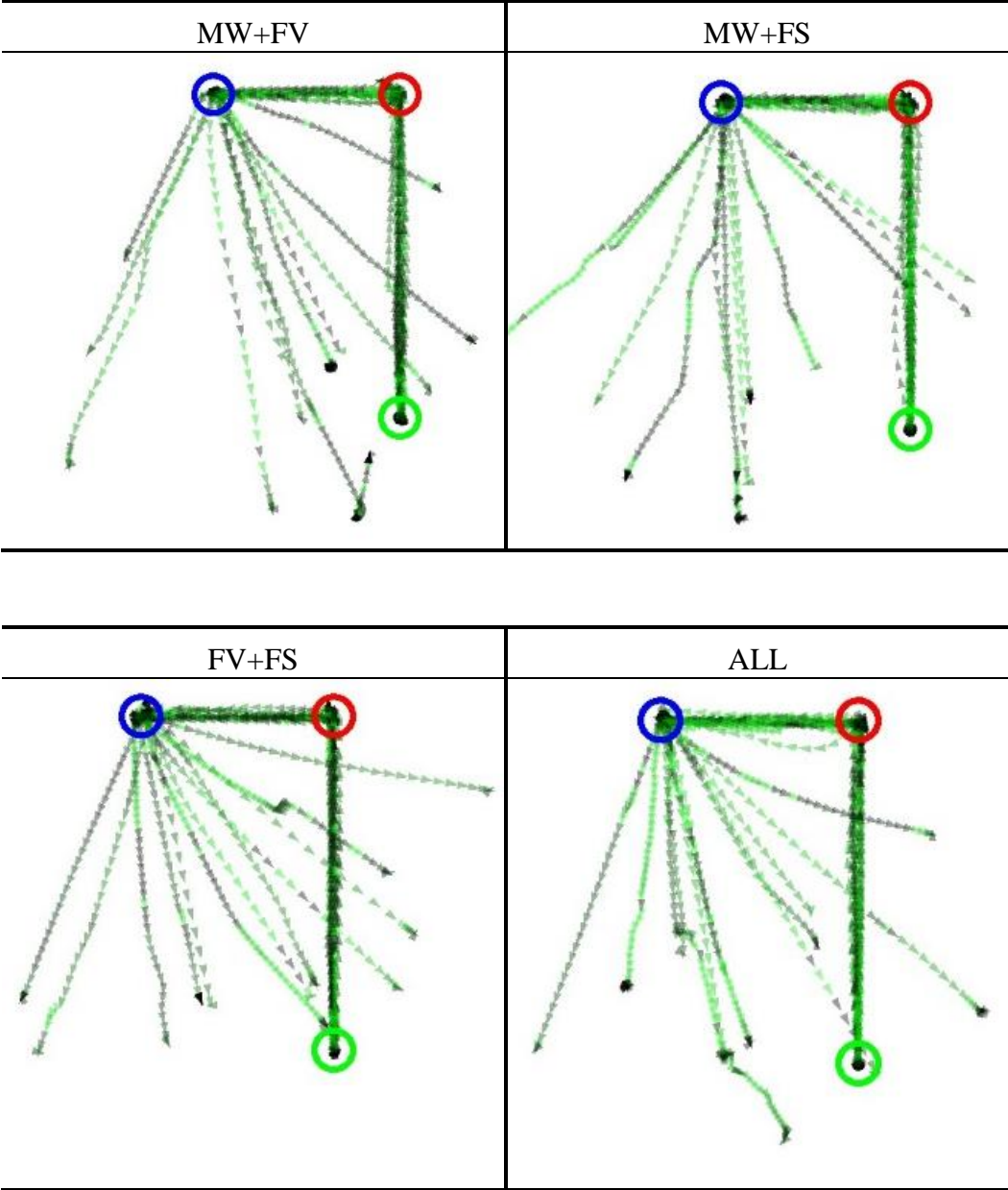

Main Experiment – Triangle Path 7

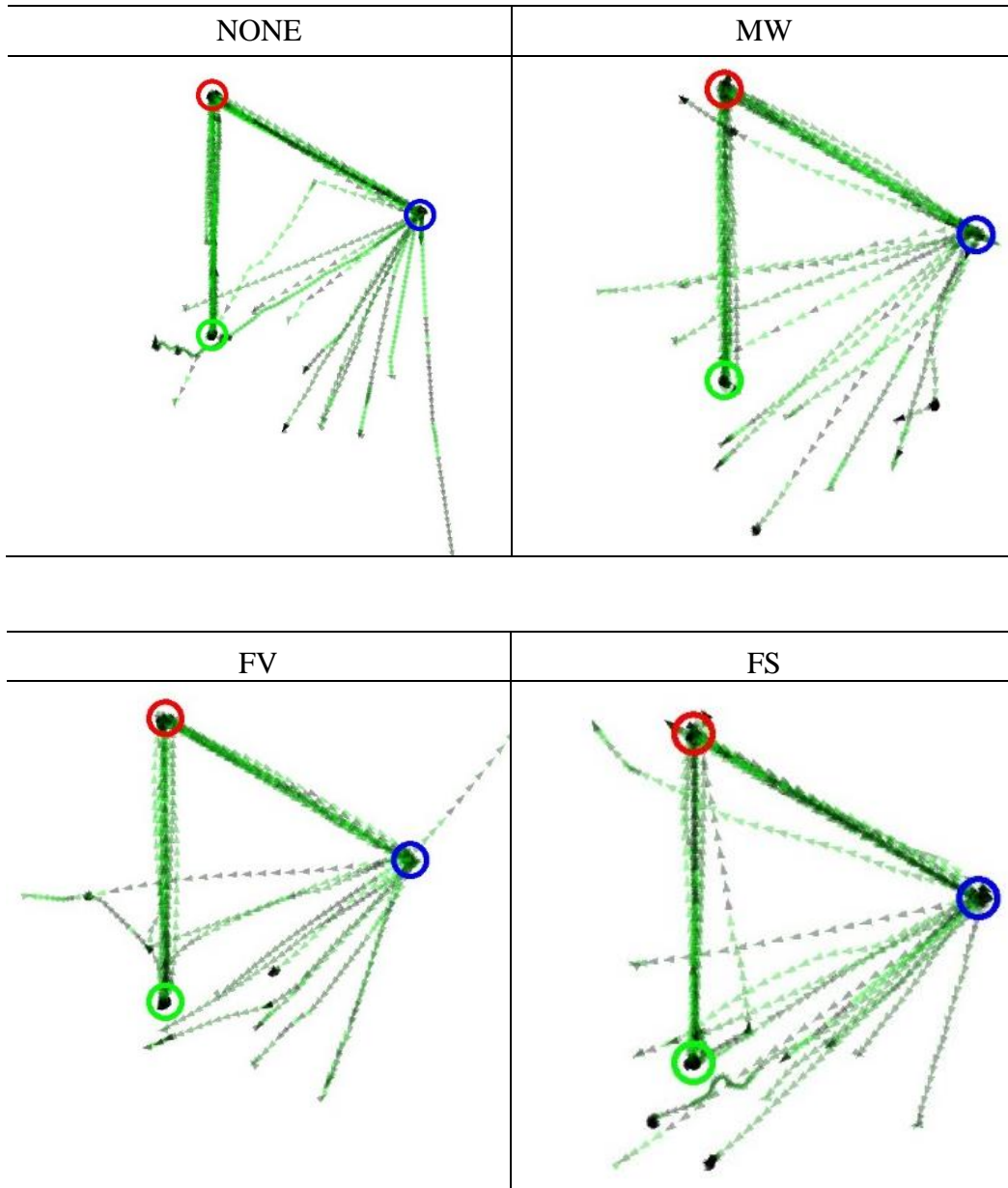

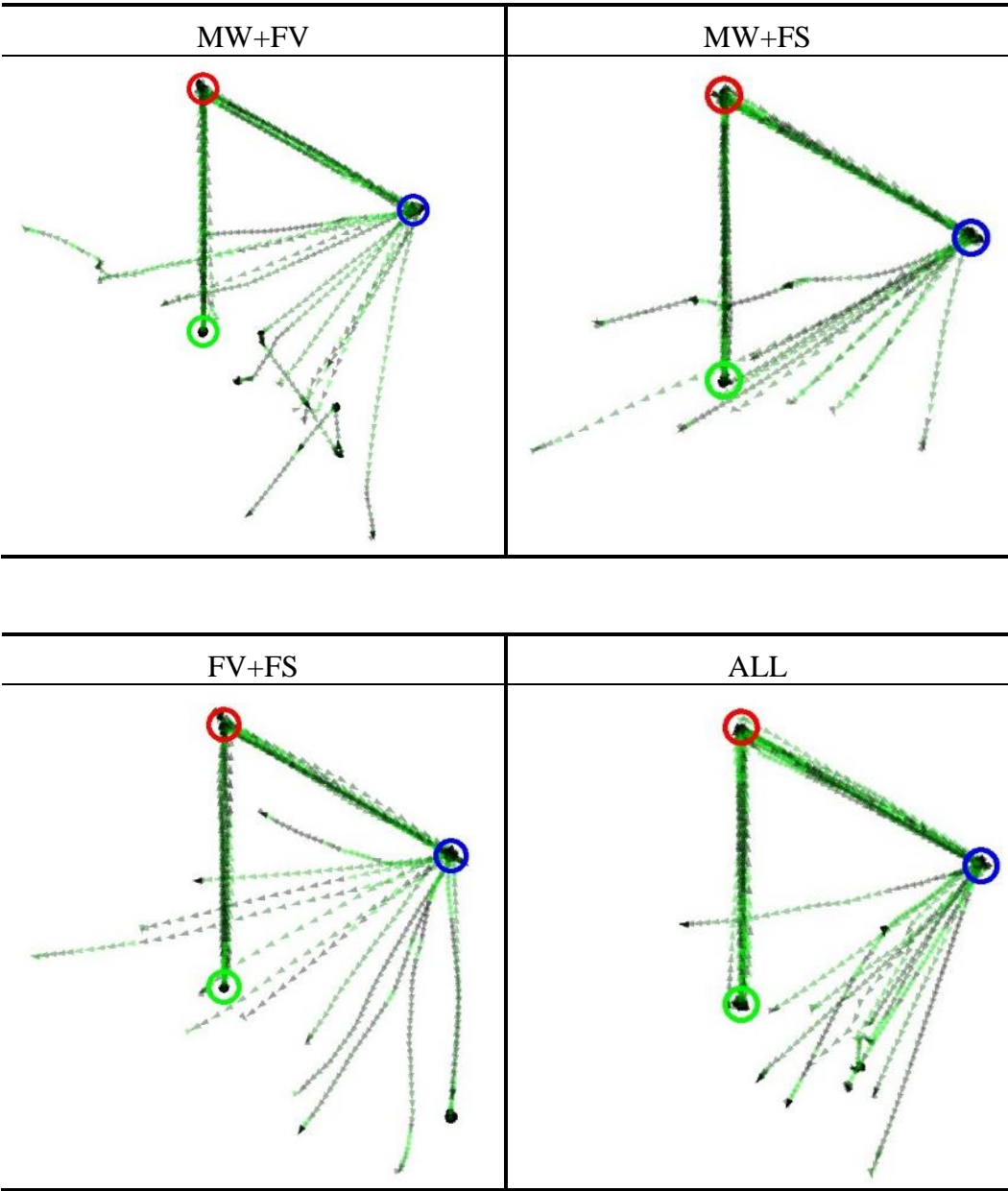

Main Experiment – Triangle Path 8

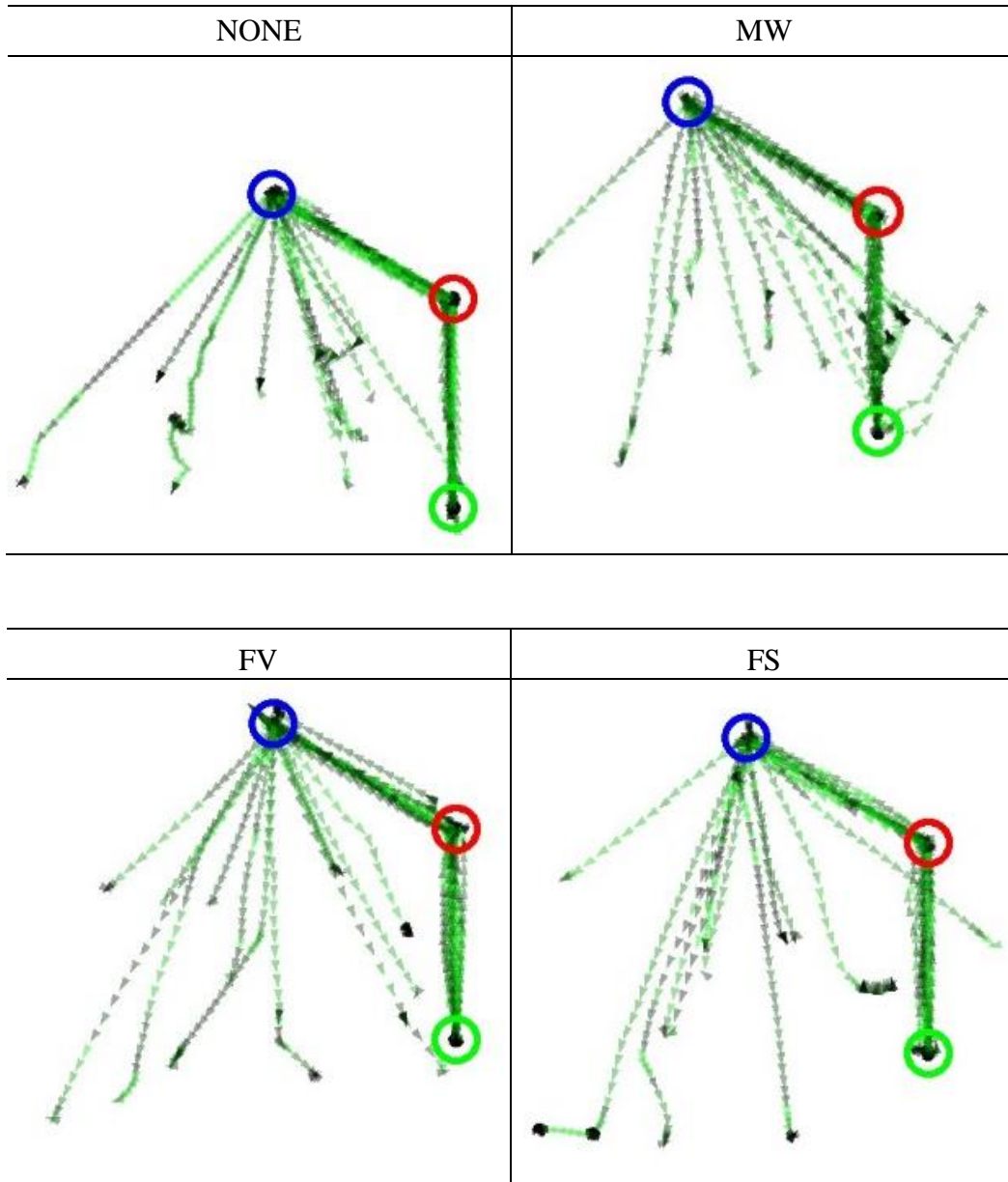

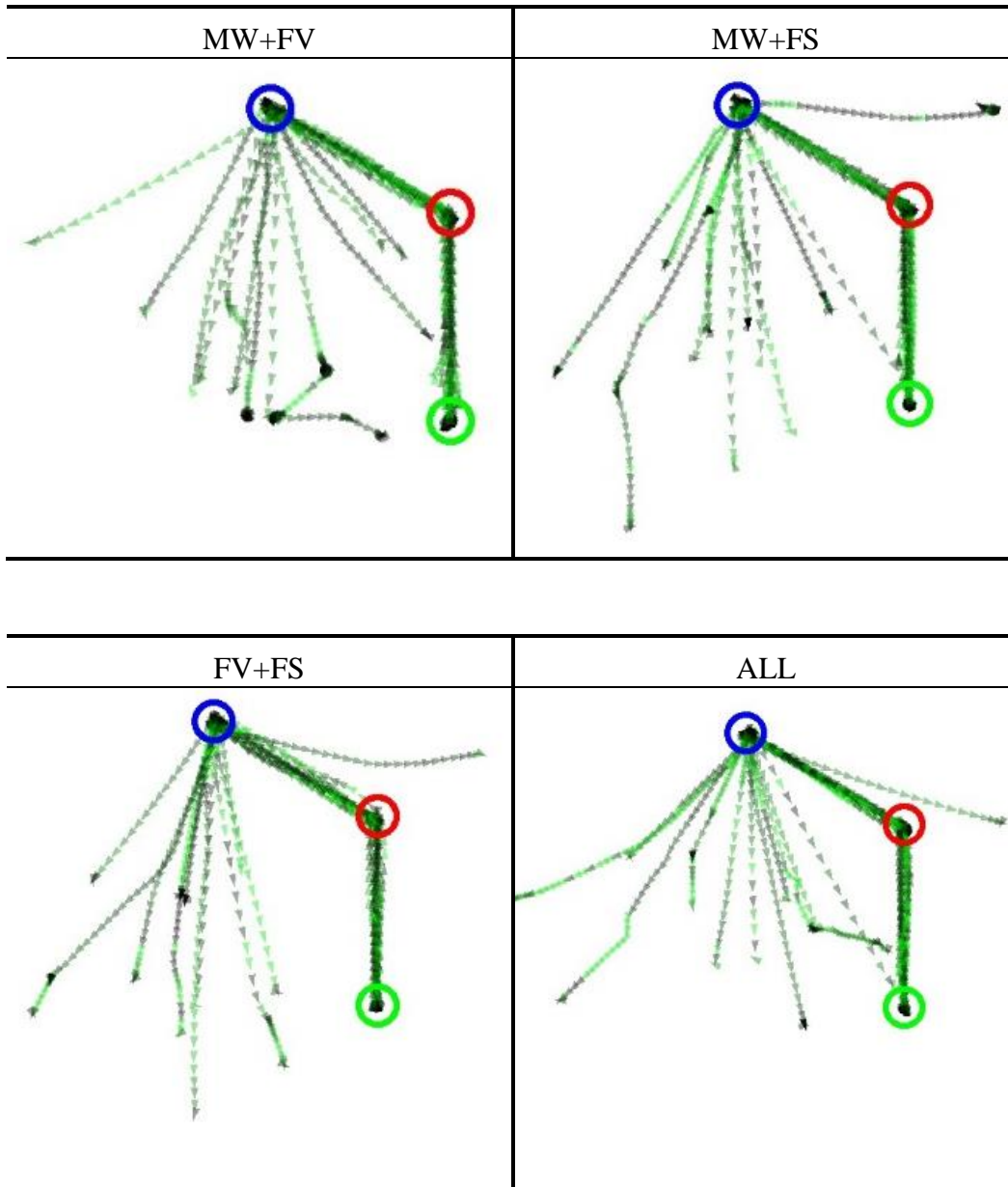

Follow-up Experiment – Triangle Path 1

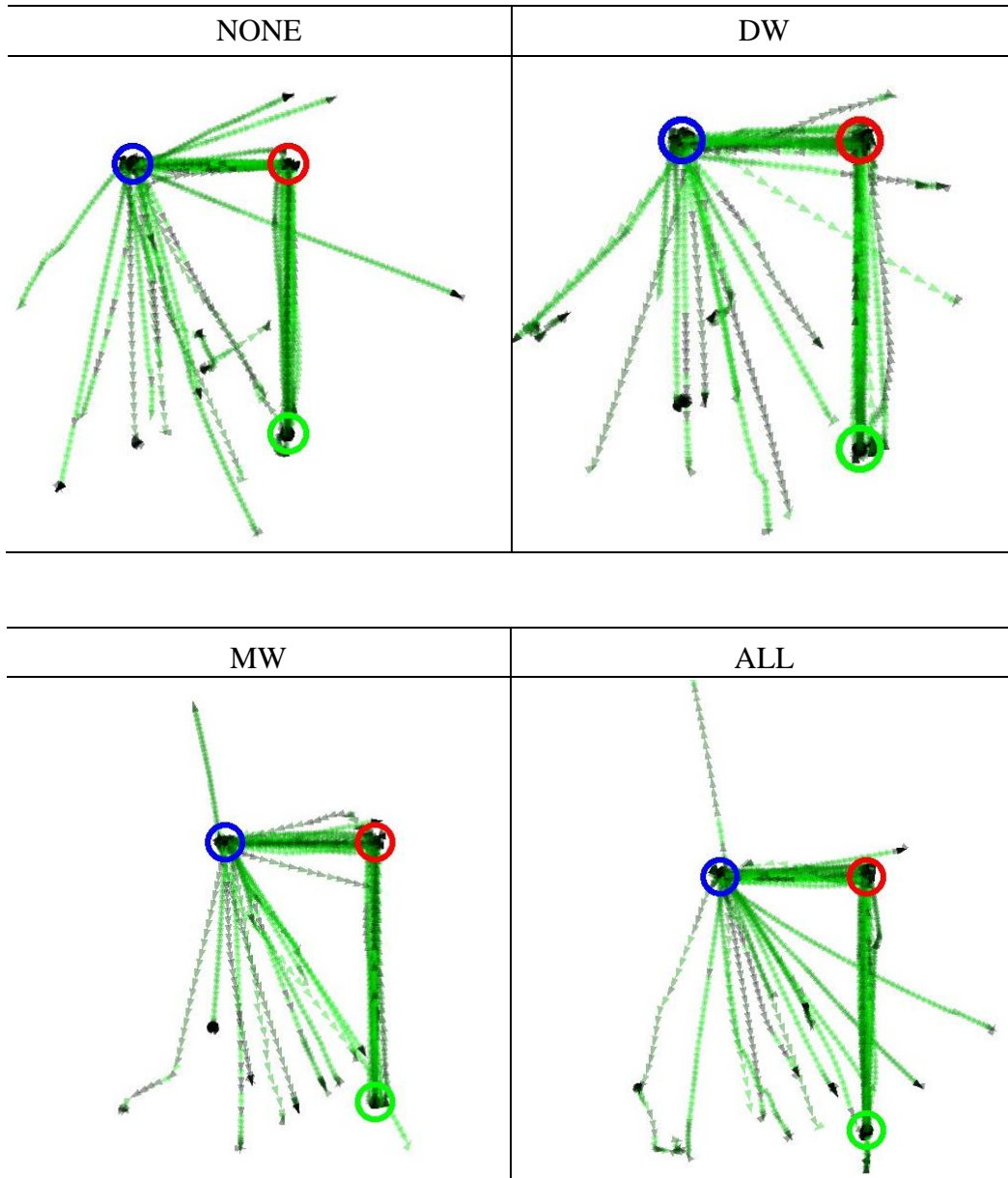

Follow-up Experiment – Triangle Path 2

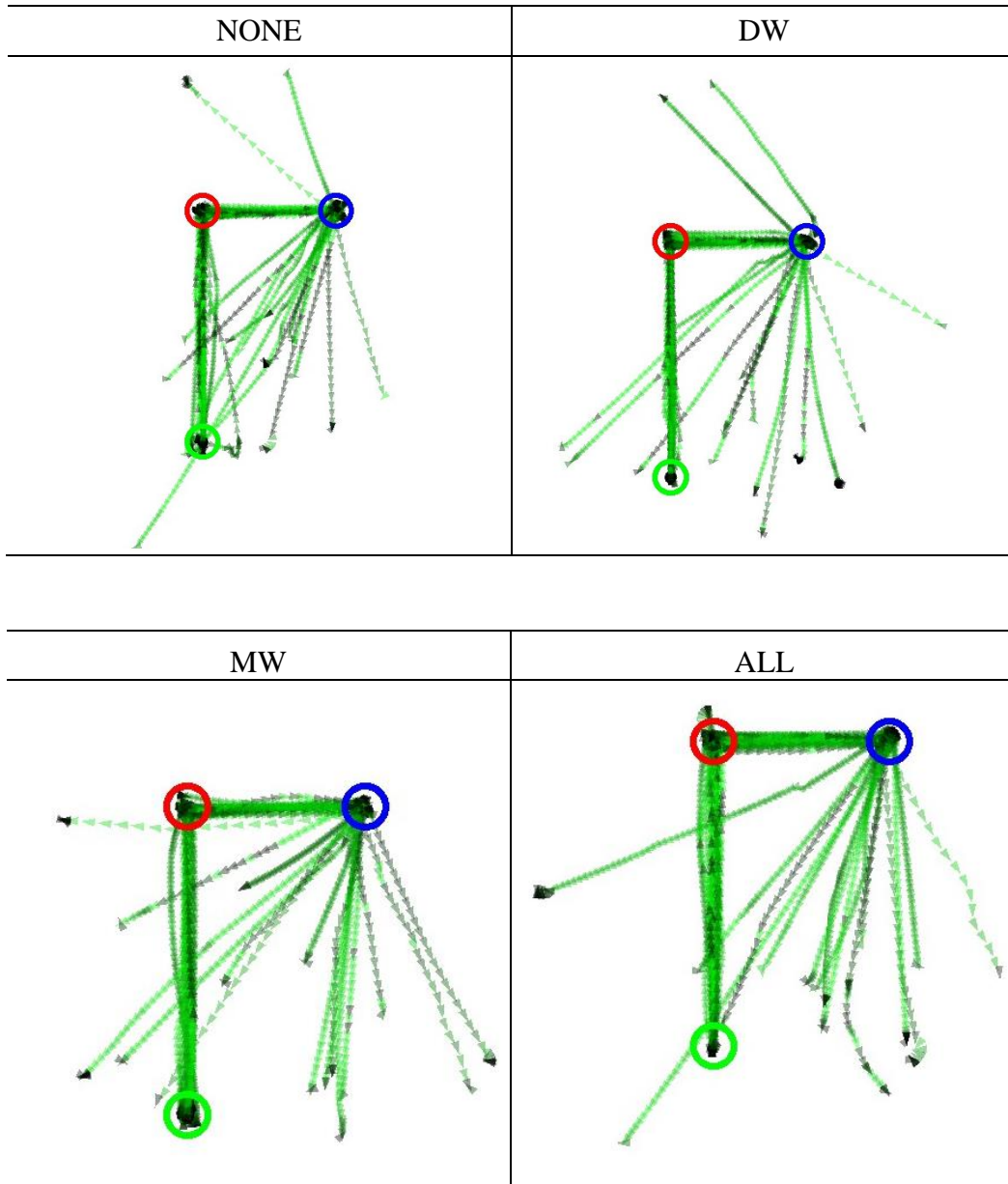

Follow-up Experiment – Triangle Path 3

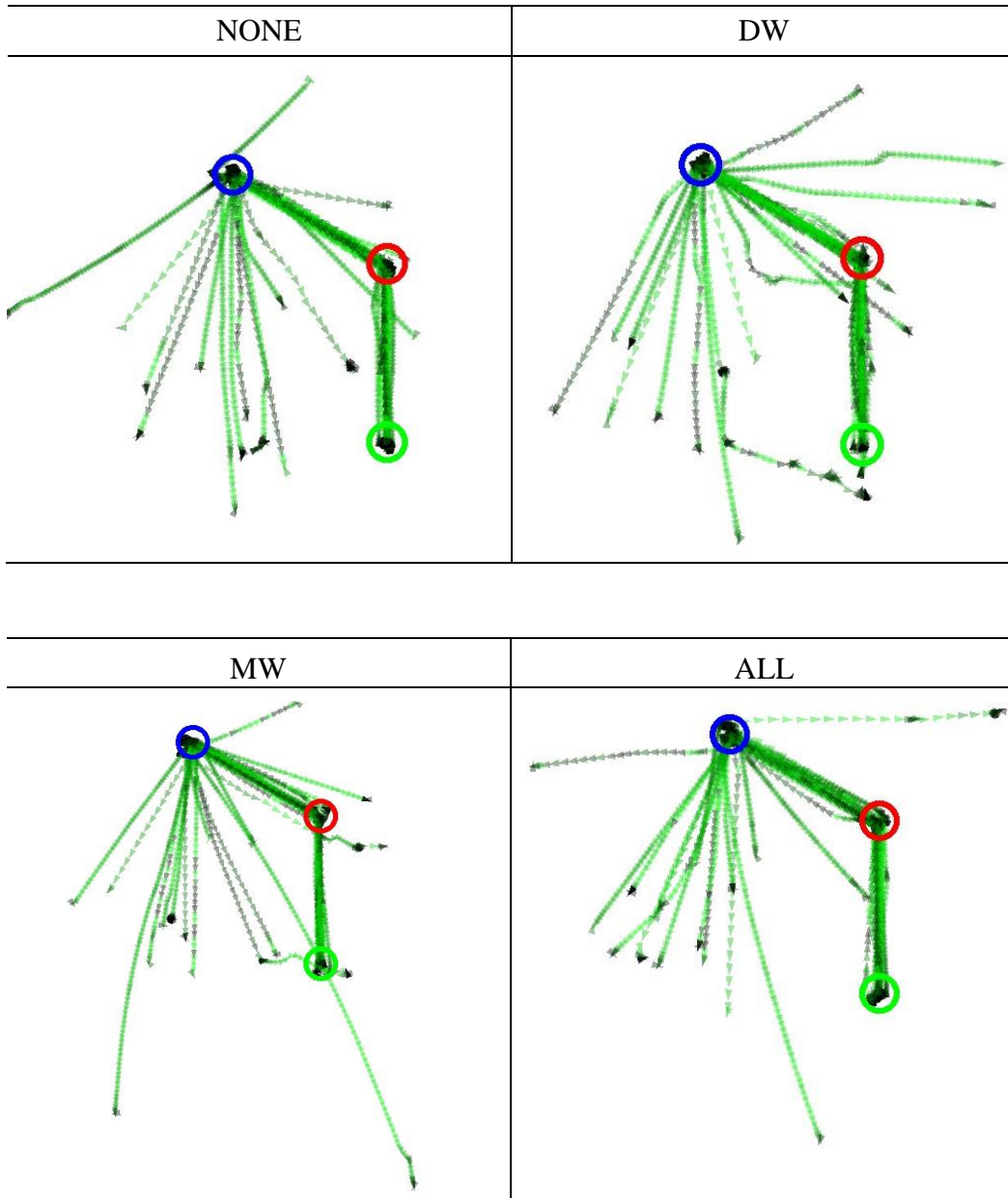

Follow-up Experiment – Triangle Path 4

