

December 2018

Structural Design of a Geodesic-inspired Structure for Oculus: Solar Decathlon Africa 2019

Alana Sher

Worcester Polytechnic Institute

Mary Sheehan

Worcester Polytechnic Institute

Sara Cardona

Worcester Polytechnic Institute

Follow this and additional works at: <https://digitalcommons.wpi.edu/mqp-all>

Repository Citation

Sher, A., Sheehan, M., & Cardona, S. (2018). *Structural Design of a Geodesic-inspired Structure for Oculus: Solar Decathlon Africa 2019*. Retrieved from <https://digitalcommons.wpi.edu/mqp-all/6694>

This Unrestricted is brought to you for free and open access by the Major Qualifying Projects at Digital WPI. It has been accepted for inclusion in Major Qualifying Projects (All Years) by an authorized administrator of Digital WPI. For more information, please contact digitalwpi@wpi.edu.



Structural Design of a Geodesic-inspired Structure for Oculus: Solar Decathlon Africa 2019

A Major Qualifying Project submitted to the faculty of
WORCESTER POLYTECHNIC INSTITUTE
in partial fulfillment of the requirements for the Degree of Bachelor of Science

Submitted By:

Sara Cardona
Mary Sheehan
Alana Sher

December 14, 2018

Submitted To:

Tahar El-Korchi
Nima Rahbar
Steven Van Dessel

Abstract

The goal of this project was to create the structural design for a lightweight dome frame structure for the 2019 Solar Decathlon Africa competition in Morocco. The design consisted of developing member sizes and joint connections using both wood and steel. In order to create an innovative and competitive design we incorporated local construction materials and Moroccan architectural features. The result was a structure that would be a model for geodesic inspired homes that are adaptable and incorporate sustainable features.

Acknowledgements

Sincere thanks to our advisors Professors Tahar El-Korchi, Nima Rahbar, and Steven Van Dessel for providing us with feedback throughout our project process. Thank you to Professor Leonard Albano for assisting us with steel design and joint design calculations. Additionally, thank you to Kenza El-Korchi, a visiting student from Morocco, for helping with project coordination.

Authorship

This written report, as well as the design development process, was a collaborative effort. All team members, Sara Cardona, Mary Sheehan, and Alana Sher contributed equal efforts to this project.

Capstone Design Statement

This Major Qualifying Project (MQP) investigated the structural design of a lightweight geodesic-dome inspired structure for the Solar Decathlon Africa 2019 competition. The main design components of this project included: member sizing and verification using a steel and wood buckling analysis, and joint sizing using shear and bearing analysis.

Steel Design

In order to conduct the steel buckling analysis, we utilized the American Institute of Steel Construction (AISC) provisions for column design. During this process, we calculated Euler's Critical Stress in order to compare this value to the axial stress calculated from the internal forces provided by RISA 3D with the area of the members. This process was done for every member that was in compression. For the members in tension, tension and fracture checks were conducted. During this process, we calculated the maximum load a member is capable of carrying and compared this to the applied load developed in RISA 3D. It was determined that a dome structure composed of members of A36 steel pipe with diameter 63.54mm and wall thickness 6.364mm pass the buckling, tension, and fracture checks.

Wood Design

In order to conduct the wood buckling check, we utilized the National Design Specification (NDS) Design Values for Wood Construction. The first step in this process was determining the load adjustment factors for Douglas Fir-Larch. Based on these factors, the maximum load capacity of the members was determined. These values were then compared to the internal member loads generated by RISA 3D. It was determined that a dome structure composed of members of 4x4 inches pass the buckling check.

Joint Design

When creating the design of joints, we analyzed the shear capacities of the bolt, steel plate and wooden member to ensure there would not be any failure. We also analyzed the joint for bearing, fracture and yield strength. This procedure was done for steel to steel, steel to wood and wood to wood connection. It was determined that a 5/8 inch, grade 325, bolt was needed for both steel to steel and wood to steel connections.

Constructability

This dome structure was designed with the intention of having a modular and prefabricated design. For both the wood and steel design, all members in the structure are the same size, thereby simplifying the manufacturing process. Additionally, the openings in the structure for the windows and doors fit into the existing geodesic pattern with only slight modification to the original design in order to incorporate the door frame.

Units

Throughout this report, both imperial and metric units were utilized. In order to comply with the American National Design Specification for Wood Construction, all calculations regarding wood were done using imperial units. The bolt sizes were also determined using imperial units since standard U.S bolt catalogs were used as a reference. For convenience, all

other calculations not involving wood including load calculations, shear capacity, buckling of steel, tributary area and loads by joint were done using metric units. The benefit of using metric units, where applicable, is that the design calculations will be more easily transferable with our Moroccan counterparts and our design will be easier to implement in other countries.

Safety

To ensure structural stability of the dome, and the ability for the dome to be constructed in a variety of different locations, the ASCE 7-10 code was used. This code accounts for loading, such as seismic and snow, that is not accounted for in the Moroccan Code. This creates a conservative design that can be implemented in many different locations, in addition to Morocco.

Executive Summary

Introduction and Background

The Solar Decathlon is a biennial collegiate competition that is hosted by the U.S Department of Energy in various locations across the globe. In September of 2019, the competition will be held in Ben Guerir, Morocco. The challenge of the competition is to create an innovative and sustainable design for a net-zero house that is powered by renewable energy. The purpose of the competition is to increase the knowledge and use of renewable energy throughout the public sector of Morocco. The competition creates a platform which encourages cross-cultural collaboration and enables students, educators, and locals to develop a cohesive design while gaining an understanding of sustainable design, increasing knowledge and encouraging the potential use of renewable energy. Additionally, the competition creates a true to scale home, enabling individuals to better interact and understand the use of sustainable materials and designs (About Solar Decathlon, 2018).

Our team for the Solar Decathlon, Team Oculus, consists of students from Worcester Polytechnic Institute (WPI) in Worcester, MA, USA, École nationale supérieure d'arts et métierstwo (ENSAM) in Rabat, Morocco, École nationale supérieure d'arts et métierstwo (ENSAM) in Meknes, Morocco, and the African University of Science and Technology (AUST) in Abuja, Nigeria. The WPI portion of the team is comprised of three different MQP teams, our MQP team specifically focused on the structural design of the building frame. The two other MQP teams focused on the building envelope and mechanical and electrical systems. Throughout the development of the design, the WPI team collaborated with the Moroccan team to verify the accuracy of their results and work toward a cohesive design.

Team Oculus aimed to design an innovative, net-zero, geodesic dome inspired design. The dome design maximizes the internal space of a structure while minimizing the self-weight. Geodesic domes can be built relatively quickly while using a variety of materials and are known for their ability to withstand severe loading conditions. The benefit of a geodesic design for the competition is that it can be adopted into many different cultures and locations around the world due to the flexibility of the design. The primary inspiration for the dome design was creating a home that could be marketed towards Eco-Tourism. Tourism is a driving factor of the Moroccan economy, and the Moroccan Ministry of Tourism, hopes that Morocco will be one of the world's top twenty destinations and become a model for sustainable design throughout the Mediterranean. Therefore, our goal was to design a home that supports natural environments and local economies through the representation of Moroccan culture in architectural features (Roudies, 2013).

Methodology

The development process for the structural design consisted of two main phases. During A term, our team primarily focused on the design of the dome. This was an iterative process done using AutoCAD and RISA 3D. During B term, our team focused on verification of the design, using both RISA 3D and Microsoft Excel. The initial design of the structure was a ribbed dome structure which had a base of 10 meters and height of 7.5 meters. The dome consisted of six curved members that were divided into 10 equal sections and modeled as linear members in RISA 3D. The next iteration, which incorporated a triangular member design, was a geodesic-dome inspired structure. We were provided with specifications from the architectural team

regarding the number of footings, height, and area requirements. The base of the design has 12 sides and a diameter of 9.6 meters. The shape increased in height through increments of 1.2 meters to reach a total height of 3.6 meters. As each layer was added, the level was shifted 15 degrees about the origin (0,0,0). Once all of the levels were created, each level was connected by a series of diagonals. Additionally, in order to maintain the structural stability of the dome, a triangle was added to the opening in the roof to support lateral loading. In the final iteration of the design, we removed the triangle from the top of the dome in order to create a completely open sky light. After testing the design without the triangle, we found that the model was not stable. In order to improve the structural stability, we added a compression ring at the top which consisted of members that have no moment release. This created stability for the structure because it inhibited lateral movement and resisted the wind and earthquake load on the structure. In order to create a more aesthetic shape of the dome, the diameter of the first layer was increased to 11 meters and a fifth layer was added to the dome. After the shape of the design was finalized, two doors were incorporated into the design. The first door was added by removing one of the members from Level 2 and moving two Diagonal 1's in order to create a base door opening of 1.2 meters. The same procedure was done at an angle of 120 degrees to create the second door.

The design of the dome structure is based on the ASCE 7-10 Load and Resistance Factor Design (LRFD). In order to determine the size of the wood members, the National Design Specification for Wood Construction was consulted. A dead load, seismic load, snow load, and wind load were applied to the structure and determined using ASCE 7-10. Due to the fact that ASCE 7-10 applies to areas within the U.S, we researched locations in the U.S. that would have similar natural conditions and used this in combination with the information given by the code to determine a snow load. The wind load was calculated by estimating a peak wind speed using the Beaufort Wind Scale and the Seismic load was determined by researching the average peak acceleration of earthquakes in Morocco. These loads were then applied to the structure in RISA 3D.

The next step was to research possible materials that could be used for construction. In order to determine the most ideal member sizes, both wood and steel designs were analyzed. We considered A36 steel and Douglas Fir-Larch for the member materials. A36 steel is a common structural steel that is used for construction throughout the U.S. We considered using A36 steel as a building material because of its high strength and formability. Douglas Fir-Larch was considered as the second option for a building material. Douglas Fir-Larch is one of the most popular wood building materials among architects, engineers and contractors. It is known for its high strength to weight ratio and ability to withstand wind, rain and snow. Douglas Fir-Larch is known for being one of the most durable and strongest woods of the softwood classification (Douglas Fir-Larch).

We used RISA 3D, a structural analysis software which is useful in determining member sizes and internal forces in members. In order to determine the necessary member sizes using RISA 3D, we used the member force outputs, which provided the axial force per member. We decided that it would be best to use HSS as the designated shape for steel and a standard rectangular cross section for wood. Once the shape was determined we analyzed the axial load outputs to gain a better understanding of the required cross-sectional area and moment of inertia. Ultimately, we decided it would be best to have a small diameter with larger wall thickness, because it would prevent local buckling of the members and allow the team for ease of construction.

We developed a Microsoft Excel spreadsheet to verify the p-delta check that RISA 3D runs for buckling in its members in order to prevent failure. We later consulted the National Design Specification- Design Values for Wood Construction and The American Institute for Steel Construction (AISC) to determine the allowable internal forces in each member. We then compared it to the output internal force from RISA 3D in each member to check that these could support their internal forces.

Results and Discussion

Steel

Once the RISA 3D model was solved, we were able to find the member and reaction forces. RISA 3D presented us with information regarding the axial, shear, torque and moments within each member. The axial forces ranged significantly with the largest tensile force being 62.41 kN and the largest compressive force was 64.12 kN. The Microsoft Excel sheet was used to determine if there was failure in the members. If the calculated actual stress was less than the critical stress, then the member did not buckle. According to our calculations, the smallest steel member size that passed the buckling check was a 62.54 mm diameter HSS pipe with a wall thickness of 6.364 mm.

Wood

After solving for the steel, the RISA 3D model was resolved three times for different wood sizes, which were with a 2x section, 3x section and 4x section. The model provided us with results pertaining to joint reactions deflections and member forces, among others. These results gave us information about the stability of the model and its behavior. It was determined that for the 2x model, the largest tensile force was 58.27 kN and the largest compressive force was 60.05 kN. For the 3x model the largest tensile force was 58.29 kN and the largest compressive force was 60.13 kN. For the 4x model the largest tensile force was 57.62 kN and the largest compressive force was 59.20 kN. After solving for the buckling check in Microsoft Excel, we were then able to determine the percent failure of each member. When using 2x12 and 2x10 inch members, 20 out of 178 members failed and 8 out of these 20 members failed by a magnitude of over 100 percent. The 3x8 and 3x6 inch structure had 3 of 178 members fail, and the largest failure was 15 percent. The last model tested was the 4x4 inch model, and no members failed.

Recommendations and Conclusion

Based on the RISA 3D modeling and Microsoft Excel spreadsheet calculations, we were able to find two final designs that were structurally stable and unique. We originally modeled the design in both wood and steel in hopes of finding a model that was structurally stable, had ideal member sizing and was made from sustainable material. After considering each material and design parameters, we determined the 4x4 inch wood design model was the best option. Wood is more sustainable, lightweight and easier to prefabricate into unique members.

Table of Contents

Abstract.....	ii
Acknowledgements.....	vi
Authorship.....	vii
Capstone Design Statement.....	v
Executive Summary.....	vi
Table of Contents.....	ix
List of Figures & Tables.....	x
Chapter 1: Introduction.....	2
Chapter 2: Background.....	5
2.1 History of Solar Decathlon.....	5
2.2 Addressing a need in Morocco.....	6
2.3 Design Development of House.....	7
2.4 Study of Geodesic-Inspired Dome Design.....	7
2.5 Loading Development and Code.....	8
2.6 Materials.....	11
Chapter 3: Methodology.....	12
3.1 Project Timeline.....	12
3.2 Design Iterations.....	13
3.3 Developing Loads and Loading Combinations.....	23
3.4 Calculating Tributary Area.....	20
3.5 Risa 3D Modeling.....	21
3.6 Member Design and Analysis.....	23
3.7 Member Buckling Check.....	23
3.8 Joint Design.....	27
3.9 Creating a Dome Prototype.....	28
Chapter 4: Results and Discussion.....	30
4.1 Wood Structure Design.....	30
4.2 Steel Structure Design.....	31
4.3 Risa 3D Modeling.....	32
4.4 Comparison with Moroccan Team.....	35
4.5 Bolt Design.....	36
4.6 Shear Analysis for Steel Joint and Steel Member.....	37
4.7 Shear Analysis for Steel Joint and Wood Members.....	38
4.8 Shear Analysis for Wood Joint and Wood Members.....	39
Chapter 5: Recommendations and Conclusion.....	40
References.....	43
Appendix A: Member Properties.....	44
Appendix B: Seismic Load Calculation.....	52
Appendix C: Tributary Area Calculations.....	53
Appendix D: Factored Load Combinations.....	54
Appendix E: Loads Applied at Each Joint.....	55
Appendix F: Bucking Analysis Example for Douglas-Fir Larch.....	58
Deliverables.....	Attached separate from report

List of Figures and Tables

Figures

Figure 1: Site of 2019 Solar Decathlon in Ben Geurir, Morocco (Sher, 2018).....	6
Figure 2: Traditional Geodesic Dome.....	8
Figure 3: ASCE 7-10 Basic Load Combinations (ASCE 7-10, 2010).....	8
Figure 4: Seismic peak hazard map (Cherkaoui & El Hassani, 2012).....	9
Figure 5: Ground snow load (ASCE 7-10, 2010)	10
Figure 6: Gantt Chart.....	12
Figure 7: Design A.....	13
Figure 8: Design B, profile view, shown in meters.....	14
Figure 9: Design B, plan view.....	14
Figure 10: Design B, 3D view.....	15
Figure 11: Design C, profile view, shown in meters.....	16
Figure 12: Design C, plan view.....	17
Figure 13: Design C, 3D view.....	17
Figure 14: Tributary Areas as drawn in AutoCAD.....	21
Figure 15: Flow Chart for Risa 3D processes.....	22
Figure 16: Equation for C_p adjustment factor.....	25
Figure 17: Equation for moment of inertia for pipe.....	25
Figure 18: Double shear failure modes.....	28
Figure 19: Dome prototype (Sheehan, 2018)	23
Figure 20: Member lengths and range of axial loads.....	32
Figure 21: Axial forces in 2x12 and 2x10 wood designs.....	33
Figure 22: Axial forces in 3x6 and 3x8 wood designs.....	33
Figure 23: Axial forces in 4x4 wood design.....	34
Figure 24: Axial forces in steel design.....	34
Figure 25: Member labels.....	35
Figure 26: Connection design, shown in inches.....	38
Figure 27: Steel to steel connection bolt layout, shown in inches.....	41
Figure 28: Steel to wood connection bolt layout, shown in inches.....	41

Tables

Table 1: NDS properties for wood design (NDS, 2005).....	24
Table 2: AISC properties for steel design (AISC, 1994).....	26
Table 3: Equations for steel buckling check (ASCE 7-10, 2010).....	26
Table 4: Tension and fracture check for steel (site)	27
Table 5: Results for steel and wood designs.....	31
Table 6: Result comparison with Moroccan team.....	36
Table 7: Results for bolt design.....	37
Table 8: Results for steel joints and steel members.....	37
Table 9: Results for steel joints and wood members.....	38
Table 10: Results for wood joint and wood members.....	39
Table 11: Steel results.....	40
Table 12: Wood Results.....	40
Table 13: Design criteria for Professional Engineer to review.....	42

Chapter 1: Introduction

Solar Decathlon Competition

The Solar Decathlon is a biennial collegiate competition hosted by the U.S. Department of Energy. The competition is held in various locations across the globe and has currently been held in eight different countries since it began in 2002. This year the competition is being held in Ben Geurir, Morocco. There will be 20 multidisciplinary teams competing. Each team consists of students from different cultural and educational backgrounds. The challenge of the competition is to create an innovative and sustainable house that is powered by renewable energy. The houses are then judged based on 10 contest criteria. The guidelines specific to the Moroccan Solar Decathlon are to create a low energy-consuming building while also integrating regional sustainable building materials within the design (About Solar Decathlon, 2018).

The purpose of the competition is to encourage cross-cultural collaboration and enable students, educators, and locals to gain an understanding of sustainable design and therefore increase knowledge and potential use of renewable energy. In Morocco, there is currently a need to increase knowledge and use of renewable energy and construction techniques. Therefore, the Solar Decathlon will promote awareness and educate the public about the benefits of renewable and sustainable technologies. The construction of solar homes for the competition in Morocco will demonstrate the comfortability, feasibility and convenience of a solar home to visitors and locals throughout the region. By designing and building homes for the competition, students will provide a model home for people to interact with and utilize to better understand the features and benefits of a net-zero solar powered home. This competition also creates a hands-on educational opportunity for college students to contribute to impactful projects on a global level. Students participating will have the opportunity to learn how to work on a multidisciplinary team, collaborate with others to create a design, and construct the design for the final competition (About Solar Decathlon, 2018).

Scope of Project

Our team for the Solar Decathlon, Team Oculus, consists of students from Worcester Polytechnic Institute (WPI) in Worcester, MA, USA, École nationale supérieure d'arts et métierstwo (ENSAM) in Rabat, Morocco, École nationale supérieure d'arts et métierstwo

(ENSAM) in Meknes, Morocco, and the African University of Science and Technology (AUST) in Abuja, Nigeria. The WPI portion of the team consists of three different MQP teams, which cover the architectural, structural, and mechanical designs of the house. Specifically, our MQP team worked on the structural design of the building frame. This project presented a new and unique challenge for our group. In addition to performing the structural analysis for the design of the home, we maintained constant collaboration with the other teams, in order to ensure the cohesiveness of our designs.

In order to carry out the structural analysis of the house, we utilized AutoCAD to draft the design and RISA 3D to perform the analysis of the structure. To perform the analysis portion of the project we determined the loads that would be applied to the structure by following the American Society of Civil Engineers (ASCE) 7-10 code using locations in the U.S that have similar environmental conditions and weather patterns to Ben Guerir, Morocco. The analysis was used as a tool to develop the internal forces of every member. These forces were then used to develop member sizing and joint design.

Geodesic Dome Inspired Structure

Team Oculus aims to present an innovative net-zero, solar powered home for the 2019 Solar Decathlon Africa competition. Our unique design is a geodesic dome inspired structure. A geodesic dome typically consists of equal linear members, which are able to achieve a large span without requiring internal supports. Geodesic domes are used frequently in agricultural applications due to their ability to be constructed in a short amount of time with a wide range of materials as well as for their resilience in natural disasters. After researching different types of domes, we concluded that a dome would function as the best design for our home since it has the ability to incorporate the aesthetic of Moroccan architecture, efficient energy usage, and evaporative cooling techniques.

Project Implications and Possible Impact

The net zero solar powered house created by our team is designed to be marketed towards Ecotourism. Ecotourism is tourism inclined towards exploring natural environments while making efforts to conserve and protect the wildlife and ecosystems of those environments. Tourism is considered a powerful driver of economic growth, especially in the Moroccan

economy. According to an initiative created by the Moroccan Ministry of Tourism, their vision for 2020 was to push Morocco to be one of the world's top twenty destinations, and to be "a model for sustainability in the Mediterranean." In order to do this, they promoted five fundamental principles which included marketing the variety of resources that the local markets have to offer and "putting sustainable development at the heart of their strategy" (Roudies, 2013). Our vision for the design and market appeal of the solar home is parallel with the Moroccan Ministry of Tourism's vision for ecotourism. The design of our solar home incorporates Moroccan designs as well as architectural features that make use of the local trade and resources in the area. Overall, Team Oculus's aim is to create a house that will service African communities by providing ecotourism opportunities where tourists can experience and appreciate without disturbing the local community.

Chapter 2: Background

2.1 History of the Solar Decathlon

The Solar Decathlon originally began in 2002 and was hosted at the National Mall in Washington, D.C. 14 teams from across the U.S participated in the competition. In 2005, the competition was opened to international participants and has been occurring biennially across the globe ever since (About Solar Decathlon, 2018). According to the USDE, there are three main goals of this competition:

1. Provide participating students with unique training that prepares them for the clean energy workforce.
2. Educate students and the public about the latest technologies and materials in energy-efficient design, clean energy technologies, smart home solutions, water conservation measure, electric vehicles and sustainable buildings.
3. Demonstrate to the public the comfort and savings of homes that combine energy-efficient construction, design, and appliances with onsite renewable energy production.

As part of this competition, student teams collaborate to design and construct a full-scale solar-powered house. These houses are then on display for visitors and judges. The houses are judged based on 10 different contests and the overall success in combining “design excellence and smart energy production with innovation, market potential, and energy and water efficiency.” The contests consist of: architecture, engineering and construction, market appeal, comfort, conditions, appliances, sustainability, home life and entertainment, communication and social awareness, electrical energy and balance, and innovation (About Solar Decathlon, 2018). Over the course of the past 16 years, over 18,000 collegiate students have participated on over 150 teams. Although this competition began in the U.S, it has expanded to involve Europe, Asia, Latin America, Africa, and the Middle East (About Solar Decathlon, 2018).

On November 15, 2016 at the Marrakech Climate Change Conference, the Moroccan Ministry of Energy, Mines and Sustainable Development, the Moroccan Research Institute in Solar Energy and New Energies (IRESEN), and the U.S. Department of Energy signed a memorandum of understanding to develop the Solar Decathlon Africa. As a result, 20 teams

consisting of both Moroccan and international students will be competing in the Solar Decathlon 2019 which will be held in Ben Guerir, Morocco (About Solar Decathlon, 2018).



Figure 1: Site of 2019 Solar Decathlon in Ben Guerir, Morocco (Sher, 2018)

2.2 Addressing a need in Morocco

In order to begin to develop a truly innovative and beneficial home, we first needed to identify a potential need for a net-zero home in Morocco. Eco-tourism has become a crucial part of developing the economy in Morocco. In 2013, the Moroccan Ministry of Tourism published the “Vision 2020 for Tourism in Morocco: Focus on Sustainability and Ecotourism.” Part of this framework is developing eight unique tourist destinations throughout Morocco: The Northern Cape, Mediterranean Morocco, the Center of Morocco, Central Atlantic, Atlas & the Valleys, Souss Sahara Atlantic, and the Great Southern Atlantic Coast. In developing these destinations, the Moroccan Ministry of Tourism seeks to do so in a way that guarantees the preservation and conservation of natural resources, addresses the social and environmental sensitivities of tourists, and develops sustainability as a defining feature of Morocco (Roudies, 2013).

2.3 Design Development of House

To address the need for sustainable eco-tourism in Morocco, we have developed a modular design for a geodesic dome-inspired home. The structural frame consists of a dodecagon shaped base and five dodecagon-shaped layers above the base. Each layer is rotated 15 degrees and then connected to the layer below at the joints. This creates the triangulations throughout the structure. There is a total of 178 linear members and 74 joints. The base of the structure has a diameter of 9.6 meters and the structure has a total height of 3.6 meters. The simplicity of this frame allows for it to be complemented with local materials for the building envelope and architectural features so a unique model can be constructed at each of the eight tourist destination in Morocco, as well as other various locations across the globe.

2.4 Study of Geodesic-Inspired Dome Design

The vision for this structure was a house that would provide that largest amount of unobstructed internal space thereby creating an open concept floor plan. This would create a space well-lit with natural light and enable ease of heating and cooling. In order to accomplish this structurally, we chose to design a dome structure, also known as a space frame. A space frame is a lightweight structure composed of truss elements that form a geometric pattern comprised of triangular members. As this is a truss system, all joints are considered hinged and therefore carry no internal moments. Therefore, this structure is statically indeterminate and difficult to analyze through hand calculations. These structures have become more popular with the introduction of computer software for finite element modeling (Wai-Fah, 1999).

This type of structure offers many unique benefits. The first is that the structure is very lightweight, especially when compared to traditional homes. Due to the truss structure, the load is transferred axially, both in tension and compression. Therefore, all of the members are utilized to their full capacity. Another benefit is that the structure can be prefabricated and therefore mass-produced. This is beneficial when it comes to transporting materials and constructing the dome on site in a short amount of time. Another benefit is that these structures are rigid and stiff. This provides great resistance to unsymmetrical loading. Another significant advantage of a space frame is that the structure is extremely versatile. This is appealing to architects because the dome can be produced as a standard module yet complemented with unique architectural features (Wai-Fah, 1999). A traditional geodesic dome consists of equal linear members, as shown in

Figure 2. However, in order to maximize the walkable internal space, we developed a structural system in which the widest diameter is not the base and the members are not all equal in size.

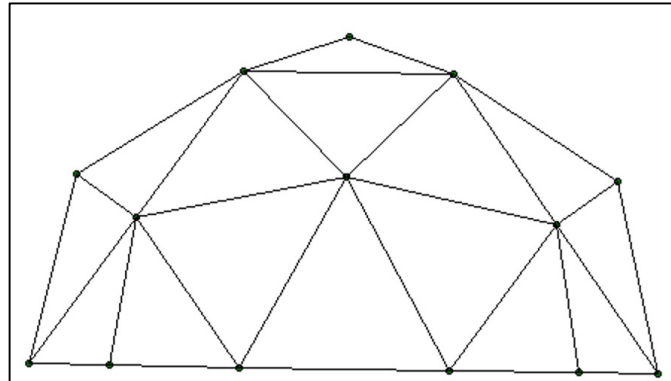

Figure 2: Traditional geodesic dome

2.4 Loading Development and Code

The design of the dome structure is based on the ASCE 7-10 Load and Resistance Factor Design (LRFD). It is useful in determining the requirements for the structural design, as well as providing a means to determine the load combinations. In order to determine the size of the wood members, the National Design Specification for Wood Construction was consulted.

ASCE 7-10

The code used for the structural design of the dome was American Society of Civil Engineers (ASCE) 7-10 Minimum Design Loads for Buildings and Other Structures. This code is based off of design strengths and allowable stress limits for conventional structural materials. The following loading combinations shown in Figure 3 were taken directly from ASCE 7-10 and the most severe loading case was used in the analysis of the dome.

- 1.) $1.4D$
- 2.) $1.2D + 1.6L + 0.5(L_r \text{ or } S \text{ or } R)$
- 3.) $1.2D + 1.6(L_r \text{ or } S \text{ or } R) + (L \text{ or } 0.5W)$
- 4.) $1.2D + 1.0W + L + 0.5(L_r \text{ or } S \text{ or } R)$
- 5.) $1.2D + 1.0E + L + 0.2S$
- 6.) $0.9D + 1.0W$
- 7.) $0.9D + 1.0E$

Figure 3: ASCE 7-10 Basic Load Combinations (ASCE 7-10, 2010)

National Design Standard for Wood Construction (NDS)

The National Design Standard for Wood Construction was consulted to determine the minimum sizing for the wood members. The NDS provided information regarding the adjustment factors of lumber, design values for specific wood types and equations regarding the sizing of members.

Seismic Load

In order to determine the seismic loading on the structure, we consulted ASCE 7-10 requirements for seismic loading. The first step was to determine the associated peak ground acceleration for the area of interest. In this case, the area of interest is Ben Guerir, Morocco. According to a report that the French National Center for Scientific Research created, the average peak ground acceleration for the area surrounding Ben Guerir was around 0.06g (Badrane, Bahi, & Najine, 2007). We were able to cross check the value for the average peak ground acceleration against another report by Cherlaoui & El Hassani, Seismicity and Seismic Hazard in Morocco 1901-2010. Figure 4 displays the seismic peak hazard map for the peak ground acceleration with 10% probability of exceedance in 50 years (Cherkaoui & El Hassani, 2012).

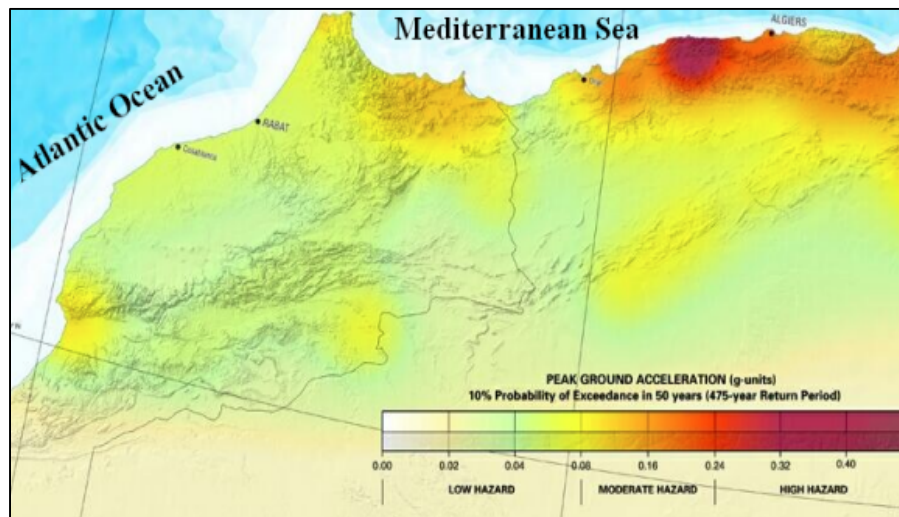

Figure 4: Seismic peak hazard map (Cherkaoui & El Hassani, 2012)

According to this map, the peak ground acceleration is estimated to be around 0.03g for Ben Guerir. Therefore, it was assumed that the peak ground acceleration would be an average of 0.045g and base shear was determined using the equation from ASCE 7-10.

Wind Load

For a conservative estimate of the wind speed applied to the structure, the Beaufort Wind Scale was consulted. The Beaufort Wind Scale is an empirical measure that relates wind speed to observed conditions. According to the Beaufort Wind Scale, 55 to 63 mph is a wind speed that causes considerable damage to buildings and can occur under conditions not directly related to hurricanes (Beaufort Wind Scale, n.d). Due to the fact that Ben Guerir, Morocco is not considered a hurricane prone zone, we assumed that the highest wind speeds they would normally experience would be smaller than 63 mph.

Snow Load

Although the Moroccan code does not include a snow load, to be conservative, we assumed a snow load similar to that in New Mexico, due to the similarities between their climate. Both Ben Geurir, Morocco and New Mexico have a moderate, continental climate. The value of the flat roof snow load (P_f), was calculated by using the ASCE 7-10 ground snow loads as shown in Figure 5.

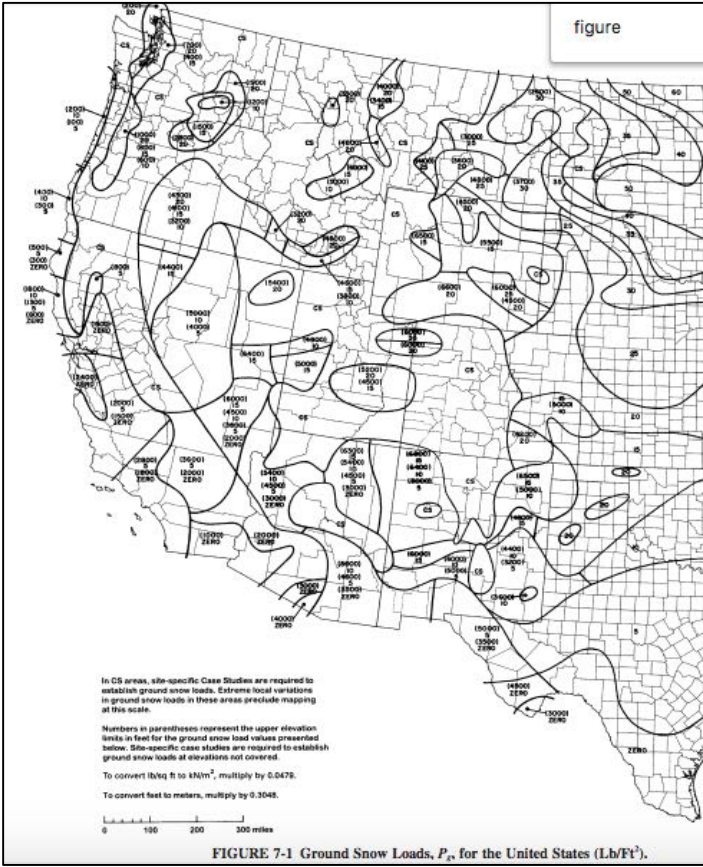

Figure 5: Ground snow load (ASCE 7-10, 2010)

Dead

The dead load is the weight of everything that contributes to the weight of the structure, including any architectural features, and permanent equipment. This includes the walls, ceiling, floor, and building envelope.

2.6 Materials

In order to determine the most ideal member sizes, both wood and steel designs were analyzed. We considered A36 steel and Douglas Fir-Larch for the member materials.

A36 Steel

A36 steel is a common structural steel that is used for construction throughout the U.S. We considered using A36 steel as the building material because of its high strength and formability. It is easy to prefabricate, which was one of the main requirements for the design, and it can also be securely welded to the joints or other members. The yield strength of A36 steel is 0.25 kN/mm² and the modulus of elasticity is 200 kN/mm². It is typically hot rolled, and can be made into a variety of different shapes, which is ideal for the design of the members.

Douglas Fir-Larch

Douglas Fir-Larch is one of the most popular wood building materials among architects, engineers and contractors. It has a high strength to weight ratio and ability to withstand wind, rain and snow. Douglas Fir-Larch is known for being one of the most durable and strongest woods of the soft wood classification. The modulus of elasticity for Douglas Fir-Larch is 1,600,000 psi and the bending stress is 900 psi. We chose to model the design with Douglas Fir-Larch due to its reliability and favorable properties. It is used as a building material throughout the U.S in both commercial and residential buildings. (Douglas Fir-Larch, U.S. Lumber)

Chapter 3: Methodology

3.1 Project Timeline

Our MQP was completed in A and B term. During A term, we focused on developing the design for the geodesic-dome inspired structure. The method of developing the AutoCAD model was an iterative process. The initial design was a ribbed dome. However, the architectural vision was shifted to a geodesic style to incorporate triangular structural elements into the façade. Initially, the base was 10 meters in diameter, however, this was altered to incorporate the architectural scale that consists of increments of 1.2 meters. Once the model was finalized in AutoCAD, it was imported to RISA 3D in order to conduct the structural analysis. The structural analysis in RISA 3D also consisted of developing loading combinations and calculating the tributary areas of the structure so that the loads could be imported into RISA 3D. In conjunction with this, we developed a prototype using wooden dowels and electrical connectors. This was completed at the end of A term. In B term, we began the model verification. This consisted of both hand calculations and the development of Microsoft Excel spreadsheets. The first Microsoft Excel spreadsheet was created to perform a buckling analysis for both steel and wood design. The next spreadsheet was used to calculate the joint, bolt, and plate sizing. Once these verifications were completed, we primarily worked on completing the final report.

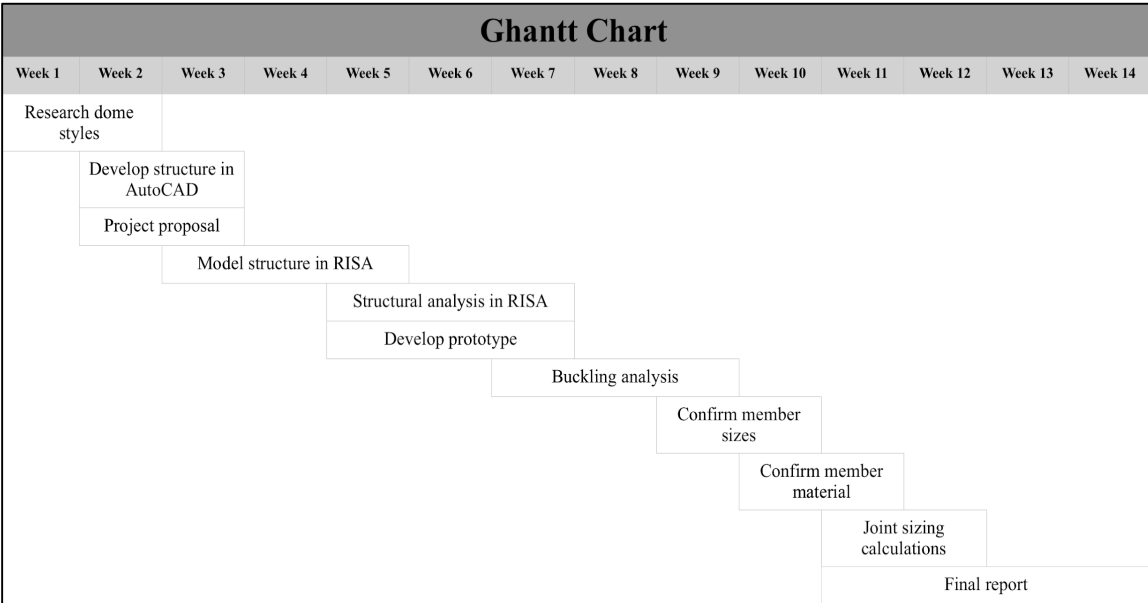

Figure 6: Gantt Chart

3.2 Design Iterations

The initial design for the dome, Design A, was a ribbed shaped structure that consisted of six curved members, as shown in Figure 7. Curved members cannot be analyzed in RISA 3D; therefore, each member was divided into 10 equal sections and these joints were then connected with linear members. Even with the linear members, this structure proved to be difficult to analyze in RISA 3D. Furthermore, the architectural vision for the structure shifted to having exposed triangular structural members. Therefore, the next iteration was a geodesic-dome inspired structure.

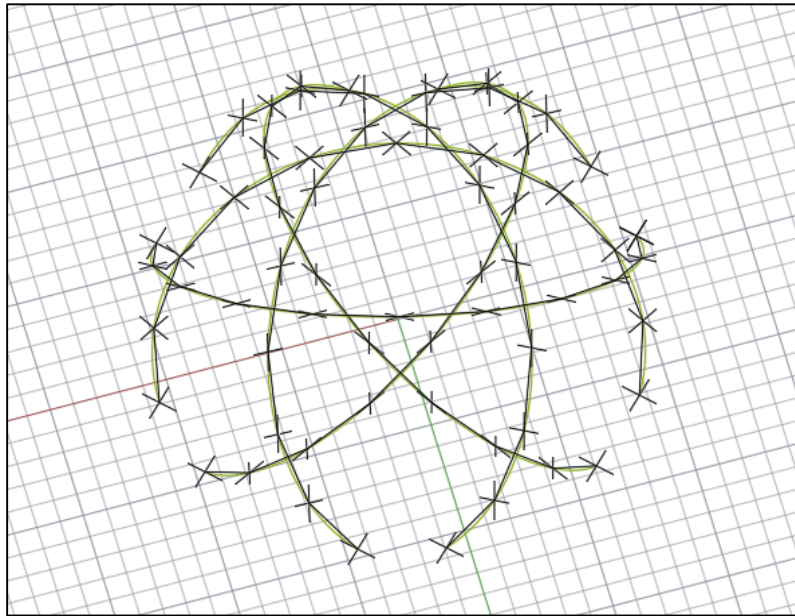

Figure 7: Design A

To create the next iteration of the structural model for the dome, Design B, we were provided with several specifications from the architectural team. The structure was to be a 12-sided shape that would follow the architect's scale by decreasing in increments of 1.2 meters in diameter and increasing in increments of 1.2 meters in height. The first step in creating the structure was to draw a dodecagon inscribed in a circle having a diameter of 9.6 meters, labeled as "base." The total structure consisted of 4 levels with a total height of 3.6 meters, as shown in Figure 6. Each of these levels were rotated 15 degrees with respect to the origin (0,0,0). Once all of the levels were created, each level was connected by a series of diagonals. Additionally, in order to maintain the structural stability of the dome, a triangle was added to the opening in the top level to support lateral loading. The profile, plan, and 3D views of this structure can be found in Figures 8-10.

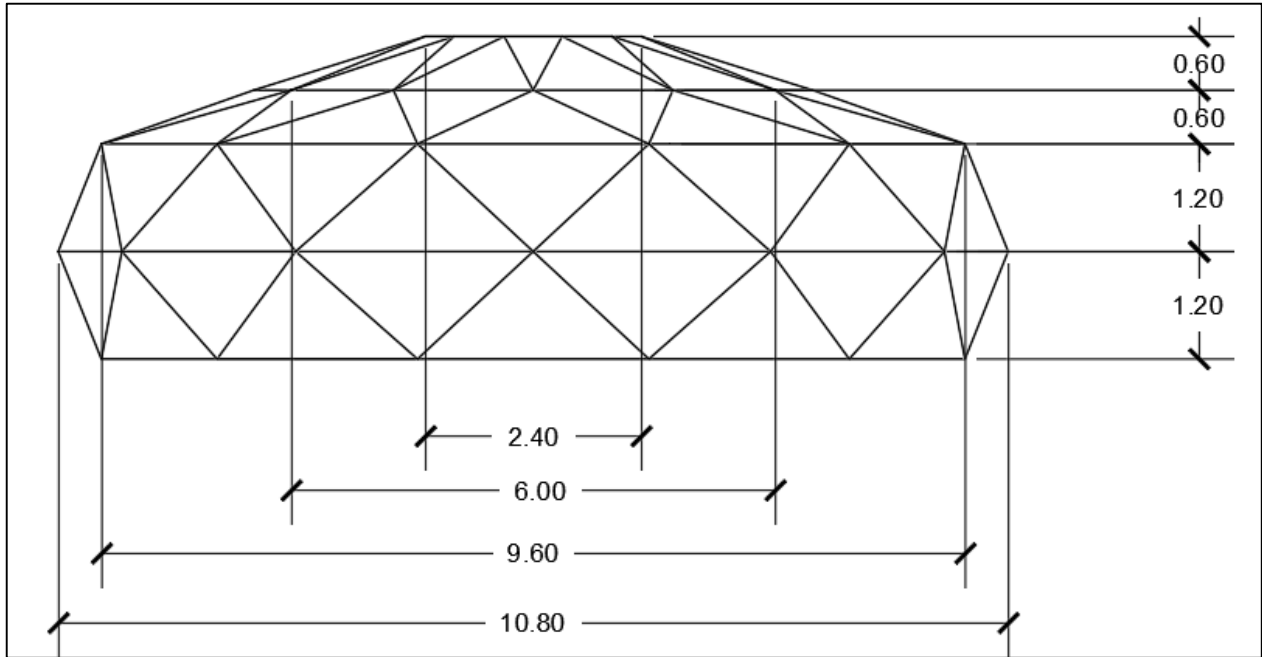

Figure 8: Design B, profile view, shown in meters

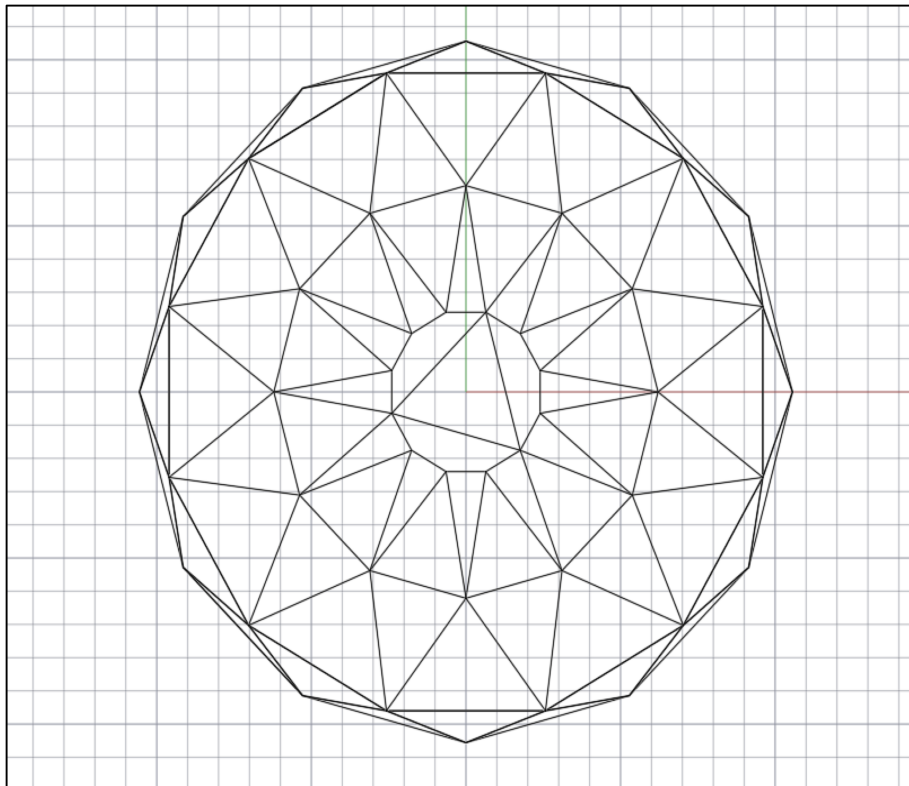

Figure 9: Design B, plan view

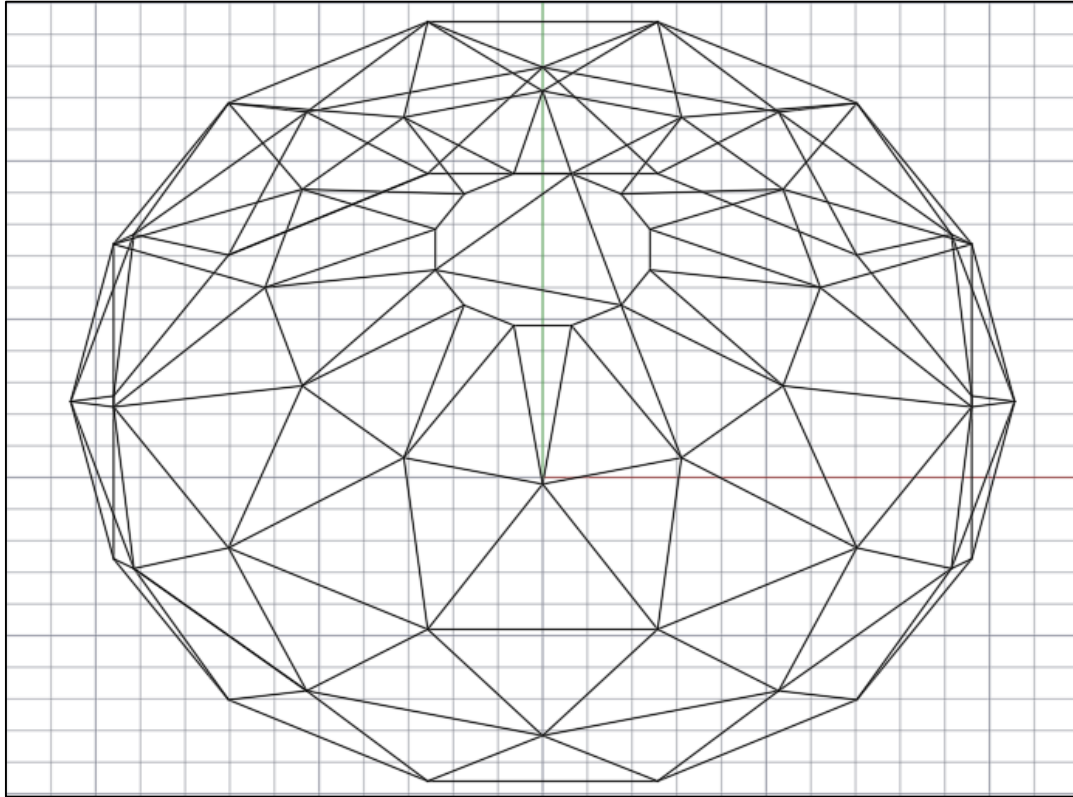

Figure 10: Design B, 3D view

In the final iteration of the dome, Design C, we removed the triangle from the top in order to create a completely open sky light. In order to maintain the structural stability, we added a compression ring. This compression ring consists of members that have no moment release, which means that they are capable of carrying moment. This creates stability for the structure because it inhibits lateral movement. Furthermore, in order to create a more curved look, the diameter of the first layer was increased to 11 meters and a fifth layer was added to the dome. Additionally, the scale was altered so that Level 3 was 0.58 meters above Level 2 with a diameter of 7.2 meters. Level 4 was inscribed inside a circle with a diameter of 4.8 meters and was placed 0.39 meters above Level 3. Finally, Level 5 was inscribed inside a circle of a diameter of 2.4 meters and was placed 0.23 meters above Level 4. Therefore, the total height of the structural system was still 3.6 meters. As in the previous iteration, each of these levels were rotated 15 degrees with respect to the origin (0,0,0). Once all of the levels were created, each level was connected by a series of diagonals. Additionally, the base members were removed from the structure because the load was carried directly from the structure to the pin supports on

either side of the base members, therefore, the base members themselves were not carrying any load.

Once this symmetric dome structure was created, two spaces were created to construct two doors. In order to do so, one of the members from Level 2 was removed and the two connecting Diagonal 1's were moved in order to create a base door opening of 1.2 meters. The same thing was done at a 120-degree angle to create the second door. Doors could be added in increments of 30 degrees to maintain the symmetry of the structure. An angle of 120 degrees was specifically chosen in order to accommodate the internal floor plan developed by the architectural team. The member properties for this structure can be found in Appendix A. Profile, plan, and 3D views of this structure can be found in Figures 11-13.

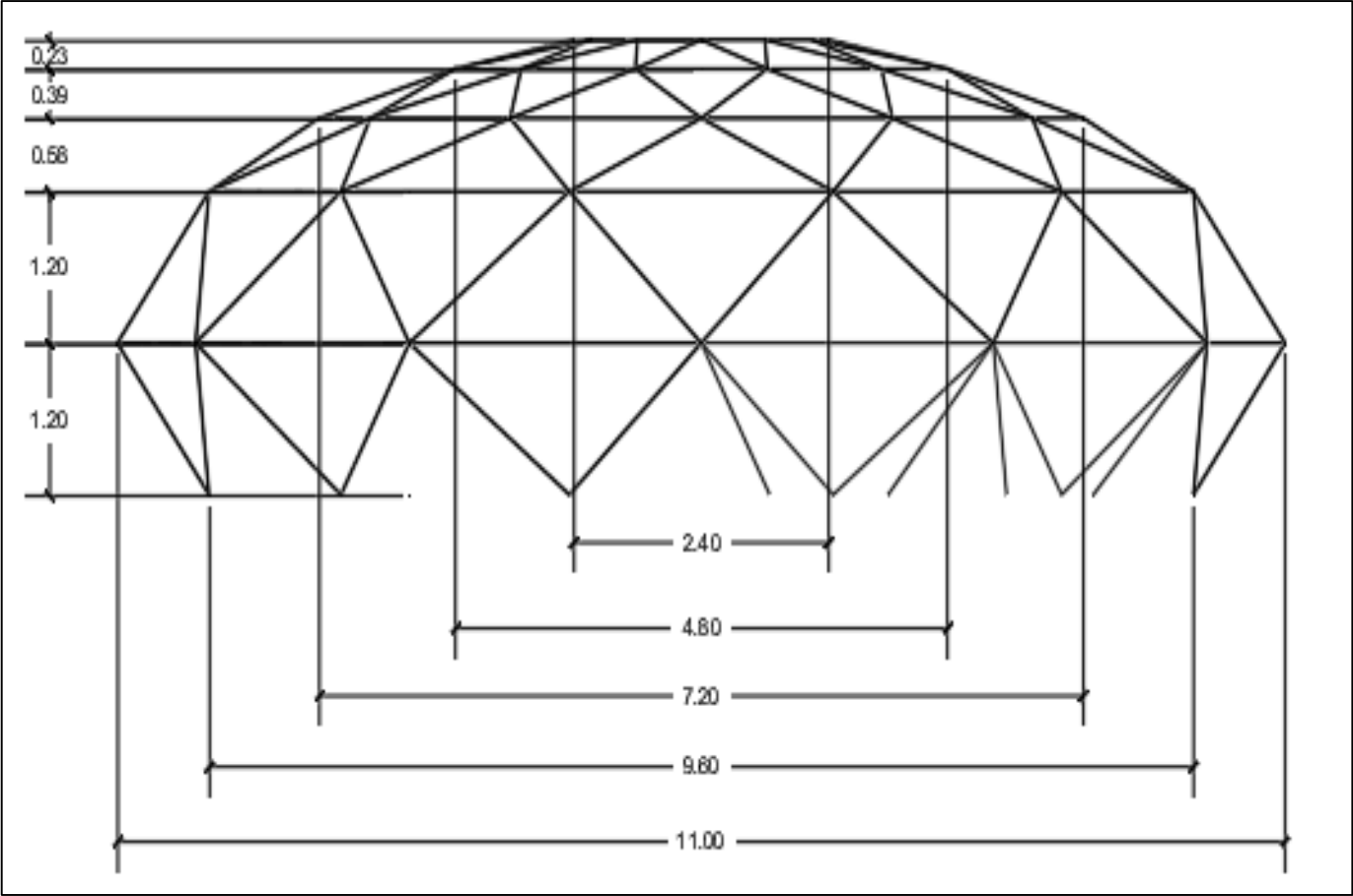

Figure 11: Design C, profile view, shown in meters

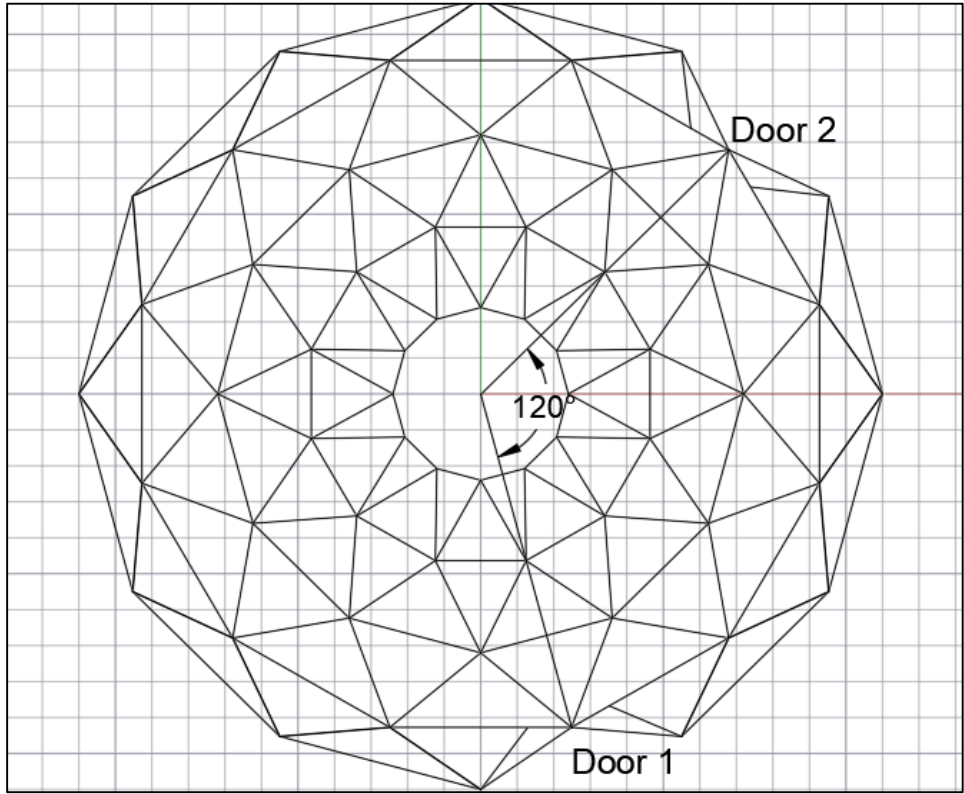

Figure 12: Design C, plan view

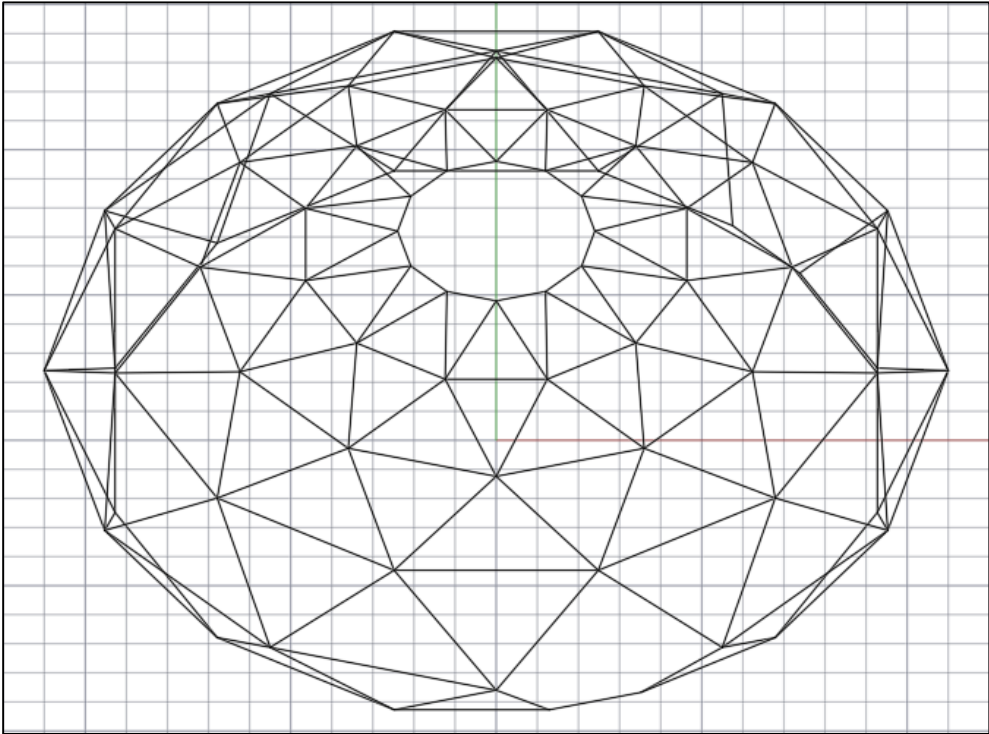

Figure 13: Design C, 3D view

3.3 Developing Loads and Loading Combinations

The loading that was applied to the structure was determined using ASCE 7-10. ASCE 7-10 provided a means for determining the load combinations for live load, dead load, snow load, earthquake load and wind load. According to ASCE 7-10 basic load combinations, the structure was designed so that their design strength equals or exceeds the following conditions:

Dead Load

The dead load of the structure was determined based on the weight of the architectural envelope used on the outside of the structure. The architectural team predicted the weight of the envelope to be 500 lbs. This includes the weight of the insulation and whicker. When this load is distributed over the entire structure, which has a total surface area of 1,657 square feet, the overall load is 0.3 psf. When this is converted to kN/mm^2 , it yields a dead load of $0.01kN/mm^2$. We designed our dome with hopes that our house could be implemented in various places across the world, in multiple different climates. With this in mind, we assumed the actual applied dead load of the envelope on the structure to be $0.1 kN/mm^2$. This creates more flexibility for different envelope designs and accounts for an increase in weight of the envelope if the house were to be built in a colder climate or with different materials.

Live Load

In order to determine the live load on the structure, it was important to consider the loads that would be applied to the structure over time. Considering that our design is a one story, geodesic-like dome structure, we assumed that it would behave similarly to a roof, because there would be no occupants or objects above creating a live load. With this in mind, we did want to account for the live load of people walking on the structure throughout construction and after construction for maintenance purposes. The estimated live load was determined to be $1 kN/mm^2$. This was taken from the International Building Code (IBC), Chapter 16 Live Loads (ICC, 2017). Due to the fact that the use of our structure is for Eco-Tourism, we originally classified the structure as a hotel and found the live load of a typical hotel unit to be 40 psf. This live load is much larger than the true live load of the structure, which would have led to oversized members, so we assumed the actual live load was half the value of the load given by the code. The load of 20 psf was then converted to kN/mm^2 , yielding an applied live load of $1 kN/mm^2$.

Wind Load

In order to determine the wind load applied to our structure, the Beaufort Wind Scale was consulted. According to the Beaufort Wind Scale, 55 to 63 mph is a wind speed that can cause considerable damage, so a wind speed of 63 mph was assumed. According to ASCE 7, to calculate the wind load on a given structure, multiply 0.00256 (a given constant) by the wind speed squared. In this case, the wind load on our given structure was around 10 psf, which is reasonable for a single-story structure. We then converted the wind load value to 0.5 kN/mm^2 in order to apply it to the structure. The wind load was then applied in the lateral direction as positive on one side of the structure and negative on the other side of the structure- as to mimic the push and pull that the wind load would have on the structure.

Earthquake load

The earthquake load was calculated using ASCE 7-05 Seismic Provisions. Base shear was calculated by multiplying the seismic response coefficient by the effective seismic weight (which includes the self-weight and snow loads on the structure). The seismic response coefficient is calculated by multiplying 1.2 by the effective peak acceleration coefficient of the earthquake by the site coefficient of the soil divided by the fundamental period to the 2/3rd power ($C_s = (1.2A_v S)/(T^{2/3})$). In order to obtain the effective peak acceleration value, we looked at a map that had average peak accelerations throughout Morocco and found the value that matched the geographic location of Ben Guerir (Badrane, Bahi, & Najine, 2007). The S value was assumed to be 1.0 due to the fact that when the site class is not known the authority having jurisdiction can assume that it is Site Class D. The fundamental period was determined by the following equation: $T_a = C_t H_n^x$. The value of C_t and "x" were determined by using ASCE 7-05 Seismic Provisions Values of Approximate Parameters which noted that steel moment resisting frames have a C_t value of .028 and "x" value of 0.8 (ASCE 7-10, 2010). This yielded a value of 2 kN for the earthquake load. The value for the earthquake load was then divided by the 14 nodes, and applied to each of those nodes. A summary of the calculations for the earthquake load can be found in Appendix B.

Snow Load

Although Morocco is not prone to snowfall throughout the year, there has been a handful of snow storms throughout Moroccan history, and we wanted to ensure that the design of our house remained conservative. In order to calculate the snow load applied to our structure, Chapter C7 Snow Load of ASCE 7 was referenced (ASCE 7-10, 2010). To determine the overall snow load of a structure, you must find the roof slope factor and multiply it by the given design load. In the case of our design, we assumed that our roof was sloped 0 to 30 degrees, meaning it had a roof slope factor of 1.0. ASCE 7 only has recorded design snow loads for regions within the U.S., so it was assumed that New Mexico would have a similar snow load to Morocco, due to their common arid continental climate. According to Figure 7-1 Ground Snow Loads, in ASCE 7, the snow design load in New Mexico was around 10 psf. This would yield an overall snow load of around $.5 \text{ kN/mm}^2$ or 10 psf (ASCE 7-10, 2010).

3.4 Calculating Tributary Area

In order to develop the loads to import into RISA 3D, the tributary area was calculated from the structure created in AutoCAD. The tributary area is the loaded area that contributes to the member carrying the load. In the case of the dome, the structure is a truss and therefore the loads are only applied at the joints. In order to determine the tributary area at each joint, the centroid of every triangle surrounded the joint. In order to do so, two different methods were used and the resulting areas were compared in order to ensure the correct values were being used.

The first method of calculating the tributary areas was using the following function combination in AutoCAD: REGION -> MASSPROP -> F2. This function displayed the centroid of each triangle. These points were then connected in order to display the loaded area that contributes to the central joint. If these areas were to be drawn around every joint, the entire surface area of the structure would be covered. The second method was to draw a line from the midpoint of every line segment composing the triangle to the opposite joint. In doing so for every side, the centroid was found to be the intersection point of all of these lines. A visual of developing the tributary areas using both of these methods is below in Figure 14.

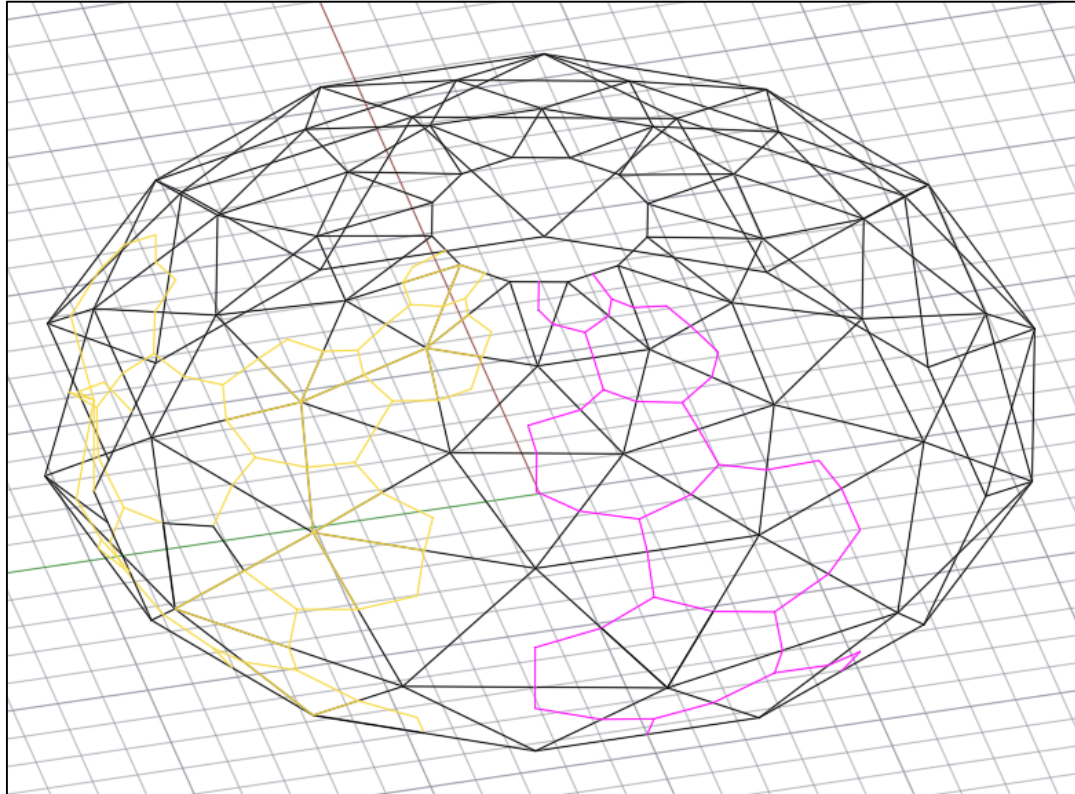

Figure 14: Tributary areas as drawn in AutoCAD

The Microsoft Excel spreadsheet found in Appendix C shows the tributary areas for each level of the structure. Based on ASCE 7-10, values were estimated for dead load, live load, snow load, earthquake load, and wind load. These loading values were then multiplied by the tributary area for each joint in order to find the corresponding load applied at that joint. These load values were then imported directly into RISA 3D. Additionally, factored loading combinations were defined in RISA 3D based on ASCE 7-10. These factored combinations can be found in Appendix D.

3.5 RISA 3D Modeling

To create our RISA 3D model, the previously drafted AutoCAD drawing was imported as a DXF file. The model was imported using metric units to align with the AutoCAD file. Once the import was complete, the program created a model with nodes and members similar to the one in AutoCAD.

For the program to properly determine the stability of the structure, supports had to be designated. Pin supports were added and assigned to all of the nodes in the base level of our

structure, since the supports must be fixed in their vertical and horizontal direction. Loads were assigned to the model and properties were added to the members such as material, size, and end release codes. Later we determined the basic load cases that would be applied on the structure, since the structure works as a truss system all of the loads needed to be applied at the joints. The joint column in the RISA 3d spreadsheet tab was then used to apply loads at each node based on our determined loads and the tributary area that the node would encompass. This same procedure was done for all the nodes and basic load cases. A list of the loads applied to each joint can be found in Appendix E.

When determining the member properties, we initially assigned arbitrary dimensions to our members so that the model could be solved to obtain a better understanding of the behavior of the structure. This was done by taking into account that our finalized members would be pipes for steel and rectangular members for wood. The section sizes would have to be revised as needed. Once the model was solved with these arbitrary properties, we were able to obtain the axial loads from our most severe loading combination, which we used as basis to create sections sets. The section sets were divided based on the severity of the internal load and member length. The number of section sets differed between steel and wood, since the axial loads differed based on the material weight. Shapes were later assigned using the “shape” column and the sizes were selected based on the material. Finally, the model was solved by using the solve tab and choosing single load combination, which determined whether the structure was stable with the assigned properties and provided us with results pertaining to shear, torque, axial forces, as well as moments within each member. The RISA 3D modeling process is further described in the flow chart shown in Figure 15.

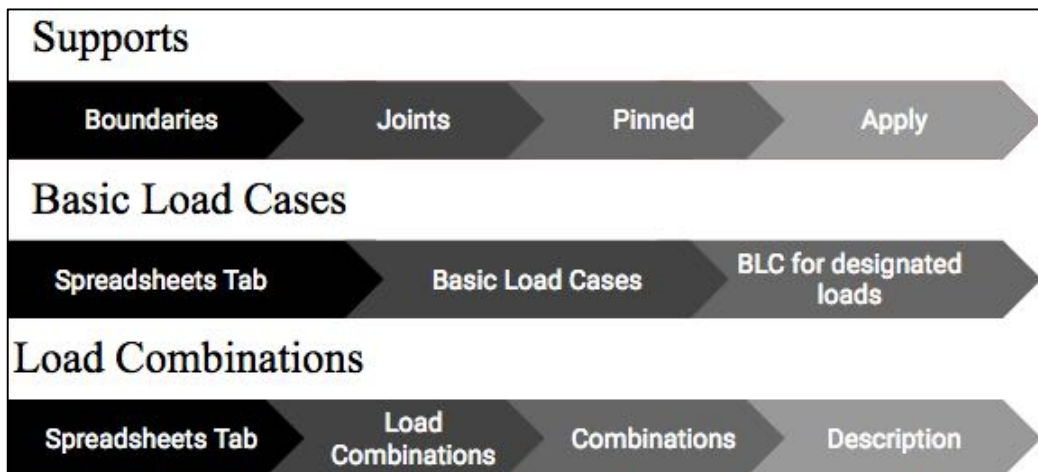

Figure 15: Flow chart for RISA 3D processes

3.6 Member Design and Analysis

To determine the necessary member sizes in RISA 3D, we used the member force outputs which provided us with the axial load per member. We decided that it would be best to use a custom designed steel pipe composed of A36 steel as the designated shape for steel and a rectangular cross section for wood. The density of A36 steel is $7,800 \text{ kg/m}^3$ and the density of Douglas Fir-larch is 500 kg/m^3 . Therefore, since the density of steel is much higher than that of Douglas Fir-larch, the required structural area of steel should be less than that of Douglas Fir-larch in order to withstand the same loading. Once the shape was determined we had to analyze the axial load outputs to have a better understanding of what cross sectional area and moment of inertia were necessary to account for these internal loads. In RISA 3D, we used the p delta command which notified us when there was a buckling issue in the members, and so we used a trial and error method to determine what sizes were feasible. To ensure a small weight in steel we compared the differences and benefits of having a large diameter with a small wall thickness to a small diameter with large wall thickness. Ultimately, we decided it would be best to have a small diameter with larger wall thickness since it would prevent local buckling of the members.

Once we determined what an acceptable size was on RISA 3D we transferred the dimensions of all members in both steel and wood to a Microsoft Excel sheet that we created to verify that the members were sufficient for the design. These Microsoft Excel sheets was coded so that it could provide us with an answer as to whether each member was failing or passing based on some set requirements such as load capacity, buckling (for those members in compression) and fracture (for those members in tension). For steel, we used Euler's critical stress equation and for wood we used the NDS standard and Ylinen column equation. Although we have determined specific shapes and sizes that should be used, it is important to note that if necessary other shapes and sizes can be used as long as they account for the necessary cross-sectional area, moment of inertia and pass both the buckling and fracture calculations. The RISA 3D and Microsoft Excel check served as proof that we had chosen sufficiently large member sizes to account for any foreseen issues while also taking into account buildability.

3.7 Member Buckling Check

As RISA 3D is a structural analysis software, it solves the model and outputs several different results, such as member displacements, and shear and moment capacity. One of the

results that RISA 3D does not solve for is a buckling check. Therefore, we developed a Microsoft Excel spreadsheet for both steel and wood to determine if the member would buckle in compression or fail in tension.

Wood Design

After the initial wood model was solved in RISA 3D, calculations were done in Microsoft Excel based on the National Design Specification (NDS) Design Values for Wood Construction. It was unclear whether RISA 3D determined the wood sizing and internal forces using the correct adjusted design values for a specified wood. Therefore, in order to check the buckling of each wood member, the allowable stress of the wood was compared to the actual internal force, which was generated and taken directly from RISA 3D. In order for the calculated wood sizing to resist buckling, the allowable stress of the wood must be larger than the internal force. The properties of Douglas Fir-Larch are found in Table 1. The process to determine the allowable stress of the wood members was taken from the Design of Wood Structures by Donald E. Bryer (Bryer, 2015). The first step was to find the actual size of the given wood member being solved for. Next, Table 4A from the NDS was referenced to find the design values in psi for bending, tension parallel to the grain, shear parallel to the grain, compression perpendicular to the grain, compression parallel to the grain and modulus of elasticity in Douglas Fir-Larch Grade No.2. A complete example of this process can be found in Appendix F.

Table 1: NDS properties for wood design

Constant	Value	Units
Bending	900	psi
Tension Parallel to Grain	575	psi
Shear Parallel to Grain	180	psi
Compression Perpendicular to Grain	625	psi
Compression Parallel to the Grain	1350	psi
Modulus of Elasticity	1600000	psi

Next, the capacity of the wood was found using Ylinen column equation $((K_e * l)/d)$. E' was then found by multiplying the given Modulus of Elasticity by $C_m, C_t, C_i, \text{ and } C_T$. This provided the adjusted modulus of elasticity used for this type of wood. The reason that adjustment factors are needed for wood design is because there is always some variation in the design values calculated for timber. F_{ce} was then calculated by multiplying K_{ce} by E' divided by the capacity of wood (which was found earlier) squared. F^*c was then calculated by taking the given compression parallel to the grain (in chart 4A from the NDS), multiplied by $C_d, C_m, C_t, C_F \text{ and } C_i$. The ratio of F_{ce} to F^*c was then calculated and used in the following equation:

$$C_p = \frac{1 + \frac{F_{ce}}{F_c^*}}{2c} - \text{sqrt} \left(\left(1 + \frac{F_{ce}}{F_c^*} \right)^2 - \frac{F_{ce}}{c} \right)$$

Figure 16: Equation for C_p adjustment factor

C_p was then used to solve for $F'c$ which is the adjusted compression parallel to the grain design value. The given value of F_c was multiplied by $C_d, C_m, C_t, C_f, C_p \text{ and } C_i$ to find $F'c$. Finally, $F'c$ was multiplied by the area of each wood member to find the allowable force of the member. This was then compared to the internal force of each member, which was taken from RISA 3D, to determine if the member could withstand the loads applied to the structure.

Steel Design

A buckling analysis was also conducted for A36 steel using the American Institute for Steel Construction (AISC) provisions for column design. Once the dimension of the pipe were chosen, the cross-sectional area and moment of inertia were calculated in order to be added to the buckling analysis spreadsheet. The cross-sectional area of a hollow pipe is the area of the inside circle subtracted from the area of the outside circle. The moment of inertia was calculated by using the equations shown in Figure 17.

$$\frac{\pi(D^4 - d^4)}{64}$$

Figure 17: Equation for moment of inertia for pipe

Next, several constants for A36 steel had to be found and converted in kN/mm². The constants used are listed in Table 2.

Table 2: AISC properties for steel design

Constant	Value	Units
Yield Strength	0.25	kN/mm ²
Ultimate Strength	0.4	kN/mm ²
Modulus of Elasticity	200	kN/mm ²

For members that were in compression, the following variables for the buckling check were calculated, as shown in Table 3.

Table 3: Equations for steel buckling check

Variable	Equation	Units
Radius of Gyration, r	$\sqrt{I/A}$	mm
Critical Length	l/r	-
Euler's Critical Stress, σ_y	$\pi^2 E (l/r)^2$	kN/mm ²
Calculated Critical Stress, σ_y	if $l/r < 4.71 \sqrt{E/\sigma_y} \rightarrow (0.658^{\sigma_y/\sigma_e}) \sigma_y$ if $l/r > 4.71 \sqrt{E/\sigma_y} \rightarrow 0.877e$	kN/mm ²
Critical Stress*Factor of Safety, σ_{cr}	$0.9 * \sigma_{cr}$	kN/mm ²
Actual Axial Stress, σ_y	F/A	kN/mm ²

If the actual axial stress is less than the critical stress*factor of safety, then the member does not buckle. However, if it is greater, then the member buckled. For members that were in tension, a tension check and fracture check were developed, using the equations shown in Table 4. If the internal force in the member was less than the calculated value for tension and fracture, then the member passed.

Table 4: Tension and fracture check for steel

Tension Check	$.9A\sigma_y$
Fracture Check	$.75A\sigma_u$

3.8 Joint Design

When creating the joint design for the structure, we considered the ease of construction, weight of the joint, material for the connection, and the bolt sizing. Our connection consists of one or two steel plates connecting the wooden member to a circular plate. These plates would be connected from wood to steel and steel to steel with bolts. To find the necessary bolt sizes we created a Microsoft Excel spreadsheet which determined the shear strength of the designated bolts. The steel plate width was designated as 3.5 inches since this is the size of the wooden member and the thickness of the steel was assumed $\frac{1}{4}$ inches since this would be the most feasible for construction. We began by using three different grades of steel which were: A307, A325 and A490. This was done to compare the shear strength capacities of the different grades. Initially we used $\frac{1}{2}$ inch (12.7 mm), $\frac{5}{8}$ inch (15.9 mm) and 1 inch (25.4 mm) diameter bolts since these are standard bolt sizes. For the steel to steel connection the minimum edge distance was assumed to be 2.5D and the distance between the bolts was assumed 3D, where D is the diameter of the bolt. This connection was analyzed for bearing, yielding of the plate, tensile rupture and shear strength.

In order to determine the reference design value for single-shear bolt in wood-to-metal connection we used the Design of Wood Structures-ASD/LRFD (Breyer, 2015). The first step to calculating the design value was to determine the known values necessary to evaluate the yield limit equations. The member thickness in this case was 3.5 inches, which is the nominal value for a 4x4 inch members. The angle of design was assumed to be 90 degrees. The dowel bearing strengths in psi was determined using the Dowel Bearing Strengths Table in NDS. Douglas Fir-larch has a specific gravity of 0.50 G, which yields a F_{em} value of 4,650 psi and F_{es} value of 5,600 psi (NDS, 2005). The second step in determining the coefficients for yield limit equations was to determine the values of k_1 , k_2 and k_3 . These values were then used in the Yield Limit Equations, in order to determine the "Z" value for each design mode. The reference design value was then selected as the smallest reference design value, "Z". This value was then compared with

the value from the NDS Table Bolts: Reference Lateral Design Values (Z) for Single Shear (two member) Connections, to see if the values were equivalent. If the calculated value was similar or equal to the one in the table, the design value was allowed (Breyer, 2007).

To determine the necessary parameters for the bolts to be spaced we used the NDS for the wood 4x4 inch member. For a steel to wood connection, which in this case would be the A36 steel plate being connected to the 4x4 inch member, there must be an edge distance of $1.5D$, end distance of $3.5D$, distance between bolts of $3D$ and a distance between rows of $1.5D$ where D is the diameter of the bolt. When conducting a double shear analysis, there are different modes of failure. Mode III is the most common for double shear and is shown in Figure 18.

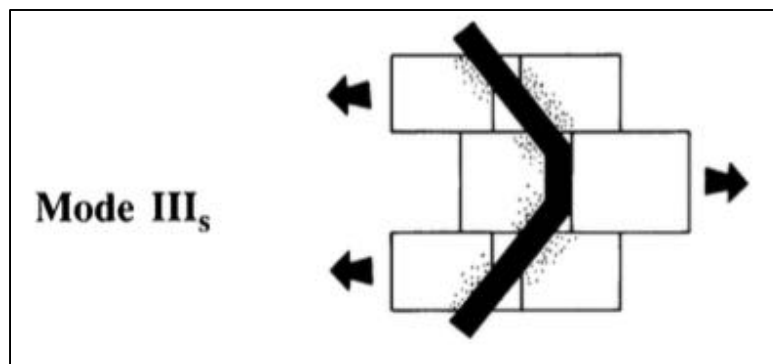

Figure 18: Double shear failure mode

3.9 Creating a dome prototype

It is very important to transfer the theoretical design into a working device to understand how the structure functions. Another way to verify the RISA 3D model was by building a 1/20 scale model of the dome. In order to do so, we used 8 inch wooden skewers as the members and 16-14-gauge crimp terminal connectors for the joints. First, we cut all of the wooden skewers two centimeters larger than the desired size to take into account for the portion of the skewer that is covered by the connector. Next, we hot glued the wooden skewers into the connectors to replicate a fixed connection. We then created each dodecagon level and connected the levels with the diagonal members. The base joints have four members coming out of them and all other members have six joints coming out of them. After all of the members were connected, they were bolted using a washer to replicate a fixed joint. The dome prototype is shown in Figure 19.

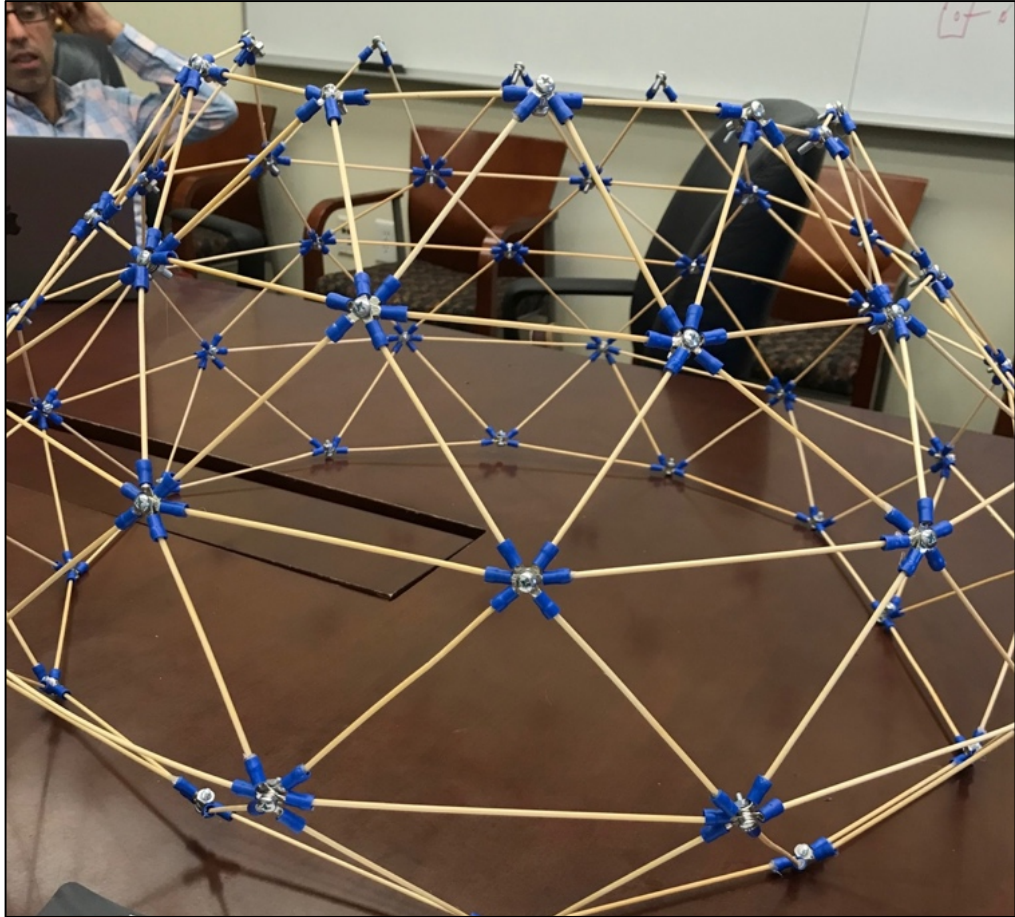

Figure 19: Dome prototype (Sheehan, 2018)

Chapter 4: Results and Discussion

4.1 Wood Structure Design

The RISA 3D model was solved for three different wood models. There was one model for a 2x section, 3x section and 4x section. The model provided us with results pertaining to joint reactions, deflections, and member forces, among others. These results gave us information about the stability of the model and its behavior. As a result of the two doors being added to the structure 120 degrees apart from each other, the forces in the structure were not symmetrical. As a result of the pinned connections and geometry of the structure, there was minimum deflection. The summary of the deflections are shown in Table 5.

The compressive forces exist in the first and second level horizontal and diagonal members of the structure as well as in a single member in the third level. These members are in compression because of the small angle in between these two levels. The members around the doors are in compression because the change in the geometry caused the lower diagonals to carry more load as they no longer had the tensile reaction for the horizontal member that was removed. This singular member in the third level is in compression because of the redistribution of loads. The shear, torque and moment forces in the members were either zero or miniscule, which means there will be no rotation of the members or moment being carried throughout the structure other than in the top ring which serves as a fixed member. The summary of all of these forces can be found in Table 5.

We were then able to determine the percent failure of each member, by comparing the allowable and actual internal forces. In order to maximize the strength of design and decrease the size of materials, we tested three different models which each had varying member sizes. The first model tested was a structure constructed from 2x12 and 2x10 inch members. In this model, 20 out of 178 members failed, and 8 out of the 20 members failed by a magnitude of over 100 percent. The second model tested was a structure constructed from 3x8 and 3x6 inch members. Three out of the 178 members failed, and all three failed by less than 15 percent. The third model tested was a structure designed from 4x4 inch members. The results calculated for each member can be found in the deliverables provided separately from this report. Overall, after looking at the spreadsheets, located in the Deliverables, the most cost efficient and effective wood design would be using the 4x4 inch structure.

4.2 Steel Structure Design

Once the RISA 3D model was solved for steel, it provided us with results pertaining to joint reactions deflections and member forces, among others. As with the wood, there was minimum deflection. The member force tab in RISA 3D presented us with the most information regarding axial, shear, torque and moments within each member. A summary of these forces is found in Table 5.

Using the process described in the methodology, the critical stress, σ_{cr} , in each member was calculated. This was then compared to the actual axial stress, σ_y , which is a function of the internal force calculated in RISA 3D divided by the cross-sectional area of that member. If the actual stress was less than the critical stress, then the member did not buckle. Once the smallest members that were stable in RISA 3D were determined, those values were entered into the Microsoft Excel sheet to ensure that they did not buckle. The smallest steel member size that did not buckle and passed in RISA 3D was a 62.54 mm diameter HSS pipe with a wall thickness of 6.364mm.

Table 5: Result for steel and wood designs

Member Material	Max x Deflection (mm)	Max y Deflection (mm)	Max z Deflection (mm)	Max Compressive Force (kN)	Max Tensile Force (kN)	Max y Shear (kN)	Max z Shear (kN)	Max Torque (kN-m)	Max Z Moment (kN-m)
2x12 2x10 Douglas Fir-Larch	5.25	8.32	4.84	60.05	-58.27	0.15	0.08	0.05	0.10
3x8 3x6 Douglas Fir-Larch	4.92	7.76	4.52	60.13	-58.29	0.14	0.08	0.05	0.10
4x4 Douglas Fir-Larch	7.04	10.82	6.51	59.2	-57.62	0.13	0.08	0.05	0.09
A36 Steel	3.87	6.24	3.58	64.12	-62.41	0.16	0.16	0.08	0.11

For both steel and wood, a summary of the member length for every level and diagonal and the range of internal forces can be found in Figure 20.

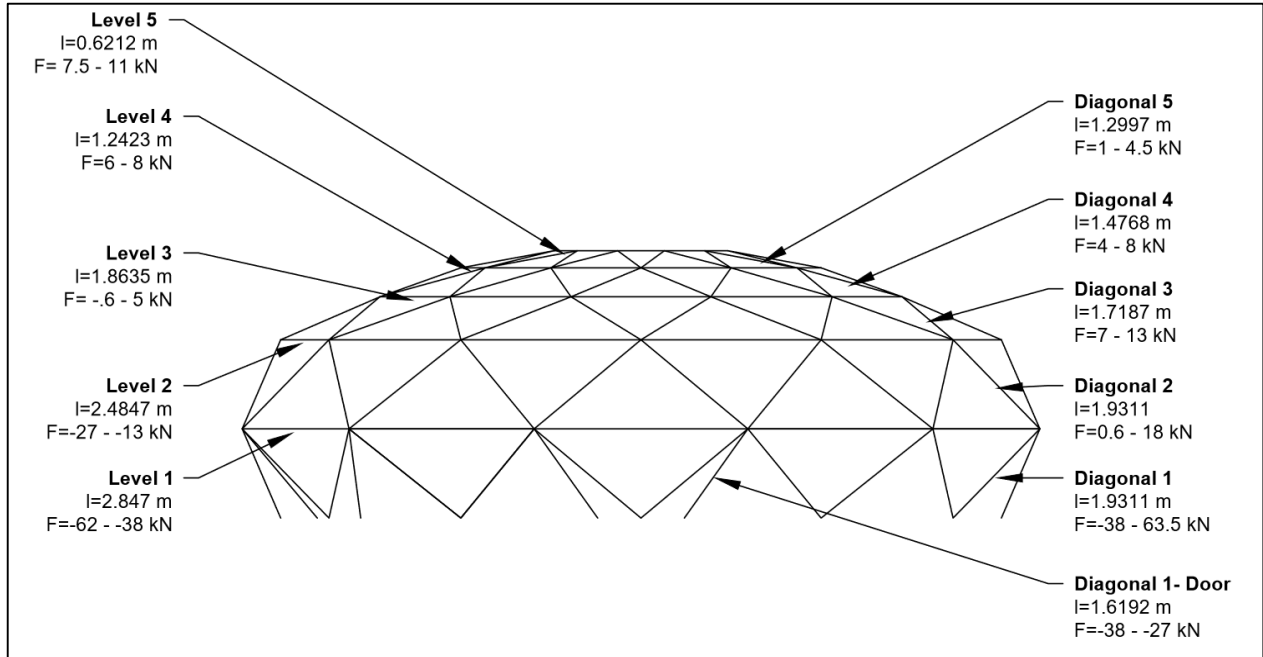

Figure 20: Member lengths and range of axial loads

4.3 RISA 3D Modeling

Once all of the loading combinations and member properties were applied in RISA 3D, the model was solved. By solving the model, RISA 3D displays several different graphs that we used to understand how the structure was behaving under the applied conditions. Figure 21-24 show the structure behavior for all of the wood designs and steel design. Additionally, Figure 25 show a plan view of the structure with every member labeled. This figure can be compared to the spreadsheet attached as a deliverable which includes the results for every member.

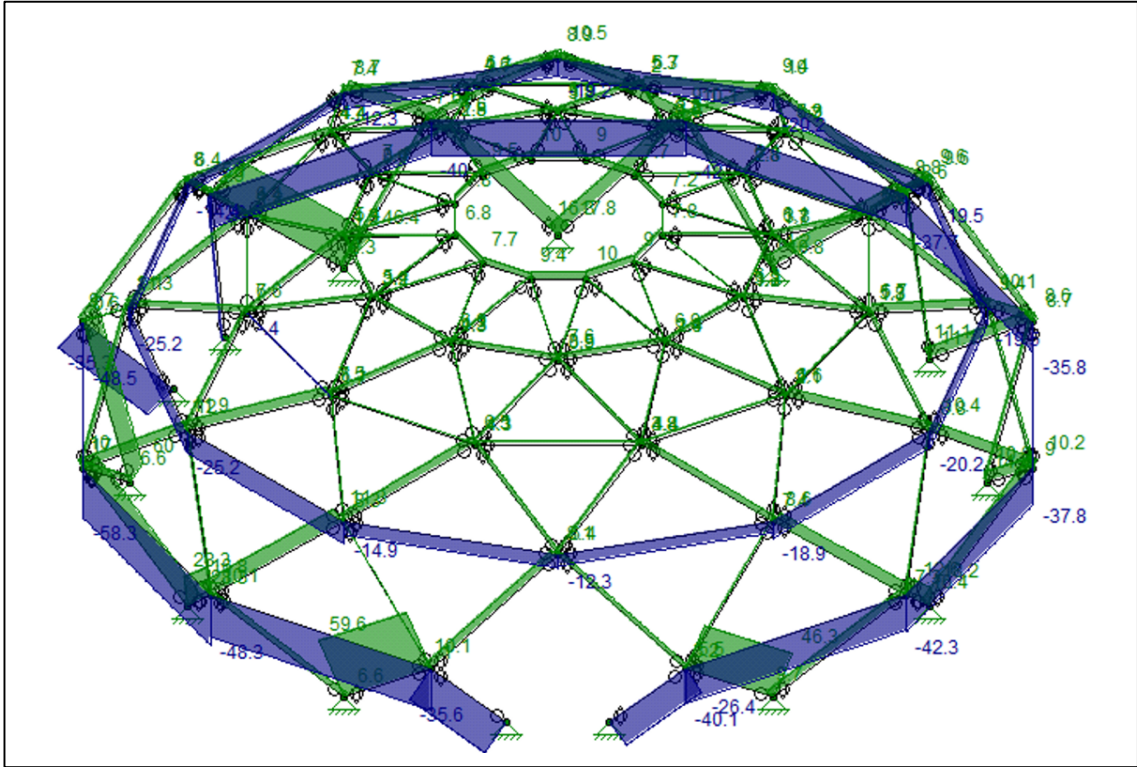

Figure 21: Axial forces in 2x12 and 2x10 wood design

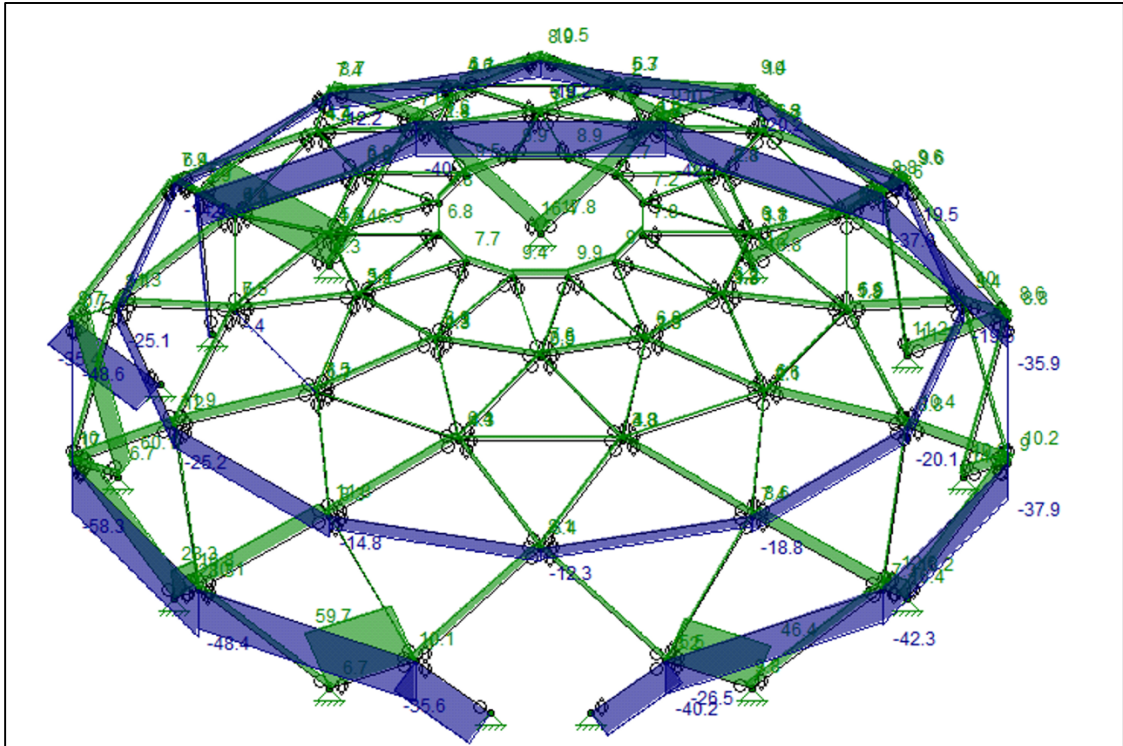

Figure 22: Axial forces in 3x8 and 3x6 wood design

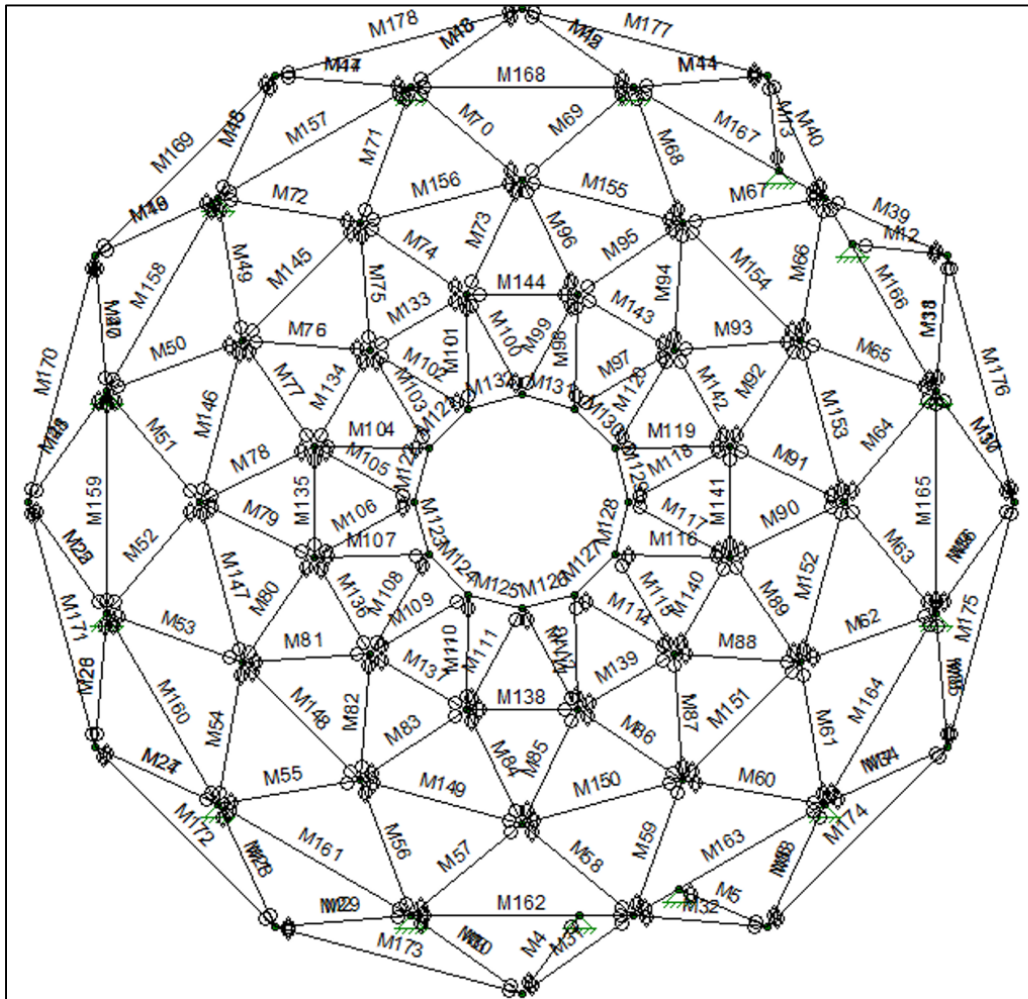

Figure 25: Member labels

4.4 Comparison with Moroccan Team

Throughout the project, we have been collaborating with our Moroccan counterparts in order to check the accuracy and success of our results. We began this process by sending our AutoCAD file of the design for them to run with their own modeling software. They used Robot, a structural analysis software to determine internal loads, member lengths, and other results. One important factor to note is that the WPI group used the ASCE 7-10 to determine the loading and load combinations, and our Moroccan counterparts used the Moroccan Code. Overall, when comparing loads, the Moroccan team's applied loads were around half the value of our calculated applied loads. The loads were then applied using RISA 3D and Robot. After both the wood 4x4 inch and A36 steel models were analyzed using the modeling software, the results from each team were compared, as shown in Table 6.

Table 6: Result comparison with Moroccan team

	Wood 4x4			A36 Steel 63.53mm diameter, 6.363mm wall thickness		
Section	WPI Peak Loads (kN)	ENSAM Peak Load (kN)	Percent Difference (%)	WPI Peak Loads (kN)	ENSAM Peak Load (kN)	Percent Difference (%)
Diagonal 1 - Tension	-35.12	-38.55	9.31	-38.08	-29.09	26.77
Diagonal 1 - Compression	58.77	30.49	63.37	64.12	48.33	28.08
Diagonal 2	16.83	11.04	41.54	18.26	13.77	28.05
Diagonal 3	11.86	8.18	36.71	12.96	10.19	23.96
Diagonal 4	7.47	5.38	32.46	8.23	6.61	21.78
Diagonal 5	4.22	3.01	33.47	4.66	3.23	36.29
Level 5	9.82	0.00	200.00	10.89	0.00	200.00
Level 4	7.56	4.32	54.59	8.27	7.79	5.99
Level 3	4.41	2.44	57.60	4.52	5.69	22.94
Level 2	-24.99	-17.1	37.50	-27.29	-20.68	27.54
Level 1	-57.61	-38.31	40.25	-62.41	-48.04	26.03

4.5 Bolt Design

The shear calculations for bolts in the joint design were done using 1, 2 and 3 bolts to ensure there were several options when construction takes place. We determined it would be best to use 2 bolts since it serves as a precaution because it is safer to have more bolts in order to ensure redundancy. After calculating the allowable shear strength of the bolt this was compared to the internal force to ensure the bolt was capable of withstanding said load. When looking at the Microsoft Excel sheet all of the bolts passed except for the A307 grade ½ inch (12.7 mm) and ⅝ inch (15.89 mm) diameter bolts. Since the highest axial force for the 4x wood members was 59.2 kN we determined it was best to use A325 grade bolts since this has a nominal shear

strength of 0.37 kN/mm^2 compared to A307 which is approximately 0.19 kN/mm^2 . We also found that the $\frac{5}{8}$ inch (15.89 mm) diameter bolt would work the best since it has a capacity of 110.54 kN when using two bolts. When comparing the applied load to the shear strength of two A325 $\frac{5}{8}$ inch bolts the applied load was nearly half of the shear strength, for which reason we know that this size and grade was acceptable. The results for the bolt design are shown in Table 7.

Table 7: Results for Bolt Design

Bolt Grade	1 Bolt Shear Strength (kN)	2 Bolts Shear Strength	3 Bolts Shear Strength	Bolt Diameter (in)	Min Edge Distance (in)	Distance Between Bolts (in)
A325	55.29	110.54	165.81	5/8	1.56	1.88

4.6 Shear Analysis for Steel Joint and Steel Members

The shear analysis for the steel plate and steel joint connection was done to ensure the loads were being transferred correctly between the bolt, plate and joint as well as to ensure these were able to withstand the internal loads. The calculations were done on Microsoft Excel with three different grades and diameters as was done for the bolt design. Since we determined A325 grade steel of $\frac{5}{8}$ inch (15.89 mm) diameter would be the best option we focused on the outcome for this bolt. The bearing strength, tensile rupture and allowable shear strength values can all be seen in Table 8: Results for Steel members, which were compared to the maximum internal load of 59.2 kN. When the values were compared it was clear that the steel joint and steel plate were capable of transferring the load and withstanding any shear.

Table 8: Results for steel joints and steel members

Bolt Grade	Plate Thickness (mm)	Plate Length (mm)	Yielding of Plate (kN)	Bolt Bearing 2 Bolts (kN)	Tensile 2 Bolts Rupture	Allowable Shear Strength (kN)	Max Number of Bolts
A325	6.35	88.9	225.75	127.0	108.37	844.89	2

4.7 Shear Analysis for Steel Joint and Wood Members

The double shear analysis was done for a bolt in a wood to steel connection to ensure that the wood would not fail in shear. The steel was assumed to be A36 steel and the wood was a 4x4 inch member of Douglas-Fir Larch. A similar process to the wood-to-wood check was done, and the smallest design value was found. The smallest design value was determined to be 2,625 lbs, which was then compared to a table in the NDS which has design values for Douglas-Fir Larch. The design value was 2,410 lbs, which means that the smallest calculated design value was within reason. The limiting failure was determined to be Mode IIIs. A summary of these results and the number of bolts required is found in Table 9. Additionally, the joint design for a steel joint and wooden members is shown in Figure 26.

Table 9: Results for steel joint and wood members

Bolt Grade	Plate Thickness (in)	Plate Length (in)	Bolt Size (in)	Smallest Design Value (lbs)	Allowable Force (lbs)	Max Number of Bolts
A325	0.25	3.5	5/8	2,625	2,410	5

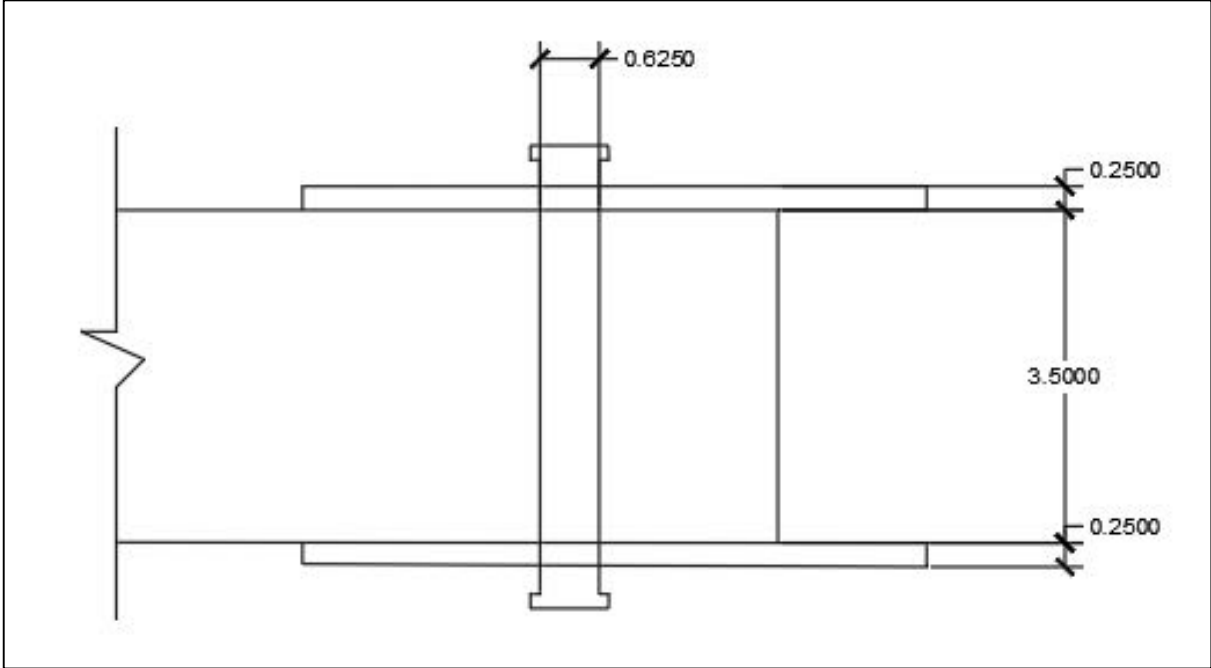

Figure 26: connection design, shown in inches

4.8 Shear Analysis for Wood Joint and Wood Members

Although a wood joint is not typical, we still conducted the analysis in order to determine what the capacity of wood would be as it would likely fail due to crushing. We used the same bolt size of 5/8 inch. In order to calculate the number of bolts needed, the maximum axial force was divided by the calculated design value. Therefore, the number of bolts needed was found to be 20. This would not meet the spacing requirements needed and therefore this design was not chosen. The summary of these results is found in Table 10.

Table 10: Results for wood joint and wood members

Bolt Grade	Plate Thickness (in)	Plate Length (in)	Bolt Size (in)	Smallest Design Value (lbs)	Allowable Force (lbs)	Max Number of Bolts
A325	0.25	3.5	5/8	286.18	610	20

Chapter 5: Recommendations and Conclusion

Based on the RISA 3D modeling and Microsoft Excel spreadsheet calculations, we were able to find two final designs that were structurally stable, meaning that no members were in failure. We originally modeled the design in both wood and steel in hopes of finding a model that was structurally stable, had ideal member sizing and was made from sustainable material. Table 11 displays the final steel design of the model, which includes the diameter, wall thickness, maximum internal force, maximum axial stress and maximum critical stress. Table 12 includes the final wood designs and the maximum internal force, allowable internal force, and number of members in failure for each of the design options. Table 13 displays the max internal force, max allowable internal force and number of members in failure for each section set. After considering each material and design parameters, we settled on the 4x4 inch wood design model. Wood is a more sustainable material, lightweight and is easier to prefabricate into unique members.

Table 11: Steel results

Material	Diameter (mm)	Wall Thickness (mm)	Max Internal Force (kN)	Max Axial Stress (kN/mm²)	Max Critical Stress (kN/mm²)	Number of Members in Failure
A36 Steel	63.54	6.364	63.552	0.106	0.215	0

Table 12: Wood results

Material	Section Set 1	Section Set 2	Max Internal Force (lbs)	Max Allowable Internal Force (lbs)	Number of Members in Failure
Douglas Fir-Larch	2x12	2x10	13,397.63	31,316.33	20
Douglas Fir-Larch	3x8	3x6	13,416.12	86,206.11	3
Douglas Fir-Larch	4x4	4x4	13,196.88	150,531.54	0

Based on the connection design results for steel to steel, steel to wood, and wood to wood, we recommend using a steel to wood connection with five bolts and a steel to steel connection with two bolts. For the steel to wood this would include an edge distance of 1.17, end distance of 2.1875, spacing between bolts of 1.875 and spacing between rows of 1.17 inches. For the steel to steel this would consist of an edge distance of 1.75, end distance of 1.5625 and a distance between bolts of 1.875 inches these layouts are shown in Figure 27 and Figure 28.

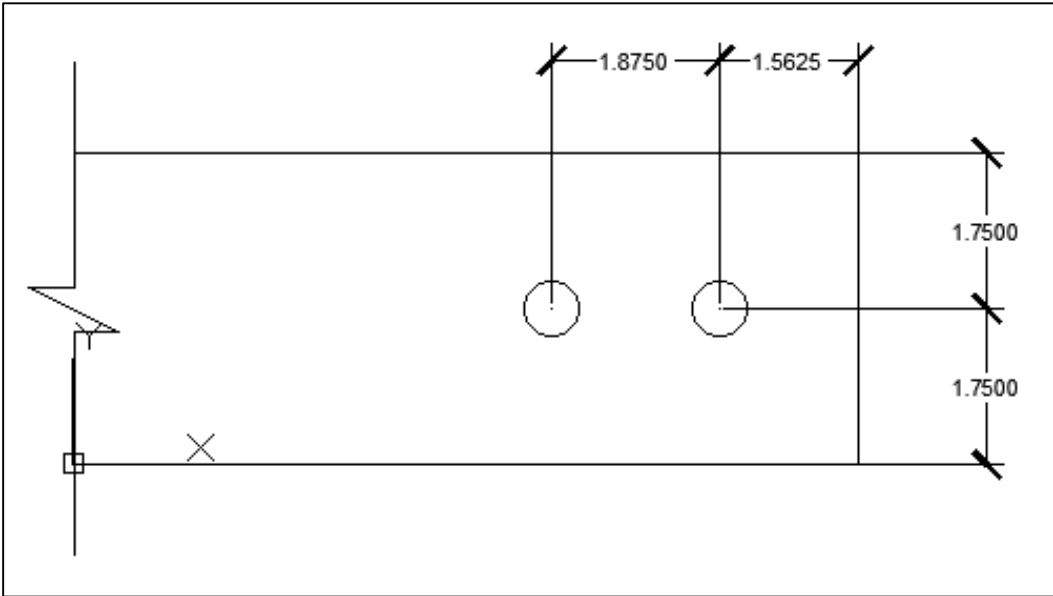

Figure 27: Steel to steel connection bolt layout, shown in inches

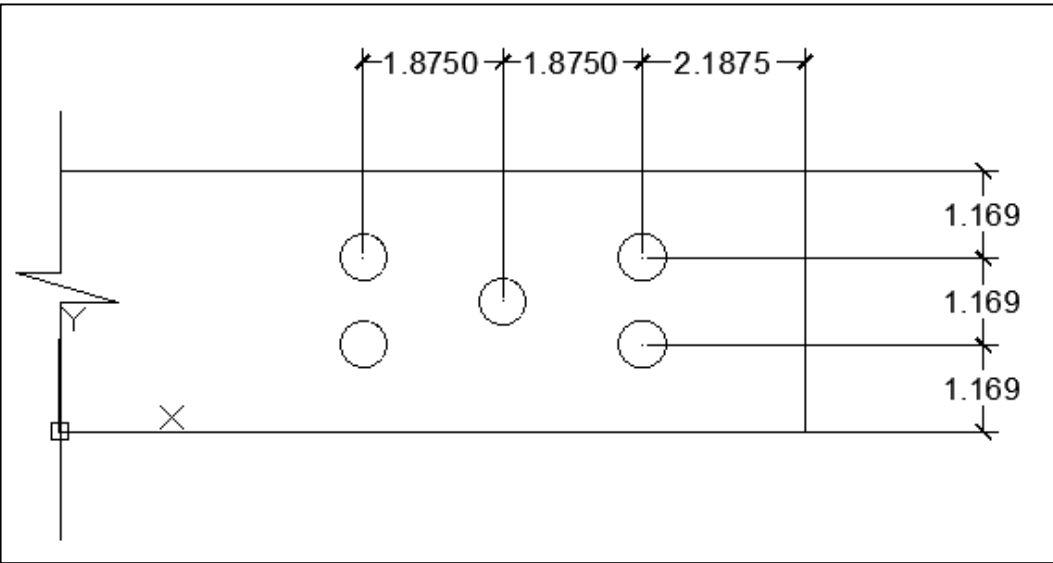

Figure 28: Steel to wood connection bolt layout, shown in inches

Table 13: Design criteria for Professional Engineer to review

Member	Number of Members	Length (m)	Max Internal Force (kN)	Steel Moment of Inertia (mm³)	Wood Moment of Inertia (mm³)
Diagonal 1	20	1.9311	64.115	2.76E+05	1.25E+01
Diagonal 1-Door	4	1.6129	-38.075	2.76E+05	1.25E+01
Diagonal 2	24	1.9311	18.263	2.76E+05	1.25E+01
Diagonal 3	24	1.7187	12.881	2.76E+05	1.25E+01
Diagonal 4	24	1.4768	6.607	2.76E+05	1.25E+01
Diagonal 5	24	1.2997	4.647	2.76E+05	1.25E+01
Level 5	12	0.6212	10.9	2.76E+05	1.25E+01
Level 4	12	1.2423	8.271	2.76E+05	1.25E+01
Level 3	12	1.8635	4.591	2.76E+05	1.25E+01
Level 2	12	2.4847	-21.963	2.76E+05	1.25E+01
Level 1	12	2.847	-62.414	2.76E+05	1.25E+01

References

- About Solar Decathlon. (2018). Retrieved from <https://www.solardecathlon.gov/about.html>
- Badrane, S., Bahi, L., & Najine, A. (2007). Evaluation De L'Alea Sismique Dans Le Nord Du Maroc Par L'Utilisation Du Code Crisis99. *Geomaghreb*, 65-72. Retrieved November 21, 2018, from [http://www.geo-maghreb.com/journal/volumes/Geomaghreb4/Said BADRANE et al..pdf](http://www.geo-maghreb.com/journal/volumes/Geomaghreb4/Said%20BADRANE%20et%20al..pdf)
- Breyer, D. E. (2015). *Design of wood structures--ASD/LRFD*. New York: McGraw-Hill Education.
- Donald E. Breyer; Kenneth J. Fridle; Kelly E. Cobeen; David G. Pollock: Design of Wood Structures-ASD/LRFD, Sixth Edition. Bolts, Lag Bolts, and Other Connectors, Chapter (McGraw-Hill Professional, 2007 2003 1998 1993 1988 1980), AccessEngineering
- Cherkaoui, T., & EL HASSANI, A. (2012). Seismicity and Seismic Hazard in Morocco 1901-2010. Retrieved December 2, 2018, from [http://www.israbat.ac.ma/wp-content/uploads/2015/01/05-Cherkaoui BIS_ST34_45.pdf](http://www.israbat.ac.ma/wp-content/uploads/2015/01/05-Cherkaoui_BIS_ST34_45.pdf)
- Douglas Fir-Larch. (n.d.). Retrieved December 2, 2018, from <https://www.uslumber.com/MainSite/Store1/Store/CategoryHome/1684>
- ICC. (2017, August). 2018 International Building Code. Retrieved from https://codes.iccsafe.org/content/IBC2018?site_type=public
- Peng, Z. (2016, October). Geodesic Dome Structural Analysis and Design. Retrieved 2018, from [https://eprints.usq.edu.au/31457/1/Peng_Z Sourish.pdf](https://eprints.usq.edu.au/31457/1/Peng_Z_Sourish.pdf)
- Load & resistance factor design. - 1: Structural members, specifications & codes: Manual of steel construction.* (1994). Chicago, IL: American Institute of Steel Construction.
- McCormac, J. C., & Csernak, S. F. (2012). *Structural steel design*. Boston: Prentice Hall.
- Minimum design loads for buildings and other structures.* (2010). Reston, VA: ASCE.
- NDS, national design specification for wood construction ASD/LRFD.* (2005). Washington, D.C.: American Forest & Paper Association.
- N. (n.d.). Beaufort Wind Scale. Retrieved November 21, 2018, from http://gyre.umeoce.maine.edu/data/gomoos/buoy/php/variable_description.php?variable=wind_2_speed
- Roudies, N. (2013). Vision 2020 for tourism in Morocco. *Focus on Sustainability and Ecotourism*. Retrieved December 3, 2018, from <https://sustainabledevelopment.un.org/content/documents/4104roudies.pdf>.
- Wai-Fah, C. (1999). Space Frame Structures. Retrieved 2018, from <https://pdfs.semanticscholar.org/c81d/e2134b42f4cee2c66a3c2e5961607b0222ac.pdf>

Appendix A: Member Properties

Section Set	Member	I joint	J joint	Length (m)
Diagonal 1	M1	N64	N52	1.9311
Diagonal 1	M2	N52	N68	1.9311
Diagonal 1	M3	N68	N53	1.9311
Diagonal 1	M4	N53	N69	1.6129
Diagonal 1	M5	N70	N54	1.6129
Diagonal 1	M6	N54	N67	1.9311
Diagonal 1	M7	N67	N55	1.9311
Diagonal 1	M8	N55	N65	1.9311
Diagonal 1	M9	N65	N56	1.9311
Diagonal 1	M10	N56	N72	1.9311
Diagonal 1	M11	N72	N57	1.9311
Diagonal 1	M12	N57	N73	1.6129
Diagonal 1	M13	N74	N58	1.6129
Diagonal 1	M14	N58	N71	1.9311
Diagonal 1	M15	N71	N59	1.9311
Diagonal 1	M16	N59	N66	1.9311
Diagonal 1	M17	N66	N60	1.9311
Diagonal 1	M18	N60	N61	1.9311
Diagonal 1	M19	N61	N49	1.9311
Diagonal 1	M20	N49	N62	1.9311
Diagonal 1	M21	N62	N50	1.9311

Diagonal 1	M22	N50	N63	1.9311
Diagonal 1	M23	N63	N51	1.9311
Diagonal 1	M24	N51	N64	1.9311
Diagonal 2	M25	N50	N39	1.9311
Diagonal 2	M26	N39	N51	1.9311
Diagonal 2	M27	N51	N40	1.9311
Diagonal 2	M28	N40	N52	1.9311
Diagonal 2	M29	N52	N41	1.9311
Diagonal 2	M30	N41	N53	1.9311
Diagonal 2	M31	N53	N42	1.9311
Diagonal 2	M32	N42	N54	1.9311
Diagonal 2	M33	N54	N43	1.9311
Diagonal 2	M34	N43	N55	1.9311
Diagonal 2	M35	N55	N44	1.9311
Diagonal 2	M36	N44	N56	1.9311
Diagonal 2	M37	N56	N45	1.9311
Diagonal 2	M38	N45	N57	1.9311
Diagonal 2	M39	N57	N46	1.9311
Diagonal 2	M40	N46	N58	1.9311
Diagonal 2	M41	N58	N47	1.9311
Diagonal 2	M42	N47	N59	1.9311
Diagonal 2	M43	N59	N48	1.9311
Diagonal 2	M44	N48	N60	1.9311
Diagonal 2	M45	N60	N37	1.9311
Diagonal 2	M46	N37	N49	1.9311

Diagonal 2	M47	N49	N38	1.9311
Diagonal 2	M48	N38	N50	1.9311
Diagonal 3	M49	N37	N25	1.7187
Diagonal 3	M50	N25	N38	1.7187
Diagonal 3	M51	N38	N26	1.7187
Diagonal 3	M52	N26	N39	1.7187
Diagonal 3	M53	N39	N27	1.7187
Diagonal 3	M54	N27	N40	1.7187
Diagonal 3	M55	N40	N28	1.7187
Diagonal 3	M56	N28	N41	1.7187
Diagonal 3	M57	N41	N29	1.7187
Diagonal 3	M58	N29	N42	1.7187
Diagonal 3	M59	N42	N30	1.7187
Diagonal 3	M60	N30	N43	1.7187
Diagonal 3	M61	N43	N31	1.7187
Diagonal 3	M62	N31	N44	1.7187
Diagonal 3	M63	N44	N32	1.7187
Diagonal 3	M64	N32	N45	1.7187
Diagonal 3	M65	N45	N33	1.7187
Diagonal 3	M66	N33	N46	1.7187
Diagonal 3	M67	N46	N34	1.7187
Diagonal 3	M68	N34	N47	1.7187
Diagonal 3	M69	N47	N35	1.7187
Diagonal 3	M70	N35	N48	1.7187
Diagonal 3	M71	N48	N36	1.7187

Diagonal 3	M72	N36	N37	1.7187
Diagonal 4	M73	N35	N24	1.4768
Diagonal 4	M74	N24	N36	1.4768
Diagonal 4	M75	N36	N13	1.4768
Diagonal 4	M76	N13	N25	1.4768
Diagonal 4	M77	N25	N14	1.4768
Diagonal 4	M78	N14	N26	1.4768
Diagonal 4	M79	N26	N15	1.4768
Diagonal 4	M80	N15	N27	1.4768
Diagonal 4	M81	N27	N16	1.4768
Diagonal 4	M82	N16	N28	1.4768
Diagonal 4	M83	N28	N17	1.4768
Diagonal 4	M84	N17	N29	1.4768
Diagonal 4	M85	N29	N18	1.4768
Diagonal 4	M86	N18	N30	1.4768
Diagonal 4	M87	N30	N19	1.4768
Diagonal 4	M88	N19	N31	1.4768
Diagonal 4	M89	N31	N20	1.4768
Diagonal 4	M90	N20	N32	1.4768
Diagonal 4	M91	N32	N21	1.4768
Diagonal 4	M92	N21	N33	1.4768
Diagonal 4	M93	N33	N22	1.4768
Diagonal 4	M94	N22	N34	1.4768
Diagonal 4	M95	N34	N23	1.4768
Diagonal 4	M96	N23	N35	1.4768

Diagonal 5	M97	N22	N10	1.2997
Diagonal 5	M98	N10	N23	1.2997
Diagonal 5	M99	N23	N11	1.2997
Diagonal 5	M100	N11	N24	1.2997
Diagonal 5	M101	N24	N12	1.2997
Diagonal 5	M102	N12	N13	1.2997
Diagonal 5	M103	N13	N1	1.2997
Diagonal 5	M104	N1	N14	1.2997
Diagonal 5	M105	N14	N2	1.2997
Diagonal 5	M106	N2	N15	1.2997
Diagonal 5	M107	N15	N3	1.2997
Diagonal 5	M108	N3	N16	1.2997
Diagonal 5	M109	N16	N4	1.2997
Diagonal 5	M110	N4	N17	1.2997
Diagonal 5	M111	N17	N5	1.2997
Diagonal 5	M112	N5	N18	1.2997
Diagonal 5	M113	N18	N6	1.2997
Diagonal 5	M114	N6	N19	1.2997
Diagonal 5	M115	N19	N7	1.2997
Diagonal 5	M116	N7	N20	1.2997
Diagonal 5	M117	N20	N8	1.2997
Diagonal 5	M118	N8	N21	1.2997
Diagonal 5	M119	N21	N9	1.2997
Diagonal 5	M120	N9	N22	1.2997
Level 5	M121	N12	N1	0.6212

Level 5	M122	N1	N2	0.6212
Level 5	M123	N2	N3	0.6212
Level 5	M124	N3	N4	0.6212
Level 5	M125	N4	N5	0.6212
Level 5	M126	N5	N6	0.6212
Level 5	M127	N6	N7	0.6212
Level 5	M128	N7	N8	0.6212
Level 5	M129	N8	N9	0.6212
Level 5	M130	N9	N10	0.6212
Level 5	M131	N10	N11	0.6212
Level 5	M132	N11	N12	0.6212
Level 4	M133	N24	N13	1.2423
Level 4	M134	N13	N14	1.2423
Level 4	M135	N14	N15	1.2423
Level 4	M136	N15	N16	1.2423
Level 4	M137	N16	N17	1.2423
Level 4	M138	N17	N18	1.2423
Level 4	M139	N18	N19	1.2423
Level 4	M140	N19	N20	1.2423
Level 4	M141	N20	N21	1.2423
Level 4	M142	N21	N22	1.2423
Level 4	M143	N22	N23	1.2423
Level 4	M144	N23	N24	1.2423
Level 3	M145	N36	N25	1.8635
Level 3	M146	N25	N26	1.8635

Level 3	M147	N26	N27	1.8635
Level 3	M148	N27	N28	1.8635
Level 3	M149	N28	N29	1.8635
Level 3	M150	N29	N30	1.8635
Level 3	M151	N30	N31	1.8635
Level 3	M152	N31	N32	1.8635
Level 3	M153	N32	N33	1.8635
Level 3	M154	N33	N34	1.8635
Level 3	M155	N34	N35	1.8635
Level 3	M156	N35	N36	1.8635
Level 2	M157	N48	N37	2.4847
Level 2	M158	N37	N38	2.4847
Level 2	M159	N38	N39	2.4847
Level 2	M160	N39	N40	2.4847
Level 2	M161	N40	N41	2.4847
Level 2	M162	N41	N42	2.4847
Level 2	M163	N42	N43	2.4847
Level 2	M164	N43	N44	2.4847
Level 2	M165	N44	N45	2.4847
Level 2	M166	N45	N46	2.4847
Level 2	M167	N46	N47	2.4847
Level 2	M168	N47	N48	2.4847
Level 1	M169	N60	N49	2.847
Level 1	M170	N49	N50	2.847
Level 1	M171	N50	N51	2.847

Level 1	M172	N51	N52	2.847
Level 1	M173	N52	N53	2.847
Level 1	M174	N54	N55	2.847
Level 1	M175	N55	N56	2.847
Level 1	M176	N56	N57	2.847
Level 1	M177	N58	N59	2.847
Level 1	M178	N59	N60	2.847

Appendix B: Seismic Load Calculations

Weight, Dead Load (kN)	Weight (lbs)	Height (m)	Height (ft)	Fundamental Period, (CtHn)^x (sec)	A_v	S	C_s	V_{eq} (lbs)	V_{eq} (kN)
20.99	4719.34	3.6	11.81	0.49	0.04	1	0.077	365.25	1.6247965 47

Appendix C: Tributary Area Calculations

Joint Location	Tributary Area (m ²)	Wind (kN)	Snow (kN)	Dead (kN)	Seismic (kN)	Live (kN)	Sum of Loads at Each Joint (kN)	Number of Joints	Sum of Loads at Each Level (kN)
Base	1.8436	0.9218	0.9218	1.8436	3.6872	1.8436	9.218	10	92.18
Base Door	1.2964	0.6482	0.6482	1.2964	2.5928	1.2964	6.482	4	25.928
Level 1	3.6872	1.8436	1.8436	3.6872	-	3.6872	11.0616	8	88.4928
Level 1 Door	2.787	1.3935	1.3935	2.787	-	2.787	8.361	4	33.444
Level 2	3.2758	1.6379	1.6379	3.2758	-	3.2758	9.8274	10	98.274
Level 2 Door	3.5644	1.7822	1.7822	3.5644	-	3.5644	10.6932	2	21.3864
Level 3	2.3782	1.1891	1.1891	2.3782	-	2.3782	7.1346	12	85.6152
Level 4	1.5142	0.7571	0.7571	1.5142	-	1.5142	4.5426	12	54.5112
Level 5	0.6467	0.32335	0.32335	0.6467	-	0.6467	1.9401	12	23.2812
Totals	154.936	-	-	-	-	-	-	-	523.1128

Appendix D: Factored Load Combinations

Load Type	Value (kN/m ²)
Dead	1
Seismic	2
Live	1
Wind	0.5
Snow	0.5

Appendix E: Loads Applied at Each Joint

Level	Joints	Wind	Snow	Dead	Seismic	Live
Level 5	N1	-0.32335	-0.32335	-0.6467		-0.6467
Level 5	N2	-0.32335	-0.32335	-0.6467		-0.6467
Level 5	N3	-0.32335	-0.32335	-0.6467		-0.6467
Level 5	N4	-0.32335	-0.32335	-0.6467		-0.6467
Level 5	N5	-0.32335	-0.32335	-0.6467		-0.6467
Level 5	N6	-0.32335	-0.32335	-0.6467		-0.6467
Level 5	N7	-0.32335	-0.32335	-0.6467		-0.6467
Level 5	N8	-0.32335	-0.32335	-0.6467		-0.6467
Level 5	N9	-0.32335	-0.32335	-0.6467		-0.6467
Level 5	N10	-0.32335	-0.32335	-0.6467		-0.6467
Level 5	N11	-0.32335	-0.32335	-0.6467		-0.6467
Level 5	N12	-0.32335	-0.32335	-0.6467		-0.6467
Level 4	N13	-0.7571	-0.7571	-1.5142		-1.5142
Level 4	N14	-0.7571	-0.7571	-1.5142		-1.5142
Level 4	N15	-0.7571	-0.7571	-1.5142		-1.5142
Level 4	N16	-0.7571	-0.7571	-1.5142		-1.5142
Level 4	N17	-0.7571	-0.7571	-1.5142		-1.5142
Level 4	N18	-0.7571	-0.7571	-1.5142		-1.5142
Level 4	N19	-0.7571	-0.7571	-1.5142		-1.5142
Level 4	N20	-0.7571	-0.7571	-1.5142		-1.5142
Level 4	N21	-0.7571	-0.7571	-1.5142		-1.5142
Level 4	N22	-0.7571	-0.7571	-1.5142		-1.5142
Level 4	N23	-0.7571	-0.7571	-1.5142		-1.5142
Level 4	N24	-0.7571	-0.7571	-1.5142		-1.5142
Level 3	N25	-1.1891	-1.1891	-2.3782		-2.3782

Level 3	N26	-1.1891	-1.1891	-2.3782		-2.3782
Level 3	N27	-1.1891	-1.1891	-2.3782		-2.3782
Level 3	N28	-1.1891	-1.1891	-2.3782		-2.3782
Level 3	N29	-1.1891	-1.1891	-2.3782		-2.3782
Level 3	N30	-1.1891	-1.1891	-2.3782		-2.3782
Level 3	N31	-1.1891	-1.1891	-2.3782		-2.3782
Level 3	N32	-1.1891	-1.1891	-2.3782		-2.3782
Level 3	N33	-1.1891	-1.1891	-2.3782		-2.3782
Level 3	N34	-1.1891	-1.1891	-2.3782		-2.3782
Level 3	N35	-1.1891	-1.1891	-2.3782		-2.3782
Level 3	N36	-1.1891	-1.1891	-2.3782		-2.3782
Level 2	N37	-1.6379	-1.6379	-3.2758		-3.2758
Level 2	N38	-1.6379	-1.6379	-3.2758		-3.2758
Level 2	N39	-1.6379	-1.6379	-3.2758		-3.2758
Level 2	N40	-1.6379	-1.6379	-3.2758		-3.2758
Level 2	N41	-1.6379	-1.6379	-3.2758		-3.2758
Level 2	N42	-1.7822	-1.7822	-0.35644		-3.5644
Level 2	N43	-1.6379	-1.6379	-3.2758		-3.2758
Level 2	N44	-1.6379	-1.6379	-3.2758		-3.2758
Level 2	N45	-1.6379	-1.6379	-3.2758		-3.2758
DOOR	N46	-1.7822	-1.7822	-0.35644		-3.5644
Level 2	N47	-1.6379	-1.6379	-3.2758		-3.2758
Level 2	N48	-1.6379	-1.6379	-3.2758		-3.2758
Level 1	N49	-1.8436	-1.8436	-3.6872		-3.6872
Level 1	N50	-1.8436	-1.8436	-3.6872		-3.6872
Level 1	N51	-1.8436	-1.8436	-3.6872		-3.6872
Level 1	N52	-1.8436	-1.8436	-3.6872		-2.787
Level 1	N53	-1.3935	-1.3935	-0.2787		-2.787
Level 1	N54	-1.3935	-1.3935	-0.2787		-3.6872

Level 1	N55	-1.8436	-1.8436	-3.6872		-3.6872
Level 1	N56	-1.8436	-1.8436	-3.6872		-3.6872
DOOR	N57	-1.3935	-1.3935	-0.2787		-2.787
DOOR	N58	-1.3935	-1.3935	-0.2787		-2.787
Level 1	N59	-1.8436	-1.8436	-3.6872		-3.6872
Level 1	N60	-1.8436	-1.8436	-3.6872		-3.6872
Base	N61	-0.9218	-0.9218	-1.8436	3.6872	-1.8436
Base	N62	-0.9218	-0.9218	-1.8436	3.6872	-1.8436
Base	N63	-0.9218	-0.9218	-1.8436	3.6872	-1.8436
Base	N64	-0.9218	-0.9218	-1.8436	3.6872	-1.8436
Base	N65	-0.9218	-0.9218	-1.8436	3.6872	-1.8436
Base	N66	-0.9218	-0.9218	-1.8436	3.6872	-1.8436
Base	N67	-0.9218	-0.9218	-1.8436	3.6872	-1.8436
Base	N68	-0.9218	-0.9218	-1.8436	3.6872	-1.8436
DOOR	N69	-0.6482	-0.6482	-0.12964	2.5928	-1.2964
DOOR	N70	-0.6482	-0.6482	-0.12964	2.5928	-1.2964
Base	N71	-0.9218	-0.9218	-0.12964	3.6872	-1.8436
Base	N72	-0.9218	-0.9218	-0.12964	3.6872	-1.8436
DOOR	N73	-0.6482	-0.6482	-0.12964	2.5928	-1.2964
DOOR	N74	-0.6482	-0.6482	-0.12964	2.5928	-1.2964

Appendix F: Buckling Analysis Example for Douglas Fir-Larch

Wood Buckling Check

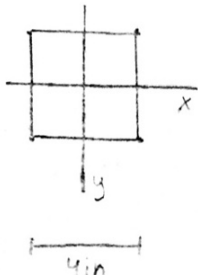

Cross section of 4x4 column

Determine Capacity using Ylinen column eqn:

$$\left(\frac{h}{d}\right)_{\max} = \left(\frac{K_e L}{\sigma_y}\right) = \frac{(1)(76.0276 \text{ in})}{3.5 \text{ in}} = 21.722$$

$$E' = E (C_m)(C_t)(C_T)(C_i) = 16000000 \text{ psi}$$

For Visually graded sawn lumber:

$$K_e = .3 \quad C = .8 \quad F_{cE} = \frac{K_e E'}{(h/d)^2} = \frac{(.3)(16000000)}{21.722} = 1017.267 \text{ psi}$$

$$F_c^* = F_c (C_D)(C_M)(C_t)(C_F)(C_i) = (1350)(1.25)(1)(1)(1.1)(1) = 1856.25 \text{ psi}$$

$$\frac{F_{cE}}{F_c^*} = \frac{1017.267}{1856.25} = .548$$

$$\frac{1 + F_{cE}/F_c^*}{2c} = \frac{1 + .548}{(2)(.8)} = .9675$$

$$C_p = \frac{1 + F_{cE}/F_c^*}{2c} - \sqrt{\left(\frac{1 + F_{cE}/F_c^*}{2c}\right)^2 - \frac{F_{cE}/F_c^*}{c}} = .9675 - \sqrt{(.9675)^2 - \left(\frac{.548}{.8}\right)}$$

$$C_p = .68508$$

$$F_c' = F_c (C_D)(C_M)(C_t)(C_F)(C_p)(C_i) = (1350)(1.25)(1)(1)(.685)(1) = 1271.58$$

$$P = (F_c')(A) = (1271.58) \times (3.5 \times 3.5) = 15576.8939 \text{ lbs} > 3960.976 \text{ lbs}$$

(interval Area of Member)