

April 2017

Smart P&IDs

Alexander John Gikas
Worcester Polytechnic Institute

Anthony Abraham Kassas
Worcester Polytechnic Institute

Follow this and additional works at: <https://digitalcommons.wpi.edu/mqp-all>

Repository Citation

Gikas, A. J., & Kassas, A. A. (2017). *Smart P&IDs*. Retrieved from <https://digitalcommons.wpi.edu/mqp-all/1594>

This Unrestricted is brought to you for free and open access by the Major Qualifying Projects at Digital WPI. It has been accepted for inclusion in Major Qualifying Projects (All Years) by an authorized administrator of Digital WPI. For more information, please contact digitalwpi@wpi.edu.



WPI

The Application of Smart Piping and Instrumentation Diagrams

A Major Qualifying Project Report submitted to the faculty of
Worcester Polytechnic Institute in partial fulfillment of the requirements
for the Degree of Bachelor of Science

Submitted by:

Anthony Kassas

Alexander Gikas

Submitted on April 26, 2017

This report represents work of WPI undergraduate students submitted to the faculty as evidence of a degree requirement. WPI routinely publishes these reports on its web site without editorial or peer review. For more information about the projects program at WPI, see <http://www.wpi.edu/Academics/Projects> .

Approved by:

Prof. Stephen J. Kmiotek, PhD

Abstract

Piping and instrumentation diagrams (P&IDs) are a universal language spoken in the process engineering industry. They are the framework of engineering design, outlining process piping, unit operations, control systems, utility management, and the functioning relationship between them within a given engineering facility. Intelligent piping and instrumentation diagrams have been created to ensure efficiency and organization in design processes through the incorporation of a back-end database of CAD drawings. In addition, intelligent piping and instrumentation diagrams promote consistency amongst instrumentation and piping denotations within the process field. We worked alongside DPS Engineering to incorporate intelligent P&IDs into the design of a small scale biodiesel transesterification process. To evaluate the potential application of intelligent P&IDs, we utilized the pilot unit operations laboratory in WPI's Goddard Hall. Through professional opinion as well as from our experience, we determined that intelligent P&IDs are an efficient organization tool for large scale projects; however, for small processes, such as the regarded biodiesel reactor, they are unnecessary.

Acknowledgements

We would like to thank the following people and organizations for their contributions:

DPS Engineering

Mike Hanson

Tim Foley

WPI

Professor Stephen Kmiotek

Professor William Clark

Acronyms and Nomenclature

CAD - Computer-Aided Design

HS - Hand Switch

ISA - International Society of Automation

KOH - Potassium Hydroxide

LC - Level Control

P&ID - Piping and Instrumentation Diagram

PFD - Process Flow Diagram

PTFE - Polytetrafluoroethylene

SEC - Speed Element Control

TAC - True Adaptive Control

TCU -Temperature Control Unit

TE - Temperature Element

TEC - Temperature Element Control

TT - Temperature Transmitter

WE - Weight Element

WT - Weight Transmitter

Table of Contents

- Abstract 2**
- Acknowledgements 3**
- Acronyms and Nomenclature 4**
- Table of Figures 7**
- Introduction 8**
 - 1.0.1 Overview 8
 - 1.02 Project Objectives 9
- Background 9**
 - 2.0.1 Computer-Aided Design 9
 - 2.0.2 Piping and Instrumentation Diagrams 10
 - 2.0.3 Process Flow Diagrams versus Piping Instrumentation Diagrams 12
 - 2.0.4 Intelligent Piping and Instrumentation Diagrams 12
 - 2.0.5 Biodiesel Production 12
 - 2.0.6 The Biodiesel Unit Operation 13
- Research Questions and Methodology 15**
 - 3.0.1 Project Objectives and Goals 15
 - 3.0.2 Project Objective Number One 16
 - 3.0.3 Project Objective Number Two 17
 - 3.0.4 Project Objective Number Three 17
 - 3.0.5 Project Objective Number Four 19
- Results and Discussion 20**
 - 4.0.1 Project Objective Number One 20
 - 4.0.2 Project Objective Number Two 23
 - 4.0.3 Project Objective Number Three 26
 - 4.0.4 Project Objective Number Four 27
- Conclusions 28**
- Recommendations 29**
 - 5.0.1 Recommendations for Intelligent P&ID Program Creators 29
 - 5.0.2 Recommendations for Future Projects and Studies 30

Bibliography	32
Appendices	34
Appendix A – Smart P&ID Revisions	34
Appendix B – Equipment List – Database Quantities.....	39
Appendix C – Instrument List – Database Quantities	42
Appendix D – Line List – Database Quantities	43
Appendix E – Professional Interviews	45

Table of Figures

Figure One – Biodiesel Transesterification Process	13
Figure Two – Process Flow Diagram	21
Figure Three – Piping and Instrumentation Diagram.....	22
Figure Four – Smart Piping and Instrumentation Diagram, Part 1	23
Figure Five – Smart Piping and Instrumentation Diagram, Part 2	24
Figure Six – Smart Piping and Instrumentation Diagram, Part 3	25
Figure Seven – Database Equipment List	26
Figure Eight – Process Flow Diagram	34
Figure Nine – P&ID	35
Figure Ten – Smart P&ID Revision A	36
Figure Eleven – Smart P&ID Revision B	37
Figure Twelve – Smart P&ID Revision C	38
Figure Thirteen – Database Equipment List, Part 1.....	39
Figure Fourteen – Database Equipment List, Part 2.....	40
Figure Fifteen – Database Equipment List, Part 3	41
Figure Sixteen – Database Instrument List.....	42
Figure Seventeen – Database Line List, Part 1.....	43
Figure Eighteen – Database Line List, Part 2	44

Introduction

1.0.1 Overview

Piping and instrumentation diagrams (P&ID) are rudimentary in chemical engineering process design works. As a fundamental blueprint to each and every chemical plant and process, piping and instrumentation diagrams offer a simplistic view on heavily quantified engineering developments, bridging the gap between process consultant engineers and construction entities. P&IDs are regarded as a flow pattern, outlining the line, valve, equipment, and instrument specifications aid engineers in developing full scale processes of all sorts. The conceptualization of intricate processes is enhanced through the capabilities of P&IDs, including, but not limited to:

- Enumerating unit operation capabilities and framework

- Maintenance of piping, instrumentation, unit operations, and valves.

- Utility tracking

- Controls engineering

- Uniformity among design engineers

- Installation methods

Piping and instrumentation diagrams are standardized by the International Society of Automation Standard S5.1 (ISA) with respect to general formatting and process diagram symbols. There, however, lies an inherent problem with the formulation of piping and instrumentation diagrams. Each AutoCAD designer utilizes a unique method in their construction of process schematics, resulting in an ununiformed series of P&ID pages of large scale processes. An entity taking on a project of greater magnitude with several tens of pages of P&IDs cannot properly level the playing field without providing edits upon edits of material. Changes to process dynamics and operations must then be reflected in the agreeing Microsoft Excel database of specifications. Process edits are not reflected universally under current software restrictions. This evolving problem is most evident under grander scale processes. This

project seeks to explore the capabilities of intelligent piping and instrumentation diagrams, the efficiency of the technology, and the scale-up potential related to the related software. A biodiesel transesterification process was studied in order to discern the plausibility of these objectives.

1.02 Project Objectives

The goal of this project was to work alongside DPS Engineering to determine the applicability of intelligent P&IDs into process engineering on small and large scales. Our major objectives were to:

1. Create an operation piping and instrumentation diagram that accurately depicts the biodiesel transesterification operation in the Unit Operation Laboratory of Goddard Hall.
2. Replicate the piping and instrumentation diagram in CADWorx. Retrieve Excel database of equipment lists and specifications.
3. Determine the plausibility of scale up with regards to the biodiesel transesterification operation and other Smart P&ID implemented projects utilizing CADWorx and professional opinion.
4. Assess the efficiency of Intelligent P&ID technology.

We hope that intelligent P&IDs will prove to be a helpful tool in process engineering and that it becomes a universally used program to better the industry.

Background

2.0.1 Computer-Aided Design

Computer-Aided Design (CAD) is a software program that was released in the 1960s with the intention to assist in the creation, modification, analysis and optimization in range of industries.

¹ Utilized by architects, engineers, and artist, Computer-Aided Design enables an author to conceptually create an accurate 2-D vector based or 3-D solid based representation of a technical drawing. CAD replaces drafting by hand with computer simulated drawing with

¹ Market Business News – What is Computer-Aided Design or CAD

greater precision. CAD is used to design houses, cars, unique products, and piping and instrumentation diagrams. ² AutoCAD is the predominant CAD platform used by operating facilities for piping and instrumentation diagrams.

2.0.2 Piping and Instrumentation Diagrams

Piping and instrumentation diagrams are the framework of engineering design, outlining the process piping, unit operations, control systems, utility management, and the functioning relationship between them within a given engineering facility. A piping and instrumentation diagram portrays unique symbol representation of components and instruments along with their functions and locations on a multipage document, employed for troubleshooting and monitoring processes. P&IDs portray a layout scheme used by members of development teams to accurately assess construction processes, maintenance guidelines, and the fundamental blueprints of how a process may start up, operate, and shutdown. P&IDs are often considered to be a liaison between equipment manufacturing and process construction and operation. By the definition provided by Lucid Chart, “P&IDs play an essential role in the process engineering world to show interconnectivity. P&IDs are invaluable documents to keep on hand, whether they’re used to streamline an existing process, replace a piece of equipment, or guide the design and implementation of a new facility.” ³ The unique attributes credited to the P&ID enable engineers and others involved in the process to responsibly attend to the process and understand the rudimentary dynamics of it.

Piping and instrumentation diagrams include all controlled locks, mechanical equipment, and unit and unique piping labels. Flow directions are depicted to allow examiners to conceptualize process pathways from storage vessels in the commencement of a chemical or biological process, to product and waste vessels downstream. The intended physical sequence of the equipment is displayed through the provided flow direction indicators. ⁴ Omitted from piping and instrumentation diagrams are specificities of equipment and their usage, along with proper

² AutoDesk – CAD Software

³ Lucid – What are Piping and Instrumentation Diagrams?

⁴ Engineering ToolBox – P&IDs

scaling, to an extent. Piping size and identification are noted, yet piping length is omitted in most situations. Scaling between different unit operations and piping length are factors of safety and accessibility analyses, separate of piping and instrumentation diagrams. Piping and instrumentation diagrams are physically implemented as depicted on the diagram; e.g., a valve should be correctly rotated based on its positioning on the P&ID; a storage vessel should be correctly aligned based on the positioning of the P&ID and a piping inlet into a unit operation should not be constructed in an outlet. “It is noted that the P&IDs are to be suitable for a take-off of the valves, reducers, branches, and instruments, but not for the take-off of piping and elbows”⁵ With that being said, P&IDs cannot be “relied on as real models” due to their lack of geometric and scaling accuracy.⁶ P&IDs often vary in design from creator to creator due to the lack of universal guideline. It is also customary to avoid the flow qualifications and extended disclaimers regarding the process in such a diagram.

The usage of piping and instrumentation diagrams can assure safety protocol is being followed via operation guidelines, as well as assure costs of maintenance and construction. By developing a standard operation guideline, a community of process employees can rightfully adhere to provided rule parameters. P&IDs can yield an accurate feel of pricing with the planning of all piping and unit operations. Despite inherent inconsistencies, piping and instrumentation diagrams deliver measures of operation security, proper usage, as well as strict maintenance and construction policy.

2.0.3 Process Flow Diagrams versus Piping and Instrumentation Diagrams

Piping and instrumentation diagrams diverge from process flow diagrams (PFD) through many facets. Provided by the International Society of Automation, “[A process flow diagram is a] drawing that shows the general process flow between major pieces of equipment of a plant and the expected operating conditions at the target production rate.”⁷ Containing supplementary detail, P&IDs are considered to be a more advanced step into the design process, whereas PFDs are referred to as a bird’s eye view. Process flow diagrams show the interconnectivity of main

⁵ Unica Instrument Engineer’s Handbook – Process Measurement and Analysis

⁶ Lucid – What are Piping and Instrumentation Diagrams?

⁷ ISA – Control and Field Instrumentation Documentation

equipment operations, yet omit detail further, as opposed to P&IDs. In addition, PFDs do not include ISA symbols, but are the evolution of most P&ID schematics.

2.0.4 Intelligent Piping and Instrumentation Diagrams

In 1985 Intergraph introduced the first SmartPlant P&ID systems.⁸ Intelligent P&IDs, or Smart P&IDs, are data driven CAD drawings with a back-end database. This database bridges other applications, which populate information and extract them from the drawings. It also allows the designer to manage the P&ID while focusing on the plant asset rather than the document representation. The information stored with each intelligent P&ID consists of the minimum required attributes for design, analysis, procurement, and maintenance.⁹ The inputs are retrieved from process flow sheets, instrumentation schematics, equipment data sheets, valve and instrumentation specification sheets, and piping material specifications. It can be provided in the form of drawings and documents. A variety of software allows for visual representation of a given P&ID, as AutoCAD would provide, yet enables interactivity. Identification, physical properties, process responsibilities, utilities, current statuses, and miscellaneous information can be accessed through touch of the computer mouse of the corresponding portion of the P&ID. Quoted from the producers of SmartPlant P&IDs, Intergraph describes the software as a means to “help you develop and manage your P&IDs with a focus on the plant asset...helping you save money without compromising design quality or integrity.”¹⁰ The hopeful outcome of intelligent P&IDs is that it will save money, time, and reduce risk for the longevity of the construction and operation of the process.

2.0.5 Biodiesel Production

As energy demands increase, and fossil fuels are limited, research is directed towards alternative renewable fuels. Biodiesel is a favorable liquid biofuel alternative because it is made

⁸ Intergraph News – SmartPlant Enterprise

⁹ All About CAD Conversion – What are Intelligent P&IDs

¹⁰ Intergraph News – SmartPlant Enterprise

from renewable resources, vegetable oil and methanol, and has lower emissions.¹¹ It is less toxic than table salt and biodegrades as fast as sugar. Produced domestically with natural resources, its use decreases universal dependence on imported fuel and contributes to economic development. The increase of research on reducing biodiesel production costs has strengthened the industry, making it a strong competitor of petroleum based fuels.

The production of biodiesel fuel is a multi-reaction process involving complex set of conditions and controls. A preliminary step to biodiesel production is the chemical process known as transesterification, where glycerol is separated from oil with the use of methanol and a base catalyst (KOH). The process leaves behind two products consisting of methyl esters and glycerol. Vegetable oil has an extremely high viscosity so it is not the most efficient when burned, however transesterification converts the vegetable oil to biodiesel molecules that have similar properties to petroleum diesel fuel. Due to the great molecular similarities, this alternative fuel has a chance of fulfilling the demands that diesel engine makes of its fuel. The scope of this reporting of the biodiesel production process is limited to the transesterification reaction noted above for the sake of creating an intelligent P&ID system.

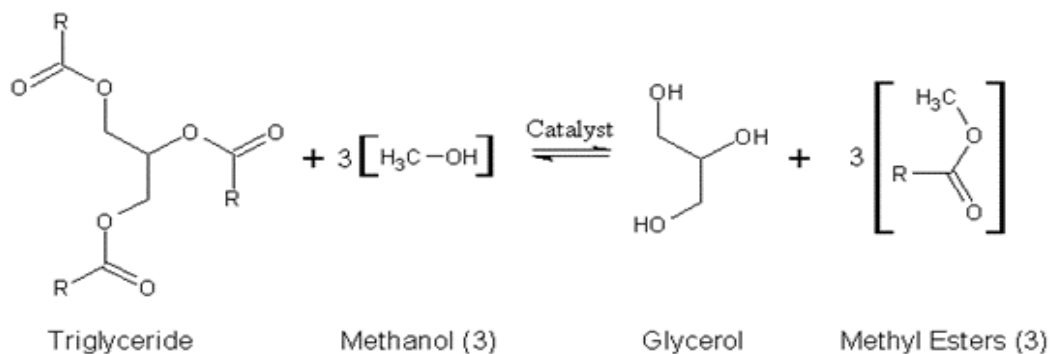

Figure 1: Biodiesel Transesterification Process

Above is the chemical reaction for the production of biodiesel from vegetable oil using methanol. Ethanol is an available substitute for methanol. When utilized, three methanol or

¹¹ Biodiesel Basics – Biodiesel.org

ethanol molecules react with triglyceride to form three molecules of ethyl esters. These methyl or ethyl esters are the biodiesel products sought.

2.0.6 The Biodiesel Unit Operation

The piping and instrumentation diagram generated replicates the biodiesel production unit operation within the Worcester Polytechnic Institute, Goddard Hall second floor unit operations laboratory. The diagram was computer emulated on AutoCAD to retrieve a schematic of the entire process.

The biodiesel production process of interest encompasses a 500 milliliter Globe Chemical Reactor, with a glass jacket, used as a catalyst preparation reactor. The production unit operations follow to a 500 milliliter Globe Chemical Reactor, with a glass jacket, used as a process reactor. Each reactor contains a pitched polytetrafluoroethylene (PTFE) blade propeller for mixing purposes as well as a spring loaded valve which provides leak free sealing. The reactors are connected via $\frac{3}{16}$ " ChemDurance Bio tubing, from the preparatory reactor lower manual valve to the top of the process reactor. Each reactor has a respective temperature element (TE) and temperature transmitter (TT). Connected to each jacketed reactor is a condenser loop. The $\frac{1}{2}$ " rubber tubing of the condenser loop carries sewer water to each Huber MiniStat temperature regulator from the jacket of each reactor and back to the jacket in order to respectively control the designated process temperature. This process is regulated by the temperature control unit (TCU) self-optimizing temperature element control (TEC) with a temperature error stability rate of ± 0.02 degrees Celsius. Heating capacity of the condenser reaches 1.5 kW and cooling capacity ranges from 0.42 to 0.05 kW.

The stored process materials are held within 2000 milliliter Nalgene Erlenmeyer Polypropylene Flasks. These stored process materials include methanol, ethanol and vegetable oil. It is, again, worth noting that either methanol or ethanol is used during the process, not in conjunction. The potassium hydroxide (KOH) catalyst is manually inputted into the catalyst preparation reactor with the methanol or ethanol. The vegetable oil mixes with the catalytic reactor mixture

in the process reactor. Generic weigh scales are used to track the weight of each stored process material (aside from the catalyst) to regulate the input into the corresponding reactor. Regulation is completed by means of gravimetric dosing from the feed vessels on electronic balances, utilizing a weight element (WE) and a weight transmitter (WT). Stored materials are transferred from their respective flask to the designated reactor by $\frac{3}{16}$ " ChemDurance Bio tubing.

Watson Marlow SCI 323 peristaltic pumps transfer the contents of each piece of ChemDurance Bio tubing to their obligated location. There are three peristaltic pumps located in the unit operation: one for the feed pumping of methanol or ethanol, one for the feed pumping of vegetable oil, and one for the transfer of contents from the catalytic reactor to the process reactor. Each pump is associated with a speed element control (SEC) and a hand switch (HS). An equivalent $\frac{3}{16}$ " piece of ChemDurance Bio tubing is attached to the manual spring valve at the bottom of the process reactor, in which a mixture of glycerol and biodiesel are gravimetrically transferred to and separated in a Justrite Polyethylene 5 Gallon Quick-Disconnect Disposal Safety Can.

Research Questions and Methodology

3.0.1 Project Objectives and Goals

The goal of our project was to work alongside DPS Engineering to determine if incorporating intelligent P&IDs in process engineering is efficient and scalable. In order to accomplish this goal we pursued four objectives:

1. Create an operation piping and instrumentation diagram that accurately depicts the biodiesel transesterification operation in the Unit Operation Laboratory of Goddard Hall.
2. Replicate the piping and instrumentation diagram in CADWorx. Retrieve Excel database of equipment lists and specifications.

3. Determine the plausibility of scale up with regards to the biodiesel transesterification operation and other Intelligent P&ID implemented projects utilizing CADWorx and professional opinion.
4. Assess the efficiency of Intelligent P&ID technology.

In this section, elaboration on these objectives and explanations regarding the necessary process to complete these objectives will be discussed.

3.0.2 Project Objective Number One

Objective One: Create an operation piping and instrumentation diagram, in AutoCAD, that accurately depicts the biodiesel transesterification operation in the Unit Operation Laboratory of Goddard Hall.

Preliminary Research

The preliminary research conducted prior to the production of the process and instrumentation diagram of the biodiesel transesterification process began with the familiarization with AutoCAD. As two novice CAD operators, adaptation to the program proved difficult, with plenty of hours of introductory practice being conducted. A thorough examination of features of the Goddard Laboratory biodiesel pilot plant was conducted. A rough PFD was conceptualized and sketched in order to further understand flow patterns and the major pieces of equipment. Tubing and equipment models and serial numbers were taken into account to determine exact specifications of the entire process. Additionally, piping and instrumentation diagrams consist of several different detailed figures representing unit operations of a given operation. Without licenses to obtain premade instruments, we had to examine pre-existing and industry standardized P&ID symbols for unit operations.

Method

The piping and instrumentation diagram was completed in AutoCAD. Many drafts were made, due to uncertainty of various pieces of equipment. Re-creation of representational unit operations as our own was conducted via our AutoCAD drawings. Once the major operations

such as reactors, heat exchangers, pumps, and valves were drawn, we then connected them by piping. Level and temperature controls were followed by the piping in order to place them in a more comprehensible manner. Arrows were also added to provide a direction in the process flow. Finally, we labeled the equipment with proper nomenclature to elaborate on the sizing and material of piping, as well as differentiate the duplicate instruments.

Limitations and Obstacles

Not all information regarding the piping was at our exposure. Even with research, the exact make and size of the condenser loop tubing was not apparent due to a language barrier of the producer and us. With consulting from Professor William Clark, an estimate of the piping diameter and material was completed of said tubing line.

We were exposed to many different alternate standardized drawings of specific instruments when completing prior research. There is no one method in drawing a peristaltic pump; however there are abundant alternatives. The drawings we made were based off of the resemblance to the actual equipment.

3.0.3 Project Objective Number Two

Objective Two: Replicate the piping and instrumentation diagram in CADWorx. Retrieve Excel database of equipment lists and specifications.

Preliminary Research

Prior to utilizing CADWorx, there had to be a strong understanding of the program itself. DPS provided us with a manual on operating and maneuvering through CADWorx. In order to successfully complete this step, with the least amount of hiccups and errors, many questions were asked. Approximately twenty hours were spent reading the manual, and speaking to employees about instruction and applicable tips. Background research on the equipment specifications was also completed in order to maximize the advantage of intelligent P&IDs.

Method

The P&ID produced in AutoCAD was first uploaded through CADWorx. Once it was displayed, edits had to be made in order for the program to better understand the functions of the process. Equipment was made intelligent by highlighting and including specifications, which are included at the bottom on the modified intelligent P&ID. The P&ID was transferred to a database called Schema DBO. Schema DBO is used to organize projects and information regarding the intelligent P&IDs. Once the process was filtered out, we found four lists that were systematically organized. An equipment list, instrument list, valve list, and line list were all produced.

Limitations and Obstacles

This objective most complicated and led to providing us with many limitations and obstacles. The P&ID did not smoothly transfer over to CADWorx, due to the lack of recognition. Equipment, instruments, valves, and lines were altered manually in a similar manner to AutoCAD.

The specifications that we provided the program with may have slight differences than that of the process in Goddard Hall. We were limited on data regarding the exact models and companies who produce the equipment. Educated guesses were made to fill the slots of the unknown specs. Although we did not want to make guesses about the equipment, it would have defeated the purpose of applying intelligent P&ID to not include specs.

The transition from the database to the Excel sheets was not fluent. Information given in the specs was forcibly rearranged in CADWorx to make it apparent in the bottom corner of the P&ID. Due to this alteration, the information provided in the Excel sheets was jumbled. Manual changes had to be made to move the proper specifications to the corresponding equipment. Needless to say, this was a timely and tedious problem to fix.

3.0.4 Project Objective Number Three

Objective Three: Determine the plausibility of scale up with regards to the biodiesel transesterification operation and other Intelligent P&ID implemented projects utilizing CADWorx and professional opinion.

Preliminary Research

The intelligent P&ID manual provided by DPS was our means of prior research on scalability possibilities.

Method

The manual provided no information regarding scaling up a project, such as the biodiesel process. In order to determine the feasibility the next approach was to seek assistance from someone who uses this program on a daily basis. After a series of conversations and interviews it was easy to determine that intelligent P&IDs do not scale processes directly. Quoted by our sponsor advisor, Michael Hanson, "Scale-up would require manual manipulation of the data. This can be done easily in Excel (i.e. increase size of line and equipment) then upload the scaled-up parameters to the database" ¹² Smart P&IDs can help make additions to projects which are already programmed through CADWorx. With information already provided in the database, adding to the process can be easily done.

Limitations and Obstacles

Few limitations and obstacles were included in this step. The purpose of intelligent P&IDs is not to scale up a project, and there is no way to do so through the program.

3.0.5 Project Objective Number Four

Objective Four: Assess the efficiency of Intelligent P&ID technology.

Preliminary Research

Minimal preliminary research was done to determine the efficiency of Smart P&IDs. Word of mouth in industry and through relative internship experiences gave light to this regarded study. Intelligent P&IDs have proven to be a time saving tool according to industry leaders. With little

¹² Interview – Michael Hanson – DPS Engineering

knowledge of the program, DPS process engineers recommended the idea of completing a project on the innovative program.

Method

Through our experience, as well DPS employees' experiences, we evaluated the efficiency of Smart P&IDs by comparing how our project would have differed if conducted without the use of Smart P&IDs. Variables that were considered were time, error, and software preference and comfortability. In order to obtain a full range of perspectives we had multiple industry participants complete a survey.

Limitations and Obstacles

A greater population of process engineers could have been interviewed on the topic of Smart P&IDs. A wider range of firms could have been examined in their experiences with Smart P&ID software. If our project consisted of a greater timeline, it would have been possible to time a series of Smart P&IDs implemented projects and assess error. Instead, only one process design was completed. CADWorx had a large learning curve, which prevented us from optimizing the benefits. Given more experience prior to completing the project would have allowed us to develop stronger, more informed opinions regarding Smart P&IDs. Mastery of such an intricate software tool takes years upon years.

Results and Discussion

4.0.1 Project Objective One

Objective 1: Create an operation piping and instrumentation diagram that accurately depicts the biodiesel transesterification operation in the Unit Operation Laboratory of Goddard Hall.

As a preliminary step to a piping and instrumentation diagram, a process flow diagram was created to better understand the biodiesel transesterification process at hand. The process flow diagram consists of three vessels, notated as V-1, V-2, and V-2 in rectangular formations which contain reaction substituents. V-4 is also denoted at the end of the process as the collection tank. In addition, three pumps were found in the process, and notated similarly by P-1, P-2, and

P3, transporting reactants and reaction mixtures to their appropriate places. Two reactors, central to the process are symbolized by R-1 and R-2. As mentioned prior, R-1's purpose was a catalytic preparatory reactor while R-2 served the purpose of the process reactor. The biodiesel transesterification process process flow diagram is as follows:

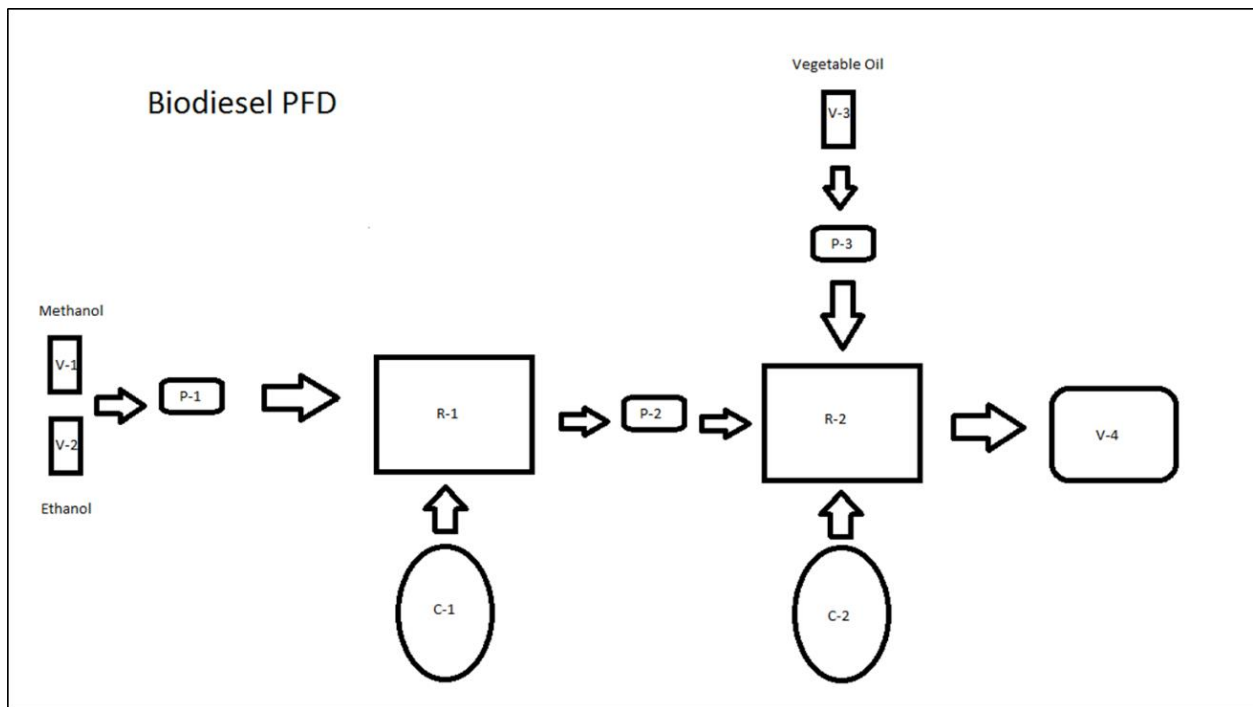

Figure 2: Process Flow Diagram

Subsequent to the process flow diagram was the creation of a piping and instrumentation diagram illustrated below. Straight lines were comparable to solvent and sewer lines while dashed lines signified instrumentation connections. As an early revision, condensers were illustrated to represent the temperature control units of the process. In addition, the vessels of the P&ID were shown as half-filled circles which were later amended to better visualize the process dynamics and unit operations involved. True adaptive controls (TAC) were found to be the temperature regulation system of each reactor, while a level control (LC) was drawn to signify the measurement means between the feed and pump interaction. After better comprehension and discussion with Professor Clarke and Professor Kmiotek occurred, these controls were expanded upon in later P&ID revisions within CADWorx software. These revisions

are viewable in Appendix A. Line labels were written in the form of X"-SVC-ET:SQ-LS. X denoted the piping diameter. SVC represented the service, or type of fluid carried by the line. ET denoted the unit operation of origin, while SQ was a unique line number given to each pipe. LS represented the abbreviated material structure of the line. Pumps and reactors were drawn to most closely replicate the process units through the deliberate adhesion of a jacket to each reactor, and the unique mechanics of peristaltic pumps.

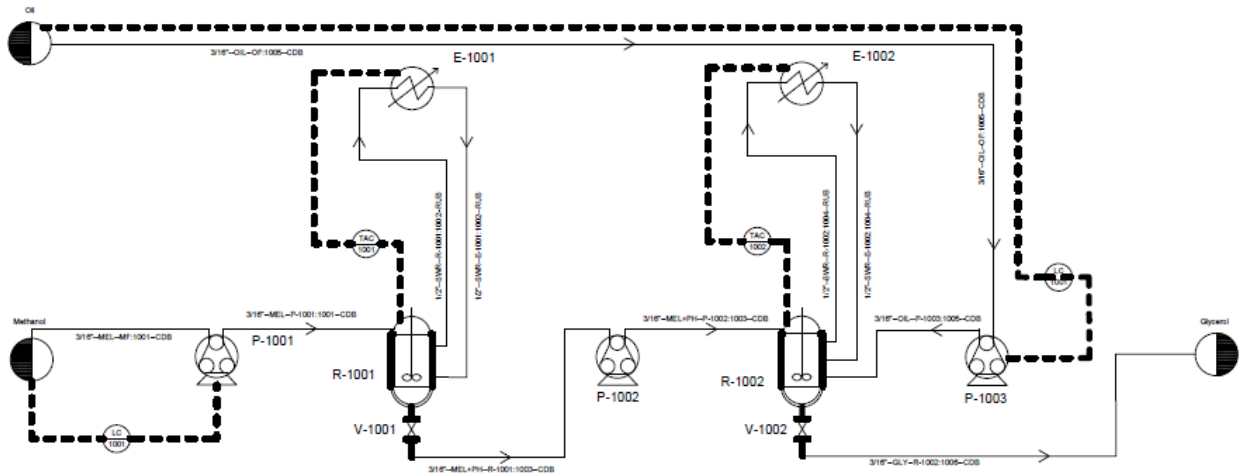

Figure 3: Piping and Instrumentation Diagram

4.0.2 Project Objective Two

Objective 2: Replicate the piping and instrumentation diagram in CADWorx. Retrieve Excel database of equipment lists and specifications.

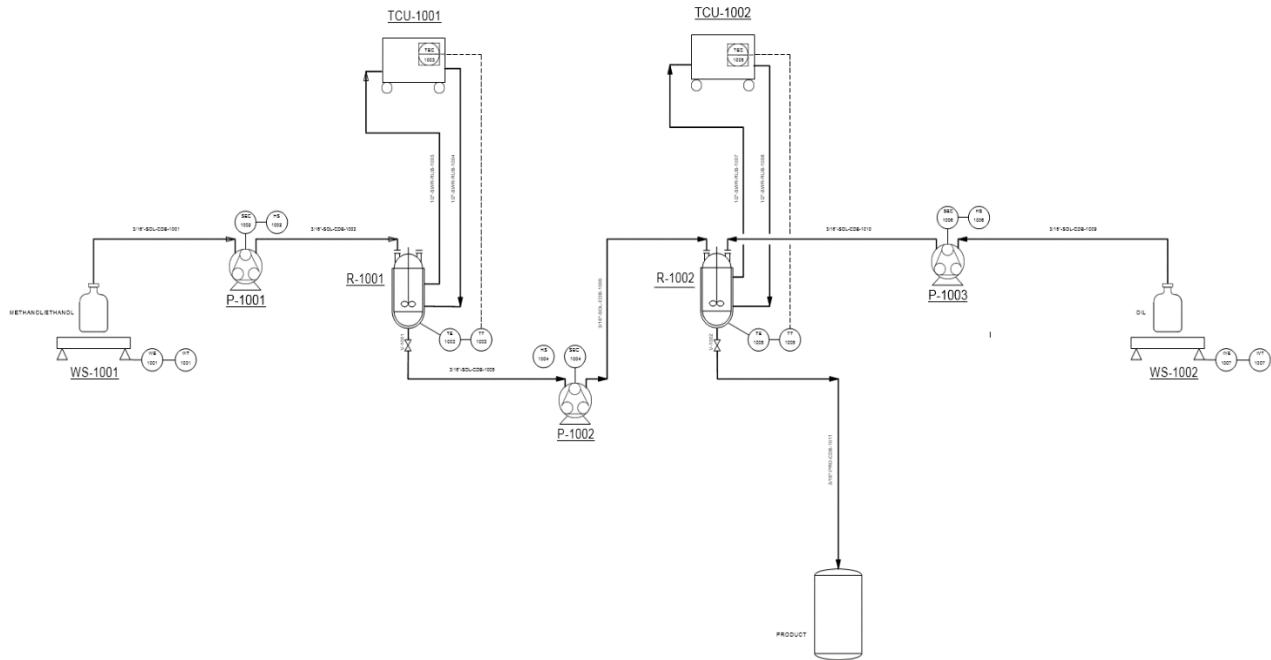

Figure 4: Smart Piping and Instrumentation Diagram, Part 1

Revision D of the Smart P&ID included several additions to the maiden piping and instrumentation diagram shown above. Each reactor (R-1001 and R-1002) consists of injection nozzles at the top of each, R-1001 consisting of a manual injection point for the KOH catalyst. Each reactor, in addition, underwent an instrumentation change. Temperature elements and temperature transmitter were added to instrumentation lines which are in conjunction with the adapted temperature control units. Each temperature control unit consists of a temperature element control which is in direct signal to the reactor instrumentation. The line name template was changed out of simplification reasoning, following the form X"-SVC-MAT-#, where X represents the line diameter, SVC the fluid service, MAT the line material, and # represents the unique line number. Each reactant set up was changed to incorporate an appropriate weigh scale and a bottle symbol as representation of the Erlenmeyer flask in the biodiesel transesterification process. Each weigh scale has a corresponding weight element and weight

transmitter to suitably apportion the correct amount of reactant to each reactor. Pump instrumentation consists of a speed element control and a hand switch. The product line was moved to better depict the gravity feed into the product tank (TK-1001).

TAG No.	WS-1001	P-1001	R-1001	TCU-1001	P-1002	R-1002	TCU-1002	WS-1002	P-1003	TK-1001
EQUIPMENT	WEIGH SCALE	PERISTALTIC PUMP	CHEMICAL REACTOR	TEMP CONTR UNIT	PERISTALTIC PUMP	CHEMICAL REACTOR	TEMP CONTR UNIT	WEIGH SCALE	PERISTALTIC PUMP	QUICK DISCONNECT CAN
DESCRIPTION		313D, 314D PUMP HEADS	JACKETED CATA PREP	PORTABLE	313D, 314D PUMP HEADS	JACKETED PROCESS	PORTABLE		313D, 314D PUMP HEADS	
MATERIAL			PTFE AND GLASS	STAINLESS STEEL		PTFE AND GLASS	STAINLESS STEEL			POLYETHYLENE
SIZE/CAPACITY	12000 GRAMS	15-400 RPM	250 mL		15-400 RPM	500 mL		12000 GRAMS	15-400 RPM	5 GALLONS
DESIGN PRESS. BAR			50 mbar-0.25 bar	0.4-0.7		50 mbar-0.25 bar	0.4-0.7			
DESIGN TEMP. °C	10-40	4-40	-90-200	-40-200	4-40	-90-200	-40-200	10-40	4-40	
MANUFACTURER/MODEL	OHAUS EP12001	WATSON MARLOW SCI.323	SYRRIS GLOBE REACTOR	HUBER MINISTAT	WATSON MARLOW SCI.323	SYRRIS GLOBE REACTOR	HUBER MINISTAT	OHAUS EP12001	WATSON MARLOW SCI.323	JUSTRITE PP12755
ELECTRICAL SUPPLY	100-120V AC, 220-240V AC			208V/3PH/2.5KW			208V/3PH/2.5KW	100-120V AC, 220-240V AC		
REMARKS	STND DEV = 0.1		2000 RPM, PITCH BLADE	0.02 TEMP STABILITY		2000 RPM, PITCH BLADE	0.02 TEMP STABILITY	STND DEV = 0.1		MFPHOSHA COMPLY

Figure 5: Smart Piping and Instrumentation Diagram, Part 2

Coupled with the Smart P&ID is a visible data sheet incorporated directly onto the P&ID. The data sheet shows inputted values of equipment description, material, capacity, pressure, temperature, manufacturer/model, and electrical supply. Said specifications were researched to the best of our ability and inputted via smart tagging of each unit operation.



WPI



DPS

NOTES:

1. GRAVITY FED FROM R-1002 TO TK-1001.
2. PRODUCT AND WASTE APPORTIONED INTO SEPARATE DENSITY LAYERS IN R-1002 AND TRANSFERRED INTO TK-1001 .
3. R-1001 AND R-1002 CONSIST OF HIGH PERFORMANCE BOTTOM OUTLET VALVES WITH CHEMICAL RESISTANCE AND LEAK DETERRENCE.
4. MANUAL INJECTION OF CATALYST (KOH) INTO R-1001.
5. R-1001 AND R-1002 LIQUID LEVELS ARE MANUALLY CONTROLLED AND MONITORED.

Figure 5: Smart Piping and Instrumentation Diagram, Part 3

An allotted area was designated to further describe the process and answer any questions an onlooker may have concerning the process. Five notes were added, as shown above, to justify the drawing.



IDENTIFICATION					INFORMATION	
ID	Tag No.	P&ID No.	Location	Room No.	Equipment Type	Manufacturer
3200026	P-1001	ALEXANTHON	GH Unit Ops Lab	1	PERISTALTIC PUMP	WATSON MAR
3200089	P-1002	ALEXANTHON	GH Unit Ops Lab	1	PERISTALTIC PUMP	WATSON MAR
3200093	P-1003	ALEXANTHON	GH Unit Ops Lab	1	PERISTALTIC PUMP	WATSON MAR
3200021	R-1001	ALEXANTHON	GH Unit Ops Lab	1	CHEMICAL REACTOR	SYRRIS
3200090	R-1002	ALEXANTHON	GH Unit Ops Lab	1	CHEMICAL REACTOR	SYRRIS
3200062	TCU-1001	ALEXANTHON	GH Unit Ops Lab	1	TEMP CONTR UNIT	HUBER
3200091	TCU-1002	ALEXANTHON	GH Unit Ops Lab	1	TEMP CONTR UNIT	HUBER
3200118	TK-1001	ALEXANTHON	GH Unit Ops Lab	1	QUICK DISCONNECT CAN	JUSTRITE
3200104	WS-1001	ALEXANTHON	GH Unit Ops Lab	1	WEIGH SCALE	OHAUS
3200103	WS-1002	ALEXANTHON	GH Unit Ops Lab	1	WEIGH SCALE	OHAUS

Figure 6: Database Equipment List

Following the creation of the Smart P&ID, a database could be retrieved of all the information of each unit operation. Above is a portion of the extended Microsoft Excel data outputted by CADWorx and Schema DBO database software. Equipment specifications are neatly listed and configured into a table to better track, update, and create lines, equipment, valves, and instrumentation. CADWorx allows for the editing of a P&ID and direct, and automatic, editing of the correct database sheets after a re-upload to Schema DBO database software is complete.

4.0.3 Project Objective Three

Objective 3: Determine the plausibility of scale up with regards to the biodiesel transesterification operation and other intelligent P&ID implemented projects utilizing CADWorx and professional opinion.

- Direct scale up capabilities are not present within the CADWorx intelligent P&ID infrastructure.

- Additions to projects can be completed easily.

After experimenting with CADWorx and reading through DPS's user manual, we determined that scaling up a project is technically feasible with the program, yet there is no clear method of doing so. The program does allow additions to be made to the process easily, but there is no option present to upscale or downscale the whole entire process. Smart P&IDs are tool to make designing a process easier in the industry, but not necessarily scaling to a greater size. Typically a P&ID is designed and then built following the drawing. In our study, the biodiesel transesterification process was built already, and then we used AutoCAD and CADWorx to replicate it into a P&ID. Because we worked backwards from a typical engineering firm's experience, we expected the program to offer benefits that are not quite necessary, such as scaling up, to a typical engineering firm.

4.0.4 Project Objective Four

Objective 4: Assess the efficiency of Intelligent P&ID technology.

- Intelligent P&ID technology is effective on large scale processes and operations through uniformity.
- Intelligent P&ID systems often are considered excessive for processes such as pilot plants as observed in this study.
- Efficiency of the technology improves as project scale increases and a greater number of CAD operators are involved.

After experimenting with Smart P&IDs and interviewing experienced process engineers we determined that CADWorx is efficient given the proper context. Integrating Smart P&IDs into a company can be difficult, as it has a large learning curve. Information must be put in prior to

using the program in order for it to be specialized to the company it is complying with. Once this is completed, and operators understand how to use the program, it becomes more efficient. As the project becomes larger, and more CAD operators are involved, more time is saved. Many CAD operators prefer this program because it forces them all to work in a uniform sequence. Less risk is involved with Smart P&IDs because of how the information transitions between the drawing and Excel files. Employees are less worried about making mistake when changes to the process need to be made.

On a smaller scale process, such as the biodiesel transesterification pilot process, Smart P&IDs are not worth spending the time to integrate. Since we already had a basic understanding of AutoCAD and Microsoft Excel, a one page process was not intense. Instead we spent most of our time to learn how to use the Smart options within CADWorx. If the process was much larger, then it would have been more efficient. If we already knew how to operate CADWorx prior to this project, then it probably would have taken around the same time as creating a regular P&ID and Microsoft Excel sheets.

Conclusions

Smart P&IDs are useful to process engineering consulting firms for many reasons. The capabilities of Smart P&IDs are as follows:

1. Customize attribute blocks (instruments, IO, valves, lines, equipment, etc.) following ISA standard.
2. Insert attribute blocks to P&ID AutoCAD drawings.
3. Save AutoCAD files to DXF (Drawing Exchange Format) file format. It's a text compatible format that can be edited by Word, Text editor, etc.
4. Run visual basic program to import attribute data from DXF file into Access database. Another VB program can export attribute data. It's bi-directional.
5. Customize Access database queries, macros, forms, reports, etc. to generate all the reports. These were used in Schema DBO database software.
6. Export/Import data between database and Excel spreadsheets as required.

As a research investigation, we found that Smart P&IDs have a unique place in industry, providing efficiency and uniformity across projects of all sizes. We found that Smart P&IDs are, indeed, more efficient in larger scale processes through this uniformity factor. Keeping a team of AutoCAD designers on a similar track provides risk depression along with the unique interactivity between database and P&ID. Smart P&IDs are a promising piece of technology with growing popularity which has a tremendous opportunity to craft a great imprint on the process engineering industry.

Recommendations

5.0.1 Recommendations for Intelligent P&ID program creators

CADWorx software provided the fundamental application of tying a piping and instrumentation diagram into a database in a simplistic form, eliminating the necessity of manual entry. Our project group sought to experiment with the capabilities of CADWorx software in scaling process up or down in size. Upon inspection of the software capabilities, it was apparent that addition of unit operations within a P&ID drawing was simple in nature and allowed an easy transition into database held specifications of the operations. Yet, a direct operation enabling scalability was not present in the infrastructure of the software. Pilot plants are abundant in industry in order to assess a project before the investment of a full scale comes into play. The software capability to bring these pilot plants to full scale and beyond would prove useful. We recommend the implication of this ability into CADWorx and other intelligent piping and instrumentation diagram software to better the process development field.

The database associated with unit operation specifications within CADWorx was customizable. Any desired specifications of the entire process could be made visible if specified, up to a certain amount. For example, in our study of the biodiesel transesterification process, the first catalytic preparatory reactor (R-1001) was made of PTFE, better known as polytetrafluoroethylene. Our group was forced to list this specification as PTFE under the condition that the chemical compound's nomenclature could not fit in the table in the bottom right hand corner of the intelligent P&ID. In addition, CADWorx only allowed for the specification of equipment description, material, size, pressure, temperature, manufacturer,

and electrical supply. The limit on unit operation specifications proved inadequate when trying data entering for the biodiesel transesterification process. Both reactors (R-1001 and R-1002) were, as a result, underspecified in the table in the bottom left hand corner of the intelligent P&ID. We recommend that CADWorx and other content creators make the visible specifications further customizable by increasing the data entry length and including the option of what specifications you would like to show for each piece of equipment instead of having to pick a concrete set of specifications that you must enter for each unit. Again, the specificities of the process are by far the most important portion of the software, and should not be hindered as explained.

5.0.2 Recommendations for Future Projects and Studies

Intelligent piping and instrumentation diagrams are not used as frequently as they could be. Projects have the potential to be completed in a more efficient manner if companies utilized this program. It would be more appealing to process firms if there were statistics which stated the amount of time that would be saved if intelligent P&IDs were implemented. We recommend that a future team determines statistical data on how much time is saved when implementing this technology into a process design project. A cost analysis could also be done to show how much money will be saved from a decrease in hours and employees invested into a project.

Once it was evaluated that our biodiesel pilot plant was too small to utilize Smart P&IDs properly, the question arose inquiring the optimum process size deeming Smart P&IDs useful, and exactly where that line is drawn. This would be insightful for process firms to determine whether or not to consider using Smart P&ID software.

Multiple Smart P&ID programs have been created by different companies. Two others besides CADWorx are SmartPlant P&ID and OpenPlant P&ID. With little knowledge regarding these programs, it would be of value to research and study the differences between their capabilities. Perhaps one is more useful with certain process types over others. Determining the proper application for each program would help the industry choose the right application for their contracted projects.

Whether or not the assistance of Smart P&IDs is used, mistakes are made in industry. One major advantage of Smart P&IDs is to reduce time spent manually accumulating Excel sheets of equipment, instruments, valves, and lines. With one less step in the design process, fewer errors are theoretically made. A future study could determine the percent error in Microsoft Excel documentation when using regular P&IDs versus Smart P&IDs. This statistic would also appeal to companies when advertising the product.

Bibliography

1. "Biodiesel Basics." *Biodiesel.org*. N.p., n.d. Web. 24 Apr. 2017.

<http://biodiesel.org/what-is-biodiesel/biodiesel-basics>

2. "CAD Software | 2D And 3D Computer-Aided Design | Autodesk." *Autodesk 2D and 3D Design and Engineering Software*. N.p., n.d. Web. 24 Apr. 2017.

<http://www.autodesk.com/solutions/cad-software>

3. Cam, Cad. "All About CAD Conversion." *What Are Intelligent P&IDs and Their Advantages?* N.p., n.d. Web. 24 Apr. 2017.

<http://info.cadcam.org/blog/what-are-intelligent-pids-and-their-advantages>

4. Cook, Robert. "Codes, Tags and Labels-Interpreting Piping and Instrumentation Diagrams." *American Institute of Chemical Engineers*. AICHE, 27 Oct. 2010. Web. 24 Apr. 2017.

<https://www.aiche.org/chenected/2010/10/codes-tags-and-labels-interpreting-piping-and-instrumentation-diagrams>

5. "Control and Field Instrumentation Documentation - Chapter 7." *The International Society of Automation*. ISA, n.d. Web. 24 Apr. 2017.

<https://www.isa.org/pdfs/news/chapter7-control-loop/>

6. Liptak, Bela G. "Process Measurement and Analysis - Chapter 1." *Universidad Del Cauca*. N.p., n.d. Web. 24 Apr. 2017.

ftp.unicauca.edu.co/Facultades/FIET/DEIC/Materias/Instrumentacion%20Industrial/Instrument_Engineers_Handbook_-_Process_Measurement_and_Analysis/Instrument%20Engineers'%20Handbook%20-%20Process%20Measurement%20and%20Analysis/1083ch1_1.pdf

7. "P&ID - Piping and Instrumentation Diagram." *The Engineering ToolBox*. N.p., n.d. Web. 24 Apr. 2017.

http://www.engineeringtoolbox.com/p-id-piping-instrumentation-diagram-d_466.html

8. "What Are Piping & Instrumentation Diagrams." *Lucidchart*. Lucid Software Inc, 20 Mar. 2017. Web. 24 Apr. 2017.

<https://www.lucidchart.com/pages/p-and-id>

9. "Smart P&ID Questionnaire." Interview by Alexander Gikas and Anthony Kassas. *Michael Hanson*. DPS Engineering, 15 Mar. 2017.

10. "Smart P&ID Questionnaire." Interview by Alexander Gikas and Anthony Kassas. *Stan Jih Vanderweil*, 18 Apr. 2017.

11. "Smart P&ID Questionnaire." Interview by Alexander Gikas and Anthony Kassas. *Tim Foley*. DPS Engineering, 07 Feb. 2017.

12. "SmartPlant® Enterprise." *Intergraph News*. Intergraph Corporation Part of Hexagon, n.d. Web. 24 Apr. 2017.

<http://www.intergraph.com/products/ppm/smartplant/>

13. "What Is Computer-aided Design or CAD? Definition and Meaning." *Market Business News*. N.p., 01 Feb. 2017. Web. 24 Apr. 2017.

<http://marketbusinessnews.com/financial-glossary/computer-aided-design-cad-definition-meaning/>

Appendices

Appendix A: Smart P&ID Revisions

PFD

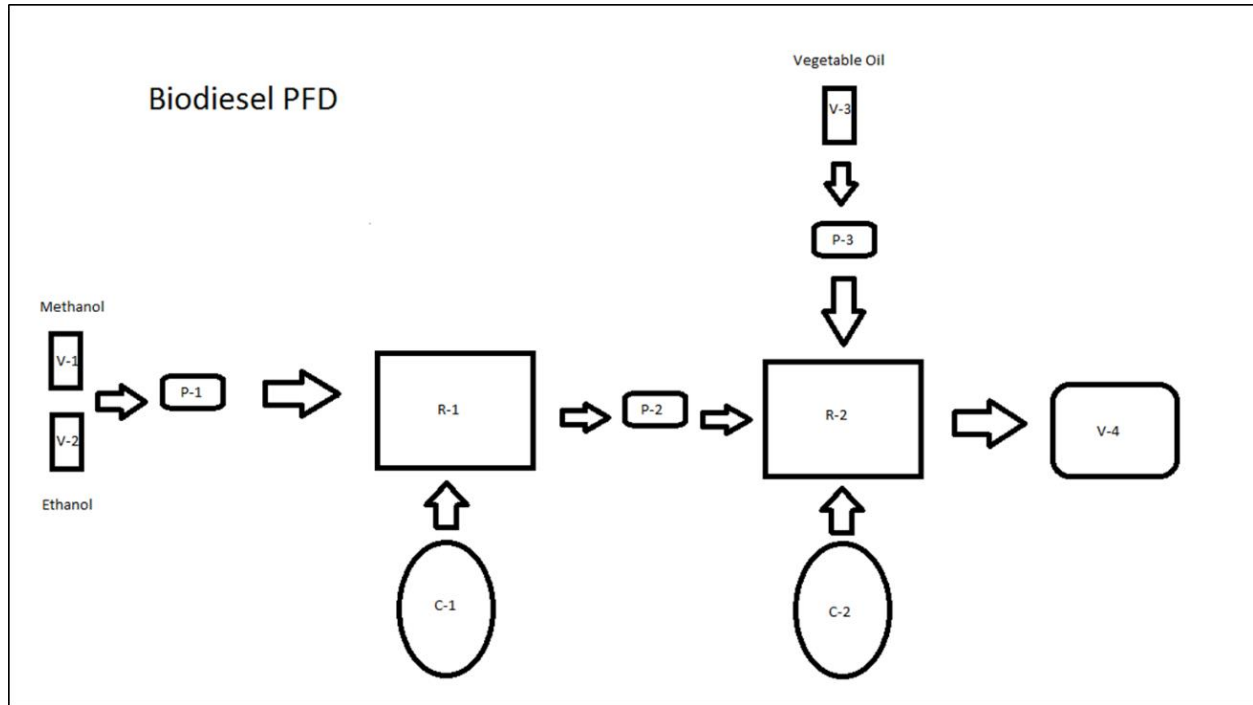

Figure 7: Process Flow Diagram

Original P&ID drawing

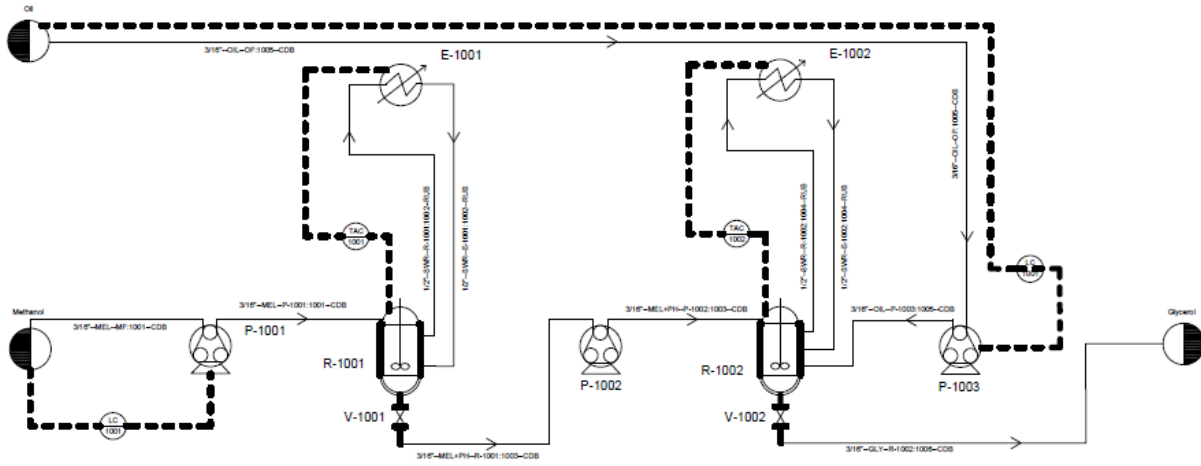

Figure 8: P&ID

Revision A Smart P&ID Drawing

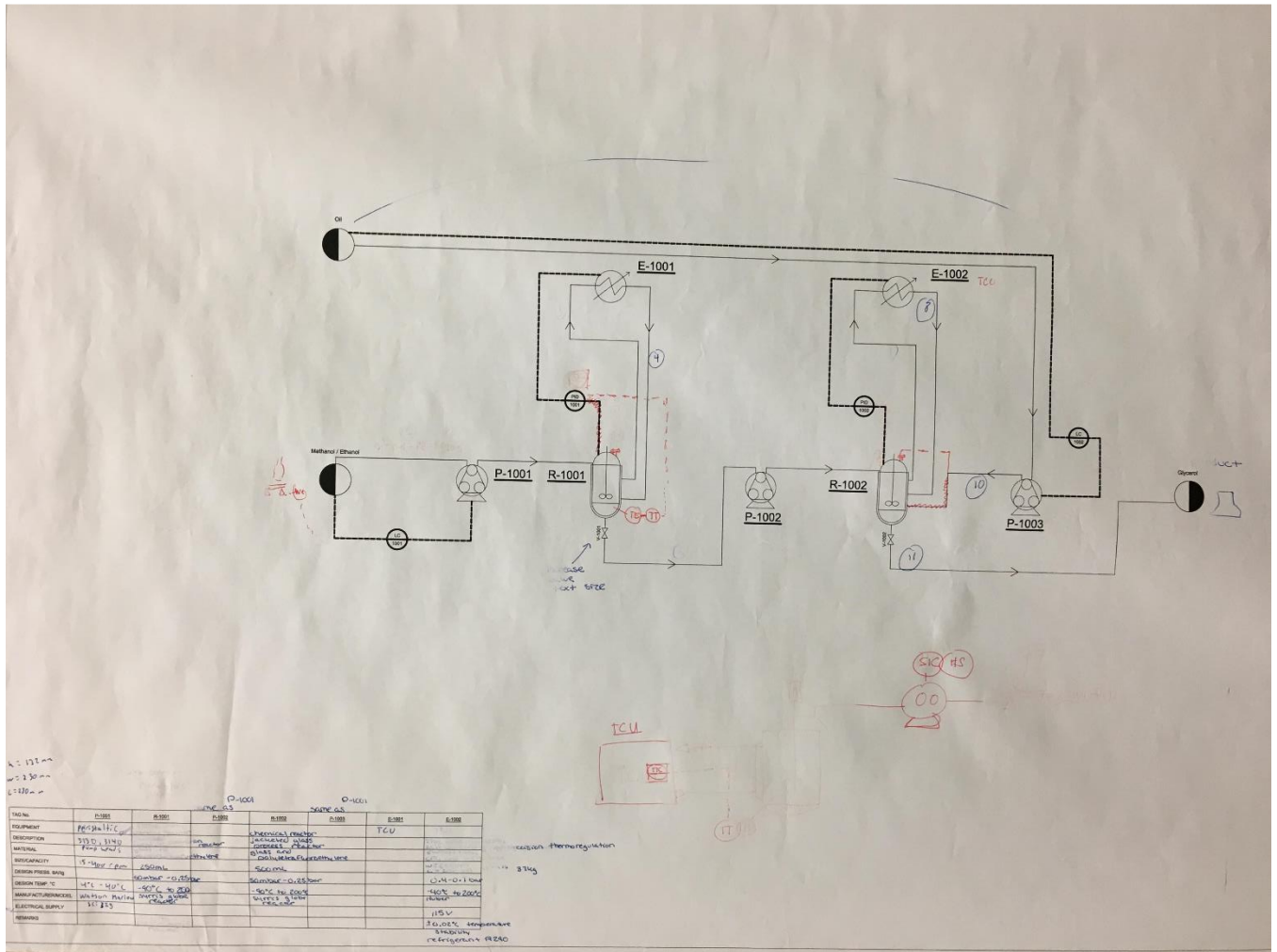
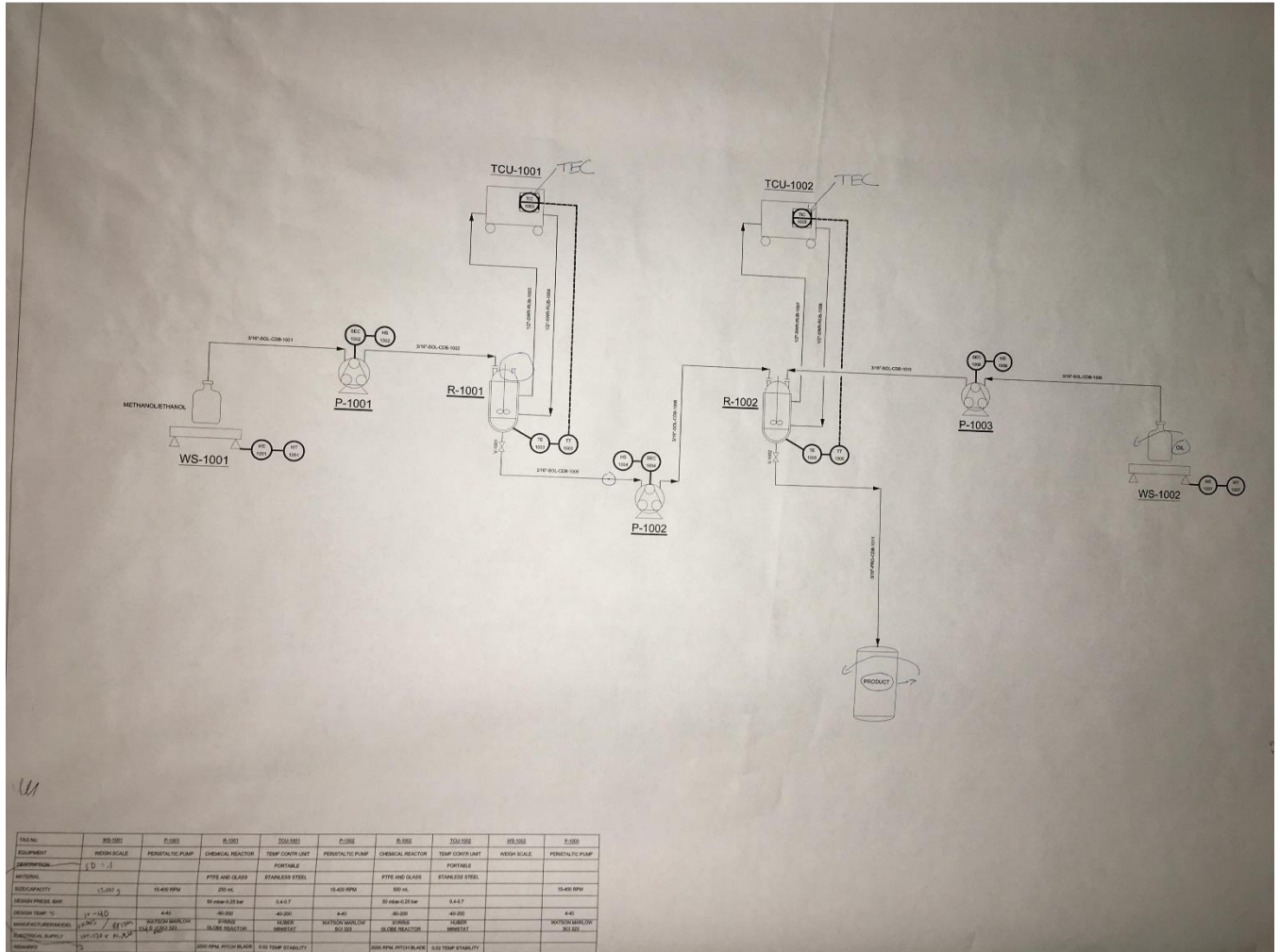

Figure 9: Smart P&ID Revision A

Revision B Smart P&ID Drawing



TAG NO.	WS-1001	P-1001	R-1001	TCU-1001	P-1002	R-1002	TCU-1002	P-1003	WS-1002	P-1003
EQUIPMENT	WEIGH SCALE	PERISTALTIC PUMP	CHEMICAL REACTOR	TEMP CONTROL UNIT	PERISTALTIC PUMP	CHEMICAL REACTOR	TEMP CONTROL UNIT	WEIGH SCALE	PERISTALTIC PUMP	PERISTALTIC PUMP
DESCRIPTION	1000 g		PORTABLE			PORTABLE				
MATERIAL		PTFE AND GLASS	STAINLESS STEEL		PTFE AND GLASS	STAINLESS STEEL				
CAPACITY	1.000 g	15.400 RPM	200 mL	15.400 RPM	300 mL	15.400 RPM				15.400 RPM
DESIGN PRESS. BAR		4.41	BY REAR 0.25 BAR	0.45.7	BY REAR 0.25 BAR	0.45.7				
DESIGN TEMP. °C		4.41	40.000	0.41	40.000	40.000				4.41
MATERIAL PERFORMANCE	100% PTFE / 100% PTFE	100% PTFE / 100% PTFE	100% PTFE / 100% PTFE	100% PTFE / 100% PTFE	100% PTFE / 100% PTFE	100% PTFE / 100% PTFE	100% PTFE / 100% PTFE	100% PTFE / 100% PTFE	100% PTFE / 100% PTFE	100% PTFE / 100% PTFE
ELECTRICAL SUPPLY	100V 1.5A 50/60 Hz	100V 1.5A 50/60 Hz	100V 1.5A 50/60 Hz	100V 1.5A 50/60 Hz	100V 1.5A 50/60 Hz	100V 1.5A 50/60 Hz	100V 1.5A 50/60 Hz	100V 1.5A 50/60 Hz	100V 1.5A 50/60 Hz	100V 1.5A 50/60 Hz
REMARKS		1000 RPM PITCH BLADE	1000 RPM PITCH BLADE	1000 RPM PITCH BLADE	1000 RPM PITCH BLADE	1000 RPM PITCH BLADE	1000 RPM PITCH BLADE	1000 RPM PITCH BLADE	1000 RPM PITCH BLADE	1000 RPM PITCH BLADE

Figure 10: Smart P&ID Revision B

Revision C Smart P&ID Drawing

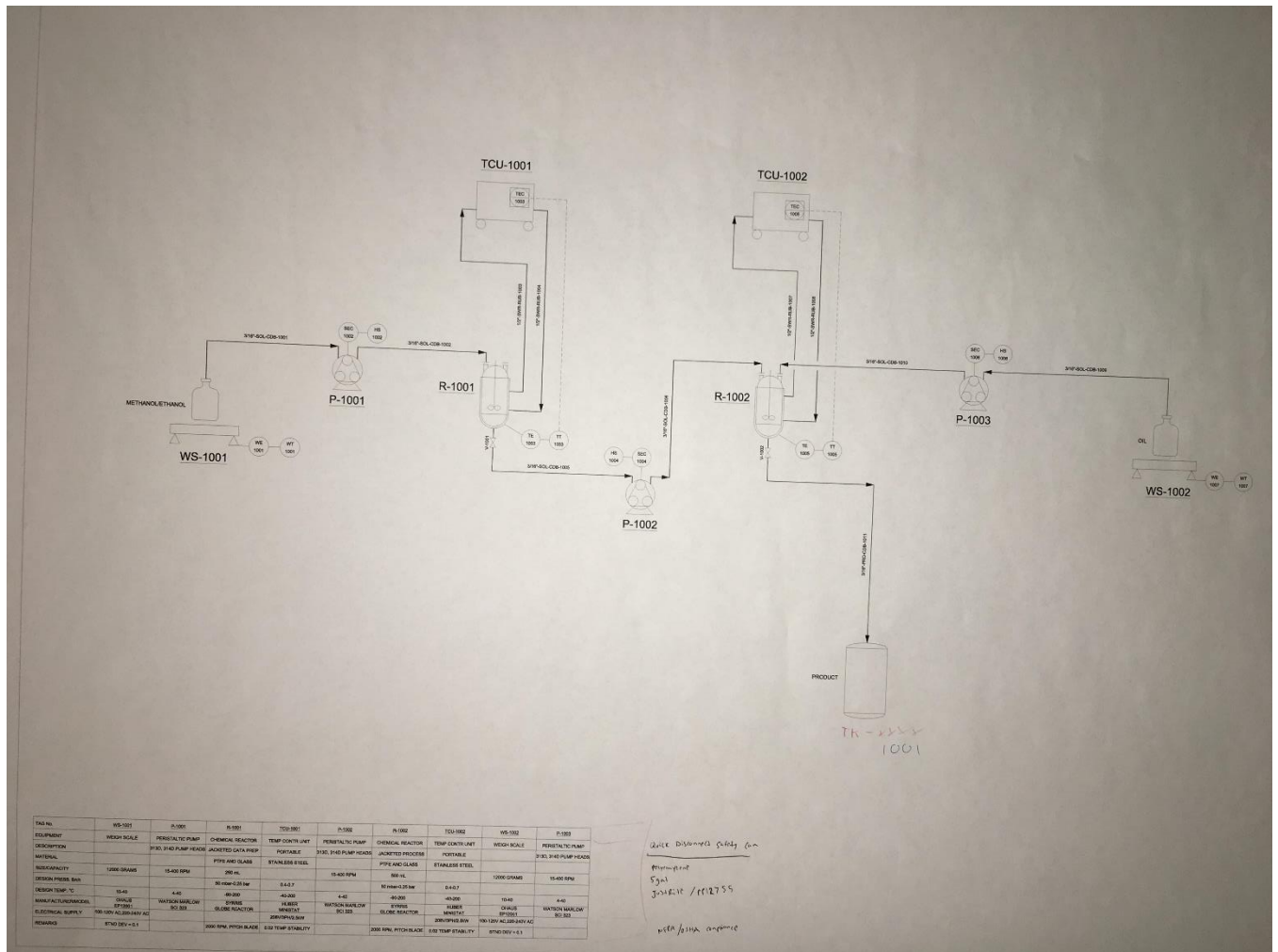



Figure 11: Smart P&ID Revision C

Appendix B: Equipment List – Database Quantities



IDENTIFICATION				INFORMATION		
ID	Tag No.	P&ID No.	Location	Room No.	Equipment Type	Manufacturer
3200026	P-1001	ALEXANTHON	GH Unit Ops Lab	1	PERISTALTIC PUMP	WATSON MAR
3200089	P-1002	ALEXANTHON	GH Unit Ops Lab	1	PERISTALTIC PUMP	WATSON MAR
3200093	P-1003	ALEXANTHON	GH Unit Ops Lab	1	PERISTALTIC PUMP	WATSON MAR
3200021	R-1001	ALEXANTHON	GH Unit Ops Lab	1	CHEMICAL REACTOR	SYRRIS
3200090	R-1002	ALEXANTHON	GH Unit Ops Lab	1	CHEMICAL REACTOR	SYRRIS
3200062	TCU-1001	ALEXANTHON	GH Unit Ops Lab	1	TEMP CONTR UNIT	HUBER
3200091	TCU-1002	ALEXANTHON	GH Unit Ops Lab	1	TEMP CONTR UNIT	HUBER
3200118	TK-1001	ALEXANTHON	GH Unit Ops Lab	1	QUICK DISCONNECT CAN	JUSTRITE
3200104	WS-1001	ALEXANTHON	GH Unit Ops Lab	1	WEIGH SCALE	OHAUS
3200103	WS-1002	ALEXANTHON	GH Unit Ops Lab	1	WEIGH SCALE	OHAUS

Figure 12: Database Equipment List, Part 1

Equipment List						
PHYSICAL DATA						
Model No.	Material	W	D	H	SIZE/ CAPACITY	WEIGHT
SCI 323		230 mm	230 mm	132 mm	15-400 RPM	4.5 kg
SCI 323		230 mm	230 mm	132 mm	15-400 RPM	4.5 kg
SCI 323		230 mm	230 mm	132 mm	15-400 RPM	4.5 kg
GLOBE REACTOR	PTFE AND GLASS				250 mL	
GLOBE REACTOR	PTFE AND GLASS				500 mL	
MINISTAT 230	STAINLESS STEEL	255 mm	450 mm	476 mm	3.2 L	37 kg
MINISTAT 230	STAINLESS STEEL	255 mm	450 mm	476 mm	3.2 L	37 kg
PP12755	POLYETHYLENE			508 mm	5 GAL	
EP12001		360 mm	445 mm	140 mm	12000 GRAMS	12.3 kg
EP12001		360 mm	445 mm	140 mm	12000 GRAMS	12.3 kg

Figure 11: Database Equipment List, Part 2

DESIGN DATA		ELECTRICAL	REMARKS
Pressure	Temp (°C)	V/ P/ A	
313D, 314D PUMP HEADS	4-40	~100-120V/~220-240V	313D, 314D PUMP HEADS
313D, 314D PUMP HEADS	4-40	~100-120V/~220-240V	313D, 314D PUMP HEADS
313D, 314D PUMP HEADS	4-40	~100-120V/~220-240V	313D, 314D PUMP HEADS
50 mbar-0.25 bar	-90-200		JACKETED CATA PREP, 2000 RPM, PITCH BLADE
50 mbar-0.25 bar	-90-200		JACKETED PROCESS, 2000 RPM, PITCH BLADE
0.4-0.7	-40-200	115 V	0.02 TEMP STABILITY
0.4-0.7	-40-200	115 V	0.02 TEMP STABILITY
			MFPH/OSHA COMPLIANCE
	10-40	~100-120V/~220-240V	STANDARD DEVIATION = 0.1 GRAMS
	10-40	~100-120V/~220-240V	STANDARD DEVIATION = 0.1 GRAMS

Figure 12: Database Equipment List, Part 3

Appendix C: Instrument List – Database Quantities

DPS					
TAG		DETAILS		PID/ EQUIPMENT	
ID	Function	Tag No.	Instrument Type	P&ID	Equip. No.
3200080	HS	1002	Hand Switch	ALEXANTHONYW	P-1001
3200082	HS	1006	Hand Switch	ALEXANTHONYW	P-1003
3200085	HS	1004	Hand Switch	ALEXANTHONYW	P-1002
3200083	SEC	1004	Speed Element Control	ALEXANTHONYW	P-1002
3200081	SEC	1006	Speed Element Control	ALEXANTHONYW	P-1003
3200079	SEC	1002	Speed Element Control	ALEXANTHONYW	P-1001
3200066	TE	1005	Temperature Element	ALEXANTHONYW	R-1002
3200063	TE	1003	Temperature Element	ALEXANTHONYW	R-1001
3200068	TEC	1005	Temperature Element Control	ALEXANTHONYW	TCU-1002
3200065	TEC	1003	Temperature Element Control	ALEXANTHONYW	TCU-1001
3200067	TT	1005	Temperature Transmitter	ALEXANTHONYW	R-1002
3200064	TT	1003	Temperature Transmitter	ALEXANTHONYW	R-1001
3200077	WE	1001	Weight Element	ALEXANTHONYW	WS-1001
3200086	WE	1007	Weight Element	ALEXANTHONYW	WS-1002
3200087	WT	1007	Weight Transmitter	ALEXANTHONYW	WS-1002
3200078	WT	1001	Weight Transmitter	ALEXANTHONYW	WS-1001

Figure 13: Database Instrument List

Appendix D: Line List – Database Quantities



ID	P&ID	LINE SIZE	PIPING SPECIFICATION	FLUID SERVICE
3200005	ALEXANTHONYWPI.DWG	1/2"	RUBBER	SEWER
3200006	ALEXANTHONYWPI.DWG	1/2"	RUBBER	SEWER
3200013	ALEXANTHONYWPI.DWG	1/2"	RUBBER	SEWER
3200045	ALEXANTHONYWPI.DWG	1/2"	RUBBER	SEWER
3200055	ALEXANTHONYWPI.DWG	3/16"	CHEM-DURANCE BIO	PRODUCT
3200071	ALEXANTHONYWPI.DWG	3/16"	CHEM-DURANCE BIO	SOLVENT
3200072	ALEXANTHONYWPI.DWG	3/16"	CHEM-DURANCE BIO	SOLVENT
3200009	ALEXANTHONYWPI.DWG	3/16"	CHEM-DURANCE BIO	SOLVENT
3200076	ALEXANTHONYWPI.DWG	3/16"	CHEM-DURANCE BIO	SOLVENT
3200075	ALEXANTHONYWPI.DWG	3/16"	CHEM-DURANCE BIO	SOLVENT
3200074	ALEXANTHONYWPI.DWG	3/16"	CHEM-DURANCE BIO	SOLVENT

Figure 14: Database Line List, Part One

Line List			
LINE NUMBER	From	To	FLUID STATE (G/L)
1003	R-1001	TCU-1001	L
1004	TCU-1001	R-1001	L
1007	R-1002	TCU-1002	L
1008	TCU-1002	R-1002	L
1011	R-1002	TK-1001	L
1001	WS-1001	P-1001	L
1002	P-1001	R-1001	L
1005	R-1001	P-1002	L
1006	P-1002	R-1002	L
1009	WS-1002	P-1003	L
1010	P-1003	R-1002	L

Figure 15: Database Line List, Part 2

Appendix E: Professional Interviews

Interviewee: Michael Hanson, Engineering Principal at DPS Engineering

1. Do you find CADWorx software to be beneficial in terms of efficiency as opposed to AutoCAD P&ID development without CADWorx?

In general, yes. Being our first project utilizing the Smart P&ID we did have some struggles initially as we figured out the nuances. But once the CAD operators got familiar with the software efficiency improved. Efficiency will further improve when Engineers begin uploading their data via the database program as opposed to the CAD operators typing information in manually.

2. What are some pros and cons of using Smart P&IDs?

Cons: There is a lot of up front work required to set-up the databases and build the P&ID's. Like all software there are bugs and work-arounds required to get things to look/act just the way you want it. Efficiency and benefits decrease with project size/scope. If data is wrong in the database, it is wrong in both the drawings and reports

Pro: Efficiency and benefits increase with project size/scope. Data can be downloaded and uploaded to project database. List/reports can be automatically generated (downloaded) from the database. Data can be manipulated in Excel and re-uploaded to the database. Quality is improved in that there is consistency between the drawings and lists as the data contained in each are pulled from the same database.

3. Does the infrastructure of the CADWorx software provide the ability to scale-up processes?

Scale-up would require manual manipulation of the data. This can be done easily in Excel (i.e. increase size of line and equipment) then upload the scaled-up parameters to the database.

4. Does CADWorx better apply in some situations of P&ID development over just using AutoCAD, and vice versa?

I think CADWorx is best applied to projects done on newly generated P&ID's. Some of our projects require us manipulated client drawings and returning the updated drawings to them. Depending on the size and scope of a project, it may be more efficient to pre-form the work in AutoCAD. Otherwise, the smart object based on the client's symbols will need to be generated and the CADWorx file will need to be converted back to AutoCAD format when returning them to the client.

Interviewee: Stan Jih, Engineering Principal at Vanderweil

1. Do you find Smart P&ID software to be beneficial in terms of efficiency as opposed to P&ID development without Smart P&IDs?

Smart P&ID's offer efficiencies to both the design engineer and owner. The efficiencies for the design engineer include have the data sheets and cut sheets of the devices in lieu of having to produce them each time you develop P&ID's. Also, the development of points list for the controls vendor (on larger projects). Typically, the controls vendor will offer PLC control and develop their own points list which may or may not be exactly what the engineer or owner requires. Once the project is complete the owner can also use the documents in similar manner when making changes to their process.

2. What are some pros and cons of using Smart P&IDs?

Pros:

- Minimizes risks for the engineer and allows for consistency which is also a benefit for the client.
- Saves time for the engineer by not having to develop data sheets and specs for each device.
- Allows for devices to change for all projects if the engineer prefers one over another (global change).

Cons:

- Can be cumbersome to use until you get used to it.
- Can make the engineer complacent by not customizing each design
- It's easy to make the same mistake over and over until the error is identified.
- Allows the controls vendor the ability to only provide what's shown and not necessarily what's in the specifications.

3. Does the infrastructure of the Smart P&ID software provide the ability to scale-up processes?

Not exactly, but once design engineers get used to using smart p&ids, it's very intuitive and can be efficient at both small and large scale processes.

4. Does Smart P&ID better apply in some situations of P&ID development over just using AutoCAD, and vice versa?

Smart P&ID's use AutoCAD. The attribute blocks (which are the tags pointing to the devices shown on the drawings) are linked back to a data base which are linked back to spreadsheets, and cut sheets.

Interviewee: Tim Foley – CAD Operator at DPS Engineering

1. Do you find CADWorx software to be beneficial in terms of efficiency as opposed to AutoCAD P&ID development without CADWorx?

Compared to AutoCAD it takes a lot longer due to not being able to copy drawings or sections of drawings.

2. What are some pros and cons of using Smart P&IDs?

Pros – Standardized symbols that automatically break lines. Automatically creates Line, Valve, Equipment and Instrument lists.

Cons – Not being able to copy drawings and sections of drawings (need to be re-drawn).

Database items need to be carefully looked at due to hidden attributes within drawings. There are many glitches that need to be worked out.

3. Does the infrastructure of the CADWorx software provide the ability to scale-up processes?

- You can upgrade to a new phase or revision easily.
- You can convert a regular P&ID to a Smart P&ID with a lot of work.
- You can upgrade the software by creating new symbols but this can be tricky.
- You can add new portions of a P&ID very easily.

4. Does CADWorx better apply in some situations of P&ID development over just using AutoCAD, and vice versa?

- For larger scaled projects it helps the engineer to work with a database to create and work with Line, Valve, Equipment and Instrument lists.
- For smaller jobs maybe best to use AutoCAD without a database.