

March 2010

# Development of A Sustainable Landscape Architecture Best Practices Manual

Angel Luis Munoz  
*Worcester Polytechnic Institute*

James Charles Hogan  
*Worcester Polytechnic Institute*

Peter Dominic Cacciatore  
*Worcester Polytechnic Institute*

Rebecca M. Mattern  
*Worcester Polytechnic Institute*

Follow this and additional works at: <https://digitalcommons.wpi.edu/mqp-all>

---

## Repository Citation

Munoz, A. L., Hogan, J. C., Cacciatore, P. D., & Mattern, R. M. (2010). *Development of A Sustainable Landscape Architecture Best Practices Manual*. Retrieved from <https://digitalcommons.wpi.edu/mqp-all/2323>

This Unrestricted is brought to you for free and open access by the Major Qualifying Projects at Digital WPI. It has been accepted for inclusion in Major Qualifying Projects (All Years) by an authorized administrator of Digital WPI. For more information, please contact [digitalwpi@wpi.edu](mailto:digitalwpi@wpi.edu).



# Development of A Sustainable Landscape Architecture Best Practices Manual

A Major Qualifying Project for Stantec Consulting Ltd.  
submitted to the Faculty of  
WORCESTER POLYTECHNIC INSTITUTE  
in partial fulfillment of the requirements for the Degree of Bachelor of Science

Submitted by:

Peter Cacciatore

---

James Hogan

---

Rebecca Mattern

---

Angel Munoz

---

Project Advisors: Fred Hart and Suzanne LePage  
Project Sponsor: Klaas Rodenburg

March 4<sup>th</sup>, 2010

## **Abstract**

The goal of this project was to develop a Best Practices Manual (BPM) for Stantec Inc regarding sustainable landscape architecture practices. The manual will be used by Stantec employees to help assess the feasibility of landscape architecture practices for specific projects. Potential Benefits, Potential Risks and Considerations, Estimated Costs, Recommended Site Characteristics, and Potential LEED Credits were researched and presented for each practice within the BPM. This information was then posted on an internal electronic best practices manual so that all employees within Stantec could access the information.

## **Acknowledgements**

The team would like to thank the following people for their assistance over the course of this project:

Klaas Rodenburg (Sustainable Design Coordinator)

Fred Hart (WPI, Professor)

Suzanne LePage (WPI, Adjunct Professor)

Brian Stephenson (Manager, Corporate Real Estate)

Christa Maiorana (Human Resources)

Shawn Paulson (Director, Learning)

## Executive Summary

Stantec is a thriving engineering firm based out of Edmonton, Alberta, which has recently been established as one of the top 10 design firms in the world. Today the company has over 10,000 employees that concentrate on environmental, industrial, transportation, urban land, buildings, and sustainable engineering. With a company the size of Stantec, Best Practices Manuals (BPMs) are often an efficient means to transfer engineering knowledge between employees.

A BPM includes information regarding a practice that is meant to serve as a reference for those unfamiliar with the practice. They are useful for large companies because they reduce the need for employees to ask other employees for information that can be cataloged and placed in one manual. By providing this information in a single location, the employee seeking the information can access it faster without interrupting other employees who may or may not know the desired information. Therefore, the introduction of BPMs can increase productivity of organizations such as Stantec.

Sustainable engineering is one of the subdivisions within Stantec and is the focus of this report. Within sustainable engineering, this report primarily focuses on sustainable landscaping architecture practices and the incorporation of a BPM for Stantec. Landscape architecture encompasses urban design, community and regional planning, interior and exterior garden design, parks and recreation, historic site and natural area preservation, energy and water conservation, landscape restoration and management, among others (Answers Corporation, 2010). Within this broad field the following practices were considered and analyzed:

- Green roofs
- Green walls
- Permeable pavements
- Stormwater runoff infiltration

- Constructed wetlands
- Rainwater harvesting
- Xeriscaping

In addition the practices of district energy and air handler condensate recovery systems were incorporated into the BPM produced. The entire BPM can be seen in Appendix A: Best Practices Manual.

District energy and air handler condensate recovery systems were considered because a large amount of useful information was collected regarding them during the completion of a subproject. The subproject was a report on sustainable strategy options for the city of Kingston, Jamaica. This report was compiled during the beginning phases of the BPM project and helped to help establish a uniform format for the finished BPM. The Kingston report can be seen in Appendix B: Report Compiled for Jamaica Project. In addition to the Kingston subproject, the team also assisted in the preparation and execution of a design charrette for the Clareview Recreation expansion in Edmonton, Alberta, Canada.

For the charrette, the team compiled a report on potentially useful sustainable strategies from the sustainable landscape practices BPM and other sources. This report can be seen in Appendix C: Recreation Center Charette Preparation. It provided the team with an opportunity to test the usefulness of the BPM and was helpful in determining the overall structure of the manual.

The project team also used the Clareview Recreation as the basis of a case study on how the BPM would be applied to real projects. This would serve as the basis of the capstone design project. The capstone design project consisted of applying the BPM to a simplified recreation center to examine the feasibility of installing a green roof on the facility. More details on the capstone design project can be seen below in the Capstone Design section.

The results of this project include the Landscape Architecture BPM, its incorporation into the eBPM, and a capstone design. The Landscape Architecture BPM was designed as a tool to help Stantec employees select from a varied list of sustainable technologies during the preliminary stages of a project.

The main sections of the BPM were potential benefits, potential risks and considerations, costs, and recommended site characteristics. These were chosen to represent the most common areas Stantec employees need when interacting with clients interested in implementing sustainable practices. Therefore, the BPM provides a timely method for conducting initial research, which allows additional time to explore alternatives or more in-depth design considerations. Once the BPM was completed, it was posted onto an internal electronic Best Practices Manual (eBPM) within Stantec.

Stantec has an internal eBPM for the transfer of information between its employees. This eBPM is referred to as a “living document” because of the ability of individual employees to add information to the eBPM through the posting of new sections. It was to this document that the individual sections of the BPM produced were added.

On the eBPM the sections for green roofs, green walls, permeable pavements, stormwater runoff infiltration, constructed wetlands, rainwater harvesting, xeriscaping, and air handler condensate recovery systems were added under the subtopic of “Water Management Strategies” within “Resource Management” and the district energy section of the BPM was added in the “Resource Management” section directly. This was done because all the practices considered in the BPM were related to water conservation except district energy.

The capstone design project assessed the applicability of three different green roof designs to the proposed recreation center which was presented at the design charrette. The options were an extensive green roof on both the new and existing structures, an intensive roof on both structures, and an intensive roof on the new structure with an extensive roof on the existing. These options were assessed in terms of impact on air quality, thermal performance, impact on stormwater runoff, installation and maintenance costs, and structural requirements. In the end, it was determined that the best option was to apply an extensive green roof design to both the proposed expansion and the existing building.

## **Capstone Design**

In accordance with the Accreditation Board of Engineering and Technology (ABET) a capstone design project was incorporated into this report. This capstone design project consisted of analyzing the feasibility of installing a green roof on a recreation center in Edmonton, Alberta. This analysis included a comparison of the benefits and costs of installing either an extensive or intensive green roof on an existing building or a proposed expansion. To fulfill the ABET requirement, six of the eight fields of consideration were examined during this analysis. The six considerations were Economic, Environmental, Sustainability, Manufacturability, Health and Safety, and Social.

### **Economic Considerations**

A detailed cost analysis was performed in this design problem in order to determine the economic feasibility of the different design variations presented. The factors that were considered include: the cost of manufacture and installation, the cost of structural upgrades to the building required for the design, the change in maintenance costs with the different designs compared to a normal roof, and the savings associated with a reduction in stormwater runoff and a reduction in electricity and natural gas used to heat and cool the building. All of these factors represented a change in the economic consideration of the design, and the final conclusion is partially based on these factors.



## **Environmental Considerations**

The installation of a green roof can have significant environmental impact on the surrounding area. In this case three different factors were considered. The first is that the presence of greenery can reduce the amount of pollution and particulate matter in the air. The second is that the plants and soil on a green roof absorb stormwater and can reduce the flow of runoff into the wastewater system. The third is that reducing energy usage will result in fewer emissions from power production, since power generation in Edmonton uses coal powered plants. Due to this fact energy reduction was considered both an environmental benefit and a sustainable benefit.

## **Sustainability Considerations**

Green roofs generally have a very positive impact on the sustainable operation of a building. In this case several factors contributed to the sustainability of the project. Reduced energy demand for heating and cooling is sustainable since it moves the building towards the eventual “Net-Zero” goal for power usage. The reduction in stormwater runoff contributes to sustainability because it can help mitigate the need for larger wastewater treatment facilities as cities grow in size. The reduction in maintenance on a green roof along with its longer life span contributes to sustainable goals because having longer lasting products will reduce waste over time. One concern of the green roof systems designed in this analysis is that the intensive systems may require irrigation, which is not very sustainable compared to the drought resistant plants chosen for the extensive designs.

## **Manufacturability Considerations**

The design life of the roof was considered as a positive manufacturability feature, since the green roof may require different components to be used when considering that the roof will go significantly longer without replacement. Additionally, the structure of the building was a strong consideration in the choice of green roof design. It was taken into consideration the complications of upgrading the structure of the new building, and possibly replacing parts of the structure on the old building. It was concluded that the constructability of the design was dependent upon the weight of the roof, and since upgrading the structure of the existing building would be extremely expensive this would not be intelligent from a manufacturability perspective. Considered also was the fact that an increase in the structural capacity might necessitate an increase in building height, which may interfere with the plans for building enclosure and mechanical systems.

## **Health and Safety Considerations**

The main health consideration on this project was the effect that green roofs may have on local air quality. Detailed analysis was performed to quantify the amount of pollutants that could be removed from the air by the vegetation on the green roof for the particular climate and air quality status of Edmonton. Air quality can have a significant impact on human health in some instances, so improved air quality was factored into the design decision.

## **Social Considerations**

The social implications of a green roof include the Aesthetic appeal, and the public exposure to sustainable concepts. Green roofs can be very visually pleasing as

compared to a bare roof and this can significantly alter people's perception of a building. They can have a positive psychological impact if the building is able to achieve a more "natural" feel. In addition, exposing the public to green roof is a very obvious way to advertise the concept of sustainable design. Of the many sustainable options available to building designers, green roofs are one of the most obvious to an untrained observer, and can have a very positive effect on the perception of sustainable architecture.

# Table of Contents

Abstract .....	2
Acknowledgements .....	3
Executive Summary .....	4
Capstone Design.....	7
Economic Considerations .....	7
Environmental Considerations .....	8
Sustainability Considerations .....	8
Manufacturability Considerations .....	9
Health and Safety Considerations.....	9
Social Considerations .....	9
Table of Contents.....	11
Table of Figures .....	14
Table of Tables .....	16
1 Introduction .....	18
1.1 Sustainable Landscape Architecture.....	18
1.2 Stantec Inc. ....	19
1.3 Project Setting.....	20
2 Background.....	22
2.1 Landscape Architecture Practices.....	22
2.1.1 Green Roofs .....	22
2.1.2 Green Walls .....	23
2.1.3 Permeable Pavements.....	25
2.1.4 Stormwater Runoff Infiltration .....	26
2.1.5 Constructed Wetlands.....	27
2.1.6 Rainwater Harvesting.....	28
2.1.7 Xeriscaping .....	29
2.2 Non-Landscape Architecture Practices Considered.....	30
2.2.1 District Energy Systems.....	30

2.2.2	Air Handler Condensate Recovery Systems.....	31
3	Methodology .....	33
3.1	Best Practices Manual .....	33
3.1.1	Topic Identification.....	34
3.1.2	Best Practices Manual Format.....	34
3.1.3	Online Research.....	35
3.1.4	Jamaica Report Compilation.....	36
3.1.5	Recreation Center Charrette.....	37
3.1.6	Employee Interviews.....	38
3.1.7	Electronic Best Practices Manual .....	39
3.2	Development of MQP Report.....	41
3.3	Capstone Design Project .....	41
3.3.1	Design Problem Identification .....	41
3.3.2	Design Considerations.....	43
3.3.3	Design Decisions .....	50
3.4	Presentation to Stantec.....	51
4	Results and Discussion.....	52
4.1	Application of Best Practices Manual.....	52
4.1.1	Lessons Learned Applying Best Practices Manual.....	54
4.2	Capstone Design Results .....	56
4.2.1	Installation and Maintenance Costs .....	57
4.2.2	Thermal Performance .....	59
4.2.3	Stormwater Management Benefits.....	60
4.2.4	Air Quality Benefits .....	62
4.2.5	Structural Considerations.....	63
4.3	Capstone Conclusions .....	65
	Works Cited.....	67
	Green Roof Sources.....	67
	Green Walls Sources.....	68
	Permeable Pavement MQP Sources .....	68
	Stormwater Infiltration Systems Sources .....	69

Constructed Wetlands Sources .....	70
Rainwater Harvesting Sources .....	71
Xeriscaping Sources.....	71
District Energy Sources .....	72
Air Handler Condensate Recovery Sources .....	73
Capstone Sources .....	73
Appendix A: Best Practices Manual .....	76
Appendix B: Report Compiled for Jamaica Project .....	294
Appendix C: Recreation Center Charette Preparation.....	353
Appendix D: Recreation Center Charette Results .....	367
Appendix E: Stantec Employee Interview Questions .....	371
Appendix F: Capstone Design Calculations .....	401

## Table of Figures

Figure 1: The Difference Between ST, SSF, and VF Wetlands (Ghermandi, 2007).....	27
Figure 2: Example of an Air Handler Condensate Recovery System (EPA, 2009).....	32
Figure 3: Example of Webpage on eBPM .....	40
Figure 4: Site Plan of Clareview Recreation Centre Facility .....	42
Figure 5: Layout of Building Considered .....	43
Figure 6: Example of Edmonton Land Drainage Bill (EPCOR 2010).....	48
Figure 7: Extensive Green Roof Diagram.....	87
Figure 8: Extensive Green Roof on Chicago City Hall.....	89
Figure 9: Green Walls (Econoplas, 2007) .....	108
Figure 10: Living Billboard (Laumer, 2009) .....	114
Figure 11: States with Porous Pavement (Wible, 2008).....	130
Figure 12: Porous Concrete Sample (TecEco).....	132
Figure 13: Permeable vs. Impervious Asphalt (Adams, 2003) .....	133
Figure 14: Porous Asphalt System (Smart Planet, 2009).....	134
Figure 15: Permeable Concrete vs. Conventional Asphalt (NRMCA, 2009).....	139
Figure 16: Wetland Hydrology (Beuttell, 2010).....	168
Figure 17: Bioretention Hydrology (Beuttell, 2010).....	168
Figure 18: Conventional Bioretention Systems (Beuttell, 2010) .....	170
Figure 19: Dry Bioretention Design (Beuttell, 2010) .....	170
Figure 20: Dry Bioretention Design 2 (Beuttell, 2010) .....	171
Figure 21: Bioretention Example 1 (Landcare Research, 2010).....	174
Figure 22: Vegetated Swale Example (Alameda, 2006).....	178
Figure 23: Rainwater Harvesting System (Zhang, 2008).....	190
Figure 24: First Flush Device (Cross and Duncan, 2007).....	191
Figure 25: Australian Rainwater Storage Tank Prices (Cross and Duncan, 2007).....	196
Figure 26: The Difference Between ST, SSF, and VF Wetlands (Ghermandi, 2007)..	207
Figure 27: Example of SF Wetland Layout (Greenway, 2005) .....	212

Figure 28: Typical Layout of a Subsurface Flow Constructed Wetland (Yocum, 2007)	216
Figure 29: Example of a VF Wetland Layout (Brix and Arias, 2005)	220
Figure 30: Finished VF Wetland Before and After Plants Have Grown (AQUA Treatment Technologies, 2008)	221
Figure 31: Xeriscaping Example (Fuller, 2010)	236
Figure 32: Alternative Ground Cover (Cariboo Chilcotin Conservation Society, 2004)	239
Figure 33: Diagram for a standard drip irrigation system (Shock, 2006)	241
Figure 34: Cool Season Grass (American Lawns, 2010)	246
Figure 35: Transition Zone (American Lawns, 2010)	246
Figure 36: Warm Season Grass (American Lawns, 2010)	247
Figure 37 – Cornell University Lake Source Cooling System	263
Figure 38: End Use of Water in Commercial Buildings (Wilson, 2008)	283
Figure 39: Example of an Air Handler Condensate Recovery System (EPA, 2009)	285
Figure 40: Sunshine Hours in Alberta	357



## Table of Tables

Table 1 – Green Roof Systems for Proposed Design .....	56
Table 2 – Installation and Materials Cost for Each Green Roof Component .....	57
Table 3 – Added Cost of Installation for Each green Roof Design .....	58
Table 4 – Annual Green Roof Maintenance Costs .....	58
Table 5 – Energy and Money Savings for Green Roof Alternatives .....	59
Table 6: From “Comparative environmental life cycle assessment of green roofs” (Kosareo, 2006) .....	59
Table 7 – Average Monthly Temperatures of Edmonton and Pittsburg in Fahrenheit (F °) .....	60
Table 8: Stormwater Runoff Reduction .....	60
Table 9 – Monetary Savings due to Stormwater Reduction .....	62
Table 10 – Mass of Removed Pollutants by Proposed Green Roof Systems.....	62
Table 11: From “Quantifying Air Pollution Removal by Green Roofs in Chicago” (Yang, 2008).....	62
Table 12 – Structural Loading for Each Green Roof Component.....	64
Table 13 – Added Structural Costs due to Green Roof Designs .....	65
Table 14 – Costs and Benefits of Green Roof Design Options .....	66
Table 15: Types of Climbing Plants.....	112
Table 16: Porous Pavement Costs.....	144
Table 17: Bioretention Pollutant Removal Efficiency (PGC, 2007).....	166
Table 18: Bioretention Costs (PGC, 2007) .....	172
Table 19: Results of 2005 Study by Ghermandi et al .....	212
Table 20: Typical SSF Efficiencies (Vymazal, 2005).....	218
Table 21: Efficiency of VF Wetlands of Single Family Homes (Brix and Arias, 2005) .	221
Table 22: Results of a SF-VF Wetland System in Nepal (Vymazal 2005).....	223
Table 23: Results of a VF-SF Wetland System in Colecott Ireland (Vymazal, 2005) ..	223
Table 24: Condensation Collection Facility Data (SCTRWPG, 2008) .....	286
Table 25: San Antonio River Center Mall .....	338

Table 26: San Antonio HEB Grocery Distribution Center .....	339
Table 27: Houston, Texas EPA's Environmental Services Branch Laboratory.....	339
Table 28: Portland, Oregon Veterans Affairs Medical Center.....	342
Table 29: Potential Rainwater Captured.....	356

# 1 Introduction

Sustainability has recently become an important factor in the engineering world. Landscape architecture is a discipline that attempts to improve the way humans interact with the environment (Ontario Association of Landscape Architects (OALA), 2007). That interaction can be improved in various ways such as water conservation, energy conservation, or urban planning. This project focuses on practices that improve the performance of projects in these subject areas.

To help engineers at Stantec Consulting Ltd identify applicable sustainable landscape architecture practices in their planning and design work, this project compiled a Best Practices Manual (BPM) that will be posted on StanNet (Stantec's secure internal web site) in an electronic format. This BPM is intended to help Stantec engineers identify which practices are most applicable for their projects by identifying the potential benefits, potential risks, estimated costs, recommended site characteristics, and potential LEED credits associated with each practice. By making this information easily available engineers at Stantec can identify which practices to conduct further feasibility studies on and which to dismiss early in the design process.

## ***1.1 Sustainable Landscape Architecture***

According to its definition, landscape architecture encompasses urban design, community and regional planning, interior and exterior garden design, parks and recreation, historic site and natural area preservation, energy and water conservation, landscape restoration and management, among others (Answers Corporation, 2010). The varied list is an example of the dynamic essence of landscaping and provides insight into the many areas which can be improved by implementing sustainable practices.

Sustainable development practices aim to protect the quality of life of future generations. This can only be done by understanding how the natural environment operates as well as how human interactions affect it. Sustainable Landscape Architecture focuses on enhancing the holistic knowledge of the surrounding landscapes, including the complex processes which naturally occur to maintain it. Employing this knowledge within the planning phases of development should result in the reduction of negative environmental impacts due to the same. The traditional consequences of land development can be eliminated or mitigated when developers are able to foresee the consequences of their work. Many times, replicating undeveloped conditions and/or native landscapes within the overall site design will prove very useful in achieving the goals of sustainability. All of the sustainable topics covered in this report involve the application of a technology that resulted from better understanding the natural environment.

## **1.2 *Stantec Inc.***

Stantec Consulting Ltd. is a thriving engineering firm based out of Edmonton, Alberta, which has recently been established as one of the top 10 design firms in the world. The Company today has over 10,000 employees, and has been very successful, even in the current economic recession. The key to their success seems to be diversification.

The company, originally D.R. Stanley Associates, was started by Dr. Don Stanley, in 1954, with its first office in Edmonton. The company grew slowly at first, but over time the growth accelerated, as the company became larger through acquisitions and mergers. This method of acquiring promising companies in a wide variety of fields is what led the company to cover a wide range of engineering disciplines. The name of the company was changed to Stanley Associates Engineering in 1962, then Stanley Technology group in 1989, and finally to Stantec Consulting in 1998.

Throughout the years the company expanded throughout North America, and began to take on projects abroad as well, with the first one being a sewerage system for Kuala Lumpur, Malaysia in 1967. A product of the company's extreme diversity is an ability to rapidly accommodate rising trends in the market. In recent years, sustainable design has become one of the most important new topics in the design and construction industry, and Stantec has been incorporating sustainable design into their services.

### **1.3 Project Setting**

This project was primarily conducted over two seven week sessions. The first session was conducted from late October 2009 to mid December 2009 from Worcester, Massachusetts on the Worcester Polytechnic Institute campus. The second session began in mid January 2010 and finished in early March 2010 in the Stantec offices in Edmonton, Alberta, Canada.

While in Massachusetts the project team conducted weekly meetings with professors Fred Hart and Suzanne LePage (the project advisors). The team also conducted 3 conference calls and regular email correspondence with Klaas Rodenburg, the projects sponsor, who was in Edmonton. During this period of time the primary goal of the project was to define a scope of the project and begin preliminary research for the project.

Once the project team began executing the project in Edmonton weekly conference calls with professors Hart and LePage were conducted (Mr. Rodenburg typically also attended), and meetings with Mr. Rodenburg were held as needed. While in Edmonton the project team executed the proposal of constructing a best practices manual, developing this MQP report, identified and executed a capstone design project, and presented their results to Stantec. The project team also participated in side projects at the request of Mr. Rodenburg. While not directly related to the proposed scope of work, these tasks were still useful to the project. These included developing a report on potential sustainable practices that could be implemented in Kingston,

Jamaica and assisting with the preparation and record keeping for a meeting on sustainable practices that could be applied to the Clareview Recreation Centre project in Edmonton.

## **2 Background**

The practices that were analyzed during this report included both sustainable landscape architecture and non-landscape architecture practices. These practices were selected for the Best Practices Manual (BPM) because they were available from a previous report on sustainable practices in Kingston, Jamaica. For more information on how they were chosen see the methodology section of this report.

### ***2.1 Landscape Architecture Practices***

The practices within landscape architecture that were compiled for the BPM included green roofs, green walls, permeable pavements, stormwater runoff infiltration, constructed wetlands, rainwater harvesting, and xeriscaping. The following descriptions include a brief overview of how the practices work as well as the benefits that they can produce.

#### **2.1.1 Green Roofs**

Green Roofs are flat or slightly pitched roofs of buildings which have been converted to or originally designed to be a habitat for plant life. The goal of a green roof is usually to have as much of the roof covered with foliage as possible. Green roofs all consist of the same general structure to give them the ability to support plant life without damaging the structure beneath: Roof decking (metal or concrete), Insulation, Waterproof Membrane, Drainage Layer, Growing Medium / Soil, Plant Life (Banting, 2005). Depending on the performance expectations of the green roof the properties of these layers will be designed.

There are three main varieties of green roofs; extensive, intensive, and semi-intensive. Extensive refers to smaller scale green roofs which usually have thinner layers of soil and support smaller plants. Intensive roofs are the opposite, supporting large plants (even trees) with thick layers of soil. Semi-intensive green roofs are those roofs which fall in the middle of the two extremes, sharing some qualities of both.

One of the main benefits of green roofs is their thermal properties. A green roof cools the air above them, reduces the temperature of the roof, and reduces the amount of heat transferred into the building interior. These effects can significantly reduce cooling load for the building. Reducing thermal strain on the roofing material also lengthens the life of the roof as such as by 30 years. (Kosareo, 2006)

Green roofs also provide a significant benefit with respect to stormwater mitigation. In an urban area rainstorms often produce large quantities of runoff from the many impermeable surfaces in a city. Green roofs help to reduce the flow of stormwater by absorbing significant amounts of rain before they begin to produce runoff. Green roofs may also positively affect the air quality of the surrounding area. The presence of greenery in an area can reduce concentrations of ozone, carbon dioxide, and other pollutants, while providing indirect benefits such as smog reduction through heat island mitigation.

### **2.1.2 Green Walls**

Green walls are interior and exterior walls that have vegetative covering and come in a variety of designs and sizes with a wide range of practical decorative vegetation. They utilize almost any type of plant, depending on the region (Smith, 2010). Orientation, climate, sunlight, wind exposure, and maintenance regimes all influence the palette of plants suitable for any given project (Plant Connection, 2010). There are two major types of green walls. A green façade, which uses climbing plants to form a wall covering, and a living wall, which uses modular plants in a panel system.



Green walls are also known as bio-walls, vegetated walls, eco-walls, and vertical gardens (Capital Regional District, 2010).

Green façades refer to a guidance structure that provides support for vines or climbing plants to grow up the side of a wall. Most systems use wire fencing, modular trellis systems, or stainless steel cables as support systems. Different types of supports are used for different kinds of plants, and there are four main types of climbing plants; self-clinging climbers, vines-climbing plants, leaf-twining climbers & tendril climbers, and rambler & scrambling plants (Stainless Steel Solutions, “Planting Advice” 2009).

Living walls are walls, indoors and outdoors, composed of individual planting cells attached to a supporting panel system. Mounting systems for interior and exterior living walls are generally the same. The panels are usually hung on a bracket system that can attach to most surfaces and a waterproof membrane should be attached directly behind the brackets. Typically, panels are not stacked or interlocked. Instead, each panel is hung individually and can be hung next to each other to cover a wall (Plant Connection, 2010). When crops are in the planting cells, it is uncommon for the panel to be above six feet high. This allows for easier care by working in an upright standing position (Irwin, 2008).

Green walls benefit the people and surrounding environment by removing over 80% of Volatile Organic Compounds (VOCs) and other harmful toxins (Plant Connection, 2010 & Irwin, 2009 & Irwin, 2008). The walls can also assist with sound absorption and building insulation (Plant Connection, 2010). Greenery on walls provides an aesthetically pleasant environment that can have positive mental health impacts and be a useful advertising technique (Irwin, 2008 & 2009). Maintenance, aside from typical maintenance associated with most type of plants, is not a necessity in order to maintain a green wall (Plant Connection, 2010).

### 2.1.3 Permeable Pavements

Permeable pavement is essentially a porous surface which allows water to infiltrate into the soil after collecting it in an underlying stone reservoir. They can be constructed from permeable asphalt or concrete and can range from partial to full infiltration depending on soil permeability (NAHB Research Center). By replicating the water retention and detention characteristics of pre-development conditions, permeable pavements strongly mitigate the adverse effects of development on storm water run-off volume and quality (Kloss, 2006). In doing so, porous pavements help protect water supply sources from contamination and sewer systems from over-loading.

These initial benefits continue a chain of positive consequences including: alleviating flooding downstream, recharging groundwater, and reducing the heat island effect (EPA Cool Pavements, 2005). With proper installation and maintenance porous paving can infiltrate up to 80% of annual runoff volume, removing between 65% and 85% of undissolved nutrients and 95% of sediment from runoff (Dauphin County Conservation District). Due to the quick draining capacity of permeable pavements, high skid resistance, low noise, and few puddles help reduce water related driving hazards. Also, if designed properly, the deep structural support of porous asphalt pavements can result in fewer cracks and potholes than in conventional asphalt pavement (EPA, 2009).

However, higher initial costs, reduced strength, and required maintenance coupled with limited experience with permeable pavement are dissuading clients from experimenting with this sustainable technique. Despite this fact, research is being conducted on how to improve the performance of permeable pavement and as more projects rely on this for stormwater management, performance data and analysis should become more accessible.

#### **2.1.4 Stormwater Runoff Infiltration**

Stormwater run-off infiltration systems such as bioretention areas and vegetated swales are stormwater management tools promoted by Low-Impact Development. These environmentally-conscience practices aim to mitigate some of the detrimental consequences of land development, specifically those linked to impervious surface area. Increases in impervious surface area typically lead to increased run-off volume, increased run-off contamination, and decreased ground water recharge (LID, 2007). These can then create additional consequences such as erosion, and downstream flooding. The chain of negative impacts can continue as these affect the quality and stability of eco-systems, harming a variety of native vegetation and species. Stormwater run-off infiltration systems are incorporated onto sites in an attempt to reduce and ideally prevent this chain from occurring. Therefore, the main goal of stormwater infiltration systems is to reduce imperviousness and restore undeveloped conditions. By creating vegetated areas which replicate pre-development conditions the natural hydrologic cycle can be better maintained thus inhibiting a long list of potential, harmful consequences at the source (PGC, 2007).

Infiltration systems are typically shallow depressions which include a ponding area, vegetation, and a mix of mulches, sand, and soil (EPA, 2000). However, they can be designed and altered to achieve very specific project goals. Their particular designs depend greatly on several site criteria such as soil permeability and ground slope and factors such as drainage area and climate can further limit their use (PGC, 2007).

Proper maintenance is crucial to the infiltration systems' performance over time. Inadequate maintenance has been the cause of numerous unsuccessful projects which usually result in aesthetically unpleasant sites. However, properly designed and maintained infiltration systems have shown to consistently reduce run-off volume and improve run-off quality (PGC, 2007).

## 2.1.5 Constructed Wetlands

Constructed wetlands are wetlands that have been constructed for the purpose to treat wastewater. This is done by subjecting the water to wetland vegetation, soils, and the associated microbial assemblages to treat wastewater. The vegetation, soils, and microbial assemblages in the wetland will treat the wastewater through natural processes such as aerobic and anaerobic digestion (Vymazal, 2005).

There are three main types of constructed wetlands. They are surface flow (SF) wetlands (also known as free water surface wetlands), subsurface flow (SSF) wetlands, and vertical flow (VF) wetlands. The difference between these types of wetlands relates to how the wastewater flows through the system. Figure 1 illustrates the difference between SF, SSF, and VF wetlands.

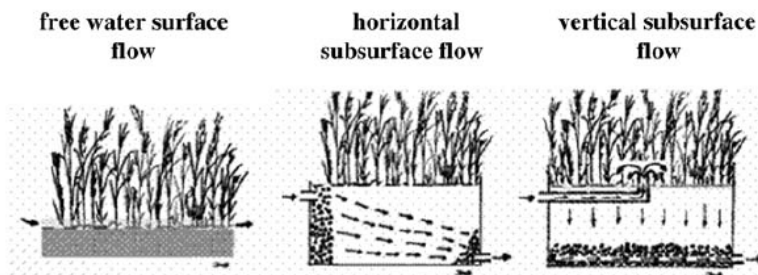

**Figure 1: The Difference Between SF, SSF, and VF Wetlands (Ghermandi, 2007)**

By using constructed wetlands to treat wastewater harmful pollutants such as pathogens, minerals, dissolved solids, heavy metals, and organic contaminants are removed from the water (Ghermandi et al, 2008). Constructed wetlands also help reduce the need for potable water, as water from a constructed wetland can be used to irrigate plants, flush toilets, or cleaning purposes (Rousseau et al, 2008). Wetlands are also said to provide social benefits by providing a place for education (for nature study) and recreational activities such as walking, jogging, hunting, and picnicking (Rousseau et al, 2008).

The biggest drawback to using constructed wetlands for wastewater treatment is securing enough land for the wetland. Therefore constructed wetlands are often used as

a low cost low energy alternative to mechanical treatment plants in rural areas where the cost of land is less (Cameron et al, 2003). Other potential drawbacks that need to be considered are the potential for wetland overflow, the potential for mosquitoes to breed in the wetland, odor control, and the negative effect of lower temperatures on the wetlands effectiveness.

### **2.1.6 Rainwater Harvesting**

Rainwater harvesting is the process of capturing rainwater and using it instead of potable water for either potable or non-potable uses. By doing this a building is able to reduce its potable water usage. The amount of potable water that is conserved using this method varies greatly depending on various characteristics such as volume and consistency of rainfall, rainwater catchment area, rainwater storage tank size, and the buildings potable water usage. These factors also dictate the cost of installing a rainwater harvesting system as well as its operating costs.

Typically rainwater harvesting systems consist of a catchment area, a treatment process, a storage tank, and piping to the intended use. For most domestic rainwater harvesting systems the catchment areas consists of the buildings roof. The treatment, size of the storage tank, and the extensiveness of the rainwater's piping system all depend on the final use of the rainwater.

After the rainwater is caught by the catchment system the water is typically filtered to prevent debris from entering the water storage tank. This help ensuring the quality of the water. The storage tank size greatly affects the economic feasibility of the system, as the cost of tank instillation tends to be the largest component of rainwater harvesting system's cost (Chilton et al, 2000). Therefore when designing a rainwater harvesting system it is very import to size the storage tank correctly.

The quality of rainwater collected also needs to be monitored if it is to be used for drinking. This is because rainwater can be contaminated with microbes, metals, or chemicals. Also, the physical qualities (such as appearance and odor) of the water must

also be taken into account. Depending on the quality of rainwater at a site and the intended use, a variety of filtration and/or disinfection methods can be used to improve the quality of rainwater.

### **2.1.7 Xeriscaping**

Xeriscaping became popular in the 1980s as a new theory for landscaping and farming during droughts. The purpose of xeriscaping is to produce fruitful vegetation and beautiful landscaping with minimal water consumption (Beaulieu, “Xeriscaping Plants” 2009).

Xeriscaping has seven chief principles that contribute to the overall goal: planning and design, soil improvement, minimizing turf, appropriate plant selection, efficient irrigation, use of mulch, and maintenance. Important aspects of xeriscaping are grouping plants with similar needs together and minimizing the amount of lawn grass. People might want a large manicured lawn, however they use a great amount of water, and xeriscaping encourages reduction of lawn areas and switching to low maintenance alternative covering. Proper planning and plant selection are also vital to reduce the amount of maintenance and water required to sustain the landscaping (Smith, 2010). In order to ensure maximum growth, suitable nutrients in the soil must be provided for the plants via mulching and irrigation. Applying these techniques encourages water conservation and improved water quality while maintaining a beautiful garden (Iannotti, “Xeriscaping Gardens” 2010).

The most beneficial results are found when all aspects of xeriscaping are applied and work together. Water consumption can be reduced up to 50% and healthier plants can result from not over or under watering (Northern Garden Supply, 2007). Xeriscaped areas are typically lower maintenance than land with traditional landscaping (Beaulieu, 2008). Xeriscaping is not only good for the environment, but they are also good for the owners by increasing the land value and heightening the curb appeal (American Lawns, 2010).

## **2.2 Non-Landscape Architecture Practices Considered**

The practices of district energy systems and air handler condensate recovery systems are the non-landscape architecture practices that were compiled for the BPM. In the following sections a brief overview of how the practices work as well as the benefits that they can produce is outlined.

### **2.2.1 District Energy Systems**

District energy usually refers to district heating and cooling, which is a system that centralizes air conditioning and heating loads for multiple buildings in one facility. District heating and district cooling can be separate systems or combined, though both work essentially the same way. A large facility will cool down or heat up a large amount of water according to the heating or cooling needs of the district. This water is then pumped through insulated pipes (usually underground) to the surrounding buildings, which will extract heat from it in the cold weather or reject heat into it in warm weather.

District cooling systems can use a wide variety of equipment and techniques to generate cool water, but there are three systems used most commonly in cooling facilities. Using a water source such as a lake or sea as a heat sink has proven to be one of the most efficient of the available means of cooling. (Chow, "Applying District Cooling", 2004) An alternative is to use absorption chillers that use heat instead of electricity to chill the water. Absorption chillers are ideal for situations where there is waste heat to be captured or where heat may be cheaper or easier to get than electric power. (Mahone, 1998) A less efficient method of district cooling is to use electricity to power chillers. These chillers are most often either traditional compression refrigerant chillers or centrifugal compression chillers.

Like district cooling there are a number of different approaches that can be used in district heating systems to heat the water for distribution to the serviced buildings. Some district heating systems include cogeneration with industrial waste heat, solid waste incineration, and coal power generation. Other common options are natural gas, solar thermal, geothermal, biofuel (including peat, wood, algae, and anaerobic digestion), as well as heating oil or kerosene. (Pöyry, 2009)

A combined system is usually a more efficient choice than having separate systems in any scenario where both heat and cooling are in relatively high demand at points throughout the year, since demand for space heating and cooling are typically offset according to the season. (Werner, 2004)

The most common goal of a district heating and/or cooling system is saving energy. All of the systems discussed above represent reduced energy consumption compared to individual systems used for space heating or cooling. The amount of energy saved is linked to the type of fuel or energy source used for the system, and the efficiency of the equipment chosen.

### **2.2.2 Air Handler Condensate Recovery Systems**

As part of the growing initiative to conserve water, unconventional methods of harvesting and reusing water are being explored. Air Handler Condensate Recovery Systems (AHCRS) are such a method. By capturing the condensate produced by the individual air handling units of a building's cooling system, free water is available to replace potable water for uses in which non-potable water would suffice (Wilson, 2008). The condensate produced is characterized by low amounts of suspended solids, a neutral to slightly acidic pH, and low temperatures; making it ideal for several uses. The most common include landscape irrigation and cooling tower make-up. An example is shown in Figure 2.



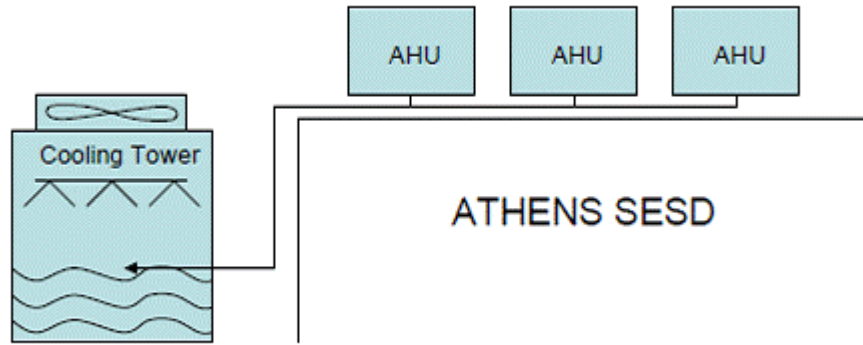

**Figure 2: Example of an Air Handler Condensate Recovery System (EPA, 2009)**

The amount of condensate produced can vary greatly and depends on the size and operational load of the cooling system and the ambient temperature and humidity within a particular region. However, a rule of thumb created by Karen Guz (director of the Conservation Department for the San Antonio Water System) is that 0.1 - 0.3 gallons of condensate per ton of air being chilled is produced every hour that the system is operating (Wilson, 2008). The efficient use of this recovered water can dramatically decrease a building's demand for potable water. By replacing or supplementing potable water with the recovered condensate for irrigation, toilet flushing, and other non-potable applications considerable environmental and economic benefits can be attained.

### **3 Methodology**

To execute this project, four central deliverables were the focus. These deliverables were a Best Practices Manual (BPM), this MQP report, a capstone design project, and a presentation to employees of Stantec on the results of this project. The following sections will outline the strategies that were employed to complete the development of each of these deliverables.

#### **3.1 *Best Practices Manual***

The Best Practices Manual (BPM) that was created consists of information on sustainable landscape architecture practices. The information that was included for each practice includes:

- A brief technical description
- A list of potential benefits
- A list of potential risks
- The estimated costs
- Recommended site characteristics
- A list of attainable LEED credits
- A list of relevant Stantec projects
- Interview data from Stantec employees

This information was compiled for green roofs, green walls, permeable pavements, bioretention basins, rainwater harvesting, constructed wetlands, and xeriscaping. Also, due to information that was collected for a side project, sections for district heat/cooling and air handler condensate recovery systems were included in the BPM as well.

To compile the BPM each of the practices covered were split among members of the team and compiled separately. The best practices manual was assembled after the

completion of all the individual sections. The sections were written so that they could be taken separately as stand-alone references. This was because the BPM was placed into an online electronic BPM (eBPM) and would therefore need to be self contained despite being linked to the other sections.

### **3.1.1 Topic Identification**

The focus of this report was chosen from an early stage to be sustainable landscape architecture practices. Within this field the topics of green roofs, urban wastewater management, grey water management, and outdoor landscaping were studied. After preliminary research was conducted urban wastewater management, grey water management, and outdoor landscaping were spilt into more specific practices. These practices were permeable pavements and bioretention basin within urban stormwater management. Within grey water management rainwater harvesting and constructed wetlands were focused on. Green walls and xeriscaping were chosen from outdoor landscaping. Once these practices were identified the process of compiling relevant information for each could begin.

### **3.1.2 Best Practices Manual Format**

The BPM's format was developed in order to ensure readability of the manual as well as a way to compare the strength and weaknesses of various practices using data presented in a consistent manor. The sections that were included in the BPM for each practice were:

- **Potential Benefits:** Benefits that could be utilized by enacting the sustainable practice are listed. These potential benefits are supported whenever possible

with examples from case studies or citations from Stantec employees with experience within the field.

- **Potential Risks and Considerations:** Any major risks to the environment, effectiveness of the systems, or social considerations associated with the practice are listed. This section includes observations from Stantec employees on design components that merited special consideration to ensure the effectiveness of the system.
- **Estimated Costs:** All cost data gathered on a practice is presented. This includes rough estimates from design professionals in the field, the costs of previous case studies, and published rules of thumb.
- **Recommended Site Characteristics:** Any site characteristics that might affect the practice are listed here. This is included to help determine whether a practice is plausible for certain sites.
- **Potential LEED Credits:** LEED credits the practice could help obtain are listed.
- **Relevant Stantec Projects:** Past Stantec projects that contain similar design aspects to the aforementioned practice are listed with a brief description. This is included to direct Stantec employees to real life examples.
- **Stantec Employee Interviews:** The responses of Stantec employees to interviews conducted via email, phone, or in person are listed here. The employees selected were chosen due to their experience in the field with the technology. As such their responses provide a useful source of information on the effectiveness and suitability of landscape architecture practices.
- **Sources:** A list of the sources and corresponding brief descriptions that are used in the BPM compile this section.

### **3.1.3 Online Research**

Each student conducted individual research on their specific topic. Preliminary research was done throughout the time allocated to the Preliminary Qualifying Project

(PQP) and resulted in an annotated bibliography (list of adequate sources with a brief description). Once in Edmonton, several textbooks were acquired from Klaas Rodenburg, however, online research was the principal source of information.

### **3.1.4 Jamaica Report Compilation**

Upon arriving in Edmonton the project team was asked to complete an additional project for Stantec. This project consisted of compiling research regarding the potential for incorporating sustainable practices to the redevelopment of downtown Kingston, Jamaica. The information included in the report was used to prepare a report for Kingston's Urban Development Corporation (UDC) by other members of Stantec. For the presentation The UDC requested information regarding the possibility of a district cooling system as well as the feasibility of renewable energy throughout the city. Therefore, the report that was compiled focused on sustainable landscape architecture topics, applying a sustainable energy BPM compiled by a previous WPI project, and researching other Kingston specific sustainable practices. The Jamaica project deliverable can be found in Appendix B: Report Compiled for Jamaica Project.

Completing the Kingston report was helpful in the completion of the BPM because multiple lessons were learned by applying the sustainable energy BPM to a specific project. Also, by creating a document meant to help a specific client the team was able to better identify practices that should be included in the BPM. Compiling the report also help the team establish a standard format for later reports.

#### **3.1.4.1 Addition of New Topics**

The topics of district energy and air handler condensate recovery systems were added to the BPM even though they are not considered sustainable landscape architecture. Information on district energy was specifically requested by the UDC for

the Kingston report and air handler condensate recovery systems were included due to the high presence of air conditioners in Jamaica. After the Kingston report was completed it was determined that the two topics were worth pursuing, as the information collected on them seemed to be useful for Stantec. They were therefore added to the BPM in a non-landscape architecture section with the understanding that once they were incorporated into Stantec's eBPM they might be separated from the landscape architecture practices.

### **3.1.5 Recreation Center Charrette**

The project team participated in a sustainable practice brainstorming charrette while in Edmonton in order to gain experience with the process of identifying preliminary potential sustainable options. The charrette was to brainstorm ideas for the Clareview Recreational Center & Branch Library. The primary role of the project team was to collect information in the architectural program relevant to sustainability, identify possible relevant practices, and take notes of the meeting. The document identifying possible sustainable practices can be seen in Appendix C: Recreation Center Charette Preparation and the notes produced after the meeting completion can be seen in Appendix D: Recreation Center Charette Results.

Participating in the Charrette helped the team identify what information was lacking within the BPM for various sections as well as gave the project team a better understanding of the process in which the BPM would most likely be used. The recreation center also served as the basis of the capstone design project (see capstone section for more details).

### 3.1.6 Employee Interviews

Members of Stantec who had experience with sustainable landscape architecture practices were contacted and asked questions about the sustainable practices under consideration. This was done in order to collect additional information not found through the online research conducted. Stantec employees were chosen by reviewing their prior experience on Stantec's employee directory.

For each sustainable landscape architecture practice a list of potential contacts was developed, and a list of questions was also developed. The questions were provided to the employees in advance of the interview via email as presented in Appendix E: Stantec Employee Interview Questions. An example is provided below:

#### *List of Questions for Green Roofs*

1. What type of experience do you have working with green roofs?
2. What cost range per square foot (or square meter) have you found to be a good estimate for green roofs versus regular roofing for any projects you worked on or know about?
3. In your opinion when is an intensive green roof worth the additional cost over an extensive green roof?
4. What are the most important factors in determining the suitability of a green roof for a particular job?
5. What types of results have you seen from green roofs (e.g. energy savings, thermal benefits, stormwater control)?
6. Are there any major disadvantages to green roofs besides cost? Has runoff water quality been an issue?
7. What are the biggest challenges in designing a green roof? What sort of structural loads might be induced by different types of green roofs?
8. Are there any lessons learned or best practices that you think would be helpful for others to be aware of when designing and building a green roof?

9. What types of advances are being made with Green Roof technology? Where do you see this technology heading in the future?
10. Do you know of any additional resources that might be helpful to me?

The information provided by each employee was placed in the BPM. For each practice in the BPM these answers can be seen in the Stantec Employee Interview section. In this section the answers each employee gave was kept anonymous and credited to “employee X” where X was a number that corresponded to the employee.

In addition to the written answers, respondents provided additional resources such as case studies or best practices manuals. These were then used complement sections of the BPM.

Some Stantec employees preferred phone interviews. For phone interviews, the Stantec employee was able to review the most current version of the applicable section of the BPM prior to the interview. In some cases, this resulted in the exchange of additional documents from Stantec employees to the student with the purpose of providing clarity during the interview. Notes were taken on the employee’s input regarding the current section, the documents exchanged as well as the information communicated throughout the actual phone conversation. The applicable information was incorporated into the BPM which provided experienced-based evidence to support the research conducted beforehand.

### **3.1.7 Electronic Best Practices Manual**

Once the BPM was completed, it was posted to the electronic Best Practices Manual (eBPM) available on Stantec’s internal network. This was done by creating a webpage for each sustainable practice that was studied. The webpage’s were created using html coding and an example of a webpage can be seen in Figure 3. These webpage’s were then added, where appropriate, within the existing framework of the eBPM.



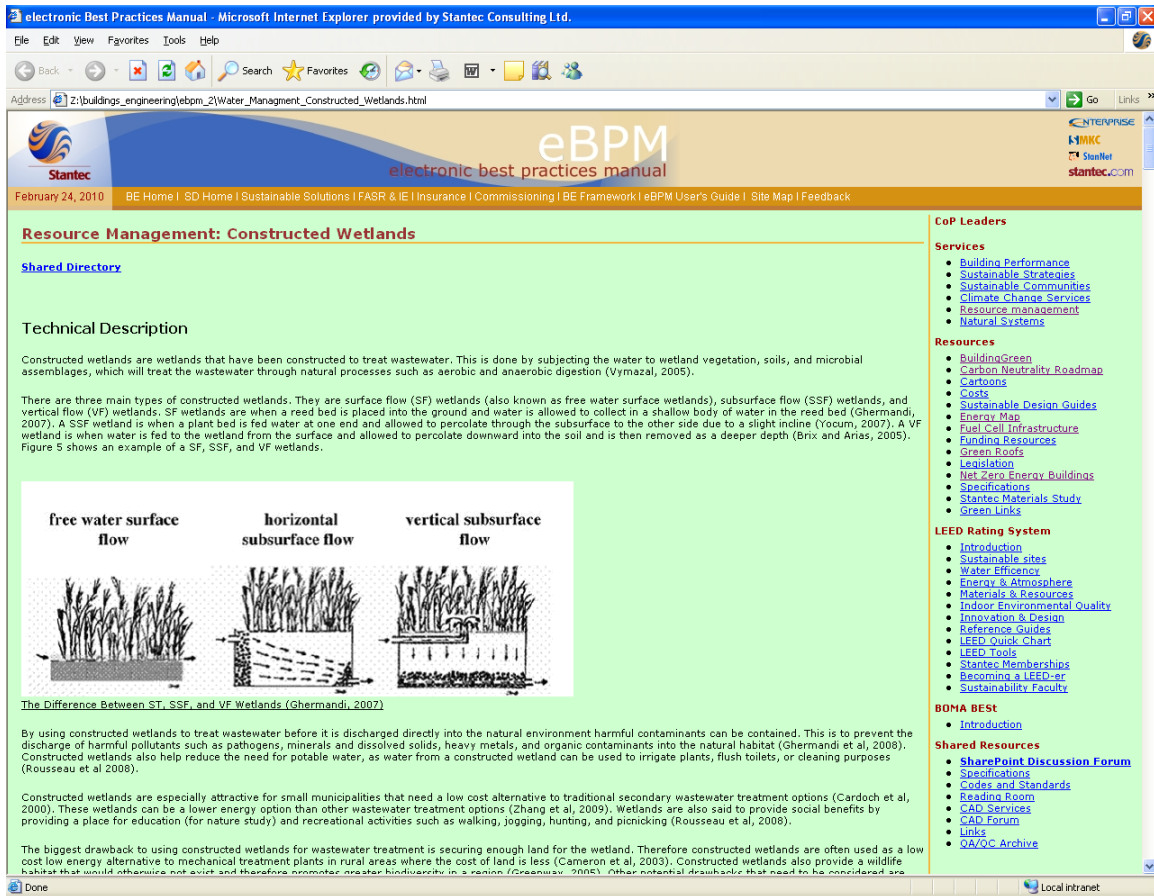

Figure 3: Example of Webpage on eBPM

The eBPM is used by Stantec employees to familiarize themselves with the basics of the sustainable practices studied. The eBPM was also created with the intent of being easily editable so that Stantec employees who have expert knowledge can post new material that may be helpful to others. The names of Stantec employees who have experience with these practices are also posted so that if a Stantec employee has a question about a sustainable practice they can obtain the contact information of knowledgeable people easily.

### ***3.2 Development of MQP Report***

The MQP report was developed by creating an outline of the report early in the project and then filling sections as the project progressed. As the project progressed and more information became available the MQP outline was written section by section. Each section was assigned to a group member, and reviewed by other members of the team to ensure consistency within the document.

### ***3.3 Capstone Design Project***

The capstone design component of this report consists of analyzing the instillation of a green roof on a building located on the Clareview Recreational Center & Branch Library site. During the course of the capstone design a building consisting of an existing structure and a proposed expansion were analyzed to determine the feasibility of installing a green roof. The installation of both extensive and intensive green roofs were analyzed. To determine the most attractive option the proposed green roofs thermal benefits, stormwater management benefits, estimated improvements to the surrounding air quality, structural considerations, and installation costs were considered.

#### **3.3.1 Design Problem Identification**

The building under consideration for the purposes of the capstone design process is located at the Clareview Recreational Center & Branch Library site in Edmonton, Alberta. The layout of the site is shown in Figure 4 in a picture provided to Stantec from the architect in a presentation on the project at a charrette meeting to identify potential sustainable practices that could be implemented at the site.

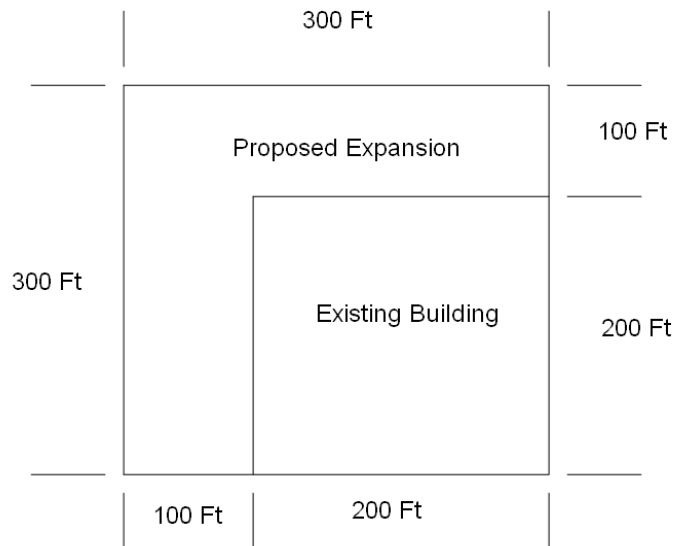

**Figure 4: Site Plan of Clareview Recreation Centre Facility**

As much of the same information as possible from the site was used in the design process. Three options were considered and analyzed to determine which would provide the greatest benefits relative to cost. Those options were: an extensive green roof on the entire structure, an intensive green roof on the entire structure, and an intensive roof on the new construction with an extensive on the old construction. The reason that an extensive roof on the new construction with an intensive on the old construction was not considered is that through research it was determined that since structural upgrades would be likely in order to make an intensive roof feasible, it was very unlikely that this option would prove to be economically attractive, and at the same time this option would provide very similar environmental benefits to the third option under consideration.

### 3.3.1.1 Assumptions Made About Site

The building was simplified to an existing building that was 200'X200' and a proposed expansion 100' wide that would wrap around 2 sides of the exiting building. The layout of the building analyzed is shown in Figure 5. The building was also simplified to be a 2 story structure with a flat roof.



**Figure 5: Layout of Building Considered**

The total area of the simplified roof design is 90,000 ft<sup>2</sup>, with 40,000 ft<sup>2</sup> being the existing building, and 50,000 ft<sup>2</sup> of new construction being attached. Based on the architectural drawings, it was estimated that the entire site was approximately 1000 ft X 1200 ft, giving an area of 1,200,000 ft<sup>2</sup>.

### 3.3.2 Design Considerations

During the evaluation of the various alternatives a number of factors were used to evaluate the performance of the green roofs. These considerations were the

installation costs of the green roofs, the added structural costs due to the roof's weight, the thermal benefits of the roof, the benefit to stormwater management, and the air quality improvement due to the green roof.

The green roof was designed based on common systems in use today. To determine a more accurate structural load and cost per square foot, a unique design was developed for each roof type using specific components, rather than purchasing a pre-built systems. Each component of the design is associated with a specific loading and cost, which are added up and used in the evaluation of the intensive and extensive designs.

#### 3.3.2.1 Installation Costs

Once a design was produced for both the extensive and intensive option, prices were determined for each component in the system. This was accomplished through a combination of online research and phone interviews, in which quotes were given for the pricing of each material for a 90,000 ft<sup>2</sup> roof. All of these quotes included the cost of installation. For the option where the proposed expansion is an intensive roof but the existing is extensive, it was assumed that the change in discount would be negligible so the prices were not changed.

These quotes were compiled in dollars per square foot, and were then added together. This total was multiplied by the roof area which was being built on for each system to arrive at a total cost of each alternative for materials and construction. The quoted prices can be seen in the Capstone Results section in Table 2 (page 57).

#### 3.3.2.2 Structural Considerations

In looking into the structural aspect of green roof construction, it was determined that accurate numbers could not be determined for the designed load resistance

capabilities of the existing building or the new construction without some kind of detailed plans, or direct input from an engineer on the project. For this reason, it was concluded that the best course of action in determining the structural feasibility of our green roof designs was to determine the additional dead loads that would be incurred by the green roof materials, and then consult with a licensed structural engineer as to the need for structural upgrades to the existing building or additional support in the new building.

The structural dead loads were determined by finding the unit weight for each material used in the construction of the extensive and intensive systems, and converting them all to pounds per square foot. The unit weights were determined through online research, and then compiled and summed.

Next a structural engineer was located within Stantec, and he was interviewed informally to discuss the proposed green roof designs. Cameron Franchuk is a structural engineer in the Edmonton office of Stantec and he took some time to provide his engineering judgment for our project. His estimations based on the loading that was previously determined were used to determine the approximate costs associated with the structural support of the green roof systems.

### 3.3.2.3 Thermal Performance

In order to quantify the value added to this project by the thermal benefits of a green roof research was conducted on the amount of energy required for heating and cooling building like the proposed recreation center. The Natural Resources Canada Office of Energy Efficiency's website provided an excel file which detailed the amount of energy consumed for both heating and cooling by all of the arts, entertainment, and recreation buildings in Alberta in 2007. This information was provided in units of petajoules (PJ). Given the total amount of floor space for this type of facility in meters squared ( $m^2$ ), the energy intensity for both heating and cooling were provided in megajoule per meter squared ( $MJ/m^2$ ). This provided the information needed to estimate the amount of natural gas and electricity per square foot which the proposed

recreational center would use for cooling and heating. Additional research was done on the costs of both natural gas and electricity in Alberta. Costs varied greatly therefore those used in calculating cost savings were specific to a project in which Direct Energy, a regulated natural gas provider in Alberta, provided a single year, dual fuel flat plan.

To determine the amount of energy that could be saved by an extensive or intensive green roof, the method chosen was that of a study performed in Pittsburg, Pennsylvania titled "Comparative Life Cycle Assessment of Green Roofs". This study contained a detailed energy use breakdown of a 12,000 ft<sup>2</sup> retail store in Pittsburg, with a quantification of how much energy could be saved by an intensive and extensive green roof, in terms of heating by natural gas and cooling by electricity. This analysis was related to our roof in Edmonton by first comparing the weather in the two locations, and then scaling the size of the roof.

After several different approaches were considered, the method that was selected for comparing the weather was to take the monthly average temperatures for the two locations, average those to one yearly value, and compare those numbers to determine a percentage difference.

Next the energy savings due to green roof systems on the Pittsburg store was determined in kWh/m<sup>2</sup> of floor area per year for both natural gas and electricity. These values were then scaled according to the total energy usage of the entire building. After adjusting for energy usage the values were then multiplied by the percentage difference in demand due to weather. These values were then multiplied by the area of the proposed recreation center to determine the total energy savings for the different designs. These energy saving were converted to dollar amounts by applying the prices which were found before.

#### 3.3.2.4 Stormwater Management Benefits

Stormwater management is benefited by the addition of a green roof because the green roof reduced that amount of stormwater that enters the sewer. This occurs

because the green roof absorbs water and retains it for consumption by plants and evaporation of water that is trapped in the soil. Green roofs also help to reduce peak flows by retaining the stormwater for a period of time before allowing it to flow into the sewer. For the purposes of this analysis only the benefit associated with the reduction of stormwater entering the sewer was considered.

The estimated reduction in stormwater entering the sewers was calculated by first estimating the amount of stormwater that could be expected to fall in Edmonton on the proposed green roofs. Then the percentage of rainwater a green roof could expect to absorb was estimated based on other green roof's performance. This percentage was then applied to the amount of stormwater a green roof generated in order to find the overall stormwater reduction.

The amount of stormwater generated by the green roofs was calculated by assuming that for every inch of rainfall 0.623 gallons of water would fall per square foot. Based on the average annual rainfall in Edmonton of 365.7 mm (National Climate and Information Archive, 2009) the amount of water falling on the existing roof and proposed expansion was calculated.

The estimated percent of stormwater the proposed green roofs could be expected to absorb was chosen based on the performances of green roofs in other case studies. The three case studies that were used to make this estimation were located in Pittsburg, Pennsylvania, Toronto, Ontario, and throughout Germany. In the Pittsburg study a 15cm extensive roof was assumed to absorb 60% of stormwater, and an intensive roof expected to absorb 85% (Kosareo and Ries, 2006). In the Toronto study a 7.5cm extensive green roof was found to absorb 57% of stormwater (Liu and Minor, 2005). In the study of German green roofs it was found that the median absorption of extensive green roofs was 45% and the median absorption of intensive green roofs was 75% (Mentens, 2005). The annual absorption rate will be dependant on a number of factors, including rainfall, frequency of heavy storms, and type and thickness of the green roof substrate. Since reliable data for the Edmonton area was not available for the performance of other green roofs, reasonable assumptions were made for the purpose of this analysis. It was assumed that the absorption of the extensive green roof was 50% of all stormwater and 80% for the intensive green roof.



Once the amount of stormwater falling on the existing building and the proposed expansion was calculated and the percent of stormwater an extensive and intensive green roof would absorb was estimated the stormwater reduction of the green roofs could be calculated. This was done for the cases of installing an extensive green roof on the existing building, installing an intensive green roof on the existing building, installing an extensive green roof on the proposed expansion, and installing an intensive green roof on the proposed expansion. This saving was calculated in L of stormwater runoff reduced per year. This reduction in stormwater that the green roof could create could affect the stormwater drainage costs of the site.

The stormwater drainage bill in Edmonton is calculated by multiplying four factors together. Those factors are the area of the site, the development intensity, the runoff coefficient and the drainage rate (EPCOR, 2010). While the development coefficient is typically 1 the runoff coefficient can range from 0.2 to 0.95 (City of Edmonton, 2010). The runoff coefficient is meant to reflect the varying level of imperviousness of different surfaces (for example, grass produces less runoff than concrete). An example of a land drainage runoff bill is shown in Figure 6. The runoff coefficient applied to a site depends on the site zoning.



 <b>DRAINAGE</b> <i>Provided by Drainage Services</i>		
1. Basic monthly service charge		\$4.58
2. Sewage charges, based on total water used or 18.3m <sup>3</sup> : 20 m <sup>3</sup> at 87.39¢ per m <sup>3</sup>		17.48
3. Land Drainage (area x development intensity x runoff coefficient x rate) 592.00m <sup>2</sup> x 1.00 x 0.50 at 1.232¢ per m <sup>2</sup>		3.65
<b>4. Your total drainage charges</b>		<b>\$25.71</b>

Figure 6: Example of Edmonton Land Drainage Bill (EPCOR 2010)

The money that could be saved by this reduction could only be utilized if a petition to the city was made to alter the runoff coefficient for the property to a lower

value than the zone the property belongs to. This petition can only be made to the city if a site has on site on-site stormwater management systems (City of Edmonton, 2010). Since the green roofs would reduce the amount of runoff flowing into the sewers the project fits within this category. However, according to Ryan Devlin, a Stantec employee within water resources, the city is far more likely to change the runoff coefficient for new building than for renovations. This must be taken into account when choosing which green roof is more feasible.

#### 3.3.2.5 Air Quality Benefits

The local quality of the air around a building can be measurably improved by the installation of a green roof. The plant life on green roofs can absorb and eliminate some polluting gasses in the air, and also the leaves of plants can trap particulate matter in the air. Although many different pollutants and chemicals can be removed by green roofs, four specific pollutants were concentrated on. This choice was made based on the availability of data, and on the study that we chose to utilize for the analysis conducted. The study whose method we used was “Quantifying Air Pollution Removal by Green Roofs in Chicago”. This paper outlined in detail how pollution removal was assessed in Chicago based on the total square footage of green roofs in the city, using a simulation and inputting real data collected throughout the city. The results of this paper assessed the mass of NO<sub>2</sub> (Nitrogen Dioxide), SO<sub>2</sub> (Sulfur Dioxide), O<sub>3</sub> (Ozone), and PM<sub>10</sub> (Particulate Matter of diameter ≤10 micrometers) removed from the air by the vegetation on all of the green roofs within the city area. The study then went on to calculate how much of each gas in grams could be absorbed by each square foot of rooftop, divided by plant height. This chart proved to be the most useful for our purposes, and was chosen as a basis for determining the mass of pollutants that could be removed in Edmonton.

The assumption was made that since Edmonton has a higher overall air quality, the mass of pollutants removed would be different between the two cities for a similar

roof. It was assumed that the change in amount of pollutants removed could be determined by finding the percentage difference in the amount of the three gasses and the particulate matter present in the air. Data was gathered about the air quality in both cities. Using data from 2008 for both cities, the average amount of each pollutant was determined for the entire year. The two sets of values were compared, and the percentage difference for each was determined from Chicago to Edmonton.

Next the amount of each gas and particulate matter that could be removed was determined for a roof in Chicago that was the size of the roof we are proposing (90,000 ft<sup>2</sup>). This was found using the chart produced in the study that related plant height to mass removed of each pollutant. The amount was determined by this method, and was then verified by an alternative method. This alternative was to take the actual amounts removed by green roofs in the Chicago study, and scale that down to the amount that would be removed if the size of all green roofs totaled to the size of the proposed roof.

Finally, the verified totals for each pollutant were scaled to indicate the difference in air quality from Chicago to Edmonton. Each was multiplied by the percentage difference that was found earlier to arrive at the final results of the analysis.

### **3.3.3 Design Decisions**

The benefits and costs of the three proposed designs were analyzed in terms of all of the above categories in order to determine which design provided the most benefits relative to its cost. Cost was determined as the sum of the materials and insulation price plus any structural upgrade costs, minus savings from improved thermal performance and stormwater reduction. The costs were then weighed against the environmental benefits provided by the improved air quality and reduction of runoff. Also considered was the increased life span of the roof, and the maintenance on the green roof.

### **3.4 *Presentation to Stantec***

An oral presentation was prepared and delivered to several Stantec employees. This consisted of a PowerPoint presentation which briefly introduced the sustainable technologies covered in the Best Practices Manual, discussed the process of developing the BPM, and highlighted its usefulness to Stantec. The presentation focused on the benefits of applying the BPM to sustainable Stantec projects.

## **4 Results and Discussion**

This section includes the results of both the BPM and the capstone design. A discussion on the use of the developed BPM and the lessons learned throughout the process provides insight into the current and future effectiveness of the manual. The capstone results demonstrate how several criteria were quantified in order to select the green roof design proposed. Cost and environmental benefits were considered equally in determining the most appropriate design.

### ***4.1 Application of Best Practices Manual***

The Best Practices Manual (BPM) was designed to assist Stantec employees in the process of selecting the most applicable sustainable design alternatives for a given project. By providing a brief technical description and highlighting potential benefits, potential risks and considerations, average costs, and recommended site characteristics, the technologies discussed can be evenly compared. These main categories represent the most common areas Stantec employees need when interacting with clients interested in implementing sustainable practices. The BPM allows all sustainable alternatives to be initially considered while providing a method for eliminating or further suggesting alternatives based on specific criteria. By comparing sustainable technologies with respect to the criteria provided in this manual, each category represents a new method of selecting from very different practices. For example, the manual allows for practices as different as green roofs and district energy to be compared solely in terms of their potential environmental benefits. The same is true for comparing any number of technologies in terms of costs and site applicability. By clearly defining the project's objectives, certain technologies would present a more direct approach to acquiring the expressed goals. Therefore, this manual should provide a timely method for conducting initial research, allowing the allocation of valuable time

to the exploration of more in-depth design considerations for the chosen/suggested alternatives.

While the manual serves as a current tool for Stantec employees, it is also designed to continue developing as additional research, general knowledge, and professional experience is added to it. For this reason, it is accessible to all Stantec employees through Stantec's intranet: StanNet. The Best Practices Manual developed has been added to the existing compilation of sustainable technologies provided on StanNet. Here, all Stantec employees have the ability to update the existing information and add entirely new sections. The site is currently managed by Klaas Rodenburg, Sustainable Design Coordinator, located in Stantec's center office in Edmonton, Alberta. Mr. Rodenburg recognizes the potential of providing an electronic receptacle for capturing the professional knowledge and expertise harvested within Stantec Inc. Providing a central location for this information allows the site to serve as a selection tool for now; however, its future use will be determined by those who participate in adding to it. Currently, the need for a tool to aid in the selection of sustainable alternatives has been identified. As this manual continues to develop, the initial need will be met, but additional internal needs will arise. That is why the BPM is what Mr. Rodenburg calls a "living document" because it has the ability to evolve into multiple tools, providing multiple forms of assistance to Stantec employees. Taking advantage of the full potential of this manual can lead to a number of results. For example, the electronic manual can evolve from an initial alternative selection tool to an interactive, on-line classroom which prepares Stantec employees for LEED accreditation. Regardless of the route of this living document, it continuously evolves representing the knowledge and experience acquired by employees over years of service. Stantec has generated a tool for fulfilling their commitment of one team providing infinite solutions.

The information compiled onto the electronic Best Practices Manual (eBPM) provides general information acquired through research and experience-based knowledge gathered through the completion of sustainable projects. Therefore, it is a representation of Stantec's ability to understand, design, construct, and maintain projects which implement the technologies addressed within the manual. The future growth and development of this manual would support Stantec's rising position as a

leader in sustainable design. By providing the knowledge to master current practices while highlighting areas for improvement, Stantec's eBPM will not only track the progress made, but also trigger innovative sustainable concepts and pave the way for continued progress. As this process occurs, Stantec Inc. will continue to generate a visual representation of their vigilance with all types of sustainable projects.

#### **4.1.1 Lessons Learned Applying Best Practices Manual**

Throughout the development of this manual, strategies that proved successful and strategies with room for improvement became apparent. Scheduling constraints were identified as one of the major limitations, while practical experiences became an unintentional advantage.

The scheduling of future projects should provide ample time for both research and analysis. Although the majority of time was allocated to on-line research, the focus of the project was to compile and deliver the information in the most useful way possible. This included developing additional material which evolved from an analysis of the research. Gathering information on a certain sustainable technology provided the tools for developing some suggestions and/or conclusions on how the delivered material would benefit Stantec. The time spent on research was necessary for detailing the initial design of the manual but resulted in too little time for analysis. Although both were completed in this project, additional time for developing a more thorough analysis would have added value to the final deliverable.

The order of research collection also resulted in some limitations due to scheduling. Therefore, future projects should collect all forms of information (online research, interview answers, etc.) as soon as possible in order to have enough time to include the most relevant content available. During this project, on-line research was conducted prior to expert employee interviews. This order allowed time for becoming familiar with the technology and selecting areas which could not be thoroughly completed through on-line research alone. However, that arrangement resulted in

minimal time for responses. While several interviews provided completely new perspectives on the specific technology, others provided support for information already gathered. In both cases, additional time for comparing all information, judging relevance and significance would have been beneficial.

Although a lot of planning went into the execution of this project, a major lesson learned was that everything is subject to change. Sudden opportunities arise which must be taken advantage of, perhaps altering an existing schedule or plan. The Kingston, Jamaica redevelopment project was such an opportunity. The Kingston assignment occurred after the main sections of the BPM had been made, but that existing outline provided a base structure for the Kingston project. Although this outline proved useful for the Kingston project, it also highlighted the problem areas in the current research and demonstrated the need for alternate forms of research, such as expert opinions. This preliminary version of the manual was used by several Stantec employees during a presentation to the Urban Development Corporation (UDC) in Kingston, Jamaica. The need for images was identified in order to easily create a presentation from the manual. Although the feedback from the presentation was limited, this preliminary manual was helpful in both framing the presentation and providing talking points. This practical experience provided some perspective on the use of the proposed deliverable and made it evident that the manual should be designed to highlight useful information while addressing the common concerns.

After reviewing the finished manual, one additional section could have added value to the final deliverable. A section on how to best implement various different technologies within the same project would have emphasized the holistic design approach promoted by sustainable development. This could have created several opportunities for new ideas and innovative projects to be incorporated within the manual.



## 4.2 Capstone Design Results

The design chosen for the extensive and intensive roofing systems can be seen below in Table 1.

**Table 1 – Green Roof Systems for Proposed Design**

	<b>Extensive</b>	<b>Intensive</b>
Plants	Short Grasses, Sedum	Grasses, Sedum, Small and Medium size Shrubbery
Substrate	American Hydrotech Inc. Extensive LiteTop Growing Medium (12 cm thick)	American Hydrotech Inc. Intensive LiteTop Growing Medium (50 cm thick)
Root Barrier / Protective Layer	Enviro Pro Non-Woven Polypropylene Geotextile Fabric	Enviro Pro Non-Woven Polypropylene Geotextile Fabric
Drainage Layer	3RFoam Medium Density 3RD35 Drainage Mat	5" perforated Schedule 40 PVC piping @ 6" O.C. with 3" gravel cover – No. 57 (3/4") gravel
Insulation Layer	Polystyrene (XPS) Rigid Foam Insulation	Polystyrene (XPS) Rigid Foam Insulation
Waterproofing	Fluid-applied rubberized asphalt membrane - American Hydrotech Inc. (Canada) Monolithic membrane 6125ev	Fluid-applied rubberized asphalt membrane - American Hydrotech Inc. (Canada) Monolithic membrane 6125ev
Existing Structure (Roof Decking)		

## 4.2.1 Installation and Maintenance Costs

The cost of buying and installing each component is shown in Table 2. This data was gathered by the method described in section 3.3.2.1 - Installation Costs (Page 44).

**Table 2 – Installation and Materials Cost for Each Green Roof Component**

	<b>Extensive</b>	<b>Intensive</b>
Plants	\$14.10 / ft <sup>2</sup>	\$34.60 / ft <sup>2</sup>
Substrate	\$1.75 / ft <sup>2</sup>	\$7.31 / ft <sup>2</sup>
Root Barrier / Protective Layer	\$0.13 / ft <sup>2</sup>	\$0.13 / ft <sup>2</sup>
Drainage Layer	\$1.50 / ft <sup>2</sup>	\$24.33 / ft <sup>2</sup>
Insulation Layer	\$0.80 / ft <sup>2</sup>	\$0.80 / ft <sup>2</sup>
Waterproofing	\$8.00 / ft <sup>2</sup>	\$8.00 / ft <sup>2</sup>
<b>TOTAL</b>	<b>\$26.28 / ft<sup>2</sup></b>	<b>\$75.17 / ft<sup>2</sup></b>

From this information the cost of each proposed green roof design was calculated. Those results are the following:

- All Extensive: \$2,365,200
- All Intensive: \$6,765,300
- Intensive on New, Extensive on Existing: \$4,320,800

The cost of a normal roof was assumed to be 50% of the cost of an extensive green roof (see green roofs BPM section for more detail). This led to the cost of a normal roof for the recreation center being \$1,182,600. Assuming this, the added cost of each green roof design over the cost of a normal roof is shown in Table 3.

**Table 3 – Added Cost of Installation for Each green Roof Design**

	Cost of Materials and Installation	Difference in Cost
Normal Roof (Base Case)	\$1,182,600	N/A
All Extensive	\$2,365,200	+ \$1,182,600
All Intensive	\$6,765,300	+ \$5,582,700
Intensive on New, Extensive on Existing	\$4,320,800	+ \$3,138,200

Based on research, the life span of a roof was assumed to be 15 years for a normal flat roof, and 45 years for a green roof. The maintenance costs of each design were then calculated versus the cost of maintaining a normal roof. It was assumed that the normal and extensive green roofs require only replacements, with no yearly maintenance. The intensive roof requires replacement, as well as irrigation. The cost of irrigation was set at \$0.020 /ft<sup>2</sup>, based on similarly dry environments with comparable water cost (Environmental Affairs, 2006). The cost of replacing a roof was assumed to be the same as the cost to install it originally. Through these assumptions, averaged yearly values for the maintenance on each roof were calculated.

**Table 4 – Annual Green Roof Maintenance Costs**

<b>Green Roof Design</b>	<b>Maintenance Costs (replacement + irrigation)</b>	<b>Difference in Cost</b>
Normal Roof (Base Case)	\$78,840 (replace @ 15 years)	N/A
All Extensive	\$52,560 (replace @ 45 years)	- \$26,280 / year
All Intensive	\$152,140 (irrigate and replace @ 45 years)	+ \$73,300 / year
Intensive on New, Extensive on Existing	\$97,018 (irrigate new and replace both @ 45 years)	+ \$18,178 / year

## 4.2.2 Thermal Performance

The improvement in thermal performance of the building under the three selected green roof designs can be seen below in terms of energy saved and equivalent money saved.

**Table 5 – Energy and Money Savings for Green Roof Alternatives**

	Energy Savings	Monetary Saving (US \$)
All Extensive	Heat: 3812.74 kWh/yr Electricity: 4916.42 kWh/yr <b>TOTAL: 8729.16 kWh/yr</b>	Heat: \$106.92 /yr Electricity: \$382.99 /yr <b>TOTAL: \$489.91 /yr</b>
All Intensive	Heat: 9264.29 kWh/yr Electricity: 10819.48 kWh/yr <b>TOTAL: 20083.87 kWh/yr</b>	Heat: \$259.81 /yr Electricity: \$842.84 /yr <b>TOTAL: \$1102.65 /yr</b>
Intensive on New, Extensive on Existing	Heat: 6235.65 kWh/yr Electricity: 7540.01 kWh/yr <b>TOTAL: 13775.66 kWh/yr</b>	Heat: \$174.87 /yr Electricity: \$587.37 /yr <b>TOTAL: \$762.24 /yr</b>

These prices were generated assuming a price structure of \$7.79 / GJ for natural gas heating and \$0.079 / kWh for electric power. For the Pittsburg study, the following chart was used to extract the energy savings information used in this analysis:

**Table 6: From “Comparative environmental life cycle assessment of green roofs” (Kosareo, 2006)**

Annual building energy consumption for the three roof alternatives

Roof option	Annual natural gas use (therm)	Change in natural gas use	Annual electricity use (kWh)	Change in electricity use
Control roof <sup>a</sup>	9211	21	2,122,699	16043
Extensive green roof option <sup>a</sup>	9202	12	2,115,407	8751
Intensive green roof option <sup>b</sup>	9190	Base case	2,106,656	Base case

<sup>a</sup>Numbers obtained from CTG Energetics Inc. DOE2 analysis.

<sup>b</sup>Extrapolated from extensive roof data.

The calculations used to convert these values to equivalent energy savings for our proposed roof in Edmonton can be seen in Appendix G: Capstone Design Calculations. The recorded temperature differential between Edmonton and Pittsburg on average can be seen below:

**Table 7 – Average Monthly Temperatures of Edmonton and Pittsburg in Fahrenheit (F °)**

	Jan	Feb	Mar	Apr	May	Jun	Jul	Aug	Sep	Oct	Nov	Dec	<b>AVG</b>
Edmonton, AB	11	17	27	42	53	60	64	62	52	42	25	15	39.0
Pittsburg, PA	28	31	40	50	60	68	73	71	64	53	42	33	50.9
						Average Temperature Difference						<b>11.9</b>	

Sources: National Weather Service (US), and National Climate Data & Information Archive (CA)

### 4.2.3 Stormwater Management Benefits

The amount of stormwater runoff a green roof system could reduce per year is shown in Table 8. Table 8 illustrates that the runoff difference between intensive and extensive green roofs is roughly 4,000 L/yr, and the difference between installing the green roof on the proposed expansion and the existing building is roughly 3,000 L/yr.

**Table 8: Stormwater Runoff Reduction**

<b>Green Roof Design</b>	<b>Stormwater Reduction (L/yr)</b>
All Extensive	1,534,075
All Intensive	2,454,520
Intensive on New, Extensive on Existing	2,045,433

In the city of Edmonton, for stormwater pricing purposes, the zoning of a property will determine the runoff coefficient of that property, thus determining the amount that the owners must pay for stormwater drainage per square meter or land area. Since there is not a direct conversion from liters of water saved to dollars saved an exact

number was not determined for stormwater savings. However it is possible to apply for a zone change depending on how much water can be treated or retained on site, leading to a lower runoff coefficient.

Right now the proposed site falls into two zones – AP (Public Parks Zone) and AGU (Urban Reserve Zone). Both of these zones will most likely have relatively low runoff coefficients, due to their typically high ratio of permeable to impermeable surfaces. Some examples of approved uses of these similar zones include public parks, indoor and outdoor recreation areas, drive in movie theaters, camp sites, and farms. There is currently an application in the system to change this entire site to US (Urban Services) which can include uses such as cemeteries, child care centers, recreational service buildings, and religious assembly structures. Due to this change, it was considered likely that there would be increased coverage by buildings and impermeable surfaces. It is known that the amount of building and parking area will be substantially increased by this project, so it was assumed that a runoff coefficient increase can be expected for this project.

Applying a green roof design to this building may provide the opportunity to apply for a coefficient reduction with the city. A significant amount of water will be absorbed by the roof. The runoff coefficients range from 0.2 to 0.95, and we would assume that the proposed site, with its amount of sport field area, would be towards the low end of this range. Although the coefficient of the site is not known, the following values were assumed for the change in coefficient after the installation of the green roof:

- All extensive: - 0.1
- Extensive on existing, intensive on new: - 0.15
- All intensive: - 0.2

Using these values, a monetary savings could be calculated. The results of this calculation can be seen in Table 9.

**Table 9 – Monetary Savings due to Stormwater Reduction**

	Change in Coefficient	Total Monetary Savings
All Extensive	- 0.1	\$1648.17 / year
All Intensive	- 0.2	\$3296.35 / year
Intensive on New, Extensive on Existing	- 0.15	\$2472.26 / year

#### 4.2.4 Air Quality Benefits

The results of the air quality analysis indicated that the proposed green roof systems in Edmonton could remove the following amount of pollutants from the air each year:

**Table 10 – Mass of Removed Pollutants by Proposed Green Roof Systems**

	O <sub>3</sub>	NO <sub>2</sub>	PM <sub>10</sub>	SO <sub>2</sub>
All Extensive	36.34 kg	12.62 kg	10.18 kg	2.26 kg
All Intensive	47.03 kg	15.92 kg	13.82 kg	2.89 kg
Intensive on New, Extensive on Existing	42.26 kg	14.45 kg	12.20 kg	2.61 kg

These values were determined by assuming that the extensive roof would be covered by short grasses less than 0.15 m tall, and the intensive roof would be covered by tall herbaceous plants approximately 1 m tall. The following chart was used to calculate the mass or removed pollutants for a 90,000 ft<sup>2</sup> green roof in Chicago:

**Table 11: From “Quantifying Air Pollution Removal by Green Roofs in Chicago” (Yang, 2008)**

Annual removal rate of air pollutants per canopy cover by different vegetation types in Chicago between August 2006 and July 2007

Type of vegetation	SO <sub>2</sub> (g m <sup>-2</sup> yr <sup>-1</sup> )	NO <sub>2</sub> (g m <sup>-2</sup> yr <sup>-1</sup> )	PM <sub>10</sub> (g m <sup>-2</sup> yr <sup>-1</sup> )	O <sub>3</sub> (g m <sup>-2</sup> yr <sup>-1</sup> )	Total (g m <sup>-2</sup> yr <sup>-1</sup> )
Short grass	0.65	2.33	1.12	4.49	8.59
Tall herbaceous plants	0.83	2.94	1.52	5.81	11.10
Deciduous trees	1.01	3.57	2.16	7.17	13.91

The non-vegetated surfaces were excluded from the calculation.

The results of this calculation were compared to another approach for verification. The total amount of the four pollutants removed by green roofs in Chicago was broken down in the study into its components. These totals (871.0 kg of O<sub>3</sub>, 452.25 kg of NO<sub>2</sub>, 234.5 kg of PM<sub>10</sub>, 117.25 kg of SO<sub>2</sub>) were for a total area of 19.8 ha of green roofs in the city of Chicago. When these values were scaled to 90,000 ft<sup>2</sup> and adjusted to fit the intensive to extensive ratio that was shown for Chicago green roofs (67.42% intensive / 32.58% extensive), they fell right in the middle of the totals that were determined for the extensive and intensive roofs, thus verifying that the calculated values from before were valid.

When comparing the levels of pollution in Chicago to Edmonton, the following differences were determined through the analysis of 2008 data:

Edmonton had -

- 3.2% less O<sub>3</sub>
- 35.24% less NO<sub>2</sub>
- 8.72% more PM<sub>10</sub>
- 58.39% less SO<sub>2</sub>

This data was gathered from two sources: a 2008 Report issued by the State of Illinois titled "Illinois Annual Air Quality Report 2008" (State of Illinois, 2008), and a Website maintained by the Clean Air Strategic Alliance of Alberta which contains the Alberta Ambient Air Data Management System (AAADMS) (Clean Air, 2009).

These changes were then applied to the calculated totals for an extensive and intensive 90,000 ft<sup>2</sup> Chicago green roof to determine the totals for similar green roofs in Edmonton. The results of these calculations can be seen in Table 1.

#### **4.2.5 Structural Considerations**

The loads determined for the two structural designs laid out in Table 12 are shown below:



**Table 12 – Structural Loading for Each Green Roof Component**

	<b>Extensive</b>	<b>Intensive</b>
Plants	4 lbs/ft <sup>2</sup>	10 lbs/ft <sup>2</sup>
Substrate	34 lbs/ft <sup>2</sup>	150 lbs/ft <sup>2</sup>
Root Barrier / Protective Layer	1 lbs/ft <sup>2</sup>	1 lbs/ft <sup>2</sup>
Drainage Layer	1 lbs/ft <sup>2</sup>	53 lbs/ft <sup>2</sup>
Insulation Layer	1 lbs/ft <sup>2</sup>	1 lbs/ft <sup>2</sup>
Waterproofing	3 lbs/ft <sup>2</sup>	3 lbs/ft <sup>2</sup>
<b>TOTAL</b>	<b>44 lbs/ft<sup>2</sup></b>	<b>218 lbs/ft<sup>2</sup></b>

These structural dead loads were presented to Cameron Franchuk, and he was asked to give his engineering judgment as to what type of structural changes loads like this would require in a building, new or existing.

It was established that because the building under consideration is a recreation center, it will have a variety of large open spaces, including a gymnasium, pool, library, and ice rink. This means that most likely the critical structural value that will be designed for is live load deflection under normal conditions. For an increase in dead load of 44 psf for the extensive green roof, a deflection governed design may very well remain unchanged. Based on a rough estimation, it was concluded that if the design is strength based instead of deflection based, then an increased load of 44 psf would result in an increase in structural costs totaling to around 10% to 20%. For this analysis, it will be assumed that the design is in fact governed by deflection, since this is more common in these types of structures.

For the intensive roof, an increased dead load of 218 psf is much more of a concern than the load induced by the extensive roof. It was estimated that an increase in load of more than 200 psf could increase the structural costs of the project by as much as 2 to 4 times. This is a very large price differential for a project of this scale. The columns and foundations would all have to be increased in size to handle the additional weight, and the beams may need to be upgraded also. Due to this requirement of upgrading all columns and foundations, it was concluded that putting an intensive green roof of this type onto the existing building is not feasible. To replace these essential building components without demolishing the building would be next to impossible, therefore the all intensive roof option was ruled out. Putting an intensive roof on the new construction is still a possibility; however we will assume that the minimum structural

cost of such an undertaking will double the original price of the steel frame and foundation. Table 13 shows the anticipated structural cost of the building (based on case studies and some calculations that can be seen in Appendix G: Capstone Design Calculations) as well as the anticipated added structural cost for each design.

**Table 13 – Added Structural Costs due to Green Roof Designs**

	Original Cost	Total Cost	Added Cost
All Extensive	\$2,056,000	\$2,426,000	<b>\$370,000</b>
All Intensive	\$2,056,000	N/A	<b>Cost Prohibitive</b>
Intensive on New, Extensive on Existing	\$2,056,000	\$4,276,400	<b>\$2,220,400</b>

### **4.3 Capstone Conclusions**

The final choice of design took into account the environmental benefits that each roof could provide, the amount of money that could be saved yearly by each design, and the amount of money that each design would cost to install and maintain. Table 14 shows all of the costs and benefits associated with each design.

**Table 14 – Costs and Benefits of Green Roof Design Options**

	All Extensive	All Intensive	Intensive on New, Extensive on Existing
Thermal Benefits (energy savings)	8729.16 kWh / yr	20083.87 kWh / yr	13775.66 kWh / yr
Air Quality Benefits (emission reduction) (represents yearly values [kg / year])	O <sub>3</sub> - 36.34 kg NO <sub>2</sub> - 12.62 kg PM <sub>10</sub> - 10.18 kg SO <sub>2</sub> - 2.26 kg	O <sub>3</sub> - 47.03 kg NO <sub>2</sub> - 15.92 kg PM <sub>10</sub> - 13.82 kg SO <sub>2</sub> - 2.89 kg	O <sub>3</sub> - 42.26 kg NO <sub>2</sub> - 14.45 kg PM <sub>10</sub> - 12.20 kg SO <sub>2</sub> - 2.61 kg
Stormwater Benefits (runoff reduction)	1,534,075 L / year	2,454,520 L / year	2,045,433 L / year
Thermal Savings (monetary)	- \$489.91 / yr	- \$1102.65 / yr	- \$762.24 / yr
Stormwater Savings (monetary)	- \$1648.17 / yr	- \$3296.35 / yr	- \$2472.26 / yr
Added Maintenance Cost (monetary)	- \$26,280 / yr	+ \$73,300 / yr	+ \$18,178 / yr
<b>Difference in Yearly Costs</b>	<b>- \$28,418.08 / yr</b>	<b>+ \$68,901/ yr</b>	<b>+ \$14,943.50/ yr</b>
Added Installation Cost (monetary)	\$1,182,600	\$5,582,700	\$3,138,200
Added Structural Costs (monetary)	\$370,000	Cost Prohibitive	\$2,220,400
<b>Total Added Installation Cost</b>	<b>\$1,552,600</b>	<b>Cost Prohibitive</b>	<b>\$ 5,358,600</b>
Simple Payback Period	54.6 Years	Installation Not Economically Feasible	Added cost per year – no payback

Based on all of this information, it was concluded that the extensive roof on both the existing building and the new construction was the best option. This design was the only one that represented a cost savings over time as compared to an intensive green roof. The environmental benefits provided by this design are less than those of the other two designs, but not significantly less when compared to the base case of a normal flat roof.

## Works Cited

1. The Ontario Association of Landscape Architects, 3 Church Street, Suite 407 , Toronto, Ontario M5E 1M2. Copyright OALA 2007. Accessed February 11, 2010. <http://www.oala.on.ca/index.aspx>
2. "[Sci-Tech Encyclopedia](#): Landscape architecture." Copyright © 2010 Answers Corporation. Accessed 2/16/2010. <http://www.answers.com/topic/landscape-architecture>

## ***Green Roof Sources***

1. Banting, Dr Doug et al. "Report on the Environmental Benefits and Costs of Green Roof Technology for the City of Toronto" Oct. 2005. Accessed on Jan. 20, 2010. <http://www.toronto.ca/greenroofs/pdf/fullreport103105.pdf>
2. Kosareo, Lisa and Ries, Robert. "Comparative environmental life cycle assessment of green roofs" Apr. 2006. Accessed on Jan. 25, 2010. Accessible on [www.sciencedirect.com](http://www.sciencedirect.com)

## ***Green Walls Sources***

1. Capital Regional District. "What is a Living Wall?" Copyright 1996-2010. Accessed Jan. 27 2010. <http://www.crd.bc.ca/watersheds/lid/walls.htm>
2. Irwin, George. "The Green Wall Column" 2008 & 2009. Accessed Jan. 26 2010. [http://www.greenroofs.com/archives/green\\_walls.htm](http://www.greenroofs.com/archives/green_walls.htm)
3. Plant Connection, Inc. "How the Green Wall Works" 2010. Accessed Jan. 25 2010. Available at <http://www.myplantconnection.com/>
4. Smith, S.E. "What are Green Walls?" 2010. Accessed Jan. 25 2010. <http://www.wisegeek.com/what-are-green-walls.htm>
5. Stainless Steel Solutions. "Planting advice on Green Walls & Façades" 2009. Accessed Jan. 26 2010. <http://www.s3i.co.uk/facadeplantingadvice.php>

## ***Permeable Pavement Sources***

1. Dauphin County Conservation District (DCCD) "Porous Asphalt" Accessed Jan.25, 2010. <http://www.dauphincd.org/swm/BMPfactsheets/Porous%20Asphalt%20fact%20sheet.pdf>

2. EPA, "Porous Asphalt Pavement", 2009, Accessed Jan. 25, 2010.  
<http://cfpub.epa.gov/npdes/stormwater/menuofbmps/index.cfm?action=browse&Rbutton=detail&bmp=135&minmeasure=5>
  
3. Kloss, Christopher; Calarusse, Crystal "Rooftops to Rivers Green Strategies for Controlling Stormwater and Combined Sewer Overflows" University of Maryland School of Public Policy, 2006. Accessed Jan. 25, 2010
  
4. NAHB Research Center – "Permeable Pavement Tech Specs" Accessed\_Jan.25, 2010. Available at  
[http://www.toolbase.org/PDF/DesignGuides/PermeablePavement\\_TechSpec.pdf](http://www.toolbase.org/PDF/DesignGuides/PermeablePavement_TechSpec.pdf)
  
5. Wong, Eva, "Reducing Urban Heat Islands: Compendium of Strategies Cool Pavements", 2005, Accessed Jan. 25, 2010.  
<http://www.epa.gov/hiri/resources/pdf/CoolPavesCompendium.pdf>

### ***Stormwater Infiltration Systems Sources***

1. EPA, "Low Impact Development: A Literature Review", 2000, Accessed Jan. 25, 2010. <http://www.epa.gov/owow/nps/lid/lid.pdf>
  
2. Low Impact Development Center Inc, "Bioretention", 2007, Accessed Feb. 1, 2010.  
[http://www.lid-stormwater.net/bio\\_costs.htm](http://www.lid-stormwater.net/bio_costs.htm)

3. Prince George's County, Maryland Department of Environmental Resources," Low-Impact Development Design Strategies", 1999, Accessed Feb. 2, 2010.

<http://www.epa.gov/owow/nps/lid/lidnatl.pdf>

### ***Constructed Wetlands Sources***

1. Cameron et al. "Pollutant removal from municipal sewage lagoon effluents with a free-surface wetland." Environment Canada, McGill University, and University of Guelph. January 1st 2003. Copyright Elsevier Science Ltd 2003. Available at [Sciencedirect.com](http://www.sciencedirect.com).

2. Ghermandi et al. "The role of free water surface constructed wetlands as polishing step in municipal wastewater reclamation and reuse." School for Advanced Studies in Venice Foundation and Aquafin NV Dijkstraat. February 7th 2007. Copyright Elsevier B.V. 2007. Accessed 1/29/2010. Accessible at [Sciencedirect.com](http://www.sciencedirect.com).

3. Rousseau et al. "Constructed wetlands for water reclamation." UNESCO-IHE Institute for Water Education, Ghent University, and Université Laval. September 6th 2001. Copyright Elsevier B.V. 2008. Accessed 2/1/2010. Available at [Sciencedirect.com](http://www.sciencedirect.com).

4. Vymaza, Jan. "Horizontal sub-surface flow and hybrid constructed wetlands systems for wastewater treatment." Science Direct and Duke University Wetland Center, Nicholas School of the Environment and Earth Sciences, Durham, NC 27708, USA. July 11<sup>th</sup> 2005. Copyright 2005 Elsevier B.V. Accessed 1/25/2010. Available at [Sciencedirect.com](http://www.sciencedirect.com)

## ***Rainwater Harvesting Sources***

1. Chilton, J.C et al. "Case study of a rainwater recovery system in a commercial building with a large roof." Science Direct, The University of Nottingham, Nottingham, UK, South Bank University, London, UK, Safeway Stores PLC, Middlesex, UK, and Gerald Tobias Associates, West Sussex UK. April 12<sup>th</sup>, 2000. Copyright © 2000 Elsevier Science Ltd. Accessed 1/20/2010. Available at [Sciencedirect.com](http://www.sciencedirect.com)

## ***Xeriscaping Sources***

1. American Lawns. "Types of Grasses found in America" 2010. Accessed Feb. 1 2010. <http://www.american-lawns.com/grasses/grasses.html>

2. Beaulieu, David. "Top 10 Tips for Low-Maintenance Landscaping" 2008. Accessed Jan. 19, 2010. [http://landscaping.about.com/od/lazylandscaping/tp/low\\_maintenance.htm](http://landscaping.about.com/od/lazylandscaping/tp/low_maintenance.htm)

3. Beaulieu, David. "Xeriscaping Plants: Drought-Resistant Plants" 2009. Accessed Jan. 29 2010. <http://landscaping.about.com/cs/cheaplandscaping1/a/xeriscaping.htm>

4. Iannotti, Marie. "Xeriscape Gardening – Planning for a Water Wise Garden" 2008. Accessed Jan. 19 2010. <http://gardening.about.com/od/gardendesign/a/Xeriscaping.htm>



5. Northern Garden Supply. "Drip Irrigation" 2007. Accessed Feb. 1 2010.  
<http://www.dripirrigation.ca/>

6. Smith, S.E. "What is Xeriscaping" Copyright 2010. Accessed Jan. 19 2010.  
<http://www.wisegeek.com/what-is-xeriscaping.htm>

### ***District Energy Sources***

1. Chow, T.T. et al. "Applying district-cooling technology in Hong Kong" Jan. 2004.  
Accessed Jan. 19, 2010. Available at <http://www.sciencedirect.com>

2. Mahone, Douglas et al. "Absorption Chillers" The New Buildings Institute. Nov, 1998.  
Accessed Feb. 11, 2010. [http://www.newbuildings.org/downloads/guidelines/  
AbsorptionChillerGuideline.pdf](http://www.newbuildings.org/downloads/guidelines/AbsorptionChillerGuideline.pdf)

3. Pöyry Energy Consulting "The Potential and Costs of District Heating Networks" The  
Department of Energy and Climate Change". 2009. Accessed Jan. 25, 2010.  
[http://www.decc.gov.uk/Media/viewfile.ashx?FilePath=What%20we%20do/UK%20energy%20supply/Energy%20mix/Distributed%20Energy%20Heat/1\\_20090505121831\\_e\\_@\\_204AreportprovidingatechnicalanalysisandcostingofDHnetworksv30.pdf&filetype=4](http://www.decc.gov.uk/Media/viewfile.ashx?FilePath=What%20we%20do/UK%20energy%20supply/Energy%20mix/Distributed%20Energy%20Heat/1_20090505121831_e_@_204AreportprovidingatechnicalanalysisandcostingofDHnetworksv30.pdf&filetype=4)

4. Werner, Sven. "District Heating and Cooling" 2004. Accessed Jan. 20, 2010.  
Available at <http://www.sciencedirect.com>

## ***Air Handler Condensate Recovery Sources***

1. EPA, "Air Handler Condensate Recovery at EPA", 2009, Accessed Jan. 25, 2010, Available at <http://www.epa.gov/oaintrnt/water/airhandler.htm>
2. Wilson, Alex; Navaro, Rachel. "Alternative Water Sources: Supply-Side Solutions for Green Buildings" May 1, 2008. Accessed Jan. 20, 2010. <http://www.buildinggreen.com/auth/article.cfm/ID/3903/>
3. Wilson, Alex; Navaro, Rachel. "Water: Doing More with Less". 2008, Accessed Feb. 23, 2010. <http://www.buildinggreen.com/auth/article.cfm/2008/2/3/Water-Doing-More-With-Less/>

## ***Capstone Sources***

1. "Canadian Climate Normals 1971-2000." National Climate and Information Archive. April 30<sup>th</sup> 2009. Accessed 2/18/2010. [http://climate.weatheroffice.gc.ca/climate\\_normals/results\\_e.html?Province=ALL&StationName=Edmonton&SearchType=BeginsWith&LocateBy=Province&Proximity=25&ProximityFrom=City&StationNumber=&IDType=MSC&CityName=&ParkName=&LatitudeDegrees=&LatitudeMinutes=&LongitudeDegrees=&LongitudeMinutes=&NormalsClass=A&SelNormals=&StnId=1867&](http://climate.weatheroffice.gc.ca/climate_normals/results_e.html?Province=ALL&StationName=Edmonton&SearchType=BeginsWith&LocateBy=Province&Proximity=25&ProximityFrom=City&StationNumber=&IDType=MSC&CityName=&ParkName=&LatitudeDegrees=&LatitudeMinutes=&LongitudeDegrees=&LongitudeMinutes=&NormalsClass=A&SelNormals=&StnId=1867&)
2. Clean Air Strategic Alliance: Data Warehouse. "Data Reports". 2009. Accessed Feb. 23, 2010. <http://www.casadata.org/Reports/SelectCategory.asp>

3. Environmental Affairs Department: City of Los Angeles. "Green Roofs – Cooling Los Angeles: A Resource Guide". 2006. Accessed Mar.1, 2010.  
[http://www.fypower.org/pdf/LA\\_GreenRoofsResourceGuide.pdf](http://www.fypower.org/pdf/LA_GreenRoofsResourceGuide.pdf)
  
4. Government of Alberta Utilities Consumer Advocate. "Price Summary". 2006. Accessed Feb. 23, 2010. <http://www.ucahelps.gov.ab.ca/204.html>
  
5. Kosareo, Lisa and Ries, Robert. "Comparative environmental life cycle assessment of green roofs" Apr. 2006. Accessed on Jan. 25, 2010. Accessible on [www.sciencedirect.com](http://www.sciencedirect.com)
  
6. "Land Drainage Utility FAQ for Non-Residential Customers." City of Edmonton website. Copyright © 2010, City of Edmonton. Accessed 2/23/2010.  
[http://www.edmonton.ca/for\\_residents/flooding\\_sewers/land-drainage-utility-faqs-for.aspx](http://www.edmonton.ca/for_residents/flooding_sewers/land-drainage-utility-faqs-for.aspx)
  
7. Liu, K. and Minor, J. "Performance evaluation of an extensive green roof" May, 2005. Accessed on Jan. 16, 2010. <http://nparc.cisti-icist.nrc-cnrc.gc.ca/npsi/ctrl?action=rtdoc&an=5751909&article=0>
  
8. Mentens, Jeroen et al. "Green roofs as a tool for solving the rainwater runoff problem in the urbanized 21st century?" Department of Land Management, Laboratory for Forest, Nature & Landscape Research, KULuleuven, Vital Decosterstr. 102, B-3000 Leuven, Belgium. May 13th 2005. Copyright Elsevier B.V. 2005. Accessed 2/16/2010. Available at [Sciencedirect.com](http://www.sciencedirect.com)

9. Natural Resources Canada Office of Energy Efficiency. "Comprehensive Energy Use Database Tables: Arts, Entertainment, and Recreation Space Conditioning Second Energy Use by End-Use and by Energy Source". 2009. Accessed Feb. 23, 2010. Available at [http://oee.nrcan.gc.ca/corporate/statistics/neud/dpa/trends\\_com\\_ab.cfm](http://oee.nrcan.gc.ca/corporate/statistics/neud/dpa/trends_com_ab.cfm)

10. State of Illinois: Environmental Protection Agency. "Illinois Annual Air Quality Report 2008". 2008. Accessed Feb. 24, 2010. <http://www.epa.state.il.us/air/air-quality-report/2008/index.html>

11. "Your water bill." EPCOR Utilities Inc. Accessed 2/23/2010. <http://www.epcor.ca/en-ca/Customers/paying-your-bill/Understanding-your-bill/Pages/your-water-bill.aspx>

12. "Canadian Climate Normals 1971-2000." National Climate and Information Archive. April 30<sup>th</sup> 2009. Accessed 2/18/2010. [http://climate.weatheroffice.gc.ca/climate\\_normals/results\\_e.html?Province=ALL&StationName=Edmonton&SearchType=BeginsWith&LocateBy=Province&Proximity=25&ProximityFrom=City&StationNumber=&IDType=MSC&CityName=&ParkName=&LatitudeDegrees=&LatitudeMinutes=&LongitudeDegrees=&LongitudeMinutes=&NormalsClass=A&StnNormals=&StnId=1867&](http://climate.weatheroffice.gc.ca/climate_normals/results_e.html?Province=ALL&StationName=Edmonton&SearchType=BeginsWith&LocateBy=Province&Proximity=25&ProximityFrom=City&StationNumber=&IDType=MSC&CityName=&ParkName=&LatitudeDegrees=&LatitudeMinutes=&LongitudeDegrees=&LongitudeMinutes=&NormalsClass=A&StnNormals=&StnId=1867&)

# Appendix A: Best Practices Manual



# **Best Practices Manual: Landscape Architecture**

Prepared By:  
Peter Cacciatore  
James Hogan  
Rebecca Mattern  
Angel Munoz

Feb 26th 2010

# BPM Table of Contents

- Appendix A: Best Practices Manual ..... 76
- BPM Table of Contents ..... 78
- Introduction ..... 83
- Green Roofs..... 85
  - Technical Description ..... 87
    - Extensive Green Roofs ..... 88
    - Intensive Green Roofs ..... 89
  - Potential Benefits..... 90
  - Potential Risks and Considerations ..... 94
  - Estimated Costs..... 95
    - Extensive Green Roofs ..... 95
    - Intensive Green Roofs ..... 96
  - Recommended Site Characteristics..... 97
  - Potential LEED Credits ..... 98
  - Relevant Stantec Projects ..... 99
  - Sources ..... 102
- Green Walls ..... 108
  - Technical Description ..... 109
    - Green Façades ..... 111
    - Living Walls ..... 114
  - Potential Benefits..... 117
  - Potential Risks and Considerations ..... 118
  - Estimated Costs..... 118
  - Recommended Site Characteristics..... 119
  - Potential LEED Credits ..... 120
  - Relevant Stantec Projects ..... 121
  - Sources ..... 122
- Permeable Pavements ..... 128
  - Permeable Asphalt ..... 132

Potential Benefits .....	134
Potential Risks and Considerations.....	135
Estimated Costs .....	136
Recommended Site Characteristics .....	138
Permeable Concrete.....	139
Potential Benefits .....	140
Potential Risks and Considerations.....	141
Estimated Costs .....	142
Recommended Site Characteristics .....	144
Potential LEED Credits .....	145
Relevant Stantec Projects .....	146
Sources .....	148
Stormwater Run-off Infiltration Systems.....	158
Bioretention Basins/Rain Gardens.....	161
Potential Benefits .....	165
Potential Risks and Considerations.....	166
Estimated Costs .....	171
Recommended Site Characteristics .....	173
Vegetated Swales.....	178
Estimated Costs .....	179
Recommended Site Characteristics .....	179
Potential LEED Credits .....	180
Relevant Stantec Projects .....	180
Sources .....	182
Rainwater Harvesting .....	188
Technical Description .....	189
Potential Benefits.....	191
Potential Risks and Considerations .....	193
Estimated Costs.....	195
Recommended Site Characteristics.....	197
Potential LEED Credits .....	197



Relevant Stantec Projects .....	198
Sources .....	201
Constructed Wetlands .....	205
Technical Description .....	206
Potential Benefits.....	208
Potential Risks and Considerations .....	209
Estimated Costs.....	210
Recommended Site Characteristics.....	211
Surface Flow (SF) Wetlands.....	211
Potential Benefits of SF Wetland.....	212
Estimated Costs of SF Wetland .....	215
Subsurface Flow (SSF) Wetlands.....	216
Potential Benefits of SSF Wetlands .....	216
Estimated Costs of SSF Wetlands .....	219
Vertical Flow (VF) Wetlands .....	220
Potential Benefits of VF Wetlands.....	221
Estimated Costs of VF Wetlands.....	222
Hybrid Wetland Systems .....	222
Potential Benefits of Hybrid Wetlands .....	223
Estimated Costs of Hybrid Wetlands.....	224
Potential LEED Credits .....	224
Relevant Stantec Projects .....	225
Sources .....	230
Xeriscaping .....	236
Technical Description .....	237
Planning & Design.....	237
Soil Improvement .....	238
Minimizing Turf.....	239
Appropriate Plant Selection.....	239
Efficient Irrigation .....	240
Use of Mulch .....	241

Maintenance .....	242
Potential Benefits.....	242
Potential Risks and Considerations .....	244
Estimated Cost .....	244
Water .....	245
Maintenance .....	245
Recommended Site Characteristics.....	245
Minimizing Turf.....	245
Maintenance .....	252
Potential LEED Credits .....	254
Relevant Stantec Projects .....	254
Sources .....	256
District Energy.....	261
Technical Description .....	262
District Cooling.....	263
District Heating.....	265
Combined District Heating and Cooling .....	267
Potential Benefits.....	267
District Heating.....	267
District Cooling.....	268
Combined Systems.....	269
Potential Risks and Considerations .....	270
Estimated Costs.....	271
Recommended Site Characteristics.....	272
Potential LEED Credits .....	273
Relevant Stantec Projects .....	273
Sources .....	275
Air Handler Condensate Recovery System.....	283
Technical Description .....	284
Potential Benefits.....	287
Potential Risks/Downsides .....	288

Estimated Costs.....	289
Recommended Site Characteristics.....	290
Potential LEED Credits .....	291
Sources .....	292

## Introduction

The degrading state of the natural environment due to human actions is causing a reevaluation of the effectiveness of current engineering practices. As the negative environmental impacts of traditional development strategies have become more apparent specific engineering practices have been targeted for reevaluation. This evaluation has identified several deficiencies in current practices, but it also has identified several opportunities for improvement. For example, conventional land development has led to the constant interruption of many natural processes, and has thus created a domino effect of detrimental consequences. Engineers across the globe then face the challenge of developing sustainable alternatives to current technologies. However, the urgency for mitigation of environmental impacts leaves little room for testing, data collection, and analysis of these latest innovations. Therefore, the development of best practice manuals outlining the most efficient practices is a common method for tracking and promoting the most up-to-date techniques available.

This report is a compilation of the best practices specific to sustainable landscape architecture. Within the sustainable movement landscape architecture is a discipline that attempts to improve the way humans interact with the environment (Ontario Association of Landscape Architects (OALA), 2007). This is crucial to ensuring that future works have the least degree of environmental impact possible. Improving this interaction is done through better understanding how natural landscapes operate as well as how our interactions affect it. In doing so architects, engineers, and those involved in land development will be able to foresee the consequences of their work. This knowledge, combined with incentive programs and mandates by governments, can promote sustainable development so that in the future we may meet our goal of completely sustainable infrastructure.

The sustainable topics covered in this report include green roofs, green walls, permeable pavements, stormwater infiltration systems, constructed wetlands, rainwater harvesting, and xeriscaping. All of these practices strive to improve the way humans interact with the environment and mitigate the negative consequences of land

development. As these technologies become more common and data regarding their long-time performance becomes available further opportunities for improvement will be evident.

Also contained in this report are the topics of air handler condensate recovery, and district heating/cooling. These topics are not traditional landscape architecture practices, but are linked with the overall sustainable goals of lessening environmental impacts by saving energy and reducing potable water usage. For a more detailed explanation of the inclusion of these topics, please see the MQP report associated with this project.

Within the field of landscape architecture continuous innovation will lead to the achievement of the overall goals of sustainable development. As current technologies are improved and new technologies are engineered this document will serve as a receptacle for experience-based knowledge. Our hope is that this manual will become a “living document”, which can be constantly updated and added to as new research and information on these technologies emerges over time. It will continue to expand in order to demonstrate the evolution of technologies while representing the current set of best practices.

## Green Roofs

The idea of green roofs has been around for centuries, with many houses in Scandinavia and Germany having home made green roofs throughout history. The idea of “greening” the rooftops in urban areas however is a relatively new idea which has gained much support in the last decade or so. Green roofs are continuing to gain popularity, especially in North America. For example, the number of green roofs in the US rose by 35% from 2007 to 2008 (Choi, 2009).

New legislation is being enacted in some areas which will mandate the use of green roof technology on certain buildings. For instance a new bylaw has been introduced in Toronto which states that all residential buildings over six stories must have a green roof as of 2009. By 2011 all industrial buildings will be required to have green roof cover of 2000 m<sup>2</sup> or 10% of the roof area.

Another approach that has been utilized is to offer incentive to developers who will use green roof technology. For instance the Clean Energy Stimulus and Investment Assurance Act of 2009 in the United States included a section proposing to give a 30% tax credit to owners who employed green roof technology (Cantwell, 2009). In Chicago a program has been implemented which accelerates the permitting process for any developer who employs a certain percentage of green roofs or meets certain LEED objectives. This fast tracking of permitting can save the developer a great deal of money so it has proven to be an effective means of encouraging green roof use.

Green roof technology has been shown to have significant benefits in certain circumstances for the environment and for the building occupants and owners and the use of green roofs is being constantly increased. There is real opportunity for organizations such as Stantec to take advantage of this growing market. The incentives for developers are creating a greater market for green roofs than ever before, especially in the area of feasibility studies, as developers try to figure out if constructing a green roof is worth the cost.

Green roofs are seen as a possible solution to short and long term energy reduction and water conservation goals. One example is the United States Postal Service Distribution Center in New York City, which has constructed the largest green roof in the city as part of the USPS goal of reducing overall energy usage by 30% by 2015 (USPS, 2009). Other examples include: California's Goal to have all new buildings using net-zero energy by 2030, an executive order by President Obama to have all federal buildings meet the same goal, and a goal by Philadelphia to reduce energy consumption of all buildings by 10% and government buildings by 30% before 2015.

### Green Roofs

- Cost:
  - For an extensive green roof – around US\$20 / ft<sup>2</sup> or about 50% more than a regular flat roof
  - For an intensive green roof – anywhere from US\$25 / ft<sup>2</sup> to US\$75 / ft<sup>2</sup>
- Benefits:
  - Better thermal performance – represents potential energy savings especially in warm, sunny weather
  - Improved stormwater management and runoff mitigation
  - Improved air quality
  - Reduction of the heat island effect
  - Other environmental benefits (e.g. habitat for bird and insects) and aesthetic appeal, especially for intensive roofs
  - Extends life of the roof
- Risks
  - Some possible concerns about water quality of runoff
  - May require structural upgrade to building to carry extra load
  - May not be as effective in certain climates

## Technical Description

Green Roofs are flat or slightly pitched roofs of buildings which have been converted to or originally designed to be a habitat for plant life. The goal of a green roof is usually to have as much of the roof covered with foliage as possible. Green roofs all consist of the same general structure to give them the ability to support plant life without damaging the structure beneath. A typical green roof consists of at least the following layers from bottom to top: roof decking (metal or concrete), insulation, waterproof membrane, drainage layer, growing medium / soil, plant life (Banting, 2005).

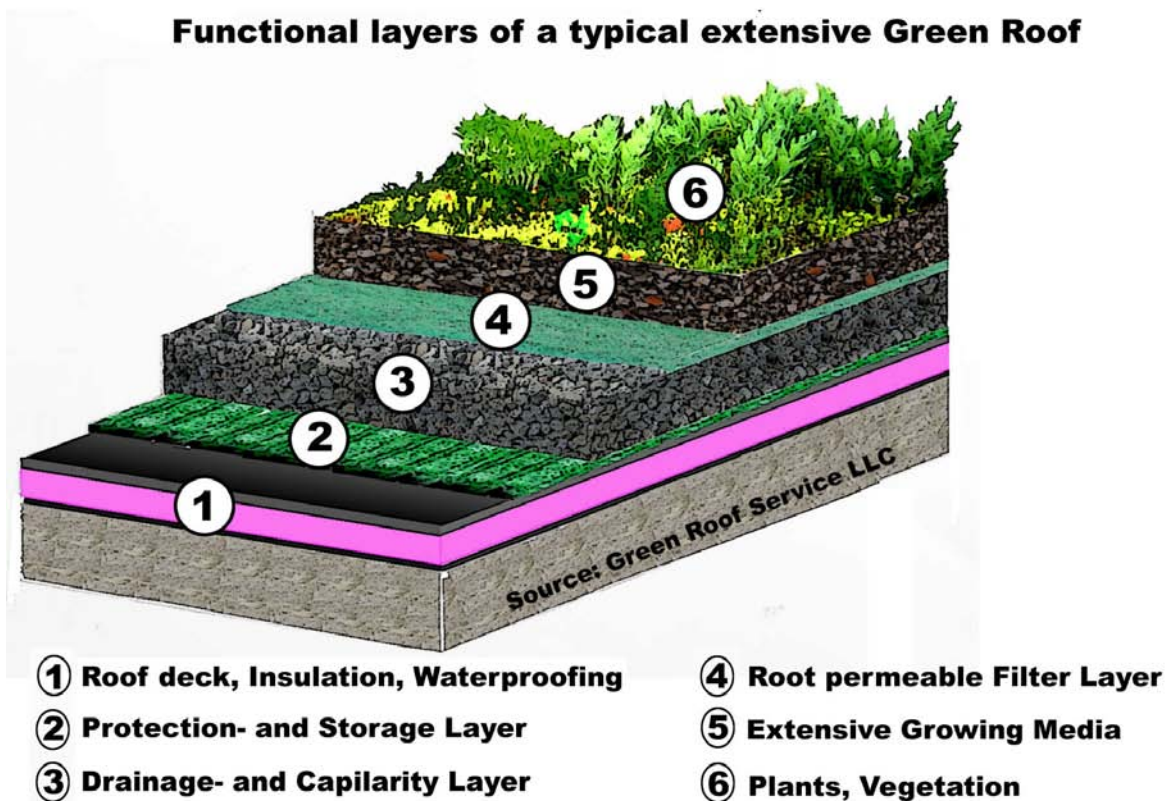

Figure 7: Extensive Green Roof Diagram

There are many varieties of this basic design, but several features are essential. The waterproof membrane is necessary to protect the structure from any undrained water, and the drainage layer is needed to eliminate excess water that is unable to be



absorbed by the soil or growing medium. Soil is used in cases where more load can be carried by the roof, but sometimes lightweight growing medium, or substrate, replaces it (Kosareo, 2006). Substrate usually consists of a nutrient rich mixture of organic material and minerals designed to be as lightweight as possible. (Liptan, 2003)

There are three main varieties of green roofs; extensive, intensive, and semi-intensive. Extensive refers to smaller scale green roofs which usually have thinner layers of soil and support smaller plants. Intensive roofs are the opposite, supporting large plants (even trees) with thick layers of soil. Semi-intensive green roofs are those roofs which fall in the middle of the two extremes, sharing some qualities of both. Due to the variation in definition of semi-intensive roofs only extensive and intensive green roofs will be addressed here. The reader should keep in mind that in some instances it may be the best option to create a semi-intensive roof by choosing properties that do not fall into either of the other two categories.

## **Extensive Green Roofs**

Extensive green roofs are “smaller scale” green roofs. They generally utilize a growing medium or substrate instead of soil in order to remain lightweight. Extensive roofs usually have a substrate thickness of between 2cm to 20cm, depending on the types of plants being used. (Banting, 2005) Typically herbaceous plants, grasses, moss, and sedum are used to cover an extensive roof. This type of roof is designed to be low maintenance and typically requires little or no watering. Usually access to the roof is limited to occasional maintenance to protect the plants and to limit the live loading on the roof. This type of roof is more common due to its lower cost and reduced structural demands. An extensive green roof ranging from 4cm to 10cm will have a loading ranging from 50kg/m<sup>2</sup> to 100kg/m<sup>2</sup>. (Wark, 2003) Another study on extensive green roofs estimated structural requirements to be an additional 70kg/m<sup>2</sup> to 170kg/m<sup>2</sup> in addition to the weight of the roof below the waterproof membrane. (Oberndorfer, 2007)

Extensive roofs are appropriate for retrofitting to an existing structure due to their relatively light weight.

Extensive green roofs have less aesthetic appeal than intensive roofs but still may be more visually pleasing than a traditional flat roof covered with gravel ballast or rubber mat.



**Figure 8: Extensive Green Roof on Chicago City Hall**

## **Intensive Green Roofs**

Intensive Green roofs are systems which tend to house larger plants with deeper layers of growing medium. Intensive green roofs can have a strong aesthetic appeal and often times are accessible to the public with paths, benches, or other features of a normal outdoor park. Medium sized trees, large shrubs, and other large plants are common features of intensive green roofs along with small ponds or pools. The growing

medium on intensive roofs ranges from 15 cm deep up to several meters deep in order to support the larger trees. Intensive roofs often require regular maintenance and irrigation, so they may incur some operation and maintenance costs on the building owner. The weight of such a system can vary greatly and intensive roofs typically require their own structural support system to prevent overloading the roof. This makes intensive roofs unsuitable for retrofitting to an existing structure, as the beams that support the roof of a building are not easily removed or replaced. (Wark, 2003)

Intensive green roofs are worth the cost to building owners because they offer significant energy savings due to their increased thermal performance as compared to extensive green roofs. They absorb greater volumes of storm water and better regulate the air temperature and quality allowing them to provide increased environmental benefits.

### ***Potential Benefits***

One great benefit of green roofs is their thermal properties. Green roofs have the effect of cooling the air above them, as opposed to traditional roofs which tend to greatly increase ambient temperature above them. (Liu, 2003) The reason for this is that plant life tends to absorb sunlight and turn the radiation into energy and reflect excess sunlight. The plants also cool themselves through the process of transpiration in which they release water that is evaporated, similar to animals sweating. Moisture also evaporates directly from the soil. Evapotranspiration is a term used to describe the combined affect of direct evaporation and plant transpiration. Regular roofs absorb the sun's rays, heat up, and radiate that heat back out to the air. This produces an effect where the air heats up directly above rooftops and contributes to the heat island effect. The heat island effect is where the air temperature in an urban environment is higher due to the aggregate effect of many manmade surfaces absorbing solar radiation. (EPA, 2009) Green roofs can locally reduce this effect, and widespread use of green roofs in a city has the possibility to mitigate the heat island effect substantially. (Kumar, 2003)

Another thermal effect of green roofs is to significantly reduce the temperature of the roof itself. As a traditional roof absorbs solar radiation throughout the day it can gain significant amounts of heat.

- (Liu, 2003) In one study a reference roof with a dark colored membrane peaked at 70C in the afternoon of a summer day while the membrane in an extensive green roof peaked at just 25C.
- (Liu, 2005) In another study a dark and light colored regular roof reached about 80C and 70C respectively on a summer day. In this study extensive green roofs were installed on these membranes in late July, and from then on the temperature peaked at no more than 40C for both roofs.
- (Kosareo, 2006) Reducing thermal strain on the roofing material lengthens the life of the roof. Research estimates that the average membrane roof lasts about 15 years, but an average extensive green roof lasts 45 to 50 years, due to the greenery and soil protecting the roofing materials from sunlight, rain, wind, and other detrimental weather.

In addition to lengthening the life of the roofing material regulating the temperature of the roof will also regulate the temperature inside the building. In cold climates green roofs provide added insulation to the roof. Some studies find that in very dry and cold environments the transpiration process can cancel much of the added insulating benefits. Still, most research finds at least some prevention of heat flow through the roof in the cold months, which helps keep the internal building temperature warmer.

- (Liu, 2003) One study in Ottawa found a reduced heat flow through the roof of 26% in the winter. Heat gain in the summer through the roof was reduced by 95%
- (Liu, 2005) In Toronto a study found reduced heat flow through the roof averaging from 10% to 30% in winter, and from 70% to 90% in summer

- (Spala, 2006) A study in Athens, Greece found little change in heating load in the winter, but considered this a benefit since the cooling load was reduced by 15% to 39% and often attempts to decrease cooling needs result in an increase in heating loads.
- (Kerr Wood, 2009) in this paper it was reported that one green roof in Ottawa was shown to reduce heat flow through the roof by 75% in the summer. A different study in Vancouver found an 80% reduction in heat flow into the building in the summer, and a 40% reduction in flow out of the building in the winter.

Green roofs provide a significant benefit with respect to stormwater mitigation. In an Urban area rainstorms often produce large quantities of runoff from the many impermeable surfaces in a city, as impermeable surfaces can make up as much as 45% of total ground area in a built up city. (Liptan, 2003) This runoff must be collected and treated as wastewater because it often carries many harmful chemicals and other hazards with it. Green roofs help to reduce the flow of stormwater by absorbing significant amounts of rain before they begin to produce runoff.

Since the stormwater benefits of a green roof are based largely on the thickness of the soil extensive roofs tend to be less effective at absorbing rainwater than intensive roofs. One study found that roofs with 15 to 20 cm of growing medium absorbed 60% or more water annually, where roofs with 2 to 4 cm absorbed only 40% (Kerr Wood, 2009). Similarly, extensive roofs tend to have less plant cover than intensive roofs so their thermal benefits will be reduced compared to intensive roofs.

Studies have found varying rates of rain water absorption based on location and season.

- (Liu, 2005) - Research in Toronto found that the average reduction in roof runoff from a green roof in the fall and summer was about 57%.
- (Liptan, 2003) In Portland, Oregon several green roofs of varying types averaged a 10% to 35% reduction during the wet season and a 65% to 100% reduction during the dry season.

- (Kloss, 2006) The National Resource Defense Council in the US found that an extensive green roof on the Chicago city hall reduces stormwater runoff by an average of 75%.
- (Kloss, 2006) A report prepared in Milwaukee found that the combination of green roofs, rain gardens, and green parking lots reduced stormwater flow by as much as 22% to 76%.
- (Kloss, 2006) Another study in Portland, Oregon found that one particular roof reduced runoff by about 58% and absorbed close to 100% of stormwater during the warm season.
- (Kloss, 2006) The Ford Motors plant in Dearborn, Michigan recently installed the largest green roof to date, at over 10 acres. This roof is expected to retain 100% of the first inch of rainfall.
- (Kloss, 2006) In one study it was estimated that to “green” 6% of Toronto’s roofs would cost about \$36 million and would reduce stormwater runoff by about 1 billion gallons per year.

The previously cited studies also show how the peak flow of a storm can be delayed by green roof installation, so that the maximum flow of water at any one time is reduced, lowering the stress on the stormwater management system (Kloss, 2006).

Green roofs may also positively affect the air quality of the surrounding area. The presence of greenery in an area can reduce concentrations of ozone, carbon dioxide, and provide indirect benefits such as smog reduction through heat island mitigation.

- (Banting, 2005) One report noted that a study on Los Angeles estimated that the reduction of air conditioner use due to insulation by green roofs, combined with a temperature reduction of 3 degrees due to reduced heat island effect, could reduce average NO<sub>x</sub> emissions in the city by as much as 350 tons per day.
- (Clark, 2007) Another study also found that green roofs could absorb significant amounts of nitrogen dioxide which is a large contributor to ground level ozone, a significant pollutant in urban areas.

- (Yang, 2008) An analysis performed in Chicago which summed the absorption of pollutants for approximately 71% of the total green roof coverage in the city (amounting to about 19.8 Ha) found that 1675 kg of pollutants were removed by the surveyed roofs in one year. Of this, 52% was ozone, 27% was nitrogen dioxide, 14% was particulate matter, and 7% was sulfur dioxide.

### ***Potential Risks and Considerations***

The main environmental issue raised concerning green roofs is their affect on water quality. Although runoff through soil can provide filtration for the water to some extent, growing medium and fertilizers may pollute soil to some extent depending on the composition of the soil or substrate. One study found that green roof runoff had significantly reduced heavy metal presence, specifically copper, zinc, cadmium, and lead. (Kosareo, 2006) However, several studies have noted an increase in phosphorus release from green roofs compared to normal urban runoff. (Liptan, 2003)(Berndtsson, 2007) It is speculated that this release of phosphorous can be controlled by choosing more carefully formulated substrates, but phosphorous release is often a concern with any fertilized area. Green roofs have been shown to act as sinks for nitrates and nitrogen compounds which can act as pollutants in runoff. (Berndtsson, 2007) Overall it seems that green roofs have a somewhat neutral effect on water quality although care should be taken when choosing soil or substrate to avoid release of fertilizers and chemicals. Use of pesticides should also be avoided.

The only other major consideration for green roofs is the potential need to upgrade the building structurally to carry the extra load of the soil and plant life. This is less of a concern for extensive green roofs, but with intensive green roofs the added dead load almost always requires that the structure be designed differently to account for the additional weight.

## ***Estimated Costs***

Due to the varying nature of green roof design it can be difficult to estimate a general cost for the installation of a green roof. The cost will vary based on location, size, roof structure, and type of design to name a few. Since there is not one rule of thumb range for all green roofs, some examples have been provided below of various projects and their associated costs. As an extremely rough estimation, it can be said that in 2009 in North America an extensive green roof will cost around \$20/ ft<sup>2</sup>, or about 50% more than installing a normal roof. Since intensive green roofs are even more variable, the case studies reviewed did not produce a reasonable median value. However an estimation that could be used is the price found in our capstone design project, which puts the price of an intensive green roof in Canada around \$75/ ft<sup>2</sup>. This is on the high end of normal green roof pricing for an intensive roof, so a reasonable range including the case study values can be given as about \$25/ ft<sup>2</sup> to \$75/ ft<sup>2</sup>.

## **Extensive Green Roofs**

The cost of installing an extensive roof varied greatly. Many case studies have given both estimated and real costs of installing an extensive green roof versus a normal flat roof. The following costs are estimations based on case studies from different regions

- (Clark, 2007) –Ann Arbor, Michigan  
Mean cost of a flat roof: \$167 / m<sup>2</sup>, with standard deviation of: \$28 / m<sup>2</sup>  
Mean cost of extensive green roof: 39% higher (\$232.13 / m<sup>2</sup>)
- (Banting, 2005) –Waterloo, Ontario:  
Cost of retrofitting \$75 to \$90 / m<sup>2</sup> more than flat roofing
- (Carter, 2007) –North America  
Mean cost of a green roof adds \$5 to \$10 / ft<sup>2</sup> over cost of flat roof



Total extensive green roof cost is \$12 to \$18 / ft<sup>2</sup>

- (Liptan, 2003) – Portland Oregon  
Mean flat roof cost: \$2 to \$10 / ft<sup>2</sup> new construction, \$4 to \$15 / ft<sup>2</sup> for retrofit  
Mean extensive green roof cost: \$5 to \$12 / ft<sup>2</sup> new, \$7 to \$20 / ft<sup>2</sup> for retrofit
- (Wong, 2002) – Singapore  
Flat roof: \$49.25 / m<sup>2</sup>  
Extensive Green Roof: \$89.86/ m<sup>2</sup>
- (Oberndorfer, 2007) – Location not specified  
Extensive green roof cost: \$10 to \$30 / ft<sup>2</sup> new

## **Intensive Green Roofs**

Costs of intensive roofing systems are almost always more than a comparable extensive system, although the cost still varies greatly depending on location and source. The following costs are estimations based on case studies, although only one is specific to a region. This is due to the less prevalent nature of intensive green roofs.

- (Banting, 2005) [citing a study by Acks, K. in 2003]  
Intensive green roof: \$24/ft<sup>2</sup>
- (Banting, 2005)  
With mainly shrubs – 22.4% more than flat roof  
With mainly trees – 42.6% more than flat roof
- (Wong, 2002) – Singapore  
Flat roof: \$49.25 / m<sup>2</sup>  
Built up flat roof: \$131.60/ m<sup>2</sup>  
Intensive Green Roof with 80% shrub cover: \$171.93/ m<sup>2</sup>  
Intensive Green Roof with 50% tree cover: \$197.16/ m<sup>2</sup>
- (Oberndorfer, 2007)

In addition to lower roof structure: minimum of \$200 / m<sup>2</sup> at a substrate depth of 20 cm, with cost increasing with depth of medium

### ***Recommended Site Characteristics***

Green roofs can potentially be added to any structure in the world as long as the building has the structural requirements to carry the additional load. However, buildings in certain environments will benefit much more from the application of green roof technology than others. The factors that matter most in determining the suitability of green roof technology for a region are the following:

- Annual rainfall
- Frequency of rain-heavy storms
- Daily and seasonal temperature
- Amount of direct sunlight
- Urban or rural environment

These factors will all affect the performance of a green roof in terms of the benefits that the building owner and the local environment will receive from it. Aesthetic appeal is the only quality that will be unaffected by the location of the site, and some owners may choose to construct a green roof based purely on this factor.

Rainfall and storm frequency affect the green roof in terms of stormwater management capability and maintenance. Green roof technology should be more readily applied in areas with frequent heavy rains for two reasons. The first is that green roofs help to mitigate large quantities of storm water runoff in cases of heavy rainfall. The second reason is that in areas of low rainfall green roofs may require watering, which can raise maintenance costs. In this case extensive roofs can be used since they are usually planted with drought resistant species, but even this may not be enough to mitigate the cost of irrigation.

Local temperature and amount of direct sunlight both affect the thermal performance of a green roof. It has been found that green roofs are less effective at preventing heat loss during cold weather (as shown by case studies cited above in the potential benefits section). In climates where there is a very long winter or the heating demand of buildings will far outweigh the cooling demand green roofs may not be as practical. On the other hand, green roofs have proven excellent at lowering the buildings temperature on hot days. Additionally, the amount of direct sunlight matters because it is the main factor in determining how much green roofs will lower the cooling demands of a building. In a structure where direct sunlight on the roof is a main cause of cooling load, green roofs will be most effective. Also, the plants on the roof will need a certain amount of sunlight to survive, so a building that spends the majority of the day in partial or complete shade may have problems with keeping shaded plants alive.

Finally, urban environments are the best application for green roofs because they are where most of the environmental problems exist to which green roofs are a solution. Stormwater management and heat island effect are very seldom an issue in more rural environments so the use of a green roof becomes less appealing.

### ***Potential LEED Credits***

- **SS Credit 6.1: Stormwater Design—Quantity Control**

1 Point

To limit disruption of natural hydrology by reducing impervious cover, increasing on-site infiltration, reducing or eliminating pollution from stormwater runoff and eliminating contaminants.

- **SS Credit 6.2: Stormwater Design—Quality Control**

1 Point

To limit disruption and pollution of natural water flows by managing stormwater runoff.

- **SS Credit 7.2: Heat Island Effect—Roof**

1 Point

To reduce heat islands<sup>1</sup> to minimize impacts on microclimates and human and wildlife habitats.

- **EA Credit 1: Optimize Energy Performance**

1–19 Points

To achieve increasing levels of energy performance beyond the prerequisite standard to reduce environmental and economic impacts associated with excessive energy use.

- **IE Q Credit 7.1: Thermal Comfort—Design**

1 Point

To provide a comfortable thermal environment that promotes occupant productivity and well-being.

## ***Relevant Stantec Projects***

Below is a list of projects that have been undertaken by Stantec that may be useful references when considering the construction of a green roof. More projects related to green roofs can be found in the Stantec Marketing Knowledge Center.

### **1. Stantec Centre - Green Roof**

Location: Edmonton, Alberta, Ca

Description: An extensive green roof about 850 m<sup>2</sup> in size. Contributed to a LEED Silver rating for the building. Roof is not accessible, but is fully planted with local flora

Link: [http://marketingexcellence/projectprofile\\_preview.aspx?id=10&project=7042](http://marketingexcellence/projectprofile_preview.aspx?id=10&project=7042)

## 2. Green Roof for Con Edison's Learning Center

Location: [Long Island City, New York, US](#)

Description: An extensive green roof constructed using modular trays pre-planted with a variety of sedums. Roof was analyzed for ability to support added load.

Link: [http://marketingexcellence/projectprofile\\_preview.aspx?id=10&project=16580](http://marketingexcellence/projectprofile_preview.aspx?id=10&project=16580)

## 3. The Evergreen State College Seminar II

Location: [The Evergreen State College Seminar II](#)

Description: Built a new portion of campus for a Washington state college. Among other green features, included one of the largest green roofs in the pacific northwest.

Link: [http://marketingexcellence/projectprofile\\_preview.aspx?id=10&project=9728#](http://marketingexcellence/projectprofile_preview.aspx?id=10&project=9728#)

## 4. Alberta Ecoroof Initiative

Location: [Calgary, Alberta, Ca](#)

Description: A project constructed to provide technical data about green roof performance in Alberta. Employed a variety of features to help measure best performance in Alberta's unique climate.

Link: [http://marketingexcellence/projectprofile\\_preview.aspx?id=10&project=10511#](http://marketingexcellence/projectprofile_preview.aspx?id=10&project=10511#)

## 5. Vancouver Convention Centre Expansion

Location: [Vancouver, British Columbia, Ca](#)

Description: Features many innovative sustainable features, including one of the largest green roofs in Canada, contributing to a LEED Gold certification.

Link: [http://marketingexcellence/projectprofile\\_preview.aspx?id=10&project](http://marketingexcellence/projectprofile_preview.aspx?id=10&project)

=8543#

## **6. Bronx Terminal Market's Building J**

Location: [New York City, New York, US](#)

Description: Project is aiming to achieve LEED Silver certification through the use of several sustainable features, including an extensive green roof.

Link: [http://marketingexcellence/projectprofile\\_preview.aspx?id=10&project=13111](http://marketingexcellence/projectprofile_preview.aspx?id=10&project=13111)

## **7. Jomax Hotel**

Location: [Phoenix, Arizona, US](#)

Description: A very sustainably designed hotel which is aiming for LEED gold certification. One feature included is a variety of green roofs on various parts of the building.

Link: [http://marketingexcellence/projectprofile\\_preview.aspx?id=10&project=11527](http://marketingexcellence/projectprofile_preview.aspx?id=10&project=11527)

## Sources

1. Banting, Dr Doug et al. "Report on the Environmental Benefits and Costs of Green Roof Technology for the City of Toronto" Oct. 2005. Accessed on Jan. 20, 2010. <http://www.toronto.ca/greenroofs/pdf/fullreport103105.pdf>

*A comprehensive report on the benefits and costs of green roofs, and how they apply specifically to Toronto*

2. Berndtsson, Justyna et al. "Runoff water quality from intensive and extensive vegetated roofs" July, 2007. Accessed on Jan. 25, 2010. Accessible on [www.sciencedirect.com](http://www.sciencedirect.com)

*Studies the levels of certain chemicals and pollutants in runoff from several green roofs, in comparison to similar standard roofs.*

3. Carter, Timothy and Fowler, Laurie. "Establishing Green Roof Infrastructure Through Environmental Policy Instruments" May, 2007. Accessed Jan 27, 2010. available at [www.springerlink.com](http://www.springerlink.com)

*Discusses strategies for implementing green roof technology on a large scale through political changes to infrastructure*

4. Cantwell, Sen. Maria. "S.320: Clean Energy Stimulus and Investment Assurance Act of 2009" Jan. 2009. Accessed Feb. 23, 2010. <http://www.govtrack.us/congress/bill.xpd?bill=s111-320>

*A bill introduced to the senate which offers tax incentives for the construction of green roofs (among other things)*

5. Choi, Charles Q. "Green Roofs Curb Global Warming, Study Finds" Oct. 2009. Accessed Feb. 23, 2010. <http://www.livescience.com/environment/091005-green-roofs.html>

*An article about green roofs and how their use can mitigate the presence of green house gasses.*

6. Clark, Corrie et al. "Green Roof Valuation: A Probabilistic Economic Analysis of Environmental Benefits" Mar. 2007. Accessed on Jan. 26, 2010. Accessible on <http://pubs.acs.org/>

*Addresses a number of facets of green roofs, including air quality mitigation.*

7. EPA - Environmental Protection Agency. "Heat Island Effect" Feb. 2009. Accessed on Jan. 26, 2010. <http://www.epa.gov/heatisland/about/index.htm>

*Describes the urban heat island effect*

8. Greenroofs.com "Green Roof FAQs" 2007. Accessed on Jan. 20, 2010. <http://www.greenroofs.com/Greenroofs101/faqs.htm>

*A web site devoted to green roof promotion and education*



9. Kerr Wood Leidal Associates “Design Considerations for the Implementation of Green Roofs” 2009. Accessed on Jan. 27, 2010.

<http://www.metrovancouver.org/about/publications/Publications/greenroofreporttext.pdf>

*A comprehensive overview of the design of green roofs*

10. Kloss, Christopher and Calarusse, Crystal; “Rooftops to Rivers: Green Strategies for Controlling Stormwater and Combined Sewer Overflows” June 2006. Accessed on Jan. 19, 2010. Accessible on [www.sciencedirect.com](http://www.sciencedirect.com)

*A summary of how stormwater affects the environment, especially in an urban setting, and various strategies to help mitigate the effects*

11. Kosareo, Lisa and Ries, Robert. “Comparative environmental life cycle assessment of green roofs” Apr. 2006. Accessed on Jan. 25, 2010. Accessible on [www.sciencedirect.com](http://www.sciencedirect.com)

*Analyzes a case study to determine the environmental impacts of green roof use, installation and demolition.*

12. Kumar, Rakesh and Kaushik, S.C. “Performance evaluation of green roof and shading for thermal protection of buildings” July, 2003. Accessed on Jan. 16, 2010. Accessible on [www.sciencedirect.com](http://www.sciencedirect.com)

*An evaluation of the thermal properties of a particular green roof versus a regular roof under the same conditions.*

13. Lazzarin, Renato M et al. "Experimental measurements and numerical modelling of a green roof" Nov. 2004. Accessed on Jan. 19, 2010. Accessible on [www.sciencedirect.com](http://www.sciencedirect.com)

*Analyzed thermal properties of a green roof, concentrating on evapotranspiration*

14. Liptan, Tom and Strecker, Eric. "Ecoroofs (Greenroofs) – A More Sustainable Infrastructure" Jan. 2003. Accessed on Jan. 19, 2010. Accessible on [www.sciencedirect.com](http://www.sciencedirect.com)

*Addresses green roofs as a means of runoff control*

15. Liu, K. and Baskaran, B. "Thermal performance of green roofs through field evaluation" May, 2003. Accessed on Jan. 16, 2010. Accessible on [www.sciencedirect.com](http://www.sciencedirect.com)

*Another evaluation of the thermal properties of a particular green roof versus a regular roof under the same conditions.*

16. Liu, K. and Minor, J. "Performance evaluation of an extensive green roof" May, 2005. Accessed on Jan. 16, 2010. <http://nparc.cisti-icist.nrc-cnrc.gc.ca/npsi/ctrl?action=rtdoc&an=5751909&article=0>

*An analysis of Toronto green roofs for thermal and Stormwater benefits*

17. Oberndorfer, Erica et al. "Green Roofs as Urban Ecosystems: Ecological Structures, Functions, and Services" Nov. 2007. Accessed on Jan. 27, 2010 from

Caliber: The University of California Journals Press.  
<http://caliber.ucpress.net/doi/abs/10.1641/B571005>

*Describes the ecological interaction of green roofs with the urban environment*

18. Spala, A. et al. "On the green roof system. Selection, state of the art and energy potential investigation of a system installed in an office building in Athens, Greece" June 2006. Accessed on Jan. 25, 2010. Accessible on [www.sciencedirect.com](http://www.sciencedirect.com)

*A specific case study is analyzed for thermal and energy efficiency. Heat load was not reduced but cooling load was greatly reduced.*

19. USPS (United States Postal Service). "Green Roof: Morgan Processing and Distribution Center (P&DC)". Oct. 2009. Accessed Feb. 23 2010.  
[www.usps.com/green/pdf/green\\_roof\\_oct\\_09.pdf](http://www.usps.com/green/pdf/green_roof_oct_09.pdf)

*A brief overview of the USPS distribution center green roof project in New York*

20. Yang, Jun et al. "Quantifying air pollution removal by green roofs in Chicago" Mar. 2008. Accessed on Jan. 25, 2010. Accessible on [www.sciencedirect.com](http://www.sciencedirect.com)

*Quantifies the removal of air pollution by green roofs.*

21. Wark, Christopher and Wark, Wendy. "Green Roof Specifications and Standards: Establishing an emerging technology" The Construction Specifier. Aug. 2003. Accessed Jan 27, 2010. [http://www.greenroofs.com/pdfs/newslinks-03\\_construction\\_specifier.pdf](http://www.greenroofs.com/pdfs/newslinks-03_construction_specifier.pdf)

*Gives specific construction practices used in the building of green roofs*

22. Wong, Nyuk Hien et al. "Life cycle cost analysis of rooftop gardens in Singapore" April 2002. Accessed on Jan. 16, 2010. Accessible on [www.sciencedirect.com](http://www.sciencedirect.com)

*A life cycle cost analysis of a theoretical green roof in Singapore, in terms of energy saving and other benefits*

## Green Walls

Green walls have been used in countries like Germany, Switzerland, and Scandinavia for over three decades (The Author, 2009). ). With the recent popularity of the green roofs in North America, green walls have also begun to gain popularity. People use vines and vegetation on the walls of houses for shade from the sun, insulation from the wind and cold and aesthetic purposes (Bass, 2007). By the year 2030, total energy consumption and greenhouse gas emissions are predicted to both quadruple (Science for Global Insight, 2010). Since green walls insulate buildings, which helps reduce energy consumption, and provide natural air filtration, which helps improve air quality, the demand for green walls will continue grow.

- The cost per square foot roughly ranges from US \$100.00 to \$175.00 depending on the size and the plant material.
- Green walls insulate buildings and provide sound absorption.
- Green walls remove volatile organic compounds from the air and can improve the mental health of nearby persons.
- They require standard plant maintenance with the possible added difficulty of being high in the air and difficult to reach.



**Figure 9: Green Walls (Econoplas, 2007)**

## ***Technical Description***

Green walls are interior and exterior walls that have vegetative covering and come in a variety of designs and sizes with a wide range of practical decorative vegetation. They utilize almost any type of plant, depending on the region (Smith, 2010). Orientation, climate, sunlight, wind exposure, and maintenance regimes all influence the palette of plants suitable for any given project (Plant Connection, 2010). There are two major types of green walls. A green façade, which uses climbing plants to form a wall covering, and a living wall, which uses modular plants in a panel system. Green walls are also known as bio-walls, vegetated walls, eco-walls, and vertical gardens (Capital Regional District, 2010). No matter what it is called, green walls have made quite an impact. Even Time Magazine recognized its possibilities and named green walls the 31<sup>st</sup> best invention of 2009 (Time Magazine, 2009).

Although most green walls are relatively low maintenance, five key components have been identified to successfully sustain a green wall. The divisions are location, structural inspections, irrigation, drainage, and plant maintenance (Irwin, 2008). Location is important because it dictates how to access the green wall. Usually a method similar to the installation technique is ideal. Structural inspections are recommended from a preventative standpoint. Check the waterproofing and penetration methods, bracket assembly, structural wall, and water flow. Irrigation must also be inspected for clogged emitters, leaks, filter replacement, and mechanical components. Drainage maintenance is also essential to prevent water collection, whether indoors or outdoors. Materials like leaves, soil, mud and garbage should be cleared out of drains. Lastly, plant maintenance is crucial to have a thriving green wall. Weeding, pruning, dusting, and/or deadheading should be used to help preserve the health of the plants (Irwin, 2008). Weeding consists of removing unwanted plant life because it can detract from the water and nutrients needed by the desired vegetation. It is important to prune a green wall by cutting back the plant to prevent overgrowth. Cleaning off dust is only necessary for indoor green walls because dust blocks sunlight

from the plant and reduces its ability to photosynthesize (Iannotti, 2010). Deadheading simply refers to removing the dying and dead ends of plants by pulling or cutting them off. By eradicating the useless parts, the flora has more chances to bloom and live longer (Beaulieu, 2009).

Determining the loading for green walls is crucial to a successful design. The weight of the plants, the wind load exerted, the dew and rain amount, the weight of snow, and the weight of the actual structure should all be taken into consideration when determining the loads. The weight for green walls varies greatly, from  $1 \text{ kg/m}^2$  to  $50 \text{ kg/m}^2$  of plant area. Wind resistance is minimal on climbers with a shallow profile, while climbers with lots of foliage and branches could produce a lot of stress on its supports. Also, too much growth might damage the support system. Structures with deciduous plants must anticipate supporting double the weight of the plants themselves, to account for dew, rain and snow. Structural systems with evergreen plants must be able to hold triple the weight of the plant to account for dew, rain and snow. The physical structures' weight must be measured with the height above the ground incorporated. If the structure is supported at the top and bottom, then the top should carry the whole load and  $\frac{1}{2}$  the wind load while the bottom needs to support only  $\frac{1}{2}$  the wind load (Stainless Steel Solutions, "Green Wall Trellis System" 2009).

When building a green wall, irrigation needs to be taken into consideration. Most indoor and outdoor systems have built-in irrigation systems. Normally a  $\frac{1}{4}$ " drip irrigation tube is installed at the top of each panel with cutouts approximately every 6 inches. The cutouts have to line up with the pressure compensating emitters that allow for free flow of water through each vertical row of cells. Capillary action of the soil and gravity permit water to drip from the top row to the bottom row with special cutouts (Plant Connection, 2010). Also, infusing liquid nutrients in the plants is recommended through a standard fertilizer loop (Sharp, 2007).

## Green Façades

Green façades refer to a guidance structure that provides support for vines or climbing plants to grow up the side of a wall. Most systems use wire fencing, modular trellis systems, or stainless steel cables as support systems. Wall mounted façades are either flush or 7.5-45 cm away from the wall. Green façades are attached with brackets or mounting clips and a waterproof membrane should be installed between the wall and the façade in most arrangements. When using cables or wires, turnbuckles and anchors need to be mounted and attached to each wire for possible adjustments needed as the plants grow and expand (Sharp, 2007).

Since green façades contain continuously developing plants, the support systems are essential for directional guidance and load bearing capabilities. There are three main types of support; a trellis of vertical and horizontal elements, just vertical supports, or just horizontal supports. Each system can be made of different materials like wire or wood. Different types of supports are used for different kinds of plants, and there are four main types of climbing plants; self-clinging climbers, vines-climbing plants, leaf-twining climbers & tendril climbers, and ramblers & scrambling plants (Stainless Steel Solutions, "Planting Advice" 2009).

When climbing plants are utilized for high vertical landscaping in green façades, intense weather is a common dilemma; therefore, resilient types of plants should be chosen. Depending on the area, climbers with a high tolerance for frost, wind, or heat should be selected. In addition to planning for the right type of plant, considerations must also be made for a proper schedule. Some climbers may take up to 3-5 years to completely cover the entire area, depending on the height (Sharp, 2007).



**Table 15: Types of Climbing Plants**

Name	Description	Examples	Considerations	Source
<p>Self-clinging Climbers</p> <p>(Adhesive Pad Climbers and Clinging Wall Climbers)</p>	<p>Both use lateral shoots with glandular discs that adhere to any surface and have strong roots that grow over long distances without any auxiliary support.</p>	<p>Boston Ivy <i>Parthenocissus tricuspidata</i></p> <p>Climbing Hydrangeas <i>Hydrangea petiolaris</i></p>	<p>May cause harm to buildings by damaging sidings and mortar with their invasive adhesive pads and roots, so they should only be used with a support system and proper maintenance to avoid structural damage</p>	<p>Bell, 2008</p>
<p>Vine Climbers</p>	<p>A strong affinity to grow upwards by winding around the support with circular movements of their stem tips. Slow to moderate growers need support space of 200-400 mm, and very vigorous species can be up to 800 mm apart.</p>	<p>Wisteria <i>Wisteria Sinensis</i></p> <p>Honeysuckles <i>Lonicera</i></p> <p>Hops <i>Humulus Lupulu</i></p> <p>Morning glory <i>Ipomoea Hederacea</i></p>	<p>Vertical supports might be needed in most cases, but spacing between vertical supports varies depending on the species.</p>	<p>Stainless Steel Solutions, "Planting Advice" 2009</p>

<p>Leaf-twining and Tendril Climbers</p>	<p>Use their leaves to hold on. Primarily deciduous, but they hold on to the system with their brittle stems in the winter. Slow to moderate climbers need a grid size of 150x200mm, and vigorous climbers need a grid size of 300x500mm.</p>	<p>Clematis and Nasturtiums <i>Tropaeolum</i></p> <p>Passion flowers <i>Passiflora</i></p> <p>Grape vines <i>Vitis</i></p> <p>Ampelopsis <i>Ampelopsis</i> <i>Brevipedunculata</i></p>	<p>Vertical and horizontal supports recommended for leaf-twiners and tendrils.</p>	<p>Stainless Steel Solutions, "Planting Advice" 2009</p> <p>Bell, 2008</p>
<p>Ramblers and Scrambling Plants</p>	<p>Holds on to the supports with thorns, bristles, and prickles. Can be used over stretches of horizontal growth with a small vertical range. Horizontal supports are ideal, and optimum vertical spacing is roughly 400mm.</p>	<p>Rosa Constance Spry</p>	<p>Should not be used where people can easily come into contact with them because they are so jagged. Not ideal for vertical growth.</p>	<p>Stainless Steel Solutions, "Plant Advice" 2009</p>

## Living Walls

Living walls are walls, indoors and outdoors, composed of individual planting cells attached to a supporting panel system. Panels typically hold 12 to 19 planting cells and are approximately 40 cm high by 40 cm wide. (ELT Living Walls, 2010 & Gavin, 2009). Plants are typically grown horizontally at first. The maturity of the roots increases the soil volume so it pushes against the planting cells, which aids to keep them in place when turned vertically. After a few weeks to a few months, the plants have rooted to the planting cells and are secure in their panels (Plant Connection, 2010).



**Figure 10: Living Billboard (Laumer, 2009)**

Luckily, mounting systems for interior and exterior living walls are generally the same. The panels are usually hung on a bracket system that can attach to most surfaces. A waterproof membrane should be attached behind the mounting brackets and in front of the structural wall, especially on indoor systems. The green wall panels should not touch the structural wall in order to allow adequate air flow that prevents condensation on the back of the panels. Typically, panels are not stacked or

interlocked. Instead, each panel is hung individually and can be hung next to each other to cover a wall (Plant Connection, 2010). When crops are in the planting cells, it is uncommon for the panel to be above six feet high. This allows for easier care by working in an upright standing position (Irwin, 2008).

A large array of plants can be used for living walls. Proper vegetation is typically selected based upon resilience, site-specific environmental situations, rooting system, color, breeding rate, and texture. Living wall panels can also harvest small shrubs, perennials, edible plants, ferns, and ground covers. Most living walls need to be pre-grown in order to ensure the quality of the product. Pre-grown panels need about 6 to 12 months of lead time before being installed. An automatic drip irrigation system should be put in at least a month before panel installation. With the entire site prepared, roughly 500 sf of panels can be installed in one day (Sharp – 2007).

### *Common Indoor Plants*

- Dracaena Janet Craig
- Dracaena Sanderiana
- Button Fern
- Green Prayer Plant
- Red Prayer Plant
- Croton Petra
- Croton Norma
- Peperomia Magnoliifolia
- Peperomia Orba
- Spider Plant
- Dracaena Marginata
- African Violet

(ELT Living Walls, 2010)

### *Common Outdoor Plants*

- Sedum Reflexum
- Sedum Sarmentosum
- Black Mondo Grass
- Liriope
- Hedera Helix
- Basil
- Thyme
- Mint
- Parsley
- Lettuce
- Onions
- Radishes

## ***Potential Benefits***

- Removes over 80% of Volatile Organic Compounds (VOCs) and can remove other harmful toxins, like Benzene, Formaldehyde and Trichloroethylene, by filtering the air to prevent “Sick Building Syndrome” (Plant Connection, 2010 & Irwin, 2009 & Irwin, 2008)
- Plant life offsets carbon emissions by respiration: in taking carbon dioxide and emitting oxygen (Plant Connection, 2010)
- Insulates and cools building envelope (Plant Connection, 2010)
- Aids in sound absorption (Plant Connection, 2010)
- Acts as a privacy screen (Stainless Steel Solutions, “Benefits” 2009)
- Gains LEED points from USGBC (Sharp, 2007 )
- Living walls can grow food such as strawberries, carrots, and peppers (Capital Regional District, 2010 & Irwin, 2008).
- Helps conserve energy by insulating building against heat exchange with the outside air (Capital Regional District, 2010)
- Increased greenery reduces canopy level Urban Heat Island (UHI), where manmade surfaces in an urban environment absorb sunlight, raising their temperature and the temperature of the surrounding air (Irwin, 2009)
- Used for marketing by creating a strong visual impact and also by appealing to smell and touch (Irwin, 2008)
- Positive mental health impacts by decreasing in employee stress, ailments, and absenteeism (Faculty of Applied Science, 2010)
- Protects the architectural wall from acid rain, UV light and wind (Stainless Steel Solutions, “Benefits” 2009 )
- Living walls produce comparable results to green roofs at a depth of 3 inches (Irwin, 2008).
- Supplies nesting habitat and food for birds (Capital Regional District, 2010)
- Ascetically pleasing (Irwin, 2009)

- Stormwater retention can be designed for using green walls, much like green roofs. The green walls can retain the precipitation by using the soil or a cistern to aid its water supply (Capital Regional District, 2010).

### ***Potential Risks and Considerations***

- Needs to be taken care of like normal plants with watering, pruning, deadheading, etc. (Plant Connection, 2010)
- Large areas and heights could pose a problem because of limited access (Capital Regional District, 2010).
- Shoots could penetrate between materials in the building (for example under tiles, cladding or roofs), compromising their structural integrity. This growth must to be reduced to make certain the façade will not interfere with the structural soundness of the building (Irwin, 2008).
- Without proper air and water flow, molding could occur (Capital Regional District, 2010)
- Pollen generation should be planned for (especially indoors) (Capital Regional District, 2010).
- Some systems require additional energy and money for false light and water pumps, and nutrients (Capital Regional District, 2010).

### ***Estimated Costs***

For interior and exterior systems, the cost per square foot roughly ranges from US \$100.00 to \$175.00 depending upon the arrangement and the plant material (Irwin, 2009 & Sheen, 2009 & Green Roofs for Healthy Cities, 2009).

Additional costs, such as lighting fixtures and irrigation systems, typically vary with each project. Consultation fees and labor charges typically range from US \$55.00 - \$100.00 per hour per person, but they are very dependant on the project type and location (Greenwall Australia, 2009).

### ***Recommended Site Characteristics***

Since green walls can hold almost any type of plant, the best growing conditions are based on what types of plants are used or what type of outcome is desired. Different types of plants require different amounts of water, sunlight, nutrients, and climates in order to thrive, and different desired outcomes require different variations of green walls in order to produce the best benefits.

- The greatest amount of air filtration will occur in places that need it the most, like in office building or in urban areas.
  - Indoor air quality that contains pollutants can cause many health problems and is referred to as “sick building syndrome”. A green wall indoors aids in reducing VOS's that are believed to be directly linked to sick building syndrome (Irwin, 2008).
  - Poor exterior air quality is directly related to urban heat island effect, so introducing plants to urban areas would reduce smog and air born particulates (Irwin, 2008).
- If the green wall is being used as edible garden, then the vicinities need the recommended amount of sunlight.
  - Edible gardens must be in appropriate climates to the types of vegetation being grown. For example, carrots can survive moderate to warm climates; while lettuce will do best in cooler climates with a large amount of rain (Vegetable Garden Guide, 2010).



- Insulation and energy savings with green walls is possible in warm and cold climates.
  - In cold climates, a thick layer of vegetation is recommended in order to provide insulation and wind resistance to result in higher energy savings (Bass, 2007).
  - For warm climates, green walls can be thinner because they mainly provide shade that can decrease the temperature by up to 15 degrees Celsius. In turn, energy is saved by not needing to use air conditioning (Saeki, 2009).

### ***Potential LEED Credits***

- Sustainable Sites Credit 7.1: Landscape Design That Reduces Urban Heat Islands, Non-Roof (1 point) Exterior green walls reduce the solar reflectance of a structure, thus reducing the urban heat island effect.
- Water Efficiency Credits 1.1, 1.2: Water Efficient Landscaping (1 to 2 points) Buildings can incorporate a stormwater collection system for irrigation of the green walls and other landscape features. Using only captured, recycled, or nonpotable water may enable the project to achieve this credit.
- Water Efficiency Credit 2: Innovative Wastewater Technologies (1 point) Green walls can be utilized as wastewater treatment media. Other features, such as the incorporation of compost tea from a composting toilet, are another way for green walls to aid in the reduction of wastewater.
- Energy and Atmosphere Credit 1: Optimize Energy Performance (1 to 10 points) Green walls can provide additional insulation and natural cooling, which reduces a building's reliance on mechanical systems.
- Innovation in Design Credits 1-4: Innovation in Design (1 to 4 points) Green walls may contribute to innovative wastewater or ventilation systems. (Sharp, 2007)

## ***Relevant Stantec Projects***

### **1. Edith Green Wendall Wyatt Federal Building**

Location: Portland, Oregon, USA

Description: Stantec acted as the mechanical engineer for this 18-story office building. In addition to many other improvements, a living-green-wall system was installed on the northwest wall to assist in heating, cooling, and air filtration.

Link: [http://marketingexcellence/projectprofile\\_preview.aspx?id=10&project=10537](http://marketingexcellence/projectprofile_preview.aspx?id=10&project=10537)

### **2. Rose Tree Place**

Location: Upper Providence Township, Pennsylvania, USA

Description: Stantec provided landscaping, planning, surveying, and civil engineering services for the 38,375 square foot assisted living community. The many retaining walls used have honeycomb cells, which allow the option to have plants inside the cells creating an outdoor living wall.

Link: [http://marketingexcellence/projectprofile\\_preview.aspx?id=10&project=13754](http://marketingexcellence/projectprofile_preview.aspx?id=10&project=13754)

## Sources

1. Bass, Brad. "Green Roofs and Green Walls: Potential Energy Savings in the Winter" 2007. Accessed Feb. 11 2010. <http://www.upea.com/pdf/greenroofs.pdf>

*It reviews the outcomes from testing green roofs and green walls for prospective energy conservation during winter months.*

2. Beaulieu, David. "Deadhead" 2009. Accessed Jan 28, 2010. <http://landscaping.about.com/od/landscapingdictionary/g/deadhead.htm>

*This provides information about proper deadheading techniques.*

3. Bell, Ellen. "Climbing Plants – Five Types of Climbers to Know" 2008. Accessed Jan. 26 2010. <http://www.buzzle.com/articles/climbing-plants-five-types-of-climbers-to-know.html>

*This site discusses the different types of climbing plants and how they function.*

4. Capital Regional District. "What is a Living Wall?" Copyright 1996-2010. Accessed Jan. 27 2010. <http://www.crd.bc.ca/watersheds/lid/walls.htm>

*It defines different varieties of green walls and potential advantages of them.*

5. Chad. "Green Façade Ideas for South Facing Walls" March 28 2008. 100k House. Accessed Jan. 25 2010.

<http://www.100khouse.com/2008/03/28/green-facade-ideas-for-south-facing-walls/>

*This site talks about different techniques to hang a green wall.*

6. Econoplas. "Green Walls/Facades" 2007. Accessed Feb. 25 2010.  
[http://www.econoplas.co.uk/cec\\_greenfacades.htm](http://www.econoplas.co.uk/cec_greenfacades.htm)

*Photo Source.*

7. ELT Living Walls. "Living Wall Planting Ideas" 2010. Accessed Jan 26, 2010.  
[http://www.eltlivingwalls.com/planting\\_ideas.php](http://www.eltlivingwalls.com/planting_ideas.php)

*Here is a company's professional opinion on the best plants and planters for living wall systems.*

8. Faculty of Applied Science. "Successes of Green Walls" Copyright 2001-2010. Queen's University. Accessed Jan. 27 2010.  
[http://appsci.queensu.ca/ilc/greenBuilding/greenwall/greenwall\\_05.php](http://appsci.queensu.ca/ilc/greenBuilding/greenwall/greenwall_05.php)

*This site discusses the positive mental health effects associated with green walls.*

9. Gavin. "Green Wall Panels" 2009. Accessed Jan. 28 2010.  
<http://www.livingwallart.com/living-walls/green-wall-panels/>

*It provides some dimensions on green wall panels.*

10. Green Roofs for Healthy Cities. "2008 Awards of Excellence: Vancouver Aquarium – Green Wall Design" 2009. Accessed Jan. 28 2010.

[http://www.greenroofs.org/  
index.php?option=com\\_content&task=view&id=1036&Itemid=136](http://www.greenroofs.org/index.php?option=com_content&task=view&id=1036&Itemid=136)

*Here provides information about approximate costs for green walls.*

11. Greenwall Australia Pty Ltd. "What is a Greenwall?" 2009. Accessed on Jan. 26 2010.

[http://www.greenwallaustralia.com.au/downloads/greenwall\\_info\\_pack\\_08a.pdf](http://www.greenwallaustralia.com.au/downloads/greenwall_info_pack_08a.pdf)

*This site gives additional information about cost estimates for green walls.*

12. Iannotti, Marie. "Why Should You Be Cleaning the Leaves of Houseplants" 2010. Accessed Jan. 27 2010.

[http://gardening.about.com/od/tipsforbetterhouseplants/a/Clean\\_Houseplan.htm](http://gardening.about.com/od/tipsforbetterhouseplants/a/Clean_Houseplan.htm)

*This site gives some data about indoor plant maintenance.*

13. Irwin, George. "The Green Wall Column" 2008 & 2009. Accessed Jan. 26 2010.

[http://www.greenroofs.com/archives/green\\_walls.htm](http://www.greenroofs.com/archives/green_walls.htm)

*A whole assortment of information is given on this site about green walls.*

14. Laumer, John. "Trend Watch: 'Green Wrap' Virus Spreading as Major Bank Turns Plant Wall into Billboard" 2009. Accessed Feb. 25 2010.

<http://www.treehugger.com/files/2009/09/green-wrap-virus-spreading-bank-plant-billboard.php>

*Photo Source.*

15. Plant Connection, Inc. "How the Green Wall Works" 2010. Accessed Jan. 25 2010. Available at <http://www.myplantconnection.com/>

*Irrigation, orientation, and benefits are given about green walls on this site.*

16. Saeki, Claire. "Green Walls Reduce Temperatures at Kyocera Factories Across" 2009. Accessed on Feb. 11 2010. <http://www.rfpmagazine.com/Editors-Choice/kyocera-green-wall.html>

*It gives information about site design for green walls.*

17. Science for Global Insight. "Current Economic Growth Will Intensify Air Quality Problems Unless Current Pollution Control Laws Are Significantly Upgraded" 2010. Accessed Feb. 25 2010. <http://gains.iiasa.ac.at/index.php/gains-asia/296-p6>

*Simple overview of the growing air quality issues.*

18. Sharp, Randy. "6 Things You Need to Know About Green Walls" 2007. Building Design & Construction. Accessed Jan. 27 2010. [http://www.bdcnetwork.com/article/379033-6 Things You Need to Know About Green Walls.php](http://www.bdcnetwork.com/article/379033-6_Things_You_Need_to_Know_About_Green_Walls.php)

*This provides technical data about green walls and the supporting structures.*

19. Sheen, David. "Green Wall or Green Wash?" 2009. Accessed Jan. 27 2010.  
<http://greenapple.ca/blog/2009/10/29/green-wall-or-green-wash/>

*Additional information about the cost of green walls is provided here.*

20. Smith, S.E. "What are Green Walls?" 2010. Accessed Jan. 25 2010.  
<http://www.wisegeek.com/what-are-green-walls.htm>

*This site provides standard background information and a basic overview.*

21. Stainless Steel Solutions. "Considerations for Green Wall trellis systems and loading: wind, snow, rain" 2009. Accessed Jan. 26 2010.  
<http://www.s3i.co.uk/greenfacadeloading.php>

*It gives some technical data about loading on the green wall structure.*

22. Stainless Steel Solutions. "Planting advice on Green Walls & Façades" 2009.  
Accessed Jan. 26 2010. <http://www.s3i.co.uk/facadeplantingadvice.php>

*This site offers data about different varieties of climbing plants for green facades.*

23. Stainless Steel Solutions. "What are the benefits of green walling" 2009.  
Accessed Jan. 26 2010. <http://www.s3i.co.uk/whygogreen.php>

*Environmental and financial benefits of green walls are given here.*

24. The Author. "Greenworks Mobile Green Wall: The Green Building Everyone Wants" 2009. Accessed Feb. 25 2010.

<http://www.sincerelysustainable.com/products/green-building/greenworks-mobile-green-wall-the-green-bling-everyone-wants>

*Brief background information on green walls.*

25. Time Magazine. "The 50 Best Inventions of 2009" 2009. Accessed Jan. 27 2010.

<http://www.time.com/time/specials/packages/completelist/0,29569,1934027,00.html>

*This link simply provides the Time Magazine list of 50 Best Inventions in 2009.*

26. Vegetable Garden Guide. "Your One-stop Guide to Growing Luscious Veg at Home" 2010. Accessed Feb. 11 2010. Available at <http://www.vegetable-garden-guide.com/>

*Facts about climate and care for different types of vegetation are provided here.*



## Permeable Pavements

According to a 2008 presentation by the California Asphalt Pavement Association (CAPA), porous asphalt mixes were developed by state Departments of Transportation (DOTs) in the 1930s and 1940s (Milar, 2008). According to the National Asphalt Pavement Association (NAPA), the concept of permeable pavement was proposed in the late 1960s. A 2008 presentation from Cahill Associates Environmental Consultants credits the Franklin Institute with the development of porous asphalt concrete pavement in 1972. Despite this discrepancy it is widely accepted that the intent was to “promote percolation, reduce storm sewer loads, reduce floods, raise water tables, and replenish aquifers” (NAPA, 2008). All three sources agree that it wasn’t until the 1970’s that porous pavements were used to reduce stormwater run-off; and with the development of geotextiles (a synthetic fabric used in permeable pavement systems) in 1979, the porous pavement systems used today were not developed until the early 1980s.

The new technology was implemented into projects only after the concept gained acceptance by the US Environmental Protection Agency (EPA) in the 1970s. At this time the EPA contracted to “determine the capabilities of several types of porous pavements for urban runoff control, in terms of cost and efficiency” (NAPA, 2008). Delaware, Pennsylvania, and Texas were among the first states to incorporate porous pavements and according to Cahill Associates Environmental Consultants (CAEC), a leader in the design and installation of porous pavement, there are currently over 20 states with porous pavement projects (Wible, 2008). The map shown in Figure 11 shows the states which have porous pavement projects as of 2008.

The environmental concerns which sparked the idea of porous pavement are still very prominent today. As more land becomes developed and impervious surfaces continue to cover native soils, stormwater run-off volumes are increasing while its quality is decreasing. This has many negative environmental affects which are described in a later section. Due to this, Low Impact Development strategies have been heavily promoted and porous pavements play a major role under this component of sustainable development. While porous pavements have a very promising potential in

regards to mitigating the effects of impervious cover, this technology is still relatively new and its major deterrent is the lack of data collection on its long-term performance and efficiency. Engineers are encouraged to consider the possibility of designing porous pavements with the ability to serve as case studies and research projects in which appropriate measures are taken in order to determine how well these systems can retain, infiltrate, and treat stormwater run-off. This will provide evidence-based knowledge which will lead to the growth of the porous pavement industry, further improving the technology while dramatically lowering costs. The following summarizes the cost ranges and potential benefits of both porous asphalt and porous concrete pavements.

#### Asphalt

- 1.5 times greater than impervious asphalt
- US \$5.00 - \$7.00 per square foot
- US \$2,300.00 – \$3,300.00 per parking space

#### Concrete:

- 1.8 times greater than impervious concrete
- US \$2.00 - \$11.40 per square foot

#### Benefits:

- Stormwater run-off volume reduction
- Increased stormwater run-off quality
- Increased groundwater recharge



**Figure 11: States with Porous Pavement (Wible, 2008)**

Traditionally, the development of land has led to impervious surfaces which interrupt the natural water cycle. The majority of impervious surface area can be attributed to roads and parking lots within a development (Low Impact Development Center Inc, 2007). These areas can increase peak stream flows and lead to channel incision, bank erosion, and transportation of sediment and pollution. By impeding the infiltration of rainwater into the ground, impervious surfaces also decrease ground water recharge and stream base flows (Brattebo, 2003). Many studies have documented that stream, lake, and wetland quality is reduced sharply when impervious cover in an upstream watershed is greater than 10% (EPA, 2000). Due to the negative implications of this interference the use of permeable pavements is becoming an increasingly attractive alternative. Permeable pavements can be used as an effective means of reducing the percent of impervious area in a drainage basin.

Permeable pavement is essentially a porous surface which allows water to infiltrate into an underlying stone reservoir. This reservoir acts as a temporary storage and treatment facility before the water reaches existing soil. As shown by Figure 12, water is able to seep through a concrete surface while being evenly distributed throughout a larger area at the bottom. Permeable pavements can be constructed from permeable asphalt or concrete and can range from partial to full infiltration depending on soil permeability (NAHB Research Center). By replicating the water retention and detention characteristics of pre-development conditions permeable pavements strongly mitigate the adverse effects of development on storm water run-off and help promote ground water recharge (Kloss, 2006). With proper installation and maintenance porous paving can infiltrate up to 80% of annual runoff volume. Studies have indicated that porous paving systems can also remove between 65 and 85% of undissolved nutrients and 95% of sediment from runoff (Dauphin County Conservation District (DCCD)). Although all types of permeable pavement systems can be incorporated into different designs, their unique characteristics make each of them especially applicable to certain projects. For example, the level of infiltration is heavily determined by the existing soil conditions. According to the Greater Vancouver Regional District, full infiltration is intended for sites with subsoil permeability greater than 15mm/hr, partial infiltration is designed for sites with subsoil permeability between 1 and 15mm/hr, and partial infiltration with a flow restrictor is suitable for sites with subsoil permeability less than 1mm/hr.



**Figure 12: Porous Concrete Sample (TecEco)**

### ***Permeable Asphalt***

Porous and impervious asphalts are made and look very similar to each other. Figure 13 shows how similarly both may appear until a rain-fall event. The asphalts' permeability is attained through a change in the aggregate make-up of the asphalt. In order to gain permeability small stones and fine particulate matter are removed from the formula and tar quantities are reduced. By eliminating the smaller aggregates the asphalt will have more void spaces which allow water to pass through. Eliminating the fine aggregate creates a minimum of 16% void space within the porous asphalt compared to 2-3% for impervious asphalt (Iowa's Stormwater Management Manual, 2009). This may reduce overall strength of the pavement and must be taken into consideration when the pavement is designed.



**Figure 13: Permeable vs. Impervious Asphalt (Adams, 2003)**

Although the porous asphalt allows water to seep through (virtually eliminating run-off) it is only the first layer within a 5-layer system that is designed to filter and slowly release run-off into native soils. Beneath the roughly 3 inch surface lies the stone bed which comprises the remaining 4 layers. The stone bed size and depth must be designed so that the water level never rises into the asphalt. According to Iowa's Storm Management Manual (ISMM, 2009) the stone bed consists of a top filter base course of open graded aggregate, an aggregate subbase layer for water storage and structural support, and a geotextile filter fabric directly above an uncompacted layer of soil.

The second layer of a permeable asphalt system, also the first component of the stone bed, is made of open graded aggregate and is used as a filter base layer to provide a uniform and compact surface for pouring of the permeable asphalt. The open graded aggregate also serves as an additional filter (after the surface layer) for large particles. "Open graded" refers to the small proportion of fine particles used in the aggregate mix (WAPA, 2002). A typical thickness for this upper filter layer is 2 to 4 inches (ISMM, 2009).

The second aggregate layer is a subbase reservoir layer. This layer serves as temporary water storage and structural support. The minimum thickness of this layer depends on the type of subgrade soils, the design subgrade infiltration rate, and the minimum depth required for the storage of the design storm event. According to the

University of New Hampshire's Storm Water Center this layer is usually about 24 inches.

The non-woven geotextile fabric layer (synthetic fabric typically used in erosion control) separates the subbase reservoir layer from the soil. This layer serves two main purposes. It prevents the soil from becoming contaminated while preventing the migration of fine particles into the subbase reservoir layer which could clog the system (ISMM, 2007). The treated water then percolates through the final layer of uncompacted soil and into the ground water. Figure 14 shows an overall diagram of these layers.

### *Porous Asphalt*

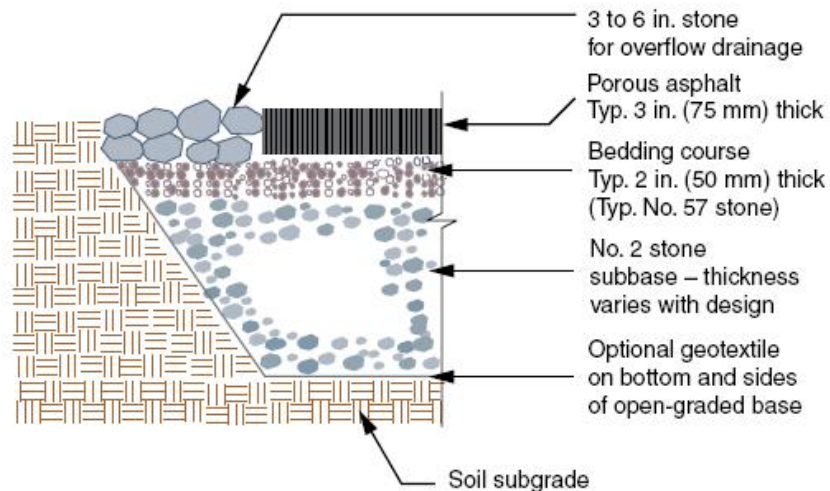

**Figure 14: Porous Asphalt System (Smart Planet, 2009)**

### **Potential Benefits**

The environmental benefits of porous asphalt as well as other pervious pavements are all linked to the proper management of storm-water run-off. Run-off management usually refers to both volume control and water quality which when properly managed creates a number of environmental benefits. Porous pavements filter out many of the contaminants carried in stormwater run-off, protecting soils and

groundwater from contamination. By treating run-off, porous asphalts are able to protect water supply sources. This alone has many repercussions including the stability of downstream ecosystems. Since porous asphalt is also able to retain run-off, volume levels are controlled. By reducing run-off volume the load on sewer systems and the possibility of erosion and flooding are all reduced.

Other benefits of porous pavements include the reduction of the heat island effect as well as the reduction of many water-related driving issues. Since the permeable pavement allows for the exchange of air and moisture into the pavement, porous surfaces remain at cooler temperatures (EPA Cool Pavements, 2005). This helps alleviate the phenomenon known as the heat island effect in heavily urbanized areas. Furthermore, due to the quick draining structure of permeable pavements, water related driving issues are reduced. These include high skid resistance, low noise, and fewer puddles are all benefits of porous asphalt. Also, if designed properly, the deep structural support of porous asphalt pavements can result in fewer cracks and potholes than in conventional asphalt pavement (EPA, 2009).

- According to the EPA's site on porous asphalt pavement, a porous asphalt street in France was able to retain 96.7% of run-off volume.
- A parking lot in Durham, NH was able to retain 25% of run-off volume. The Durham parking lot was also able to remove 99% of the total suspended solids, 97% of zinc, and 42% of the total phosphorous in run-off in 2004 (EPA, 2009).

## **Potential Risks and Considerations**

According to the Dauphin County Conservation District (DCCD), the following design factors need to be taken into account to ensure optimum pollutant removal and longevity:

- Placement in areas with highly permeable soils will allow better infiltration



- Existence of organic material in soil allows microorganisms to eliminate certain nutrients/pollutants
- Vacuum sweeping on a quarterly schedule will reduce the possibility of clogging
- Use in low-density parking areas will ensure that the pavement system can withstand daily vehicle loads
- Use in low-density parking areas will reduce the amount of pollutants which will enter the pavement system
- Restrictions on use by heavy vehicles prevents rutting/cracking due to excessive loads
- Limited use of de-icing chemicals will prevent the system from clogging
- Implementation of a sediment control plan reduces the possibility of clogging from fine soils
- Extending the depth of reservoir level to below the frost line to protect the subgrade from frost heaves.

In addition to these design considerations, one of the greatest risks associated with permeable pavements is the possible contamination of groundwater. In areas with high water tables and/or contaminated soils this risk is maximized. Proper design, installation, and maintenance must be carried out to reduce this risk. Adequate space between the high water table and the bottom of the pavement system as well as the use of proper materials such as the geo-textile fabric are crucial to implementing these systems in risky areas.

## **Estimated Costs**

According to the National Cooperative Highway Research Program (NCHRP), the cost of porous asphalt material is about US \$1.00 per square foot; this is roughly equal to that of impervious asphalt. However, the initial cost of the whole pavement system is typically about 20% higher than that of impervious asphalt. This is because the layers

under the permeable pavement are more expensive than the conventional compacted subbase layers (Adams, 2003). This added cost can be mitigated by the elimination or reduction of traditional stormwater management systems that permeable pavements allow. According to the EPA, impervious asphalt lots with stormwater systems can cost as much as US \$10.00 per square foot and the installation of permeable asphalt lot can be as low as US \$5.00 to US \$7.00 per square foot. The following is EPA's list of factors which influence the overall cost of a porous asphalt system.

- Material availability and transport - The ease of obtaining construction materials and the time and distance for delivery.
- Site conditions - Accessibility by construction equipment, slope of the site, and existing buildings and uses.
- Subgrade - Subgrade soils such as clay may result in additional base material needed for structural support or added stormwater storage volume.
- Stormwater management requirements - The level of control required for the volume, rate, or quality of stormwater discharges will impact the volume of treatment needed.
- Project size - Larger porous asphalt areas tend to have lower per square foot costs due to construction efficiencies.

The following is a list of permeable pavement projects and their costs:

- In 2004, the University of New Hampshire has estimated that porous pavements cost an average of US\$2,300.00 per parking space compared to US\$2,000.00 per parking space for traditional asphalt (UNH, Porous Asphalt)
- According to Metro Watershed Partners current permeable pavement projects have had an average cost between \$2,200 and \$2,750 per parking space for parking, aisles, and stormwater management (Cahill, 2003).
- A porous asphalt parking lot project at the University of Rhode Island cost US \$3,337 per parking space (McNally, 2002). This cost included operational/maintenance costs which were crucial to system's effectiveness.

## Recommended Site Characteristics

All permeable pavements are recommended for areas of low traffic. Porous asphalts are applicable for applications such as parking lots, driveways, sidewalks, bike paths, playgrounds, tennis courts, and fire lanes. Due to its lower load-bearing capacity permeable asphalt should not be used in high traffic or speed areas (EPA, 2009). Given adequate maintenance (such as regular vacuuming of the surface to prevent clogging by sediment) porous asphalt can last at least 20 years (DCCD).

According to the University of New Hampshire porous concrete may be especially effective in cold climates due to its capacity to reduce the salt needed for deicing in winter conditions. Porous asphalt has been found to work well in cold climates as the rapid drainage of the surface reduces the occurrence of freezing puddles and black ice. Melting snow and ice infiltrates directly into the pavement facilitating faster melting (Gunderson, 2008). However in cases where salt is still used, clogging or groundwater contamination may become a risk. This possibility creates skepticism regarding their efficiency in cold climates among some engineers (See Stantec employee interviews).

Porous asphalt is also suitable for warmer areas because it can reduce the impacts of the heat island effect by allowing water exchange between the ground surface and the deep soil layer. According to a report on the impacts of porous asphalt on warm environments, the air and water exchange allowed by permeable asphalt “promotes evaporation which leads to a reduction of the atmospheric heating rate as well as the infrared radiation emission, which directly affects pedestrians during the hot time of the day in summer” (Asaeda, 2000).

Porous asphalt is most applicable to sites with gentle slopes (less than 5%), permeable soils, and relatively deep water tables and bedrock levels. Any variation of these parameters will alter the design of the porous pavement system and potentially affect the cost and performance of the asphalt. Sites near a stormwater hotspot such as gas stations should take additional measures to ensure that the porous asphalt doesn't allow heavily polluted runoff from entering ground water.

## ***Permeable Concrete***

Porous concrete is a mix of Portland cement, uniform open-graded coarse aggregate, and water. In porous concrete sand is used as little as possible. Permeability is achieved by using larger pea gravel, a lower water-to-cement ratio (.27-.43), and very little sand compared to normal concrete. This mix allows the concrete to attain between 15% and 30% void space while impervious concrete usually has void space between 3% and 5% (Huffman, 2005). According to the National Ready Mixed Concrete Association (NRMCA), concrete with voids between 15% and 25% allows water to infiltrate the surface at a rate of 480 in. /hr (5 gal/ft<sup>2</sup>/ min). This value is in accordance with the Portland Cement Association (PCA) which states that permeable concrete allows 3-8 gallons of water per minute to pass through each square foot (PCA, “Pervious Concrete Pavements”). Figure 15 demonstrates the infiltration capacity differences between pervious concrete and conventional asphalt.



**Figure 15: Permeable Concrete vs. Conventional Asphalt (NRMCA, 2009)**

As with porous asphalt, permeable concrete is used as a single component of a layered system. As described by the DCCD, porous concrete systems consist of four

layers: a surface layer of porous concrete (2-4 inches), a filter layer of half-inch crushed aggregate (1-2 inches), a reservoir layer of one to three-inch aggregate (at least 12 inches), and a layer of filter fabric. While these types of layered systems are typical for all porous concrete projects they can be further grouped into detention or retention systems. Detention systems capture water in an underlying aggregate base until it is transported to an existing drainage/sewerage system and retention systems retain stormwater in the pervious concrete and aggregate base until it percolates into the underlying soil. The design of both systems strongly depends on the permeability of the existing soil (Tyner, 2009).

## **Potential Benefits**

- Permeable concrete can be used as a stormwater management technique.
  - According to the EPA a residential street and sidewalk in Sultan, WA made of porous concrete is able to retain 100% of stormwater run-off.
  - In 2001, a parking lot in Kinston, NC is able to retain 99.9%. This was noteworthy because the existing soil is of clay-type which is characterized by a lack of permeability (Hunt, 2006).
  - A permeable pavement project done in 2006 in Seattle, Washington was able to infiltrate 41% of the total run-off volume
  - A permeable pavement project in Tampa, Florida's aquarium parking lot concluded that the porous pavement was able to retain 80% of the run-off volume while significantly lowering pollutants (EPA, 2000).
- Porous concrete also has the ability to filter and treat run-off.
  - According to the Norma's site on the environmental benefits of pervious concrete, hydrocarbons such as oil from vehicles that are contained within pervious concrete systems can become a food source for naturally occurring microorganisms. The NRMCA has determined that over 97.6% of oils

- introduced into pervious pavements are trapped and biodegraded (NRMCA, 2010).
- The EPA conducted a study where a porous concrete parking lot in Tampa, FL removed 91% of total suspended solids and 75%-92% of metals (EPA, 2009).
  - Permeable concrete pavements can result in the reduction of peak velocity and volume of stormwater runoff delivered to a storm sewer system.
  - Permeable concrete pavements can alleviate flooding and/or erosion downstream.
  - Permeable concrete pavements can be applied to all types of sites including residential, commercial, and industrial.
  - Permeable concrete pavements can help facilitate a gradual recharge of the groundwater supply.
  - Can reduce pollutants/contaminants in stormwater run-off protecting ground and surface water quality.
  - According to the PCA, due to its high void content pervious concrete is also lightweight, as it weighs between 1600 to 1900 kg/m<sup>3</sup> (100 to 120 lb/ft<sup>3</sup>).
  - Permeable concrete pavements can help alleviate of the heat island effect.

## **Potential Risks and Considerations**

The freeze-thaw cycles of regions with cold climates present the greatest limitation for the use of porous concrete. Due to its poor durability performance in laboratory freeze-thaw testing the use of permeable concrete in cold climates has not been recommended (Weygand, 2006). However, recent research has shown several ways of improving the pervious concrete's performance in cold climates as well as improving strength and permeability (Schaefer, 2006). According to a study conducted in 2009 at the University of Tennessee pervious concrete's durability in cold climates under freeze-thaw conditions can be improved by replacing up to 7% of the coarse

aggregate with sand polypropylene fibers and adding air entraining agents (Tyner, 2009).

Additionally, many engineers emphasize the importance of proper maintenance of these systems in order to prevent clogging. This is a possibility regardless of the climate in the given area; however deicing material used in colder climates poses the greatest risk for clogging (See Stantec employee interviews).

## **Estimated Costs**

According to the Stormwater Management Academy at the University of Florida, porous concrete initial costs are about 1.5 times higher than impervious concrete (UofF, 2008). This difference is mostly caused by the combination of the required skill for proper installation and a low-demand for the product. According to NCHRP in 2005 porous concrete costs ranged from US \$2.00 to US \$7.00 per square foot. The EPA states that costs are dependent on the difficulty of obtaining the construction materials, existing site conditions such as accessibility and slope, the permeability of subgrade soils, and the project size (EPA, 2009).

The EPA also offers the following example on how investments in the permeable concrete market can drastically lower overall costs. As stated on the EPA's site for pervious concrete pavements the City of Chicago began using pervious concrete at costs of US\$145 per cubic yard. A year after having made the initial investment in the city's pervious concrete market the price of pervious concrete dropped to ordinary concrete prices of about US \$45 per cubic yard (EPA, 2009).

In 2004 Portland, Oregon paved 4 blocks totaling 28,000 square feet of permeable pavement. Their goal was to better understand how permeable pavement manages stormwater as well as how cost-effective this type of project would be. The entire project cost US \$412,000. They concluded that using pervious pavers was about 1.8 times more costly than standard construction. This resulted in an estimated cost of \$10.50 per

square foot of permeable pavement system installed (Westmoreland Pervious Pavers, Oregon).

A project done in the Seattle, WA resulted in the following estimates (Gwilym, 2006):

A porous roadway including pavement, excavation, subbase, side barriers and underdrains cost around US \$85 to US \$165 per square yard.

Porous sidewalks including pavement, excavation, and subbase cost about \$26 to \$67 square yard.

Impervious 8" depth City Cement Concrete Roadway (including subbase and excavation) cost about \$44 to \$50 per square yard.

- Impervious City Cement Concrete Sidewalk costs about \$19 to \$30 per square yard.

A residential project in Sultan, WA Stratford Place paved 32,000 square feet of permeable concrete. According to an article on concretenetwork.com the developer's estimate for the project was US\$196,000.00 given cost savings of approximately US\$264, 000.00 due to a reduction in the following.

- Traditional storm water catch basins, embeds, and piping infrastructure, labor, saving US\$175,000
- Need for detention vaults
- Interior plat curbing, saving US\$37,000
- Asphalt roadway system, saving US\$48,000
- City/county future maintenance of roadway and storm system

Also, the builder was able to reclaim two additional lots because the area needed for detention vaults, ponds, and perimeter structures was reduced. Each lot was valued at



US\$100,000 each. A traditional stormwater system for the project was estimated at US\$460,000.00.

Table 16 was included in a presentation by Cahill Environmental Consultants in 2005. It summarizes the square foot costs for both porous asphalt and porous concrete and is based on the actual costs received by the County of San Diego (Wible, 2008).

**Table 16: Porous Pavement Costs**

PAVEMENT REPLACEMENT SQUARE FOOT COSTS 2005						
	Demolition & Excavation	Installation of Sub Base	Pavement Costs	Square Foot Costs*	Annual Est. Square Foot Maintenance Costs	Comments
Porous Asphalt	\$ 2.75	\$ 1.88	\$ 1.87	\$ 6.50	\$ 0.04	18" excavation/backfill. 3" porous asphalt.
Standard Asphalt	\$ 2.13	\$ 1.04	\$ 1.32	\$ 4.49	\$ 0.06	6"-Excavation/Backfill. 6"-Asphalt.
Porous Concrete	\$ 3.19	\$ 1.88	\$ 6.34	\$ 11.41	\$ 0.02	18"-Excavation/Backfill. 5-1/2" pervious concrete.
Standard Concrete	\$ 1.51	\$ -	\$ 3.42	\$ 4.93	\$ 0.01	No new base material. 6"-Reinforced Concrete
Porous Pavers	\$ 2.75	\$ 1.88	\$ 9.63	\$ 14.26	TBD	18"-Excavation/Backfill. 3"-Paver.

\*Square foot cost are based on actual cost received by the County of San Diego.

## Recommended Site Characteristics

Pervious concrete has a low compressive strength of 3.5 to 27.5 MPa (500 psi to 4000 psi) and a flexural strength range of about 1 to 3.5 MPa (150 to 500 psi). Therefore, pervious concrete is typically used in low-traffic areas. According to the NRMCA, pervious concrete is adequate for uses shown in the following (NRMCA, 2010).

- Low-volume pavements
- Residential roads, alleys, and driveways
- Sidewalks and pathways
- Parking areas
- Low water crossings
- Tennis courts
- Subbase for conventional concrete pavements
- Patios
- Artificial reefs
- Slope stabilization
- Well linings
- Tree grates in sidewalks
- Foundations
- Floors for greenhouses, fish hatcheries, aquatic amusement centers, and zoos
- Hydraulic structures
- Swimming pool decks
- Pavement edge drains
- Groins and seawalls
- Noise barriers
- Walls (including load-bearing)

### ***Potential LEED Credits***

The following is a list of potential LEED points that can be obtained through the use of permeable pavement.

- LEED Credit SS-C6.1 Stormwater Design - Quantity Control
- LEED Credit SS-C6.2 Stormwater Design – Quantity Control

- LEED Credit SS-C7.1 Heat Island Effect – Non-Roof
- LEED Credit WE C1.1 Water Efficient Landscaping
- LEED Credits MR-C4.1 AND MR-C4.2 Recycled Content
- LEED Credit MR-C5.1 AND MR-C5.2 Regional Materials

## ***Relevant Stantec Projects***

- 1. NAME:** **Randolph Park and Ride**  
**LOCATION:** [Randolph, Vermont](#)  
**DESCRIPTION:** A 60 to 80 spot parking lot was constructed in Vermont using special porous pavement designed to have extra voids.  
**LINK:**  
[http://marketingexcellence/projectprofile\\_preview.aspx?id=10&project=17267#](http://marketingexcellence/projectprofile_preview.aspx?id=10&project=17267#)
- 2. NAME:** **Heritage Flight Aviation Campus Expansion**  
**LOCATION:** [Burlington, Vermont](#)  
**DESCRIPTION:** An aviation facility that utilized porous concrete in its parking lot.  
**LINK:**  
[http://marketingexcellence/projectprofile\\_preview.aspx?id=10&project=17658#](http://marketingexcellence/projectprofile_preview.aspx?id=10&project=17658#)
- 3. NAME:** **Nellie Reynolds Gardens Senior Housing Project**  
**LOCATION:** [Philadelphia, Pennsylvania](#)  
**DESCRIPTION:** A 64 unit senior housing project which utilized green stormwater control in part by minimizing impermeable surfaces through the use of permeable pavement.  
**LINK:**  
[http://marketingexcellence/projectprofile\\_preview.aspx?id=10&project=14425](http://marketingexcellence/projectprofile_preview.aspx?id=10&project=14425)
- 4. NAME:** **Temple Beth Elohim**  
**LOCATION:** [Wellesley, Massachusetts](#)  
**DESCRIPTION:** A temple which will park 104 cars has implemented a porous pavement parking area which will total 26,000 square feet.  
**LINK:**  
[http://marketingexcellence/projectprofile\\_preview.aspx?id=10&project=18868](http://marketingexcellence/projectprofile_preview.aspx?id=10&project=18868)

- 5. NAME: University of Victoria Medical Sciences Building**  
LOCATION: Victoria, British Columbia  
DESCRIPTION: The project included permeable pavements, grass pave and bioswales to reduce and treat stormwater captured by the site.  
LINK: [http://marketingexcellence/projectprofile\\_preview.aspx?id=10&project=10928](http://marketingexcellence/projectprofile_preview.aspx?id=10&project=10928)
- 6. NAME: Hunter School Homeownership Project**  
LOCATION: [Philadelphia, Pennsylvania](#)  
DESCRIPTION: Due to the Philadelphia Water Department's requirements, individual on-lot infiltration beds and permeable pavement systems were designed to retain and treat the stormwater runoff.  
LINK: [http://marketingexcellence/projectprofile\\_preview.aspx?id=10&project=16286](http://marketingexcellence/projectprofile_preview.aspx?id=10&project=16286)
- 7. NAME: The Meadows in the Glen Residential Subdivision**  
LOCATION: [Georgetown, Ontario](#)  
DESCRIPTION: This low impact development project implemented strategies such as infiltration trenches, ditches instead of storm sewers, bio-swales, reduced pavement widths, permeable sidewalks, and limited tree removals.  
LINK: [http://marketingexcellence/projectprofile\\_preview.aspx?id=10&project=16286](http://marketingexcellence/projectprofile_preview.aspx?id=10&project=16286)

## Sources

1. Adams, Michele “Porous Asphalt Pavement With Recharge Beds 20 Years and Still Working”, 2003, Accessed Jan. 27, 2010. <http://www.stormh2o.com/may-june-2003/pavement-porous-bmps.aspx>

*An article about properly designing permeable pavement systems for longevity and adequate performance.*

2. Asaeda, Takashi; Thanh Cab, Vu. “Characteristics of Permeable Pavement During Hot Summer Weather and Impact on the Thermal Environment, 2000, Accessed Jan. 25, 2010

*A research paper on the ability of permeable pavements to allow thermal transfer.*

3. Ashley, Erin, “Using Pervious Concrete to Achieve LEED Points”, 2008, Accessed Feb. 1, 2010. [http://www.perviouspavement.org/benefits\\_LEEDcredit.htm](http://www.perviouspavement.org/benefits_LEEDcredit.htm)

*The National Ready Mixed Concrete Association’s informational site on permeable concrete with potential LEED benefits listed.*

4. Brattebo, Benjamin; Booth, Derek, “Long-Term Stormwater Quantity and Quality Performance of Permeable Pavement Systems”, 2003, Accessed Jan. 25, 2010. <http://www.sciencedirect.com>

*A research paper on the performance of four permeable pavement systems from the perspectives of mechanical durability, infiltration, and water quality after 6 years of daily use.*

5. Cahill, Thomas; Adams, Michele; Marm, Courtney. "Porous Asphalt: The Right Choice for Porous Pavement". 2003, Accessed Jan. 25, 2010.

<http://www.cleanwatermn.org/Documents/MS4%20toolkit%20files/Good%20Housekeeping/Porous%20Pavement/AsphaltRight%20Choice%20For%20Porous%20Pavements.pdf>

*An informational brochure on permeable asphalt written for the Metro Watershed Partners of Minnesota.*

6. Dauphin County Conservation District (DCCD) "Porous Asphalt" Accessed Jan.25, 2010.

<http://www.dauphincd.org/swm/BMPfactsheets/Porous%20Asphalt%20fact%20sheet.pdf>

*A porous asphalt fact sheet written as part of the Dauphin County, PA. conservation district's best management practices.*

7. EPA, "Porous Asphalt Pavement", 2009, Accessed Jan. 25, 2010.

<http://cfpub.epa.gov/npdes/stormwater/menuofbmps/index.cfm?action=browse&Rbutton=detail&bmp=135&minmeasure=5>

*The EPA's informational site on porous asphalt covered under the National Pollutant Discharge Elimination System site.*

8. Gunderson, J., "Pervious Pavements: New Findings About Their Functionality and Performance in Cold Climates", 2008, Accessed Jan. 25, 2010.

<http://www.stormh2o.com/september-2008/pervious-asphalt-concrete.aspx>

*An article on the performance and durability of permeable pavement in cold climates.*

9. Gwilym, Kathryn, "City of Seattle Porous Pavement Case Study", 2006, Accessed Feb. 1, 2010.

[http://www.psparchives.com/publications/our\\_work/stormwater/lid/paving\\_docs/Seattle%20Porous%20Pavement%20Case%20Study-Gwilym%202006.pdf](http://www.psparchives.com/publications/our_work/stormwater/lid/paving_docs/Seattle%20Porous%20Pavement%20Case%20Study-Gwilym%202006.pdf)

*A porous pavement case study from the city of Seattle, Washington.*

10. Greater Vancouver Regional District, "Stormwater Source Control Design Guidelines" 2005, Accessed Jan. 25, 2010.

[http://www.cuyahogariverrap.org/watershedstrategies/pervioussurface/pervious\\_paving.pdf](http://www.cuyahogariverrap.org/watershedstrategies/pervioussurface/pervious_paving.pdf)

*A design brochure on different types of infiltration levels for permeable pavements.*

11. Huffman, Dan, "Concrete Resources: Understanding Pervious Concrete", 2005, Accessed Jan. 29, 2010.

[http://www.concreteresources.net/images/graphics/CSI\\_Construction\\_Specifier\\_magazine.pdf](http://www.concreteresources.net/images/graphics/CSI_Construction_Specifier_magazine.pdf)

*An informational article on pervious concrete.*

12. Hunt, William; Bean, Eban, "NC State University Permeable Pavement Research and Changes to the State of NC Runoff Credit System", 2006, Accessed Feb. 1, 2010.

[http://www.perviouspavement.org/PDFs/ncsu\\_study.pdf](http://www.perviouspavement.org/PDFs/ncsu_study.pdf)

*An article outlining the major differences between pervious and impermeable pavements.*

13. Iowa's Storm Management Manual, "Porous Asphalt Pavement", 2009, Accessed Jan. 25, 2010. <http://www.intrans.iastate.edu/pubs/stormwater/documents/2J-3%20Porous%20Asphalt%20Pavement.pdf>

*The porous asphalt pavement section under Iowa's stormwater management manual.*

14. Judy, Richter, "When it Rains, it's Porous", 2006, Accessed Jan. 29, 2010. [http://articles.sfgate.com/2006-12-23/home-and-garden/17326943\\_1\\_water-runoff-paving-runoff-from-new-construction](http://articles.sfgate.com/2006-12-23/home-and-garden/17326943_1_water-runoff-paving-runoff-from-new-construction)

*An article on the potential future of permeable pavements resulting in a reduction in the use of impervious paving.*

15. Kloss, Christopher; Calarusse, Crystal "Rooftops to Rivers Green Strategies for Controlling Stormwater and Combined Sewer Overflows" University of Maryland School of Public Policy, 2006. Accessed Jan. 25, 2010

*The Natural Resources Defense Council's work on sustainable solutions for controlling stormwater and combined sewer overflows.*

16. [Low Impact Development Center, Inc.](http://www.lid-stormwater.net/permpavers_benefits.htm) "Urban Design Tools, Permeable pavers", 2007, Accessed Jan. 25, 2010. [http://www.lid-stormwater.net/permpavers\\_benefits.htm](http://www.lid-stormwater.net/permpavers_benefits.htm)

*The low impact development center's informational site on permeable pavements.*



17. Miler, Brandon, California Asphalt Pavement Association, "Porous Asphalt Pavements with Stone Recharge Beds", 2008, Accessed Feb. 23, 2010.

<http://www.coastal.ca.gov/nps/lid/Milar-PorousAsphaltPavements.pdf>

*Presentation on porous asphalt, including its history, application and several case studies.*

18. McNally, Catherine; Philo, Lisa; Joubert, Louraine. "A Case Study of Alternative Pavement Material" 2002, Accessed Jan. 25, 2010.

<http://www.uri.edu/ce/wq/NEMO/Publications/PDFs/PP.URICaseStudy.pdf>

*Permeable pavement case studies from the University of Rhode Island.*

19. NAHB Research Center – "Permeable Pavement Tech Specs" Accessed Jan.25, 2010. Available at

[http://www.toolbase.org/PDF/DesignGuides/PermeablePavement\\_TechSpec.pdf](http://www.toolbase.org/PDF/DesignGuides/PermeablePavement_TechSpec.pdf)

*An NAHB, Tool Base, and Partnership for Advancing Technologies in Housing fact sheet on permeable pavements.*

20. National Asphalt Pavement Association, "History", 2008, Accessed Feb. 23, 2010.

[http://www.hotmix.org/index.php?option=com\\_content&task=view&id=516&Itemid=1101](http://www.hotmix.org/index.php?option=com_content&task=view&id=516&Itemid=1101)

*An overview of the history and progression of the porous asphalt industry.*

21. National Cooperative Highway Research Program (NCHRP), "Evaluation of Best Management Practices for Highway Runoff Control: Low Impact Development Design

Manual for Highway Runoff Control”, 2005, Accessed Jan. 25, 2010.

[http://onlinepubs.trb.org/onlinepubs/nchrp/nchrp\\_rpt\\_565.pdf](http://onlinepubs.trb.org/onlinepubs/nchrp/nchrp_rpt_565.pdf)

*A research paper on the use of several techniques for managing runoff on highways.*

22. NRMCA, “Applications”, 2010, Accessed, Feb. 1, 2010,

<http://www.perviouspavement.org/applications.htm>

*The National Ready Mixed Concrete Association’s informational site on permeable concrete, specifically the suitable applications for the latter.*

23. National Ready Mixed Concrete Association, “Freeze Thaw Resistance of Pervious Concrete”, 2004. Accessed Jan. 29, 2010.

<http://www.nrmca.org/greenconcrete/nrmca%20-%20freeze%20thaw%20resistance%20of%20pervious%20concrete.pdf>

*A research paper on the durability of permeable concrete in cold climates.*

24. National Ready Mixed Concrete Association, “Pervious Concrete”, 2009. Accessed Jan. 29, 2010.

<http://www.perviouspavement.org/benefits,%20environmental.htm>

*The National Ready Mixed Concrete Association’s informational site on permeable concrete, specifically the environmental benefits of the latter.*

25. National Ready Mixed Concrete Association, “Pervious Concrete: When it Rains it Drains”, Accessed Jan. 29, 2010. Available at

<http://www.nrmca.org/aboutconcrete/When%20it%20rains%20%20it%20drains.pdf>

*An informational brochure on permeable concrete.*

26. Portland Cement Association, "Pervious Concrete Pavements", Accessed Feb. 1, 2010. <http://www.pervious.info/>

*The PCA's informational site on permeable concrete.*

27. Portland, Oregon, "Westmoreland Pervious Pavers", Accessed Feb. 1, 2010. <http://www.portlandonline.com/shared/cfm/image.cfm?id=174662>

*A permeable pavement case study in Portland, Oregon is analyzed for performance, durability, and cost effectiveness.*

28. Schaefer, V.R.; Suleiman, M.T.; Wang, K; Kevern, J.T.; Weygand, P. "An Overview of Pervious Concrete Applications in Stormwater Management and Pavement Systems", 2006, Accessed Feb. 1, 2010. <https://fp.auburn.edu/heinmic/PerviousConcrete/Stormwater%20Mngt.pdf>

*An informational article on the design and construction of pervious pavements.*

29. Schaefer, V.R.; Suleiman, M.T.; Wang, K; Kevern, J.T. "Mix Design Development for Pervious Concrete in Cold Weather Climates", 2006, Accessed Feb 1, 2010. [http://www.lehighcement.com/Sustainability/CPTC\\_Report206.pdf](http://www.lehighcement.com/Sustainability/CPTC_Report206.pdf)

*Research paper on the proper design of pervious asphalt for enhanced performance in cold climates.*

30. Smart Planet, "EPA Testing Porous Pavement to Filter Pollutants in Stormwater", 2009. <http://www.smartplanet.com/business/blog/smart-takes/epa-testing-porous-pavement-to-filter-pollutants-in-storm-water/1846/>

*Photo Source*

31. Tyner, J.S.; Wright, W.C.; Dobbs, P.A. "Increasing Exfiltration From Pervious Concrete and Temperature Monitoring." University of Tennessee 2009, Accessed Feb. 1, 2010. <http://www.secement.org/PDFs/perv%20concrete.pdf>

*A research paper on the exfiltration and retention capabilities of pervious concrete.*

32. TecEco Pty. Ltd. "Permeconcrete" <http://www.tececo.com/technical.permecocrete.php>

*Photo Source*

33. University of Florida, "Permeable Surfaces", 2008, Accessed Jan. 25, 2010. [http://buildgreen.ufl.edu/Fact\\_sheet\\_Permeable\\_Surfaces.pdf](http://buildgreen.ufl.edu/Fact_sheet_Permeable_Surfaces.pdf)

*The University of Florida's Program for Resource Efficient Communities' fact sheet on permeable pavements.*

34. University of New Hampshire, "Porous Asphalt", Accessed Feb. 1, 2010. [http://www.unh.edu/erg/cstev/fact\\_sheets/pa\\_fact\\_sheet\\_08.pdf](http://www.unh.edu/erg/cstev/fact_sheets/pa_fact_sheet_08.pdf)

*The University of New Hampshire's fact sheet on porous asphalt.*

35. Wanielista, Marty; Chopra, Manoj, "Performance Assessment of Portland Cement Pervious Pavement", 2007, Accessed Feb. 1, 2010, Available at [http://www.dot.state.fl.us/research-center/Completed\\_Proj/Summary\\_RD/FDOT\\_BD521\\_02\\_rpt4.pdf](http://www.dot.state.fl.us/research-center/Completed_Proj/Summary_RD/FDOT_BD521_02_rpt4.pdf)

*A research paper on the performance of a pervious pavement project constructed in Florida.*

36. Wible, Daniel, Cahill Associates Environmental Consultants, "Porous Pavement/Groundwater Recharge", 2008, Accessed Feb. 23, 2010. [http://www.projectcleanwater.org/pdf/lid/Permeable\\_Pavements.pdf](http://www.projectcleanwater.org/pdf/lid/Permeable_Pavements.pdf)

*Presentation on porous pavement including its history and several case studies.*

37. Wong, Eva, "Reducing Urban Heat Islands: Compendium of Strategies Cool Pavements", 2005, Accessed Jan. 25, 2010. <http://www.epa.gov/hiri/resources/pdf/CoolPavesCompendium.pdf>

*A research paper on the ability of permeable pavements to mitigate the heat-island effect.*

38. Washington Asphalt Pavement Association (WAPA), "Aggregate", 2002, Accessed Feb. 1, 2010. [http://www.asphaltwa.com/wapa\\_web/modules/03\\_materials/03\\_aggregate.htm](http://www.asphaltwa.com/wapa_web/modules/03_materials/03_aggregate.htm)

*The Washington Asphalt Pavement Associations informational site on pervious asphalt.*

39. Yang, Jing; Jiang, Gouling. "Experimental Study on Properties of Pervious Concrete Pavement Materials" August, 2002. Accessed Jan. 25, 2010

*A research paper on how altering the design mix of the permeable concrete can affect its durability and performance.*

## Stormwater Run-off Infiltration Systems

Stormwater run-off infiltration systems such as bioretention areas and vegetated swales are stormwater management tools promoted by Low-Impact Development (LID). LID practices began in the mid 1980s in Prince George's County (PGC), Maryland. They were pioneered to help PGC “address the growing economic and environmental limitations of conventional stormwater management practices” (LID, 2007). Bioretention technology was the first LID practice introduced and it intended to help control stormwater pollutants, reduce runoff volume, and manage runoff timing. Its use was further encouraged when the U.S. Environmental Protection Agency (EPA) developed national stormwater regulations as part of their National Pollutant Discharge Elimination System (NPDES) stormwater program. The most recent of which is the 1999 Phase II Stormwater Permit Rule. This rule requires that all operators of Municipal Separate Storm Sewer Systems (MS4s) in census-defined urbanized areas as well as construction sites of 1 to 5 acres have a NPDES permit for stormwater discharge. This effort aimed to preserve, protect, and improve the Nation’s water resources by encouraging the implementation of programs and practices that would control polluted stormwater runoff (EPA, 2000).

Other regulations which do not apply to the entire nation have also been developed in order to better target specific problem areas. The most recent regulation of this type is the Energy Independence and Security Act of 2007. This “requires all federal development and redevelopment projects with a footprint above 5,000 square feet to achieve predevelopment hydrology to the maximum extent technically feasible” (National Research Council, 2008). Since then, the U.S. EPA has continued to address the environmental concerns regarding stormwater runoff and is currently “announcing plans to initiate national rulemaking to establish a program to reduce stormwater discharges from new development and redevelopment and make other regulatory improvements to strengthen its stormwater program” (EPA, 2010).

Given these efforts to better control the effects of land development on stormwater runoff volume and quality, LID technologies will undoubtedly become more

common. As engineers and developers continue to experiment with these strategies in order to meet the enforced regulations, the performance and cost-efficiency of LID practices will improve. This process presents many opportunities for Stantec Consulting Ltd. since the future of LID practices depends on the ability of engineers and developers to demonstrate their effectiveness while finding ways to reduce costs and maximize benefits. The current costs and benefits of two types of stormwater runoff infiltration systems are bulleted below.

### Bioretention Basins/Rain Gardens

#### Cost:

- US \$3.00 - \$15.00 per square foot (EPA, 2000)
- US \$10.00 - \$40.00 per square foot (LID, 2007)
  - Specific to commercial, industrial, and institutional projects
- US \$5,000.00 - \$10,000.00 per acre drained (PGC, 2007)

#### Benefits:

- Reduced runoff volume
- Improved runoff quality
- Increased groundwater recharge

### Vegetated Swales

#### Cost:

- US \$8.50 - \$50.00 per linear foot (SEWRPC, 1991) (CRWA, 2008)

#### Benefits:

- Same as above



Stormwater runoff infiltration systems aim to mitigate some of the detrimental consequences of land development, specifically those linked to impervious surface area. According to the U.S. EPA, many studies have documented that the quality of streams, lakes, and wetlands reduces sharply when impervious cover in an upstream watershed is greater than 10% (EPA, 2000). Increases in impervious surface area typically lead to increased run-off volume, increased run-off contamination, and decreased ground water recharge. These can then create additional consequences such as erosion, and downstream flooding. The chain of negative impacts can continue as these affect the quality and stability of eco-systems, harming a variety of native vegetation and species. Stormwater run-off infiltration systems are incorporated onto sites in an attempt to reduce and ideally prevent this chain from occurring.

According to Maryland's Prince George's County (PGC) low-impact development manual:

"Under natural and undeveloped conditions, surface runoff can range from 10 to 30 percent of the total annual precipitation. Depending on the level of development and the site planning methods used, the alteration of physical conditions can result in a significant increase of surface runoff to over 50 percent of the overall precipitation" (PGC, 1999).

Therefore, the main goal of stormwater infiltration systems is to reduce imperviousness and restore undeveloped conditions. By creating vegetated areas which replicate pre-development conditions the natural hydrologic cycle can be better maintained thus inhibiting a long list of potential, harmful consequences at the source.

Infiltration systems are designed to capture, store, treat, and transport storm water run-off in a similar manner as the native landscape of an undeveloped lot. By capturing and treating storm-water run-off close to the source, these systems protect both sewage systems and potential water supply sources. Reducing the amount of run-off alleviates the volume handled by a sewerage system. Treating the run-off protects groundwater and surface water supply sources from pollutants commonly found in run-off. The following sections will address two of the most common types of infiltration systems, bioretention areas/basins, also referred to as rain gardens, and vegetated

swales. Although both rain gardens and vegetated swales employ the same concepts their overall design, cost and applications vary.

### ***Bioretention Basins/Rain Gardens***

Bioretention basins and rain gardens refer to the same type of run-off infiltration systems. The term “bioretention” has a more technical/scientific connotation while rain gardens usually refer to small bioretention areas in residential settings that typically use aesthetically pleasing plants. Both terms are used interchangeably throughout this section.

Bioretention areas were first implemented as a stormwater management practice in Prince George’s County, Maryland. According to their bioretention design manual, the name bioretention comes from the ability of the biomass (plants, mulches, soils, etc.) to retain the nutrients and other contaminants commonly found in stormwater run-off (i.e. phosphorus and nitrogen) (PGC, 2007). However, as previously mentioned, volume control and groundwater recharges are also major benefits. These are all accomplished by allowing fifteen different natural processes to occur: interception, infiltration, settling, evaporation, filtration, absorption, transpiration, assimilation, adsorption, nitrification, denitrification, volatilization, thermal attenuation, degradation, and decomposition (PGC, 2007).

As described by Prince George’s County bioretention manual, the following natural processes allow bioretention areas to mimic predevelopment ground conditions. Interception refers to the ability of the plants, soils, and mulches to collect and capture rainfall/run-off. This process is crucial because it concentrates the captured water in the basin’s ponding area. (Descriptions of the distinct components of a bioretention area are provided in a later section). Settling allows certain solid contaminants in the captured run-off to float to the top of the ponding area. This provides some initial treatment of the water before other processes carry it any closer to sources of groundwater. Once in the ponding area, the run-off then goes through infiltration which is the process of water

moving downward from the ponding area, through the planting soil and mulches and into the surrounding and underlying existing soils. As infiltration and settling occur, evaporation at the surface of the ponding area caused by energy from the sun further reduces the volume of water in the shallow ponding area. As an effect of infiltration, particles are filtered through mulches, sands, and soils that are part of the rain garden's design. Filtration accounts for the majority of the removal of particulate matter within run-off. Before water infiltrates enough to be absorbed by plant roots, adsorption takes place in the mulch layer. Here, dissolved metals and nutrients are bound to humus which is created through the breakdown of plants and mulch. Once the plants take up all the water they need, any remaining water is still susceptible to adsorption as the water continues to infiltrate into the deeper soil layers. During filtration water takes the place of voids and air spaces within the soil, while plant roots and fungi absorb the water. After absorption, over 90% of the water initially absorbed by the plants is released into the air as vapor through transpiration. Assimilation occurs during absorption but refers to plants taking in nutrients instead of water. Further removal of contaminants is accomplished by volatilization, degradation, and decomposition. Volatilization is the process of breaking down a substance into a more unstable form. This occurs in bioretention areas through denitrification. Denitrification is the process in which microorganisms turn nitrate into other forms such as nitrogen gas and nitrous oxide. These then return into the atmosphere instead of lingering in the run-off or soils. Degradation and decomposition account for the breakdown of chemical and organic compounds respectively. Throughout the cycle of all of these processes, thermal attenuation occurs. This refers to the ability of bioretention areas to lower the temperature of the captured runoff after its infiltration. According to a study discussed in the P.G.C. bioretention manual, a bioretention basin reduced the temperature of run-off by about 11 degrees, 22 degrees Celsius from 33 degrees Celsius (PGC, 2007).

Bioretention areas are designed to take full advantage of the processes previously mentioned. A layered but holistic and systematic design makes bioretention areas rather simple techniques which promote and encourage very complex natural processes. According to the U.S. EPA's literature review on low-impact development techniques, typical bioretention areas consist of six different layers: a grass buffer strip,

sand bed, ponding area, organic layer, planting soil, and vegetation (EPA, 2000). Depending on the specifics of the site and project, additional components such as an under-drain and/or overflow system can be incorporated into the bioretention area's design.

The purpose of a buffer strip is to regulate the flow of the run-off by reducing its velocity while acting as the first filtering system for larger particles which may clog the system. Buffer strips have gentle slopes that direct runoff toward a bioretention basin. According to the Dane County Erosion Control and Storm Water Management Manual, "[to] maintain flow towards the basin, slopes should not be less than 0.5% for paved areas and 1% for vegetated areas. In any case, the slopes toward the basin should not be greater than 20%" (Dane County, 2007).

A pea-gravel diaphragm (infiltration trench), a layer of small round stones, is optional but recommended in most cases and is typically used as a pretreatment process. A pea-gravel diaphragm distributes run-off flow evenly throughout the basin and filters particulate matter as well. According to the Metropolitan Area Planning Council (MAPC), a regional agency in Boston, MA the pretreatment process protects the basin from clogging, thereby potentially reducing maintenance costs (MAPC).

In a bioretention system pretreated run-off flows into a shallow ponding area. This ponding lies directly above a layer of organic mulch and a designed mix of sand and soil. The ponding area provides for run-off storage, time for particulate settling, time for evaporation of excess run-off, and exposes the run-off to ultraviolet radiation from the sun which aids in the treatment process (Hunt, 2001).

The organic mulch layer helps filter pollutants, prevents soil erosion, and provides a medium for biological growth through the decomposition of organic material. One of the greatest benefits of this layer is that by encouraging the growth of soil microorganisms, bioretention areas have the ability to degrade petroleum-based pollutants which originate from vehicles leaking oils onto impervious surfaces. Under the organic mulch layer lays a layer of mixed sand and soil. This sand and soil is typically designed to maintain the region's native plants and absorb contaminants within a site such as hydrocarbons and heavy metals. Unwanted nutrients, such as nitrogen and phosphorous are also adsorbed to the soil. The final layer of plants/vegetation

removes water from the soil through evapotranspiration and pollutants through nutrient cycling (Lake Superior Streams, 2005). This layer also provides the opportunity of making a bioretention area an aesthetically pleasing green space.

Depending on the permeability of the soil and/or the amount of run-off, additional layers may be required. For example, an under-drain system or an overflow system can be incorporated to distribute the excess run-off to nearby receiving waters or a sewerage system. Including either of these two systems creates the distinction between the two types of rain gardens: under-drained and self-contained. Self-contained systems are able to capture, treat, and infiltrate water into the soil without the need of additional draining. The under-drained system is used when infiltration is not suitable due to several possibilities (Lake Superior Streams, 2005). Infiltration is not suitable or desirable in cases where the groundwater can become contaminated by contaminants in run-off. According to the Low Impact Development Center these include cases where there is less than 4 feet between the seasonal mean high water table and the bottom of the rain garden as well as areas with contaminated soils (LID, 2007). Low permeability of existing soils or excessive run-off patterns could also cause the bioretention system to flood. In such cases under-drained systems are also recommended.

Additional differences between under-drained and self-contained rain gardens include drainage time and plant selection. Self-contained areas are designed to be drained within four hours after a 1" rain event. Under-drained rain gardens typically are designed to drain within 2 hours of the design storm event. When an under-drain is used, the run-off is quickly diverted which means that the plants used must be able to withstand both the extremes of flooding and drought (LID, 2007). Xeric plants, or those which require very little water, are used on the upper edges and sides of the rain garden while plants which can adapt to floodplain conditions are used in the middle, lower parts (EPA, 2000). Self-contained rain gardens retain water for a longer period of time but the saturation capacity of the soils throughout the area is comparable to the soil conditions within an under-drained system. Both have low saturation capacity soils along the top and increasing saturation capacity towards the lower parts. However, plants used toward the bottom of self-contained bioretention areas must be able to withstand more inundation.

According to the Low Impact Development Center, in both the under-drained and self-contained rain gardens, healthy and small plants have proven to adapt more successfully than older, larger plants (LID, 2007). Additionally, their rain garden design template explains that “plants with deep fibrous roots tend to have a competitive advantage in a rain garden and provide the most cleaning and filtration benefits to the environment” (LID, 2007). Therefore, the seeding or early planting of drought resistant plants known to develop deep roots would be ideal.

## Potential Benefits

Bioretention areas increase groundwater recharge, enhance the landscape, provide wind breaks, absorb noise, provide wildlife habitat, and reduce the urban heat island effect (MAPC). In addition, bioretention areas provide the following benefits:

- Conserves or establishes a unique and historical sense of natural identity (i.e. native plants) (PGC, 2007). County, Maryland
- Promotes environmental education and responsibility (PGC, 2007).
- Increases aesthetic appeal and thus real estate values by up to 20% (PGC, 2007).
- Lessen storm-water runoff flow
  - A study done in 2005 in Haddam, CT showed that 98.8% of inflow from roof run-off and precipitation was released through subsurface flow (Dietz, 2005).
- Improve storm-water quality
  - According to Prince George’s County best practices manual, bioretention areas have shown to efficiently reduce the following pollutants/contaminants (EPA, 2000).
    - Total suspended solids – 97%
    - Total Phosphorus – 35%-65%

- Total Nitrogen – 33%-66%
  - Copper – 36%-93%
  - Lead – 24%-99%
  - Zinc – 31%-99%
  - Oil and grease – 99%
  - Bacteria – 70%
- The PGC bioretention manual provides the following table summarizing the pollutant removal efficiency of a bioretention area studied by the University of Maryland’s Engineering Department (PGC, 2007).

**Table 17: Bioretention Pollutant Removal Efficiency (PGC, 2007)**

Cumulative Percent Removal by Depth*								
Laboratory/Field Summary								
Depth	Cu	Pb	Zn	P	TKN	NH4	NO3	TN
1'	90	93	87	0	37	54	-97	-29
2'	93	99	98	73	60	86	-194	0
3'	93	99	99	81	68	79	23	43

\*Modified from experimentation performed by Dr. Allen Davis, University of Maryland

## Potential Risks and Considerations

The following is summarized from the Minnesota stormwater management manual and is specific to bioretention areas (Lake Superior, 2005):

- There is very limited data regarding their long-term performance, operation and management.
- Suitability is limited to small drainage areas.
- Their design can become more complex when used in regions with Karst topography (limestone and caves) or in contaminant hot spots, in order to prevent groundwater contamination.

- Bioretention areas are susceptible to clogging.
- Bioretention areas require large areas of land; this may conflict with development (i.e. reduce the number of parking spaces)
- Bioretention areas have relatively higher initial costs (construction) compared to conventional stormwater systems.
- Use in cold climates result in costly design modifications

Since most rain gardens incorporate mulches and plants, they are perceived as part of a site's landscape design and thus are expected to look clean, neat, and well maintained. If these expectations are not met, rain gardens can be rejected from a project or limited to areas out of the general public's site. Therefore the poor aesthetic appeal which rain gardens can develop over time is another major deterrent of many projects. This poor image can be attributed to two possibilities: the improper design and/or improper maintenance of the rain garden. When a rain garden is inadequately designed, the project can look unkempt and/or dead and this can actually discourage proper maintenance. These projects then serve as evidence of failed designs which further discourage the use of bioretention areas. Therefore the proper design of a rain garden, specifically in terms of plant selection is crucial to this technology's overall appeal and reputation. However, as written in "A Paradox of Nature", an article by Kevin Beuttell (Stantec employee) "one of the challenges in the rain garden design is creating a hydrology and soil moisture that is preferred by a broad enough range of plants to achieve performance and aesthetic objectives" (Beuttell, 2010)

Therefore, several Stantec employees have begun to apply a new approach to the design of bioretention gardens. Instead of conforming to the conventional model which mimics the design of a wetland, several successful projects have been designed as "dry environments that experience only brief wet periods" (Beuttell, 2008). This concept is founded on the differences between the hydrologic cycle of wetlands and bioretention areas which are shown in the following diagrams.



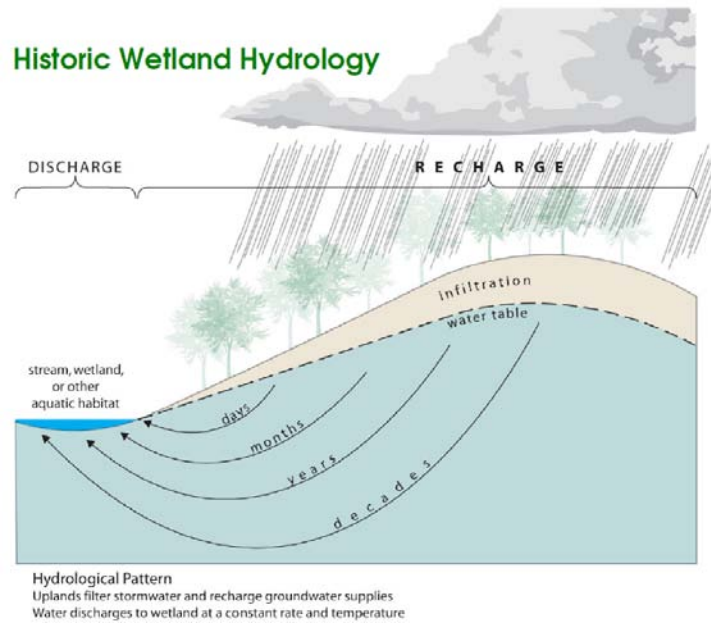

**Figure 16: Wetland Hydrology (Beuttell, 2010)**

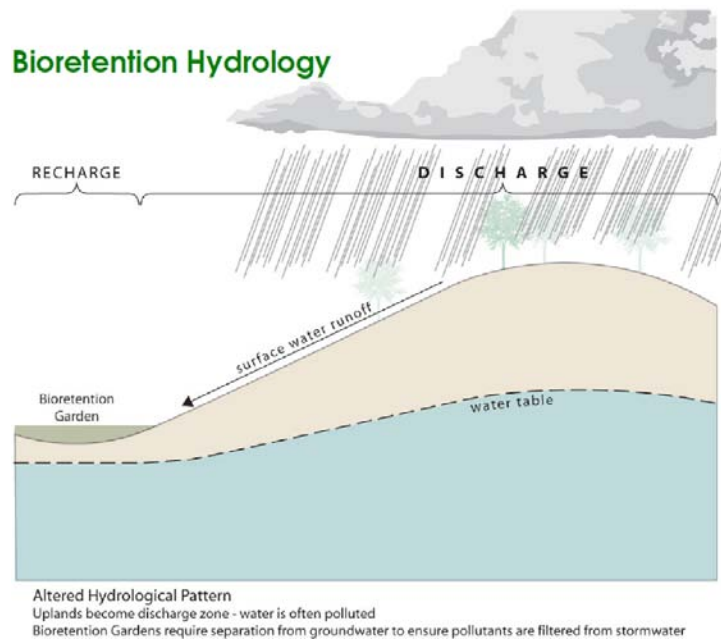

**Figure 17: Bioretention Hydrology (Beuttell, 2010)**

The hydrology of a wetland demonstrates how receiving waters are replenished through infiltrated rainwater. This can range from several days to years and, given

adequate rainfall, provides steady and gradual groundwater recharge. On the other hand, the bioretention hydrology diagram shows how a rain garden is only fed by surface water runoff which follows the irregular patterns of rainfall. These differences have led to the concept of the dry approach which alters the design of the rain garden in several ways including the position of the underdrain, the thickness of the soil layer, and the selection of plants.

Conventional systems, shown in Figure 18, are characterized by the low position of the underdrain, a deep soil layer and both xeric (drought resistant) and water-loving plants. However, the dry bioretention design, shown in Figure 19 and Figure 20, show that the high placement of a perforated pipe within a stone trench and a shallow top soil layer allow for better infiltration. Also, diverse drought tolerant grasses and wildflowers are used instead of xeric and water-loving plants. Although it is very difficult to predict the range of conditions which the plants will be exposed to over a long period of time, this dry design approach rightfully assumes that none of the plants (even those in the lower parts of the rain garden) will be exposed to much inundation. While ponding may occur, bioretention areas are designed to infiltrate relatively quickly. By including diverse plants one can experiment with their longevity and performance and alter the overall design later if needed. Approaching bioretention designs in this way can establish a better relationship between vegetation, soil, and performance, ultimately resulting in aesthetically pleasant and functional systems. It should be noted that the conventional designs are more applicable in cases where runoff treatment instead of infiltration is a priority.

## Conventional Bioretention Design

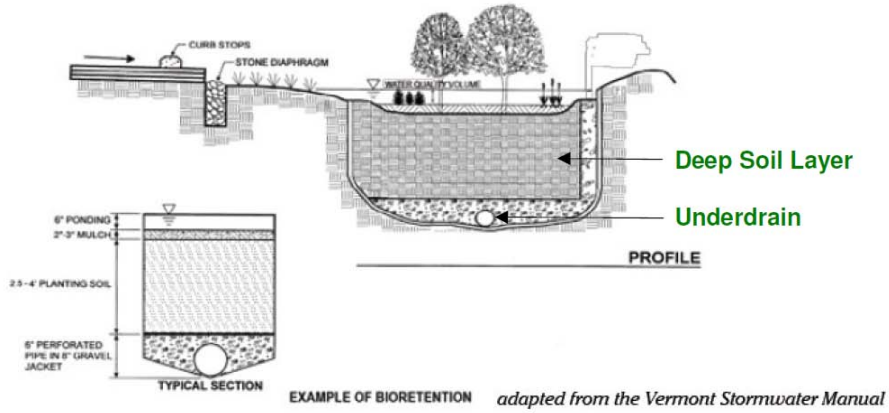

Figure 18: Conventional Bioretention Systems (Beuttell, 2010)

## “Dry” Bioretention Design

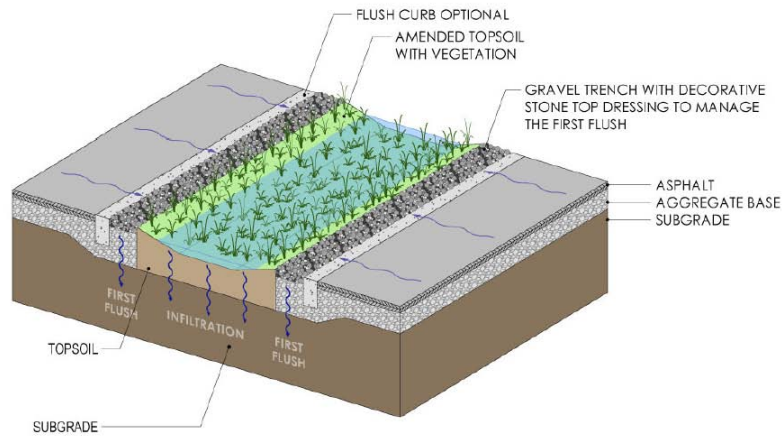
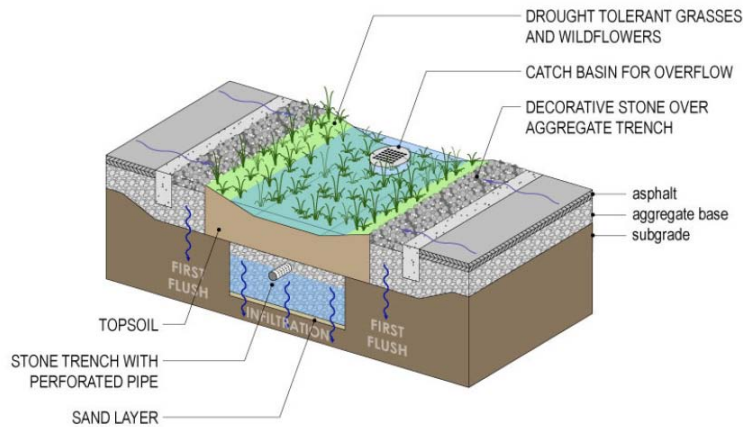

Figure 19: Dry Bioretention Design (Beuttell, 2010)



### Subsurface Gravel Retention

- Reduce ponding depth and time at planting surface
- Appropriate for tight spaces and/or lower infiltration rates

**Figure 20: Dry Bioretention Design 2 (Beuttell, 2010)**

## Estimated Costs

Although bioretention areas tend to have higher initial costs than conventional stormwater systems, the U.S. EPA's literature review on low impact strategies development concluded that bioretention areas are less cost intensive than traditional structural stormwater systems (LID, 2000). This is true because although the installation and maintenance of bioretention areas may be initially more expensive than conventional systems, their use can produce savings by reducing the need for conventional storm water management systems. According to PGC's bioretention manual, several case studies found that integrating bioretention across a site can reduce overall development costs by 15% to 50% when compared to development incorporating conventional stormwater practices (PGC, 2007). For example, in Prince George's County, Maryland bioretention practices saved \$24,000 (50% of the overall drainage cost) at a Medical Office building (EPA, 2000). These savings were obtained by reducing the amount of drain pipe needed from 800 to 230 feet. Since the greatest cost savings are obtained when bioretention areas reduce the need of other systems,

the maximum cost-efficiency can be acquired by incorporating bioretention areas into new development. In this way the bioretention areas can be designed to take advantage of the site's existing traits (natural slopes) and could potentially eliminate the need of any other stormwater systems. However, employing bioretention areas in existing lots have many benefits that may be difficult to quantify but should be considered. The following is a list of estimated costs for bioretention projects:

- According to the Low Impact Development's Urban Design Tools' site, residential rain garden cost between U.S. \$3.00 - \$4.00 per square foot and commercial, industrial, and institutional rain gardens range from U.S. \$10.00 - \$40.00 per square foot (LID, 2007).
- According to Prince George's County, Maryland typical bioretention areas cost between \$5,000 and \$10,000 per acre drained.
- In 2000 the US EPA concluded that average bioretention basins costs range from US \$3.00 and US \$15.00 per square foot of bioretention area (EPA, 2000).
- A 900-square-foot bioretention basin designed to treat runoff from ½ impervious acre in Fairfax County cost \$US 1,125.00 per year.

The following information is from Prince George's County stormwater management manual. It outlines several components of designing and constructing a bioretention basin and applies an average cost for each (PGC, 2007)

**Table 18: Bioretention Costs (PGC, 2007)**

<b>Task</b>	<b>1. Res. Rain Garden</b>	<b>2. Res. lot in a Sub Division</b>	<b>3. Res. Single Lot</b>	<b>4. Commercial New Const.</b>	<b>5. Commercial Retrofit</b>
<b>Total Cost</b>	\$ 1075	\$ 3790	\$ 7775	\$ 10357	\$ 12355
<b>Planning Phase</b>	\$ 25	\$ 95	\$ 200	\$ 845	\$ 350
<b>Design Phase</b>	\$ 100	\$ 340	\$ 875	\$ 3600	\$ 2410
<b>Construction</b>	\$ 950	\$ 3225	\$ 5750	\$ 5237	\$ 7943

<b>Close Out</b>	NA	\$ 130	\$ 950	\$ 675	\$ 1652
------------------	----	--------	--------	--------	---------

The above costs reflect the assumptions made by its corresponding scenario:

1. Average costs per facility installed, assuming a 100 lot subdivision and no underdrain systems.
2. Average costs assuming a shallow rain garden without an underdrain system. Most of the labor is done by the homeowner.
3. Costs are increased substantially due to the small scale of the project, and closeout is higher due to as-built requirements.
4. The facility construction costs are lower than that for a single residential lot because of the increase in related site work. The storm drainage discharge system is not included as part of the bioretention costs since it is treated as a general site expense.
5. Total retrofit costs are higher than those for new construction due to economies of scale. Design costs are lower because the drainage conveyance system is already in place (LID, 2007).

## **Recommended Site Characteristics**

Bioretention areas are very flexible in terms of design. Although the types of layers are usually consistent from project to project, the performance of each layer can be altered in order to best suit a specific site. Bioretention basins have been used in residential, commercial, and industrial lots and are very common in run-off source areas of such as parking lots. Figure 21 shows an example of a bioretention basin in a parking lot. They are suitable for suburban as well as urban environments and can be easily incorporated into new or existing developments (LID, 2007). Factors such as annual

rainfall, size of the drainage area, existing soil conditions, existing slopes, and ground water levels will impact the design of rain gardens.



**Figure 21: Bioretention Example 1 (Landcare Research, 2010)**

Bioretention practices usually perform the best in urbanized spaces and on small lots (LSS, 2005). According to Lake Superior, Minnesota's stormwater management manual, the following should be considered when determining a site's suitability for bioretention areas (LSS, 2005):

- Bioretention areas work well on sites where little pervious surface exist such as parking lots and large buildings.
- Bioretention areas are suitable on sites where existing developments are required to retrofit stormwater management practices
- In areas with highly contaminated runoff (such as gas stations), the bottom of a bioretention basin should be lined with impermeable liner to prevent the spread of contamination.

Idaho's Department of Environmental Quality lists the following design considerations (IDEQ, 2005):

- Size of the drainage area should ideally be less than 1 acre with slopes of less than 20%.
- Size of bioretention basin should be between 5%-7% of drainage area.
- Planting soils should be loamy with a clay content of 10 to 25%.
- The soil should contain 3 to 5% organic material and have a pH of 5.5 to 6.5.
- Bioretention facilities should not be used in areas with shallow aquifers.

Further site considerations include the exact positioning of the bioretention basin within a lot. According to the Dane County Erosion Control and Storm Water Management Manual,

“Appropriate placement of bioretention basins is important because of the need for proper maintenance. For example, basins located in open, visible areas are more likely to be properly maintained and, in turn, provide aesthetic value. Also, bioretention basins should not be used near foundations, basements, roads, or on sites with high water tables or steep slopes.” (DCEC, 2007).

Prince George’s County Bioretention Manual encourages rain gardens for the following types of projects (PGC, 2007):

- New Residential Developments.
- New Commercial/Industrial Developments.
- Roadway Projects.
- Institutional Developments.
- Redevelopment Communities.
- Revitalization and Smart Growth Projects.
- Urban Retrofit Stormwater Management Projects.
- Streetscaping Projects.
- Private Residential Landscaping.



- Parks and Trailways.

While under-drained and self-contained are the two major types of rain gardens, each can be broken down further depending on specific project needs and existing site characteristics. The Prince George's County, Maryland bioretention manual offers four examples. As opposed to the conventional self-contained bioretention basin, one which does not include a geotextile fabric can be beneficial for cases where groundwater recharge is especially needed. This type of basin is called an infiltration/recharge facility. These are suitable for residential and business areas that expect to generate nutrient runoff levels that can be infiltrated and captured by the rain garden. According to the PGC bioretention manual, the main considerations for this type of rain garden are the following.

- Soils need a high infiltration rate (1 inch/hour or greater) to accommodate the stormwater run-off inflow levels.
- Basin must be deep enough (at least 2.5 feet) to allow adequate filtration processes to occur.
- Fresh mulch can be used to enhance the denitrification processes.
- Soils consisting of 50-60% sand, 20-30% top soil, and 20-30% leaf compost help achieve a high infiltration capacity.
- These basins are more suitable where aesthetics are not a main concern since the captured run-off may remain in the pond for extended amounts of time.

Furthermore, three different types of under-drained bioretention basins are described in PGC's bioretention manual: filtration/partial recharge, infiltration/filtration/recharge, and filtration only. In areas where high filtration and partial recharge is desired, the filtration/partial recharge rain garden is most suitable. These are usually very aesthetically pleasing and filter the run-off rather quickly. They are great for entry locations within a community and for land uses that are expected to generate nutrient and metals loadings. Infiltration/Filtration/Recharge basins are recommended for areas that generate high nutrient loadings. This type of rain garden

would be best for areas where nitrate loadings are a major concern. Filtration only is recommended for areas that are known as “hot-spots”, such as gas stations, transfer sites, and transportation depots. In this system, an impervious liner is designed to reduce or eliminate the possibility of groundwater contamination (PGC, 2007).

## ***Vegetated Swales***

While vegetated swales operate much like other bioinfiltration systems they are typically designed for runoff transport as well as infiltration (IDEQ, 2005). Vegetated swales are open shallow channels which capture, treat, convey, and infiltrate stormwater run-off. Both swales and rain gardens employ the same methods for managing stormwater. Therefore they share the same benefits and limitations and are applicable to similar site conditions. Both perform similarly in regards to pollutant removal and volume reduction of stormwater run-off, but the performance of each system are heavily dependent on the characteristics of the projects they are used on. Also, vegetated swales have thicker vegetation covering the side slopes and bottom which aid in the collection and conveyance of runoff to downstream discharge points (ACCWP, 2006).



**Figure 22: Vegetated Swale Example (Alameda, 2006)**

## Estimated Costs

- According to the Charles River Watershed Association (CRWA) a Geosyntec Consultant in 2007 estimated that vegetated swale installation costs were about US \$10.00 per linear foot (CRWA, 2008).
- In 2005 the U.S. EPA reported that maintenance costs for a 900 square foot vegetated swale were roughly US \$200.00 per year (CRWA, 2008).
- In 1991 the Southeastern Wisconsin Regional Planning Commission reported that actual costs of a vegetated swale may range from \$8.50 to \$50.00 per linear foot depending on swale depth and bottom width (SEWRPC, 1991).
- According to the University of New Hampshire the cost to install a vegetated swale to treat runoff from one acre of impervious surface was \$12,000. This did not including maintenance costs (UNH, Vegetated Swales).

## Recommended Site Characteristics

Much like rain gardens, vegetated swales are suitable for a variety of sites and projects. The characteristics listed in the bioretention area section are also applicable to vegetated swales. The most significant difference is that since vegetated swales are used to transport run-off further horizontal distances they are usually applied along residential streets and highways. Therefore vegetated swales typically have much greater coverage than typical rain gardens (EPA, 2000). Figure 8 shows an example of a vegetated swale along the side of a long street. Because of this, vegetated swales require more available land and may be harder to incorporate in areas where land isn't readily available such as heavily urbanized cities. A vegetated swale can be used in lieu of curbs and gutters and are recommended when the project site has a natural grade (UNH).

## **Potential LEED Credits**

### Sustainable Sites:

- Credit 6.1 – “Stormwater Design – Quantity Control” (1 point)
- Credit 6.2 – “Stormwater Design – Quality Control” (1 point)
- Credit 7.1 – “Heat Island Effect – Non-Roof” (1 point)

### Water Efficiency:

- Credit 1 – “Water Efficient Landscaping” (2-4 points)

## **Relevant Stantec Projects**

### **1. WestJet Campus – P&LA**

Location: [Calgary, Alberta, CA](#)

Description: This project included several sustainable techniques including rainwater collection and bioretention areas.

Link:

[http://marketingexcellence/projectprofile\\_preview.aspx?id=10&project=12922](http://marketingexcellence/projectprofile_preview.aspx?id=10&project=12922)

### **2. Heritage Flight Aviation Campus Expansion**

Location: [Burlington, Vermont, USA](#)

Description: Sustainable design elements of the project included a porous concrete pavement parking lot, and bioretention area.

Link:

[http://marketingexcellence/projectprofile\\_preview.aspx?id=10&project=17658](http://marketingexcellence/projectprofile_preview.aspx?id=10&project=17658)

### 3. Ferrisburgh Park and Ride Facility

Location: [Vergennes-Ferrisburgh, Vermont, USA](#)

Description: Stantec provided scoping, conceptual and final design, environmental permitting, and contract plans for this Park-and-Ride multi-modal facility. The project features an innovative bioretention area to treat stormwater runoff.

Link:

[http://marketingexcellence/projectprofile\\_preview.aspx?id=10&project=18590](http://marketingexcellence/projectprofile_preview.aspx?id=10&project=18590)

### 4. Brown Property

Location: [Huntersville, North Carolina, USA](#)

Description: Stantec's engineers successfully designed the Brown Property to meet and or exceed the low impact design stormwater management requirements for Mecklenburg County and the Town of Huntersville, North Carolina.

Link:

[http://marketingexcellence/projectprofile\\_preview.aspx?id=10&project=15149](http://marketingexcellence/projectprofile_preview.aspx?id=10&project=15149)

## Sources

1. Alameda Countywide Clean Water Program, "Stormwater Technical Guidance: Vegetated Swales", 2006, Accessed Feb. 2, 2010.

[http://www.cleanwaterprogram.org/uploads/ACCWP\\_Tech\\_guidance-bwgray.pdf](http://www.cleanwaterprogram.org/uploads/ACCWP_Tech_guidance-bwgray.pdf)

*A stormwater technical guidance handbook written by a consortium of local agencies for developers, builders, and project applicants within Alameda County, CA.*

2. Beuttell, Kevin. "A Paradox of Nature: Designing Rain Gardens to be Dry". 2008, Accessed Feb 18, 2010.

*An article written by a Stantec employee on the proper design of rain gardens in order to maximize aesthetic appeal and performance.*

3. Beuttell, Kevin. "Bioretention Gardens: A Dry Design Approach". 2010. Accessed Feb 18, 2010.

*A presentation by a Stantec employee on why designing bioretention areas to be dry is more effective than conventional methods.*

4. Clark, Mark; Acomb, Glenn, "Bioretention Basins/Rain Gardens", 2008, Accessed Jan. 25, 2010.

[http://buildgreen.ufl.edu/Fact\\_sheet\\_Bioretention\\_Basins\\_Rain\\_Gardens.pdf](http://buildgreen.ufl.edu/Fact_sheet_Bioretention_Basins_Rain_Gardens.pdf)

*The University of Florida's Program for Resource Efficient Communities' fact sheet on bioretention basins/rain gardens as part of Florida's field guide to low-impact development.*

5. Charles River Watershed Association, "Vegetated Swales", 2008, Accessed Feb. 1, 2010. [http://www.crwa.org/projects/bmpfactsheets/crwa\\_vegetated\\_swale.pdf](http://www.crwa.org/projects/bmpfactsheets/crwa_vegetated_swale.pdf)

*An information sheet on vegetated swales, written as part of the Charles River, MA Watershed Association's low-impact development best management practices.*

6. Dietz, Michael; Clausen, John, "A Field Evaluation of Rain Garden Flow and Pollutant Treatment", 2005, Accessed Feb. 2, 2010, Available at <http://www.springerlink.com/content/700500546046v462/>

*Published research by the University of CT. Department of Natural Resources Management and Engineering on the field performance of rain gardens constructed in Haddam, CT.*

7. Dane County Erosion Control and Storm Water Management Manual, "Bioretention Basin", 2007, Accessed Feb. 1, 2010. [http://danewaters.com/pdf/manual/Appendix\\_1/BioretentionBasin.pdf](http://danewaters.com/pdf/manual/Appendix_1/BioretentionBasin.pdf)

*A fact sheet on bioretention areas written as part of Dane County, WI. stormwater management manual.*

8. Hunt, W.F.; White, N.M., "Bioretention Performance, Design, Construction, and Maintenance", 2001, Accessed Jan. 25, 2010. <http://www.bae.ncsu.edu/stormwater/PublicationFiles/Bioretention2006.pdf>



*Several bioretention cell case studies in North Carolina are presented and analyzed for field performance.*

9. EPA, “Low Impact Development: A Literature Review”, 2000, Accessed Jan. 25, 2010. <http://www.epa.gov/owow/nps/lid/lid.pdf>

*“A literature review was conducted to determine the availability and reliability of data to assess the effectiveness of low impact development (LID) practices for controlling stormwater runoff volume and reducing pollutant loadings to receiving waters”.*

10. EPA, NPDES, “Proposed National Rulemaking to Strengthen the Stormwater Program”, 2010. Accessed Feb. 17, 2010.

<http://cfpub.epa.gov/npdes/stormwater/rulemaking.cfm>

11. EPA, “Stormwater Phase II Final Rule: An Overview”. 2000, Accessed Feb. 23, 2010. <http://www.epa.gov/npdes/pubs/fact1-0.pdf>

12. EPA, “Stormwater Technology Fact Sheet: Vegetated Swales”, 1999, Accessed Jan. 25, 2010. <http://www.epa.gov/owm/mtb/vegswale.pdf>

*The EPA’s fact sheet on vegetated swales written as part of their stormwater technology fact sheet.*

13. Idaho Department of Environmental Quality “Bioretention Basin”, 2005, Accessed Feb. 1, 2010.

[http://www.deq.state.id.us/WATER/data\\_reports/storm\\_water/catalog/sec\\_4/bmps/9.pdf](http://www.deq.state.id.us/WATER/data_reports/storm_water/catalog/sec_4/bmps/9.pdf)

*A bioretention fact sheet written as part of the Idaho Department of Environmental Quality's Stormwater Best Management Practices Catalog.*

14. Lake Superior Streams, "Bioretention Basins", 2005, Accessed Feb. 1, 2010.  
<http://www.duluthstreams.org/stormwater/toolkit/bioretention.html>

*An entire site devoted to encouraging proper stormwater management techniques including information on bioretention areas and their specific designs within the Lake Superior area of MN and WI.*

15. Landcare Research, Manaaki Whenua New Zealand. "LIUDD Case Studies". 2010, Accessed Feb. 23, 2010.  
[http://www.landcareresearch.co.nz/research/built/liudd/casestudies/case\\_manukau.asp](http://www.landcareresearch.co.nz/research/built/liudd/casestudies/case_manukau.asp)

16. Low Impact Development Center Inc, "Bioretention", 2007, Accessed Feb. 1, 2010. [http://www.lid-stormwater.net/bio\\_costs.htm](http://www.lid-stormwater.net/bio_costs.htm)

*The site offers general information on several low-impact development technologies including bioretention areas.*

17. Low Impact Development Center Inc, "Rain Garden Design Templates", 2007, Accessed Feb. 1, 2010.  
[http://www.lowimpactdevelopment.org/raingarden\\_design/whatisaraingarden.htm](http://www.lowimpactdevelopment.org/raingarden_design/whatisaraingarden.htm)

*The Low Impact Development Center's site on bioretention areas offers good design and performance information as well as templates.*

18. Metropolitan Area Planning Council, "Bioretention Areas", Accessed Feb. 2, 2010. <http://www.mapc.org/smart-growth/low-impact-development-toolkit/fact-sheet-bioretention-areas>

*A fact sheet on bioretention areas written as part of the Metropolitan Area Planning Council's smart growth section.*

19. National Research Council, "Urban Stormwater Management in the United States". 2008. Accessed Feb. 23, 2010. [http://www.epa.gov/npdes/pubs/nrc\\_stormwaterreport.pdf](http://www.epa.gov/npdes/pubs/nrc_stormwaterreport.pdf)

20. Prince George's County, Maryland: Environmental Services Division, "Bioretention Manual", Dec. 2007, Accessed Feb. 1, 2010. [http://www.princegeorgescountymd.gov/Government/AgencyIndex/DER/ESG/Bioretention/pdf/Bioretention%20Manual\\_2009%20Version.pdf](http://www.princegeorgescountymd.gov/Government/AgencyIndex/DER/ESG/Bioretention/pdf/Bioretention%20Manual_2009%20Version.pdf)

*A complete manual on the planning, design, construction, and performance of bioretention basins written for Prince George's County, Maryland; the birthplace of low-impact development strategies.*

21. Prince George's County, Maryland Department of Environmental Resources, "Low-Impact Development Design Strategies", 1999, Accessed Feb. 2, 2010. <http://www.epa.gov/owow/nps/lid/lidnatl.pdf>

*A thorough manual covering low-impact development strategies and promoting integrated design.*

22. PR Design and Engineering Inc. "Best in Award". 2006, Accessed Feb. 24, 2010. <http://pastoreryan.com/articles/2006-best-in-the-basin-award/>

*Photo source and includes case studies of BPMs in Tahoe, CA.*

23. Stormwater Center, "Stormwater Management fact Sheet: Bioretention", 2000, Accessed Jan 25, 2010  
[http://www.stormwatercenter.net/Assorted%20Fact%20Sheets/Tool6\\_Stormwater\\_Practices/Filtering%20Practice/Bioretention.htm](http://www.stormwatercenter.net/Assorted%20Fact%20Sheets/Tool6_Stormwater_Practices/Filtering%20Practice/Bioretention.htm)

*The Stormwater Management Resource Center's fact sheet on bioretention areas.*

24. University of Florida, "Bioswales /Vegetated Swales", 2008, Accessed Jan. 25, 2010. [http://buildgreen.ufl.edu/Fact\\_sheet\\_Bioswales\\_Vegetated\\_Swales.pdf](http://buildgreen.ufl.edu/Fact_sheet_Bioswales_Vegetated_Swales.pdf)

*The University of Florida's Program for Resource Efficient Communities' fact sheet on vegetated swales as part of Florida's field guide to low-impact development.*

25. University of New Hampshire, "Vegetated Swales", Accessed Feb. 1, 2010, Available at [http://www.unh.edu/erg/cstev/fact\\_sheets/veg\\_swale\\_fact\\_sheet\\_08.pdf](http://www.unh.edu/erg/cstev/fact_sheets/veg_swale_fact_sheet_08.pdf)

*A fact sheet on vegetated swales written by the University of New Hampshire.*

## Rainwater Harvesting

Rainwater harvesting is a water conservation technique that has been used since ancient times. There is evidence that rainwater harvesting systems were used as long far back as 4,000 years ago (Krishna et al, 2005). However, as people became more urban and more centralized water supply systems became needed rainwater harvesting became used less (Leung, 2005). Recently pollution and water shortages have made urban planners reevaluate the use of rainwater harvesting, and a number of states and municipalities have passed legislation to encourage the use of rainwater harvesting techniques.

In 2008 the city of Tucson, Arizona became the first municipality to require rainwater harvesting to be used by developers. The law in Tucson requires 50% of landscaping needs to be met by rainwater harvesting on commercial properties (Meinzen, 2009). As of August 2008 the city of Vancouver had sold over 2,000 rain barrels to its citizens while subsidizing the barrels costs by 50% (Leung, 2008). In 2001 the state of Texas amended its tax code to allow smaller units of government (such as municipalities) to grant tax breaks to properties that utilized rainwater harvesting techniques. Since then both Austin and San Antonio have passed rebate systems for citizens who install rainwater harvesting systems (Meinzen, 2009). It is likely that states and municipalities that experience water shortages will continue to encourage the use of rainwater harvesting to lower potable water demand.

Stantec can use rainwater harvesting to help lower potential customers maintenance costs for buildings landscaping. By installing irrigation rainwater harvesting systems a client will not have to water the grass and/or plant life outside of their building, as the rainwater harvesting system will do it automatically. This will help the customers reduce water consumption and reduce the need for maintenance workers. By utilizing rainwater harvesting Stantec can provide cost effective sustainable options to potential clients that will make Stantec's bid more attractive.

## Rainwater Harvesting

- Cost:
  - Extremely variable based on size of the system – see estimated costs section for case studies.
  - Cost of a rainwater harvesting system can be estimated to be:
    - US \$0.30-4.00/gal for the storage tank
    - US \$0.30-12.00/ft of gutter
    - US \$200-500 per pump
    - US \$20-3,000 for filters and disinfection systems
- Benefits:
  - Reduction in potable water use
  - Can lower stormwater runoff
  - Can lower costs for the end user
- Risks:
  - Rainwater may not be of high enough quality for end use.
  - Storage tanks must be properly sized and have ability to drain excess water.

## ***Technical Description***

Rainwater harvesting is the process of capturing rainwater and using it instead of potable water. The amount of potable water that is conserved using this method varies greatly depending on various characteristics such as volume and consistency of rainfall, rainwater catchment area, rainwater storage tank size, and the building's potable water usage. These factors impact both capital and operating costs.

Typically rainwater harvesting systems consist of a catchment area, a treatment process, a storage tank, and piping to the intended use, as shown in Figure 23. For most domestic rainwater harvesting systems the catchment areas consists of the

building's roof. The treatment, size of the storage tank, and the extensiveness of the rainwater's piping system all depend on the final use of the rainwater.

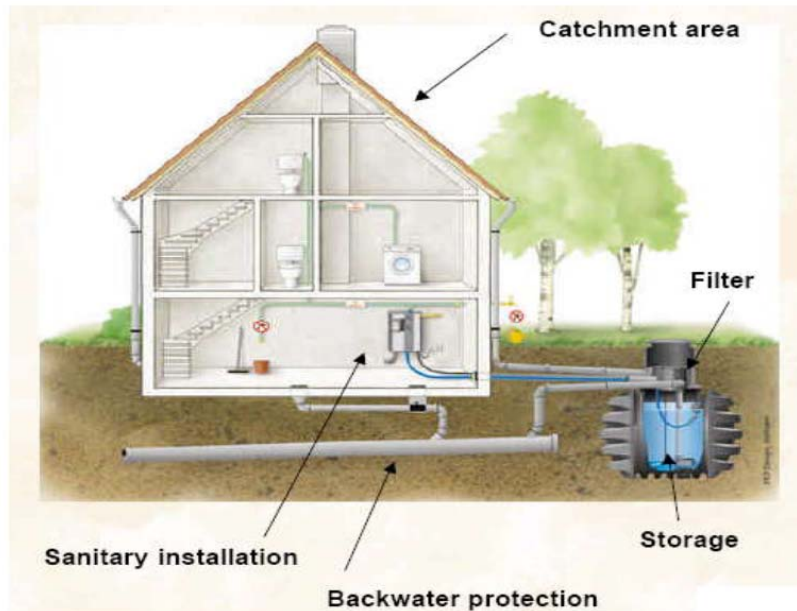

**Figure 23: Rainwater Harvesting System (Zhang, 2008)**

There are a variety of ways to ensure water quality of rainwater. A very common feature of a treatment system is a first flush device. A schematic of a first flush diagram is shown in Figure 24. The device works by filtering the rainwater to separate debris, and then storing this runoff in a chamber, allowing contaminants to settle and be released through a small hole in the bottom. The cleaner water at the top of the chamber is allowed to flow to the storage tank (Cross and Duncan, 2007). This device prevents larger debris from entering the storage tank.

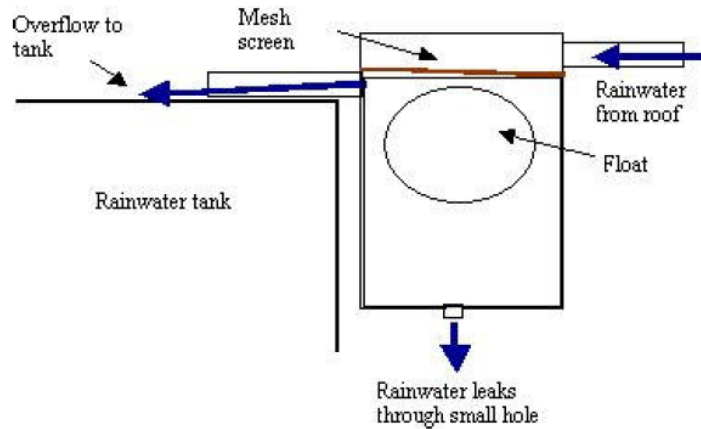

Figure 24: First Flush Device (Cross and Duncan, 2007)

After the water is filtered by a first flush device it is stored in a tank. The size of the tank greatly affects the economic feasibility of the system, as the cost of tank installation tends to be the largest component of rainwater harvesting system's cost (Chilton et al, 2000). Therefore when designing a rainwater harvesting system it is very important to size the storage tank correctly.

The quality of rainwater collected also needs to be monitored if it is to be used for drinking. This is because rainwater can be contaminated with microbes, metals, or chemicals. Also, the physical qualities (such as appearance and odor) of the water must be taken into account. Depending on the quality of rainwater at a site and the intended use, a variety of filtration and/or disinfection methods can be used to improve the quality of rainwater.

### ***Potential Benefits***

The potential benefits of using rainwater harvesting include:

- A reduction in potable water use.



- When considering a rainwater harvesting system it is useful to note that 1" of rain x 1 sq. ft. = 0.623 gallons. However, between 10% and 25% of rainwater is lost to phenomena such as surface wetting, evaporation, transpiration (Krishna et al, 2005).
  - A 2009 study in Brasilia Brazil found that car washing petrol stations could reduce their potable water requirements by as much as 57% depending on the roof catchment size, daily water demand, and size of storage tank (Ghisi et al, 2009).
  - A 2008 study of two buildings in Arlington, VA, USA investigated a 601,790 SF and a 212,947 SF commercial building and found that the building could have supplied 4.1% and 12.8% of their potable water needs using rainwater harvesting had the system been installed during construction (Hicks, 2008).
  - A 2006 study in Florianopolis Brazil found that three blocks of apartment buildings could reduce potable water consumption by 14.7%, 15.6%, and 17.7% (Ferreira and Ghisi, 2006).
  - A 2005 case study in Palhoca, Brazil that used a 5,000 L storage tank and a 3,000 L storage tank for two separate houses found that potable water usage was reduced by 35.5% and 33.6% respectively (Ghisi and Oliveira, 2006).
  - A 1999 case study in Thamesmead, UK found that 20% of a supermarket's potable water demand was met by rainwater harvesting using a 14.56 m<sup>3</sup> storage tank. However, the study noted that this system was not optimized, as it only used half of the supermarket's roof as a catchment area (Chilton et al, 2000).
- Potentially lower water bills (see estimated costs below for more information)
  - Lower storm water discharges.
    - A 2000 case study of a rainwater collection system in Berlin with a catchment area of 11,770 m<sup>2</sup> found that the system could collect and treat 10 m<sup>3</sup> of water a day. Of the water collected, 63% is from roofs, 35% from courtyards and

- sidewalks, and 12% from traffic surfaces. The rainwater is diverted to a treatment system and treated using a first flush filter, a biological “planted” substrate filter, and UV disinfection. This water was then used for irrigation and toilet flushing for 80 apartments and 6 small trade units (Nolde, 2006).
- Ability to irrigate plants that might otherwise not receive enough water.
    - A 2002 feasibility study of using rainwater harvesting to irrigate crops in Gansu province China found that rainwater captured from highway surfaces, roof tops and courtyards and manmade catchment structures could be used to increase the yield of spring wheat, corn, and potato crops by a factor of roughly 4 (Yuan et al, 2002).
  - Ability to fit size, complexity, and cost of system to needs of user.
    - A small 100-250 L collection bucket can be used for gardening purposes or a large system with over 10,000 L in storage capacity can be installed to supply water for irrigation, toilet flushing, or drinking water.

### ***Potential Risks and Considerations***

- Steps must be taken to ensure the water quality of any rainwater harvesting system, especially those that will be used for drinking water. Rainwater systems may have microbial or chemical contamination. The physical qualities of the water must also be taken into account.
  - Microbial contamination may occur due to fecal material from animals (such as birds) entering the storm water tanks and entry of small animals in the tank. This contamination can lead to bacteria, protozoa, or viruses entering the water and infecting humans. While this risk is low there have been documented cases of Campylobacter and Salmonella outbreaks associated with rainwater collection systems. Upon investigation poor tank design and/or maintenance were found to have contributed to these contaminations (enHealth, 2004).

- Chemical contamination of rainwater storage tanks is associated with urban traffic, industrial emissions, pesticide over-spraying, or the presence of hazardous chemicals in the roof catchment area (such as lead) (enHealth, 2004)
  - Urban traffic and industrial emissions are unlikely to affect the quality of rainwater in most areas. However, there have been cases when high lead content were associated with large nearby factories. Because of this the residents in that area were advised not to use storm water for drinking or food processing. Steps should be taken to ensure any rainwater collection system installed is not at risk of this contamination (enHealth, 2004).
- Steps must be taken to ensure the physical quality of rainwater (appearance, odor, taste) due to possible sediment or organic material that may enter the system. This is usually done through filtering and disinfecting the rainwater (Cross and Duncan, 2007).
- Because of the unpredictable nature of rainwater, appropriately sized storage tanks need to be installed. These tanks must have an outflow in case the system collects more water than the tank can hold, or else the tank would overflow. Additionally any application of the rainwater should have a back-up water source in case the storage tank runs out of rainwater. The most efficient systems keep the tank as low as possible without running out of water so that the most rainwater is captured when it does rain (Chilton et al, 2000).
- The size of the storage tank installed in a rainwater harvesting system plays a large part in the cost effectiveness of the system. While a larger tank may collect more rainwater over its lifetime, the savings associated with the extra water may not always be worth the extra cost of the tank. For example, in one study the payback period of a rainwater harvesting system could have been reduced from 12 to 4 years if the system had been sized appropriately (Chilton et al, 2000). Therefore when constructing rainwater harvesting systems it is important to size the storage tank correctly.

## ***Estimated Costs***

- The 2009 study in Brasilia Brazil analyzed the feasibility of 3 rainwater harvesting systems with roof catchment areas of 350 m<sup>2</sup>, 550 m<sup>2</sup>, and 750 m<sup>2</sup>. The systems cost US \$2,852, US \$4,315, and US \$5,366 to install. The monthly savings on the station water bills were US \$63, US \$104 and US \$79 respectively. The 350 m<sup>2</sup> system had a payback period of 7.8 years and the 550 m<sup>2</sup> system a payback period of 13.8 years. The 750 m<sup>2</sup> had a negative net present value and therefore did not have a payback period (Ghisi et al, 2009).
- The 2008 study in Arlington, VA, USA found that two proposed rainwater harvesting systems would cost US \$178,800 and US \$179,424 and would provide an annual water bill saving of US \$20,041 and US \$22,054. However, when a net present value (NPV) analysis of the systems was compiled it was found that the NPV of the systems were US \$-105,374 and US \$-54,246. However, it was found that if a 1% premium price was applied to the retail space for its “green profile” for the first 5 years of operation the NPV of the buildings becomes US \$267,012 and US \$77,525.00 respectively (Hicks, 2008).
- According to a report published in 2007 by the Hunter Central Coast Regional Environmental Management Strategy in Australia the approximate cost of various sized rainwater storage tanks are shown in the Figure 4.

Material	Capacity <sup>1</sup> (litres)		
	2,000	4,500	9,000
Concrete (above ground)	\$1,000	\$1,400	\$2,000
<b>Metal:</b>			
Aquaplate™ or Zinalume™	\$450	\$540	\$860
<b>Plastic</b>			
Round or oval	\$650	\$910	\$1,530
Slim line	\$1,200 - \$2,600	\$2,600 - \$5,400	\$5,200 - \$10,000
Bladder	\$1,850	\$2,250	\$3,100
Underground	\$1,990 \$2,850	– \$3,250 – \$4,000	\$5,780 – \$7,000

<sup>1</sup> Actual tank sizes vary by up to 500 litres from these capacities depending on the make

**Figure 25: Australian Rainwater Storage Tank Prices (Cross and Duncan, 2007)**

- The rainwater harvesting system used in the 2006 study in Florianopolis, Brazil required an installation cost on US \$2,100 dollars. The study found that according to Brazilian water prices at the time the payback period for two of the apartments would be 2.4 and 5.0 years due to monthly savings of US \$74 and US \$35. The third apartment block had no monthly savings. (Ferreira and Ghisi, 2006).
- According to a 2005 report in Texas the cost of rainwater harvesting tanks can be (Krishna et al, 2005):
  - US \$0.30-4.00/gal for the storage tank
  - US \$0.30-12.00/ft of gutter
  - US \$200-500 per pump
  - US \$20-3,000 for filters and disinfection systems
- The 2005 case study in Palhoca, Brazil observed that the two rainwater harvesting systems cost US \$1131 and US \$1410 to install and operate. This resulted in annual water savings of US \$53 and US \$19. It should be noted that the saving would have been higher for the houses had it not been for a minimum tariff that the water utility charges (Ghisi and Oliveira, 2006).

- The 1999 case study in Thamesmead, UK found that the rainwater harvesting system in place had a payback period of 12 years and an annual water savings of approximately US \$1,264 according to 1997/98 UK water prices. However, the study noted that the storage tank installed was larger than necessary (14.56 m<sup>3</sup>) and that if the entire roof had been used as a catchment area and a 10 m<sup>3</sup> storage tank used the payback period would have been approximately 4 years (Chilton et al, 2000).

### ***Recommended Site Characteristics***

- Rainwater harvesting systems can be installed anywhere where rainfall can be captured and used as a source of non-potable water.
  - The most effective places for rainwater harvesting systems to be used for everyday use have consistent rainfall, as the rainwater storage tanks then do not have to store as much rainwater and can be smaller which reduces capital costs (see Stantec employee interviews)
  - In arid areas rainwater harvesting can provide a much needed source of water for application such as irrigation by collecting water when it rains during the rainy season and conserving it until the dry season.
- Due to consistent rainfall the South East United States can save a significant amount of water (see Stantec employee interviews).

### ***Potential LEED Credits***

The following is a list of potential LEED points that can be obtained through the use of rainwater harvesting systems.

- LEED Credit SS-C6.1 Stormwater Design - Quantity Control
- LEED Credit SS-C6.2 Stormwater Design – Quality Control

- LEED Credit WE C1.1 Water Efficient Landscaping
- LEED Credit WE C1.2 Innovative Wastewater Technologies
- LEED Credit WE C1.3 Water Use Reduction

## ***Relevant Stantec Projects***

### **1. Southface Eco Office**

Location: [Atlanta, Georgia](#), USA

Description: Stantec provided mechanical and electrical engineering for a 10,000 SF office building that utilized rainwater harvesting for toilet flushing, site irrigation and evaporative condensing. The building requires 75% less water than a typical office building. The project is LEED platinum certified.

Link: [http://marketingexcellence/projectprofile\\_preview.aspx?id=10&project=9729](http://marketingexcellence/projectprofile_preview.aspx?id=10&project=9729)

### **2. Ratna Ling Wellness Center**

Location: [Cazadero, California, USA](#)

Description: Stantec is provided mechanical, electrical, and plumbing engineering design services for a wellness center that includes a rainwater harvesting system. The project aims to attain LEED platinum status.

Link: [http://marketingexcellence/projectprofile\\_preview.aspx?id=10&project=18188](http://marketingexcellence/projectprofile_preview.aspx?id=10&project=18188)

### **3. TELUS Building**

Location: Ottawa, Ontario, Can

Description: Stantec provided mechanical and electrical services for a 156,000 square foot, eight-storey office building that included a rainwater harvesting system to help attain LEED silver status (building is registered but has not yet been granted LEED status).

Link: [http://marketingexcellence/projectprofile\\_preview.aspx?id=10&project=11696](http://marketingexcellence/projectprofile_preview.aspx?id=10&project=11696)

#### **4. Grand Bay National Estuarine Research Reserve**

Location: [Moss Point, Mississippi, USA](#)

Description: Stantec provided mechanical services for a [17,000 SF research center that utilized extensive](#) rainwater harvesting for toilet flushing and site irrigation. The project is targeting LEED gold status.

Link: [http://marketingexcellence/projectprofile\\_preview.aspx?id=10&project=8628](http://marketingexcellence/projectprofile_preview.aspx?id=10&project=8628)

#### **5. WestJet Campus Office Building**

Location: [Calgary, Alberta, Can](#)

Description: Stantec provided structural, mechanical and electrical engineering services, along with architecture, interior design, and planning and landscape architecture for a 6 story 29,212 m<sup>2</sup> office building that included rainwater harvesting used for landscape irrigation. The project is targeting a LEED gold status.

Link: [http://marketingexcellence/projectprofile\\_preview.aspx?id=10&project=16067](http://marketingexcellence/projectprofile_preview.aspx?id=10&project=16067)

#### **6. Zone 4 Field Operations Center**

Location: Charlotte, North Carolina, USA

Description: Stantec provided support services for a local architectural firm, C-design, Inc, including preliminary site planning, graphical services, schematic design, design development, and construction documents relating to landscape architecture. The project was a little over 11 acres located in Charlotte, North Carolina. The Zone 4 Field Operations Center for Charlotte-Mecklenburg Utilities is pursuing a LEED Building Certification Rating of Gold through the incorporation of principles of water efficiency, sustainable sites, materials and resources, and indoor air quality and energy. Rainwater harvesting and water conservation influenced the



overall design through a building form that collects rainwater to one end of the roof line and then harvests it into an underground cistern.

Link: [http://marketingexcellence/projectprofile\\_preview.aspx?id=10&project=18991](http://marketingexcellence/projectprofile_preview.aspx?id=10&project=18991)

## Sources

1. Cross, Hugh and Duncan, Kim. "RAINWATER TANKS." Hunter Central Coast Regional Environmental Management Strategy. 2007. Accessed 1/19/2010.  
[http://www.huntercouncils.com.au/environment/products/downloads/water/Practice\\_Notes/No4\\_Rainwater%20tanks.pdf](http://www.huntercouncils.com.au/environment/products/downloads/water/Practice_Notes/No4_Rainwater%20tanks.pdf)

*This is a guide on the process of installing rainwater harvesting storage tank.*

2. Hicks, Bill. "A Cost-Benefit Analysis of Rainwater Harvesting at Commercial Facilities in Arlington County, Virginia." Duke University. 2008. Accessed 1/27/2010.  
[http://dukespace.lib.duke.edu:8080/dspace/bitstream/10161/512/1/MP\\_wdh11\\_a\\_200805.pdf](http://dukespace.lib.duke.edu:8080/dspace/bitstream/10161/512/1/MP_wdh11_a_200805.pdf)

*This is a master's thesis that considers the cost feasibility of a rainwater harvesting system for two commercial buildings in Arlington County Virginia.*

3. Chilton, J.C et al. "Case study of a rainwater recovery system in a commercial building with a large roof." Science Direct, The University of Nottingham, Nottingham, UK, South Bank University, London, UK, Safeway Stores PLC, Middlesex, UK, and Gerald Tobias Associates, West Sussex UK. April 12<sup>th</sup>, 2000. Copyright © 2000 Elsevier Science Ltd. Accessed 1/20/2010. Available at Sciencedirect.com.

*This source is a case study on a supermarket in Thamesmead, London that installed a rainwater harvesting system.*

4. Ghisi, EneDir et al. "Potential for potable water savings by combining the use of rainwater and grey water in houses in southern Brazil." Science Direct and Federal University of Santa Catarina, Florianópolis, Brazil. February 6<sup>th</sup> 2006. Copyright © 2006 Elsevier Ltd. Accessed 1/20/2010. Available at ScienDirect.com.

*This is a case study of two houses in Southern Brazil that used rainwater harvesting systems, and grey water reuse systems, and systems using both rainwater harvesting and a grey water reuse system to investigate and compare the efficiency of each system.*

5. Ghisi, EneDir et al. "Rainwater harvesting in petrol stations in Brasília: Potential for potable water savings and investment feasibility analysis." Science Direct and Federal University of Santa Catarina, Department of Civil Engineering, Laboratory of Energy Efficiency in Buildings, Campus Universitario, Trindade, CTC, ECV, Florianópolis - SC, 88040-900, Brazil. July 31<sup>st</sup> 2009. Copyright Elsevier B.V 2009. Accessed 1/27/2010. Available at ScienDirect.com.

*This is an article on the feasibility of using rainwater harvesting in Brazil for car washing.*

6. Ghisi, EneDir and Ferreira, Daniel F. "Potential for potable water savings by using rainwater and grey water in a multi-storey residential building in southern Brazil." Science Direct and Laboratory of Energy Efficiency in Buildings, Department of Civil Engineering, Federal University of Santa Catarina, Florianópolis-SC, 88040-900, Brazil. Copyright Elsevier Ltd 2006. July 20 2006. Accessed 1/27/2010. Available at ScienDirect.com.

*This is a study on the ability of 3 blocks of apartment building to use both rainwater harvesting and grey water reuse to reduce their potable water demands in Florianópolis, Brazil.*

7. "GUIDANCE ON USE OF RAINWATER TANKS." enHealth and the National Public Health Partnership. Copyright Australian Government 2004. Accessed 1/28/2010. [http://enhealth.nphp.gov.au/council/pubs/pdf/rainwater\\_tanks.pdf](http://enhealth.nphp.gov.au/council/pubs/pdf/rainwater_tanks.pdf)

*This is a report on the use of grey water tanks that was produced by the Australian government.*

8. Nolde, Erwin. "Possibilities of rainwater utilization in densely populated areas including precipitation runoffs from traffic surfaces." Science Direct and *Technical University of Berlin, Amrumer Strasse 32, D-13353 Berlin, Germany. October 8 2006. Copyright Elsevier B.V 2004. Accessed 1/28/2010. Available at Sciencedirect.com.*

*This is an article on the rainwater management of Berlin. The city diverted rainwater to a treatment plant in order to prepare it for toilet flushing and gardening for 80 apartments and 6 small trade units. The rainwater used came 63% from roofs, 35% from courtyards and sidewalks, and 12% from traffic surfaces. The rainwater is treated using a first flush filter, a biological "planted" substrate filter, and UV disinfection.*

9. Yuan, Tian et al. "Economic analysis of rainwater harvesting and irrigation methods, with an example from China." Science Direct, Lanzhou University, and Gansu Agricultural University. November 11<sup>th</sup> 2002. Copyright Elsevier Science B.V. 2002. Accessed 1/28/2010. Available at Sciencedirect.com.

*This is a study of the economic feasibility of using rainwater to irrigate crops in the semi-arid region Gansu, China.*

10. Zhang, Dongqing. "Reuse-oriented Decentralized Wastewater Treatment based on Ecological Sanitation in fast growing Agglomerations." TU Dortmund University. September 2008. Accessed 1/26/2010. <http://dspace.hrz.uni-dortmund.de:8080/dspace/bitstream/2003/25845/1/Zhang.pdf>

*This is a dissertation by a student in China examining water management strategies in Beijing.*

## Constructed Wetlands

A constructed wetland is a constructed wetland that is designed to exploit and optimize the natural biological processes that occur in natural wetlands to treat wastewater (Rousseau et al, 2008). The idea of constructed wetlands was developed in Germany in the late 1960s and refined in the 1970s (Vymazal, 2005). The first constructed wetland that was installed to treat municipal wastewater was constructed and put into operation in 1974 (Vymazal, 2005). However, the use of constructed wetlands did not begin to gain popularity until the mid 1980s in Europe and were not introduced to North America and Australia until the late 1980s (Vymazal, 2005). Currently as many as 50,000 constructed wetlands have been implemented in Germany, 1,000 in Austria, 800 in the UK, and 8,000 in North America (Vymazal, 2005). Due to the lower required capital costs constructed wetlands will likely continue to be an attractive wastewater treatment option for rural municipalities.

Stantec can take advantage of the expansion of constructed wetlands by positioning themselves as a leader in the design and innovation of constructed wetland design. For example, Stantec employees are experimenting with the use of shredded tires to serve as a substitute to gravel media. This innovation could potentially lead to a sustainable use of old tires as well as reduce the need to transport gravel media to constructed wetland sites. By leading the way in the field Stantec could provide potential clients a means to help construct more sustainable and lower maintenance wastewater treatment systems than other potential bidders.

### Constructed Wetlands

- Cost:
  - The cost of installing a constructed wetland varies greatly because the cost of factors such as local labor and land varies from site to site.
  - In 1996 the estimated capital cost of constructed wetlands ranged from \$25,000–\$250,000 per ha.

- Benefits:
  - Used as a low energy cost effective way to treat wastewater.
  - Provides a wildlife habitat where one might not have previously existed.
- Risks:
  - Correctly designed wetland hydrology greatly affects the effectiveness of the wetland.
  - An overflow of a constructed wetland will negatively affect its efficiency due to a washout of solids.
  - Constructed wetlands typically require larger areas of land than traditional wastewater treatment plants.

### ***Technical Description***

Constructed wetlands are wetlands that have been constructed to treat wastewater. This is done by subjecting the water to wetland vegetation, soils, and microbial assemblages, which will treat the wastewater through natural processes such as aerobic and anaerobic digestion (Vymazal, 2005).

There are three main types of constructed wetlands. They are surface flow (SF) wetlands (also known as free water surface wetlands), subsurface flow (SSF) wetlands, and vertical flow (VF) wetlands. SF wetlands are when a reed bed is placed into the ground and water is allowed to collect in a shallow body of water in the reed bed (Ghermandi, 2007). A SSF wetland is when a plant bed is fed water at one end and allowed to percolate through the subsurface to the other side due to a slight incline (Yocum, 2007). A VF wetland is when water is fed to the wetland from the surface and allowed to percolate downward into the soil and is then removed as a deeper depth (Brix and Arias, 2005). Figure 1 shows an example of a SF, SSF, and VF wetlands.

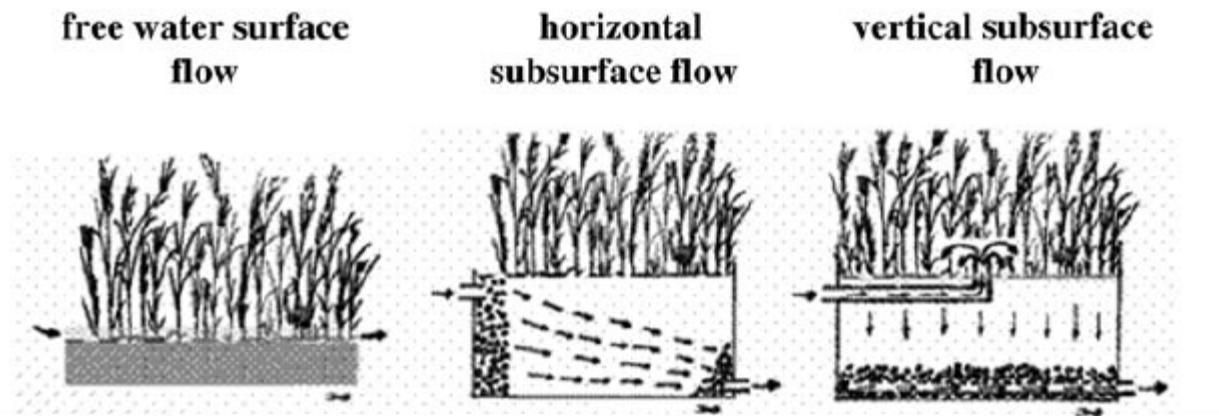

Figure 26: The Difference Between ST, SSF, and VF Wetlands (Ghermandi, 2007)

By using constructed wetlands to treat wastewater before it is discharged directly into the natural environment harmful contaminants can be contained. This is to prevent the discharge of harmful pollutants such as pathogens, minerals and dissolved solids, heavy metals, and organic contaminants into the natural habitat (Ghermandi et al, 2008). Constructed wetlands also help reduce the need for potable water, as water from a constructed wetland can be used to irrigate plants, flush toilets, or cleaning purposes (Rousseau et al 2008).

Constructed wetlands are especially attractive for small municipalities that need a low cost alternative to traditional secondary wastewater treatment options (Cardoch et al, 2000). These wetlands can be a lower energy option than other wastewater treatment options (Zhang et al, 2009). Wetlands are also said to provide social benefits by providing a place for education (for nature study) and recreational activities such as walking, jogging, hunting, and picnicking (Rousseau et al, 2008).

The biggest drawback to using constructed wetlands for wastewater treatment is securing enough land for the wetland. Therefore constructed wetlands are often used as a low cost low energy alternative to mechanical treatment plants in rural areas where the cost of land is less (Cameron et al, 2003). Constructed wetlands also provide a wildlife habitat that would otherwise not exist and therefore promotes greater



biodiversity in a region (Greenway, 2005). Other potential drawbacks that need to be considered are the potential for wetland overflow, the potential for mosquitoes to breed in the wetland, odor control, and the negative effect of lower temperatures on the wetlands effectiveness.

## ***Potential Benefits***

1. Can be used to treat wastewater to a high enough quality for discharge or other applications (see below for examples). This can help to reduce pollution and groundwater contamination The following contaminants can be treated or removed by constructed wetlands:
  - Biochemical oxygen demand (BOD)
  - [Chemical oxygen demand](#) (COD)
  - Fecal coliforms
  - E coli
  - Total Suspended Solids (TSS)
  - Total Phosphorus (TP)
  - Total Nitrogen (TN)
  - Heavy metals
- Can be an energy efficient way to treat wastewater compared to traditional methods. For example a 2001 study in China found that a constructed wetland system needed 72-83% less energy than traditional wastewater options for three villages (Zhang et al, 2009).
- Can provide a low capital cost option to smaller municipalities that may not be able to afford expensive secondary treatment plants (Cardoch et al, 2000).
- Provides a wildlife habitat where one might not have previously existed (Greenway, 2005).

- Can provide passive recreational benefits for community (Greenway, 2005) as well as social benefits by providing a place for activities such as walk or jogging (Rousseau et al, 2008).

### ***Potential Risks and Considerations***

- Proper permits are needed in order to construct a constructed wetland.
- When designing it is very important to correctly design the wetlands hydrology, as the wetlands residence time will dictate how effective it is treating the water (see Stantec employee interviews).
- Wetlands may not operate at consistent purification rates due to factors such as temperature and water PH.
  - Cold months can slow nitrogen cycling due to lower availability of oxygen (Zhang et al, 2009).
  - If wetland freezes microbial decomposition may decrease (Zhang et al, 2009).
  - A 2006 study in China found that BOD and COD removal were 10% less efficient in winter than in summer (Zhang et al, 2009)
- The macrophytes that are used in a wetland can make a difference in the effectiveness of the system and multiple varieties should be used for maximum efficiency of the wetland (Greenway, 2005).
- An overflow of a constructed wetland will negatively affect its efficiency due to a washout of solids (Rousseau et al, 2006).
- Constructed wetlands typically require larger areas of land than traditional wastewater treatment plants.
- Constructed wetlands can be a potential breeding ground for mosquitoes if stagnant water is present. Because of this SSF wetlands typically have a lower risk of mosquitoes than SF or VF wetlands (Rousseau et al, 2006).

- “The risk of extensive mosquito breeding can be reduced by designing a wetland with at least 30% open water, a wide diversity of plant species, and sections of both deep open water ponds and shallow marshes” (Greenway, 2005)
- Odor can become an issue if a wetland is overloaded and anaerobic conditions become prominent. The addition of shallow basins or implementation of cascading outfall structures can help prevent this odor from becoming an issue (Rousseau et al, 2006).
- SSF wetlands are susceptible to clogging if the wetland is not properly maintained (Rousseau et al, 2006).

### ***Estimated Costs***

- The cost of installing a constructed wetland varies greatly because the cost of factors such as local labor and land varies from site to site (See Stantec employee interviews)
- Maintenance for a constructed wetland is typically very low and can be as simple as inspecting the wetlands dikes for water animals periodically and harvesting the wetlands vegetation every 3 to 5 years (see Stantec employee interviews).
- A 2006 study in Spain found that the average cost of a Horizontal Flow (SF and SSF) wetland was US \$638 per equivalent person, the cost of a VF wetland was US \$374 per equivalent person, and the average cost of a hybrid system was US \$279 per equivalent person (Puigagut et al, 2007).
- A 2004 report produced in Flanders, Belgium found that the average capital cost for SF wetland was of US \$479 per equivalent person (Rousseau et al, 2008).
- A 1996 report produced in Florida found that the average capital cost of a constructed wetland is \$25,000–\$250,000 per ha (\$500-\$1,000 per m<sup>3</sup>). The report also states that the median cost for the operation and maintenance of a SF wetland

is about US \$1,000 per ha per year and the operation and maintenance cost of a SSF wetland is US \$2,500 and \$5,000 per ha per year (Rousseau et al, 2008).

### ***Recommended Site Characteristics***

- SF wetlands have a higher evaporation than SSF or VF wetlands and therefore are suitable for non-discharge wetlands (see Stantec employee interviews).
- SSF and VF wetlands are more effective at removing solids and organic material in wastewater, and so are more applicable to discharge wetland applications (see Stantec employee interviews).
- Constructed wetlands are more economical in areas where land is less expensive and more available due to the land requirements of constructed wetlands (Zheng et al, 2009).
- Constructed wetlands tend to be more effective in warmer climates (Rousseau et al, 2006).
- Constructed wetlands are often attractive to smaller communities due to the prohibitive costs of a traditional wastewater treatment options (Greenway, 2005).

### ***Surface Flow (SF) Wetlands***

Surface flow (SF) or free water surface wetlands typically consist of multiple open cells with shallow lagoons that have macrophytes in them (Greenway, 2005 and Hadad et al, 2006). These macrophytes absorb pollutants directly as well as promote chemical and biochemical reactions that help purify the wastewater (Hadad et al, 2006). A typical layout for a SF wetland is shown in Figure 27.

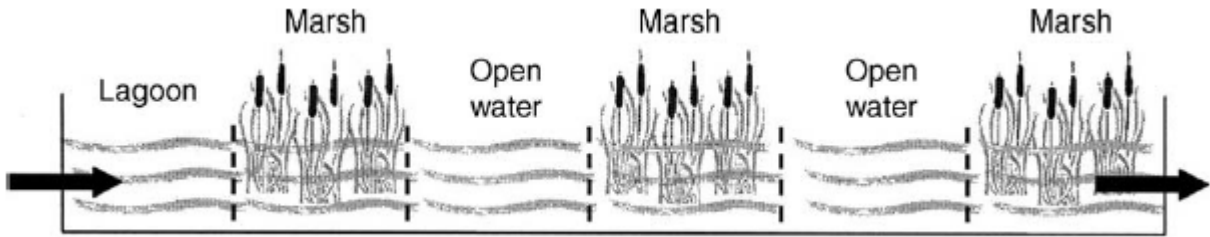

Figure 27: Example of SF Wetland Layout (Greenway, 2005)

### Potential Benefits of SF Wetland

- A 2000 study in Brisbane, Australia, found that four SF wetlands reduced fecal coliforms in wastewater by 98.7%, 96.4%, 99.6%, and 99.6% (Greenway, 2005).
- A 2005 study conducted by the School for Advanced Studies in Venice Foundation and Aquafin NV Dijkstraat compiled the results of numerous case studies. The effectiveness of the systems studies in those case studies are shown in Table 19. The results of the study found that the average BOD removal efficiency was 49.2%, the average TSS removal was 23.1%, and the average total coliform removal was 89% (Ghermandi et al, 2005).

Table 19: Results of 2005 Study by Ghermandi et al

Wetland Location	BOD Removal (%)	TSS Removal (%)	Fecal Coliform Removal (%)
Alfred Municipal Wetland, USA			52
Alexander River, ISR	86	91	
Alhagen, SWE	87		
Arcata, enhanced. Wetlands, USA	58	63	
Arcata, first pilot study, USA	49	85	99.3
Arlington, USA	25	5	
Bentivoglio, ITA		64	
Benton (Cattail), USA	62	81	70

Benton (Woolgrass), USA	52	73	94
Blackall, AUS	43	35	31
Bobbio, ITA	50		99.9
CERF Tucson, USA (Duckweek)			66
CERF Tucson, USA (Multi-species)			99.4
Cannon Beach, USA	78	78	
Carolina Bays, USA	~83	~75	
Cobalt 1, CAN	78	23	
Columbia, Missouri, USA	76	-1	97
Crow Edge, UK			90
De Groote Beerze, NED		11	
Eagle Bluffs, USA			97
Edmonton, AUS	-2	7	96
Ekeby, SWE	-8		
Empuriabrava, SPA			97
Elburg, NED	40	33	
Eversteekoog, NED			94
Fort Deposit, USA	79	87	
Hillsboro, USA	41	-25	
Houghton Lake, USA		60-80	
Huntly, NZ	59	73	
Ingham, AUS	30	33	
Iron Bridge, USA	28	-1	
Johnson City 2, USA	45	66	
Lakeland, USA	20	16	99.6
Lanai WRF, Hawaii, USA			89
Land van Cuijk, NED		62	
Listowel (cell 2+3), CAN	55	41	88
Mackay, AUS	22	-139	
Magle, SWE	-89	-73	
Manila Community Treatment Plant, USA	68	88	
Martinez, Mt View, USA	11	-203	
Nakivubo, Uganda (Cyperus Papyrus)			99.1

Nakivubo, Uganda (Miscanthidium)			94
Ostellato, ITA	22-25		99.7
Oxeloesund, SWE	82		
Sacramentoa Demonstration Proj, USA	73	-30	
Seneca Army Depot, USA	74	-30	98
Silver Spring Shres, Lake Coral, USA	78	75	
Te Keuwahata, NZ	76	84	
Townsville, AUS	67	66	99.5
West Jackson Co, USA	71	66	
Williamstown, IRE	49	84-90	99.8
<b>Average</b>	<b>49.6</b>	<b>23.1</b>	<b>89</b>

- A 2000 study conducted in Alfred, Ontario found that a three cell SF wetland consisting of a marsh-pond-marsh setup was able to purify the wastewater by the following amounts (Cameron et al, 2003):
  - BOD by 34%
  - Fecal coliforms by 52%
  - E. coli 58%
  - TSS by 93%
  - TP by 90%
  - TKN by 37%
  - NH4 by 52%
  - o-PO4 by 82%
- A 2005 case study in Santo Tome´, Santa Fe, Argentina found that a SF wetland could treat 1000 L per day and reduce (Brix and Arias, 2005):
  - BOD by 76%
  - COD by 79%
  - TS by 32%

- Iron by 83%
  - Chromium by 82%
  - Nickel by 89%
  - Zinc by 55%
- A 2009 study on the state of constructed wetlands in China found that on average 7 SF wetlands that treated up to 1,800 m<sup>3</sup>/day reduced (Zhang et al, 2009):
  - BOD by 66.1%
  - COD by 38.1%
  - TSS by 83.5%
  - TP by 53.2%
  - TN by 49.1%
- A 2007 study in Crete found that two 33 m<sup>2</sup> SF wetlands that could treat 12.6 m<sup>3</sup>/day and 6.3 m<sup>3</sup>/day of highway runoff could reduce (Manios et al, 2009):
  - COD by 40% and 45%
  - TSS by 85% and 88%
  - TN by 44% and 47%
  - TP by 54% and 60%

### **Estimated Costs of SF Wetland**

- The 2007 study in Crete found that the SF wetlands that could treat 12.6 m<sup>3</sup>/day and 6.3 m<sup>3</sup>/day of highway runoff both had a capital cost of US \$19,970.00 (Manios et al, 2009).
- A 1999 study in Dulac, LA found that a 1 acre SF wetland that could process 150,000 Gal/day would cost either US \$63,000 per year of operation (including capital costs) (Cardoch et al, 2000).
- A 1995 case study in Tianjin city China found that a SF wetland that could treat 2,000 m<sup>3</sup>/day of wastewater had a total capital cost of US \$41,176.00 (~US



\$20.00/m<sup>3</sup>) and had an operation and maintenance cost of US \$0.031/m<sup>3</sup> (Zhang et al, 2009).

- A 1995 case study in Wei Fang, Shangdong province, China found that a SF wetland that could treat 180,000 m<sup>3</sup>/day of wastewater had a capital cost of US \$102.00/m<sup>3</sup> of wastewater treated and had an operation and maintenance cost of US \$0.021/m<sup>3</sup> (Zhang et al, 2009).

### ***Subsurface Flow (SSF) Wetlands***

A subsurface flow (SSF) wetland is a wetland that treats wastewater by allowing water to flow through a bed of vegetation, often a reed bed. As wastewater passes through this bed it comes into contact with aerobic, anoxic and anaerobic zones which treat the water (Vymazal, 2005). The water in the system is typically contained by some type of waterproof barrier around the edges and bottom of the bed (Yocum, 2007). The bed is typically on an incline to help the water percolate through the system and prevent overflow (Yocum, 2007) a typical layout for a SSF system is shown in Figure 28.

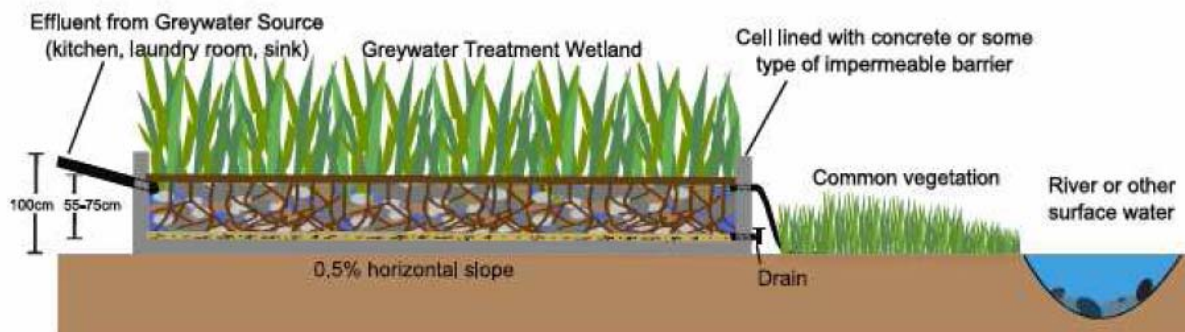

Figure 28: Typical Layout of a Subsurface Flow Constructed Wetland (Yocum, 2007)

### **Potential Benefits of SSF Wetlands**

- A subsurface flow constructed wetland constructed on Lopez Island, Washington in late 2006 and put planted with vegetation in spring 2007 was used to polish effluent from a lagoon treatment system (Li and Holmes 2010).
  - The constructed wetland was 1147 m<sup>2</sup> and could treat 157 m<sup>3</sup>/day of water (Li and Holmes 2010).
  - The wastewater plant was found to typically reduce (Li and Holmes 2010):
    - COBD<sub>5</sub> to less than 5 mg/L
    - TSS to less than 5 mg/L
    - FC to a maximum weekly 400 cfu/100 ml
    - FC to a maximum monthly 200 cfu/100 ml
  - The wetland utilized shredded tire chips to account for 70% of typical volume of gravel media (Li and Holmes 2010).
    - Using shredded tire chips helped reduce the cost of the project, as gravel was more expensive than tire chips.
    - Old tire were disposed of in an environmentally friendly way by using the shredded tire chips.
  - The wetland provided a habitat for local wildlife such as sparrows (Li and Holmes 2010).
- A 2005 study conducted at Duke University that compiled field results from Australia, Austria, Brazil, Canada, Czech Republic, Denmark, Germany, India, Mexico, New Zealand, Poland, Slovenia, Sweden, USA and UK found that SSF wetlands produced the results shown in Table 20.

**Table 20: Typical SSF Efficiencies (Vymazal, 2005)**

Parameter	Inflow	Outflow	Removed	Efficiency (%)	<i>N</i>
BOD <sub>5</sub>	39.2 <sup>a</sup>	7.6 <sup>a</sup>	31.6 <sup>a</sup>	81	131
COD	120 <sup>a</sup>	34.6 <sup>a</sup>	85.4 <sup>a</sup>	71	110
TSS	53.6 <sup>a</sup>	11.6 <sup>a</sup>	42.0 <sup>a</sup>	78	130
TP	141 <sup>b</sup>	96 <sup>b</sup>	45 <sup>b</sup>	32	104
TN	644 <sup>b</sup>	394 <sup>b</sup>	250 <sup>b</sup>	39	113
NH <sub>4</sub> <sup>+</sup> -N	388 <sup>b</sup>	255 <sup>b</sup>	133 <sup>b</sup>	34	90
NO <sub>3</sub> <sup>-</sup> -N	98 <sup>b</sup>	67 <sup>b</sup>	31 <sup>b</sup>	32	66

<sup>a</sup> Values in kg ha<sup>-1</sup> day<sup>-1</sup>.

<sup>b</sup> Values in g m<sup>-2</sup> year<sup>-1</sup>.

- A 1999 study in Texas tracked the water quality of effluent from 8 subsurface wetlands for 2 to 4 years each. The effluent was detained in the wetlands for 2 days during which time the wetland reduced the waters BOD 80-90%, TSS 81%, fecal coliforms 90-99%, and Ammonium 40% (Neralla et al, 2000).
- A 1999-2004 study conducted in Rongcheng, Shandong Province, China found that a subsurface flow wetland reduced pollutants by (Song et al, 2005):
  - BOD by 70%
  - COD by 62%
  - Fecal coliform by 99.6%
  - Total coliform by 99.7%
  - SS by 78%
  - Total phosphorus by 30%.
  - Ammonia nitrogen by 40%
- A SSF wetland constructed in 2005 on the Longdao River in Beijing that had the ability to treat 200 m<sup>3</sup> a day was found to reduce (Zhou et al, 2007):
  - BOD by 82.9%
  - COD by 71.4%
  - TSS by 73.0%
  - TP by 95.0%
  - TN by 92.5%

- A 2009 study on the state of constructed wetlands in China found that on average 8 SSF wetlands that treated up to 50,000 m<sup>3</sup>/day reduced (Zhang et al, 2009):
  - BOD by 88.2%
  - COD by 70.1%
  - TSS by 75.5%
  - TP by 59.0%
  - TN by 56.1%
  - NH<sub>4</sub> by 64.6%
- A 2007 study in Crete found that two 32 m<sup>2</sup> SSF wetlands that could treat 12.6 m<sup>3</sup>/day and 6.3 m<sup>3</sup>/day of highway runoff could reduce (Manios et al, 2009):
  - COD by 49% and 52%
  - TSS by 91% and 92%
  - TN by 50% and 57%
  - TP by 60% and 66%

### **Estimated Costs of SSF Wetlands**

- The 2007 study in Crete found that the SSF wetlands that could treat 12.6 m<sup>3</sup>/day and 6.3 m<sup>3</sup>/day of highway runoff both had a capital cost of US \$21,556.00 (Manios et al, 2009).
- The 2006 1147 m<sup>2</sup> subsurface wetland that could treat 157 m<sup>3</sup>/day building on Lopez Island, Washington cost US \$148,000.00 to construct. The maintenance costs of this facility are low (Li and Holmes 2010).
- A SSF wetland constructed in 2005 on the Longdao River in Beijing that had the ability to treat 200 m<sup>3</sup> a day had a capital cost of US \$84.00 per m<sup>3</sup> treated and a US\$ 0.009 per m<sup>3</sup> operation and maintenance cost (Zhou et al, 2007).
- A 2005 case study in Tianjin city China found that a SF wetland that could treat 100,000 m<sup>3</sup>/day of wastewater had a total capital cost of US \$8,200,000.00 (~US

\$82.00/m<sup>3</sup>) and had an operation and maintenance cost of US \$0.012/m<sup>3</sup> (Zhang et al, 2009).

## Vertical Flow (VF) Wetlands

Vertical flow (VF) wetlands consist of a plant bed that is fed water from the ground surface and treats the water as it percolates through the bed. The water is purified because pollutants are removed by microorganisms present in the bed's soil and on the plant roots present in the system (Brix and Arias, 2005). A typical VF wetland setup is shown in Figure 29.

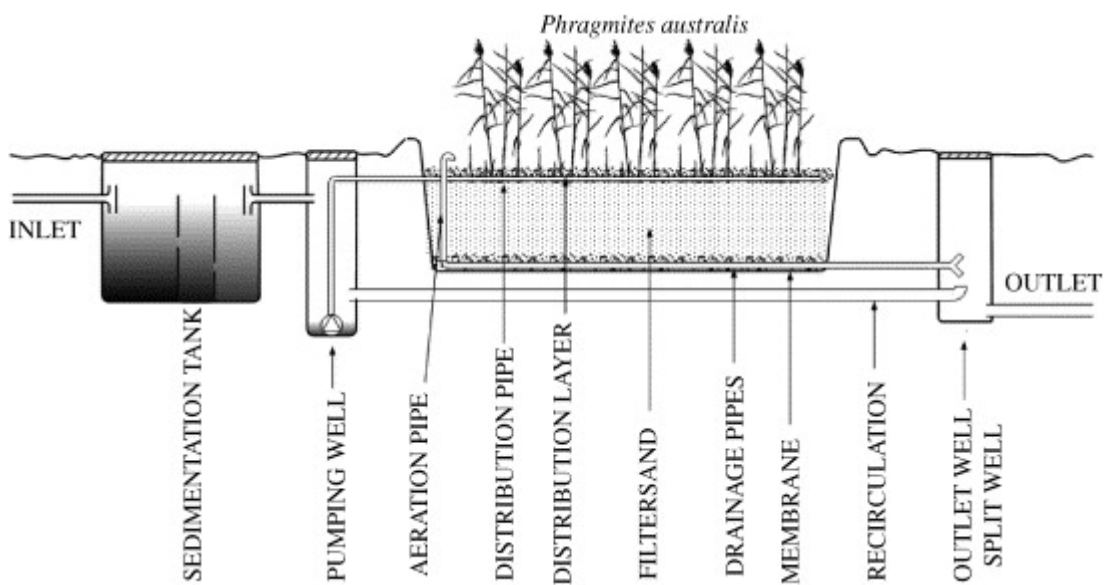

Figure 29: Example of a VF Wetland Layout (Brix and Arias, 2005)

In Figure 30 one can see a VF wetland immediately after construction (on the left) and the same wetland once plant life took hold. This wetland was constructed in Ontario, Canada on a mushroom farm (AQUA Treatment Technologies, 2008). The water that the field treats is collected by a series of hoses and pumps at the bottom of the system.



Figure 30: Finished VF Wetland Before and After Plants Have Grown (AQUA Treatment Technologies, 2008)

## Potential Benefits of VF Wetlands

- A 2005 case study in Denmark found that VF wetlands for single family houses were observed the water quality results presented in Table 21 (Brix and Arias, 2005).

Table 21: Efficiency of VF Wetlands of Single Family Homes (Brix and Arias, 2005)

Performance data (mean $\pm$ 1 S.D.) of some single-house vertical flow constructed wetlands				
System	Parameter	Inlet ( $\text{mg l}^{-1}$ )	Outlet ( $\text{mg l}^{-1}$ )	Removal (%)
VF1 <sup>a</sup> (without recirculation)	TSS	85 $\pm$ 28	8 $\pm$ 3	91
	BOD <sub>5</sub>	254 $\pm$ 123	19 $\pm$ 4	92
	NH <sub>4</sub> -N	105 $\pm$ 45	23 $\pm$ 17	78
	NO <sub>2</sub> + NO <sub>3</sub> -N	<0.1	40 $\pm$ 13	–
	Total-N	125 $\pm$ 51	72 $\pm$ 28	43
	Total-P	17.2 $\pm$ 7.0	13.0 $\pm$ 6.6	25
VF1 (with 100% recirculation)	TSS	68 $\pm$ 22	3 $\pm$ 1	96
	BOD <sub>5</sub>	100 $\pm$ 35	11 $\pm$ 3	89
	NH <sub>4</sub> -N	45 $\pm$ 13	7 $\pm$ 1	85
	NO <sub>2</sub> + NO <sub>3</sub> -N	0.13 $\pm$ 0.09	36 $\pm$ 4	–
	Total-N	57 $\pm$ 13	44 $\pm$ 5	23
	Total-P	5.2 $\pm$ 1.7	5.7 $\pm$ 1.2	0
VF2 <sup>b</sup>	TSS	88 $\pm$ 8	7 $\pm$ 5	92
	BOD <sub>5</sub>	507 $\pm$ 395	7 $\pm$ 2	98
	NH <sub>4</sub> -N	242 $\pm$ 75	59 $\pm$ 11	76
	NO <sub>2</sub> + NO <sub>3</sub> -N	0.1 $\pm$ 0.1	141 $\pm$ 40	–
	Total-N	350 $\pm$ 5	190 $\pm$ 37	46
	Total-P	20.6 $\pm$ 7.5	7.5 $\pm$ 4.8	64
VF3 <sup>c</sup>	TSS	124 $\pm$ 135	4 $\pm$ 3	97
	BOD <sub>5</sub>	320 $\pm$ 139	2 $\pm$ 1	99
	NH <sub>4</sub> -N	18 $\pm$ 22	0.4 $\pm$ 0.2	98
	NO <sub>2</sub> + NO <sub>3</sub> -N	0.5 $\pm$ 0.5	8.0 $\pm$ 2.6	–
	Total-N	30 $\pm$ 23	9 $\pm$ 3	63
	Total-P	4.6 $\pm$ 3.6	4.5 $\pm$ 2.6	2

The inlet samples were taken as grab samples after the sedimentation tank. *Note:* The systems were not constructed and loaded according to the presented guidelines (see text for details).

<sup>a</sup> 15 m<sup>2</sup> system receiving sewage from a household with five persons monitored for a period without recirculation ( $n = 10$ ) and a period with recirculation ( $n = 4$ ) to the first chamber of the sedimentation tank.

<sup>b</sup> 17 m<sup>2</sup> system receiving only grey water from a household with four persons ( $n = 3$ ).

<sup>c</sup> 8 m<sup>2</sup> system receiving only grey water from a household with four persons ( $n = 3$ ).

- A 2006 study in Spain found that the average VF system in Spain reduced both BOD and COD by 92.2% (Puigagut et al, 2007).
- A 2009 study on the state of constructed wetlands in China found that on average 10 VF wetlands that treated up to 2,000 m<sup>3</sup>/day reduced (Zhang et al, 2009):
  - BOD by 83.0%
  - COD by 62.1%
  - TSS by 74.7%
  - TP by 59.2%
  - TN by 43.7%
  - NH<sub>4</sub> by 56.2%

### **Estimated Costs of VF Wetlands**

- A 2007 case study in Hangzhou, China found that a 600 m<sup>2</sup> vertical flow wetland used to treat and reuse water for an ornamental fish pond had a cost benefit ratio of 1.2 according to the contingent value method (Yang et al, 2008).

### ***Hybrid Wetland Systems***

Hybrid wetland systems are when more than one constructed wetland system is used to treat wastewater, usually by staging them. This is done to produce a more complete treatment system (Vymazal, 2005). For example VF systems are typically very poor at removing phosphorous from wastewater (Brix and Arias, 2005), so if phosphorous levels are too high after VF treatment another treatment can be applied. In doing so, more efficient systems can be designed.

## Potential Benefits of Hybrid Wetlands

2. A 2003 study in Nepal found that a SF-VF hybrid system resulted in the treatment efficiency shown in Table 20 (Vymazal, 2005).

Table 22: Results of a SF-VF Wetland System in Nepal (Vymazal 2005)

	ST <sub>in</sub> (mg l <sup>-1</sup> )	ST <sub>out</sub> (mg l <sup>-1</sup> )	HF <sub>out</sub> (mg l <sup>-1</sup> )	VF <sub>out</sub> (mg l <sup>-1</sup> )	Removal (%)
BOD <sub>5</sub>	118	67	25	2	98
COD	261	162	45	10	96
TSS	159	57	19	1.5	99
NH <sub>4</sub> <sup>+</sup> -N	32	32	27	0.1	99
NO <sub>3</sub> <sup>-</sup> -N	0.2	0.2	0.4	27	
TP	4.6	4.4	2.6	1.4	70
<i>E. coli</i>	7.2	6.2	3.6	1.3	5.9 <sup>a</sup>

ST, septic tank; *E. coli* in log<sub>10</sub> CFU/100 ml.

<sup>a</sup> Log units.

3. A 2003 study in Colecott Ireland found that a VF-SF hybrid system resulted in the treatment efficiency shown in Table 20 (Vymazal, 2005).

Table 23: Results of a VF-SF Wetland System in Colecott Ireland (Vymazal, 2005)

Parameter	Inflow	VF1 <sub>out</sub>	VF2 <sub>out</sub>	HF <sub>out</sub>	Efficiency
COD	462	210	66	47	89
BOD <sub>5</sub>	269	171	43	23	91
TSS	53	28	3	1	98
NH <sub>4</sub> <sup>+</sup> -N	45	28	16	7	84
NO <sub>3</sub> <sup>-</sup> -N	0.1	4.7	3.8	2.7	
NO <sub>2</sub> <sup>-</sup> -N	0.1	0.2	0.1	0.1	
PO <sub>4</sub>	18	16	15	11	39

Concentrations in mg l<sup>-1</sup>, efficiency in %.

4. A 2008 case study in Bogota, Colombia found that a hybrid SF-SSF wetland system was able to treat 45 L/min and remove the following pollutants (Brown and Artas, 2009):
- BOD 92%



- E coli 98%
  - SS 97%
  - TP 47%
  - TN 62%
  - NH<sub>4</sub> 62%
5. A 2009 study on the state of constructed wetlands in China found that on average 5 hybrid wetlands that treated up to 5,300 m<sup>3</sup>/day reduced (Zhang et al, 2009):
- BOD by 80.1%
  - COD by 78.5%
  - TSS by 95.0%
  - TP by 79.7%
  - TN by 46.8%
  - NH<sub>4</sub> by 37.4%

### **Estimated Costs of Hybrid Wetlands**

6. The 2008 case study in Bogota, Colombia that could treat 45 L/min was found to cost US \$14,672.00 per year (including capital costs, operation, and maintenance) (Brown and Artas, 2009).

### ***Potential LEED Credits***

The following is a list of potential LEED points that can be obtained through the use constructed wetlands.

- LEED Credit SS-C5.1 Site Development - Protect or Restore Habitat
- LEED Credit SS-C5.2 Site Development – Maximize Open Space

- LEED Credit SS-C6.1 Stormwater Design - Quantity Control
- LEED Credit SS-C6.2 Stormwater Design – Quality Control
- LEED Credit WE C1.1 - Water Efficient Landscaping
- LEED Credit WE C1.2 - Innovative Wastewater Technologies
- LEED Credit WE C1.3 - Water Use Reduction

## ***Relevant Stantec Projects***

### **1. Wildrose Constructed Wetland Stormwater Management**

Location: Edmonton, Alberta, Can

Description: Project consisted of developing a stormwater management strategy prior to discharge into Mill Creek. Part of this management strategy included using the creek to treat the water. This was done by creating sediment ponds at the inlets for runoff speed control, using a large percentage of marsh zones to maximize pollution removal by vegetation, and creating increased retention time to allow for the settlement of solids.

Link: [http://marketingexcellence/projectprofile\\_preview.aspx?id=10&project=17337](http://marketingexcellence/projectprofile_preview.aspx?id=10&project=17337)

### **2. Edgemont Constructed Wetlands**

Location: Calgary, Alberta, Can

Description: Stantec provided the landscape architecture and stormwater engineering design for a naturalized wetland for a previously planned dry pond. The 1.5 hectare (3.7 acre) Edgemont constructed wetland provides treatment for the surface runoff from a 20 hectare (49.5 acre) suburban development. Using an extended storm detention pond, the site provides significant wildlife habitat and sustained sub-surface irrigation to a

floodable forest located within the wetland. Today the pond gives the appearance of a naturally occurring wetland area.

Link: [http://marketingexcellence/projectprofile\\_preview.aspx?id=10&project=5192](http://marketingexcellence/projectprofile_preview.aspx?id=10&project=5192)

### **3. Meadows NH 3 Stage 2 Constructed Wetlands Stormwater Management**

Location: Edmonton, Alberta, Can

Description: The Meadows NH 3 Stage 2 Constructed Wetlands serves primarily to temporarily store stormwater, but has also applied ecological principles to develop an effective, environmentally sound, and affordable option within a suburban development. The design incorporates native wetland plants, shallow marsh areas, complex marsh topography, and water flow routes. On the shorelines, trees and shrubs are planted to control erosion. In addition, passive recreational activities are provided for through a walking trail with bridges and a lookout point. This also provides a valuable marketing tool for the surrounding community.

Link: [http://marketingexcellence/projectprofile\\_preview.aspx?id=10&project=17547](http://marketingexcellence/projectprofile_preview.aspx?id=10&project=17547)

### **4. City of Spring Hill Subsurface Flow Constructed Wetland System**

Location: Stearns County, Minnesota, USA

Description: Stantec designed a subsurface flow constructed wetland system with Forced Bed Aeration™. The treatment system consists of a series of community septic tanks, flow metering, and two 7,000 square foot wetland cells. After treatment, a subsurface drip irrigation system is used for effluent disposal. The drip irrigation area is divided into five time-based drip zones. Stantec designed the drip irrigation system to be a community shelterbelt on the north and west sides of town. The disposal field was planted with a variety of native trees and shrubs to maximize the wildlife

habitat value of the shelterbelt. Specific plant species were selected to maximize water consumption through evapotranspiration. Pre-treated wastewater is recycled through 21,000 linear feet of drip tubing over a total area of approximately one acre.

Link: [http://marketingexcellence/projectprofile\\_preview.aspx?id=10&project=18351#](http://marketingexcellence/projectprofile_preview.aspx?id=10&project=18351#)

### **5. Fort Collins Wastewater Treatment Facility Pilot Wetlands**

Location: Fort Collins, Colorado, USA

Description: Stantec was commissioned to design, build, and operate a pilot scale wetland for denitrification and metals removal. Two subsurface wetlands were constructed to treat effluent from the Drake Water Reclamation Facility. Work included system design, implementation of a sampling program, preparation of specifications, and construction. Nitrate and metals removal from the nitrified secondary effluent through the wetlands was monitored for three years

Link: [http://marketingexcellence/projectprofile\\_preview.aspx?id=10&project=13676](http://marketingexcellence/projectprofile_preview.aspx?id=10&project=13676)

### **6. Larimer County Park WWTF - Wetland at Flatiron Reservoir**

Location: Loveland, Colorado, USA

Description: Stantec evaluated a subsurface constructed wetland system to treat the domestic wastewater from the Larimer County Parks Maintenance Facility. We prepared construction drawings and technical specifications for the new sewage disposal system and additional site utility improvements. A subsurface wetland treatment system was constructed to treat septic tank effluent. Cattails planted in rock media extend their roots into the flow path of the wastewater providing oxygenated surfaces for microorganisms to

grow. Groundwater discharge of treated wastewater from the wetlands occurs via absorption field.

Link: [http://marketingexcellence/projectprofile\\_preview.aspx?id=10&project=7355#](http://marketingexcellence/projectprofile_preview.aspx?id=10&project=7355#)

## **7. National Great Rivers Research and Education Center Field Station Wetland Wastewater System**

Location: Alton, Illinois, USA

Description: The National Great Rivers Research and Education Field Station was interested in a natural system to treat wastewater onsite, provide the option for water reuse, and incorporate water features into their new building. The Stantec project team prepared a feasibility analysis for the use of engineered wetlands for wastewater treatment and reuse for the project. After the costs and sizes of the wetland system were determined, the project team began the design of a two-stage wetland treatment system with ultraviolet disinfection. The wastewater will be treated to a quality that allows for non-potable reuse, including a water feature in the lobby. The wetland wastewater system project is currently in the permitting phase. The building is on track to achieve LEED Gold status.

Link: [http://marketingexcellence/projectprofile\\_preview.aspx?id=10&project=18363](http://marketingexcellence/projectprofile_preview.aspx?id=10&project=18363)

## **8. St. Croix Hertel Wastewater Collection, Treatment, and Disposal System**

Location: Burnett County, Wisconsin, USA

Description: The St. Croix Indian community wanted to connect 81 residents, 6 apartments, and 11 commercial buildings to a centralized wastewater treatment and disposal system. Stantec designed a gravity sewer system with over 30,000 feet of eight-inch gravity sewer and five raw sewage lift stations to collect the wastewater and carry it to a centralized treatment

system. The wastewater will be treated using six subsurface flow constructed wetlands with Force Bed Aeration™ and three single pass sand filters for final polishing. Once the wastewater is treated it is discharged to a large wetland complex.

Link: [http://marketingexcellence/projectprofile\\_preview.aspx?id=10&project=18375](http://marketingexcellence/projectprofile_preview.aspx?id=10&project=18375)

## **9. Fisherman Bay Sewer District Lagoon Facility Improvement**

Location: Lopez Island, Washington, USA

Description: Stantec was hired by the Fisherman Bay Sewer District in 2000 to troubleshoot and recommend solutions and design plans for their failing aerated lagoon system. Stantec conducted a microscopic examination to evaluate the overall health of the lagoons, collected data, and developed and evaluated alternatives for improving the lagoon system in an engineering report. The recommendations to improve the lagoon system consisted of the addition of an anaerobic pretreatment cell, baffles in the aerated lagoon for reduce short-circuiting, and subsurface constructed wetlands for controlling algae in the lagoon effluent.

Link: [http://marketingexcellence/projectprofile\\_preview.aspx?id=10&project=7058](http://marketingexcellence/projectprofile_preview.aspx?id=10&project=7058)

## Sources

1. Arias, Mauricio E. and Brown, Mark T. "Feasibility of using constructed treatment wetlands for municipal wastewater treatment in the Bogotá Savannah, Colombia." University of Florida. March 24th 2009. Copyright Elsevier B.V. 2009. Accessed 2/1/2010. Available at Sciencedirect.com.

*This article accessed the feasibility of a constructed wetland treatment system for Bogotá Savannah, Colombia.*

2. Brix, Hans and Arias, Carlos A. "The use of vertical flow constructed wetlands for on-site treatment of domestic wastewater: New Danish guidelines." University of Aarhus, Ole Worms Allé, Building 135, 8000 ° Aarhus C., Denmark. July 11th 2005. Copyright Elsevier B.V. 2005. Accessed 2/1/2010. Available at Sciencedirect.com.

*This article outlines new guidelines established in Denmark for the construction of VF wetlands and presents the performance of a sample of single family households VF wetlands results.*

3. Cameron et al. "Pollutant removal from municipal sewage lagoon effluents with a free-surface wetland." Environment Canada, McGill University, and University of Guelph. January 1st 2003. Copyright Elsevier Science Ltd 2003. Available at Sciencedirect.com.

*This is a case study of a constructed wetland consisting of a free-surface wetland, phosphorus adsorption slag filters and a vegetated filter strip.*

4. Cardoch et al. "An economic analysis of using wetlands for treatment of shrimp processing wastewater — a case study in Dulac, LA." Louisiana State University and University of Pennsylvania. September 14<sup>th</sup> 1999. Copyright Elsevier Science B.V 2000. Accessed 2/2/2010. Available at Sciencedirect.com

*This is a study of the economic feasibility of using a SF wetland for the treatment of wastewater in Dulac, LA.*

5. "Construction of a large flow AQUA Wetland System at a mushroom farm in Ontario, Canada." AQUA Treatment Technologies Inc, 104-155 Main Street East, Suite # 227, Grimsby, ON L3M 1P2. 2008. Accessed 1/25/2009. <http://www.aqua-tt.com/projects/mushroom.pdf>

*This is a slideshow of the construction of a surface flow Constructed wetland that was built in Ontario for a mushroom farm. It is useful because it shows process that is used to create these systems.*

6. Ghermandi et al. "The role of free water surface constructed wetlands as polishing step in municipal wastewater reclamation and reuse." School for Advanced Studies in Venice Foundation and Aquafin NV Dijkstraat. February 7th 2007. Copyright Elsevier B.V. 2007. Accessed 1/29/2010. Accessible at Sciencedirect.com.

*This report summarizes the results from multiple case studies performed on SF wetlands and summarizes their results.*

7. Greenway, Margaret. "The role of constructed wetlands in secondary effluent treatment and water reuse in subtropical and arid Australia." Science Direct and Griffith



University, Nathan, Qld 4111, Australia. Copyright Elsevier B.V. 2005. July 11<sup>th</sup> 2005. Available at Sciencedirect.com.

*This is an article on the use constructed wetlands can play in Australia to treat wastewater.*

8. Hadad et al. "Macrophyte growth in a pilot-scale constructed wetland for industrial wastewater treatment." Universidad Nacional del Litoral and Consejo Nacional de Investigaciones Científicas y Técnicas. November 9 2005. Copyright Elsevier Ltd 2005. accessed 1/29/2010. Available at Sciencedirect.com

*This is a case study of a constructed surface flow wetland that was used to treat wastewater in Santo Tome´, Santa Fe, Argentina.*

9. Li, William and Holmes, Geoffrey. "A New Life For the Old Tires." Stantec Consulting Ltd and Fisherman Bay Sewer District. 2/9/2010.

*This is a case study of a Stantec project which consisted of installing a SSF wetland to help a town better treat its wastewater.*

10. Manios et al. "Construction Simplicity and Cost as Selection Criteria Between Two Types of Constructed Wetlands Treating Highway Runoff." Technological Educational Institute of Crete and University of Kentucky. February 19 2009. Copyright Springer Science+Business Media 2009. Accessed 2/2/2010.

<http://www.springerlink.com/content/85874n373w671410/fulltext.pdf>

*This is a report comparing the effectiveness and economic feasibility of SF and SSF wetlands in treating highway runoff in Crete.*

11. Neralla et al. "Improvement of domestic wastewater quality by subsurface flow constructed wetlands." Texas A&M University, College Station, TX 77843-2474, USA. February 20th 2000. Copyright Elsevier Science Ltd 2000. Accessed 2/1/2010. Available at Scencedirect.com

*This 1999 study in Texas tracked the water quality of effluent from 8 subsurface wetlands for 2 to 4 years each.*

12. Puigagut et al. "Subsurface-flow constructed wetlands in Spain for the sanitation of small communities: A comparative study." Technical University of Catalonia, Campus Universitario, Centro de Nuevas Tecnologías del Agua, and University of León. April 7th 2007. Copyright Elsevier B.V. 2007. Accessed 2/1/2010. Available at Scencedirect.com.

*This is a report on the status of constructed wetlands in Spain.*

13. Rousseau et al. "Constructed wetlands for water reclamation." UNESCO-IHE Institute for Water Education, Ghent University, and Université Laval. September 6th 2001. Copyright Elsevier B.V. 2008. Accessed 2/1/2010. Available at Scencedirect.com.

*This paper gives an overview of treatment performances, reuse possibilities, operation and maintenance requirements, costs and constraints interfering with the application constructed wetlands.*

14. Song et al. "Seasonal and annual performance of a full-scale constructed wetland system for sewage treatment in China." Qingdao Technological University and

Shandong Normal University. October 25th 2005. Copyright Elsevier B.V. 2005.  
Accessed 2/1/2010. Available at Sciencedirect.com.

*A study conducted from 1999-2004 in Rongcheng, Shandong Province, China found that a subsurface flow wetland reduced SS by 78%, BOD by 70%, COD by 62%, total coliform by 99.7%, fecal coliform by 99.6%, ammonia nitrogen by 40%, and total phosphorus by 30%.*

15. Vymaza, Jan. "Horizontal sub-surface flow and hybrid constructed wetlands systems for wastewater treatment." Science Direct and Duke University Wetland Center, Nicholas School of the Environment and Earth Sciences, Durham, NC 27708, USA. July 11<sup>th</sup> 2005. Copyright 2005 Elsevier B.V. Accessed 1/25/2010. Available at Sciencedirect.com.

*This is a report on the effect constructed wetlands have on the quality of water they treat. It focuses on wetlands constructed in Europe and the history of their development.*

16. Yang et al. "Ecosystem service value assessment for constructed wetlands: A case study in Hangzhou, China." Zhejiang University, Zhejiang Gongshang University, and Université du Québec à Montréal. March 14<sup>th</sup> 2008. Copyright Elsevier B.V 2008. Accessed 1/29/2010. Can be found at Sciencedirect.com.

*This is a case study of a constructed wetland that was implemented at the Hangzhou Botanical Garden in China to treat water for an ornamental fish pond.*

17. Yocum, Dayna. "Design Manual: Greywater Biofiltration Constructed Wetland System." University of California, Santa Barbara. 2007.  
[http://fiesta.bren.ucsb.edu/~chiapas2/Water%20Management\\_files/Greywater%20Wetlands-1.pdf](http://fiesta.bren.ucsb.edu/~chiapas2/Water%20Management_files/Greywater%20Wetlands-1.pdf)

*Report on the uses, design, and construction of a Greywater Biofiltration system that is used to clean grey water.*

18. Zhang et al. "Constructed wetlands in China." Nanyang Technological University and San Diego State University. July 20 2009. Copyright Elsevier B.V.2009. Accessed 2/2/2010. Available as Sciencedirect.com.

*This is a study on the state of constructed wetlands in China is provides water quality, cost, environmental effects, and limitations of constructed wetlands.*

19. Zhou et al. "Energy evaluations for constructed wetland and conventional wastewater treatments." Peking University and Beijing Normal University. September 14th 2007. Copyright Elsevier B.V 2007. Accessed 2/2/2010. Available at Sciencedirect.com.

*This is a study on the economic feasibility of three different types of wastewater treatment systems in China. A SSF wetland, cyclic activated sludge system, and an activated sludge treatment were considered.*

## Xeriscaping

Xeriscaping became popular in the 1980s as a new theory for landscaping and farming during droughts. The term xeriscaping officially means “dry landscaping”, originating from Greek “xeros” which means “dry” (Iannotti, “Xeriscape Gardening” 2008). The overall purpose of xeriscaping is to produce fruitful vegetation and beautiful landscaping with the minimal amount of water consumption (Beaulieu, “Xeriscaping Plants” 2009). If water usage continues at its current rate, by 2030 the estimated global water demand will be 40% greater than the current supply available (Water Resources Group, 2008). Since the main focus xeriscaping is to reduce water usage, it should be implemented in place of traditional landscaping, in order to help reduce the strain on the water supply.



**Figure 31: Xeriscaping Example (Fuller, 2010)**

- Xeriscaping cost ranges from approximately US \$1.50 - \$9 per square foot.
- Conserves potable water by reducing usage
- Low impact and flexible to fit a variety of needs
- Xeriscaped areas are very low-maintenance.
- Depending on the intricacy and overall goal, gardens can have large capital costs.

## ***Technical Description***

Xeriscaping has seven chief principles that contribute to the overall goal: planning and design, soil improvement, minimizing turf, appropriate plant selection, efficient irrigation, use of mulch, and maintenance. Important aspects of xeriscaping are grouping plants with similar needs together and minimizing the amount of lawn. Although large manicured lawns are popular, they require a great amount of water, and xeriscaping encourages reduction of lawn areas and switching to low maintenance alternative covering. Proper planning and plant selection are also vital to reduce the amount of maintenance and water required to sustain the landscaping (Smith, 2010). In order to ensure maximum growth, suitable nutrients in the soil must be provided for the plants via mulching and irrigation. Applying these techniques encourages water conservation and improved water quality while maintaining a beautiful garden (Iannotti, "Xeriscaping Gardens" 2010).

The best type of vegetation to use when building a xeriscaped garden are plants that are drought tolerant (Smith, 2010). Plants that are appropriate for desert regions are typically hardy, low care, and drought resistant. These particular plants are also inexpensive, easy to locate, and provide attractive colors. Some examples of these types of plants are Bougainvillea, Oleander, Texas/Purple Sage, Lantana, Pampas Grass, Fairy Duster, Red Bird of Paradise, Orange Jubilee, and Yellow Bells. These plants can thrive in dry sunny regions like Phoenix, Arizona (Hedding, 2010).

## **Planning & Design**

Adequate planning is an imperative step to designing an efficient and effective xeriscaped area because the plants and water must work in synch with natural surrounding landscape. Plants with similar water needs should be placed in beds

together to allow for optimum growth with minimal water waste. Even though plants that require minimal amounts of water are preferred native plants that require more water can be used. The drought-tolerant plants should be positioned on the side of the prevailing winds so they can shelter the less tolerant plants (Williams, 2007).

Proper grading of the land also needs to be planned for, in order for the water to soak into the soil and be absorbed by plants rather than becoming runoff. Slopes can be changed or terraced to assist this process. Typically raised beds dry out much quicker than standard flat beds and are not encouraged (Williams, 2007).

Some environmental considerations that must be taken into account when planning xeriscaped sites are the directional winds and the sunny and shaded areas that may change throughout the day or season. Utilities and obstructions that are underground may be problematic when grading or digging (Landscape America, 2010).

## **Soil Improvement**

Soil composition and quality is directly related to the health and fertility of the plants growing in that soil. In order to determine what type of soil is present, it must be tested by collecting a sample. This sample can be analyzed in a lab or with a soil sample kit. Both can determine composition, nutrients, and other characteristics. However, the laboratory results are more accurate (Percolation Test, 2010).

Most types of soil can be altered to grow various kinds of vegetation. The typical extremes of soil are sand and clay. Sand drains quickly after rain while clay creates a barrier to rain infiltrating the subsurface. The majority of soils fall in between these two categories. Sand can be worked with easily but needs a lot of vegetative covering to shelter it from wind and water erosion. Due to its low moisture and nutrient-holding capacity, sand needs frequent watering and fertilization. Clay, on the other hand, is made up of small particles and can hold so much water that the plants suffer from lack of oxygen (Williams, 2007). Both types of soil can be improved with generous portions of organic matter such as compost, well-rotted manure, or peat moss. To do this, a layer

of organic matter approximately 7.6-10 cm (3-4 in) thick should be spread on the ground and then thoroughly mixed with the existing soil (Williams, 2007).

## Minimizing Turf

Since lawns require water, fertilizer, and gasoline (for typical lawnmowers) in order to keep them looking healthy, xeriscaping focuses on reducing the amount of lawn turf. There are two main ways of accomplishing this; simply minimizing the actual area covered with grass or using alternative lawn coverings in place of grass. No matter what method is used, grass that is suitable for the area should be chosen because different grasses thrive in different locations.

Moss and clover are becoming popular alternatives to the traditional grass lawn (Beaulieu, "Top 10 Tips" 2008). Moss is low growing and low maintenance because it derives nutrients and water from the surrounding air. Its ideal conditions are shady, moist areas (Beaulieu, "Moss Plants" 2009). Clover is also naturally low maintenance and has the qualities looked for in a lawn. It doesn't discolor, doesn't need to be fertilized, and doesn't grow weeds (Beaulieu, "Irish Shamrocks" 2008).



**Figure 32: Alternative Ground Cover (Cariboo Chilcotin Conservation Society, 2004)**

## Appropriate Plant Selection



Proper plant selection is significant for xeriscaping in order to conserve water and to ensure thriving vegetation. Choosing plants that require little water and are native to the specific region is preferred. Typically, both types of plants help to ensure optimum growth (Landscape Design Advisor, 2007).

## **Efficient Irrigation**

Since all plants do not need the same amount of water to survive, the prior steps (planning & design, soil improvement, minimizing turf, and appropriate plant selection) help group the plants according to the quantity of water required (Landscape Design Advisor, 2007). By arranging the plants in accordance with those processes the least amount of water will be wasted from over watering and runoff. Typically, drip irrigation systems are the most efficient watering arrangements because it allows for the most control. Drip irrigation provides control over the amount and the time the plants receive water (Northern Garden Supply, 2007). This type of system is ideal because all plants require slightly more water the first few years before they have become established. After the plant matures, it needs slightly less water (Iannotti, "Xeriscape Gardening" 2008).

Drip irrigation is a water conserving alternative to lawn sprinklers and has been called "subsurface drip irrigation". It runs at a low pressure to gradually and precisely deliver water to the plant's roots using plastic tubing (Shock, 2006). Not only does drip irrigation reduce the amount of water emitted from the irrigation system, but it reduces the amount of water wasted by runoff, evaporation, and overspray. Drip irrigation originated in areas without a large supply of water and has become popular in all types of climates to reduce the cost of irrigation (Northern Garden Supply, 2007).

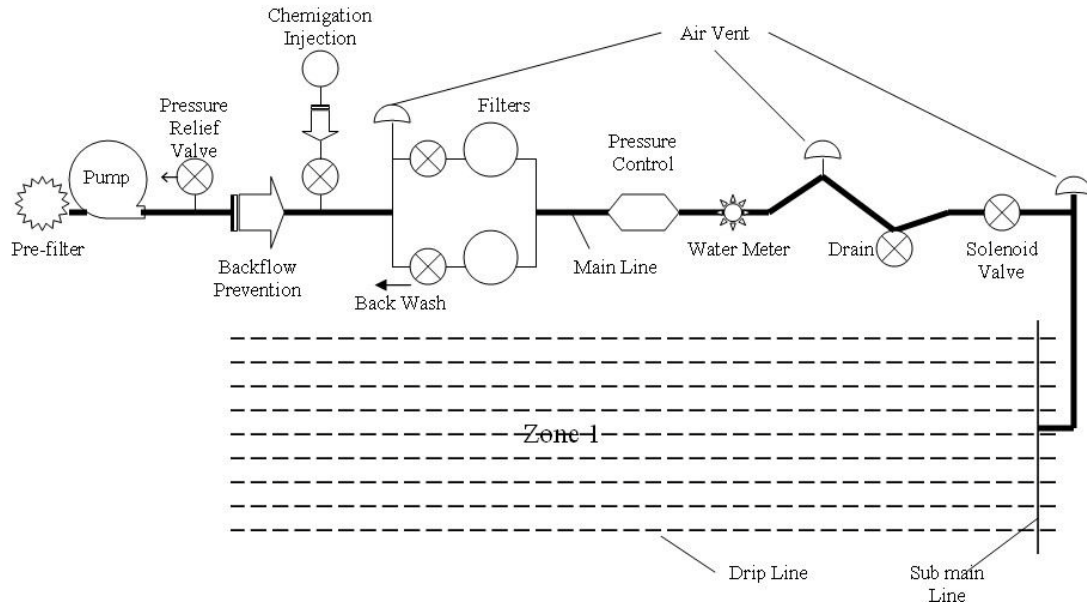

**Figure 33: Diagram for a standard drip irrigation system (Shock, 2006)**

## Use of Mulch

Mulch can be anything from store-bought shredded bark and compost to naturally occurring leaves and debris (Landscape Design Advisor, 2007). The purpose of mulch is to moderate soil temperature, capture moisture, reduce erosion, and lessen the amount of weeds that could detract from the plants' food and water supply (Beaulieu, "Top 10 Tips" 2008). Since the mulch gradually decomposes, nutrients are slowly added to the soil over time. Typically 2 to 4 inches of mulch are required when first planted and more may be needed as time passes (Iannotti, "Winter Mulching" 2008).

In the summer mulch acts as an insulator that decreases the need for water and shields the roots from severe heat. The mulch from the winter typically needs to be replaced in the spring. This allows the plants room to sprout while helping the soil to be warmed and fed. Conditioning compost or manure should be put down in the fall, along with mulch, to guard the plants from winter weather. In the winter, mulch is used to ensure a consistent ground temperature. A steadily frozen ground keeps the plant

dormant and thwarts early growth while keeping water inside the garden bed (Beaulieu, "Garden Mulch" 2009).

## **Maintenance**

Xeriscaped gardens require weeding, pruning, deadheading, and natural pest management (Iannotti, "Xeriscape Gardening" 2008). Weeding is simply removing an undesired plant from the garden bed because it consumes water, nutrients, and sunlight needed for the desired plants. Pruning involves cutting back parts of a plant in order to allow more room for the growth of that plant and others around it. Deadheading refers to removing the dead parts of plants via cutting or plucking to permit more development throughout the summer and fall. Natural pest management is important because some pests cause harm to plants by eating them or the nutrients they need to survive. By using the correctly selected insects and plants, harmful bugs should not be a problem.

## ***Potential Benefits***

- Time and money are saved by having less grass to mow (American Lawns, 2010).
- Conserves potable water by reducing usage
  - Reduces water consumption by up to 50% because water is dispersed directly to the roots (Northern Garden Supply, 2007)
- Healthy for the local environment
  - Reduces the use of fertilizers and pesticides that could contaminate local water supplies (American Lawns, 2010)
  - Can help reduce water runoff and soil erosion (Shock.,2006)
  - Increased vegetation contributes to reduction of carbon dioxide by using photosynthesis (Sustainable Sites Initiative, 2008).

- Clover as an alternative lawn covering is drought tolerant, weed resistant, doesn't need fertilizer, soft, requires little mowing, doesn't discolor, and is relatively pest free (Beaulieu, "Irish Shamrocks" 2008).
- Aids in plant life development
  - Controls the amount of weeds because the water is delivered to the plants deep down in the soil and most weeds have shallower roots (Northern Garden Supply, 2007)
  - Healthier plants result because of the slow constant feed of water which keeps the roots moist (Northern Garden Supply, 2007).
  - Nutrients can be emitted through the drip irrigation system (Shock, 2006).
- Low impact and flexible to fit a variety of needs
  - Drip irrigation is low profile and very quiet (Northern Garden Supply, 2007).
  - Fits uneven and abnormally shaped gardens and fields (Shock, 2006).
  - Drip irrigation doesn't compact the soil like high-pressured sprinklers (Northern Garden Supply, 2007).
  - Timers can be installed on drip irrigation systems to water on a schedule, if desired (Northern Garden Supply, 2007).
  - Drip systems can be buried for a longer service life or left on top of the ground for easy servicing (Northern Garden Supply, 2007).
  - Reduce watering needs by selecting the appropriate type of grass for the local environment (American Lawns, 2010)
- Increases home value & curb appeal by heightening the impact of the reduced lawn with surrounding gardens (American Lawns, 2010)
- Xeriscaped areas are very low-maintenance (Beaulieu, 2008).

## ***Potential Risks and Considerations***

- Proper maintenance of a drip irrigation system is important because the plastic tubing can leak or become plugged (Shock, 2006).
- Cultivation and weeding practices need to be taken into consideration when deciding the tube depth (Shock, 2006).
- Depending on the intricacy and overall goal, gardens can have large capital costs (Shock, 2006).

## ***Estimated Cost***

Xeriscaping cost ranges from approximately US \$1.50 - \$9 per square foot. Xeriscaping saves about US \$0.36 per square foot annually when compared with a traditional garden (which includes fertilizer, water, lawnmower, and maintenance. It can cost between US \$1.50 to US \$2.50. The average payback occurs within 4 to 7 years (Klimchuk, 2008).

In Portland, Oregon a residential sustainable garden was built for only US \$3.50 per square foot including design, materials, and labor (Sustainable Sites Initiative, 2008).

A residential garden developed using sustainable practice is approximately US \$9 per square foot based on a project in Santa Monica, California. It was only US \$2 per square foot more than an equivalent non-xeriscaped garden in the same region (Sustainable Sites Initiative, 2008).

## **Water**

A typical 1,000 square foot lawn needs 132,500 liters of water per year, but an equivalent space with drought tolerant plants only uses 56,780 liters. One study found that a lawn with Kentucky Bluegrass, trees, and shrubs used 79 liters per square foot, and a xeriscaped version of that area only needed 13 liters per square foot. Depending on the cost of water in the region, xeriscaping can save from 55% to 85% on water expenses. (Klimchuk, 2008)

For drip irrigation, the approximate cost per acre is US\$500 to \$1,200. Part is capital cost that applies for a few years, but the other part is annual (Shock, 2006).

## **Maintenance**

Sustainable gardens cost almost 70% less man hours a year to maintain compared to a traditional garden (Sustainable Sites Initiative, 2008).

## ***Recommended Site Characteristics***

Since there are so many options in xeriscaping, some lists are provided below giving possible options for xeriscaping in different climates or for xeriscaping with a different desired final product.

## **Minimizing Turf**

*Best Cool Season Grass*

- Bentgrass
- Kentucky Bluegrass
- Rough Bluegrass
- Red Fescue
- Annual Ryegrass



Figure 34: Cool Season Grass (American Lawns, 2010)

*Best Transition Zone Grass*

- Kentucky Bluegrass
- Tall Fescue
- Perennial Ryegrass
- Thermal Blue
- Zoysiagrass



Figure 35: Transition Zone (American Lawns, 2010)

### *Best Warm Season Grass*

- Bahia
- Bermudagrass
- Buffalograss
- Carpetgrass
- Centipede



**Figure 36: Warm Season Grass (American Lawns, 2010)**

### *Alternative Ground Covers*

- Barrenwort is a perennial covering that blooms in spring and thrives in partially shaded areas.
- Bishop's weed can be plain green or multicolored, and it spreads easily in the sun or shade.
- Cotoneaster is typically a hardy, low growing, small leaf shrub that can handle dry slopes.
- Heath and Heather are low-growing plants that have tiny flower spikes in spring (Heath) or fall (Heather) and can occupy shaded or sunny areas.



- Bugleweed has green, purple-tinted, or variegated leaves that produce white flowers in the spring.
- Cinnamon fern grows best in shady areas and spreads slowly.
- Hosta is a foliage plant with fragile flower spikes during the mid to late summer. It does well in shaded environments and some variegated varieties do well in moderate sunlight.
- Irish moss forms a very low cover with a taut mat of petite, shaggy green leaves and grows best in moist shade areas.
- Ivy is a classic groundcover with tough triangular evergreen leaves and grows in both sun and shade.
- Wild ginger formulates neat low patches of patterned leaves while spreading slowly in shady regions.
- Lungwort grows best in moist soil with partial shade, and it comes in a variety of colors and shapes.
- Maidenhair fern spreads slowly and can reach up to 2 feet tall in shady, cool, moist soil.
- Lady's mantle grows best with sun or partial shade and has distinguishing ray-green scalloped leaves.
- Lily-of-the-valley spreads consistently in shady areas, but its leaves die by late summer.
- Pachysandra is a classic groundcover, which matures to 3" - 4" with a little flower spike in the early spring and remains green all winter. It spreads uniformly and likes partial sun to shade.
- Periwinkle grows low with tiny, oval, glossy green leaves all year round.
- Snow-in-summer is easy to grow and grows in sunny sites with poor soil.
- Sweet woodruff weaves a net of fine roots while the leaves hold a delicate, white spring flower.
- Thyme is a low-growing woody, evergreen plant with petite lavender-pink flowers which bloom in the late spring.
- Spotted dead nettle has crinkled variegated leaves on 6" stems. It likes shade and has minuscule lavender flowers (if left untrimmed).

- Variegated lily turf forms neat bundles about 8" - 12" tall and grows in both sun and shade.

(American Lawns, 2010)

Appropriate Plant Selection

*Drought Tolerant Flowers*

- Achillea (Yarrow)
- Alyssum
- Asclepias (Butterfly Weed)
- Beebalm
- Bougainvillea
- California Poppy
- Campis (Trumpet vine)
- Cosmos
- Cranesbill Geranium
- Daylily
- Euphorbia
- Fairy Duster
- Gaillardia
- Goldenrod
- Greek oregano
- Heliopsis
- Iris
- Kniphofia (Red Hot Poker)
- Lamb's Ears
- Lavender
- Oleander

- Orange Jubilee
- Penstemon
- Perovskia (Russian Sage)
- Portulaca
- Rudbeckia
- Tradescantia (Spiderwort)
- Veronica
- Yellow Bells
- Zinnia

*Drought Tolerant Grasses*

- Feather Reed Grass Fescue
- Fountain Grass (Pennisetum)
- Maiden Grass (Miscanthus)
- Switch Grass (Panicum)

*Drought Tolerant Shrubs*

- Amelanchier (Shadbush)
- Aronia (Chokeberry)
- Buddleia (Butterfly Bush)
- Hypericum (St. Johnswort)
- Juniper
- Potentilla
- Viburnum

(Hedding. 2010 & Iannotti, "Xeriscaping Gardens" 2008)

## Use of Mulch

### *Pine Straw Mulch*

- Appearance: Pine straw mulch provides the reddish-brown color (although less vivid) that redwood bark mulch offers.
- Insulating value in summer: Good
- Insulating value in winter: Good
- Need to remove in spring: Yes
- Nourishment & aeration afforded to underlying soil by decomposition: Fair
- Lets water and oxygen move freely into the soil: Excellent
- Ease of application and maintenance: Good

### *Wood Chips, Sawdust and Bark Mulches*

- Appearance: Good
- Insulating value in summer: Good
- Insulating value in winter: Good
- Need to remove in spring: Yes
- Nourishment & aeration afforded to underlying soil by decomposition: Fair
- Lets water and oxygen move freely into soil: Good
- Ease of application and maintenance: Good

### *Black Plastic Mulch*

- Appearance: Poor, unless you desire the "hi-tech" façade.
- Insulating value in summer: Good and bad. Black plastic mulch keeps the moisture in the soil from escaping, but heats up the ground considerably.
- Insulating value in winter: Fair
- Need to remove in spring: No
- Nourishment & aeration afforded to underlying soil by decomposition: None
- Lets water and oxygen move freely into soil: No
- Ease of application and maintenance: Excellent

### *Stone Mulch*

- Appearance: Good. Best if used around trees, cacti and succulents; but it may not be aesthetically appropriate for vegetable or flower gardens.
- Insulating value in summer: Fair. Stone mulch tends to heat up, but it also retains much of that heat within itself.
- Insulating value in winter: Fair. Even though stone mulch grows cold easily, it keeps that much cold off your soil.
- Need to remove in spring: Yes
- Nourishment & aeration afforded to underlying soil by decomposition: None
- Lets water and oxygen move freely into soil: Yes
- Ease of application and maintenance: Good

### *Mulching With Partially Composted Leaves*

- Appearance: Fair
- Insulating value in summer: Excellent
- Insulating value in winter: Excellent
- Need to remove in spring: Yes
- Nourishment & aeration afforded to underlying soil by decomposition: Excellent
- Allows water and oxygen move freely into soil: Fair (unless leaves are very finely shredded).
- Ease of application and maintenance: Fair

### *Straw and Hay Mulches*

- Appearance: Straw brightens your area nicely. Hay is less eye-catching, but provides a softer look and texture.
- Insulating value in summer: Excellent
- Insulating value in winter: Excellent
- Need to remove in spring: Yes
- Nourishment & aeration afforded to underlying soil by decomposition: Excellent
- Lets water and oxygen move freely into soil: Excellent
- Ease of application and maintenance: Fair

- *Note:* Straw is generally preferred over hay because hay tends to be riddled with weed seeds.
- *Note:* Straw is one of the best mulch choices for winter protection, due to its insulation potential. Since its hollow, each strand of straw supplies dead air space, which may be the best characteristic of an effective insulator.

(Beaulieu, 2010)

## Maintenance

### *Organic Pest Management - Helpful Insects*

<u>Problem Insect</u>	<u>Helpful Insect</u>
• Aphids	Ladybugs, Praying Mantis & Lacewing
• Caterpillars	Wasps & Spined Soldier Bug
• Spider Mite	Galandromus Occidentalis & Amblyseius Fallacies
• Thrips	Amblyseius Cucumeris & Orus Insidious
• Whitefly	Delphastus Catalinae & Encarsia Formosa

(Natural Insect Control, 2009)

### *Organic Pest Management - Helpful Plants*

<u>Problem Insect</u>	<u>Helpful Plant</u>
• Ants	Mint, Pansy & Pennyroyal
• Aphids	Mint, Garlic, Chives, Coriander & Anise
• Bean Leaf Beetle	Potato, Onion & Turnip
• Codling Moth	Common Oleander
• Colorado Potato Bug	Green Beans, Coriander & Nasturtium
• Cucumber Beetle	Radish & Pansy
• Flea Beetle	Garlic, Onion & Mint

- Cabbage Worm                      Mint, Sage, Rosemary & Hussop
- Japanese Beetle                 Garlic, Larkspur, Tansy, Rue & Geranium
- Leaf Hopper                        Geranium & Petunia
- Mice                                 Onion
- Slugs                                Prostrate Rosemary & Wormwood
- Spider Mites                      Onion, Garlic, Cloves & Chives
- Squash Bug                        Radish & Marigolds
- Stink Bug                         Radish
- Thrips                              Marigolds
- Whitefly                          Marigolds & Nasturtium

(Michaels, 2005)

## ***Potential LEED Credits***

- Water Efficiency Credit 1: Water Efficient Landscaping (2 to 4 points) To limit or eliminate the use of potable water or other natural surface or subsurface water resources available on or near the project site for landscape irrigation.
- Water Efficiency Credit 2: Water Use Reduction (2 to 4 points) To further increase water efficiency within buildings to reduce the burden on municipal water supply and wastewater systems.

## ***Relevant Stantec Projects***

### **1. Las Vegas Executive Air Terminal at McCarran International Airport**

Location: Las Vegas, Nevada, US

Description: Stantec provided landscape architecture for the airport and heavily focused on the principles of xeriscaping with desert trees and shrubs, drip irrigation, minimal turf, and alternative ground covers.

Link: [http://marketingexcellence/projectprofile\\_preview.aspx?id=10&project=4849](http://marketingexcellence/projectprofile_preview.aspx?id=10&project=4849)

### **2. University of Alberta, the Edmonton Clinic North**

Location: Edmonton, Alberta, CA

Description: Stantec provided architectural services for the university targeting LEED Silver. Xeriscaping was used to reduce stormwater runoff along with other sustainable alternatives.

Link: [http://marketingexcellence/projectprofile\\_preview.aspx?id=10&project=14483](http://marketingexcellence/projectprofile_preview.aspx?id=10&project=14483)

### **3. Bingham Junction**

Location: Midvale, Utah, US

Description: A 221 acre Superfund Site required Engineering, landscaping, and irrigation construction from Stantec. The first phase required xeriscape work over the entire site with low-maintenance plants and drip irrigation.

Link: [http://marketingexcellence/projectprofile\\_preview.aspx?id=10&project=14804](http://marketingexcellence/projectprofile_preview.aspx?id=10&project=14804)

### **4. ADOT Statewide Rest Area Rehabilitation**

Location: Statewide, Arizona, US

Description: One of Stantec's many contributions to this project was landscape architecture, where xeriscaping was the focus. Native plants and low water use irrigation were both highlights of the project.

Link: [http://marketingexcellence/projectprofile\\_preview.aspx?id=10&project=11712](http://marketingexcellence/projectprofile_preview.aspx?id=10&project=11712)

### **5. South Ogden Auto Plaza**

Location: South Ogden, Utah, US

Description: In order to conserve water, Stantec utilized xeriscape planting with an irrigation drip system and a planting and rock mulch area.

Link: [http://marketingexcellence/projectprofile\\_preview.aspx?id=10&project=14793](http://marketingexcellence/projectprofile_preview.aspx?id=10&project=14793)



## Sources

1. American Lawns. "Types of Grasses found in America" 2010. Accessed Feb. 1 2010. <http://www.american-lawns.com/grasses/grasses.html>

*This site gives information about species of grass and appropriate climates.*

2. Beaulieu, David. "Garden Mulch 101 – Selecting the Proper Garden Mulch" 2009. Accessed Jan. 21 2010. <http://landscaping.about.com/cs/compostandmulch/a/mulches.htm>

*Techniques about proper mulching are discussed at this site.*

3. Beaulieu, David. "Irish Shamrocks and 4-Leaf Clovers" 2008. Accessed Jan. 20 2010. [http://landscaping.about.com/cs/lawns/a/clover\\_lawns.htm](http://landscaping.about.com/cs/lawns/a/clover_lawns.htm)

*Here, popular alternative ground covers are mentioned.*

4. Beaulieu, David. "Moss Plants: Shad Garden Favorite an Alternative to Lawns" 2009. Accessed Jan. 20 2010. <http://landscaping.about.com/cs/groundcovervines1/p/moss.htm>

*Another favorite alternative lawn cover, moss, is discussed here.*

5. Beaulieu, David. "Top 10 Tips for Low-Maintenance Landscaping" 2008. Accessed Jan. 19, 2010.

[http://landscaping.about.com/od/lazylandscaping/tp/low\\_maintenance.htm](http://landscaping.about.com/od/lazylandscaping/tp/low_maintenance.htm)

*This site talks about how xeriscaping and other techniques for landscaping can be very low maintenance.*

6. Beaulieu, David. "Xeriscaping Plants: Drought-Resistant Plants" 2009. Accessed Jan. 29 2010.

<http://landscaping.about.com/cs/cheaplandscaping1/a/xeriscaping.htm>

*Information about proper plants for xeriscaping is presented here.*

7. Cariboo Chilcotin Conservation Society. "Water Wise" 2004. Accessed Feb. 23, 2010. <http://www.cconserv.org/water-wise.html>

*Photo Source.*

8. Evergreen. "Native Plant Database" Copyright 2000-2010. Accessed Jan. 20 2010. <http://nativeplants.evergreen.ca/search/guided.php>

*This site has an interactive database with information about native plants.*

9. Fuller, John. "How Xeriscaping Works" Copyright 1998 – 2010. Accessed Feb. 23 2010. <http://home.howstuffworks.com/lawn-garden/professional-landscaping/alternative-methods/xeriscaping.htm>

*Photo Source.*

10. Hedding, Judy. "Desert Plants" 2010. Accessed Jan. 19 2010.

<http://phoenix.about.com/od/desertplantsandflowers/a/desertplants.htm>

*More various facts about native plants are provided here.*

11. Iannotti, Marie. "Winter Mulching in Cold Climate Gardens" 2008. Accessed Jan. 21 2010. [http://gardening.about.com/od/winterinthegarden/a/WInter\\_Mulch.htm](http://gardening.about.com/od/winterinthegarden/a/WInter_Mulch.htm)

*Additional information about mulching techniques is given at this site.*

12. Iannotti, Marie. "Xeriscape Gardening – Planning for a Water Wise Garden" 2008. Accessed Jan. 19 2010.  
<http://gardening.about.com/od/gardendesign/a/Xeriscaping.htm>

*This link discusses how xericaping helps conserve water.*

13. Klimchuk, Amanda. "Xeriscaping: Procedure, Analysis, and Recommendation" 2008. Accessed Feb. 9 2010.  
[http://www.thelivinghome.ca/index.php?option=com\\_content&task=view&id=117&Itemid=159](http://www.thelivinghome.ca/index.php?option=com_content&task=view&id=117&Itemid=159)

*Further details about xeriscaping practices are discussed.*

14. Landscape America. "Site Analysis" 2010. Accessed Feb. 1 2010.  
<http://www.landscape-america.com/landscapes/design/site.html>

*Details about how to prepare a site for xeriscaping are discussed.*

15. Landscape Design Advisor. "Natural Outdoor Living with Xeriscape Landscape Design" 2007. Accessed Jan. 20 2010.

<http://www.landscape-design-advisor.com/xeriscape-landscape-design.html>

*The seven xeriscaping topics are the main focus of this site.*

16. Michaels, Patricia A. "An Introduction to Organic Pest Management" 2005. Accessed Jan. 21 2010. <http://greennature.com/article307.html>

*This link gives information about how to thwart off insects naturally.*

17. Natural Insect Control. "Beneficial Insects" 2009. Accessed Jan. 22 2010. <http://www.natural-insect-control.com/cat.php?cat=5>

*Additional information about organic pest management is given here.*

18. Northern Garden Supply. "Drip Irrigation" 2007. Accessed Feb. 1 2010. <http://www.dripirrigation.ca/>

*This site provides facts about how drip irrigation functions.*

19. Percolation Test. "Soil Test" Accessed Feb. 5 2010. <http://www.percolationtest.com/soil-test.php>

*Data is given about the proper way to test soils before planting.*

20. Shock, C.C. "Drip Irrigation: An Introduction" 2006. Accessed Feb. 1 2010.  
<http://www.cropinfo.net/drip.htm>

*Some basic information about drip irrigation systems is provided here.*

21. Smith, S.E. "What is Xeriscaping" Copyright 2010. Accessed Jan. 19 2010.  
<http://www.wisegeek.com/what-is-xeriscaping.htm>

*This site gives a general overview and background information on the topic.*

22. Sustainable Sites Initiative. "Why Sustainable Sites?" 2008. Accessed Jan. 21 2010. Available at <http://www.sustainablesites.org/why/>

*Case studies about xeriscaping are given on this site.*

23. Water Resources Group. "Water Scarcity Report" 2008. Accessed Feb. 22 2010.  
<http://www.nestle.com/InvestorRelations/Events/AllEvents/2030+Water+Resources.htm>

*Information on the water issues currently and in the future.*

24. Williams, Sara. "Xeriscape Landscaping" 2007. Accessed Jan. 19 2010.  
<http://gardenline.usask.ca/yards/xeri1.html>

*This link provides background information and the basics of xeriscaping.*

## District Energy

District energy usually refers to district heating and cooling, which is a system that centralizes air conditioning and heating loads for multiple buildings in one facility. The concept of district heat is not new, as steam pipes have been installed in large cities since the mid 1800s, with the most famous one being the steam heat in New York City, which has been operating since 1882. District heating is prevalent in some areas of the world, and the applicability of such a system is usually based on the availability of cheap energy. The country with the highest market penetration of district heating is Iceland, in which over 90% of the country receives space heating and water heating from a district energy system. This is due to the wide availability of geothermal heating throughout the country. (Thorsteinsson, 2008) Iceland is an excellent example of a government recognizing the potential of its nation's renewable resources, and making use of them very effectively.

District energy is becoming increasingly popular because it can represent a significant monetary savings for the end user. These systems are popular mostly in urban areas, so areas which may be applicable for a district energy system are cities or dense towns which are trying to create incentives for businesses to operate there. Another possibility is that a renewable resource such as geothermal may have been discovered, and district heating or cooling may be a good way to utilize it. District cooling may be attractive especially in areas with very high cooling demands for most or all of the year, since cooling equipment can use up vast amounts of electricity. These systems are becoming more efficient all the time, so in the near future they may become more attractive to local governments. The largest untapped sector however, is the possibility of district energy supplying mainly residential areas. Right now the technology is not there to support such a plan economically, due to the losses in energy in transmission, and the high cost of hookups for individual homeowners or landlords. However if such a system is integrated into a new development, it may be possible to greatly reduce the energy bills of the owners without as large of a cost for hooking up to the new system. This represents a potential attraction for developers, and it may be to

Stantec's benefit to look into the feasibility of such a system on any large residential or business developments in the future. A good model to follow would be existing industrial parks which already utilize a similar system, just with fewer hookups and higher demand users.

### District Energy

- Cost:
  - extremely variable based on size of the system – see estimated costs section for case studies
- Benefits:
  - Potential Energy savings
  - Great applicability to renewable resources such as geothermal heat
  - Lower costs for the end user
- Risks
  - Expensive systems can require a great deal of capital to install and maintain
  - Use of fossil fuels or gas for a heat source can pollute

### ***Technical Description***

District heating and district cooling can be separate systems or combined, though both work essentially the same way. A large facility will cool down or heat up a large amount of water, depending on the heating or cooling needs of the district. This water is then pumped through insulated pipes (usually underground) to the surrounding buildings, which will extract heat from it in the cold weather or reject heat into it in warm weather. In order to function properly a district cooling facility may need a source of cool water for the equipment to operate, which can be created using refrigeration techniques or can be diverted from a body of water or groundwater source. Cooling systems can

also use a heat source to cool water through an absorption chilling process. District heating requires some source of heat, which can either be generated on site, or diverted from waste heat generated by other industrial processes.

## District Cooling

District cooling systems can use a wide variety of equipment and techniques to generate cool water, but there are three systems used most commonly in cooling facilities, sometimes in combination with each other.

Using a water source as a heat sink has proven to be one of the most efficient of the available means of cooling. (Chow, "Applying District Cooling", 2004) This process involves piping a circulating water system to exchange warm water in the system for cool water from the source. Usually deep lakes or oceans are used, although in some cases ground water sources are also tapped for this purpose. (Hawaii, 2002) This cool water is usually not piped to buildings, but rather it is used to reject heat from a cooling coil, which in turn is absorbing heat from the water which is circulating in the system. In this way, the circuit of the cooling water to buildings can be kept as a closed loop.

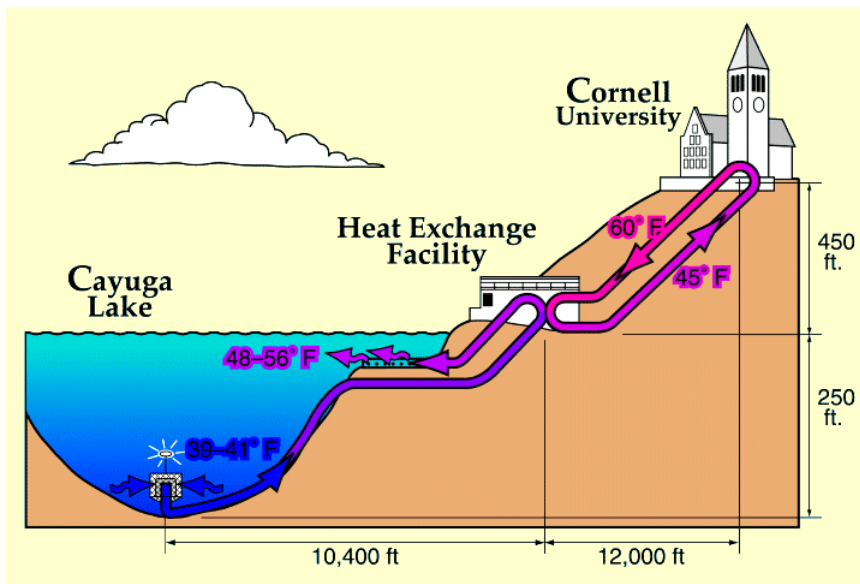

Figure 37 – Cornell University Lake Source Cooling System



The reason that this method is so efficient is that no constructed cooling or heating actually takes place. The only power needed is to run the pumps which circulate the closed system and pump water from the cooling source to the facility. (Zogg, 2008)

An efficient alternative if a body of water is not close by is to use absorption chillers, which function by using heat instead of electricity to chill the water. This technology functions by evaporating a refrigerant to remove heat from the surrounding air. The refrigerant is then absorbed by an absorbent medium. The medium is then heated, which releases the refrigerant from the absorbent medium. Next the refrigerant is condensed back to a liquid in a condenser, allowing it to cool. This allows the refrigerant to be pumped back into the evaporator, completing the cycle. (Mahone, 1998) Absorption chillers are ideal for situations where there is waste heat to be captured, or where heat may be cheaper or easier to get than electric power. (Mahone, 1998)

This allows these systems to make use of waste heat from other processes, making them ideal candidates for cogeneration. (Kanoglu, 1998) Cogeneration is where one source of heat is used to produce both electricity and to power other equipment, making these processes very efficient.

A less efficient method of district cooling is to use electricity to power chillers, most often either traditional compression refrigerant chillers or centrifugal compression chillers. On a larger scale, centrifugal compressors are often used because they are more efficient than a standard air compressor that might be found in commercial refrigeration technology. They also provide continuous flow of lower pressure compressed air much more efficiently than other types of compression technology. (McQuay, 2000) Although these systems are not as efficient as the previous two, they still represent a significant energy savings as compared to using individual air conditioning units for all of the buildings serviced. (Hanson, 2007) These systems are typically coupled with cooling tower technology, which is used to reject the heat gathered from the buildings into the air. Although these electrical systems use more energy overall than cogeneration or water source cooling, they can still be made very

efficient by a number of optimization methods. (Shimoda, 2005)(Wang, 2008)(Hanson, 2007) (Vitooraporn, 2001)

Lately much research has been conducted in the area of thermal storage. This technology applies to district heating as well, but is more commonly used in district cooling systems. The process involves using excess capacity in the cooling system to cool a thermal storage medium, often a large tank of salt water or ice, which can later be used to supplement the cooling power of the chillers. The main purpose of such a system is to help offset peak loads, so that the chillers run at a more even level throughout the day. Although this in some cases may reduce efficiency of the chillers (many systems run most efficiently at full load) the net benefit is that the power generators do not have to deal with spikes in power demand, which will greatly reduce the efficiency of power generation. (Chan, 2005) This means that thermal storage systems make sense usually when the district cooling systems use electricity from an outside power plant to run the chillers.

## **District Heating**

District heating functions on the same fundamental ideas as district cooling, except the system is distributing heat instead of collecting it. Like district cooling there are a number of different approaches that can be used to heat the water for distribution to the serviced buildings, including cogeneration with industrial waste heat, solid waste incineration, and coal power generation. Other common options are natural gas, solar thermal, geothermal, biofuel (including peat, wood, algae, and anaerobic digestion), as well as heating oil or kerosene. (Pöyry, 2009) Of these, the five most common systems are cogeneration with electricity from a power plant(most often coal), heat from waste incineration, industrial waste heat, geothermal, and normal heating fuels(natural gas or fuel oil). (Werner, 2004)

Cogeneration with electrical plants has gained popularity due to the high efficiency of the process. Since the energy utilized by the system would normally be

wasted and released into the atmosphere, it can result in a large energy savings compared to separate generation of electricity and heat. Coal is the most common type of power plant, with the steam used to power the turbines diverted after the electrical generation to heat water in a closed loop before it continues to the atmosphere. (Erdem, 2009) It was found in a case study of a coal fired plant that “17.94% of boiler energy is released by stack gases, 46.04% released by condenser and the remaining 36.02% is converted to mechanical power.” (Erdem, 2009). Depending on where in the generation process the heat is extracted, large amounts of heating power can be removed from the process with minimal impact on electrical generation. Similarly, cogeneration with geothermal power can result in high efficiencies since wasted energy from the process is harnessed for heating purposes. Harnessing waste heat from industrial processes and incineration of solid waste are also appealing options for district heating, due to a reduced or eliminated need for a fuel source for heat. Many large cities already incinerate their waste. The heat from this process which would be used for electricity generation, or simply be vented to the atmosphere, can be diverted to heat water for circulation. It has been shown that often there is not enough consistent heat produced in such a system to meet the demand in a large heating network, but incineration can meet up to 30% of the demand in an average network. (Werner, 2004) Waste heat reuse is also appealing due to its high efficiency, but again it is uncommon for a single source to be sufficient to meet the demands of a network. Often multiple sources or a combined system using other fuel must be used.

Natural gas is a common choice for district heating due to the fact that often the fuel is already easily available through a distribution network in urban areas. Natural gas is sometimes seen as less desirable due to the fact that it is a non-renewable resource; however, it is still a viable option which can result in significant energy savings and reduction of emissions over individual heating systems.

## **Combined District Heating and Cooling**

A combined system is usually a more efficient choice than having separate systems in any scenario where both heat and cooling are in relatively high demand throughout the year. Combined systems use the same principles discussed above, except they both run off of the same source of heat or energy, thereby reducing the cost of installing separate systems, since demand for space heating and cooling are typically offset according to the season. (Werner, 2004) These systems also use the same infrastructure and same piping systems, which greatly reduces the capital cost of installation compared to installing separate systems.

### ***Potential Benefits***

All of the systems discussed above represent reduced energy consumption compared to individual systems used for space heating or cooling. Quantified energy savings are difficult to estimate, since energy usage of the system varies greatly according to scale of the project, source of energy, type of chillers/heaters, and many other variables.

### **District Heating**

- (EDAW, 2008) – A case study in Vancouver suggested a reduction of about 15% in energy usage by switching a downtown area to district heat
- (Kanoglu, 1998) – In one study a typical geothermal power plant was analyzed and found that the plant achieved only about 10% efficiency for power generation. A system was designed that could supply heat to an entire industrial park, using only the waste heat from the geothermal extraction.

- (Erdem, 2009) – One study found that coal powered generators in a power plant wastes approximately 2/3 of the heat generated. A cogeneration plan designed to make use of this heat could potentially draw all power needed for a district heating system from this waste heat without negatively affecting electricity generation. Also, with as little as a 10% decrease in electricity production (4MW in the case study), the heating power could be increased significantly (30 MW of heat potential, including waste heat).
- (Difs, 2009) – In Linköping, Sweden it was determined that if an industrial park switched entirely to district heat, and cooling powered by absorption chillers using the district heat, the potential energy savings was about 30% of current usage in the park.
- (IDEA, 2002, “UCLA”) – The University of California Los Angeles Campus reduced overall emissions by 34% with the installation of a landfill gas cogeneration system providing electricity and district heat.

## **District Cooling**

- (Hawaii, 2002) – case study in Hawaii indicated that a sea water cooling system used about 10% of the energy needed to cool the same area using electrical air conditioning systems
- (Zogg, 2008) – across the US, if 10% of cooling demand was supplied by lake source cooling (LSC), the total energy demand by chillers yearly would be reduced by 8%. Found that LSC saves about 83% energy compared to high efficiency electric chillers
- (Lupton, 2008) – estimated that in Hamilton, Ontario switching to an electrically powered district cooling network would reduce energy used for space cooling by 41%
- (IDEA, 2002, “Cornell”) – A case study on Cornell University showed that a lake source cooling system met the same demand as the previously installed

- campus wide cooling system using electricity powered chillers, yet the lake source system used only 13% of the energy needed to power the old system.
- (Shimoda, 2008) – A detailed simulation of a district energy system showed that the cooling system used 8% less energy overall than the individual cooling systems used in comparison.
  - (Chow, 2004, “Energy Modeling”) – it was found that a district cooling system in Hong Kong could save between 20% and 30% of energy by employing a sea source system versus an air cooled system
  - (Hanson, 2007) – In Dubai, it has been estimated that 75% of all energy is used for space cooling. The installation of district cooling in the city is projected to save as much as 40% of the cooling energy used.

## **Combined Systems**

- (Rosen, 2004) – Indicated that energy production for Edmonton can improve efficiency from 35% to between 55%-80% with waste heat powered system
- (Aspen, 2000) – Estimated that natural gas engines achieve 35% efficiency without heat recovery, and 79% efficiency with heat recovery
- (Wang, 2009) – It was found that optimization of a combined system could result in drops of 19.7% in energy consumption, 12.8% in energy cost, and 29.6% CO<sub>2</sub> emissions

The amount of energy saved relates largely to the type of fuel used for the system. Waste heat recovery systems usually require little electricity to operate, but they may put additional stress on the system they are removing heat from, costing energy. Switching to district energy represents a significant reduction in emissions as well, usually as a direct result of the energy savings. Any pollutant reduction associated with the use of district energy is dependant on the local source of electricity.

District energy systems are also ideal for harnessing the power of alternative energy sources such as geothermal heat or biogas. Their larger scale allows them to make use of these energy sources in a way individual consumers could not. Converting these energy sources directly into heat for a district heat system or an absorption chiller district cooling system can represent significant efficiency gains over using these sources to generate power, then converting that power back to heat after transmission from the power plant to the district energy distribution station.

One of the intangible benefits of a district heating system is that it eliminates the need for air conditioning equipment within a building. This frees up space on the roof and in mechanical rooms, which can be used for other things, or not even designed into the building in the first place. This also means that there is no need to budget for operations and maintenance to the equipment. The only cost associated with space heating and cooling is now a fixed rate that each building pays according to usage.

### ***Potential Risks and Considerations***

A potential environmental impact is if the system used sea or lake cooling, because the water being deposited back into the source will be warmer than the surrounding area. This can potentially cause problems with the local ecosystem, and should be carefully considered when planning this type of system. (Chow, 2004, "Applying District Cooling")

A human health concern that may arise from this system is the possibility of Legionnaire's disease. This affliction is caused by bacteria that live in water. The danger is where the air handling system for a building cools or warms the air by passing it directly over or through the water distributed by the system. This can allow the bacteria to become airborne in an aerosol of water. Inhaling the bacteria can lead to a number of symptoms. These are usually are no more than a mild flu, but can sometimes lead to sever pneumonia, a potentially serious or fatal condition. Although outbreaks of this

disease are rare, there are a number of measures that should be taken to avoid it, such as filtering water in the closed loop system, and avoiding any system components which allow some of the water to stagnate. (Ottawa, 2009)

## ***Estimated Costs***

The cost of a district cooling system is difficult to estimate. It varies based on the size of the system, the demand of the area being serviced, and the type of system and equipment selected among other things.

- (EDAW, 2008) – In Vancouver a system that supplies about 6 MW of heat to 1 million sq ft of mixed use buildings cost 8 million dollars (in 2003)
- (Lupton, 2008) – Hamilton, Ontario: system will save about \$181,000 per year in energy production costs, system will cost \$8.5 million to install
- (IDEA, 2002, “Cornell”) – Cornell University Lake Source Cooling System: \$58 million to install and maintain system for two years – services 13 million sq ft with 16,000 tons of cooling capacity
- (Shuman, 2005) – A proposed biomass powered heating facility to service the city of Santa Fe, New Mexico will cost \$23.5 Million
- (Chow, 2005) – a district cooling facility in Hong Kong incorporating seasonal ice storage will cost HK\$163.07 million, where one without ice storage would cost HK\$125.88 million. Able to meet a maximum cooling load of 116 MW
- (IDEA, 2002, “UCLA”) – A landfill gas powered cogeneration system for UCLA has a power capacity of 34 MW. It produces 234 MMBTUs/hour heating capacity and has a cooling capacity of 16,600 tons. Cost of the system was \$188 million

The capital cost of a district energy system is typically very high, and the pay back period may be long. Optimization of the plant should be an ongoing goal of the



operators of such a facility, to ensure that the payback period is shortened as much as possible. (Chow, 2004, "Energy Modeling")

Additionally, it is possible for the cost of heating or cooling to go up slightly for customers compared to the old systems. (Difs, 2007) This may present a barrier to the construction of district energy facilities, and can be minimized by negotiating tariffs and taxes with the local government to try and bring down the price of such a system. Systems are limited in their size, because past a certain point the thermal losses through the pipes become great enough that the system is no longer effective. (Kanoglu, 1998)

### ***Recommended Site Characteristics***

A full analysis is usually needed to determine the feasibility of a district energy system, but there are several indicators that usually are present for an appropriate site. For a combined system to be economical there must be a significant change in climate through the seasons, so that both systems will be worth the capital cost of their installation. For a cooling system to be effective, the best environments are tropical and sub-tropical climates. Areas further from the equator may still have a high enough cooling demand to make the system worthwhile, but careful analysis will be needed to determine if the system will be cost effective. Heating systems are the opposite, and are most efficient in environments that experience high heating demand for extended periods throughout the year.

Other factors that affect the placement of a district energy facility are proximity to water for lake or sea cooling, and density of the area being serviced. High density urban areas reduce the amount of pipe to be laid to service the same number of customers. An urban area is also more likely to have access to waste heat from industrial processes, or incineration of waste.

## **Potential LEED Credits**

District energy is not a technology that can be applied to a building being constructed, but it is rather a large public infrastructure project. LEED accreditation should be a goal for a district energy project, but district energy will generally not be a choice that a builder can make in order to achieve LEED credits.

## **Relevant Stantec Projects**

Below is a list of projects that have been undertaken by Stantec that may be useful references when designing a district cooling or heating system. Other relevant projects can be found in the Stantec Marketing Knowledge Center.

### **1. 25 MW Biomass Power Project**

Location: Grand Prairie, Alberta, Ca

Description: A combined Heat and Power project which will be fueled by wood waste from a lumber mill. Facility will generate power, heat to power wood mill, and heat to distribute for district heating.

Link: [http://marketingexcellence/projectprofile\\_preview.aspx?id=10&project=1454](http://marketingexcellence/projectprofile_preview.aspx?id=10&project=1454)

### **2. Lower Lonsdale District Energy System**

Location: North Vancouver, British Columbia, Ca

Description: A district heating system that uses five small facilities that reheat and recalculate water with small, efficient natural gas boilers.

Link: [http://marketingexcellence/projectprofile\\_preview.aspx?id=10&project=9648](http://marketingexcellence/projectprofile_preview.aspx?id=10&project=9648)

### **3. North East Coquitlam District Energy Study**

Location: Coquitlam, British Columbia, Ca

Description: A study on the feasibility of a district heating system. Recommended option was a geothermal system.

Link: [http://marketingexcellence/projectprofile\\_preview.aspx?id=10&project=10321#](http://marketingexcellence/projectprofile_preview.aspx?id=10&project=10321#)

### **4. Charlottetown Energy-from-Waste Facility**

Location: Charlottetown, Nova Scotia, Ca

Description: A district heating plant powered mainly by solid waste incineration. Facility cogenerates electricity to power its own systems. Serves more than 84 buildings in the Charlottetown waterfront.

Link: [http://marketingexcellence/projectprofile\\_preview.aspx?id=10&project=16627](http://marketingexcellence/projectprofile_preview.aspx?id=10&project=16627)

### **5. Bay Area Health Trust and Hamilton Health Sciences Cogeneration Projects**

Location: Hamilton, Ontario, Ca

Description: Provided a technical analysis of cogeneration systems installed in several medical buildings in Hamilton. Systems include waste heat capture and absorption chilling system to save energy.

Link: [http://marketingexcellence/projectprofile\\_preview.aspx?id=10&project=15506](http://marketingexcellence/projectprofile_preview.aspx?id=10&project=15506)

### **6. Calgary Public Building Renovation – Mechanical**

Location: Calgary, Alberta, Ca

Description: Updated a historical building in Calgary with many sustainable features, including a hookup to a district heating system.

Link: [http://marketingexcellence/projectprofile\\_preview.aspx?id=10&project=17726](http://marketingexcellence/projectprofile_preview.aspx?id=10&project=17726)

## Sources

1. Aspen Systems Corporation "Combined Heat & Power: A Federal Manager's Resource Guide" U.S. Department of Energy. Mar. 2000, Accessed on Feb.1, 2010. [http://www.eere.energy.gov/de/pdfs/chp\\_femp.pdf](http://www.eere.energy.gov/de/pdfs/chp_femp.pdf)

*A government overview of the district energy technology, with case studies*

2. Chow, T.T. et al. "Applying district-cooling technology in Hong Kong" Jan. 2004. Accessed Jan. 19, 2010. Available at <http://www.sciencedirect.com>

*Addresses a case study of a district cooling system in Hong Kong. Has discussion of sea water cooling input and output temperatures*

3. Chow, T.T. et al. "Performance evaluation of district cooling plant with ice storage" July 2005. Accessed Jan. 20, 2010. Available at <http://www.sciencedirect.com>

*Describes how to optimize a district cooling plant using thermal storage, and applies this methodology to a specific plant in Hong Kong*

4. Chow, T.T. et al. "Energy modeling of district cooling system for new urban development" Feb. 2004. Accessed Jan. 25, 2010. Available at <http://www.sciencedirect.com>

*Confirms that green roofs are most applicable to urban environments in regions with warm climates*

5. Difs, Kristina and Trygg, Louise. "Pricing district heating by marginal cost" Dec. 2007. Accessed on Feb. 1, 2010. Available at <http://www.sciencedirect.com>

*Prices out a switch from individual electric heat to a DH system*

6. Dotzauer, Erik. "Simple model for prediction of loads in district-heating systems" Aug. 2002. Accessed Jan. 25, 2010. Available at <http://www.sciencedirect.com>

*Discusses how outdoor temperature is the largest factor in the effectiveness of district heating/cooling, and how it affects the load on the system, along with social traits of customers*

7. EDAW, Inc. "Case Study: Vancouver's District Heating Program". Nov. 2008. Accessed Jan. 25, 2010. [http://www.seattle.gov/environment/documents/GBTF\\_NewBldg\\_Vancouver\\_Heating\\_Case\\_Study.pdf](http://www.seattle.gov/environment/documents/GBTF_NewBldg_Vancouver_Heating_Case_Study.pdf)

*An overview of Vancouver's district heating program, including costs and evaluation*

8. Erdem, Hasan Huseyin et al. "Thermodynamic analysis of an existing coal-fired power plant for district heating/cooling application" Apr. 2009. Accessed Jan. 26, 2010. Available at <http://www.sciencedirect.com>

*Discusses how to use the waste heat from coal power generation for cogeneration of district heating and cooling.*

9. Eriksson, Ola et al. "Life cycle assessment of fuels for district heating: A comparison of waste incineration, biomass- and natural gas combustion" June, 2006. Accessed on Feb.1, 2010. Available at <http://www.sciencedirect.com>

*Compares heat and power generation, and cost, of natural gas, incineration, and biomass CHP systems versus just DH systems*

10. Hanson, Susanna S. "District Cooling Systems" 2007. Accessed on Jan.29, 2010. <http://www.engnetbase.com/books/6205/DK653Xch42.pdf>

*Discusses the potential wasted energy resulting from addressing chiller efficiency by itself without considering the district cooling system as a whole.*

11. Hawaii, State of: Department of Business, Economic Development & Tourism - Energy, Resources, and Technology Division. "Sea Water District Cooling Feasibility Analysis for the State of Hawaii". Oct. 2002. Accessed Jan. 26, 2010. - <http://hawaii.gov/dbedt/info/energy/publications/swac.pdf>

*Case study on the feasibility of a district cooling system for Hawaii. System would be sea water cooled.*

12. IDEA (International District Energy Association). "Combined Heat and Power Case Studies: Cornell University" Nov. 2002. Accessed Jan 27, 2010. <http://www.districtenergy.org/case-studies>

*An overview of the lake source district cooling system installed on the Cornell university campus*

13. IDEA (International District Energy Association). "Combined Heat and Power Case Studies: University of California: Los Angeles" Nov. 2002. Accessed Feb. 1, 2010. [http://www.districtenergy.org/assets/pdfs/CHP\\_Case\\_Studies/ucla.pdf](http://www.districtenergy.org/assets/pdfs/CHP_Case_Studies/ucla.pdf)

*An overview of the CHP system that serves UCLA*

14. Kanoglu, M. et al. "Incorporating a District Heating/Cooling System Into an Existing Geothermal Power Plant" June, 1998. Accessed on Jan 27, 2010. Accessible at [www.asme.org](http://www.asme.org)

*A case study on the feasibility of incorporating a combined district heating/cooling system into an existing geothermal power plant in Reno, Nevada.*

15. Lupton, Geoff. "District Cooling System and Chiller Selection" Sept. 2008. Accessed on Jan 27, 2010. <http://www.hamilton.ca/NR/rdonlyres/6C44FDCCD-1A5E-46B0-BE5B-751FAA287480/0/Sep15PW08109.pdf>

*Introduces the concept of district cooling to the town council of Hamilton, and proposes a specific project which has been fully budgeted and analyzed for cost/benefits*

16. Mahone, Douglas et al. "Absorption Chillers" The New Buildings Institute. Nov, 1998. Accessed Feb. 11, 2010. <http://www.newbuildings.org/downloads/guidelines/AbsorptionChillerGuideline.pdf>

*Describes all aspects of absorption chillers*

17. McQuay Air Conditioning. "Centrifugal Chiller Fundamentals" 2000. Accessed on Jan.29, 2010.

[http://www.mcquay.com/mcquaybiz/literature/lit\\_corporate/AppGuide/AG\\_31\\_002.pdf](http://www.mcquay.com/mcquaybiz/literature/lit_corporate/AppGuide/AG_31_002.pdf)

*A manual detailing the function of a centrifugal water chiller.*

18. Ottawa, University of "Legionnaires Disease - Information Sheet" Nov. 2009. Accessed on Feb. 1, 2010. <http://www.uottawa.ca/services/ehss/legionnaires.htm>

*Gives the basic fact about the symptoms and transmission of legionnaires disease*

19. Patil, Anish et al. "Sustainable District Heating System: A Multi-Actor Perspective" 2006. Accessed Jan. 26, 2010. Available at <http://ieeexplore.ieee.org>

*An analysis on a theoretical project on how to make a district heating project feasible by getting the right parties involved in its planning and initiation*

20. Pöyry Energy Consulting "The Potential and Costs of District Heating Networks" The Department of Energy and Climate Change". 2009. Accessed Jan. 25, 2010. [http://www.decc.gov.uk/Media/viewfile.ashx?FilePath=What%20we%20do/UK%20energy%20supply/Energy%20mix/Distributed%20Energy%20Heat/1\\_20090505121831\\_e\\_@\\_204AreportprovidingatechnicalanalysisandcostingofDHnetworksv30.pdf&filetype=4](http://www.decc.gov.uk/Media/viewfile.ashx?FilePath=What%20we%20do/UK%20energy%20supply/Energy%20mix/Distributed%20Energy%20Heat/1_20090505121831_e_@_204AreportprovidingatechnicalanalysisandcostingofDHnetworksv30.pdf&filetype=4)

*A report prepared for the department of energy and climate change in the UK, detailing a cost benefit analysis of district heating*



21. Rosen Marc A. et al. "Efficiency analysis of a cogeneration and district energy system" June, 2004. Accessed on Feb.1, 2010. Available at <http://www.sciencedirect.com>

*A case study of combined heat and power system in Edmonton, Alberta.*

22. Shimoda, Yoshiyuki et al. "Verification of energy efficiency of district heating and cooling system by simulation considering design and operation parameters" Nov. 2005. Accessed Jan. 19, 2010. Available at <http://www.sciencedirect.com>

*Analyzes the efficiency of combined district heating and cooling plants*

23. Shuman, Michael H. "Economics of Proposed Biomass-fired District Heating System for Santa Fe, New Mexico" Nov. 2005. Accessed Jan. 26, 2010. <http://small-mart.org/files/Santa-Fe-Biomass-Paper.pdf>

*Provides a cost benefit analysis of a potential biomass powered district heat system with a focus on comparison of the biomass technology to other heat sources*

24. Tanaka, Hideki et al. "Feasibility Study of a District Energy System with Seasonal Water Thermal Storage". 2000. Accessed Jan. 26, 2010. Available at <http://www.sciencedirect.com>

*Three systems are analyzed for their coefficient of performance to determine feasibility of the design. Two use waste heat, one does not. The two with waste heat have different types of thermal storage. The seasonal storage is more efficient.*

25. Thorsteinsson, Hildigunnur H. and Tester, Jefferson W. "Barriers and Enablers to Geothermal District Heating System Development in the United States". Dec. 2008. Accessed Feb. 24, 2010. Available at <http://www.sciencedirect.com>

*A paper discussing the possibility of geothermal district heating in the United States, technologically and politically, and compares the district heating system in Iceland to the US.*

26. Vitooraporn, Chirdpun and Jiratthitijaroen, Worachat. "District Cooling Plant: Refrigeration Plant Simulation" Sept. 2001. Accessed on Jan.29, 2010. [http://www.ashraethailand.org/download/ashraethailand\\_org/pub\\_chirdpun.districtcooling.pdf](http://www.ashraethailand.org/download/ashraethailand_org/pub_chirdpun.districtcooling.pdf)

*Describes how to use computer simulations to determine the most efficient plant layout for a district cooling system*

27. Wang, Fulin et al. "Methodology for optimizing the operation of heating/cooling plants with multi-heat-source equipments" July 2008. Accessed Jan. 19, 2010. Available at <http://www.sciencedirect.com>

*Describes how Optimization of a cooling system by careful planning and prioritization of machines can result in significant energy savings at almost zero cost*

28. Werner, Sven. "District Heating and Cooling" 2004. Accessed Jan. 20, 2010. Available at <http://www.sciencedirect.com>

*Gives a good overview of the district heating/cooling technology in terms of technology and applicability to our society*

29. Zogg, Robert et al. "Lake-Source District Cooling Systems" Feb. 2008. Accessed Jan. 28, 2010.

<http://bookstore.ashrae.biz/journal/download.php?file=Emerging022008.pdf>

*Samples several case studies that used lake source district cooling*

## Air Handler Condensate Recovery System

According to the U.S. Geological Survey, the United States uses about 400 billion gallons of water per day. While the majority is used for thermoelectric power generation (48%) and farm irrigation (34%), buildings account for about 47 billion gallons per day, or 12% of U.S. water use (Wilson, 2008). Figure 38 shown below demonstrates the water usage of commercial buildings.

End Use of Water in Commercial Buildings

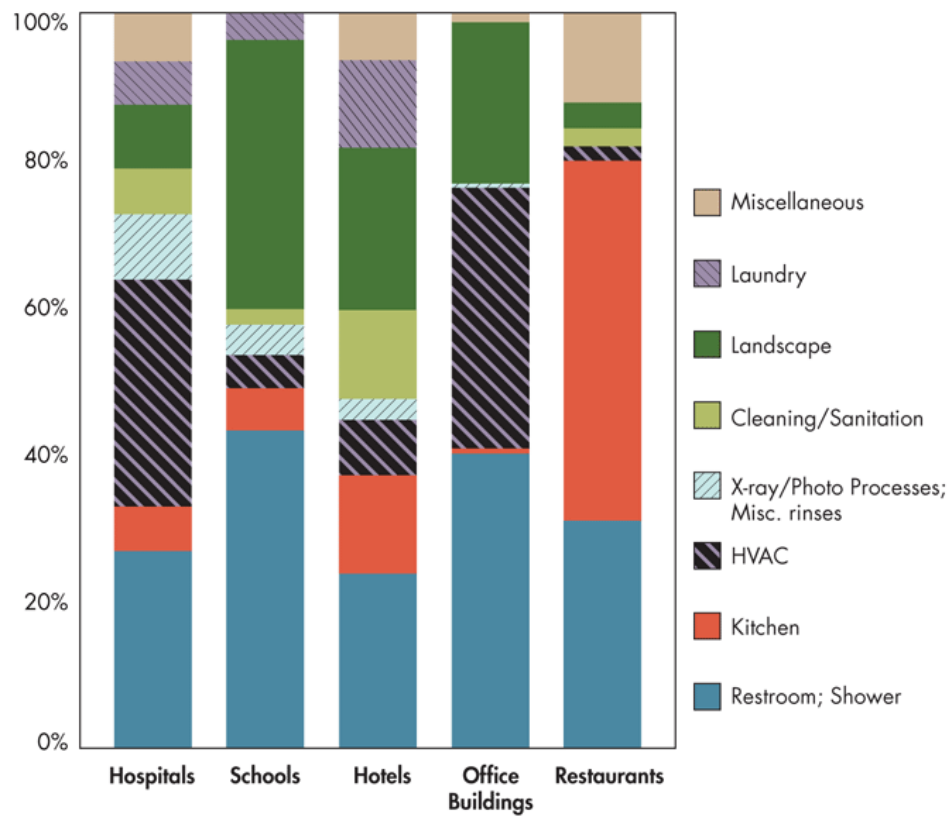

Source: Awwa Research Foundation

Figure 38: End Use of Water in Commercial Buildings (Wilson, 2008)

The excessive usage of this natural resource has caused a drastic reduction in its availability. The implications of this became widely apparent when the severe 2007

drought throughout the southeast U.S. demonstrated the need of implementing water conservation practices. As data is used to predict the future availability of this resource, the urgency of sustainable water management is put into perspective. For example, “a new report in the journal *Water Resources Research* forecasts a 50% likelihood that Lake Mead and Lake Powell [of the Colorado River] will essentially run dry by 2021. 25 million people in seven states, including the city of Las Vegas, get their water from these sources” (Wilson, 2008). Furthermore, a 2003 report by the U.S. General Accounting Office reported that 36 states are likely to experience water shortages by 2013 (Wilson, 2008).

Given such strong indications that water resources will continue to decrease, sustainable water management practices are crucial. In addition to simply conserving water, it is also important to find alternative sources of water, including those which can be harvested and reused at the building level. This section discusses the potential of a relatively new technology which exemplifies the opportunities for discovering such sources.

### ***Technical Description***

Most conventional cooling systems produce water as a byproduct, which can be recovered and put to good use. In order to produce cool air from a compressed refrigerant, a set of coils allow a hot, high-pressured refrigerant to dissipate its heat and condense into a liquid. An expansion valve is then typically used to evaporate and cool the refrigerant. This cool gas then runs through a set of coils that allow it to absorb heat and cool the air, which is blown over the coils and into the inside of the building.

This process cools the warm coils, so when the warm air blowing past the coils reaches its dew point the moisture in the air condenses onto the coils, producing what is essentially distilled water (Brian, 2000). This byproduct of air conditioning units can be captured and reused through an air handler condensate recovery system (Wilson,

2008). An example of this is shown in Figure 2 which demonstrates a schematic of the recovery system used in the U.S. Environmental Protection Agency's (EPA) Science and Ecosystem Support Division (SESD) building in Athens, Georgia. In this example, the condensate recovered from the air handling units (AHU) was used for cooling tower make-up (EPA, 2009).

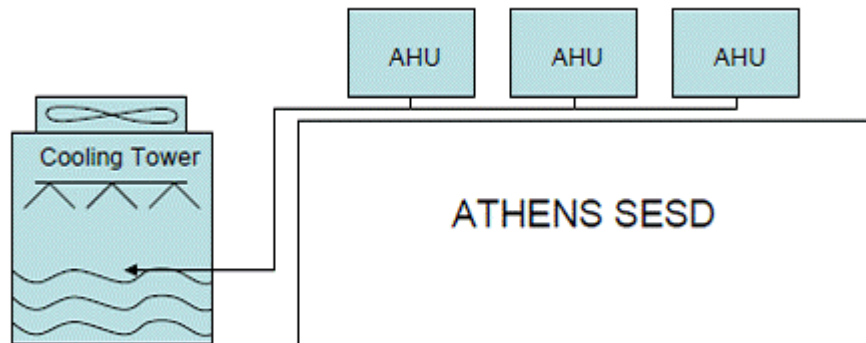

**Figure 39: Example of an Air Handler Condensate Recovery System (EPA, 2009)**

As previously mentioned, the quality of condensate created by air handlers is typically very high, having low amounts of suspended solids, a neutral to slightly acidic pH, and low temperatures. In 2007 a recovery system used by the Winship Cancer Institute (WCI) of Emory University in Atlanta, Georgia showed that the recovered condensate entered the cooling towers between 50 and 60 degrees Fahrenheit (EPA, 2007). These characteristics make the condensate adequate for several non-potable uses such as irrigation, cooling tower make-up, or toilet flushing. In addition to quality water, high recovery capacity is a major benefit of these systems. Although the amount of condensate produced can vary greatly and depends on the size and operational load of the cooling system as well as the ambient temperature and humidity within a particular region, several case studies outlined in Table 24 show impressive amounts ranging from 100,000 gallons per year to 7,000,000 gallons per year. A rule of thumb created by Karen Guz (director of the Conservation Department for the San Antonio Water System) is that 0.1 - 0.3 gallons of condensate per ton of air being chilled is produced every hour that the system is operating (Wilson, 2008). Seizing this

opportunity by replacing or supplementing potable water with the recovered condensate can considerably reduce a building's demand for potable water. For example, the U.S. EPA has implemented this technology within 6 projects since 1996. These combined are estimated to save about 3.8 million gallons of water per year across the agency (EPA, 2009). Table 24 shown below, demonstrates the condensate recovery capacity of several projects throughout the United States.

**Table 24: Condensation Collection Facility Data (SCTRWPG, 2008)**

Condensate Collection Project	Location	Building Area (ft <sup>2</sup> )	Average Summer Afternoon Humidity	Average High Summer Temperature (degrees F)	Annual Condensate Recovery Volume (gal/yr)
Sea World Game Center	San Antonio, TX	28,000	57%	91	140,000
Houston EPA Laboratory	Houston, TX	39,408	62%	88	138,333
EPA Gulf Ecology Division Laboratories	Gulf Breeze, FL	79,450	62%	85	100,000
Emory University Winship Cancer Institute	Atlanta, GA	200,000	57%	80	900,000
Fulton County Health Center	Wauseon, OH	281,500	56%	73	353,000
Duke University Gross Chemistry Center and Levine Science Resource Center	Durham, NC	430,000	57%	80	7,000,000

**DRAFT, 8/7/2008** **4**

While the overall concept of condensate recovery systems is relatively simple, complexities can vary depending on the use of the captured condensate. When condensate recovery systems are used to make-up for evaporative losses in cooling towers, a simple gravity flow system, like the one shown in Figure 2 can be implemented (Wilson, 2008). In this type of system all units are connected to a central point in the penthouse by a drain line which then connects to a second line that runs to the cooling towers below (EPA, 2007). Because condensate recovery does not usually

exceed the evaporative losses within cooling towers a 3-way valve can be installed to monitor how much water the cooling system uses and can regulate the amount of condensate entering the system. In the rare case of excess condensate the overflow can be drained to a sewer. A similar recovery system used by the WCI has a two way valve on every unit to allow this type of water management (EPA, 2007).

Although their design depends greatly on the condensate production rate and specific landscape irrigation needs, systems in which the recovered condensate is used for irrigation tend to be more complex and expensive. This is true because of the need for a pressurizing system, additional piping, and relatively larger storage tanks. However landscape irrigation accounts for a substantial amount of the building's overall water consumption and therefore, condensate recovery systems could be used to meet some of this demand. In order to make irrigation a more feasible option, such systems can be combined with a rainwater harvesting system as this can decrease the required size of storage tanks (Wilson, 2008). This combination is becoming very common in San Antonio, Texas where the city refers to it as "rainwater plus". According to Guz, "[San Antonio's] rainfall patterns are so erratic that a rainwater system by itself must have an enormous, expensive tank in order to go through the long periods without rain. Because the production of condensate is fairly steady, and increases as the weather gets hotter, smaller storage tanks are sufficient" (Wilson, 2008). Other strategies such as water efficient landscaping techniques (xeriscaping) could also be implemented to decrease the amount of water used during irrigation. This could increase the cost-effectiveness of more complex systems.

### ***Potential Benefits***

By implementing a condensate recovery system free, clean, and unused water will be replacing costly, treated, high demand potable water. Decreasing the use of potable water within buildings plays a major role in conserving municipal water sources.



The following lists the potential benefits of water conservation as outlined by “Realizing the Benefits from Water Conservation” (Maddaus, 2001):

- Decreased municipal water system operating costs.
- Reduced withdrawals from supply sources.
- Reduced discharge of treated wastewater to receiving waters.
- Influence over the water supply and wastewater facility designs.
- Decreased environmental impacts of construction due to smaller water treatment facilities.
- Potential savings in utility bills.
- Lower energy consumption can have secondary benefits by reducing energy production.
- Reduced wastewater flows mean that less effluent must be disposed of, often with some environmental impacts.
- Water is left in rivers, reservoirs, groundwater basins where it can be used for enhancing environmental purposes.

### ***Potential Risks/Downsides***

It is important to note that although the condensate is usually pure there is risk of contamination through bacteria build-up in pipes and storage tanks. In such cases, wastewater treatment chemicals are used to treat the condensate. This can have a detrimental effect on plants if the condensate is used for irrigation. The potential of employing UV treatment can be investigated as one way to eliminate this risk.

According to the South Central Texas Regional Water Planning Group (SCTRWPG) the following risks are associated with condensate recovery systems:

- Dust and Algae Problems
  - Clogged Drains

- Condensation Pump Motor Failure
- Overflows
- Quality problems with collected water
- Potential risk of mold problems
- Reduces peak water use, but not a conventional firm supply as air condition use is limited in the cooler months between November and March (SCTRWPG, 2008)

### ***Estimated Costs***

Although there is very limited data available on the costs of these systems, most estimates are heavily dependant on the size and the use of the recovered condensate. For example, recovery systems in San Antonio, Texas have ranged from \$US 6,000 to over \$US 30,000 (Weynard, 2009). However, condensate recovery systems can be designed at significantly lower and higher costs. When the condensate is used to replace evaporative losses from a cooling-tower the costs are significantly lower than when it is used for irrigation. However, in both cases the overall costs heavily depend on the position and distance between the air handling units and the final destination of the recovered condensate as this dramatically affects the cost of piping. The following describes the capacity and costs of several condensate recovery projects.

Houston, Texas EPA's Environmental Services Branch Laboratory (1996)

- Collection Potential: 831,600 gallons/year
- Water and Sewage Savings: \$20,000 over 6 years
- Total Cost: \$6,000.00
- Simple Payback period: NA

San Antonio River Center Mall (2003)

- Collection Potential: 12,000,000 gallons/year
- Water and Sewage Savings: \$49,500/year

- Total Cost: \$32,058.00
- Simple Payback period: 8 months

#### San Antonio HEB Grocery Distribution Center (2003)

- Collection Potential: 6,200,00 gallons/year
- Water and Sewage Savings: \$20,600/year
- Total Cost: \$19,000.00
- Simple Payback period: 11 months

#### Winship Cancer Institute (2004)

- Collection Potential: 900,000 gallons/year
- Water and Sewage Savings: \$4,860.00/year
- Total Cost: \$45,000.00
- Simple Payback period: 5-9 years depending on water costs

In an attempt to prepare preliminary cost estimates of condensate recovery systems, the South Central Texas Regional Water Planning Group analyzed several case studies. They concluded that unit costs are roughly US \$1,700.00 per acre feet of condensate produced per year. This value assumes amortization over 30 years and is based on a system used by a 130,000 square foot facility that could produce 2.6 acre feet per year of water (SCTRWPG, 2008).

### ***Recommended Site Characteristics***

Air conditioning condensate recovery is most practical in climates with high humidity during the warm season. Since the maximum benefits are obtained through the maximum collection of condensate larger buildings with high cooling loads within humid regions are the most suitable for these systems. For example in San Antonio during

peak summertime months about 0.5–0.6 gallons per hour for every 1,000 ft<sup>2</sup> of cooled area (20–24 l/hr per 1,000 m<sup>2</sup>) can be captured (Wilson, 2008).

Although buildings in areas which are typically hot and humid can produce greater amounts of condensate there are many places outside of year-round warm climates that experience high humidity at the same time as their highest cooling loads. Specifically bigger buildings within major cities like New York and Philadelphia experience this situation. These systems can be equally beneficial for such buildings. Since condensate recovery is maximized when there is a high degree of air exchange facilities like shopping centers are especially suitable for condensate recovery systems.

### ***Potential LEED Credits***

#### Water Efficient Landscaping

- WE Credit 1.1
- WE Credit 1.2 (Tolat, 2008)

## Sources

1. Brian, Marshal; Bryant, Charles, "How Air Conditioners Work", 2000, Accessed Jan 25, 2010, Available at <http://home.howstuffworks.com/ac.htm#>
2. EPA, "Air Handler Condensate Recovery at EPA", 2009, Accessed Jan. 25, 2010, Available at <http://www.epa.gov/oaintrnt/water/airhandler.htm>
3. EPA, "Process Water Efficiency, HEALTHCARE - TOP 5 GREEN BUILDING STRATEGIES" 2007, Accessed Jan. 26, 2010. Available at: <http://www.epa.gov/region09/waste/p2/pdf/water-final-071126.pdf>
4. EPA, "Top 10 Water Management Techniques", 2010, Accessed Feb.23, 2010. <http://www.epa.gov/oaintrnt/water/techniques.htm#ten>
5. Johnson, Gregory. "HVAC Design for Sustainable Lab". 2008, Accessed Feb. 23, 2010. [http://www.ashrae.org/members/doc/ASHRAEDAJ08Sep0120080828\\_8090903.pdf](http://www.ashrae.org/members/doc/ASHRAEDAJ08Sep0120080828_8090903.pdf)
6. Maddaus, William. "Realizing the Benefits from Water Conservation". 2001, Accessed Feb. 23, 2010. [http://www.ucowr.siu.edu/updates/pdf/V114\\_A2.pdf](http://www.ucowr.siu.edu/updates/pdf/V114_A2.pdf)
7. South Central Texas Regional Water Planning Group. "2011 South Central Texas Regional Water Plan". 2008, Accessed Feb. 23. 2010. <http://www.regionltexas.org/documents/meetingdocs/2008/Enhanced%20Water%20Conservation,%20Drought%20Management,%20and%20Land%20Stewardship.pdf>

8. Tolat, Deepa. "Using LEED on Laboratory Projects". 2008. Accessed Feb. 23, 2010. <http://www.wbdg.org/resources/lableed.php>
9. Weynard, Phil. "Condensate-Free Water" October 9, 2009. Accessed Jan. 20, 2010. Available at <http://www.watersmartinnovations.com/2009/PDFs/F-1014.pdf>
10. Wilson, Alex; Navaro, Rachel. "Alternative Water Sources: Supply-Side Solutions for Green Buildings" May 1, 2008. Accessed Jan. 20, 2010. <http://www.buildinggreen.com/auth/article.cfm/ID/3903/>
11. Wilson, Alex; Navaro, Rachel. "Water: Doing More with Less". 2008, Accessed Feb. 23, 2010. <http://www.buildinggreen.com/auth/article.cfm/2008/2/3/Water-Doing-More-With-Less/>

**Appendix B: Report Compiled for Jamaica Project**

# **Downtown Redevelopment in Kingston, Jamaica**

Peter Cacciatore  
James Hogan  
Rebecca Mattern  
Angel Munoz

January 21, 2010



## Table of Contents

Appendix B: Report Compiled for Jamaica Project .....	294
Table of Contents .....	296
Solar Street Lighting.....	299
Technical Description .....	299
Costs and Benefits.....	299
Evidence.....	300
Sources .....	300
Bus Rapid Transit – Public Transportation .....	301
Technical Description .....	301
Costs and Benefits.....	301
Evidence.....	302
Sources .....	303
Mixed-use Community.....	304
Description.....	304
Costs and Benefits.....	304
Evidence.....	305
Sources .....	305
Geothermal Power .....	307
Technical Description .....	307
Costs and Benefits.....	307
Evidence.....	308
Sources .....	309
Solar Power.....	310
Technical Description .....	310
Photovoltaic Power (PV) .....	310
Concentrated Solar Power (CSP) .....	311
Costs and Benefits.....	311
Evidence.....	312

Sources .....	312
Wind Power .....	314
Technical Description .....	314
On-Shore .....	314
Off-Shore .....	314
Costs and Benefits.....	315
Evidence .....	315
Sources .....	316
District Cooling .....	317
Technical Description .....	317
Costs and Benefits.....	318
Evidence .....	318
Sources .....	319
Green Roofs.....	321
Technical Description .....	321
Costs and Benefits.....	322
Evidence .....	323
Sources .....	323
Hydrothermal Potential.....	325
Waste Management .....	326
Technical Description .....	326
Costs and Benefits.....	327
Evidence .....	328
Sources .....	328
Rainwater Harvesting .....	330
Description.....	330
Cost/Benefits .....	330
Supporting Evidence.....	331
Sources .....	331
Grey Water Reuse.....	333
Description.....	333

Costs/Benefits .....	333
Evidence.....	334
Sources .....	335
Air Handler Condensate Recovery.....	337
Technical Description .....	337
Cost/Benefits .....	338
Evidence.....	338
Sources .....	339
Water-Efficient Plumbing Fixtures .....	340
Technical Description .....	340
Cost/Benefits .....	341
Evidence.....	341
Sources .....	342
Urban Gardens.....	344
Technical Description .....	344
Cost/Benefits .....	345
Evidence.....	345
Sources .....	346
Bio-Retention Areas .....	347
Technical Description .....	347
Cost/Benefits .....	348
Evidence.....	348
Sources .....	348
Collecting Recyclables From Citizens .....	350
Description.....	350
Cost/Benefits .....	351
Supporting Evidence.....	351
Sources .....	352

## **Solar Street Lighting**

Solar-powered street lights provide adequate and sustainable lighting for a safer community.

### ***Technical Description***

Flat Panel Street Lighting – The system mounts on any standard pole. A typical unit includes a 100 to 400 watt solar panel, a waterproof battery casing, and a 100 Ah battery.

Security Perimeter Lighting – The system mounts on any fence or wall. A typical unit includes a 12 or 24 VDC (volts direct current) systems, a waterproof battery casing, and a 100 Ah battery.

### ***Costs and Benefits***

US \$2,500 per unit for Solar Panel Street Lighting

US \$2,500 per unit for Solar Security Perimeter Lighting

- ✓ Very durable - generally features weather and corrosion resistant material and tamper proof options for theft prevention.
- ✓ Can operate from dusk to dawn and/or on fixed running time.
- ✓ No line voltage, trenching, or metering.
- ✓ Immune to power outages.
- ✓ Both have battery back ups for cloudy days.
- ✓ Easy installation.
- ✓ Can aid in local crime reduction.

- ✓ Instills a feeling of safety amongst the community.

## ***Evidence***

In 2004, criminologist Brandon Welsh and David Farrington's in-depth study on Closed Circuit television (CCTV) versus lighting found: "Improved street lighting is an effective form of surveillance to reduce crime in public space and it has few, if any, perceived harmful social consequences."

In 1999, The Institution of Lighting Engineers (ILE) published "A Guide for Crime and Disorder Reduction through a Public Lighting Strategy" which concluded that lighting does reduce crime, in lieu of much skepticism.

## ***Sources***

Sol Inc. "Reliable. Renewable. Remarkable." 2009. Accessed Jan. 19 2010.

<http://www.solarlightingusa.com>

Tinus Kruger. "South African CPTED – Connecting People to Environment" 2009. Accessed Jan. 19 2010

<http://www.cpted.net/PDF/newsletters/april2009.pdf>

Paul Marchant. "Investigating whether a crime reduction measure works" 2006. Accessed Jan. 19 2010.

<http://www.radstats.org.uk/no091/Marchant91.pdf>

## **Bus Rapid Transit – Public Transportation**

The use of specialized busses which run on alternative fuels and within independent lanes can increase the usage and sustainability of Kingston's public transportation system.

### ***Technical Description***

Bus Rapid Transit (BRT) uses extra-long buses or specialized vehicles in designated lanes. This allows for swift and efficient transport of passengers. Due to the necessary designated lane, design arrangements must be prepared before construction begins. The BRT system can be customized to Kingston and incorporate low-cost modern technologies. The buses can accommodate alternative fuel, such as CNG (compressed natural gas), clean diesel, and hybrid electric. CNG tanks are heavy, but the vehicles are 5-15 percent more efficient than regular gasoline. Clean diesel Clean diesel engines are known to have better fuel economy and a longer engine life than standard gasoline engines. Hybrid electric vehicles have increased mileage and reduces emissions compared to a conventional automotive, but it can be slow and inconvenient to charge.

### ***Costs and Benefits***

The cost of these systems greatly varies depending on extent of construction and location.

Average capital cost per BRT vehicle (CNG): US \$2.6 million

Average capital cost per BRT vehicle (clean diesel): US \$1.1 million

Average capital cost per BRT vehicle (hybrid electric): US \$3.9 million

- ✓ BRT is 22 percent more cost effective than a standard bus per trip per km.
- ✓ Riding a bus is over 75 times safer than a personal automotive.
- ✓ Public transit emits less carbon & fuel per passenger than individual vehicles.
- ✓ BRT can use alternative fuel (clean diesel, hybrid electric, or CNG)
- ✓ Use of public transit aids to relieving traffic congestion.
- ✓ Facilitates community cohesion
- ✓ Reduces water pollution and resource consumption.
- ✓ Enhances economic prosperity and access to opportunity.
- ✓ Prepare Kingston to manage an increase in ridership due to a successful revitalization.
- ✓ Space may not be available for construction of the extra lane.

## ***Evidence***

A study by Breakthrough Technologies Institute in 2006 found that using BRT system in a medium sized US city will reduce carbon dioxide emissions by more than 650,000 tons over a 20 year period.

In 2009, studies in the Journal of Public Transportation stated that the shortened running time of the BRT compared to standard buses will attract ridership and help ensure the competitiveness of the transit line.

The American Public Transit Association published “The Benefits of Public Transportation – Relieving Traffic Congestion” in 2009. The study found that increased use of public transportation has positive economic, social, and environmental advantages to society.

## **Sources**

Larry West. "Public Transportation: Fast Track to Fewer Emissions and Energy Independence" 2009. Accessed Jan. 18 2010.

[http://environment.about.com/od/greenlivingdesign/a/public\\_transit.htm](http://environment.about.com/od/greenlivingdesign/a/public_transit.htm)

National Center for Transit Research. "Journal of Public Transportation" 2009. Accessed Jan. 18 2010.

<http://www.nctr.usf.edu/jpt/pdf/JPT12-3.pdf>

Metro Magazine. "Quick Fact Sheet" 2007. Accessed Jan. 18, 2010.

[http://www.nbrti.org/docs/pdf/metro\\_magazine.pdf](http://www.nbrti.org/docs/pdf/metro_magazine.pdf)

T. Michael French. "Compressed Natural Gas Vehicles" 1990. Accessed Jan. 19 2010

[http://dnr.louisiana.gov/SEC/EXECDIV/TECHASMT/alternative\\_fuels/cng.htm](http://dnr.louisiana.gov/SEC/EXECDIV/TECHASMT/alternative_fuels/cng.htm)

American Public Transportation Association. "The Benefits of Transportation – Relieving Traffic Congestion" 2009. Accessed Jan. 19 2010

<http://www.apta.com/resources/reportsandpublications/Documents/congestion.pdf>

East Asia Society for Transportation Studies. "2005. Accessed Jan. 19 2010.

[http://www.easts.info/on-line/proceedings\\_05/2195.pdf](http://www.easts.info/on-line/proceedings_05/2195.pdf)

How Stuff Works. "If diesel engines are more efficient, why do most cars have gasoline engines?" Accessed on Jan. 21 2010 <http://auto.howstuffworks.com/question399.htm>



## **Mixed-use Community**

Creating a mixed-use downtown encourages positive social interaction amongst the community by providing vicinities that can be used by most members.

### ***Description***

Building a neighborhood with a multitude of commercial and residential areas on walkable streets promotes a sense of community. Also, by providing a diverse downtown region, automotive traffic should decline due to the close proximity of essential buildings and readily available public transit. A thriving mixed-use community generally includes a variety of housing opportunities, easily accessible public transit, cooperate offices, retail shops, and open public spaces.

Housing types need to include all different types, in order to meet the diverse needs of the population. Single room occupancy units, townhouses, and condominiums should all be considered for construction.

Zoning laws might need to be revised due to the assorted uses of nearby land. Incentives, such as tax credits, tax breaks, and real estate credits could be offered to entice investors, businesses, and residents. Providing developers with density bonuses will encourage downtown mixed-use development.

### ***Costs and Benefits***

Overall price varies significantly.

- ✓ Builds a sense of community to lower crime rates
- ✓ Reduces automotive traffic which contributes to environmental well-being

- ✓ Provides an encouraging environment for interaction
- ✓ Contributes to the desired economic development of the town
- ✓ Allows for community green space
- ✓ Creates development flexibility with multi-function areas.
- ✓ Encourages diversity through design standards.

## ***Evidence***

The Urban Land Institute and the Center for Transit-Oriented Development studied traffic flow in four urban regions across the US with mixed-use vicinities. In peak travel periods, approximately 49 percent fewer vehicles trips were made during the morning, afternoon, and evening rush hours.

In 2003, Browning and Cagney found that a psychological sense of community is crucial to promoting individual and societal well-being. Supportive neighborhoods can mediate and moderate community-level socioeconomic disadvantages and related health problems.

Statistical data found by John Crompton, Parks & Recreation in 2001 proves that the construction or renovation of a park will assist in attracting future businesses and desirable residents.

## ***Sources***

Project for Public Spaces. "Creating a Place" 2009. Accessed Jan. 19 2010.

[http://www.pps.org/mixed\\_use/info/mixed\\_use\\_approach](http://www.pps.org/mixed_use/info/mixed_use_approach)

Thomas Jefferson Planning District Commission. "Mixed Use Communities, Housing Action Agenda" 2009. Accessed Jan. 19 2010.

[http://www.tjpd.org/pdf/mixedUse\\_agenda.pdf](http://www.tjpd.org/pdf/mixedUse_agenda.pdf)

Philip Langdon. "Studies: Mixed-use, Walkable Development Alleviates Traffic" 2008. Accessed Jan. 19 2010.

<http://www.newurbannews.com/13.6/sep08studies.html>

The Australian Psychological Society. "Psychological sense of community & its relevance to well-being & everyday life in Australia" 2006. Accessed Jan.19 2010

<http://www.groups.psychology.org.au/Assets/Files/Community-Updated-Sept061.pdf>

John L. Crompton. "The Impacts of Parks on Property Values – Statistical Data Included" 2001. Accessed Jan. 19 2010.

## **Geothermal Power**

Geothermal Power involves using the heat of the earth's center to power generators. By harnessing geothermal power plant technologies, Kingston would be able to provide sustainable energy to its community.

### ***Technical Description***

This natural form of energy production that begins with deep holes drilled into the ground to find a geothermal hot spot. A pipe is then placed in the hole to allow the heat to rise to the surface. The compressed steam is directed into a turbine which is connected to a generator. Steam turns the turbine, and the turbine turns the generator. A new pipe is put into the earth to pump in cold water. The earth heats the new water which produces more steam to continue the process.

A suitable site for geothermal power must have the extreme heat of the earth's mantle as close to the surface as possible. Volcanoes or geysers indicate areas where the earth's heat is being released to the surface and near these sites are generally more likely to be viable for geothermal power. Extensive geological surveying is needed to determine the suitability of a site for geothermal power, due to the variable nature of the earth's crust.

### ***Costs and Benefits***

Approximate cost is US \$3400/kW, with much of cost being construction. Cost of operation comparable to natural gas ~\$90/MW

- ✓ Geothermal power is one of the most renewable energy sources today. During a person's lifetime, the earth will always produce heat.
- ✓ No pollution is created.
- ✓ Plants are much smaller compared to an oil, gas, coal or nuclear plant.
- ✓ No fuel is used for generating power.
- ✓ Only power needed is for water pumps, which can be self-generated.
- ✓ The cost of drilling can be 45 – 95 percent of the total plant cost.
- ✓ Blue Mountains have promising production power.
- ✓ Some gases may be release from earth, but can be easily contained.
- ✓ The rock may not be soft enough to drill.
- ✓ Sudden production of steam is unlikely, but plausible.
- ✓ Drilling can sometimes cause geological instability – careful surveying must be done to ensure safety of site

## ***Evidence***

The Government of Jamaica believes that since “a number of Latin American countries such as Costa Rica, Nicaragua, El Salvador and Guatemala have all been able to develop some of their geothermal resources”, Jamaica should be able to do the same.

Based off of a study by Claude Davis in 2002 for the Ministry of Water, energy is the number one contributor to greenhouse gas (GHG) emissions. Geothermal energy would contribute to lowering those discharges.

## **Sources**

Clean Energy Ideas. "Geothermal Power Plant" 2009. Accessed Jan. 20 2010.  
[http://www.clean-energy-ideas.com/articles/geothermal\\_power\\_plant.html](http://www.clean-energy-ideas.com/articles/geothermal_power_plant.html)

Government of Jamaica. "Geothermal Energy" 2008. Accessed Jan. 20, 2010.  
[http://www.mct.gov.jm/energy\\_7.htm](http://www.mct.gov.jm/energy_7.htm)

Beatty, Jenna; Lund, Jenny; Robertie, Calvin. "Renewable Energy Resources Best Practices Manual" Nov. 2010. Worcester Polytechnic Institute.

## **Solar Power**

Solar power technology is very applicable to Jamaica due to the intensity of the sun's rays close to the equator.

### ***Technical Description***

Solar Power can be used for electricity generation by harnessing the energy in solar radiation. There are two main ways in which electricity can be produced by solar radiation. The more well known method is photovoltaic's, which transforms the energy in the sun's rays directly into electricity. The other method which is becoming more common is harnessing the sun to heat up a liquid which can then be used to generate electricity in a generator. This is known as concentrated solar power.

### **Photovoltaic Power (PV)**

Photovoltaic electricity is generated by panes of special crystalline materials which release electrons when hit with solar radiation. This technology is being constantly improved upon, and one panel that has been developed reached an efficiency of over 40%. However, most photovoltaic cells will attain an efficiency of only 5% to 20% depending on the design of the cell and the directness of the sunlight. The more expensive panels will achieve better efficiency with a thicker and more complex cell design, and more power can also be produced by making the panel move to track the sun through some or all of the day. The cells have a low operations cost and relatively little maintenance.

## **Concentrated Solar Power (CSP)**

Concentrated solar power is an alternative method of solar power in which the sun's rays are concentrated by a series of mirrors or lenses and are used to heat up a liquid to very high temperatures (often between 400C and 1000C, depending on the type of set-up). There are a variety of arrays with different costs and benefits, but the two most common are a parabolic trough system and a dish design. In a parabolic trough system a curved mirror parallel to the ground concentrates sunlight into a tube running the length of the mirror,

A dish design consists of mirrors that are arranged to resemble a satellite dish and concentrate sunlight onto a point in front of the dish. The parabolic trough method is usually used to produce steam power by traditional steam generators and so it is adaptable to current infrastructure. The dish method is more versatile in size since the dishes operate independently and each produces power through an individual generator and feeds it to the grid.

### ***Costs and Benefits***

PV costs usually cost about US\$0.06 – US\$0.17 per kW of power depending on the type of panel. Capital costs are around US\$3,300 per kW to install.

CSP systems cost around US\$0.12 per kW, and capital costs can be from US\$2 million to US\$5 million per MW depending on the scale and style of the system.

- ✓ PV is inexpensive to install and operate and requires little maintenance.
- ✓ PV has relatively low efficiency and requires a large amount of land to place an effective array.
- ✓ CSP is a more efficient method, gaining efficiencies of 20% to 40% and is an advancing technology that is getting cheaper constantly. CSP also requires a large amount of land area to place an array.



- ✓ CSP parabolic troughs can be retrofitted to existing steam generators which can potentially reduce cost. Dish style arrays can be made a smaller scale and tend to be less expensive.
- ✓ Any interruption in sunlight hurts the efficiency of the system, so the Jamaican rainy season could significantly impact the effectiveness of a solar power system.

## ***Evidence***

CSP technology is being heavily researched right now and more efficient systems are being developed. The higher efficiency of these systems will produce more power from the same amount of sunlight, so less total land area will be needed to achieve the same potential power.

PV technology is an “old” technology compared to CSP so the components tend to be cheaper and more reliable. However, PV systems are often not worth the costs unless the location is guaranteed to have intense sunlight that is seldom interrupted.

## ***Sources***

Beatty, Jenna; Lund, Jenny; Robertie, Calvin. “Renewable Energy Resources Best Practices Manual” Nov. 2010. Worcester Polytechnic Institute.

Headley, Oliver. “Renewable Energy Technologies in the Caribbean” 1997. Accessed Jan. 20, 2009. Available at <http://www.sciencedirect.com>

Konrad, Tom. “They do it with Mirrors: Concentrating Solar Power” Dec. 2006. Accessed Jan. 20, 2009. <http://cleanenergywonk.com/2006/12/07/they-do-it-with-mirrors-concentrating-solar-power/>

Hutchinson, Alex. "Solar Thermal Power May Make Sun-Powered Grid a Reality" Nov. 2008. Accessed Jan. 20, 2009.

<http://www.popularmechanics.com/science/research/4288743.html?page=1>

## **Wind Power**

The use of off-shore and on-shore wind turbines to generate electric power is sustainable, efficient, and produces clean energy under the right wind conditions.

### ***Technical Description***

Wind power can be broken down into two categories; off-shore turbines and on-shore turbines. The turbine technology used in these two applications is the same, with the main difference coming in the structural aspect of the turbine towers and the transmission of power. Wind turbines need a fairly constant air flow at certain speeds to be efficient, thus limiting the potential locations of the turbines.

### **On-Shore**

Jamaica already has a successful on shore wind farm at Wington which has a capacity of approximately 20.7 MW at a cost of US\$26.2 million. Possibilities for onshore wind power include expanding and/or upgrading this wind farm or construction of a new farm at another location. Several other locations have been identified in the past as possibly being suitable for wind energy including Green Castle, Blenheim, and Spur Tree.

### **Off-Shore**

Off-shore wind farms tend to have more constant and higher average wind speed which results in greater efficiency of the turbines and more power generated. Being off-shore can have other benefits such as reduced noise pollution and space requirements.

The drawback of offshore wind generators typically is cost. Off-shore turbines require extensive foundations to ensure stability, especially in a hurricane prone area such as Jamaica. They also require transmission lines to be laid underwater which can incur greater cost than overhead or buried lines.

## ***Costs and Benefits***

On-Shore (approximation)

- Cost for power: typically US\$ 0.04 per MW.
- Capital cost: US\$ 1 million per MW capacity.

Off-shore (approximation)

- Cost for power: typically US\$ 0.095 per MW.
- Capital cost: US\$ 1.5 million to US\$ 2.5 Million per MW capacity.

- ✓ Off-shore turbines will produce more power per turbine, but at greater cost
- ✓ Wind power is clean and renewable energy that can help reduce Jamaica's reliance on imported fuel.
- ✓ Large amounts of capital will be needed to complete any project that will be able to provide significant amounts of power to Kingston.
- ✓ The larger the farm the greater the efficiency and the lower the cost of energy.

## ***Evidence***

In 2004, approximately 12 percent of Jamaica's GDP was devoted to importing resources. About 90 percent of Jamaica's power is generated by using imported fuels.

The cost of energy is greatly affected by wind speed and consistency: in one study an average speed of 7.15 m/s resulted in a price of 4.8 cents per MW and a speed of 9.32 m/s cost only 2.6 cents per MW. Energy produced on a 51 MW farm cost approximately 40 percent less than energy produced on a 3 MW farm.

## **Sources**

Beatty, Jenna; Lund, Jenny; Robertie, Calvin. "Renewable Energy Resources Best Practices Manual" Nov. 2010. Worcester Polytechnic Institute.

Wigton Windfarm Ltd. "Wigton Windfarm Project" 2006. Accessed Jan.19 2010.  
[http://www.pcj.com/wigton\\_windfarm\\_project.htm](http://www.pcj.com/wigton_windfarm_project.htm)

Jackson, Dr. Gary. "Jamaica's Wind Energy and Development" April 2009. Accessed Jan.19 2010.  
<http://arpel.clk.com.uy/ppt/VIERNES%2024/Mesa%20redonda%205/Jackson.pdf>

Ministry of Energy, Mining, and Telecommunications. "Energy Division" Government of Jamaica. 2004. Accessed Jan.19 2010.  
[http://www.mct.gov.jm/new\\_energy\\_division\\_1.htm](http://www.mct.gov.jm/new_energy_division_1.htm)

American Wind Energy Association "The Economics of Wind Energy" Feb. 2005. Accessed Jan.19 2010. <http://www.awea.org/pubs/factsheets/EconomicsOfWind-Feb2005.pdf>

## **District Cooling**

District cooling is an energy and cost efficient way of cooling multiple buildings within a confined area, using one source of chilled water which is distributed to all the buildings.

### ***Technical Description***

District cooling can be achieved in a number of ways, each having varying efficiency and cost. However, most cases result in large energy savings since buildings are not running individual cooling systems. In addition to the energy savings, district cooling systems frees each building from needing to house the mechanical equipment associated with a central air conditioning system, which saves both space and money spent on operations and maintenance.

Although many systems of this type attain their chilled water from a lake or ocean, it is most likely that the Caribbean ocean would not provide sufficient cooling power to make the system efficient. One alternative is to use deep well water as a cooling source, but if this is not viable another alternative would be to use cooling towers which reject heat into the atmosphere. Many systems used today in warmer climates use absorption chillers to cool the water. An absorption chiller has the same effect as a normal compressor run refrigeration system but operates on heat rather than electricity for its main source of cooling power. This allows such systems to benefit from waste heat of machinery or industrial processes.

There are a number of ways to make these systems more efficient, which will in most cases pay for themselves within a year. One cost effective method of optimization involves prioritizing chillers in accordance with load. The system starts with only the number of chillers needed to meet demand, and when the demand on the system passes a certain percentage, an additional chiller will kick on to meet demand, and so

forth. Other options that save energy include an ice or cool water storage system, where during off hours the system uses minimal resources to chill a tank of water or salt water, which can then be fed into the system during peak hours to meet demand without overloading the chillers.

## ***Costs and Benefits***

Costs of systems vary greatly, with further investigation required to give an accurate estimate of price. Generally capital costs of installing such a system can be large, but operations costs can be reduced through optimization of the system, and use of waste heat

- ✓ Due to the warmth of the Caribbean seas, ocean source cooling will likely not be viable, potentially increasing cost
- ✓ District cooling is most efficient in areas of very high demand, and Kingston seems to have a high downtown demand for cooling
- ✓ Energy costs can be significantly reduced by use of either waste heat from other processes, or heat generation from waste incineration (possibly leading to cogeneration of electricity).
- ✓ Thermal storage systems such as ice storage can increase capacity and efficiency of the system

## ***Evidence***

Ocean cooled systems typically need an environment with cold winters to reduce the temperature of the water. Most systems need water consistently cooler than 20C to 24C

at a maximum, where the Caribbean may regularly be 30C or warmer in the summer months.

District cooling is efficient because it gains the energy freed by the shutdown of individual air conditioning systems in the area being serviced. For the system to be truly effective as much should be done as possible to optimize the system by making use of wasted heat end energy from other systems in order to see a return within the life time of the system. It should also be ensured that all individual cooling systems are eliminated from the area being serviced, since if the chilled water is not being used the energy used to chill the water will be wasted.

Costs include a feasibility study, the construction for facility, purchasing large scale chillers, laying the cool water distribution pipes, and hookups to the pipe network for each building. Large amounts of pumping power may also be needed to get a reasonable rate of flow through the buildings.

A case study of a district cooling plant in Hong Kong found that having 40% ice storage capability was the most efficient in terms of energy use, and that having the next chiller start up when the chiller before it in sequence reaches between 75% and 80% of its capacity.

## **Sources**

Chow, T.T.; Au W.H.; et all. "Applying district-cooling technology in Hong Kong" Jan. 2004. Accessed Jan. 19, 2009. Available at <http://www.sciencedirect.com>

Headley, Oliver. "Renewable Energy Technologies in the Caribbean" 1997. Accessed Jan. 20, 2009. Available at <http://www.sciencedirect.com>

Chow, T.T.; Chan, L.S.; et all. "Performance evaluation of district cooling plant with ice storage" July 2005. Accessed Jan. 20, 2009. Available at <http://www.sciencedirect.com>



Wang, Fulin; Yoshida, Harunori; Ono, Eikichi. "Methodology for optimizing the operation of heating/cooling plants with multi-heat-source equipments" July 2008. Accessed Jan. 19, 2009. Available at <http://www.sciencedirect.com>

Shimoda, Yoshiyuki; Nagota, Tomoji; et al. "Verification of energy efficiency of district heating and cooling system by simulation considering design and operation parameters" Nov. 2005. Accessed Jan. 19, 2009. Available at <http://www.sciencedirect.com>

Werner, Sven. "District Heating and Cooling" 2004. Accessed Jan. 20, 2009. Available at <http://www.sciencedirect.com>

## **Green Roofs**

Green roofs are simply rooftop gardens which aim to cover as much of the roof as possible with foliage for aesthetics, storm water management, reduction of the heat island effect, and thermal insulation.

### ***Technical Description***

Green roofs vary in size, thickness of the growing medium, and types of plants supported. Green roofs can be broken down into three general categories: extensive, intensive, and Semi-intensive. Extensive roofs tend to have a small amount of growing medium – 4 to 8 inches at most – and support mostly grasses, small shrubs, and other lightweight plants with small root systems. Intensive roofs can have a much larger amount of growing medium and can support most kinds of plants up to small trees. This is the type that is generally used as a rooftop garden with paths and places to sit, where the extensive roof is generally accessed only for maintenance. Intensive roofs can be quite heavy, and sometimes require their own support structure to carry the load of the growing medium and plants (and people) to the building frame. Semi-intensive roofs are anything in between, which may support large bushes and very small trees, and may or may not be accessible to the public.

For the downtown revitalization of Jamaica, the most important aspect for the green roof will likely be its insulating properties. Green roofs have been shown in many studies to provide benefits beyond simple insulation. The advantage of living plants as opposed to a regular insulated roof is that the plants reflect and absorb most of the solar radiation that hits them, preventing heat from reaching the roof. On a traditional roof the solar radiation can make the roof and the air above it extremely hot, sometimes in excess of 60C to 70C, where a green roof may experience temperatures in the mid to high 30s. This has significant implications for the cooling of the building. One study

found that having a green roof resulted in the heat flow through the roof being reduced by 75%, which would result in significant energy savings. All studies agree that the thermal properties of green roofs are most beneficial in urban environments, and in regions with warm and hot climates.

The heat island effect occurs in dense urban areas, where the ambient air temperature becomes significantly higher than elsewhere in the region due to the amount of heat absorbing surfaces such as pavement. Utilizing green roofs has been shown to reduce the air temperature locally, and if they are used frequently throughout the urban environment, the heat island effect can be mitigated to some extent.

Green roofs can provide good storm water management by absorbing a lot of the rainwater before it has a chance to become runoff. Widespread use of green roofs can relieve a large amount of the load on water treatment facilities, and can reduce the peak intensity of storm water flow during a storm.

The aspect of aesthetic appeal should not be overlooked, especially for a city which has much to gain by improving its tourism appeal. Extensive green roofs can become gardens or parks in themselves and can be attractive to visitors, even to the point of becoming an attraction.

### ***Costs and Benefits***

Green roofs are more expensive than a traditional roof, with the price varying greatly depending on the type of roof, and the location. It is difficult to come up with a reasonable average price range for Kingston, but a rule of thumb used in a number of studies is that a green roof costs about two to three times what a normal roof costs.

- ✓ Green roof production benefits from economies of scale, so if they were implemented across all new construction in Kingston costs could likely be brought down to a reasonable range compared to normal roofing

- ✓ During dry weather green roofs will need to be watered, although the extensive style roofs tend to be hardier. Regular maintenance is required for any green roof
- ✓ Green roofs can provide significant energy savings for cooling large buildings
- ✓ Green roofs can reduce the urban heat island effect, reducing the air temperature of the entire downtown area
- ✓ Extensive green roofs can double as parks and gardens, and can serve as attractions to visitors or tourists.
- ✓ Green roofs also provide significant storm water management benefits during the rainy season

## ***Evidence***

An average of several studies estimates the reduction in cooling costs due to green roofs to be about 15% - actual savings would likely be less, but still significant.

A number of sources have tried to price green roofs in \$ per square foot:

- Standard roof \$9 – green roof (intensive \$24, semi intensive \$18, extensive \$12)
- Standard roof \$4.57 – green roof (intensive \$8.35, extensive \$8.97)
  - Making the rooftop accessible doubled the price in this study
- Green roof in the US - \$15 to \$25

## ***Sources***

Banting, Dr Doug.; Doshi, Prof Hitesh.; et all. “Report on the Environmental Benefits and Costs of Green Roof Technology for the City of Toronto” Oct. 2005. Accessed on Jan. 20, 2010. <http://www.toronto.ca/greenroofs/pdf/fullreport103105.pdf>

Greenroofs.com “Green Roof FAQs” 2007. Accessed on Jan. 20, 2010.

<http://www.greenroofs.com/Greenroofs101/faqs.htm>

Wong, Nyuk Hien; Tay, Su Fen; et all. “Life cycle cost analysis of rooftop gardens in Singapore” April 2002. Accessed on Jan. 16, 2010. Accessible on

[www.sciencedirect.com](http://www.sciencedirect.com)

Kumar, Rakesh; Kaushik, S.C. “Performance evaluation of green roof and shading for thermal protection of buildings” July, 2003. Accessed on Jan. 16, 2010. Accessible on

[www.sciencedirect.com](http://www.sciencedirect.com)

Liu, K.; Baskaran, B. “Thermal performance of green roofs through field evaluation”

May, 2003. Accessed on Jan. 16, 2010. Accessible on [www.sciencedirect.com](http://www.sciencedirect.com)

Liu, K.; Minor, J. “Performance evaluation of an extensive green roof” May, 2005.

Accessed on Jan. 16, 2010. Accessible on [www.sciencedirect.com](http://www.sciencedirect.com)

Lazzarin, Renato M.; Castellotti, Francesco; Busato, Filippo. “Experimental measurements and numerical modeling of a green roof” Nov. 2004. Accessed on Jan.

19, 2010. Accessible on [www.sciencedirect.com](http://www.sciencedirect.com)

## **Hydrothermal Potential**

Water power may be a viable option. Jamaica has already installed a number of hydropower plants and has identified possible sites for more. Only one seems to have potential to produce significant power: the Back Rio Grande site. The idea of hydropower does not need to be presented, but perhaps Stantec would be able to incorporate a hydropower plant into the downtown revitalization plan, possibly to provide power for new systems to be installed as part of this plan, such as a district cooling system.

## **Waste Management**

In regards to waste management, the most important considerations for Kingston, Jamaica are more efficient collection systems and more material reuse and recovery.

### ***Technical Description***

There are many different methodologies available for waste management systems but most share a number of common traits. The main idea of such a methodology is to minimize the amount of waste that makes it to the landfill, and maximize the amount that can be reused for various purposes. The first stage in any waste management program should be an efficient collection system. Curbside and dumpster pickup is usually the best option, but if this is not feasible easy access should be provided to the collection facility or landfill site. Efforts should be made to sort the trash as much as possible before delivery to the landfill or collection facility, to facilitate the separation process. Waste can be separated into several groupings depending on the intended use. Incineration plants can make use of a large percentage of waste. Organic waste should be composted as much as possible. A good rule to follow that most countries have adopted in one form or another is the philosophy of “Prevention and minimization, then materials recovery, then incineration, and finally landfill”

Incineration for heat and energy is a common technology being used in many countries around the world. It has the double benefit of providing a source of potential energy for the community in which the incinerator is located, and it can reduce the volume of garbage to ash which typically weighs about one fifth as much as the waste fuel. Incineration waste to energy systems harness the heat of the burning waste to power generators, and can produce a significant amount of power. This heat can also be used to heat homes, or in the case of the downtown revitalization, to power

absorption chillers for a cooling system. In general, around 80% of non-recyclable waste collected will be able to fuel the incinerator, where the other 20% must be dumped.

Landfill gas recovery systems are another effective option for generating power from waste. These types of plants generally have lower operating costs than incinerators, although they do not manage the volume of waste at all. These plants collect the methane gas generated by the rotting waste, and either concentrate it into fuel, or burn it on site to produce heat and power. Though these plants are efficient, they have the limitation of only being effective while the landfill is active, and for a limited time after it closes (usually 5 or so years). Over time a closed landfill will produce less and less methane, eventually making the plant non functional.

### ***Costs and Benefits***

Typical costs of an incineration waste to energy system is about US\$110,000 to US\$140,000 per daily ton of waste managed in capital costs, and around US\$0.04 per kW of energy

A typical landfill gas system installed on a ten meter deep landfill costs from US\$40,000 to US\$90,000 to install, and if used to directly generate electricity costs around US\$ 1500 to US\$2500 per kW produced in capital costs, depending on the size and efficiency of the system. Electricity will cost on average about US\$0.04 per kW of energy.

- ✓ A typical incineration system will produce around 500kW of power for every ton of waste. (the larger the system, the greater the efficiency)
- ✓ Landfill gas systems are efficient and can produce a significant amount of fuel and prevent greenhouse gas from reaching the atmosphere.
- ✓ Better waste management practices improve the aesthetic appeal of an area or city. It will reduce the amount of visible trash and unpleasant odors.



## **Evidence**

Jamaica has very little material recovery for its waste, with the majority being put into landfills. Energy from waste programs help reduce the volume of waste in landfills, and could help provide power to the grid.

Waste to energy programs work most efficiently near urban areas since cities both produce the most waste and demand the most power.

## **Sources**

Baud, Isa; Grafakos, Stelios; et all. "Quality of Life and Alliances in Solid Waste Management" 2001. Accessed Jan. 21 2010. Available at [www.sciencedirect.com](http://www.sciencedirect.com)

Beatty, Jenna; Lund, Jenny; Robertie, Calvin. "Renewable Energy Resources Best Practices Manual" Nov. 2010. Worcester Polytechnic Institute.

Fiorucci, Paolo; Minciardi, Riccardo; et all. "Solid waste management in urban areas Development and application of a decision support system" July 2001. Accessed Jan. 21 2010. Available at [www.sciencedirect.com](http://www.sciencedirect.com)

Longden, David; Brammer, John; et all. "Distributed or centralized energy-from-waste policy? Implications of technology and scale at municipal level" June 2006. Accessed Jan. 21 2010. Available at [www.sciencedirect.com](http://www.sciencedirect.com)

Srinivas, Hari. "An Urban Waste Management Continuum" Accessed Jan. 21 2010. <http://www.gdrc.org/uem/waste/continuum/continuum.html>

The Caribbean Environmental Health Institute. "Experts Meeting on Environmentally Sound Technologies for Waste Management in Caribbean SIDS" Dec. 2003. Accessed Jan. 21 2010. [www.unep.org/depi/PDF/Experts%20Meeting%20-%20final%20report.doc](http://www.unep.org/depi/PDF/Experts%20Meeting%20-%20final%20report.doc)

## **Rainwater Harvesting**

Due to the amount of rainfall in Kingston and the flexibility of design rainwater harvesting could be an attractive way for Kingston to reduce its potable water demand.

### ***Description***

Rainwater harvesting is the process of collecting rainwater and using it for applications such as irrigation or toilet flushing. By using rainwater for non-potable needs, potable water can be conserved. For example, by collecting 1" of rain over 1 sq ft, 0.623 gallons of rainwater can be collected, therefore saving 0.623 gallons of potable water. Typically rainwater is captured using gutters that redirect the rainwater into a storage tank. These tanks often will have a "first flush" system that filters the debris out of the rainwater to ensure its quality.

### ***Cost/Benefits***

Estimated cost highly variable depending of type of system used and the maintenance costs for the tank.

- ✓ The quality of water collected using rainwater harvesting must be monitored to ensure the water is of acceptable quality.
- ✓ Since rainwater is not generated constantly steps must be taken to prevent overflow.
- ✓ Reduce storm water runoff and reduces strain on drainage systems.
- ✓ Provides backup water in case of drought.
- ✓ Can be used to irrigate plants that might otherwise not receive enough water.

- ✓ Can be used to help groundwater recharge.
- ✓ Reduce monthly water bills (reductions depend of size of the catchment area and storage tank).
- ✓ Simple technology with minimal upkeep.
- ✓ Provides backup water in case of drought.
- ✓ Customizable to fit user needs.

### ***Supporting Evidence***

A case study conducted in 2000 in the UK on a rainwater harvesting system associated with a supermarket was able to use grey water for 20% of the building needs. This was despite only using half the buildings roof to gather rain water. The study also cited an oversized tank for the used collection space as a reason for a payback period of 12 years. By designing a more efficient system the study speculated that the payback period could be reduced.

A 2006 study in Southern Brazil found that two houses reduced potable water usage by approximately 35% each if rainwater harvesting practices. However, the payback period of the system was very high (above 17 years).

### ***Sources***

Cross, Hugh and Duncan, Kim. "RAINWATER TANKS." Hunter Central Coast Regional Environmental Management Strategy. 2007. Accessed 1/19/2010.

[http://www.huntercouncils.com.au/environment/products/downloads/water/Practice\\_Notes/No4\\_Rainwater%20tanks.pdf](http://www.huntercouncils.com.au/environment/products/downloads/water/Practice_Notes/No4_Rainwater%20tanks.pdf)

“Rainwater Harvesting.” Innovative Water Solutions. 501 W. Powell Ln. #202, Austin, Texas 78753. Copyright 2010. accessed 1/19/2010.

<http://www.watercache.com/education/rainwater/>

“Rainwater Harvesting.” ToolBase Services, c/o NAHB Research Center, 400 Prince George’s Blvd., Upper Marlboro, MD 20774. 2008. Accessed 1/19/2010.

<http://www.toolbase.org/Techinventory/TechDetails.aspx?ContentDetailID=918&BucketID=6&CategoryID=11>

Chilton, J.C et al. “Case study of a rainwater recovery system in a commercial building with a large roof.” Science Direct, The University of Nottingham, Nottingham, UK, South Bank University, London, UK, Safeway Stores PLC, Middlesex, UK, and Gerald Tobias Associates, West Sussex UK. April 12<sup>th</sup>, 2000. Copyright © 2000 Elsevier Science Ltd. Accessed 1/20/2010.

[http://www.sciencedirect.com/science?\\_ob=ArticleURL&\\_udi=B6VR2-41KPCJV-9&\\_user=74021&\\_rdoc=1&\\_fmt=&\\_orig=search&\\_sort=d&\\_docanchor=&\\_view=c&\\_searchStrId=1174156887&\\_rerunOrigin=scholar.google&\\_acct=C000005878&\\_version=1&\\_urlVersion=0&\\_userid=74021&\\_md5=1780cf0a7211991b7b93480ac0d16c25](http://www.sciencedirect.com/science?_ob=ArticleURL&_udi=B6VR2-41KPCJV-9&_user=74021&_rdoc=1&_fmt=&_orig=search&_sort=d&_docanchor=&_view=c&_searchStrId=1174156887&_rerunOrigin=scholar.google&_acct=C000005878&_version=1&_urlVersion=0&_userid=74021&_md5=1780cf0a7211991b7b93480ac0d16c25)

Ghisi, EneDir and Mengotti de Oliveria, Sulayre. “Potential for potable water savings by combining the use of rainwater and grey water in houses in southern Brazil.” Science Direct and Federal University of Santa Catarina, Florianopolis, Brazil. February 6<sup>th</sup> 2006. Copyright © 2006 Elsevier Ltd. Accessed 1/20/2010.

[http://www.sciencedirect.com/science?\\_ob=ArticleURL&\\_udi=B6V23-4JJGB1N-1&\\_user=74021&\\_rdoc=1&\\_fmt=&\\_orig=search&\\_sort=d&\\_docanchor=&\\_view=c&\\_searchStrId=1174275945&\\_rerunOrigin=scholar.google&\\_acct=C000005878&\\_version=1&\\_urlVersion=0&\\_userid=74021&\\_md5=dd1d3f3a66f97efc90cb88b5a9335b39](http://www.sciencedirect.com/science?_ob=ArticleURL&_udi=B6V23-4JJGB1N-1&_user=74021&_rdoc=1&_fmt=&_orig=search&_sort=d&_docanchor=&_view=c&_searchStrId=1174275945&_rerunOrigin=scholar.google&_acct=C000005878&_version=1&_urlVersion=0&_userid=74021&_md5=dd1d3f3a66f97efc90cb88b5a9335b39)

## **Grey Water Reuse**

Grey water reuse systems may provide an economical way for Kinston to reduce its potable water demand by reusing water from applications such as showers or washbasins for uses that do not require potable water quality.

### ***Description***

Reuse of grey water consists of using water already used by showers, laundry machines, and sinks for other applications such as toilet flushing or irrigation. This practice conserves potable water. Between collection and use of grey water often the water is subjected to some type of treatment. This treatment varies depending on the original water quality and the intended use of the grey water.

### ***Costs/Benefits***

Basic domestic system cites to costs US \$5,000. The initial, operation, and maintenance costs vary depending on type and extent of system.

- ✓ Can be energy inefficient compared to potable water.
- ✓ Must properly analyze site in order to install suitable system.
- ✓ If proper precautions are not taken can pose health risk.
- ✓ The buildup of pollutants may harm plant life that is watered using.
- ✓ Smell of grey water needs to be addressed.
- ✓ User may not maintain system properly leading to failure.
- ✓ Conserve potable water by using grey water instead.

- ✓ Can be used to irrigate plants that might otherwise not receive enough water.
- ✓ Can be used to help ground water recharge
- ✓ Can lower water bills if correct system is installed.
- ✓ Reduce strain on water sewage treatment plants.

## ***Evidence***

A 2003 case study in Spain on a hotel Spain that used grey water filtered through a nylon sock and disinfected with sodium hypochlorite to flush toilets was able to reduce potable water usage by 23%.

A 1995 study in Australia found that among 5 sites implementing experimental grey water systems reduced potable water usage between 12% and 28%.

A study conducted in 2000 in the United Kingdom that implemented a typical UK low tech grey water recycling system consisting of a filter, storage tank, and disinfection tablets found that four houses reduces their potable water usage by 9%, 17%, 21%, and 36%. It should be noted however that the reliability of these systems was poor and that the results were skewed for some of the households due to systems malfunctions.

The economics of a grey water system are highly dependant on the cost and availability of the local water. A 2005 study in Israel found that was examining the cost feasibility of a rotating biological contactor grey water system found that a 7 story building was required to make the system economically feasible using water rates in Israel. However, if the cost of water in the United States was used the required size the building grew to 19 stories, and the required building size in Germany was 4 stories.

A 2008 study in Jordan that implemented simple low tech grey water schemes among 110 rural low income households was able to reduce household water usage by 237 liters/day per household with a B/C ration of 2.7/1

## Sources

Friedler, E, and Hadari, M. "Economic feasibility of on-site grey water reuse in multi-storey buildings." Science Direct and the Division of Environmental, Water and Agricultural Engineering, Faculty of Civil and Environmental Engineering, Technion, Haifa 32000, Israel. Copyright © 2006 Elsevier B.V. Accessed 1/20/2010

[http://www.sciencedirect.com/science?\\_ob=ArticleURL&\\_udi=B6TFX-4JKPYB8-T&\\_user=74021&\\_rdoc=1&\\_fmt=&\\_orig=search&\\_sort=d&\\_docanchor=&\\_view=c&\\_searchStrId=1174035418&\\_rerunOrigin=scholar.google&\\_acct=C000005878&\\_version=1&\\_urlVersion=0&\\_userid=74021&md5=823bbc60d6c953165d3bcc9dbd91075e](http://www.sciencedirect.com/science?_ob=ArticleURL&_udi=B6TFX-4JKPYB8-T&_user=74021&_rdoc=1&_fmt=&_orig=search&_sort=d&_docanchor=&_view=c&_searchStrId=1174035418&_rerunOrigin=scholar.google&_acct=C000005878&_version=1&_urlVersion=0&_userid=74021&md5=823bbc60d6c953165d3bcc9dbd91075e)

Christov, Lechte, and Shipton. "Installation and Evaluation of Domestic Grey Water Reuse Systems." Victoria University of Technology. Victoria, Australia. July 1995. Accessed 1/19/2010.

<http://www.melbournwater.com.au/content/library/wsud/installation%20and%20evaluation%20of%20domestic%20greywater%20reuse%20systems.pdf>

Gual, M, March, J.G, and Orozco, B. "Experiences on greywater re-use for toilet flushing in a hotel (Mallorca Island, Spain)." Science Direct and *University of Balearic Islands, 07122 Palma de Mallorca, Spain*. Copyright © 2004 Published by Elsevier B.V. October 27, 2003. Accessed 1/20/2010.

[http://www.sciencedirect.com/science?\\_ob=ArticleURL&\\_udi=B6TFX-4CNGS9N-4&\\_user=74021&\\_rdoc=1&\\_fmt=&\\_orig=search&\\_sort=d&\\_docanchor=&\\_view=c&\\_searchStrId=1174089471&\\_rerunOrigin=scholar.google&\\_acct=C000005878&\\_version=1&\\_urlVersion=0&\\_userid=74021&md5=458c17d6893ae70274b73fdaf977a98d](http://www.sciencedirect.com/science?_ob=ArticleURL&_udi=B6TFX-4CNGS9N-4&_user=74021&_rdoc=1&_fmt=&_orig=search&_sort=d&_docanchor=&_view=c&_searchStrId=1174089471&_rerunOrigin=scholar.google&_acct=C000005878&_version=1&_urlVersion=0&_userid=74021&md5=458c17d6893ae70274b73fdaf977a98d)

Birks, Rebecca et al. "Assessment of water savings from single house domestic greywater recycling. Thames Water Research and Technology, Reading, UK and Cranfield University School of Water Sciences, Cranfield, UK.

[http://paginas.fe.up.pt/~mjneves/publicacoes\\_files/data/es/ponencias/por\\_autor/pdf/10026.pdf](http://paginas.fe.up.pt/~mjneves/publicacoes_files/data/es/ponencias/por_autor/pdf/10026.pdf)



Bino , Murad et al. "Greywater Treatment and Use for Poverty Reduction in Jordan (Phase II)." The International Research Development Centre. January 16<sup>th</sup>, 2008.

Accessed 1/19/2010. <https://idl->

[bnc.idrc.ca/dspace/bitstream/123456789/36833/1/127770.pdf](https://idl-bnc.idrc.ca/dspace/bitstream/123456789/36833/1/127770.pdf)

## **Air Handler Condensate Recovery**

Condensate captured from the coils of air conditioning units can be captured and provide cool relatively clean water suitable for a variety of uses.

### ***Technical Description***

All cooling systems rely on coils which evaporate cool water into cool air. This process cools the warm coils, which are warm due to hot and humid external conditions. As air blowing past the coils cools air moisture is formed into condensate on the coils. This condensed air forms very pure water which drips off of the coils and drains to a sewer system. Buildings with large cooling systems, especially those in humid and warm areas, have the potential of creating large amounts of cool and relatively clean water. Recovery systems can be incorporated to capture this water for reuse. Typical uses of the captured condensate include cooling tower make-up, irrigation, and other non-potable building uses such as toilet flushing.

When the condensate is used to replace evaporative losses from a cooling-tower the costs are significantly lower than when it is used for irrigation since irrigation requires storage tanks and additional water transport systems.

Although the condensate is usually pure there is risk of contamination through bacteria build-up in pipes and storage tanks. In such cases common water treatment chemicals are used to treat the condensate. This can have a detrimental effect on plants if the condensate is used for irrigation. The potential of employing UV treatment should be investigated to eliminate this risk.

Air handler condensate recovery can dramatically decrease the demand for potable water. These systems work best in areas that are exposed to high cooling loads. Shopping centers are especially applicable since condensate recovery is maximized due to a high degree of air exchange.

Air handler condensate recovery systems can become part of the package of pre-implemented incentives for potential companies relocating to Kingston. These systems are environmentally friendly and can help companies save money. Therefore implementing air handler condensate recovery systems can play a major role in representing Kingston as an innovative and sustainable community and help attract foreign investment at the same time.

### ***Cost/Benefits***

- ✓ Air handler condensate recovery systems vary greatly depending on the use of the captured water and the size of storage tanks needed.
- ✓ Costs can be reduced by not using the condensate for irrigation.
- ✓ Recovery systems have been found to range from \$US 5,000 to over \$US 30,000.
- ✓ These systems create some potential for water contamination.
- ✓ Recovering condensate from air conditioners conserves water.
- ✓ Implementing air handler condensate recovery systems will represent Kingston as a more sustainable city and a model for the entire island.
- ✓ Potential move-in companies could be seen as environmentally-responsible and save them money.

### ***Evidence***

**Table 25: San Antonio River Center Mall**

Collection Potential	12,000,000 gallons/year
Total Cost	\$32,058.00
Financial Water and Sewage Savings	\$49,500/year
Simple Payback period	8 months

**Table 26: San Antonio HEB Grocery Distribution Center**

Collection Potential	6,200,00 gallons/year
Total Cost	\$19,000.00
Financial Water and Sewage Savings	\$20,600/year
Simple Payback period	11 months

**Table 27: Houston, Texas EPA's Environmental Services Branch Laboratory**

Collection Potential	831,600 gallons/year
Total Cost	\$6,000
Financial Water and Sewage Savings	\$20,000 over 6 years
Simple Payback period	NA

## **Sources**

“NWC Meeting the Challenges” Accessed Jan. 20, 2010. <http://www.nwcjamaica.com>

“NWC Water Costs and Conservation” Accessed Jan. 20, 2010.  
<http://www.nwcjamaica.com>

Wilson, Alex; Navaro, Rachel. “Alternative Water Sources: Supply-Side Solutions for Green Buildings” May 1, 2008. Accessed Jan. 20, 2010. Available at  
<http://www.buildinggreen.com/auth/article.cfm/ID/3903/>

Weynard, Phil. “Condensate-Free Water” October 9, 2009. Accessed Jan. 20, 2010.  
Available at <http://www.watersmartinnovations.com/2009/PDFs/F-1014.pdf>

## **Water-Efficient Plumbing Fixtures**

Implementing conservation modifications to the plumbing fixtures and/or water supply systems within a building can significantly decrease the demand of both potable and non-potable water.

### ***Technical Description***

The use of alternative plumbing fixtures such as faucet aerators, pressure reducing valves, and low-flush toilets as well as toilet displacement devices, provide the same function while reducing the amount of water used. Faucet aerators break the constant flow of water into small droplets. By using entrained air in addition to the fine droplets the faucet is able to deliver the same wetting effectiveness while considerably using less water. Pressure reducing valves directly alter the flow rate of certain fixtures throughout a building. Reducing the water pressure reduces constant flow rates through fixtures and saves water. Low-flush toilets are designed to use about 1.6 gallons of water per flush compared to standard toilets which can use from 3.5 to 5 gallons. In addition non-toxic bricks or plastic containers such as milk jugs (filled with water or pebbles) can be placed inside a toilet tank to reduce the amount of water used per flush. All of these fixtures are available at a variety of costs.

Implementing such efficient fixtures may provide a water flow less than that which most individuals are accustomed to. While the differences are not typically drastic it can prove beneficial for all individuals to witness the disparity between the efficient and inefficient use of water. When using toilet-displacement devices one must make sure that the internal mechanisms of the toilet tank are not obstructed.

All of the modifications mentioned here work towards the efficient use of water. In places like Kingston where water is not readily accessible these implementations can relieve the area's water demand. Also, reducing the pressure within pipes can result in

less cracks and leaks. Reducing the pressure within homes can stop dripping faucets and leaking water heaters. In buildings/homes served by wells reducing pressure can also decrease the amount of energy needed to provide sufficient water.

The use of these water-efficient plumbing fixtures not only has the potential of reducing an owner's costs on water/sewer bills, but also represents a sustainable remedy to one of Kingston's limitations. This will encourage potential investors to consider Kingston and advance the UDC's goal of a complete revitalization of downtown.

### ***Cost/Benefits***

- ✓ Faucet aerators can be purchased for about \$US5.00.
- ✓ Pressure-reducing valve prices vary greatly and depending on the capacity of the unit they can cost anywhere from \$US50.00 to over \$US 1,000.
- ✓ The cost of low-flush toilets also varies depending on its design. These range from \$US 70 to \$US 1,000.
- ✓ The efficient use of water can result in a decrease of water flow which individuals may find less than optimal.
- ✓ The use of water efficient plumbing fixtures can help reduce the demand for potable and non-potable water.
- ✓ Provides a financial incentive for potential move-in companies and contributes to a sustainable reputation.

### ***Evidence***

A Medical Center in Portland, Oregon reported a total savings of \$US 19,225 per year on sewer and water bills after it installed water efficient plumbing fixtures. 348 toilets were changed from 3-4 gallons-per-flush (gpf) to 1.6 gpf and 590 faucets were

changed from 3.5-5 gallons-per-minute (gpm) to 1.5-2 gpm. The \$US 19,225 figure reflects the financial savings obtained from the water savings caused by the toilets and faucets mentioned above as well as 235,200 gallons per year of additional savings due to the installation of waterless urinals and low-flow shower heads. A breakdown of the water savings from the toilets and faucets is shown in the table below:

**Table 28: Portland, Oregon Veterans Affairs Medical Center**

Item (Number)	Average Use/Day	Water Saved/Unit or Flush	Total Savings Gallons/Year
Toilets (348)	6	2	1,085,760
Faucets (590)	3	0.7	322,140

The City of Corpus Christi has estimated that using water efficient plumbing fixtures can save 54,000 gallons of water annually, saving about \$60.00 per year for an average 3-family member home. The majority of the savings came from installing low-flush toilets which reduced water usage from about 4.5 gallons per flush to 1.6 gallons per flush, saving about 34% of water usage. Similarly, installing faucet aerators decreased the amount of water used per faucet by about 60%.

A study in Denver Colorado showed that of homes served by a pressurized system, an annual water savings of about 6% was demonstrated for homes that used pressure reduction valves.

## **Sources**

US Environmental Protection Agency. "How to Conserve Water and Use It Efficiently". Updated Jan 13, 2010. Accessed Jan. 20, 2010. Available at <http://www.epa.gov/nps/chap3.html>

Unit of Sustainable Development and Environment of the General Secretariat of the Organization of American States, "Other Water Conservation Practices" 1997.

Accessed Jan. 20, 2010 Available at

<http://www.oas.org/usde/publications/Unit/oea59e/ch31.htm>

US Department of Energy. "Case Study: Veterans Affairs Medical Center in Portland, Oregon" Last Updated July 2009. Accessed Jan. 20, 2010. Available at

[http://www1.eere.energy.gov/femp/program/waterefficiency\\_portland.html](http://www1.eere.energy.gov/femp/program/waterefficiency_portland.html)



## **Urban Gardens**

Urban gardens can be cultivated throughout Kingston in an effort to establish evidence for and promote sustainable irrigation and agricultural practices island-wide.

### ***Technical Description***

Urban gardens are often small community gardens which provide locals with basic food needs. Given available land and adequate soil conditions urban gardens are a great alternative to developments with greater environmental impacts. Specifically throughout the Kingston revitalization project this provides a great opportunity to experiment with sustainable agricultural practices. These may include the reuse of wastewater, storm water, and the implementation of drip irrigation.

The excess use of chemicals, fertilizers, and pesticides can pollute storm-water runoff and can be very harmful to eco-systems, water sources, and the local population. The careful selection of vegetation to be grown and proper agricultural and irrigation techniques can significantly reduce this risk.

Appropriate education and training of local farmers can lead to successful projects and inspire additional innovative ways of achieving self-sufficiency. Many of these benefits tend to lessen crime, creating a more pleasant and secure environment. Urban gardens are a simple tangible way of demonstrating how all members of a community can positively impact their environment while improving their own quality of life.

## ***Cost/Benefits***

- ✓ Base on location, size, and site conditions, the cost of cultivating urban gardens varies substantially. Larger urban gardens typically range from \$US 1,500 to \$US 4,000 of initial costs.
- ✓ Storm-water pollution may contaminate urban gardens.
- ✓ Urban gardens preserve green space,
- ✓ Urban gardens can reduce city heat from streets and parking lots.
- ✓ Urban gardens can help implement efficient water management techniques such as drip irrigation to consume less water.
- ✓ Urban gardens help develop a sense of community and a sense of responsibility.
- ✓ Encourages social interaction and provides the community a single and shared goal: healthy, home-grown food.
- ✓ This can lead to several income opportunities and encourage economic development.

## ***Evidence***

The Cuban Ministry of Agriculture in conjunction with Havana city's government successfully supported community gardens in almost every empty lot. They provided the city's gardeners with crucial supplies through "Seed Houses" which sold seeds, tools, worm compost, and biological control products at very low prices in addition to providing consultation services.

Havana now has more than 8,000 urban gardens in which over 30, 000 people are involved. Most gardeners donate a regular amount of produce to local daycare

centers, primary schools, and needy neighbors. Excesses are usually sold providing an important income supplement for families.

Urban gardens have transformed many empty lots and informal garbage dumps into beautiful gardens, provided food to local communities, multiplied urban biodiversity, and improved neighborhood aesthetics and health.

## **Sources**

Food and Agriculture Organization of the United Nations, "Water Use and Reuse for Urban Agriculture" Accessed Jan. 20, 2010. Available at <ftp://ftp.fao.org/docrep/FAO/011/ak003e/ak003e05.pdf>

Murphy, Catherine. "Urban Gardens Increase Food Security In Times Of Crisis: Habana, Cuba" Accessed Jan. 20, 2010. Available at [http://www.flacso.uh.cu/sitio\\_revista/num3/articulos/art\\_CMurphy13.pdf](http://www.flacso.uh.cu/sitio_revista/num3/articulos/art_CMurphy13.pdf)

American Community Garden Association. "What is a Community Garden" Accessed Jan.20, 2010. Available at <http://www.communitygarden.org/learn/>

## **Bio-Retention Areas**

Bio-retention areas are primarily used to capture and treat storm-water before it enters a water supply source.

### ***Technical Description***

Bio-retention areas such as rain gardens and vegetated swales are shallow vegetated trenches or depressions designed to mitigate the effects of land development on storm-water runoff. By creating vegetated areas which replicate pre-development conditions or eco-systems of a nearby forest floor these areas can capture, store, treat, and transport storm water run-off. These are applicable to commercial, residential, and industrial areas.

The use of bio-infiltration systems (rain gardens) can detain, treat, and infiltrate storm water runoff. Detaining the runoff reduces the demand on storm water systems which can pro-long the life of existing systems. These can also protect water quality by capturing storm water at the ground surface, allowing ultraviolet radiation, microbial activity, sedimentation, and plant-based nutrient sequestration to occur. This can remove pollutants from the storm water prior to its convergence to a water source. Bio-retention areas also allow the storm water to restore soil moisture and recharge ground water levels.

It is estimated that a bioswale is ½ to 1/3 the cost of a typical, engineered storm water system. (Center for Watershed Protection, 1998). Since bioswales are much closer to the ground surface than are storm drains this significantly reduces maintenance costs. Bio-retention areas create green space and are aesthetically pleasing – characteristics that many congested or blighted urban areas lack. When these are systematically designed and linked to parks they can increase interest in community social activities.

## ***Cost/Benefits***

- ✓ Costs are greatly varied. A 900 square foot bio-retention basin designed to treat runoff from ½ impervious acre in Fairfax County cost \$US 1,125.00 per year.
- ✓ Bio-retention basins should not be used in areas of high sediment loads or where sites are not stable.
- ✓ Depending on soil types and subsoil permeability, special considerations such as under drains and/or overflow basins might be necessary.
- ✓ Bio-retention areas can lessen storm-water runoff flow.
- ✓ Bio-retention areas improve storm-water quality.
- ✓ Bio-retention areas protect ground-water quality.
- ✓ Less expensive than common storm water systems.
- ✓ Creates attractive green space.

## ***Evidence***

Research in North Carolina carried out by NC State University shows the efficiency of several Bio-retention areas. In most cases the total phosphorous loads in the storm water were reduced by 9% – 66%. Total nitrogen was reduced by 40% - 68%. Additional data showed that copper, zinc, and fecal coliform were also reduced.

## ***Sources***

Hunt, William; Lord, William. Urban Waterways, “Bioretention Performance, Design, Construction, and Maintenance” Accessed Jan. 20, 2010. Available at <http://www.bae.ncsu.edu/stormwater/PublicationFiles/Bioretention2006.pdf>

Low Impact Development Center - Fairfax County, "Bioretention Basin Summary fact Sheet", 2005. Accessed Jan. 20, 2010. Available at [http://www.lowimpactdevelopment.org/ffxcty/1-4\\_bioswale\\_draft.pdf](http://www.lowimpactdevelopment.org/ffxcty/1-4_bioswale_draft.pdf)

Land Stewardship Center, "Green Communities Guide – Bioinfiltration Basins, Rain Gardens, and Bioswales". Accessed Jan. 20, 2010.

## Collecting Recyclables From Citizens

Collecting recyclables from the citizens of Kingston can help reduce the volume of waste being dumped into landfills.

### ***Description***

Due to the cost of disposing municipal solid waste (MSW) and problems with filling available landfills it is beneficial for cities to promote recycling of materials such as paper, plastic, metal, and glass. One of the simplest ways of doing this is collecting recyclables separately from garbage. This can be done by promoting citizens to separate the two and then providing two separate collection systems. This allows the municipality to then sort through the recycled material to find the material that can be sold to companies for reuse (such as plastic suitable to be melted and used in other products).

One of the main problems with collecting recyclables from citizens is citizen participation. Systems collecting recycling almost always require citizens to sort their recyclables from their garbage, and many require citizens to bring the recyclables to a different place than they would bring trash. Therefore recycling programs often with have a public education and/or outreach program executed at their inception.

There are many ways to promote increased citizen participation in recycling programs. Some strategies that have been employed are mandatory recycling programs, curbside collection, same time garbage and recycling pickup, and increased per bag garbage fees.

## ***Cost/Benefits***

Often associated with public education campaigns to increase resident participation. The scale and nature of campaign will dictate cost.

The city must provide a method of collecting recyclables (such as a drop off site). The cost of this collection service depends on the type of service and scale of the service.

The recyclable material must be brought to a sorting plant where the useable material is sorted into categories and the “residue” shipped to landfills. This facility must be constructed and sufficient workers hired to perform all the required duties.

- ✓ Must get public involved in process by sorting their recyclables.
- ✓ Citizens who place non-recyclables in the recyclable system cause unnecessary handling costs, as the waste will be transported to a landfill through a much less efficient process.
- ✓ Reduces the amount of material entering landfills.
- ✓ Conserves natural resources by recycling them.
- ✓ Citizens often feel like they are helping environment.
- ✓ Can be profitable if system is efficient enough.
- ✓ Sorting plants provide jobs.

## ***Supporting Evidence***

The government of Taiwan instituted a “Keep Trash Off the Ground” (KTOG) program in 1996 in the cities Taipei, Taichung, and Kaohsiung. This program consisted of designating the route and arrival times of garbage trucks would use during their collection runs so citizens could throw bag of trash directly into the trucks. A recyclable truck would follow the garbage truck so citizens could also throw a recyclables into it. The tons of material recycled in each of the cities were recorded for a study by the Sun Yat-Sen University published in 2007. The study performed a statistical analysis of this



data and found that the KTOG have a significant positive effect on the amount of recyclables that were collected.

A 2001 study conducted by the US Environmental Protection Agency, University of Florida, and Case Western Reserve University involving 20 metropolitan areas in the US found that introducing curbside pickup increases the proportion of households that recycle, especially glass and plastic bottles.

## **Sources**

Claire, Todd. "Technical and economic analysis of the New York city recycling system." Columbia University. May 2002.

[http://www.seas.columbia.edu/earth/wtert/sofos/Todd\\_thesis.pdf](http://www.seas.columbia.edu/earth/wtert/sofos/Todd_thesis.pdf)

Chao, Yu-Long. "Time series analysis of the effect of refuse collection on recycling: Taiwan's "Keep Trash Off the Ground" measure." Science Direct and the National Sun Yet-Sen University, 70 Lien-Hai Road, 804 Kaohsiung, Taiwan. February 12<sup>th</sup> 2007. Available at [www.sciencedirect.com](http://www.sciencedirect.com)

Jenkins, Robin et al. "The determinants of household recycling: a material-specific analysis of recycling program features and unit pricing." Science Direct, US Environmental Protection Agency, University of Florida, Case Western Reserve University. May 19<sup>th</sup> 2001. Copyright © 2003 Elsevier Science (USA) Accessed 1/21/2010. Available at [www.sciencedirect.com](http://www.sciencedirect.com)

## **Appendix C: Recreation Center Charette Preparation**

### **Clareview Recreational Center & Branch Library Sustainable Considerations**

- 1. Bioretention Areas**
2. Cogeneration
- 3. Green Roofs**
4. Low Flow Fixtures
- 5. Permeable Pavement**
- 6. Rainwater Capture**
- 7. Xeriscaping**
- 8. Solar**
9. Biomass
- 10. Ground Source Heat Pumps/ Ice Production Waste Heat**
- 11. Sustainable Construction Practices/Building Materials**
12. Air Conditioner Heat Recovery
- 13. Displacement Ventilation**
14. Pool as Heat Sink
15. Pool Water Reuse

## Bioretention Areas

- In cold climates, bioretention areas can serve as snow storage areas. Bioretention was used to treat snowmelt from three types of urban roads in Trondheim, Norway: residential, medium, and roads with high-density traffic. Bioretention boxes reduced zinc, copper, lead, and cadmium by 89–99% (Muthanna, 2007).

## Cogeneration

- More information is needed about systems already installed in the existing building and the proposed HVAC systems for the new building. Cogeneration most applicable to large scale applications – usually amount of energy used is governed by electricity demand, not heat

## Green Roofs

- Often heat conservation not as effective as heat prevention
  - Frozen soil/ growing medium is not very effective as insulation- plant cover may help somewhat
  - (Performance evaluation of an extensive green roof) Toronto study found heat loss through a normal roof was 8-9 W/m<sup>2</sup> for normal roof, and 6 – 8 W/m<sup>2</sup> for two different green roof designs
  - (Thermal Performance of green roofs through field evaluation) Ottawa – heat loss through roof reduced by 26% - from 44.1 kWh/m<sup>2</sup> for the normal roof to 32.8 kWh/m<sup>2</sup> for the green roof
  - (Design considerations for the implementation of green roofs) Vancouver – Heat flow in the winter was reduced by 40% through the roof
- Still applicable for stormwater management and air quality purposes
  - For Edmonton – green roofs are effective for reducing peak flows to help alleviate stormwater issues in periods of intense rain

- Aesthetic appeal can be greater if a more intensive system is chosen.

## Low Flow Fixtures

- Could definitely be used to reduce water usage, although more information is needed about this specific project to determine any quantified benefits

## Permeable Pavement

- According to the University of New Hampshire porous concrete may be especially effective in cold climates due to its capacity to reduce the salt needed for deicing in winter conditions. Porous asphalt has been found to work well in cold climates as the rapid drainage of the surface reduces the occurrence of freezing puddles and black ice. Melting snow and ice infiltrates directly into the pavement facilitating faster melting (Gunderson, 2008).
- A permeable pavement parking lot in Seneca College, Ontario was evaluated. Only 1 of 15 storm events resulted in surface run-off from the pervious pavement and this accounted for 10% of the total run-off volume. The pavement showed good removal of parking lot contaminants. Winter data show permeable pavement functioning well during the winter. The base course layer remained 8 degrees Celsius warmer than the air temperature on average, and continued to function as an effective storage unit even during sub-freezing temperatures. The first rainfall event after an extended cold period infiltrated well through the subsoil's (Toronto and Region Conservation, 2007).

## Rainwater Capture

- Depending on the assumptions one makes between 25,469.77 L and 39,860.11 L of water can be captured in Edmonton by a 1000 sq ft roof.
  - Based on rainfall data from Edmonton's past 30 years and assuming 75% to 90% rainfall capture it is possible to capture between 25,469.77 L and

30,563.72 L of water a year. These numbers assume that no snow is captured.

- Based on precipitation (including snow) data from the past 30 years between 33,216.76 L and 39,860.11 L of water can be captured if between 75% and 90% is captured.
- The above numbers do not take storage tank overflow into account.
- According to the city of Edmonton a house with a 1100 sq ft roof can save 35,800 L of water between April and October by installing a good-size rain barrel to which a hose can be attached or a watering (City of Edmonton, 2010).

**Table 29: Potential Rainwater Captured**

	% Capture	Potential Rainwater Harvested
Rainfall Only	90%	30,563.72 L
Rainfall Only	75%	25,469.77 L
Rainfall and Snowfall	90%	39,860.11 L
Rainfall and Snowfall	75%	33,216.76 L

## Xeriscaping

- The Rockyford Urban Xeriscape Demonstration project in 2003 took place in Rockyford, Alberta. Strategically placed shrubs and trees help moderate the houses temperature. Cost savings are gained by using plants suited to the climate and even growing food during appropriate weather conditions.  
[http://www.landstewardship.org/GCG/Tools/25Xeriscaping%20\(Water%20Wise%20Gardening\).pdf](http://www.landstewardship.org/GCG/Tools/25Xeriscaping%20(Water%20Wise%20Gardening).pdf)
- The unpredictable precipitation in Alberta makes xeriscaping very applicable. Water demands peak in summer months because of residential lawn watering. Albertans can drastically reduce water use up to 70% if the xeriscaping techniques are applied  
<http://www.albertaviews.ab.ca/issues/2003/mayjun03/mayjun03garden.pdf>

## Solar

- Edmonton has a good potential for utilizing solar power because it has an annual photovoltaic potential 1245 kWh/kW. Of major cities worldwide Cairo has the highest annual photovoltaic potential at 1635 kWh/kW. Edmonton's annual photovoltaic potential is comparable with Rome, Italy and Rio de Janeiro, Brazil. It is estimated that a South-facing solar panel with a tilt that was equal to latitude could have a mean daily production of 4.6 kWh/m<sup>2</sup>. This is due to Edmonton receiving over 2,300 sunshine hours per year (see map below).



Figure 40: Sunshine Hours in Alberta

## Photovoltaic's

- When sun light hits a PV cell, electrons are given off. The PV cells are placed on a panel with wires running through the cells to form a solar module. When many cells give off electrons they move between different cells creating electricity. The wires in the panel then gather this electricity and carry it out of the panel. When modules are linked in an electrical series they are known as a solar array (Sustainable Energy BPM)
- At the 2008 development at Riverdale NetZero Project in Edmonton, Alberta 11% of a houses heating needs were provided by a Photovoltaic system. This was done by installing a 28-module, 5.6 kW grid-connected PV system that is predicted to generate 6,200 kWh of electricity annually.  
[http://www.riverdalenetzero.ca/Riverdale\\_NetZero\\_house --  
project\\_profile.pdf](http://www.riverdalenetzero.ca/Riverdale_NetZero_house_-_project_profile.pdf)
- A 2001 project on a classroom building in Green Bay, Wisconsin incorporated PV Standing Seam Metal Roofing and PV Vision Glass technologies to yield the following results:

System Specifications		
	Standing Seam Metal Roof PV	Vision glass PV
System size	12.8 kW	11 kW
Installed system cost	\$95,470*	\$75,230*
Projected annual generation	15,000 kWh	12,500 kWh
Annual dollar savings	\$930	\$790

## **BIPV Standing Seam Metal Roofing**

- A portion of the building's roof uses a material called standing seam metal roofing. This material consists of long metal trays with raised edges that are snapped together to build the roof. Thin-film PV modules are glued or laminated to the tray surface. The new classroom building has 2,300 square feet of laminated modules installed on the south-facing wing.

## **BIPV Vision Glass**

- The windows in the Winter Garden atrium of Cofrin Hall use a new BIPV technology called vision glass. To the casual observer, the windows don't look different than any other window. But, they're actually generating electricity. A thin-film, semi-transparent PV panel is used as an exterior glass panel in an otherwise traditional double-pane glass window or skylight.  
[http://www.focusonenergy.com/files/Document\\_Management\\_System/Renewables/W\\_RS\\_MKCS\\_UW\\_Green\\_Bay\\_case\\_study.pdf](http://www.focusonenergy.com/files/Document_Management_System/Renewables/W_RS_MKCS_UW_Green_Bay_case_study.pdf)
- In 2003 Red River College in Winnipeg installed a PV Vision Glass curtain wall was installed on a 20,000 m<sup>2</sup> building that generates 50 kWh a day. The cost to install this system was reduced from \$100-\$125 per square foot to \$25-\$50 per square foot because it was part of the curtain wall of the building.  
[http://www.accc.ca/ftp/pubs/200504\\_re\\_factsheet.pdf](http://www.accc.ca/ftp/pubs/200504_re_factsheet.pdf)



## ***Passive Solar Heating/Lighting***

- At the 2008 development at Riverdale NetZero Project in Edmonton, Alberta 40% of a houses heating needs were provided by a passive solar heating system. The passive solar heating included features such as quadruple glazing the northern windows and triple glazing the southern windows. The walls installed were also approximately 70% more efficient at retaining heat as other walls typically used.  
[http://www.riverdalenetzero.ca/Riverdale\\_NetZero\\_house\\_-\\_project\\_profile.pdf](http://www.riverdalenetzero.ca/Riverdale_NetZero_house_-_project_profile.pdf)

## **Natural Lighting**

- Using low power lighting and energy efficient transformers help contribute to the overall reduction in energy usage. Proper switch and light control also contribute to the controllability of systems and provide improved building operation.  
[http://marketingexcellence/projectprofile\\_preview.aspx?id=10&project=13219](http://marketingexcellence/projectprofile_preview.aspx?id=10&project=13219)

## **Biomass**

- Biomass heat and energy generation are feasible for a project of this scale but may be more expensive than using natural gas or other alternative heat sources

## **Ground Source Heat Pumps/ Ice Production Waste Heat**

- *Toronto, ON-*

A facility constructed in 2001 in Colborne, ON (Near Toronto) that includes a hockey rink and a 400 person banquet hall uses air heated or chilled by either the ice rink or a horizontal earth loop for all its heating and air conditioning needs.

- *Barrhead Arena, AB -*

A facility that consists of a NHL size ice rink, a pool, a 400 person multipurpose room, and a walking track utilizes the heat generated by the refrigeration units used to make the ice for radiant floor heating throughout most of the building. The building also uses excess heat from those generators to heat the pool via an earth loop.

- *Cambridge Isanti Ice Area, MN -*

In 1998 the Cambridge-Isanti Ice Arena in Minnesota began to use a geothermal heat pump to heat the spectator stands, dressing rooms, and hot water for rink resurfacing. The geothermal pump also generates the energy used by the ice-making equipment. The heat generated by the ice making equipment is also used to heat space and water instead of being released into the air.

## **Sustainable Construction Practices**

### ***Recycled Materials:***

- Reduces the environmental impact of producing new materials: Industrial Materials Recycling (IMR) conserves natural resources and reduces the energy use and pollution associated with the production of virgin materials.
- Current estimates show that if all concrete and asphalt pavement generated annually in the United States were recycled, it would save the energy equivalent of 1 billion gallons of gasoline or the removal of more than 1 million cars from the road.

- Conserves landfill space: the beneficial use of industrial materials results in less material being sent to disposal facilities, which saves landfill space and further reduces greenhouse gas emissions and other pollutants.
- Helps avoid problems related to overloaded landfills such as groundwater contamination
- Industrial materials are often less expensive than virgin materials
- Reduces hauling and disposal costs
- Construction and Demolition (C&D) recyclers often charge less to accept recyclable materials that have already been separated from non-recyclable materials—a practice that can be encouraged at the building site by using separate containers for various materials.
- LEED credit

Sources:

1. <http://www.epa.gov/waste/conserve/rrr/imr/pdfs/recy-bldg.pdf>
2. <http://www.constructionbusinessowner.com/topics/environment-and-compliance/recycling-construction-materials-an-important-part-of-the-construction-process.html>

### ***Low Volatile Materials***

- Key signs or symptoms associated with exposure to Volatile Organic Compounds (VOCs) include conjunctival irritation, nose and throat discomfort, headache, allergic skin reaction, dyspnea, declines in serum cholinesterase levels, nausea, emesis, epistaxis, fatigue, dizziness.

### **Using low volatile materials**

- Improves regional air quality by the elimination of smog forming chemicals.
- Improves worker safety and health.
- Reduces incidents of eye and respiratory irritation, headaches, fatigue and other symptoms of “sick building” syndrome.
- Provides cleaner indoor air quality.
- Provides value-added appeal to property buyers.

Sources:

1. <http://www.epa.gov/iaq/voc.html>
2. <http://www.todaysgreenconstruction.com/2008/07/low-voc-building-materials.html>

## Air conditioner heat recovery

[www.sciencedirect.com](http://www.sciencedirect.com)

- *“Combined space cooling and water heating system for Hong Kong residences”*
- *“The use of helical heat exchanger for heat recovery domestic water- cooled air-conditioners”*
- *“Experimental study of sensible heat recovery of heat pump during heating and ventilation”*
- Can improve the coefficient of performance of a heat or cooling system by 10 to 20% approx.

## Displacement ventilation

- Works best in large open spaces – definitely possible here

*“Energy analysis for workshops with floor–supply displacement ventilation under the U.S. climates”*

[www.Sciencedirect.com](http://www.Sciencedirect.com)

- In cold environment (Portland ME): displacement ventilation is more efficient for cooling than heating, but gives overall energy savings. Humidity can be an issue, but not for a dry environment like Edmonton

*“Air flow rates and energy saving potential in schools with demand-controlled displacement ventilation”*

[www.Sciencedirect.com](http://www.Sciencedirect.com)

- A study of two schools in Norway found that using a demand controlled DV system (CO2 sensor controlled)
  - reduced heating demand by 21%
  - reduced waste heat in exhaust air by 51%
  - reduced air flow by 50%
  - reduced fan energy consumption by 87%

*Floor-supply displacement ventilation for workshops*

[www.Sciencedirect.com](http://www.Sciencedirect.com)

- Shows significantly improved air quality in a DV systems, with a slightly higher risk of thermal discomfort

## **Pool as Heat Sink**

- Use of the pool as a heat sink is an option to be explored but more detailed information is needed about the heating/cooling load expected for the building, and the size of the pool

*Energy savings in indoor swimming-pools: comparison between different heat-recovery systems*

[www.Sciencedirect.com](http://www.Sciencedirect.com)

## **Pool Water Reuse**

- Waste swimming pool water was extracted from 4 pools. Approximately 3,000 cubic meters were de-chlorinated and used to irrigate sports fields and parkland. In the past, this water was discharged to the sewer.

[http://www.edmonton.ca/environmental/documents/Envision\\_Annual\\_report\\_2008.pdf](http://www.edmonton.ca/environmental/documents/Envision_Annual_report_2008.pdf)

## Sources

### **Solar:**

SESCI-NAC - [Solar Energy Society of Canada - Northern Alberta Chapter](http://www.solaralberta.dabbledb.com/page/solaralberta-installdsites/LvQDlyxa#)  
<https://solaralberta.dabbledb.com/page/solaralberta-installdsites/LvQDlyxa#>

Solar Thermal Water Heating: An Application for Alberta, Canada – find it!

“Spatial insulation models for photovoltaic energy in Canada “  
[www.sciencedirect.com](http://www.sciencedirect.com)

Photovoltaic maps and resource potential for Canada  
Edmonton: <https://glfc.cfsnet.nfis.org/mapserver/pv/municip.php?n=720&NEK=e>

Photovoltaic municipal rankings in terms of yearly PV potential (for South-facing PV panels with latitude tilt)  
<https://glfc.cfsnet.nfis.org/mapserver/pv/rank.php?lang=e>

Alberta solar projects  
<http://www.lassothesun.ca/pages/solar-sites.htm>

### **Sustainable Rec Centers**

<http://asi.fullerton.edu/src/designefforts.asp>  
<http://asi.fullerton.edu/src/downloads/sustainablefeatures.pdf>

[http://blogs.calstate.edu/cpdc\\_sustainability/?p=121](http://blogs.calstate.edu/cpdc_sustainability/?p=121)

[http://epa.gov/brownfields/sustain\\_plts/factsheets/laredo\\_susfs.pdf](http://epa.gov/brownfields/sustain_plts/factsheets/laredo_susfs.pdf)

### **Ground Source Heat Pumps**

[http://www.nordicghp.com/mg/nordicJul-25-04/Green\\_Solution/GlobalWarmingImpactGHG2003.pdf](http://www.nordicghp.com/mg/nordicJul-25-04/Green_Solution/GlobalWarmingImpactGHG2003.pdf)

### **Permeable Pavement:**

Toronto and Region Conservation, “Performance Evaluation of Permeable Pavement and a Bioretention Swale”, 2007 Available at <http://www.icpi.org/myproject/Senecareport.pdf>

### **Geothermal**

[http://www.icekubesystems.com/htmlfiles/CASE\\_STUDIES/the\\_keeler\\_centre.asp](http://www.icekubesystems.com/htmlfiles/CASE_STUDIES/the_keeler_centre.asp)  
[http://www.icekubesystems.com/htmlfiles/CASE\\_STUDIES/barrhead\\_arena.asp](http://www.icekubesystems.com/htmlfiles/CASE_STUDIES/barrhead_arena.asp)  
<http://www.wapa.gov/es/pubs/esb/1999/99Feb/contents.htm>

## Appendix D: Recreation Center Charette Results

### *Meeting Outline*

- **Owners input (City of Edmonton, Alberta)**
  - Taking a “whole site” approach to sustainability is encourages, in order to incorporate the landscaping and fields
  - Return on investment criteria.
    - If the return on investment in 8-10 years than city will most likely go forward.
    - If return on investment is over 10 years city will factor in the energy savings before deciding pursue strategy or not.
  - Must ensure building is “operable.”
    - Operating costs are likely to be squeezed, so strategies to reduce operation costs are attractive.
    - Operating systems should be simple, reliable, and low maintenance.
    - If the building is not operated correctly than the building’s sustainable goals will not be reached.
    - The use of grey water systems is discouraged due to most cases being “messy, hard to maintain, and high operating costs”.
  - Not interested in using rainwater harvesting for use within building.
  - Interested in bioswales.
  - Interested in sustainable building performance beyond LEED.
    - Council has a strategic plan to conserve energy and reduce greenhouse gases.
    - Focus on energy savings and reducing carbon footprint.
    - Consider the use of retrofitting halogen lights, heat exchangers (Clareview Twin Arena as example), solar walls, and geothermal.
    - Potential for feeding back into the energy grid
  - Discourage the use of “buying credits” for LEED.
  - Public perception of sustainability is important
    - If systems are hidden, the benefits to the environment may not be obvious
    - Must determine if sustainable practices are accepted by users (Example: no water urinals).
- **Heat savings strategies.**
  - Producing a high quality building envelop is an effective technique to conserve energy.
    - Good insulation is important, although after a point it becomes less cost effective to continue insulating



- Windows that conserve and accentuate natural heat in winter do so in summer as well.
    - Solar walls help heat in winter and cool in summer.
  - Utilize waste heat to heat other systems (heat recovery systems).
    - Waste heat can be used to heat pool.
      - May need to localize mechanical systems near pool to achieve sustainability.
    - Waste heat can be used to heat domestic water.
      - Can be done from condensing heaters.
      - Condensing water heaters (direct heat exchange) may be a good alternative to solar water heaters.
      - Single gas vents heating systems have efficiency of 80%.
      - Gas fired boilers installed on site should be at a minimum 88% or 89% efficient
  - Ground source heating and cooling systems.
    - Drilling into ground horizontally is more cost effective than drilling vertically.
    - Drilling horizontally under sports fields may be feasible due to the large field area.
    - Look into impact on carbon emissions
      - Installing the system may produce a significant impact
  - Cogeneration heat generation.
    - Appropriate size system must be designed to ensure no wasted heat.
    - May not provide all of the electricity needed.
    - May need to explore options such as shutting system off in summer to ensure maximum efficiency.
    - Most likely used in conjunction with other systems (absorption chiller).
  - Reuse air in HVAC systems to prevent need to reheat air.
    - Must ensure air quality.
- **Electricity saving strategies.**
  - Solar photovoltaic (PV) electricity systems.
    - PV stand alone system likely will be cost prohibitive.
    - Hybrid PV system could be a feasible option.
      - Hybrid system could include solar water heating for the pool
  - Daylight harvesting to reduce artificial light demand.
    - Large windows in library can serve to light the room naturally
  - Occupancy sensors to help reduce lighting demand.
    - Systems can be designed to be simple or complex depending on energy savings desired.
  - Outside solar lighting could be used to save energy
    - High initial cost
  - LED lights have higher initial costs but may help reduce operation and maintenance costs by reducing electric demand.
    - Use T5 electrical fixtures and multi-switching.
      - Simpler systems are preferred.
    - LED light is more focused than traditional lighting systems.

- Less light pollution, higher initial cost, lower operating cost.
    - May not be suitable for outdoor walkways due to safety concerns.
  - In areas where LED lighting is not applicable, fluorescent lighting should be used.
  - Pools and ice rinks consume large amounts of energy.
    - Use VFD drives on water pump systems save energy.
    - Less water in the system means less water to decontaminate, pump, and heat/cool.
    - Pool covers may save energy, although there may be operational objections to using them.
    - Whirlpools and spas use large amounts of energy to heat and sanitize
- **Building environmental strategies.**
  - Whirlpools have negative effects on air and water quality.
  - Water purification systems.
    - Sand filters require large amounts of space.
    - Saline pools could be used to help water quality.
    - No grey water reuse.
    - Need to avoid halogen byproducts from disinfection systems.
      - Ozone or UV disinfection.
      - Need to consider mechanical system footprint (sand filters use large amounts of space).
- **Outdoor water and wastewater management.**
  - Rainwater harvesting to irrigate fields.
    - Many fields in city are not irrigated.
    - New type of irrigation system has been developed.
    - Cistern to store irrigation water from harvested rainwater could be installed.
    - For irrigation in Edmonton, a large quantity of water is needed.
      - Calgary Mall case study
  - Use drought resistance plants to reduce water demands.
    - American elms were mentioned as a possibility.
  - Vegetated swales are a promising option for stormwater management.
    - Bioretention pond to store excess rainwater?
  - Edmonton water conservation task force may be a useful resource.
- **Other sustainable considerations.**
  - Carbon emissions.
    - “Net zero carbon options.”
    - Project in Colorado pursuing “net zero” strategy.
  - Dynamic energy transfer.
  - Synthetic ice.
  - Displacement ventilation and radiant cooling can maintain user comfort (particularly in the library).
    - Save significant energy in ventilation systems
  - Green roofs
    - If used it would likely be an extensive green roof due to cost.

- Reflective roof more likely.
    - Public relations can be improved by green roof.
  - Lighting for pool access should be accessible from pool deck.
  - Acoustics should not be allowed to “fall through the cracks”
  - Workability is a factor to consider, and has already been incorporated into design
    - One indoor and one outdoor park drive will connect the facility and nearby road to the nearest transit station
    - Connector road has support of transportation department, and may be used to reduce parking spaces
  - One of the architectural goals is to integrate the building and the landscape together, so that the building feels linked with the sport fields and outdoor areas
  - Reduction of staff can be achieved by increasing sightlines inside building.
  - Pool lighting should be positioned for easy maintenance (no lights directly over pool).
- **LEED considerations.**
  - LEED does not consider the efficiency of process systems in typical criteria, but efficient process systems can be used to achieve a LEED innovation point.
  - LEED site borders need to be defined.
  - LEED US 2009 vs. LEED Canada standards.
  - LEED will have an acoustics target soon
- **Modeling.**
  - LEED Compliance Model can be used to assure LEED goal
  - Design Assistance Modeling can provide preliminary calculations for energy conservation.
    - Allows easy review of numerous scenarios
- **Next Steps.**
  - Meeting with the EDC on March 2<sup>nd</sup>.
    - A description of the systems incorporated into the project need to be written by then.

## **Appendix E: Stantec Employee Interview Questions**

A list of relevant questions was drafted relating to the practices covered in this BPM, and emailed to a list of Stantec employees who were indicated to be knowledgeable on this subject by the employee directory on StanNet (Stantec's internal network). The questions are listed here, followed by any useful answers given by the interviewees.

### ***Green Roof Interview Responses***

1. What type of experience do you have working with green roofs?

- Employee 1: "We have completed green roofs for two clients (one is a project on its way to LEED Gold), have a number of projects that should be built/executed this summer, plus several in the early planning stages"
- Employee 2: "We've worked with a few owners and architects to utilize green roofs to lower the stormwater management impact from a few of our projects and also to help with a project's marketing."

2. What cost range per square foot (or square meter) have you found to be a good estimate for green roofs versus regular roofing for any projects you worked on or know about?

- Employee 2: "Not sure about square meter, but we've seen a 5,000 SF green roof go for \$14/SF and a 50,000 SF roof go for about \$10. This does not include the cost to install. This is only for the plugs, soil, and oversight during installation."

3. In your opinion when is an intensive green roof worth the additional cost over an extensive green roof?
  - Employee 1: “when the more varied planting will be enjoyed by a substantial audience”
  - Employee 2: “I have yet to be involved with a project with an intensive green roof. I believe however, that there are a variety of factors that could play into answering this decision such as the client’s preference for the roof’s use, government funding/grant money allocation for green roof, etc...”
  
4. What are the most important factors in determining the suitability of a green roof for a particular job?
  - Employee 1: “client goals, visibility and intended use of the roof, condition of existing membrane and deck, adequacy of structural systems, costs and benefits of ancillary work (increasing access to roof, addressing ADA and regulatory issues), etc”
  - Employee 2: “The use of the building (i.e. whether the roof will it be owned by numerous people (condo ownership), will the building be leased to various tenants such as with a strip mall, etc.), whether or not the structure can support the green roof, whether the owner is willing to pay to have the green roof maintained, affordability, climate, does the roof have proper drainage, etc.”
  
5. Are there any major disadvantages to green roofs besides cost? Has runoff water quality been an issue?

- Employee 1: “related to cost is the importance of high quality standards in design/construction/installation, to control the life-cycle risks and costs of maintenance and repairs”
- Employee 2: “Disadvantages would be additional building maintenance to maintain the plantings (though sedums tend to need much less maintenance than most plants), and if grid system is not used than roof maintenance would be an issue.”

6. What are the biggest challenges in designing a green roof? What sort of structural loads might be induced by different types of green roofs?

- Employee 1: “requires a long answer, depends on whether/how occupied and type of plantings intended. anywhere from 10psf to 100+psf”
- Employee 2: “We’ve been told by green grid solutions that their 8” thick roof with sedum plugs weighs about 30 lbs/SF wet. We do not design the structure of the building so this would be a question for a structural engineer.”

7. Are there any lessons learned or best practices that you think would be helpful for others to be aware of when designing and building a green roof?

- Employee 1: “engage expert and unbiased consultants at the start and complete a due-diligence planning process before making decisions on if or how to proceed.”
- Employee 2: “I would advise to use a grid system for the reason of roof maintenance unless the client is comfortable with the idea of eventually digging up the green roof, or sections of the roof in order to maintain the actual roof’s impermeability. I would also advise the plantings have already taken root before planting to ensure a better chance of survival during non-growing season.”

8. What types of advances are being made with Green Roof technology? Where do you see this technology heading in the future?

- Employee 2: “I see green roofs being made allow for easier relocation for maintenance the actual roof’s maintenance. For green roofs to become more popular the manufacturers will have to address the question of roof maintenance. The costs will need to lower as well, which would hopefully occur as the roofs become more prevalent.”

9. Do you know of any additional resources that might be helpful to me?

- Employee 1: “there are lots, but you might see if these folks are still at work: <http://ccsr.columbia.edu/cig/greenroofs/index.html> (an academic approach to the study of green roofs, including collaboration w/ ConEdison at the Long Island City Training Center)”
- Employee 2: “ [www.greengridroofs.com](http://www.greengridroofs.com) and <http://www.greenroofplants>”

## ***Permeable Pavement Interview Responses***

1. What type of experience do you have working with permeable pavements?
  - Employee 1: I have experience with permeable Pavers, not permeable asphalt or concrete pavements to date.
  - Employee 2: I worked on a project back in Holland with this product. It was in a little town that was threatened by floods because of heavy rain. We used interlocking permeable concrete pavement to prevent these floods. The whole town is built on a sand dune which is an ideal foundation for permeable pavement.
  - Employee 3: Only a few projects that have gone to construction as of now. Many projects consider using permeable but often shy away to keep water from influencing building foundations (sites w/ expansive soils).
  - Employee 4: I have little experience with permeable pavements. A little more with permeable paving units, such as aquapave etc.
  
2. What are the major differences between different types of pavements in your experience? Do porous asphalt or concrete provide different/better storm-water management given certain site criteria? Do interlocking pavements and/or grid systems provide better results?
  - Employee 1: Interlocking pavers typically are better but use is restricted to low traffic area
  - Employee 3: While we have not specified asphalt or concrete, these are better suited for high vehicular traffic areas. Our work to date has been to design parking spaces or site hardscapes with interlocking pavers. Please note that public works agencies are very reluctant as of yet to accept porous or permeable materials for public streets and facilities.



- Employee 4: We have put in porous asphalt on roads as a wear surface - impervious below - this produces a quieter ride and does help with water - though you need to make sure your gutter is low enough to allow the water to laterally move into the gutter pan. No experience with porous concrete - an engineer in town has tried it and likes it - though most engineers are still skeptical as there is little historic information on long term performance and with clients not wanting to take ownership for the "risk" it still hasn't caught on.

3. How does permeability affect the strength and durability of these pavements?

- Employee 1: See above
- Employee 2: I don't believe there is any effect for the strength. However over time the pavement can get clogged up because of dirt on the road. This has to be maintained to keep it permeable.

4. How effective are these systems at reducing run-off volume? Are there any other benefits?

- Employee 1: This is the subject of several studies. One of our suppliers has some software which can assist in this. I will see if I can find and forward.
- Employee 2: Depending on the foundation the road is built on (a permeable foundation like sand is preferable) the runoff can be reduced to 0. The road can basically be built with no cross slope and all storm water will drain through the pavement, through the foundation and will eventually reach the groundwater.
- Employee 3: To be conservative, we do not recognize permeability of hardscapes in our drainage calculations. I suggest that you search for information from manufacturers.
- Employee 4: I think good at reducing runoff - maintenance is the concern - apparently you need to "vacuum" out the porous concrete to keep them flowing.

This seems onerous and to be honest I have little confidence in that. Think about it - over time "life" in the form of algae or moss or whatever is going to grow in the voids - it has light, it has air and it has water - what a perfect environment. I feel overtime the porespace will fill up with life if not dust, sand etc. I would have concerns using permeable concrete or asphalt where sanding and salting are part of the snow / ice removal program.

5. In your experience do these systems cost more than impervious pavements?

- Employee 1: Yes
- Employee 2: The installation cost is likely to be higher and there is a maintenance cost but there is no need for catch basins.
- Employee 4: I understand permeable pavements are more expensive - not sure by how much but would guess at say 25% premium.

6. Other than reducing the need for conventional storm-water systems, how else do permeable pavements produce cost savings?

- Employee 1: Permeable pavers do not necessary reduce the need for conventional storm water systems, because in extreme conditions, (i.e. saturated or frozen ground) a conventional system may still be required.
- Employee 4: I don't believe they do. They can be used to get credits for LEED reduced heat island effect - that is good. Permeable pavers will allow water to evapotranspire which has a cooling effect.

7. Are there any disadvantages or major risks involved in employing permeable pavement?

- Employee 1: Cost associated with regular maintenance and overall strength of this pavement
- Employee 2: The foundation and subsoil need to be investigated to determine the percolation. If the engineering is not done properly it is possible the system does not work and you will be left with a permanent pool of water on the road since there are no catch basins.
- Employee 3: Potential settlement on pavements, influence of percolated water on adjacent building foundation systems, maintenance costs when porous nature of the pavement gets silted up, and potential liability of trip hazards associated with ungrouted pavers.
- Employee 4: Plugging, freeze / thaw, strength, risk of spending the money to put it in - then having to pull it out because it failed prematurely. Also as its permeable will moisture wick up from below easier resulting in black ice?

8. What are the most important factors in determining the suitability of permeable pavement for a particular area?

- Employee 1: Your client and who pays for maintenance.
- Employee 2: The financial factor is very important. Is there a risk of flooding?
- Employee 3: Maintenance and liability issues
- Employee 4: Need to have a good environment that doesn't involve sanding / snow removal - (My opinion). Perhaps California? Sidewalks etc.

9. Are there any lessons learned or best practices that you think would be helpful for others to be aware of when incorporating permeable pavement into a project?

- Employee 4: I don't think permeable pavers have been objectively tested long enough. Most tests I feel have been done by those with special interests or

wanting it to succeed and not looking at it objectively. Perhaps I'm wrong on this.

10. What advances do you see in the future regarding permeable pavement?

- Employee 1: More practical in drier and warmer climates. Stay away from West Coast and colder climates.
- Employee 4: Advantage for the future - if it works in the long term - it would be great at naturally recharging aquifers, maintaining base flow in creeks, providing treatment, reducing infrastructure costs associated with piped drainage – i.e. fewer catchbasins, perhaps a smaller pipe diameter (pipe will still be needed as permeable pavements will not infiltrate everything).

11. Do you know of any additional resources that might be relevant to this subject?

- Employee 2: There is lots of information from for example concrete suppliers about these kinds of pavements in Holland. I have never seen or even heard anyone talking about permeable pavement in Canada. You can look on the website [www.aquaflow.nl](http://www.aquaflow.nl) but it is all in Dutch. I asked them if they have any documentation in English. I'll let you know if they have something.

## ***Stormwater Runoff Infiltration Interview Responses***

1. What type of experience do you have working with bioretention systems?

- Employee 1: Only 1 facility from the design stage in Ottawa, which was a large filter. It was proposed to provide improved bacteria removal and was preferred by the public since it could better represent the highly vegetated/treed area that was previously situated there. In essence, stormwater runoff would enter a junction chamber where it could be controlled to enter the facility which was broken up into 3 cells. Level spreader up-welling trenches were used to evenly distribute the inflow over a vegetated filter strip before the water entered the facility. This was easier designed than constructed. The cell contained a specific soil-mixture to filter and treat the water and incorporated an underdrain system to collect the effluent and release it to the watercourse. Each cell could store a certain volume within the soil matrix as well as on the surface, which was controlled by an overflow structure connected to the outlet. There was also a bypass structure to direct high-intensity storm events greater than the frequent storms directly to the river. Our [Canada's] Ministry of the Environment required that we incorporate an intensive monitoring program. The last I heard, this wasn't done right away.
- Employee 2: The Reservoir Pollution Reduction Project (173529023 - City of Columbus, Ohio) included the design of green infrastructure (i.e. bioretention systems, bioswales, pervious pavements, etc.) in an effort to improve the quality of the City of Columbus' drinking water by reducing the pollutants contained within the surface water prior to discharging into the reservoirs.
- Employee 3: Designed two systems - one for treating water quality volume at a State park-and-ride facility, and one for treating water quality volume and infiltrating entire one-year storm volume for a new hangar at Burlington International Airport. The design of both systems involved a

landscape architect to develop the planting plan. These systems can be very attractive if maintained properly.

2. How effective are these systems at reducing run-off volume and removing contaminants?

- Employee 1: My understanding is that they are highly effective at removing contaminants, and if you have suitable soils to infiltrate into, you can also reduce volumes. My example did not have suitable soils, and there was concern of river bank stability so we needed to have a clay liner on the facility.

3. What are the major differences between different types of systems in your experience? Do rain gardens or vegetated swales provide different/better storm-water management given certain site criteria?

- Employee 2: As you state in your question, site conditions are often the determining factor in choosing a BMP. Pollutant removal is affected by various factors (i.e. the type of soil and vegetation present). Stormwater management is provided through infiltration, evapotranspiration, plant uptake, etc., which, again, vary based on site conditions. I hesitate to say that one BMP provides "better" SWM than another; instead, I will say that various BMPs can provide effective SWM functions, given the right site conditions and routine maintenance of the system.
- Employee 3: No studies have been conducted to determine effectiveness of these systems. The airport system was designed to infiltrate the entire 1 year runoff volume that discharges into the system which contributed toward a zero 1 year runoff design for the entire project. Unfortunately, there is no requirement to study the effectiveness of these systems in Vermont. If the design standards

are satisfied, these systems have assumed effectiveness based on empirical data not local to the area.

4. In your experience do these systems provide a net cost benefit? If so how much/what is the payback period?

- Employee 1: Don't know. Balance the intensity and frequency of maintenance versus the up-front capital costs. Monitoring is another factor to consider. Also, often the footprint of these types of facilities are not as efficient (in terms of land cost) for some developers. So it depends.
- Employee 2: The net cost benefit of these systems will vary from project to project; however, these systems will only provide long-term benefits if they are properly maintained. An O&M plan must be in place prior to the construction of any BMP, because without proper maintenance, the lifespan of one of these systems can be very short.
- Employee 3: Qualitatively speaking, both systems provided a net cost benefit. The park-and-ride system was placed in an area already slated to be landscaped and saved costs associated with land acquisition, construction and maintenance of a wet pond. The airport system performed the same function, but also had the added benefit of infiltrating the entire 1 year runoff volume.

5. Other than reducing the need for conventional storm-water systems, how else can bioretention areas produce cost savings?

- Employee 2: Bioretention areas are relatively expensive. The primary means of cost savings is the reduction of conventional stormwater conveyance systems. Bioretention areas also often consume more land (roughly 5% of total drainage area) when compared with traditional stormwater practices; however, this land can often be counted in required setback and landscaped areas.

- Employee 3: If they are incorporated into an area already slated to be landscaped, they can be less costly to maintain than a pond, wetland, or underground system.

6. Are there any disadvantages or major risks involved in employing bioretention areas?

- Employee 1: Major risk is ensuring that it performs as intended (monitoring) at the on-set and in the long-term. Construction is sensitive for many types, so proper selection of suitable contractors to perform the work (and make sure they know what they're given ample direction).
- Employee2: Bioretention areas require routine maintenance for long-term functionality; they are often susceptible to clogging by sediments; and they effectively treat only a relatively small drainage area.
- Employee 3: May be considered a wildlife attractant which is not desirable for projects near airports. We got around this by specifying tree and shrub species that are not considered wildlife attractants. I don't see any major risks. Normally these systems are designed with overflows, so flooding is not a concern. Clogging may be a concern, but can be easily corrected. Difficult to determine effectiveness, unless post-construction study is performed or inspections occur during rainfall events similar to design storm intensities.

7. What are the most important factors in determining the suitability of a bioretention area for a particular area? Is weather/climate a determining factor of suitability or simply an additional design criterion?

- Employee 1: For bioretention, it should be soil conditions. Climate (especially if freeze-thaw cycles are of concern), should be considered. In Ottawa, we had to



design our facility to not be in operation in the winter - additional risk of bypass of untreated effluent is a possibility unless there's a contingency treatment system.

- Employee 2: Soils, vegetation, and other site considerations (i.e. groundslope) are important factors. Weather/climate is also an important factor. Bioretention areas will not function well in cold weather climates due to dormancy of vegetation and frozen soils.
- Employee 3: Soil types (to determine if underdrain system is required). Anti-icing/de-icing methods used on surrounding impervious areas (i.e. is sand used heavily). Cold climate considerations are recommended (not required) design criteria in Vermont.

8. Are there any lessons learned or best practices that you think would be helpful for others to be aware of when designing and building a bioretention area?

- Employee 1: Be sure to involve appropriate technical staff (hydrogeologists, water resources engineers, landscape architects, ecologists etc.) as well as construction contractors.
- Employee 2: Bioretention areas must be designed to completely drain water from the 0.75 inch rainfall in greater than 24 hours but less than 48 hours. Perforated standpipes, or other vertical outlet structure, are effective multi-staged outlet structures.
- Employee 3: Include soil testing requirements by the local agricultural extension or a soils testing laboratory in the specification to ensure the bioretention soils meet specs. The civil engineer designs the system for stormwater function (treatment and management), and the landscape architect should have input on plant species for aesthetics.

9. What advances do you anticipate for the future regarding bioretention areas?

- Employee 1: Better understanding of long-term performance as monitoring data is collected and analyzed
- Employee 2: I anticipate that as more bioretention areas are constructed and their long-term performance studied, their use as a stormwater management device will begin to be restricted to areas that have existing soils with appropriate infiltration rates.

## ***Rainwater Harvesting Interview Responses***

1. What is your experience with rainwater harvesting?

- Employee 1: Worked on the design for rainwater harvesting systems for the Southface Eco Office in Atlanta Georgia and the Grand Bay National Estuarine Research and Reserve project in Alabama, I was working on a Spa that was planning to use significant rainwater harvesting, but the project went on hold.

2. In your experience what are the most common applications that harvested rainwater have been used for?

- Employee 1: Toilet flushing and "rain gardens" in buildings that have an educational function.

3. In your experience how much potable water do rainwater harvesting systems save?

- Employee 1: In the Southeast US, these systems can save a significant amount of water, because the rainfall is pretty regular throughout the year.

4. In your experience how much do rainwater harvesting systems cost?

- Employee 1: Don't have any hard data, though I can tell you this is largely related to the storage requirement- which will vary drastically based on typical weather patterns.

5. In your experience are rainwater harvesting systems cost efficient? Are there any characteristics that make them more efficient?
  - Employee 1: Barring unusual circumstances, I don't think these systems are cost efficient. Water is too cheap.
  
6. Do you have any suggestions for designing the size of rainwater harvesting storage tanks?
  - Employee 1: Really depends on the weather patterns and the intended use. I typically start out doing a monthly comparison of typical rainfall volumes to water demand.
  
7. What are the most important factors in determining the suitability of a rainwater harvesting system for a particular area?
  - Employee 1: Frequency of rainfall during the dry season. In the Western US, we have pretty dry summers, so required storage capacities can get pretty big.
  
8. Are there any lessons learned or best practices that you think would be helpful for others to be aware of when designing and building a rainwater harvesting system?
  - Employee 1: Pay extra attention to the refill/backup strategy for the water system. Cross connection is an important issue.
  
9. What advances do you anticipate in the future of rainwater harvesting?

- Employee 1: More uniform and sensible laws regarding its use. Water treatment products focused for the market- ozonation/ultrafiltration etc.
- Employee 2: I helped/critiqued a group of landscape architect graduate students at University of Penn who were working on their studio that focused on sustainable growth in Jordan. Water reuse/renovation was key to any sustainable growth in the region. Rainwater harvesting would only be applicable in regions with a lack of sufficient sources of potable water. Here on the east coast we have surplus so rainwater harvesting would be unnecessary.

## ***Constructed Wetlands Interview Responses***

1. What is your experience with constructed wetlands?

- Employee 1: I have designed, reviewed and evaluated 7 wetlands in 5 states and Canada in the last 15 years.
- Employee 2: Designed systems for treating wastewater from single family homes. Designed and permitted wetland based system for treating landfill leachate. Designed a wetland based treatment system for treating an acidic (metals saturated) discharge from a titanium dioxide mining operation. Designed wetland based treatment system for treating an acidic (iron and manganese saturated) discharge from a former clay mine where they left the coal seam in the ceiling of the mine. Designed wetland based stormwater treatment systems.

2. In your experience what are the most common applications that constructed wetlands have been used for?

- Employee 1: All of the wetlands I involved with are used for polishing treatment and disposal after primary treatment by aerated lagoons or other type of aerobic treatments. Of the 7 wetlands I involved, 5 wetlands are free surface wetlands using to treat and dispose of the lagoon effluents by evapotranspiration (ET) process, one is used to polish lagoon effluent prior to discharging to the ocean, and one is to used for polish and dispose of septic effluent to groundwater.
- Employee 2: In Pennsylvania, acid rock/mine drainage and stormwater treatment.

3. Do you have a preference between using free water surface flow, horizontal subsurface, or vertical subsurface flow wetlands? If so, why?

- Employee 1: For non-discharge wetland systems, I have used free water surface flow wetland because of free water surface have higher evaporation rate, and reduce footprint requirement. For discharging wetland, I used subsurface flow wetland which is more effective for remove solids and organic loading because solids are removed by filtration and sedimentation in this type of wetland, and organic loading are removed by bacteria in the wetland media and roots of the vegetation.
- Employee 2: It is completely dependent on what you are treating. The leachate system included an equilibration pond, a free water surface flow wetland followed by a vertical subsurface flow wetland. The metals removal ones required successive anoxic producing ponds (vertical flow through an organic layer to strip off oxygen) followed by precipitation ponds and a wetland at the end to polish and remove the final trace to background concentrations. Plus all the iron had to be removed before you can get the manganese to drop out. The wastewater from the single family house had two, a surface flow wetland since the wastewater was coming in from a pump chamber following the septic tank and needed an aerobic treatment that flowed into an anaerobic cell with up flow hydrology finishing in a surface flow wetland. It's all about whether you need the anaerobic or aerobic bacteria to do the work for you.

4. In your experience how much do constructed wetlands systems cost?

- Employee 1: Capital cost of wetland varies greatly depending on local labor, availability of wetland media, climate conditions for non-discharge system, and site conditions such as groundwater, soil etc. But operation and maintenance cost for the wetland is very low, almost nonsexist since this is a natural treatment process. The vegetation can be harvested every 3 to 5 years. Most operator just

burn vegetation in the winter. The operator only need to inspect the wetland dikes periodically to ensure they are not nutria, beaver or other water animals.

- Employee 2: It's all over the map but I can tell you that the single largest cost is the earth moving.

5. In your experience are constructed wetlands systems cost efficient? Are there any characteristics that make them more efficient?

- Employee 1: they are cost effective solutions for small remote wastewater treatment systems, such as national or state parks, highway rest areas, where a non-discharge wetland have worked really well because wetland capacity variation (high in the summer, low in the winter due to evaporation changes) often parallel the visitors (high in the summer, low in the winter). The wetland is also very cost effective for polishing lagoon effluent prior to discharge. Effluent quality from the wetland is comparable to effluent from expensive sand filters or cloth media filters used mostly in mechanical plants. I have 3 years of performance data from a project using shredded tire chips as wetland media, effluent CBOD5 and TSS from wetland are consistently below 5 mg/l. fecal coliform is generally less than 200 cfu/100 ml.
- Employee 2: Very. Maintenance consists of "if it's green and growing its working." The one I designed for the single family home was about 30% cheaper to design, permit and construct than the "conventional" system that it was compared to. It also didn't need any UV disinfection prior to discharge.

6. What are the most important factors in determining the suitability of a constructed wetland system for a particular area?

- Employee 1: Project location (remote or near other sewer system), climate (very little precipitation or lot of it), land availability and flow rates. Because of



extensive land requirement, large flow is probably cost prohibitive in terms of capital cost.

- Employee 2: Land cost because they take more space than concrete and steel and regulatory acceptance.

7. Are there any lessons learned or best practices that you think would be helpful for others to be aware of when designing and building a constructed wetland?

- Employee 1: I have learned some lessons in using tire chips as wetland media. They are included in the draft paper I prepared for publication in Water Environment and Technology (WE&T) journal in this fall.
- Employee 2: Make sure you get the hydrology right. It is the most critical component of the design. Residence time drives removal/treatment rate and the hydrology determines which plants live. Always have a biologist and an engineer co-design. If you are missing one or the other you are setting yourself up for high probability of failure. Engineers don't understand biology and biologists don't understand how to design hydrology.

## ***Xeriscaping Interview Responses***

Employee 1: Eco-region maps can provide a good general idea of native plants that will do without supplemental irrigation. Also, native grasses are becoming more common in landscaping for ornamental reasons. Prairie grasses are suited for most types of earth, even very sandy soils. They have approximately 60% of biomass underground and half of that decomposes. That part will re-grow and improve the soil for a more diverse plant community. Also, by putting a crisp orderly frame around xeriscaped areas, the design is much more accepted by the community because it is more ascetically pleasing.

## ***District Energy Systems Interview Responses***

1. What type of experience do you have working with district heating/cooling systems?
  - Employee 1: “Mainly working on studies and the heat input systems (such as biomass combustion heating systems) “
  - Employee 2: “Primarily feasibility study / business case development / conceptual design “
  - Employee 3: “District Heating: Feasibility studies, design/specifications/construction dispute mediation. District Cooling: Conceptual studies. “
  
2. What are the most common types of systems in your experience?
  - Employee 1: “The European systems that we have used as models are tending to use biomass for the heat input but Waste to Energy Plants are also used as we as waste heat from other industrial plants such as waste heat from condensers from large thermal power plants. Hot water and steam systems are both used for the distributing the heat to the buildings. “
  - Employee 2: “District heating and cogeneration “
  - Employee 3: “District heating: existing systems, steam 15 psig – 150 psig. New systems, hot water, 90°F – 120°F. Thermal fluid, 350°F.”
  
3. How effective are these systems at actually providing adequate heating/cooling to buildings?

- Employee 1: “These systems are effective at providing adequately heat to the buildings providing they are sized correctly. “
- Employee 2: “Can be very effective”
- Employee 3: “Charlottetown DHS when it started, was used in parallel with existing oil-fired heating. Now the oil-fired equipment has been removed by some clients who see no need for the back-up safeguard. Halifax Stanfield Airport system was converted from steam to hot water (1988) (I was lead engineer and PM). There have been no issues since then as confirmed when I bring up the project in conversations with airport facilities staff. District cooling is harder to justify in Atlantic Canada because the climate is more temperate. New office buildings on the shoreline of Halifax Harbour make use of sea water to cool the building. This facility is backed up with conventional chillers because the harbor water temperature rises beyond what the economics of heat exchanger size would dictate.”

4. In your experience do these systems provide a net cost benefit? If so how much/what is payback period?

- Employee1: “I don't have the experience to comment other than to say that the systems are usually the greatest benefit when the cost of the fuel is the lowest. IE if the fuel is waste wood from a wood processing plant then the operating cost may be much lower than a system based on fuel such as natural gas heating oil. This also depends on other factors such as the capital costs, financing cost and operating and maintenance cost. “
- Employee 2: “Cogeneration and district heating can be economically feasible, given the right energy cost environment, and in areas of high energy demand density. District cooling in my experience has been less economically attractive. “
- Employee 3: “It seems to me that DHS can show cost benefit if there is a substantial new demand (new building) contemplated. We studied the

potential for the Town of Truro, NS where a new hospital was to be built within reasonable distance to a potential DHS plant. In the case of Charlottetown, the economics are questionable because a lot of government funding was used. This was justified in terms of using Charlottetown as a demonstration of what could be achieved by DHS. Anecdotal information indicates that the provision of DHS to small-size commercial/residential clients is clearly a loss-situation. Discussion of pay-back period is not really relevant. It is generally accepted that “pay-back period” is a very crude measure of success. DHS is a community facility that embeds many non-financial benefits that a municipality would want. For example, the energy can be provided from natural resources (biomass, geothermal, etc.) on a scale that individual clients would not be able to install. Therefore, they could not achieve the lower cost per unit of energy output. Also, a centralized DHS plant could include for power generation (Hamilton Hospitals, Bay Area Health Commission) using natural gas.”

5. What kind of energy savings were projects you worked on able to generate?

- Employee 2: “Total energy savings have been relatively minor, due to efficiency gains. The primary environmental driver has been fuel switching to a cleaner fuel. “
- Employee 3: “The projects I have worked on all focused upon reducing costs to potential clients. They also focused on avoiding the risk of precipitous cost of fuel increases for existing heat supply. Although there may be reductions in total energy consumed by a DHS, they are not usually measured after the project is installed. A significant saving is the reduction in operations and maintenance costs for individual clients. “

6. Most of the literature about district energy discusses the benefits of such a system. Are there any disadvantages to these systems for the installer, besides the capital cost of installation? Are there any disadvantages for the end user as opposed to them having their own individual heating/cooling system?
- Employee 1: “Disadvantages may include the necessity to have higher qualified operators on duty full time (24 hr/day) if the central plant is larger than the individual plants that may be operated unattended. Also the use of inexpensive fuels such as wood waste biomass may require more sophisticated equipment such as conveyors and storage bins which will require additional expense during operation. “
  - Employee 2: “Disadvantages for the developer are often related to pressure to include small end-users for which hook up cost per unit of energy supply is extremely high. “
  - Employee 3: “The DHS installer accepts the risks of fuel supply issues. These can be mitigated by the terms and conditions attached to the billing. For example: fuel escalation adjustments. However, the local utility and review board will be involved like it is for power distribution, so it can be messy to recover from “spikes” in fuel costs. The DHS client faces the risk of failure to supply energy by the DHS operator. A decision has to be made as to the cost of such a failure versus the cost of back-up energy supply systems. This is the same as for power supply failures: how many facilities (clients) have back-up power generators?
7. What are the most important factors in determining the suitability of a district energy system for a particular area? How important is the opportunity for cogeneration in determining the suitability of a site?
- Employee 1: “The most important factor are the energy intensity of the area under consideration. IE there must be an adequate demand for the heat from

the system. Also important is the cost of fuel and a key host such as hospital that can accept large input from the system. “

- Employee 2: “My experience has been in looking at systems for industrial or large commercial / institutional users, where energy density is relatively high. I could see that for residential or small and medium commercial, it could be very challenging. Cogeneration is a key economic factor where the electrical utility is cooperative and seeking power. “
- Employee 3: “The key determining factor for applying DHS to a particular area is the density of energy demand. The cost of pipe-in-the-ground is a key factor in the economics of DHS, together with the cost of metering facilities for individual clients. Surprisingly, fuel cost is less significant than you would think in feasibility assessment. It is however, a key element in the control of over-all operational costs. Most other costs such as capital (and OMA) are beyond a DHS operator’s realm of control. They represent annual costs that are a function of the design and the equipment actually installed. Turning to the importance of co-generation in determining the suitability of a site, it is useful to consider basic thermodynamics, and economies of scale. It is easier and less expensive to convert heat energy into work (electrical) energy if the source temperature is high such as you always get when you burn fuels. Therefore, the use of fuel to feed end-user needs of energy at relatively low temperatures (<212oF) is a waste of opportunity to generate work energy. The resolution to this issue is to assess when the costs of adding machinery to produce work (electrical) energy, is worth contemplating. Larger machinery can achieve better (work) efficiencies but they need high operating hours/year to minimize cost/kWh. Also the cost of engineering and design together with the cost of hook-up with the utility, are not particularly related to plant size, so this becomes an issue. Co-generation is an issue to be addressed in concert with assessing the potential heating/cooling demand of the proposed district energy system. The key consideration will be the price/value to be assigned to the power generated. Power utilities in general see little to gain from the purchase of power from others unless it removes the need to build new plants

for themselves. There has to be legislation in place that compels the utility to purchase power from such as DES, wind farms, hydro sites, etc. at rates that provide for potential profit to the developers. Where such legislation exists, consideration for co-generation can become the over-arching project wherein revenues from power sales far exceed those from the sale of thermal (heat/cool) energy. The key factor is to gain acceptance that the electrical generation efficiency is better than 6000Btu/kWh for the proposed CHP plant.

8. Are there any lessons learned or best practices that you think would be helpful for others to be aware of when designing and building a district heating and/or cooling system?

- Employee 2: “Focus on anchor loads early, where a base demand is relatively consistent through the year. Economically, it may be hard to justify a system for purely seasonal space heating / cooling demands. “
- Employee 3: “When contemplating an opportunity for DES/co-generation, use the screening tests for assessing potential viability that are available – Google. CADDET Analysis Series: District Heating, Cooling, Co-generation. This contains publications based on European experience. Note that in Europe, the cost of energy is significantly higher than in North America, so projects have a better potential for success in Europe.”

9. What types of advances are being made with district energy technology? Where do you see this technology heading in the future?

- Employee 1: “Advance combined heat and power systems such as Organic Rankin Cycle (ORC) “
- Employee 2: “Certainly shift towards greener fuels will be a driver. “



- Employee 3: “Advances are being made that are aimed at reducing CO2 emissions (No thanks to Bush and Harper!!). Heat generating equipment and resources like geothermal, and industrial waste heat, are being considered for their ability to deliver useful energy with reduced environmental footprint. Municipalities are pushing for projects that will reduce the community’s discharge of GHGs. In Canada the biggest obstruction lies in the lack of legislation that compels emitters to reduce GHG emissions, and the lack of a trading system that would generate a market wherein the \$ value of a GHG Emissions Reduction could be easily recognized. When there is a real \$/ton value for CO2eq Credits, this will spur the installation of a number of technologies that could help reduce the cost of energy that is associated with lower emissions. “

10. Do you know of any additional resources that might be relevant to this subject?

- Employee1: “Check the following link for additional info: <http://www.communityenergy.bc.ca/> “
- Employee 3: “The Canadian District Energy Association is an obvious one, but beware the push from governments and municipalities that are desperate to be seen as pro-active by sponsoring studies that look to me to be marginal at best in their chances for success.”

# Appendix G: Capstone Design Calculations

## AIR QUALITY BENEFITS

PAGE 1/2

### → Chicago Study

- 19.8 ha = 2,131,339.26 ft<sup>2</sup> roof area
- removed 1675 kg of pollutants:
  - 52% O<sub>3</sub> = 877 kg
  - 27% NO<sub>2</sub> = 452.3 kg
  - 14% PM<sub>10</sub> = 234.5 kg
  - 7% SO<sub>2</sub> = 117.25 kg
- OF this:
  - 63% are low grasses
  - 14% are large herbaceous plants
  - 11% are trees + shrubs
  - 12% is hard surface

### → from chart:

- Extensive (short grasses ~ 0.15 m tall) (g / m<sup>2</sup> / yr)
  - O<sub>3</sub>: 4.49
  - NO<sub>2</sub>: 2.23
  - PM<sub>10</sub>: 1.12
  - SO<sub>2</sub>: 0.65
- Intensive (tall herbaceous plants ~ 1 m tall) (g / m<sup>2</sup> / yr)
  - O<sub>3</sub>: 5.81
  - NO<sub>2</sub>: 2.94
  - PM<sub>10</sub>: 1.52
  - SO<sub>2</sub>: 0.83

### → EXCEL sheet: compare pollution levels

- results of comparison:
  - O<sub>3</sub> = 3.2% less in Edmonton
  - NO<sub>2</sub> = 35.24% less in Edmonton
  - PM<sub>10</sub> = 8.73% more in Edmonton
  - SO<sub>2</sub> = 58.39% less in Edmonton

### → Edmonton Rec. Center

- 90,000 ft<sup>2</sup> = 8361.27 m<sup>2</sup>
- Extensive (short grass ≤ .15 m)
  - O<sub>3</sub> = 4.49 × 8361.27 = 37,542.12 g
  - NO<sub>2</sub> = 2.23 × 8361.27 = 19,437.77 g
  - PM<sub>10</sub> = 1.12 × 8361.27 = 9,364.63 g
  - SO<sub>2</sub> = 0.65 × 8361.27 = 5,434.83 g
- Intensive (tall herbaceous plants ~ 1 m)
  - O<sub>3</sub> = 5.81 × 8361.27 = 48,579.0 g
  - NO<sub>2</sub> = 2.94 × 8361.27 = 24,582.14 g
  - PM<sub>10</sub> = 1.52 × 8361.27 = 12,709.14 g
  - SO<sub>2</sub> = 0.83 × 8361.27 = 6,939.86 g

- Combinations (40,000 SF extensive, 50,000 SF intensive)

→ 40,000 ft<sup>2</sup> = 3,716.12 m<sup>2</sup>

→ 50,000 ft<sup>2</sup> = 4,645.15 m<sup>2</sup>

- O<sub>3</sub> = 4.49 (3716.12) + 5.81 (4645.15) = 43,173.7 g

- NO<sub>x</sub> = 2.25 (3716.12) + 2.94 (4645.15) = 21,943.69 g

- PM<sub>10</sub> = 1.12 (3716.12) + 1.52 (4645.15) = 11,272.68 g

- SO<sub>2</sub> = 0.65 (3716.12) + 0.83 (4645.15) = 6,270.95 g

→ Verify w/ study data

- Study roofs had ratio of  $\frac{37.58\%}{67.42\%}$  extensive (similar) / intensive

• 19.9 ha = 199,000 m<sup>2</sup> → 12% wet hard surface  
 = 199,000 (1 - .12) = 174,240

•  $\frac{361.27}{174,240.0} = 0.0480$

- Scale pollutant removal to our roof size

- O<sub>3</sub> = 371.0 (.048) = 41.80 kg

- NO<sub>x</sub> = 452.3 (.048) = 21.70 kg

- PM<sub>10</sub> = 234.5 (.048) = 11.25 kg

- SO<sub>2</sub> = 117.3 (.048) = 5.63 kg

✓ similar results to combined roof

→ Correct for ambient pollution levels

<ul style="list-style-type: none"> <li>• All Extensive</li> <li>- O<sub>3</sub> = 37.59 (1 - 0.032) = 36.34 kg</li> <li>- NO<sub>x</sub> = 14.48 (1 - 0.5524) = 12.62 kg</li> <li>- PM<sub>10</sub> = 9.31 (1 + 0.0312) = 10.19 kg</li> <li>- SO<sub>2</sub> = 5.43 (1 - 0.5836) = 2.26 kg</li> <li>• All Intensive</li> <li>- O<sub>3</sub> = 48.59 (1 - 0.032) = 47.03 kg</li> <li>- NO<sub>x</sub> = 24.58 (1 - 0.3524) = 15.92 kg</li> <li>- PM<sub>10</sub> = 12.71 (1 + 0.0372) = 13.22 kg</li> <li>- SO<sub>2</sub> = 6.94 (1 - 0.5836) = 2.89 kg</li> <li>• Combined</li> <li>- O<sub>3</sub> = 43.67 (1 - 0.032) = 42.26 kg</li> <li>- NO<sub>x</sub> = 21.94 (1 - 0.3524) = 14.45 kg</li> <li>- PM<sub>10</sub> = 11.22 (1 + 0.0372) = 11.70 kg</li> <li>- SO<sub>2</sub> = 6.27 (1 - 0.5836) = 2.41 kg</li> </ul>
--

# STORMWATER REDUCTION - COST SAVINGS

Cost Formula: Land Area (A) × Development Intensity (I) × Runoff Coefficient (C)  
 × Rate  
 = A × I × C × Rate

→ Rate = \$0.01232/m<sup>2</sup> (Per month)

→ I = 1.00

→ A: land area = 1.2 million ft<sup>2</sup> → 111,488.65 m<sup>2</sup>

→ ΔC = 0.1, 0.15, 0.2

1.) All extensive :  $\Delta B = (111,488.65 \text{ m}^2)(1.0)(0.01232 \text{ $/m}^2)(0.1)$   
 $\Delta B = 137.35 \text{ /month}$   
 → \$ 1648.17 /year

2.) New Intensive  
 Old Extensive :  $\Delta B = (111,488.65 \text{ m}^2)(1.0)(0.01232 \text{ $/m}^2)(0.15)$   
 $\Delta B = 206.02 \text{ /month}$   
 → \$ 2472.26 /year

3.) All Intensive :  $\Delta B = (111,488.65 \text{ m}^2)(1.0)(0.01232 \text{ $/m}^2)(0.2)$   
 $\Delta B = 274.70 \text{ /month}$   
 → \$ 3296.35 /year

## YEARLY SAVINGS

1.)	0.1	→	\$ 1648.17
2.)	0.15	→	\$ 2472.26
3.)	0.2	→	\$ 3296.35

# THERMAL BENEFITS - COST SAVINGS

→ Market Prices in Edmonton: Dual Fuel plan: \$ 7.74 / GJ for gas  
\$ 0.0774 / kWh for electricity

→ Total savings:

- for All Extensive: Heat = 3842 kWh = 13.725 GJ (7.74) = \$ 106.92  
Electricity = 4914 kWh (0.0774) = \$ 382.99
- for All Intensive: Heat = 9214 kWh = 33.35 GJ (7.74) = \$ 259.31  
Electricity = 10,819.48 kWh (0.0774) = \$ 842.34
- for Combined: Heat = 6235.65 = 22.4486 GJ (7.74) = \$ 174.87  
Electricity = 7540.01 kWh (0.0774) = \$ 593.73

→ Weather Data ←

- sources: National Weather Service (Pittsburgh)  
National Climate Data and Info Archive (Edmonton)

• Compare avg. monthly temp.

	Jan	Feb	Mar	Apr	May	Jun	Jul	Aug	Sept	Oct	Nov	Dec	AVG
Edmonton	11	17	27	42	53	60	64	67	52	42	25	15	39.0
Pittsburgh	23	31	40	50	60	68	75	71	64	58	42	33	50.4

11.9

→ round to 12°F

$$\frac{12}{50.9} = 0.235 \rightarrow \underline{23.5\%}$$

→ Pittsburgh Study Data ← (12,000 ft² roof)

- Heat: Control roof: 269,947.8 kWh/yr → 22.495 kWh/m²/yr  
Extensive roof: 269,684.0 kWh/yr → 22.474 kWh/m²/yr  
Intensive roof: 269,332.9 kWh/yr → 22.444 kWh/m²/yr
- Electricity: Control roof: 2,122,699 kWh/yr → 176.892 kWh/m²/yr  
Extensive roof: 2,115,407 kWh/yr → 176.280 kWh/m²/yr  
Intensive roof: 2,106,656 kWh/yr → 175.554 kWh/m²/yr

- Savings: Heat: Extensive - 0.021 kWh/m²/yr  
Intensive - 0.051 kWh/m²/yr  
Electricity: Extensive - 0.608 kWh/m²/yr  
Intensive - 1.338 kWh/m²/yr

→ Adjust for building energy usage

- Edmonton Arts, Entertainment and Recreation Centers:

- 2.25 million m² used 1.3 PJ electricity  
2.3 PJ Natural gas

→ Electricity: 160.98 kWh/m²/yr  
Heat: 233.9 kWh/m²/yr

- Clareville rec. Center: 90,000 ft² roof area (x 2 stories)  
= 180,000 ft² floor area  
= 16,722.59 m² floor area

→ total usage: Electricity = 4,747,529.1 kWh/yr  
Heat = 2,633,808.4 kWh/yr

- Scale usage: → Electricity:  $2,633,808.4 / 2,122,699 = 1.264$   
Extensive:  $(0.608)(1.264) = 0.769$  kWh/m²/yr  
Intensive:  $(1.338)(1.264) = 1.691$  kWh/m²/yr  
→ Heat:  $4,747,529.1 / 269,947.8 = 17.586$   
Extensive:  $(0.021)(17.586) = 0.369$  kWh/m²/yr  
Intensive:  $(0.051)(17.586) = 0.897$  kWh/m²/yr

# THERMAL BENEFITS

→ Adjust for Edmonton Climate

- Heat : 23.5% Greater

→ Extensive :  $(0.369)(1.235) = 0.456 \text{ kWh/m}^2/\text{yr}$

→ Intensive :  $(0.597)(1.235) = 0.738 \text{ kWh/m}^2/\text{yr}$

- Electricity : 23.5% Less

→ Extensive :  $(0.719)(1 - 0.235) = 0.549 \text{ kWh/m}^2/\text{yr}$

→ Intensive :  $(1.191)(1 - 0.235) = 0.909 \text{ kWh/m}^2/\text{yr}$

→ Total energy Savings :

- for All Extensive : Heat = 3512.79 kWh / year  
Electricity = 4916.43 kWh / year

- for All Intensive : Heat = 9264.24 kWh / year  
Electricity = 10311.48 kWh / year

- for combined : Heat = 6235.63 kWh / year  
Electricity = 7590.01 kWh / year

Expert Opinions: Structures = 20% of Facility cost  
 for rec. facility: total building cost = \$ 45 / SF  
 → x 90,000 SF = 34.1 million  
 [ Assume 575,000 kg of steel @ \$7 / kg ]

Research Data:

- Dugan Wellness Center (Texas)  
 (Modern Steel . Com) 67,000 SF → 392 tons of steel (structural)  
 + 62 tons of steel (Joists)  
 → 0.0063 tons steel / SF
- Torleton Stat University  
 70,000 SF → 373 tons of steel (structural)  
 + 215 tons of steel (Joists)  
 → 0.0083 tons steel / SF
- Jerry D. Morris Rec Center (Texas)  
 51,442 SF → 225 tons of steel (structural)  
 120 tons of steel (Joists)  
 → 0.0067 tons steel / SF
- Harrison Park Patriot Center  
 127,000 SF → 610 tons of steel (total)  
 → 0.0048 tons steel / SF

○ Average =  $0.0245 / 4 = 0.006125$  tons / SF

(Alberta-based steel supplier) → Cost Range for steel : \$2,500 - \$3,000 / ton  
 for production / erection  
 $90,000 \times 2 = 180,000$  SF x 0.006125 tons / SF  
 ↑  
 2 stories  
 = (1192.5 tons) x (\$2,750 / ton) = \$3,279,375  
 ROUND TO → \$3,300,000  
 → Average for 90,000 SF = \$3,700,000



Added Costs : Extensive : + 10%  
 intensive : + 100%

For Existing : original cost = 3.7 million  $\times \frac{4}{9} = 1.644$  million

for New : cost = 3.7 million  $\times \frac{5}{9} = 2.056$  million

→ Structural Cost of New Construction :  $\boxed{\$2,056,000}$

1.) all extensive : assume that 10% upgrades will be needed to existing,  
 and 10% will be added to new

$$\rightarrow 3.7 \text{ million} \times 0.10 = \boxed{\$370,000}$$

2.) all intensive : upgrades to existing structure will be cost-prohibitive

→ N/A

3.) extensive existing :  $\$1,644,000 \times 0.10 = \$164,400$

intensive new :  $\$2,056,000 \times 1.00 = \$2,056,000$

$$\boxed{\$2,220,400}$$

Assumptions:

1. Existing Building: 200' X 200' (40,000 SF)
2. Proposed Expansion: (300' X 100') + (200' X 100') = (50,000 SF)
3. 50% stormwater absorbed by extensive roof
4. 80% stormwater absorbed by intensive roof
5. Only rainwater is captured by roofs.
6. 6.23 gal H<sub>2</sub>O captured per 1 SF for each 1" of rain

Existing Building

$$40,000 \text{ SF} \cdot \frac{6.23 \text{ gal/in}}{1,000 \text{ SF}} = 24,920 \text{ gal/in}$$

$$24,920 \text{ gal/in} \cdot 14.4 \text{ in/yr} = 358,848 \text{ gal/yr}$$

$$358,848 \text{ gal/yr} \cdot 3.84 \text{ gal} = \boxed{1,363,622.4 \text{ 4yr Stormwater}}$$

Water Captured

$$\text{Extensive Roof} \\ 1,363,622.4 \text{ 4yr} \cdot 0.5 = \boxed{681,811 \text{ 4yr captured}}$$

$$\text{Intensive Roof} \\ 1,363,622.4 \text{ 4yr} \cdot 0.8 = \boxed{1,090,898 \text{ 4yr captured}}$$

Proposed Expansion

$$50,000 \text{ SF} \cdot \frac{623 \text{ gal/in}}{1,000 \text{ SF}} = 31,150 \text{ gal/in}$$

$$31,150 \text{ gal/in} \cdot 14.4 \text{ in/yr} = 448,560 \text{ gal/yr}$$

$$448,560 \text{ gal/yr} \cdot \frac{3.8 \text{ L}}{\text{gal}} = \boxed{1,704,528 \text{ L/yr stormwater}}$$

Water Capturedextensive roof

$$1,704,528 \text{ L/yr} \cdot 0.5 = \boxed{852,264 \text{ L/yr captured}}$$

Intensive roof

$$1,704,528 \text{ L/yr} \cdot 0.8 = \boxed{1,363,622 \text{ L/yr captured}}$$