

March 2014

Reducing the Carbon Footprint of Data Centers

Anqi Tong

Worcester Polytechnic Institute

Carl Kwok Chong

Worcester Polytechnic Institute

Gonul Duren

Worcester Polytechnic Institute

Megan Elizabeth Cann

Worcester Polytechnic Institute

Follow this and additional works at: <https://digitalcommons.wpi.edu/mqp-all>

Repository Citation

Tong, A., Chong, C. K., Duren, G., & Cann, M. E. (2014). *Reducing the Carbon Footprint of Data Centers*. Retrieved from <https://digitalcommons.wpi.edu/mqp-all/537>

This Unrestricted is brought to you for free and open access by the Major Qualifying Projects at Digital WPI. It has been accepted for inclusion in Major Qualifying Projects (All Years) by an authorized administrator of Digital WPI. For more information, please contact digitalwpi@wpi.edu.



WPI

**Integrated
Design Group**

Reducing the Carbon Footprint of Data Centers

by

Megan Cann ECE '14

Carl K.C. Chong ME '14

Gonul Duren CEE '14

Anqi Tong ME '14

3/26/2014

Reducing the Carbon Footprint of Data Centers

A Major Qualifying Project

Submitted to the Faculty of

WORCESTER POLYTECHNIC INSTITUTE

In partial fulfillment of the requirements for the

Degree of Bachelor of Science

By

Megan Cann ECE '14

Carl K.C. Chong ME '14

Gonul Duren CEE '14

Anqi Tong ME '14

Date:

March 26, 2014

Report Submitted to:

Integrated Design Group

Professor Leffi Cewe-Malloy,

Kenneth Elovitz,

Alexander Emanuel,

and Nima Rahbar of

Worcester Polytechnic Institute

Abstract

Data centers use a significant amount of energy and indirectly produce greenhouse gases which have a major impact on the environment. Architecture 2030 is a challenge to new buildings to build 100% carbon neutral buildings by the year 2030. The design achieved by this project can make headway in the right direction. The energy consumption of data centers can be dramatically reduced by implementing modern technology and rethinking the engineering behind traditional data centers. This is achieved by analyzing the traditional data center designs, and determining where the highest energy losses can be reduced and recouped. Techniques implemented include using liquid immersed servers, phase changing material infused building components, Stirling engines, and air-side economizers.

Capstone Design Statement (ME)

A capstone design project is required in the senior year by Worcester Polytechnic Institute. The number one step in fulfilling this is to look into the example building's HVAC (Heating, Ventilation, and Air Conditioning) system and its different components. In order to reduce the carbon footprint of data centers by different methods, different methods are utilized, including liquid-submerged servers, reduced room size, air-side economization, and Stirling engine application to utilize waste heat to generate electricity.

The eight constraints in an MQP include economic, environmental, sustainability, manufacturability, ethical, health and safety, social, and political, and this project addresses most of them, with the exception of manufacturability. The aforementioned HVAC methods have achieved substantial energy saving, and by saving energy, we are achieving the goal to emit less carbon, as well as fulfilling the economic sustainability on saving on monetary spending. Also, carbon emission reduction is beneficial to the environment as carbon dioxide is one of the major greenhouse gases that cause global warming. That can be further interpreted as a benefit to the health and safety to our society because intensified global warming is threatening thousands of lives across the globe. Sustainability is our utmost concern and we hope our endeavors would be proven to be beneficial. Lastly, social, ethical and political concerns are explored by addressing Architecture 2030 goals in our project.

Capstone Design Statement (CEE)

One of the main objectives in this project is to meet the Worcester Polytechnic Institute requirements for senior projects. The Civil & Environmental Engineering Department requires a design element from its students with a Structural concentration in order for them to complete a successful MQP.

In this project, following the principles mentioned, structural members were determined in accordance with building codes. Architectural plans were created for a general idea of the layout following the representative data center space concept.

The number one step in the structural design and analysis of the building was to determine the vertical and lateral loading combinations acting on the structure. Then the roof beams were designed following AISC codes. Then a structural analysis software (STAAD Pro) was used to designate the axial and shear forces, and the bending moments acting on the experimental data center structure. The girders and column sizes were then determined. As our project had a multi-disciplinary theme, the architectural layout has changed several times and therefore caused an iterative process for the structural analysis.

This project addressed most of the eight realistic constraints listed in the ASCE commentary as: economic, environmental, sustainability, manufacturability, ethical, health and safety, social, and political. Environmental and sustainability concepts were explored by the location specific material selection process. Health and safety constraints were addressed by the building codes, ASCE, and AISC provisions for structural safety. Social, ethical and political concerns were explored by addressing Architecture 2030 goals in our project.

Authorship

The academic work of this project will consist of 3/3 unit of work in A - B Term 2013 (September - December) and C term 2014 (January – March). Megan Cann, Carl K.C. Chong, Gonul Duren and Anqi Tong will take credit of the work to be done. The writers of each section are listed below.

Abstract.....	All
Capstone Design Statement (ME).....	Tong, Chong
Capstone Design Statement (CEE).....	Duren
Authorship.....	All
Acknowledgements.....	All
Contents.....	All
Nomenclature.....	Chong
Chapter 1: Introduction.....	Duren
Chapter 2: Background.....	All
2.1: Guidelines.....	All
2.1.1: Architecture 2030.....	Cann
2.1.2: ASHRAE.....	Tong, Chong
2.1.3: Building Codes.....	Duren
2.2: Case Studies.....	Tong, Chong
2.2.1: Facebook Data Center Case Study.....	Chong
2.2.2: Google Data Center Case Study.....	Tong
2.3: Technology.....	Chong
2.4: Architectural Design Considerations.....	Duren
2.5: Liquid Cooling Systems.....	Cann
2.6: Server Power Consumption.....	Cann
2.7: Power Distribution.....	Cann
Chapter 3: Methodology.....	All
3.1: Introduction.....	Duren
3.2: Background.....	Duren
3.3: Defining a Control.....	Cann
3.4: Reductions in IT Power.....	Cann
3.5: Reductions in Miscellaneous Power.....	Cann

3.6: Reductions in HVAC Power	Tong, Chong
3.6.1: Air Conditioning	Tong
3.6.2: Example Data Center versus Experimental Data Center	Tong, Chong
3.6.3: Ictope’s Liquid Submersion Cooling System Server Operating Requirements	Tong
3.6.4: Experimental Data Center Temperature Decision	Tong
3.6.5: Heat Gain and Loss Analysis of Experimental Data Center	Tong
3.6.6: HVAC System with Air-side Economizer Design of Experimental Data Center	Tong
3.6.7: Rooftop Unit and Hot Coil Implementation	Tong
3.6.8: The Stirling Engine and Dry Cooler Cooling System	Chong
3.6.9: Pumping and Piping System	Chong
3.7: Reductions of Carbon Footprint	Duren
Chapter 4: Results	All
4.1: Energy Saving Matrix	Tong, Chong
4.2: Electrical Line Diagram	Cann
4.3: Building Material & Structural Design Results	Duren
4.4: Revit Modeling:	Duren
Chapter 5: Discussion	All
Chapter 6: References	All
Chapter 7: Appendix	All
Renewable Energy Resources	Duren
Case Studies	Tong, Chong
Performance buildings	Chong
A1- Heat Gain Calculation	Tong
A2- Heat Loss Calculation	Tong
A3- Roof Top Unit Selection	Tong
A4 - Hot Coil Performance Data	Tong
A5 - Several Other Ways to Recoup Waste Heat	Chong
A6 - Pipe Heat Loss Calculation	Chong
A7 - Stirling Engine Output Calculation	Chong
A8 - Flow Rate of the Biggest Section	Chong
A9 - Pumping and Piping System	Chong
Structural Design	Duren

Acknowledgements

Several faculty members, students, and our sponsor influenced our work and helped this Major Qualifying Project reach its full potential. We would like to thank our project advisors Prof. Cewe-Malloy, Prof. Rahbar, Prof. Berardi, Prof. Elovitz, and Prof. Emanuel for their interest; their guidance kept us on track from the earliest to the final stage of this project. Receiving immediate feedback maximized our learning experience.

We would like to thank our project sponsor, the Integrated Design Group, for their generous support, their expertise in their field, and correct directions throughout the project. We thank our sponsors for giving the opportunity to visit a data center, enabling us to inspect the environment in order to analyze the concepts better.

Our MQP group would like to take this opportunity to acknowledge every person who assisted us with this MQP in every way they were able to.

Contents

Abstract 2

Capstone Design Statement (ME) 3

Capstone Design Statement (CEE) 4

Authorship 5

Acknowledgements..... 7

Contents 8

Table of Figures 11

Table of Tables 12

Nomenclature 13

Chapter 1: Introduction 14

Chapter 2: Background 17

 2.1: Guidelines 17

 2.1.1: Architecture 2030 17

 2.1.2: ASHRAE 18

 2.1.3: Building Codes..... 18

 2.2: Case Studies 18

 2.2.1: Facebook Data Center Case Study 19

 2.2.2: Google Data Center Case Study 22

 2.3: Technology 24

 2.3.1: Stirling Engine 24

 2.3.2: Cogeneration (CHP, Combined Heat and Power) 25

 2.4: Architectural Design Considerations..... 26

 2.4.1: Raised Access Floor (RAF) and Overhead Cable Tray..... 26

 2.4.2: Construction Material Properties 27

 2.5: Liquid Cooling Systems 31

 2.6: Server Power Consumption 33

 2.7: Power Distrubution 33

 2.7.1: Server Power Management 33

Chapter 3: Methodology 34

 3.1: Introduction 34

 3.2: Background 34

3.3: Defining a Control	35
3.3.1: Power Usage	35
3.3.2: Selecting a Control Server	36
3.3.3: Single Server Power Consumption.....	37
3.4: Reductions in IT Power	37
3.4.1: Server Room Power Consumption.....	38
3.5: Reductions in Miscellaneous Power	39
3.5.1: Room Size.....	40
3.5.2: The Iceotope Solution Layout	41
3.5.3: Lighting.....	43
3.6: Reductions in HVAC Power	47
3.6.1: Air Conditioning	47
3.6.2: Example Data Center versus Experimental Data Center	47
3.6.3: Iceotope’s Liquid Submerged Cooling System Server Operating Requirements	48
3.6.4: Experimental Data Center Temperature Decision.....	49
3.6.5: Heat Gain and Loss Analysis of Experimental Data Center	51
3.6.6: HVAC System with Air-side Economizer Design of Experimental Data Center.....	53
3.6.7: Rooftop Unit and Hot Coil Implementation.....	54
3.6.8: The Stirling Engine and Dry Cooler Cooling System.....	55
3.6.9: Pumping and Piping System.....	61
3.7: Reductions of Carbon Footprint	62
3.7.1: Carbon Footprint Comparison of Some of the Building Materials	62
Chapter 4: Results	70
4.1: Energy Saving Matrix	70
4.2: Electrical Line Diagram.....	71
4.3: Building Material & Structural Design Results.....	74
4.4: Revit Modeling:.....	79
Chapter 5: Discussion.....	80
Chapter 6: References.....	83
Chapter 7: Appendix	85
Renewable Energy Resources	85
Solar Power	85

Biowalls	85
Case Studies	87
Performance buildings	88
A1- Heat Gain Calculation	90
A2- Heat Loss Calculation.....	93
A3- Roof Top Unit Selection	94
A4 - Hot Coil Performance Data	99
A5 - Several Other Ways to Recoup Waste Heat	101
A6 - Pipe Heat Loss Calculation.....	108
A7 - Stirling Engine Output Calculation.....	112
A8 - Flow Rate of the Biggest Section	113
A9 - Pumping and Piping System	116
Structural Design.....	121

Table of Figures

Figure 1: U.S. Electricity Consumption by Sector	14
Figure 2: Carbon Emissions by Sector	15
Figure 3: Architecture 2030 Challenge	18
Figure 4: Facebook Data Center Mechanical and Cooling Design	19
Figure 5: Facebook Open Compute Project	20
Figure 6: Typical vs. Prineville Data Center Power	21
Figure 7: Open Rack Triplet in Prineville Data Center.....	22
Figure 8: Google Data Center Cooling Schematic	23
Figure 9: A Low Temperature Stirling Engine Running on Body Heat	24
Figure 10: IBM Data Center Energy Distribution Flow Chart	25
Figure 11: Liquid Submerged Servers	31
Figure 12: Liquid Cooling Systems	32
Figure 13: Iceotope Server Operating Temperature Requirements.....	32
Figure 14: Block Diagram of Data Center Design	36
Figure 15: Servers Name Plate.....	38
Figure 16: Control Computer Room Floor Plan.....	40
Figure 17: Image of Iceotope Platform	41
Figure 18: Experimental Computer Room Floor Plan	42
Figure 19: Illumination Required by Activity.....	44
Figure 20: Lighting Plan in Experimental Computer Room	46
Figure 21: Equipment Environment Specifications for Air Cooling.....	48
Figure 22: Equipment Environment Specifications for Liquid Cooling	49
Figure 23: Equipment Requirements on Different Liquid Cooling Classes	49
Figure 24: Peaking Cooling.....	50
Figure 25: Peak Heating	51
Figure 26: HVAC System with Air-side Economizer	54
Figure 27: Experimental Data Center Water Flow	57
Figure 28: Infinia 30 kW Stirling Engine System Design.....	58
Figure 29: Infinia 30 kW Stirling Engine System Design.....	58
Figure 30: Dry Cooler From York by Johnson Controls Specifications	60
Figure 31: Example Data Center Computer Room EAT Carbon Emissions Chart.....	62
Figure 32: New EAT Carbon Emissions Chart.....	63
Figure 33: Example Data Center	66
Figure 34: Experimental Data Center.....	67
Figure 35: Live Load Case.....	69
Figure 36: Experimental Line Diagram	72
Figure 37: Experimental Data Center Structural Framing.....	74
Figure 38: Experimental Data Center Structural Analysis.....	75
Figure 39: Girder-Column Connection Design	76

Figure 40: Foundation Design	77
Figure 41: Wall Plan	78
Figure 42: Roof Section	78
Figure 43: Experimental Data Center.....	79
Figure 44: Experimental Data Center CR	79
Figure 45: Internal Loop Liquid Cooling	101
Figure 46: Asetek RackCDU™ with D2C™ Cooled Data Center for Hot Climate	102
Figure 47: Asetek RackCDU™ with D2C™ Cooled Data Center for Temperate Climate	103
Figure 48: Asetek RackCDU™ with ISAC™ Cooled Data Center	104
Figure 49: The Design of a Thermoelectric Device	104
Figure 50: An Ammonia-Hydrogen-Water Absorption Refrigeration System	106
Figure 51: Experimental Computer Room Floor Plan	108
Figure 52: 6 in Pipe Heat Loss Data.....	109
Figure 53: 5 in Pipe Heat Loss Data.....	110
Figure 54: 4 in Pipe Heat Loss Data.....	111
Figure 55: Table relating Pipe Size, Flow Rate, Velocity and Pressure Drop	115
Figure 56: Piping of the Different Modules Schematic	116
Figure 57: Moody Chart	117
Figure 58: Bell and Gossett Series 80 In-Line Pump Performance Curve	120

Table of Tables

Table 1: Comparison of Control and Experimental Servers.....	37
Table 2: IT Power Comparison	39
Table 3: Efficacy of T8 Fluorescents vs. LEDs	45
Table 4: Heat Gain Calculation Results	52
Table 5: Heat Loss Calculation Results.....	53
Table 6: CO2 Footprint Comparison	64
Table 7: Energy Saving Matrix.....	71
Table 8: Structural Members Selected.....	74
Table 9: Foundation Elements	76
Table 10: Flow Rate, Velocity and Pipe Diameter Relationship.....	116
Table 11: Flow Rate, Reynolds Number, Relative Roughness, Friction Factor and Pressure Drop Relationship	118
Table 12: Head Loss of Different Pieces of Equipment.....	119

Nomenclature

Unit Symbol	Name
°C/C	Celsius
°F/F	Fahrenheit
BTU	British Thermal Unit
MBH	Thousand BTU/hr
K	Kelvin
hr	Hour
ft	Feet
sec	Second
lb	Pound
L	Liter
hp	Horse Power
kW	Kilowatt

Chapter 1: Introduction

As the human population continues increasing an exponential rate with increasing access to last century's luxuries which are now accepted by most as necessities, the need for energy will always be on our agenda. However, energy resources are not growing exponentially as our needs. The depletion of non-renewable energy resources, namely fossil fuels, is a global concern. Fossil fuels constitute 81% of the energy currently used, regardless of the fact that these energy resources are likely to last for only two generations at best, as stated in the World Energy Outlook (International Energy Agency, 2012). The usage of fossil fuels creates environmental hazards. Liquid fossil fuels supply 37.9% of total U.S. energy consumption, natural gas 27.3%, and coal 18.6%. According to the U.S. Energy Information Administration, the burning of fossil fuels produces carbon dioxide and other greenhouse gases that are causing the climate change. Thus far, fossil fuels have caused a 29% increase in carbon dioxide emissions since year 2000, as a study conducted by the University of East Anglia suggests. (University of East Anglia, 2009) Figure 1 shows the dependencies according to each sector in electrical energy usage.

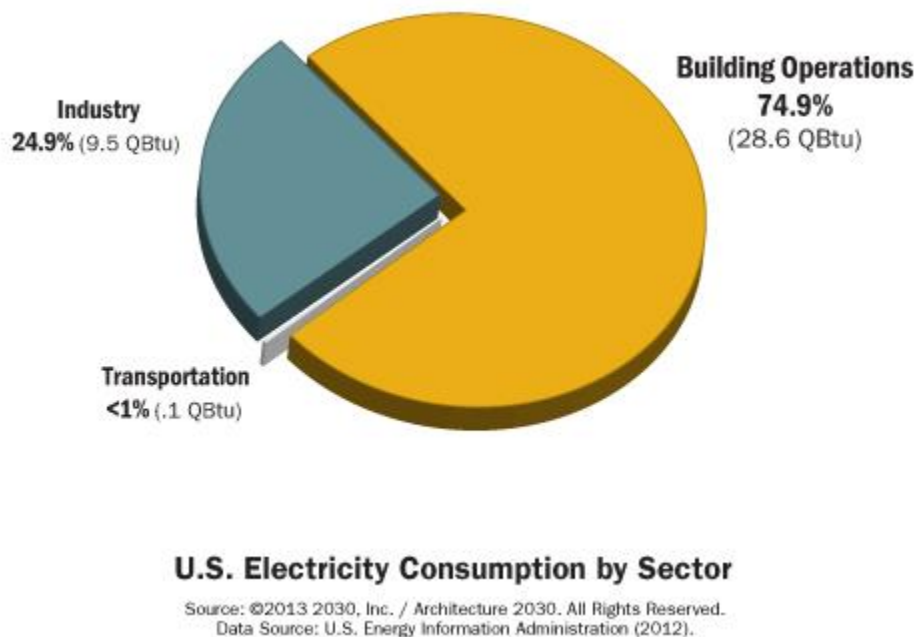

Figure 1: U.S. Electricity Consumption by Sector

Since the fossil fuel usage problem is at this scale, seeking alternative resources to produce enough power for our needs has been extremely necessary. However, since the current efficiency states

of most of the alternative energy producing systems is not enough to power all the current establishments, reducing/conserving the amount of energy used for systems that require the most electricity is a very big step towards becoming environmentally friendly. However during recent decades, the acceleration towards this issue not been as affective as needed. In 2002, architect Edward Mazria established Architecture 2030, a non-profit organization and independent organization, in response to the global warming crisis. The association aims to accomplish a very high rate of reduction in the greenhouse gas (GHG) emissions, mainly of the building sector. Arch 2030 claims that this goal can be achieved by changing the way buildings and developments are planned, designed and constructed. The organization estimates that over the next 30 years (not by 2030), three-quarters of the built environment will be new or renovated based on typical new construction, demolition and renovation trends. Figure 2 which was obtained by the Architecture 2030 website shows the CO₂ emissions by sector for a better understanding of the severity of this issue.

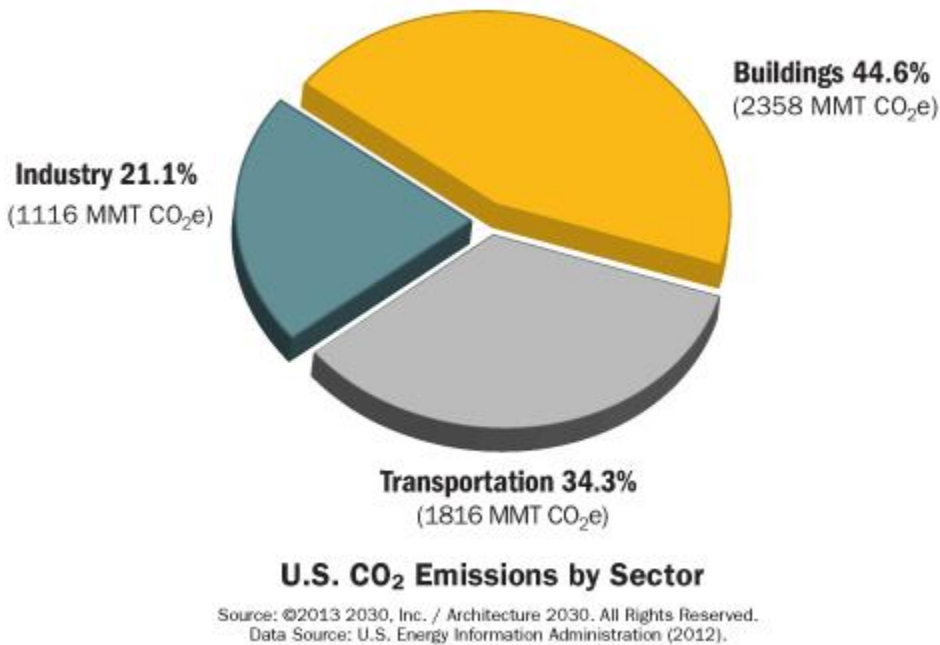

Figure 2: Carbon Emissions by Sector

One of the built environments that use a very high amount of energy primarily for operation and maintenance purposes are data centers. According to a U.S. Environmental Protection Agency (EPA) report, these information storage centers consumed 61 billion kilowatt- hours of power over the course of a year (International Energy Agency, 2012). This amount comprises 1.5% of all power consumed in the

U.S., at a cost of \$4.5 billion (University of East Anglia, 2009). Therefore alternative solutions to make these buildings more efficient are required.

With this in mind, Integrated Design Group (an Architectural Engineering design firm based in Boston that specializes in building data centers) supported Worcester Polytechnic Institute faculty to work with a student research group on the subject. The MQP group mainly focused on reducing the carbon footprint of data centers in an attempt to meet the goals of Architecture 2030. In doing so, an example data center was used for reference. The example data center located in Needham, MA is a three-story building with many components. Our group aimed to define a control center and create an experimental center, by using a single computer room from the example data center (and all supporting systems) and comparing it to an experimental data center completing roughly the same amount of computer “work”. The example and the experimental data centers were compared in terms of carbon footprint emission and energy usage in this project.

Chapter 2: Background

2.1: Guidelines

Several guidelines are followed when building a data center, including Architecture 2030, ASHRAE, and building codes when constructing a building.

2.1.1: Architecture 2030

The goal of the project is to design a carbon net zero data center, and meet the challenge posed by Architecture 2030. Architecture 2030 is an independent organization established in response to global climate change. They have found that the building sector is a major contributor to greenhouse gas emissions, and they have challenged engineers and architects alike to change the way we plan, design, and construct buildings. Fundamentally, the Architecture 2030 goal is to reduce fossil fuel energy consumed by buildings to 0% by the year 2030.

To accomplish this, Architecture 2030 issued “The 2030 Challenge” asking the global architecture and building community to adopt the following targets. First, all new buildings, developments and major renovations shall be designed to meet a fossil fuel, GHG-emitting, energy consumption performance standard of 60% below the regional (or country) average/median for that building type. Second, an equal amount of existing building area shall be renovated annually to meet a fossil fuel, GHG-emitting, energy consumption performance standard of 60% of the regional (or country) average/median for that building type. Third, the fossil fuel reduction standard for all new buildings and major renovations shall be increased to: 70% in 2015, 80% in 2020, 90% in 2025, and Carbon-neutral in 2030 (using no fossil fuel GHG emitting energy to operate). (The 2030 Challenge)

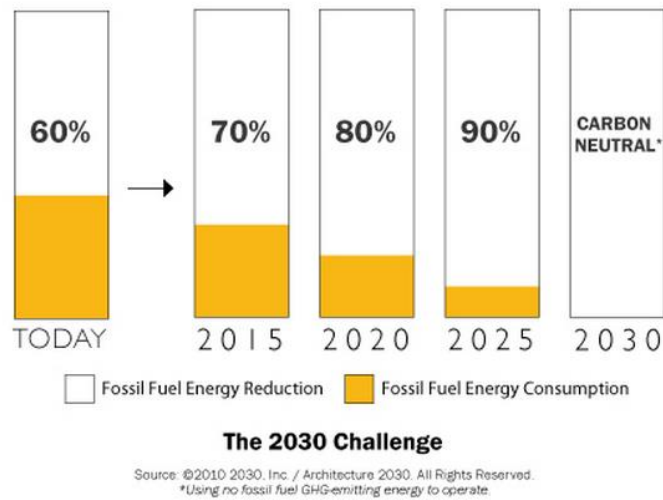

Figure 3: Architecture 2030 Challenge

2.1.2: ASHRAE

The second guideline would be followed when designing data centers is ASHRAE. It stands for American Society of Heating, Refrigerating and Air Conditioning Engineers. According to ASHRAE, There are several factors to consider when designing data centers. Data centers must provide standardized operating environments for equipment, define a common environmental interface for the equipment and its surroundings, and provide guidance on how to evaluate and test the operational health of the data center. They must also provide a methodology for reporting the environmental characteristics of a computer system, guide data center owners and operators in making changes in the data center environment, and provide the basis for measuring the effect of any changes intended to save energy in the data center.

2.1.3: Building Codes

In order to design a data center building that abides by the necessary building codes, the following guidelines were used: International Building Code (IBC) 2009, Massachusetts Amendments to the IBC 2009, and Minimum Design Loads for Buildings and Other Structures by American Society of Civil Engineers (ASCE)-Chapter 7.

2.2: Case Studies

Case studies are important background research because they provide insight on how current data centers are operating.

2.2.1: Facebook Data Center Case Study

Facebook's goal is to build one of the most efficient computing infrastructures at the lowest possible cost. One thing that they decided to do is to design their own software and servers. On the hardware side, their goal is to remove anything in servers that didn't contribute to efficiency.

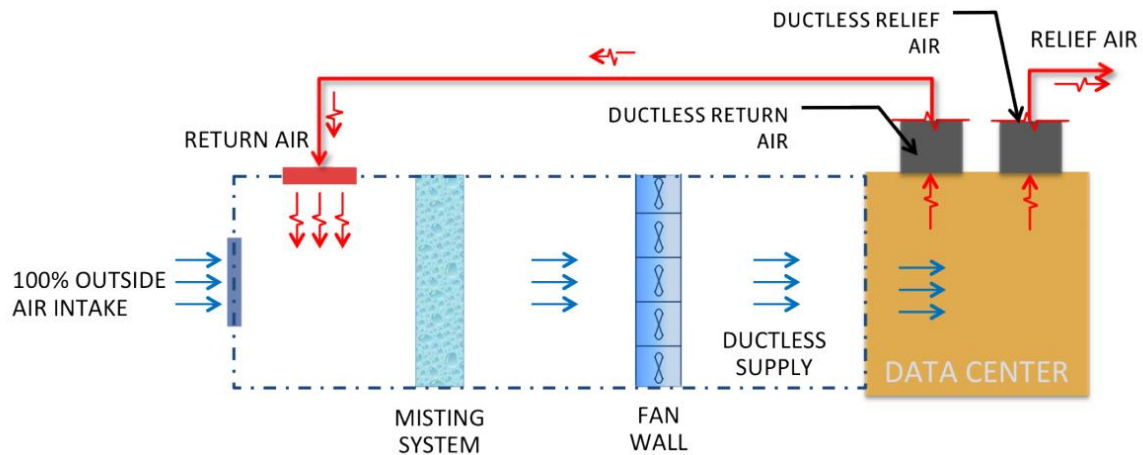

Figure 4: Facebook Data Center Mechanical and Cooling Design

As seen above, there are no chillers or compressors, thus substantially reducing the energy consumption. Ductless overhead air distribution operates at low static pressure, which reduces air leakage and saves energy. The economizer uses direct evaporative cooling and humidification, which reduce the cost on HVAC. (Integrated Design Group, 2013)

Another concept that Facebook has is the Open Compute Project Data Center.

Open Compute Project Data Center

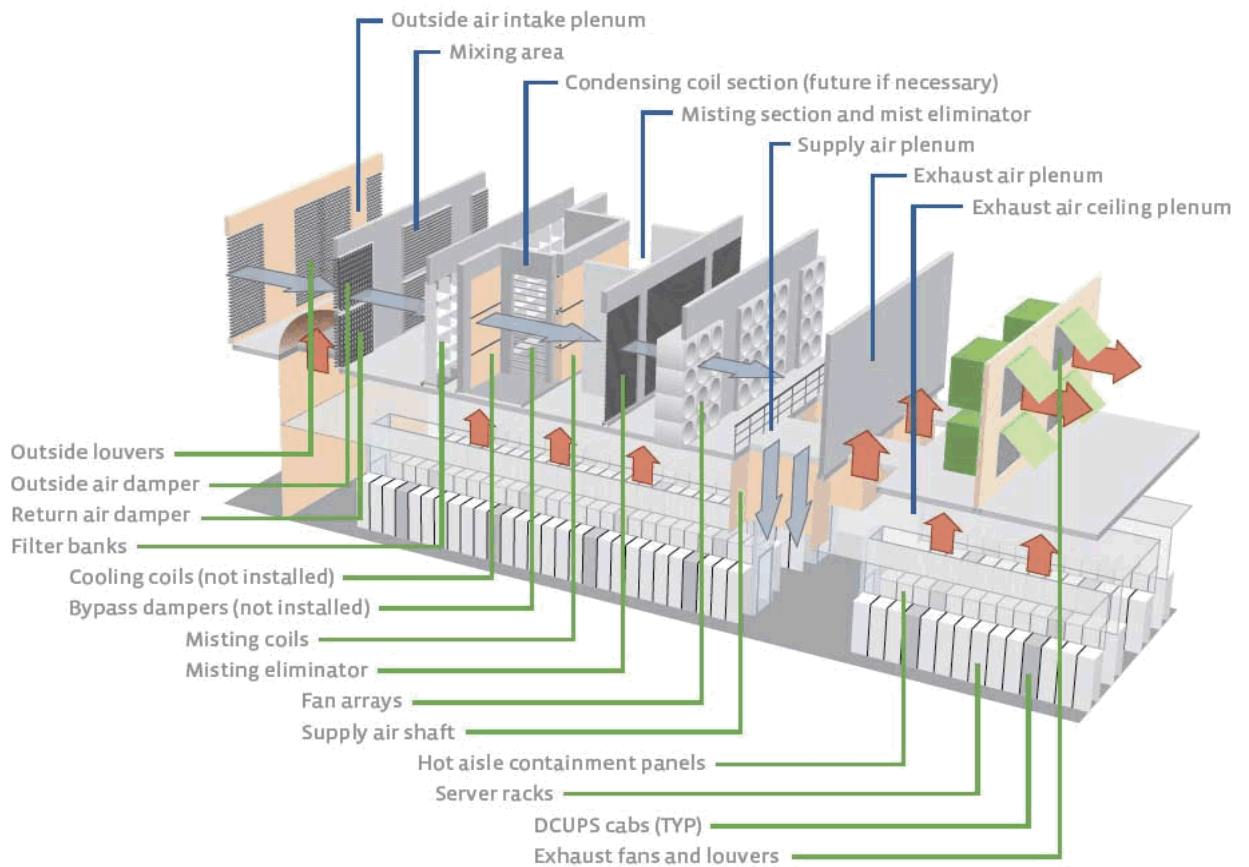

Figure 5: Facebook Open Compute Project

This case study employs a full airside economizer system, which has free cooling from outside air and has its damper situated to reduce moisture issues when cold outside air mixes with moist return air, thus achieving operating cost savings. Besides that, the data center also drives the major equipment VFD, which controls AC motor speed and torque by varying motor input frequency and voltage, optimizing working environment. Other important aspects include high pressure atomization, utilization of onsite well and city water and direct-drive plug (plenum) supply fans.

The Facebook data center is designated as the Prineville Data Center. Below is a comparison of the power usage between the typical data center and the Prineville Data Center.

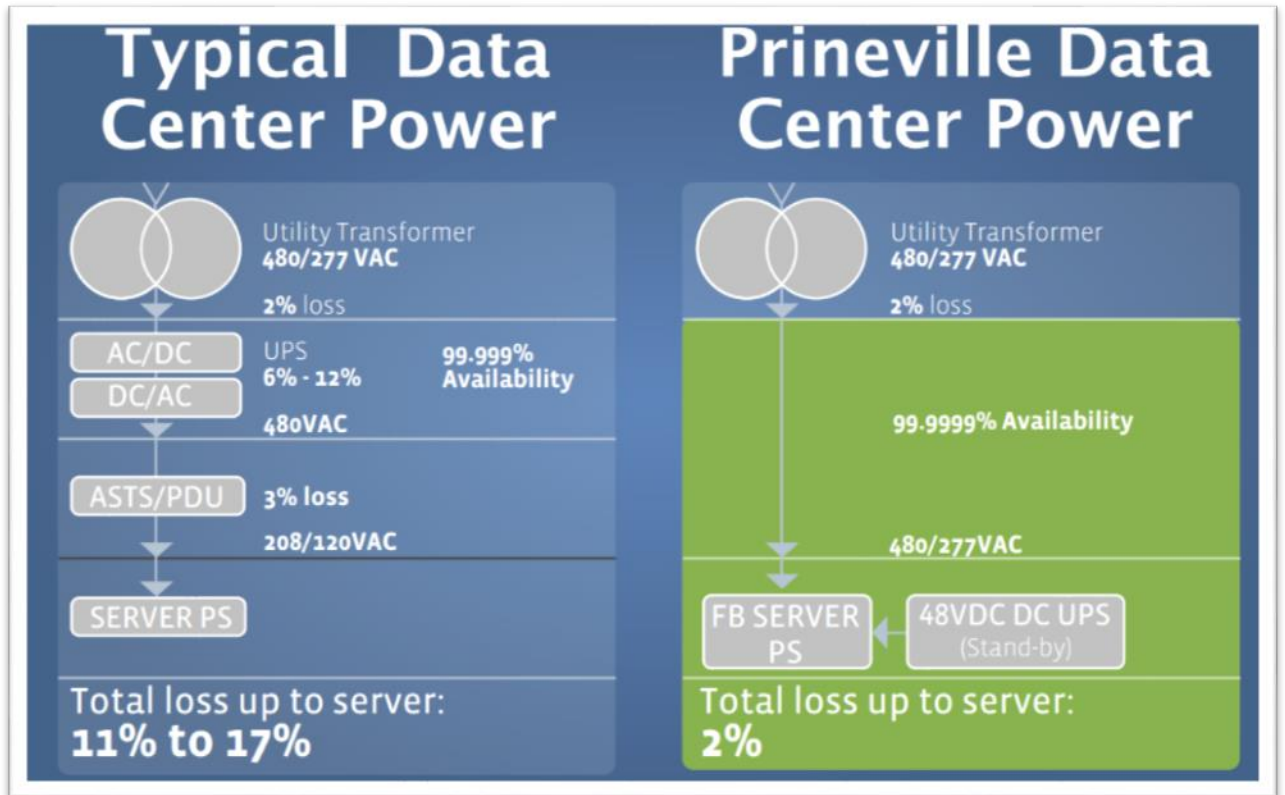

Figure 6: Typical vs. Prineville Data Center Power

The traditional inline UPS (Uninterruptible Power Supply) is eliminated, and the transformation is removed from 480V to 208V, thus eliminated transformation loss. It maintains the 480V distribution centers throughout nonetheless, making it more appealing to data center design.

The organization of the servers of the Prineville Data Center is another aspect examined.

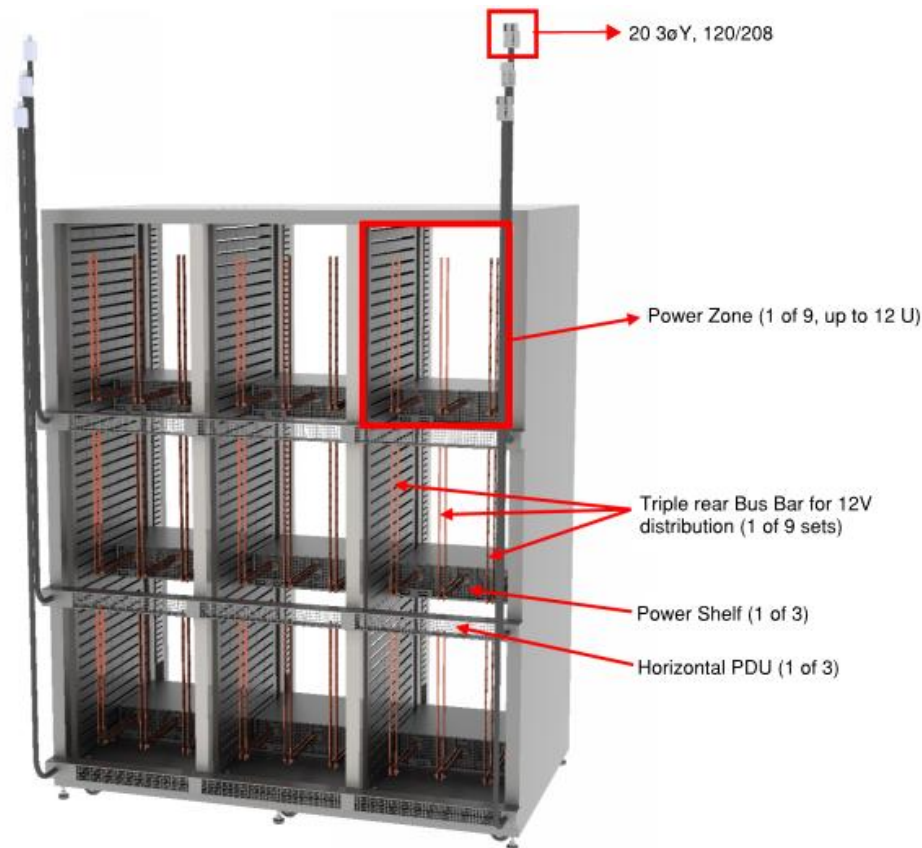

Figure 7: Open Rack Triplet in Prineville Data Center

The Open Rack Triplet deals with the idea of OpenU vs. Standard U. It has three 42U adjoining racks (1U = 1.5in), and each rack holds 30 servers, totally 90. Packing servers together has the advantage of sharing common parts, like power supplies, cooling fans, etc.

2.2.2: Google Data Center Case Study

Besides the Facebook case study, the Google Data Center is another example that is worth noting. Google uses evaporative cooling towers in every data center according (Brandon, 2011). As illustrated in Figure 8, the towers push hot water to the top of the tower through a material, which designed to improve the evaporation performance, and then the water flows down the tower. Some of the water evaporates that draws energy out of the remaining water causing it to cool down. In the meantime, air is drawn through the tower by the fan on top results in carrying away the humidity from

the evaporation. Finally, the cooled-down water is collected at the base of the tower and returned to the data center (Brandon, 2011).

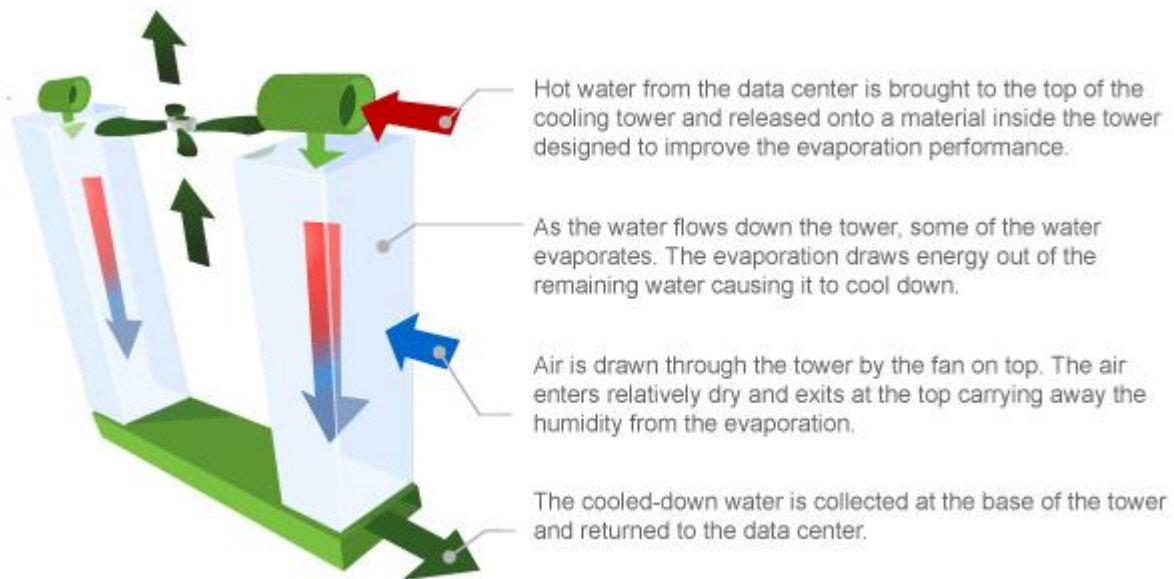

Figure 8: Google Data Center Cooling Schematic

Google opened a data center at the Dalles, Oregon in 2006. The Dalles data center was chosen for its mild climate and access to hydroelectric power. Climates are all different--- some are warmer and wetter, but they rely on evaporative cooling almost all of the time (Brandon, 2011).

2.3: Technology

The team is utilizing the Stirling engine for waste heat utilization purposes, and that method is a variation of a method used in power plants.

2.3.1: Stirling Engine

A Stirling engine is a heat engine that operates on cyclic compression and expansion of air or other gas (the working fluid), and utilizes temperature difference such that they can be converted into mechanical work. It has the potential to be much more efficient compared to traditional gasoline or diesel engine. The reason is because a Stirling engine uses Stirling cycle, which is vastly different from that of internal-combustion engines.

The gas inside a Stirling engine never leaves the engine, and thus there's no exhaust and also that's very quiet. Also the heat source can vary from solar power to gasoline to waste heat generated. One Stirling engine would suffice for our design because implementing too many will be impractical.



Figure 9: A Low Temperature Stirling Engine Running on Body Heat

Running the Stirling engine has several advantages, including the highest theoretical efficiency out of all three options; it is also very quiet when running; and the header system/footer system is very easy to set up, just imagine an electric grid sending electricity from power plants to houses.

However, there are also some drawbacks with the application. It is bulky in size; a 30 kW Stirling engine system that is the largest commercially available product weighs 540 kg. Also it is not self-starting, that means manual start-up is required. It has the most moving parts out of all three options, so it requires more maintenance; also, more moving parts means more friction and misalignment. And the last drawback the application has is the efficiency. The actual efficiency is not so good (in fact, $\eta = 1 - \frac{T_C}{T_H}$

where T_C is cold temperature and T_H is hot temperature), e.g. $\eta = 1 - \frac{298}{373} = 20.1\%$, but it may be solved by implementing a low temperature Stirling engine because it can run on low temperatures, e.g. body temperature or room temperature.

We also looked into the implementation of the thermoelectric device and absorption cooling, and more information can be seen in Appendix A5. The reasoning behind choosing the Stirling engine is because its temperature range is wider than that of the thermoelectric device, and the design of the system is simpler than implementing absorption cooling; also, absorption cooling far exceeds the actual cooling requirements of the experimental data center.

2.3.2: Cogeneration (CHP, Combined Heat and Power)

Cogeneration means generating electricity and useful heat at the same time. An easier understanding of it is that CHP recycles waste heat for future use. Power stations often utilize this technique to further boost the efficiency of the system. A data center is generally on a smaller scale than a power plant, but as shown on the drawings of the control data center, CHP is still considered, depicted as CHP logos (for the future) on the roof schematic. The following picture illustrates the energy usage distribution of an IBM data center. (Oegema, B., IBM 2013)

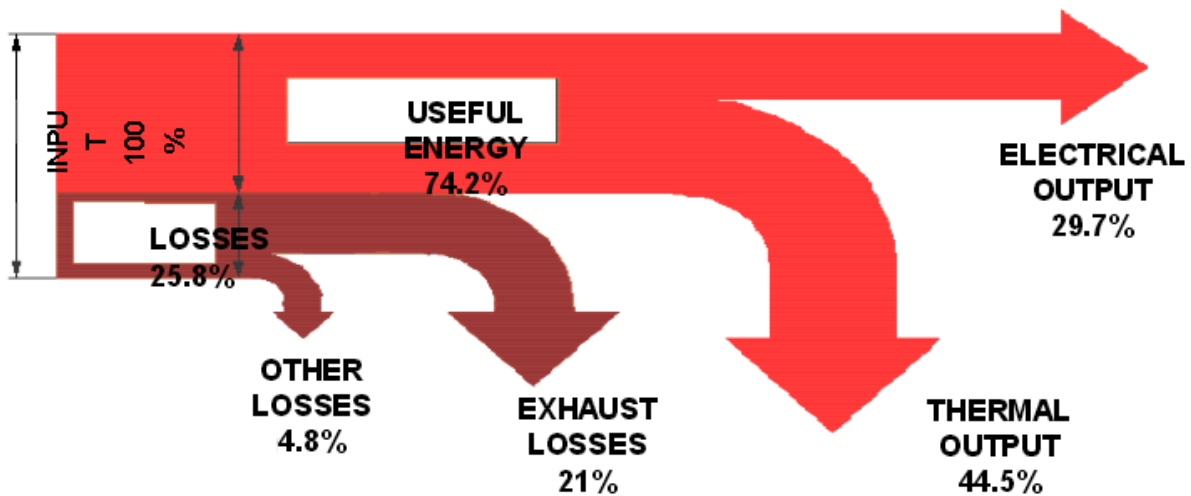

Figure 10: IBM Data Center Energy Distribution Flow Chart

2.4: Architectural Design Considerations

2.4.1: Raised Access Floor (RAF) and Overhead Cable Tray

One of the main design considerations for a data center server room's air handling and cabling distribution systems is the decision of using whether RAF, overhead cabling, or a combination of both. RAFs are usually constructed by using gridded metal framework that provide liftable floor panels. The framework usually consists of steel-clad particleboard or a steel panel with a cementitious core and can be covered with various finishes. The space underneath is usually at least six inches and typically higher to provide enough space for cabling and airflow. Overhead cable trays, on the other hand, suffice room for ductwork and cables by organizing their flow.

RAF Pros:

- Precise airflow management
- Aesthetic integrity

RAF Cons:

- More material
- Costly
- Structural problems may occur (Rocking panels, gaps between panels)
- Reduces the interaction between the heat gains and the thermally massive concrete slab

Overhead Cabling Pros:

- More economical
- Material savings

Overhead Cabling Cons:

- Life safety concerns during repairs
- Not aesthetical

Traditional servers require a certain airflow management to perform correctly. In order to achieve this principal, instead of supplying cooled air to the whole room with an air conditioning unit, it is more reasonable to allocate isolated airflow zones by making use of RAFs. Overhead cabling cannot play a role in this direction other than to further alter the air-conditioning. Therefore the economical question at hand seeks for a comparison between the direct initial construction cost of the RAF system and the indirect operational cost of overhead cabling units.

2.4.2: Construction Material Properties

In order to achieve the goal of Architecture 2030 and reduce the carbon footprint of data centers, or buildings in general, a careful selection of building materials must be made. In order to make a selection of these materials, a lot of options' features must be considered.

2.4.2.1: Conventional Structural Materials

The choice of materials used in the making of a structure immensely affects the finances, durability, construction time and the feasibility of the project. Therefore the decision on the design materials must be made with great care, following the building codes. There are currently three common materials that could be used for the purposes of this project:

Wood

From the constructability perspective, due to its rather light weight feature (35 lb/ft³ density for lumber), wood is very easy to work with for lifting and hoisting purposes on a construction site. Another benefit of wood being lightweight is that it highly decreases the dead-loads, which is generally a desired quality for structural goals. On the downside, since the shaping of material is fairly harder than its opponents, the residue amount after cutting and shaping wood is also higher. This may be reflected as something that makes the material harder to construct with.

Amount of time it takes to construct a wood building may be considered smaller than the other options because of its lower density and the easiness that creates at a construction site. The cost of structural wood materials fluctuate and also vary greatly from country to country; or even, state to state. This mainly originates from the amount of natural sources available to that specific area. In general, places with a high population density and/or a low available wood resource amount tend to avoid the use of this material. However, New England region has both those qualities reversed, with a rather low population density and a considerably huge amount of wood resources.

Wood is a good thermal insulator (0.179-0.22 BTU*ft/h*ft²*F R thermal conductivity, R value) and this can be considered an advantage to its already rather low costs since using a good insulator as the structural material can help in cutting from the extra insulation costs.

On a separate note, it would be fitting to mention that wood is the material with the quickest renewability span among the three options. This feature gives it an environmental boost; however, the fact that due to overpopulation and lack of care most of the material being used doesn't get the same rate of return may shadow this quality. Its carbon footprint varies between 0.841-0.93 lb/lb. Wood is

also a highly flammable material and this feature must be factored in for design purposes especially in environments with an adverse fire incident rate.

Even though wood is not a material that is typically suitable for a data center building due to its high combustibility, it was researched for educational purposes in order to better compare with other materials.

Steel

Steel is considered to be the most important ferrous metal due to its high strength (50-84.1 ksi-tensile). It is widely used as a structural building material, mostly in long-span structures such as bridges and skyscrapers. As for constructability purposes, steel stands out with its weldability that allows it to be shaped, bent and made into many different other components which are not necessarily structural. On the other hand, steel's high density (487-493 lb/ft³) causes it to be harder to lift and carry for the constructability purposes.

The time it takes to build with steel depends greatly on whether the steel is being fabricated off-site before the construction process starts or not. As is always the case, pre-ordering steel in the desired size from the manufacturing plant helps immensely for cutting from the construction time.

Cost of steel has been reported to be on a rise for the last two decades. By the CES-Edupack 2012 Edition, a pound of steel is stated as 0.303-0.334 USD/lb. On the other hand, steel is not an insulator, instead it is a very good conductor, and this may cause a certain amount of increase in its price when the insulation costs are factored in. Another point that increases the steel cost is its need to be fireproofed. Structural steel's recyclability rate is very high, making it environmentally more friendly. On average, 1.8 tons of CO₂ is emitted for every ton of steel production. Steel industry has reduced the energy consumption it caused by 50% over the past 30 years (World Steel Association, 2012). However this also brings up the question of how much more efficient can steel be made, since the major reduction has already taken place.

Concrete

Concrete is a complex composite and a very strong material with a very high compressive strength value. However it is very weak under tensile stress (0.145-0.218 ksi). Since a concrete building construction requires the concrete to be made only up to 3-4 hours earlier at a maximum before placing it on the site, the process must be precise. If mixing concrete is not going to be available on-site, this can cause a big problem when the mixing process is not at a close location.

Moreover, using concrete for construction under winter circumstances may be beneficial since the material is exothermic (releasing heat). However, it can also have adverse effects depending on how severe the weather conditions are.

Time-wise, using concrete with a 2-day cycle in constructions is considered to be a great way to save time. It is said that it can cut the building process in half in comparison to that of a steel construction. The swift process of construction reflects greatly on the cost of building a structure with concrete, since a much less labor will be required. The cost of the material itself depends greatly on the water-cement ratio as well as the portion of coarse aggregate being used. Price stated in CES-Edupack 2012 Edition per 1 lb of concrete is 0.0188-0.0282 USD. The price of concrete has stayed relatively stable when considered in comparison with other construction materials such as steel and wood. For every ton of concrete produced, 0.9 tons of CO₂ is emitted into the environment (Mahasenan, Smith, Kaya, & Humphreys, 2003).

Due to the high emission rates of CO₂ during cement production, concrete is the third largest contributor of carbon dioxide in the United States (Biello, 2008). The fact that this high rate results from the manufacturing process of Portland cement is promising since this material has innovative substitutes that have lower CO₂ production rates.

2.4.2.2: Innovative & Green Building Materials

Liquid Granite

Liquid granite can be used to completely replace cement in concrete. Since during the reduction of limestone into lime and combustion of fuel (typically coal) during the creation of cement causes the release of a great amount of carbon into the atmosphere, it is necessary to find alternatives. Liquid granite has almost the same load bearing capacity of cement if not more, and is made of recycled materials.

Liquid granite has none of the environmental impacts that cement and conventional concrete do. It is made up of between 30 and 70 percent recycled industrial waste material, and uses less than one third of the cement used in precast concrete, therefore it has a highly reduced carbon footprint to a rate of about 35% (Mangat, 2012). This material can be used as a substitute for cement in order to make pre-cast concrete panels, which may highly reduce the initial carbon emissions of the construction.

Geopolymer Cement

Again, as opposed to Portland cement, geopolymer cements don't require calcium carbonate and therefore generate about 40-90% less CO₂ during the manufacturing process (Davidovits, 1993). Slag-byproduct, rock-based, and fly-ash based cements are the most popular types of the geopolymer cement category. Within this category, slag-byproduct seems to be the most efficient for CO₂ reduction with a decreasing rate of up to 90%. This material can be used to completely replace the Portland cement in the concrete panels, which will result in a significantly high carbon footprint emission decrease.

Recycled Steel

According to the Steel Recycling Institute (SRI), builders are simplifying the framing process by ordering customized steel beams and panels to fit each specific design. The SRI touts the durability of steel in areas subject to high winds and earthquakes. Further, it reports that while a 2,000-square-foot (186-square-meter) building requires 40 or 50 trees to build, a frame from recycled steel would require no more than the material that comes from six scrapped cars.

Phase Changing Material (PCM) Infused Components

PCM is a substance that is capable of melting and solidifying at a certain temperature on a cellular level while storing and releasing a very large amount of energy. Basically, the heat is absorbed when the material goes from solid state to liquid state. Such quality could be benefited from for relieving the stress on the HVAC system. Via encapsulating the PCM in the building materials to be used, the excess heat could be absorbed and then reused when needed. Encapsulation is a crucial point in order to prevent the building materials from deteriorating due to the chemical effects of PCM. Macro-encapsulation proved inadequate namely because of the poor conductivity aspect it caused. As PCM started to regain its heat, it would solidify around its edges, preventing effective heat transfer. Therefore microencapsulation is being used nowadays instead. Since the dimensions with the latter option are so small, the heat transfer is not adversely affected at all (Castellon, 2007).

There are several ways to benefit from PCM in a building environment by incorporating it into the main materials. One of the solutions is to mix PCM in concrete, which in many cases decreases the structural loading capacity of the material. However for non-load bearing elements, this would be a good option. Another way to utilize PCM is to incorporate it in the insulation material, or on the drywalls. The BASF company based in Germany is the leading producer of PCM related building materials, and the firm claims that up to 50% efficiency can be achieved through using their products

correctly. This indirect 50% efficiency in carbon footprint production is claimed to be accomplished by the reduction in electricity usage that results from the incorporated PCM.

2.5: Liquid Cooling Systems

Iceotope and Green Revolution Cooling use two different methods for liquid submersed cooling. In these systems, there is no air exposure to the electronic components at all. In both systems, the servers are submerged in a dielectric liquid which has the following properties: non-flammability, low toxicity, high heat transfer capabilities, and high dielectric strength. This means that the liquid is nonconductive, and the heat generated by the servers efficiently transfers to other water based cooling systems. This method of computer cooling is independent of the outside environment, and ideal for “hostile” environments. These systems are also independent of the ambient air temperature and the air humidity. (Iceotope Servers Offer Full Time, Free Cooling For Cloud Services)



Figure 11: Liquid Submerged Servers

The Green Revolution Cooling system uses large 42U tubs (usually set up in a group of 4) filled with their particular dielectric fluid to cool each directly submerged server. This coolant is pumped to a heat exchange (coolant-to-water) and filtered. The water used in the heat exchange can fall between 30 and 53 degrees Celsius. One advantage to this system, is that the client can choose any server they desire, assuming they fit the minimum specifications.

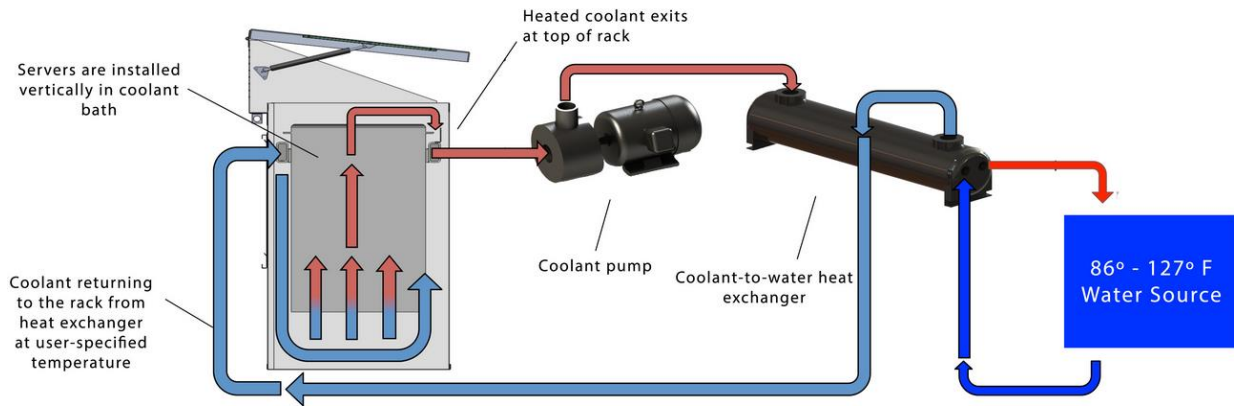

Figure 12: Liquid Cooling Systems

The Iceotope system integrates each server individually within a capsule of coolant and becomes a “module”. Each server platform holds 48 modules, and the platform contains an imbedded water cooling system. Each module is fed water less than 45 degrees Celsius and the output water is less than 50 degrees Celsius. This system is unique because it is designed to be fully recyclable. There are no plastic components, and all modules have a 5 year life cycle. The platforms and the coolant each have a 15 year lifecycle.

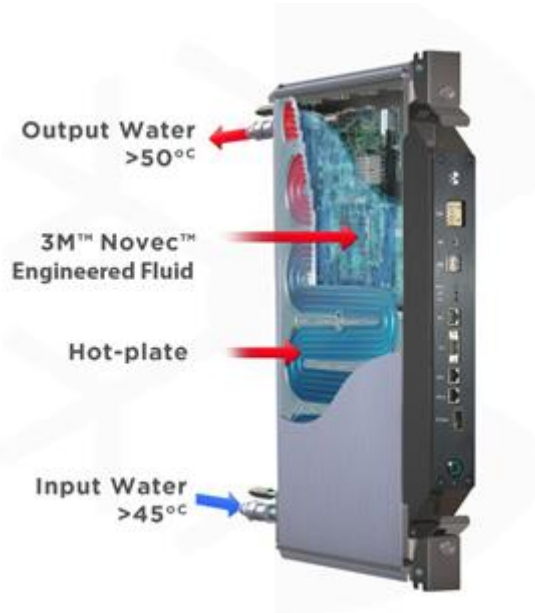

Figure 13: Iceotope Server Operating Temperature Requirements

2.6: Server Power Consumption

While there are multiple types of servers, (proxy servers, mail servers, web servers, etc.) all servers contain the same core components. Every server must contain a processor, RAM, memory, and a power supply. The type of server is defined by what job it is performing, and these jobs define what the internal configurations must be. As technology advances, the market focuses on getting more for less. Consumers ask for higher processing power, faster reactions speeds, and more storage space, and all in less space than the previous design. The relationship between processor power, RAM, and memory is proportional to their power consumption. The client is entirely responsible for filling the data center with servers as well as or what purpose the servers should be configured for, but the data center design needs to be able to handle servers under maximum load conditions.

2.7: Power Distrubution

To transmit large quantities of power over long distances, commercial power is sent at high voltages. Medium voltage is loosely defined by Siemens as anything above 1kVac to 38kVac. At each building, transformers are required to step down the power into voltages that are usable by various appliances. However, the Uninterruptable Power Supply (UPS) used in server power distribution end up “double converting” these voltages from Alternating Current (AC) to Direct Current (DC) and back to AC again. Servers require a UPS to generate a clean, consistent waveform and to isolate the equipment from the external power source. This double conversion causes losses, which can be avoided with “line interactive” or “passive standby” UPS systems. Unfortunately, these methods of power distribution do not fully protect the IT equipment from power fluctuations and may compromise server protection.

2.7.1: Server Power Management

While this will not be investigated in full detail in this project, it is important to note a few more methods for increasing the efficiency of the servers. Companies like Intel, Supermicro, and AMD are always developing their chips to be as energy efficient as possible, and consumers will traditionally pay a higher price for this premium. The same is true for power supplies. In addition, companies that design power supplies for data centers are aware that power distributions and loads vary according to the application of the servers. Servers configured for virtualization will run on less power than servers doing hard computing. These companies suggest that the power supplies be configured to these specific applications to increase the efficiency of the overall computer. Lastly, on the occasions where processors have lower loads, we can enable entry into Low Power Modes, which decreases the power usage but sometimes increases the response times of the servers.

Chapter 3: Methodology

3.1: Introduction

This section introduces the planned tasks of the team in order to meet the MQP guidelines and the IDG requirements. Alternative energy-efficient electrical, HVAC and structural designs to the firm's previous data center buildings were created using software such as Revit, STAAD Pro and AutoCAD.

3.2: Background

The background for the students' design strategy for each discipline primarily included the drawings offered by the IDG, site visits to operating data centers, research on previous applicable energy-efficiency methods and interviews with former designers. The drawings provided by the firm supported us in establishing a primary understanding in how the final designs could be presented. While the final student generated drawings might not be as detailed as the original drawings, they are planned to provide sufficient insight on our innovative design solutions. The site visits were very helpful in acquiring additional information about details that could have been missed in initial research period. The group has toured the WPI data center and another data center that was built by the company. Our research on the previous energy-saving methods aided us in keeping our project up to date. Interviews with the IDG engineers and architects would be very helpful in understanding the decision-making process during the design and construction of the data centers built by the firm. The final design for the MQP required calculations and modeling in all three engineering aspects to meet each department's capstone design requirements; namely electrical, civil (structural), and mechanical. Weekly meetings with the advisors provided our team with constructive feedback and helped the project in being carried out as planned.

3.3: Defining a Control

In order to properly assess how much of an impact our design will have, we need to develop a control as a comparison point. Integrated Design Group has supplied electrical, mechanical, and architectural drawings of an example data center to serve as our traditional data center.

Most of what goes into a data center is client specified. Considerations such as potential office space, security, number of computer rooms, etc., can dramatically change the energy usage and carbon footprint of the building. For this reason, we are analyzing a single computer room within the example data center and all of the systems necessary used to run only that room. This study does not include all of the additional rooms, office space, and other extraneous rooms and floors in order to simplify create a more direct comparison.

3.3.1: Power Usage

The power usage is broken down into categories. As power comes in from the grid, it can be used one of three ways: heating, ventilation, and air conditioning systems (HVAC), information technology systems (IT), and miscellaneous systems (such as lighting, outlets, etc.). In a traditional data center, all of this power is purchased from external utilities. In the new design, the HVAC component will be able to reuse energy IT expends as heat and reduce the amount of energy required from the grid.

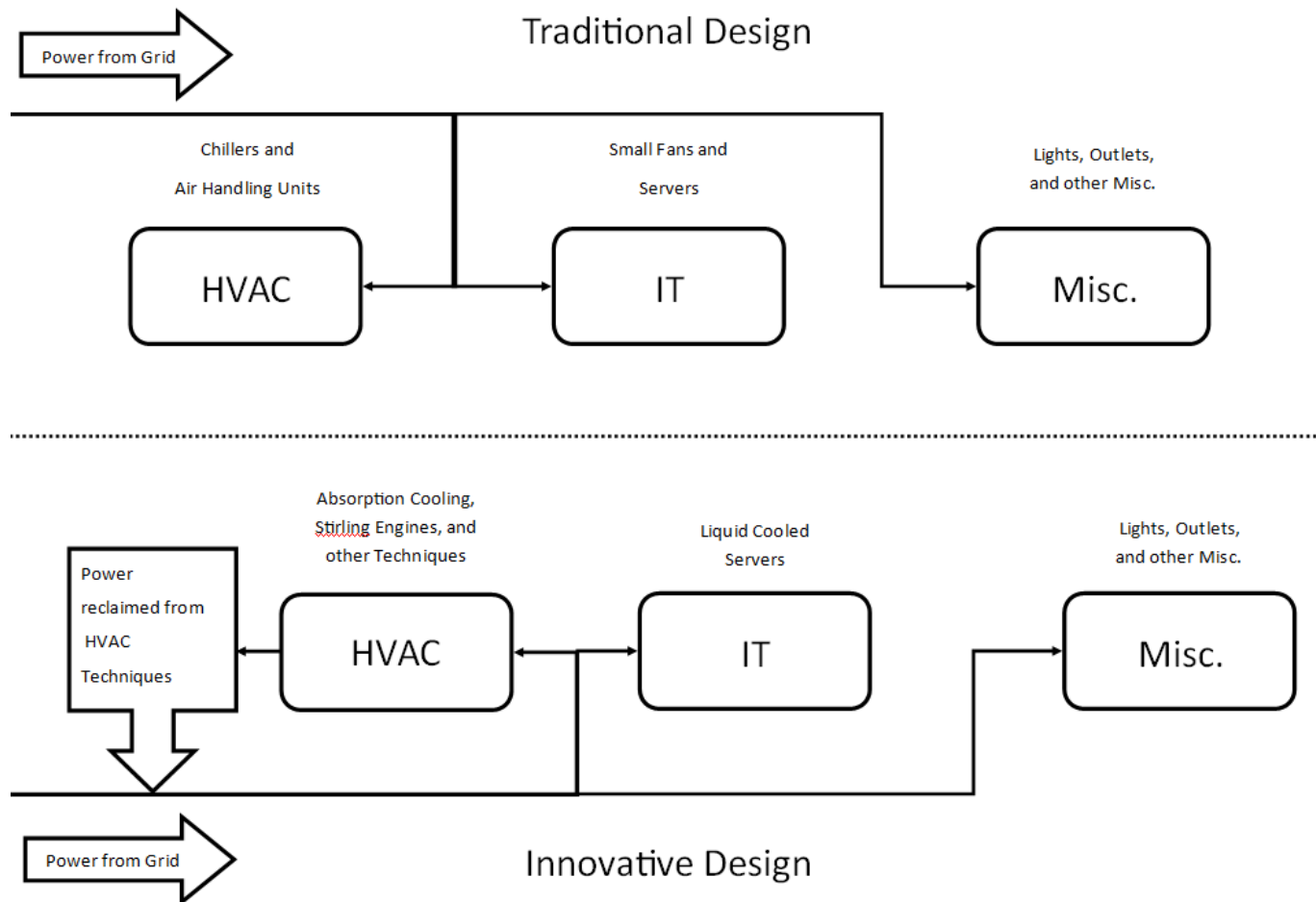

Figure 14: Block Diagram of Data Center Design

3.3.2: Selecting a Control Server

To properly compare the efficiency of the Iceotope servers, the Dell R720 Xeon High Performance server was selected as a basis of comparison. This server makes a good choice for a control because it is customizable to fit user requirements, has variable power supply ratings, and is a common choice for data centers. The Dell R720 has various power supplies that it is compatible with. A power supply rating represents the maximum load that the power supply would be able to supply to a given server configuration operating at maximum capacity. For the prototype data center, we are assuming that the computers are using virtualization techniques such as cloud computing to maximize the use of each server at all times. It is important to design for the worst case scenario and assume maximum loads

and maximum power consumptions when designing a building that must conform to fire protection standards. This gives the hard limits which must not be exceeded, and operating under these assumptions allows us to maximize the number of servers we can safely house.

3.3.3: Single Server Power Consumption

The Dell R720 and the Iceotope Module each have various but comparable configurations. With this in mind, we’ve taken the configurations in the Iceotope Modules and maximized and matched the components in every available respect. (Iceotope Servers Offer Full Time, Free Cooling For Cloud Services)

	Dell R720	Iceotope
Processors	Two Intel® Xeon® E5-2650 2.00GHz, 8C, (8 Cores)	Two Intel Xeon E5 (Romley) Processors with 8 Cores each
RAM	16GB RDIMM, 1600MT/s, Low Volt, (16 of them)	256 GB of DDR3 ECC Registered RAM per module
SSDs	300GB Solid State Drive (2 of them)	Two 300 GB Intel 710 Series High Endurance SSDs
Power Supply	750W	400W

Table 1: Comparison of Control and Experimental Servers

In this comparison, the Iceotope module is built to its maximum possible configuration. Under no circumstances will the 400W power supply be insufficient to power the full configuration of the Iceotope module running on a full load. The Dell R720 is matching the Iceotope Module, but in some categories could be configured with faster processors or more RAM. For this reason, a Dell R720 can be configured with a 495W, 750W, or 1100W power supply. In this case, Dell advises the 750W power supply would be the minimum to power the above configuration under maximum load.

3.4: Reductions in IT Power

One of the most significant changes we are going to make to the data center is the type of servers that are to be used. As discussed in the background section, the prototype data center will implement liquid immersed servers. Specifically, the experimental data center will use the Iceotope Solution.

3.4.1: Server Room Power Consumption

Based on the control drawings, we know that the connected service load sent to the servers through the UPS is 1125kW.

CONNECTED SERVICE LOAD		
UPS (2 x 625KVA)0.92 EFF	=	1359KVA
CHILLER CHA 491.6KW @ 0.9PF	=	547KVA
CHILLER CH R1 (1/2 LOAD)	=	274KVA (NOTE 1)
M4A/M4B (2N DESIGN)	=	205KVA
P4A/P4B (2N DESIGN)	=	145KVA
TOTAL	=	2530KVA
AT 480V	=	3048A

NOTE:

1. REDUNDANT CHILLER LOAD WILL BE DEMAND LIMITED IF SWITCHBOARD LOAD APPROACHES CAPACITY.

UPS DESIGN BASIS	
A.	2N REDUNDANT UPS.
B.	MAXIMUM UPS CURRENT DRAW:
	1. 100% OF MODULE RATING
	2. MAXIMUM BATTERY CHARGING IS 15%
	3. UPS CAPACITY IS 1125KW/1250KVA

Figure 15: Servers Name Plate

Knowing the minimum power required to supply each server safely, and knowing the maximum power delivered to IT in the control data center, we can determine the maximum number of servers the electrical infrastructure can handle in the control data center.

$$\frac{IT \text{ Power to Computer Room}}{\text{Maximum Power Consumed per Server}} = \text{Number of Servers Powered}$$

Equation 1: Number of Servers Powered

In the case of the control computer room, IT Power delivered is 1125kW, Maximum Power Consumed by each control server is 750W, therefore 1500 Dell R720 servers can be safely operated in the room. The purpose of this project is to reduce the carbon footprint, without changing how much computational output the building produces. So, we rearrange the equation in the prototype computer

room, to determine the IT Power needed to run the same amount of servers, and provide the same amount of work.

Maximum Power Consumed per Server × Number of Servers = IT Power to Computer Room

Equation 2: IT Power to Computer Room

The Maximum Power Consumed by each Iceotope module is 400W, there are 1500 Iceotope modules in the room, therefore the total Maximum IT Power required by the new computer room is 600kW.

	Traditional Data Center	Innovative Data Center
Number of Servers	1500	1500
Power per Server	750 W	400 W
Total Power Consumed	1125 kW	600 kW
IT Power Reduction	0% (Control)	47% Reduction

Table 2: IT Power Comparison

The major reason for why the power per server is significantly lower than the control, is that the Iceotope Solution is catered very specifically to a limited number of options. This allows for closer load matching, which increases the efficiency and decreases the requisite power. When selecting for R720 configurations, there are 15 or more categories in which there are 5 to 25 options. This leads to a huge variation in calculating minimum power supplies, but Dell only offers the 495W, 750W, or 1100W power supplies. Consequently, by making the switch to the Iceotope Solution, the Maximum IT Power required is reduced by 47% when under best case conditions.

3.5: Reductions in Miscellaneous Power

When designing a building, the engineers must consider building codes. There are basic systems that every building must contain to meet various safety standards. Systems such as fire alarms, outlets, lighting, etc., affect the total building power. In a data center, the power used to run these miscellaneous functions is very small in comparison to the energy required for IT or HVAC. However, there are still methods we can explore to reduce this amount of power.

3.5.1: Room Size

In traditional data center design, the size of the room is heavily dependent upon how many servers will be inside. The total IT power sent to the room can tell us how many servers can be powered, but the density of the servers (measured in kW/rack) dictates the placement of these server racks. The general “rule of thumb” with air cooled servers is that you do not want to exceed 6-8 kW/rack. Increasing the power density in this respect leads to overheating unless additional HVAC methods are employed in the room. Additionally, one must provide ample space in the front and rear of the servers where the air intakes and outputs are. With this information, we can draft an example layout of the control computer room.

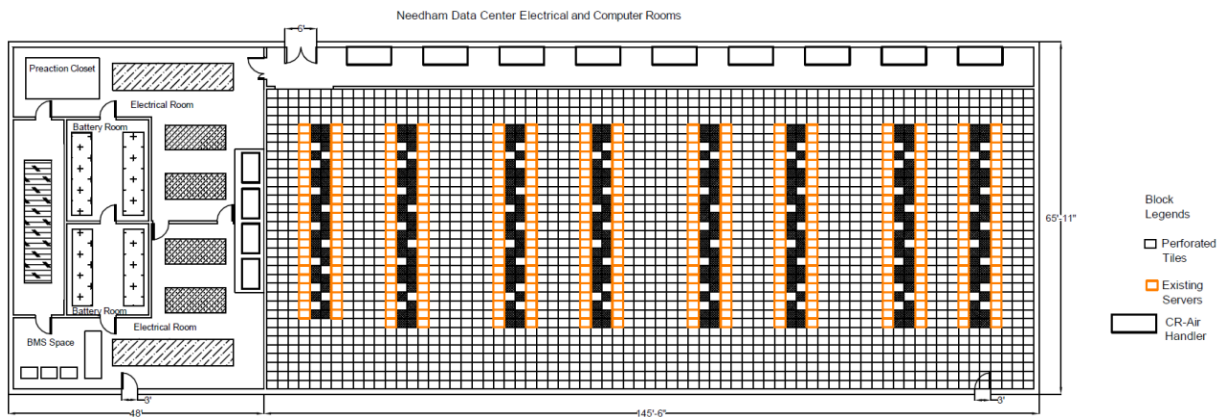

Figure 16: Control Computer Room Floor Plan

The provided architectural drawings indicate that the room is approximately 17.7 x 44.5 m, which gives an area of 788m². Each small square indicates one server rack. Considering the maximum power density is 6-8kW/rack, and each of our servers requires 750W, we can design the layout using a power density of 7.5kW/rack.

$$\frac{7.5 \text{ kW per Rack}}{750 \text{ W per Server}} = 10 \text{ Servers per Rack}$$

Equation 3: Servers per Rack

In the server rack industry, the term 10U would indicate that this particular rack can hold up to 10 servers (or units).

$$\frac{1500 \text{ Servers per Room}}{10 \text{ Servers per Rack}} = 150 \text{ Racks per Room}$$

Equation 4: Racks per Room

An average 10U server rack has the dimensions 0.5 x 0.45 x 0.6m (length, width, height). With 150 10U racks, the consumed area will be 33.75m² of the total 788m² in the room.

$$150 \text{ 10U Racks} \times \text{Area of Each Rack} = \text{Floor Area Used by Racks}$$

Equation 5: Floor Area Used by Racks

If the area of each rack is 0.225m², then the floor area used by racks will be 33.75m² of the total 788m² in the room.

At first glance, this seems like the size of the room is far larger than it needs to be. The reasoning is that every watt of power that is spent on IT, is turned into heat. The air-cooled servers require large amounts of air to be circulated throughout the room in order to properly cool the servers.

3.5.2: The Iceotope Solution Layout

The most important factor when considering the traditional room layout is the power density and access to adequate air intake and output. With the Iceotope Solution, the only limiting factor is the physical size of the server platform, and the adequate piping of water.



Figure 17: Image of Iceotope Platform

In the Iceotope Solution, the server is called a module, and the server rack is called the platform. Each platform can hold 6 module centres, and each module centre holds 8 modules. Consequently, the Iceotope Platform contains as many servers as a 48U server rack. By using liquid imersed servers, the power density is not limited to 6-8 kW/rack.

$$48 \text{ Servers/Rack} * 400\text{W/Server} = 19.2\text{kW/Rack}$$

In this case, the platform is 19.2 kW/rack. Additionally, we no longer need to reserve space in the front and the rear of the racks. In the Iceotope Platform, only the front of the each server is accessible without removing the module from the slot. (Iceotope Servers Offer Full Time, Free Cooling For Cloud Services)

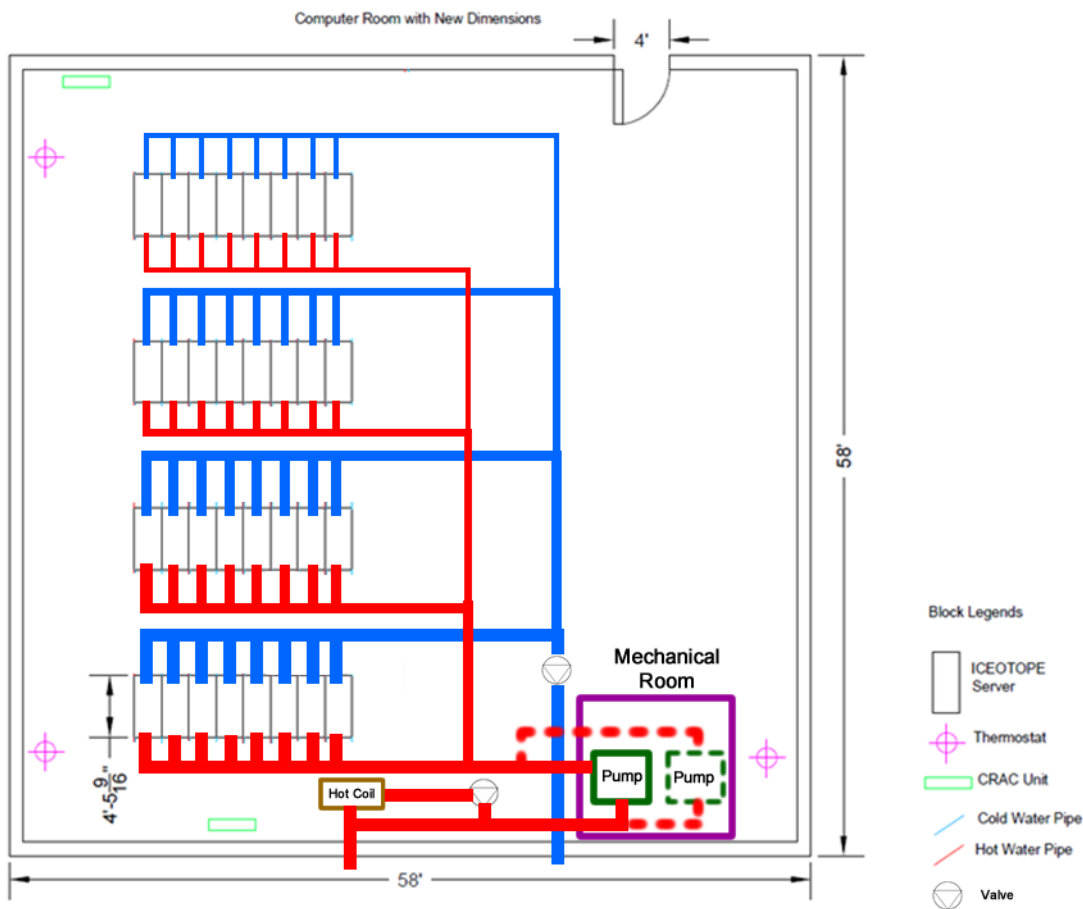

Figure 18: Experimental Computer Room Floor Plan

As a result, the room size can be dramatically reduced. In the above drawing, the new dimensions are 17.7 x 17.7m, the black rectangles indicate the Iceotope Servers, and the red and blue lines indicate

the hot and cold water piped in and out of the room. When comparing the traditional server room with the innovative server room, the amount of total work done remains the same, while the size of the room has been reduced by 60%.

When considering the total power usage, the three main categories were HVAC, IT, and miscellaneous. The miscellaneous category represents all required building functionality that cannot be contributed to HVAC or IT. All of the miscellaneous systems (lighting, outlets, fire alarms) are directly proportional to the size of the building. By making the change to the Iceotope System, the total power spent in each of these areas also drops by 60%. Additionally, the total construction costs of the building drop, as well as the building footprint.

3.5.3: Lighting

The preliminary research into the lighting of the data center suggests that LEDs have the highest lumens to wattage ratio, or the highest efficacy. Our general approach to reducing the carbon footprint, is to reduce the amount of power required to achieve the same amount of work. In this section, T8 fluorescent light bulbs will be compared to some of the leading LED light bulbs (exact LED models were withheld within the research).

There are two primary methods for measuring the output of a light bulb. A lumen is a measure of the “luminous flux” which measures the total amount of visible light emitted from the light source in terms of candela and steradians. Lumens are typically represented in the form of lux. A lux is equal to 1 lumen/m². A footcandle is a similar measurement. One footcandle is defined as a measure of illumination given from one candela at a distance of one foot away. The illumination, or amount of light desired, is an important factor to consider when designed the lighting of any building.

Activity	Illumination (lux, lumen/m ²)
Public areas with dark surroundings	20 - 50
Simple orientation for short visits	50 - 100
Working areas where visual tasks are only occasionally performed	100 - 150
Warehouses, Homes, Theaters, Archives	150
Easy Office Work, Classes	250
Normal Office Work, PC Work, Study Library, Groceries, Show Rooms, Laboratories	500
Supermarkets, Mechanical Workshops, Office Landscapes	750
Normal Drawing Work, Detailed Mechanical Workshops, Operation Theatres	1,000
Detailed Drawing Work, Very Detailed Mechanical Works	1500 - 2000
Performance of visual tasks of low contrast and very small size for prolonged periods of time	2000 - 5000
Performance of very prolonged and exacting visual tasks	5000 - 10000
Performance of very special visual tasks of extremely low contrast and small size	10000 - 20000

Figure 19: Illumination Required by Activity

The illumination required for any room is usually client specified, but in an average data center this can be as low as 200 lux. (Illuminance - Recommended Light Levels)The reasons for this vary, but primarily this server room is not meant to be used as a work space, and most technicians will use a head torch for any maintenance work to be done. Using the area of the room, and the minimum lux, we can determine the total lumens required to light the room.

$$200 \text{ lux} \times 313\text{m}^2 = 62,600 \text{ lumens}$$

Equation 6: Lumens Required for Experimental Computer Room

With the total required lumens for the room, we can examine a variety of lighting options to achieve the required 62,000 lumens.

3.5.3.1: T8 Fluorescent vs. LEDs

In 2010, a study conducted by the U.S. Department of Energy compared T8 compact fluorescent lamps to their LED counterparts. This study compared T8 lamps to LED lamps (exact model information withheld), in their efficacy, quality of light, and life cycle costs. The study installed a mock-up space in the Seattle Lighting Design Lab and measured the price, wattage, and lumens of over fifty different lamps. The highest performing lamps are documented below. (Gordon & Miller, 2011)

Product	Price per Lamp (\$)	Measured Power (W)	Lumen Output (lumens)	Ballast Factor	Efficacy (lumens/W)
Baseline T8 FL	2	28.5	2800	0.88	86.5
High Lumen T8 FL (low BF)	4.55	25.0	3100	0.78	96.7
Obsolete T12	1,85	38.0	2650	0.95	77.5
LED 1	89.69	18.5	1400	N/A	75.7
LED 2	63.75	17.0	1343	N/A	79.0
LED 3	120	22.0	1590	N/A	72.3

Table 3: Efficacy of T8 Fluorescents vs. LEDs

By definition, efficacy is calculated using the following equation.

$$\frac{\text{Lumens Output}}{\text{Wattage Consumed}} = \text{Efficacy}$$

Equation 7: Efficacy of LEDs

However, when using T8 fluorescents, the ballast factor must also be accounted for. The ballast is a part of the T8 lamp responsible for starting or igniting the fluorescent gasses inside T8. This results in a slightly different efficacy equation.

$$\frac{\text{Lumens Output}}{\text{Wattage Consumed}} \times \text{Ballast Factor} = \text{Efficacy}$$

Equation 8: Efficacy of T8 Fluorescents

As seen above, the efficacy of LEDs does not compete with the efficacy of T8 compact fluorescents. However, this contrasts with our background research. This is due to the directionality of the light. LEDs have a high amount of directionality to them, and T8s do not. Lumens are a measure of luminance over a specific area, and if you use a smaller area and a focused LED, the LED will appear to give off more lumens. In the methodology of this study, each light fixture was measured on its ability to light an area the size of a small room. In this respect, it becomes clear that for room lighting, the T8 fluorescent is the right choice. (Gordon & Miller, 2011)

3.5.3.2: Lighting Design

The computer room requires 62,600 lumens, and we will be using the High Lumen T8 FL with low Ballast Factor lamps. These lamps produce 3100 lumens each, and with the following equation the total number of lamps required can be calculated.

$$\frac{\text{Total Lumens Required}}{\text{Lumens Produced per Lamp}} = \text{Total Lamps Required}$$

Equation 9: Total Lamps Required in Experimental Computer Room

The prototype data center will only require 21 fixtures to properly illuminate the computer room. Below is a rough estimate of where each of the lighting fixtures will be placed throughout the room.

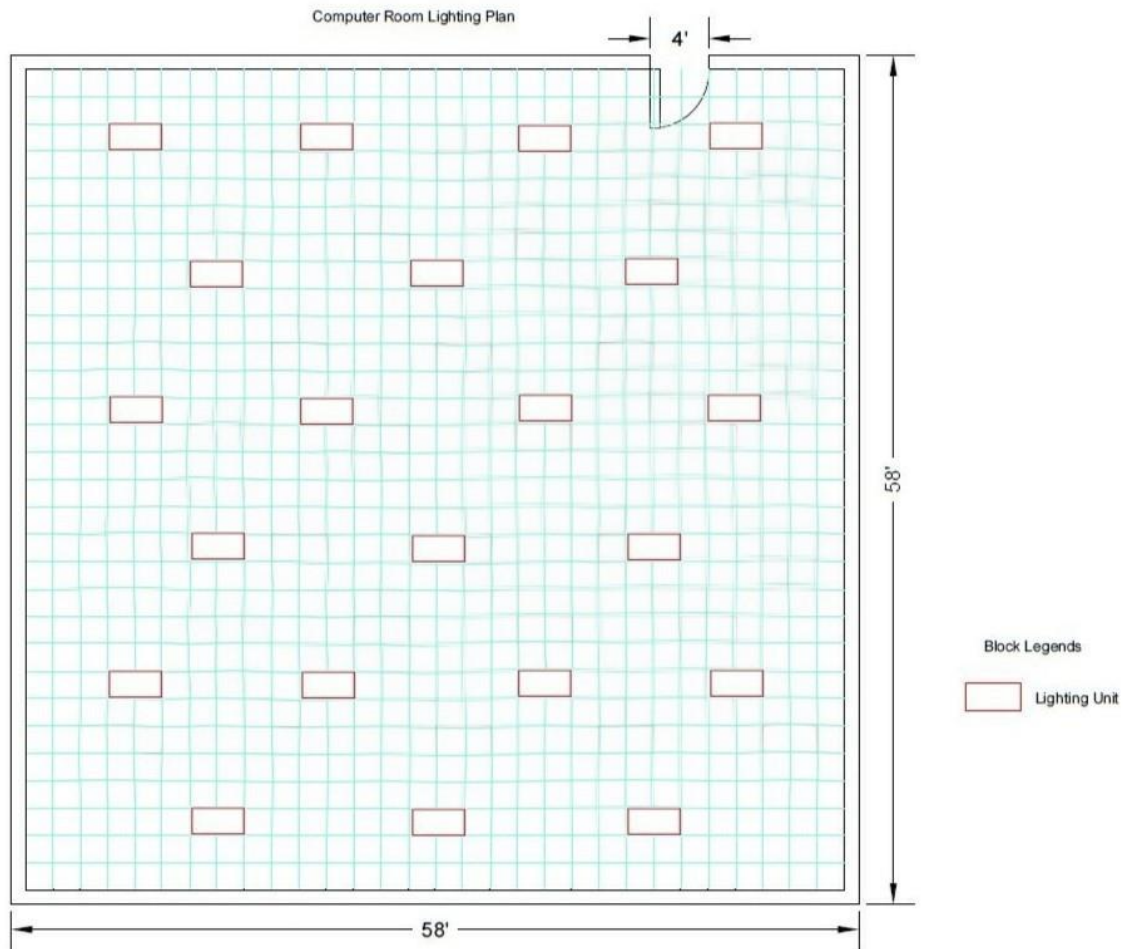

Figure 20: Lighting Plan in Experimental Computer Room

3.6: Reductions in HVAC Power

3.6.1: Air Conditioning

Using liquid submerged servers eliminates the need for industrial strength air conditioning. The Iceotope Solution takes the heat generated by the servers, converts this to hot water, and outputs directly to the Stirling engine. Subsequently, the only air conditioning we need to consider will be for cooling the environment to levels standard for a normal business building, which means maintaining the room temperature from 70 °F to 75 °F.

3.6.2: Example Data Center versus Experimental Data Center

IDG provided the team design drawings of an example data center and a tour for the example data center for additional information. Then, its HVAC system functionality served as a benchmark of the new design.

The example data center has five nearly identical computer rooms. The team analyzed one of those computer rooms as a typical data center. One computer room with its associated electrical room from the example data center was chosen for energy consumption analysis. Each computer room covers an area of 8491.2 square feet (787.65 square meters). Each computer room was built on ASHRAE A1 class (Figure 21). Each computer room was equipped with nine computer room air handlers cooperating with airside economizer system and four humidifiers. Chillers, pumping system and other equipment like fan coil (for battery room) supported the computer room's HVAC system.

Table 2.3 2011 Thermal Guidelines—SI Version

Equipment Environment Specifications for Air Cooling								
Class ^a	Product Operation ^{b,c}					Product Power Off ^{c,d}		
	Dry-Bulb Temperature ^{e,g} , °C	Humidity Range, Noncondensing ^{h,i}	Maximum Dew Point, °C	Maximum Elevation ^{e,j} , m	Maximum Rate of Change ^f , °C/h	Dry-Bulb Temperature, °C	RH, %	Maximum Dew Point, °C
Recommended (Suitable for all 4 classes; explore data center metrics in this paper for conditions outside this range.)								
A1 to A4	18 to 27	5.5°C DP to 60% RH and 15°C DP						
Allowable								
A1	15 to 32	20% to 80% RH	17	3050	5/20	5 to 45	8 to 80	27
A2	10 to 35	20% to 80% RH	21	3050	5/20	5 to 45	8 to 80	27
A3	5 to 40	-12°C DP and 8% RH to 85% RH	24	3050	5/20	5 to 45	8 to 80	27
A4	5 to 45	-12°C DP and 8% RH to 90% RH	24	3050	5/20	5 to 45	8 to 80	27
B	5 to 35	8% to 80% RH	28	3050	N/A	5 to 45	8 to 80	29
C	5 to 40	8% to 80% RH	28	3050	N/A	5 to 45	8 to 80	29

Figure 21: Equipment Environment Specifications for Air Cooling

Since the team utilized the Iceotope Solution, the team came up with a new HVAC system design in the experimental data center. The new HVAC system includes an air-side economizer, a Stirling engine system to recover waste heat, and a pumping system. Later in this report, the team describes the specific details of the experimental data center design. Finally, in the results section, the team created a comparison matrix to compare the example data center to the experimental design.

3.6.3: Iceotope’s Liquid Submerged Cooling System Server Operating Requirements

The Iceotope Solutions conforms to ASHRAE Class W4 water cooling standard (Figure 22). [1] ASHRAE Class W4 requires the facility to supply water temperature between 36 to 113 °F (2 – 45 °C)). Since the W4 cooler standards are within this range of temperatures, there is no chiller required. This means energy savings would be achieved. The situation would be even better if Iceotope could implement W5 standard. For right now W5 is the theoretical class that is desired. Figure illustrate the different classes of the operating requirements for the servers. The team designed the experimental data center using the W4 and W5 as a reference.

Equipment Environment Specifications for Liquid Cooling			
Class	Typical Infrastructure Design		Facility Supply Water Temperature, °C (°F)
	Main Cooling Equipment	Supplemental Cooling Equipment	
W1	Chiller/cooling tower	Water-side economizer	2 to 17 (35.6 to 62.6)
W2			2 to 27 (35.6 to 80.6)
W3	Cooling tower	Chiller	2 to 32 (35.6 to 89.6)
W4	Water-side economizer (with dry-cooler or cooling tower)	N/A	2 to 45 (35.6 to 113)
W5	Building heating system	Cooling tower	>45 (>113)

Figure 22: Equipment Environment Specifications for Liquid Cooling

Class W1, W2, W3

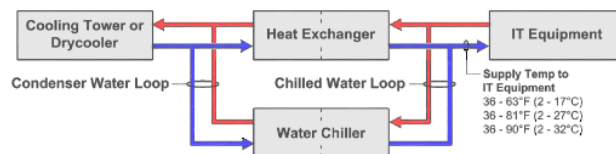

Class W4

No chiller 20-40% energy savings

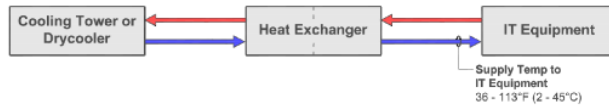

Class W5

Total energy savings would be higher using reclaimed waste heat

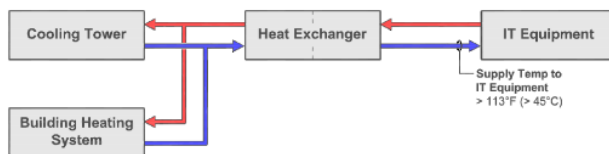

Figure 23: Equipment Requirements on Different Liquid Cooling Classes

3.6.4: Experimental Data Center Temperature Decision

Since the Iceotope liquid submerged servers isolates the servers from the computer room environment, it has no strict requirements for temperature and humidity. As a result, the team decided to design the computer room under normal business building environment temperature. More specifically, the experimental data center temperature would be maintained from 70 °F to 75 °F. To implement this temperature decision, the team did a heat gain and loss analysis of the experimental computer room and came up with an HVAC system design that uses a Stirling Engine to recover waste heat and dry cooler units to reject excess waste heat. Figure 24 and Figure 25 below illustrate the heat

flows into and out of the experimental computer room in summer day time (peak cooling - Figure 24) and winter night time (peak heating - Figure 25) modes.

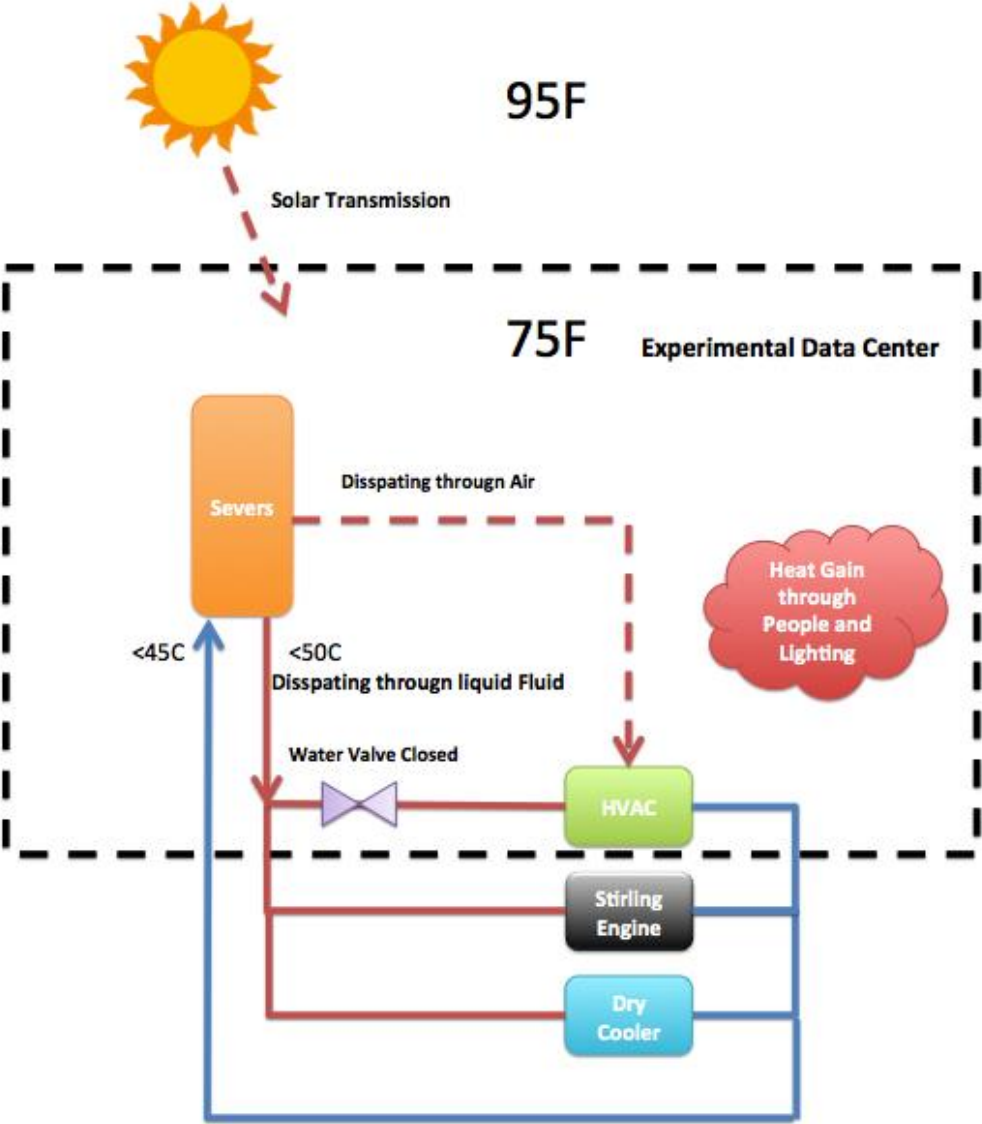

Figure 24: Peaking Cooling



OF

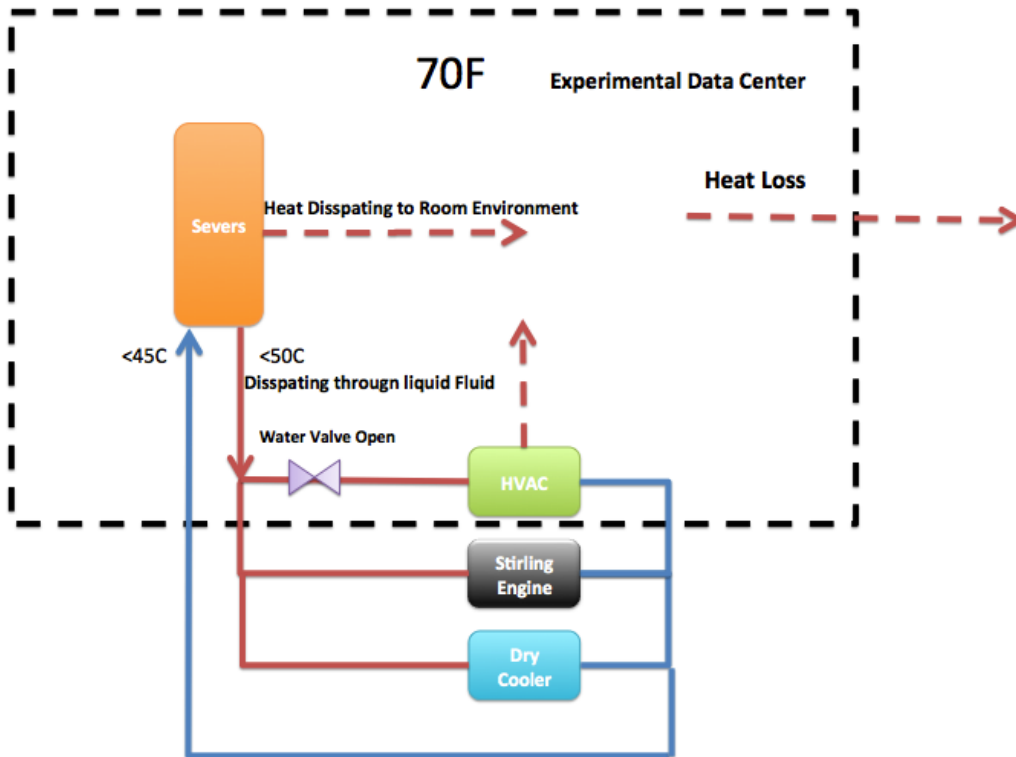

Figure 25: Peak Heating

3.6.5: Heat Gain and Loss Analysis of Experimental Data Center

To achieve heat balance of the experimental computer room, first we needed to identify the heat input. The team assumed three people working in the experimental data center with all lights on and the room under the condition of summer day time with outside temperature at 95°F. As a result, the heat input to the room would be solar transmission through the structure (roof, walls and floor), Iceotope liquid submerged servers heat dissipation, and miscellaneous (people and lighting) as figure 24.

An article entitled *Iceotope plans to revolutionise the traditional data centere states*, “The server system claims to be up to 90 percent efficient at capturing heat from the submerged servers, which can then be transferred and recused to heat other devices, such as domestic radiators, at temperature up to 50 degree Celsius thus doubling power saving.” (Bell, 2013) The team calculated the heat dissipation of Iceotope liquid submerged servers using this statement. As the result, the heat

dissipation from Iceotope liquid submerged servers then rejected to the experimental data center would be 253,700 BTU/hr. (Appendix A1).

Applying the equations from the book *Air Conditioning Principles and Systems*, the team calculated the heat gain through the structure (roof, walls and floor) and heat gain through people and lighting (Appendix A1). The total including heat dissipation from Iceotope liquid submerged servers, heat gain through the structure (roof, walls and floor), heat gain through people and heat gain through lighting is 281,200 BTU/h (see table 5).

Table 4: Heat Gain Calculation Results

Heat Gain Through	Heat Input(BTU/hr)
Iceotope Liquid Submerged Servers Heat Dissipation	253,700
Structure (Roof)	10,600
Structure (Walls)	14,400
Structure (Floor)	0
People	700
Lighting	1,800
Total	281,200

After identifying the heat input during summer day time, there was still another situation that needed to be considered, which is the heat loss during winter time. The team assumed that the experimental data center operating during winter night time with outside temperature 0°F. And the room temperature of the experimental data center would be design as 70 °F indoors. Then the team calculated the heat loss through the structure (roof and walls) and mechanical ventilation (Appendix A2). The total heat loss through the structure is 89,200 BTU/hr (table 5). Although the Iceotope liquid submerged servers would still operate, as calculated they would dissipate 253,700 BTU/hr to the experimental data center which is greater than the heat loss through the structure. However the team

concerned that Iceotope liquid submerged servers might not running at their 100% load. So the team determined there could still be heat loss from the experimental data center.

Table 5: Heat Loss Calculation Results

Heat Loss through	Heat Loss(BTU/hr)
Structure (Roof)	18,600
Structure (Walls)	25,300
Mechanical Ventilation	45,400
Total	89,200

3.6.6: HVAC System with Air-side Economizer Design of Experimental Data Center

To reach a room temperature range of 70 °F to 75 °F in the innovative data center, the team designed an HVAC system consisting of a rooftop unit with air-side economizer and a duct mounted hot water heating coil.

The airside economizer utilizes “free cooling “of outside air. In the example data center, the air-side economizer cooperated with 9 computer room air handler (CRAH) units in each computer room. Due to the Iceotope’s liquid submersion cooling system implementation, the team designed a new HVAC system.

The team created a schematic diagram for the new design of HVAC system (Figure 26). The mission of HVAC system is to maintain the room temperature from 70°F to 75 °F. The air-side economizer has temperature sensors and programming to control the outside and return air dampers. Basically the principle of air-side economizer is to mix return air from the computer room with outside air, then supply the cool mixture to the computer room. The temperature sensor and air damper with programming control operates the system to maintain a certain room temperature, in this case would be from 70°F to 75°F. Since the outside air temperature varies daily, the economizer works in conjunction with the roof top unit compressors to condition room temperature during summer time. Aduct-mounted hot coil connected to the circulating fluid that cools the Iceotope submerged cooling system provides heat to the experimental data center during winter time. A water valve in the

circulating fluid loop opens when the room temperature of experimental data center falls below 70 °F. Hot water from Iceotope liquid submerged servers would flow through the hot coils to heat the experimental data center.

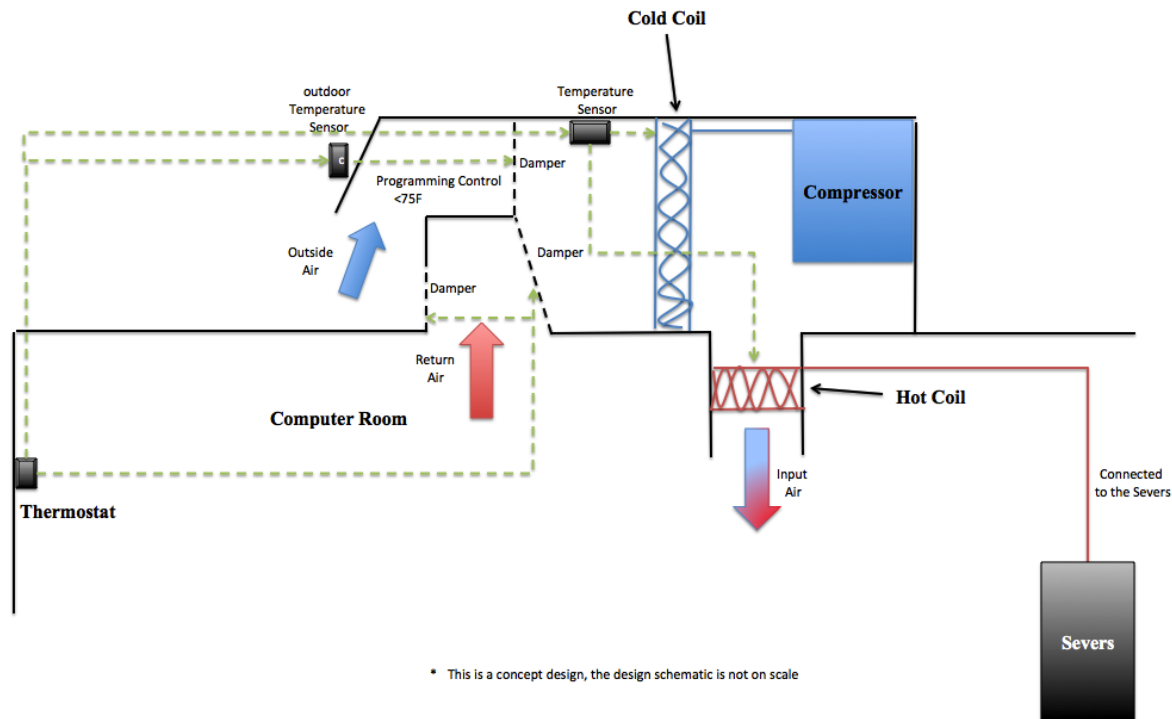

Figure 26: HVAC System with Air-side Economizer

3.6.7: Rooftop Unit and Hot Coil Implementation

After designing the HVAC system, the team selected roof top units and duct-built-in hot coils. The team also applied “N+1” (N stands for the number of unit needed) redundancy to achieve reliability of the HVAC system functionality.

Based on the heat gain calculation results, the team calculated the capacity and the air flow for the roof top unit (Appendix A3). The selection of the roof top unit based on the unit could air condition the experimental data center to 75 °F during summer time day with outside temperature of 95 °F. Then the team chose Carrier WeatherMaster 48P (30-100 Ton) for the rooftop unit. To justify the specific capacity of the rooftop unit, the team utilized spreadsheet tool from an article named simplifying the selection of roof top unit to test different capacities of the Carrier WeatherMaster rooftop unit (Elovitz, 2010). From the spreadsheet tool results (Appendix A3), 40 tons WeatherMaster rooftop unit (48/50P2, P3, P4, P5040) would lead to space sensible load (-1.4%) shortage. Although 50 tons WeatherMaster rooftop unit (48/50P2, P3, P4, P5050) would have no shortage on both space sensible load (20.4%

excess capacity) or space latent load (263.9% excess capacity), the team still chose the 40 tons WeatherMaster rooftop unit (48/50P2, P3, P4, P5040). The consideration for this decision were the test criteria for the rooftop unit based on maximum load, hottest day during the year and only a very small percent (-1.4%) of shortage. That tiny shortfall did not justify increasing capacity to 50 tons per unit, especially where the design incorporates a redundant unit that could run if needed to cool the space.

. The team chose Coil Company as a manufacturer for hot water coils and utilized their coil selection program (http://www.coilcompany.com/coil_selection.html). Using the coil selection program, the team selected a hot water coil which could input enough heat during winter night time with outside temperature 0°F (performance data in Appendix A4). According to the design, hot coils would be built into the ducts of the roof top units.

3.6.8: The Stirling Engine and Dry Cooler Cooling System

A data center utilizes a significant amount of energy, and most of the energy turns into heat. Right now combined heat and power (CHP) systems are either considered or implemented, depending on several factors, such as the scale of the data center, the applicability of the system based on external factors (e.g. climate), and the cost efficiency of such implementation. Still the CHP system does not capture 100% of the waste heat. As a remedy to this situation, three systems were investigated: Stirling engine, thermoelectric device and absorption refrigeration. Stirling engine and thermoelectric device do cogeneration because they generate work/electricity and absorb heat at the same time. On the other hand, absorption refrigeration is another utilization of waste heat, even though it does not fall under the cogeneration criterion. More details can be found out in the Technology section and Appendix A5 of our report. After consideration of the three possibilities, the Stirling engine is the most applicable one to the project because thermoelectric device work on smallest temperature range and that is not suitable to our project, while absorption refrigeration has the most complicated design. Plus, just building an absorption refrigeration system to generate cold does not make economic sense. In order to make the Stirling engine application feasible, we need to connect the servers to the engine. The wattage required by the servers would be the heat that we need to dissipate.

The team created a schematic diagram of the Stirling engine implementation. As shown below (Figure 27), water flows through the servers at ≤ 45 °C, and leaves at ≤ 50 °C. The water is driven by a pump that is kept in a mechanical room. The hot water coil is attached but there is no flow in the summer because we don't need to heat up the room. In winter, we are going to divert 5% of the flow to

that, leaving 95% of the flow to the other equipment (pieces). On the hot water coil, there is a valve that controls the flow. If flow is needed, the valve will open, and vice versa.

The flow then goes to the Stirling engine. It has a hot side and a cold side. The hot side has a heat exchanger that takes ≤ 50 °C (122 °F) water from the loop, transfers heat to the working fluid of the engine (typically air), and return ≤ 45 °C (113 °F) water. Because the working fluid absorbs heat from the hot side heat exchanger, it expands, and gives out motion for the engine, and the motion can be utilized for generating electricity. After compression, the working fluid turns from low temperature/low pressure to high temperature/high pressure. The cold side also has a heat exchanger to cool the high temperature/high pressure working fluid down, and then the working fluid can take more heat from the loop. Heat is rejected to the ambient environment.

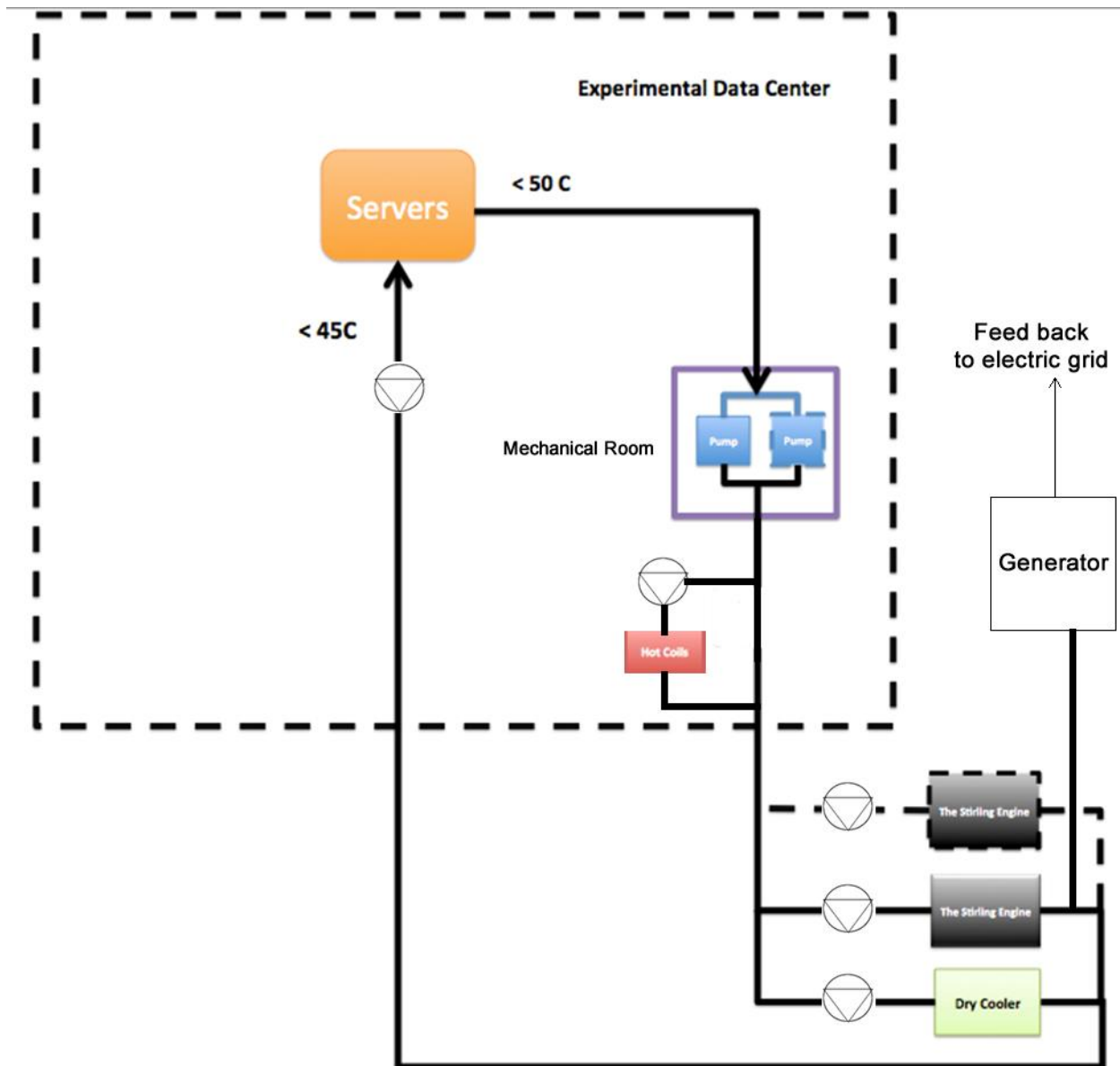

Figure 27: Experimental Data Center Water Flow

Ideally, the flow is flowing 100% to the Stirling engine. The reason why we are connecting both the Stirling engine and the dry cooler is because of redundancy concerns. If the Stirling engine fails, the flow is going to divert to the dry cooler. We can also split the flow by the valves attached to the equipment in case the Stirling engine is not functioning properly, in ratios like 20%/80%, 25%/75% to get to the output water temperature of $\leq 45^{\circ}\text{C}$. After the utilization of waste heat, the water temperature is $\leq 45^{\circ}\text{C}$, and the cycle starts again.

The team researched on Stirling engine manufacturers and discovered that a company called Infinia manufactures 30 kW Stirling engines. The concept of having a 30 kW Stirling engine system is to

interconnect six 5 kW engines together. The engines are free-piston, that means they don't have a crankshaft to control the piston motion; rather they are driven by the combustion chamber gases, a rebound device (e.g. a piston in a closed cylinder) and a load device (e.g. a gas compressor or a linear alternator). Their estimated weight for the prototype is 900 kg, and their preliminary production weight is estimated to be about 540 kg.

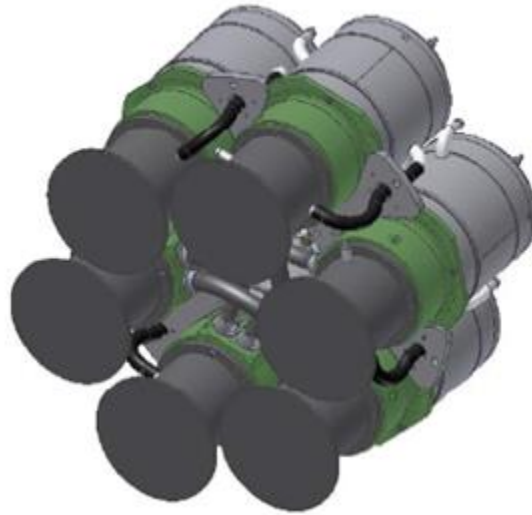

Figure 28: Infinia 30 kW Stirling Engine System Design

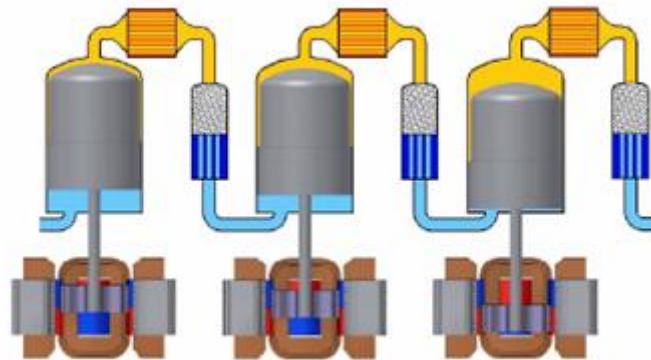

Figure 29: Infinia 30 kW Stirling Engine System Design

Based on the Stirling engine efficiency calculation, we just need one 30 kW system all year round.

0 °C (winter) => $(1 - \frac{273}{323}) * 600000 \text{ W} * 0.30$ (efficiency of engine)* = 27863.8 W = 27.864 kW so we need one system

33 °C (summer) => $(1 - \frac{306}{323}) * 600000 \text{ W} * 0.30 = 9473.68 \text{ W} = 9.474 \text{ kW}$ so we need one system

The minimum mechanical output of a system is 9.474 kW, and the maximum is 27.864 kW.

If the efficiency of the system is greater, the system can produce even greater output. Also, the output can be greater if bigger Stirling engines are manufactured; in fact, theoretically Stirling engines can be made as big and powerful as desired. Another way to increase the output is to connect multiple systems in parallel; that idea was rejected since connecting them in parallel would be complicated on the electrical side.

The above numbers are only for mechanical output; that is of little importance to the project if that cannot be transformed into electrical output. As a result, a generator is connected to convert mechanical power to electrical power. Detailed calculations can be seen in Appendix A7.

In the situation when the Stirling engine fails, the flow needs to be diverted to the dry cooler for heat dissipation. In order to do that, the team went to a website of a manufacturer called York by Johnson Controls to look up the proper dry cooler for the project.

TABLE 5G - FLUID COOLER SELECTION TABLE - 1.0 HP FAN, 840 RPM ¹

Model	Fans Wide	Fans Long	Coil Circuits	Fluid Flow (gpm) ²											
				350		400		450		500		550		600 ²	
				Load (MBH)	PD (ft)	Load (MBH)	PD (ft)	Load (MBH)	PD (ft)	Load (MBH)	PD (ft)	Load (MBH)	PD (ft)	Load (MBH)	PD (ft)
VDCF224B10XXB	2	2	54	22.54	26.31	22.78	33.73								
VDCF226B10XXB	2	2	82	23.10	10.54	23.26	13.46	23.40	16.70	23.48	20.27	23.56	24.16	23.64	28.35
VDCF226B10XXC	2	2	56	23.34	32.49	23.48	41.57	23.58	51.68						
VDCF228B10XXB	2	2	108	22.26	7.19	22.36	9.19	22.42	11.43	22.48	13.88	22.52	16.56	22.54	19.46
VDCF234B10XXB	2	3	54	33.18	33.91	33.60	43.37								
VDCF236B10XXB	2	3	82	34.20	14.11	34.52	17.98	34.76	22.28	34.96	26.99	35.10	32.11	35.24	37.64
VDCF236B10XXC	2	3	56	34.58	42.75	34.86	54.58	35.06	67.73						
VDCF238B10XXB	2	3	108	33.12	9.41	33.32	12.01	33.46	14.89	33.56	18.06	33.66	21.50	33.72	25.22
VDCF244B10XXB	2	4	54	43.34	41.51	44.02	53.01								
VDCF246B10XXB	2	4	82	44.94	17.68	45.48	22.50	45.88	27.84	46.20	33.70	46.46	40.06	46.66	46.92
VDCF246B10XXC	2	4	56	45.48	52.99	45.94	67.57	46.30	83.75						
VDCF248B10XXB	2	4	108	43.78	11.64	44.12	14.82	44.36	18.35	44.54	22.22	44.68	26.43	44.80	30.97
VDCF254B10XXB	2	5	54	53.00	49.11	54.04	62.64								
VDCF256B10XXB	2	5	82	55.28	21.25	56.10	27.01	56.74	33.40	57.22	40.40	57.60	47.99	57.92	56.18
VDCF256B10XXC	2	5	56	55.96	63.22	56.72	80.54	57.28	99.75						
VDCF258B10XXB	2	5	108	54.14	13.86	54.70	17.63	55.08	21.81	55.38	26.38	55.60	31.36	55.78	36.72
VDCF264B10XXB	2	6	54	62.18	56.70	63.62	72.26								
VDCF266B10XXB	2	6	82	65.14	24.81	66.36	31.52	67.26	38.95	67.96	47.09	68.52	55.92	68.96	65.44
VDCF266B10XXC	2	6	56	66.00	73.42	67.10	93.48	67.94	115.73						
VDCF268B10XXB	2	6	108	64.18	16.07	65.02	20.43	65.62	25.25	66.04	30.54	66.38	36.27	66.64	42.45

1. Base Capacity, MBH per °F TD for 40% Ethylene Glycol at 130°F Mean Fluid Temperature; Base Pressure Drop includes headers.
 2. Don't exceed maximum fluid flow for unit as shown in Table 8.

Figure 30: Dry Cooler From York by Johnson Controls Specifications

The flow rate of our experimental design is 455.2 GPM, and the head/pressure drop is 55.27 ft (detailed calculations in Appendix A9), so a dry cooler that has 67.73 ft pressure drop will have the closest result. The model number for the product is VDCF236B10XXC, so people can search the model number for more information.

For the selected model, there are 6 fans (two times three), and each has 1.0 hp, so 6 hp is required for the fan. Converting that into kW, 6 hp -> 4.41 kW.

The dry cooler can reject the full amount of heat the servers put into the loop when the Stirling engine malfunctions.

3.6.9: Pumping and Piping System

The details of the layout of the piping system and the selection of the pump are listed in Appendix A9. In our project, there are four rows of server racks; each of them requires a specific pipe size and diameter for a pipe section to let water flow by. As hot water flows to the Stirling engine/dry cooler, it dissipates the heat from the servers, and pressure drops as water flows. All the pressure drops are summed up and a pump is selected. For redundancy purposes, another identical pump is also connected to the piping system in case the first pump fails.

3.7: Reductions of Carbon Footprint

3.7.1: Carbon Footprint Comparison of Some of the Building Materials

As the main purpose of our MQP project is to reduce the carbon footprint of data centers, it is important to consider different building materials to reach the design conclusion. For this goal, the Environmental Analysis Tool application by Skidmore, Owings & Merrill was used to compare several building materials' carbon footprint data. The application requires inputs such as the area, structural building material, amount of stories, construction duration estimation, and etc. By plugging in the information derived from the architectural drawings sent by the IDG for the example data center an approximated building material carbon emission amount was drawn out from the application.

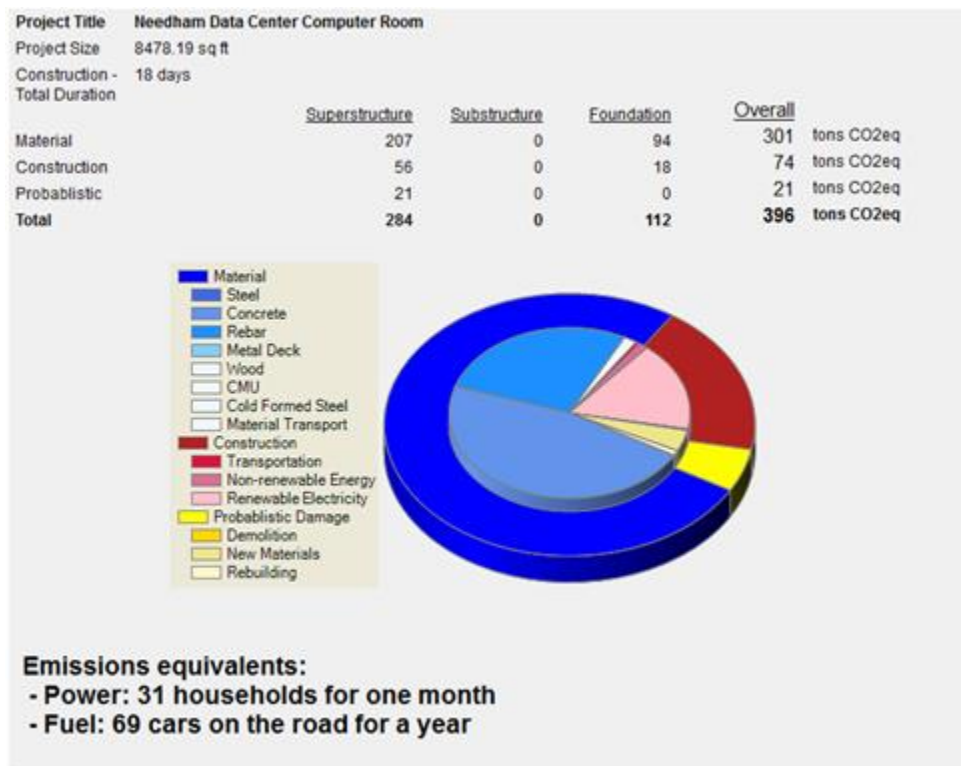

Figure 31: Example Data Center Computer Room EAT Carbon Emissions Chart

Figure above shows that approximately 396 tons of CO₂ equivalent was released into the planet due to the building material production, handling and construction for the example Data Center computer room on its second floor. Since our group aims to use this room as a control element, the comparisons are based solely on the computer room.

In order to meet Architecture 2030, it is necessary to at the very least reduce the carbon emission amount shown in the data chart above. One effective way of doing so is to simply reduce the

floor area of the room, which is made possible by using the liquid cooled servers instead of traditional ones. The new server systems don't require room next to them for air circulation as much as the traditional servers do; they also do not impose as much density load, which further facilitates the reduction in the size of the room. Figure below shows the second case where the room dimensions are changed, while all other input elements are held the same.

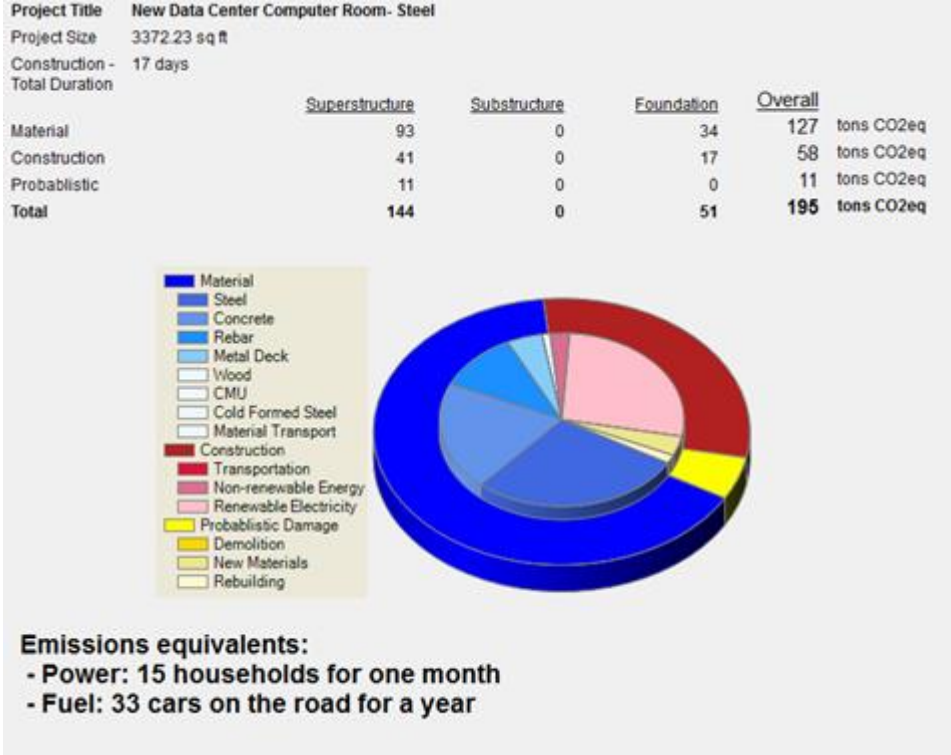

Figure 32: New EAT Carbon Emissions Chart

As can be seen from the data chart, this change results in 201 tons CO₂ equivalent elimination, creating a 50.7% positive decrease. In order to gain further efficiency, other structural building material types were considered and plotted in the application. Table below shows the results of this comparison.

Structural Material	CO ₂ Footprint (tons of CO ₂ equivalent)
<i>Steel (Example Data center room)</i>	<u>396</u>
Steel	195 (50.8%)
Composite	169 (56.3%)
<u>Cold Formed Steel</u>	<u>126 (68.2%)</u>
Concrete Masonry Units	173 (56.3%)
Wood	168 (57.6%)
Concrete	170 (57.1%)
Concrete Using Liquid Granite instead of Portland Cement*	85-136* (21.6-34.3%)

Table 6: CO₂ Footprint Comparison

The results show that using concrete made with using liquid granite instead of Portland cement as the main structural building material is the most effective way to further reduce carbon footprint. However, the studies done on this material so far are not very detailed. The second most efficient material, cold formed steel, is a proven structural material that has been used for a long time. Therefore in future designs, the engineers may consider switching from steel to cold-formed steel for achieving Architecture 2030. However for the purposes of this MQP, a structural design and analysis is made with using steel for the WPI CEE Department Capstone requirement.

3.7.1.1: Structural Design Considerations in Data Centers

The function of a data center infrastructure is mainly to support the IT equipment. Column spacing may affect the number of racks that can fit within the building. The increasing density of IT equipment requires more power and more cooling per rack, and therefore the unit weight also increases with the advancements in technology.

Room height is also another aspect to take into consideration in the structural design of a data center. Since air cooling is dependent on delivering the cooling air (for air-cooler systems) to the load. The height of the room can have a significant effect in this situation. *ASHRAE Guideline: Structural and Vibration Guidelines for Datacom Equipment Centers* will be explained in detail and will be used as a guideline.

3.7.1.2: Raised Access Floor (RAF) vs. Overhead Cable Tray

Traditional servers often require air-conditioning zoning management since otherwise the operational cost with the rising electricity pricing rates would be more substantial. In the example data center design, one of the white spaces we were able to observe during our field trip consisted of a combination of RAF and overhead cabling. However, with the use of liquid cooled servers, underfloor air control is no longer a necessity. Therefore, in our new design, just by removing the need for airflow management, material savings that leads to carbon footprint elimination can be achieved. In this case our design will consist only of overhead cable trays to assist the ductwork and cable management. The biggest concern posed by recollections of the example data center field trip is the lack of aesthetic integrity for clients. Nonetheless, taking a step towards Architecture 2030 can sometimes relatively mean sacrificing other values such as the aesthetics of the space. This reason leads us to be persistent with using overhead cable trays.

3.7.1.3: Structural Design Process

The structural design portion of the final MQP deliverable includes maximizing passive cooling aspects by using the right materials that facilitate meeting the Architecture 2030 goals.

In B term the team designed sketches of the new design by hand and in AutoCAD, later in this period a structural analysis started being made by hand calculations and then using the STAAD Pro software. The 2009 International Building Code with additional amendments legislated by the Commonwealth of Massachusetts were used for the structural design,. ASCE 7 were used to account for the corresponding loading scenarios. Further design restrictions and recommendations in building data centers are stated in Structural and Vibration Guidelines for Datacom Equipment Centers by ASHRAE, which are also followed.

The final structural building material is steel members. Phase Changing Material (PCM) infused drywall (Micronal) is also incorporated into the design to further achieve Architecture 2030 goals. Precast concrete panels made from geopolymers are another part of the design for a reduced overall initial carbon footprint. The main reason for this selection lies with the principles of Architecture 2030, which is to decrease carbon footprint of the buildings to zero. As explained in the background, the structural steel industry is constantly improving at reducing the GHG emissions during production. Another benefit to using steel is its high renewability. American Institute of Steel Construction (AISC) states that 88% of all steel products and nearly 100% of structural steel beams and plates used in construction are recycled into new products. Concrete slab is also chosen not only for its high strength in

compression, but mainly for its high thermal mass. This quality of the material will result in a higher passive cooling rate of the building, which will alleviate the burden of the HVAC system. In order to increase the effect of this principle, PCMs will be included in the experimental building being used on the drywalls, maximizing the passive cooling aspects.

3.7.1.3.1: Methodology:

The first step in the structural design process was to determine the loads acting on the building. Design live loads for snow and live loads were chosen based on building codes. The snow, wind and earthquake loads for the example data center location were determined by ASCE 7. The design live load was also chosen for a computer room space with high density equipment. The Stirling engine load was accounted for by factoring in an additional roof live load for the roof beams and girders.

The layout of the building was created in AutoCAD. A representative data center section was intended to be used for the purposes of our project, and therefore it was decided that the MQP group was going to design a computer room and an electrical room instead of working on the complete data center building. The example data center features a computer room and an electrical room as the following:

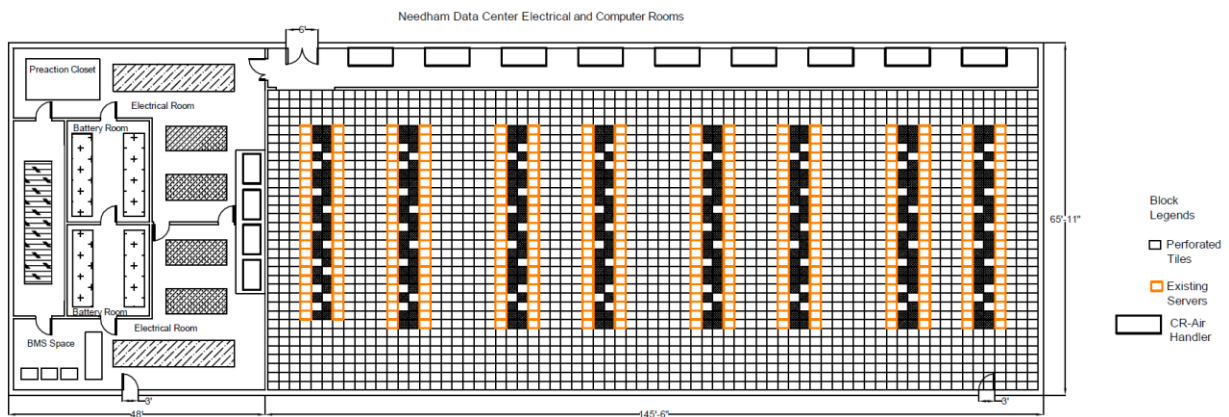

Figure 33: Example Data Center

(A more detailed version can be found in the Appendix)

As can be observed in the layout, there seems to be a lot of open space especially in the computer room. This can be explained by the hot and cool aisle requirements for conventional server systems. However, in the experimental data center that our team is proposing, we incorporated liquid cooled servers that do not require air circulation for their cooling needs. Therefore, if we were to

directly transfer the computing power of the example data center to the experimental one, there would still be empty space which is not needed in this case. As a result, our team has decided to eliminate a portion of the computer room space in order to make building material savings that will both be economically and environmentally beneficial. The new data center dimensions can be seen in the following figure.

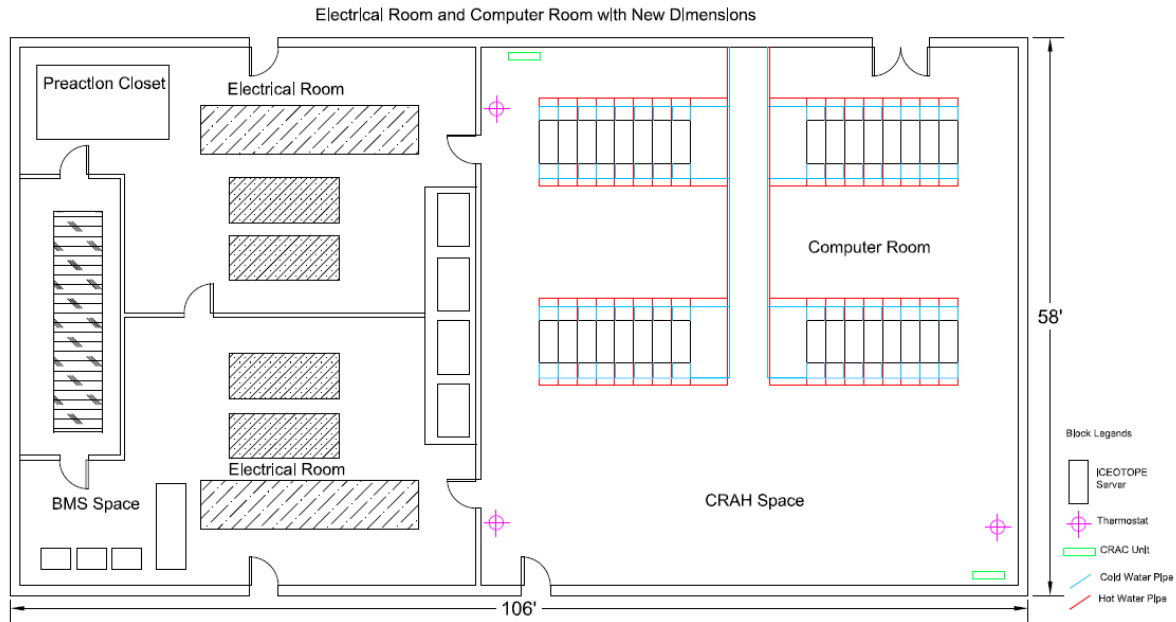

Figure 34: Experimental Data Center

(A more detailed version can be found in the Appendix)

The experimental data center was desired to be a one-story building with a column spacing of 14.5 ft in the transverse direction and a spacing of 26.5 ft longitudinally. This column spacing can seem to be fairly large, however it is necessary to accommodate the need for open areas in a data center white space.

Geographical location information is crucial for structural design purposes since the building codes apply accordingly. The location of the example data center was chosen for our experimental design in order to achieve a better comparison for Architecture 2030 purposes.

Two different moment frames were designed that had to be subjected to external conditions such as snow, earthquake, and wind. Structural analysis software was then used to compute the shear and axial forces along with the bending moment values for these frames and other structural members. The deadweight from the concrete slab on the roof, other building materials (such as insulation) and determined structural member weights were then added to check for the beam size. Deflection for the beams and girders was limited to 1/360 of their span.

3.7.1.3.1.1: Architectural Layout:

The one-story experimental data center was designed to be 20 feet in height. The large value of the height is due to overhead ducting and cabling needs since the new design eliminated the use of an RAF system. The concept combination of rooms is 106 feet long and 58 feet wide. Two frames were created to stabilize the structure. One frame is 26 feet wide and the other is 14.5 feet wide. Both frames are 20 feet in height and support four filler beams. The concrete slab on the floor and the roof are both 5 inches in thickness. The structural framing plan can be found in the Appendix.

3.7.1.3.1.2: Load Case Determination

In order to select the most cost-effective members that will provide safety for the structure, the first step was to determine the loads. The first loads to be determined are dead loads which comprise the self-weight of the members and permanent fixtures in the building. For this purpose, AISC Steel Manual was used to determine the load of the selected member after an iterative design process, and 150 pcf was used as a typical weight for concrete slab.

The second step was to determine the live loads. For this purpose, ASCE 7 guideline was used. The snow load for the example data center location was found to be 40 psf and the data center white space live load was factored in as 100 psf to be conservative for the high density of the equipment. This conservative live load will accommodate building design for the equipment used in the entire building.

The third step was to find the designated lateral loads which are for earthquake and wind. After obtaining both loads, the higher one will govern and will be selected as the main lateral load acting on the structure since both extreme conditions cannot be considered at the same time. The wind speed for the example data center location was found to be 100 mph from the IBC Massachusetts Commentary. Factors for gust, exposure, and pressure were then added to calculate the final wind load. Even though an earthquake/seismic load analysis for a one-story building located in a very low-risk location may seem unnecessary, it was determined nevertheless for learning goals. The wind load turned out to be higher and governed for the lateral loading scenario.

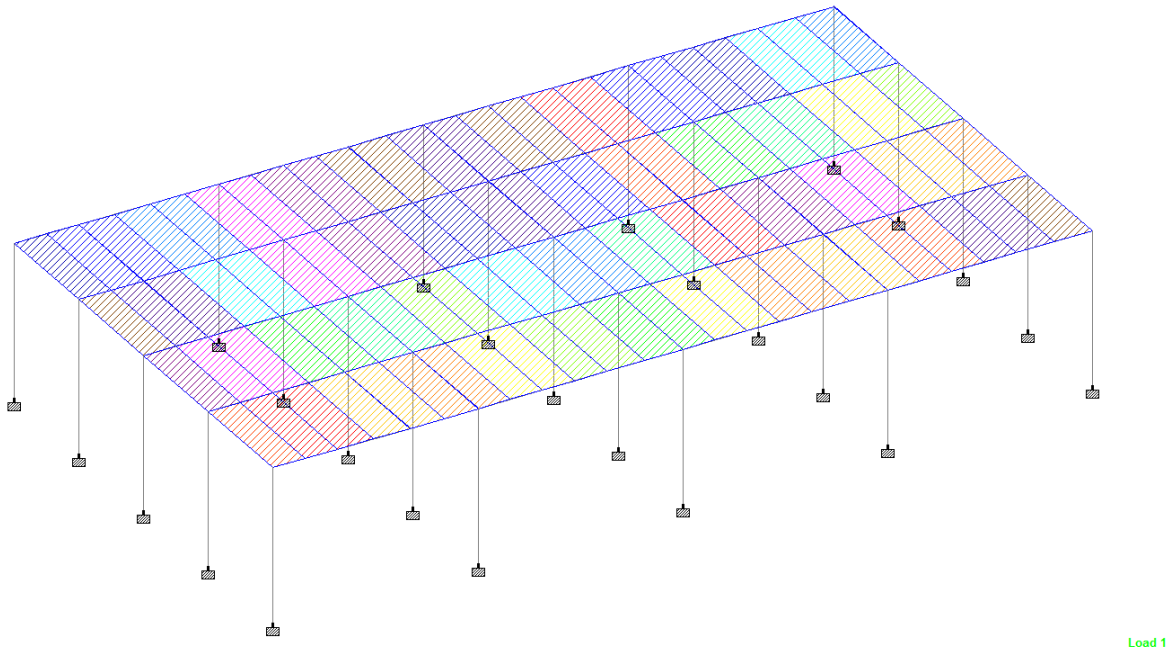

Figure 35: Live Load Case

3.7.1.3.1.3: Structural Member Design

The first members to be designed were the beams which were subjected to both dead and live loads. The first part of dead load which was the concrete slab was computed by multiplying the thickness of the concrete by the weight of it and the tributary area acting on the beam. An assumed beam self-weight was added at the beginning to account for the possible result. The snow live load and the conservative live load factor for the Stirling engine was then added to determine the moment acting on the beams. Then the allowable section modulus Z was determined and the AISC Table 3-2 was used to select the lightest W -Shape to be cost-effective. A similar route was followed in order to determine the most efficient girder size. The only difference was the tributary area and the resulting self-weight. After the beam and girder sizes were obtained, the column design needed to be carried out. STAAD Pro was used to determine the maximum forces and moments that would be acting on the columns. The combined axial force and bending moment effects were then compared to the AISC Manual Chapter 4 in order to make the best column size selection.

Chapter 4: Results

The following results were obtained using the methodology which was elaborated on in the section above.

4.1: Energy Saving Matrix

The goal of our project is to reduce the carbon footprint to be as low as possible, and we can achieve this objective by reducing the energy consumption of them. Attached is the energy saving matrix created in order to compare the energy consumption in the experimental data center and the example data center.

Systems	Example Data Center	Experimental Data Center
Maximum Power Consumption		
UPS	1223 kW (92% efficient)	652 kW (92% efficient)
Servers	1125 kW	600 kW
Chillers	656.8 kW (Theoretically)	-
Inside Computer Room	208.8 kW	(Computer Room AC)
Computer Room Air Handler	(Inside Computer Room)	None since no chiller in W4 Class
Circulation System	78.3 kW	(Pumps)
Pumps	52.2 kW (Theoretically)	7.612 kW (See Appendix A5)
Humidifier	6.4 kW	-
Fan Coil	2.24 kW	Included with UPS
Computer Room AC	None in scope of project	7.034 kW
Lighting	1.749 kW	0.693 kW
Miscellaneous	0.130 kW	0.052 kW
Dry Cooler	-	(If Stirling engine fails, 4.41 kW)
Roof Top Unit	-	59.68 kW
Power Generation		
Stirling Engine	-	Worst case: 8.053 kW

		Best Case: 23.684 kW (assuming 30% efficient engine and 85% efficient generator)
Total	3354.62 kW	1327 kW – 8.053kW (worst case) 1327 kW – 23.684kW (best case)

Table 7: Energy Saving Matrix

Of course, it is inappropriate to compare the whole existing building to our one-room approach because some equipment is outside of the computer room, e.g. the electric unit heater, so we totally omit them on our matrix. We are only doing a one-room comparison between the example data center and the experimental design, and we are only considering the equipment on both.

For calculation purposes, we assume all of them to run at 100% load and 100% redundancy. We know that assumption is impractical because climate and load percentage change at different times, but the purpose of calculating 100% load and 100% redundancy is to show the total wattage (or total capacity) of the computer room before and after the new approach. If we conclude that the new design is 50% more energy efficient when assuming 100% load and redundancy, adjusting the calculations to the actual load and redundancy may yield an even higher saving.

4.2: Electrical Line Diagram

A line diagram is used to show the logic of an electrical circuit without being so detailed that an average reader wouldn't understand. In the following figure, the line diagram for the experimental data center can be reviewed.

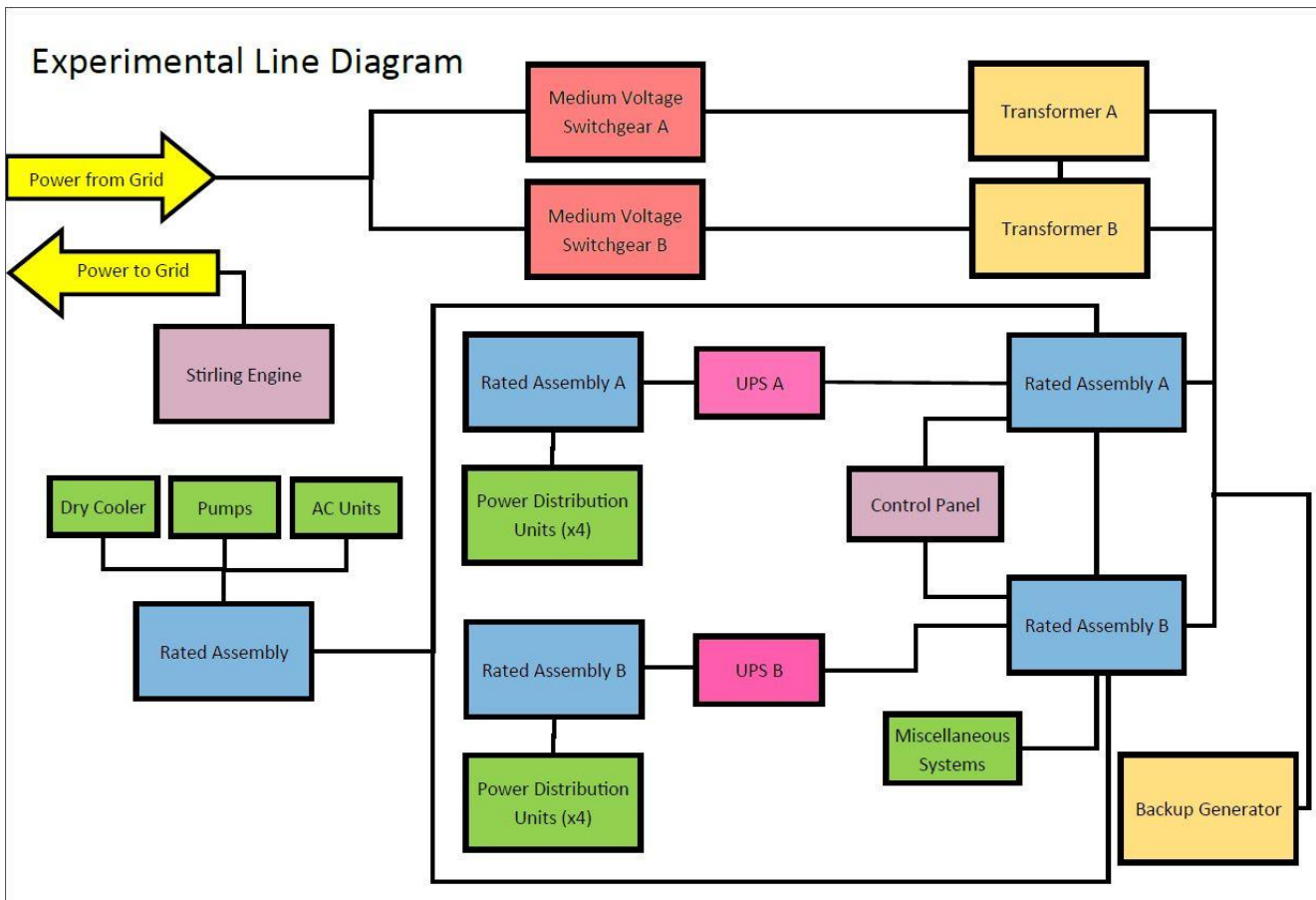

Figure 36: Experimental Line Diagram

The various stages of the line diagram are organized by color. Starting in the top left corner and going clockwise, yellow blocks indicate where the power is being either drawn from or returned to the grid. The red blocks indicate the Medium Voltage Switchgear. Switchgear uses fuses, disconnect switches, and circuit breakers to isolate the building from large power fluctuations that may occur in the power grid. The experimental data center uses two switchgear (labeled here as A and B) to serve as a backup in the case that one should fail. In all data centers, redundancy and reliability are important, so most systems will be in duplicate.

In the orange blocks, there are two transformers and a backup generator. Prior to this stage of the line diagram, all power is considered “medium voltage”. Medium voltage is loosely defined by Siemens as anything above 1kVac to 38kVac. Transmitting power at high voltages reduces the current required, and thus reduces the amount of power lost over long distances. However, appliances are not all rated for large voltages, and before practical use, the voltages must be stepped down. Transformers

can accomplish this, and they further protect and isolate the buildings from power fluctuations. At this point in the system, the backup generator is introduced. If there was a total grid failure, the backup generator block indicates where in the line diagram the power from the generator room would take over.

The blue blocks represent rated assemblies within the building. Essentially, they are electrical distribution centers. All subsequent building systems that require power, will be connected to a fire-rated assembly. Note that in this stage of the line diagram, the system is split in two parts, with a control panel to facilitate user control during an emergency where a PDU or a UPS might fail. In pink, the UPS serve as a further isolation and protection from the main power supplies. UPSs are used to provide uninterrupted power to the servers during the brief moments of transition where an emergency may occur and the backup generators are being turned on. While not pictured above, each UPS is served by a battery bank, to facilitate that smooth transition. These UPS blocks then feed right back into an electrical assembly, which organizes and provides power to the PDUs.

The green blocks indicate the systems that are directly using the power. The miscellaneous systems represents all lighting, outlets, etc. These systems are of minor importance, so they do not need to be handled in duplicate like the rest of the data center systems. The PDUs are the physical units sitting in the computer rooms, and each computer is plugged directly to the PDUs. The next stage of the line diagram shows a final assembly that is feeding the three HVAC systems that require power. These green blocks indicate the air conditioning units required to cool the building to average room temperatures, the pumps required to move all of the building water, and the dry cooler which acts as a backup for if the Stirling Engine fails. This final assembly is connected to both Assembly A and B, for redundancy.

Lastly, the last purple block on the page, is not connected to rest of the line diagram, because the Stirling Engine does not require any power to be run. Instead, using the hot water generated by the servers, it is generating electricity. It is important to be notated on the line diagram, because the Stirling Engine will not be feeding the building (and subsequently the building) itself. Including this infrastructure is not feasible, especially while it is common practice for power companies to shoulder the burden. (Elovitz, 2014)

4.3: Building Material & Structural Design Results

Table below shows the final structural steel W-Shape member requirements. Figure 10 and 11 show the STAAD Pro renderings of the W-shapes and the analysis results.

Member Type (Structural Steel)	Member Size (2-Shape)	Length (Feet)
Roof Beam 1	W 12x19	14.5
Roof Beam 2	W 12x26	14.5
Roof Girder 1	W 21x68	14.5
Roof Girder 2	W 21x93	26.5
Columns	W 14x74	20

Table 8: Structural Members Selected

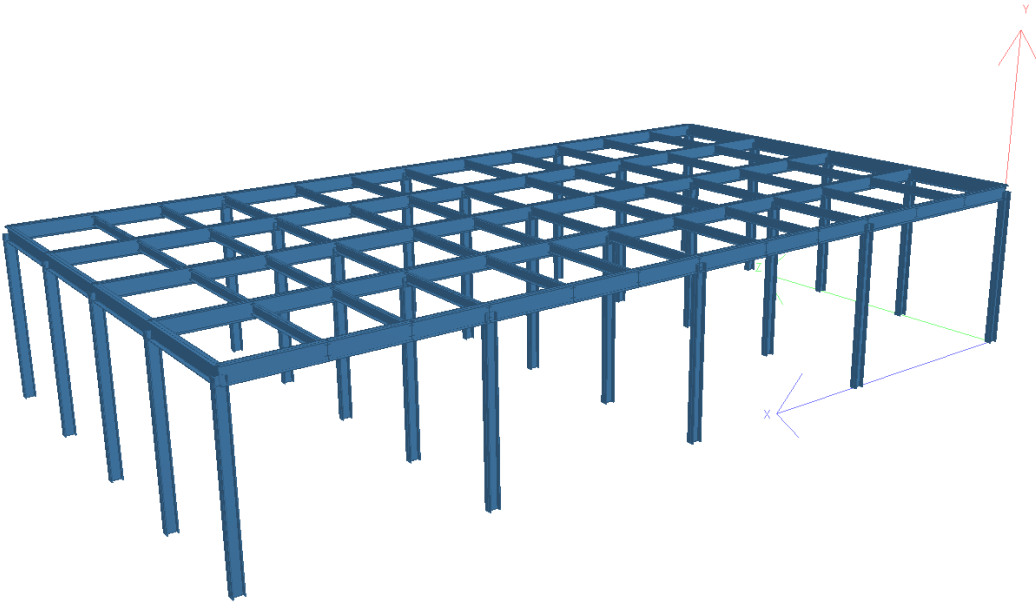

Figure 37: Experimental Data Center Structural Framing

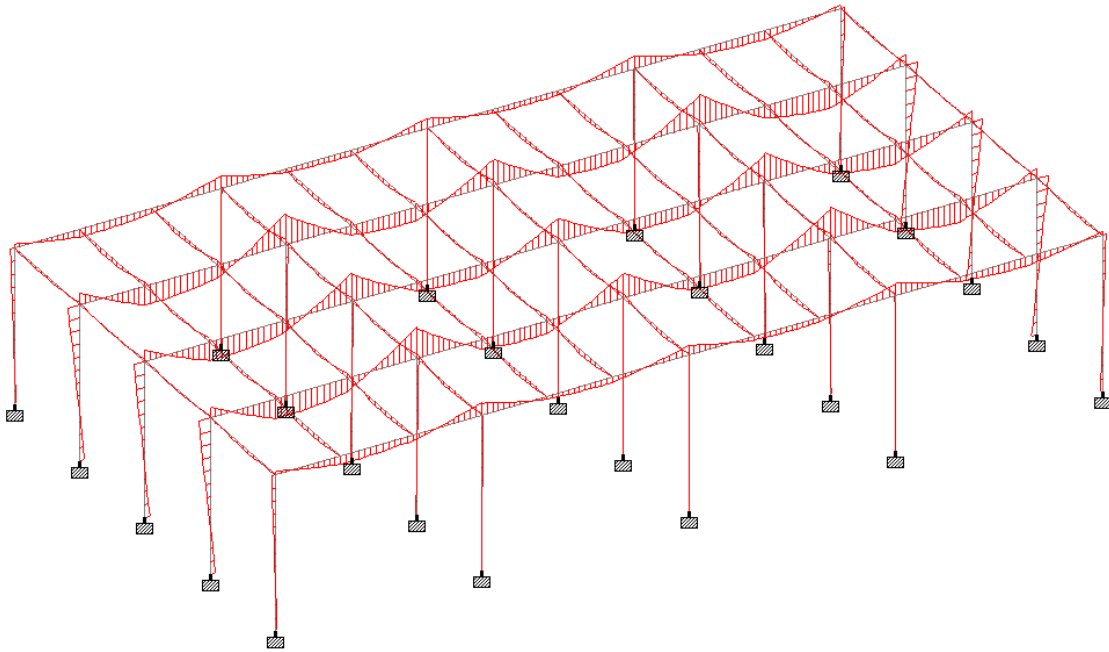

Figure 38: Experimental Data Center Structural Analysis

After performing an analysis in STAAD Pro, the members were found to be adequate for the design. A double-angle connection was designed for the column with the highest stress rate and the girder connecting. 3 A325-N bolts spaced 3 inches apart, used with a 3-½ in by 3-½ in by ½ in double-angle connection satisfies the connection capacity V_u . The calculation process can be found in the Appendix.

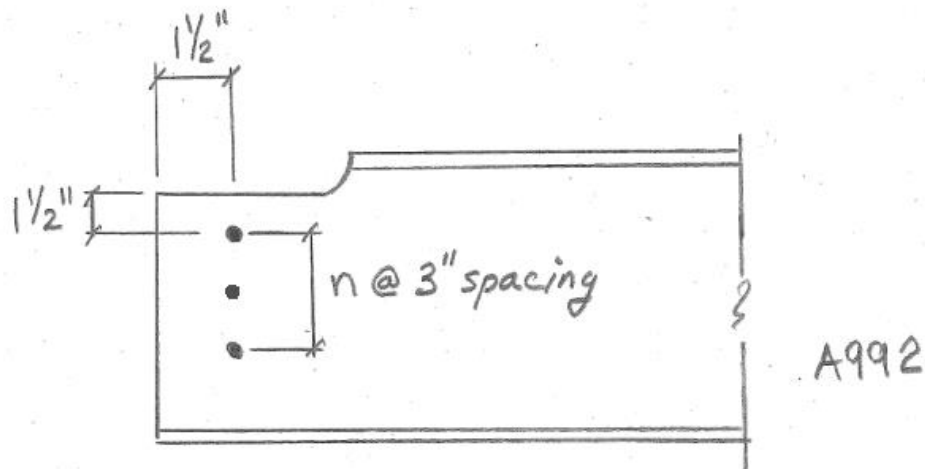

Figure 39: Girder-Column Connection Design

An appropriate footing size for the columns was found using the calculation process in the Appendix. The Table and the Figure below present the foundation results. The pedestal is not a necessity for the purposes of this design, it was determined only for educational purposes.

Foundation Element	Size
Base Plate (A36 Steel)	13 x 13 x 2 in
Concrete Pedestal	18 x 20 in
Footing	24 x 24 x 16 in

Table 9: Foundation Elements

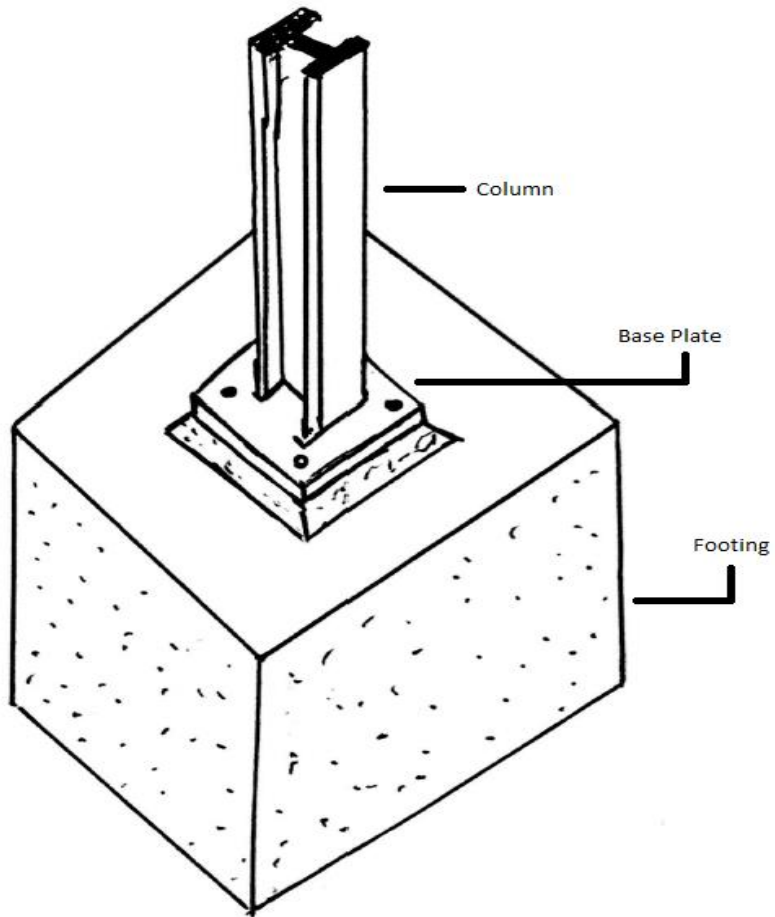

Figure 40: Foundation Design

Figures below show the final building materials selected for the design of the experimental data center walls and the roof:

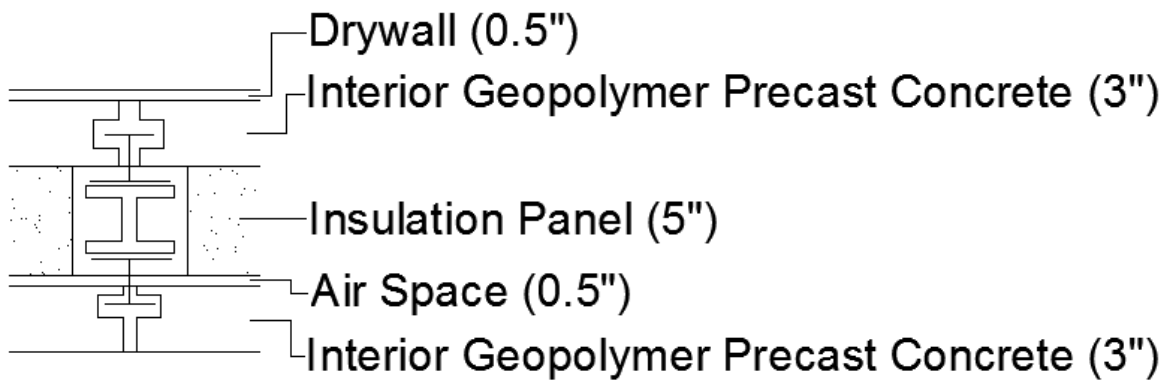

Figure 41: Wall Plan

The exterior wall includes precast geopolymer concrete, insulation, vapor barrier, air retarder, and PCM infused drywall Micronal. The roof consists of geopolymer concrete slab on metal decking, PCM infused insulation, and waterproof membrane.

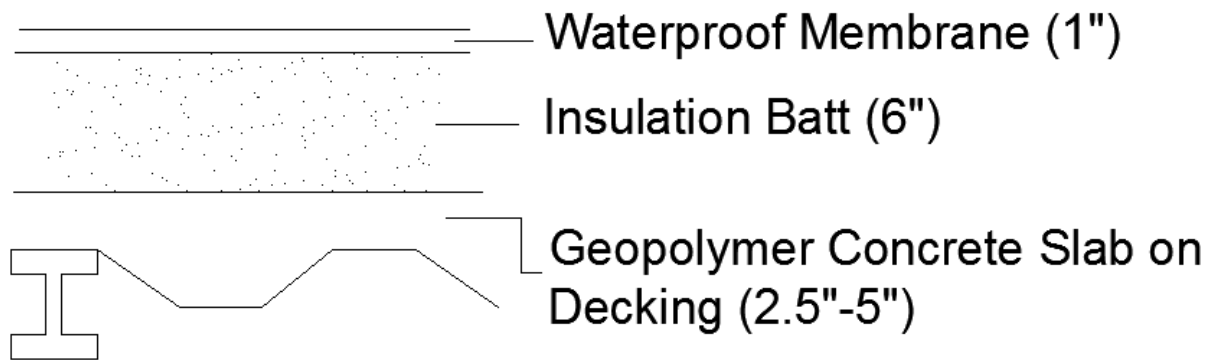

Figure 42: Roof Section

4.4: Revit Modeling:

A 3D model of the new design with the reduced room dimensions is made in Revit, as shown in the figures below.

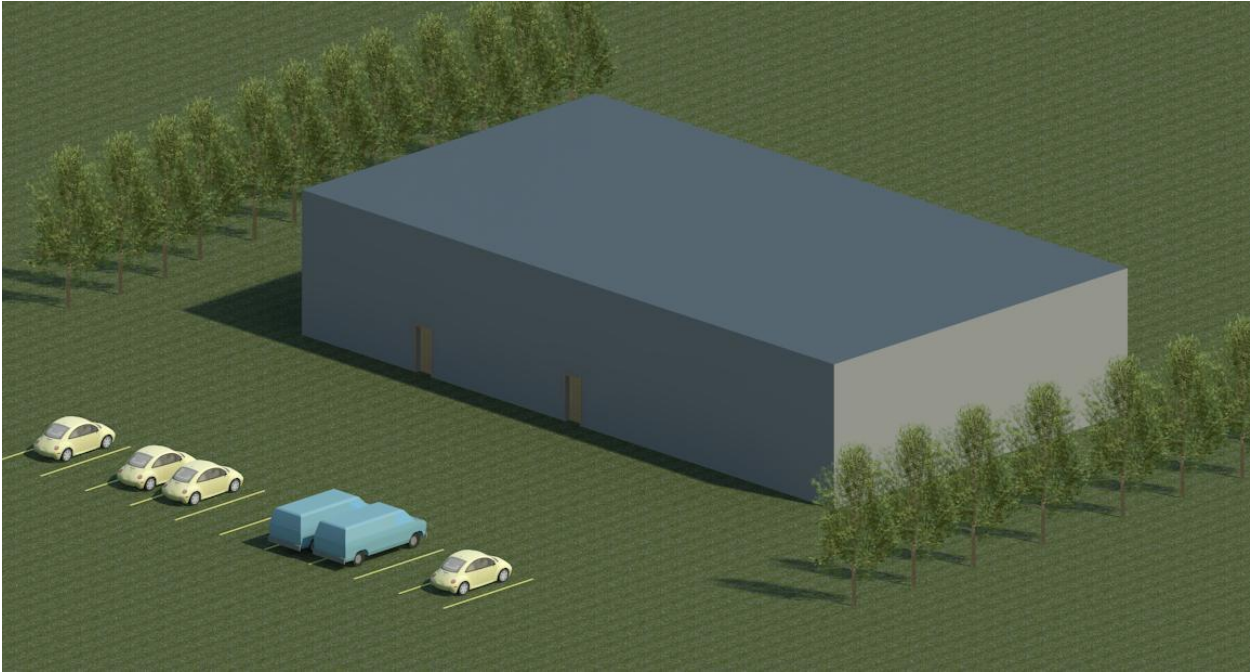

Figure 43: Experimental Data Center

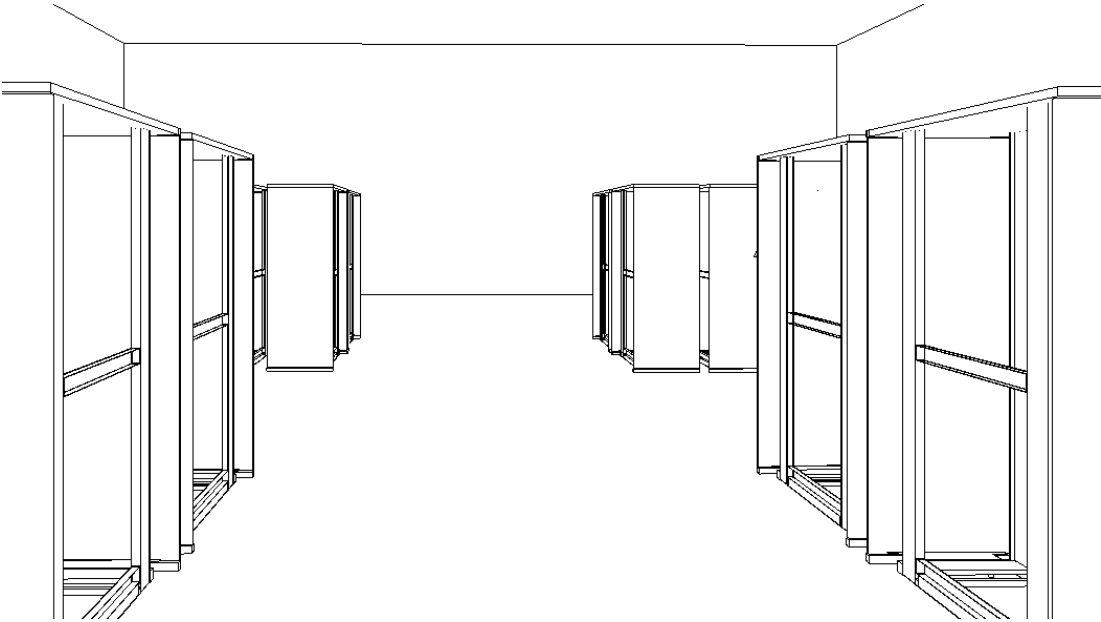

Figure 44: Experimental Data Center CR

Chapter 5: Discussion

The few changes recommended (such as switching to liquid-submerged servers and consequentially reducing the required computer room size, selecting more environmentally friendly building materials, and using a Stirling engine) will have an immense impact in the first steps towards meeting Architecture 2030 requirements. This MQP also displayed the necessary design elements expected from WPI students with the structural design, line diagram, and HVAC design.

The most significant change accomplished by this data center, was making the switch to Iceotope servers. This technology is very young, and has not been widely implemented yet. This project had to use critical thinking and problem solving in order to determine a method to best implement these servers. The most significant design changes were a result of making this one fundamental switch. From here, we needed to build an HVAC system that revolved around cooling water, rather than air. The second biggest impact to the system, is the Stirling Engine. Using the hot water from the Iceotope Solution, the experimental data center recovers energy, instead of using energy to cool it. Making the switch to liquid immersed servers also meant that the computer power to physical space ratio was dramatically reduced. Water has a far higher specific heat capacity, and therefore it is far more successful at cooling tightly packed computers than air. Packing the computers tightly together dramatically impacted the physical footprint of the building. These savings translated into every aspect of the project. The smaller your building, the smaller your carbon footprint. We also looked into other systems to reduce the carbon footprint. Looking into other fundamental systems, the project investigated how efficous the traditional industrial lighting is. While LEDs are rumoured to have the biggest energy savings, this is largely due to the fact that they are generating less light.

The comparison between the example data center and the experimental data center in terms of building materials clearly shows that having a substantial amount of carbon footprint reduction is feasible. Phase Changing Material incorporated drywalls reduce the HVAC loads by passively controlling the room temperature, therefore they indirectly create carbon footprint saving benefits. The geopolymer concrete panels provide up to 90% less carbon dioxide during their production compared to regular concrete, due to the elimination of using Portland cement. Reducing the size of the computer room, which was made possible by using liquid-submerged servers, adds to the material savings, and consequentially CO2 footprint reductions.

The structural design process included following building codes, selecting the structural materials, and determining the sizes of the members, the footing, and the connections. This component of the project satisfies the Capstone Design Requirement by the WPI Civil Engineering Department.

The Mechanical Engineering approach to reduce the carbon footprint of data centers includes implementation of an air-side economizer to utilize “free cooling” of outside air, switching to liquid-submerged servers to eliminate the use of the chiller, rooftop unit and hot Coil implementation, and the utilization of the Stirling engine to recoup and reuse the waste heat.

Compared to the example data center, new components include hot coils and rooftop units are added into the HVAC system on the experimental data center. The air-side economizer design which utilizes the “free cooling” is maintained from the example data center. Other new pieces of equipment include the Stirling engine system and the dry cooler.

From the comparison matrix, the experimental data center could save more than half amount of energy the example data center consumed due to the selection of a smaller pump based on smaller coolant flow, the elimination of a humidifier because the new servers are less susceptible to the environment as well as the elimination of chiller since the new servers conform to ASHRAE W4 liquid cooling standard. However, the comparison matrix is based on the maximum load of the equipment of both example and experimental data center. Switching from ASHRAE A1 class to ASHRAE W4 class may achieve energy saving, but there is no way for verification in our project since our comparison is based on maximum load, which is not realistic. The reasoning behind the comparison matrix is to show the maximum possible values of both design, not the actual values. Another concern on the verification is that the approach of the project is the “one-room concept”, which is not an accurate representation of the actual situation. Simply divide the total load of the building by the number of rooms and compare to a single new room is not scientific since it is not a control volume model. Also, The example data center applied different levels of redundancy. For example, the example data center applied “N+3” redundancy for computer room air handler (CRAH), while the experimental data center applied “N+1” redundancy for rooftop unit and pump. Although different levels of redundancy were applied in the example data center, the experimental data center applied proper level of redundancy to achieve the reliability of data center operation.

The delivered results of this project, are several architectural and structural drawings, an electrical line diagram, and an energy savings matrix. This energy savings matrix does not indicate what average use savings might be. It is unrealistic to be able to determine an average use energy savings with such a diverse system, especially since some of these technologies are extremely new and have

limited documentation. This energy savings matrix only indicates differences in what the maximum drawn power will be for each system. With this information we can design the experimental data center, but the exact power consumption cannot be determined. However, it is still clear, that under maximum conditions, the experimental data center can complete all the same computing work, while requiring only 38% of the power of the traditional data center.

Without knowing exact power consumption during daily use, the exact carbon footprint of the building cannot be determined. However, ultimately the goal of this project was to make an attempt at meeting the Architecture 2030 design challenge. While this project was unable meet the challenge, it is important to remember that the challenge was to the entire building sector. Data centers are commercial buildings that use a significant amount of the world power supply, and generate a significant amount of heat. The fact that we were able to make such large gains at all, is significant.

Overall this project was beneficial for the students' learning since every member of the group needed to acquire a good understanding of the different components of the MQP even when the subject was not related to their major. The multi-disciplinary aspect of this MQP can easily be translated into the real world where company engineers will need to work through various backgrounds to design a solution for any given task.

Chapter 6: References

- American Society of Heating, Refrigerating and Air-Conditioning Engineers. (2012). *Thermal guidelines for data processing environments*. (3rd ed.).
- Architecture 2030. *Atom*. Architecture 2030, n.d. Web. 20 Sept. 2013. <<http://architecture2030.org/>>
- Article 646 Modular Data Centers N.p.: n.p., n.d. N. pag. Rpt. in National Electrical Code. 2014 ed. Quincy: NFPA, 2013. Web.
- Bergman, T., Lavine, A., Incropera, F., & Dewitt, D. (2011). *Introduction to heat transfer*. (6th ed.).
- Biello, D. (2008). Cement and Carbon Dioxide. Retrieved February 15, 2014, from <http://www.scientificamerican.com/article/cement-from-carbon-dioxide/>
- Brandon, J. (2011). Attention, data center managers: Copy these innovations.
- Walker, G., & Senft, J. R. (1985). *Free piston stirling engine*.
- Oegema, Bernard. *IBM Data centre operational efficiency best practices: Best practices to plan and design a data centre for the 21st century*
- Davidovits, J. (1993), Carbon-Dioxide Greenhouse-Warming: What Future for Portland Cement, Emerging Technologies Symposium on Cements and Concretes in the Global Environment
- Dixit, S.; Ekbote, A.; Judge, J.; Pouchet, J. (Nov. 2008). *Reducing data center energy consumption*.
- Green Data Center. Personal photograph by unknown author. N.d.
- Gonchar, J.; Syrkett, A.; Malone, A. *Greensourcemap Case Studies*. (2013, May & June)
- Iceotope Servers Offer Full Time, Free Cooling For Cloud Services. Iceotope Offer Full Time Free Cooling For ICT Anywhere. Iceotope, n.d. Web. 03 Oct. 2013. <<http://www.iceotope.com/>>.
- Integrated Design Group. *Facebook Open Compute Project*. (2013)
- International Building Exhibition IBA Hamburg (2012). Smart Material Houses. Retrieved November 9, 2013, from <http://www.iba-hamburg.de/en/projects/the-building-exhibition-within-the-building-exhibition/smart-material-houses/biq/projekt/biq.html>
- International Energy Agency (2012). World Energy Outlook. Retrieved February 9, 2013, from <http://www.worldenergyoutlook.org/publications/weo-2012/#d.en.26099>
- Kongtragool, B., & Wongwiset, S. (2002, 10). *A review of solar-powered stirling engines and*. Retrieved from <http://www.inference.phy.cam.ac.uk/sustainable/refs/solar/Stirling.pdf>
- Mahasanan, Natesan; Steve Smith, Kenneth Humphreys, Y. Kaya (2003). "The Cement Industry and Global Climate Change: Current and Potential Future Cement Industry CO2 Emissions". Greenhouse Gas

Control Technologies – 6th International Conference. Oxford: Pergamon. pp. 995–1000.
doi:10.1016/B978-008044276-1/50157-4. ISBN 978-0-08-044276-1.

Mangat, P. (2012). Liquid Granite. Retrieved February 28, 2014, from
<http://www.ideaconnection.com/invention-success/Liquid-Granite-00046.html>

Measuring Success. *Greensourcemag*. (2013, May & June)

Schiavon, Stefano; Lee, Kwang Ho; Bauman, Fred; & Webster, Tom. (2010). Influence of raised floor on zone design cooling load in commercial buildings.. UC Berkeley: Center for the Built Environment. Retrieved from: <http://escholarship.org/uc/item/7bf4g0k1>

University of East Anglia. (2009, November 17). Fossil fuel carbon dioxide emissions up by 29 percent since 2000. ScienceDaily. Retrieved February 24, 2014 from
www.sciencedaily.com/releases/2009/11/091117133504.htm

Valkeakoski, Nasrollah Naddaf, HAMK University of Applied Sciences. Stirling engine cycle efficiency

WorldSteel Association (2012). Steel's Contribution to a Low-Carbon Future. Retrieved February 15, 2014, from <https://www.worldsteel.org/publications/position-papers/Steel-s-contribution-to-a-low-carbon-future.html>

Chapter 7: Appendix

Renewable Energy Resources

Current sustainable energy production systems include, but are not limited to: solar, wind, biofuel, geothermal, carbon neutral/negative fuels and hydrogen energy. Not only are these energy resources renewable, but also they do not entail any environmental hazards such as boosting carbon footprint. Therefore replacing the conventional methods of energy producing with these alternative solutions is inevitable in order for all the current establishments and systems that are in use to still function in the absence of fossil fuels. There are currently many ways to make use of sustainable resources by implementing energy conversion systems.

Solar Power

One of the most wide-spread sustainable energy resources is solar power. The main reason could be that every hour the sun beams onto Earth more than enough energy to satisfy all the energy needs for an entire year. However the main reason that this potential is not currently being harvested lies with the efficiency levels of the systems used in the conversion process. Some systems convert the heat gained from this energy, while others can include photovoltaic cells for electricity conversion.

Biowalls

Covering the entire surface of the wall buildings with a living organism is currently in practice mainly for its good air-filtering qualities and aesthetical benefits. However, current studies suggest that these walls could also be used to harvest energy if sealed containers of algae photo-bioreactors could be integrated into the sides of buildings to produce biofuels and sequester carbon. As the algae grow they absorb CO₂ from the surrounding air which can then be stored.

One of the benefits to harnessing agriculture for biofuels is that it can use waste-water and ocean water, and it is relatively harmless to the local environment should it spill or leak. Algae also has a much higher production rate per acre (or vertical foot in this case) than soy or corn. Additionally, some studies have shown that up to 99% of the CO₂ introduced to the solution can be converted or sequestered. Since reducing the emission of GHG is the number one priority of Arch 2030, integrating this system to a data center may yield great results.

Case Study: *Algae Tank Building Façade, The BIQ House*

The first building that has applied the theoretical algae biowall energy production technique was designed and set for build in late 2011 in Hamburg, Germany. Named as *the BIQ House*, this residential

building is covered by an outer shell of microalgae on the sun-facing sides. Algae must be supplied with nutrients and carbon dioxide, and with sunlight they can grow. As soon as the algae are ready to be harvested, they get transferred as a thick pulp to the technical room of the BIQ. It is here that the little plants are fermented in an external biogas plant to be able to regenerate biogas. This method has been enabling the building to supply its own energy since it was completed in March 2013 (International Building Exhibition IBA Hamburg, 2012).

Case Studies

In order to look more deeply into the actual application of carbon emission/energy use elimination/reduction, several cases from Greensourcemag were studied to provide a more complete scope of the goal. There are four cases that achieve either elimination/reduction: Bullitt Center in Seattle, WA; Conrad N. Hilton Foundation Headquarters in Agoura Hills, CA; Bioinnovation Center in New Orleans, LA; and Galileo's Pavilion, Johnson County Community College in Overland Park, KS.

The Bullitt Center in Seattle, WA is an example of a building that achieves emission/energy use elimination. It achieves LBC (Living Building Challenge Certification), and it consumes no more water than rain collected on its walls and no more electricity than that from the solar panels. (Gonchar, J., 2013) One thing that has to do with the Seattle rainy weather is the number of panels required being quite large. A design aspect of the building is its use of attractive stairs to encourage stair usage than elevator use, and thus it saves energy. The building also employs climate control system and depends on natural ventilation and automated, operable windows to maintain a comfortable temperature. However, the climate control system is not the only thing that has to do with temperature. The space heating and cooling is done by radiant floor system that taps the consistent earth temperature via geothermal wells.

Another example of zero carbon/energy dependency is the Conrad N. Hilton Foundation Headquarters in Agoura Hills, CA. The complex employs solar thermal-heating system/solar thermal array, water-cooled chilling and a planted roof for lowering the interior temperature. It also employs photovoltaic panels for solar energy. But the crown jewel is the passive-downdraft HVAC system which provides ventilation and cooling. It comprises 17 downdraft shafts or "chimneys" that punctuate the perimeter and are visible outside, peeking out over the roof plane at regular intervals. (Syrkett, A., 2013) Air travels down these shafts, entering the floors of the 2nd and G levels. Cold water pumped into coils below each chimney's air-intake baffle cool the air, which then flows through vents into each office. The air rises naturally as it warms, escaping via louvers along the clerestory level in the building's double-height atrium. In colder months, air traveling into these shafts is warmed by heat pumps situated in the floor. So basically the complex uses water to cool the external air and use that as AC. It uses passive-downdraft HVAC because of the moderate weather. And the last thing is the clerestory that enables daylight to enter and uses less electricity for lighting.

On the other hand, there are cases that achieve emission/energy use reduction. That sounds more achievable since the requirements are less stringent. The first example is the Bioinnovation Center in New Orleans, LA that achieves 61% energy use reduction. It uses metal sunscreen that protects the facade from solar gain and storms. It was designed under the “highest common denominator”, which means most speculative development (the most ambitious design, contrary to a conservative design). It has LEED gold certification, and some of the specifics of the building are shown: Front facade faces southwest, which means it receives the extreme impact of the sunlight; Roof drainage required to handle 2 in/15 min or 5 in/1 hr, and it means that better drainage system eliminates the use of a pump. On the other hand, condensation is a challenge, especially on the hot and humid weather of New Orleans (think about intense AC usage). To deal with this issue, the system collects the condensate to irrigate grass and trees, and collecting condensate also ensures a steady supply of potable water, which in turn (indirectly) helps lowering carbon emissions since the city water supply utility is the single largest greenhouse-gas emitter.

The last example of reduced carbon/energy dependency is the Galileo’s Pavilion, Johnson County Community College, Overland Park, KS. It is designed for LEED platinum certification. It has fixed louvers that prevent too much heat gain while still allowing the building to take advantage of the sun. The VRF (Variable Refrigerant Flow) system allows for simultaneous heating and cooling, and a heat pump feeds refrigerant to six fan-coil units servicing the three main zones, while energy-recovery ventilators (ERVs) feed air to the fan coils. (Malone, A. 2013) One ERV provides constant ventilation to each zone and a backup is controlled by CO₂ sensors. The electricity of the building is produced by photovoltaic panels and a wind turbine, and they provide 70% of the need. Also, there are three green walls fed by a rainwater-harvesting system (they are covered by plants and they save HVAC energy/cost).

Performance buildings

Besides the aforementioned cases, three building cases from Greensourcemag are studied as well: Research Support Facility (RSF), New York Times Building, and Regents Hall of St Olaf College. (Measuring Success, 2013)

The orientation of RSF was to maximize daylight and natural ventilation. In doing so, louvers direct sunlight toward the ceiling to create glare-free, indirect lighting. Natural ventilation through operable windows can precool the building on summer nights. Besides that, energy usage reduction can also be achieved by the location of the building. The offices run generally East-West, that is important

because of the direction of sunlight on solar panels and natural sunlight; sunlight can preheat air for future use. On the other hand, cooling is also important, and that is done by evaporative cooling, energy recovery systems and chillers.

Another example is the New York Times Company building. New York Times Company learned about dynamic facade and lighting systems through the Lawrence Berkeley National Laboratory and thus the building uses superclear, low-iron glass to emphasize transparency. Besides that application, the client is also interested in incorporating innovative controls (control systems) and shading offices to reach optimal lighting conditions while minimizing energy consumption. Also, the Under-Floor Air-Distribution system (UFAD) reduces energy consumption and improves comfort. A modeling study based on EnergyPlus simulations showed that, generally, UFAD has a peak cooling load 19% higher than an overhead cooling load and 22% and 37% of the total zone UFAD cooling load goes to the supply plenum in the perimeter and interior, respectively (Schiavon, S.; Lee, K.H.; Bauman, F.; Webster, T.). Data Centers are a prime example of the UFAD application.

The final example is the Regents Hall of St. Olaf College. It has a Hall of Natural and Mathematical Sciences building that is LEED-NC platinum certified and it was built in 2008. It was Designed for “green chemistry”, “The design, development, and implementation of chemical products and processes to reduce or eliminate the use and generation of substances hazardous to human health and the environment.”. The mechanical system was designed to direct fresh air first to non-laboratory spaces then to lab spaces, so the air gets circulated twice before being exhausted, reducing a lot of energy requirements. Also, heat in exhaust air is recaptured before being exhausted to preheat incoming air.

A1- Heat Gain Calculation

Heat Gain at the Experimental Data Center Computer Room

Design Condition Temperature of the Experimental Data Center: 75F (24C)

1. Heat dissipation from the Iceotope solutions (severs)

Quantity of Iceotope solution in the experimental data center: 32

Performance data of an Iceotope Solution obtained from Iceotope Data Sheet online
<http://www.iceotope.com/assets/files/pdfs/iceotope-implementation-guide.pdf>

Total peak AC input power: 21.9kW

$$21.9\text{ kW} \cdot 32 = 2391228.856 \frac{\text{BTU}}{\text{hr}}$$

Where 32 is the quantity of Iceotope solution in the experimental data center

Maximum output temperature for Iceotope solution (server): 50C (122F)

Maximum input temperature for Iceotope solution (server): 45C (113F)

$$\Delta T := 122 - 113 = 9 \quad \text{F} \quad \text{Temperature Difference}$$

$$\text{Flow Rate: } 1 \frac{\text{L}}{\text{sec}}$$

Since the working fluid is water, the mass flow rate is

$$\text{MLR} := 2.20 \frac{\text{lb}}{\text{sec}}$$

$$\text{Specific Heat of Water: } C_p := 1 \frac{\text{BTU}}{\text{F}}$$

Heat Transfer of Iceotope's submersion cooling system:

$$Q_{\text{IceotopeCooling}} := \text{MLR} \cdot C_p \cdot \Delta T \cdot 32 \cdot 3600 = 2283033.6 \frac{\text{BTU}}{\text{hr}}$$

Where 32 is the quantity of Iceotope solution in the experimental data center, 3600 is converting time unit from second to hour.

Assumption:

The server system claims to be up to 90 percent efficient at capturing heat from the submerged servers.

The heat dissipation from the Iceotope solutions:

$$Q_{\text{iceotope}} := \frac{Q_{\text{IceotopeCooling}}}{90\%} \cdot 10\% = 253670.4 \frac{\text{BTU}}{\text{hr}}$$

2. Heat Gain through the Roof

Design choice: light color

$$A_{\text{roof}} := 58 \cdot 106 = 6148 \quad \text{ft}^2 \quad \text{Area of the roof}$$

$$\text{ETD} := 40 - (75 - 75) = 40 \quad \text{From Air Conditioning Principles and Systems P125, Table 6.17(Pita), used 95 F as the maximum design temperature according to example data center location weather report.}$$

R-value of the roof (Same value with example data center)

$$R_{\text{roof}} := 23.12$$

$$Q_{\text{roof}} := \frac{1 \cdot A_{\text{roof}} \cdot \text{ETD}}{R_{\text{roof}}} = 10636.678 \quad \frac{\text{BTU}}{\text{hr}}$$

3. Heat Gain through the Walls

$$A_{\text{wall}} := 58 \cdot 20 \cdot 2 + 106 \cdot 20 \cdot 2 = 6560 \quad \text{ft}^2 \quad \text{Area of the four walls}$$

R-value of the wall (Same value with example data center)

$$R_{\text{wall}} := 18.17$$

$$Q_{\text{wall}} := \frac{1 \cdot A_{\text{wall}} \cdot \text{ETD}}{R_{\text{wall}}} = 14441.387 \quad \frac{\text{BTU}}{\text{hr}}$$

4. Heat Gain through Floors

Since over basement, enclosed crawl space or concrete slab on ground the ETD is 0, The heat gain through floors is 0.

$$Q_{\text{floor}} := 0 \quad \frac{\text{BTU}}{\text{hr}}$$

Total Heat Gain through the Structure (Roof, walls and floor)

$$Q_{\text{Structure}} := Q_{\text{roof}} + Q_{\text{wall}} + Q_{\text{floor}} = 25078.065 \quad \frac{\text{BTU}}{\text{hr}}$$

5. Heat Gain Based on People

$225 \frac{\text{BTU}}{\text{hr}}$ per person From Air Conditioning Principles and Systems P127 (Pita).

Since Data Center considered as a ware house, assume 3 people would stay in the room

$$Q_{\text{people}} := 3 \cdot 225 = 675 \frac{\text{BTU}}{\text{hr}}$$

6. Heat Gain through Lightning

Quantity of lights: 21

Each light rated at 25 W

$$1\text{W} = 3.412 \frac{\text{BTU}}{\text{hr}}$$

$$Q_{\text{light}} := 21 \cdot 25 \cdot 3.412 = 1791.3 \frac{\text{BTU}}{\text{hr}}$$

Total Heat

$$Q_{\text{roof}} + Q_{\text{wall}} + Q_{\text{people}} + Q_{\text{light}} + Q_{\text{iceotope}} = 281214.765 \frac{\text{BTU}}{\text{hr}}$$

A2- Heat Loss Calculation

Heat Loss at the Experimental Data Center Computer Room

Heat Loss: $Q=U \cdot A \cdot TD$

Minimum temperature: 0F

Design Condition Temperature of the Experimental Data Center: 70F (21C)

1. Heat Loss through the Roof

$$Q_{\text{lossroof}} := \frac{1A_{\text{roof}} \cdot (70 - 0)}{23.12} = 18614.187 \quad \frac{\text{BTU}}{\text{hr}}$$

2. Heat Loss through the Walls

$$Q_{\text{losswall}} := \frac{1A_{\text{wall}} \cdot (70 - 0)}{18.17} = 25272.427 \quad \frac{\text{BTU}}{\text{hr}}$$

3. Mechanical Ventilation Heat Loss

$$Q_{\text{lossMV}} := 1.08 \cdot 600 \cdot (70 - 0) = 45360 \quad \frac{\text{BTU}}{\text{hr}} \quad \text{600 is outdoor air flow, calculated in Roof Top Unit Selection}$$

Total Heat loss

$$Q_{\text{loss}} := Q_{\text{lossroof}} + Q_{\text{losswall}} + Q_{\text{lossMV}} = 89246.614 \quad \frac{\text{BTU}}{\text{hr}}$$

A3- Roof Top Unit Selection

Roof Top Unit Selection

Since one ton capacity equals to 12000 BTU/hr

$$\frac{Q_{\text{total}}}{12000} = 23.435 \quad \text{Tons}$$

Assume the total heat needs a roof top runs at its 80% load

$$\frac{23.435}{0.8} = 29.294 \quad \text{Tons}$$

Outdoor-air flow

Assume air flow includes 1/4 of ACH (air change per hour) and 10 % infiltration

$$V := 5810620 = 122960 \quad \text{ft}^3 \quad \text{Volume of the experimental data center}$$

$$\text{Airflow} := \frac{V \cdot 1.1}{60 \cdot 4} = 563.567 \quad \text{CFM (cubic foot per minute)}$$

563.567 CFM would round to 600 CFM in other calculation

	A	B	C	D	E
1	Roof Top Unit Spreadsheet Tool				
2					
3					
4		Manufacturer	Carrier		
5		Model P2,P3,P4,P5050 ,P3,P4,P5040			
6		Nominal Size	50 ton	40 ton	Spreadsheet
7			Draw-Thru	Draw-Thru	Formulas
8		Psych			
9	Air Ent'g Condenser	Chart			
10		Point			
11	Outdoor Air DB	A	95	95	
12	Outdoor Air WB		74	74	(
13	Outdoor Air lb/lb		0.0132	0.0132	H111))
14					
15					
16	Supply CFM	15000	20000	Outdoor Air CFM	600 600
17					
18	Indoor Air DB	B	76.0	76.0	
19	Indoor Air RH		50%	50%	
20	Indoor Air WB		63.3	63.3	
21	Indoor Air lb/lb		0.0096	0.0096	
22					
23	Plenum Rise		0.0	0.0	
24	Plenum Air DB	C	76.0	76.0	=H18+H23 Plenum Air lb/lb
25	=H21				0.0096 0.0096
26					
27	Return Fan Type		NONE	NONE	
28	Return Fan CFM		0	0	
29	Return Fan SP				
30	Return Fan Eff'y				
31	Return Fan BHP	(6350*H30),1)	Return Fan BTUH *	=ROUND((H28*H29)/	
32	Rise	=H32/1.1/(H15-H16)		=1.05*2545*H31/0.9	Return Fan
33	RF Lvg Air DB	D	76.0	76.0	=H33+H24
34	RF Lvg Air lb/lb		0.0096	0.0096	=H21
35					

36							
37	Mixed Air DB	E	76.8	76.6			$=((H16*H11)+((H15-H16)*H34))/H15$
38	Mixed Air lb/lb		0.0097	0.0097			$=((H16*H13)+((H15-H16)*H35))/H15$
39							
40	BT Fan Type		NONE	NONE			
41	BT Supply Fan SP						
42	BT Supply Fan Eff'y						
43	BT Supply Fan BHP						$=ROUND((H15*H41)/(6350*H42),1)$
44	BT Supply Fan BTUH *		$=1.05*2545*H43/0.9$	BT Supply Fan Rise			$=H44/1.1/H15$
45							
46							
47	Entering Air DB	F	76.8	76.6	$=H45+H37$	Entering Air lb/lb	0.0097
48							0.0097
49	Entering Air "h"		29.09	29.01			$=(0.24*H47)+(1061+0.444*H47)*H48$
50	Ln (h)		3.370	3.368			$=LN(H49)$
51	Entering Air WB		63.7	63.6			$=30.9185-39.682*H50+20.5841*H50*H50-1.758*H50*H50*H50$
52							
53							
54	Unit MBH Total		537.0	435.5	Unit MBH Sensible	386.1	336.8
55	Unit MBH Latent				150.9	98.7	$=H53-H54$
56	Coil Leaving Air DB	G	53.4	61.3	$=H47-(1000*H54/1.1/H15)$	Coil Leaving Air "h"	21.14
57							$24.17 =H49-(1000*H53/4.5/H15)$
58	Ln (h)		3.051	3.185			$=LN(H57)$
59	Coil Leaving Air lb/lb		0.0077	0.0087			$=H48-(1000*H55/4840/H15)$
60	Coil Leaving Air WB		51.5	56.5			$=30.9185-39.682*H58+20.5841*H58*H58-1.758*H58*H58*H58$
61							
62	DT Fan Type				2@22.5FC/IGV	2@27FC/IGV	
63	DT Supply Fan SP		1.80	1.80			
64	DT Supply Fan Eff'y		47%	47%			
65	DT Supply Fan BHP		9.0	12.1			$=ROUND((H15*H63)/(6350*H64),1)$
66	DT Supply Fan BTUH *		26723	35927			$=1.05*2545*H65/0.9$

	A	B	C	D	E
1	Roof Top Unit Spreadsheet Tool				
2					
3					
4		Manufacturer	Carrier		
5		Model P2,P3,P4,P5050 ,P3,P4,P5040			
6		Nominal Size	50 ton	40 ton	Spreadsheet
7			Draw-Thru	Draw-Thru	Formulas
8		Psych Chart Point			
67	DT Supply Fan Rise		1.6	1.6	=H66/1.1/H15
68					
69	Duct Rise Allowance		0.5	0.5	0.5
70	Supply Air DB	H	55.5	63.4	=H56+H67+H69 =(0.24*H70)+(1061+0.444*H70)
71	Supply Air "h" 21.64 24.68)*H73 Ln (h)		3.074 3.206		=LN(H71)
72	Supply Air lb/lb		0.0077	0.0087	=H59
73					=30.9185- 39.682*H72+20.5841*H72*H7
74	Supply Air WB		52.4	57.3	2-1.758*H72*H72*H72
75					
76	Avail Space Sens Cap'y	338.6	277.3		=1.1*H15*(H18-H70)/1000 Avail Space Latent Cap'y
77		140.4	88.2		=4840*H15*(H21-H73)/1000
78					
79	Space Sens Load		281	281	
80	Unit XS/Short		20.4%	-1.4%	=H76/H79-1
81	Space Latent Load		39	39	
82	Unit XS/Short		263.9%	128.7%	=H77/H81-1
83					
84					
85					
86	* Fan BTUH includes 5% belt and drive losses				
87	and 90% motor efficiency				
88					
89					
90	LOAD SUMMARY				
91	Space Sensible Heat		281.2	281.2	=H79
92	Duct Rise Allowance		8.3	11.0	=1.1*H15*H69/1000
93					

94	Plenum Heat	0.0	$0.0 = 1.1 * H23 * (H15 - H16) / 1000$
95	Return Fan Heat	0.0	$0.0 = H32 / 1000$
96	Supply Fan Heat	26.7	$35.9 = (H44 + H66) / 1000$
97	Outside Air Sensible	12.5	$12.5 = 1.1 * H16 * (H11 - H18) / 1000$
	MACHINE SENSIBLE	328.7	$340.7 = \text{SUM}(H91:H96)$
98			
99	Space Latent	38.6	$38.6 = H81$
100	Outside Air Latent	10.4	$10.4 = 4840 * H16 * (H13 - H21) / 1000$
101	MACHINE LATENT	49.0	$49.0 = H100 + H99$
102			
103	MACHINE TOTAL LOAD (MBH)	377.7	$389.7 = H101 + H97$
104	TONS	31	$32 = H103 / 12$
105			
106	MACHINE SHR	0.87	$0.87 = H97 / H103$
107			
108			
109			
110	OA WB(K)	296.5	$296.5 = ((H12 - 32) * 5 / 9) + 273.16$
111	OA Part Vapor Press	0.305	$0.305 = H112 - ((14.696 - H112) * (H11 - H12)) / (2830 - 1.44 * H12)$
112	OA Sat'd Vapor Press	0.415	$0.415 = 10^{((10.79586 * (1 - 273.16 / H110) + \text{LOG}(273.16 / H110)) * 5.02808) - 1.05225)}$
113	OA "h"	37.35	$37.35 = 0.24 * H11 + H13$

A4 - Hot Coil Performance Data



Fluid Selection Program
Version 3.9.6 RI

General Information

Project Name : - Coil Item No. :

Coil Tag :

Coil Performance

Model No. : HC12B0807205625022R
Rows / FPI : 2 / 8
Circuiting : Half
Total Cap : 341,863 Btu/Hr
Sens Cap : 341,863 Btu/Hr
Lvg DB/WB : 80.8 °F
Face Velocity : 711.1 SFPM
Standard : 0.27 in. w.c.
Lvg Fluid : 104.4 °F
Fluid Flow : 39.2 GPM

Additional Construction Notes

Coil Coating : None
Casing Mat'l : Galvanized Steel
Casing Type : Flanged
Conn. Mat'l : Copper
Conn. Type : MPT

Fluid PD : 5.21 ft H2O
 Fluid Velocity : 3.01 FPS
 Conn Size : (1) 2.00"
 Dry Weight : 142 Lbs

Date :
 03
 /23/2014
 9:42:01
 am Model
 No :

HC12B0807205625022R

Coil

Construction : 1
 Coils/Bank :
 Fin Type : 12 1.25 x 1.08 Waffle
 Fin Height : 56.25 inch
 Fin'd Length : 72 inch
 Rows Deep : Auto-Select
 Fins/Inch : Auto-Select
 Circuiting : Auto-Select
 Tube Material : Copper

Tube Thick : 0.016 inch
 Fin Material : Aluminum
 Fin Thick : 0.0060 inch
 Allow OppEnd : No

Airside

Airflow : 20000 SCFM
 Altitude : 0 Feet
 Ent. DB/WB : 65.0 / °F
 Cap Req'd : Btu/Hr
 LDB/LWB : 80.0 / °F

Fluid Side

Fluid : Water
 Ent Fluid Temp : 122 °F
 Lvg FLuid : 105 °F
 Fluid Flow Rate : GPM

Special Notes:

Coil is NOT certified by AHRI.
 Performance includes no fouling factor allowance.

PO Box 956 * Paoli, PA 19301 * PH:(800)523-7590
 PH:(610)251-0257 * Fax:(610)251-0805 * Email: sales@coilcompany.com *
 www.coilcompany.com

A5 - Several Other Ways to Recoup Waste Heat

As explained in the Technology section, we also examined other ways of recouping the waste heat from the servers, and they are the thermoelectric device and the absorption cooling system.

Other Liquid Cooling Types

The final technology that is related to data centers is the liquid cooling systems of the servers. The traditional method for cooling servers includes various fan networks. There is a fan attached to each server, which blows the air outside the server rack, which is then managed by a Computer Room Air Conditioner/Handler (CRAC/CRAH) system. There are multiple methods of cooling the air at this point, and eventually cool air is then pumped back into the intakes of the servers.

Air has a very low specific heat capacity, which makes it very inefficient for use in cooling. Water has a very high specific heat capacity, which can be integrated in many different methods for cooling the air directly surrounding the server electronics. Three of the available cooling solutions are Internal Loop Liquid Cooling, RackCDU™ with D2C™ Liquid Cooling that uses hot water liquid cooling for data centers, and RackCDU™ with ISAC™ (In-Server Air Conditioning), which eliminates CRAC (Computer Room Air Conditioner, i.e. HVAC) in the data center.

The first one is Internal Loop Liquid cooling. One of its special functions is lowered fan speeds; lowered fan speeds saves power and reduces noise. The technology is proven useful: the same technology is already cooling more than a million CPUs and GPUs.

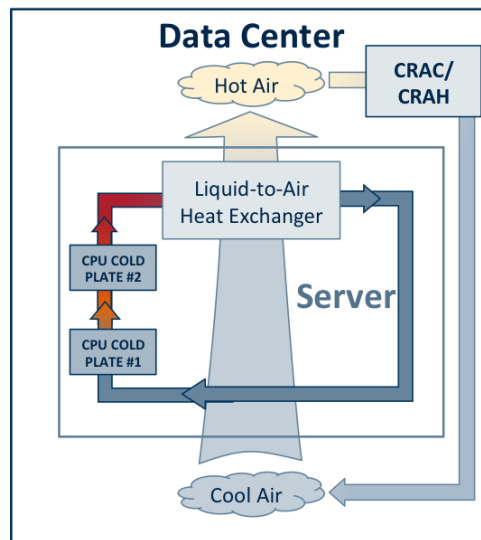

Figure 45: Internal Loop Liquid Cooling

On this diagram, two CPUs are liquid cooled, and cold plates remove the heat from the CPUs and into the flowing fluid. Asetek Internal Loop Liquid coolers operate in low pressure such that pressure-spike related server failure just can't occur. Liquid is circulated through the loop by the pump, and the heat is released by the heat exchanger into the air flowing through the server chassis. A liquid cooled server will typically consume 5-8% less power compared to an air cooled server.

Internal Loop Liquid Coolers are 100% helium integrity tested by Asetek then filled with cooling liquid and factory sealed. Data center operators (and server OEMs) never need to touch the liquid in or refill Internal Loop Liquid Coolers.

The second cooling solution is the RackCDU™ with D2C™ Liquid Cooling. It is a hot water, direct-to-chip, system enables cooling energy savings exceeding 50% and density increases of 5x compared to air cooled data centers. The system uses outdoor ambient air to cool the water returning to the data center. Water leaving the data center is hot enough to enable waste heat recycling, and as we mentioned before, the implementation of the Stirling engine becomes more feasible. There is one that needs to be defined, and that is the Energy Reuse Efficiency (ERE). It is the calculation of (Cooling + Power + Lighting + IT-reuse). In this application, the ERE can be lower than 1, and that is unlike PUE, which measures power usage efficiency.

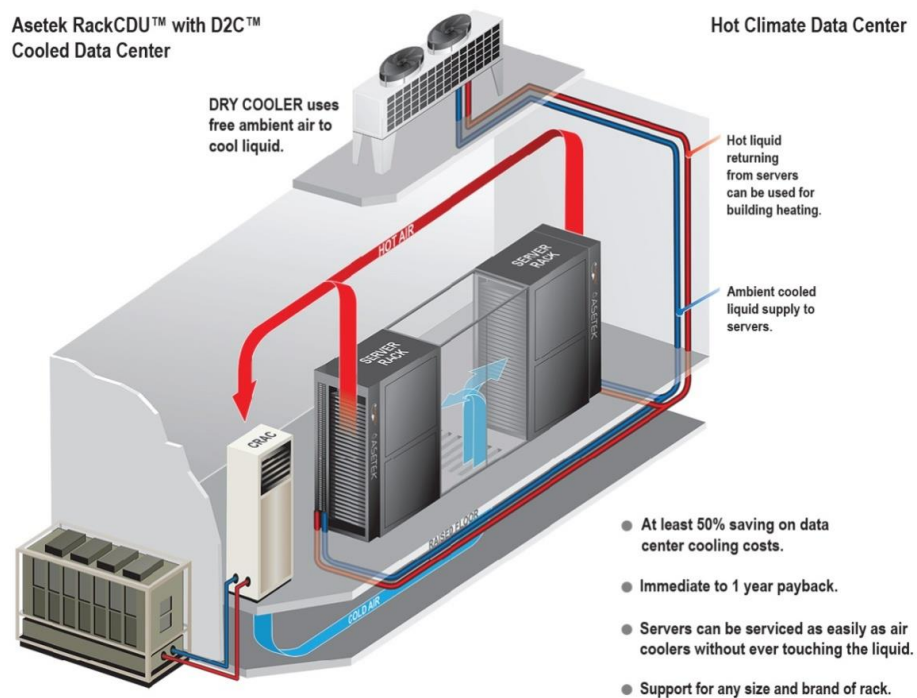

Figure 46: Asetek RackCDU™ with D2C™ Cooled Data Center for Hot Climate

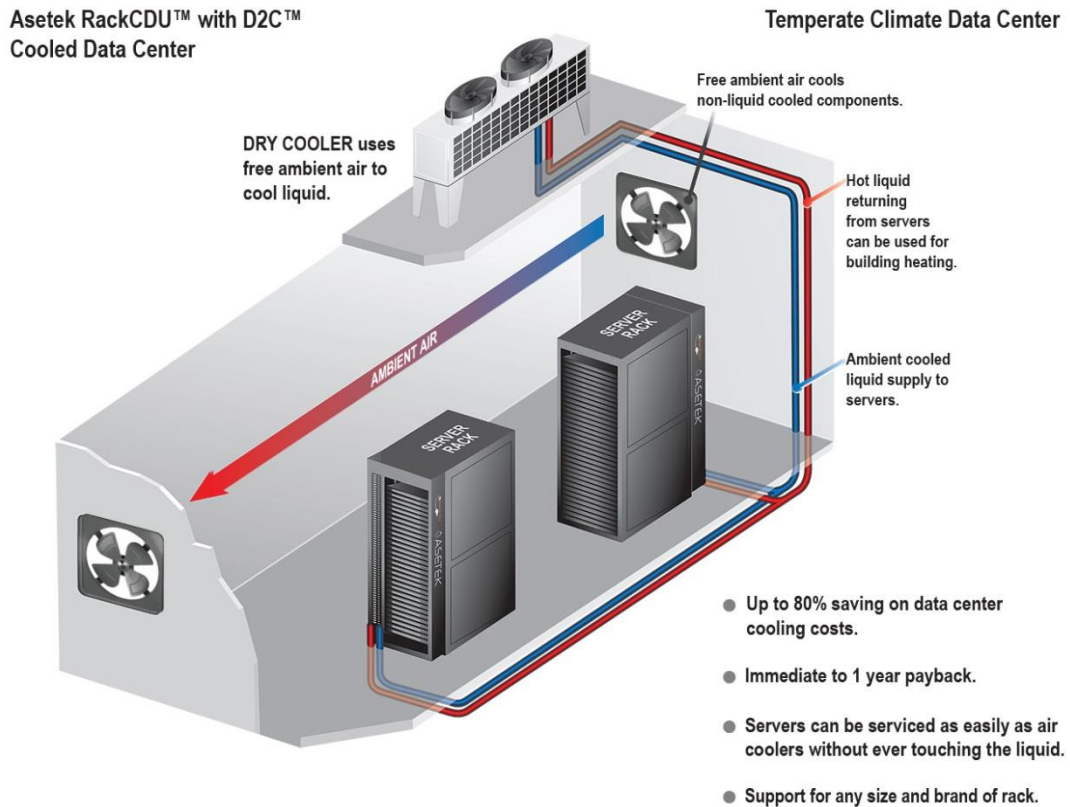

Figure 47: Asetek RackCDU™ with D2C™ Cooled Data Center for Temperate Climate

The third solution is the RackCDU™ with ISAC™ (In-Server Air Conditioning) Liquid Cooling. The special aspect of this solution is that it completely eliminates the need for CRAC (Computer Room Air Conditioning) in the data center because the liquid removes all server heat from the data center. Like D2C, it's hot water, direct-to-chip as well. As the name suggests, the air is sealed inside the server and recirculates rather than exiting and heating up the data center. Each CPU is liquid cooled with Asetek's direct-to-chip cooling technology while a liquid-to-air heat exchanger cools the inside server air that is cooling the rest of the components. The system increases energy efficiency by eliminating CRAC and increasing utilization of free cooling, resulting in cooling energy savings exceeding 50%. It also enables operation in harsh environments by eliminating the need for air temperature and quality control within the data center.

Asetek RackCDU™ with ISAC™ Cooled Data Center

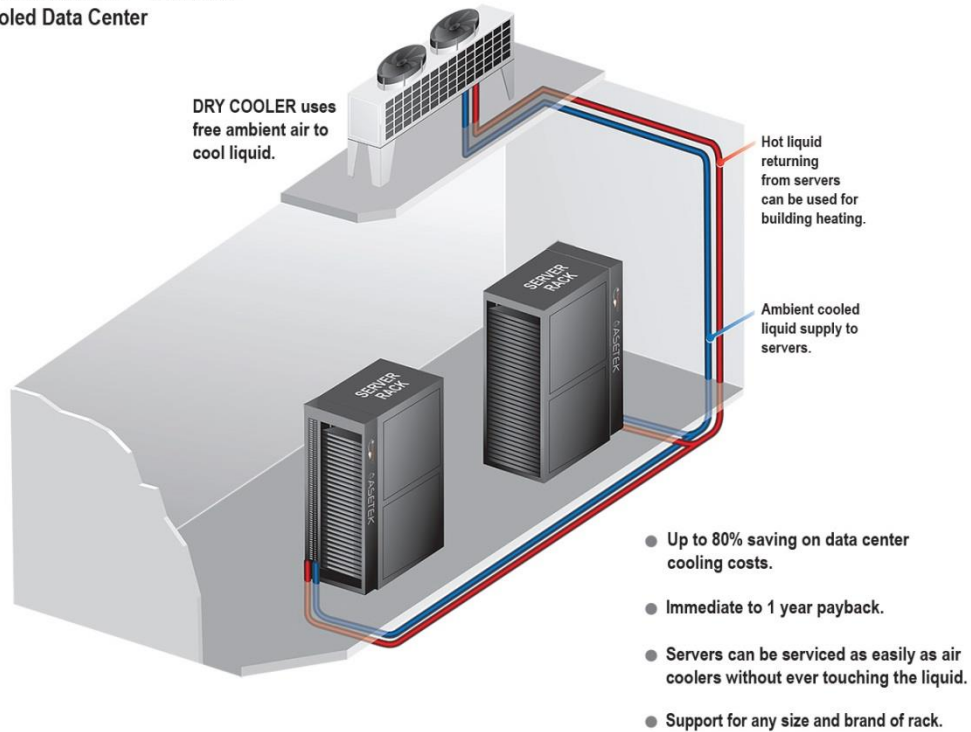

Figure 48: Asetek RackCDU™ with ISAC™ Cooled Data Center

While these three types of liquid cooled servers are far more efficient than traditional air cooled systems, these systems still use air as the fundamental fluid used in contact with the electronic components themselves. We can increase the efficiency further by eliminating air from the equation entirely.

A5.1 - Thermoelectric Device

A thermoelectric device converts heat directly into electrical energy under a phenomenon called thermoelectric effect (or Seebeck effect).

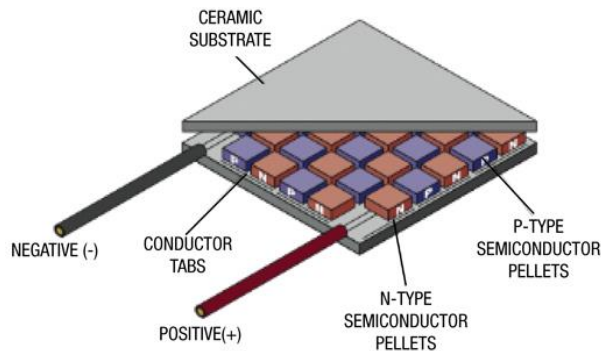

Figure 49: The Design of a Thermoelectric Device

In order to know more about thermoelectric effect, we need to understand several criteria related to that. The first one is the efficiency of the thermoelectric device, which is

$$\eta = \frac{\text{energy provided to the load}}{\text{heat energy absorbed at hot junction}}$$

The ability of a given material to efficiently produce thermoelectric power is related to its dimensionless “ZT” value, or figure of merit:

$$ZT = \frac{\sigma S^2 T}{K}$$

S -> Seebeck coefficient

- $S = -\frac{\Delta V}{\Delta T}$, where ΔV -> thermoelectric voltage difference and ΔT -> temperature difference
- Or $S = \frac{E}{\nabla T}$, where E -> electric field and ∇T -> temperature gradient

K -> thermal conductivity

σ -> electrical conductivity

T -> Temperature

The higher the ZT value is, the more efficient it is at converting heat to electricity. The highest ZT value discovered so far is 2.2, and it is based on the common semiconductor, lead telluride (PbTe).

The effect converts temperature differences into voltage and vice versa. Typically, their efficiency is around 5-8%, which is comparable to Stirling engine applications. On the other hand, it requires less mechanical parts, less maintenance and compact in size.

The highest ZT value discovered so far is 2.2, and it is based on the common semiconductor, lead telluride (PbTe). To increase ZT, researchers typically try to increase a material's electrical conductivity as much as possible while holding down its thermal conductivity. According to an article about research on thermoelectric devices, the thermal conductivity cannot be reduced below the amorphous limit.. Adding thallium impurity levels to PbTe boosted the ZT value to 1.5 because thallium altered the electronic structure of the crystal, thus improving its electrical conductivity. Having said that, using additives which can improve electrical conductivity increases ZT value.

One common thermoelectric device is the thermocouple.

The application of thermoelectric device can be beneficial because it is compact in size, and also it does not have moving parts, thus greatly reducing maintenance. However, it has the most confined temperature range, and thermoelectric generators are only serving appliances where efficiency and cost are less important than reliability, light weight, and small size.

A5.2 - Absorption Refrigeration

Another possibility of utilizing the waste heat is the absorption refrigeration. The following picture shows an ammonia-hydrogen-water system.

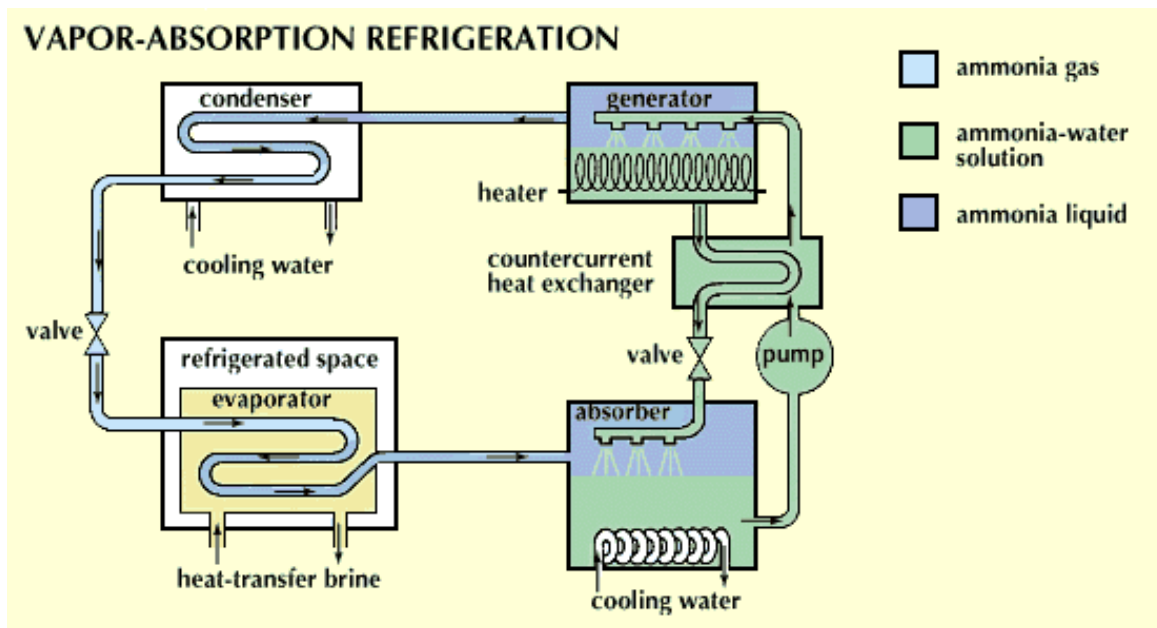

Figure 50: An Ammonia-Hydrogen-Water Absorption Refrigeration System

At first, water is added to ammonia, and they are mixed. As the mixture advances on the cycle, it goes through a heater, where water leaves the cycle and 100% ammonia remains. As the word cycle suggests, water is recycled either at the mixer or at the heater/evaporator. Then 100% ammonia goes to a condenser, where it cools down to liquid phase. Then hydrogen is added to the liquid ammonia, and they are cooled down. The final step involves ammonia going to a storage tank, and the cycle loops back to its starting point.

Absorption refrigeration is more efficient because heat – cooling conversion is more direct than heat – electricity – cooling conversion, also the pumps have fewer moving parts than a Stirling engine; it is more frugal than a compressor; and the application accommodates a much broader temperature

range because the concentration of NH_3 can be varied from 0 – 100% (we can change the boiling point arbitrarily, e.g. boiling pt. at 25 °C @ 30% concentration, and 80 °C (assumption) @ 5% concentration). However, the application involves the most complicated design out of all three options; it requires the largest investment; it imposes several safety concerns (e.g leakage of water, NH_3 (explosion/toxicity), H_2 (explosion)); and absorption refrigeration is only applicable to our project during summer where we need intense cooling, in which case it may not be the most applicable setup to us.

A6 - Pipe Heat Loss Calculation

In order to find out the heat loss of the pipe, a software called 3E plus was used. Three different sizes of the pipe were used; they are in 4 in, 5 in and 6 in.

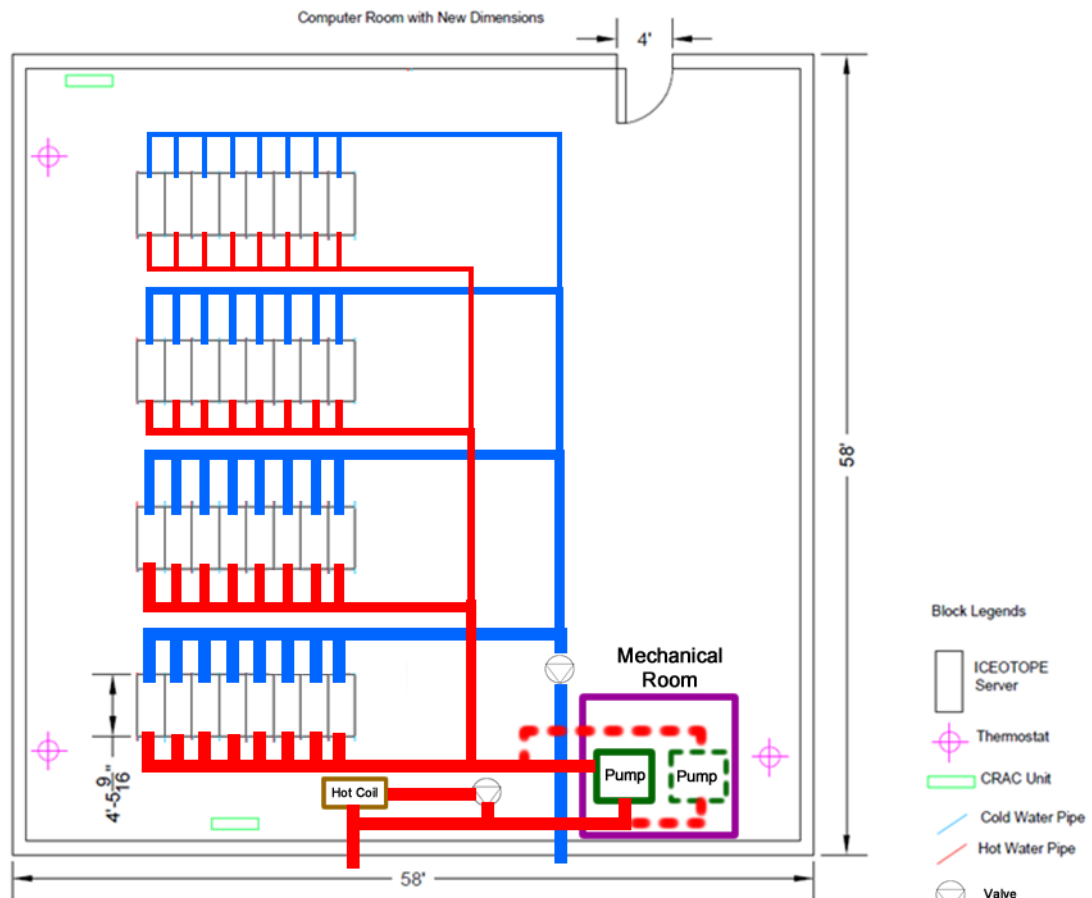

Figure 51: Experimental Computer Room Floor Plan

New server rack width $0.6 \times 8 \text{ rack} = 4.8\text{m}$

Total length of room = 17.7m, new server rack length = 1.36m

$$\frac{17.7 - (4 \times 1.36)}{5} = 2.452\text{m/aisle wide}$$

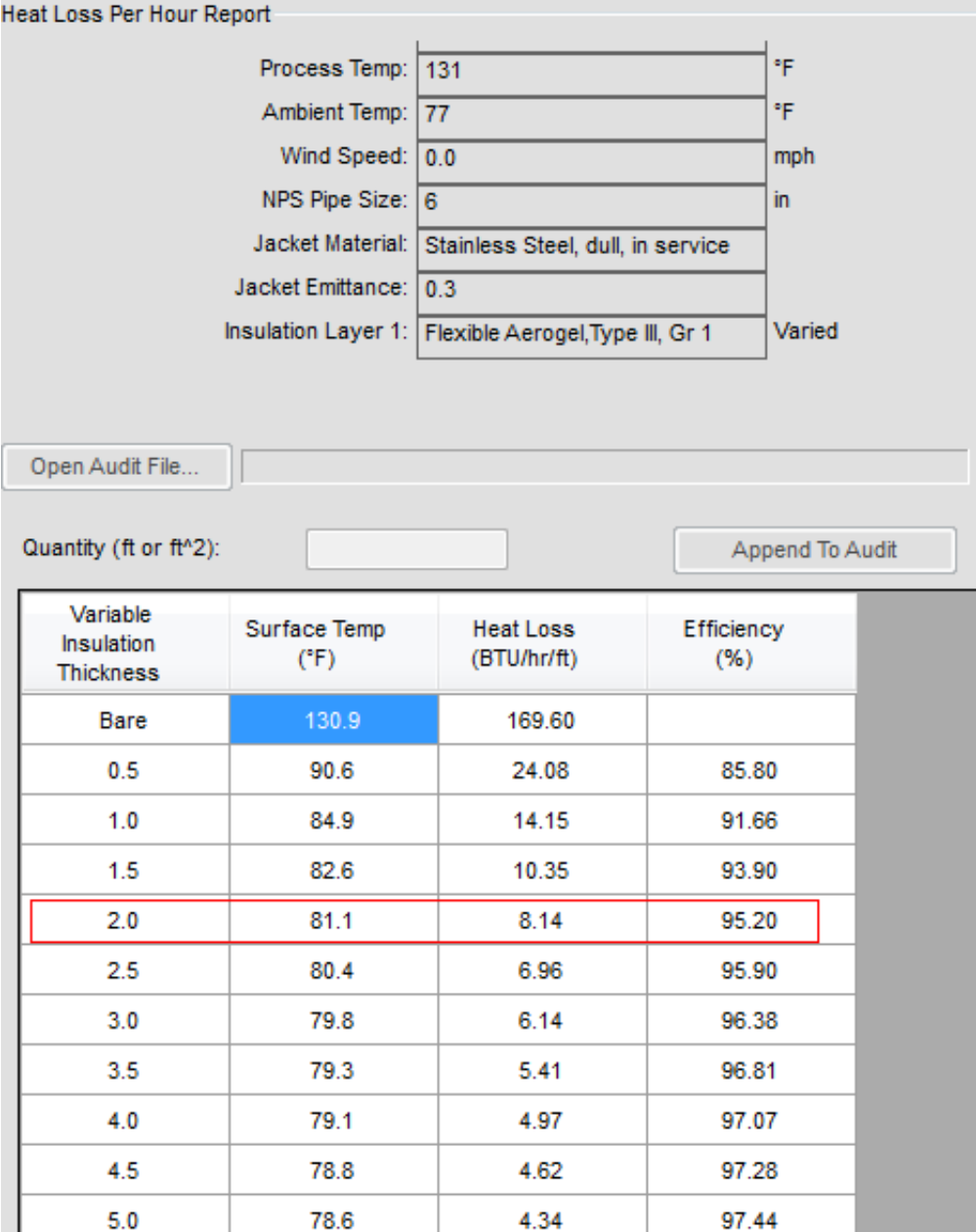

Figure 52: 6 in Pipe Heat Loss Data

Let's pick the 6 in pipe first.

For the 6 in pipe section, total length = 2*aisle + 2* total rack width + 2*rack length + 2*building height

$$2*2.452\text{m} + 2*4.8\text{m} + 2*1.36\text{m} + 2*6.096\text{m} = 29.416 \text{ m} \rightarrow 96.51 \text{ ft}$$

$$\text{Heat loss} = 96.51 \text{ ft} * 8.14 \text{ BTU/hr/ft} = 785.59 \text{ BTU/hr}$$

Then let's pick the 5 in pipe.

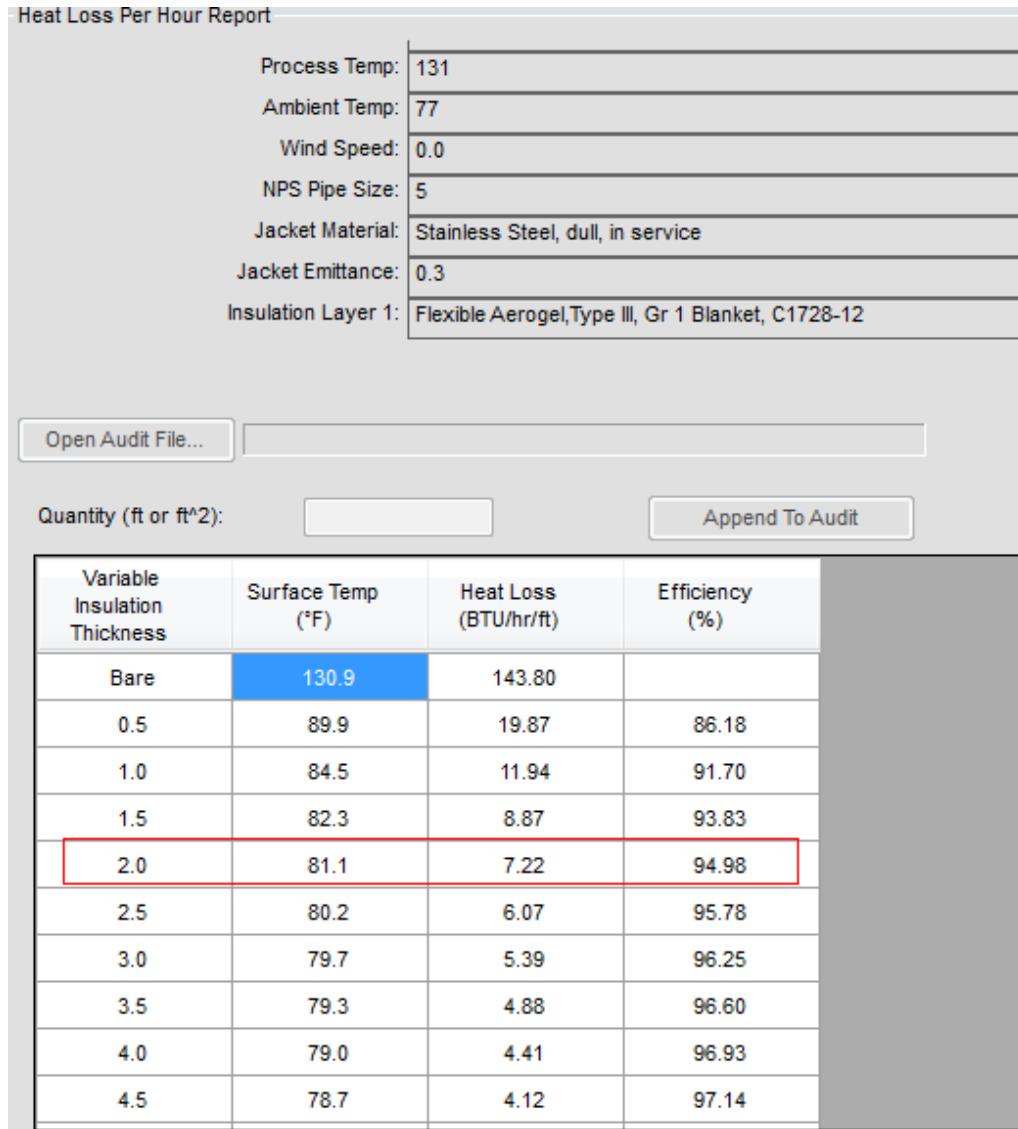

Figure 53: 5 in Pipe Heat Loss Data

Total length = 2*aisle + 2* total rack width + 2*rack length (5 in pipe doesn't have to account for building height)

$$2*2.452\text{m} + 2*4.8\text{m} + 2*1.36\text{m} = 17.22\text{ m} \rightarrow 56.50\text{ ft}$$

$$\text{Heat loss} = 56.50\text{ ft} * 7.22\text{ BTU/hr/ft} = 407.93\text{ BTU/hr}$$

Finally, we pick the 4 in pipe.

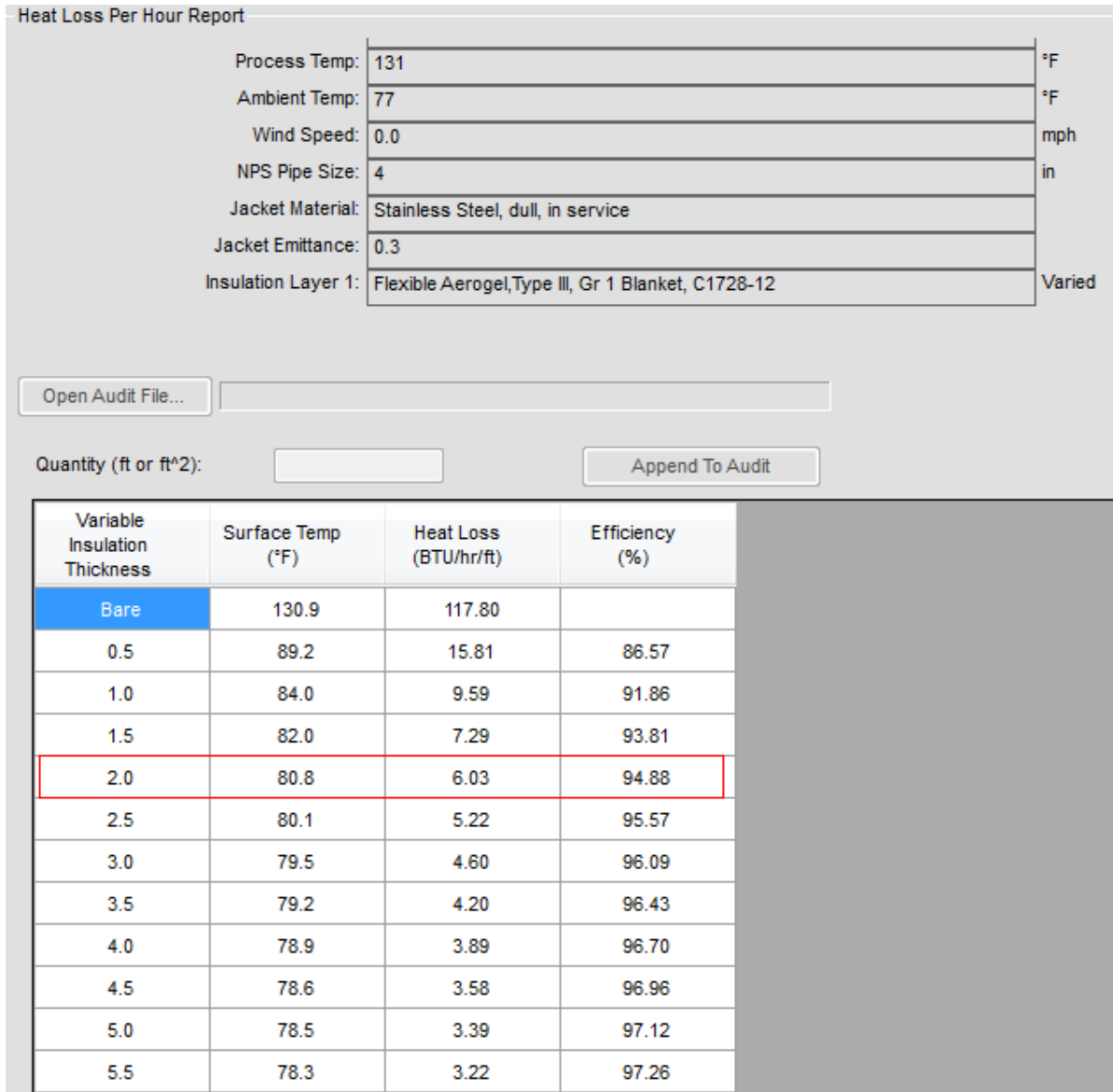

Figure 54: 4 in Pipe Heat Loss Data

Total length = 2 * (2*aisle + 2* total rack width + 2*rack length) because they are two 4 in pipe sections

So the answer is 2 times the previous result = 2*56.50 ft = 113 ft

Heat loss = 113 ft * 6.03 BTU/hr/ft = 681.39 BTU/hr

So the total heat loss = 785.59 + 407.93 + 681.39 = 1874.91 BTU/hr

The reason for picking 6 in, 5 in and 4 in pipe can be seen in the subsequent appendices.

A7 - Stirling Engine Output Calculation

The Stirling engine can dissipate heat to the environment from 0 °C (in winter) (because water freezes at 0 °C) to 33 °C (in summer). The maximum temperature the Stirling engine can get is 50 °C. Add 273 to get the Kelvin temperature.

$$0\text{ °C: } \left(1 - \frac{273}{323}\right) * 600000\text{ W} * 0.30\text{ (efficiency of engine)} * 0.85\text{ (efficiency of generator)} = 23684.2\text{ W} = 23.684\text{ kW (best case)}$$

$$33\text{ °C: } \left(1 - \frac{306}{323}\right) * 600000\text{ W} * 0.30 * 0.85 = 8052.63\text{ W} = 8.053\text{ kW (worst case)}$$

A8 - Flow Rate of the Biggest Section

Accord to the heat equation,

$$Q = \dot{m} C \Delta T$$

Where Q is the amount of heat

\dot{m} is the mass flow rate

C is the specific heat value of the substance

ΔT is the change in temperature (typically in Kelvin)

So if we plug in the values we know,

(Note: 5K is the most conservative range for water because water temperature is ≤ 45 °C for inlet and ≤ 50 °C for outlet)

$$600000 \text{ W (new server IT wattage)} = \dot{m}_{\text{H}_2\text{O}} * 4179 \text{ J/Kg} * \text{K} * 5 \text{ K}$$

$$28.72 \text{ kg/s} = \dot{m}_{\text{H}_2\text{O}}$$

$$\text{And } \dot{m} = \rho \dot{V}$$

P is density of substance

\dot{V} is the volumetric flow rate

$$28.72 \text{ kg/s} = \rho \dot{V} = 1000 \text{ kg/m}^3 * \dot{V}$$

$$\dot{V} = 0.02872 \text{ m}^3/\text{s} * 1000 \text{ L/m}^3$$

$$\dot{V} = 28.72 \text{ L/s}$$

$$28.72 \text{ L/s} \rightarrow 455.2 \text{ GPM}$$

That's the maximum required flow rate of the new system.

$$\dot{V} = VA$$

Where \dot{V} = volumetric flow rate

V = velocity

A = area

So plug in all the credentials,

$$455.2 \text{ GPM} = 7.587 \frac{\text{gal}}{\text{s}} = 1.014 \frac{\text{ft}^3}{\text{s}}$$

$$1.014 \frac{\text{ft}^3}{\text{s}} = V * \pi * \left(3 \text{in} * \frac{1 \text{ft}}{12 \text{in}}\right)^2$$

$$V = 5.16 \frac{\text{ft}}{\text{s}}$$

In the table provided by the sponsor relating pipe size, flow rate and velocity, 6 inch pipe size corresponds to the flow range of 440-700 GPM, which matches our GPM of 455.2 GPM.

Integrated
Design Group

133 Federal Street
Boston, MA 02110
T 617.338.1177
F 617.338.7377
www.idgroupae.com

The following guidelines are to be used for all future jobs. If a project engineer has good reason to deviate, he may show his proposal to engineering. On large piping jobs use computer head loss program.

Hot and Chilled Water Systems (closed)
Schedule 40 Steel Pipe

diagonal *pure H₂O*

Pipe Size (inches)	Flow Range (GPM)	Velocity Range (FPS)	PD (ft/100ft)
½	0 - 1.5	0 - 1.6	0 - 2.8
¾	1.5 - 3.5	0.9 - 2.1	0.7 - 3.3
1	3.5 - 7	1.3 - 2.6	1.1 - 3.6
1 ¼	7 - 14	1.5 - 3.0	1.0 - 3.2
1 ½	14 - 21	2.2 - 3.3	1.5 - 3.2
2	21 - 40	2.0 - 3.8	1.0 - 3.1
2 ½	40 - 65	2.7 - 4.4	1.3 - 3.1
3	65 - 115	2.8 - 5.0	1.1 - 3.1
4	115 - 240	2.9 - 6.1	0.8 - 3.2
5	240 - 440	3.9 - 7.1	1.0 - 3.3
6	440 - 700	4.9 - 7.8	1.3 - 3.1
8	700 - 1,450	4.5 - 9.3	0.8 - 3.2
10	1,450 - 2,400	5.9 - 9.8	1.0 - 2.7
12	2,400 - 3,500	6.9 - 10.0	1.1 - 2.3
14	3,500 - 4,500	8.3 - 10.7	1.4 - 2.3
16	4,500 - 6,500	8.2 - 11.8	1.2 - 2.4
18	6,500 - 8,500	9.3 - 12.2	1.5 - 2.2
20	8,500 - 11,000	9.8 - 12.7	1.3 - 2.1
24	11,000 - 16,000	8.8 - 12.8	0.8 - 1.7

πr² → π(D/2)² *our case*

Figure 55: Table relating Pipe Size, Flow Rate, Velocity and Pressure Drop

Both GPM and velocity are in the lower limit of the range, but because they are still within the range, they are acceptable.

A9 - Pumping and Piping System

Here is a schematic diagram showing the pipe diameters and flow rates across each server rack:

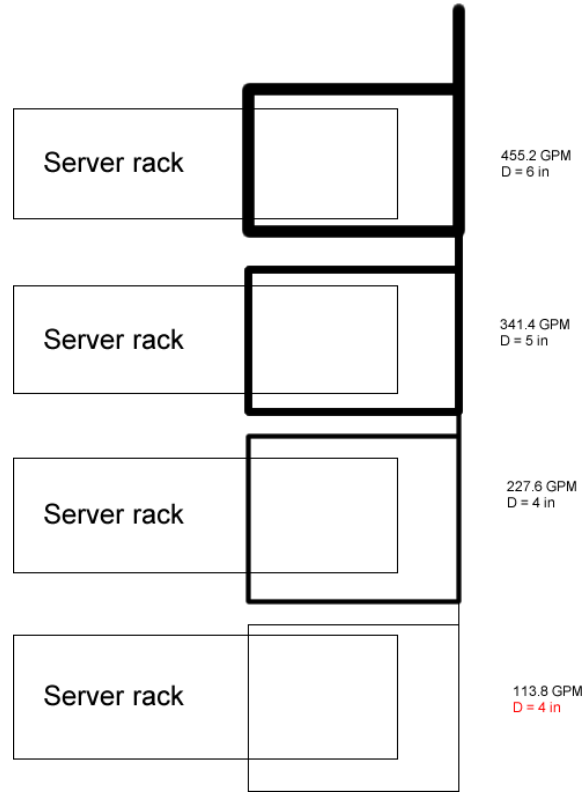

Figure 56: Piping of the Different Modules Schematic

Because the server racks are identical, the flow rate is divided by 4, and the closest rack get 1 (4/4), the second rack get 0.75 (3/4), and so on. Repeat the procedure in the previous section and we check the table provided to see if the results make sense:

	Flow rate	Velocity	Pipe Diameter
Rack 1	455.2 GPM	5.164 ft/s (1.574 m/s)	6 in
Rack 2	341.4 GPM	5.578 ft/s (1.700 m/s)	5 in
Rack 3	227.6 GPM	5.811 ft/s (1.771 m/s)	4 in
Rack 4	113.8 GPM	2.905 ft/s (0.885 m/s) since the pipe diameter is the same	4 in because velocity exceeds the range of 3in

Table 10: Flow Rate, Velocity and Pipe Diameter Relationship

Pressure drop can be calculated by the Darcy – Weisbach equation:

$$\Delta P = f_c \rho \frac{v^2 \Delta x}{2D}$$

Where ΔP = change in pressure

F_c = Darcy friction factor

ρ = density of fluid

v = velocity

Δx is change in length

D = diameter of pipe

In finding the friction factor, a diagram called Moody chart is used.

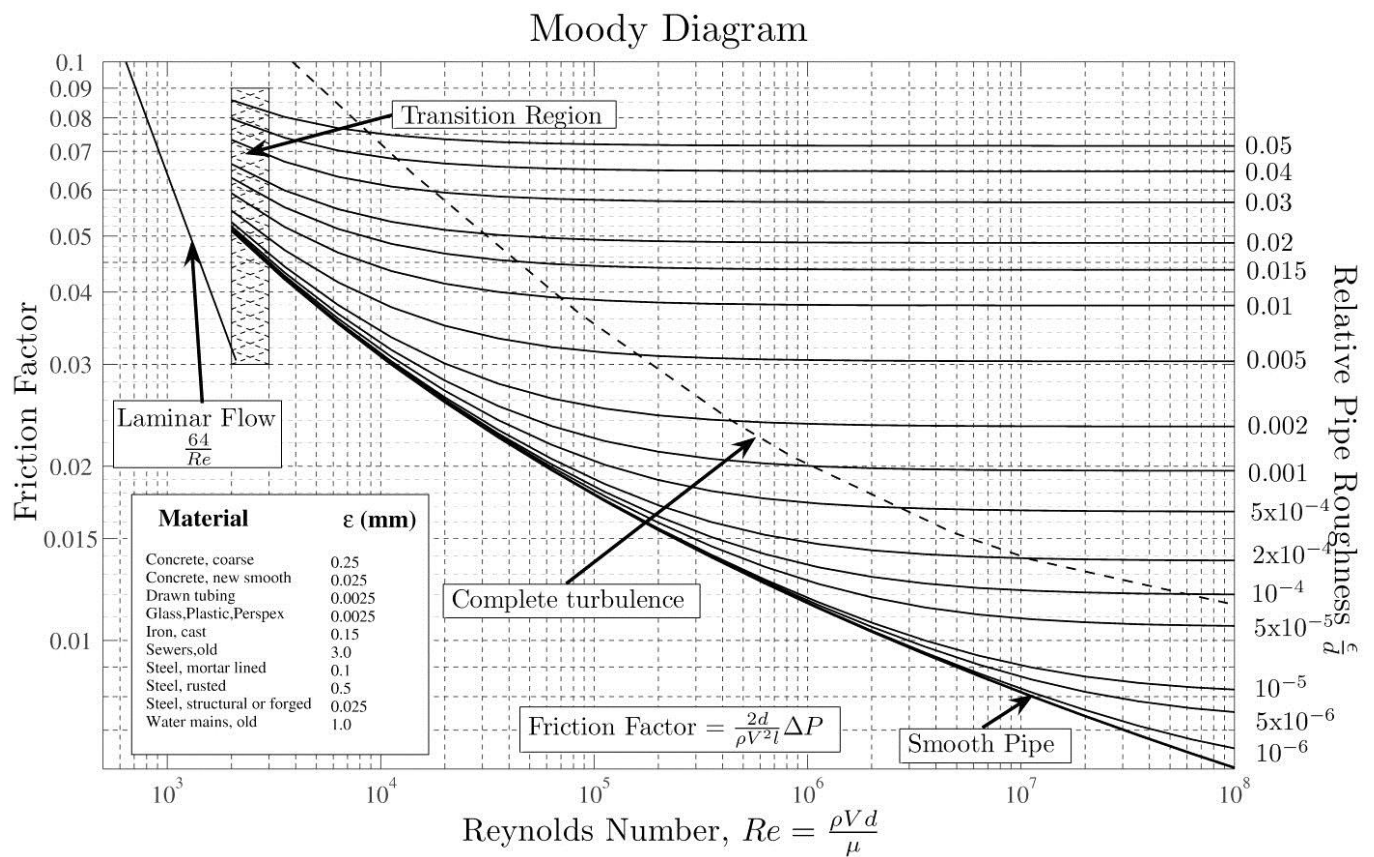

Figure 57: Moody Chart

If we know both the relative pipe roughness and the Reynolds Number (Re), we can see where they intersect and trace the Friction factor to the left.

$$Re = \frac{\rho v D}{\mu}$$

μ = dynamic viscosity of the fluid

In this case, we are using water, so $\rho = 1000 \frac{kg}{m^3}$, V is $5.16 \frac{ft}{s} = 1.574 \frac{m}{s}$, D is 15.24 cm \Rightarrow 0.1524 m, and $\mu = 0.000504 \frac{kg}{m \cdot s}$. So $Re = 475948$.

We picked stainless steel for our pipe, and the absolute roughness (ϵ) is 0.015 mm, and relative roughness is $\frac{\epsilon}{D}$, $D = 15.24 \text{ cm} \Rightarrow 152.4 \text{ mm}$, so relative roughness is $9.84 \cdot 10^{-5}$.

Find the point where they intersect and we get friction factor to be ~ 0.0145 .

$$\text{Then we use } \Delta P = f_c \rho \frac{v^2 \Delta x}{2D}$$

$$\frac{0.0145 \cdot 1000 \cdot 1.574^2 \cdot 14.78}{2 \cdot 0.1524}$$

14.78m is the length of the pipe section

So $\Delta P = 1741.95 \text{ Pa}$.

That's the pressure drop of the pipe section that has 455.2 GPM.

Repeat the same procedures for the smaller sections, and the tabulated results are shown below (Note: they only account for one loop without intersections such as elbows and joints):

	GPM	Reynolds number	Relative roughness	Friction factor	ΔP
Section 1	455.2	474738	0.0000984	0.0145	1741.95 Pa
Section 2	341.4	428373	0.000118	0.0145	2438.41 Pa
Section 3	227.6	356810	0.000148	0.0148	3376.37 Pa
Section 4	113.8	178405	0.000148	0.0155	883.02 Pa

Table 11: Flow Rate, Reynolds Number, Relative Roughness, Friction Factor and Pressure Drop Relationship

Total ΔP (for one single loop) = 1741.95 + 2438.41 + 3376.37 + 883.02 = 8439.75 Pa

There is an equation that related pressure to head:

$$\text{Head (ft)} = \frac{\text{Pressure (psi)} \times 2.31}{\text{Specific Gravity}}$$

The modules are all in parallel so there is only one pressure drop, $\Delta P = 15 \text{ kPa}$

15000 Pa \rightarrow 2.175 psi (Since $1 \text{ Pa} = 1.45 \times 10^{-4} \text{ psi}$)

So head = 2.175 Psi * 2.31/1 (specific gravity of water is ~ 1)

= 5.02 ft

Stirling engine/dry cooler head = 38.95 ft (assumption on Stirling engine)

For piping, we first calculate the head loss of one loop. Our result of 8439.75 Pa turns out to be 1.223 psi.

Head = 1.223 Psi * 2.31/1 = 2.825 ft

However, that's only the head loss of one single loop. We have to take into account that the system has intersections such as elbows and joints that would account for pressure drop. An appropriate way to address that issue is to multiply the gross head loss by 2. Also, the system has a return section that needs to be considered as well, so that number also gets multiplied by 2. So piping head loss = $2 * (2 * (2.825 \text{ ft})) = 11.3 \text{ ft}$.

Attached is a table that lists all the head losses on the water circulation system:

	Head loss
Piping	11.3 ft
Modules	5.02 ft
Stirling engine/dry cooler	38.95 ft (assumption on Stirling engine)

Table 12: Head Loss of Different Pieces of Equipment

Total head = 11.3 + 5.02 + 20 = 55.27 ft

In order to select a proper pump, the team checked out a manufacturer’s website called Bell and Gossett, in there they checked the inline pump series, which was the same as the ones used by the example data center. The guideline of picking the proper pump is to pick the flow rate as in the middle of the curve. In our case, a flow rate curve of ~850 – 900 GPM would have a midpoint similar to our flow rate.

Attached is the performance curve of a Bell and Gossett series 80 In-line pump.

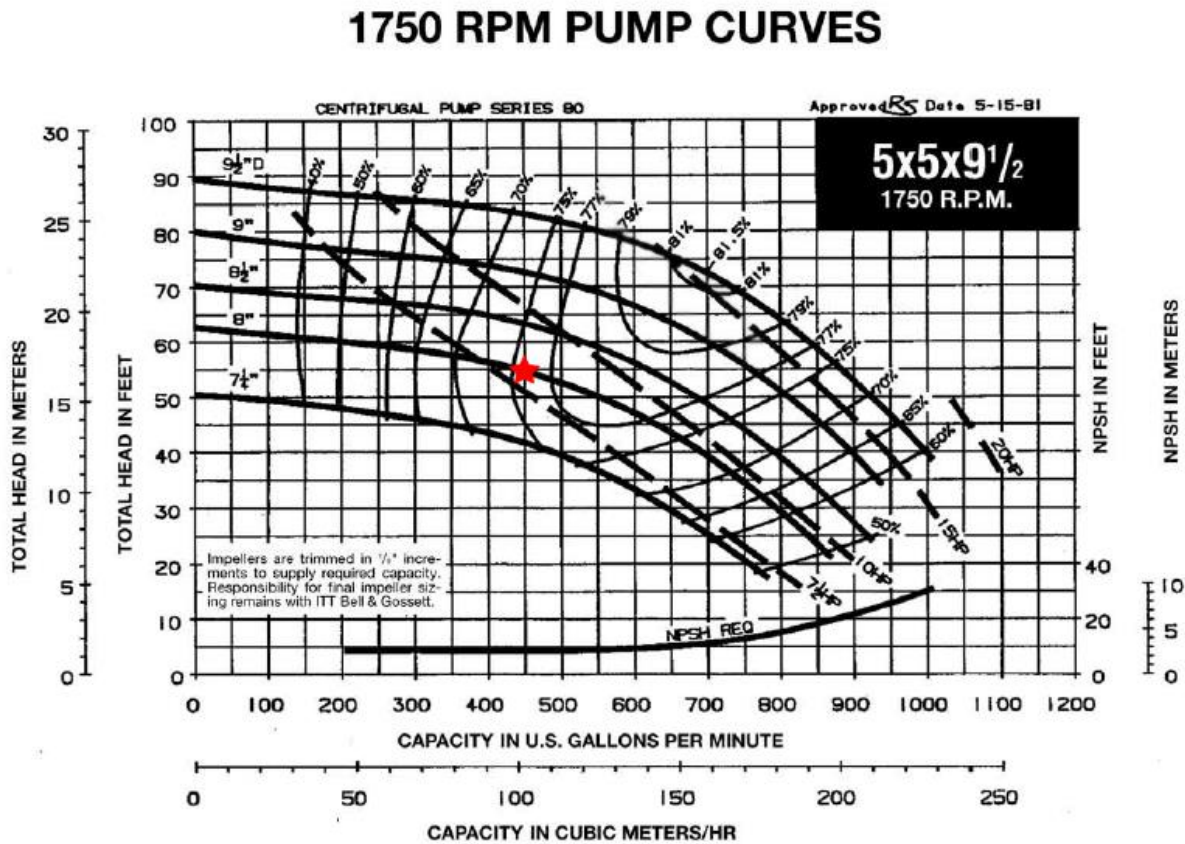

Figure 58: Bell and Gossett Series 80 In-Line Pump Performance Curve

The total pressure drop is 55.27 ft, and the flow rate is 455.2 GPM, so a pump with 8 in impellers would suffice. The pump has a power requirement of 9.5 hp, and converting it into kW,

$$9.5 \text{ hp} \rightarrow 7.08 \text{ kW}$$

$$\text{Motor efficiency is about } 93\%, \text{ so } 7.08/0.93 = 7.612 \text{ kW}$$

That's the energy consumption shown on the electric bill. For redundancy purposes, another identical pump is also connected to the piping system in case the first pump fails.

Structural Design

Structural Analysis Appendix 1/6

Floor Beams

$w_{LL} = 50 \text{ psf (ASCE 7)}, w_{DL} = 34 \text{ psf (30G architectural)}$

$w_{DL} = w_{slab} + w_{part}$

$w_{slab} = \frac{5}{12} \times \frac{150}{1000} = 0.0625 \text{ k/ft}^2 \times A_{slab}$

$\Rightarrow 0.0625 \times \frac{25}{5} = 0.3125 \text{ k/ft}$

$w_{LL} = 50 + 34 = \frac{84}{1.4} \times \frac{25}{5} = 0.42 \text{ k/ft}$

$w_u = 1.4 (0.3125) = 0.4375$

$w_u = 1.2 (0.3125) + 1.6 (0.42) = 1.067 \Rightarrow \text{governs.}$

$M_u = \frac{1.067 (25)^2}{8} = 81.80 \text{ k}$

$F_y = 50 \text{ ksi (ASTM A992)}, \phi = 0.9 \text{ (beams)}$

$Z_x = \frac{81.80 \times 12}{0.9 \times 50} = 21.8 \text{ in}^3$

\Rightarrow Table 3-2 (AISC); Try $W12 \times 19$ ($Z_x = 24.7 \text{ in}^3$)

Recalculate design loading.

$w_u = 1.067 + 1.2 (19) = 10685 \text{ k/ft} \checkmark$

$M_u = \frac{1.067 (25)^2}{8} = 83.58 \text{ k}$

$Z_x = \frac{83.58 \times 12}{0.9 \times 50} = 22.29 \text{ in}^3 < 24.7 \text{ in}^3 \checkmark$

Girder Size

2/6

$$w_u = 1.2 \left[\left(\frac{19}{5} \right) \times 25 + 0.3125 \right] \\ + 1.6 \left[14 \times 25 \right] + 1.2 \left[\frac{19}{5} \right] \\ = 3479 \text{ W/ft}$$

$$M_u = \frac{3479 \times 29^2}{8} = 365.73 \text{ k}$$

$$Z_x = \frac{365.73 \times 12}{0.9 \times 50} = 97.53 \text{ in}^3$$

Try W21 x 48. ($Z_x = 107 \text{ in}^3$)

Update design loads

$$w_u = 3479 + 1.2 (48) = 3536.6 \text{ W/ft}$$

$$M_u = \frac{3536.6 \times 29^2}{8,000} = 371.79 \text{ k}$$

$$Z_x = \frac{371.79 \times 12}{0.9 \times 50} = 99 \text{ in}^3 < 107 \text{ in}^3 \quad \checkmark$$

Beam Deflection Calculations

3/6

$$\Delta_L = \frac{5 w L^4}{384 E I} = \frac{5 \frac{1.0698}{12} (12 \times 25)^4}{384 \times 29,000,000 \times 130} = 0.002 < \frac{12 \times 25}{360} \checkmark$$

$$\Delta_{DL} = \frac{5 \left(\frac{2.3315}{12} \right) (12 \times 25)^4}{384 \times 29 \times 10^6 \times 130} = 7.73 \times 10^{-4} < \frac{12 \times 25}{360} \checkmark$$

Girder Deflection Calculations

$$\Delta_{total} = \frac{5 (12 \times 29)^4 \times \left(\frac{3.535}{12} \right)}{384 \times 29,000,000 \times 359} = 0.002 < \frac{12 \times 29}{360} = 1.0 \checkmark$$

$$\Delta_{DL} = \frac{5 (12 \times 29)^4 \times \left(\frac{0.115}{12} \right)}{384 \times 29,000,000 \times 359} = 0.07 < \frac{12 \times 29}{360} \checkmark$$

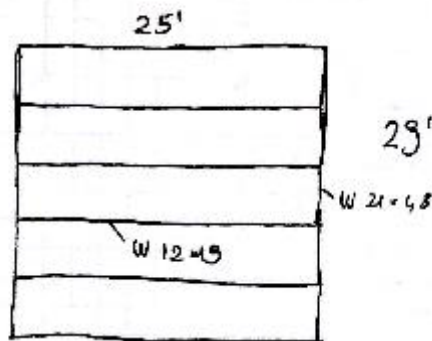

Wind Loads

4/6

$$V_{25} = \frac{100}{1.25} = 80 \text{ mph}$$

$$P_{30} = 0.0027 \times (80)^2 = 17.28 \text{ psf}$$

$$P = C_e \cdot C_g \cdot C_f \cdot C_{pe} = 41.5$$

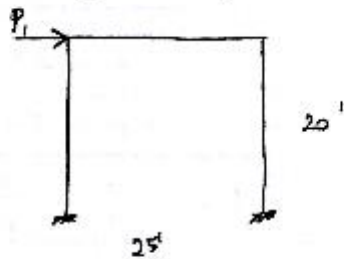

A	P
25×20	41.5

$$\Rightarrow \Sigma P = 10.38 \text{ k (long side)}$$

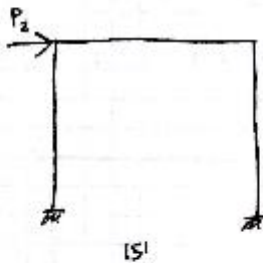

A	P
15×20	41.5

$$\Rightarrow \Sigma P = 6.225 \text{ k (short side)}$$

Earthquake Loads

5/6

$$V = A \cdot S \cdot I \cdot F \cdot W$$

$$= 0.1 \cdot 0.5 \cdot \frac{0.05 \cdot 20}{125} \cdot 1.3 \cdot 1 \cdot W = 0.013 W$$

$$W = \frac{110}{1000} (25 \times 20) = 55 \text{ k}$$

$$V = 0.715$$

$$\frac{h}{b} = \frac{20'}{25'} < 3 \quad \checkmark \Rightarrow F_2 = 0$$

$$W_{1k} = 55 \times 20 = 1,100$$

$$\Rightarrow F_x = 11 \text{ k}$$

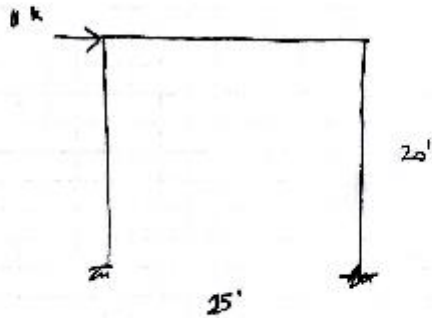

6/6

$$V = A \cdot S \cdot \eta \cdot I \cdot f \cdot W$$

$$V = 0.1 \times 0.5 \times \frac{0.05 (20)}{\sqrt{1.5}} \times 1.3 \times 1 \times 1 \times W$$

$$V = 0.0168 W$$

$$W = \frac{110}{1.422} (15 \times 20) = 33 \text{ k}$$

$$V = 0.5 \text{ k} < \text{wind}$$

⇒ Wind force governs for Needham.

Foundation Design

1

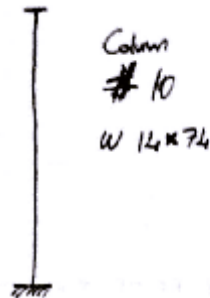

A36 base plates, $f'_c = 3$ ksi footing
 $f'_c = 4$ ksi pedestal

$$A = 21.8 \text{ in}^2, \quad r_x = 6.04 \text{ in}, \quad r_y = 2.41 \text{ in}$$

$$d = 14.2 \text{ in}, \quad b_f = 10.1 \text{ in}$$

$$A_1 = \frac{P_u}{\phi (0.85 f'_c) \sqrt{\frac{A_1}{A_2}}}, \quad \sqrt{\frac{A_1}{A_2}} = 2.0 \text{ for baseplate on footing}$$

$$A_1 = \frac{70.77 \text{ k}}{(0.65)(0.85)(3)(2)} = 21.35 \text{ in}^2$$

$$A_{1, \text{min}} = d \times b_f = 14.2 \times 10.1 = 143.42 \text{ in}^2 \rightarrow \text{governs.}$$

Optimizing Base Plate Dimensions

$$\Delta = \frac{0.35d - 0.8b_f}{2} = \frac{0.35 \times 14.2 - 0.8 \times 10.1}{2} = 5.41 \text{ in}$$

$$N = \sqrt{A_1} + \Delta = \sqrt{143.42} + 5.41 = 17.39 \text{ in}$$

\Rightarrow Say 18 in

$$B = \frac{P_1}{N} = \frac{163.42}{18} = 7.97 \text{ " , say } 8 \text{ "}$$

$$\phi_c = 0.65 ;$$

$$\phi_c P_p = \phi_c \times 0.85 \times f'_c \times A_1 \times \sqrt{\frac{A_2}{A_1}} = 0.65 \times 0.85 \times 3 \times 18 \times 8 \times 2$$

$$\phi_c P_p = (97.36 \text{ k} > 70.77 \text{ k} \Rightarrow \text{ok. } \checkmark$$

Computing Required Baseplate thickness

$$m = \frac{N - 0.95d}{2} = \frac{18 - 0.95(14.2)}{2} = 2.255 \text{ "}$$

$$n = \frac{B - 0.8b_p}{2} = \frac{8 - 0.8 \times 10.1}{2} \Rightarrow \text{negligible}$$

$$n' = \frac{\sqrt{d b_p}}{4} = \frac{\sqrt{14.2 \times 10.1}}{4} = 3.00 \text{ " } \rightarrow \text{governs.}$$

$$t_{\text{req}} = \left[\sqrt{\frac{2 P_c}{0.9 \phi_c \beta N}} \right] = 3.00 \times \sqrt{\frac{2 \times 70.77}{0.9 \times 0.65 \times 18 \times 8}} = 0.53 \text{ "}$$

$$t_{\text{required}} = 0.53 \text{ "}$$

Use $1 \frac{1}{8} \times 8 \times 24$ A36 base plate

with 8×18 concrete pedestal.

b) Try plate 18 x 20 concrete pedestal

$$A_1 = 360 \text{ in}^2$$

$$(18+4)(20+4) = 528 \text{ in}^2$$

$$\sqrt{\frac{A_2}{A_1}} = \sqrt{\frac{528}{360}} = 1.21$$

Recalculate A_1

$$A_1 = \frac{P_n}{\phi 0.85 f'_c \sqrt{\frac{A_2}{A_1}}} = \frac{70.77}{0.65 \cdot 0.85 \cdot 4 \cdot 1.21} > \text{O.K.}$$

Try 13 x 15 plate ; $A = 195 \text{ in}^2$

$$13+6 = 19" \quad , \quad 15+6 = 21"$$

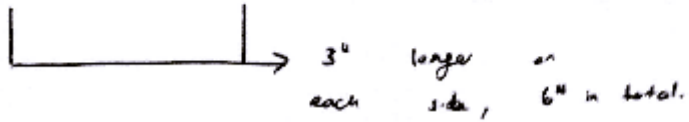

⇒ Use 2 x 13 x 2 # 0 in #36 with 18 x 20 concrete pedestal.

Determine Appropriate Footing Size

$$A_F = \frac{P}{S} ; \frac{70.77 \text{ k}}{3.25 \text{ width}} = 21.78 \text{ ft}^2$$

⇒ Use 24 x 24 in footing

Design of Connections

Grade Steel: W 21 x 68

Column Size: W 14 x 74

Required connection capacity: 71 k

Structural steel grade for W-shapes: A572

Structural steel grade for connection angles: A36

Bolt: $\frac{7}{8}$ " ϕ , A325-N in standard holes.

$$\phi R_n = \phi F_u A_b ; (F_u = 54 \text{ ksi for A325-N})$$

$$\phi R_n = 0.75 \times 54 \times \frac{\pi}{4} \left(\frac{7}{8}\right)^2$$
$$= 24.3 \text{ k per bolt.}$$

$$\# \text{ of bolts} = \frac{V_u}{\phi R_n} = \frac{71}{24.3} = 2.92$$

\Rightarrow Use 3 bolts (3" spacing, $1\frac{1}{2}$ " edge distances)

Checks:

Bearing on Grade Web

$$t_w = 0.430 \text{ in for W 21 x 68}$$

$$\phi R_n = \phi 1.2 L_c t F_u \leq 0.24 d_b t F_u$$

$$L_c = 3 \times 2 + 2 \left(1\frac{1}{2}\right) = 9 \text{ in}$$

$$\rightarrow \phi R_n = 0.75 \times 1.2 \times 9 \times t \times F_u = 8.1 t F_u \text{ (bearing)}$$

$$\phi R_n = 0.75 \times 2.4 \times 3 \times t \times F_u = 16.2 t F_u \text{ (tearing)}$$

$$\text{Total} = (16.2 + 2 \times 8.1) (t F_u) = 24.3 t F_u$$

$$24.3 \phi F_u \geq \frac{71^k}{2} \quad \text{②} \rightarrow \text{double-angled connection}$$

$$\rightarrow t \geq 0.46'' \text{ for bolt bearing}$$

2) Shear Yield

$$\phi R_n = (\phi = 1.00) (0.6 F_y) \cdot L \cdot t \geq \frac{71^k}{2}$$

$$\Rightarrow t \geq 0.71'' \text{ for shear yielding}$$

3) Shear Rupture

$$\phi R_n = (\phi = 0.75) (0.6 F_u) (L - n \cdot d_e) t$$

$$d_e = \frac{7}{8} + \frac{1}{8} = 1''$$

$$\Rightarrow \phi R_n = 0.75 \cdot 0.6 \cdot 58 [9 - 3 \cdot 1''] t \geq \frac{71^k}{2}$$

$$\Rightarrow t \geq 0.227''$$

\therefore Bolt bearing governs

$$3 \frac{1}{2}'' \times 3 \frac{1}{2}'' \times \frac{1}{2}'' \quad \Delta$$

3 #325-N bolts with 3'' spacing.

Electrical Room and Computer Room with New Dimensions

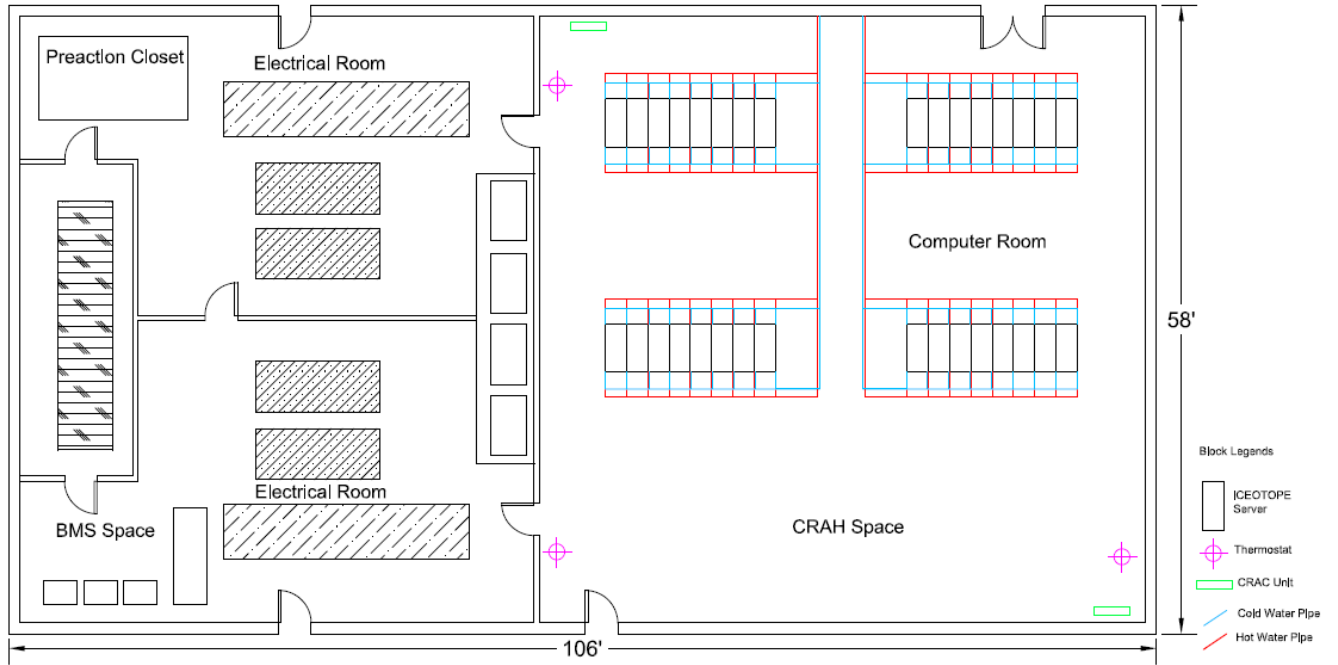

Needham Data Center Electrical and Computer Rooms

