

January 2012

Evaluation of the Erosion Control Methods Implemented by the Panama Canal Expansion Program

Bryan Douglas Lee
Worcester Polytechnic Institute

Tresha K. Melong
Worcester Polytechnic Institute

Zachary D. Lorch
Worcester Polytechnic Institute

Follow this and additional works at: <https://digitalcommons.wpi.edu/mqp-all>

Repository Citation

Lee, B. D., Melong, T. K., & Lorch, Z. D. (2012). *Evaluation of the Erosion Control Methods Implemented by the Panama Canal Expansion Program*. Retrieved from <https://digitalcommons.wpi.edu/mqp-all/3401>

This Unrestricted is brought to you for free and open access by the Major Qualifying Projects at Digital WPI. It has been accepted for inclusion in Major Qualifying Projects (All Years) by an authorized administrator of Digital WPI. For more information, please contact digitalwpi@wpi.edu.



Evaluation of the Erosion Control Methods Implemented by the Panama Canal Expansion Program

Major Qualifying Project

Sponsor:

Autoridad del Canal de Panamá

January 12, 2012

Worcester Polytechnic Institute

100 Institute Road

Worcester, MA 01609

U.S.A

Prepared by: Bryan Lee, Civil and Environmental Engineering
Zachary Lorch, Environmental Engineering
Tresha Melong, Environmental Engineering

Advisor: Jeanine D. Plummer,
Associate Professor, Civil and Environmental Engineering

ABSTRACT

This project evaluated best management practices (BMPs) installed for temporary and permanent soil erosion control in the Pacific sector of the Panama Canal Expansion program. Erosion data were collected at six sites along the canal expansion area and included site assessments and erosion rate measures (erosion bridges, stormwater runoff sampling and RUSLE soil loss estimates). Results showed the sites with hydroseeding had less soil erosion than the sites with silt fences or without BMPs. Additional research showed the benefit of multiple BMPs used in conjunction. The recommended design for the Panama Canal Expansion program is terracing with a slope angle not exceeding 25%, hydroseeding, and silt fencing at the top of each terraced section.

ACKNOWLEDGEMENTS

Our group would like to thank following people for their assistance:

- Our sponsor Mr. Daniel Muschett of the Panama Canal Authority for facilitating our project work.
- Our advisor Professor Jeanine Plummer, of the Civil and Environmental Engineering Department of Worcester Polytechnic Institute, for her guidance.
- Our liaisons at the Panama Canal Authority, Mariaeugenia Ayala G. and Lisbeth Karina Vergara P., who worked closely with us throughout our project.
- Tomás Edghill, Luis Ferreira, Jorge Urriola, Guadalupe Ortega, Denia Barrios and Pastora Franceschi
- The WPI Alumni in Panama for their hospitality and facilitation of our project.
- Lastly our family and friends for their support during the course of the project.

EXECUTIVE SUMMARY

The Panama Canal expansion project involves the excavation of massive amounts of soil for the third set of locks and the widening and deepening of the canal channel to accommodate Post-Panamax vessels. The soil removed is relocated within the project area to other locations. Depending on the material excavated, it is either stored or disposed of at sites specified by the Panama Canal Authority (Autoridad del Canal de Panamá, ACP). Contractors working for the ACP, separate out materials such as basalt rocks (used to make concrete) and clay and unwanted material such as dredged soil. The soil disposal sites have to meet ACP approval with criteria such as site location, storm water management and erosion control.

Erosion is one of the most important environmental aspects being addressed by the ACP Environmental Management and Follow Up Section (Sección de Manejo y Seguimiento Ambiental, IARM) in compliance with the environmental impact study of the expansion project. The excavation and disposal sites are of major concern because the vegetation cover has been removed and the exposed soil is more susceptible to erosion. As such, erosion control practices have been implemented to mitigate the problem of accelerated erosion. These best management practices (BMPs) are classified as either temporary or permanent. Examples of temporary practices are silt fences and sedimentation basins, while permanent practices include hydroseeding and culverts. The contractors responsible for installing and monitoring these BMPs periodically submit progress reports to the ACP with qualitative evaluations of the effectiveness of the erosion control.

This project aimed to evaluate the soil erosion mitigation best management practices installed for temporary and permanent erosion controls for the Pacific sector of the Panama Canal expansion project with a specific focus on the disposal sites. In addition, this project provided recommendations for alternatives or improvements to these controls. In order to achieve these goals, three major objectives were completed. The first was to gather information on the current conditions at sites in the Pacific sector of the expansion project. The second objective was to determine soil erosion rates using historical data and erosion bridge measurements. The third objective was to compare the results for the different sites and different BMPs to assess the advantages and disadvantages of each. By completing these objectives, we were able to recommend an alternative design for temporary and permanent erosion control for the Panama Canal expansion project.

Site assessments consisted of visual inspections, slope measurements and interviews with ACP contractors. Erosion bridges, water quality testing and the Revised Universal Soil Loss Equation (RUSLE) were used as quantitative measures of erosion. Six erosion bridges were installed at each of six sites in the Pacific expansion area to study the change in soil height over time. The bridge's sites were selected based on accessibility and soil types that would allow for the installation of the bridge supports. In addition, our sponsors provided suggestions for areas that would not be disturbed during the time frame of our study.

Of the six sites, four sites had BMPs (silt fencing; hydroseeding; terracing; and hydroseeding with silt fencing), one had natural vegetation (control area) and one had clay soil. Relative soil height at each of the erosion bridges was monitored over 18 days and extrapolated to yearly loss rates.

The sites with hydroseeding had a statistically lower soil loss rate than the site with silt fencing or the site with no BMP. Soil loss rates ranged from 180,400 tons/km²/year for the hydroseeding site to 691,900 tons/km²/year for the site with no BMPs. Estimation of soil erosion was also made using the Revised Universal Soil Loss Equation (RUSLE), which incorporates data on rainfall intensity and soil characteristics. These estimates showed the potential for mitigating soil loss using hydroseeding with or without silt fencing. However, both erosion bridges and RUSLE showed soil loss rates higher than typical for construction sites by one to two orders of magnitude. Longer term data collection is recommended to potentially improve erosion estimates. Further data analysis did not reveal trends with regards to erosion and rainfall intensity or proximity to blasting.

Erosion control BMPs were evaluated based on: short term effectiveness, applicability to different slope angles, applicability to different soil types, effectiveness without additional BMPs, estimated soil loss prevented, and cost of installation and maintenance. Silt fences are effective in the short term and have moderate costs. Hydroseeding is applicable to different slope angles and soil types, does not require additional BMPs to be effective, and prevents soil loss effectively but has high installation costs and is not effective immediately. Terracing prevents soil loss and can be applied without additional BMPs, but has limited applicability to different soil types and slope angles.

Interviews with contractors showed that a combination of erosion control measures is needed to best manage erosion in most cases. Our recommendation was a combination of terracing, silt fences and hydroseeding. The terraces would be approximately 33 m apart, with slopes that do not exceed 25% (14.4 degrees) and silt fences at the end of every terrace on the top of the hydroseeded slopes. This recommendation was for soil types such as the Pedro Miguel formation, which has a mix of sand, silt and clay, which can promote healthy vegetation growth. The estimated total cost for installation and maintenance on a 3,150 m² hillside was \$28,480, with majority of the cost based on the hydroseeding costs.

TABLE OF CONTENTS

ABSTRACT.....	ii
ACKNOWLEDGEMENTS.....	iii
EXECUTIVE SUMMARY	iv
TABLE OF CONTENTS.....	vi
LIST OF FIGURES	ix
LIST OF TABLES.....	xi
1.0 INTRODUCTION	1
2.0 BACKGROUND	2
2.1 History of the Panama Canal.....	2
2.1.1 Early History.....	2
2.1.2 French Involvement.....	2
2.1.3 Panama Canal and the United States of America.....	3
2.2 Description of the Panama Canal.....	4
2.2.1 Physical Characteristics.....	4
2.2.1.1 Panama Canal Locks.....	5
2.2.1.2 Gatún Lake.....	6
2.2.2 Geology	6
2.2.3 Soil Characteristics.....	7
2.2.4 Climate.....	8
2.3 Expansion of the Panama Canal.....	9
2.3.1 New Lock Systems and Retention Basins	10
2.3.2. Expansion of Navigational Channels	11
2.4 Soil Erosion.....	12
2.4.1 Causes of Soil Erosion.....	12
2.4.2 Erosion Control Practices	13
2.4.2.1 Temporary Erosion Control Practices.....	13
2.4.2.2 Permanent Erosion Control Practices	15
2.4.3 Measuring Soil Loss	17
2.4.3.1 Case Study: Erosion Bridge.....	19
2.4.4 Summary.....	20

3.0 METHODOLOGY	21
3.1 Site Assessments	21
3.1.1 Visual Inspections.....	21
3.1.2 Slope Measurements.....	21
3.1.3 Interviews with ACP Contractors.....	22
3.2 Erosion Rates.....	22
3.2.1 Rainfall and Soil Data.....	22
3.2.2 Erosion Bridge Measurements.....	23
3.2.3 Storm Water Runoff Sampling	24
3.2.4 Soil Loss Equation.....	25
3.2.5 Blasting Data	28
3.3 BMP Evaluation	28
4.0 RESULTS AND ANALYSES.....	30
4.1 Site Characteristics	30
4.1.1 Site 1 - Silt Fences	31
4.1.2 Site 2 – Hydroseeding.....	32
4.1.3 Site 3 – Terracing	33
4.1.4 Site 4 – Disposal Site/No BMP	34
4.1.5 Site 5 – Hydroseeding and Silt Fences	34
4.1.6 Site 6 – Clay Soil Area	35
4.2 Soil Erosion Rate.....	36
4.2.1 Soil Erosion Bridge Micro Profiles	36
4.2.1.1 Change in Micro Profiles for Site 1	36
4.2.1.2 Change in Micro Profiles for Site 2	37
4.2.1.3 Change in Micro Profiles for Site 3	38
4.2.1.4 Change in Micro Profiles for Site 4.....	38
4.2.1.5 Change in Micro Profiles for Site 5	39
4.2.1.6 Change in Micro Profiles for Site 6.....	40
4.2.2 Runoff Analysis.....	41
4.2.3 RUSLE Soil Loss Estimates	43
4.2.4 Rainfall versus Erosion Bridge Soil Loss Estimates	47
4.2.5 Statistical Comparison of Erosion Loss Estimates	48

4.2.6 Distance from Blasting	49
4.3 Evaluation of Soil Erosion Mitigation BMPs	51
5.0 CONCLUSIONS AND RECOMMENDATIONS	55
5.1 Conclusions	55
5.2 Site Recommendations	55
5.3 BMP Design Recommendation for Future Sites	56
5.4 Recommendations for Further Study	58
BIBLIOGRAPHY	59
APPENDIX A: CONTRACTOR INTERVIEW QUESTIONS	62
APPENDIX B: RUSLE CALCULATIONS	63
APPENDIX C: GIS MAP OF SOIL TYPES	68
APPENDIX D: SLOPE CALCULATIONS	69
APPENDIX E: ACP SOIL CORE LOGS	70
APPENDIX F: RUSLE DATA	75
APPENDIX G: STATISTICAL ANALYSIS	78
APPENDIX H: BLASTING DATA	81

LIST OF FIGURES

Figure 1 - Cross section of the Panama Canal showing the locations of the locks (Panamacruise.com.pa, n.d.)	5
Figure 2 - Annual precipitation values at ACP rainfall stations near Panama Canal (URS Holdings, Inc., 2007)	9
Figure 3 - Locations of the three components of the Panama Canal expansion program (Wright, 2006)	10
Figure 4 - Cross section of the new locks and their water reutilization basins (Panama Canal Authority, 2006).....	10
Figure 5 - Conceptual locations of the new Atlantic (left) and Pacific (right) locks (Panama Canal Authority, 2006)	11
Figure 6 - A properly installed silt fence retaining run-off for sedimentation and filtration to occur (Carpenter, 2006).....	14
Figure 7 - Overlapping and collapse of a silt fence due to flooding when installed at a concentrated flow (Carpenter, 2006).....	15
Figure 8 - Stream bank showing the use of riprap for erosion control	16
Figure 9 - Stabilization of slope area using gabions (South Fayette Conservation Group, 2008).....	17
Figure 10 - Erosion control bridge (Blaney and Warrington, 1983).....	19
Figure 11 - Slope measurement schematic (side view) showing height, H and distance, D	22
Figure 12 - Schematic of the constructed erosion bridge installed at each site	24
Figure 13 - Slope length measurement schematic (side view) showing GPS measuring points A and B	27
Figure 14 - GIS map showing locations of sites 1 to 6.....	30
Figure 15 - Site 1 with steep slope and no BMP at the time of erosion bridge installation (Photograph by Tomás Antonio Edghill)	31
Figure 16 - Site 1 showing silt fences installed after soil erosion bridge	32
Figure 17 - Soil erosion bridge installed at site 2 which features hydroseeding	33
Figure 18 - Soil erosion bridge installed at site 3, with basalt rocks and plant growth	33
Figure 19 - Soil erosion bridge installed at site 4 with natural vegetation.	34
Figure 20 - Location of soil erosion bridge at site 5 showing hydroseeding.....	35
Figure 21 - Soil erosion bridge located at site 6 showing the clay, basalt pebbles and rill erosion.....	35
Figure 22 - Change in micro profiles for Site 1	36
Figure 23 - Change in micro profiles for Site 2	37
Figure 24 - Change in micro profiles for Site 3	38
Figure 25 - Change in micro profiles for Site 4.....	39
Figure 26 - Change in micro profiles for Site 5	40
Figure 27 - Change in micro profiles for Site 6	40

Figure 28 - Turbidity runoff samples from each site collected during rain event of November 29, 2011.....	41
Figure 29 - Total Suspended Solids in runoff samples from each site collected during rain event of November 29, 2011	42
Figure 30 - Comparison of soil loss from BMP areas (sites 1, 2 and 3) with control area (site 4) and cumulative rainfall data	47
Figure 31 - Comparison of soil loss from BMP areas (sites 1, 2 and 3) with control area (site 4) and rainfall intensity.....	48
Figure 32 - Relationship between ground vibration level (ppv) and separation scaled distance from blasting for each site	50
Figure 33 - Relationship between ground vibration level and scaled distance from blast of each monitoring station	51
Figure 34 - Recommended design of an effective erosion control plan	56

LIST OF TABLES

Table 1 - Vegetative C factor values (Pitt, 2004)	27
Table 2 - Rainfall data for data collection period	44
Table 3 - Percentage soil composition data and soil erodibility (K) values	45
Table 4 - Length-slope data and final LS values	45
Table 5 - Ground covering data and final C values	45
Table 6 - Estimated annual soil loss based on RUSLE equation and erosion bridge data	46
Table 7 - Comparison between distance from blasting and soil loss rate based on erosion bridge data	50
Table 8 - Evaluation of soil erosion mitigation BMPs in Panama Canal expansion area	52
Table 9 - Summary of cost assessment for BMP design recommendation.....	58

1.0 INTRODUCTION

The Panama Canal, which is operated by the Panama Canal Authority (Autoridad del Canal de Panamá, ACP), allows for transit of more than 10,000 ships a year. Ships that can transit the canal are called Panamax ships because they were built within the size limits of the canal locks. The ships that do not fit through the canal are called Post-Panamax ships and in the year 2011, accounted for approximately 37% of the capacity of the world's containership fleet. The expansion of the Panama Canal, which began in 2006, is projected to be completed within six to seven years and involves the construction of a third set of locks that will allow Post-Panamax ships to access the canal. The excavation of the new locks requires cutting into hillsides and sometimes the removal of entire mountain sections. The soil removed during the excavation is transported to storage areas for further use or disposal. These designated areas are classified as disposal sites that will be reshaped and landscaped to accommodate the additional soil. The displaced soil in these areas is usually left exposed to rain until the areas are ready to be repurposed. The absence of vegetation cover in these areas causes the exposed soil to be more susceptible to erosion.

Soil erosion is a major issue because the frequency of rainfall in Panama promotes transport of soil from disposal sites into the canal channel. Increased erosion means the canal channel needs to be dredged more frequently to keep the channel operational. Therefore, erosion is one of the most important environmental aspects being addressed by the ACP Environmental Management and Follow Up Section (Sección de Manejo y Seguimiento Ambiental, IARM) in compliance with the environmental impact study of the expansion project. ACP has implemented temporary and permanent erosion control measures in the expansion areas. They are interested in evaluating these erosion control practices to determine their effectiveness at mitigating soil erosion.

This project evaluated the soil erosion mitigation best management practices (BMPs) installed for temporary and permanent erosion control in the Pacific sector of the Panama Canal expansion program with focus on disposal sites. In addition, recommendations were made for alternatives or improvements to these controls. In order to achieve these goals, three objectives were completed. The first was to gather information on the current conditions at the disposal sites in the Pacific sector of the expansion project. The second objective was to determine soil erosion rates using historical data and erosion bridge measurements. The third objective was to compare the results for the different sites and different BMPs to assess the advantages and disadvantages of each. By completing these objectives, we recommended an alternative design erosion control at future disposal sites for the Panama Canal expansion project.

2.0 BACKGROUND

The Panama Canal has been named one of the Seven Wonders of the World by the American Society of Civil Engineers. The construction of the canal was one of the largest and most difficult engineering feats ever undertaken. The canal, which was completed in 1914, is an important part of international trade, providing a direct connection between the Atlantic and Pacific Oceans. However, in order to increase the capacity of the canal, an expansion project is underway to create larger locks to allow larger ships to traverse the canal. These new locks will be located on the Atlantic and Pacific sides of the canal and include water reutilization basins. The excavation of the new access channels along with the deepening and widening of the existing channels have the potential to cause increased erosion.

This chapter provides background on the history of the canal, the geography and topography of the canal, and the expansion project. Then, the effects of soil erosion in the expansion project areas and best management practices that can be implemented are discussed.

2.1 History of the Panama Canal

The concept of a water passage to connect the Atlantic Ocean and the Pacific Ocean was a desired commodity to many countries due to its ability to shorten international trade routes. Two such countries, both of which proposed plans for a waterway, were the United States and France. This section briefly presents the history of the Panama Canal from the 1500s to 1900s.

2.1.1 Early History

In the sixteenth century, exploration and claiming new found lands for countries was important in the development of a nation. In 1513, Vasco Nuñez de Balboa crossed the isthmus between the Atlantic and the Pacific Oceans through what is now Panama (Panama Canal Authority, 2011). This encouraged Charles I of Spain to attempt to connect the two oceans via a canal to open up avenues of travel previously unavailable to ships (Panama Canal Authority, 2011).

Building a canal from the eastern side of Central America to the west coast was not possible with the technology available in the 1500s. In order to take advantage of the short distance separating the two seas, a railroad was built to transport goods from sea to sea. During the gold rush of 1848, the United States utilized the Panama railroad to transport commercial goods which reinvigorated the interest in having a canal that could cross the isthmus (Panama Canal Authority, 2011).

2.1.2 French Involvement

In 1876, the Geographical Society of Paris formed a committee called the Société Civile to investigate the possibility of an interoceanic passage way (Panama Canal Authority, 2011). After

Lieutenant Lucien N. B. Wyse surveyed the options for different routes in Panama and Nicaragua, a recommendation was made to construct a sea level canal from Limon Bay to Panama City (Panama Canal Authority, 2011).

In 1878, a treaty with Colombia was signed to give the Société Civile exclusive rights to build a canal through Panama and the rights to the canal would return to the Colombian government after ninety-nine years (Panama Canal Authority, 2011). The Société Civile heard fourteen proposals suggesting routes. Ferdinand de Lesseps, the leader of Société Civile, presented a plan for a straight across sea level canal which would follow a similar path as the railroad. This won favoritism and started to be implemented in 1879 (Panama Canal Authority, 2011).

The project proposed by Lesseps was hindered by equipment that was prone to failure and inadequate for the construction of the canal. Tropical diseases such as yellow fever and malaria caused incessant illness and with no effective prevention or treatment methods available many people died (Panama Canal Authority, 2011). Also, poor planning of soil deposit sites resulted in erosion back into the canal when it rained. By 1885, less than a tenth of the project had been completed. After six years, the French government withdrew financial support for the project.

2.1.3 Panama Canal and the United States of America

Following President McKinley's assassination, Theodore Roosevelt became president. In 1902, Roosevelt saw that, "The canal was practical, vital, and indispensable to the U.S. destiny as a global power" (Panama Canal Authority, 2011). President Roosevelt submitted a supplementary report to congress to evaluate the feasibility of the canal in Panama, or if that was not possible, in Nicaragua.

The route through Panama was more favorable to the United States because it would be shorter, straighter, take less time to transit, require fewer locks, and already had a railroad. The U.S. Senate approved a bill for the Panama Canal and the United States purchased all of the assets and concessions in the area from the controlling French company, Compagnie Nouvelle, for \$40 million USD.

On November 3, 1903, Panama declared its independence from Colombia. To maintain U.S. support, Panama granted the United States the Hay-Bunau-Varilla treaty. This treaty granted the U.S. a canal concession to the Canal Zone which was 10 miles wide, 5 miles on either side of the canal line. On February 23, 1904, the treaty was ratified in the U.S. At this time, Panama received \$10 million from the United States as payment for the Canal Zone (Panama Canal Authority, 2011).

On May 4, 1904, the United States began construction on the canal. Housing was built for the increased work force and food was provided. In six months' time, the American labor force tripled and half of the 24,000 man labor force was employed just for the construction of buildings for the work force to use. The Panama Railroad was the lifeline of the canal

construction as it was the least complicated form of transportation for equipment and supplies. However, the project did face challenges. During the first year of construction on the canal, nearly all of the American work force contracted malaria. Mosquito eradication programs were started to prevent worker sickness. Another obstacle to overcome while building the canal was relocating several native villages and towns set in the Canal Zone. These towns included Santa Cruz, Ahorca Lagarto, Cruce and several others. Many inhabitants were relocated for the creation of Gatún Lake, an artificial lake created to provide water to the locks.

The canal was proposed to be only 150 feet wide for nearly half its length. This was seen by engineers as too narrow and dangerous. Placing locks in the canal would make the passageway safer and less expensive than if the canal was built at sea level. Major changes in design were made during construction to allow for easier and safer travel. Such changes included the widening of the Culebra Cut from 200 feet to 300 feet and an increase in size of the lock chambers from 95 to 110 feet long. The canal was completed in 1914. In 1977, the treaty with the United States for the turnover of the canal to the Panamanian government was signed. Transfer of the canal administration and the areas previously assigned to the United States as military bases was completed in 1999. The canal has had over 800,000 vessels pass through its waters to date.

2.2 Description of the Panama Canal

The Panama Canal cuts through one of the narrowest saddles of the isthmus that joins North and South America to provide a direct route between the Atlantic and Pacific Oceans. The canal route is approximately 80 km in length and uses a system of locks in order for ships to traverse this continental divide. The locks raise or lower ships from the sea level of either the Atlantic or the Pacific Oceans, to the level of Gatún Lake which is 26 meters above sea level. The Continental divide is formed by a central spine of mountains and hills and two-thirds of the approximately 500 rivers in Panama flow into the Pacific Ocean. These rivers also provide a constant supply of water to Gatún Lake. This section provides a description of the locks and the physical characteristics of the canal.

2.2.1 Physical Characteristics

The original three sets of locks are the Miraflores, Pedro Miguel and the Gatún locks, named after the towns where they were built. From the Pacific Ocean, the first set of locks is the Miraflores locks which reside in Panama City and transport ships through the elevation difference between the Pacific Ocean and Miraflores Lake. Continuing north, the second set of locks is the Pedro Miguel locks which are located in Pedro Miguel and transport ships through the elevation difference between Miraflores Lake and Gatún Lake. After traversing Gatún Lake, the final set of locks is the Gatún locks which transport ships through the elevation difference between Gatún Lake and the Caribbean Sea. The locations of these locks are shown in Figure 1, which is a cross section of the canal highlighting the changes in elevation at each lock.

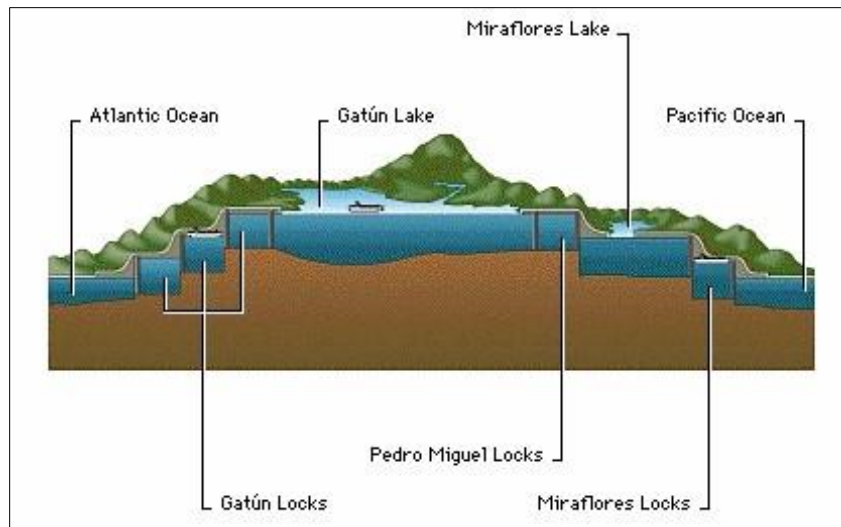

Figure 1 - Cross section of the Panama Canal showing the locations of the locks (Panamacruise.com.pa, n.d.)

The lock chambers, which are steps along the canal, are each 33.53 m wide and 304.8 m long. The maximum dimensions of vessels that can traverse the canal, also known as Panamax, are 32.3 meters in width, 12 meters tall in tropical fresh water and 294.1 meters long (depending on the type of ship). The water used for raising and lowering of the ships in the locks is provided by Gatún Lake. The water in the locks is gravity fed from the lake due to its raised elevation and is channeled through culverts to each lock chamber. Each lock chamber requires 101,000 m³ (26.7 million gallons) from Gatún Lake to fill it from the lowered position to the raised position; the same amount of water is drained from the chamber to lower it again.

The narrowest portion of the canal is called the Culebra Cut, which cuts through the rock and shale of the Continental Divide. The Culebra Cut extends from the north end of the Pedro Miguel locks to the south edge of Gatún Lake in Gamboa. It is estimated to be approximately 13.7 km long.

2.2.1.1 Panama Canal Locks

The Miraflores locks lift or lower vessels in two stages within the lock totaling 16.5 m, allowing them to transit to or from the Pacific Ocean port of Balboa. These lock gates are used to overcome the elevation difference between Miraflores Lake and the Pacific Ocean (Goethals, 1911). The lock gates at Miraflores are the tallest of the three, which is due to the extreme tidal variations that take place in the Pacific Ocean such that the ships must be raised 13.1 m (43 ft) at extreme high tide versus 19.7 m (64.5 ft) at low tide. The tidal variation on the Atlantic coast is far less. The Miraflores locks are slightly over one mile long from beginning to end (Headquarters, 2007). Three large culverts are embedded in the side and center walls and are used to carry the water down from Miraflores Lake to fill the locks.

The Pedro Miguel locks link the artificial Miraflores Lake and Culebra Cut, also known as Gaillard Cut, and were the second to be constructed in 1911. These locks raise or lower ships a total elevation of 9.5 m and are classified as a one-step process. The Gatún locks are the first set of locks on the Atlantic entrance of the Panama Canal. The series of three lock chambers raise or lower ships an elevation of 25.9 m.

2.2.1.2 Gatún Lake

Gatún Lake is an artificial lake built between 1907 and 1913 by the construction of a dam that flooded the lower reaches of the rivers Chagres, Ciri Grande, Trinidad, and Gatún. In forming Gatún Lake, an area of 45,000 hectares was flooded. Based on the landscape of the flooded valleys, the lake is deeper in the northwest area, with depths of 25 meters close to the Gatún locks. The dam is 2,286 meters (7,500 feet) long measured along the top, 640 meters (2,100 feet) wide at the base, and extends 121.3 meters (398 feet) deep through the water surface (Goethals, 1911). Gatún Lake has an area of 425 km² (164 square miles) at its normal level of 26 m (85 ft) above sea level and stores 5.2 cubic kilometers (1.83 x 10¹¹ ft³) of water. This operational level is controlled by a hydraulic spillway which is located on the west of the Gatún locks which has an outflow into the lower course of the Chagres River and then in turn spills into the Caribbean Sea. This lake covers approximately 32.7 km of the overall distance of the Panama Canal (Bennet, 1915). The lake was established to provide the millions of gallons of water necessary to operate the Panama Canal locks and provide drinking water for Panama City and Colon.

2.2.2 Geology

On a regional scale, there is a well-defined sedimentary basin in the area of the Panama Canal. This basin extends from the Pacific to the Caribbean, across the Isthmus, forming an interconnected wall of thin and elongated valleys, which facilitated the excavation of the canal channel. The geological layering is dominated by sedimentary rocks such as limestone, sandstone and clay and those of volcanic origins such as igneous, extrusive, basalt and limestone deposits. The majority of the volcanic type of geological layering is found on the Pacific side (URS Holdings, Inc., 2007). The purpose of this section is to identify and describe the geological layers found in each sector of the Panama Canal area.

There are nine dominant rock layers found in different sectors of the Panama Canal area. The oldest layer is the Gatuncillo formation which consists of fine granular deposits interspersed with limestone. Next is the Panama formation with mainly andesite agglomerates in fine grain tuffs. Third is the Las Cascadas agglomerate which contains fine grain agglomerate and soft tuff. The Culebra formation follows as a marine sequence that contains carbonous schist, lignite, alluvium mudstone and conglomerates. Next is the La Boca formation which has very similar characteristics as the Culebra formation. The sixth formation is the Cucaracha which contains massive bentonic clays, sandstones, conglomerates and ash flows. The last two formations in the sequence are the Pedro Miguel and Gatún formations. The Pedro Miguel formation, which is

usually hard and dense, is interconnected with the La Boca formation and has pyroclastic origins. The Pedro Miguel formation has large masses of basalt and well-cemented conglomerates. The Gatún formation is the most significant layer and is composed of medium to very fine grain calcereous or marlicious mass, with very little sandstone, but with conglomerates of small rocks and alluvia. The Gatún formation is covered and partially overlapped by the Chagres formation in the Caribbean sector. The Chagres consists of fine grain sandstone and alluvial fragments. The Pacific sector is dominated by the La Boca, Chagres, and the Cucaracha formations, which are mostly conglomerates that require blasting during excavation. The Atlantic sector has the non-differentiated sediments, Gatun formation and Bull clay (base material of the Chagres sandstone formation) (URS Holdings, Inc., 2007).

2.2.3 Soil Characteristics

The geological formations discussed in the previous section presented the parent material for the soils that are found in the Panama Canal area. Acidic soils are dominant due to the volcanic origins of the igneous conglomerates. The types of soils found in the area influence drainage, fertility, and subsequently erosion in the canal. Therefore, this section provides an identification and description of the types of soils and how they are classified by the ACP.

The ACP Geotechnical Department identifies four main types of acidic soils found in the area. The first type is the ultisols, which are acidic, infertile soils, most of which have lost their top layer by erosion. The typical soil profile has two to three horizons, including ocrico, umbrico and argilic. Due to the erosion of the surface horizons, the argilic horizon subsurface becomes exposed. This horizon is an accumulation of clay that is much more leached and acidic than the ocrico and umbrico horizons (URS Holdings, Inc., 2007).

The second soil type is the alluvial soils that are found on the flood plains of the rivers Chagres, Gatún, Chilibre, Gatuncillo, and their tributaries. The alluvial soils have only one horizon that consists of a few stones. They are less clayey and more fertile than ultisols. They are classified as entisols because they originate from the very recent alluvial plains and have no defined horizons in their soil profile (URS Holdings, Inc., 2007).

The third soil type is the sedimentary origin soils that are from the Gatún, Gatuncillo, Caraba and Bohio formations. This soil type is less acidic and has greater levels of organic matter. It is the most fertile of all the soil types in the Panama Canal area, but it has a greater capacity for erosion due to the low aluminum content (URS Holdings, Inc., 2007).

The fourth soil type is the anthropic soils, which is also classified as entisols because they are derived from the recent formations and do not have defined horizons in the soil profile. There is also a greater concentration of algae, due to the deposit of dredged materials from the Gatun Lake. The influence of human activities makes it difficult to give a detailed description due to the variability of deposited materials (URS Holdings, Inc., 2007).

Soils in the Panama Canal expansion area are also classified according to their capacity and capability for uses in the construction of the canal. The capacity for use of the soils is determined according to factors such as slope, erosion, effective depth, texture, stone content, drainage and fertility. The best soils are those of Class I because they have no restrictions on their use. The higher classification numbers indicate more restrictions on the use of the soil. Therefore, Class VIII soils would not be used for any other activities pertaining to the building of the locks except protection (sealant for new access dam to the third set of locks). An example of a Class VIII soil is clay because it has poor drainage and fertility. Soils with a higher usage capacity are the alluvial type soils (Classes III and IV), plains and soils of limestone origins (URS Holdings, Inc., 2007).

2.2.4 Climate

The Panama Canal is located on the narrow and low Isthmus of Panama. The potential for erosion of the existing channels and those being excavated is dependent on the climate and geography of the area. Panama has a tropical climate. The average temperature for 2010 was 26.4°C (79.5°F) with a high of 34.5°C (94.2°F) and a low of 8.7°C (47.8°F), as recorded by the Tocumen weather station. Temperatures are higher on the Caribbean side than the Pacific side (Meditz and Hanratt, 1987).

Locally, three types of climates are experienced in the Panama Canal area: very humid tropical climate, humid tropical climate, and tropical grass lands climate. The very humid tropical climate is found to a limited extent in the northern end of the Panama Canal area. It is defined by abundant rainfall all year round, with the driest month of February usually having more than 60 mm of rainfall. The humid tropical climate covers the entire area and is found over the Atlantic area and a large portion of the Pacific sector. This type of climate is characterized by an annual rainfall greater than 2,500 mm and a dry season that lasts for 3 months from January to March. The annual average temperature ranges between 24°C and 26°C. Lastly, the tropical grass lands climate is found on the Pacific side, with annual rainfall below 2,500 mm and the median temperature of the coolest month (November) is 18°C (URS Holdings, Inc., 2007).

Precipitation usually occurs in the form of rainfall. The annual average precipitation recorded by ACP stations within or near the Panama Canal area (Limon Bay, Gamboa and Balboa) varies between 1,891 mm and 2,787 mm. Rainfall mostly occurs during the wet season from May to November. The cycle of rainfall depends on the moisture from the Caribbean Sea deposited by the north and northeast winds and the Continental divide, which acts as barrier for the Pacific lowlands. In general, rainfall occurs more frequently on the Caribbean side than on the Pacific side of the Continental divide. Figure 2 shows the typical precipitation characteristics of the region from 1996 to 2005, where the Atlantic (Limon Bay) station recorded greater precipitation, and the Pacific (Balboa) station showed a drier climate (URS Holdings, Inc., 2007).

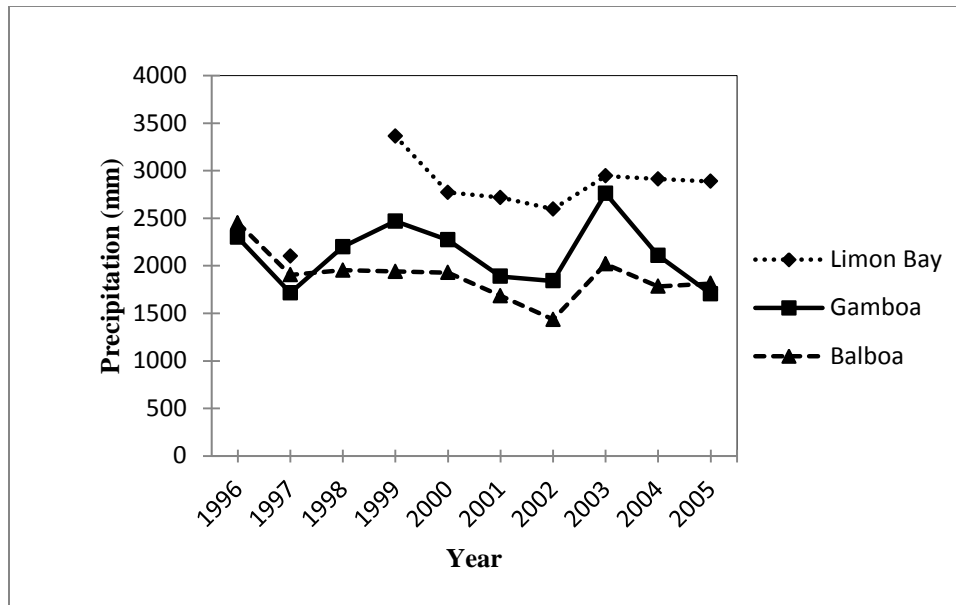

Figure 2 - Annual precipitation values at ACP rainfall stations near Panama Canal (URS Holdings, Inc., 2007)

2.3 Expansion of the Panama Canal

The Panama Canal Authority submitted a proposal in April of 2006 to expand the capacity of the canal by building a third set of locks. The plan was initiated in September of 2007 and has three components as shown in Figure 3:

- Construction of two Post-Panamax lock systems, one on the Atlantic side and the other on the Pacific side, each with three chambers and three water reutilization basins (areas 1 and 3 in Figure 3);
- Excavation of new access channels to the locks and the widening of the existing navigational channels; and
- Deepening of navigational channels and the elevation of Gatún Lake's maximum operating level.

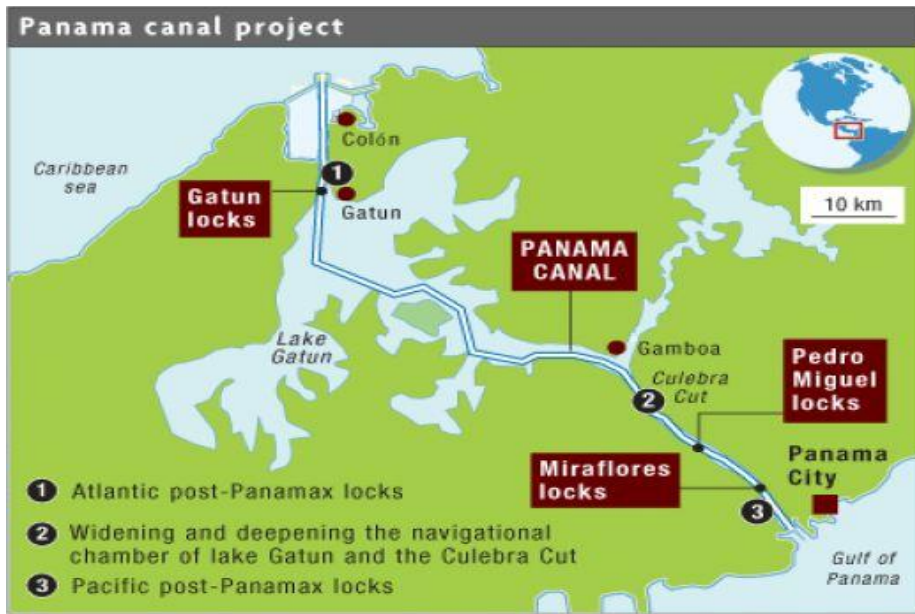

Figure 3 - Locations of the three components of the Panama Canal expansion program (Wright, 2006)

2.3.1 New Lock Systems and Retention Basins

The master plan of the Panama Canal Authority in 2006 was to upgrade its two lock lanes to three lock lanes. The Post-Panamax locks will consist of three lock chambers with each chamber serviced by three reutilization basins, thus nine basins per lock. A cross section of the new locks and their reutilization basins is shown in Figure 4. The same gravitational feed that is used in the original locks will be used to fill and empty the new locks.

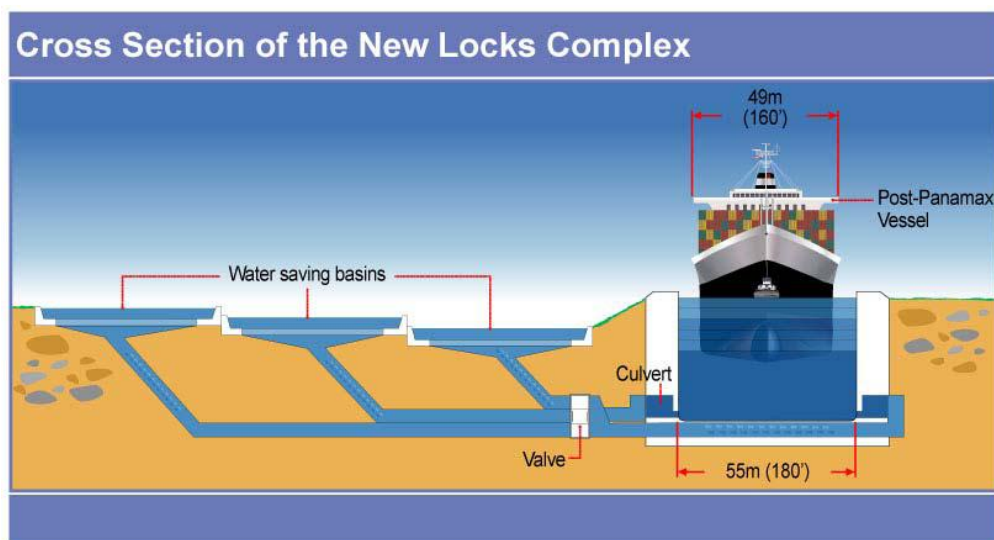

Figure 4 - Cross section of the new locks and their water reutilization basins (Panama Canal Authority, 2006)

The Panama Canal Authority (2006) notes that this is not the first attempt to construct a third set of locks. The U.S. started excavation in 1940 during their management of the canal. However, the project was suspended in 1942 when the U.S. entered World War II. The present effort will therefore build on the excavations that were done previously.

The new locks will be 427 m (1400 ft) long, 55 m (180 ft) wide and 18.3 m (60 ft) deep, in comparison to the previous locks with average dimensions of 320 m (1050 ft) long, 33.5 m (110ft) and 12.5 m (41ft) deep. These new locks will allow Post-Panamax vessels to cross the canal. Instead of using the miter gates that are used by the existing locks, the new locks will use rolling gates. Rolling gates are used in locks in Belgium, The Netherlands, and France. Tug boats will also be used instead of locomotives to position vessels.

2.3.2. Expansion of Navigational Channels

In order for the new set of locks to be incorporated into the existing network of channels, new channels are being excavated. The new Atlantic locks will be connected to the existing sea entrance by excavating a 3.2 km-long access channel. For the Pacific side, there will be two new access channels. The north access channel (6.2 km) will connect the Gaillard Cut to the new locks, circumventing Miraflores Lake. The south access channel will connect the new locks with the Pacific Ocean entrance and will be 1.8 km in length. The conceptual locations of the new Atlantic and Pacific Locks are shown in Figure 5.

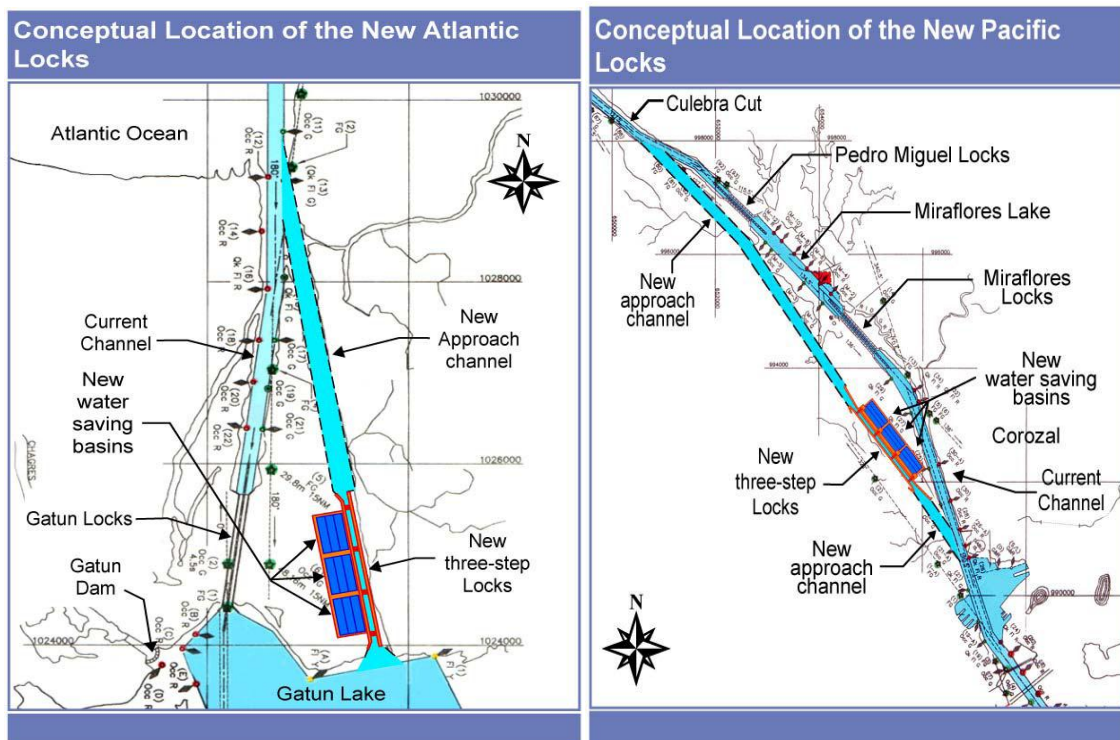

Figure 5 - Conceptual locations of the new Atlantic (left) and Pacific (right) locks (Panama Canal Authority, 2006)

The existing navigational channels are also being deepened and widened to accommodate Post-Panamax vessels. Channels within the Gaillard Cut and Gatún Lake will be deepened by up to 9.2 m (30 ft). The channels of Gatún Lake will also be widened to no less than 280 m (920 ft) in their straight sections and 366 m (1200 ft) in their turns, which will facilitate two-way traffic. The sea entrance navigation channels on the Pacific and Atlantic sides will be widened to no less than 225 m (740 ft) and deepened to 15.5 m (51 ft) below the level of the lowest tides (Panama Canal Authority, 2006).

2.4 Soil Erosion

The widening and deepening of the canal channel and the excavation of the new locks involve the relocation and storage of soil in other locations. The removal of vegetation cover leaves soil exposed and more susceptible to erosion. Erosion is a natural process in which soil and rock materials are detached or loosened from their original location and deposited elsewhere. The process predominantly occurs due to runoff from rainfall, which is prevalent in the Panama Canal area (Rickson, 2006; Meyer and Wischmeier, 1969; Jin and Englande Jr., 2009).

Accelerated erosion is an increase in the total suspended sediments being removed by runoff. This typically occurs when land is developed for agricultural or urban uses, or when deforestation takes place. Under these conditions, erosion rates are increased compared to land with natural vegetation. This is because there are limited root systems to hold the soil in place or canopy cover to protect the soil from raindrop splash impact and overland flow (Franklin, Hampden, Hampshire Conservation Districts, 2003). The following sections present information on accelerated erosion and the best management practices to reduce erosion.

2.4.1 Causes of Soil Erosion

The primary factors that influence the rate of erosion are climate, land use and geology. Climatic factors include the amount and intensity of precipitation, seasonality, wind speed and the typical temperature range. In general, areas with high-intensity precipitation, frequent rainfall or stronger winds experience higher rates of erosion. Higher temperatures also influence the weathering process, which is the breakdown of minerals in rocks chemically or physically. The weathering process increases with higher temperatures and consequently promotes higher erosion rates (Franklin, Hampden, Hampshire Conservation Districts, 2003).

The factor that has the most influence on the potential for erosion is land use, which affects the ground cover from vegetation and drainage. Humans play a significant role in excessive or accelerated soil erosion based on land use practices. When ground cover provided by natural vegetation is removed for agriculture, urban development, or mining, the soil structure is damaged. The effects of excessive vehicle traffic during construction, or modifications to slope gradients by excavation and embankments leads to a compacted or disturbed soil, changing the

natural drainage patterns. In urban areas, an increased percentage of impermeable surfaces results in large amounts of water moving quickly across a site, which can carry more sediment and other pollutants to streams and rivers (Jin and Englande Jr, 2009; Rickson, 2006). Erosion rates from construction sites range from 7.2 to over 1,000 tons/acre/year, while natural areas such as undisturbed forested lands that are typically less than 1 ton/acre/year (Jin & Englande Jr, 2009).

Geologic factors include the rock type, soil porosity, permeability and the slope (gradient) of the land. For example, the more fine-grained material there is in the soil, the greater amount of the material that will be picked up by water as it flows across the surface. Also the steeper the slope, the faster the water will move over the surface, thus being able to dislodge more soil. Typically, larger unprotected land areas have greater potential for erosion. Soil porosity and permeability affect the speed with which the water percolates into the ground. The more water percolates through the soil, the less runoff is generated, thus the rate of surface erosion is reduced (Franklin, Hampden, Hampshire Conservation Districts, 2003).

Soil erosion is also caused by the force of wind. Open gravel pits and construction sites that have been stripped of vegetation are especially vulnerable to wind erosion. The wind-borne sediments land in streams, roads, and neighboring lots. Blowing dust is a nuisance, and can be a hazard on especially windy days. Wind erosion in areas undergoing development can be controlled by keeping disturbed areas small and by stabilizing and protecting them as soon as possible (Franklin, Hampden, Hampshire Conservation Districts, 2003).

2.4.2 Erosion Control Practices

The aim of soil erosion control practices is to reduce accelerated rates of soil erosion and restore the balance between soil loss and formation rates. Erosion control practices, also called best management practices (BMPs), are methods, measures or practices used to mitigate nonpoint source pollution. BMPs for soil erosion include, but are not limited to, structural and non-structural controls and operations and maintenance procedures (Novotny, 2003). The structural controls include gabions, riprap, culverts, silt fences and sedimentation basins. Non-structural controls include hydroseeding, geotextiles and mulch and netting. Among these controls, some are temporary erosion control methods used during construction (silt fences and sedimentation basins). Others are permanent measures implemented after construction (riprap, gabions and hydroseeding).

2.4.2.1 Temporary Erosion Control Practices

Silt fences and sediment traps are temporary structures installed at the periphery of a disturbed area or on a channel having a small sediment-laden flow, such as the drainage channels from construction or mining sites. Their purpose is to reduce the velocity of sheet flow run-off and provide filtration. Settling occurs when there is a reduction of the velocity of the incoming flow

which results in ponding of the water, as illustrated in Figure 6. As the water percolates through the silt fence fabric, much of the suspended sediment is filtered out. Silt fences and sediment traps are most effective when combined with other erosion controls, but they are suitable for applications at the bottom of exposed and erodible slopes, above hydroseeding, along stream and channel banks, around temporary spoil areas and stockpiles, and in ditches. They may be made of many different materials, of which straw bales and filter fabric are most common. The filter fabric is usually entrenched, attached to supporting poles and backed by a plastic or wire mesh for support (California Stormwater Quality Association, 2003; Novotny, 2003).



Figure 6 - A properly installed silt fence retaining run-off for sedimentation and filtration to occur (Carpenter, 2006)

Temporary erosion control measures have limitations. First, the BMPs are not effective in streams, channels, drain inlets or anywhere flow is concentrated, because ponding of the water before filtration may lead to flooding on the upstream side of the fence. Flooding may cause undercutting, overlapping or collapsing of the fence. Figure 7 shows the overlapping and collapsing of a silt fence due to flooding that occurs when installed along a concentrated flow. In order to prevent flooding, installation of silt fences needs to follow standards that include trenching (excavation of a ditch to make sure silt fence is below the surface of the soil) and keying (bottom of silt fence should be a minimum of 150 mm (12 inches) into the ground). Also, their use is restricted to slopes of no greater than 4:1 (base:height). Lastly, the water depth must not exceed 1.5 ft at any point during ponding. For these reasons, silt fences are not a permanent solution but rather a temporary practice used for controlling erosion (California Stormwater Quality Association, 2003).



Figure 7 - Overlapping and collapse of a silt fence due to flooding when installed at a concentrated flow (Carpenter, 2006)

Silt fences and sediment traps require inspection every seven days and within 24 hours of a rainfall event of 10 mm (5 inches) or more. Maintenance includes the repair of fences that have been undercut, replacement of split, torn or weathered fabric, and the removal of trapped sediment when it reaches one-third of the barrier height. The average annual cost for installation and maintenance is \$25 per meter (\$7 per lineal foot) if a useful life of 6 months is assumed (California Stormwater Quality Association, 2003; NDDoH, 2001).

2.4.2.2 Permanent Erosion Control Practices

Hydroseeding or hydromulching involves applying a combination of grass seed, fertilizer, hydromulch and water in one liquified state to the soil surface. It is proposed by the North Dakota Department of Health (2001) to be the most efficient and cost-effective permanent BMP due to its one time application and low maintenance. The installation cost varies from \$0.75 – \$1.94 per square meter (\$0.07 - \$0.18 per square foot), which is less than a quarter of the cost of using sod. The germination of the seeds depends on the weather, time of year, amount of water and other factors, but generally the grass grows in 5-7 days. Hydroseeding works well because the seed is suspended in a nutrient rich slurry that promotes faster germination than ordinary seeding. The mulch layer seals in the moisture, holds the soil in place and promotes the greenhouse effect. Seeding should be initiated within seven days after grading activities have temporarily or permanently ceased on a portion of the project site. The drawbacks with hydroseeding are that it may be inappropriate in dry periods without additional irrigation (Earth Groomers, n.d.; NDDoH, 2001).

Another permanent erosion control method is the use of riprap. Riprap consists of heavy stones placed at the inlets and outlets of pipes or paved channels to provide protection against soil

erosion. Riprap is used in areas of concentrated flow, turbulence or wave energy as shown in Figure 8. The effectiveness of the riprap depends on the mass and size of the materials that are used. The gaps between the rocks trap and slow the flow of water, reducing its ability cause erosion. A well-graded mixture of rocks is recommended, with predominantly larger stones and sufficient smaller sizes to fill the voids. Channel riprap applies where design flow velocity exceeds 1.21 m/sec (4 ft/sec) and conditions are unsuitable for grass-lined channels (Metropolitan Council/Barr Engineering Co., 2001).



Figure 8 - Stream bank showing the use of riprap for erosion control (Michigan Department of Water Resources, 2011)

Gabions are rectangular baskets fabricated from a hexagonal mesh of heavily galvanized steel wire. The baskets are filled with rock and stacked atop one another to form a wall, as shown in Figure 9. They depend mainly on the interlocking of the individual stones and rocks within the wire mesh for internal stability, and their mass or weight to resist hydraulic and earth forces. They are a porous type of structure that can sometimes be vegetated. Gabions are considered to be compact structural solutions that have minimal habitat and aesthetic value (Franklin, Hampden, Hampshire Conservation Districts, 2003).

Gabions are used to slow the velocity of concentrated runoff or to stabilize slopes with seepage problems and/or non-cohesive soils. They can be used at soil-water interfaces, where the soil conditions, water turbulence, water velocity, and expected vegetative cover are such that the soil may erode under the design flow conditions. Gabions can be used on steeper slopes than riprap and are sometimes the only feasible option for stabilizing an area where there is not enough room to accommodate a vegetated solution (Franklin, Hampden, Hampshire Conservation Districts, 2003).



Figure 9 - Stabilization of slope area using gabions (South Fayette Conservation Group, 2008)

2.4.3 Measuring Soil Loss

Several methods can be used to monitor and assess erosion. These methods include visual indicators, watershed cover indicators, remote sensing of land cover, silt fencing catchments, erosion bridges, erosion plots, close range photogrammetry and cesium-137. The first three are classified as indirect indicators of erosion, while the latter five are direct measurement procedures (Ypsilantis, 2011).

Visual indicators of erosion involve the use of certain visual signs, such as pedestals, rills, litter movement, flow patterns, deposition and gully patterns. Using visual indicators provides a qualitative assessment of erosion and many observations can be made during a field visit. The major disadvantage with using visual indicators is that the method is subjective and there may be variations in observer ratings. Assessing watershed cover is also a visual indicator of erosion as the changes in cover can be accurately monitored qualitatively or quantitatively by using the canopy gap intercept method. The gap intercept method provides an indication of how much plant cover has aggregated or dispersed. The watershed cover method is relatively simple to perform and a good qualitative assessment of erosion but it also provides quantitative, repeatable data that can be done simultaneously with trend monitoring. However, estimated cover can vary between observers. Remote sensing of land cover is the last method of indirect indicators and involves the use of aerial photography to estimate changes in canopy cover over time. This method allows for extensive, unbiased and economical sampling and monitoring of canopy cover. The data collected using this method are presented in spatial relationships and spectral reflectance properties rather than direct measurements of an indicator (Ypsilantis, 2011)

The silt fence catchment method involves the use of silt fences to collect eroded sediments. The silt fences are cleaned periodically and the volume of the sediment trapped behind the silt fence measured and recorded at different intervals after rainfall events. This method is relatively economical and can be installed by small field crews. However, silt fences may be overtopped by runoff and sediments and if not properly installed, undercutting may occur. It is time consuming to collect and measure sediments trapped and the contributing area must be accurately measured. The volume of the sediments collected is divided by the contributing area to obtain an erosion rate for the time period between cleanouts (Ypsilantis, 2011).

The erosion bridge is a portable device consisting of a rigid level mounted on fixed stakes. Taking a measurement using a soil erosion bridge consists of placing a rod vertically through previously machined holes in a masonry level such that the rod touches the ground surface. Measurements are taken from the top of the level to the top of the rod with a measuring ruler (Jin and Englande Jr., 2009). The rod is adjusted to touch the soil at future sampling events, and changes in rod height indicate soil deposition or erosion. The advantage of the erosion bridge is that it is an inexpensive, rapid and unbiased method for monitoring erosion. However, the disadvantage is that the rebar can move if disturbed by humans, vehicular traffic or animals, which causes errors in the measurements.

Erosion plots provide an accurate monitoring method for measuring erosion. These artificial plots are usually made 50 feet long and 10 feet wide, with collection tanks and cumulative mechanical stage-height counters. The collection tanks are placed at the bottom of the slope and record runoff after each rain event. The mechanical stage-height counters are fixed across a section of the plot and record the changes in soil height over time. The plots can be replicated to provide control areas for comparison. The advantages of this method are that long term runoff and erosion rates can be measured and the Universal Soil Loss Equation can be applied. The disadvantages are that the equipment failures can damage plots and there is difficulty in finding duplicate conditions for the erosion plots out in the field (Ypsilantis, 2011).

The most expensive of the direct measurement techniques are close-range photogrammetry and cesium-137 methods. Close-range photogrammetry is defined as having a distance less than 300 meters between camera and object. A camera is used to take a series of overlapping photographs of a subject area with circular reference targets. These images are then used in a computer program to design three dimensional models of the terrain. This method is effective for areas that have remained devoid of vegetation, such as roads and construction sites. Cesium-137 is an artificial radionuclide with a half-life of approximately 30 years. The fallout from atmospheric nuclear weapons testing in the mid-1950s through the mid-1960s caused the dispersion of this substance globally by deposition (mostly by rainfall). It was absorbed quickly upon reaching the soil surface and remains nonexchangeable. Water erosion is the dominant factor moving the cesium-137 which is attached to the soil particles. In order to monitor soil erosion, soil core samples are collected from a study area and an undisturbed area for comparison. This method is

suitable for long-term erosion monitoring but it is not suitable for relatively short-term monitoring of the effect of erosion controls on erosion rates (Ypsilantis, 2011).

2.4.3.1 Case Study: Erosion Bridge

A field study done on the cost-effectiveness of five erosion control measures evaluated soil loss or erosion quantities by using an erosion bridge. The five erosion control measures were wood chips, straw bedding, temporary seeding, Geojute netting and Curlex blankets. An erosion bridge was deemed the most appropriate evaluating method due to its adaptability to different soil types and statistical soundness, producing accurate and consistent results over time.

Taking a measurement using a soil erosion bridge consisted of placing a rod through previously machined holes in the level and measuring from the top of the level to the top of the rod with a measuring ruler as shown in Figure 10. The level has ten equally spaced holes drilled in the upper and lower flanges, thus ten measurements can be taken per bridge (Jin & Englande Jr, 2009).

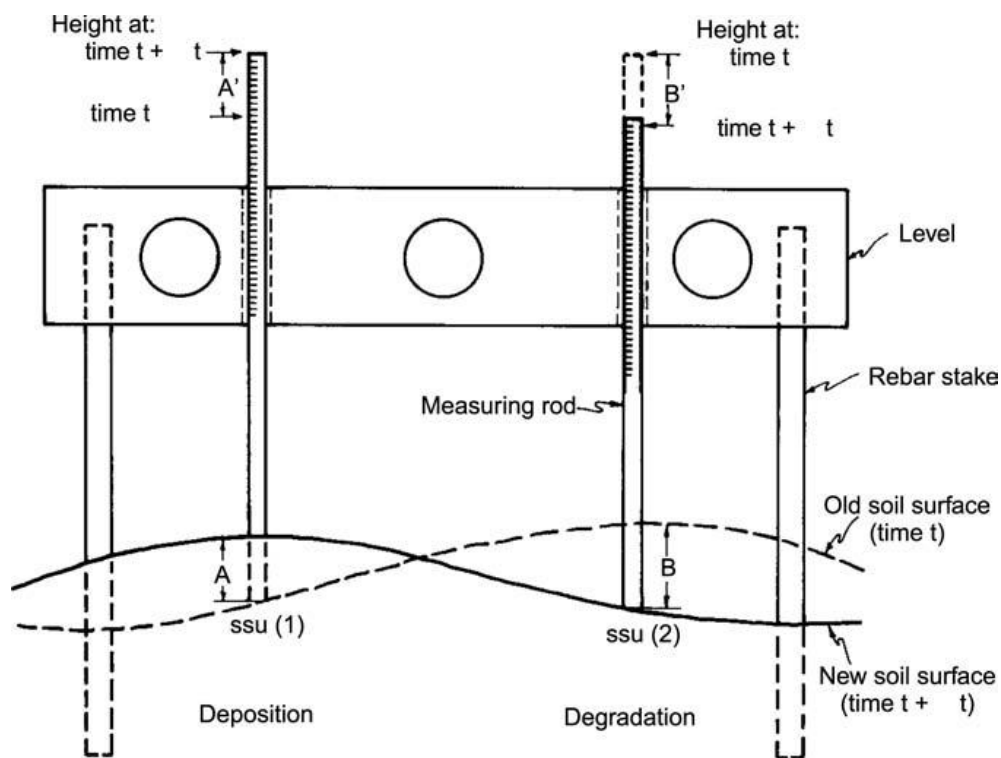

Figure 10 - Erosion control bridge (Blaney and Warrington, 1983)

Control plots were used to compare the effectiveness of the five erosion control measures for mitigating soil loss. The soil level change (Δd) for each plot was calculated to be the arithmetic mean of the difference of the readings at time one and time two for all sampling locations. The

soil level change (Δd) was then converted to soil loss (r) by Equation 1 (Blaney and Warrington, 1983):

$$r = 113.31 \times \rho \times \Delta d \quad \text{(Equation 1)}$$

where:

r = soil loss (tons per acre)

ρ = bulk density of soil (g/cm^3)

Δd = soil level change (inches)

To evaluate the soil erosion rate ($\text{tons acre}^{-1}\text{yr}^{-1}$) for each control measure, soil loss (r) was divided by sampling period (Δt) for each sampling period (two-to-three weeks). Then, the arithmetic mean of soil erosion rates for all sampling periods was calculated on a per year basis. Precipitation was measured using a sigma tipping bucket rain gauge. Then soils were classified in hydrologic groups: A, B, C, and D. Group A soils include sand and gravel, which have a low runoff potential and high infiltration rates. Group B soils are sandy loam soils with moderately fine to moderately coarse textures. Soils in group C have slow infiltration rates and these soils typically are silty-loam soils with moderately fine to fine texture. Group D soils have high surface runoff potential and very slow infiltration rates. These soils consist chiefly of clay soils with a high swelling potential, soils with a permanently high water table, soils with a clay pan or clay layer at or near the surface, and shallow soils over nearly impervious material (Jin and Englande Jr, 2009).

Data collection occurred over a period of eight months with a total of 45 inches of precipitation. Each erosion control measure was analyzed using a plot of soil loss against time. It was found that all five control measures were effective in reducing soil erosion, with similar results among wood chips, temporary seeding and straw bedding. These control measures reduced soil erosion rates by 75% to 85%. The Geojute fabric and Curlex blanket were better than the others, with 93 - 100% reduction in soil erosion rates. However, when cost was factored in, the most cost-effective measure was temporary seeding using perennial rye grass (Jin and Englande Jr., 2009).

2.4.4 Summary

Erosion control is one of the most important environmental aspects being addressed during the Panama Canal expansion project. The expansion project involves the excavation of land that leaves soil exposed to accelerated erosion rates. The increased transport of soil when rainfall occurs causes more soil deposits into the canal, which affects channel navigation and can cause damage to marine life. The contractors are responsible for implementing temporary and permanent erosion control measures during and after expansion activities. The effectiveness of these erosion control measures can be evaluated quantitatively by using visual indicators, watershed cover indicators, remote sensing of land cover, silt fencing catchments, erosion bridges, erosion plots, close range photogrammetry or cesium-137.

3.0 METHODOLOGY

The goals of this project were (1) to evaluate the soil erosion mitigation best management practices (BMPs) for temporary and permanent erosion control implemented in the Pacific sector of the Panama Canal expansion program and (2) recommend an alternative design for erosion control. To accomplish our goals, we completed the following objectives. First, we conducted site assessments to gather information on current conditions at sites in the Pacific sector where expansion efforts are underway. Then, we determined soil erosion rates using historical data and erosion bridge measurements. Lastly, we compared results for different sites and different BMPs to assess the advantages and disadvantages of each. This chapter provides the methods used to meet the project goals.

3.1 Site Assessments

We conducted site assessments in the Pacific sector of the Panama Canal expansion area to gather data on current erosion issues and mitigation strategies. These site assessments included three components: visual inspections, slope measurements and interviews with ACP contractors responsible for the areas studied.

3.1.1 Visual Inspections

We visited six sites in the Pacific sector of the Panama Canal expansion program. Four of these six sites had BMPs installed, while the other two had none. The GPS coordinates of each site were recorded using a Trimble Juno SD handheld GIS mapping device (Sunnyvale, CA, USA). The coordinates were used to locate each site on GIS maps of the expansion area. At each site, observations were made and photographs were taken of the erosion control BMPs installed, vegetation cover, evidence of erosion (rill formations) and soil composition.

3.1.2 Slope Measurements

Slope angles at each site were determined locally using a tape measure, masonry level and a length of rope (see Figure 11). First, two points were identified on the slope. The first point (A) was marked by a stake in an uphill location, placed vertically into the hillside. The second point (B) was marked by a stake in a downhill location. The intersection of a horizontal line from the uphill stake and a vertical line from the downhill stake (point C) created a 90 degree angle. A rope was extended from the uphill stake A to point C and a masonry level was used to ensure that the rope was level. The tape measure was then used to measure (1) the vertical height, H, from point B to C, and (2) the horizontal distance, D, from point A to point C. The slope was calculated by dividing H (rise) by D (run). The slope angle was determined by calculating an inverse tangent of the slope. To express the steepness of the slope as a percentage, the ratio of H/D was multiplied by 100.

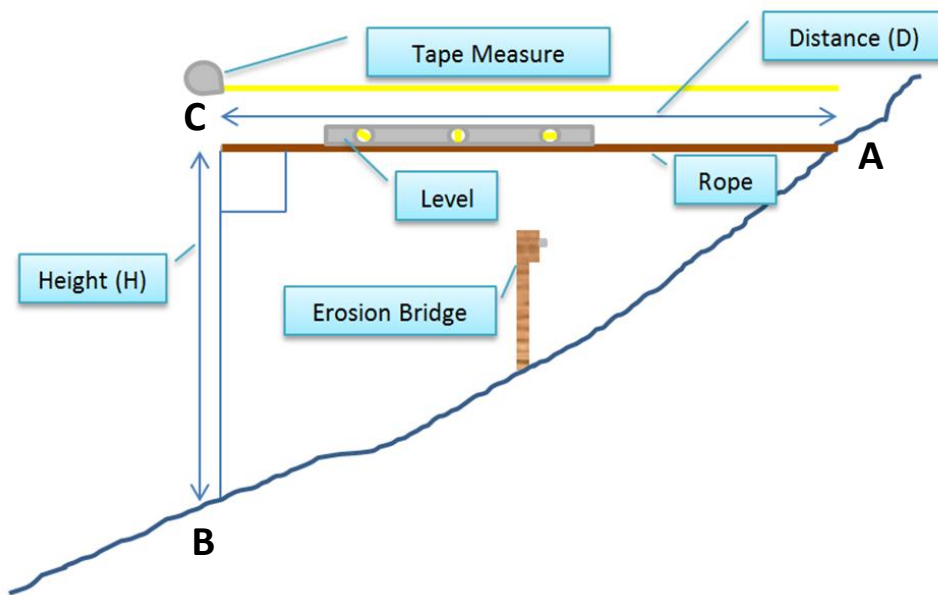

Figure 11 - Slope measurement schematic (side view) showing height, H and distance, D

3.1.3 Interviews with ACP Contractors

We interviewed a member of the environmental management department of Grupos Unidos por el Canal and a contractor from the fourth Pacific Access Channel (PAC 4) project. These contractors oversee the soil erosion mitigation measures in the canal expansion areas that we evaluated. We inquired as to the cost and maintenance schedules of the control practices installed and whether or not the measures installed were perceived to be applicable and/or adequate. The list of interview questions is shown in Appendix A.

3.2 Erosion Rates

The second objective was to determine soil erosion rates at the six Pacific sector sites. Erosion bridge measurements and stormwater runoff samples were used to obtain direct measures of erosion from each site. Historical data, including soil characteristics and rainfall amounts, were used to estimate yearly soil loss values. Each of these methods is described in the following sections.

3.2.1 Rainfall and Soil Data

Rainfall data were gathered from the ACP hydrometeorological station closest to our sites, which is located in Cocoli. Rainfall measurements were gathered for each day of the three weeks that measurements were taken for the soil erosion bridges (see section 4.2.3). Since rainfall is a factor that influences erosion, the rainfall data were plotted versus the soil erosion rates. From this plot, trends between soil loss and rainfall were observed.

The degree of soil saturation and the type of soil affect the rate of infiltration that occurs during a rainfall event. To determine soil types, the GPS coordinates of the sites were used to find the nearest geotechnical boreholes where soil cores were taken. Borehole information for each site was provided by the ACP Geotechnical Department. We also interviewed a member of the Geotechnical Department to obtain information on the soil classifications used in the Panama Canal area. The soil groups were collected from a GIS map that is shown in Appendix C. The system used is based on the USDA (1975) soil taxonomy, where classifications are based on the soil horizons present, drainage, texture, vegetation cover, originating material, slope erosion and its capacity for use. Soil data at the six sites were compared to runoff data (see section 4.2.2).

Bulk density of the soil at each site was measured by ACP laboratory personnel in compliance with ASTM D7263-09. Once the soil samples were brought to the laboratory, they were put into a 30 cm³ mold and then weighed. The weight of the mold was measured in order to calculate the weight of the wet soil. Then the sample was placed in an oven at 110°C for 24 hours. The dried samples were taken and weighed again and then weight of the dry soil was calculated. The dry density was calculated by dividing the dry weight by the volume of the sample that was in the mold.

3.2.2 Erosion Bridge Measurements

Quantitative historical erosion data were not available for any of the sites. The contractors only provided qualitative data on the effectiveness of the soil erosion control practices. Therefore, soil erosion bridges were used to obtain quantitative data on erosion at the sites. A total of six erosion bridges were installed, with one at each site. Four sites had BMPs (one with hydroseeding, one with silt fences, one with terracing, and one with both hydroseeding and silt fences), one had natural vegetation (control site) and one had clay soil. The bridges were located at sites that were selected based on accessibility and soil types that would allow for the installation of the bridge supports. In addition, our sponsors provided suggestions for areas that would not be disturbed in the time frame of our study.

The soil erosion bridge design was presented in section 2.4.3. The design was modified to use wooden planks for the saddle instead of masonry levels and pipe brackets were used instead of drilling holes into the blanks. A schematic of the constructed erosion bridge is shown in Figure 12. A level was used during installation to ensure that the bridge was level. A 4 foot steel rebar was used to obtain five sets of data from each bridge on seven different days. The soil level change (Δd) for each soil erosion bridge location was calculated to be the arithmetic mean of the difference of the readings at time one and time two for all sampling locations. The product of the soil level change (Δd) and the bulk density (ρ) of the soil at each site (see section 3.2.3) was then converted to soil loss (r) by Equation 1 (see section 2.4.3.1).

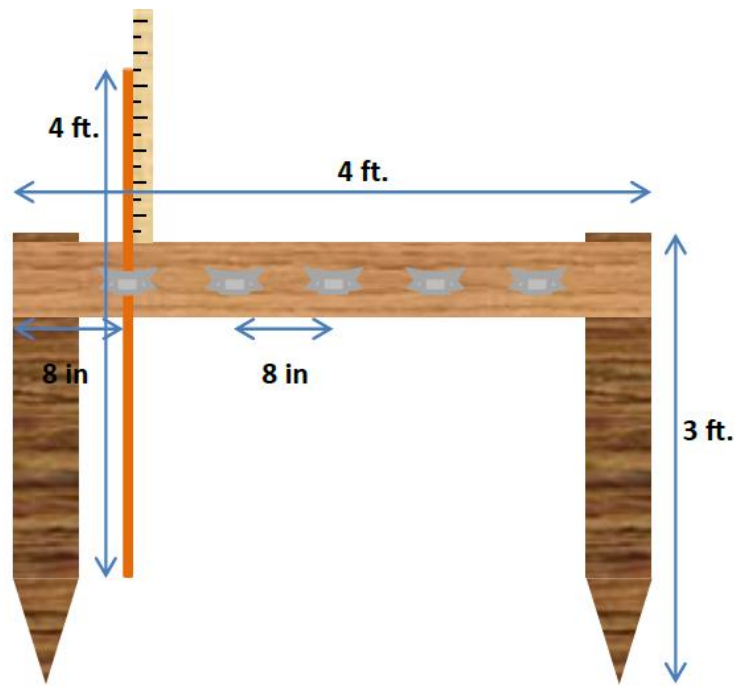

Figure 12 - Schematic of the constructed erosion bridge installed at each site

3.2.3 Storm Water Runoff Sampling

Storm water runoff samples were collected during one rain event at each of the six sites where soil erosion bridges were located. These samples were taken for comparison to the soil erosion rates calculated from the changes in soil level found using the erosion bridge. Accelerated erosion was defined in section 2.4 as the increase in the total suspended sediments being removed by runoff. Therefore, the greater the erosion rate, the greater the amount of total suspended solids found in the sample. The soil type was also considered when analyzing the results.

Clean 1 L Nalgene bottles were used to collect runoff samples during the first 15-30 minutes of the duration of the rain event as this is when the greatest load occurs (Marion et al., 2000). To collect a sample, the opening of the collection container was pointed upstream in the runoff flow so that the stormwater entered the bottle directly. The samples were analyzed for turbidity and total suspended solids.

Turbidity was measured in Nephelometric Turbidity Units (NTU) by the ACP laboratory personnel, according to Standard Method 2130-B (APHA et al., 2005). The sample was gently inverted to mix it, and then a sampling vial was filled and cleaned. The sample vial was placed in a turbidimeter (HACH 2100N, Loveland, Colorado, USA) and the turbidity value was recorded.

Total suspended solids (TSS) were measured by ACP laboratory personnel using Standard Method 2540-D (APHA et al., 2005). First, a glass fiber filter was washed, dried and weighed until a constant weight was achieved. The filter was placed in a filter holder and connected to a vacuum pump. A well-mixed sample was passed through the filter and the filter dried. The filter was then weighed and the total weight of solids left on the filter pad was recorded per volume of water.

3.2.4 Soil Loss Equation

The historical data provided by ACP, including soil characteristics and rainfall amounts, were used in the Revised Universal Soil Loss Equation (RUSLE) to estimate the yearly soil loss rate at each site. The results were compared to the direct measures of soil erosion using the soil erosion bridge. The RUSLE was used to calculate soil loss for each site location as seen in Equation 2:

$$A = R * K * L * S * C * P \quad \text{(Equation 2)}$$

where:

A = computed soil loss due to sheet, rill and gully erosion (tons/acre/year or metric tons/km²/year)

R = rainfall-runoff erosivity factor (hundreds of ft-tons-inch/acre-hour/year)

K = soil erodibility factor based on USDA soil types defined as the soil loss per unit of rainfall from a standard unit plot (tons-hour/hundreds of ft-tons-inch)

LS = length slope factor (unitless)

C = crop-management factor (unitless)

P = supporting practices factor (unitless)

First, each of the parameters in the RUSLE equation was calculated or determined. The R value or the rainfall energy was calculated using Equation 3. The R value was the same for each of the six observed measuring areas.

$$R = \frac{1}{n} \sum_{j=1}^n [\sum_{k=1}^m (E)(I_{30})_k] \quad \text{(Equation 3)}$$

where:

E = Total kinetic energy of a storm (foot tons/acre/inch of rain)

I₃₀ = Maximum 30 minute rainfall intensity (inches/hour)

n = Number of years observed

m = Number storms per year

j = Number of increments per year

k = Number of time increments per storm

To complete the R value calculations, the intensity of each rain storm was calculated. Rainfall measurements were provided by the ACP for the time period in which soil erosion bridge

measurements were conducted as mentioned in section 3.2.1. The measurements included (1) weekly total rainfall amounts and (2) length of time of each rainfall event on each day. The energy from the storm was calculated using Equation 4, where I is the rainfall intensity in units of inches per hour.

$$E = 1099[1 - 0.72 * \exp(-1.72 * I)], \frac{\text{foot tons}}{\text{acre}} \text{ per inch of rain} \quad (\text{Equation 4})$$

The K value or the soil erodibility factor depends on the percentage of sand and organic matter in the soil. Soil information was provided by the ACP from bore hole samples taken from locations nearby the six sites. Using this information, K values were determined using the figure presented in Appendix B which relates the percentages of sand, silt and organic matter along with soil structure and permeability to generate a representative value of a soil's ability to erode. Reference values were used to ensure that the calculated values were logical. The reference values were as follows: 0.05 – 0.15 for soils high in clay; 0.05 – 0.20 for soils that are high in sand; and 0.25 – 0.65 for soils high in organic matter (Jones, n.d.).

The LS or the Length Slope Factor accounts for the effect that topography has on erosion through the analysis of the steepness and length of the slope. Field measurements were completed to find slope angle (steepness) (see section 3.1.2). The other aspect of topography that this factor takes into account is the length that the slope extends for, also referred to as slope length. The slope length was measured using GPS coordinates to determine length of the slope between the bottom and top of the hill (distance between points A and B shown in Figure 13). GPS coordinates were recorded at the bottom and top of the hill. The length between these two points was determined by using the GPS distance calculator created by the Federal Communications Commission. The output was the distance between the two points calculated by the great circle method (Federal Communications Commission 1998). This was completed for each site where erosion bridges were located. The LS factor was then calculated using Equation 5 (Stone, 2000).

$$LS = [0.065 + 0.0456 * (\text{slope}) + 0.006541 * (\text{slope})^2] \times \left(\frac{\text{Slope Length}}{\text{Constant}} \right)^{NN} \quad (\text{Equation 5})$$

where:

slope = slope steepness (%)

slope length = length of slope (ft.)

constant = 72.5 Imperial or 22.1 metric

NN = Constant based upon steepness, in our case where all slopes are steeper than 5% the NN value is 0.5

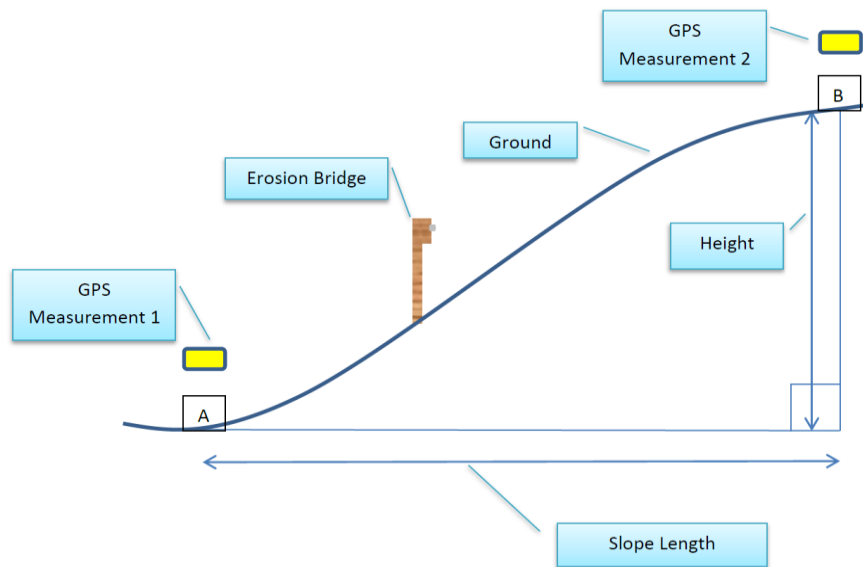

Figure 13 - Slope length measurement schematic (side view) showing GPS measuring points A and B

The C or the Crop Management Factor takes into account preventative soil covers such as grass, bushes, mulch or rock. We reviewed photographs taken of each site to estimate the percentage of ground cover and determine the type of surface cover material. A published table of values (see Table 1) was used to determine a C factor for each site. Rock cover, which is not shown on the Table, has a C factor of 0.02 (Pitt, 2004).

Table 1 - Vegetative C factor values (Pitt, 2004)

	Percent cover ¹	Plant type	Percentage of surface covered by residue in contact with the soil:					
			0 %	20	40	60	80	95+
C factor for grass, grasslike plants, or decaying compacted plant litter.	0	Grass	0.45	0.20	0.10	0.042	0.013	0.003
C factor for broadleaf herbaceous plants (including most weeds with little lateral root networks), or undecayed residues.	0	Weeds	0.45	0.24	0.15	0.091	0.043	0.011
Tall weeds or short brush with average drop height ² of ≥20 inches	25	Grass	0.36	0.17	0.09	0.038	0.013	0.003
		Weeds	0.36	0.20	0.13	0.083	0.041	0.011
	50	Grass	0.26	0.13	0.07	0.035	0.012	0.003
		Weeds	0.26	0.16	0.11	0.076	0.039	0.011
	75	Grass	0.17	0.10	0.06	0.032	0.011	0.003
		Weeds	0.17	0.12	0.09	0.068	0.038	0.011
Mechanically prepared sites, with no live vegetation and no topsoil, and no litter mixed in.	0	None	0.94	0.44	0.30	0.20	0.10	Not given

The P factor or the Supporting Practices Factor is not typically used in construction site evaluations as this factor takes into account tillage and crop rotation which does not occur in construction sites. Therefore this factor is given a value of 1 for construction zones (Pitt, 2004).

After the compilation of values for each site, the soil loss, A, was calculated. The A value represents the potential long term average annual soil loss in tons per acre per year. The calculated soil loss rate was then plotted against rainfall data to locate trends.

3.2.5 Blasting Data

The distance of sites 1-6 from the locations where blasting occurred was measured using the ArcGIS mapping program (ArcGIS version 10). This information was used to assess the effects that vibration from blasting activities have on the rate of soil erosion on the surrounding areas. For each location where blasting occurred, information was obtained from ACP on times and dates of blasting events, blasting duration, maximum instantaneous charge, radius affected and intensity of blast. The scaled distance and intensity were plotted against each other. This analysis was done in two parts where Sites 1 to 3 were related to blasting that occurred in PAC 0 and Sites 4 to 6 related to PAC 4 activities.

Vibrational level prediction formulas were used to calculate the peak particle velocity (PPV) or vibration intensity at each site using Equation 6.

$$PPV = K * SD^{-1.6} \quad \text{(Equation 6)}$$

where:

PPV = Peak particle velocity (m/s)

K = Ground transmission constant (K=160 if no other seismic data is available)

SD = Scaled distance factor (m/kg^{-1/2})

The scaled distance was calculated using the maximum instantaneous charge (amount of explosives used for blasting), W and the distance of the site from the blasting location, D shown in Equation 7.

$$SD = D/\sqrt{W} \quad \text{(Equation 7)}$$

where:

SD = Scaled distance factor (m/kg^{1/2})

W = Charge weight per delay (kg)

D = Distance (m)

3.3 BMP Evaluation

Best management practices can be used to mitigate soil loss. One of the objectives for this project was to compare the results for different sites and different BMPs to assess the advantages and disadvantages of each. Based on this analysis, recommendations were made for each of the project sites and for the Panama Canal expansion project in general. Criteria for evaluating the BMPs were determined based on background research and the conditions found at each site. The criteria were: short term effectiveness, applicability to different slope angles, applicability to different soil types, effectiveness without additional BMPs, estimated soil loss prevented, and

installation and maintenance costs. Each criterion was ranked on a scale from 1 to 3, where 1 = poor, 2 = neutral and 3 = good.

The criterion of short term effectiveness refers to how quickly the BMP becomes effective at controlling erosion in any area. The versatility of the BMP was assessed based on its applicability to different slope angles and soil types. Then, each BMP was ranked based on whether it can be applied alone. Each criterion was evaluated based on literature research, site assessments and erosion rate measurements. Historical data provided by the ACP were used to assess the installation and maintenance costs of each BMP. The estimated soil loss prevented was based on the erosion rates measured using soil erosion bridges, RUSLE equation estimates and previous research.

4.0 RESULTS AND ANALYSES

This chapter presents the data acquired from our site assessments, soil erosion bridge measurements and water quality testing. Information was also received from the ACP and its contractors on rainfall frequency, soil composition and blasting activities. These data were used to assess the factors that influence erosion, evaluate the effectiveness of the BMPs, and make recommendations for future BMP implementation.

4.1 Site Characteristics

Erosion data were collected using soil erosion bridges. Six sites were selected for the installation of these bridges. The bridges were located in areas that were selected based on accessibility and soil types that would allow for the installation of the bridge supports. In addition, our sponsors provided suggestions for areas that would not be disturbed in the time frame of our study. The soil erosion bridges provided a micro profile of the changes in the soils over time.

A soil erosion bridge was installed at each of the six sites, which included four sites that had best management practices (BMPs), one control area (natural vegetation) and one of clay soil type. Figure 14 is a GIS map of the expansion project areas designated as Pacific Access Channel 0 and 4 (PAC 0 and PAC 4). The sites with our soil erosion bridge are noted by the yellow dots.

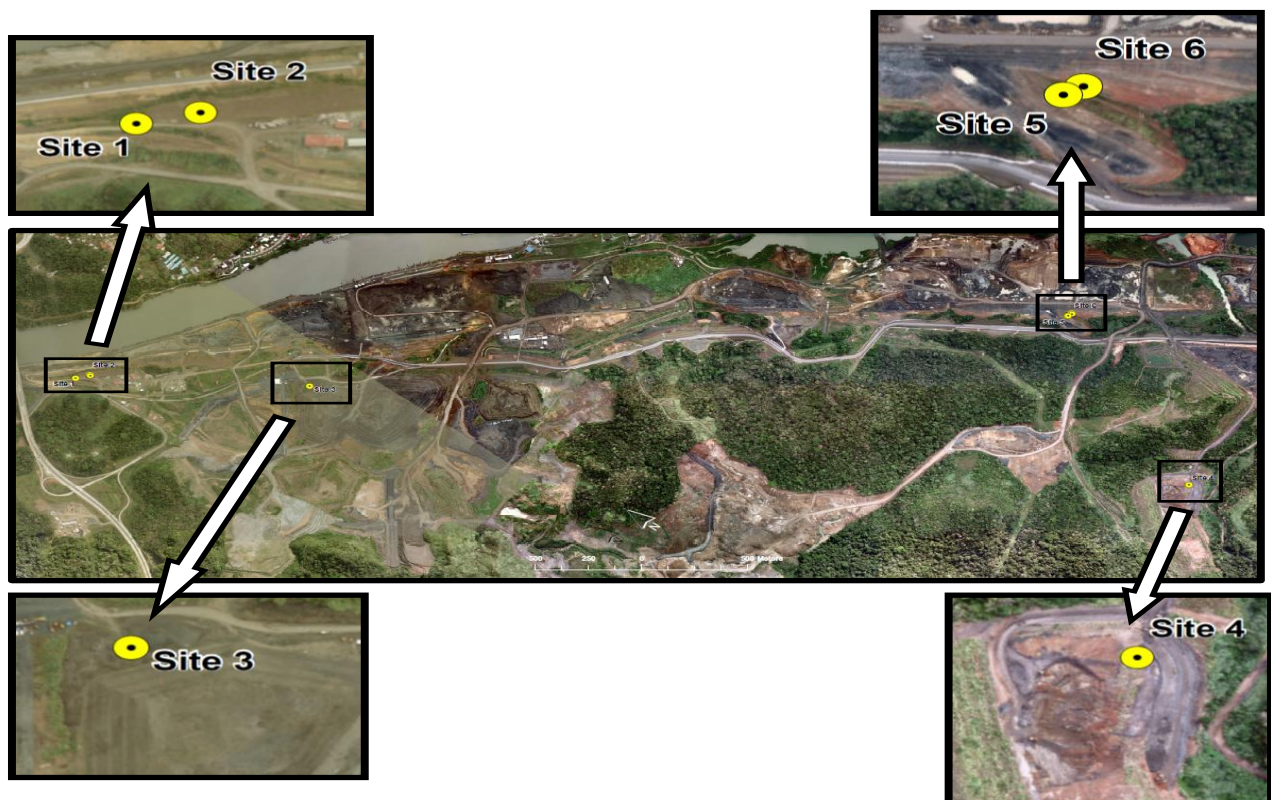

Figure 14 - GIS map showing locations of sites 1 to 6

4.1.1 Site 1 - Silt Fences

The first site that was evaluated was in the northern area of PAC 4 near the Centennial Bridge in Corozal parallel to Borinquen Road. This site was originally chosen as our control due to its lack of erosion control and steep slope, shown in Figure 15. However, after installation of the soil erosion bridge, the contractor responsible for the site installed silt fences upon the second day of measurement and further planned to implement hydroseeding within the following fifteen days. The hydroseeding of the area did not occur during our project. We were informed during our interview with a member of the environmental management department of Grupos Unidos por el Canal that the installation of silt fences is the first reaction to erosion. Figure 16 shows the site on our second visit to collect data after the silt fences had been installed. This provided us with a unique opportunity to measure erosion control methods before and after implementation, albeit for a short time period. The calculated slope for Site 1 was 56.6% or 29.5 degrees (calculations shown in Appendix D), which was steeper than any of the other site slopes. The soil cores obtained from the ACP showed that the soil in this area was a mix of clay, silt, sand, pebbles and boulders and is associated with the Cucaracha formation discussed in section 2.2.2 of the background chapter.



**Figure 15 - Site 1 with steep slope and no BMP at the time of erosion bridge installation
(Photo Credit: Tomás Antonio Edghill, 2011)**



Figure 16 - Site 1 showing silt fences installed after soil erosion bridge (Photo Credit: Bryan Lee, 2011)

4.1.2 Site 2 – Hydroseeding

The second site was located near the first site, on the other side of the hill overlooking the canal channel. This area is used by the ACP surveying department to take measurements of the channel. The erosion control method implemented at this site was hydroseeding, which was implemented in October of 2009. The slope at this site was calculated to be 30.8% or 17.1 degrees (see Appendix D), and there is a construction roadway located at the bottom of the slope. Although the hydroseeding provides vegetation cover that reduces erosion rates due to the root systems holding the soil in place, there were noticeable rill formations. ACP core samples of this site showed a soil structure of the Pedro Miguel formation (section 2.2.2), where pebbles, cobbles and rocks (up to 90 mm in diameter) are mixed with clay, silt and sand. The underlying layer is the Cucaracha formation (section 2.2.2). Figure 17 shows the installed soil erosion bridge at site 2.



Figure 17 - Soil erosion bridge installed at site 2 which features hydroseeding (Photo Credit: Bryan Lee, 2011)

4.1.3 Site 3 – Terracing

Site 3 was located approximately 1.2 km south of the first two sites near a contractor's workshop. During this project, site 3 was used as a deposit area for basalt. Basalt rocks from the Pacific side are used to make cement for canal construction. Terracing at this site was used to mitigate erosion. The large size and density of the basalt rocks promotes high infiltration rates and low runoff potential, which helps reduce soil loss from the area. The slope at this site was calculated to be 43.4% or 23.5 degrees (see Appendix D). No further BMPs were installed at this site as it was deemed unnecessary due to the temporary use of the area. Although this rocky soil does not foster a healthy environment for plant growth, there were some plants found in the area called Saccharin spontaneous (paja blanca) or white straw. Figure 18 shows the soil erosion bridge installed at Site 3, with evidence of scattered plant growth.



Figure 18 - Soil erosion bridge installed at site 3, with basalt rocks and scattered plant growth (Photo Credit: Bryan Lee, 2011)

4.1.4 Site 4 – Disposal Site/No BMP

This site was located in the southeastern area of PAC 4 and was also referred to as disposal site number twelve by the contractor from the fourth Pacific Access Channel (PAC 4) project. The material found at this site will not be further used in the locks project and the area is in need of landscaping to control erosion. Approximately 30% of the total area at this site was covered by natural vegetation. Deep rills and gullies were evident where vegetation cover was minimal. An ACP core sample of the soil in this area found the composition to be medium soft to medium hard clay, mixed with sand, basalt pebbles and boulders. The slope of this area was calculated to be 52.9% or 27.9 degrees (see Appendix D). Figure 19 shows the soil erosion bridge installed at site 4.



Figure 19 - Soil erosion bridge installed at site 4 with natural vegetation (Photo Credit: Bryan Lee, 2011)

4.1.5 Site 5 – Hydroseeding and Silt Fences

Site 5 was located in the eastern area of the expansion associated with PAC 4. Hydroseeding and silt fences were installed in August of 2011 by a previous contractor responsible for the area. The grass at this site had grown to a significant height, as shown in Figure 20. Although the grass was well established, there were signs of rill erosion in areas where ground cover was minimal. The slope was calculated to be 29.4% or 16.4 degrees (see Appendix D). The overburden at this site had clay soil and that was mixed with basalt pebbles (up to 3 inches in diameter), according to the ACP core sample.



Figure 20 - Location of soil erosion bridge at site 5 showing hydroseeding (Photo Credit: Bryan Lee, 2011)

4.1.6 Site 6 – Clay Soil Area

Site 6 was on the opposite side of the hill from site 5. This area was chosen due to its soil type. As shown in Figure 21, the site had clay as well as basalt pebbles and rocks of up to 3 inches in diameter. Soil erosion was present as demonstrated by rill formations and the outline of the drainage pattern over the area. The slope in the area was calculated to be 28.1% or 15.7 degrees (see Appendix D).



Figure 21 - Soil erosion bridge located at site 6 showing clay, basalt pebbles and rill erosion (Photo Credit: Bryan Lee, 2011)

4.2 Soil Erosion Rate

Erosion data were collected at the six sites by visual inspection, monitoring of soil erosion bridges and measurement of solids in runoff. The soil erosion bridges provided the change in the micro profile of each site over time, which were extrapolated to yearly erosion rates, and the runoff analysis provided data on the soil loss occurring at each site. Historical and site data, including rainfall and soil characteristics were then applied to the Revised Universal Soil Loss Equation (RUSLE) to estimate the yearly soil loss occurring at each site and provide a comparison of erosion rates at each site. Lastly, the data were compared to the factors that affect erosion, including rainfall intensity, soil type, slope (steepness), vegetation cover, time elapsed since installation of BMP and distance from blasting activities.

4.2.1 Soil Erosion Bridge Micro Profiles

Soil erosion bridges were used to track changes in the micro profiles of each site. Each bridge had five measuring rods, and data were collected on six occasions over a period of eighteen days. Changes at each site are discussed below.

4.2.1.1 Change in Micro Profiles for Site 1

The change in micro profiles for site 1 (silt fence BMP) is shown in Figure 22. This figure illustrates the change in the cross section of the slope below the soil erosion bridge over time. There is evidence that soil eroded between the initial measurement and the subsequent sampling days. The decline in height measured at hole 4 from day 0 to day 4 indicates that a rill may have formed at this location. However, there was also evidence of deposition between days 4 and 15 at hole 4, as the height increased from 17.8 in. to 18.8 in. A similar trend occurred at hole 1, where there was a decline in height from day 4 to 11, and deposition from day 11 to 15. The other three holes showed overall decreases in soil height.

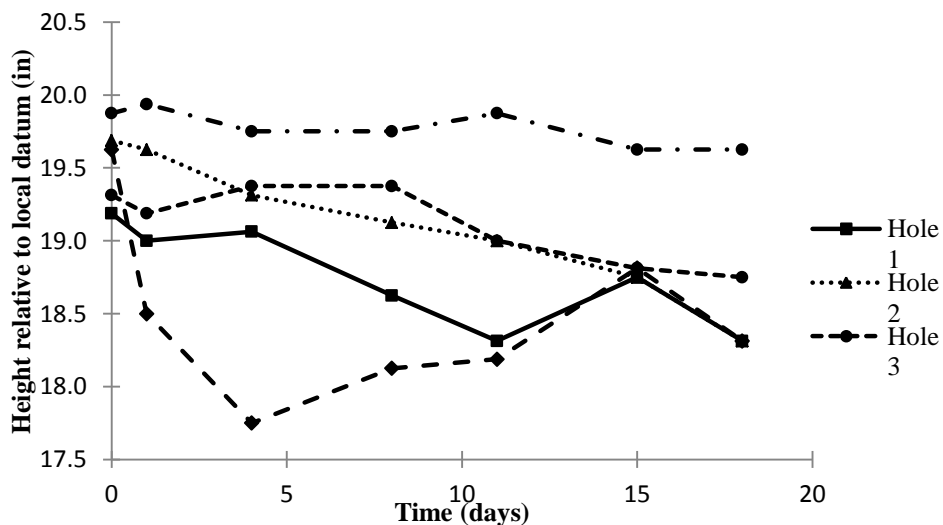

Figure 22 - Change in micro profiles for Site 1

The overall average reduction in soil depth considering all 5 holes at this site was 0.9 inches (22.4 millimeters). According to Ypsilantis (2011), a 1 millimeter (0.04 inches) reduction in soil depth represents about 5 tons per acre soil loss. Using this ratio and the average soil loss over the 18 days of measurement for this site, the yearly soil loss rate estimate is 2,300 tons per acre per year. This value exceeds the range for construction site erosion values, which is from 7.2 to over 1,000 tons per acre per year (Jin & Englande Jr, 2009). The large change at this site may be due to multiple factors, including the movement of larger material such as rocks which were part of the soil composition at this site and the steepness of the slope that was calculated to be 56.6% or 29.5 degrees. Also, the estimate was based on 18 days of data collection. Longer monitoring is recommended to improve the estimate.

4.2.1.2 Change in Micro Profiles for Site 2

Figure 23 shows the change in micro profiles for site 2 (hydroseeding BMP). Holes 1, 3 and 4 did not have significant changes in height over the 18 days of measurement. There was a decline in height between day 0 and day 4 for hole 2, which indicates that rill erosion may have occurred during that time. Hole 2 also had a deposition occur between day 4 and day 8 but this was only a small change of 0.1 inches. Hole 5 had an increase in height of 0.2 inches between day 4 and day 8 and then a similar decline between day 8 and day 11. Hole 5 however had a significant decline between day 15 and day 18, which may indicate rill erosion. The overall average reduction in soil depth at this site was 0.3 inches (7.3 mm), which is equivalent to approximately 36 tons per acre soil loss over 18 days. Per year, this represents a soil erosion rate of 730 tons per acre per year, which is comparable to the soil loss rate of construction sites but significantly less than the rate for Sites 1 and 4.

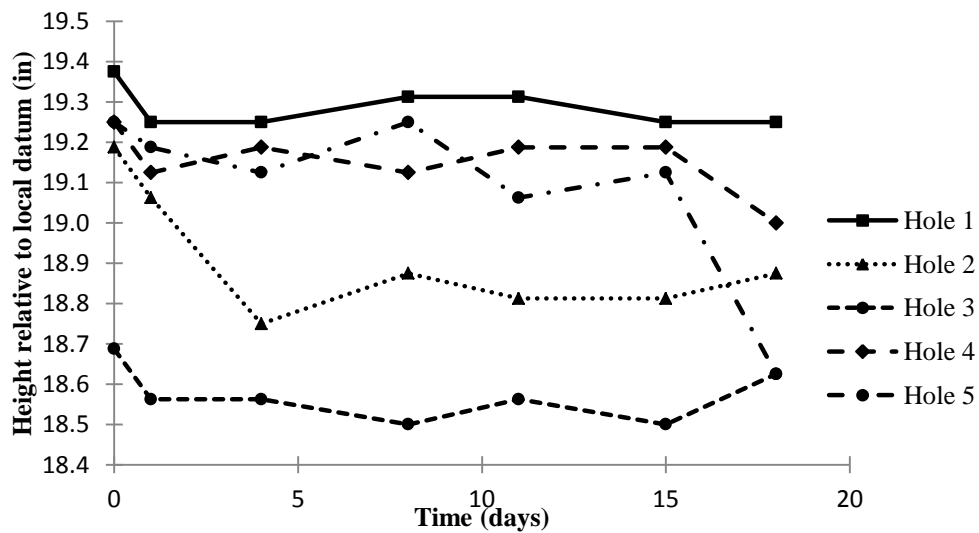

Figure 23 - Change in micro profiles for Site 2

4.2.1.3 Change in Micro Profiles for Site 3

The change in micro profiles for site 3 (terracing BMP) is shown in Figure 24. Hole 1 had no significant changes in height over the 18 days, with only 0.1 inch change between any two sampling days. Hole 2 had a decline in height of 1.0 inch between day 0 and day 4, followed by a 0.3 inch increase from day 4 to day 8, then a 0.6 inch decrease between day 8 and day 18. This area had significant changes over time with erosion and deposition occurring in succession. Holes 3 and 4 had similar trends where soil height declined between day 0 and day 4 and deposition occurred between day 4 and 8. This indicates that there may have been rill formations at these two holes. Hole 5 also showed both increases and decreases in soil height. The overall average reduction in soil depth at Site 3 was 0.5 inches (11.8 mm). The estimated soil loss according to the change in soil depth would be 60 tons per acre over 18 days, which would result in a rate of 1,200 tons per acre per year. The erosion rate at this site is therefore comparable to that of a construction site.

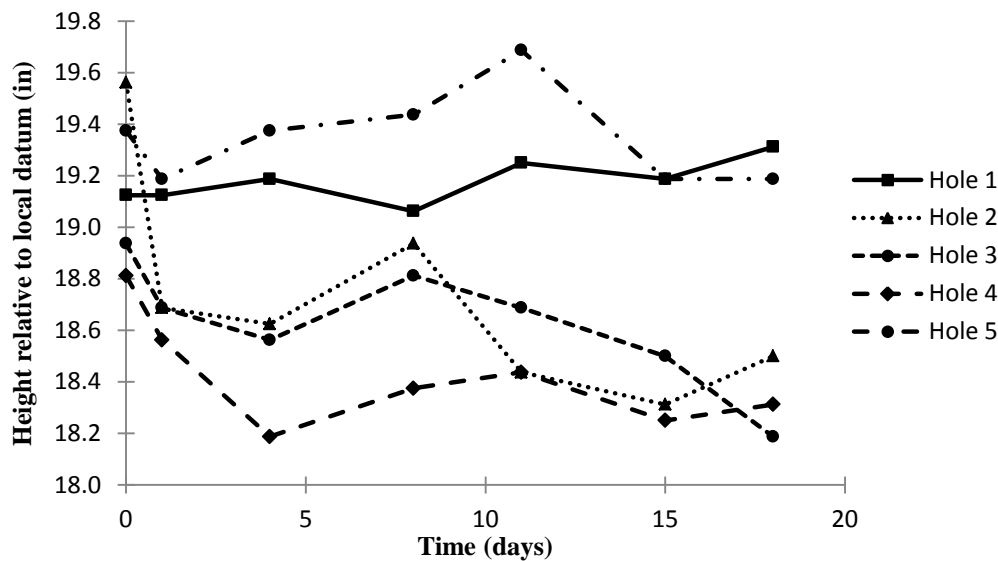

Figure 24 - Change in micro profiles for Site 3

4.2.1.4 Change in Micro Profiles for Site 4

Site 4 (no BMP) had many changes in its micro profiles over the duration of our recorded data, as shown in Figure 25. Hole 1 had increases in height between day 1 and day 4 and between day 8 and day 11. There was also a decline of 1.2 inches between day 11 and 18, which indicate that significant erosion may have occurred. Hole 2 had declines in soil height of 0.9 inches between day 0 and day 4 and 1.4 inches between day 8 and 15. The steep decline of 1.4 inches indicates that this area may have had a rill formation. Hole 3 had the most changes occur in its soil profile over the 18 days. A succession of erosion and deposition is indicated by the increases and decreases in soil height. The greatest change at hole 3 was a decline of 1.7 inches which indicated that there may have been a deep rill formed in this area. Holes 4 and 5 had similar

trends between day 4 and day 15, where there was an overall decline in soil height. Hole 4, however, had a sharp decline in soil height between day 0 and day 1 and then an increase between day 1 and day 4. This may have been due to rill formations. The overall average reduction in soil depth at this site was 1.1 inches (27.7 mm), which was the greatest among the sites. The estimated soil loss calculated from this change in depth was 138 tons per acre for the 18 days of testing, which equates to a rate of 2,800 tons per acre per year. This value exceeds the range for construction site erosion values.

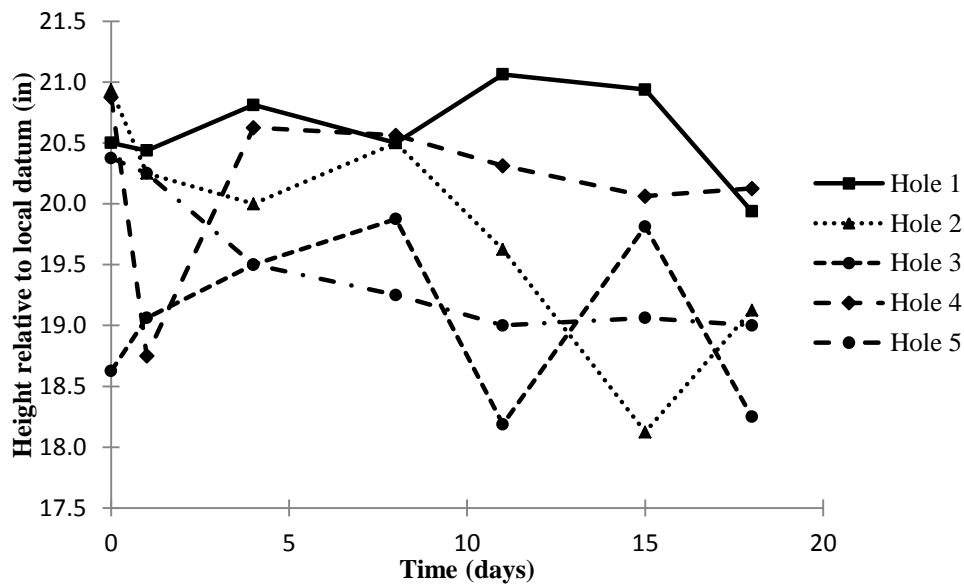

Figure 25 - Change in micro profiles for Site 4

4.2.1.5 Change in Micro Profiles for Site 5

The changes in the micro profiles for site 5 (hydroseeding and silt fences, Figure 26) showed a succession of erosion and deposition at the monitoring holes. Hole 1 had a range of 0 – 0.7 inch change in height between sampling days over the 18 days. Hole 2 had an overall reduction in soil height of 0.6 inch. The rise and decline in height between day 8 and 18 are similar for holes 2 and 5. Hole 4 had declines in height of 1.4 inches between day 0 and day 4 and 0.5 inches between day 11 and day 15. This large decline in height indicates that there may have been a deep rill formation. Hole 3 also had a significant decline in height between day 0 and day 8, which was followed by a rise in height between day 8 and 15. This indicated that another rill may have been formed. The overall average reduction in soil depth for this site was 0.5 inches (13.1 mm). The estimated soil loss according to the reduction in depth was calculated to be 65 tons per acre for 18 days, with a resulting erosion rate of 1,300 tons per acre per year. This estimate was similar to that found for site 3, which used terracing for erosion control.

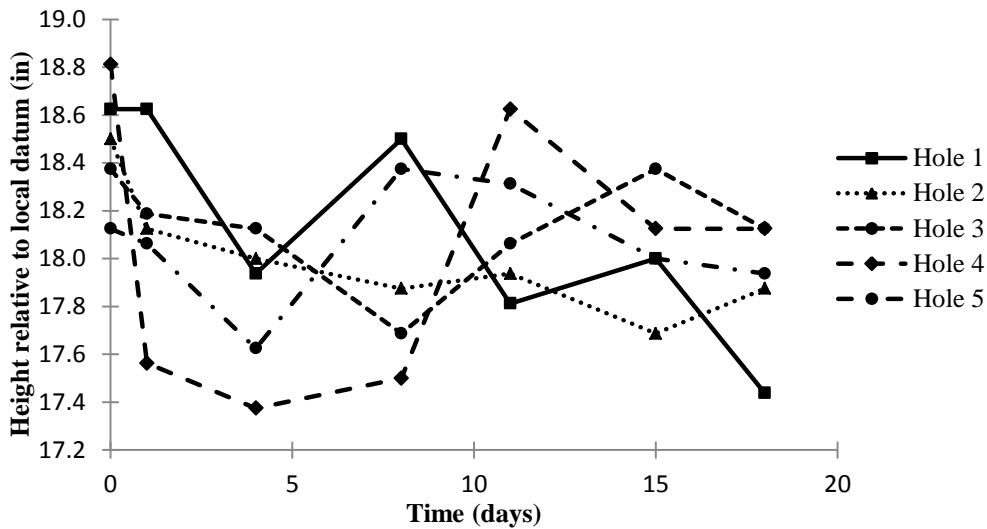

Figure 26 - Change in micro profiles for Site 5

4.2.1.6 Change in Micro Profiles for Site 6

This site had a soil composition of clay soil and basalt rocks. There were no major changes in its micro profiles over time (see Figure 27). Holes 2 and 5 had an overall increase in soil height over the 18 days. Hole 1 had a decline in height between day 1 and 4 but the following days had no significant changes in soil height. Holes 3 and 4 had the similar trend of overall reduction in height between day 0 and day 15. The overall average reduction in soil depth at this site was 0.1 inches (1.5 mm). The estimated soil loss according to the reduction in depth was calculated to be 8 tons per acre for 18 days, with a resulting erosion rate of 160 tons per acre per year. This was the smallest change recorded among the sites. This can be related to the slope of the area (28.1% or 15.7 degrees), which was also the least among the sites.

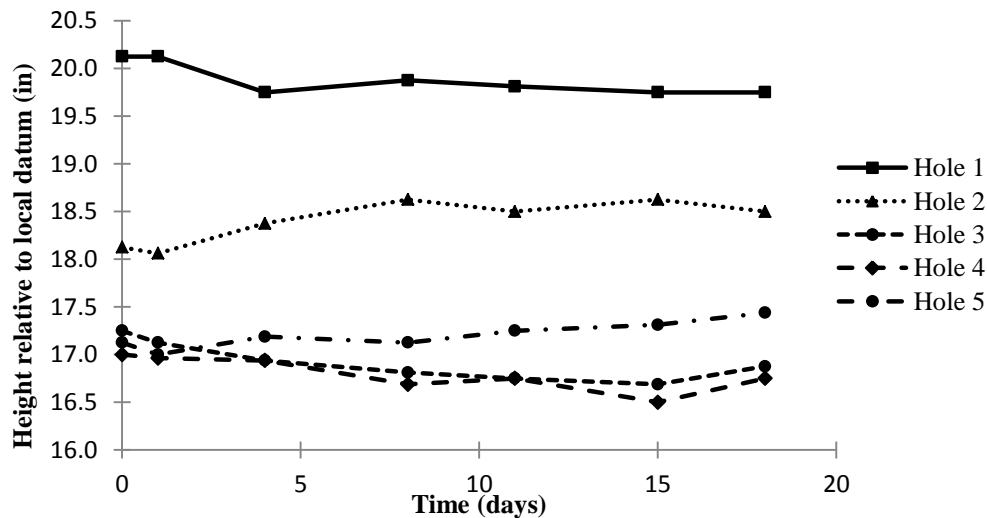

Figure 27 - Change in micro profiles for Site 6

4.2.2 Runoff Analysis

From interviews with the contractors of PAC 4, we found that one of their methods of assessing the effectiveness of the erosion controls was visual inspection of runoff from the site. This qualitative method focused on the clarity of the runoff. We measured turbidity and total suspended solids in runoff samples collected on November 29, 2011 at each of the six sites where erosion bridges were located. The samples were collected within 30 to 60 minutes after the start of the rainfall event that had an intensity of 1.75 mm/hr and a total rain accumulation of 42 mm.

The results are shown in Figure 28 (turbidity) and Figure 29 (TSS). Turbidity in runoff samples ranged from 18 to 1,856 ntu. Runoff from sites 2, 3, 4 and 5 had turbidity levels less than 60 ntu. The turbidity at site 1 (silt fencing) was 309 ntu, while the turbidity at site 6 (clay site) was significantly higher at 1,856 ntu. Suspended solids results showed similar trends, with runoff from sites 2, 3, 4 and 5 having levels less than 150 mg/L. Runoff from site 1 had the second highest level of suspended solids (263 mg/L), while runoff from site 6 had the highest at 855 mg/L.

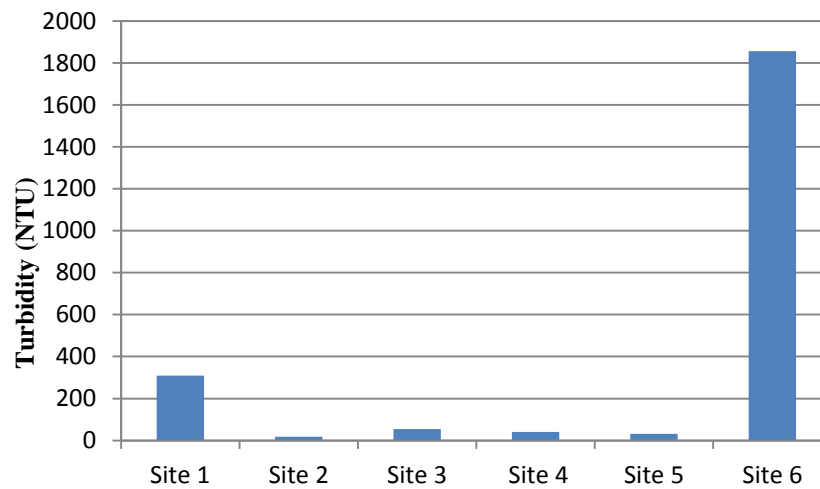

Figure 28 - Turbidity in runoff samples from each site collected during rain event of November 29, 2011

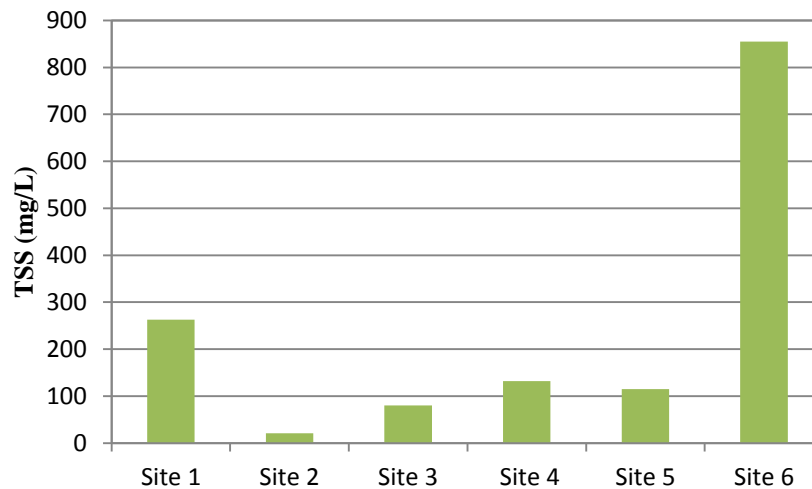

Figure 29 - Total suspended solids in runoff samples from each site collected during rain event of November 29, 2011

The difference in soil types among these sites may have affected the turbidity and solids concentrations in the runoff samples. Site 6 was composed of clay soil, which has smaller particle sizes than the other soil types such as silt and sand found at the other five sites. Soil particle size ranges include sand: 2.0 - 0.06 mm, silt: 0.06 - 0.002 mm, and clay: less than 0.002 mm (Pidwirny, 2006). Larger particles (sand) settle out over short transport distances, whereas small particles (clay) can be carried over long distances suspended in the water column causing turbidity (Lin, 2010). However, soil erosion bridge data showed that Site 6 had the least reduction in soil depth. This may have been due to the cohesiveness of clay as the particles bind together to create a greater surface area in relation to their diameter than larger particles. This tends to lower erodibility (NCSCC, 2006).

The presence of BMPs can also impact runoff characteristics. Site 2 had hydroseeding, which may have prevented sheet erosion during rainfall. The hydroseeding at this site had been in place since October of 2009, and our soil bridge results indicated that erosion rates were low at this site. Site 5 also had hydroseeding and silt fences installed, but these were only in place since August of 2011. Comparing sites 2 and 5, runoff from site 5 had higher turbidity (32 vs. 18 ntu) and higher suspended solids (115 vs 21 mg/L). These results indicate that there may be less vegetation cover and more shallow root systems at site 5.

The second largest turbidity and total suspended solids measurements were from site 1. This site had silt fences installed when the runoff sample was taken. Runoff characteristics may have been influenced by the slope angle at this site. The calculated slope for site 1 was 56.6% or 29.5 degrees which was the steepest among the sites. The steeper the slope, the faster the water will move over the surface, thus being able to dislodge more soil (Franklin, Hampden, Hampshire Conservation Districts, 2003). Site 1 also had no vegetation cover. Typically, large unprotected land areas have greater potential for erosion (Franklin, Hampden, Hampshire Conservation Districts, 2003).

Although site 4 had no BMP, the runoff sample from the area had a low turbidity of 41 ntu and total suspended solids of 132 mg/L. This may have been due to the soil type found in the area. The soil composition had medium soft to medium hard clay, sand, basalt pebbles and boulders. The larger particle sizes found at this site would have shorter transport distances and the larger pore spaces within the soil promote higher infiltration rates which decrease runoff (Lin, 2010). While site 4 had a steep slope angle (52.9% or 27.9 degrees), it also had approximately 30% natural vegetation cover which can help to minimize erosion. Overall, sites with BMPs had lower solids concentrations in the runoff than the clay site, likely due to soil differences. Most sites with BMPs had similar or lower solids in the runoff than site 4 (no BMP) with the exception of site 1, which had little vegetation.

4.2.3 RUSLE Soil Loss Estimates

The RUSLE equation was used to estimate the rate of soil loss for a square kilometer over a year. First, each of the parameters in the equation was determined from historical data or site assessment measurements. These parameters included rainfall erosivity factor (R), soil erodibility factor (K), length slope factor (LS), crop management factor (C), and the supporting practices factor (P). Then, these data were extrapolated from the the study period (November 14 – December 2, 2011) to 365 days. This analysis was completed for each of the six sites.

Rainfall values were calculated first (see Appendix B). Hourly rainfall measurements were obtained from the Cocoli meteorological station. The cumulative rainfall measurements with intensities are presented in Table 2. The rainfall intensity (I) was calculated as the rainfall amount for sample day divided by 24 hours. Then, the intensity was used to calculate the kinetic energy (E) using Equation 4. Lastly, the rainfall erosivity (R) was determined as the sum of the intensity time energy values. The R value was calculated for the study period as 245 and was the same for all sites. Due to the lack of long term measurements, this calculation was done under the assumption that the rainfall that occurred over the study period was consistent throughout the year, which may not be accurate due to differences between seasons. The R value calculated here is more representative of the rainy season and does not take into account the rainfall reduction in the dry season. This likely caused the calculated R values to be skewed higher than the values for both seasons.

Table 2 - Rainfall data for data collection period

Date	Time Elapsed (Hours)	Daily Rainfall Data (mm)	Cumulative Rainfall (mm)	Rainfall Intensity (mm/hr)
11/14/2011	24	0	0	0.00
11/15/2011	24	0	0	0.00
11/16/2011	24	11	11	0.46
11/17/2011	24	20	31	0.83
11/18/2011	24	16	47	0.67
11/19/2011	24	40	87	1.67
11/20/2011	24	22	109	0.92
11/21/2011	24	1	110	0.04
11/22/2011	24	7	117	0.29
11/23/2011	24	22	139	0.92
11/24/2011	24	0	139	0.00
11/25/2011	24	0	139	0.00
11/26/2011	24	9	148	0.38
11/27/2011	24	24	172	1.00
11/28/2011	24	17	189	0.71
11/29/2011	24	42	231	1.75
11/30/2011	24	8	239	0.33
12/1/2011	24	1	140	0.04
12/2/2011	24	0	240	0.00

Soil composition was determined from soil core data provided by the ACP Geotechnical Department. The logs provided data on the types of soils present in the given area, such as clay and basalt, and to what depth they extend to. The soil core logs for each site are presented in Appendix E. This information was used to estimate percentages of sand, organic matter and silt, and the percentages were compared to photographs taken of each site to support the estimated values. The estimated sand and organic composition percentages can be found in Appendix F. From these percentages, the soil erodibility (K) for each site's soil type was determined using the figure presented in Appendix B. The results for the K value are shown in Table 3. The calculated K values fall within typical ranges for the soils observed at the sites. Soils high in clay typically have K values between 0.05 – 0.15 and the estimated K for site 6 was 0.05, which falls within the allowable range for clay soils. Soils that are high in sands typically have K values between 0.05 – 0.20. Site 3 was found to have a soil that consisted largely of sand and the estimated K value was in the appropriate range. The soils with more organic matter such as silt, typically considered loams, have a K value between 0.25 – 0.65 (Jones, n.d.). Sites 1, 2, 4 and 5 all had soil that consisted of silt, and their estimated K-values were in the range of the loamy soils.

Table 3 - Percentage soil composition data and soil erodibility (K) values

Site #	% Sand	% Organic Matter	% Silt	K Value
1	30	1	50	0.35
2	30	1	50	0.35
3	50	0	20	0.20
4	40	1	40	0.33
5	30	1	40	0.22
6	10	1	20	0.05

Slope and slope length were used to determine the LS factor using Equation 5. Table 4 presents the values calculated for slopes (%) and slope lengths (m) for each site. These measurements are based on the specific slope segment of the locations of our erosion bridges. The NN value that is present for all sites is 0.5 as they all have slopes over 5%.

Table 4 - Length-slope data and final LS values

Site #	Slope Steepness (%)	Slope Length (m)	NN Value	LS Value
1	57	7.6	0.5	11
2	31	15.5	0.5	6
3	43	9.1	0.5	9
4	53	27.7	0.5	18
5	29	16.8	0.5	6
6	28	14.3	0.5	5

The crop-management factor (C) for each site was found by doing visual inspections of each site to estimate the vegetation cover and using Appendix B. The determined C values, based upon ground cover and percent ground cover, are presented in Table 5. The lowest crop management factors were found to be at the locations with hydroseeding with values between 0.002-0.003. The highest C values occurred where there was very little ground cover thus having the most exposed soil. Therefore, having sufficient soil cover is an important aspect for having less erosion.

Table 5 - Ground covering data and final C values

Site #	Ground Cover Type	Percent Ground Cover	C Value
1	Rocks	20	0.44
2	Hydroseeding	90	0.003
3	Basalt	90	0.03
4	Natural Vegetation	20	0.2
5	Hydroseeding	95	0.002
6	No Cover	0	0.1

The supporting practices factor (P) is based on crop rotation. As this does not apply to construction sites, the value is set equal to 1 (Pitt, 2004).

The parameters described above were used in the RUSLE equation to estimate the soil loss rate (A) in tons/acre/year or metric tons/km²/year for each site. A summary of the parameter values is shown in Appendix F, and the computed soil loss rates in Table 6. Also shown in this table are the soil loss rates estimated from the soil erosion bridges converted to tons/km²/year. The soil loss rates based on the RULSE equation varied from 7,600 metric tons/km²/year at site 5 (new hydroseeding and silt fencing) to 5,029,400 tons/km²/year at site 1 (silt fencing). Compared to site 4 with no BMP, sites 2, 3 and 5 (with BMPs) had erosion rates one to three orders of magnitude lower. Site 1, which had a silt fence but no vegetation cover, had a high soil loss rate. The estimates based on the erosion bridge data showed similar trends, with the no BMP site (site 4) having the highest estimated soil loss, and sites with BMPs had lower levels. Differences among sites with BMPs may be due to the type of BMP installed or other factors including the slope angle.

Table 6 - Estimated annual soil loss based on RUSLE equation and erosion bridge data

Site	Site Description	Estimated Soil Loss (tons/km ² /year)	
		RUSLE Equation	Erosion Bridge Data
1	Silt fences	5,029,400	568,300
2	Hydroseeding (established)	18,600	180,400
3	Terracing	146,600	296,500
4	No BMP	3,472,500	691,900
5	Hydroseeding and silt fences (new)	7,600	321,200
6	No BMP (clay)	71,700	39,500

While the trends in the estimated soil loss rate appear promising, the estimated values were high compared to values reported in the literature. Specifically, construction site erosion values range from 7.2 to over 1000 tons per acre per year or 1,780 to 247,100tons/km²/year (Jin & Englande Jr, 2009). In this project, estimates ranged from 7,600 to 5,029,400 tons/km²/year by the RUSLE equation, and 39,500 to 691,900 tons/km²/year based on soil erosion bridge data. The values from the RUSLE equation and soil erosion bridge data were also typically different by an order of magnitude but not consistently. It was noted previously that the erosion bridge data were collected over a limited time frame. For the RUSLE equation, errors may have been introduced in our calculations as follows. First, rainfall intensity that was used to calculate R values was based on 18 days of data, rather than a year of data. Next, while the K values fell within the average range for the types of soils present, data on exact percent composition of each soil type at each site was not available. Third, the LS factors were determined using Equation 5; however, several different equations exist for this factor. No two references analyzed used the same equation to determine the LS factor. Finally, the C values were estimates based upon observations. Further research to correct these limitations is recommended.

4.2.4 Rainfall versus Erosion Bridge Soil Loss Estimates

Data were recorded from the erosion bridges at each site for a period of 18 days. A total of 240 mm of rainfall was recorded by the Cocoli hydro meteorological station during that time period. The rainfall intensity was calculated based on 24 hour rainfall amounts which ranged from 0.04 mm/hour to 1.75 mm/hour. The soil loss at sites 1, 2, 3 and 5 are compared to the control area of site 4 in Figure 30. These sites had silt fences (site 1), hydroseeding (site 2), hydroseeding and silt fences (site 5), terracing (site 3) and the no BMP (site 4). The cumulative rainfall data for days 0 to 18 are also included in this plot.

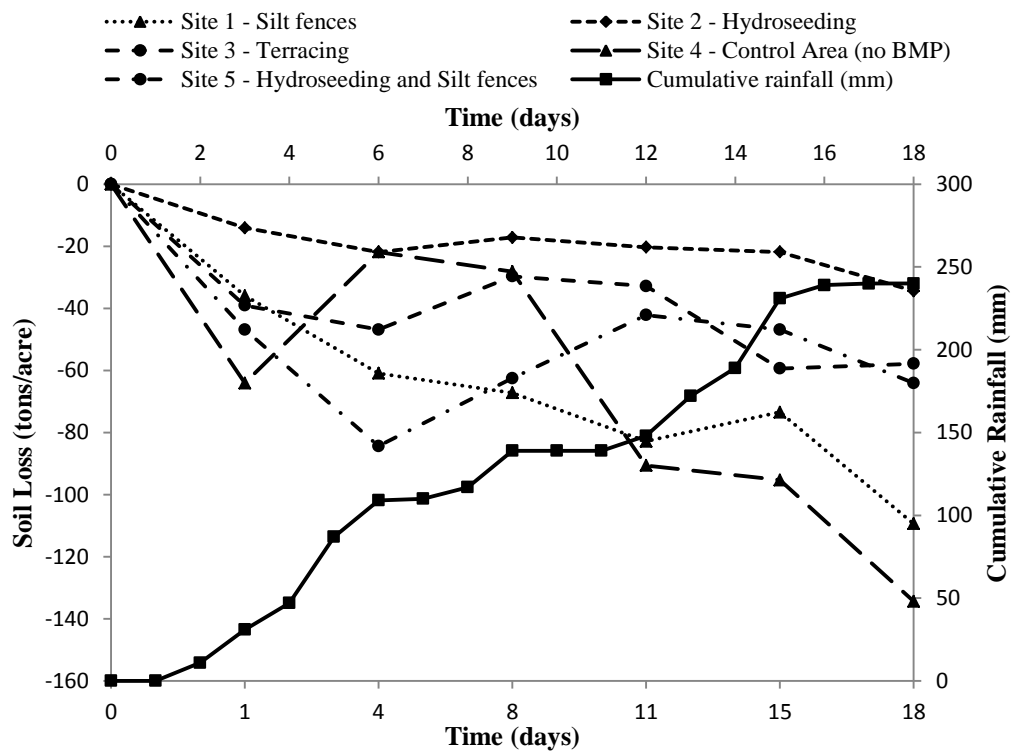

Figure 30 - Comparison of soil loss from BMP areas (sites 1, 2, 3 and 5) with control area (site 4) and cumulative rainfall data

There was soil loss recorded for all sites between day 0 and day 1; however, the cumulative rainfall data indicated no rainfall occurred during this period. The reduction in soil height may have been due to the removal of the water content of the soil. Volume changes in soil can occur from the removal of water (shrinkage) or the addition of water (swelling) (Breemen & Buurman, 1998). On day 1 of measurement, the soil was wet and runoff was flowing in the drainage culverts (see Figure 15). This indicated that rainfall occurred prior to the installation of the erosion bridges. Overall, the control area (site 4) had the greatest soil loss of approximately 140 tons/acre. While both increases and decreases in soil height were observed on different days, all sites with BMPs showed an overall soil loss from day 0 to 18 and all sites with BMPs had less erosion over the test period than the site with no BMP. Specific patterns or trends of soil loss

compared to cumulative rainfall were not apparent other than an overall trend of increased soil loss with time.

In addition to cumulative rainfall, the soil loss data were plotted versus rainfall intensity (see Figure 31). In general, areas with high-intensity precipitation and frequent rainfall experience higher rates of erosion (Franklin, Hampden, Hampshire Conservation Districts, 2003). The maximum rainfall intensity during the test period was 1.75 mm/hr on day 15 and the second highest was 1.67 mm/hr on day 5. However, soil profiles were not measured every day. As a consequence, trends between soil profiles and rainfall intensity are not apparent.

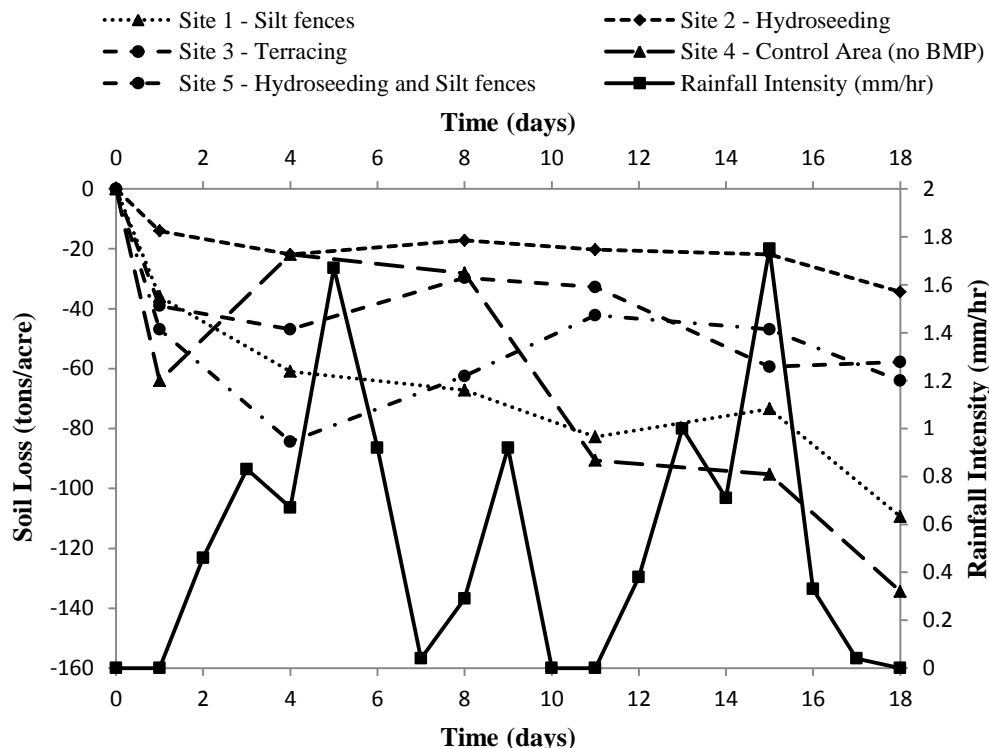

Figure 31 - Comparison of soil loss from BMP areas (sites 1, 2 and 3) with control area (site 4) and rainfall intensity

4.2.5 Statistical Comparison of Erosion Loss Estimates

An analysis of variance (ANOVA) test was completed to determine if there were statistically significant differences in soil loss among sites 1 – 5. The soil loss data obtained from the erosion bridges were used for this analysis because the bridges were a direct measurement tool as opposed to the estimation involved in using the RUSLE equation. This test was completed using the Statistical Package for Social Science (SPSS) 20.0 software using a 95% confidence level (alpha = 0.05). Results showed that there was a statistically significant difference in soil loss among the sites, $F(4, 25) = 5.16, p = 0.004$.

While the ANOVA showed there is a statistically significant difference in soil loss among the sites, it does not specify which sites are different from each other. The Student Newman-Keuls and Tukey HSD Post-Hoc ANOVA analyses were used to find the sites that were significantly different from each other. The results of these tests are shown in Appendix G. From Table G-4 of the Tukey HSD Post-Hoc results, the control area (site 4) and site 2 (hydroseeding) had a significant difference in soil loss ($p = 0.007$). Also, site 2 (hydroseeding) and site 1 (silt fences) had significantly different amounts of soil loss ($p = 0.005$). No other differences in soil loss among sites were found. Thus, site 2 with established hydroseeding had less soil erosion than the site with silt fencing (site 1) and the site with no BMP (site 4).

4.2.6 Distance from Blasting

Blasting involves the controlled use of explosives for excavation or removal of rocks. The Pacific sector of the Panama Canal Expansion project has volcanic extrusions of basalt in its soil structure. Basalt is a dark, hard and dense igneous rock, which requires greater force to break up its structure than that provided by machinery. The distance of the erosion bridge locations from these blasting sites was assessed as a factor that may have affected soil erosion rates in the area.

The Pacific sector had two active blasting zones during our project: Pacific Access Channel (PAC) area 0, with two blasting locations and PAC 4, with six blasting locations. The erosion bridge locations in PAC 0 were sites 1, 2 and 3. The locations in PAC 4 were sites 4, 5 and 6. Within PAC 0, the distance from each blasting location to each site was measured, and the average distance from blasting to site was calculated. This was repeated for PAC 4. Seismographic data and the average maximum instantaneous charge (maximum amount of explosive used in kg for each blasting) were also obtained from the ACP for each blasting that occurred during the study period (see Appendix H). The average of the maximum instantaneous charge and distance from blasting had to be calculated as the intensity that occurred at each specific site could not be measured. The scaled distance factor is used to provide an estimate of how intensity would change with distance if each site was monitored. Table 7 shows the average distance from the blasting locations, average maximum instantaneous charge of each blast, and the soil loss rate of each site (based on erosion bridge data).

Table 7 - Comparison between distance from blasting and soil loss rate based on erosion bridge data

Sites	Average Distance from Blasting (m)	PAC	Average Maximum Instantaneous Charge (kg)	Soil Loss Rate (metric tons/km ² /year)	Scaled Distance Factor (m/kg)	Peak Particle Velocity (PPV) (m/s)
1	1130	PAC 0	230	568,300	80	0.1
2	1050	PAC 0		180,400	70	0.2
3	520	PAC 0		296,500	30	0.7
4	2120	PAC 4	10210	691,900	20	1.3
5	1150	PAC 4		321,200	10	4.0
6	1150	PAC 4		39,500	10	4.0

The scaled distance factor and the peak particle velocity (PPV) were calculated. The results are also shown in Table 7. The scaled distance factor was calculated used the average maximum instantaneous charge and the average distance from the blasting locations of each site (Equation 7). The peak particle velocity was calculated using Equation 6. Sites 5 and 6 were the nearest to the blasting according to the scaled distance factor (10 m/kg) and site 1 was the furthest with a scaled distance of 80 m/kg. Sites 5 and 6 had the largest peak particle velocity value of 4.0 m/s, while the peak particle velocity at site 1 was 0.1 m/s. This indicates that as the ground vibrations propagate further away from the source, the energy is dissipated (Vibra-Tech Engineers, Inc., 2008). Site 1 had the largest scaled distance and the least peak particle velocity but it had the second highest soil loss rate of 568,300 tons/km²/year. Sites 5 and 6 had the smallest scaled distance and the largest peak particle velocity, but site 6 had the lowest soil loss rate. The scaled distances for each site were plotted against the peak particle velocity in Figure 32, which shows that as distance increases, the ground vibration decreases.

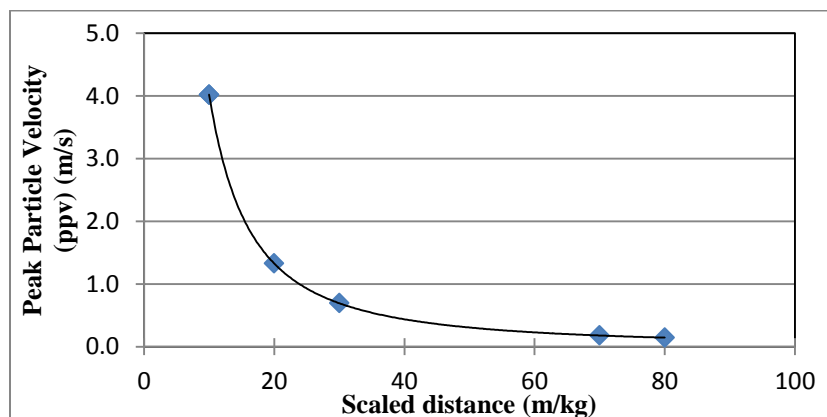

Figure 32 - Relationship between ground vibration level (PPV) and separation scaled distance

The seismographic data obtained from the ACP was also used to show the relationship between ground level vibrations and distance from blasting. The event report from each blasting during our study period is shown in Appendix H. These reports from the seismographs at different monitoring stations had the peak particle velocity in three components: longitudinal, transverse and vertical directions. The distance of each monitoring station and the maximum instantaneous charge used at each blasting was also recorded. The map showing the locations of the blasting locations and the monitoring stations is also shown in Appendix H. The three components of the peak particle velocity and the calculated scaled distance of each monitoring station from the blasting locations were plotted against each other in Figure 33.

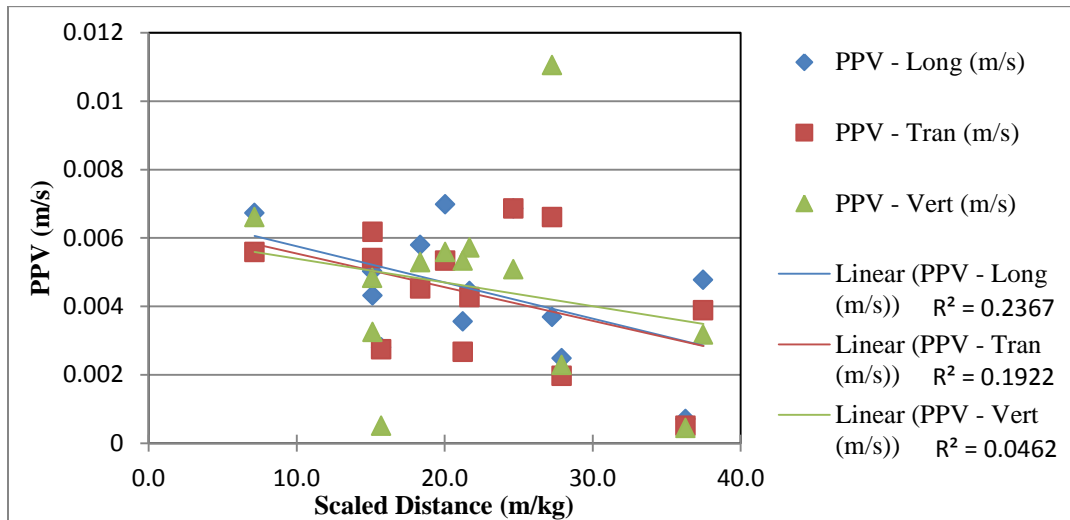

Figure 33 - Relationship between ground vibration level and scaled distance from blasting

Figure 33 shows that as distance increased, the vibration energy generally decreased. However, linear regression trend lines were a poor fit to the data, with correlation coefficients ranging from 0.05 to 0.24. From Table 7 it was found that there was no relationship between soil loss rate and ground vibration levels or distance from the blasting. The decrease in vibrational energy with increasing distance from blast did not cause a decrease in soil loss rate. The site with the largest scaled distance from the blast had the second largest soil loss rate and the sites closest to the blast were among the lowest soil loss rates.

4.3 Evaluation of Soil Erosion Mitigation BMPs

Soil erosion mitigation BMPs in the Pacific sector of the Panama Canal expansion program were evaluated for applicability, effectiveness, and cost. Specifically, silt fences, hydroseeding and terracing were ranked on six criteria: short term effectiveness, applicability to different slope angles, applicability to different soil types, effectiveness without additional BMPs, estimated soil loss prevented, and installation and maintenance costs. Each BMP was ranked for each criterion on a scale from 1 to 3, where 1 = poor, 2 = neutral and 3 = good. A summary of the ratings is shown in Table 8.

Table 8 - Evaluation of soil erosion mitigation BMPs in Panama Canal expansion area

Criteria	Ranking		
	Silt Fences	Hydroseeding	Terracing
Short Term Effectiveness	3	1	2
Applicability to Different Slope Angles	1	3	1
Applicability to Different Soil Types	1	3	1
Effectiveness without Additional BMPs	2	2	1
Estimated Soil Loss Prevented	1	3	2
Cost of Installation and Maintenance	2	1	3

The first criterion was the short term effectiveness of the BMPs. This refers to whether the BMP controls erosion immediately upon installation. Silt fences are effective immediately because they act to trap and filter sediment, and thus received a good ranking (rank = 3). Silt fences are considered temporary control measures. Terracing involves the shortening of flow lengths on long, steep slopes by cutting it into segments using relatively flat sections or terraces (Urban Drainage and Flood Control District, 2010). This helps to reduce the formation of rills and gullies, but it is recommended that it be used in combination with other erosion control measures, and therefore received a neutral ranking (rank = 2). Hydroseeding is a permanent erosion control practice that involves the germination of the seeds which depends on the weather, time of year, amount of water and other factors. Typically, the grass grows in 5-7 days (Earth Groomers, n.d.; NDDoH, 2001). However, additional time is needed for grass and other plant growth to become fully established. Our results showed that hydroseeding was more effective after longer periods (see section 4.2.2). Sites 2 and 5 had hydroseeding installed but site 2 had less soil loss as the grass had been installed in October of 2009, compared to August 2011 for site 5. Therefore, hydroseeding would not be effective for short term erosion control since there would be less vegetation cover and shallow roots (rank = 1).

The second criterion was whether the BMP can be applied to different slope angles. Silt fences have limited applicability: their use is restricted to slopes of no greater than 4:1 (base: height) or 25% (California Storm water Quality Association, 2003). Silt fences were installed at site 1, which had the steepest slope (56.6% or 29.5 degrees) among the sites and the second largest turbidity, total suspended solids and soil loss rate among the sites. However, silt fences were also used with hydroseeding at site 5 that had a slope of 29.4% or 16.4 degrees. The soil loss rate from site 5 was 1,300 tons/acre/year, which was less than site 1 of 2,300 tons/acre/year. Hydroseeding was applied at sites 2 and 5 which both had slope angles of approximately 30%, and therefore no conclusion can be drawn on slope applicability based on the field data. Terracing was applied at site 3, with a slope of 43.4% or 23.5 degrees, and the soil loss rate was 1,200 tons/acre/year. Overall, silt fences and terracing were ranked 1, and hydroseeding was ranked 3.

Soil type also plays a role in the placement of silt fences. Sandy soils might require more silt fence per area to contain the volume of potential sediment in runoff, while clay soils might need fewer fences because the volume of potential sediment loss is less, but the volume of water might be greater because clay soils allow less rainfall infiltration (Enviro-Pro Geosynthetics Ltd., 2011). In our field work, we observed hydroseeding at site 2 in a well-mixed soil composition of sand, clay and silt, and at site 5 in clay with basalt pebbles and rocks. The hydroseeding at site 5 had grown to a significant height, which means that hydroseeding can be applied to different soil types. As discussed in section 4.1.3, terracing has limited applicability on different slopes due to soil type. The terracing at site 3 had large basalt rocks, with large pores which promoted high infiltration but this would not be the same effect for clay or sand with smaller pores. In summary, hydroseeding was ranked with good applicability to different soil types, while fencing and terracing were ranked poor.

The fourth criterion was if the BMP was effective alone. In our field work, we observed hydroseeding alone, silt fences alone, terracing alone, and hydroseeding combined with fencing. The established hydroseeding was the most effective based on soil erosion bridge data (lowest yearly loss rate); however, other factors at the sites (slope, soil time and time since implementation) may have affected soil loss rates. Therefore, it is difficult to draw conclusions based on these field data and statistical analysis because they did not show differences between the single and combined BMPs. However based on the literature, terracing is better when used in combination with other BMPs (Urban Drainage and Flood Control District, 2010), thus it received a poor ranking (rank = 1). Silt fences and hydroseeding were given a neutral ranking (rank = 2) because the installation of silt fences below good vegetative cover removes sediment from storm water runoff more effectively than the use of silt fences alone (Angus et al., 2002) and hydroseeding may be used alone only when there is sufficient time to ensure adequate vegetation establishment and erosion control. Otherwise, hydroseeding must be used in conjunction with other BMPs (California Stormwater Quality Association, 2003).

The estimated soil loss prevented was based on the erosion rates measured using soil erosion bridges, RUSLE equation estimates, and previous research. Soil loss was least at site 2 with hydroseeding (based on soil erosion bridge data) and at site 5 with hydroseeding and silt fencing (based on RUSLE estimates). Hydroseeding is proposed to be the most efficient and cost-effective permanent BMP due to its one time application and low maintenance (North Dakota Department of Health, 2001). The least effective BMP at preventing soil loss was silt fences which had the highest soil loss rate among the BMP sites (2,300 tons/acre/year using the erosion bridge data). USEPA (1993) reports that silt fences constructed of filter fabric that are properly installed and well maintained can remove 70% of total suspended solids, 80 – 90% of sand, 50 – 80% of silt-loam, and 0 – 20% of silt-clay-loam. Removal effectiveness highly depends on local conditions and installation techniques. Silt fences are usually used on construction sites with relatively small drainage areas and are appropriate in areas where runoff will be low-level shallow flow, not exceeding 0.5 cfs. Terracing had a moderate soil loss rate based on both the RUSLE equation estimates and the erosion bridge data. The main purpose of terracing is to

reduce runoff velocity and soil erosion by breaking the effective length of slopes and also to promote infiltration (Naderman et al., 1990). Infiltration however depends on soil type, so terracing would not be effective for clay soils due to the slow infiltration rate and high runoff. In summary, hydroseeding received a good ranking, terracing neutral, and silt fences poor.

The last criterion was the BMP cost. Installation costs include the price of materials and labor for implementing the BMP, while maintenance costs include materials and labor for repairs and regular maintenance. The locks contractor estimated the cost of hydroseeding, neglecting maintenance, to be USD \$2 per square meter and the PAC 4 contractor stated that hydroseeding, with maintenance, costs USD \$8.60 per square meter. Other estimates indicate that hydroseeding has an installation cost of \$0.75 – \$1.94 per square meter (\$0.07 – \$0.18 per square foot) (Earth Groomers, n.d.; NDDoH, 2001). Hydroseeding requires little maintenance. Silt fencing was estimated to cost USD \$14 per meter (\$4.50 per linear foot) for installation based on the locks contractor's estimates. Other estimates place the average annual cost for installation and maintenance of silt fences at USD \$22 per meter (\$7 per linear foot) if a useful life of 6 months is assumed (California Stormwater Quality Association, 2003; NDDoH, 2001). Silt fences also require little maintenance. The drainage area for silt fences generally should not exceed 0.25 acre per 30 meter (100 feet) fence length (NPDES, 2006; Metropolitan Council/Barr Engineering Co., 2001). Thus for an acre it would require 120 meters (400 feet) of silt fence, which at a price of USD \$22 per meter (\$7 per linear foot) for installation and maintenance would amount to a cost of USD \$2640 per acre. For installation only, at USD \$14 per meter (\$4.50 per linear foot) the cost would be USD \$1680 per acre. Terracing is a style of land shaping but it requires capital investments to obtain the equipment to build the terraces. Depending on the type of terracing (bench, contour or parallel) the installation and maintenance costs range from USD \$0.02 to \$0.06 per square meter (\$100 to \$250 per acre) (Schottman & White, 1993). Other sources estimate the cost to range from USD \$0.07 –to\$ 0.12 per square meter (\$300 to \$500 per acre) (PM10 Inc., 2007). Overall, hydroseeding received poor ranking, silt fences neutral and terracing good.

As shown in Table 8, hydroseeding received the highest ranking among the three BMPs, but is not applicable for short term erosion control. Silt fences provide immediate erosion control and have reasonable costs, but are limited in terms of applicability. Terracing can be applied over a long or short term, prevents soil loss and can be applied without additional BMPs, but it has limited applicability to different soil types and slope angles.

5.0 CONCLUSIONS AND RECOMMENDATIONS

This chapter provides a summation of the results found. Conclusions are made based on the data gathered from the soil erosion bridges at each of our six sites, RUSLE calculations and research performed. Recommendations are made for each site and a BMP design for future sites. Our recommendations for further study are also presented.

5.1 Conclusions

Soil erosion was monitored at six sites in the Pacific Lock sector of the Panama Canal expansion program. Four sites had best management practices installed to control soil erosion, including terracing, silt fences and hydroseeding. At each of the sites, a soil erosion bridge was installed and soil height was monitored over 18 days. Soil loss estimates were extrapolated to yearly soil loss rates. Turbidity and suspended solids in runoff were used as a second quantitative measure of erosion. A third estimate of annual erosion rates was based on the Revised Universal Soil Loss Equation using data gathered on rainfall, land cover, and soil types. Lastly, interviews with contractors were completed to gather information on pricing, observations, and effectiveness of best management practices they installed.

Results showed that sites with hydroseeding installed, sites 2 and 5, had the lowest soil loss rates among the sites with BMPs. The site with established hydroseeding had a statistically lower soil loss rate (as estimated by soil erosion bridge data) than the site with no BMP. Also, the site with established hydroseeding had a statistically lower soil loss rate than the site with silt fencing. However, soil loss rates determined in this study tended to be higher than typical rates for construction sites. This may have been due to the limited time frame of the field investigation, limitations on the data available for computation of soil loss via the RUSLE equation and above average rainfall in Panama compared to most construction sites. Interviews with the contractors for both the locks and PAC 4 confirmed that no one single erosion control method is best for all situations.

5.2 Site Recommendations

Specific recommendations for each of the study sites are provided here. Site 1 has silt fences, and there was no statistically significant difference in soil loss at this site and the site with no BMP (site 4). Thus, additional BMPs should be implemented at site 1. Based on the effectiveness of hydroseeding, it is recommended that hydroseeding be added to the existing silt fencing. For site 2, the current implementation of hydroseeding is controlling erosion to a great degree and this site requires no other BMP. At site 3, we recommend the addition of hydroseeding to the terracing already in place. Terracing should be combined with other stabilization measures that provide cover for exposed soils such as mulching, seeding, surface roughening, or other measures (Urban Drainage and Flood Control District, 2010). At site 4, there are plans to reconstruct the area, and we recommend a slope of approximately 30% at this site. Based on the

soil erosion bridge data, site 2 had the lowest soil loss rate and had a slope angle of approximately 30%. For site 5, the current BMPs that are installed, silt fencing and hydroseeding, are working well and no changes are recommended. Finally, for site 6, which is composed largely of clay, we recommend adding silt fencing.

5.3 BMP Design Recommendation for Future Sites

For future disposal sites, we recommend implementation of multiple BMPs to control erosion since no one single erosion control was found to be applicable to all situations. Our recommendations are based upon field observations (erosion bridge data, runoff analysis and RUSLE soil loss estimates) at each of the six sites that were chosen, interviews with ACP contractors and additional research. The combination of hydroseeding and silt fences at site 5 had a soil loss rate of 1,300 tons per acre per year (erosion bridge data), which would be a viable option. However, we also recommend the addition of terracing as shown in Figure 34. Terracing allows for long, steep slopes to be broken into segments, which reduces the velocity of the runoff, promotes infiltration and mitigates soil loss as opposed to if it was one uninterrupted flow that would cause the formation of rills and gullies (Urban Drainage and Flood Control District, 2010). The terraces would also facilitate the settling of sediments from the ponded water which can then percolate through the silt fences (California Stormwater Quality Association, 2003).

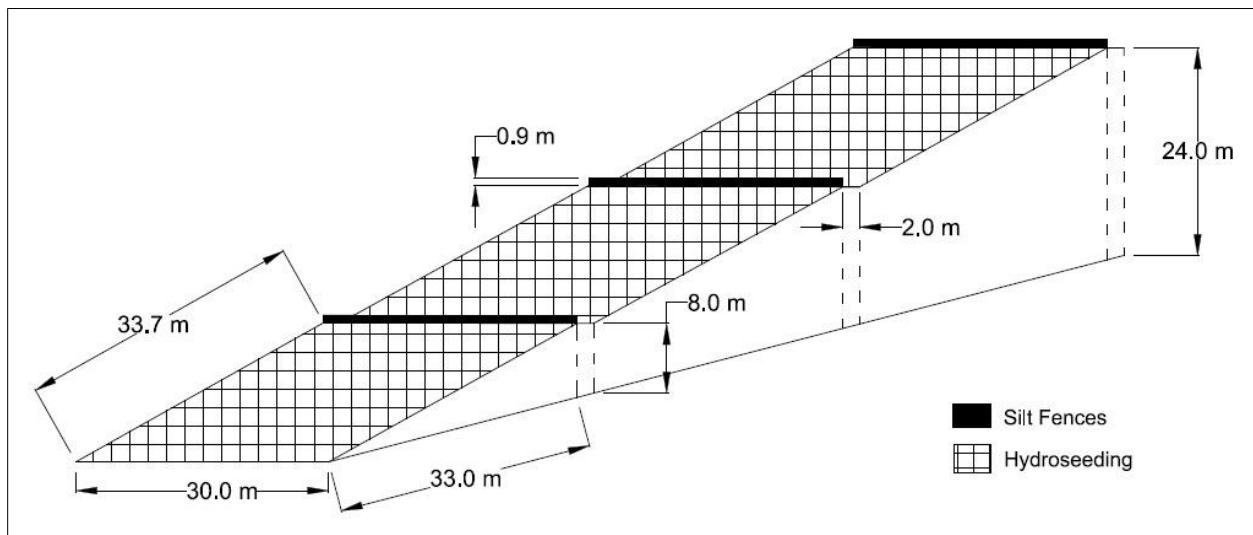

Figure 34 - Recommended design of an effective erosion control plan

The recommended design was completed for a hillside 30 m wide and 105 m long. The width of the hillside is based on the drainage area for silt fences, which should not exceed 1,012 square meters (0.25 acre) per 30 meter (100 feet) fence length (NPDES, 2006; Metropolitan Council/Barr Engineering Co., 2001). The length of 105 m is a summation of each of the three slope lengths of 33 m, which was calculated based on the effective slope angle for silt fences of no greater than 25% (4:1 (base: height)) and the width of each terrace, which was 2 m. The width

of terraces varies between 2 m to 5 m (Chamberlain, 1990). This design can be scaled to larger sites.

Terraces are generally suitable for slopes up to approximately 50%, depending on the type of terracing (Chamberlain, 1990). Silt fences are restricted to slopes no greater than 25% (4:1 (base:height) and steep slopes are difficult to protect with hydroseeding (California Stormwater Quality Association, 2003). The slope angle for the design is 25% based on the restrictions of the silt fences. From the erosion bridge data, site 2 (hydroseeding) had the lowest soil loss while the RUSLE estimate showed that site 5 (hydroseeding and silt fences) had the lowest soil loss rate among the sites with BMPs. Both had slope angles of approximately 30%. Thus, the decrease in slope angle will be more effective at mitigating soil loss.

The purpose of the silt fences is to reduce the velocity of sheet flow run-off and provide filtration. The silt fences are placed at the end of each terrace, above each hydroseeded slope. The terraces facilitate the settling which occurs when there is a reduction of the velocity of the incoming flow from the hydroseeded slopes which results in ponding of the water. As the water percolates through the silt fence fabric, much of the suspended sediment is filtered out before it enters the following slope. Silt fences placed at the toe of a slope must also be set at least 1.8 meters (6 feet) back from the toe to increase ponding volume and provide room for maintenance. The height of a silt fence should not exceed 0.9 meters (36 inches) as higher fences may impound volumes of water sufficient to cause failure of the structure. The filter fabric should be a pervious sheet of propylene, nylon, polyester or ethylene yarn (Comprehensive Environmental Inc. & NHDES, 2008). Lastly, hydroseeding would be applied along the hillside. This would provide additional soil stabilization, which was found to be effective at site 2 (hydroseeding only) and site 5 (hydroseeding and silt fences).

The estimated cost of installing hydroseeding is USD \$2 per square meter (locks contractor), while the estimated cost of installation and maintenance is USD \$8.60 per square meter (PAC 4 contractor). The drainage area of each slope segment is 1,012 square meters (33.7 m long and 30 m wide). Thus, the total area for all three slopes to be hydroseeded is 3,036 square meters. The total cost for installing hydroseeding for this design would be USD \$6,070. The cost considering installation and maintenance at USD \$8.60 per square meter would be USD \$26,100. Silt fences were estimated to cost USD \$14 per meter (\$4.50 per linear foot) for installation based on the locks contractor's estimates. Other estimates place the average annual cost for installation and maintenance of silt fences at USD \$22 per meter (\$7 per linear foot) if a useful life of 6 months is assumed (California Stormwater Quality Association, 2003; NDDoH, 2001). The total length of silt fencing required for this design would be three lengths of 30 m, which is 90 m. Therefore for installation at USD \$14 per meter, the cost would be \$1,260 and at USD \$22 per meter for installation and maintenance, cost would be USD \$1,980. The installation and maintenance costs of terracing range from USD \$0.02 to \$0.06 per square meter (\$100 to \$250 per acre) (Schottman & White, 1993). Other sources estimate the cost to range from USD \$0.07 to \$0.12 per square meter (\$300 to \$500 per acre) (PM10 Inc., 2007). Terracing would be applied to a greater area

than hydroseeding, which would include the area for each terrace. The total area would be 3,240 square meters. Based on both estimates for the installation and maintenance of terracing the total cost would range from approximately USD \$70 to USD \$390. The total cost for the design with hydroseeding, silt fences and terracing (including installation and maintenance) is approximately USD \$28,480.

Table 9 - Summary of cost assessment for BMP design recommendation

BMP	Total units required	Costs per unit (USD)		Total cost for design (USD)	
		Installation	Installation and Maintenance	Installation	Installation and Maintenance
Hydroseeding	3,036 m ²	\$2/m ²	\$8.60/m ²	\$6,070	\$26,110
Silt Fences	90 m	\$14/m	\$22/m	\$1,260	\$1,980
Terracing	3,240 m ²	-	\$0.02 – 0.12/m ²	-	\$390
Total				\$7,330	\$28,480

5.4 Recommendations for Further Study

During the completion of this project there were several limitations. Soil erosion bridges used were only in place for 3 weeks; we recommend that future erosion bridges are in place for 8 months and the bridges constructed of the materials given in Figure 10 of section 2.4.3.1 to ensure accurate readings (Jin & Englande Jr, 2009). There are also other erosion control evaluation techniques, such as tracking cesium-137 levels in the soil and erosion plots that are more costly and require a longer observation time. Also, more complete data should be obtained for use in the Revised Universal Soil Loss Equation.

Six sites with different erosion control measures in place were studied. We recommend developing test sites where BMPs can be evaluated side-by-side. As the Panama Canal Expansion project comes to a close in 2014, long term erosion control measures should be evaluated to predict the performance of the BMPs recommended.

Erosion controls are vital to the sustainability of an area that undergoes land reshaping during construction. Maintaining best management practices of hydroseeding, terracing, and silt fencing, can prevent excessive erosion in the expansion area. Shifting ACP's focus from the qualitative inspection of the clarity of the runoff, to more quantitative measures of erosion control effectiveness may enable a more robust understanding of soil erosion within the Panama Canal basin.

BIBLIOGRAPHY

- American Public Health Association (APHA); American Water Works Association (AWWA); Water Environment Federation (WEF). *Standard Methods for the Examination of Water and Wastewater* (21st ed.). American Public Health Association (APHA): Washington D.C., 2005.
- Angus, R. A.; Lalor, M. M.; Marion, K. R. *Studies to Evaluate the Effectiveness of Current BMPs in Controlling Stormwater Discharges from Small Construction Sites*. State Water Resources Research Institute: Birmingham, 2002.
- Bennet, I. E. *History of the Panama Canal*. Historical Publishing Company: Washington D.C., 1915.
- Blaney, D.; Warrington, G. *Estimating Soil Erosion Using an Erosion Bridge*. USDA Forest Service, Watershed System Development group: Fort Collins, CO, 1983.
- Breemen, N. v.; Buurman, P. *Soil formation*. Kluwer Academic Publishers: Dordrecht, The Netherlands, 1998.
- California Stormwater Quality Association. *California Stormwater BMP Handbook Construction* [Online], January, 2003. Stormwater Best Management Practice (BMP) Handbooks.
- Carpenter, T. *Proper Silt Fence Installation* [Online], 2006. Land and Water: The Magazine of Natural Resource Management and Restoration.
- Chamberlain, J. *Understanding soil erosion and its control*. VITA: Arlington, 1990.
- Clayton, K. C. *7 CFR Part 610*. Natural Resource Conservation Service, USDA: Washington D.C., 1996.
- Climatetemp.info. *Panama Climate Guide*. <http://www.climatetemp.info/panama/> (accessed October 2, 2011).
- Comprehensive Environmental Inc.; New Hampshire Department of Environmental Services. *New Hampshire Stormwater Manual Volume 3: Erosion and Sediment Controls During Construction*. New Hampshire Department of Environmental Services: Exeter, 2008.
- Cooperative Extension Service, University of the Virgin Islands and Division of Environmental Protection V.I. Department of Planning & Natural Resources. *Sediment and Erosion Control on Construction Sites Field Guide*. University of the Virgin Islands Cooperative Extension Service: Virgin Islands, 2002.
- Earth Groomers. *Hydro-seeding & Erosion Control*. Earth Groomers: Healthy Landscapes for Better Living. <http://www.earthgroomers.com/services/hydro-seeding.html> (accessed September 23, 2011).
- Enviro-Pro Geosynthetics Ltd. *Silt Fences*[online], 2011. Enviro-Pro Geosynthetics Ltd.
- Franklin, Hampden, Hampshire Conservation Districts. *Massachusetts erosion and sediment control guidelines for urban and suburban areas*. Massachusetts Executive Office of Environmental Affairs: Northampton, MA, 2003.
- Goethals, G. W. *The Panama Canal*. National Geographic Society, 1911.
- Hartman, J. Combination of Technologies Improves Costal Erosion Measurements. *Civil Engineering*. 2001, 33.

- Headquarters, W. *Miraflores Lock*.
<http://www.worldheadquarters.com/panama/destinations/locks/> (accessed September 23, 2011).
- Jin, G.; Englande Jr, A. A field study on cost-effectiveness of five erosion control measures. *Management of Environmental Quality: An International Journal*. 2009, 20(1), 6-10.
- Jones, D.K. *Calculating Revised Universal Soil Loss Equation (RUSLE) Estimates on Department of Defense Lands: A Review of RUSLE Factors and U.S. Army Land Condition-Trend Analysis (LCTA) Data Gaps*. Department of Forest Science, Colorado State University: Fort Collins, CO, n.d.
- Lin, B. *Surface Runoff* [online], 2010. Encyclopedia of Earth.
- Marion, K. R.; Angus, R.; Lalor, M. *Implementation of methods to enhance the evaluation of the effectiveness of current BMPs in controlling stormwater discharges from mall construction sites in the Valley and Ridge physiographic region and the development of metrics to assess the effects of*. [Online], March 1, 2000. USGS: Water Resources Research Grant Proposal.
- Meditz, S. W.; Hanratt, D. M. *Panama: A Country Study*. GPO for the Library of Congress: Washington, 1987.
- Metropolitan Council/Barr Engineering Co. *Minnesota urban small sites BMP manual*. Metropolitan Council Environmental Services: St. Paul, MN, 2001.
- Meyer, L.; Wischmeier, W. Mathematical simulation of the process of soil erosion by water. *Transactions of the American Society of Agricultural Engineers*. 1969, 12, 754-758, 762.
- Minnesota Department of Agriculture. *Streambank and Lakeshore Protection*. [Online], 2011. Conservation Practices Minnesota Conservation Funding Guide.
- Naderman, G., Hansard, J.; Denton, H. Surface water management for crop production on highly erodible land. *Applied Agricultural Research*. 1990, 4, 5.
- National Pollutant Discharge Elimination System (NPDES). *Silt fences*. [online], 2006. US Environmental Protection Agency.
- North Carolina Sedimentation Control Commission (NCSCC); North Carolina Department of Environment and Natural Resources (NCDENR); North Carolina Agricultural Extension Service (NCAES). *Erosion and Sediment Control Planning and Design Manual (Chapter 2)*. [online], 2006, June 1. North Carolina Department of Environment and Natural Resources.
- North Dakota Department of Health. *A Guide to Temporary Erosion Control Measures for Contractors, Designers and Inspectors*. North Dakota Department of Health, Division of Water Quality: Bismarck, ND, 2001.
- Novotny, V. *Water quality: diffuse pollution and watershed management* (2nd ed.). John Wiley and Sons, Inc.: New York, 2003.
- Ocean Depot, S.A. Home Page. <http://www.oceandepotsa.com/en/> (accessed September 18, 2011).
- Panama Canal Authority. *Proposal for the Expansion of Panama Canal*. Panama Canal Authority: Panama City, 2006.
- Panama Canal Authority. *Read Our History*. [Online], 2011. Canal De Panama.

- Panamacruise.com.pa. *Panama Canal Facts*. Panamacruise.com.pa.
<http://www.panamacruise.com.pa/page-About+Panama+Canal-24.html> (accessed September 20, 2011).
- Pidwirny, M. *Introduction to Soils*. [online], 2006. Fundamentals of Physical Geography.
- Pitt, R. *Module 4: Erosion Mechanisms and the Revised Universal Soil Loss Equation (RUSLE)*. University of Alabama: Alabama, 2004.
- PM10 Inc. *Erosion Control - Terracing*. [online], 2007. PM10 Inc.
- Rickson, R. Controlling sediment at source: an evaluation of erosion control geotextiles. *Earth Surface Processes and Landforms*. 2006, 31, 550-560.
- Schottman, R. W.; White, J. *Choosing Terrace Systems*. [online], 1993. University of Missouri Extension.
- South Fayette Conservation Group. *Fishing Run Restoration/Maude Mine Reclamation*. [Online], May 24, 2008. South Fayette Conservation Group.
- Stone, R. *Universal Soil Loss Equation*. Ontario Ministry of Agriculture, Food and Rural Affairs: Ontario, 2000.
- Urban Drainage and Flood Control District. *Urban Storm Drainage Criteria Manual Volume 3, Best Management Practices*. Water Resources Publications, LLC: Denver, 2010.
- URS Holdings, Inc. *Category III Environmental Impact Study; Panama Canal Expansion Project - Third Set of Locks*. URS Holdings, Inc.: Panama City, 2007.
- U.S. EPA. *National Menu of Stormwater Best Management Practices*. [Online], January 9, 2008. National Pollutant Discharge Elimination System (NPDES).
- U.S. EPA (U.S. Environmental Protection Agency). *Guidance Specifying Management Measures for Sources of Nonpoint Pollution in Coastal Waters*. EPA 840-B-92-002. U.S. Environmental Protection Agency, Office of Water: Washington, DC, 1993.
- Vibra-Tech Engineers, Inc. *Blasting plan and impact analysis Liberty Quarry, County of Riverside, California*. [online], 2008, April. Riverside County Transportation & Land Management Agency.
- Wanielista, M.; Kersten, R.; Eaglin, R. *Hydrology: Water Quality and Quality Control* (2nd ed.). John Wiley & Sons, Inc.: New York, 1997.
- Wright, R. *Panama hope - a bigger canal can bring east and west closer*. [Online], October 19, 2006. Financial Times.com.
- Ypsilantis, B. *Upland Soil Erosion Monitoring and Assessment: An Overview*. Bureau of Land Management, Environmental Quality and Protection: Washington, DC, 2011.

APPENDIX A: CONTRACTOR INTERVIEW QUESTIONS

Questions:

1. What are the costs associated with and the time required for the implementation of each of the following erosion control measures?
 - a. hydroseeding per area
 - b. silt fencing per width of fence
 - c. green matting per area
 - d. gabions
 - e. culverts per length
 - f. shotcrete per area
 - g. grass seeding per area
 - h. sedimentation basins per area
2. What factors do you believe affect the rate of erosion?
3. Which erosion control method is the most effective at mitigating soil erosion?
4. Which erosion control do you think is the least effective at mitigating soil erosion?
5. How much soil will a segment of silt fencing accumulate per week?
6. What guidelines do you use in the installation and maintenance of each erosion control method?
7. What are the appropriate slope and compaction levels for hydroseeding to be effective?
8. Where have landslides occurred in the Pacific excavation work sites?
9. How severe have these land slippages been and have they occurred in areas where temporary or permanent measures have been implemented?
10. What is the maintenance schedule of each erosion control measure mentioned above?
11. How much man power is required for each maintenance schedule and how are they held accountable?
12. How do you measure the effectiveness of each control method?
13. What factors do you look at when deciding which erosion control methods are applicable for the different site conditions?
14. What will be the long term control methods in the areas currently using temporary methods?

APPENDIX B: RUSLE CALCULATIONS

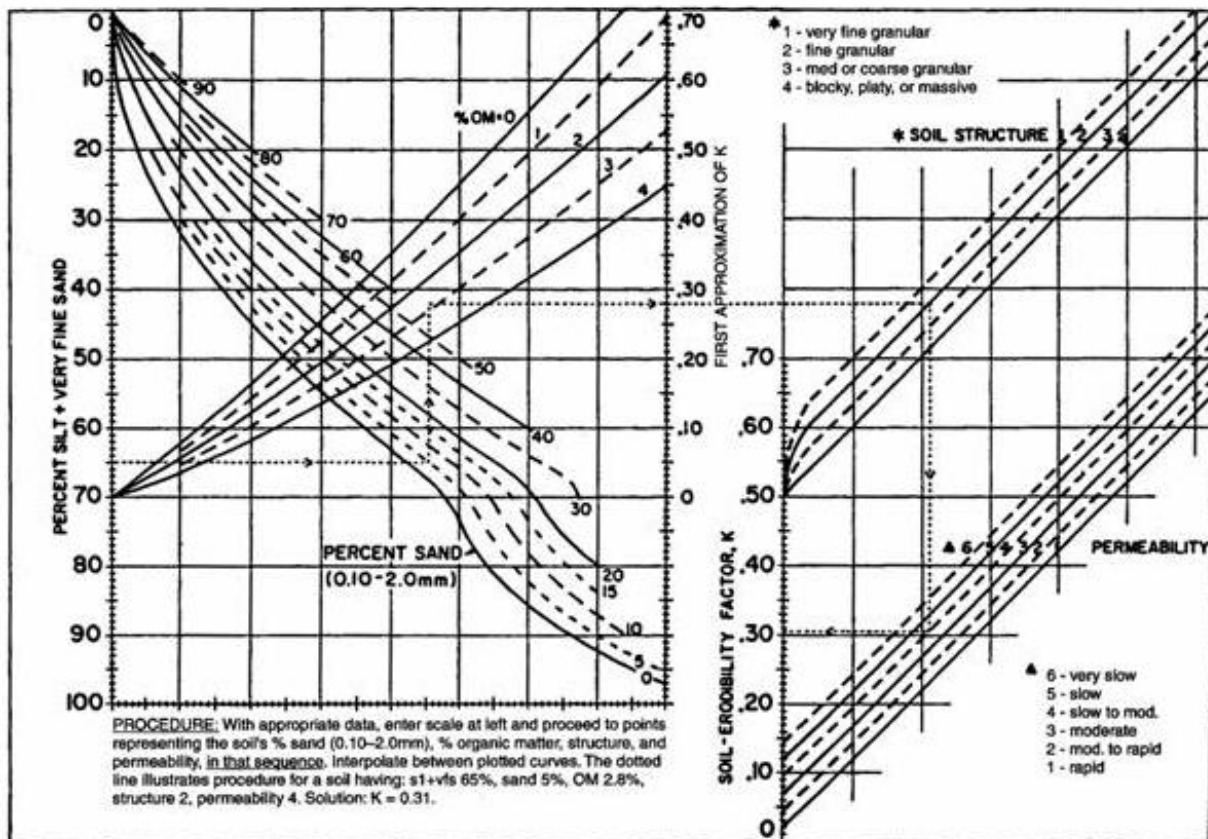

Figure B-1 K Value Graphical Calculator

Sample RUSLE Calculations

Sample Rain Intensity

Length of Time	Rainfall(mm)	Rainfall(in)
1 hr	11	0.433071

$$I = \frac{\text{Rainfall Depth}}{\text{Length of Time Raining}}$$

$$I = \frac{0.433071 \text{ in}}{1 \text{ hr}}$$

$$I = 0.433071 \frac{\text{in}}{\text{hr}}$$

Sample Rain Energy

$$E = 1099[1 - 0.72 * \exp(-1.72 * I)], \frac{\text{foot tons}}{\text{acre}} \text{ per inch of rain}$$

$$E = 1099[1 - 0.72 * \exp(-1.72 * 0.433071)], \frac{\text{foot tons}}{\text{acre}} \text{ per inch of rain}$$

$$E = 94.2506, \frac{\text{foot tons}}{\text{acre}} \text{ per inch of rain}$$

R Factor

Calculation with numbers for E and I for one rain event. After the summation the values present represent the total for all rain events. The R factor present is that for all storms over the three weeks of observation.

$$R = \frac{1}{n} \sum_{k=1}^m (E) * (I)$$

$$R = \frac{1}{3 \text{ weeks}} \sum_{k=1}^m \left(94.2506 \frac{\text{foot tons}}{\text{acre}} \text{ per inch of rain} \right) * \left(0.433071 \frac{\text{in}}{\text{hr}} \right)$$

$$R = \frac{1}{3} * (734.543)$$

$$R = 244.848$$

K Factor Sample Calculation for Site 1



Figure B-2 Soil composition at site 1

GPS Locations of Boreholes	Soil Type	% Sand	% OM	% Silt	Structure	Permeability
998066.810 N 650124.855 E 48.707 (MSL)	Overburden: Clay, Silt, Sand, Boulders; Top of Weathered Rock: Shale (Cucaracha Formation)	30	1	50	3	4

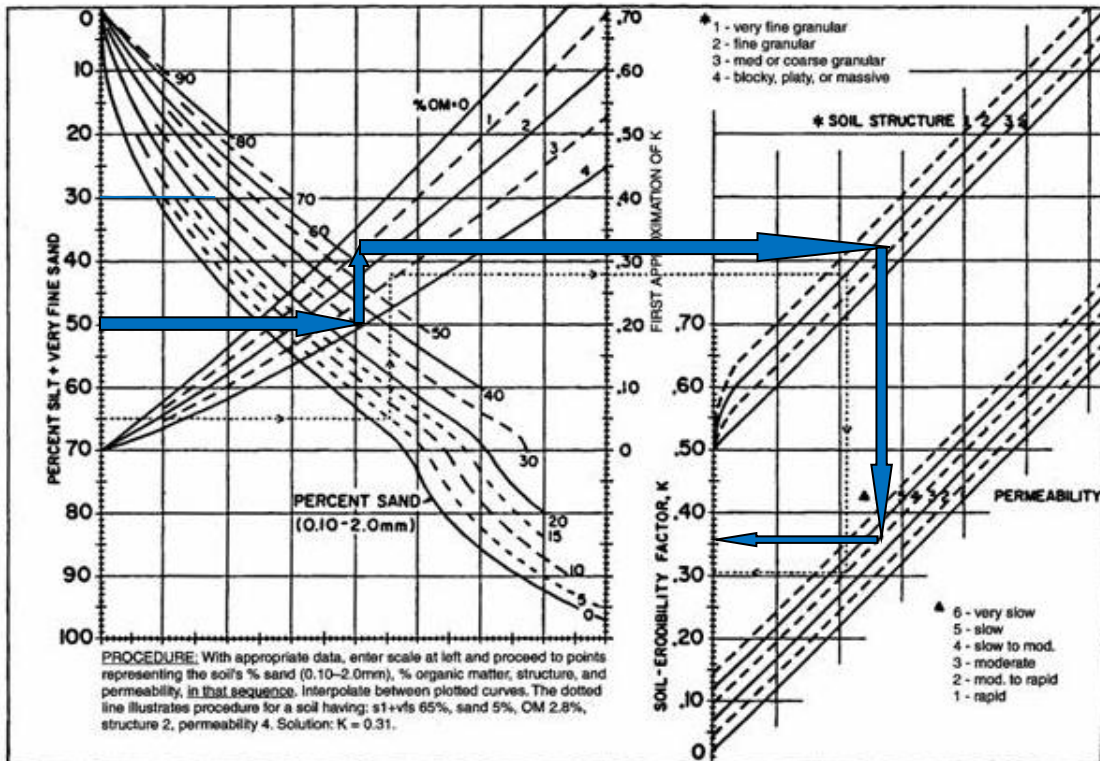

Through the use of the graphs the K value can be determined. First by locating the silt percent content on the far left of the graphs then draw a line to the appropriate sand percentage of the soil. From the soil percentage draw a line to the organic matter percent in the soil. Then draw a line from the percent organic matter to the appropriate soil structure as is described in the graph. Next draw a line from the structure to the appropriate permeability value as described in the graph then draw a line from the permeability level to the left on the axis where the K values are present. For site 1 the estimated percentages and other values are presented in the Table above. The resulting K factor is 0.35.

LS Factor Sample Calculation for Site 1

Height measurement	Length measurement	Slope Length	Constant	NN
96.75 in	171 inch	25	72.5	0.5

$$\text{Slope Steepness} = \frac{\text{Height}}{\text{Length}} * 100$$

$$\text{Slope Steepness} = \frac{96.75}{171} * 100$$

$$\text{Slope Steepness} = 56.58\%$$

$$LS = [0.065 + 0.0456 * (\text{slope steepness}) + 0.006541 * (\text{slope steepness})^2]x \left(\frac{\text{Slope Length}}{\text{Constant}} \right)^{NN}$$

$$LS = [0.065 + 0.0456 * (56.58) + 0.006541 * (56.58)^2]x \left(\frac{25}{72.5} \right)^{0.5}$$

$$LS = 11.44$$

C Factor Sample Calculation for Site 1

By making observations from the image below we can see that there is no real ground cover in relation to vegetation however. About 20% of the ground is cover by rocks and other debris. From this data we can look at the table below and look at the mechanically prepared sites and then over to 20% and see that the C factor for this location is 0.44.



	Percent cover ¹	Plant type	Percentage of surface covered by residue in contact with the soil:					
			0 %	20	40	60	80	95+
C factor for grass, grasslike plants, or decaying compacted plant litter.	0	Grass	0.45	0.20	0.10	0.042	0.013	0.003
C factor for broadleaf herbaceous plants (including most weeds with little lateral root networks), or undecayed residues.	0	Weeds	0.45	0.24	0.15	0.091	0.043	0.011
Tall weeds or short brush with average drop height ² of ≥20 inches	25	Grass	0.36	0.17	0.09	0.038	0.013	0.003
		Weeds	0.36	0.20	0.13	0.083	0.041	0.011
	50	Grass	0.26	0.13	0.07	0.035	0.012	0.003
		Weeds	0.26	0.16	0.11	0.076	0.039	0.011
	75	Grass	0.17	0.10	0.06	0.032	0.011	0.003
		Weeds	0.17	0.12	0.09	0.068	0.038	0.011
Mechanically prepared sites, with no live vegetation and no topsoil, and no litter mixed in.	0	None	0.94	0.44	0.30	0.20	0.10	Not given

P Factor Calculation

As described in the methodology chapter it is seen that the P value is 1.

Total Average Soil Loss for Site 1

$$A = R * K * LS * C * P$$

$$A = 244.848 * 0.35 * 0.44 * 1$$

$$A = 431.3634 \frac{\text{tons}}{\text{acre year}}$$

APPENDIX C: GIS MAP OF SOIL TYPES

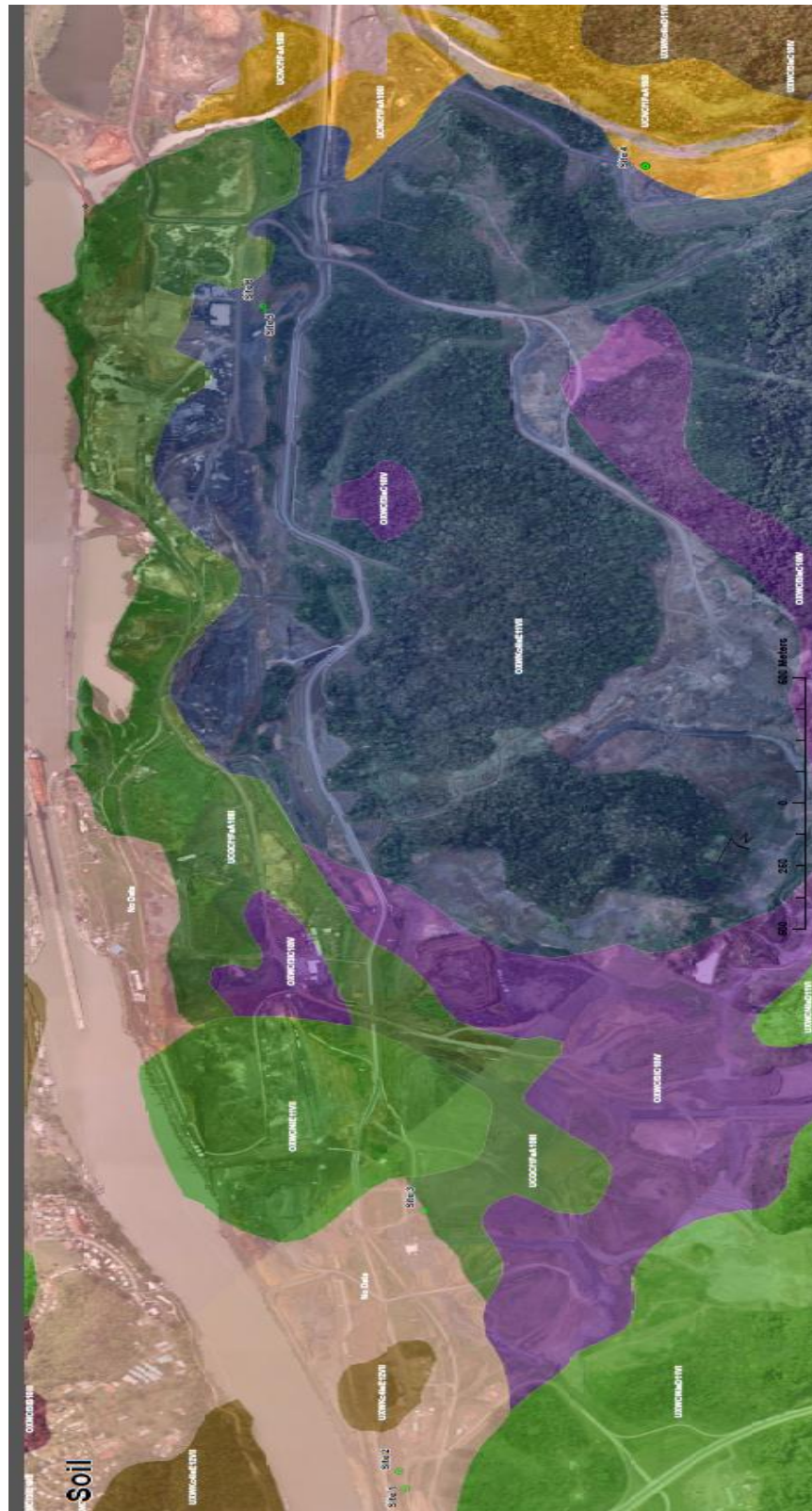

APPENDIX D: SLOPE CALCULATIONS

Equations used:

$$\text{Percentage Slope} = \frac{\text{Height}}{\text{Distance}} * 100$$

$$\text{Slope Angle (degrees)} = \tan^{-1} \frac{\text{Height}}{\text{Distance}}$$

Table D-1 - Calculated Results for Slope Measurements

Sites	Height	Distance	Radians	Degrees	Percentage
1	96.75	171	0.51	29.5	56.6
2	56.13	182	0.3	17.14	30.8
3	79	182	0.41	23.46	43.4
4	36	68	0.49	27.9	52.9
5	54	183.5	0.29	16.4	29.4
6	51.5	183.5	0.27	15.68	28.1

APPENDIX E: ACP SOIL CORE LOGS

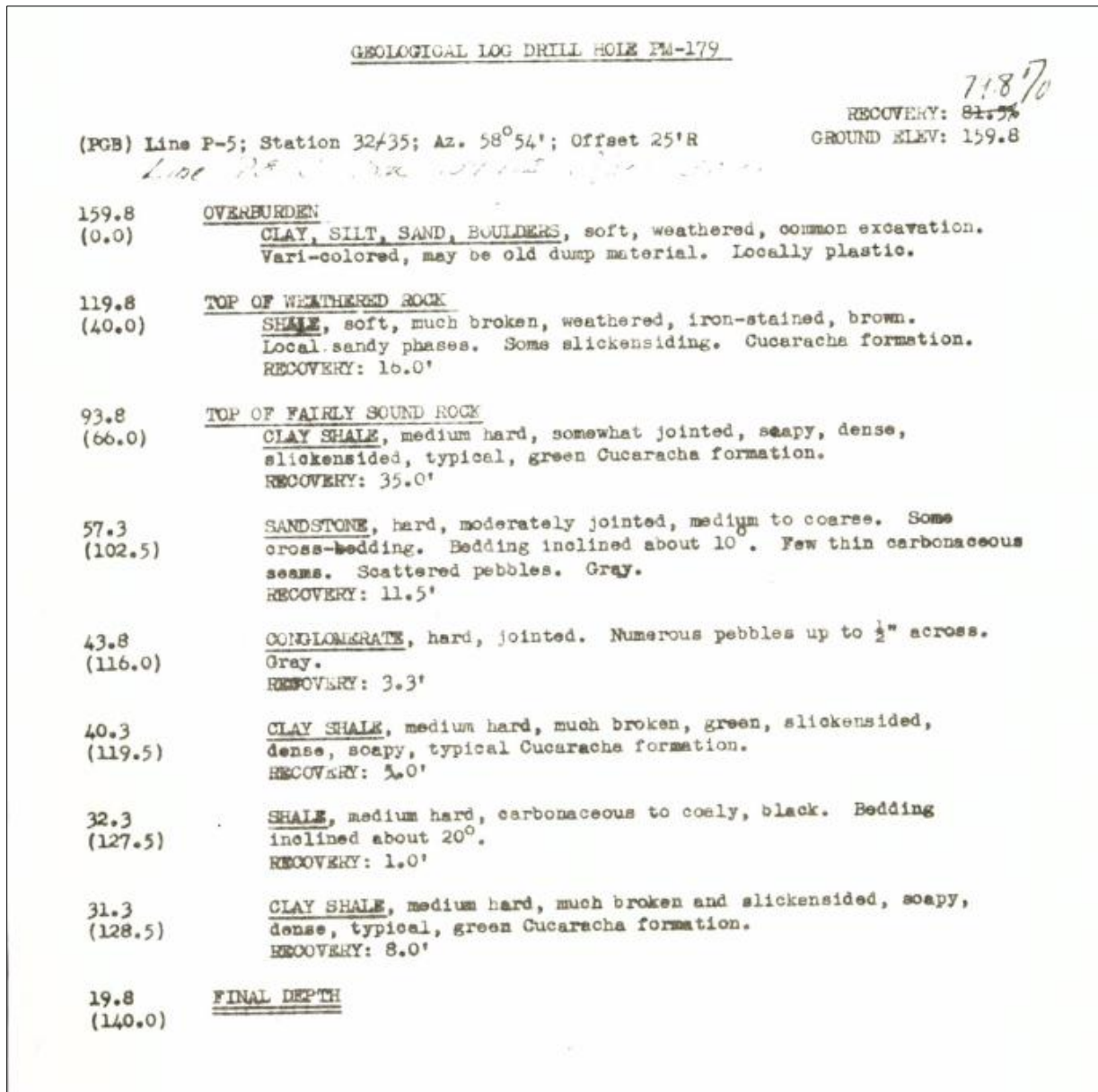

Figure E-1 - Soil Core Log for Sites 5 & 6

GEOLOGICAL LOG DRILL HOLE M-176

8°59'45809
(MWF) Location 79°36'42758

45.5%
RECOVERY: 47.9%
GROUND ELKV: 142.3

142.3 OVERBURDEN
(0.0) CLAY, silty, soft, plastic, brown, common excavation.
RECOVERY: 1.0'

141.3
(1.0) CLAY & PEBBLES, soft, unconsolidated. Angular weathered
to fresh basalt pebbles up to 3" across.
RECOVERY: 2.5'

133.3
(9.0) No core in box.

127.3
(15.0) TOP OF SOUND ROCK (?) (May be higher, no core from 9 to 15')
BASALT, hard, somewhat broken, fine-grained, rather fresh,
gray-black. A little iron-stain along joints near top.
RECOVERY: 6.0'

114.1 FINAL DEPTH
(28.2)

Classified by A.E. Sandberg, 11-22-40
Typed by M. Curren, 12-4-40
Checked by: *WCH* 12-4-40

Figure E-2 - Soil Core Log for Site 1

**PANAMA CANAL COMMISSION
ENGINEERING AND CONSTRUCTION BUREAU
GEOLOGICAL FIELD LOG**

BORING ESTUS-3

PROJECT: ESCOBAR PROPOSED NEW TIE UP STATION

PAGE 1 OF 20

LOCATION: WEST CUCARACHA REACH

NORTHING: 998050.455

EASTING: 650293.43

GROUND ELEVATION: 32.20 m

STATION: 61 km+851.43

OFFSET: 166.5 m W

TOTAL DEPTH: 41.00 m

CORE RECOVERY: 30.12 m

COMPLET. DATE: 22 Sept. 1998

INCLINATION: Vertical

START DATE: 14 Sept. 1998

LOGGERS: A. Diaz

DRILLER: J. Barahona

GEOLOGIST: P. Franceschi And A. Diaz

SOIL SYMBOLS, SAMPLERS, FIELD TEST DATA AND CORE RUN	ELEVATION	DEPTH	DESCRIPTION OF MATERIAL	DISCONTINUITY	DRILLING CHARACTERISTICS	POINT LOAD INDEX kPa	CORE RECOV (%)	RQD (%)
	(meters)							
	0	0.00	0.00 m OVERBURDEN, material inferred from cuttings, color of water and outcrop in bench. No attempt to recover core was made.		Drilled with tricone rotary bit to 3.00 m depth, no attempt to recover core was made.			
	32.11	0.13						
	31.98	0.26						
	31.85	0.39						
	31.72	0.52						
	31.59	0.65						
	31.46	0.78						
	31.33	0.91						
	31.2	1.04						
	31.07	1.17						
	30.94	1.3						
	30.81	1.43						
	30.68	1.56						

Figure E-3 - Partial Soil Core Log for Site 2

PANAMA CANAL AUTHORITY
ENGINEERING AND INDUSTRIAL SERVICES DEPARTMENT
GEOLOGICAL FIELD LOG

BORING PAC-48

PROJECT: PACIFIC APPROACH CHANNEL - THIRD LOCKS PROJECT

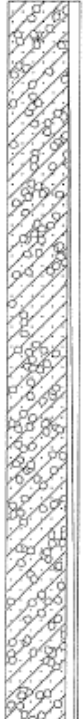
PAGE 1 OF 21

LOCATION: THIRD SET OF LOCKS - PARAISO REACH - WEST BANK

NORTHING: 997182.45 m
STATION: 62 K + 980.555 m
CORE RECOVERY: 94 %
START DATE: 28/July/2005
GEOLOGIST: Derek Irving
CHECKED BY: Pastora Franceschi S.

EASTING: 651165.112 m
OFFSET: 531.816 w
COMPLET. DATE: 01/August/2005

GROUND ELEVATION: 75.10 m
TOTAL DEPTH: 77.00 m
INCLINATION: Vertical
LOGGER: Derek Irving
DRILLER: Bacly Fundaciones, S.A.

SOIL SYMBOLS, SAMPLERS, FIELD TEST DATA AND CORE RUN	ELEVATION	DEPTH	DESCRIPTION OF MATERIAL	DISCONTINUITY	DRILLING CHARACTERISTICS	qu MPa	CORE RECOV (%)	RQD (%)
	(meters)							
	75.04	0	0.00 m FILL, RH-4, hard rock, strong, consists of fine-grained Basalt fragments, up to 10 cm in diameter, material dumped here to prepare drill site. Color: gray.		Drilled with PQ double tube, diamond bit and water. Wireline system.			
	74.79	0.25						
	74.53	0.51	C.R.=33%				33%	
	74.27	0.77	0.90 m - TOP OF PEDRO MIGUEL FORMATION OVERBURDEN, OC-3, medium consistency, moderate plasticity, moderate dry strength, low water content, consists of silt, some clay and sand, seems to be residual, saprolitic soil, derived from Agglomerate of the Pedro Miguel Formation, by normal weathering process. Color: light brown.		Drilled with PQ double tube, diamond bit and water. Wireline system.			
	74.02	1.03						
	73.76	1.28						
	73.5	1.54						
	73.24	1.8	C.R.=73%				73%	
	72.99	2.06	2.00 m - TOP OF WEATHERED ROCK AGGLOMERATE, Tuffaceous, highly weathered, OC-5 to RH-1, very high consistency overburden to very soft rock, weak, broken into small pieces, up to 5 cm in diameter, much of the rock is converted to soil, contains many dark oxides. Color: brown.		Drilled with PQ double tube, diamond bit and water. Wireline system.			
	72.73	2.31						
72.47	2.57							
72.22	2.83	C.R.=79%				100%		

Figure E-4 - Partial Soil Core Log for Site 3

THE PANAMA CANAL
SPECIAL ENGINEERING DIVISION
GEOLOGY SECTION
(Geological Studies Under Public Law 280)

GEOLOGICAL LOG DRILL HOLE No. 3C-106

Letter: 3C-EP Classified by: D. W. Fawcett & M. J. Gleason Date: October 8, 1947
 Existing
 Line: Canal Center Line True Station: 2214+16 Offset: 5601' B- Gr. ~~XXXXXX~~ Elev.: +147.3
 Reach: Miraflores Canal Station: ~~2046+00~~ Offset: 5601' B- Recovery: 98%
 Latitude: 8°59'15.72" Longitude: 79°36'12.68" Driller: P. N. Tucker

- +147.3 OVERBURDEN
 (0.0) CLAY, medium soft to medium hard (OH-2 to OH-3); dense; slightly sandy in upper portion becoming more sandy towards base; contains scattered pebble- to boulder-size fragments of RH-3 basalt; medium plastic; weak to medium tough; slight to medium dry strength; yellow brown to reddish brown.
- +134.3 TOP OF WEATHERED ROCK
 (13.0) BASALT, RH-2 to RH-3 pebble- to boulder-size fragments of basalt in OH-2 to OH-4, variably clayey to sandy, nonplastic to medium plastic, weak to medium tough matrix; original fine-grained texture evident in matrix material; gray, yellow gray and reddish gray. Recovery 21.0'.
- +85.4
 (61.9) CLAY, medium soft to medium hard (OH-2 to OH-3); dense; slightly sandy; trace to medium plastic; firm to medium tough; medium dry strength; purplish gray. Recovery 1.5'.
- +82.3
 (65.0) CLAY, medium hard to hard (OH-3 to OH-4); dense; variably sandy; slightly brittle; contains scattered pebble- to cobble-size fragments of slightly weathered basalt; medium plastic; firm to medium tough; slight to medium dry strength; brick red. Recovery 3.0'.
- +77.5 TOP OF SOUND ROCK (Base of Common Excavation)
 (69.9) BASALT, very hard (RH-4); close, high-angle jointing; variably opened or cemented with calcite in upper portion and quartz in basal portion; fine grained; slightly porphyritic; altered; reddish gray; unit is strong; core recovered in fragments to 1.5' lengths. Recovery 16.3' (99%).

Figure E-5 - Soil Core Log for Site 4

APPENDIX F: RUSLE DATA

Table F-1 - LS Factor Data

Sites	Point 1	Point 2	Height	Distance	Degrees	% Steepness	Slope Length(m)	LS
1	998005.14 m N 650118.47 m E 80.43m HAE	998006.94 m N 650126.68 m E 91.64m HAE	96.75	171	29.5	0.5658	7.62	11.43856
2	998035.31 m N 650146.29 m E 80.55m HAE	998024.14 m N 650135.17 m E 89.00m HAE	56.13	182	17.14	0.3084	15.5448	6.200364
3	997013.37 m N 650873.10 m E 97.46m HAE	997008.02 m N 650864.77 m E 101.02m HAE	79	182	23.46	0.4341	9.144	8.563503
4	993569.55 m N 652902.10 m E 79.56m HAE	993588.50 m N 652882.46 m E 92.02m HAE	36	68	27.9	0.5294	27.7368	18.43095
5	994723.19 m N 653406.07 m E 77.69m HAE	994724.74 m N 653423.12 m E 91.07m HAE	54	183.5	16.4	0.2943	16.764	6.024204
6	994720.01 m N 653428.89 m E 101.49m HAE	994726.74 m N 653440.69 m E 96.84m HAE	51.5	183.5	15.68	0.2807	14.3256	5.025617

Table F-2 -K and C Values Data

GPS Locations of Boreholes	Soil Type	% Sand	% OM	% Silt	Structure	Permeability	K Value	C Value
998066.810 N 650124.855 E 48.707 (MSL)	Overburden: Clay, Silt, Sand, Boulders; Top of Weathered Rock: Shale (Cucaracha Formation)	30	1	50	3	4	0.35	0.44
998050.5 N 650293.4 E 32.2 (HAE)	Overburden: Pedro Miguel Formation (abundant pebbles, cobbles and boulders up to 90 mm in dia; mixed with clay, silt and sand ; Top of Weathered Rock: Clay Shale (Cucaracha Formation)	30	1	50	3	4	0.35	0.003
997182.450 N 651165.112 E 75.104 (MSL)	Fill: hard rock, strong, consists of fine-grained Basalt fragments, up to 10 cm in diameter; Overburden: Pedro Miguel Formation Top of Weathered Rock: Agglomerate Tuffaceous, highly weathered;	50	0	20	4	2	0.2	0.03
993429.20 N 653373.50 E	Overburden: Clay, medium soft to medium hard; slighty sandy in upper portion; scattered pebbles and boulder - size fragments of basalt; Top of Weathered Rock: Basalt/Clay;	40	1	40	3	3	0.33	0.2
994720.4 N 653347.2 E 43.37 (HAE)	Overburden: Clay; Clay and basalt pebbles (up to 3" in dia); Top of Weathered Rock: Basalt;	30	1	40	2	5	0.22	0.002

994720.4 N 653347.2 E 43.37 (HAE)	Overburden: Clay; Clay and basalt pebbles (up to 3" in dia); Top of Weathered Rock: Basalt;	10	1	20	1	6	0.05	0.1
---	--	----	---	----	---	---	------	-----

APPENDIX G: STATISTICAL ANALYSIS

Table G-1- Confidence Interval (SPSS Software)

Descriptives

Rating

	N	Mean	Std. Deviation	Std. Error	95% Confidence Interval for Mean		Minimum	Maximum
					Lower Bound	Upper Bound		
Control	6	101.8333	60.40999	24.66227	38.4369	165.2297	31.00	189.00
bmp1	6	103.8333	35.49319	14.49003	66.5855	141.0812	52.00	159.00
bmp2	6	27.8333	9.26103	3.78080	18.1145	37.5522	18.00	45.00
bmp3	6	67.1667	19.09363	7.79494	47.1291	87.2042	45.00	90.00
bmp5	6	66.0000	17.81011	7.27095	47.3094	84.6906	48.00	96.00
Total	30	73.3333	42.26789	7.71703	57.5502	89.1164	18.00	189.00

Table G-2 - Test of Homogeneity of Variances

Rating

Levene Statistic	df1	df2	Sig.
5.025	4	25	.004

Table G-3 - ANOVA Analysis

Rating

	Sum of Squares	df	Mean Square	F	Sig.
Between Groups	23427.333	4	5856.833	5.159	.004
Within Groups	28383.333	25	1135.333		
Total	51810.667	29			

Table G-4 - Post-Hoc Tests

Multiple Comparisons							
Dependent Variable: Rating							
	(I) BMPs	(J) BMPs	Mean Difference (I-J)	Std. Error	Sig.	95% Confidence Interval	
						Lower Bound	Upper Bound
Tukey HSD	Control	bmp1	-2.00000	19.45365	1.000	-59.1329	55.1329
		bmp2	74.00000*	19.45365	.007	16.8671	131.1329
		bmp3	34.66667	19.45365	.406	-22.4662	91.7995
		bmp5	35.83333	19.45365	.373	-21.2995	92.9662
	bmp1	Control	2.00000	19.45365	1.000	-55.1329	59.1329
		bmp2	76.00000*	19.45365	.005	18.8671	133.1329
		bmp3	36.66667	19.45365	.351	-20.4662	93.7995
		bmp5	37.83333	19.45365	.321	-19.2995	94.9662
	bmp2	Control	-74.00000*	19.45365	.007	-131.1329	-16.8671
		bmp1	-76.00000*	19.45365	.005	-133.1329	-18.8671
		bmp3	-39.33333	19.45365	.285	-96.4662	17.7995
		bmp5	-38.16667	19.45365	.313	-95.2995	18.9662
	bmp3	Control	-34.66667	19.45365	.406	-91.7995	22.4662
		bmp1	-36.66667	19.45365	.351	-93.7995	20.4662
		bmp2	39.33333	19.45365	.285	-17.7995	96.4662
		bmp5	1.16667	19.45365	1.000	-55.9662	58.2995
	bmp5	Control	-35.83333	19.45365	.373	-92.9662	21.2995
		bmp1	-37.83333	19.45365	.321	-94.9662	19.2995
		bmp2	38.16667	19.45365	.313	-18.9662	95.2995
		bmp3	-1.16667	19.45365	1.000	-58.2995	55.9662

*. The mean difference is significant at the 0.05 level.

Table G-5 - Homogenous Subsets

Rating				
	BMPs	N	Subset for alpha = 0.05	
			1	2
Student-Newman-Keuls ^a	bmp2	6	27.8333	
	bmp5	6	66.0000	66.0000
	bmp3	6	67.1667	67.1667
	Control	6		101.8333
	bmp1	6		103.8333
	Sig.			.128
Tukey HSD ^a	bmp2	6	27.8333	
	bmp5	6	66.0000	66.0000
	bmp3	6	67.1667	67.1667
	Control	6		101.8333
	bmp1	6		103.8333
	Sig.			.285
Means for groups in homogeneous subsets are displayed.				
a. Uses Harmonic Mean Sample Size = 6.000.				

Table G-6 - Means Plot

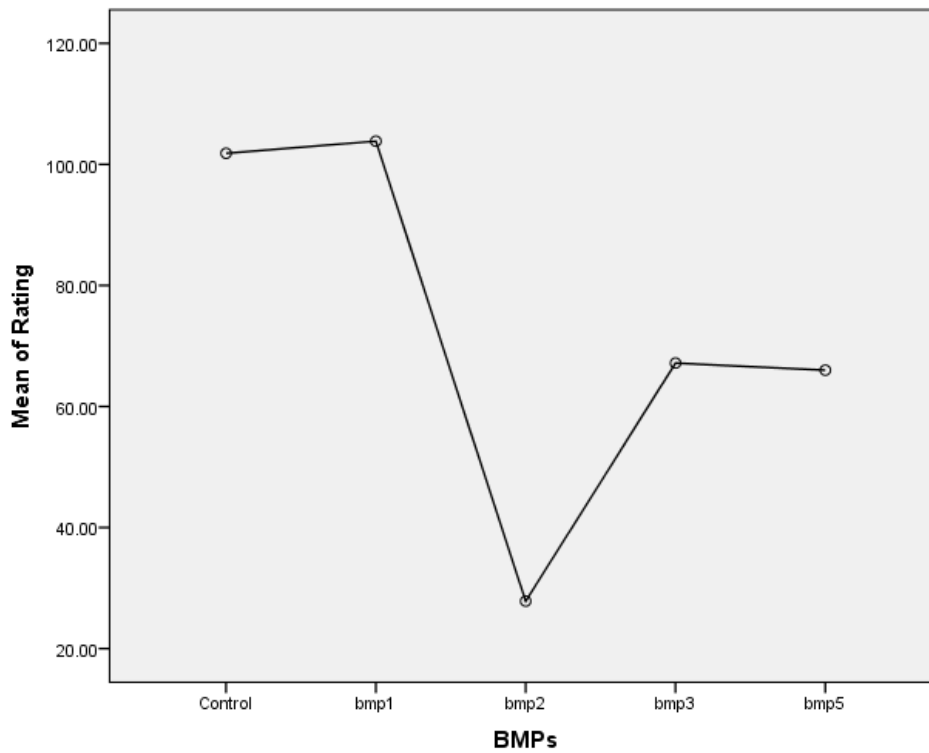

APPENDIX H: BLASTING DATA

Table H-1 - Distance Analysis for Blasting

Sites	Average Distance from Blasting (m)	PAC	Blasting Occurrences: Week 1: Nov 14-20	Blasting Occurrences: Week 2: Nov 21-27
1	1130	PAC 0	Mon, Nov. 14th: 1 (Max Ins. Charge: 322 kg) Tues, Nov. 15th: 1 (Max. Ins. Charge: 313 kg) Wed, Nov 16th: 2 (Max. Ins. Charge: 23 & 2 kg) Thurs, Nov 17th: 1 (Max. Ins. Charge: 22 kg) Sat, Nov 19th: 1 (Max. Ins. Charge: 1328 kg)	Mon, Nov 21st: 1 (Max. Ins. Charge: 123 kg) Tues, Nov 22nd: 1 (Max. Ins. Charge: 144 kg) Wed, Nov 23rd: 3 (Max. Ins. Charge: 90.59, 80 & 272 kg) Thurs, Nov 24th: 1 (Max. Ins. Charge: 15 kg)
2	1050	PAC 0		
3	520	PAC 0		
4	2120	PAC 4	Thurs, Nov 17th: 1 (Max. Ins. Charge: 6700 kg) Fri, Nov 18th: 1 (Max. Ins. Charge: 6100 kg) Sat, Nov 19th: 1 (Max. Ins. Charge: 16300 kg)	Mon, Nov 21st: 1 (Max. Ins. Charge: 5145 kg) Wed, Nov 23rd: 1 (Max. Ins. Charge: 10700 kg) Thurs, Nov 24th: 1 (Max. Ins. Charge: 16300 kg)
5	1150	PAC 4		
6	1150	PAC 4		

Table H-2 - Seismographic data from monitoring stations

Distances of stations from blasting (m)	MIC (lbs/delay)	MIC (kg/delay)	Scaled distance	PPV - Long (m/s)	PPV - Tran (m/s)	PPV - Vert (m/s)
573	233.7	106.0	37.5	0.005	0.004	0.003
274	222.7	101.0	18.4	0.006	0.005	0.005
377	233.7	106.0	24.7	0.007	0.007	0.005
441	147.7	67.0	36.3	0.001	0.001	0.000
323	134.2	60.9	27.9	0.002	0.002	0.002
287	359.4	163.0	15.1	0.005	0.005	0.005
400	340.0	154.2	21.7	0.004	0.004	0.006
287	359.4	163.0	15.1	0.004	0.006	0.003
298	359.4	163.0	15.7	0.003	0.003	0.001
173	584.5	265.1	7.2	0.007	0.006	0.007
345	264.5	120.0	21.2	0.004	0.003	0.005
449	271.8	123.3	27.3	0.004	0.007	0.011
222	123.0	55.8	20.1	0.007	0.005	0.006

Examples of Seismographic Reports



FFT Report

Date/Time Long at 12:36:15 December 1, 2011
Trigger Source Geo: 0.0213 in/s, Mic: 0.0109 psi(L)
Range Geo : 5.00 in/s
Record Time 4.0 sec at 1024 sps

Serial Number 5682 V 2.61 MiniMate
Battery Level 6.3 Volts
Unit Calibration April 29, 2010 by Instantel
File Name G682E1QJ.0F0

Notes
Location: Reach MIR- Aprox Etesa Torre 37
Client: Division de Proyectos-IAEP
User Name: Unidad de Geodesia-IAIT
Converted: December 1, 2011 13:54:59 (V10.06)

Extended Notes
Voladura Terrestre CAP-4 463 Etesa 37
Pos. de Voladura: N0995260 E0653378
Pos. de Sismografo: N0995435 E065 2706
Dist.: 573.0m Lbs/Delay: 233.73

Post Event Notes

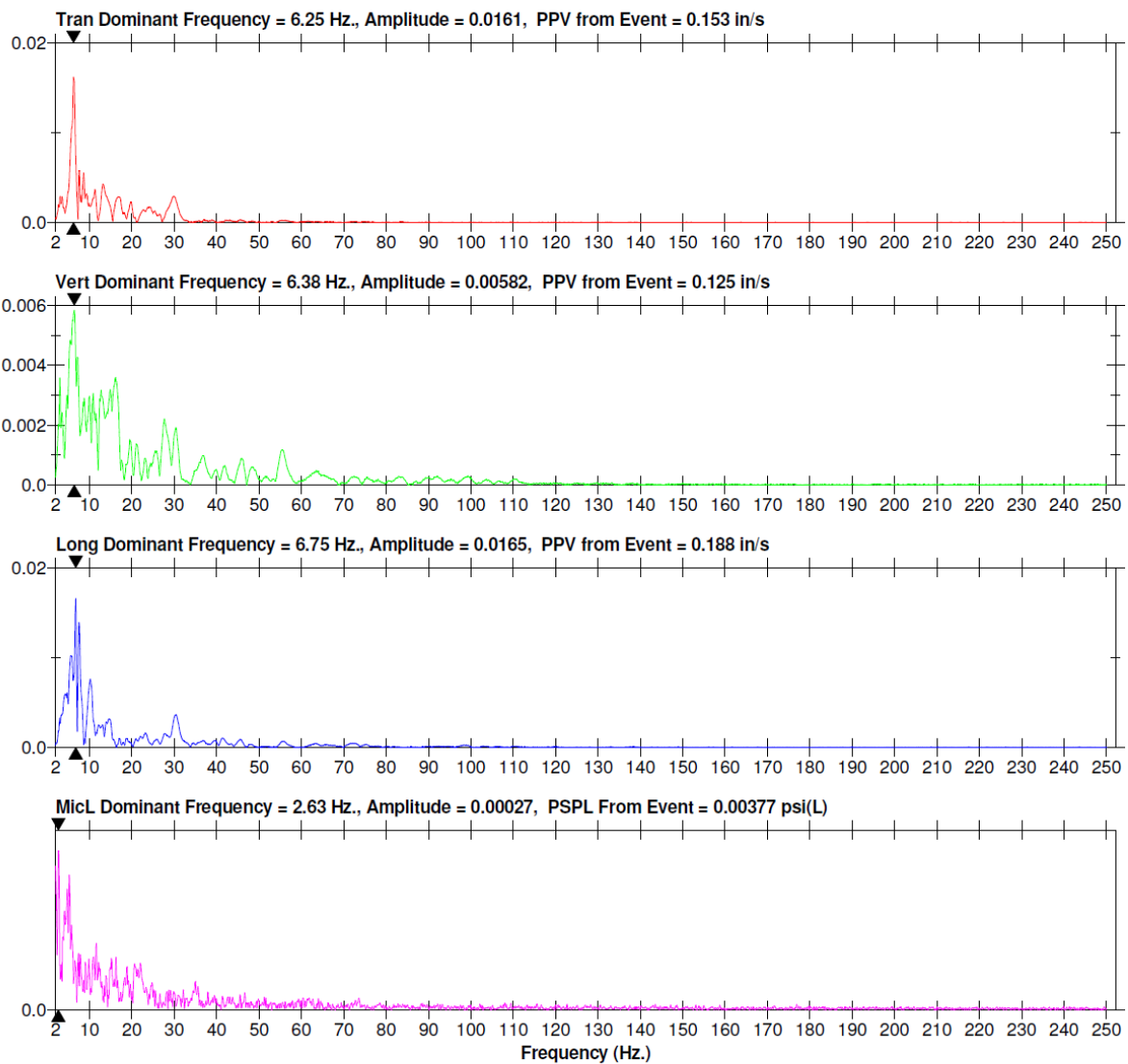

Date/Time Vert at 12:02:42 November 14, 2011
Trigger Source Geo: 0.0213 in/s, Mic: 0.00972 psi(L)
Range Geo : 5.00 in/s
Record Time 4.0 sec at 1024 sps

Serial Number 5682 V 2.61 MiniMate
Battery Level 6.4 Volts
Unit Calibration April 29, 2010 by InstanTEL
File Name G682E0V0.410

Notes
 Location: Reach Miraflores Lake-Carretera Borinque
 Client: Division de Proyectos-IAEP
 User Name: Unidad de Geodesia-IAIT
 Converted: November 15, 2011 06:31:32 (V10.06)

Extended Notes
 Voladura Terrestre CAP-4-452
 Pos. de Voladura: N0995282 E0653213
 Pos. de Sismografo: N0995214 E0652948
 Dist.: 274.0 m Lbs/Delay:222.7

Post Event Notes

