

March 2015

# Clock Tower MQP

Andrew James Tanner  
*Worcester Polytechnic Institute*

Follow this and additional works at: <https://digitalcommons.wpi.edu/mqp-all>

---

## Repository Citation

Tanner, A. J. (2015). *Clock Tower MQP*. Retrieved from <https://digitalcommons.wpi.edu/mqp-all/3449>

This Unrestricted is brought to you for free and open access by the Major Qualifying Projects at Digital WPI. It has been accepted for inclusion in Major Qualifying Projects (All Years) by an authorized administrator of Digital WPI. For more information, please contact [digitalwpi@wpi.edu](mailto:digitalwpi@wpi.edu).



# **Worcester Memorial Clock Tower MQP: Project Management and Alternative Design**

A Major Qualifying Project

Submitted to the faculty of  
WORCESTER POLYTECHNIC INSTITUTE  
In partial fulfillment of the requirements for the  
Degree of Bachelor of Science

Submitted on:  
March 25, 2015

Submitted by:  
Kelly Kalbacher  
Andres Pedraza Rayo  
Andrew Tanner

Submitted to:  
Project Advisor: Guillermo F. Salazar  
Project Advisor: Nima Rahbar

## Abstract

This project explores an alternative structural design for the Worcester Memorial Clock Tower currently being built at Worcester Psychiatric Hospital in memory of the Worcester Insane Hospital. It is proposed to support the tower using a steel frame and builds the tower envelope with precast tilt-up reinforced concrete panels and embedded stone veneer attached to the steel. A cost estimate and construction schedule for the alternative design is prepared and compared to the existing design.

## Authorship

The sections of this Major Qualifying Project were contributed equally by all three partners. The following chapters were written by the specified person or persons:

Capstone Design – Kelly

Professional License Statement – Andrew

Introduction – Andres

Background – Kelly, Andres and Andrew

Alternative Design – Kelly and Andrew

Alternative Cost and Schedule – Andres

Conclusion – Kelly, Andres and Andrew

## Capstone Design Experience Statement

This Major Qualifying Project meets the requirement for the capstone design experience by proposing an alternative structural design to the actual construction of the Worcester Memorial Clock Tower currently being built at Worcester Massachusetts. The proposed design supports the tower using a steel frame and builds the tower envelope with precast tilt up reinforced concrete panels and embedded stone veneer attached to the steel. A cost estimate and construction schedule for the alternative design is prepared and compared to the existing design that uses a cast-in-place reinforced concrete structural frame with traditional stone veneer masonry work. The benefits of using this alternative steel design not only stops at cost efficiency and timeliness, but also provides a larger working area within the structure. This allows for workers to easily maneuver within the structure when maintenance is required.

This alternative design was achieved through researching constructions types and methods along with multiple load calculations to ensure structural integrity. Once the steel structure design was chosen a Revit Structural Model was created using the structural components designed for, after using hand calculations to determine the steel dimensions required. This Structural Model was then imported to Robot for further analysis of the structural design. Hand calculation and a basic experiment was then performed for the reinforced concrete panels that will be holding the Ashlar Stones. Once the steel framing and reinforced concrete panels was designed for the Clock Tower all of these components were involved in the cost estimating of the total project using unit cost from RSMeans. Along with the cost estimations of the total project a construction schedule was created using Primavera Software.

Design constraints including constructability, sustainability, economics, and ethical and safety concerns were addressed in this study. These considerations allowed for a better understanding of an engineering project from various aspects.

Constructability was taken into consideration when choosing the alternative design for the Clock Tower. It is an engineer's job to determine how the design will be constructed, what materials will be used, and how everything will connect together. This project proposes using a tilt-up-lift construction method in order for the stone veneer panels to be lifted and attached to the steel structure. The tilt-up-lift construction method is beneficial in multiple ways, it allows for the panels to be built on-site in a controlled environment and for a shorter construction period.

All projects have a limited budget and it is up to the engineer to look for best cost effectiveness for their design. The cost implications of using the proposed design required estimations of the cost and the construction time. This was done by using RS means, primavera

As an engineer you have a responsibility to the public and workers for your design to meet certain standards. Each project has a unique set of parameters and this project deals with a very dangerous set up. Since we are using a tilt-up design for the concrete panels to be attached to the structure some of these panels will be hoisted over 100 feet into the air. Much consideration and thought was needed to be put into this to ensure no worker onsite would be harmed in case any failure were to occur in raising these panels.

## Professional License Statement

Civil engineering is the second oldest engineering discipline after military engineering, and can be argued that it was the first engineering discipline for mankind. A professional licensed civil engineer deals with the design, construction, and maintenance of physical and nature built environment, examples of these are bridges, buildings, and roads. A professional license protects the public by regulating requirements to restrict practice to qualified individuals that have obtained a professional license. To receive the elite status of a P.E. (professional engineer) one must complete an undergraduate degree which provides them with industry-accredited qualifications. Following receiving a Bachelor's of science or engineering, the engineer must fulfill a range of requirements to their specified sub-discipline, typically 4 to 5 years of work experience and exam requirements before being certified. One must pass a Professional Engineering Exam which tests a person's ability to practice and demonstrate competently in a particular engineering discipline. Once certified as a professional engineer you are licensed to practice the discipline of civil engineering freely and may stamp construction documents with your licensed stamp if you desire a building, road, or bridge to be built.

The Worcester Memorial Clock tower MQP developed by our group has exposed us to the concept of designing and analyzing, as would any true professionally licensed civil engineer. This project explores an alternative structural design for the Worcester Memorial Clock Tower, currently being built at the Worcester Recovery Center and Hospital using cast-in-place reinforced concrete. The alternative design is a steel structured tower with tilt up reinforced concrete panels that are attached to the steel frame. These panels are designed to carry the heavy loads of the aesthetic stone preserved from the original structure built in 1877. Using the steel structure design and the stone panels, a new construction schedule and project cost estimation was made.

In professional engineering a civil engineer receives a proposed design from either an owner and/or an architect. The engineer then has to create the design so that it is not only safe to the public, in budget with the owner, and as well to the satisfaction to the owner and architect. At first it may seem easy but many alterations will be made throughout the process. The engineer will design the project, the architect and/or owner may not be satisfied with the price or how it may look, the design will change several times before all parties involved can come to an agreement. Another scenario in professional civil engineering is when an engineer receives a design from an owner and/or architect that was designed by another P.E. with a certain material (ex. Steel/Wood/Concrete) and they want to see if you can alternatively design it for cheaper or have it built faster with a different material (ex. Steel/Wood/Concrete). This scenario often happens when the original design turns out to be over the owners originally intended budget.

Our project is a good example of an alternative design. The current Worcester Memorial Clock tower in memory of the old hospital that was demolished is being rebuilt using CIP reinforced concrete with masonry veneer. The stones from level 6 and above have been preserved from the original structure and will have to be reattached exactly as they appeared before to make for the proper look. In our project we propose an alternative design to reinforced concrete and proposed steel be used to design the main structure of the tower with the use of reinforced concrete only for the tilt up panels attached to the steel structure. Typically concrete is a far cheaper material than steel, however our intent is to have the tower built at a much faster rate which will decrease the total amount of labor hours needed on the project. Decreasing the labor hours out the higher cost in materials needed for the alternative design. In our study we completed the design and erection of the tower 65 days before Gilbane is intending on finishing the tower saving 520 labor hours per worker. Hopefully building the tower faster and cheaper than Gilbane construction.



## Table of Contents

Abstract.....	ii
Authorship.....	iii
Capstone Design Statement.....	iv
Professional License Statement.....	vi
Table of Figures.....	x
1.0 Introduction.....	1
2.0 Background.....	4
2.1 History of the Worcester Insane Asylum.....	4
2.2 DCAMM.....	7
2.3 Costello Dismantling.....	7
2.4 Collaboration Award.....	10
2.5 Gilbane Construction.....	11
2.6 Ellenzweig.....	13
2.7 Construction Project Management.....	13
2.7.1 Filed Sub-Bid System.....	14
2.7.2 Construction Management.....	14
3.0 Alternative Design.....	15
3.1 Steel Structure Analysis.....	15
3.1.1 Steel member design.....	21
3.2 Concrete Panel Design.....	23
3.2.1 Tilt-Up-Lift.....	25
3.2.2 Panel Anchoring Systems.....	27
3.2.3 Flashings.....	28
4.0 Cost Estimates and Schedule.....	29
4.1 Project Management .....	29
4.2 Clock Tower Steel Process.....	30
4.3 Fabrication and Installation of Concrete Panels.....	31
4.4 Crane Logistics.....	32
4.5 Cost Estimates.....	34
4.6 Schedule.....	36
5.0 Conclusion.....	41
6.0 References.....	42

7.0 Appendices.....	43
A - Force Calculations.....	43
B - Floor Plans.....	46
C – Steel Calculations and Member Sizing.....	55
D –Mat Foundation Calculations.....	64
E – Reinforced Panel Calculations.....	67
F – Cost Estimates.....	71
G – Project Schedule.....	73
H – SAP Model.....	76
I – Detail Drawings.....	80
J – Site Plans.....	84
K – WBS Timeline.....	86
L – Activity Schedule.....	88
M – Activity List.....	90
N – Proposal.....	92
O – Electronic Files.....	110

## Table of Figures

Figure 1: Insane Hospital, Worcester, Mass. 1906 postcard.....	5
Figure 2: Map of New and Historical Buildings.....	6
Figure 3: Costello dismantling the Clock Tower.....	9
Figure 4: Dan Costello accepting Collaboration Award.....	11
Figure 5: Gilbane’s progress of Construction on the Tower.....	12
Figure 6: Tower Levels.....	16
Figure 7: Robot Tower Design.....	18
Figure 8: Steel Beam Design.....	19
Figure 9: Panel Shelf Design.....	19
Figure 10: Mat Foundation.....	20
Figure 11: Uniformly Distributed Load Equations.....	21
Figure 12: Fixed Support Design.....	22
Figure 13. Rebar placement in panel.....	24
Figure 14. Reinforcement concrete panel with stones and mortar.....	24
Figure 15: LR 1100 Crawler.....	27
Figure 16: 2-Man Basket Crane.....	33
Figure 17: Cost Estimates.....	35
Figure 18: Project Milestones.....	37
Figure 19: Project Submittals.....	38
Figure 20: WBS Code.....	39
Figure 21: Tower Waterproofing.....	40

## 1.0 Introduction

In 1833 the Worcester Insane Asylum was opened for the care of mentally ill patients. The centerpiece of the asylum was a massive clock tower that rose up from the administrative building. In the early 1990's the asylum was officially closed down and demolition on the site began. The administrative building which featured an exterior stone wall, was scheduled to be preserved with the famous clock tower. Unfortunately, in 1991 the building caught fire and after significant structural damage done on the building it was determined to be structurally deficient. The desire to preserve the building was outweighed by the need to prevent a dangerous collapse (Costello, 2013). It was decided the building would be dismantled and the tower would be rebuilt on the site in honor of the massive role Worcester played in the treatment of mental health over the past 180 years in the United States of America (McGovern 2012).

The major project participants of the rebuilding of the clock tower project are the owner, Division of Capital Asset Management and Maintenance (DCAMM), the architect, Ellenzweig from Cambridge MA, the construction manager, Gilbane Building Company from providence RI, and the dismantling company, Costello from West Wareham MA. The dismantling operation required the top of the tower to be taken apart piece by piece, documenting the identity and location of every stone in detail through photographing, and numerical codification so that the entire façade could be faithfully restored as a part of the new tower. With the tower being so high, with a height of 135 feet, the city of Worcester fire department was on standby for the dismantling ready to perform an aerial rescue at any moment. The demolition was completed in March of 2013 with no accidents. On October 31<sup>st</sup>, Costello Dismantling won the Collaboration Award at the 2013 World Demolition Awards for this project.

Gilbane Building Company is responsible for managing the construction of the new clock tower that is going to be replacing the famous one that stood for many years. Structures North was the engineering company to design the tower. The architectural firm, Ellenzweig provided programming, site analysis, and design of the new facility. The design was created to replicate the old tower with the same aesthetically pleasing stone masonry used in the 1830's. The engineers at Structures North designed the cast-in-place reinforced concrete that would support the tower. Since the old building only had the top of the tower rise out of it, Ellenzweig and Preservation Worcester worked together to come up with a similar look through the bottom part of the structure at the ground level allowing the tower to maintain the Victorian-Era look.

The goal of this study is to explore an alternative structural design for the tower and make a corresponding analysis of the construction schedule and cost estimates based on the provided schedule and initial cost figures calculated by Gilbane Building Company,

The current structural design is a tower made of reinforced concrete and the proposed alternative design uses a steel frame. Changing from reinforced concrete to a steel frame structure presents new challenges as to how the existing stone from the old clock tower is attached to the structure. A three-dimensional digital model of the proposed alternative steel design was developed using Robot where structural analysis will be performed on the structure to determine its performance and code compliance. Additional design work that will be needed for the attaching of the stone, or other individual member sizing will be performed by hand following American Institute of Steel Construction (AISC) code. From a project management standpoint the alternative design will be cost estimated and the construction method scheduled using Primavera Project Management software. The project will be compared to the original schedule and cost estimation of the Clock Tower.

With the alternative design of a steel structure Clock Tower and the attaching reinforced concrete panels, when compared to the reinforced concrete Clock Tower currently being built, it can be seen that comparing the construction of the tower to the alternative design, the latter is both better economically and time effective. The alternative design is to be constructed 65 days faster than that of Gilbane Building Company and the estimated total cost is approximately 5.7 million.

**[SPACE LEFT INTENTIONALLY BLANK]**

## 2.0 Background

The history of the Worcester State Hospital has a colorful past. This section will explain events that occurred with the Tower facility that lead to both its deconstruction and reconstruction. It also provides a profile of the major parties involved with this project along with an overview of the Project Management aspect of the Tower.

### 2.1 History of the Worcester Insane Asylum

The Worcester State Hospital first opened on January 12, 1833, and was originally named the Worcester Lunatic Asylum. This was the first building to provide for the mentally insane in the state of Massachusetts. Within the first several years of opening overcrowding started to become a serious issue which needed to be addressed (Asylum Projects). Despite the necessity for new space and funds, the state legislature did not provide a solution for the Worcester Lunatic Asylum until 1869, when a tract of land near the edge of the city was purchased to build a new building complex.

This new building structure followed the Kirkbride Plan; which consisted of having a central administration building with staggered wings stemming from both sides (Opacity, 2009). This particular building style became very popular in the nineteenth century when planning for the treatment of the mentally ill within the United States. The structure was believed to place patients in a natural environment with abundant fresh air and natural light which would contribute to a healthy environment and a more jovial atmosphere (Kirkbride, 2008). Construction of the Kirkbride building began in 1873 and was designed by architect George Dutton Rand of Weston and Rand. After three years of construction, in 1877, the flagstone and brick building, standing four stories tall was completed with a gothic clock tower building as a part of the central administration building (Opacity, 2009), as seen in Figure 1.



Figure 1: Insane Hospital, Worcester, Mass. 1906 postcard

Over the next seventy years, the Kirkbride building provided adequate space for the patients. In the 1950's, the number of patients and staff reached about three thousand and to relieve overcrowding again, another structure named the Bryan Building was erected on campus. This building provided a more modern environment for the treatment of the mentally ill. During the 1960's, when deinstitutionalization movements took hold, many patients were moved out of the outdated Kirkbride building leaving it somewhat empty during the 1980's (Opacity, 2009). On July 22<sup>nd</sup> 1991, a massive fire engulfed the Kirkbride building, destroying almost all of the roofs and floors along most of the building besides the central administrative area. After this fire, the Kirkbride was no longer considered structurally safe, the building was closed and left vacant. In 2006, the site was selected as the location for a new mental health facility, as seen in Figure 2.





Figure 2: Map of New and Historical Buildings

In 1995, after the fire, the remains of the 19<sup>th</sup> century Victorian hospital complex and Clock Tower made it onto Preservation Worcester's Most Endangered Structures List. Preservation Worcester is a not-for-profit membership organization whose mission is to; "Preserve for future generations the sites and structures which are significant to the culture, history, and architecture of the city and to encourage excellence in future design" (Preservation, 2008). The organization has advocated for the preservation of the Worcester State Hospital and Clock Tower and has had the building on the Most Endangered Structures List seven times from 1991-2011; in 2010 it was also named to the Endangered Structures List of Massachusetts. Since 2006, when the site was selected for a new mental health facility location, Preservation Worcester, the Worcester Historical Commission, the Massachusetts Historical Commission, representatives of the City of Worcester, and concerned local citizens have been working with the Massachusetts Department of Capital Assessment Management and Maintenance (DCAMM) and the Department of Mental Health (DMH) to assure the preservation of the Clock Tower and the Hooper Turret (Preservation, 2008). Without the dedication of the Preservation Worcester and the other organizations, the buildings that remained from the fire would have

been demolished to make way for the new health facility and that piece of Worcester history would have been lost forever.

## **2.2 DCAMM**

Administration and Finance (A&F) is the Massachusetts Executive office that is committed to building a better Commonwealth for the community. The Division of Capital Asset Management and Maintenance (DCAMM) is an agency within this office that is responsible for integrated facilities management, major public building construction, and dealing with real estate services for Massachusetts. This agency was founded in 1980 by the Legislature in order to promote quality and integrity in the management and construction of the Commonwealth's capital and real estate assets (Commonwealth of Massachusetts, 2014).

DCAMM manages 5.5 million square feet of state building with millions more to become under management within the upcoming years. DCAMM is used to assist their client agencies using comprehensive and cost-effective maintenance and management strategies and standards (Commonwealth of Massachusetts, 2014). Their projects go from a wide variety of construction to renovation and repairs of structures such as academic buildings, courthouses, correctional facilities, and recreational facilities. "DCAMM is proud to be able to facilitate honoring the long standing history of public mental health care in the Commonwealth through our participation in the design and construction of this memorial clock tower," said Division of Capital Asset Management Commissioner Carole Cornelison.

## **2.3 Costello Dismantling**

Costello Dismantling is a family run business that is best known for their attention to safety. Dan Costello founded and incorporated the company in 1985 and their headquarters is

located in West Wareham, Massachusetts. The company now makes an average annual revenue of \$6,800,000 and employs a staff of approximately 50 workers. The company makes this money by reselling the scrap materials such as metals and wood. In some cases the resale value of some metals far exceeds the cost of the demolition. It is on jobs like this where Costello has to pay the owner of the building for the right to tear it down and scrap it. Some of Costello's jobs have produced more than \$1 million in proceeds from salvage. The demolition several years ago of a 19th-century textile mill in New Bedford, Massachusetts, yielded more than \$300,000 for the wood alone. This wood was carefully preserved Southern yellow pine that was sold to different sawmills to be turned into flooring. Shredded scrap steel recently have sold for nearly \$400 per ton (The Wall Street Journal, 2012). Other projects that Costello Dismantling Inc. have been a part of are the Newton North High School, Plymouth Cordage Mill, Massachusetts General Hospital, Taunton State Hospital, and many more.

There was a great desire to preserve the tower mostly due to the fire damages it received in 1991. So a decision was made to deconstruct and reassemble the clock tower on site. This project is estimated to cost about \$15 million dollars. The Massachusetts Department of Capital Asset Management and Maintenance (DCAMM) hired Gilbane Building Company as General Contractor and Construction Manager in order for them to supervise this project. Costello Dismantling collaborated with DCAMM and Gilbane Building Company in order to create a work plan in order to deal with the dismantling and construction adjacent to an occupied hospital. The team employed over 20 contractors which included engineers, health and safety professionals, masonry restoration workers, clock repair specialists, and environmental protectors.

The deconstruction of the tower proved to be a long and painstaking process. The process involved the removal of each stone by hand, numbering, photographing, and then cataloging each in order that the stones could be put back in the same place when the tower

was erected. The deconstruction team consisted of a crew of 17 masons, 13 environmental professionals, 15 demolition specialists, 2 engineers, and 4 full-time safety officers. It is with this crew that the dismantling of the tower was able to go injury free even with working at dangerous heights, as seen in Figure 3. Dealing with the height of the tower was the main problem the crew had to deal with. The dismantling crew used 150 foot tall boom lifts and man baskets suspended from cranes in order to reach the top of the 135 foot tower. If a mechanical failure were to occur, it would leave a worker stranded in the basket. In order to compensate for this there were always two lifts on the jobsite that were capable of rescuing a stranded worker at any height.



Figure 3: Costello dismantling the Clock Tower

To go along with these safety cranes there was also a specially trained Aerial Rescue Team that would know exactly what to do in a situation of a necessary rescue. There was one incident where a worker did become stranded and needed saving due to mechanical failure, but he was successfully rescued with zero time loss from the incident. Another way Costello dealt

with the hazardous job was by hiring a falling debris engineer to study the jobsite. This engineer studied the tower and located the potential fall zone of debris from the building of a radius about 40% of the building's height.

The demolition of the tower was completed in March, 2013 with over 13,000 man-hours put into the deconstruction, remediation, and dismantling. All of these work hours resulted in zero loss time accidents. This was achieved by the collaborative work between Costello Dismantling, Gilbane Building Company, and DCAMM. On October 31<sup>st</sup>, Costello won the annual Collaboration Award, as seen in Figure 4.

## **2.4 Collaboration Award**

The World Demolition Summit has been meeting annually since 2009. This is an international convention of Contractors who are involved in the demolition equipment industry. The summit has met at the Krasnapolsky Grand Hotel in Amsterdam, Netherlands since its first convention in 2009. Each year the summit gives ten different awards including: The Manufacturer's Innovation Award, Explosive Demolition Award, Recycling and Environmental Award, Safety and Training Award, and Contractor of the Year Award. The Collaboration Award was awarded to Costello for their high degree of collaboration from all parties involved, demolition contractor, main coordinator, client etc. Statements and information were required from all participating parties and such entries needed to show clear levels of collaboration achieved and the individual's view of success generated from the collaboration (KHL, 2012).



Figure 4: Dan Costello accepting Collaboration Award

## 2.5 Gilbane Building Company

Gilbane Building Company, which is based in Providence, Rhode Island, was founded in 1873 by the two brothers William and Thomas Gilbane. They started by building homes in Providence, but new projects such as churches, hospitals and other public buildings quickly followed. During the early 1900's Gilbane Building Company was able to survive through the Great Depression due to being known as the pioneers in construction management. They received this reputation by working on major defense projects during World War II and also working on the Smithsonian's National Air and Space Museum.

Today Gilbane Building Company is led by the fourth-generation members of the family with more than 25 offices located across the United States. During the past two decades Gilbane has completed a plethora of acknowledgeable projects such as the Lake Placid Winter Olympics Facilities, Vietnam Veterans Memorial, U.S Department of Justice, World War II Memorial, and many more. The company makes an estimated revenue value of \$2.83 Billion and are employing approximately 2,000 American workers. Also Gilbane Building Company is

ranked 14<sup>th</sup> in the 2014 Engineering News Record's Top 400 Contractors which is an improvement from being ranked 21<sup>st</sup> in the 2013 charts (The Top 400 Contractors, 2014). The Department of Mental Health has hired Gilbane Building Company as the Construction Managers. Figure 5 located below shows the construction of the tower on September 25<sup>th</sup>, 2014.



Figure 5: Gilbane's progress of Construction on the Tower

## 2.6 Ellenzweig

Ellenzweig was founded in 1965 and is a national architectural firm with its office located in Cambridge, Massachusetts. This firm specializes in master planning, programming, feasibility study, in-house laboratory planning, and architectural design services. The company uses a combination of Revit Architecture, AutoCad, and SketchUp in order to perform the visualization, planning, and designing of the wide range of buildings they have for projects. In order to help with streamlining and coordinating the project delivery process for each client, Ellenzweig uses the software known as Building Information Modeling (BIM). This software is not only able to analyze the geometry of the building, but also the spatial relationships, light analysis, geographic information, and quantities and properties of building components. Some notable project locations done by this firm are at Massachusetts Institute of Technology in 1998, Harvard University in 2001, and University of Massachusetts in 2004. Ellenzweig are the architects hired by DCAMM in order provide their expertise in programming, site analysis, design of the new facility, and eventually the construction administration services on the jobsite.

## 2.7 Construction Project Management

Construction Project Management (CPM) is the overall planning and coordination of a project from beginning to completion. The principle focus of CPM is the management of civil engineering projects including planning, scheduling, organization and control, as well as management concepts of leadership, motivation, trust, project team development, division of work, and conflict resolution. Ancillary engineering and construction practices involving financial practices, construction documents, contract negotiation and administration, quality and safety control, insurance and bonding are covered. Emphasis is given to Fundamental Engineering Economics and Risk Analysis to efficiently produce an estimation of time and cost.



### **2.7.1 Filed Sub-Bid System**

Major construction projects usually involve multiple subcontractors working under the General Contractor. In the State of Massachusetts, General Laws require the “filed sub-bid” system for selecting certain subcontractors on many public building construction projects. This law requires contractors to submit their bids in two phases. These Construction Bids are proposals to manage the undertaking of a particular construction project, beginning with a cost estimate and blueprints. Being that the Clock Tower restoration is a public building construction project, Massachusetts state law required DCAMM use the file sub-bid system. The first phase requires subcontractors to submit their bids to the Awarding Authority; DCAMM then compiles a list of sub-bids received and sends these to all general contractors interested in the project. The interested general contractors then need to submit their own bid including any file sub-bidders that will be used for the project. This system of bidding gives general contractors little control of whom they will work with (Massport, 2002).

### **2.7.2 Clock Tower Construction Management**

The Clock Tower is currently being built by Gilbane Building Company using a Construction Management (CM) delivery method approach. The construction manager running the operations of the project is, Mike Forwood. With this method, Forwood is heavily involved in the design process, working with DCAMM and Ellenzweig to create the best possible project within the budget. As the construction manager, Forwood was responsible for providing a cost estimation, consultation in design, preparation of bid packages and scheduling for the entirety of the project.

## 3.0 Alternative Design

### 3.1 Steel Structure Analysis

In this study an alternative steel structure frame to support the tower was proposed and then compared to the actual reinforced concrete design of the Worcester Memorial Clock Tower. The alternative design required determination of the structural members necessary to replicate the Worcester Memorial Clock tower within the architectural parameters specified by the architect. The most significant difference between both types of design is the method used to attach the original stone veneer which were mortared to the exterior of the cast-in-place reinforced concrete structure to as compared to the attachment of precast panels to the proposed steel structure many advantages, as well as disadvantages are present when designing a structure with steel.

#### **Advantages**

- Consistent material quality
- Lightweight and very strong
- Prefabricated- allows for quick assembly
- Precise and predictable with excellent quality control

#### **Disadvantages**

- Steel is an expensive material (more costly than masonry or concrete)
- Need for fire protection
- Frames can become unstable without proper bracing

# Level Design

The Tower is broken down into 9 levels with level 1 being the base of the tower and level 9 being the top of the roof which can be seen in Figure 6. The main structure is roughly 15 ft. x 15 ft. at the base all the way up to level 5. At level 6 the tower increases in size up until level 8 where the tower is roughly 19 ft. x 19 ft. to compensate for the expanded levels of the tower we designed panel shelves around the main structure to expand each level as shown in Appendix C.

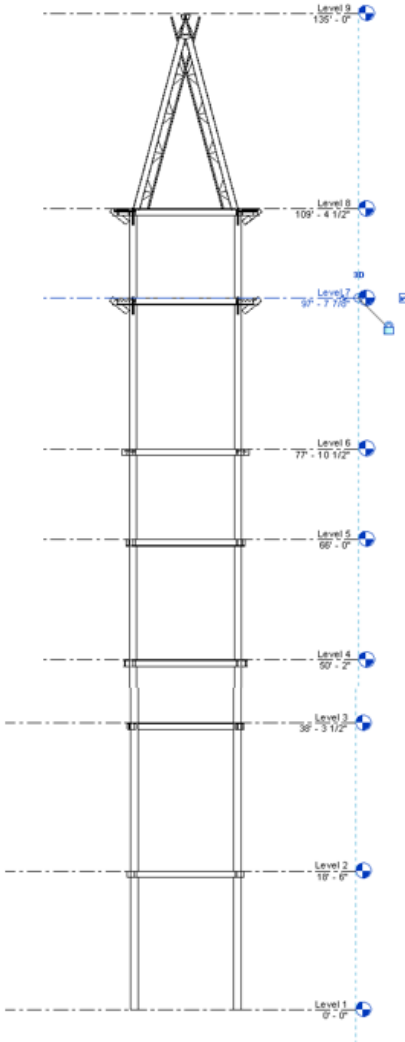

Figure 6: Tower Levels

## **Design Loads**

The design loads are critical to the structural analysis of a building. The design criteria for the analysis were taken from AISC Steel Construction Manual 13<sup>th</sup> Edition. The applicable code identified is the Massachusetts State Building Code – 9th edition. The performance requirements for the clock tower are outlined in the project specifications (Structural section). For this project, all structural design calculations will follow the American Institute of Steel Construction manual (AISC) requirements and standards. Loads taken into consideration for the design were wind, seismic, dead, and live. The two biggest loads that were accounted for were the wind and dead loads as it is a 135 foot tall structure and the weight of the attached stone panels on the clock tower are very significant.

After determining the design loads the structural design process could then begin. Using Autodesk Robot Structural Analysis (Robot) as well as performing several hand calculations the alternative design was developed in accordance with the Massachusetts State Building Code – 9th edition (see Appendix C). Figure 7 below is a 3-Dimensional representation created using (Robot), of the complete alternative design which includes the following features: steel beams, columns, concrete floors, and a mat foundation.

**[SPACE LEFT INTENTIONALLY BLANK]**

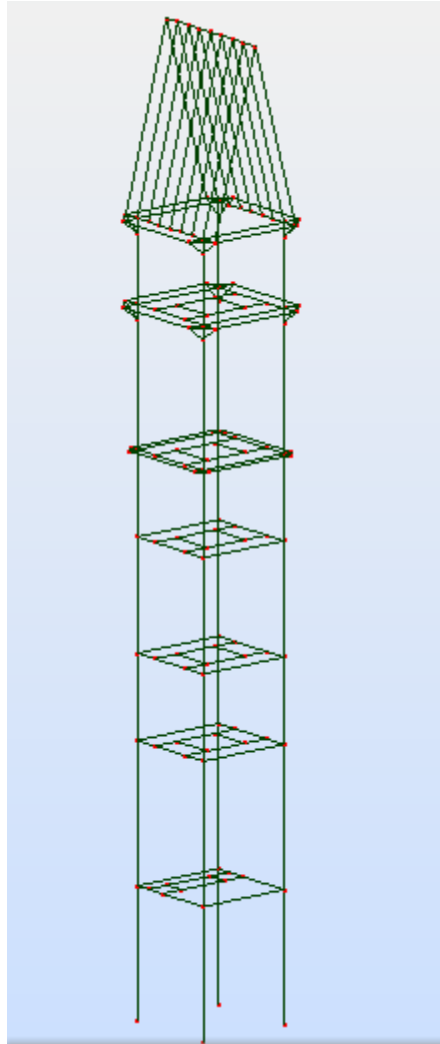

Figure 7: Robot Design

## Main Structural Steel Beam Design

The size of the structural steel beams in the tower was determined based off hand calculations performed and member sizes selected from AISC Steel Construction Manual (13<sup>th</sup> Edition). The beams are W10 x 26 steel beams and have fixed supports at both ends which can be seen in Figure 8.

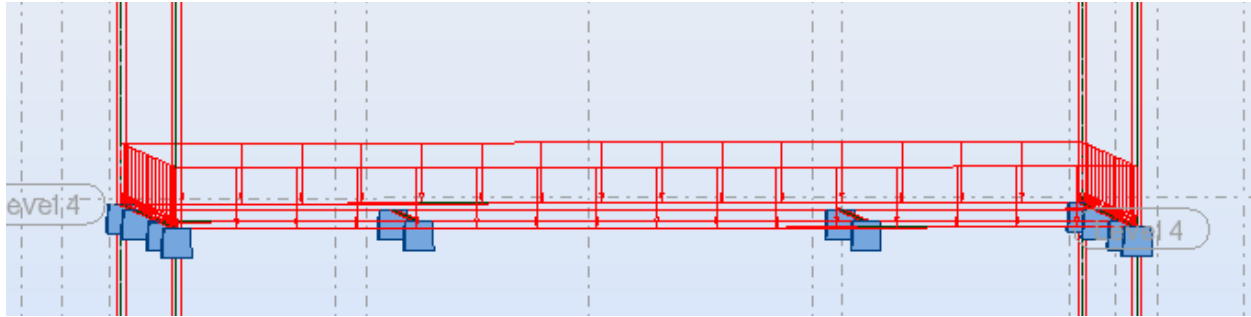

Figure 8: Steel Beam Design

### Panel Shelf Structural Steel Beam Design

The panel shelf beams designed on levels 6, 7, 8 of the tower were selected through the same process as the main structure steel beams using the AISC Steel Construction Manual. The panel beams are W10 x 22 steel beams that are attached with fixed supports of other W10 x 22 steel beam as shown in figure 9.

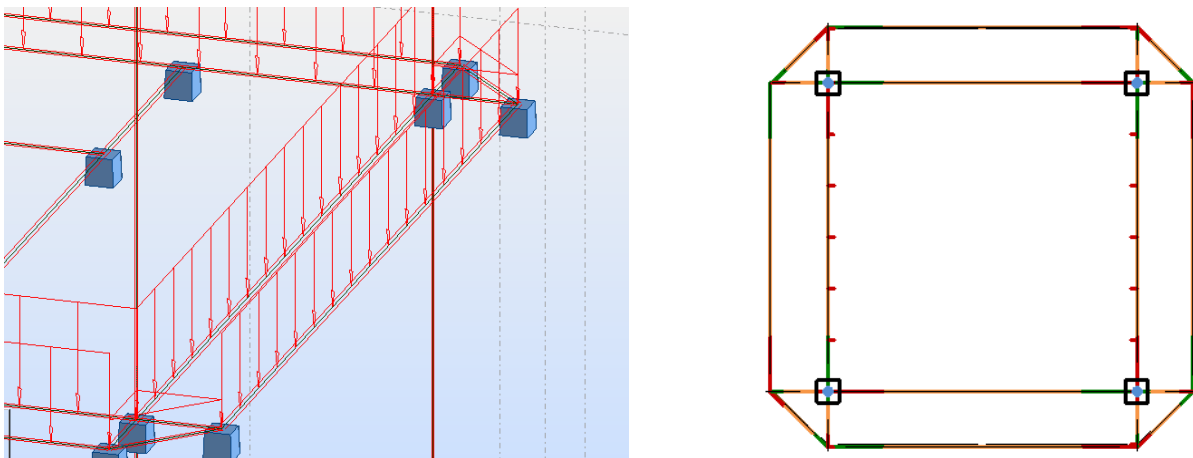

Figure 9: Panel Shelf Design

## Column Design

The Columns selected are designed to hold the sum of the forces being applied to the tower. Based off the height of the tower being 135 ft. and the total column height being nearly 110 ft. each of the 4 columns on the structure are 3 columns with fixed connections on top of one another as shown in Appendix C. There are 12 columns in the main structure.

## Mat Foundation Design

The foundation is a 20 ft. x 20 ft. x 2 ft. 6 in. mat foundation 15 ft. under the 1<sup>st</sup> level of the tower which can be seen in Figure 10.

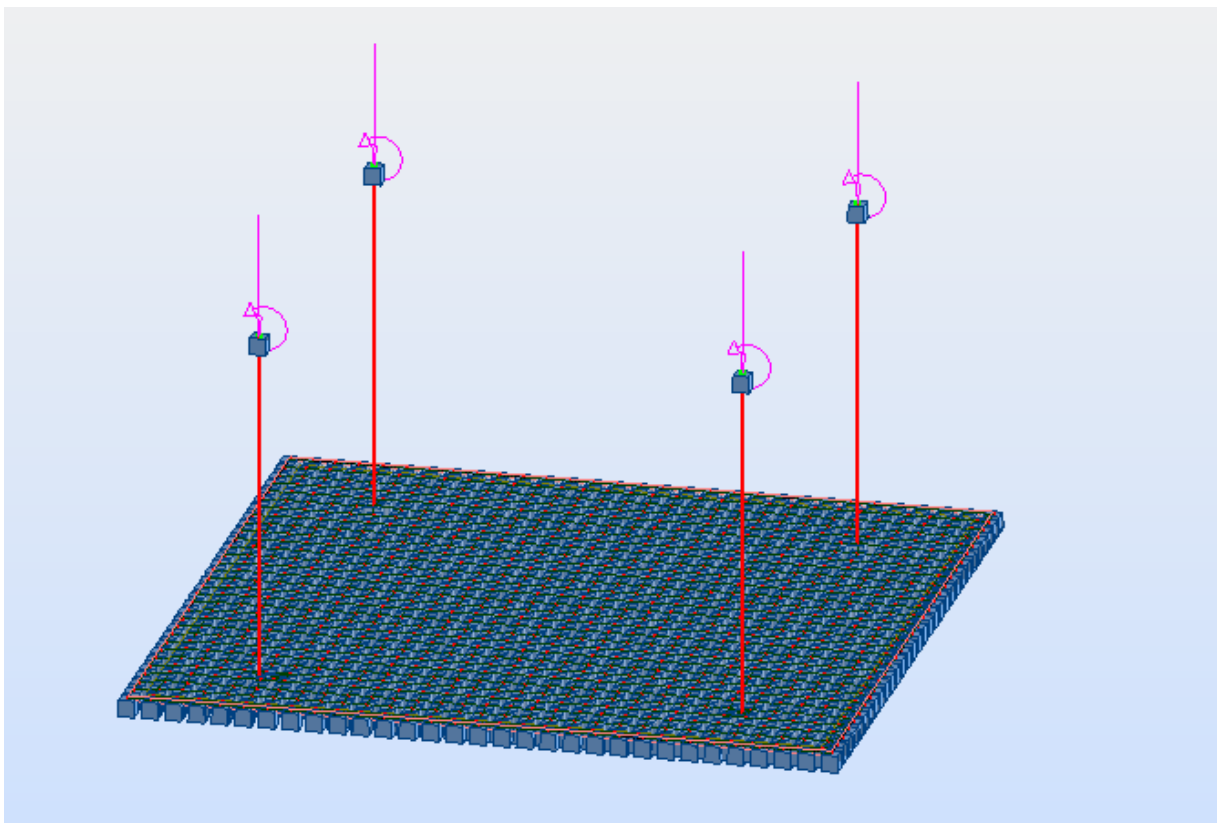

Figure 10: Mat Foundation

### 3.1.1 Steel Member Design

Hand Calculations were performed in design of the steel tower before being analyzed for testing by Autodesk Robot Structural Analysis. Every steel I-beam in the tower was designed with uniformly distributed loading to account for self-weight of the tower as well as the weight of the concrete panels. Figure 11 below shows the equations used to acquire results.

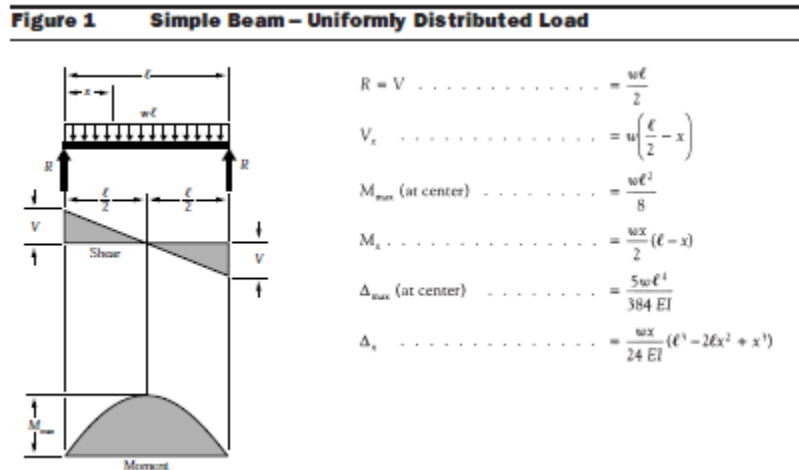

Figure 11: Uniformly Distributed Load Equations

The columns were then designed based off moment and reactions due to the beams in the tower before being analyzed by Autodesk Robot Structural Analysis. The main structure consists of 28 W10 x 26 I beams connected to 4 HSS 12" x 12" x 5/16" that rise 109' – 4 1/2" to the base of the roof and rest on a mat foundation 15 ft. below the base level. Levels 6, 7, and 8 have W10 x 22 structural beams spanning around the perimeter of their level and attached with fix supports in two places to each of the 4 columns in the main structure as shown in the Figure 12.



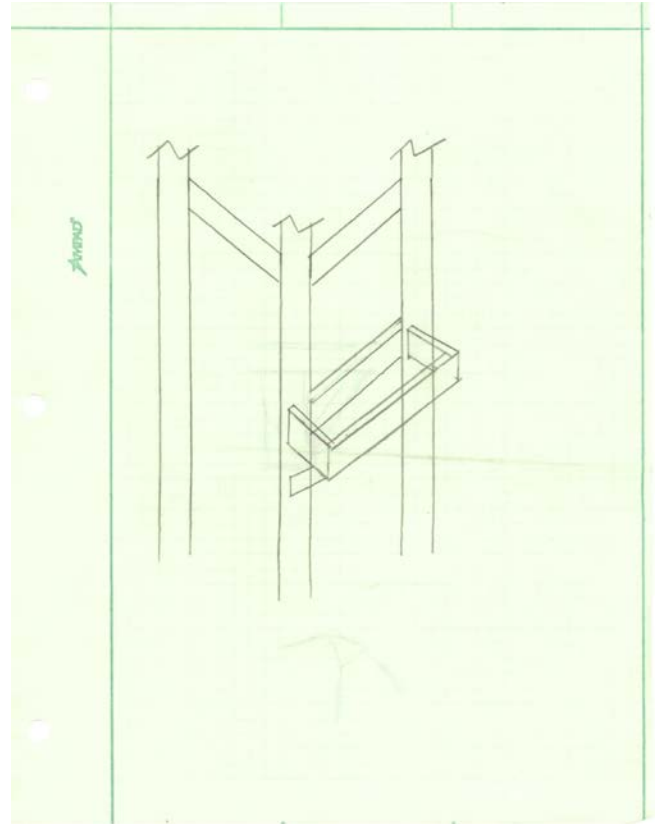

Figure 12: Fixed Support Design

## Structural Steel Bracing

Bracing was added to the column to compensate for any wind forces that will be acting on the clock tower in any direction. To obtain the wind forces calculations for velocity wind pressure, design wind pressure, and both horizontal and vertical wind forces on the tower were calculated as shown in Appendix C along with a diagram showing the placing of the bracing on each level of the tower. The bracing will be a diagonal bracing connection on each level 1 through 8 both ways with one brace spanning the full distance and the other span half the distance being fixed supported to the bracing and then spanning to the column. The bracing used is 2L3 x 2 x ¼".

### 3.2 Concrete Panel Design

In order to attach the veneer stone to the steel structure, reinforced concrete panels were designed and developed in order to hold these stones. These concrete panels were designed for each level of the tower face to be four panel sections. Also these panels were designed to be lifted by using a tilt-up-lift and then be bolted by an anchoring system on each panel to the steel structure. When using these many panels on the structure multiple flashing is necessary to ensure the structure is not damaged by water. Also due to the fact of cutting the stones into a smaller diameter in order to reduce the weight, much mortar may be needed in order to fill in any open spaces. Finally, when each panel size was determined the sizes were rounded down. This allows for us to have some play room in between each panel which can later on be filled with mortar.

A basic concrete panel sample was built in the materials laboratory to investigate how long it will take for the stones to sink into the concrete wet mix before the panel sets. A panel with the dimensions of 1'8"X10" with a depth of 5.5" was constructed in order to house reinforced concrete and four veneer ashlar stone. The stones used for this experiment were excess from the actual tower being built for this project. These extra stones were sent to Camosse Masonry Supply, Inc. to be stored and sold to future projects in need of them. The worker (Andy Turpin) of Camosse donated 4 of these stones in order for us to be able to conduct this experiment. As Appendix E shows the rebar that was calculated to be used was #3 rebar with a 3.5" spacing from each and a 1" spacing from the bottom of the panel as can be seen in Figure 13. A water-cement ratio of 0.5 was used for the concrete. The reason for this was because this ratio gave us the consistency of the cement to where it was workable and formed nicely on top of the rebar and surrounding the stones.



Figure 13: Rebar placement in panel experiment

After the concrete had cured the stones were still sticking out about 1", which was way too much compared to the actual tower. Mortar was then added on top of the hardened concrete to where only  $\frac{1}{4}$ " of the stone was sticking out. This mortar not only gave the panel the look we desired, but also provided extra strength to the panel. This experiment showed us how these panels could be constructed onsite and the stones could be added to the panels without fear of the concrete not performing well with the stones and rebar as can be seen in Figure 14.



Figure 14: Reinforcement concrete panel with stones and mortar

## **Advantages**

- Built on site
- Reduce weight of stone
- Cost Containment
- Room for error with play room in between panels

## **Disadvantages**

- Multiple flashings needed
- Possible multitude of mortar needed
- Time consuming lifting and placing each concrete panel

## **Design Loads**

The concrete designs are critical to the structural integrity of the panels. The concrete design criteria for the analysis were taken from the textbook “Structural Concrete Textbook, Volume 1”

### **3.2.1 Tilt-Up-Lift**

Tilt-up construction is one of the fastest growing methods in building construction happening in the United States. Annually about 10,000 buildings are constructed using this method. The reason for its upcoming recently is due to the fact that of the reasonable cost, low maintenance, durability, and speed of construction. It is due to all of these facts that we have chosen this method as well when applying the reinforced concrete panels to the steel structure.

When calculating for the forces required when using the tilt-up method, the moment at the pivot end of the panel must be taken into consideration. For the panels the heaviest of them will weigh 11.26 kips with a size of 10'X9.5'. This creates a moment at the one end of 225.5 k\*ft which needs to be overcome which can be seen in Appendix G. With this moment it was calculated that a force of at least 63.78 kips is needed to tilt and lift this panel which can also be seen in Appendix A. With the tilt-up design not only do the forces need to be calculated for the tilt-up, but also the concrete must be calculated to be strong enough to when it is being tilted and lifted it won't crumble under its own weight. In order for this not to happen the reinforcement bar sizes were calculated for them to be large enough to support the size of the panels and the stones in them and also not be too large to where they make the panel too heavy. It was calculated that #3 re-bar crosshatched with a spacing of 3.5" would be sufficient enough in order to reinforce the panels in order for them not to break. These calculations can be seen in Appendix F.

With these forces a heavy duty mobile crane was needed to be found in order to move these panels to their appropriate spots on the clock tower. When searching it was chosen that the appropriate company to use was Liebherr. This company produces a plethora of cranes, but the crane we had chosen was crawler crane known as the LR 1100 Crawler which can be seen in Figure 15. This crane has a max lifting capacity of 230,300 lbs and can lift to a height of 272 ft, which is more than enough for the panels to be hoisted and attached to the tower.



Figure 15: LR 1100 Crawler

### 3.2.2 Panel Anchoring System

In order for a reinforced concrete panels to be able to attach to the steel structure design an anchoring system of bolts is required. These bolts will be located on the top corners of the panels to be attached to the cantilever beams located on the tower. In order for these anchors to be strong enough the buck anchors were chosen in order to hold and attach the heavy concrete panels. This anchoring system of the buck anchors is the best choice due to the fact they attach nicely to the rebar and concrete and also they will allow mortar to flow more freely in between panels if needed.

This anchoring system will also allow for the panels to be able to sit upon one another without there being space in between so that the tower keeps a nice continuous look and the viewer cannot tell the stones were placed by panels. Also when the panels are attached, shear bolts will need to be added in order to overcome the shear force the panels will be exerting on the beams. These bolts will need to be able to withstand a shear force being exerted of 114

kip. However, with the design of having the panels sit upon a cantilever beam and the panels sitting upon themselves while being anchored to the structure, this shear force is not of huge concern which can be seen in the calculations of Appendix A.

### 3.2.3 Flashings

Flashings on a building are thin, impervious materials which are installed in order to prevent the passage of water into the structure from certain parts on the building where joints connect. Due to the fact of the tower having multiple concrete panels being attached to it along with the multiple windows, multiple flashings are needed to be added in order to help preserve the structures sustainability.

Aluminum is a common material used for flashings on structure and it will be the choice for the structure as well. Flashings can be located at the top and bottom corners of each window located on the tower. They will also be located on the actual tower with one being on top and bottom along with one located on either side as well. Due to the panel design, multiple flashings will be needed when attaching each individual panel to the steel structure. These flashings will be placed where each panel corners match up along with one being located half way in between each panel if necessary. Finally, we will also need roof flashing solely due to the fact that all roofs on structures require flashings so that there are no leaks from the ceiling of inside the structure. With these flashings being added to these locations the structures sustainability and maintainability would extremely drop due to water infiltrating the joints of design and this would cause corrosion and water damage to the connections and stability of the structure.

## 4.0 Cost Estimates and Schedule

### 4.1 Project Management

There are many aspects of construction management that change when going from a reinforced concrete structure to a steel framed structure. A new structural design calls for new construction methods a different schedule and different costs. With all of the changes that need to be made, there are still smaller components of the Clock Tower that can be constructed in the same manner and accounted for similarly in the cost estimates.

The biggest change in construction is the use of steel instead of reinforced concrete. This new structure calls for different planning and load calculations, the process of fabricating the steel and finally new plans for the erection. Equipment selection for erecting structural steel is an essential factor in the early stages of construction. The most important piece of erection equipment is the crane. Too small of a crane and there can be a lot of time lost in the moving and setting up the crane around the building. An undersized crane can also create unsafe working conditions if the crane's capacity is exceeded. An oversized crane can shoot up equipment costs so finding the balance between safety and expense is key to finding the correct crane. When comparing concrete and steel in regards to cost, concrete is the less expensive building material but can lead to more expensive labor; meanwhile steel construction is a faster method of building because of prefabrication of parts. The use of concrete may also cause delays depending on the weather and temperature during construction.

The most challenging difference in construction is the installation of the reinforced concrete panels onto the steel structure. Previously the ashlar stones were being mortared manually, one by one onto the reinforced concrete wall using a Fraco lift. With the use of concrete panels, the stones will be organized on ground level, given time to cure when fixed onto the panel and then placed onto the building. The problem we came across was the weight



of the stones being extremely heavy and difficult to place the panels on the steel columns and beams. This resulted in a big change in the anchors used to keep these stones in place. The weight of these panels at such heights also require high weight capacity cranes to lift up to the top of the 136 foot tall Clock Tower.

As many changes are being made to appropriately schedule the proposed steel structure, some activities will be staying the same. For example, the mockups of certain areas of the buildings will be made on site in order to properly design the intricate brick designs found on the walls of the building. The electrical components throughout the building will be exactly the same as before along with the plaques located on the first level. Using the schedule and costs provided by Gilbane Building Company, an accurate representation of both have been created to supplement the alternate design.

## **4.2 Clock Tower Steel Process**

In order to build a Clock Tower from steel, all of the steel framing must be prefabricated and then transported to the construction site. After looking through the different members of the Steel Fabricators of New England (SFNE), All-Steel Fabricating Co. Inc., located in North Grafton, MA was chosen to be fabricating the steel needed for the alternative Clock Tower design. With a 25 minute proximity to the construction site and a 25,000 pound flatbed delivery truck, the transportation of steel components will be accomplished in 3 days and will be done prior to April 15, 2013, which is the scheduled milestone: Foundation Complete (See Figure 18). All of the steel delivered will be stored on site located North-West of the Clock Tower foundation (See Appendix J).

The excavation process of the Clock Tower foundation is scheduled to be completed within three days, with the use of an excavator of 1 cubic yard bucket capacity. Then using

heavyweight concrete, a foundation is set and allowed to cure for a 28 day period. When the concrete foundation reaches full strength on April 15<sup>th</sup>, 2013, the erection of steel columns begins (See Figure 18).

The 4 main Columns of the tower are made up of hollow structural steel (HSS) 12X12 members that will be lifted using the Liebherr Crawler Crane (LR) 1100 that has been on site since the completion of the foundation. While one crane is responsible for the steel members, the other Liebherr Telescopic Mobile Crane (LTM) will have a man basket carrying a steel welder, giving him access to all of the structured joints. As the columns are placed, the W-10 structural beams follow simultaneously. After the Clock Tower is fully supported, the steel framing of the roof will be placed. All erection of steel is scheduled to be completed in 27 days. Time is one of the most advantageous qualities when comparing steel to concrete. Concrete naturally takes 28 days to cure to full strength. On the other-hand, prefabricated steel members are building blocks that are transported to a site and can be assembled right away.

#### **4.3 Fabrication and Installation of Concrete Panels**

On May 30<sup>th</sup>, 2013, steel erection is completed and on-site fabrication of the reinforced concrete panels begins. Each panel is framed to be about  $\frac{1}{4}$  of a wall on a single floor level, therefore 16 panels make up all 4 walls of one level. On average, these 16 panels take up an area of 400 square feet and located North of the Clock Tower, there is allocated space on the construction site for the Stone Panel Assembly to run smoothly (See Appendix J). These panels are framed in a similar manner to that of a reinforced concrete tilt-up method. The difference is the detail needed for every panel in order to accomplish the perfect arrangement of the ashlar stones, as directed by the Ellenzweig architects. Not only is precision needed for the placement of stones, but due to the differentiating window patterns of the Clock Tower, the carpenters

laying out the wooden panels must pay close attention to the sizing and edges to get the perfect fit along the wall of the Clock Tower. Once the frame is properly set, steel workers will then place #3 sized rebar along the frame, then concrete may be poured. The concrete mix being used for the panels contains Quikrete an admixture used to increase the concrete's strength in a shorter amount of time than the typical 28 day curing period. With this admixture, the tilt-up-lift process of the panel can begin in 12 days after the pouring of concrete. The tilt-up-lift method is a construction method very similar to what is known as tilt-up construction but with one difference, the lift. Tilt-up construction is when walls, usually made up of reinforced concrete, are formed horizontally as a slab and then tilted upwards with a crane and braced into position with the other slabs and roof. This method would not work with a structure that stands 136 feet tall, the concrete would not support the tensile loads. The slabs being tilted up also need the stone veneer required by the design of the Clock Tower and so, the "lift" idea came about. Instead of just tilting-up and attaching slabs together, the crane will proceed to lift the panel completely off the ground. For the panel to attach to the steel structure, a rebar and buck anchoring system is used in the design. The full lift of the panel along with the anchoring system provides for wall placement anywhere a crane can safely reach. Therefore making construction of the stone veneer a much faster process than that of the previous reinforced concrete design: with a scheduled date of completion on September 12<sup>th</sup>, 2013 (See Figure 18).

#### **4.4 Crane Logistics**

Taking full advantage of the tilt-up-lift construction process involves the necessity of a multifunctional crane. A crane that fits the description of multifunctional, in the sense of lifting capabilities (max height and max lifting weight) and movement is, the LR1100 crawler crane. Large crawler cranes need, assist cranes during assembly and so before any steel erection or panel placement occurs during the project, the LTM crane on would have already assembled

the crawler crane prior to the scheduled milestone: Foundation Complete (Figure 18). Once assembled the LR 1100 crawler crane is the source of steel, panel and material lifting for the Clock Tower. This crawler crane will have the capability of accessing the area all around the clock tower during the project (See Appendix J).



Figure 16: 2-Man Basket Crane

The LTM crane will be used simultaneously with the crawler and will have a Man Basket Crane for welding of steel and anchoring of the stone panels onto the steel beams. Having these two cranes on site will help towards a timely constructed Clock Tower. To reach a higher standard of construction safety, during every instance of crane usage, crew members licensed by the National Commission for the Certification of Crane Operators (NCCCO) will be present and operating the machinery.

## 4.5 Cost Estimates

When making cost estimations for the steel structure design, individual unit prices were taken from RSMeans 2015. Along with unit pricing, some individual costs were taken from the actual costs of Gilbane Building Company. This can be done because although the design of the structure is different, work packages like the Electrical Components and individual costs of the dedication plaques will not change between projects. A total cost estimate was then broken down into separate work packages which are found in Figure 17.

**[SPACE LEFT INTENTIONALLY BLANK]**

Work Packages	Total Cost
Site Work and Excavation	\$ 49,477.00
Concrete	\$ 16,652.00
Steel	\$ 2,437,772.50
Masonry	\$ 285,722.00
Metals	\$ 150,004.00
Waterproofing	\$ 32,961.01
Electrical	\$ 100,000.00
Roofing/Ceiling	\$ 19,083.78
Contractor Equipment	\$ 340,537.80
<b>Construction Cost</b>	<b>\$ 3,432,210.65</b>
Fees	\$ 686,442.13
Other	\$ 1,201,933.73
Location Adjustment Factor	\$ 3,830,347.08
	<b>\$ 5,718,722.94</b>

Figure 17: Cost Estimates

The construction cost of the project was \$3.4 million. With the addition of different fees and a few other varied expenses the project's total cost estimate was \$5.72 million. According to DCAMM's records, the total cost Gilbane Building Company project is estimated to be \$12 million with about half of the cost being split with the demolition of the original Clock Tower. As

construction of the actual tower continued, unexpected costs may have occurred that are not accounted for and so there is no direct relationship that can be made for the total cost of the two projects.

## 4.6 Schedule

The schedule for the project was produced using Primavera software. The starting date chosen was the same as Gilbane's, February 25th, 2013. The schedule created uses the different building activities that are associated with the alternative design of the Clock Tower to create a timeline of events. The different milestones of the project are included in Figure 18 along with their dates. These milestones give a general sense of how the building is being constructed. The schedule created shows the total duration of the project to be 200 days. This time estimate was created using some of Gilbane's Submittals and Mock-up scheduled activities can be seen in Figure 19, along with the addition of many different activities due to the differences in construction the alternative design made necessary. The Work Breakdown Schedule (WBS) list in Figure 20, displays the new elements needed for the alternative design as "Active" under Project Status and the elements taken from Gilbane are "Planned" under the Project Status. It would be difficult to compare total project time between the alternative schedule and Gilbane's schedule because of the different activities Gilbane was also responsible for such as the completion of site work around the Clock Tower; but if focused on only the Tower Construction section of their schedule, a more accurate comparison can be made. According to Gilbane's Schedule, the total time for Tower Construction lasts 265 days from June 4<sup>th</sup> 2014 to February 23<sup>rd</sup> 2015, as shown by the red arrows in Figure 21. In which case makes the schedule for the alternative design shorter by 65 days in comparison. Using a

steel structured design along with the stone panels' tilt-up-lift construction method allowed for an effective total building time.

Milestone	Date
Project Start	25-Feb-13
Foundation Complete	15-April-13
Steel Erection Complete	30-May-13
Stone Veneer Complete	12-Sep-13
Roof Complete	22-Oct-13
Clock Tower Construction Complete	22-Oct-13
Project End Date	31-Oct-13

Figure 18: Project Milestones

**[SPACE LEFT INTENTIONALLY BLANK]**



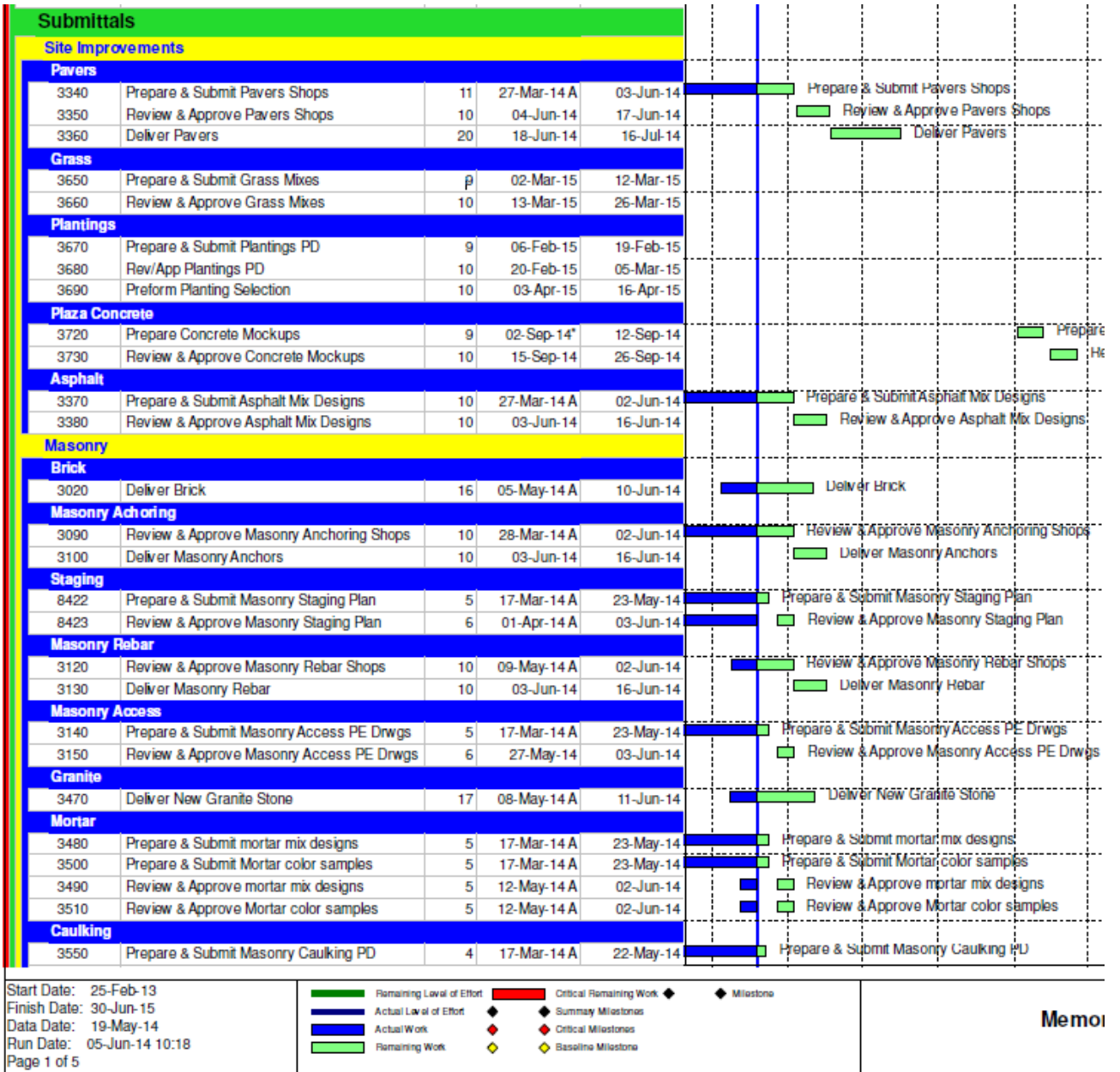

Memo

Figure 19: Project Submittals

WBS Code	Project Status
MQP	Active
MQP.Milestones	Active
MQP.Site Preparation	Active
MQP.Site Preparation.Excavation	Active
MQP.Submittals	<u>Planned</u>
MQP.Construction	Active
MQP.Construction.Mockup	Active
MQP.Construction.Mockup.Pre-Con	<u>Planned</u>
MQP.Construction.Mockup.Construction	<u>Planned</u>
MQP.Construction.Concrete	Active
MQP.Construction.Masonry	Active
MQP.Construction.Steel	Active
MQP.Construction.Windows/Louvers	Active
MQP.Construction.Metals	Active
MQP.Construction.Stone Panel Tilt Up	Active
MQP.Construction.Interior Elements	Active
MQP.Construction.Exterior Elements	Active
MQP.Construction.Waterproofing	Active
MQP.Construction.Electrical	Active
MQP.Crane Schedule	Active
MQP.Aerial Rescue Crew	Active
MQP.Clean Up	Active

Figure 20: WBS Code

Tower Construction				
Waterproofing				
6201	Mobilize Waterproofer	1	16-Jun-14	16-Jun-14
6202	Install Crystalline Waterproofing	15	17-Jun-14	08-Jul-14
6206	Waterproof to Elev 697	10	30-Jul-14	12-Aug-14
6204	Waterproof Gables	8	07-Oct-14	16-Oct-14
6203	Demobilize Waterproofer/ Caulking	2	11-Feb-15	12-Feb-15
Stonework				
6205	Scaffold & Temp Protection for Waterproofer	8	04-Jun-14	13-Jun-14
6435	Tower R/I Conduit/Boxes 1st Fir	3	12-Jun-14	16-Jun-14
6210	Mobilize Mason	1	16-Jun-14	16-Jun-14
6240	Masonry to Elev 684	30	17-Jun-14	29-Jul-14

8451	Int./Ext. 1st Lift Masonry First Floor	2	17-Jun-14	18-Jun-14
6605	Interior Concrete Slab	5	19-Jun-14	25-Jun-14
6250	Masonry to Elev 696	20	30-Jul-14	26-Aug-14
6260	Masonry to Elev 714	20	27-Aug-14	24-Sep-14
8430	Move Stone Storage Yard	15	26-Sep-14*	16-Oct-14
6270	Masonry at gables	10	07-Oct-14	20-Oct-14
6220	Masonry to Elev 627	10	21-Oct-14	03-Nov-14
6225	Balance Interior Masonry First Floor	13	21-Oct-14	06-Nov-14
6230	Masonry to Elev 647	20	04-Nov-14	02-Dec-14
6610	Install Granite Plinth	2	13-Nov-14	14-Nov-14
6615	Install Interior Pavers	2	17-Nov-14	18-Nov-14
6280	Wash Tower	10	03-Dec-14	16-Dec-14
6300	Caulking Masonry	5	17-Dec-14	23-Dec-14
6500	Install Upper Clock Dials	5	17-Dec-14	23-Dec-14
6305	A/E Create Masonry Punch List	3	24-Dec-14	29-Dec-14
6310	Demob Mason	15	30-Dec-14	20-Jan-15
6306	Mason Complete Punchlist	5	30-Dec-14	06-Jan-15
Roofing				
6340	Roof Steel Framing	5	25-Sep-14	01-Oct-14
6350	Roof Steel Decking	3	02-Oct-14	06-Oct-14
6360	Metal Ridge Assembly	1	07-Oct-14	07-Oct-14
6290	Slate Roof & Underlayment	15	17-Dec-14	08-Jan-15
6490	Install Flat Seam Roofing	4	09-Jan-15	14-Jan-15
Stairs & Ladders				
6390	Spiral Stair w/landings	20	28-Aug-14	25-Sep-14
6400	Detail finish Stairs/Railings	10	26-Sep-14	09-Oct-14
6380	Motorized Access Stair	5	10-Oct-14	16-Oct-14
6410	Caged Ladder at top	1	10-Oct-14	10-Oct-14
Interior Finishes				
8441	Install Plywood Backer Panel	1	06-Nov-14	06-Nov-14
6460	Tower R/I lights/outlets/stair tower - 2nd Fir L...	4	07-Nov-14	12-Nov-14
6480	Install Metal Ceiling	3	21-Jan-15	23-Jan-15
6440	Clock face (display)	5	26-Jan-15	30-Jan-15
6430	Elec Clock Mechanisms	4	27-Jan-15	30-Jan-15
6465	Install Clock Stand	1	30-Jan-15	30-Jan-15
6450	Clock and Bell Display	15	02-Feb-15	23-Feb-15
6470	Tower lighting/power trim	4	02-Feb-15	05-Feb-15
Exterior Elements				
6320	Lower Windows/ Louvers to Elev 714	10	21-Jan-15	03-Feb-15
6370	Iron gate	5	21-Jan-15	27-Jan-15
6420	Clock faces (upper)	4	21-Jan-15	26-Jan-15
6455	Lightning Protection	5	21-Jan-15	27-Jan-15
6325	Install plaques	2	28-Jan-15	29-Jan-15
6620	1st Fir Glass Walls/ Entrance	3	28-Jan-15	30-Jan-15
6330	Cauk Windows/ Louvers/ Gate	5	04-Feb-15	10-Feb-15
8295	EL 714 Windows/ Louvers	3	04-Feb-15	06-Feb-15
8355	A/E Create Exterior Elements Punch List	3	11-Feb-15	13-Feb-15
8365	Exterior Trades Complete Punchlist	5	17-Feb-15	23-Feb-15
Site Work				

Figure 21: Tower Waterproofing

## 5.0 Conclusion

The Worcester Clock Tower is an architectural and historical landmark to the city of Worcester and has been part of Massachusetts history for years. Due to its importance to the city, instead of having it be knocked down and remade, Preservation Worcester had each stone removed individually and be reused in the reinforced concrete structure that is being built in order to honor this historic tower.

The purpose of this Major Qualifying Project is to provide an alternate structural design and as well as supply an alternative cost and schedule then that being used right now by Gilbane Building Company. The proposed alternative design was to construct the tower as a steel structure and have the historical stones to be added by having them be placed in reinforced concrete panels and have these panels be anchored to the structure. It is with this design we strived to have a more cost and time effectiveness for this project.

When building or renovating an existing structure, it is important to the owner and as well as the community that the structure maintains its integrity and sustainability for years to come. This alternative building design will be constructed faster along with having a more cost effective design. The people of Preservation Worcester have shown great interest in the renovation of this Clock Tower, while reusing the same stones located on the tower and maintaining its same look. It is with the panel design that the same authentic look of the tower can be achieved and still be structurally sound with the steel design. It is with this alternative design the Clock Tower will be constructed 65 days faster than the proposed schedule date of Gilbane Building Company and have an estimated total cost of approximately \$5.7 million.

## 6.0 References

- Morrissey, Joseph P. *The Enduring Asylum: Cycles of Institutional Reform at Worcester State Hospital*. New York: Grune & Stratton, 1980. Print.
- Grob, Gerald N. *The State and the mentally ill: A history of Worcester State Hospital in Massachusetts, 1830-1920*.
- "Worcester State Hospital." *Opacityus*. N.p., n.d. Web. 06 Mar. 2015.
- "Kirkbride Buildings - Historic Insane Asylum History." *Kirkbride Buildings History*. N.p., n.d. Web. 06 Mar. 2015.
- T. *The Future of the Clock Tower at Worcester State Hospital?* (n.d.): n. pag. Web.
- *The Wall Street Journal*. Dow Jones & Company, n.d. Web. 06 Mar. 2015.
- "The Top 400 Contractors." *The 2014 Top 400 Contractors| ENR: Engineering News Record*, n.d. Web. 06 Mar. 2015.
- KHL Group - Demolition Summit 2012." *KHL Group - Demolition Summit 2012*. N.p., n.d. Web. 06 Mar. 2015.
- 17, Exhibit. *Description of Filed Sub-Bid System* (n.d.): n. pag. Web.
- "WORCESTER CLOCK TOWER." *Precision Dismantling of Worcester Clock Tower*. N.p., n.d. Web. 06 Mar. 2015.
- "Delivery Methods | A&P." *Delivery Methods | A&P*. N.p., n.d. Web. 06 Mar. 2015.
- "GoLocalWorcester | News | BREAKING: Deal Struck for Worcester State Hospital Clock Tower." *GoLocalWorcester Main*. N.p., n.d. Web. 06 Mar. 2015.

## 7.0 Appendices

# Appendix A-Force Calculations

### 8<sup>th</sup> Level

#### Weight of Stone

$$W_s = (132.875 \text{ ft}^2)(1.25 \text{ ft})(162.22 \frac{\text{lbs}}{\text{ft}^3}) = 26943.73 \text{ lbs} = 26.94 \text{ Kips}$$

#### Weight of Brick

$$W_B = (49.75 \text{ ft}^3)(3.031 \text{ ft})(120 \frac{\text{lbs}}{\text{ft}^3}) = 18095.07 \text{ lbs} = 18.10 \text{ Kips}$$

$$\Sigma \text{ weight} = 45.04 \text{ Kips}$$

#### Force of Stone

$$F_s = \frac{26.94 \text{ Kips}}{(19 \text{ ft})(0.83 \text{ ft})} = 1.71 \text{ K/ft}^2$$

#### Force of Brick

$$F_B = \frac{18.10 \text{ K}}{(19 \text{ ft})(0.83 \text{ ft})} = 1.15 \text{ K/ft}^2$$

### 7<sup>th</sup> Level

$$W_s = (134.25 \text{ ft}^2)(1.25 \text{ ft})(162.22 \frac{\text{lbs}}{\text{ft}^3}) = 27222.54 \text{ lbs} = 27.22 \text{ Kips}$$

$$W_B = (9 \text{ ft}^3)(3.031 \text{ ft})(120 \frac{\text{lbs}}{\text{ft}^3}) = 3273.48 \text{ lbs} = 3.27 \text{ Kips}$$

$$\Sigma W = 30.47 \text{ Kips}$$

$$F_s = \frac{27.22 \text{ K}}{(18.583 \text{ ft})(0.83 \text{ ft})} = 1.76 \text{ K/ft}^2$$

$$F_B = \frac{3.27 \text{ K}}{(18.583 \text{ ft})(0.83 \text{ ft})} = 0.212 \text{ K/ft}^2$$

$$\Sigma F = 1.972 \text{ K/ft}^2$$

6<sup>th</sup> Level

$$W_S = (82.75 \text{ ft}^2)(1.25 \text{ ft})(162.22 \frac{\text{lbs}}{\text{ft}^3}) = 16779.63 \text{ lbs} = 16.78 \text{ kips}$$

$$W_B = (77.875 \text{ ft}^2)(3.031 \text{ ft})(120 \frac{\text{lbs}}{\text{ft}^3}) = 28324.69 \text{ lbs} = 28.32 \text{ kips}$$

$$\Sigma W = 45.1 \text{ kips}$$

$$F_S = \frac{16.78 \text{ kips}}{(16.15 \text{ ft})(.83 \text{ ft})} = 1.25 \text{ k/ft}^2$$

$$F_B = \frac{28.32 \text{ kips}}{(16.15 \text{ ft})(.83 \text{ ft})} = 2.11 \text{ k/ft}^2$$

$$\Sigma F = 3.36 \text{ k/ft}^2$$



# Appendix B-Floor Plans

Second Level

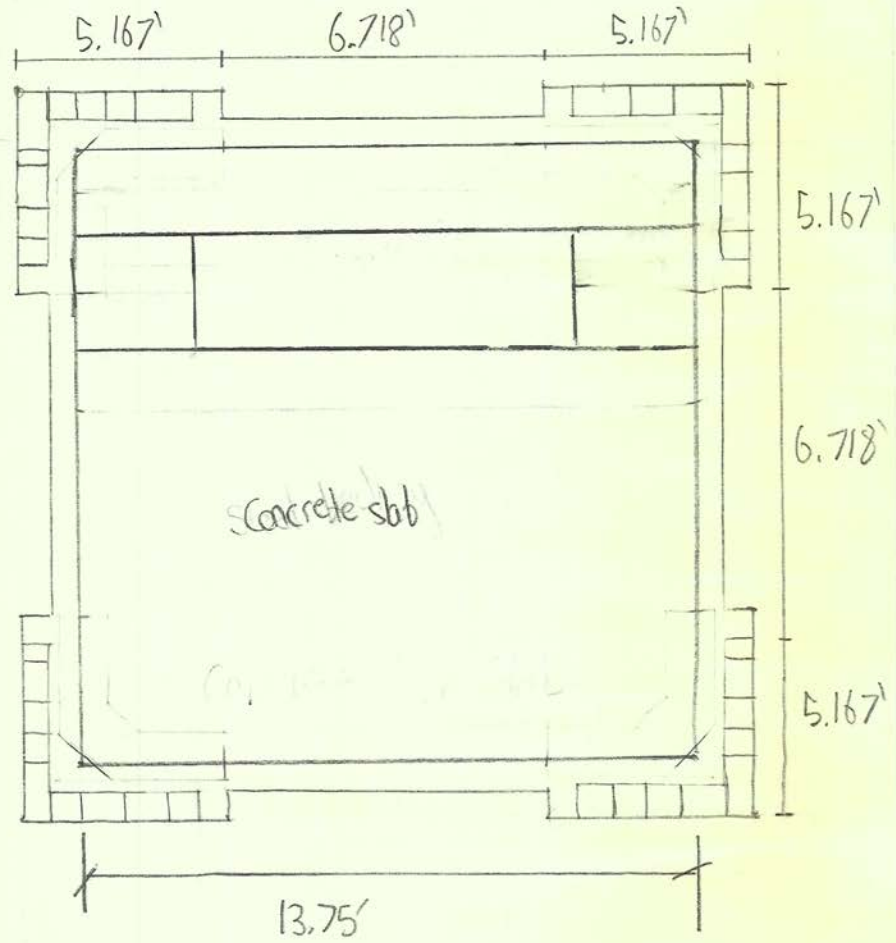

Third Level

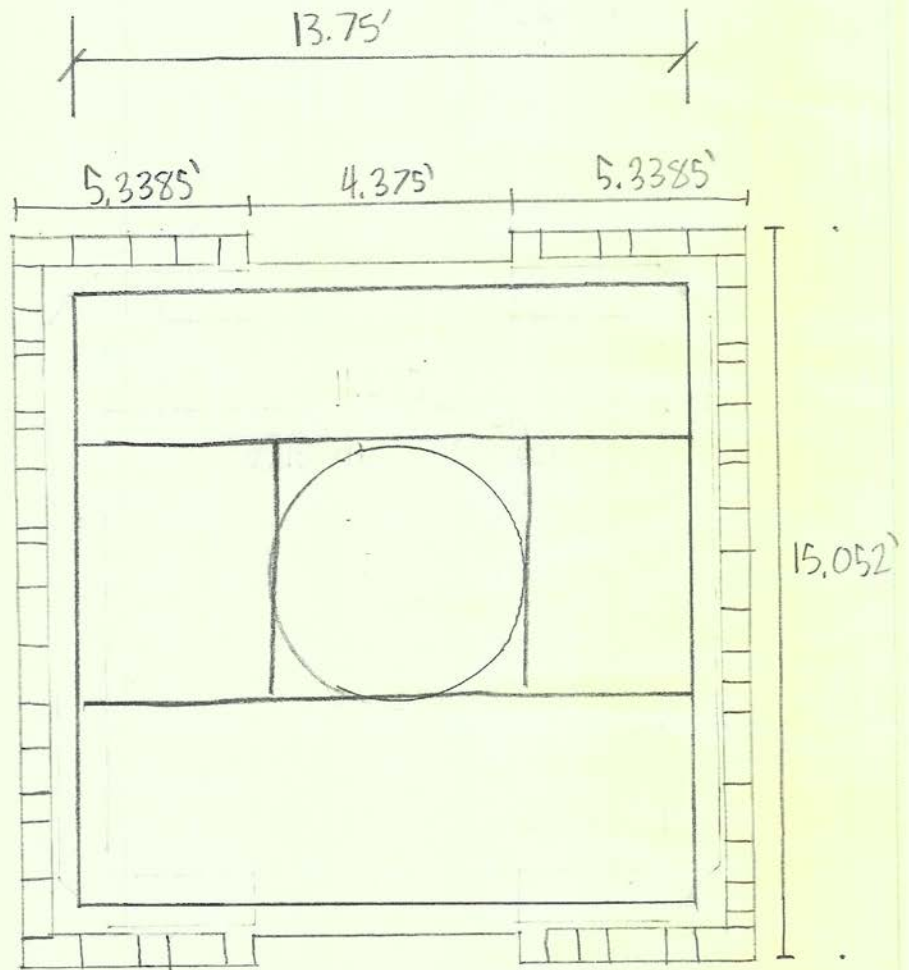

Fourth Level

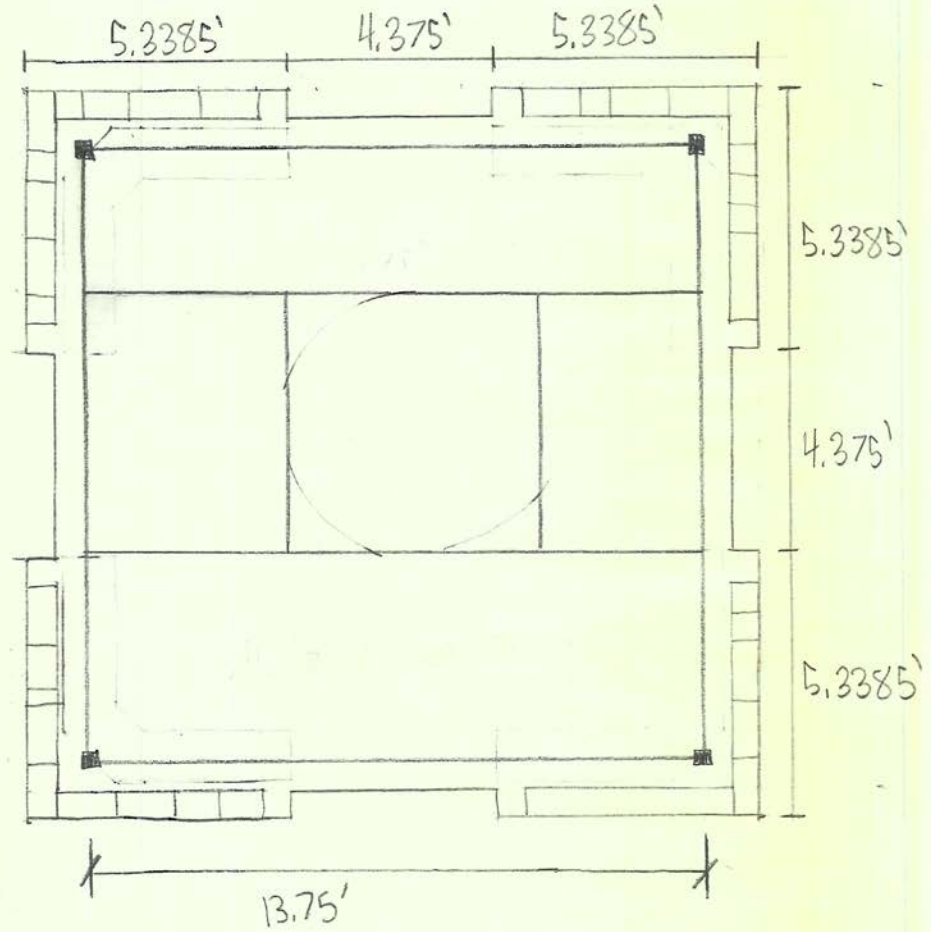

Fifth Level

200000

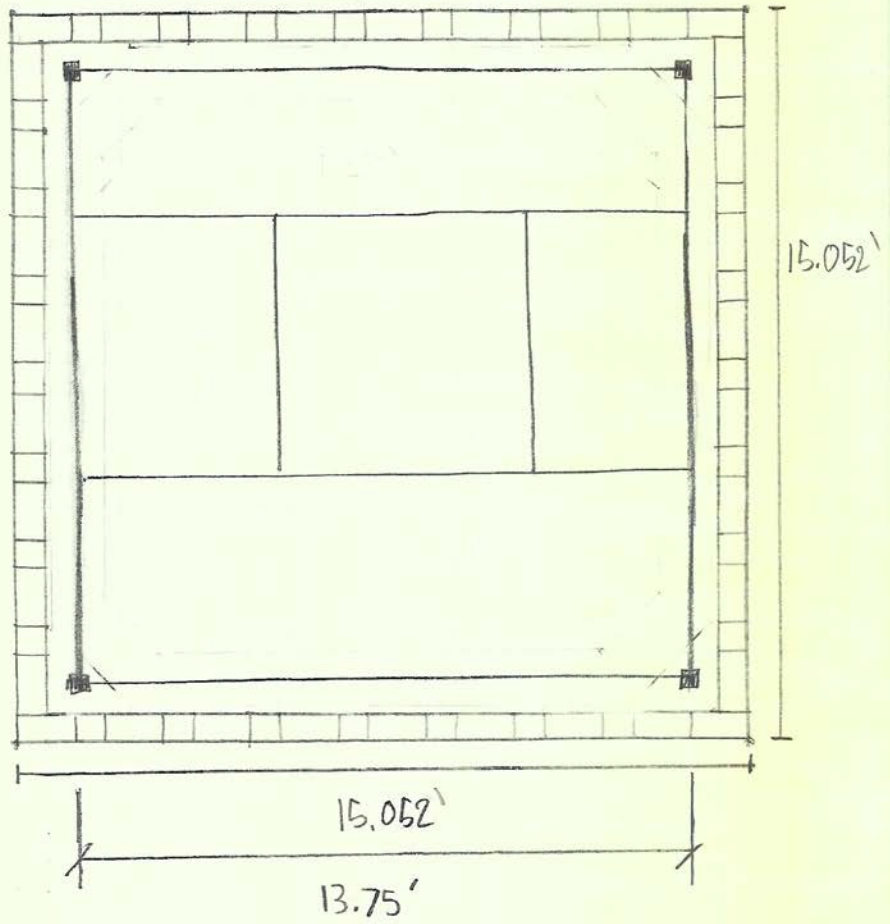

6th level

APPROX

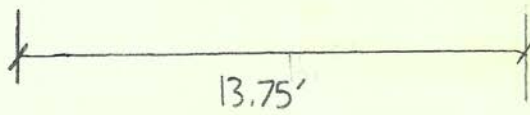
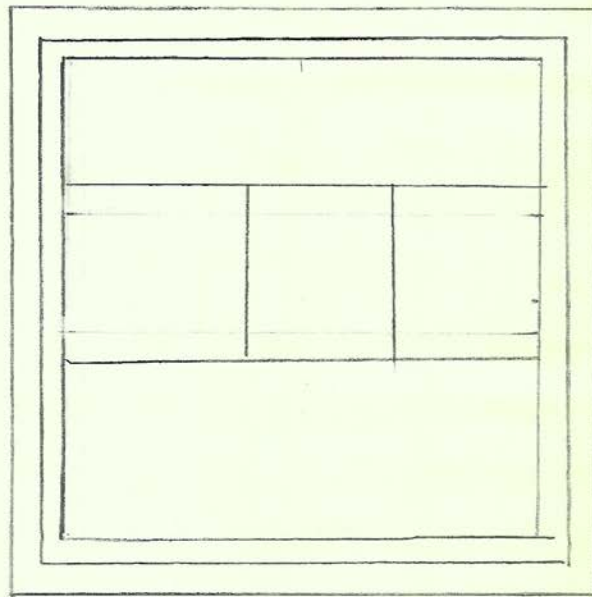

13.75'

Seventh Level

70000

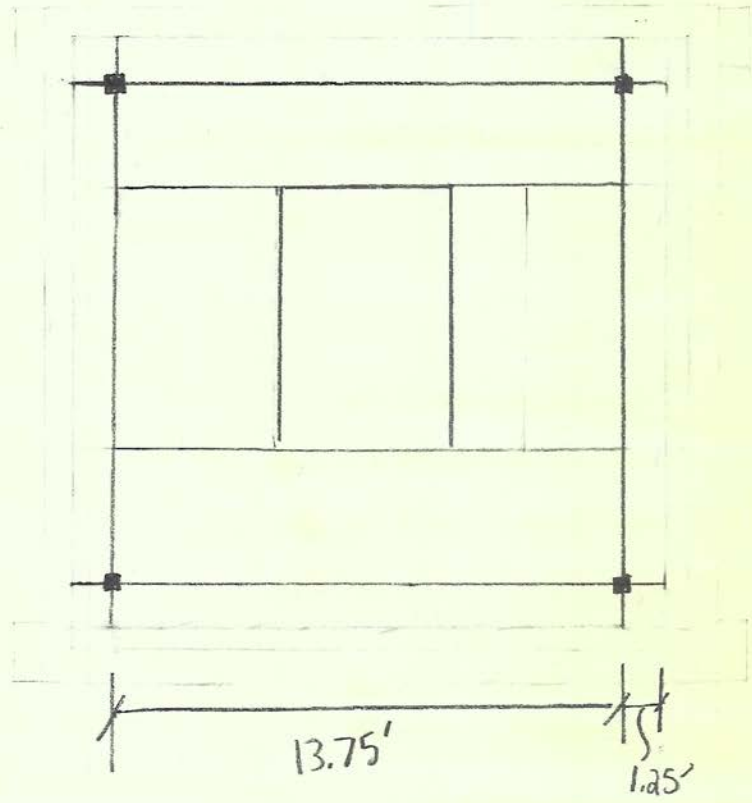

Eighth level

AMEND

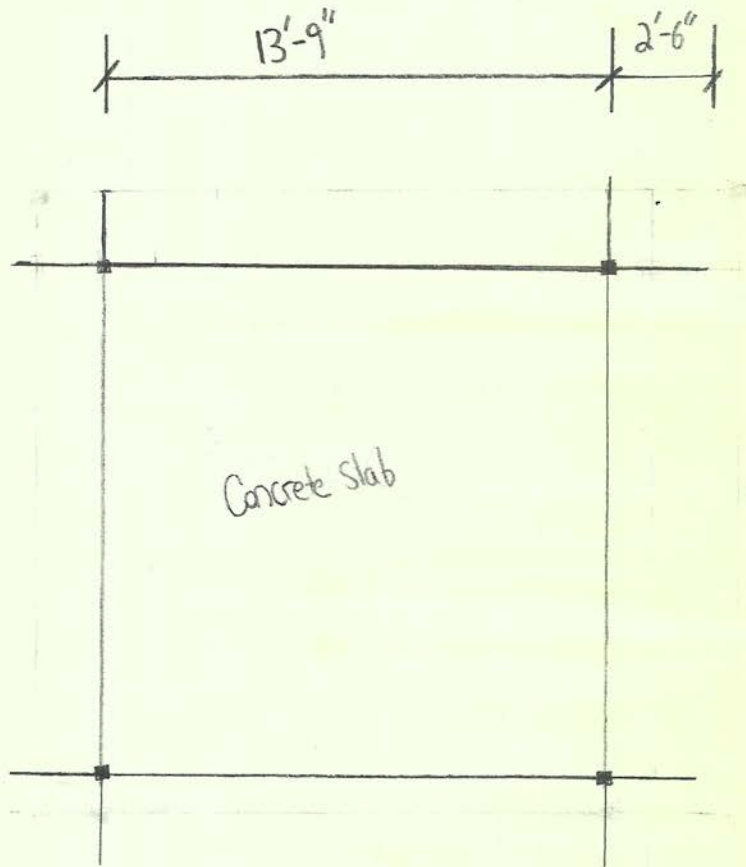



Ninth level

ANSWER

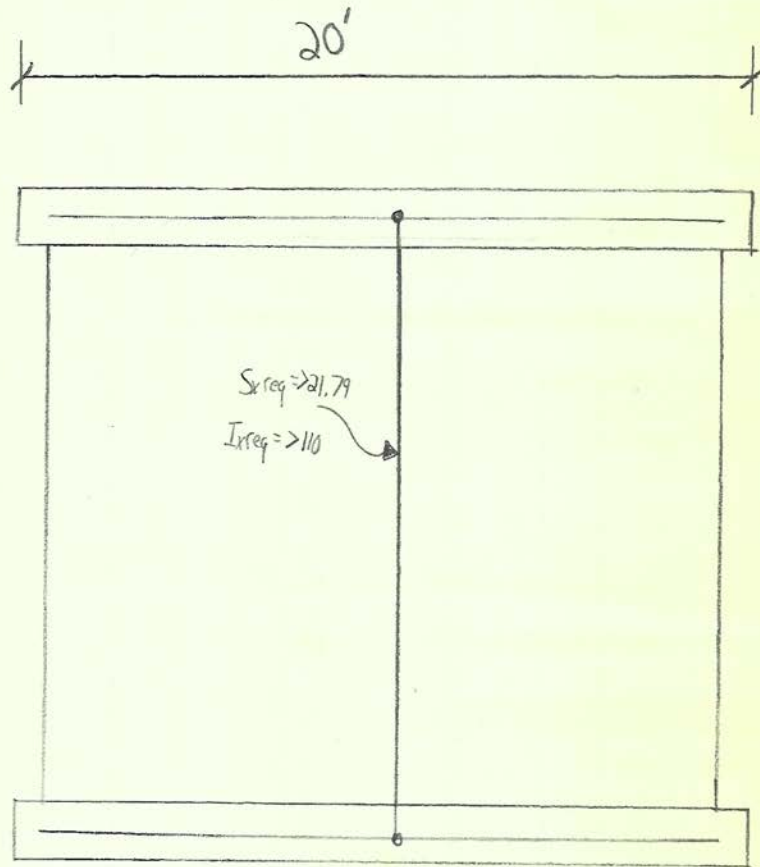

# Appendix C -Steel Calculations and Member Sizing

Velocity Wind Pressure

$$q_z = 0.00256 V^2 I K_z K_{zt} K_d$$

$$q_z = \frac{0.00256(100)^2(1)(1.09)(0.9)(1)}{1}$$

Design Wind Pressure

$$P = q_z G C_p$$

$$(25.1136)(0.85)(0.8)$$

$$P = \underline{17.07 \text{ psf}}$$

$$\begin{aligned} \Sigma M = X(13.75) &= 5.9(18.5) + 5.9(38 - 3\frac{1}{2}) + 5.9(50 - 2) + 5.9(66) \\ &+ 5.9(77 - 10\frac{1}{2}) + 5.9(97 - 7\frac{1}{8}) + 5.9(109 - 4\frac{1}{2}) + 5.9(135) \end{aligned}$$

$$X = 251.39$$

JOB Brace Design Moment Analysis

SHEET NO. \_\_\_\_\_ OF \_\_\_\_\_

CALCULATED BY \_\_\_\_\_ DATE \_\_\_\_\_

CHECKED BY \_\_\_\_\_ DATE \_\_\_\_\_

SCALE \_\_\_\_\_

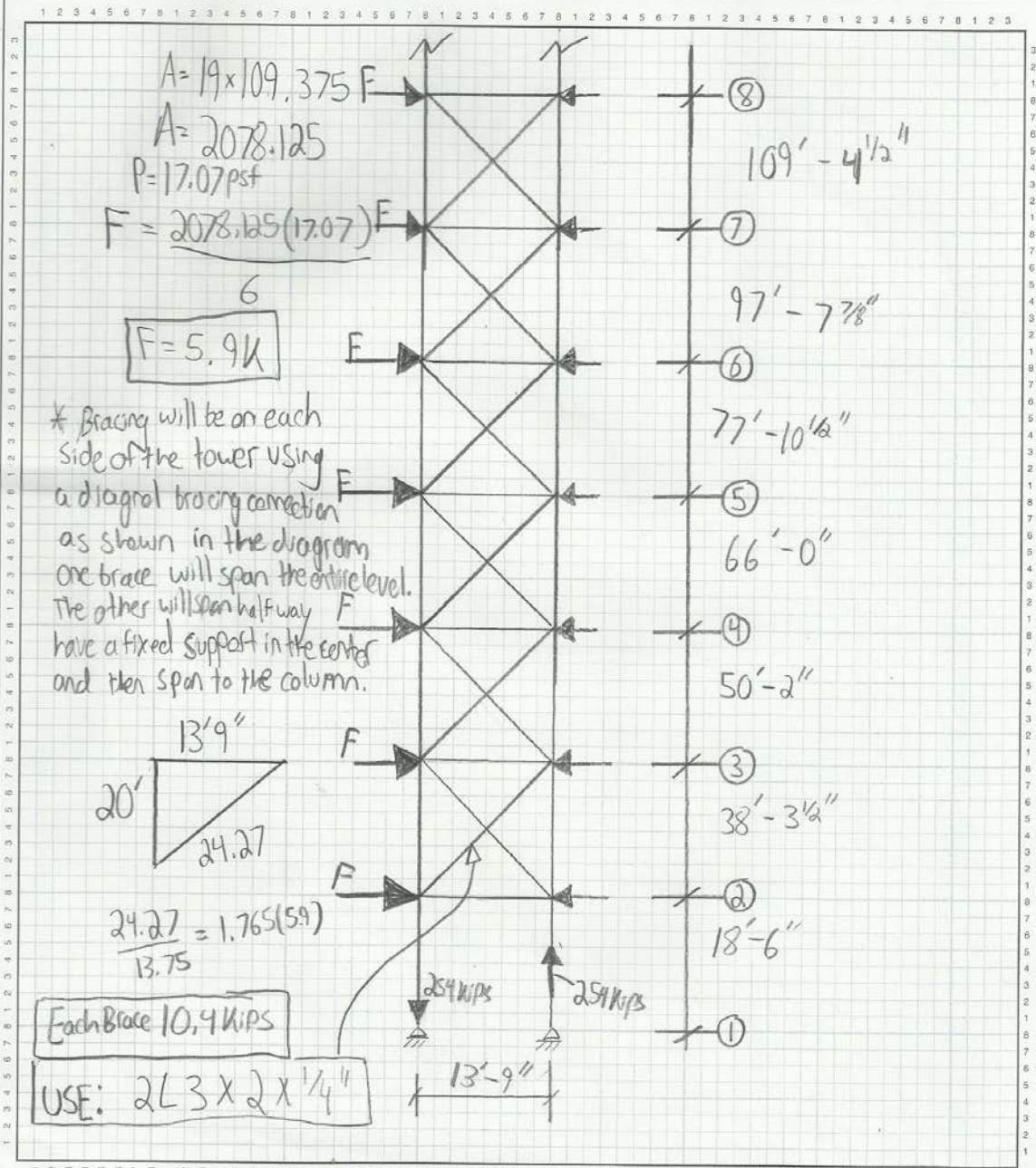

9th level

$DL = 20 \text{ PSF}$   $SL = 50 \text{ PSF}$   $L = 18'-9"$  Trib width = 10 ft

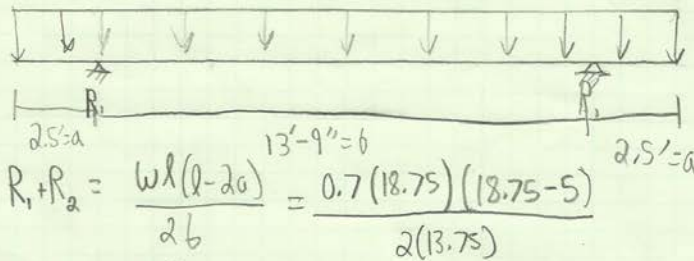

$$R_1 + R_2 = \frac{wL(L-2a)}{2b} = \frac{0.7(18.75)(18.75-5)}{2(13.75)}$$

$$R_1/R_2 = \underline{6.56 \text{ kips}}$$

$$V_1/V_4 = 0.7(2.5) = \underline{1.75 \text{ kip/ft}}$$

$$V_2/V_3 = R_1/R_2 - V_1/V_4 = \underline{4.81 \text{ kip/ft}}$$

$$M_1 = \frac{wa^2}{2} = \underline{2.1875 \text{ kip/ft}}$$

$$M_{\text{Max}} = R_1 \left( \frac{R_1}{2w} - a \right) = \underline{14.33 \text{ kip/ft}}$$

$$S_{\text{req}} = \frac{14.33(12)}{0.66(f_y = 50)} = \underline{5.21}$$

## Columns

### Loads

$$9th = 4.8 \text{ kips}$$

$$8th = 14.83 + 11.24 = 26.07 \text{ kips (2)} = 52.14 \text{ kips}$$

$$7th = 7.62 + 9.41 = 17.03 \text{ kips (2)} = 34.06 \text{ kips}$$

$$6th = 11.27 + 13.06 = 24.33 \text{ kips (2)} = 48.66 \text{ kips}$$

$$5th = 3.74 + 6.87 = 10.34 \text{ kips (2)} = 20.68 \text{ kips}$$

$$4th = 3.74 + 6.87 = 10.34 \text{ kips (2)} = 20.68 \text{ kips}$$

$$3rd = 3.74 + 6.87 = 10.34 \text{ kips (2)} = 20.68 \text{ kips}$$

$$2nd = 3.74 + 6.87 = 10.34 \text{ kips (2)} = 20.68 \text{ kips}$$

$$\Sigma \text{ Total kips} = 222.38 \text{ kips} \\ \text{per columns}$$

### Steel Size

Columns use: HHS12 x 12 x 5/16" thick steel columns



## Panel Beams

8th level

$$W = 1.63 \text{ kips}$$

$$R = 11.24 \text{ kips}$$

$$M = 38.66 \text{ kip/ft}$$

$$S_{x \text{ req}} = 16.8$$

7th level

$$W = 1.109 \text{ kips}$$

$$R = 7.62 \text{ kips}$$

$$M = 26.208 \text{ kip/ft}$$

$$S_{x \text{ req}} = 11.39$$

6th level

$$W = 1.64 \text{ kips}$$

$$R = 11.27 \text{ kips}$$

$$M = 38.75 \text{ kip/ft}$$

$$S_{x \text{ req}} = 16.85$$

5th, 4th, 3rd level  
and

$$W = 0.54 \text{ kips}$$

$$R = 3.74 \text{ kips}$$

$$M = 12.87 \text{ kip/ft}$$

$$S_{x \text{ req}} = 5.59$$

Steel size

USE - W10 x 22 steel Beams

## Main structure beams

<u>9th</u>	<u>8th</u>	<u>7th</u>	<u>6th</u>
$W = 0.7 \text{ kips}$	$W = 2.158 \text{ kips}$	$W = 1.36 \text{ kips}$	$W = 1.9 \text{ kips}$
$R = 4.8 \text{ kips}$	$R = 14.83 \text{ kips}$	$R = 9.41 \text{ kips}$	$R = 13.06 \text{ kips}$
$M = 16.59 \text{ kip-ft}$	$M = 51 \text{ kip-ft}$	$M = 32.35 \text{ kip-ft}$	$M = 44.90 \text{ kip-ft}$
$S_x = 7.19$	$S_x = 22.17$	$S_x = 14.06$	$S_x = 19.5$

5th, 4th, 3rd, and

$W = 0.455 \text{ kips}$
$R = 6.87 \text{ kips}$
$M = 23.63 \text{ kip-ft}$
$S_x = 10.27$

## Steel sizes

USE - W10x26 steel beams



Main structure beams

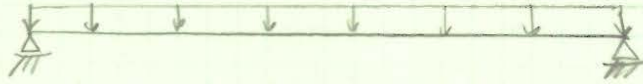

$$R = V = \frac{wl}{2}$$

$$M_{\max} = \frac{wl^2}{8}$$

$$S_x = \frac{M}{0.66 f_y}$$

$$\Delta_{\max} = \frac{5wl^4}{384EI}$$

Answer

Panel support  
Beams

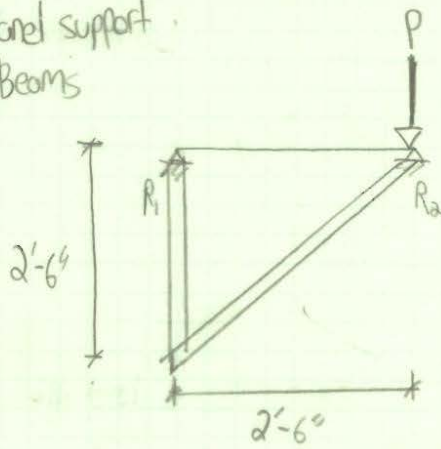

8th level

$$P = 6.79 \text{ kips}$$

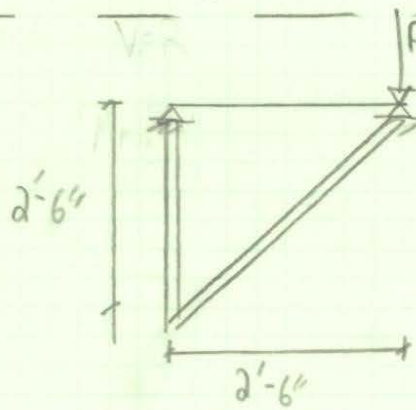

7th level

$$P = 5.91 \text{ kips}$$

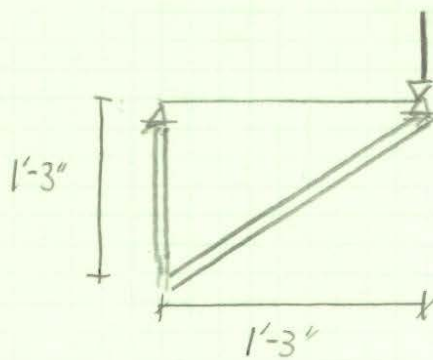

6th level

$$P = 7.83 \text{ kips}$$

# Appendix D-Mat Floor Calculations

# Mat Foundation

L x B  
20 ft x 20 ft x 2 ft 6 in

total column load

$$Q = Q_1 + Q_2 + Q_3 + Q_4$$

$$Q = 222.38(4) = 889.52 \text{ kips}$$

Pressure on soil

$$q = \frac{Q}{A} \pm \frac{M_{yx}}{I_y} \pm \frac{M_{xy}}{I_x}$$

$$M_y = 254 \text{ kip}$$

$$A = BL = 20(20) = 400$$

$$I_x = 13,333.33$$

$$I_y = 13,333.33$$

$q \geq q_{all}(\text{net})$  ← allowable soil pressure

$$q = 2.24 \geq 0.24$$

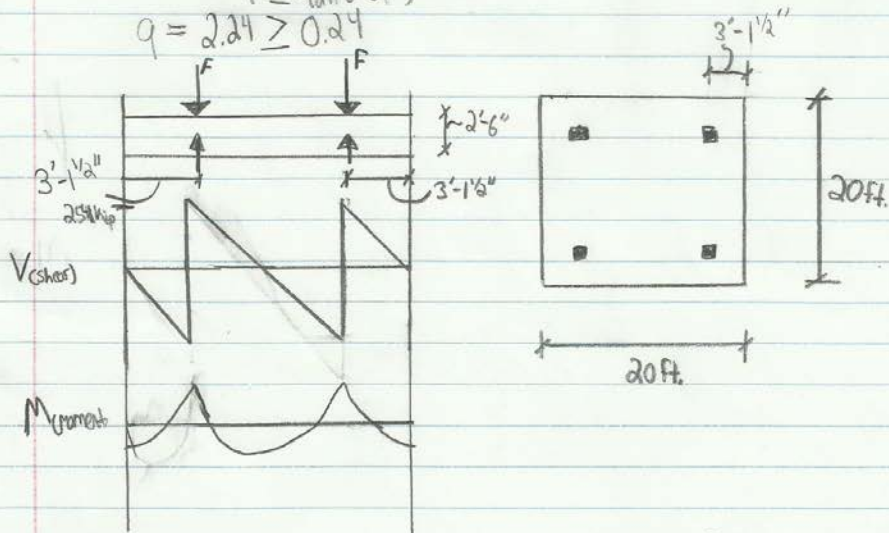

$$\text{Average load} = \frac{q_{av} B_1 B_2 + (Q_1 + Q_2 + Q_3 + Q_4)}{2}$$

$$= \frac{445.88(2.5)(20) + (889.52)}{2} = 11,591.75$$

Column load Modification Factor

$$F = \frac{\text{avg load}}{\Sigma Q} = \frac{11591.76}{889.52} = 13.03$$

Effective depth

$$U = b_o d [\phi (0.34) \sqrt{f_c}]$$

$$U = b_o d (4(0.85) \sqrt{f_c})$$

$$\phi = 0.85$$

$$U = 222.38 \text{ kips} (1.4) = 311.332$$

$$\phi V_c = \phi (4) \sqrt{f_c} b_o d$$

$$= (0.85)(4)(\sqrt{3000})(13.25 + 2d)d$$

$$b_o = (1+d) + 2(6.125 + \frac{d}{2})$$

$$b_o = 13.25 + 2d$$

$$\text{So } \frac{(0.85)(4)(\sqrt{3000})(13.25 + 2d)d}{1000} \geq 311.33$$

$$(13.25 + 2d)d \geq 1671.83$$

$$13.25d + 2d^2 \geq 1671.83$$

$$d \approx 32 \text{ in}$$

$$d = 2' - 6" = 30"$$

$$32" > 30" \quad \boxed{d \therefore \text{OK}}$$

Maximum positive and negative moment per unit width

$$M' = \frac{M}{B}$$

# Appendix E - Reinforced Panel Calculations

6<sup>th</sup> / V

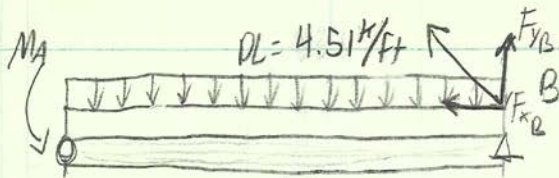

$W_c = 150 \frac{lb}{ft^3}$   
 $DL = 4.51 \frac{k}{ft}$

$Thickness(h) = \frac{l}{20} = \frac{(10' \cdot 12'')}{20} = 6''$

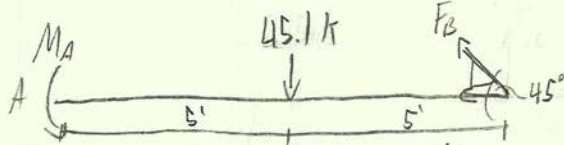

$\sum M_B = -M_A - 45.1 \text{ k}(5 \text{ ft}) \rightarrow M_A = 225.5 \text{ k} \cdot \text{ft}$

$M_A = 225.5 \text{ k} \cdot \text{ft} + 45.1 \text{ k}(5 \text{ ft}) - \sin 45 \text{ FB}(10') \rightarrow F_B = 63.78 \text{ kips}$

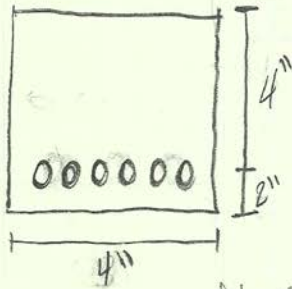

$P_{max} = .85 \beta_1 \frac{f'_c}{f_y} \left( \frac{e}{e_0 + 0.004} \right) = .85(.85) \left( \frac{4}{60} \right) \left( \frac{.003}{.007} \right) = 0.0206$

$P_{min} = \frac{3\sqrt{f'_c}}{f_y} = \frac{3\sqrt{4000}}{60000} = 0.0032$



6<sup>th</sup> Level

$$W_u = 1.2 DL = 1.2(4.51 \text{ k/ft}) = 5.412 \text{ k/ft}$$

$$M_u = \frac{W_u L^2}{8} = \frac{(5.412 \text{ k/ft})(10 \text{ ft})^2}{8} = 67.65 \text{ k}\cdot\text{ft} = 811.8 \text{ k}\cdot\text{in}$$

$$M_u \leq \phi f_y b d^2 \left(1 - 0.59 \rho \cdot \frac{f_y}{f_c}\right)$$

$$811.8 \text{ k}\cdot\text{in} \leq (0.9)(60) b d^2 \left(1 - 0.59(0.0206)\left(\frac{60}{4}\right)\right)$$

$$b d^2 > 44.17 \text{ in}^3$$

$$d^2 > 14.72 \text{ in}^2$$

$$d > 3.84 \text{ in}$$

$$h \approx d + \text{cover}$$

$$h = 3.84 + 2.5$$

$$h = 6.34 \text{ in} \rightarrow h = 8 \text{ in}$$

$$d = h - 2.5$$

$$d = 8 - 2.5$$

$$d = 5.5 \text{ in}$$

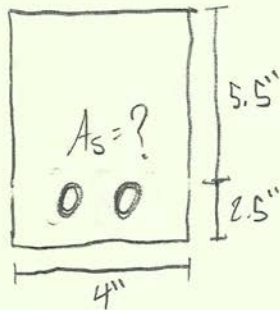

$$W_{OL} = \left(\frac{4}{12}\right)\left(\frac{8}{12}\right)(150) = 0.033 \text{ k/ft}$$

$$W_u = 1.2(4.51 + 0.033) = 5.45 \text{ k/ft}$$

$$M_u = \frac{5.45 \text{ k/ft}(10 \text{ ft})^2}{8} = 68.13 \text{ k}\cdot\text{ft}$$



$$\textcircled{1} a = 2''$$

$$A_s = \frac{M_u}{\phi f_y (d - \frac{a}{2})} = \frac{68.13 \text{ K}\cdot\text{in}}{.9(60 \text{ ksi})(5.5'' - \frac{2''}{2})} = 0.28 \text{ in}^2$$

$$a = \frac{A_s f_y}{.85 f'_c b} = \frac{(0.28 \text{ in}^2)(60 \text{ ksi})}{.85(4 \text{ ksi})(4 \text{ in})} = 1.23''$$

$$\textcircled{2} a = 1.23''$$

$$A_s = \frac{68.13}{.9(60)(5.5 - \frac{1.23}{2})} = 0.26 \text{ in}^2$$

$$a = \frac{0.26(60)}{.85(4)(4)} = 1.15''$$

$$\textcircled{3} a = 1.15''$$

$$A_s = \frac{68.13}{.9(60)(5.5 - \frac{1.15}{2})} = 0.256 \text{ in}^2 \quad \checkmark \text{ converged}$$

Solve P

$$M_u = P \phi f_y b d^2 (1 - 0.59 \cdot P \cdot \frac{f_y}{f'_c})$$

$$68.13 = P(.9)(60)(4)(5.5)^2 (1 - 0.59 \cdot P(\frac{60}{4}))$$

$$P(1 - 8.85P) = 0.0104$$

$$8.85P^2 - P + 0.0104 = 0$$

$$P = \frac{+1 \pm \sqrt{1^2 - 4(0.0104)(8.85)}}{2(8.85)} = \frac{+0.1014}{-0.0116} \quad \checkmark$$

$$A_s = P b d = 0.0116(4'')(5.5'')$$

$$A_s = 0.2552 \text{ in}^2 \rightarrow 2 \#2 \text{ bars} = 0.22 \text{ in}^2$$

# Appendix F-Cost Estimations

		Crew	Daily Output	Labor Hrs	Unit	Material	Labor	Equipment	Total	Total inc, O&P
<b><u>Site Improvements</u></b>										
<b><u>Asphalt</u></b>										
321216.1	Asphaltic Concrete Paving 3" binder	B-25	900	0.005	sf	2.16	0.22	0.27	2.65	3
<b><u>Grass</u></b>										
329219.1	Grass seed hand push spreader, 4.5lb per M.S.F	1Clab	180	0.044	M.S.F.	20	1.63		21.63	24.5
<b><u>Planting</u></b>										
329333.2	Hibiscus, 3'-4', B&B	B-17	75	0.427	Ea.	48	16.85	10.45	75.3	90
<b><u>Plaza Concrete</u></b>										
321613.1	Cast-in-Place Concrete Curbs and Gutters (040)	C-2A	500	0.096	L.F.	5.7	4.26		9.96	12.8
<b><u>Masonry</u></b>										
<b><u>Masonry</u></b>										
44310.05	1100 Ashlar Veneer (Split or rock Face- High Pri D8		120	0.333	sf	19.05	14.05		33.1	42.5
44310.45	4200 Granite 4" Thick Minimum	D13	35	1.371	sf	63	60	13.75	136.8	177
<b><u>Masonry Anchoring</u></b>										
???										
<b><u>Masonry Rebar</u></b>										
32111.6	Reinforcing in Place (2410) #5	2 Rod	435	0.037	Ea.	1.15	1.86		3.01	4.19
32113.1	Galvanized Reinforcing (0150)				Ton	460			460	505
<b><u>Concrete Panels (tilt up)</u></b>										
33053.4	Concrete in Place (4260) 12"thick, 8'high	C-14D	64.32	3.109	C.Y	142	142	11.55	295.6	390

# Appendix G-Project Schedule

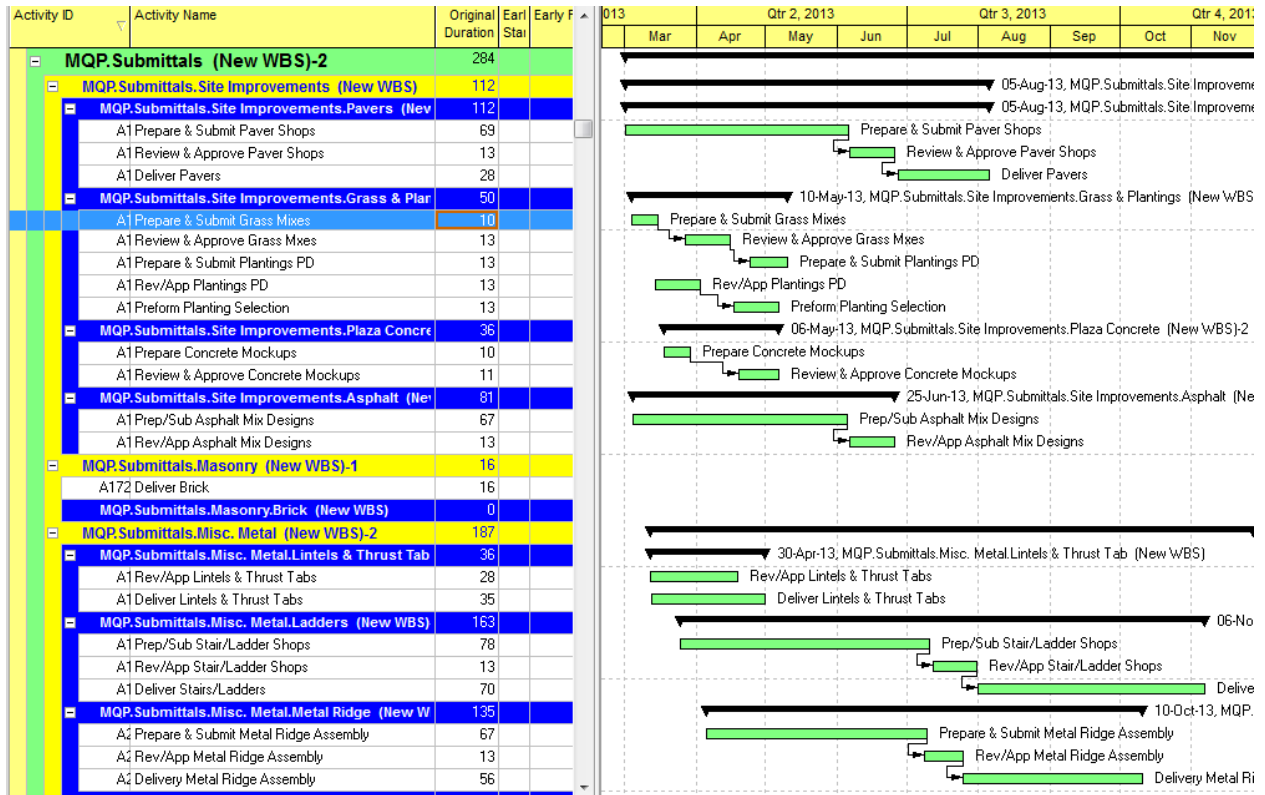

# Work Breakdown Structure

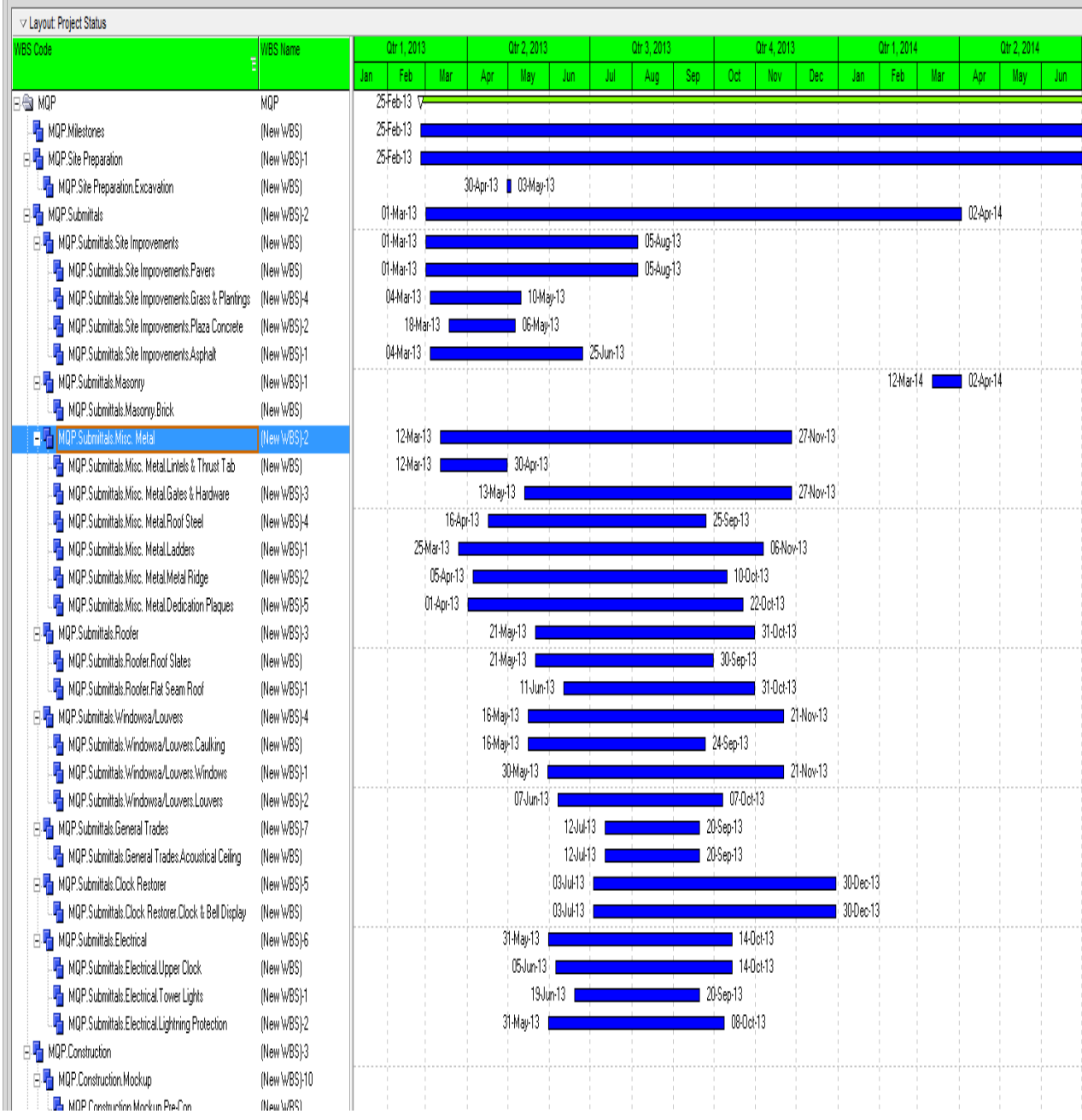

# Appendix H-SAP Model

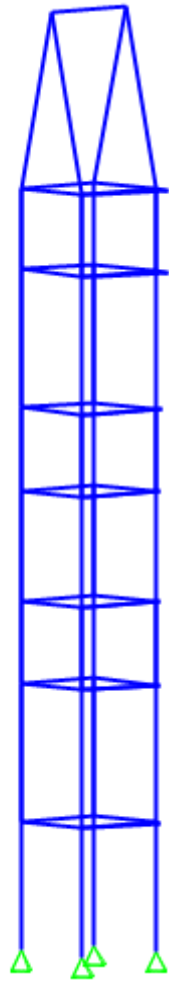



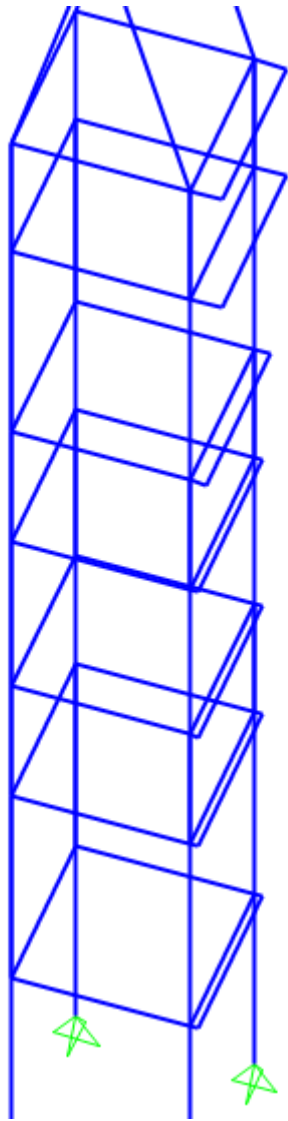

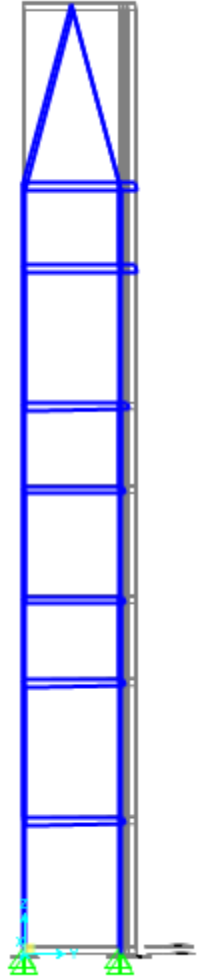

# Appendix I-Detail Drawings

Detail section for stone panel design

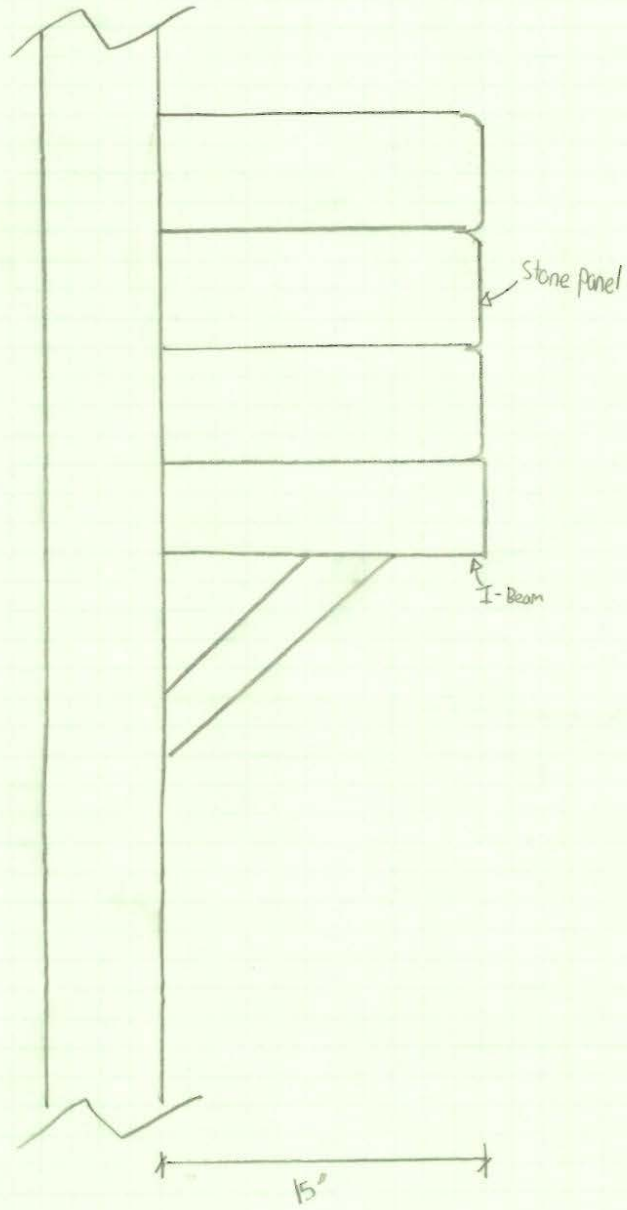

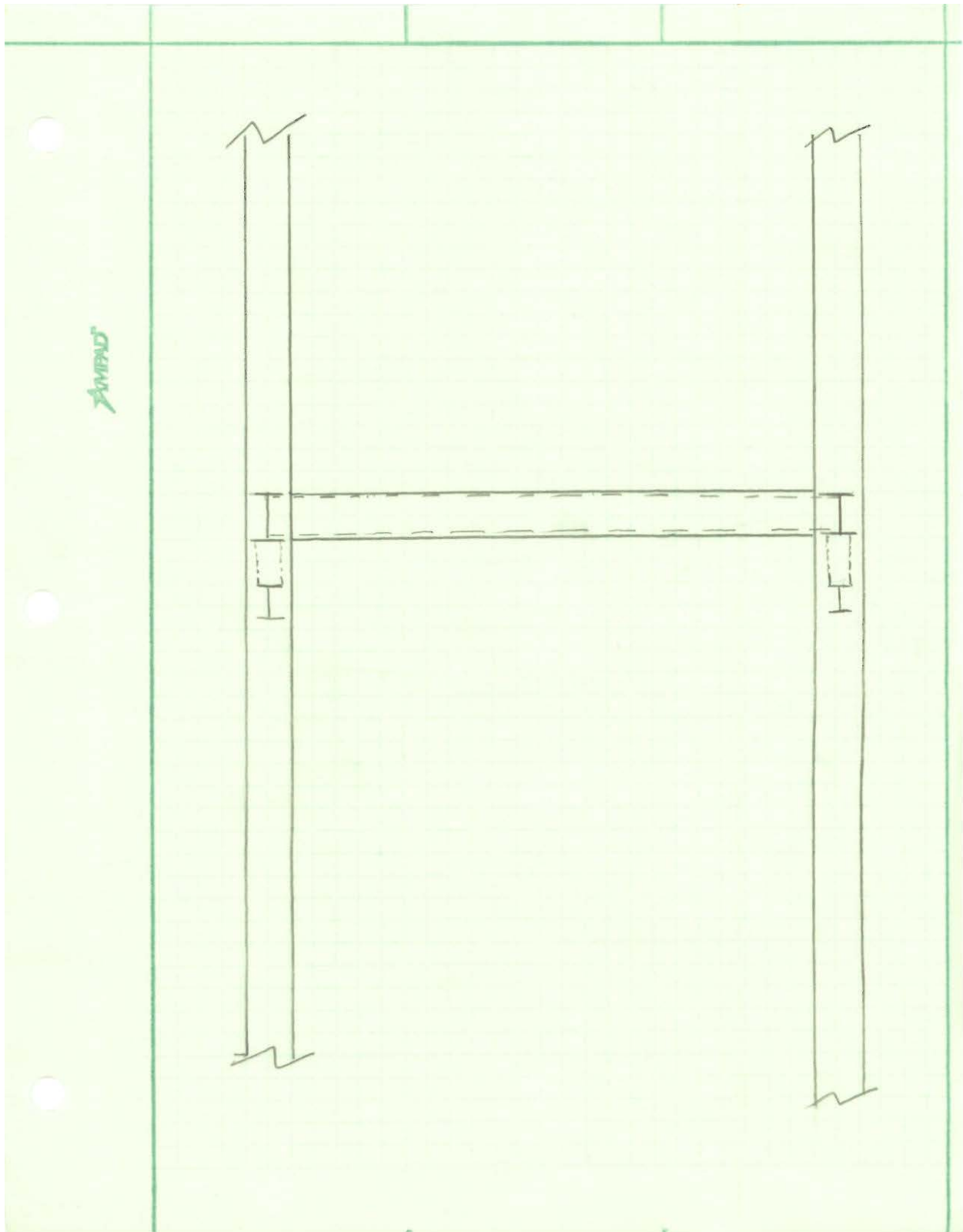

Amiad

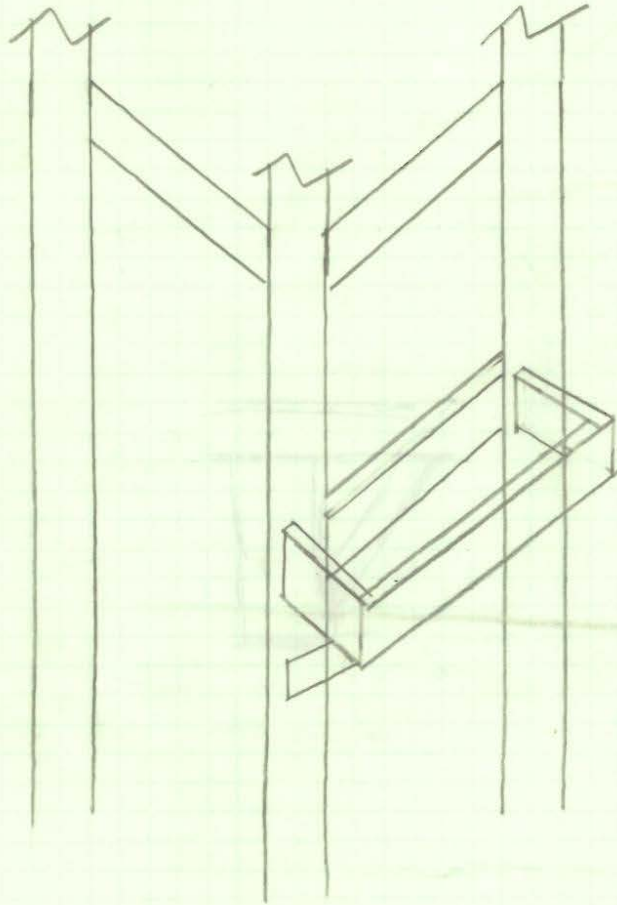

# Appendix J-Site Plans

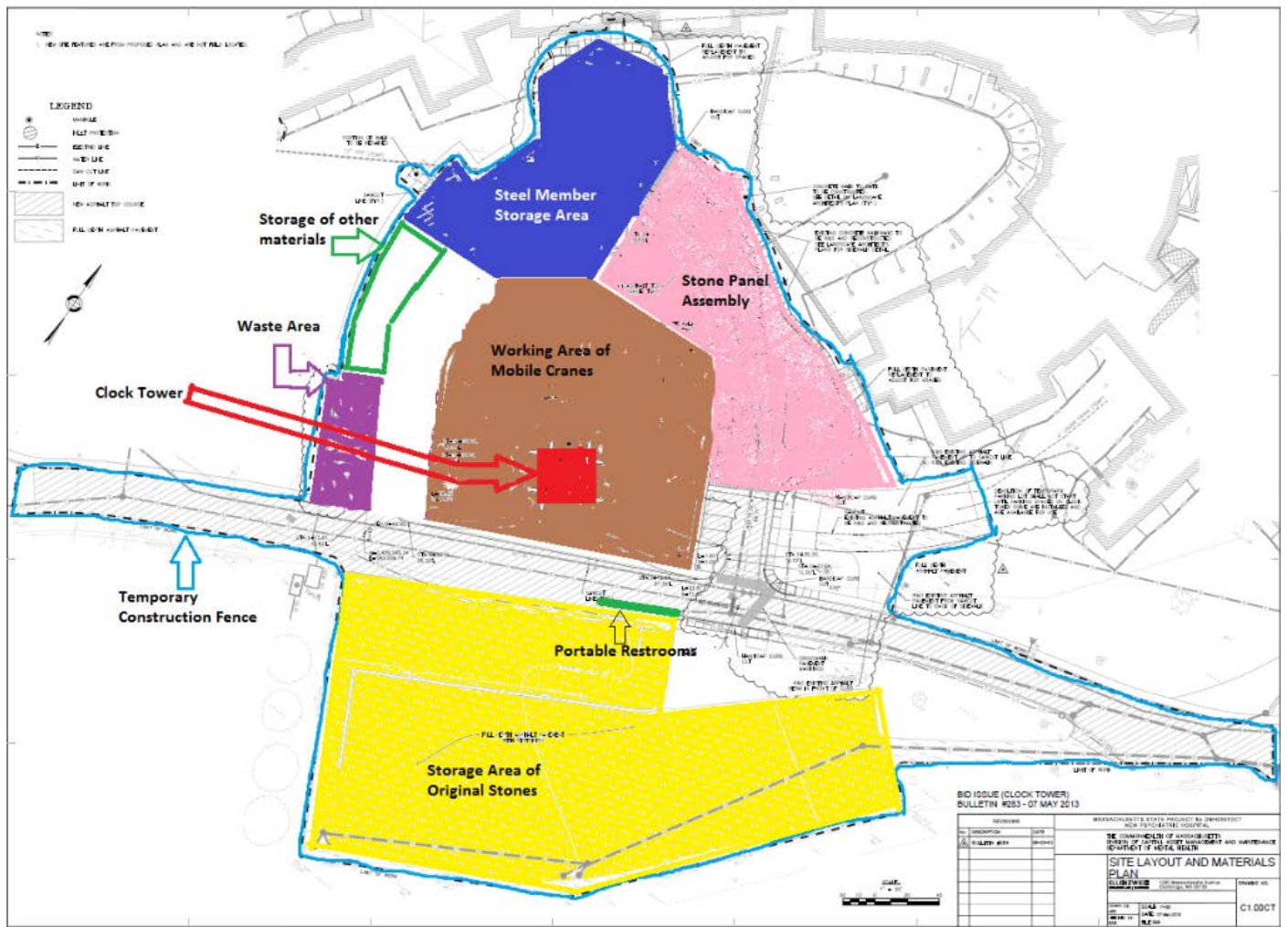



## Appendix K - WBS Timeline



## Appendix L – Activity Schedule



## Appendix M – Activity List

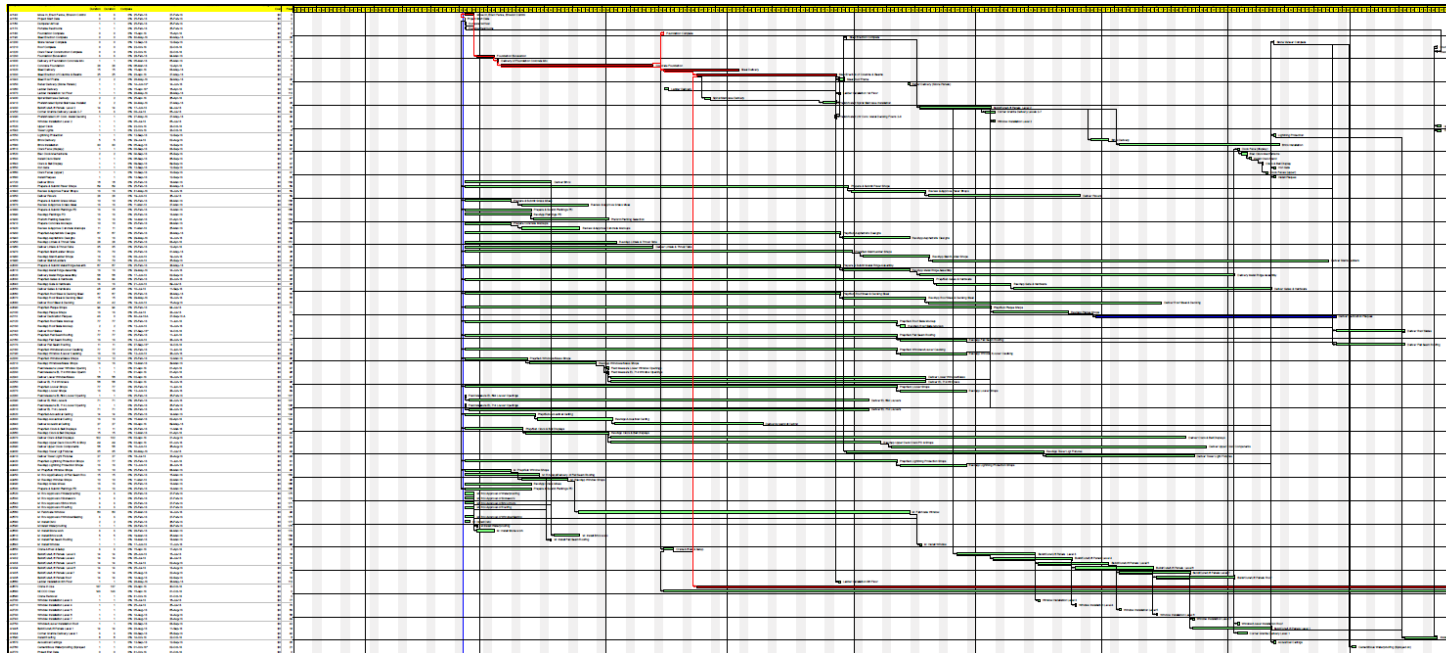

# Appendix N – Proposal

## Table of Contents

Abstract.....	ii
Table of Contents.....	iii
Table of Figures.....	iv
1.0 Introduction.....	1
2.0 Background.....	3
2.1 History of the Worcester Insane Asylum.....	3
2.2 DCAMM.....	6
2.3 Costello Dismantling.....	7
2.4 Collaboration Award at the 2013 World Demolition Awards for this project.....	10
2.5 Gilbane Construction.....	11
2.6 Ellenzweig.....	12
2.7 Construction Project Management.....	13
2.7.1 Filed Sub-Bid System.....	14
2.7.2 Construction Management.....	14
3.0 Methodology.....	15
4.0 References.....	18



## Table of Figures

Figure 1: Insane Hospital, Worcester, Mass. 1906 postcard.....	4
Figure 2: Map of New and Historical Buildings.....	5
Figure 3: Costello dismantling the Clock Tower.....	8
Figure 4: Dan Costello accepting Collaboration Award.....	10
Figure 5: Gilbane’s progress of Construction on the Tower.....	12

## 1.0 Introduction

In 1833 the grand opening of the Worcester Insane Asylum was opened for the care of mentally ill patients. The centerpiece of the asylum was a massive clock tower that rose up from the administrative building. Officially closing in the early 1990's the asylum was closed down and demolition on the site began. The administrative building was scheduled to be preserved with the famous clock tower. Unfortunately, in 1991 the building caught fire and after significant structural damage done on the building it was determined to be structurally deficient. The desire to preserve the building was outweighed by the need to prevent a dangerous collapse (Costello 2013). It was decided the building would be dismantled and the tower would be rebuilt on the site in honor of the massive role Worcester played in the treatment of mental health over the past 180 years in the United States of America (McGovern 2012).

The three major project participants are the owner, Division of Capital Asset Management and Maintenance (DCAMM), the construction manager, Gilbane, and the dismantling company, Costello. The Dismantling required the top of the tower to be taken apart piece by piece of stone by hand, photographing, and numbering so that it could be restored as a part of the new tower. With the tower being so high the city of Worcester fire department was on standby for the dismantling ready to perform an aerial rescue at any moment. The demolition was completed in March of 2013 with no accidents. On October 31<sup>st</sup>, Costello Dismantling won the Collaboration Award at the 2013 World Demolition Awards for this project.

Gilbane Construction is responsible for the building of the new clock tower that is going to be built in honor of replacing the famous one that stood for so many years. Gilbane hired Structures North as the engineers to design the tower with the help of Ellenzweig architects and Preservation Worcester. The design was created to replicate the old tower with the top of it having the same exact stone that was present on the original tower. The engineers at Structures

North designed the tower completely of reinforced concrete. Since the old building only had the top of the tower rise out of it, the architects and Preservation Worcester worked together to come up with a similar look through the bottom part of the structure allowing the tower to maintain the Victorian-Era look.

The goal of this study is to make an alternative design to the tower that is being done by Gilbane Construction. Extensive analysis of the schedule and cost estimations done by Gilbane will be reviewed and re-adjusted to the proposed alternative design.

The current structural design is a tower made of reinforced concrete. The proposed alternative design will be made of a steel frame to replicate the Worcester Memorial Clock Tower as wanted by Preservation Worcester. Changing from reinforced concrete to a steel frame structure will present new challenges in how the existing stone from the old clock tower will be attached to the structure. As well the study will show changes in cost and scheduling as concrete and steel projects run completely differently and will determine what design is more beneficial for the project. The proposed alternative design will be built and made visualized in 3D model using Autodesk Revit. Once the model is completed it will be imported into RISA-2D where structural analysis will be performed on the structure to see how the design works. Additional design work that will be needed for the attaching of the stone, or other individual member sizing will be performed by hand following ASCE code. From a project management standpoint the alternative design will be cost estimated and scheduled including each activity using Primavera. The project will be compared to the original schedule and cost estimation of Gilbane's tower to determine if the alternative design will be more beneficial to the owners (DCAMM).

## 2.0 Background

### 2.1 History of the Worcester Insane Asylum

The Worcester State Hospital first opened on January 12, 1833, and was originally named the Worcester Lunatic Asylum. This was the first building to provide for the mentally insane in the state of Massachusetts. Within the first several years of opening overcrowding started to become a serious issue which needed to be addressed (Asylum Projects). Despite the necessity for new space and funds, the state legislature did not provide a solution for the Worcester Lunatic Asylum until 1869, when a tract of land near the edge of the city was purchased to build a new building complex.

This new building structure would follow the Kirkbride Plan; having a central administration building with staggered wings stemming from both sides (Opacity). This particular building style became very popular in the nineteenth century when planning for the treatment of the mentally ill within the United States. The structure was believed to place patients in a natural environment with abundant fresh air and natural light which would contribute to a healthy environment and a more jovial atmosphere (Kirkbride, 2008). Construction of the Kirkbride building began in 1873 and was designed by architect George Dutton Rand of Weston and Rand. After three years of construction, in 1877, the flagstone and brick building, standing four stories tall was completed with a gothic clock tower building as a part of the central administration building (Opacity).



Figure 1: Insane Hospital, Worcester, Mass. 1906 postcard

Over the next seventy years, the Kirkbride building provided adequate space for the patients. In the 1950's, the number of patients and staff reached about three thousand and to relieve overcrowding again, another structure named the Bryan Building was erected on campus. This building provided a more modern environment for the treatment of the mentally ill. During the 1960's, when deinstitutionalization movements took hold, many patients were moved out of the outdated Kirkbride building leaving it somewhat empty during the 1980's (Opacity). On July 22<sup>nd</sup> 1991, a massive fire engulfed the Kirkbride building, destroying almost all of the roofs and floors along most of the building besides the Clock Tower building. After this fire, the Kirkbride was no longer considered structurally safe, the building was closed and left vacant. In 2006, the site was selected as the location for a new mental health facility.



Figure 2: Map of New and Historical Buildings

After the fire, the remains of the 19<sup>th</sup> century Victorian hospital complex and Clock Tower made it onto Preservation Worcester's Most Endangered Structures List in 1995. Preservation Worcester is a not-for-profit membership organization whose mission is to; "Preserve for future generations the sites and structures which are significant to the culture, history, and architecture of the city and to encourage excellence in future design" (Preservation Worcester). The organization has advocated for the preservation of the Worcester State Hospital and Clock Tower and has had the building on the Most Endangered Structures List seven times from 1991-2011; in 2010 it was also named to the Endangered List of Massachusetts. Since 2006, when the site was selected for a new mental health facility location, Preservation Worcester, the Worcester Historical Commission, the Massachusetts Historical Commission, representatives of the City of Worcester, and concerned local citizens have been working with the Massachusetts Department of Capital Assessment Management and Maintenance (DCAMM) and the Department of Mental Health (DMH) to assure the preservation of the Clock Tower and the Hooper Turret (Preservation W). Without the dedication of the Preservation Worcester and the other organizations, the buildings that remained from the fire would have been demolished to

make way for the new health facility and that piece of Worcester history would have been lost forever.

## 2.2 DCAMM

Administration and Finance (A&F) is the Massachusetts Executive office that is committed to building a better Commonwealth for the community. The Division of Capital Asset Management and Maintenance (DCAMM) is an agency within this office that is responsible for integrated facilities management, major public building construction, and dealing with real estate services for Massachusetts. This agency was founded in 1980 by the Legislature in order to promote quality and integrity in the management and construction of the Commonwealth's capital and real estate assets (Commonwealth of Massachusetts, 2014).

DCAMM manages 5.5 million square feet of state building with millions more to become under management within the upcoming years. DCAMM is used to assist their client agencies using comprehensive and cost-effective maintenance and management strategies and standards (Commonwealth of Massachusetts, 2014). Their projects go from a wide variety of construction to renovation and repairs of structures such as academic buildings, courthouses, correctional facilities, and recreational facilities. "DCAMM is proud to be able to facilitate honoring the long standing history of public mental health care in the Commonwealth through our participation in the design and construction of this memorial clock tower," said Division of Capital Asset management Commissioner Carole Cornelison.

## 2.3 Costello Dismantling

Costello Dismantling is a family run business that is best known for their attention to safety. Dan Costello founded and incorporated the company in 1985 and their headquarters can

be located in West Wareham, Massachusetts. The company now makes an average annual revenue of \$6,800,000 and employs a staff of approximately 50 workers. The company makes this money by reselling the scrap materials such as metals and wood. In some cases the resale value of some metals far exceeds the cost of the demolition. It is on jobs like this where Costello has to pay the owner of the building for the right to tear it down and scrap it. Some of Costello's jobs have produced more than \$1 million in proceeds from salvage. The demolition several years ago of a 19th-century textile mill in New Bedford, Massachusetts, yielded more than \$300,000 for the wood alone. This wood was carefully preserved Southern yellow pine that was sold to different sawmills to be turned into flooring. Shredded scrap steel recently have sold for nearly \$400 per ton (The Wall Street Journal, 2012). Other projects That Costello Dismantling Inc. have been a part of are the Newton North High School, Plymouth Cordage Mill, Massachusetts General Hospital, Taunton State Hospital, and many more.

The desire to preserve the tower as it was showed to be too great due to the fire damages it received in 1991. So a decision was made to deconstruct and reassemble the clock tower on site. This project is estimated to cost about \$300 million dollars. The Massachusetts Department of Capital Asset Management and Maintenance (DCAMM) hired Gilbane as General Contractor and Construction Manager in order for them to supervise this project. Costello Dismantling collaborated with DCAMM and Gilbane in order to create a work plan in order to deal with the dismantling and construction adjacent to an occupied hospital. The team employed over 20 contractors which included engineers, health and safety professionals, masonry restoration workers, clock repair specialists, and environmental protectors.





Figure 3: Costello dismantling the Clock Tower

The deconstruction of the tower proved to be a long and painstaking process. The process involved the removal of each stone by hand, numbering, photographing, and then cataloging each in order that the stones could be put back in the same place when the tower was erected. The deconstruction team consisted of a crew of 17 masons, 13 environmental professionals, 15 demolition specialists, 2 engineers, and 4 full-time safety officers. It is with this crew that the dismantling of the tower was able to go injury free even with working at dangerous heights. Dealing with the height of the tower was the main problem the crew had to deal with. The dismantling crew used 150 foot tall boom lifts and man baskets suspended from cranes in order to reach the top of the 135 foot tower. If a mechanical failure were to it would leave the worker stranded in this man basket. In order to compensate for this there we always two lifts on the jobsite that were capable of rescuing a stranded worker at any height. To go along with

these safety cranes there was also a specially trained Aerial Rescue Team that would know exactly what to do in a situation of a necessary rescue. There was actually one incident where a worker did become stranded and need saving due to mechanical failure, but he was successfully rescued with zero time loss from the incident. Another way Costello dealt with the hazardous job site was a falling debris engineer was hired to study the jobsite. This engineer studied the tower and located the potential fall zone of debris from the building of a radius about 40% of the building's height.

The demolition of the tower was completed in March, 2013 with over 13,000 man-hours put into the deconstruction, remediation, and dismantling. All of these work hours resulted in zero loss time accidents. This was achieved by the collaborative work between Costello Dismantling, Gilbane, and DCAMM. On October 31<sup>st</sup>, Costello won the annual

#### 2.4 Collaboration Award at the 2013 World Demolition Awards for this project



Figure 4: Dan Costello accepting Collaboration Award

The World Demolition Summit has been meeting annually since 2009. This is an international convention of Contractors who are involved in the demolition equipment industry. The summit has met at the Krasnapolsky Grand Hotel in Amsterdam, Netherlands since its first convention in 2009. Each year the summit gives ten different awards including: The Manufacturer's Innovation Award, Explosive Demolition Award, Recycling and Environmental Award, Safety and Training Award, and Contractor of the Year Award. The Collaboration Award was awarded to Costello for their high degree of collaboration from all parties involved, demolition contractor, main coordinator, client etc. Statements and information were required from all participating parties and such entries needed to show clear levels of collaboration achieved and the individual's view of success generated from the collaboration (KHL, 2008).

## **2.5 Gilbane Construction**

Gilbane Construction, which is based in Providence, Rhode Island, was founded in 1873 by the two brothers William and Thomas Gilbane. They started by building homes in Providence, but new projects such as churches, hospitals and other public buildings quickly followed. During the early 1900's Gilbane was able to survive through the Great Depression due to being known as the pioneers in construction management. They received this reputation by working on major defense projects during World War II and also working on the Smithsonian's National Air and Space Museum.

Today Gilbane Construction is led by the fourth-generation members of the family with more than 25 offices located across the United States. During the past two decades Gilbane has completed a plethora of acknowledgeable projects such as the Lake Placid Winter Olympics Facilities, Vietnam Veterans Memorial, U.S Department of Justice, World War II Memorial, and many more. The company makes an estimated revenue value of \$2.83 Billion and are

employing approximately 2,000 American workers. Also Gilbane is ranked 14<sup>th</sup> in the 2014 Engineering News Record's Top 400 Contractors which is an improvement from being ranked 21<sup>st</sup> in the 2013 charts (The Top 400 Contractors, 2014). The Department of Mental Health has hired Gilbane Building Company as the Construction Managers.



Figure 5: Gilbane's progress of Construction on the Tower

## 2.6 Ellenzweig

Ellenzweig was founded in 1965 and is a national architectural firm with its office located in Cambridge, Massachusetts. This firm specializes in master planning, programming, feasibility study, in-house laboratory planning, and architectural design services. The company uses a combination of Revit Architecture, AutoCad, and SketchUp in order to perform the visualization,

planning, and designing of the wide range of buildings they have for projects. In order to help with streamlining and coordinating the project delivery process for each client, Ellenzweig uses the software known as Building Information Modeling (BIM). This software is not only able to analyze the geometry of the building, but also the spatial relationships, light analysis, geographic information, and quantities and properties of building components. Some notable project locations done by this firm are at Massachusetts Institute of Technology in 1998, Harvard University in 2001, and University of Massachusetts in 2004. Ellenzweig are the architects hired by DCAMM in order provide their expertise in programming, site analysis, design of the new facility, and eventually the construction administration services on the jobsite.

## **2.7 Construction Project Management**

Construction Project Management (CPM) is the overall planning and coordination of a project from beginning to completion. The principle focus of CPM is the management of civil engineering projects including planning, scheduling, organization and control, as well as management concepts of leadership, motivation, trust, project team development, division of work, and conflict resolution. Ancillary engineering and construction practices involving financial practices, construction documents, contract negotiation and administration, quality and safety control, insurance and bonding are covered. Emphasis is given to Fundamental Engineering Economics and Risk Analysis to efficiently produce an estimation of time and cost.

### **2.7.1 Filed Sub-Bid System**

Major construction projects usually involve multiple subcontractors working under the General Contractor. In the State of Massachusetts, General Laws require the “filed sub-bid” system for selecting certain subcontractors on many public building construction projects. This Law requires contractors to submit their bids in two phases. These Construction Bids are proposals to manage the undertaking of a particular construction project, beginning with a cost estimate and blueprints. Being that the Clock Tower restoration is a public building construction project, Massachusetts state law required DCAMM use the file sub-bid system. The first phase requires subcontractors to submit their bids to the Awarding Authority; DCAMM then compiles a list of sub-bids received and sends these to all general contractors interested in the project. The interested general contractors then need to submit their own bid including any file sub-bidders that will be used for the project. This system of bidding gives general contractors little control of whom they will work with (Massport).

### **2.7.2 Construction Management**

The Clock Tower is currently being built by Gilbane Construction Company using a Construction Management (CM) delivery method approach. The construction manager running the operations of the project is, Mike Forwood. With this method, Forwood is heavily involved in the design process, working with DCAMM and Ellenzweig to create the best possible project within the budget. As the construction manager, Forwood was responsible for providing a cost estimation, consultation in design, preparation of bid packages and scheduling for the entirety of the project.

## 4.0 References

[http://www.asylumprojects.org/index.php?title=Worcester\\_State\\_Hospital](http://www.asylumprojects.org/index.php?title=Worcester_State_Hospital)

[http://opacity.us/site56\\_worcester\\_state\\_hospital.htm](http://opacity.us/site56_worcester_state_hospital.htm)

Kirsch, T. (n.d.). *Worcester State Hospital History*. Retrieved September 9, 2009, from Opacity:  
[http://www.opacity.us/site56\\_worcester\\_state\\_hospital.htm](http://www.opacity.us/site56_worcester_state_hospital.htm)

<http://www.kirkbridebuildings.com/about/history.html>

<http://www.kirkbridebuildings.com/forum/viewtopic.php?f=40&t=1337>

Anderson, K. (2008, August 27). *Fighting for Preservation: Worcester State Hospital and the Death of a Kirkbride*. Retrieved September 10, 2009, from Associated Content:  
[http://www.associatedcontent.com/article/970694/fighting\\_for\\_preservation\\_worcester\\_pg2\\_pg2.html?cat=62](http://www.associatedcontent.com/article/970694/fighting_for_preservation_worcester_pg2_pg2.html?cat=62)

<http://www.preservationworcester.org/documents/ClockTowerHistoryandBackgroundInfo.pdf>

<http://www.golocalworcester.com/news/breaking-deal-struck-for-worcester-state-hospital-clock-tower>

Friday, February 17, 2012

Meghan Ottolini, GoLocalWorcester Contributor

Gilbane Inc. History. (n.d.). from Gilbane Co.:

<http://www.gilbaneco.com/history.html>

Hager, James R. (Dec. 22, 2012) *The Wall Street Journal*

<http://online.wsj.com/news/articles/SB10001424127887323723104578185524187191846>

The Top 400 Contractors, 2014

<http://enr.construction.com/toplists/Top-Contractors/001-100.asp>

<http://www.khl-group.com/events/demolition-summit-2014/2013.html#winner2013>

<http://www.khl.com/events/ds2012/how-to-enter/>

[https://www.massport.com/media/1130/c\\_instruction\\_ex17.pdf](https://www.massport.com/media/1130/c_instruction_ex17.pdf)

[http://www.costelldismantling.com/pages/cfProjects\\_Details.cfm?ProjectID=48](http://www.costelldismantling.com/pages/cfProjects_Details.cfm?ProjectID=48)

<http://www.a-p.com/service/delivery-methods>



## Appendix O – Electronic Files

1. Robot File – *Robot File.rbt*
2. Work Packages – *Work Package.xlsx*
3. Primavera Schedule – *Primavera Schedule.xer*
4. SAP File – *clock tower sap.>k*
5. Mat Foundation – *Mat Foundation.rbt*
6. Revit Model – *Revit*