

April 2013

Haptic Feedback for Transesophageal Echocardiogram Transducer

Bangyan Zhang
Worcester Polytechnic Institute

Ben Sancetta
Worcester Polytechnic Institute

Daniel Thomas Nahill
Worcester Polytechnic Institute

Follow this and additional works at: <https://digitalcommons.wpi.edu/mqp-all>

Repository Citation

Zhang, B., Sancetta, B., & Nahill, D. T. (2013). *Haptic Feedback for Transesophageal Echocardiogram Transducer*. Retrieved from <https://digitalcommons.wpi.edu/mqp-all/3472>

This Unrestricted is brought to you for free and open access by the Major Qualifying Projects at Digital WPI. It has been accepted for inclusion in Major Qualifying Projects (All Years) by an authorized administrator of Digital WPI. For more information, please contact digitalwpi@wpi.edu.

Haptic Feedback for Transesophageal Echocardiogram Transducer

A Major Qualifying Project

Submitted to the Faculty of the

WORCESTER POLYTECHNIC INSTITUTE

in partial fulfillment of the requirements for the

Degree of Bachelor of Science

in Mechanical Engineering

By

Daniel Nahill

Ben Sancetta

Bangyan Zhang

Date: April 26, 2012

Approved:

Keywords

1. Transducer
2. TEE
3. Haptic Feedback

Professor Allen H. Hoffman, Major Advisor

Professor Holly K. Ault, Co-Advisor

Abstract

This project focused on developing a haptic feedback control system for a transesophageal echocardiogram probe. The project group researched current haptic technologies available today to create feasible design ideas while focusing on combining simplicity, efficiency, and reliability. A customized haptic feedback sensor system was then designed for our application and a 3D model was developed. The project group built a functional prototype using a combination of self-manufactured parts and parts from several suppliers. Test procedures were then designed and implemented to prove the prototype's functionality.

Table of Contents

Abstract	ii
List of Figures	vii
List of Tables	x
Chapter 1: Introduction	1
Chapter 2: Background	2
2.1 TEE Probes.....	2
2.1.1 X7-2t TEE Probe.....	3
2.2 Procedures	5
2.3 Haptic Feedback.....	6
2.4 Sensors.....	9
2.4.1 Force Sensitive Resistor	9
2.4.2 Torque sensor	10
2.4.3 Tension Sensor	11
2.4.4 Strain Gauges	12
2.5 Drive System	13
2.5.1 Servo Motors.....	13
2.5.2 Linear Actuators.....	14
2.6 Microcontroller	15
Chapter 3: Project Objective.....	17
3.1 Problem Statement.....	17
3.2 Goal Statement	18
3.3 Design Specifications	18
3.3.1 Entire System	19
3.3.2 Sensors.....	19
3.3.3 Drive Mechanism	19

3.3.4 Microcontroller	20
3.3.5 User Interface.....	20
Chapter 4: Preliminary Designs and Zeroth Order Prototyping.....	21
4.1 Sensors	21
4.1.1 Force Sensitive	21
4.1.2 Tension Sensor	22
4.1.3 Torque Sensor	23
4.2 Drive Systems.....	24
4.2.1 Existing Rack and Pinion.....	24
4.2.2 Linear Actuator	25
4.2.3 Motor with Spool Attachment	27
4.3 User Interface	28
4.3.1 Force Feedback Steering Wheel	28
4.3.2 Joystick	28
4.3.3 Conventional Game Controller	29
4.3.4 Keypad.....	30
4.4 Zeroth Order Prototype	30
4.4.1 Gear Sensor Design	31
4.4.2 Finite Element Analysis	32
4.4.3 Construction, Testing, and Results.....	32
Chapter 5: Selection of Final Design	33
5.1 Pairwise Charts.....	34
5.2 Decision Matrices.....	35
5.3 Selection of Final Design	36
Chapter 6: Prototype Design and Manufacturing.....	37
6.1 Circuit Design	39

6.2 Program Design	42
6.3 Housing Design.....	42
6.4 Adapter	44
6.2 Prototype Manufacturing	46
6.2.1 Gear Sensor	46
6.2.2 Housing	46
6.2.3 Adapter	47
6.2.4 Circuit Construction	47
Chapter 7: Testing and Results	48
7.1 Testing.....	48
7.1.1 Determine Maximum Safe Torque.....	48
7.1.2 Correlation between Sensor Value and Torque.....	50
7.1.3 Sensor Calibration	53
7.1.4 Tip Displacement Test.....	55
7.2 Results.....	56
Chapter 8: Discussion.....	56
Chapter 9: Recommendations	58
9.1 Housing Recommendations	58
9.2 Circuit Board Improvements.....	58
9.3 User Interface Improvements.....	59
9.4 Gear Sensor Recommendations.....	59
Chapter 10: Conclusions	60
References	61
Appendix A: Finite Element Analysis.....	64
Appendix B: Programming Code	70
Appendix C: Determining Maximum Safe Torque	78

Appendix D: Correlation between Sensor Value and Torque	84
Appendix E: Sensor Calibration and Testing	85
Appendix F: TEE Tip Displacement Testing	86

List of Figures

Figure 1: This image shows various TEE probes manufactured by Phillips Electronics. (Koninklijke Phillips Electronics N.V., 2012).	2
Figure 2: The complete TEE imaging system. Highlights Key features such as the distal end of the probe (30), the control for maneuvering the distal end (30), the image display (24), and the processing CPU (20).	3
Figure 3: Schematic from US Patent 7588536 B2 illustrating top view of TEE control.	4
Figure 4: Schematic from US Patent 7588536 B2 illustrating side view of TEE control.	5
Figure 5: Flow chart illustrating the various steps of a haptic system loop (Kern, 2009, p.105).	7
Figure 6: Human Haptic Information. (Kern, Engineering Haptic Devices).....	9
Figure 7: This image shows the relative size of the Interlink 402 FSR, a potential solution for the modified TEE probe application. (Adafruit Learning System)	10
Figure 8: Force-Resistance Relationship of Interlink 402 FSR (Adafruit Learning System).....	10
Figure 9: SCHMIDT LTS-422 Tension Sensor (SCHMIDT Control Instruments).....	11
Figure 10: Illustrates a tension sensor actively measuring the tension of a wire holding a weight (Schmidt-Tension Meter Calibration, 2013).	12
Figure 11: Degrees of Freedom.....	13
Figure 12: Hi-Tec HS-7975HB Servo (RCD)	14
Figure 13: Traveling-nut linear actuator (The Bug).....	15
Figure 14: TI MSP430F449 Microcontroller (Texas Instruments)	16
Figure 15: Left, Front, and Right views of Force sensitive resistor initial design.....	22
Figure 16: Tension Sensor Design	22
Figure 17: Design of torque sensor system.....	23
Figure 18: Torque sensor example.....	24
Figure 19: Illustrates a design using the existing TEE probe's rack and pinion. Gears are mounted where previous hand controls once existed and are driven by servomotors.	24
Figure 20: Shows an example of a worm gear configuration. Worm gears provide maximum torque and precision, all while nearly eliminating the concerns of back-drive.....	25
Figure 21: This image displays the design concept for using linear actuators. 4 Linear actuators attached to each of the tip control wire move equally and oppositely in a pair to operate the heave and sway degrees of freedom.	26
Figure 22: This image designates the degrees of freedom, which would be controlled by actuators.....	26

Figure 23: Illustrates how wrapping connected spools in alternating directions would allow one wire to be pulled in while letting another out.	27
Figure 24: Image on the left shows the motor and spool assembly. Image on the right shows the overall design concept.	27
Figure 25: Force feedback steering wheel	28
Figure 26: Joystick system.....	29
Figure 27: Xbox Controller	30
Figure 28: Keyboard with LEDs	30
Figure 29: Zeroth order prototype gear sensor	31
Figure 30: Finite element analysis of gear sensor to determine strain	32
Figure 31: Completed torque sensor	33
Figure 32: Block diagram of final prototype design.....	37
Figure 33: Photo of final prototype with all parts labeled.....	38
Figure 34: Block diagram final circuit design	39
Figure 35: Bread board 1 circuit design	40
Figure 36: LED Feedback System Circuit Design	40
Figure 37: Bread board 2 circuit design	41
Figure 38: Arduino pin usage diagram.....	41
Figure 39: Final housing design.....	43
Figure 40: Motor cradle	44
Figure 41: TEE Cradle	44
Figure 42: Round horn included with servo.....	45
Figure 43: Gear sensor to servo horn adapter.....	45
Figure 44: Gear sensor to servo horn adapter assembly.....	45
Figure 45: Gear sensor used in the final prototype	46
Figure 46: Image showing two of the adapters mounted on the prototype assembly.....	47
Figure 47: Modified TEE Detailing the Two Sensors	51
Figure 48: Graph of sensor 1 test without slip clutch enabled.....	51
Figure 49: Graph of sensor 1 test with the slip clutch enabled	52
Figure 50: Graph of sensor 1 test with hand	53
Figure 51: Displacement test of original TEE CCW yaw	55
Figure 52: Displacement test of modified TEE CCW yaw.....	55

Figure 53: Toolbox Gear	64
Figure 54: Spoked Gear (Left) and Detail of Curve (Right).....	65
Figure 55: Cylindrical Constraints	65
Figure 56: Tooth Constraint	66
Figure 57: Loading.....	66
Figure 58: Strain, E=200ksi.....	67
Figure 59: Strain, E=300ksi.....	67
Figure 60: Stress, E=200ksi.....	68
Figure 61: Stress, E=300ksi.....	68
Figure 62: Stress Analysis Model for FEM Verification	69
Figure 63: Materials needed for experiment include a TEE probe, duct tape, (2) 6" string, and a 5 lb. force gauge.	79
Figure 64: Illustrates the "on" position for the safety slip clutch.	79
Figure 65: Strings should be attached to each force gauge as shown.....	80
Figure 66: Measuring the distance from the center of the large knob to the string tie. String should be carefully secured at measured distance with duct tape.....	80
Figure 67: Measuring the distance from the center of the small knob to the string tie. String should be carefully secured at measured distance with duct tape.....	81
Figure 68: Illustrates measuring the safe torque value for large knob. Notice string is pulled tangentially to knob.....	81
Figure 69: Illustrates measuring the safe torque value for small knob. Notice string is pulled tangentially to knob.....	82
Figure 70: Displacement test of original TEE CCW yaw	87
Figure 71: Displacement test of modified TEE CCW yaw.....	87
Figure 72: Displacement test of original TEE CW yaw	88
Figure 73: Displacement test of modified TEE CW yaw.....	88
Figure 74: Displacement test of original TEE CCW pitch.....	88
Figure 75: Second image of displacement test of original TEE CCW pitch	89
Figure 76: Displacement test of modified TEE CCW pitch	89
Figure 77: Displacement test of original TEE CW pitch.....	89
Figure 78: Displacement test of modified TEE CCW pitch	90

List of Tables

Table 1: Entire System Pairwise Chart	34
Table 2: Sensors Pairwise Chart	34
Table 3: Drive Mechanism Pairwise Chart	34
Table 4: User Interface Pairwise Chart	35
Table 5: Sensors Decision Matrix	35
Table 6: Drive Mechanism Decision Matrix	35
Table 7: User Interface Decision Matrix.....	36
Table 8: Force and torque results for the small knob of the TEE probe.....	49
Table 9 : Force and torque results for the large knob of the TEE probe.	50
Table 10: Sensor 1 calibration table	54
Table 11: Sensor 2 calibration table	54
Table 12: Force and torque results for the small knob of the TEE probe.....	83
Table 13 : Force and torque results for the large knob of the TEE probe.	83

Chapter 1: Introduction

Heart disease is the leading cause of death in the United States according to the most recent data made available by the U.S. Department of Health and Human Services (Murphy, Xu, & Kochanek, 2012). Early diagnosis for heart disease is critical to increasing the survival rates of heart disease victims. Many tests and procedures have been developed in order to diagnose heart conditions with one of the increasingly popular procedures being the echocardiogram. The procedure has gained popularity due to advances in technology that make it extremely accurate in diagnosis with minimal invasiveness and pain to the patient.

Traditionally an echocardiogram has consisted of strategically placing ultrasound transducers on the patient's chest and using the ultrasound to produce images of the patient's heart. The drawback of the standard echocardiogram is that in order to obtain the heart images, the ultrasound must travel through fatty tissue and bone, which can vary between patients (Stanford Hospital & Clinics). This problem was answered in the late 1960s with the invention of the Transesophageal Echocardiogram (TEE). This particular procedure involves inserting the transducer probe into the esophagus rather than placing the transducers on the chest (Stanford Hospital & Clinics). Images taken by the TEE procedure result in clearer pictures since the bones and fatty tissue no longer block the transducer from the heart. Additionally, recent technological advances of the TEE probe allow for transducers to take 3D images of the heart increasing the resolution of images and reducing the need for supplementary X-ray imaging (University of California San Francisco).

The current design of the TEE transducer probe doesn't permit the interventional cardiologist to maneuver the transducer to the desired position while in the esophagus. Instead, the probe is maneuvered by an echocardiologist working in conjunction with the interventional cardiologist. Placing the TEE transducer controls directly in the hands of the interventional cardiologist would not only increase efficiency of the procedure, but also decrease costs associated with scheduling the echocardiologist. Extending the existing controls to the interventional echocardiologist would substantially lengthen the TEE probe's existing mechanical linkages resulting in a dangerous reduction of precision. Controlling the current controls with motors in conjunction with a sensor system offers a possibility to extend control while simulating the necessary tactile feedback. This project focuses on investigating a method of relaying the TEE probe tip's tactile forces to the user when it is operated using electric motors.

Chapter 2: Background

Chapter 2 provides information to aid the reader's understanding of this project. General information about TEE probes, patent explanation of probes, and a walkthrough of a TEE procedure can all be found this chapter. This chapter also provides information on the technology that was researched and used in this particular project. These technologies include several types of sensors, servomotors, linear actuators, and microcontrollers.

2.1 TEE Probes

In order to image the heart in a TEE procedure, an ultra sound transducer has to be maneuvered into the esophagus of the patient. This transducer must maintain firm contact against the esophageal wall for optimal image resolution. The face of the transducer window will need to be manipulated to orient the ultrasound imaging towards the area of interest (Peszynski, 2012). Insertion and maneuvering of the transducer is attained using a TEE probe (Figure 1).



Figure 1: This image shows various TEE probes manufactured by Phillips Electronics. (Koninklijke Phillips Electronics N.V., 2012).

There are several types TEE probes available on the market today. The first and most basic echocardiogram is known as the M-Type. The M-Type echocardiography displays outlines of the heart and its structures rather than images. Most often this type is utilized when measuring the heart and its structures. Doppler echocardiography is a specialized echocardiogram that employs the Doppler effect to calculate blood flow in and around the heart. This technique is extremely useful when searching for abnormalities in blood flow or dysfunctional valves. Color Doppler is an extension of the Doppler echocardiography that applies color gradients to the blood to contrast different blood flows. Two-dimensional (2-D) echocardiography permits cardiologists to view real-time imaging of active heart

structures. The introduction of three-dimensional (3-D) echocardiography enables higher resolution images of the heart than 2-D echocardiograms could achieve, allowing doctors to pinpoint abnormalities with greater accuracy than earlier TEE methods (Johns Hopkins Hospital).

2.1.1 X7-2t TEE Probe

The designs and prototype in this particular project will use the X7-2t, a TEE three-dimensional echocardiogram probe produced by Phillips Electrical [Figure 2]. This device contains both a 2-D and 3-D matrix array permitting the device to create a multitude of different image types. These image types include; 2-D, Color Flow, PW Doppler, CW Doppler, M-Mode, Live xPlane imaging, Live 3-D Echo, Live 3-D zoom, advanced XRES, triggered full volume, and triggered 3-D color. Phillips also specifies the X7-2t TEE is designed for patients greater than 30 kg/66 lb (Koninklijke Philips Electronics N.V.).

Phillip's X7-2t TEE probe is a very complicated system that is described by multiple patents. The first patent, patent number 6572547 B2, details a "semi-invasive ultrasound imaging system for imaging biological tissue". The patent explains the device includes "a transesophageal probe connected to a two-dimensional transducer array, a transmit beam former, a receive beam former, and an image generator". Details of the device are depicted in Figure 2.

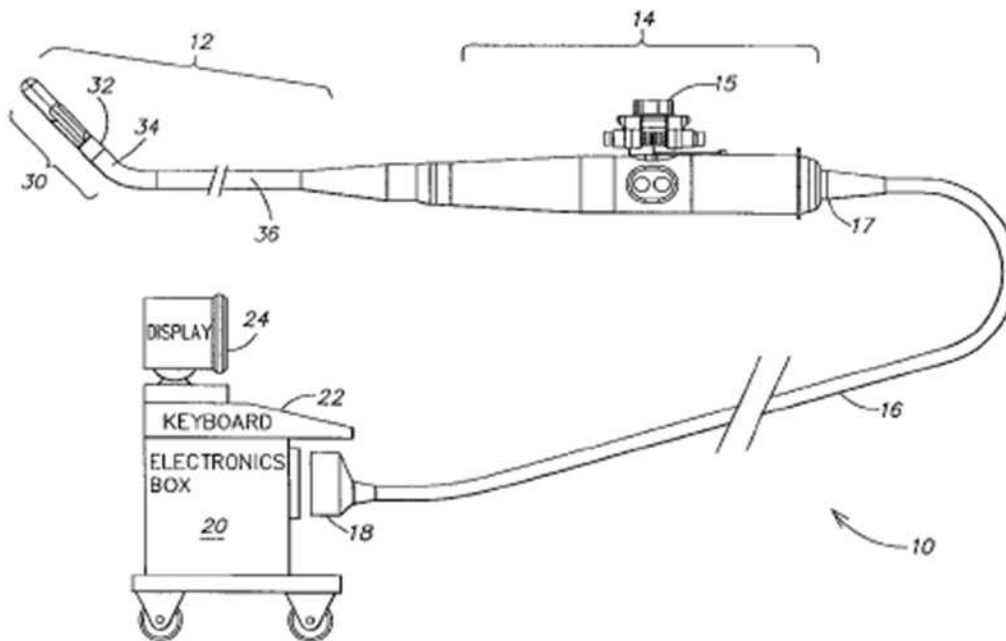

Figure 2: The complete TEE imaging system. Highlights Key features such as the distal end of the probe (30), the control for maneuvering the distal end (30), the image display (24), and the processing CPU (20).

In addition to the previous patent mentioned, Patent 7588536 B2 goes into detail on the mechanism that controls the distal end of the TEE's motion. The abstract provides excellent insight into how the X7-2t control system functions and has been provided to elaborate on its function:

“Control mechanism (10) for an endoscope including first and second independently rotatable control knobs (18,20), an inner pinion shaft (22) fixed to the first control knob (18), an outer pinion shaft (28), fixed to the second control knob (20) and coaxial with the inner shaft (22), and an intermediate shaft (34) arranged at least partially inside of the outer shaft (28) and at least partially around the inner shaft (22). O-Rings (42,46) between the intermediate shaft (34) and the inner and outer shafts (22,28) seal the interior of the endoscope and transfer torque from the inner or outer shaft (22,28) to the intermediate shaft (34), which is grounded against rotation and therefore does not transfer torque to the other shaft (22, 28). A non-cross-coupling control mechanism is achieved in which the rotation of one control knob and its associated shaft does not have any effect on the other control knob and associated shaft.”

The numbers in the abstract above refer to certain parts illustrated in the US Patent 7588536 B2 that are illustrated in Figure 3 and Figure 4.

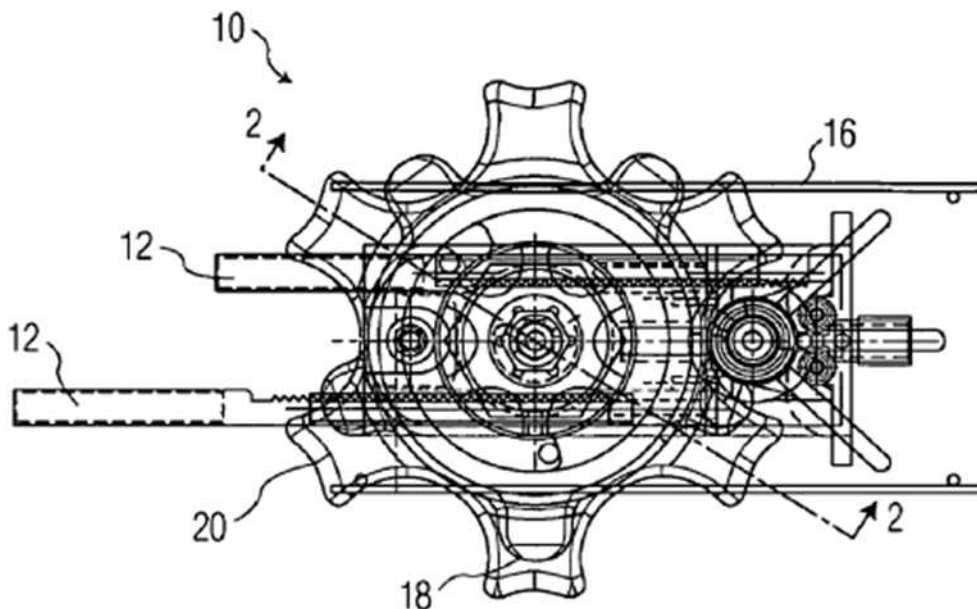

Figure 3: Schematic from US Patent 7588536 B2 illustrating top view of TEE control.

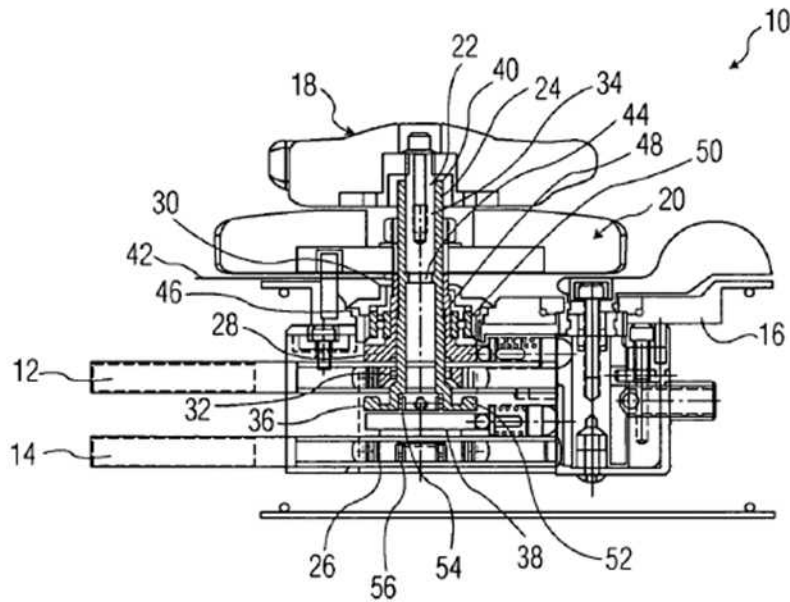

Figure 4: Schematic from US Patent 7588536 B2 illustrating side view of TEE control.

2.2 Procedures

The TEE procedure is useful to diagnose various heart related symptoms and determine certain conditions a patient may be suffering from. These conditions are typically, but not limited to; Atherosclerosis, Cardiomyopathy, Congenital Heart Disease, Congestive Heart Failure, Aneurysm, Valvular Heart Disease, Cardiac Tumor, Pericarditis, Ineffective Endocarditis (Johns Hopkins Hospital). The procedures for diagnosing these conditions are fairly similar with minor adjustments depending on the patient and the images the interventional cardiologist is attempting to capture.

Before a patient is to undergo a TEE procedure a patient is given a specific instructions on what they are allowed to do 24 hours before the exam. Doctors will require that patients fast before the procedure and will review a patient's previous ailments/conditions that may affect the test. At the start of the exam the patient is required to remove anything that may interfere with the ultrasound and will possibly be administered a sedative to relax for the duration of the exam. The patient is then required to lie on the table or bed on their left side. A local anesthetic is administered to the throat to suppress gag reflexes and make insertion of the TEE probe into the esophagus more comfortable for the patient. In some situations, the patient may be asked to swallow the TEE probe to aid insertion (Johns Hopkins Hospital). After an echocardiologist has inserted the TEE probe into the esophagus, an interventional

cardiologist will instruct the echocardiologist to maneuver the TEE probe to obtain the proper images. Upon finding the correct position for imaging, the echocardiologist is then required to hold the probe stationary for the entirety of the imaging process, only making slight adjustments according to instructions from the interventional cardiologist. It is important that the transducer window maintain good contact with esophageal wall in order for the highest resolution images possible. This means pressure must be gently applied to the probe tip to push the transducer window into contact with the esophageal wall. In certain situations the echocardiologist will be required to maneuver the TEE probe into the stomach to image the heart's underside. The interventional cardiologist will then instruct the echocardiologist to remove the probe after all of the images have been obtained (Peszynski, 2012).

There are several risks associated with the TEE procedure such as trouble breathing, heart rhythm issues, heart valve infection, scratching the esophageal wall, or worse, perforating the gastrointestinal tract. Such complications from the TEE procedure are generally rare as the procedure is considered a very safe and minimally invasive (Stanford Hospital & Clinics).

2.3 Haptic Feedback

Haptic feedback is a specific response system that uses tactile signals to communicate reactions to a user. The word haptic refers to the human sense of touch. Haptic feedback systems are particularly useful due to the immense range and variety of signals that can be given to a user. These tactile signals can include changes in texture or shape, vibrations, resistances, etc. A simple example of haptic feedback can be found in modern game controllers, which provide vibrations to users as a response to actions within the game. Haptic feedback systems come in two different classes, a time-invariant class and a time-variant class. The first class provides an unchanging haptic physical texture permitting users to distinguish the difference in texture changes. The time-variant class will change its haptic properties over time. Many existing haptic devices use a mixture of these two classes (Kern, Engineering Haptic Devices, 2009).

Haptic devices are making a substantial footprint on today's society, especially in the medical industry. The sense of touch is essential to successful medical operations such as to identify skin diseases. However, haptic technology has developed slowly due to the many technological difficulties. Rather than spend valuable time and money on developing haptic feedback technologies, companies often substitute feedback with other methods, such as visual feedback. An example of visual feedback is magnetic resonance imaging. In the medical industry, visual feedback is far from enough. New technologies such as the da Vinci robot, a robot designed to complete operations using telesurgery, lack a haptic feedback system since it focuses on minimally invasive procedures and sacrifices the space need

for a haptic feedback system. This sacrifice has led to an obvious disadvantage in using the da Vinci robot for medical surgery. The TEE procedure is very delicate and requires consistent feedback to the user. Visual feedback will not suffice this need, thus revealing the need for a haptic feedback system. (Kern, Engineering Haptic Devices, 2009).

Haptic feedback systems have three main components, a user, a haptic controller and a haptic device. The haptic device generates an output, which is perceived using the haptic controller, a component that processes and transmits haptic information to the user. Haptic interaction refers to directional transmission of haptic information. For other haptic device terms, addressability refers to the subdivision of an output signal of a device or of the user. The resolution of a haptic system refers to the capability to detect a subdivision of an input signal. A haptic marker refers to a mark communicating information about the object carrying the marker by way of a defined code of some kind (Kern, Engineering Haptic Devices, 2009).

A complete haptic system includes a haptic device, the user, interface modules, control structures, and operation process. An example system is shown in Figure 5 and illustrates the relationships and characteristics between different components of the system will be very similar to that of the TEE project.

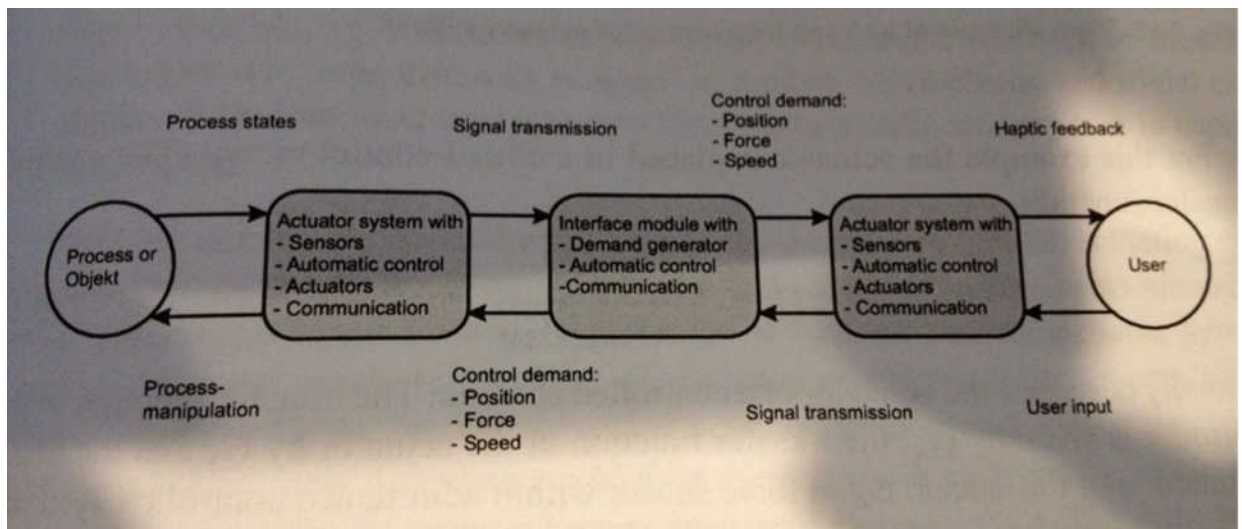

Figure 5: Flow chart illustrating the various steps of a haptic system loop (Kern, 2009, p.105).

To understand how haptic devices are controlled, the internal structures of haptic devices need to be understood. There are four types for haptic feedback systems: open-loop admittance controller system, closed-loop admittance controlled system, open-loop impedance controlled system and closed-loop impedance controlled system. The admittance controlled system focuses on receiving a force input from the user and providing a position change output. An Impedance system focuses on receiving a force output and giving a position change input. The difference between open-loop and closed-loop

systems are that in a closed loop system the output force is used as a control variable to generate the value of input force signal. In order to decide which type of systems to use, a number of parameters need to be investigated. They include a number of components, maximum impedance at slow motion, minimum impedance at fast motion, and force-resolution and impedance of mechanical components.

Generally speaking, tactile devices are more suitable to open-loop admittance controlled system.

Kinesthetic devices prefer the other three kinds of systems (Kern, Engineering Haptic Devices, 2009).

The biological and ergonomic side of haptic feedback is also very important to discuss. Human beings can sense four kinds of haptic feelings, including thermal, chemical, pain and mechanical. Haptic sense consists of many mechanical sensors that can perceive the force exerted on human tissues. These mechanical sensors can be divided into tactile sensors and kinesthetic sensors. Tactile sensors are sensors on the outside of human skins. They sense the deformation of the skin. Kinesthetic sensors are in the muscles, joints and tendons. They react to the mass, damping and stiffness changes in the human tissues. To understand the importance of force on human perception, absolute threshold and difference-limen are important concepts to be introduced here. Absolute threshold refers to the minimum value for a stimulus to be detectable in the human body. Difference-limen refers to the least noticeable difference in the change of certain stimulus to be perceivable by the human body. A table of the perceptive abilities of the human hand is shown in Figure 6. Figure 6 provides a general reference to the absolute thresholds and difference-limen of human beings.

Table 3.2 Characteristic values of the perceptive capabilities of the human hand.

Base Item	Characteristic value	Body part	Value
Static elongation / position	Skin-deformation, absolute value ^(a)	Fingertip (tactile)	10 μ m ^(b)
	Two-point threshold ^(c) (Spatial resolution)	Fingertip (tactile)	2-3 mm ^(d, e, f)
		Palm (tactile)	10-11 mm
	Position-resolution, Difference-limen (DL) ^(g)	finger joint (kinaesthetic)	2.5 $^{\circ}$
Dynamic elongations (vibration)	Frequency, upper limit (tactile perception)	Finger (tactile)	5-10 kHz
	Frequency, upper limit (kinaesthetic perc.)	whole body (kinaesthetic)	20-30 Hz
	Maximum sensitivity	Fingertip, palm (tactile)	at 200-300 Hz
	amplitude, absolute threshold	Fingertip, palm (tactile)	0.1-0.2 μ m at 200-300 Hz ^(b, i, j)
	Amplitude-resolution, difference-limen (DL) ^(g)	finger tip (tactile)	10-25 %
	Frequency-resolution, difference-limen (DL)	Fingertip (tactile)	8-10 % ^(k)
	Force and pressure	Force, absolute threshold	Fingertip ^(l) (tactile)
Palm (tactile)			1.5 mN
Force, Difference-Limen (DL)		Total body (kinaesthetic)	5-10 % (ca. 7 %) ^(m, n, o)
Pressure, Absolute threshold		Finger (tactile)	0.2 N/cm ² ^(p)
		Wrist (kinaesthetic)	4-19 % ^(q)
Torque	Difference-limen (DL)	Thumb, index finger (kinaesthetic)	12.7 % ^(r)
Elasticity	Difference-limen (DL)	Thumb, index finger (kinaesthetic)	5-15 % ^(s, t)

Figure 6: Human Haptic Information. (Kern, Engineering Haptic Devices)

2.4 Sensors

A sensor is defined as “a device that responds to a physical stimulus and transmits a resulting impulse” (Merriam-Webster dictionary, 2012). Sensors are critical parts of this project because they are responsible for measuring the force between the esophageal wall and the probe tip. The sensor is also responsible for sending the signal to the microprocessor. These operations are critical to the success of this project, and therefore dictate the need for an accurate and reliable sensor system. This section provides information about several sensor types that were analyzed to determine their potential performance in the TEE application.

2.4.1 Force Sensitive Resistor

Force sensitive resistors (FSRs) are made of materials whose electrical resistance changes depending on the amount of force applied over its measurement area. FSRs are a low cost and fairly easy to use sensor, but are not as precise as other types of sensors. An example of a FSR is the Interlink

402 model FSR (Figure 7). This figure uses a quarter as a reference to illustrate the relative size of a typical FSR.

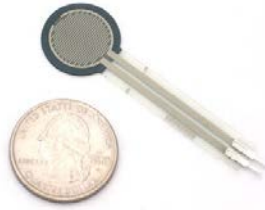

Figure 7: This image shows the relative size of the Interlink 402 FSR, a potential solution for the modified TEE probe application. (Adafruit Learning System)

Force Sensitive Resistors utilize a special design in order to change their electrical resistances based on the force exerted on them. This design incorporates three separate layers sandwiched together with small gaps of air between. When force applied to either of the two external layers, the external layers come into contact with the inner layer, decreasing the resistance. This decrease in resistance is then correlated to the force being exerted on the sensor. When there is no force applied, the FSR has almost infinite resistance (Adafruit Learning System). The relationship between the Interlink 402's resistance and the applied force is displayed graphically in Figure 8.

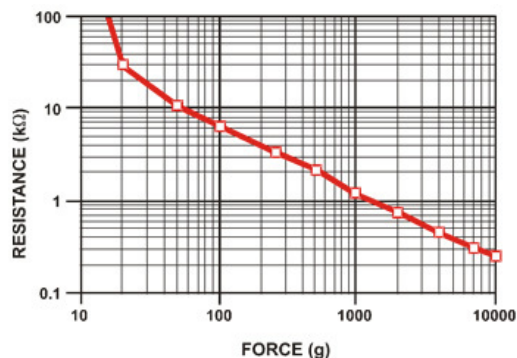

Figure 8: Force-Resistance Relationship of Interlink 402 FSR (Adafruit Learning System)

The Interlink 402 is very similar to an FSR, which could be used in the TEE prototype design. This particular model, which costs around \$7.00, has a 12.5 mm active diameter area and is .02" thick. With no applied pressure, the sensor experiences infinite resistance. Under light pressure the sensor outputs a resistance of 100 KΩ steadily decreasing till it reaches a resistance of .2KΩ at 10,000g of force. The force range for the Interlink 402 ranges from 0 to 100 Newtons applied evenly over the .125 sq. in. surface area. Additionally, the Interlink 402 operates using less than 1 mA of current.

2.4.2 Torque sensor

Torque sensors measure the torque applied to specific bodies in a mechanical system. In most cases, torque sensors are in the form of a coupler, designed to link two shafts together. This design would be preferable if motors are used to drive the rotary controls of the existing TEE probe. There are

two categories of torque sensors that exist, reaction and rotary. Reaction torque measurement means that the torqued body has little or no rotation during measurements. Rotary torque sensors are capable of measuring the torque of a revolving torqued body, such as a driveshaft. The TEE application would likely require a rotary torque sensor since the torque of the system is found in the rotary control knobs. It is worth mentioning that certain torque sensors designs can support both types of measurements (Applied Measurements LTD).

There are multiple types of torque sensors available, including magneto-elastic torque sensor, and twist angle torque sensors. Magneto-elastic torque sensors utilize permanent magnetic housings. When these housings experience torques, measurable changes in the magnetic field can be correlated to respective values of torque. Twist angle torque sensors work by measuring the rotational angular displacement of either a single torqued member or a calibrated device to determine the applied torque. Such sensors are usually mechanical and are designed to be measurement tools rather than integrated into the actual application. This type of sensor is an unlikely candidate for any TEE application.

2.4.3 Tension Sensor

A tension sensor is another consideration for this project. Most tension sensors operate under the same principles. For this application a tension gauge would be used to measure the tension in the wires that control the probe tip motion. This tension is directly related to the forces at the tip of the TEE. Measuring this tension would give an accurate representation of the forces created from interactions between the probe tip and esophageal wall. The LTS-422 tension sensor, made by SCHMIDT control instruments (Figure 9), provides an accurate representation of a typical stationary tension sensor.

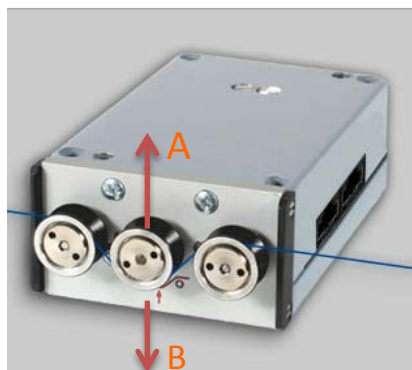

Figure 9: SCHMIDT LTS-422 Tension Sensor (SCHMIDT Control Instruments)

The sensor operates using 3 guide rollers, which can be seen on the front of the device in Figure 9. The 2 outermost guide rollers can rotate, but are otherwise stationary. The guide roller in the middle can not only rotate, but also translate up and down. When the material in tension is threaded through

the rollers, tension will cause the middle roller to translate along the axis (direction A). When tension is relaxed, the roller translates back along the axis (direction B). This displacement measurement of the middle roller can be calibrated to determine the tension within the wire.

The most crucial aspect of tension sensor selection depends on the expected tension to be encountered. However, tension sensors can readily be purchased for applications with tensions ranging from 20cN to 50daN. The Schmidt LTS-422 (Figure 10) is a good candidate for the TEE application. The maximum wire diameter size for this sensor to measure is 2 mm. The output signal of the sensor is digital RS-422 standard and able to connect any PC or processor with COM port. The tension range of this model is from 0-200N. The accuracy of this model is $\pm 2\%$ full scale and ± 1 digit or better. It has a communication frequency of 50 readings per second with a natural frequency of 500 Hz. The measuring roller deflection is 0.5mm at maximum (SCHMIDT Control Instruments).

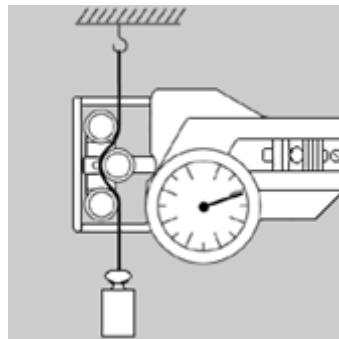

Figure 10: Illustrates a tension sensor actively measuring the tension of a wire holding a weight (Schmidt-Tension Meter Calibration, 2013).

2.4.4 Strain Gauges

A strain gauge measures the strain change of an object. Every time a force is exerted on an object, it causes stress and strain changes. Before a material reaches its yield strength, there is a linear relationship between stress and strains. For particular applications strain gauges can be calibrated to determine the stress at the location to which they are applied. A strain gauge is usually composed of a metal foil with an insulating plastic backing. It has two metal ends for electrical connection. When the gauge is strained, the resistance of the metal foil will change. This resistance change is in a linear relationship with the strain change. Through the two metal connections, a circuit can then be set up to monitor the change in its resistance. In this way, one can deduct the strain change from the resistance change. A strain gauge is usually used in a Wheatstone bridge so that one can get a stabilized and consistent reading of the strain gauge.

Strain gauges have many applications. In the case of the TEE project, strain gauges can be calibrated to measure the force change at the probe through measuring the strain change at the tip or at the driving knob (Note 15 Figure 2). As known from TEE research, a force at the tip will cause the knob end to feel the change. This change could be captured by using a strain gauge.

2.5 Drive System

The drive system controls the movement of the TEE. This drive system has to be electronically controlled to allow a feedback loop with the user interface and sensors. The drive system will control two of the four degrees of freedom that the TEE has (Figure 11). These four degrees of freedom are heave (up and down), sway (left and right), surge (forward and back) and roll (rotating from side to side). Heave and sway will be the two controlled by the drive mechanism.

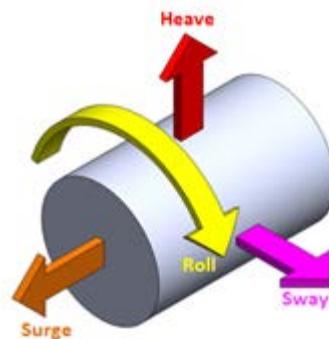

Figure 11: Degrees of Freedom

2.5.1 Servo Motors

A servo motor is an electric motor that has built in control of either speed or position. Constant rotation speed is not a property that is necessary to the project, but position control is. Position control is often achieved by having a potentiometer inside of the motor. A potentiometer is a device that changes its electrical resistance depending on motion. Translation and rotation are the two most often motions used. The limitations of potentiometers are that they limit the motion of the servo motor. This means that when a rotational potentiometer is paired with a motor to create a servo motor, the number of rotations it can achieve are limited. If a large number of rotations are required and optical encoder can be used. An optical encoder registers the position of the motor by counting the number of times a light signal is interrupted. This is often achieved using a spoked wheel that rotated with the motor. Another example of a servo motor is a stepper motor. A stepper motor separates its rotation into steps. A stepper motor with a resolution of 256 would have 256 steps in its rotation. These motors often only rotate 360° -(Sawicz). An example of a potentiometer servo motor is the Hi-Tec HS-7975HB (Figure 12).

It has a full rotation range of 180°, a precision of 0.1°, a maximum torque output of 10 N, and operates in the range of 4.8V to 6V.



Figure 12: Hi-Tec HS-7975HB Servo (RCD)

2.5.2 Linear Actuators

A linear actuator turns energy, in this case electric, into linear motion. The three common types are hydraulic, pneumatic, and mechanical. Both hydraulic and pneumatic actuators work in a very similar way with the only difference being the working fluid. In a hydraulic system, the working fluid is a liquid, often a special kind of hydraulic oil while in a pneumatic system the working fluid is a gas, typically air. The most common design is a cylinder with fluid on both sides. As fluid is pumped into one side, it is forced out of the other. The piston moves in that direction and is used to create useful work. To reverse direction, fluid is pumped into the other side. This requires a pump system to move the fluid and increases complexity. The force output provided by hydraulic and pneumatic actuators is determined by two variables: the pressure provided by the pump and the cross sectional area of the piston. This means that the pump and actuator need to be chosen together to get the correct force output. The benefits of using hydraulic and pneumatic cylinders are their high force output, and the fact that the output is linear. These systems are prone to leakage issues. Air escaping is not a large issue, but leaking hydraulic fluid could be a health risk, and leaked fluid would need to be replaced. The accuracy of these devices is less than optimal because they are controlled by a pump. This is amplified in the pneumatic system because of the fact that gasses are compressible.

A mechanical linear actuator translates rotational motion to linear motion. Two examples are a rack and pinion and a traveling-nut actuator (Figure 13). In the traveling-nut actuator an electric motor turns a screw. There is a nut placed on the screw, and held in such a way that it cannot rotate. When the screw is turned, the nut moves linearly. The maximum force output is determined by the motor and the twist rate of the threads. This system has the capability of being much more precise than the fluid-driven actuators because of the controllability of electric motors.

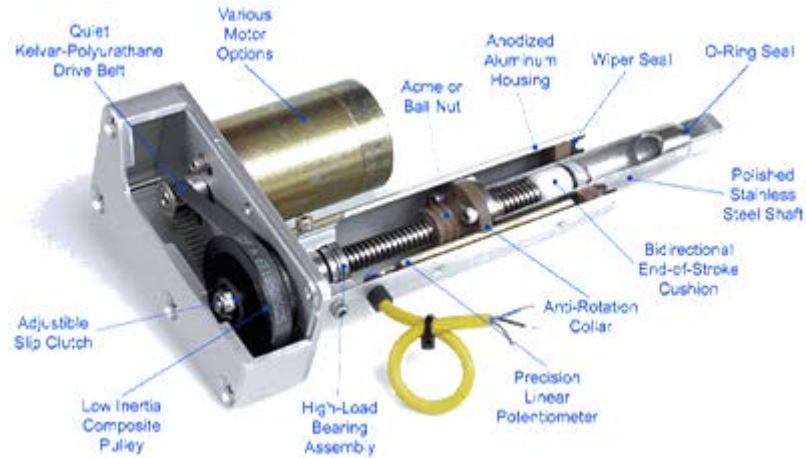

Figure 13: Traveling-nut linear actuator (The Bug)

2.6 Microcontroller

A microcontroller is an essential component of this project. The project needs a device that can read and process signals from both the probe and the user Interface. Then the device is expected to control and output signals to the drive mechanism and user feedback interface. A microcontroller is able to achieve these expectations. A system that uses microcontroller is usually called an embedded system. The microcontroller eliminates the need to use a full computer to achieve some simple purposes. Also, a microcontroller is an ideal specialized tool for controlling the motor as well as other functions. A computer is not specialized to perform such functions, thus a microcontroller has to be used to meet our needs.

A typical microcontroller has the following components: CPU, memory and peripherals. There are two popular architectures for a microcontroller: Von Neumann architecture and Harvard architecture. Both of these architectures have the components mentioned previously. The difference between these two structures is that Harvard architecture has separate memory address spaces for code and data. Von Neumann architecture has single memory address space for code and data. The advantages and disadvantages of the Harvard architecture are that it can save cost and power but at the same time sacrifices easy programmability. Von Neumann architecture has the opposite benefits and drawbacks. The CPU of a microcontroller is used to run basic mathematical, logical and Input/output operation. It will execute program instructions, provide timing, and control operation of memory peripherals. The memory is used to store the information processed in the microcontroller. It stores binary information and is under control of the CPU. There are two kinds of memory, volatile and non-volatile. Volatile memory is code memory, which will be eliminated when the system shuts down. Non-volatile memory is data memory which will be kept in a shutdown. Volatile memory is more important

to this project because the microprocessor will not need to store data when the TEE is not in use. The peripheral is an auxiliary device that gives the host microcontroller other capabilities. There is no limit or strict definition for the “other capabilities”. It provides means of exchanging data with IO devices. Examples of peripherals include all kinds of sensors, graphic cards, cameras, mouse, keyboard, and so on. In this project, the sensors, motors or controllers used are all treated as peripherals to the microprocessor. The microprocessor will process the information among the peripherals at the CPU and store that information in the memory. The CPU, memory and peripheral are connected to each other through data lines, address lines and control lines. Data lines connect the peripherals to the CPU and memory. Control and Address lines connect the memory and the CPU (Texas Instruments).

An example of a microcontroller that could be used in this project is the MSP430F449 Model from Texas Instruments (Figure 14). The MSP430F449 is an ultralow power 16-bit microcontroller that targets low power and portable applications.



Figure 14: TI MSP430F449 Microcontroller (Texas Instruments)

This microcontroller uses a supply voltage of 1.8 to 3.6 VDC. It has 60KB flash memory and 2KB Ram. It has 8 channels of 12 bit analog to digital converter. It has three timers including Timer A, Timer B and watchdog timer. It has 6 Input/output ports for binary data. It has 16 bit data bus and 16 bit address bus. It uses Von Neumann architecture. The CPU of this microcontroller is 16bit RISC. It has 16-bit registers. The wakeup time from low power mode to active mode is less than 6 microseconds. It has two universal serial synchronous/asynchronous communication interface, 48 I/O pins and a liquid crystal driver of up to 160 segments. These are just some key features of the microcontroller. Because of the complexity and large number of features of a micro-controller, more details will not be introduced here. A full description or data sheet of this microcontroller can be found at the Texas Instrument website (Instruments). This microchip will likely satisfy the need of this project because it not only offers enough channels but also have other preferable features such as Von Neumann architecture, 16 bit processor an

low power mode. However, there are thousands of other microcontrollers that could also satisfy the project requirement. A more detailed research into the microcontroller is needed before making any decisions.

Chapter 3: Project Objective

The TEE procedure is a very useful diagnostic tool for doctors around the world. Unfortunately, multiple specialized personnel are required to operate the probe during the procedure. This personnel requirement not only escalates the cost of the procedure considerably, but creates unnecessary inefficiencies as well. Our project intends to alleviate these problems through the development of a modified TEE probe that eliminates the need for additional personnel.

3.1 Problem Statement

The design of the current TEE procedure and probe require at least two highly specialized doctors for the procedure. These doctors consist of an interventional cardiologist and an echocardiologist. The interventional cardiologist typically governs the procedure and often stands near the patient's abdomen in order to do the other tasks associated with the specific procedure. Meanwhile, the echocardiologist stands by the patient's head to operate TEE probe. After the initial insertion of the probe, the interventional cardiologist instructs the echocardiologist how and where the probe must be maneuvered to. The interventional cardiologist will continue to make adjustments to probe position with the aid of the echocardiologist until the probe is removed.

The major problem that arises from TEE procedure is the cost associated with having an echocardiologist in the room for the duration of the operation. By extending the controls of the TEE probe to the interventional cardiologist, the echocardiologist would no longer need to be present to control the TEE probe during procedures. Eliminating the need for 2 specialized doctors to be present for the entirety of the procedure would substantially lower the cost of the TEE procedure. The lower cost allows a broader range of patients to have access to a potentially life-saving procedure. Additionally, the decrease in cost would open the procedure to smaller clinics that previously could not afford to conduct such operations.

In addition to raising the costs of TEE procedures, the echocardiologist also adds complexity in the scheduling of the procedure. The small numbers of specialized echocardiologists and interventional cardiologists have resulted in high demand for the doctors, often filling up their schedules. Since both of

these doctors need to be present for the entire TEE procedure, both must find a convenient time to conduct the operation. This often results in procedures being excessively postponed or delayed.

The efficiency of the TEE procedure also suffers greatly since having extra personnel consumes valuable space in the operation room. Removing unnecessary personnel will help to make the operating room less crowded and increase the efficiency of the procedure. Inefficiencies also arise in the maneuvering of the TEE probe during the procedure. The interventional cardiologist's verbal commands to the echocardiologist for maneuvering the probe could cause confusion and create delays if the commands are not understood. It is often not very easy to see or understand the view the interventional cardiologist is trying to look for.

All of these problems mentioned stem from the use of unnecessary personnel. By eliminating this need, the efficiencies and cost of the procedure will greatly decrease. This will create the opportunity for the procedure to be used more widely and be accessible to a broader range of people.

3.2 Goal Statement

“To research and design a feedback system capable of communicating the forces between the TEE probe and the wall of the gastrointestinal tract.”

Develop a feedback system capable of accurately representing forces between the TEE probe and the walls of the gastrointestinal tract while manipulating the TEE probe. The final product should be able to provide a signal to a user interface and provide the operator with visual or haptic interpretation of the force at the probe/esophagus interface. The prototype should accurately determine the force the TEE applies to the gastrointestinal tract's walls and provide a signal capable of interpretation by a microcontroller. The prototype itself must not harm the walls of a gastrointestinal tract by as scratching, perforating or applying excess force to the surrounding tissue. In order for the TEE probe to be capable of performing its function, the transducer must stay in constant contact with a gastrointestinal wall. Once the prototype is completed it must provide an interpretable signal while maintaining existing TEE probe's current range of motion.

3.3 Design Specifications

Design specifications are a very important tool for creating and evaluating designs. The project will require multiple subsystem designs and thus the design specifications are divided into five categories, including: Entire system, Sensors, Drive Mechanism, Microcontroller, and User Interface. Each category specifies the goal and requirements for each system. Giving the interventional cardiologist control over probe requires the system to have a remote user interface to facilitate probe

movement. A drive system is then needed to actuate the motion in the distal end of the TEE probe. The motions of the TEE transducer in the gastrointestinal tract will generate forces between the probe and the tissue. Force feedback to the doctor then becomes a necessity in order to avoid the application of excessive force, dictating the need for a sensor system. The successful integration of the various systems mentioned will require a microcontroller to coordinate their functions. Based upon this understanding of our project, the following designs specifications were drafted.

3.3.1 Entire System

1. The TEE must be capable of 4 degrees of freedom:
 - a. Heave (up-down)
 - b. Sway (left-right)
 - c. Surge (forward-backward)
 - d. Roll (tilting side to side)
2. Heave and sway must be controlled by the Drive Mechanism
3. The device must have one to one correlation between input and output degrees of freedom
4. The device must continue to comply with FDA regulations
5. The amount of motion at the probe end should be the same as that of the original TEE
6. The number of standard parts should be maximized. The manufacturing materials should be able to be either purchased or made
7. The response time from user input to motion output should be less than 0.1 seconds
8. Minimal maintenance should be needed for at least 5 years
9. The maximum amount of force the TEE exerts will not harm the esophagus

3.3.2 Sensors

1. The esophageal end of the TEE must not be larger than its current size
2. The sensor installed should not interfere with the existing operation of the TEE (ex. Ultrasound)
3. The sensor should measure the force that the TEE applies to the esophageal wall
4. The sensor must provide a signal that can be interpreted or modified to be interpreted by the microcontroller
5. The sensors should provide accurate readings without maintenance for 5 years
6. The precision of the force sensor should be within a tolerance of ± 0.5 N

3.3.3 Drive Mechanism

1. In operation, the drive mechanism cannot restrict the motion of the TEE

2. The drive mechanism should provide at least 9 Nm of output torque
3. The drive mechanism should provide consistent torque output for at least 5 years
4. Must provide enough displacement to create the required range of motion at the distal end
5. The drive mechanism must be able to control the tip of the TEE with a precision of $\pm 1^\circ$
6. Should provide smooth and continuous motion

3.3.4 Microcontroller

1. Must be able to interpret the signals provided by the sensors
2. Must be able to interpret the signals provided by the user interface
3. Must be able to transmit the information interpreted from the sensors and transmit it to the feedback mechanism
4. Must be able to transmit the information interpreted from the user interface and transmit it to the drive mechanism
5. Must have enough pins to connect to all input and output devices

3.3.5 User Interface

1. Design of interface should prevent unwanted motion at the tip of the TEE
2. The user interface should be intuitive
3. Must provide user feedback of the force applied at the distal end of the TEE
4. User interface must be conveniently accessible to the operator
5. The user should be able to operate the distal end of the TEE with a precision of $\pm 1^\circ$

Chapter 4: Preliminary Designs and Zeroth Order Prototyping

This section shows the design process leading up to the selection of a final design. This process was split up into three sections: sensors, drive mechanisms, and user interfaces. Each design specification was considered carefully when determining the merits and potential issues with each design. The weight of each design specification was determined with the aid of the pairwise comparison. This weight was used to make a decision matrix. Each potential design was then input into this decision matrix to help choose the best in each category. The designs were then analyzed for compatibility, and a final decision was made.

4.1 Sensors

4.1.1 Force Sensitive

Using FSRs placed at the tip of the TEE, the sensors can measure the forces that the tip exerts on the esophageal wall. A membrane would have to be placed over each sensor to keep them dry, as well as preventing any contamination of the patient. The biggest advantage this design has is the ability to know exactly where on the tip the force is being applied, and that no matter how it is moved the force will be registered. The disadvantages are that the sensors have to be placed at the tip, which requires a redesign of the probe of the existing device, which requires additional FDA approval. The rubber tip on the TEE is as large in size as it could possibly be in order for it to pass FDA testing, which means that the sensors and the membrane together would have to be the same thickness as the existing rubber coating. Additionally the ultrasound transducer is also located at the tip of the probe (Figure 15). In addition, the sensors must not compromise the current operation of the probe. FSRs are not extremely accurate, and so the maximum force would have to be lowered significantly to accommodate the sensitivity of the sensor. The membrane would also exacerbate the issue as it is another layer of material in between the sensor and the esophageal wall. The problem would happen because the membrane will replace the existing rubber and thus change the current tactile feeling of the probe. This membrane will also likely influence the ultrasound quality as an additional obstacle.



Figure 15: Left, Front, and Right views of Force sensitive resistor initial design

4.1.2 Tension Sensor

This design utilizes a tension sensor in order to determine the forces applied to esophageal tissue. In this design, a tension sensor measures tension in the drive cables of the TEE Transducer. To ensure proper function of this sensor, it should be placed immediately before the protective membrane sealing distal end of the probe (Figure 16). One advantages of using this type of sensor is the accuracy of the measurement that is provided. Another is that the TEE currently uses a slip clutch as a safety mechanism which limits the maximum tension in the wires. This design would be using the tension in the wires which Phillips has determined is a good measure of the force exerted on the esophageal wall. Disadvantages to this design are the requirement of extensive modification to the current device, multiple sensors for the separate wires, and a possible interference with the transducer's functionality. While the amount of modification required is less than that of the FSRs, the transducer membrane would need to be partially removed to expose the wires. The wires may even have to be cut. The section of cable where the sensors are housed would need to be held straight to prevent too much slack developing near the sensors and to prevent them from touching anything nearby which would limit the range of motion. Also, because each wire is only in tension half of the time, how the sensor would operate while not being held taut is uncertain and needs to be tested.

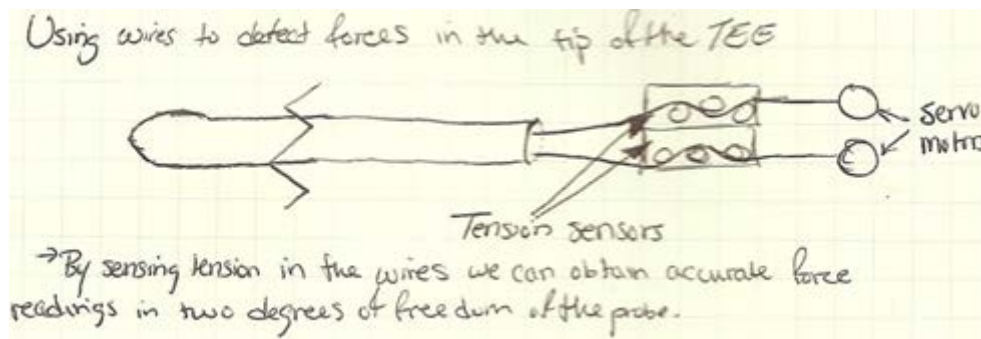

Figure 16: Side view of tension sensor design

4.1.3 Torque Sensor

A torque sensor would measure the torque between the drive mechanism and the knobs on the TEE. This sensor could be attached anywhere inside the drive mechanism. The advantages of this design are that it requires no modification of the existing TEE. The sensor and the drive mechanism can be developed together, and only two sensors would be required. Minimal modification to the TEE transducer's distal end is desirable since this portion of the device resides in the gastrointestinal tract during operation. Additionally, minimal modification to the distal end allows for the device to pass FDA regulations easier and reduces possibility of interference with operation of the TEE transducer's functions. Torque sensors on the market are very expensive and are intended for a wide variety of applications, therefore suggesting the design and manufacture of a torque sensor specifically for this application will be necessary. The design of a torque sensor will require the need for wires and sensors which may entangle during the operation of the TEE transducer, and therefore limit possible designs. The project groups torque sensor should be designed to rotate minimally in order to decrease the possibility of entanglement. This makes the shaft connecting the current TEE controls (Figure 14) to the rack and pinion a perfect place because it does not rotate more than 180° and the maximum torque at this location can be measured more easily than other locations.

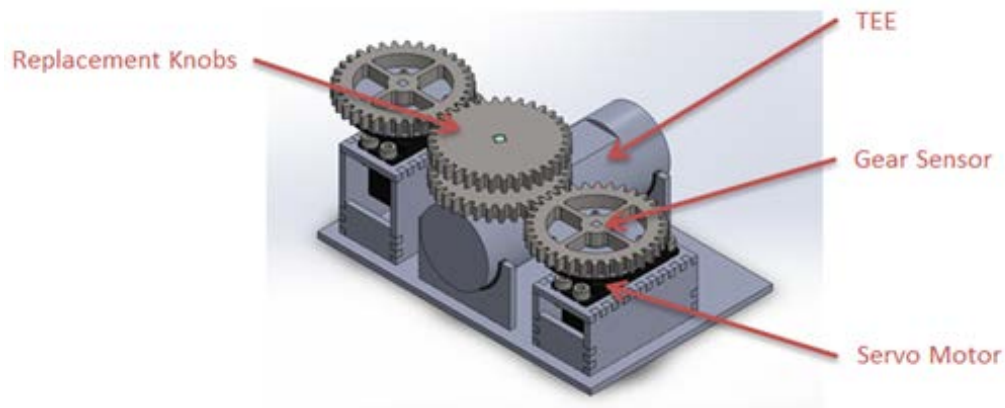

Figure 17: Design of torque sensor system

An example of a torque sensor design is the gear sensor. The knobs on the TEE are replaced with gears which will each mesh with a gear sensor (Figure 18). This gear sensor will measure the torque required to turn the knob by measuring the strain in the spokes with strain gauges. Important design considerations are the size of the gear and the dimensions of the spokes. A zeroth order prototype will need to be developed to verify if this concept works.

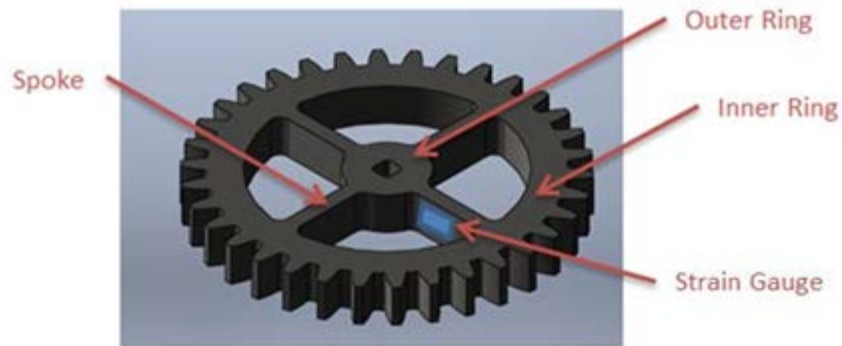

Figure 18: Torque sensor example

4.2 Drive Systems

This section describes and details the feasibility of different drive systems to be used in the final prototype. The drive system is responsible for the movement of the probe tip. Currently, the system is driven using manual hand controls located on the proximal end of the TEE probe. The intent of this section is to develop designs capable of replicating this control efficiently.

4.2.1 Existing Rack and Pinion

This design uses the existing rack and pinion of the TEE probe, but replaces the current hand knobs with gears. A servomotor would then be used to drive the gears, which had been substituted for the previous hand knobs. This potential drive system design can be seen in Figure 19.

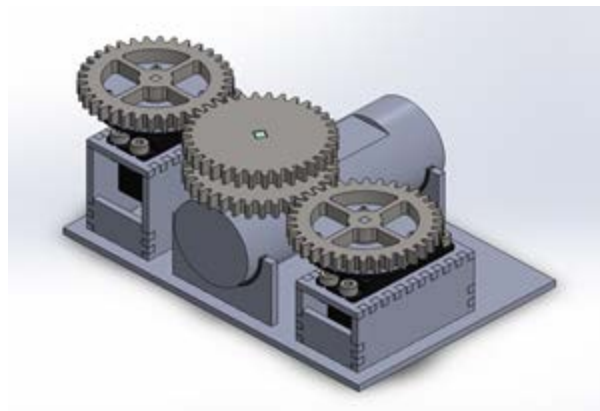

Figure 19: Illustrates a design using the existing TEE probe's rack and pinion. Gears are mounted where previous hand controls once existed and are driven by servomotors.

Using the existing rack and pinion would be the easiest to implement since only minor modifications would need to be made to the existing device. The simplicity of the design increases reliability, as there is less opportunity for part failures and system glitches. An important consideration with this design is the gear ratio between the motor and the shaft. A lower gear ratio is preferable due

to the increase in precision while being less likely to be back-driven. Back-drive occurs when the external forces acting on the TEE probe overcomes the motor. This results in the unwanted motion of device and could prevent the TEE probe from applying an intended force or remaining in a crucial position. A higher gear ratio would be disadvantageous, requiring more powerful motors while delivering less accuracy.

The incorporation of a worm gear, like the one seen in Figure 20, could be beneficial to the system. This helps prevent the motor from being back-driven when force is applied to the tip of the TEE. Worm gears also provide a high mechanical advantage, increasing the torque or a motor output substantially. The use of a worm gear could be the difference between a more powerful but costlier motor and a cheaper, yet less powerful motor.

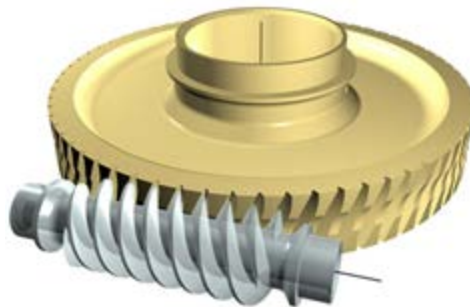

Figure 20: Shows an example of a worm gear configuration. Worm gears provide maximum torque and precision, all while nearly eliminating the concerns of back-drive.

4.2.2 Linear Actuator

The use of a linear actuator as a drive system for the probe tip would require extensive modification to the existing TEE device. This would require dismantling the TEE probe to separate the main control housing from the tubular end to expose the wires controlling tip movement. An actuator would then be attached to each of the 4 exposed cables to control the tip motion, or two actuators for each degree of freedom [Figure 22]. The two actuators controlling a degree of freedom would then operate in conjunction, moving equally and opposite to maneuver the tip in the respective degree of freedom. Figure 21 shows the overall design idea while Figure 22 shows highlights the degrees of freedom the actuators would control.

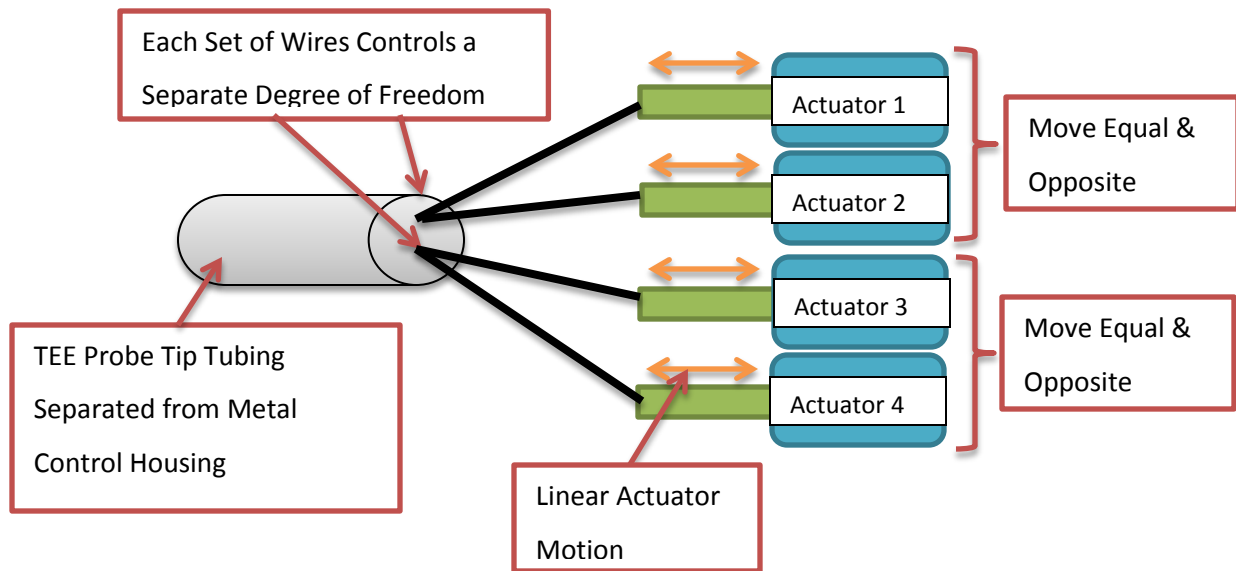

Figure 21: This image displays the design concept for using linear actuators. 4 Linear actuators attached to each of the tip control wire move equally and oppositely in a pair to operate the heave and sway degrees of freedom.

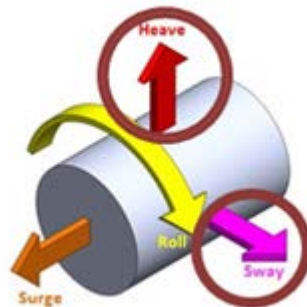

Figure 22: This image designates the degrees of freedom, which would be controlled by actuators.

The linear actuator drive system requires major modification to the existing TEE, which in turn decreases reliability. A pneumatic actuator has two major issues. The first is that air is extremely compressible and would cause problems with accuracy. The second is that combining them with electronic circuits to use feedback loops would not produce smooth and gentle movements. These are both safety concerns. Additionally, the end package for a system using pneumatic actuators would be unnecessarily large. Electric linear actuators abate these safety concerns, but still require major modification. This design also eliminates the many potential possibilities to use a torque sensor.

4.2.3 Motor with Spool Attachment

The spool design replaces the rack and pinion system currently found in the TEE with a spool of wire. This spool is connected to gears and a servomotor. Two spools would be attached to each motor. By alternating which direction it a spool is wrapped, symmetric motion can be achieved (one spool wraps while the other unwraps [Figure 23]). This design concept is illustrated in Figure 24. Because of the variable diameters the spooling would produce, the motion would not be perfectly symmetrical. This is caused by change in the pool radius as wire is wrapped and unwrapped. This system could cause several problems. The first is the bending and possibly breaking of the wire due to fatigue as it is constantly wrapped and unwrapped. Another potential issue is that the wires could slip off the spool or become tangled.

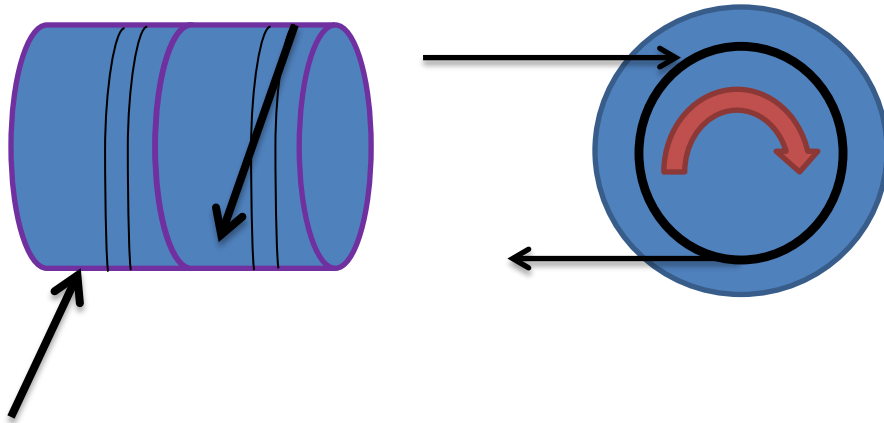

Figure 23: Illustrates how wrapping connected spools in alternating directions would allow one wire to be pulled in while letting another out.

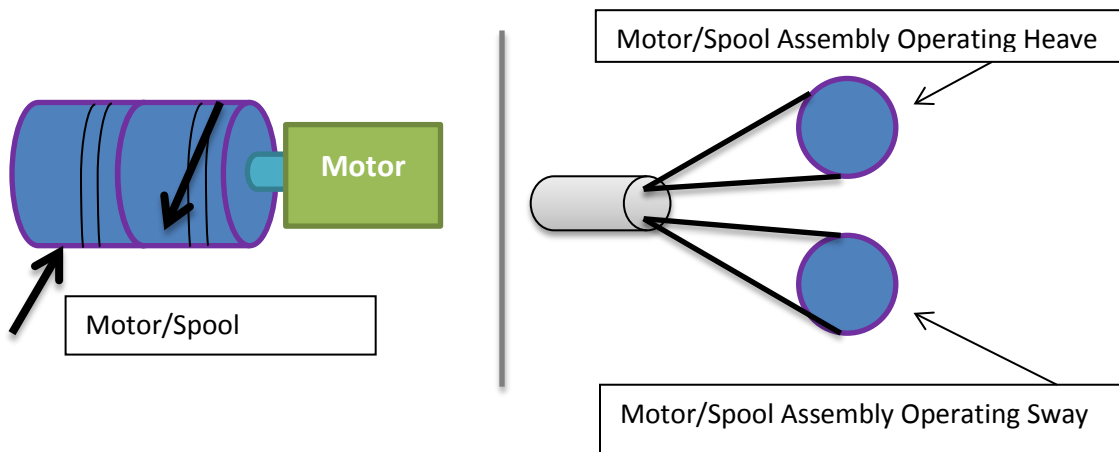

Figure 24: Image on the left shows the motor and spool assembly. Image on the right shows the overall design concept.

4.3 User Interface

4.3.1 Force Feedback Steering Wheel

The advantages of a steering force feedback wheel is that it will act like the current knob control mechanism and force feedback is relatively easy to accomplish as many steering wheels come with a force feedback mechanism built in. For example, Logitech produces a series of force feedback wheels including Drive Force GT, G27 Racing Wheel (Figure 25). Another advantage is that the team will be able to use the wheel without the need to know details about designing force feedback devices. The built-in programs for existing steering wheels will make it an easy and better way to achieve the team goal. The disadvantages are that the available products have only has one degree of freedom and are large. The DOF issue can be mitigated by having a switch (like the shifter on the right of Figure 17) to change which degree of freedom on the TEE is being controlled, or to have multiple wheels. The size problem can be solved by replacing the wheel with a knob, whose size will be determined based upon whether it can provide a sensitive tactile feedback.

The feedback system is ideal for the TEE. As the force at the distal end of the TEE increases, the wheel becomes harder and harder to turn. When the limit is reached, the wheel could not be moved in that direction any more. This allows the surgeon to see how far the tip of the TEE was moved before the force limit was reached, much like the current design.

To lock, a button would be pressed on the steering wheel. The wheel would then use its built-in force feedback system to prevent all motions of the wheel until the lock was turned off. Such function of the steering wheel will enable the controller to mimic the existing knob.



Figure 25: Force feedback steering wheel

4.3.2 Joystick

A joystick system (Figure 26) can have between 2 and 3 DOF. The advantages are that it has a large number of degrees of freedom and has built in force feedback. This design has a 3 DOF joystick and a 1 DOF lever. The joystick could control heave sway and roll, while the lever could control surge.

The X and Y axes on the joystick have force feedback similar to that of the wheel. The lock would work in a similar way to the steering wheels. The force feedback mechanism would prevent movement in the X and Y directions, but a software disconnect would need to be used to prevent movement in the remaining 2 degrees of freedom for this specific product. There exist other joysticks that do not have the additional degree of freedoms. Those joysticks could be a better option for this application.



Figure 26: Joystick system

4.3.3 Conventional Game Controller

An Xbox Controller (Figure 27) is another practical solution for controlling 2 degrees of freedom. The advantages are the ease of communicating with the controller, the large number of buttons, built in wireless, and feedback. The disadvantages are that the only real feedback it can provide is vibration, that it requires 2 hands to operate, and that it is not very intuitive.

There are a large number of options when deciding what on the controller controls each degree of freedom on the TEE. There are the X, Y, A, and B buttons, the left and right sticks, and the D-pad. The buttons could provide 2 degrees of freedom control. The D-pad can provide an extra 2 degrees of freedom control. The only lock that could be used would be a software disconnect. This prevents unwanted motion at the tip of the TEE, but the controls would still move. This design is the simplest way to control 4 degrees of freedom if necessary. However, given that the focus of this project is on 2 degrees of freedom, the extra buttons could be a waste, which is a disadvantage of using Xbox controller.



Figure 27: Xbox Controller

4.3.4 Keypad

This design uses the arrow keys on a computer for control, and equalizer-like LEDs for feedback (Figure 28). An additional keypad could be used to control two additional degrees of freedom. The advantages of this are that it is extremely easy to implement, and the feedback is very precise. Because existing keypads normally do not provide force feedback, visual feedback will be used to show the force received at the probe end.

There would be an LED strip for each degree of freedom. The LEDs would fade from one color to another (ex. green to yellow to red). As the force approached the limit, more LEDs would light up. When the last LED was lit, it would indicate that the force at the tip has exceeded the maximum safety force. If more degrees of freedom were needed, more keys could be used. This would also use a software disconnect as a lock.



Figure 28: Keyboard with LEDs

4.4 Zeroth Order Prototype

A zeroth order prototype is an early prototype used to test simple concepts. Only one zeroth order prototype was manufactured for this project although multiple are typically used. This prototype (Figure 29) was used to test the initial gear sensor design and verify that it was possible to construct an adequate torque sensor. The Objet rapid prototyping machine was used for ease of manufacture. This allowed a quick turnaround from design to finished part and also served to determine if the rapid prototyping machine would be appropriate for manufacturing the final product.



Figure 29: Zeroth order prototype gear sensor

4.4.1 Gear Sensor Design

Finite element analysis [FEA] was used to determine the correct dimensions for the zeroth order gear sensor. A model was created in SolidWorks with the appropriate dimensions to accommodate the size of the strain gauges available (Figure). The strain gauges are 0.125" wide and 0.25" long. The spokes were made 0.325" long to accommodate the wires attached to the strain gauge. The thickness of the spokes, outer, and inner rings were determined with FEA so that the material would not break under maximum load. A safety factor of 5 was used on the outer and inner rings to prevent excessive deformation, while a safety factor of 2 was used on the spokes because deformation is necessary for the sensor to operate. A square hole in the center was used to allow for torque to be applied to the center. The size was determined using the dimensions of the standard VEX axels because of their availability and the ease of construction of a simple VEX apparatus.

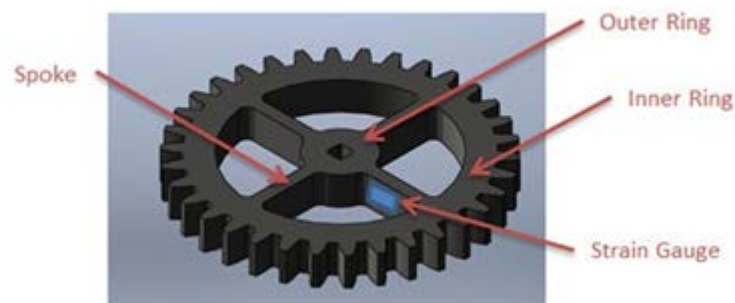

Figure 18 Repeated: SolidWorks model of the zeroth order gear sensor

4.4.2 Finite Element Analysis

A second set of FEA models were developed after the sensor was designed (Figure 30). These tests determined the strain present in the spokes. This is important because the strain in the spokes is what will be measured by the strain gauges placed on them and the specifications for the strain gauges needed to be determined. The rapid prototyping machine does not print solid parts, it instead prints them with a honeycomb like internal structure which causes the material properties to not be exact. While the lowest material strength could be used to determine the size of the part, the strain had to be tested at both extremes to verify that it would be at least 100 micro strain on the spokes. This yielded a range of strains that would be present in the spokes. A strain gauge was purchased that could measure this strain.

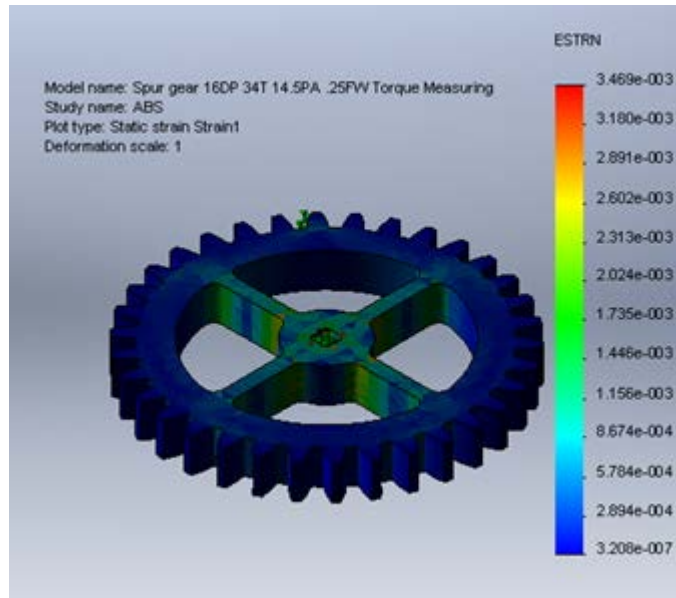

Figure 30: Finite element analysis of gear sensor to determine strain

4.4.3 Construction, Testing, and Results

The strain gauge was glued to the spoke of the gear sensor (Figure 31), and then it was wrapped in tape to protect it. A stress relieving loop was added to protect the solder joints. A VEX axel was fixed in a clamp, and the gear was placed on it. A multimeter was attached to the wires and the change in resistance was measured when torque was applied to the gear. A change of $\pm 1 \Omega$ was measured. This would result in a change of approximately $\pm 4 \text{ mV}$ in a 5V Wheatstone Bridge. This is large enough that it is distinguishable from noise when amplified for measurement. The zeroth order prototype design worked well enough to warrant further development.

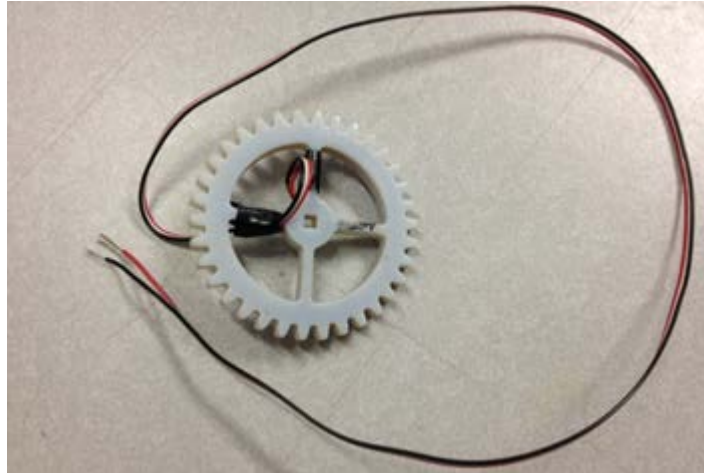

Figure 31: Completed torque sensor

Chapter 5: Selection of Final Design

Two different kinds of charts were used to aid in the selection of the final design. These two chart types are pair-wise charts and decision matrices. A pairwise chart determines the order of importance of the design specifications. This order helps determine a weight associated with each design specification. A decision matrix takes each preliminary design and rates it with respect to the design specifications. This rating is multiplied by the weight determined using the aid of the pairwise chart and then summed which results in a final score for the design. The results from the tables are then evaluated an aid in the final decision. It is important to note that while the charts are numerical they are not precise. The numbers generated aid in the design selection but do not dictate it.

5.1 Pairwise Charts

A pair-wise chart is used to help determine the weights used in a decision matrix. Each design specification is placed once in each column, and once in each row. The specification in each column is compared to each other specification. If the column is more important than the row, a score of 1 is given. If they are equally important, a ½ is given, and a 0 is given if it is less important. This is done for every specification, and then the scores in each column are added together to determine the order of importance. This order is used indirectly to determine the weighting for the decision matrices.

	4DOF	Controlled DOF	One to one IO	FDA	Range of Motion	Standard Parts	IO Time	Maintenance	Max Force
4DOF	X	0.5	1	0	0	0.5	0	0	0
Controlled DOF	0.5	X	0	0	0	0.5	0	0	0
All O controlled by I	0	1	X	0	0	0.5	0	0	0
FDA	1	1	1	X	1	1	1	1	1
Range of Motion	1	1	1	0	X	1	0	0	0.5
Standard Parts	0.5	0.5	0.5	0	0	X	0	0	0
IO Time	1	1	1	0	1	1	X	0.5	1
Maintenance	1	1	1	0	1	1	0.5	X	1
Max Force	1	1	1	0	0.5	1	0	0	X
Sum	6	7	6.5	0	3.5	6.5	1.5	1.5	3.5

Table 1: Entire System Pairwise Chart

	Size	Interference	Force Measurement	Signal	Maintenance	Tolerance
Size	X	0.5	1	1	0	0
Interference	0.5	X	0.5	0.5	0	0
Force Measurement	0	0.5	X	0.5	0	0
Signal	0	0.5	0.5	X	0	0
Maintenance	1	1	1	1	X	1
Tolerance	1	1	1	1	0	X
Sum	2.5	3.5	4	4	0	1

Table 2: Sensors Pairwise Chart

	Interference	Torque	Maintenance	Range of Motion	Precision	Smooth	Lock
Interference	X	0	0	0.5	0	0	0
Torque	1	X	0	1	1	0.5	0
Maintenance	1	1	X	1	1	1	1
Range of Motion	0.5	0	0	X	0	0	0
Precision	1	0	0	1	X	0.5	0.5
Smooth	1	0.5	0	1	0.5	X	0.5
Lock	1	1	0	1	0.5	0.5	X
Sum	5.5	2.5	0	5.5	3	2.5	2

Table 3: Drive Mechanism Pairwise Chart

	Controlled by Surgeon	Lock	Intuitive	Feedback	Accessible	Precision
Controlled by Surgeon	X	0	0	0	0	0
Lock	1	X	0	1	0	0.5
Intuitive	1	1	X	1	0.5	1
Feedback	1	0	0	X	0	0.5
Accessible	1	1	0.5	1	X	1
Precision	1	0.5	0	0.5	0	X
Sum	5	2.5	0.5	3.5	0.5	3

Table 4: User Interface Pairwise Chart

5.2 Decision Matrices

The decision matrix is not the method with which the best design is chosen. It is instead used to eliminate the worst designs to aid in the final design choice. A score of 1-5 is given to each design depending on how well it meets the design specifications where a 1 means it does not meet the specification and a 5 means it meets the specification. These scores are then multiplied by the weights assigned to each specification. The order determined by the pair wise charts decided the order of the weights in the decision matrices. For example, the sensor pairwise chart (Table 2) resulted in the order Force measurement, Signal, Interference, Size, Tolerance, and Maintenance. With the order determined, the weights were established by evaluating the importance of the design specification. It is important to note that all of the weights are a percentage and must sum to 1. A higher score is better.

Name	Weight	FSR	Tension	Torque
Force measurement	0.22	3	4	5
Signal	0.22	5	5	5
Interference	0.18	5	4	5
Size	0.15	2	4	5
Tolerance	0.13	5	4	4
Maintenance	0.1	5	3	5
Sum	1	4.11	4.12	4.87

Table 5: Sensors Decision Matrix

Name	Weight	Rack	Rack+Worm	Spool	Linear
Interference	0.23	5	5	3	5
Range of Motion	0.23	5	5	5	5
Precision	0.15	5	5	3	3
Smooth	0.12	5	5	3	2
Torque	0.12	5	5	3	2
Lock	0.1	2	5	2	2
Maintenance	0.05	5	5	4	3
Sum	1	4.7	5	3.41	3.58

Table 6: Drive Mechanism Decision Matrix

Name	Weight	Wheel	Wheel+Knob	Joystick	Xbox	Keys+LED
Controlled by Surgeon	0.3	3	5	5	2	5
Feedback	0.2	5	5	3	2	3
Precision	0.16	5	4	3	2	3
Lock	0.14	5	5	4	2	3
Intuitive	0.1	5	5	3	2	5
Accessible	0.1	3	5	4	3	5
Sum	1	4.2	4.84	3.84	2.1	4

Table 7: User Interface Decision Matrix

5.3 Selection of Final Design

The Pair-wise charts and the Decision matrices were used as an important reference to make the final design decision. The first part of making the decision involves ruling out non-desirable designs which generally have lower scores in the Decision matrices. In the sensor section, FSR was ruled out mainly because of its size issue, which could affect the ultrasound performance. The tension sensor was given up because of its unpredictable and heavy maintenance issue and unstable nature. Adding a tension sensor to the existing cable system will likely cause the current system to be malfunctioned by affecting the motion of the wires. On making decisions about the Drive System, the spool design and the linear actuator design were quickly ruled out because of their potential inaccuracies and interference with the probe motion. As far as the user interface, Joystick and Xbox controller designs were discarded since they cannot provide precise feedback are less intuitive to use, and add unnecessary complexity to the project.

The second part of making the decision was less dependent on the decision matrices. The decision was made with the idea of proving the concept of the overall design within the timeframe of half a year. With this idea in mind, the Torque sensor was decided without competition from other designs. As far as the driving mechanism, Rack and Worm gear design was ruled out because the torque sensor was designed in a way that does not need extra worm gears. The existing rack and pinion system will be enough for the torque sensor to function. For the user interface decision, the entire wheel design was ruled out because it does not help prove the concept of the overall design any better than a keypad and LEDs, which can be even more intuitive. Visual feedback could a more precise way for the doctor to determine whether the probe reached a certain force. Tactile feedback feature of the wheel design would have added some unnecessary complexities but does not help deliver a better product. In the end, the designs chosen were torque sensor, existing rack and pinion drive mechanism with additional motor control, and Keys + LEDs user interface. The final design decisions then started to guide the project team to make detailed designs of prototype.

Chapter 6: Prototype Design and Manufacturing

A final prototype was designed and manufactured to demonstrate the concept of the design (Figure 32). There are five major components of the prototype design, including circuit design, programming, gear sensor design, housing design, and adapter design. There are four major components of prototype manufacturing, including gear sensor manufacturing, adapter manufacturing, housing construction and circuit construction. The prototype is intended to be a device which is able to meet the project specifications.

There are two major components which contain or use other peripheral devices: the TEE and the Electronics Box. Red lines are used to demonstrate a mechanical relationship between one of the two major components and other devices. Blue lines are used to show an electrical relationship between one of the two major components and other devices. In this design, the TEE will have all the shown mechanical devices installed on it, such as gears and housing. All the electronic components will be held in an electronic box. The TEE and the Electronics Box are connected by cables between motors & sensors and the electronic box components.

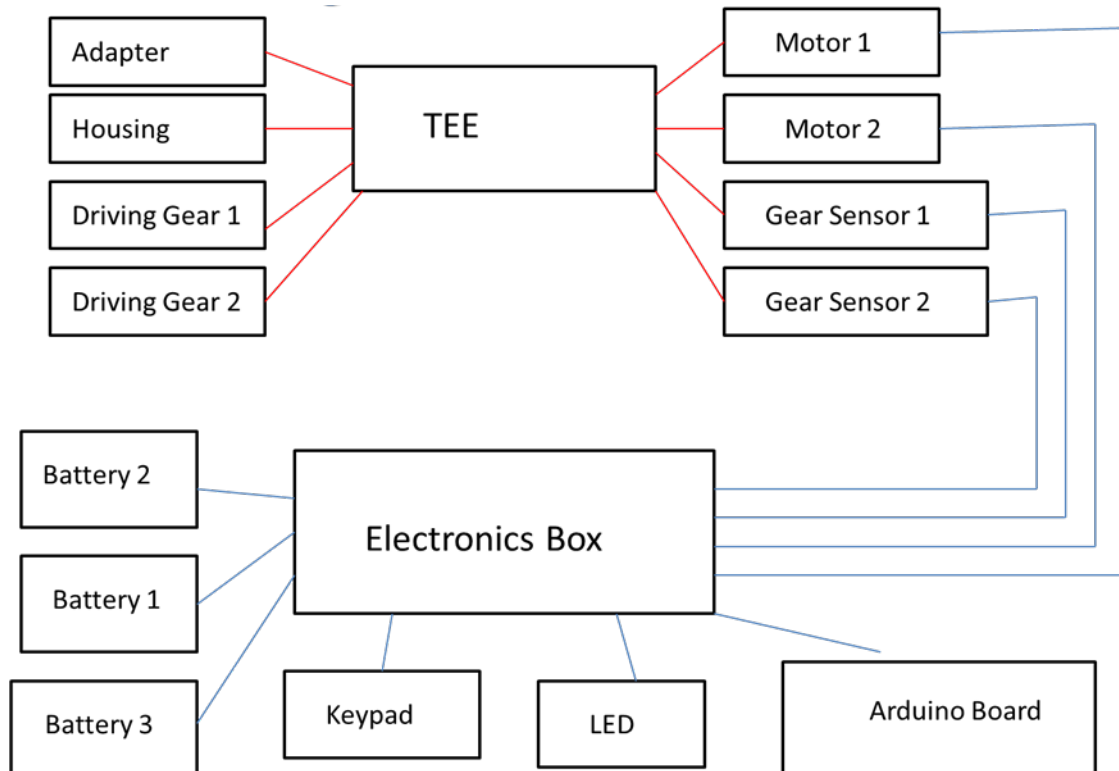

Figure 32: Block diagram of final prototype design

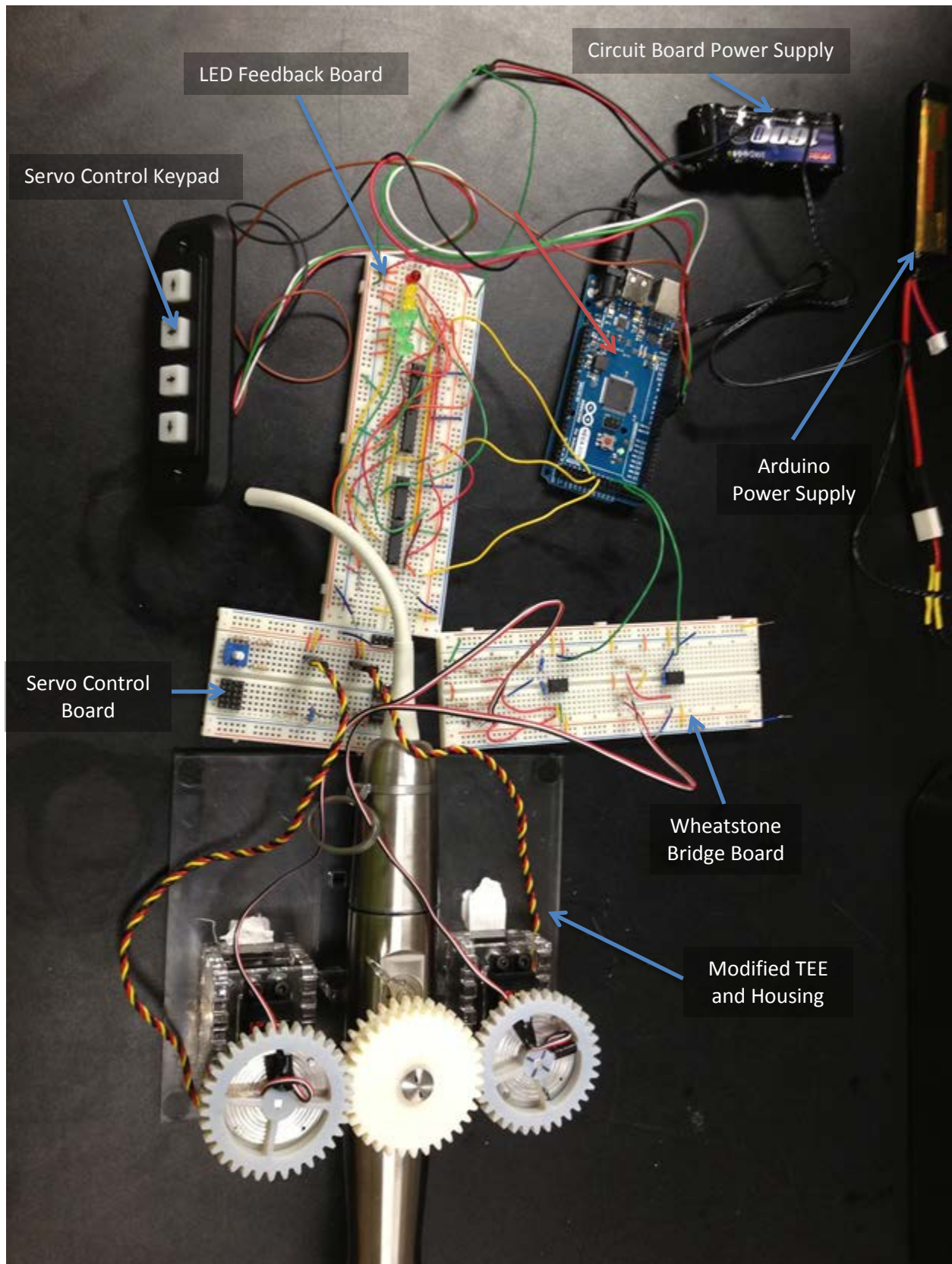

Figure 33: Photo of final prototype with all parts labeled

6.1 Circuit Design

From the successful results of the zeroth prototype testing and final design decisions, a complete circuit was designed to implement desired functions (Figure 34). Those functions include integrating the sensor with the Arduino board, integrating the motor with the Arduino board, integrating the LED with the Arduino board, integrating the Keypad with the Arduino board and powering all the components.

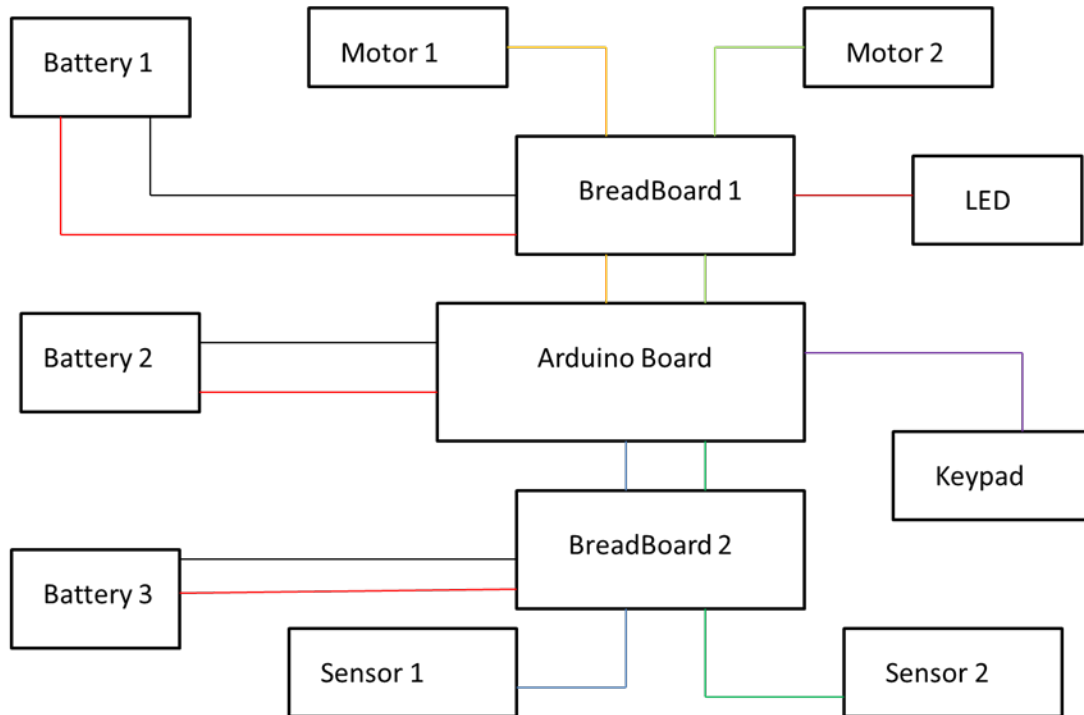

Figure 34: Block diagram final circuit design

The first bread board (Figure 35) manages the connection between the Arduino board and the motors and LEDs. The two motors are powered by one 6 V battery pack. The LED will also use this breadboard for connection purposes. However, the main circuit of the LED will not be on this board. The middle wire of both motors is the signal wire. The motor be controlled by the Arduino Board through this wire.

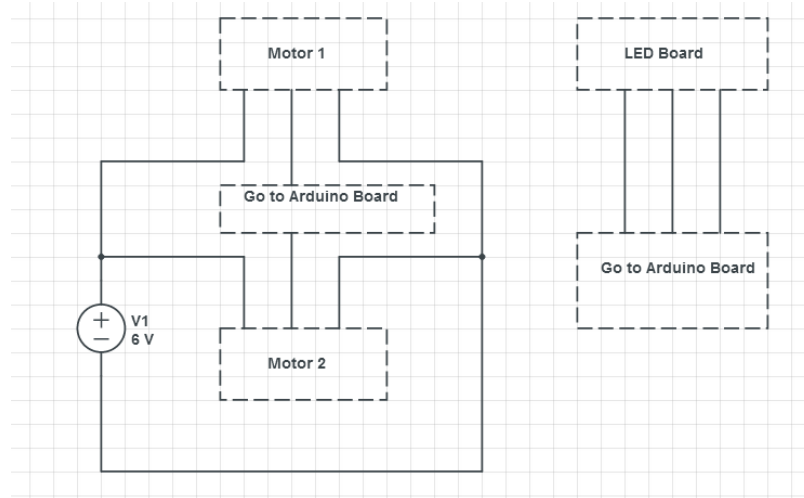

Figure 35: Bread board 1 circuit design

The LED circuit (Figure 36) was designed to be able to control 7 LEDs with three inputs, which are three digital outputs. In this way, there is less space constraint but more easiness to implement the LEDs. The LEDs are controlled through a digital circuit.

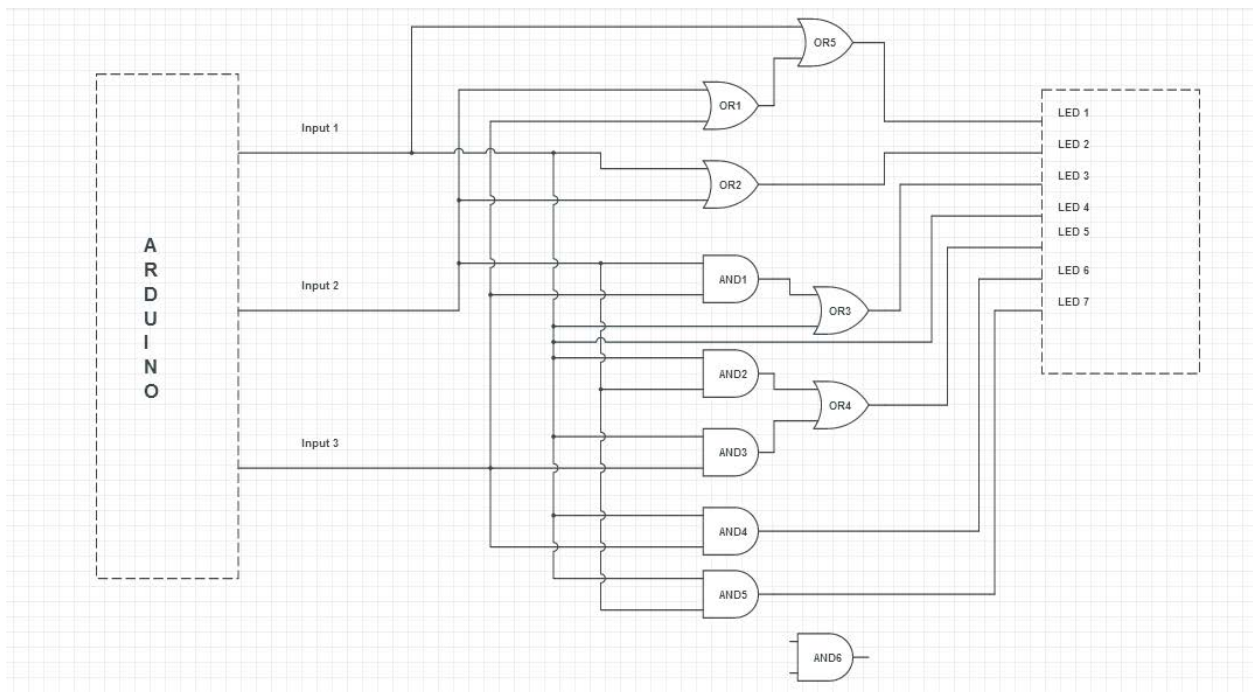

Figure 36: LED Feedback System Circuit Design

The second bread board (Figure 37) is used to read from the two gear torque sensors and provide the AD620 instrumentation amplifier +6V and -6V. Two Wheatstone bridges with two AD620s

are used here. Notice that the AD620 are given a gain of 400 in the circuit but the gain resistors are not drawn.

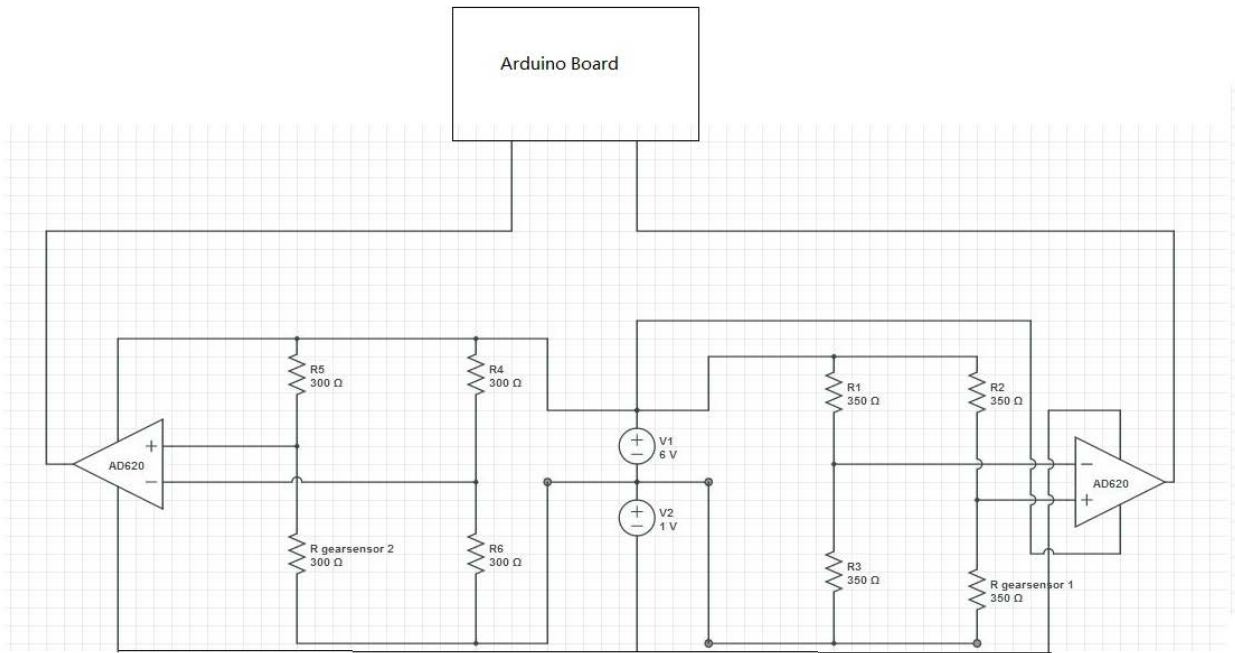

Figure 37: Bread board 2 circuit design

The Arduino board (Figure 38) was used to coordinate all the components. Figure 34 is a detailed diagram of where the components are connected and how the board is used.

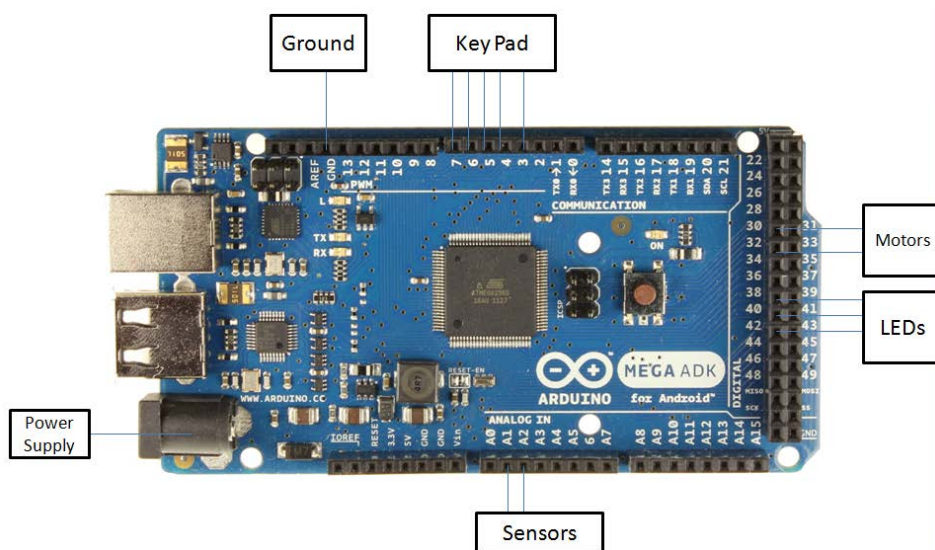

Figure 38: Arduino pin usage diagram

6.2 Program Design

The program for the device is written in C++ with the Arduino programmer. A direct and simple approach is taken toward writing the programs. Two libraries from the Arduino community are used. The first one is the servo.h library. This library provides a way to control the servo motor from 0 to 180 degrees. The second one is the Keypad.h library. This library enables the user to give each key on the keypad a function and allows the user to read the key values. With tools from libraries, individual C++ functions were written for motors, sensors, and LEDs. These functions were then called in the loop function or main function. In the setup function and declaration functions, different Arduino pins were assigned to different electric components. In the main function, a function to get key pad values was used first to keep getting commands from the key pad. Then, an “if” statement was used to check the key pad values and give motor different commands based on the key pad value. At the same time, two sensor functions were used to monitor the sensor value changes. Then, at the same time, the sensor values were converted and reflected in the LED function based on their values. At the beginning of the program, the user needs to wait 5 seconds for the program to set the origin value for the sensors. The reason behind this is that the sensor values vary considerably every time one tests this device. However, the sensor value range is not very different. As a result, the program focuses on the difference in sensor value change instead of its absolute value. The complete code for this project can be found in Appendix B.

The other programming practice used is to program the motors through the motor programmer. Initially the servo was only capable of moving for a range of 120 degrees. This problem was solved through using the Hi-Tec motor programmer. By lowering the motor resolution the motor range can be increased to its full 180 degrees. The lowered resolution is still less than the 1 degree required by the design specifications.

6.3 Housing Design

The housing holds the TEE and all of the other components in place (Figure 39). There are several important factors that need to be addressed in the design of the housing. The first is the rigidity of the system. The gear sensor is measuring extremely small changes in torque. Any movement in the housing could compromise the accuracy of the measurement. Movement could also impact the meshing of the gears. If the gears do not mesh well extra torque could be added to the system, or the gears could skip. The second is manufacturability. The prototype needs to move from design to manufacturing in a relatively short amount of time. It also must be able to be precisely manufactured

for the same reasons that rigidity is important. Fixturing is another consideration. The material choice is important for all of these considerations.

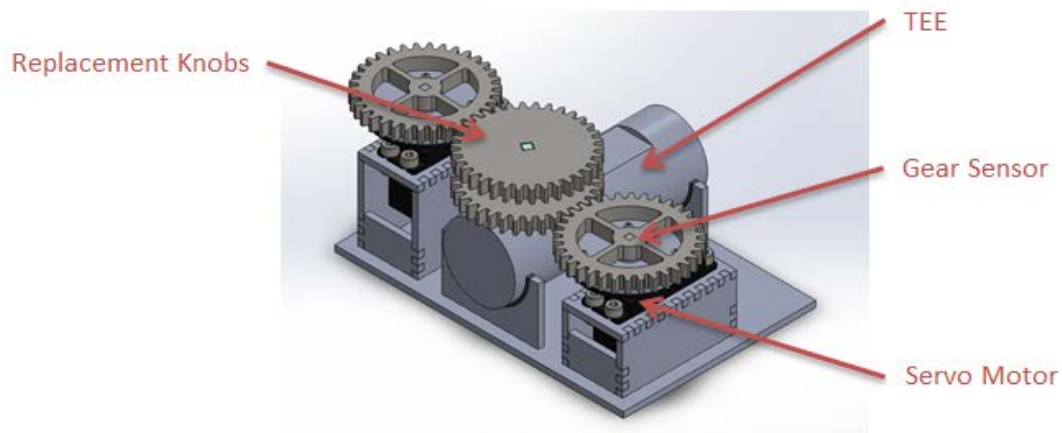

Figure 39: Final housing design

Initial brainstorming yielded four materials suitable for the housing: Wood, aluminum, acrylic, and 3D printed material. Wood parts are very easy to manufacture, but suffer from stiffness issues. Wood is also the weakest of the materials which leads to more rigidity issues. It is also prone to changes in size which would affect the precision possible. It was determined that wood would not be a suitable material to build any parts of the housing out of because it cannot hold the tolerances necessary for the design. Aluminum can be machined using the Computer Aided Manufacturing [CAM] tools available on campus in Washburn Laboratories. Using aluminum yields the highest precision and strength. It also adds ability to use complex geometries. The CAM tools are the hardest to use for the manufacturing of parts. Fixturing is a concern and must be taken into consideration when the parts are being designed. A significant amount of time must also go into preparing a 3D model for production on a CAM machine. Aluminum would then only be a good choice if the precision and strength were necessary. Acrylic is a common choice for a construction material. A laser cutter is available on campus and can be used to produce acrylic parts. The advantage of using the laser cutter is the ease of manufacture. CAD models can be imported directly into the machine and cut in a matter of minutes. Acrylic is also quite rigid and robust. Material printed with the rapid prototyping machine has already been used in the design. The material is weaker than acrylic and aluminum but requires very little work to manufacture. The parts are less precise than laser cut or machined materials, but it is easy to manufacture complex geometries. Other disadvantages are that it is expensive and takes longer than any other manufacturing method because there is a week-long queue to use the machine. The rapid prototyping machine should only be used if necessary.

The motor cradle holds the servo motor in place (Figure 40). Acrylic was chosen as the material because there are no complex geometries necessary. The shorter cradle was designed first as it would determine the minimum height of the housing. The servo has 4 holes for screws which are used to fix it in place. A gap was left on both the front and back of the cradle to allow a space for the wires to exit through and access to the nuts for the screws.

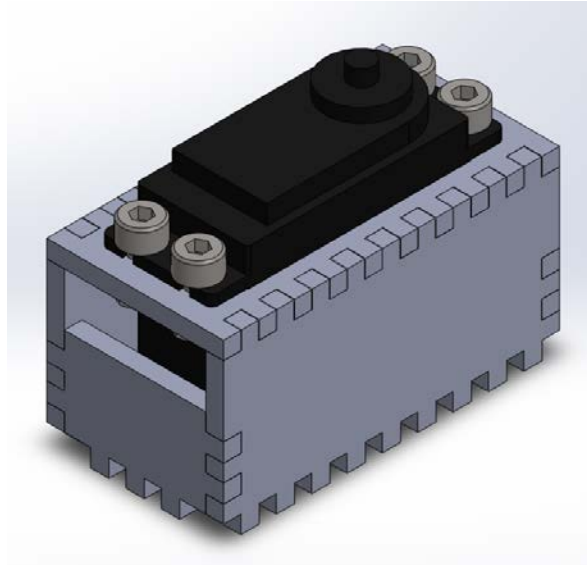

Figure 40: Motor cradle

The TEE Cradle (Figure 41) holds the TEE in place. The cradle consists of 3 plates contoured to the TEE that it rests on. The TEE is fastened to the base plate with two screws. Two holes are drilled into the underside of the TEE and two nuts are placed inside. The screws are tightened to these nuts and hold the TEE tightly to the 3 plates.

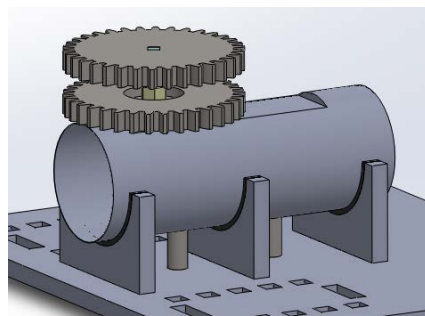

Figure 41: TEE Cradle

6.4 Adapter

The gear design in its current form is unable to attach directly to the servo. The servo uses a very specific attachment mechanism which would be very difficult to replicate as it is made up of many small teeth. The servo does come with several different attachments called horns. The round horn is

the most appropriate for use in the design because it is the largest and the only symmetrical horn included (Figure 42). Aluminum is the appropriate material from which to manufacture the adapter (Figure 43) because the square shaft required is very small, and FEM determined that the rapid prototyping material was too weak to use. There are also four holes that are required to attach the horn to the adapter that are 0.0635" in diameter which is outside of the precision of the rapid prototyping machine. The adapter has a small step in the center. This serves to reduce the friction in-between the gear sensor and the adapter. The outer diameter of the step is smaller than the outer diameter of the inner ring of the gear sensor so that it does not interfere with the spokes. The overall outer diameter of the adapter is the same as the outer diameter of the horn. The holes are placed in such a way that when assembled (Figure 44) the screws are accessible.

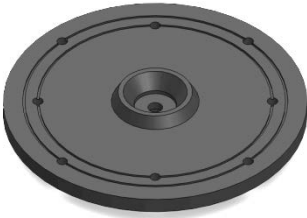

Figure 42: Round horn included with servo

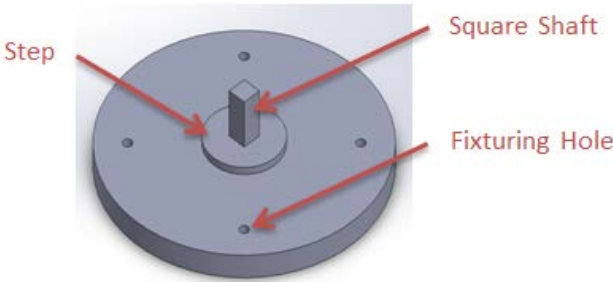

Figure 43: Gear sensor to servo horn adapter

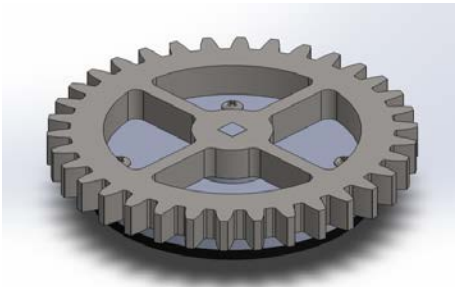

Figure 44: Gear sensor to servo horn adapter assembly

6.2 Prototype Manufacturing

The prototype is the major deliverable for the project. The manufacture of the prototype requires the use of a lathe, mill, laser cutter and 3D printer. Electronics also need to be assembled to read the sensor, read input, and provide output. The Arduino has to be programmed to interface with the rest of the electronics and control the motors.

6.2.1 Gear Sensor

One of the gear sensors used in the final prototype was the same sensor that was used for the zeroth order prototype (Figure 45). A second sensor identical to the first was manufactured using the same process. Wires are soldered to a strain gauge. The soldered strain gauge is then affixed to a piece of clear tape. Super glue is applied to the underside of the strain gauge which is then placed on the spoke of the gear. It is then wrapped in more tape to prevent damage to the sensor. A stress relieving loop is added to prevent damage to the solder joint.

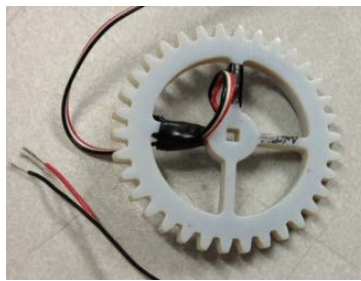

Figure 45: Gear sensor used in the final prototype

6.2.2 Housing

The base of the housing is manufactured from 0.25" acrylic. The acrylic is cut on a laser cutter. The challenge of using a laser cutter to cut acrylic is the thickness of the laser. The laser is 0.02" thick, so press fits need to be modeled as intersecting. Once the laser cutter is properly set up the 2D profiles of the models can be imported and cut out of the acrylic. Because of the inaccuracy of the laser some of the holes were cut slightly too large. Teflon tape was inserted into the holes to provide a tight fit and prevent the parts from moving. Two replacement knobs were manufactured to replace the current knobs on the TEE. These knobs were printed on the rapid prototyping machine because of their complex geometries. They also have teeth that mesh with the sensor gears and having teeth of the same material prevents excess wear. To attach the TEE to the base plate, two holes were drilled into the bottom of the TEE.

6.2.3 Adapter

In order to mount the sensor gear to the servomotor, an adapter (Figure 46) had to be produced. The complex geometry of the part dictated a need for CNC machining. The SolidWorks file used to design the adapter was loaded into a program designed to make NC code. NC code is the programming language CNC machines use to create parts. The program was then used to produce two codes for a 3-Axis Haas mill. The first code cut away material on the top face of aluminum stock to make all of the upper features, including the square shaft and spacer boss. The stock could then be flipped over in the mill to produce the bottom features and screw holes. Machining for both parts took around 6 hours.

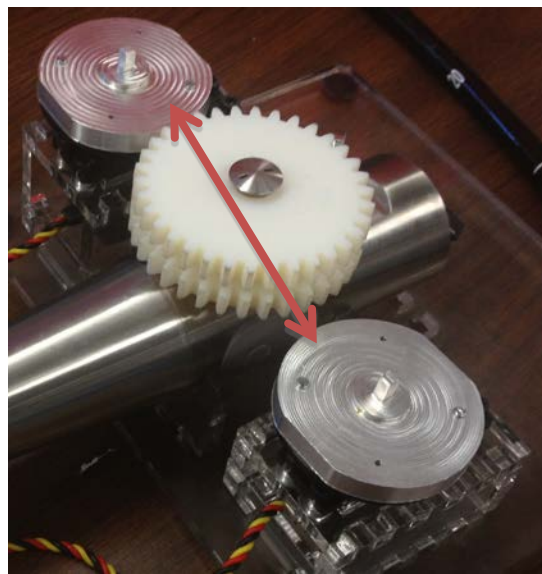

Figure 46: Image showing two of the adapters mounted on the prototype assembly.

6.2.4 Circuit Construction

The circuit was constructed with breadboards and wires. During the construction phase, a power supply was used before using the batteries as power source. The reason behind this choice is that the power supply is much more stable than batteries. In construction, different lengths of wires were used depending on the distance needed. The goal is to lower the complexity and avoid as many mistakes as possible.

Chapter 7: Testing and Results

7.1 Testing

After building the prototype, the next step is to test the prototype and verify that it is able to meet the project specifications. The goal of this project is to “research and design a feedback system capable of communicating the forces between the TEE probe and the wall of the gastrointestinal tract.” It is used to determine what kind of tests is required in order to measure the success of this project. In the end, four tests were used. They are: Determine Maximum Safe torque, Torque and Sensor correlation, Sensor Calibration and tip displacement tests. The “Determine Maximum Safe torque” test is different in that it is more used to help understand the system than verify whether the modified TEE works. The Torque and Sensor Correlation test is used to demonstrate that the system is able to communicate with the forces at the probe end and respond to the forces accordingly. The “Sensor Calibration” test is used to implement a better user interface and help the project meet its specifications. It also demonstrated that the LEDs are a reliable way to warn the users of possible danger. The Tip Displacement Test is used to demonstrate that the system is capable of maintaining the same amount of motion and function the original design does. Through these four tests, this system is then demonstrated to meet the task specifications mentioned in previous chapters.

7.1.1 Determine Maximum Safe Torque

An experiment was conducted to determine the maximum torque that can be applied to the TEE probe’s controls without endangering potential patients. Exceeding this threshold could endanger patients and cause injuries such as perforations to the esophageal wall, scratching or bruising. In addition to the safety concerns, the maximum safe torque value governs the power requirement of the drive system. The drive system must be powerful enough to provide maximum safe torque while also overcoming the frictional forces of the system. Since the necessary instruments to measure operational torque of the TEE probe are not available, an experiment had to be created that would provide the necessary information to calculate the maximum safe torque.

The TEE probe is equipped with a slip clutch system that prevents doctors from applying dangerous levels of torque when operating the TEE. When engaged, this slip clutch system causes a ratcheting effect in the controls. The maximum torque before the control ratchets into the next position is the maximum safe torque that can be applied to the TEE. It is this torque value the experiment has been designed to calculate.

The experiment uses a force gauge to calculate the amount of tangential force it takes to rotate each of the TEE control knobs. The perpendicular distance from the tangential applied force to the center of the respective knob multiplied by the force to turn the knob equals the torque required to turn the knob. Equation 1 restates this, showing the equation to calculate torque. For more details on the procedure of the experiment, refer to Appendix C.

$$T = r \times F$$

Equation 1: The equation for torque. T is the calculated torque, r is the perpendicular distance from the center of the torqued object to the tangentially applied force, and F is the amount of tangential force applied.

At the conclusion of this experiment it was determined the maximum safe torque to rotate the smaller knob was on average 1.39 in-lbf reaching with trials reaching a maximum torque of 1.64 in-lbf. The large knob was measured to have a maximum safe torque of 3.09 in-lbf with trials reaching torques up to 3.09 in-lbf. The measured forces and calculated torque values for the small knob and the large knob can be found in Table 12 and Table 13, respectively. These calculated torque values are the maximum safe torques that can be applied to the control knobs without harming a patient. Additionally, these results suggest how powerful the drive system should be for this project. Depending on the drive system chosen, the power can be reverse calculated from the maximum safe torque values.

1. Radius (in)	Force (lbf)	Torque (in-lbf)
0.75	1.63	1.22
0.75	2.06	1.55
0.75	1.75	1.31
0.75	1.94	1.45
0.75	2.19	1.64
0.75	1.75	1.31
0.75	1.69	1.27
Average		1.39
Max		1.64

Table 8: Force and torque results for the small knob of the TEE probe.

Radius (in)	Force (lbf)	Torque (in-lbf)
0.94	3.50	3.28
0.94	3.50	3.28
0.94	3.50	3.28
0.94	3.50	3.28
0.94	2.69	2.52
0.94	2.88	2.70
0.94	3.50	3.28
Average		3.09
Max		3.28

Table 9 : Force and torque results for the large knob of the TEE probe.

7.1.2 Correlation between Sensor Value and Torque

This test is used to determine whether there is any kind of relationship between the force input at the probe end and the sensor voltage value. As specified in the project goal, the modified TEE needs to be able to give the doctor an accurate feedback of how the probe actually feels. A torque sensor was designed to read the torque output at the drive system end, which was known to have a linear relationship to the force received at the tip.

A test procedure was implemented to conduct this test. In order to fully test the system, the entire prototype was constructed. As discussed in the prototype design chapter, a system capable of reading inputs and displaying outputs was built. By this test, the LEDs have not been fully implemented because they will require the sensor to work first. Everything was added to the prototype except the LEDs. Instead of using the LEDs, a software called PLX-DAQ was used to read from the Arduino board about the sensor output and record the data in an excel sheet. The data was recorded at a rate of 30 values per second. Several types of tests were conducted on the two sensors built. The first method begins with a five second count-down after the start of data collection. After the five second, the button for the selected sensor on the keypad was pressed to move the motor 90 degrees in one direction. After it reaches the 90 degrees, another button was immediately pressed to move the gear back 180 degrees to the opposite limit position. After that position is reached, the motor will be again controlled to return to its original position. Through this method, it is able to find out whether the sensor has a consistent correlation with torque throughout its full range of motion. In the second method the sensor data was recorded from its original position to one of the +/- 90 degrees position. The servo motor rotates in 6

degree increments. As the motor angle changes there is a 2 second waiting time to allow the sensor value to settle down. The increased waiting time in between steps allows for the correlation between motor angle and torque to be seen more easily. The excel data shows that the sensor has a consistent correlation with the torque input. A selected collection will be discussed here to demonstrate the testing outcome.

The first sensor is defined as the sensor which connects to PIN A1 on the Arduino board (Figure 47). This sensor was tested with the two methods mentioned above and with 2 separate approaches. The current TEE has two options when running: with and without the slip clutch. The first test discussed here uses method 1 (Figure 48), which allows it to run its full range of motion.

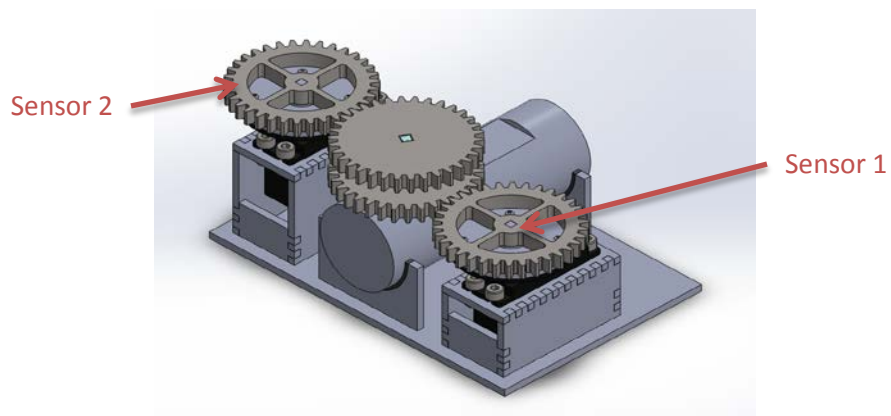

Figure 47: Modified TEE Detailing the Two Sensors

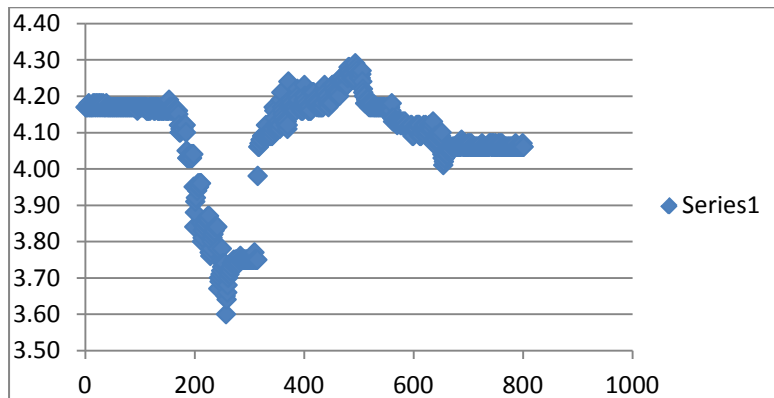

Figure 48: Graph of sensor 1 test without slip clutch enabled

When the testing started, the sensor stayed at a constant value which is about 4.18V. After the motor was turned in one direction, the sensor value increased almost linearly. A linear trend line was added to that specific part of the graph. It ends with an R-squared value of 0.871. After the motor reached its 90 degree maximum motion, it turns to the other direction. At the moment, there was understandably a jump in the torque as the motor turns around. For the other direction of the motor,

the same phenomenon happened. The difference is that the sensor is more responsive in one way than the other.

The second test done on the first sensor is to test the sensor with the slip clutch enables. That is, the same method as the first test will be used to let the motor run its full range of motion. However, the click effect would be turned on. It is expected that the sensor graph will have jumps every time the motor is turned. When the test finished, the testing result verified this expectation. Figure 49 shows a graph of the sensor value change across the time interval.

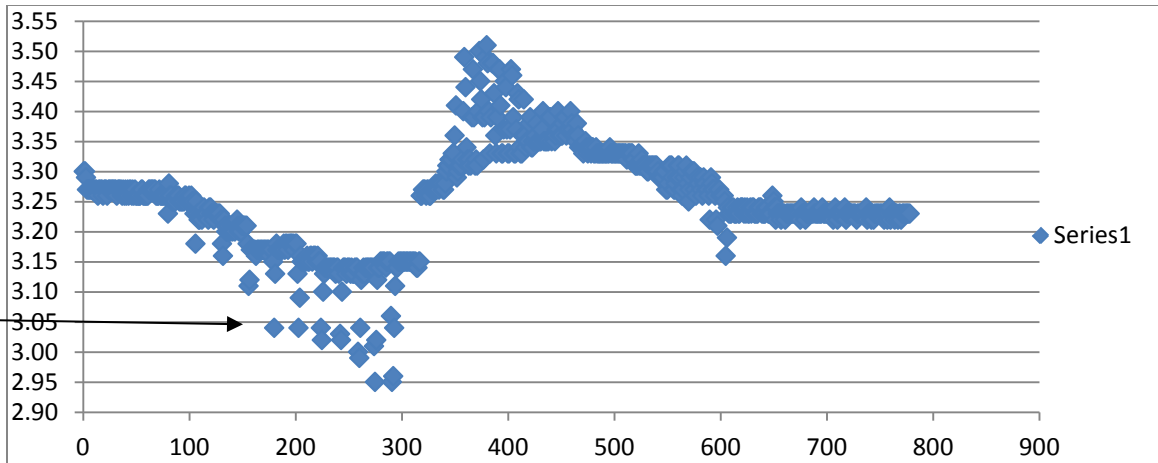

Figure 49: Graph of sensor 1 test with the slip clutch enabled

As shown in the graph of the test results the sensor value jumps to a higher value when it encounters the slip clutch. The sporadic points on the graph indicate the torque value jumps when the motor crosses each click. It is worth to mention that the sensor value jumps become greater as the motor getting close to its 90 degree position. There is more torque resistance as the motor departs from its original position. The slip clutch resistance also increases at the same time.

The third test performed on the first sensor uses a hand wrapped around the tip to mimic the esophageal wall. It is expected that the sensor value will change more given an additional force provided at the probe end. The motor will also be controlled to run its full range of motion. The slip clutch is disabled. Figure 50 shows the sensor value graph of the third test.

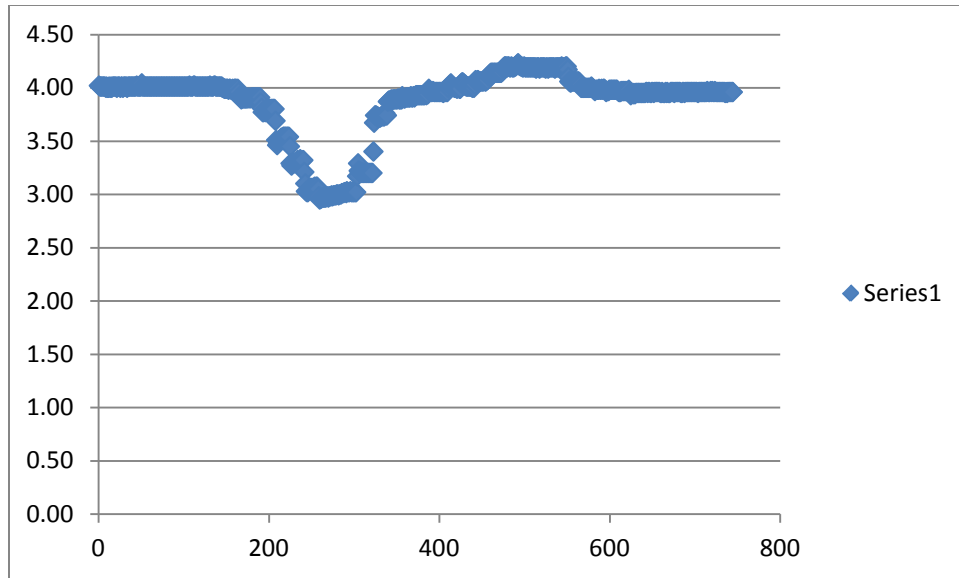

Figure 50: Graph of sensor 1 test with hand

During this test, the sensor values changed in the same way as the previous two tests. However, the sensor value range became much bigger than previous tests. During the first test which does not have a force at the probe, the sensor voltage difference ranges from 4.3v to 3.6v, resulting in a difference of 0.7v. During the third test, the sensor value ranges from 4.3v to 2.9v, resulting in a difference of 1.4v. The significant sensor value range change shows how much a force at the tip can influence the sensor output. In another words, the sensor is able to detect whether there is too much force at the probe end.

This concludes the testing discussion for the first sensor. For the second sensor, the same test procedures were used. The testing results of the second sensor have demonstrated the same concept. The only difference is that the sensor values are different. However, they all responded to the force change at the probe, TEE click and motor motion well.

In conclusion, the sensor designed met the goals of the project, which detect the force changes at the probe end and give a readable output to inform the user of the changes.

7.1.3 Sensor Calibration

Given a working sensor, the next step of the project is to represent the sensor values in a meaningful way to the user. As presented in the design, LEDs would be used for this purpose. LEDs were tested first to make sure they are fully functional. To test the LEDs, a program was written to light up LEDs one by one every second. After the LEDs all light up, they would run the cycle again. The testing was successful. With working LEDs, the next step is to program the LEDs to light up a certain amount of lights according to the sensor value.

In the test plan, the probe will stay at its original position. When the testing starts, one person will hold the end of the probe so that it cannot move, the other person will then control the motor to make it turn in a certain direction. In this way, one can collect data of the voltage values of the sensor. With this information, a program will be written to implement the LEDs accordingly. After the program is written, the test will run again, except that it has LEDs attached, which should display correct LED readings.

During the test the voltage values collected (Table 10 and Table 11). A motor can turn in two directions from its original position. It can increase 90 degrees clockwise or counterclockwise. By moving in either direction it will end up with either a minimum voltage value or a maximum voltage value. These two values are the safety thresholds for the probe. The LED will reach red at these two values. If the sensor values are closer to the origin value, the LEDs will reach either yellow or green. The LEDs will light up, independent of the direction of motion, when the maximum force has been reached.

Original Voltage =3.35 V	
Minimum Voltage =3.07V	Maximum Voltage = 3.46
Step Values:	Step Values:
1.3.31V	1.3.365V
2.3.27V	2.3.38V
3.3.23V	3.3.395V
4.3.19V	4.3.41V
5.3.15V	5.3.425V
6.3.11V	6.3.44V
7.3.07V	7.3.455V

Table 10: Sensor 1 calibration table

Original Voltage =3.18V;	
Minimum Voltage =2.91V	Maximum Voltages =3.54V
Step Values:	Step Values:
1.3.142V	1.3.231V
2.3.104V	2.3.282V
3.3.066V	3.3.333V
4.3.028V	4.3.384V
5.2.99V	5.3.435V
6.2.952V	6.3.486V
7.2.914V	7.3.537V

Table 11: Sensor 2 calibration table

Using these values, the LEDs ended up performing great. The LEDs worked as one pressures the probe end and represents the force applied in a meaningful way to the doctor. This test turned out to be successful. However, it is important to notice that these values need to be recalculated every time a test is done.

7.1.4 Tip Displacement Test

The tip displacement test determines whether the modified TEE maintains the same tip displacement as the original TEE. This test is important because one of the specifications for the project is that the motion of the TEE is not restricted by the modifications. The setup consists of taping the tip of the TEE to a table and placing a protractor at the bending point. The knob on the original TEE is turned to its maximum angle and the angle of the tip is recorded (Figure 51). This is repeated for both clockwise and counterclockwise rotation on both the yaw and pitch knobs (Figure 52). The original TEE is then replaced with the modified TEE and all the tests are repeated. The angles are compared and results are then concluded. The conclusion that can be drawn from this test is that the modification of the TEE did not affect the tip displacement in any way. The TEE maintains its full range of motion so the specification is met. The full test procedure can be found in Appendix F.



Figure 51: Displacement test of original TEE CCW yaw



Figure 52: Displacement test of modified TEE CCW yaw

7.2 Results

The major conclusion that can be extrapolated from the results of the tests is that the prototype works as a proof of concept. A major result is that the force at the tip is directly related to the torque at the knob. Another is that the modified TEE maintains the same motion as the current TEE, and a third is that the sensor measures the force at the tip. These results are major successes and are telling of the success of the project by themselves.

Most of the problems with the prototype emerged during testing. One of these issues was the unintended motion in the parts. This includes the wobbling of the gears and the housing. The gears could move approximately 6 degrees in either direction while the device was supposed to be stationary. This means that the correlations between motor angle and torque were difficult to find because the motor and the knob did not always rotate the same amount. It also adds to the inconsistency in the sensor readings. More inconsistency came from the circuit. The sensor circuit did not always have the same base voltage because the sensor value changed based on many factors including room temperature. These inconsistencies showed in the results. These tests prove that the sensor works as intended.

Chapter 8: Discussion

The prototype of the modified tee transducer satisfied all of the major design specifications. The final prototype itself consists of a standard TEE transducer probe, which has been modified by replacing the previous hand controls with gears. These gears are driven by sensor gears used in conjunction with servomotors. Incorporating the use of the original controls in the designs allows the prototype to maintain the same ranges of motion the current TEE device already maintains. When in operation, the sensor gear detects the increase of torque required to move the probe tip and relay's this information back to a microprocessor where it is processed. The prototype can then successfully communicate a precise force feedback to the user with accuracy independent from where the controls are placed. Currently the force feedback is displayed on an LED light bar that indicates if the force applied to the gastrointestinal tract is in a safe range or not. The processing power of the Arduino Mega ADK microcontroller allows this entire process to be completed almost instantaneously.

Although the final prototype can communicate the forces between the probe tip and the gastrointestinal tract to the operator, there is still vast room for improvement of the device. One of the major issues identified is the need for the prototype's programming to be calibrated every time the device is powered on. This is likely due to the use of breadboard circuitry, where even minute changes

will cause a change in measured voltages. The voltage difference between the two branches of the Wheatstone bridge changes every time the device is powered on. This change is then amplified by 400 times, increasing the error in the system. The device must be calibrated appropriately for the LED force feedback indicator to work correctly.

Another issue with the TEE is the resolution of the force feedback that is measured. This is mainly attributed to the gear sensor construction. The gear itself was manufactured using rapid prototyping. This method of manufacturing is great for producing custom parts, but lacks a specific modulus of elasticity. This adds to the complexity of dimensioning the sensor gear to have an optimum resolution for measuring the force feedback, decreasing the potential sensitivity of the sensor gear.

Operation of prototype also revealed backlash in the sensor gear and sensor gear adapter assembly. Backlash refers to a degree of play between parts of a mechanism. In our application, the backlash occurred when the adapter for the sensor gear rotated independently of the actual sensor gear. The source of the problem is due to size and shape of the fitting that attaches the gear sensor to the adapter.

Lastly, there were several problems that arose from the assembly of the prototype. The first assembly issue was that the motor cradle was not secure. When torque is applied to the gear system, the motor cradle has a tendency to move and change positions. This unintentional movement can cause decreases in the sensitivity of the gear sensor. The movement also changes how the gear sensor interacts with the replacement knob gears, causing changes in the sensor readings. In some instances, the movement is enough to allow gear teeth to “jump”. The second issue is overall dimensioning errors in the adapter and motor housing resulting in gear misalignment. The misalignment of the gears contributes to gear teeth “jumping” out of place.

Chapter 9: Recommendations

9.1 Housing Recommendations

The motor cradle moving is a large problem that needs to be addressed. One solution would be to glue it down, but this would prevent disassembly. The TEE is secured by using two screws attached to the base. The motor cradle could be secured in a similar way. There are already two screws attaching the motor to its cradle. These screws could be extended down through the base plate to hold the motor cradle to the base. The dimensions of the current cradle prevent this, so the entire housing would require redesigning. Securing the motor cradle is definitely a recommended course of action however as securing the motors to the baseplate is vital to the function of the device.

A second issue with the housing is how the other parts fit together. There is not a tight fit between the sensor gear and the adapter or between the knob replacements and the TEE. This issue is twofold. The first is that the manufacturing processes used did not have the necessary tolerances that are required to ensure a tight fit between parts. The second is that the rapid prototyped material wore away creating additional movement. Changing the material of all of the rapid prototyped parts to a metal like aluminum would solve both of these issues.

9.2 Circuit Board Improvements

There are many improvements that could be made to the circuit board to improve the overall performance of the product. As discussed earlier, there are several drawbacks to the current systems. One of the biggest drawbacks is that the sensor does not provide a consistent output, which makes it hard, if not impossible, to return a consistent feedback to the user. There are many causes of this problem. The circuit board design is one of the causes. The inconsistency in the circuit board causes the sensor value to vary. For example, one cannot balance the Wheatstone Bridge. Theoretically, the Wheatstone Bridge should have an output of zero when the testing starts since there is no output but this is not the case. A Wheatstone bridge calibration circuit which allows the user to zero the Wheatstone Bridge would increase the accuracy of the sensor. The other improvement the circuit board can have is to add an additional motor control circuit. Currently the servo motor rotates in increments of 6 degrees. A system could be implemented to allow the user to adjust the sensitivity of the servo motor by adjusting the number of degrees the motor moves with each increment. Other improvements could include using a printed circuit board to replace the current circuit board. Another improvement would be to use a printed circuit board [PCB] instead of a breadboard. A PCB would remove the small changes in resistance that occur in a breadboard and provide a more reliable circuit by preventing wires from

disconnecting. A PCB would also reduce the space taken up by the circuitry. This would reduce the footprint of the device.

9.3 User Interface Improvements

Currently, the project uses LEDs to represent the force received at the probe end. However, in real life, a doctor may not be able to read the LEDs when he is in surgery (Peszynski, 2012). Therefore, a tactile feedback system could be better for this application. The existing TEE has a knob driven mechanism. A possible tactile feedback system could mimic the design of a knob, which is already familiar to the doctors. The force feedback steering wheel is an example of a design that would implement this.

9.4 Gear Sensor Recommendations

The gear sensor could be improved in several ways. Currently, the strain gauges were attached to the gear sensor purely through glue and tape. In a better design, a groove of the size of the strain gauges could be carved out on the gear sensor or made during 3D printing. By placing the strain gauges in the groove, the strain gauges would be better protected and placed more consistently. The other improvement for the gear sensor is that more strain gauges could be attached to the gear sensor. The current sensor has a single strain gauge. Three more strain gauges could be attached to make a full Wheatstone bridge instead of a quarter bridge. A full Wheatstone bridge could provide a more stable and accurate change of sensor values to the user.

Chapter 10: Conclusions

The modified TEE prototype provides a viable method to extend the controls of the current TEE probe while maintaining necessary force feedback. Extending the existing mechanical controls is not feasible due to inaccurate and less precise forces translated back to the probe operator. The modified TEE prototype uses servomotors in conjunction with a sensor system determine and transmit forces between the esophageal wall and tee probe tip to a microcontroller. This microcontroller then outputs an interpretable signal, which can be used in a multitude of ways including visual force feedback and even integrated with a haptic controller. Extending the controls electronically allows for almost no loss in force feedback accuracy regardless of where the controls are placed.

Since the controls can be placed nearly anywhere and modified to fit numerous applications, the modified TEE device could provide a practical solution for eliminating extra personnel in the TEE procedure. This would be accomplished by mounting the modified TEE device's controls in an easily accessible location to the interventional cardiologist. The modified TEE control's permits the interventional cardiologist to move the probe tip precisely and safely since there is no loss of force feedback, removing the need for an echocardiologist to be present for the entire procedure.

References

- Adafruit Learning System. (n.d.). Force Sensitive Resistor Overview. Retrieved October 10, 2012, from Adafruit Learning System: <http://learn.adafruit.com/force-sensitive-resistor-fsr>
- Applied Measurements LTD. (n.d.). Torque Transducers & Torque Sensors. Retrieved October 12, 2012, from Applied Measurements LTD Website: <http://www.appmeas.co.uk/torque-transducers-and-torque-sensors.html>
- Edler, I., & Lindström, K. (2004). The History of Echocardiography. PubMed, 1565-1644.
- Instruments, T. (n.d.). MSP430 Specifications. Retrieved 2013, from Texas Instruments Corporation Web Site: <http://www.ti.com/lit/ds/symlink/msp430f2131.pdf>
- Johns Hopkins Hospital. (n.d.). Transesophageal Echocardiogram. Retrieved October 11, 2012, from The Johns Hopkins University, The Johns Hopkins Hospital, and Johns Hopkins Health System Web Site: http://www.hopkinsmedicine.org/healthlibrary/test_procedures/cardiovascular/transesophageal_echocardiogram_92,P07986/
- Kern, T. (2009). Engineering Haptic Devices. Berlin: Springer-Verlag.
- Kern, T. (n.d.). Engineering Haptic Devices. Springer.
- Koninklijke Philips Electronics N.V. (n.d.). 2D and Live 3D TEE xMATRIX Array. Retrieved October 8, 2012, from Koninklijke Philips Electronics N.V. Web Site: http://www.healthcare.philips.com/main/products/ultrasound/transducers/x7_2t.wpd
- Koninklijke Philips Electronics N.V. (n.d.). Live 3D Transesophageal Echo. Retrieved October 11, 2012, from Koninklijke Philips Electronics N.V. Website: http://www.healthcare.philips.com/in_en/products/ultrasound/technologies/live3d_tee_echo.wpd
- Koninklijke Philips Electronics N.V. (n.d.). Transducer Care and Cleaning. Retrieved from http://www.healthcare.philips.com/in_en/products/ultrasound/Transducers/transducer_care/index.wpd

Koninklijke Phillips Electronics N.V. (2012). Various TEE Probes [Photograph]. Retrieved from http://www.healthcare.philips.com/in_en/products/ultrasound/Transducers/transducer_care/index.wpd

Miller et al. (2003). Patent No. 6572547. US.

Murphy, S. L., Xu, J., & Kochanek, K. D. (2012). Deaths: Preliminary Data for 2010. Hyattsville, MD: National Vital Statistics Reports.

RCD, H.-T. (n.d.). HS-7975HB. Retrieved 2013, from Hi-Tec RCD Website: <http://www.hitecrd.com/products/servos/digital/premium-digital/hs-7975hb.html>

SCHMIDT Control Instruments. (n.d.). Tension sensor LTS-422. Retrieved October 12, 2012, from Hans-Schmidt.com: http://www.hans-schmidt.com/EN/products/tension_meter/stationary_electronic/multi-station_systems_3_rollers/lts-422_series/model_lts-422

Stanford Hospital & Clinics. (n.d.). Transesophageal Echocardiogram . Retrieved October 9, 2012, from Stanford Hospital & Clinics Web Site: <http://stanfordhospital.org/healthLib/greystone/heartCenter/heartProcedures/transesophagealEchocardiogram.html>

The Bug. (n.d.). Retrieved 2013, from Ultramotion Corporation Website: <http://www.ultramotion.com/products/bug.php>

University of California San Francisco. (n.d.). Diagnosing Heart Disease. Retrieved October 10, 2012, from University of California San Francisco Web Site: http://www.ucsfhealth.org/education/diagnosing_heart_disease/index.html

Yeadon, W. H., & Yeadon, A. W. (2001). Handbook of Small Electric Motors. Columbus, OH: McGraw-Hill.

Peszynski, M. (2012, September 10). Introduction to Project. (D. Nahill, B. Sancetta, & B. Zhang, Interviewers)

Texas Instruments. (n.d.). MSP430F449. Retrieved October 12, 2012, from Texas Instruments Corporation Web Site: <http://www.ti.com/product/msp430f449>

Sawicz, D. (n.d.). MAE 412 Home Page. Retrieved October 25, 2012, from Princeton University Website:
<http://www.princeton.edu/~mae412/TEXT/NTRAK2002/292-302.pdf>

Tech Info: Motors. (2010). Retrieved November 6, 2012, from EV Works Pty. Ltd. Website:
<http://www.evworks.com.au/tech/?section=motors>

Schmidt-Tension Meter Calibration. (2013). Retrieved Apr 19, 2013, from Schmidt Control Instruments:
<http://www.hans-schmidt.com/mirror/upload/1168500906.gif>

Typical Applications. (2013). Retrieved Apr 19, 2013, from Schmidt Control Instruments:
http://www.hans-schmidt.com/EN/products/tension_meter/general_information/about_typical_applications

Appendix A: Finite Element Analysis

Finite element modeling allows a stress to be applied to a computer model of our sensor gear and illustrate the resultant strain throughout the gear graphically. To ensure the sensor gear will work as designed, finite element modeling can be used to calculate acceptable dimensions for our sensor gear. The strain gauges to be used on the gear sensor are capable of measuring a maximum strain of 1800 micro-strain ($\mu\epsilon$). Therefore, the maximum strain in each spoke of our sensor gear should be calibrated to avoid exceeding 1800 $\mu\epsilon$ during operation of the TEE transducer. Due to variations in the young's modulus of the rapid prototyping machine, two finite element models were created to analyze the strain for the possible extreme values, 200 [ksi] and 300 [ksi]. Using finite element modeling, multiple design iterations were able to be completed to accurately calibrate sensor gear spokes to operate in this range, thus minimizing the time and cost of producing multiple prototypes.

The finite element modeling not only aids the design of the gear spokes, but also helps observe other areas of the gear that are susceptible to failure. The gear ring width (W_R) and the center hub (D_h) of the gear must be manufactured with adequate material to avoid deformation and stress fractures during operation. The dimension selected for W_r is crucial to minimal deformation of gear for optimum strain readings and prevent the gears from seizing.

Finite Element Modeling Procedure

1. Model Gear

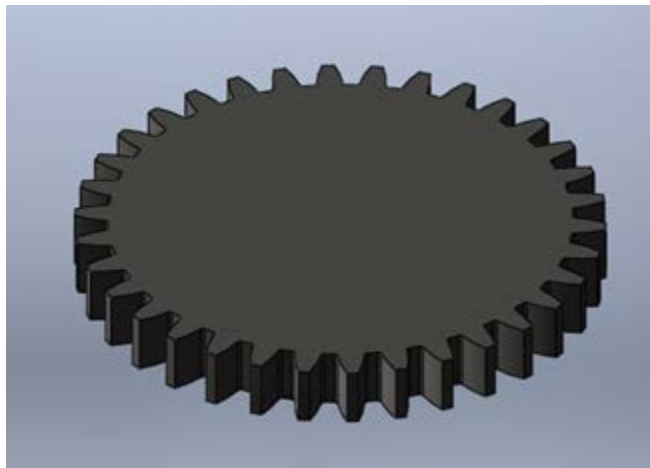

Figure 53: Toolbox Gear

2. Cut out material to create spokes. Note the small curve on the edge of the bore used to apply constraints.

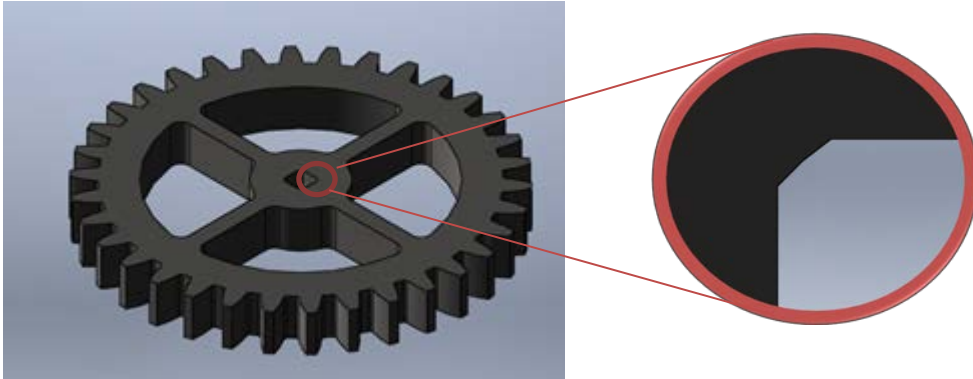

Figure 54: Spoked Gear (Left) and Detail of Curve (Right)

3. Apply Constraints

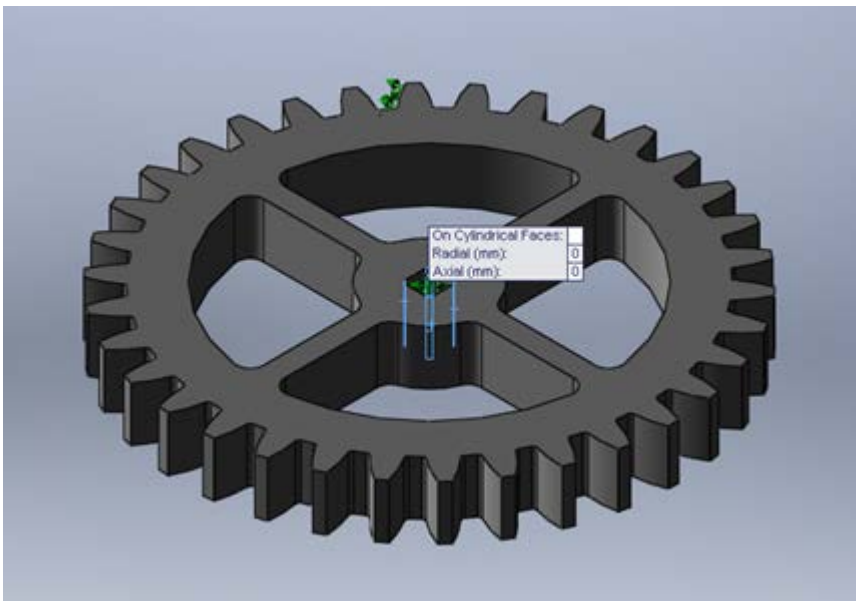

Figure 55: Cylindrical Constraints

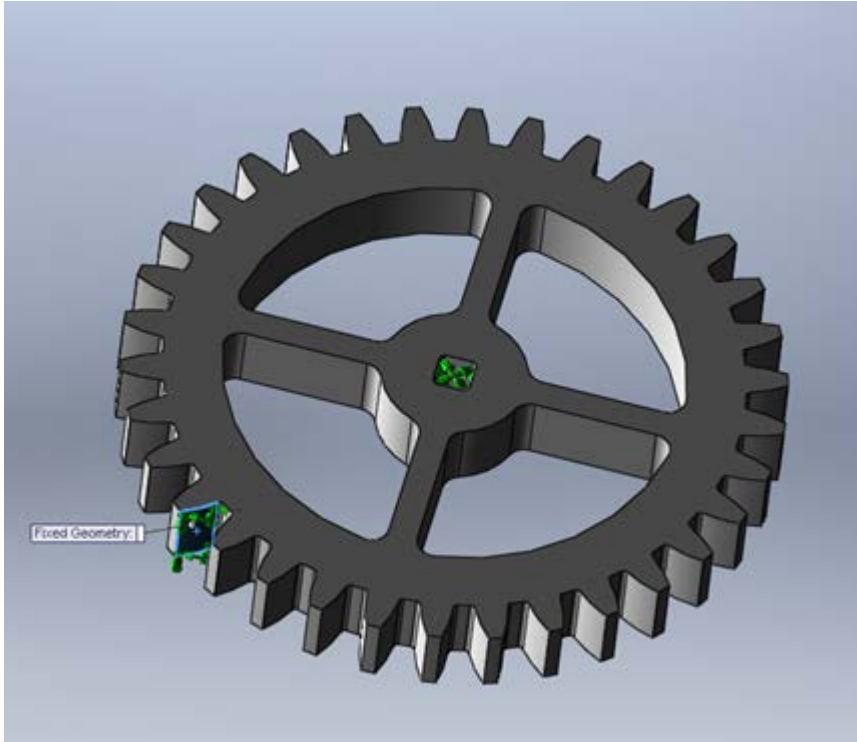

Figure 56: Tooth Constraint

4. Apply Loading

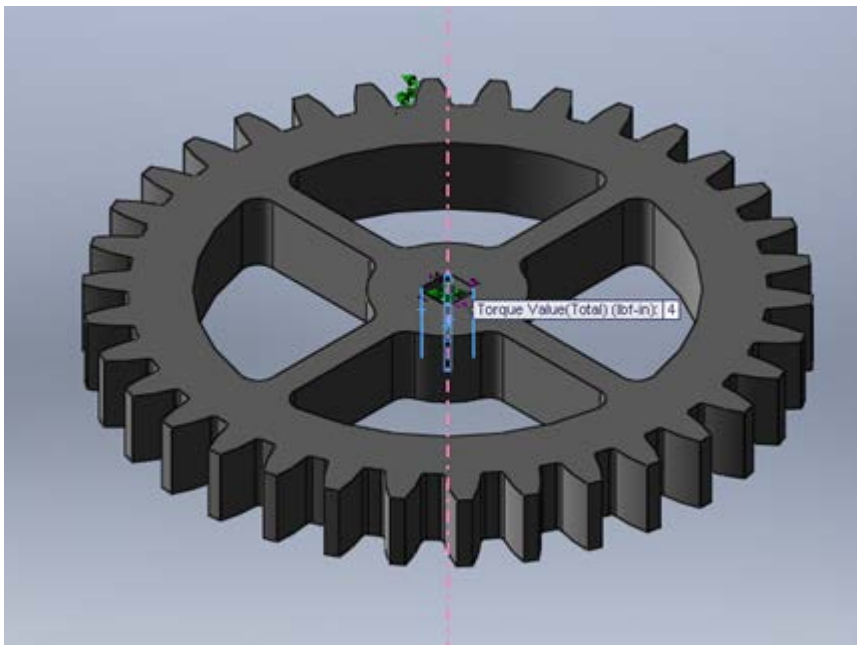

Figure 57: Loading

Results

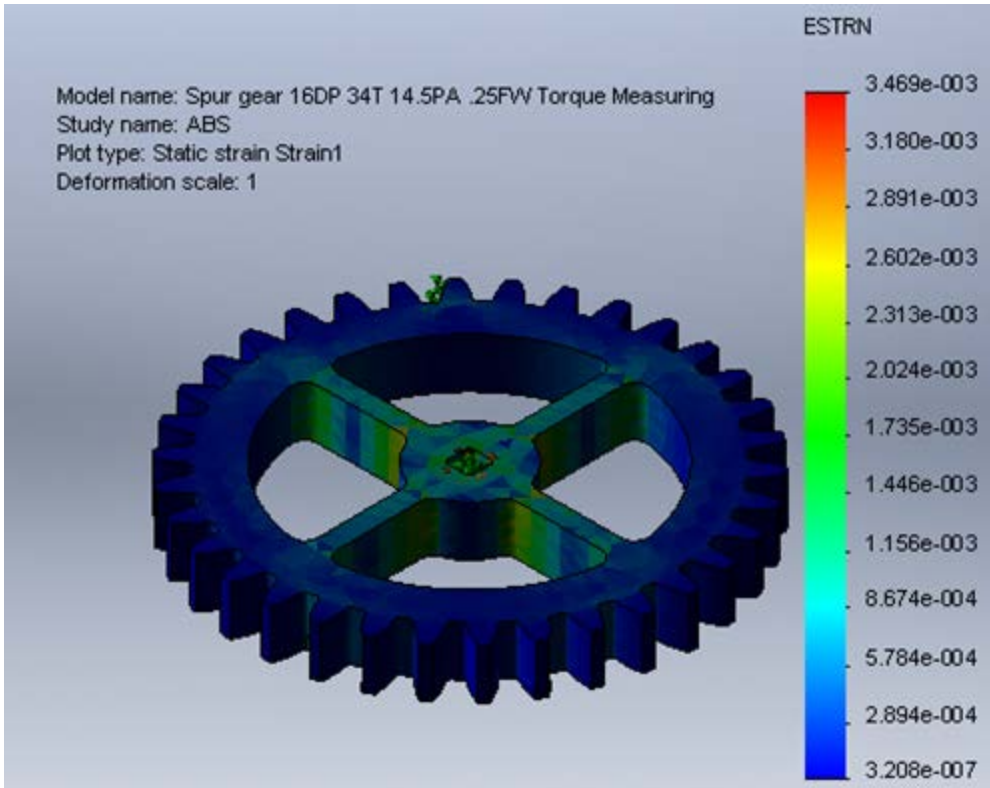

Figure 58: Strain, E=200ksi

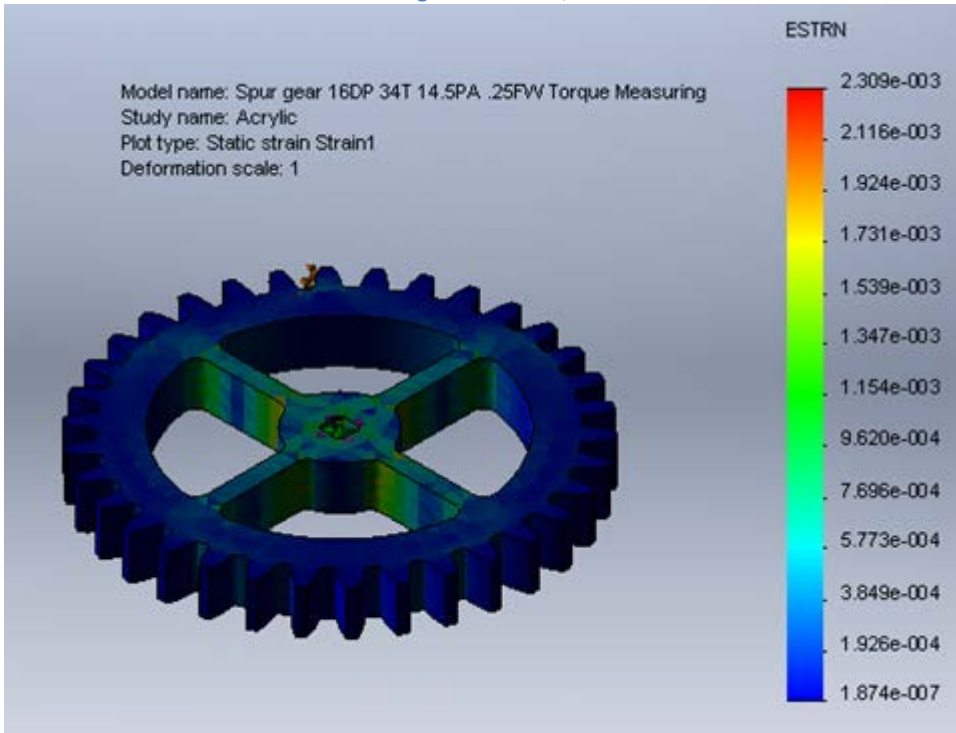

Figure 59: Strain, E=300ksi

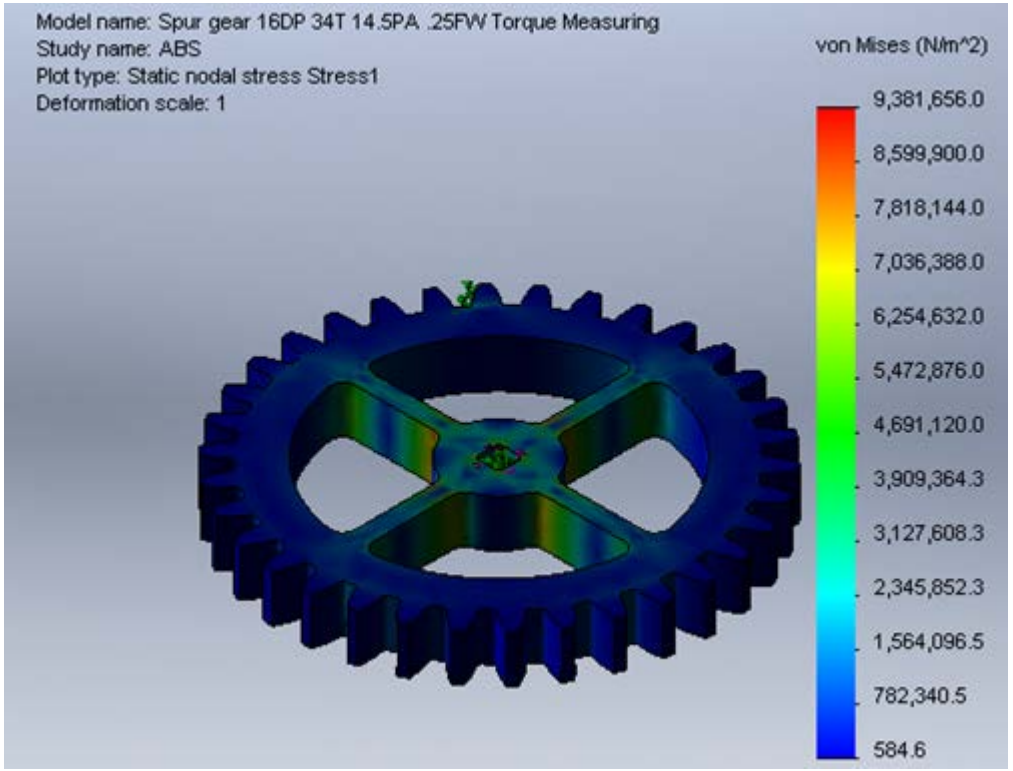

Figure 60: Stress, E=200ksi

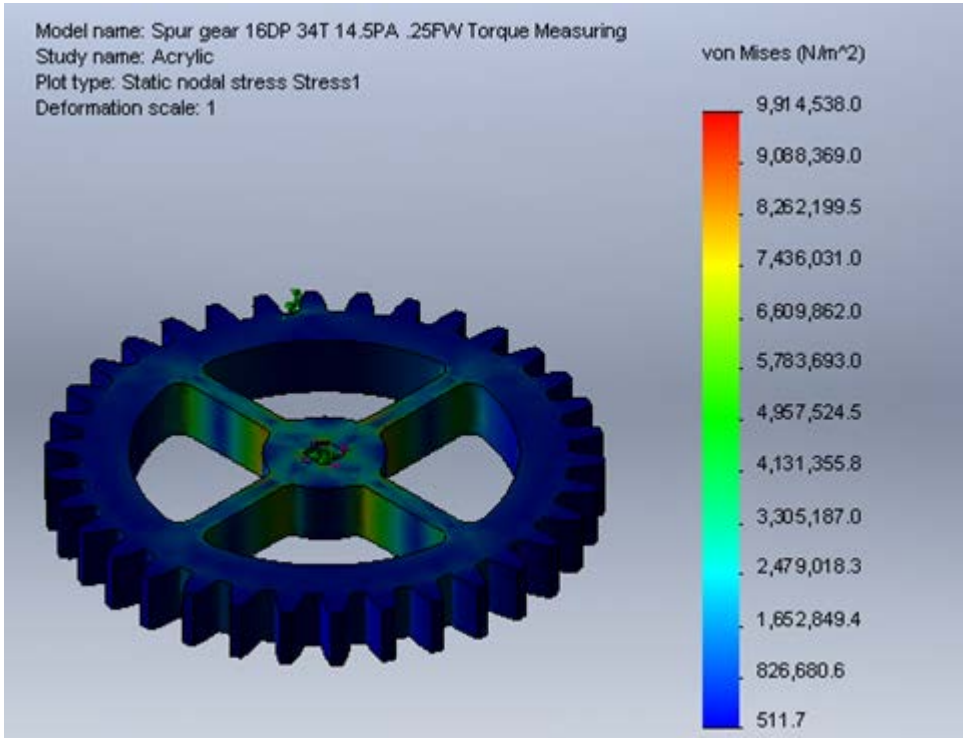

Figure 61: Stress, E=300ksi

The yield stress of the rapid prototyping material is 50MPa. The maximum stress is 5 times less, meaning it will not break under maximum loading. The stress measured was Von-Mises stress. Von-Mises stress is the equivalent stress in all directions, and is the standard for measuring yield stress.

Verification of the Finite Element Model

The finite element model is needs to be validated for accuracy. This can be accomplished by using stress analysis and modeling a gear spoke as a cantilever beam shown in Figure 14.

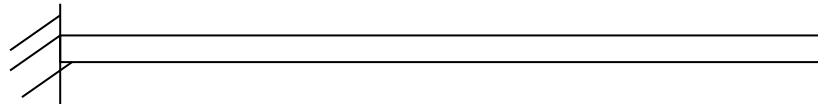

Figure 62: Stress Analysis Model for FEM Verification

The variables that need to be considered are the length (L), the thickness (t), the width (w), and the torque applied (M). Appropriate calculations for verifying the FEM are provided below in equations 1 through 6.

$$\varepsilon = \frac{\sigma}{E}$$

Equation 2

$$\sigma = \frac{M/4 \times t/2}{I}$$

Equation 3

$$I = \frac{wt^3}{12}$$

Equation 4

$$I = \frac{0.1 \times 0.25^3}{12} = 0.00013in^4$$

Equation 5

$$\sigma = \frac{\frac{M}{4} \times \frac{w}{2}}{0.00013} = \frac{\frac{4}{4} \times \frac{0.1}{2}}{0.00013} = 1538lb/in^2 = 10.6MPa$$

Equation 6

$$\varepsilon = \frac{\sigma}{E} = \frac{10.6MPa}{2.03Gpa} = 5.22 \times 10^{-3}$$

Equation 7

The stress analysis reveals a strain very similar to resultant strain from the FEM analysis. From this, it is known the FEM results can be trusted and used for further design.

Appendix B: Programming Code

```
#include <Servo.h>

#include <Keypad.h>

//Keypad constants

const byte ROWS = 4; //four rows

const byte COLS = 1; //three columns

//4 = left; 1= up; 7=right; 9=down

char keys[ROWS][COLS] = {

  {'4'},

  {'1'},

  {'7'},

  {'9'}

};

byte rowPins[ROWS] = {5, 4,6,7}; //connect to the row pinouts of the keypad

byte colPins[COLS] = {3}; //connect to the column pinouts of the keypad

Keypad keypad = Keypad( makeKeymap(keys), rowPins, colPins, ROWS, COLS );

//define constants for motor 1

int sensorPin = A1;

double voltage=0;

int row = 0;

Servo motor1;

int motor1pos=0;

int motorpin=30;
```

```
int servovalue;

//define constants for motor 2

int sensorPin2= A2;

double voltage2=0;

Servo motor2;

int motor2pos=0;

int motorpin2 = 36;

int desired2=0;

//potentiometer

int potPin=A5;

int potVal=0;

//LED pins

int ledPin = 44;

int ledPin2 = 46;

int ledPin3 =48;

void motor(int desired, Servo motor)

{ servovalue = desired;

  motor.write(servovalue);

}

void sensor1()

{ double sensorValue = analogRead(A1);

  voltage = sensorValue*5/1024;
```

```

//Serial.println(voltage);

Serial.print("DATA,TIME,");

Serial.println(voltage);

row++;

if(row>300000000)

{row =0;

Serial.println("ROW,SET,2");}

delay(1);}

void sensor2()

{ double sensorValue = analogRead(A2);

voltage2 = sensorValue*5/1024;

Serial.print("DATA,TIME,");

Serial.println(voltage2);

row++;

if(row>300000000)

{row =0;}

Serial.println("ROW,SET,2");}

delay(1);}

void ledlight1()

{ if (((voltage>=3.455) || (voltage<=3.07)) || (((voltage2>=3.537) || (voltage2<=2.914)))){

digitalWrite(ledPin, HIGH);

digitalWrite(ledPin2, HIGH);

digitalWrite(ledPin3, HIGH);

delay(10);}

```

```

else if
(((voltage>=3.44)&&(voltage<3.455))|((voltage<=3.11)&&(voltage>3.07)))|(((voltage2>=3.486)&&(v
oltage2<3.537))|((voltage2<=2.952)&&(voltage2>2.914))))))

{

digitalWrite(ledPin, HIGH);

digitalWrite(ledPin2, HIGH);

digitalWrite(ledPin3, LOW);

delay(10);}

else if
(((voltage>=3.425)&&(voltage<3.44))|((voltage<=3.15)&&(voltage>3.11)))|(((voltage2>=3.435)&&(v
oltage2<3.486))|((voltage2<=2.99)&&(voltage2>2.952))))))

{

digitalWrite(ledPin, HIGH);

digitalWrite(ledPin2, LOW);

digitalWrite(ledPin3, HIGH);

delay(10);

}

else if
(((voltage>=3.41)&&(voltage<3.425))|((voltage<=3.19)&&(voltage>3.15)))|(((voltage2>=3.384)&&(v
oltage2<3.435))|((voltage2<=3.028)&&(voltage2>2.99))))))

{digitalWrite(ledPin, HIGH);

digitalWrite(ledPin2, LOW);

digitalWrite(ledPin3, LOW);

delay(10);}

else if
(((voltage>=3.395)&&(voltage<3.41))|((voltage<=3.23)&&(voltage>3.19)))|(((voltage2>=3.333)&&(v
oltage2<3.384))|((voltage2<=3.066)&&(voltage2>3.028))))))

{

digitalWrite(ledPin, LOW);

```

```

digitalWrite(ledPin2, HIGH);

digitalWrite(ledPin3, HIGH);

delay(10);

}

else
if((((voltage>=3.38)&&(voltage<3.395))|((voltage<=3.27)&&(voltage>3.23))|((((voltage2>=3.282)&&(
voltage2<3.333))|((voltage2<=3.104)&&(voltage2>3.066))))))

{

digitalWrite(ledPin, LOW);

digitalWrite(ledPin2, HIGH);

digitalWrite(ledPin3, LOW);

delay(10);

}

else
if((((voltage>=3.365)&&(voltage<3.38))|((voltage<=3.31)&&(voltage>3.27))|((((voltage2>=3.231)&&(
voltage2<3.282))|((voltage2<=3.142)&&(voltage>3.104))))))

{

digitalWrite(ledPin, LOW);

digitalWrite(ledPin2, LOW);

digitalWrite(ledPin3, HIGH);

delay(10);

}

else {

digitalWrite(ledPin, LOW);

digitalWrite(ledPin2, LOW);

digitalWrite(ledPin3, LOW);

delay(10);

```

```

    }
}

void setup()
//setup timer and initialize it.
//attach motor to correct pins as output
//attach sensor pins as input
//attach user control pins as input
{Serial.begin(9600);
pinMode(motorpin,OUTPUT);
pinMode(motorpin2,OUTPUT);
motor1.attach(motorpin);
motor2.attach(motorpin2);

pinMode(ledPin,OUTPUT);
pinMode(ledPin2,OUTPUT);
pinMode(ledPin3,OUTPUT);
}

//1. Read the data from the sensor through analog read, which is a voltage.
//2. depending on different feedback methods, the loop can output an analog signal to an oscilloscope
to generate a visual voltage feedback;
//or it can use digitalWrite to blink an LED;or other outputs to control a haptic feedback device
//3. gets an digital input from the user controller
//4. output an signal to control the motor( myservo.write(val));

```

```
void loop() {  
char key = keypad.getKey();  
  
if (key == '1'){  
    motor1pos =motor1.read();  
    desired = motor1pos+6;  
    motorc = motor1;  
    motor2pos = motor2.read();  
    desired2 = motor2pos;  
}  
else if (key == '9'){  
    motor1pos=motor1.read();  
    desired = motor1pos-6;  
    motorc= motor1;  
    motor2pos = motor2.read();  
    desired2 = motor2pos;  
}  
else if (key == '4'){  
    motor2pos=motor2.read();  
    desired2 = motor2pos-6;  
    motorc = motor2;  
    motor1pos = motor1.read();  
    desired = motor1pos;  
}
```

```
else if (key == '7'){
  motor2pos=motor2.read();
  desired2 = motor2pos+6;
  motorc = motor2;
  motor1pos = motor1.read();
  desired = motor1pos;
}
else{
  motor1pos = motor1.read();
  desired = motor1pos;
  motor2pos = motor2.read();
  desired2 = motor2pos;
}

  motor(desired,motor1);
  delay(15);
  motor(desired2,motor2);
  delay(15);
  sensor1();
  sensor2();
  ledlight1();
}
```

Appendix C: Determining Maximum Safe Torque

Names: Dan Nahill, Ben Sancetta, Bangyan Zhang

Date: 04/22/13

Project Name: Haptic Feedback for TEE

Reason for Test: Determining Maximum Safe Torque

Method

2. Purpose:

This test is designed to determine the maximum amount of torque that can be applied to the TEE controls that is safe for the patient.

3. Background:

The current TEE has an integrated slip clutch system that prevents doctors from applying excess force to the esophagus when engaged. When the clutch system is engaged, the TEE controls will ratchet into positions. The torque required to turn the hand control immediately before the TEE control ratchets into the next position is accepted as the maximum safe torque that can be applied to the controls. This information can then be used to determine gear sizing and motor selection for the prototype TEE probe.

4. Procedure and Equipment:

Required Equipment:

- TEE Probe
- Vice
- (2) 6" of String
- 5 lb. Force Gauge
- Duct Tape
- Measuring Calipers

Procedure:

- a. Using a vice attached to a table, secure the TEE probe as seen in Figure 63.
- b. Ensure the safety threshold slip clutch is in the "engaged" position as seen in Figure 64.
- c. Attach a string to each of the knobs of the TEE probe as seen in Figure 65.
- d. Using the calipers, make note of the radial distance (from center to knot) of the string tied to the knob. Once completed, carefully secure the knot to the knob with duct tape as not to disturb the distance previously measured. Repeat for second knob. See Figure 66 and Figure 67.
- e. Using the side of the string not attached to the knob, create a loop for the force gauge to attach to. Repeat for second knob.

- f. Using the force gauge, pull a string tangential to its respective control knob. Repeat 5 times for each knob, taking note of the maximum tangential force before control knob ratchets into next position. This is demonstrated in Figure 68 and Figure 69.

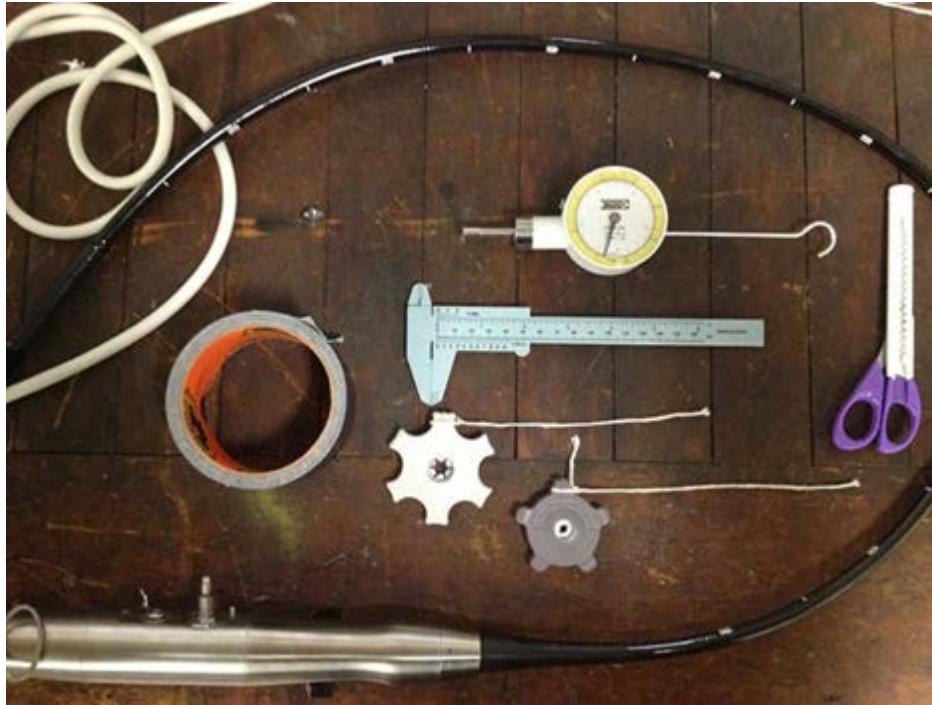

Figure 63: Materials needed for experiment include a TEE probe, duct tape, (2) 6" string, and a 5 lb. force gauge.



Figure 64: Illustrates the "on" position for the safety slip clutch.

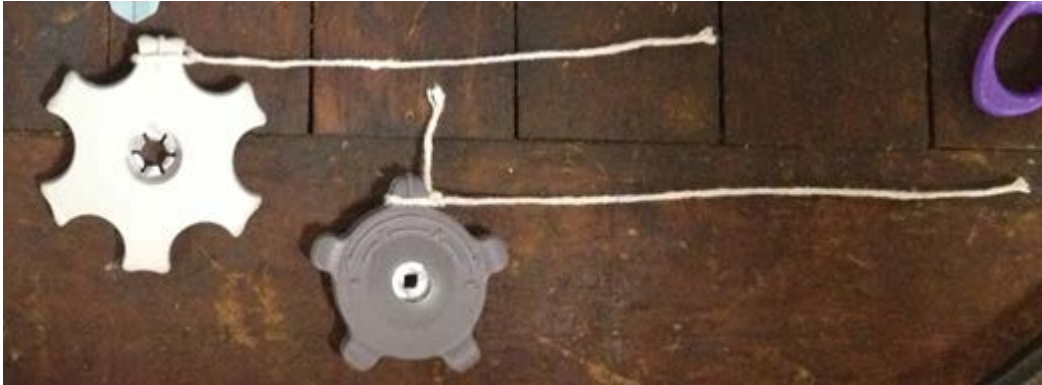

Figure 65: Strings should be attached to each force gauge as shown.

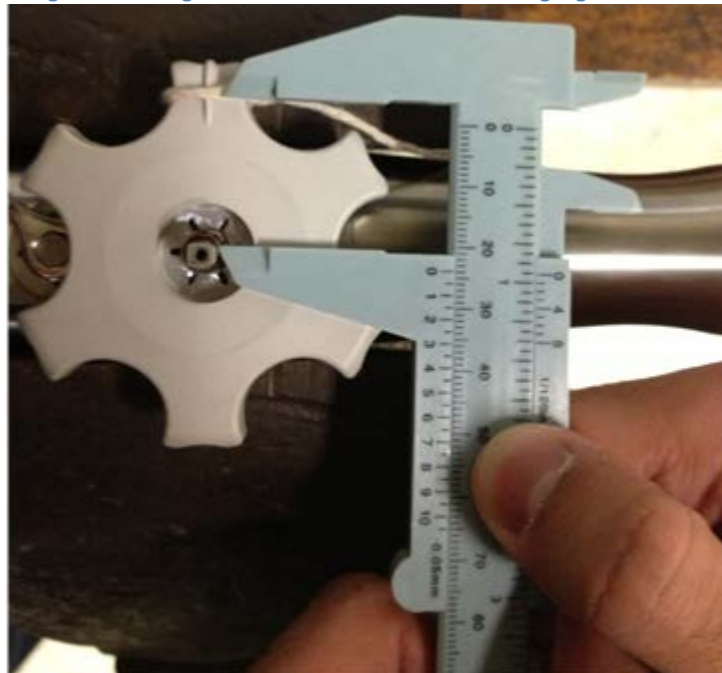

Figure 66: Measuring the distance from the center of the large knob to the string tie. String should be carefully secured at measured distance with duct tape

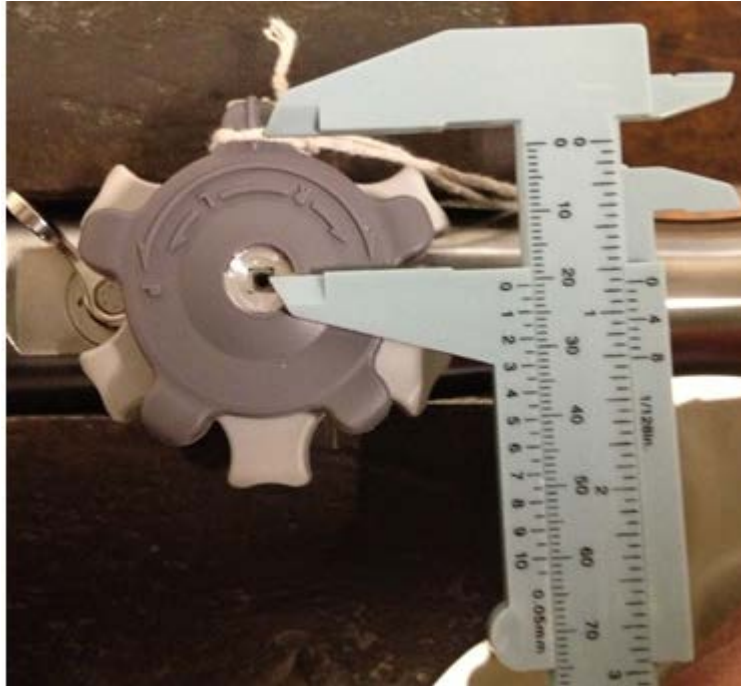

Figure 67: Measuring the distance from the center of the small knob to the string tie. String should be carefully secured at measured distance with duct tape.



Figure 68: Illustrates measuring the safe torque value for large knob. Notice string is pulled tangentially to knob.



Figure 69: Illustrates measuring the safe torque value for small knob. Notice string is pulled tangentially to knob.

5. Results:

At the conclusion of this experiment it was determined the maximum safe torque to rotate the smaller knob was on average 1.39 in-lbf reaching with trials reaching a maximum torque of 1.64 in-lbf. The large knob was measured to have a maximum safe torque of 3.09 in-lbf with trials reaching torques up to 3.09 in-lbf. The measured forces and calculated torque values for the small knob and the large knob can be found in Table 12 and Table 13, respectively. These calculated torque values are the maximum safe torques that can be applied to the control knobs without harming a patient. Additionally, these results suggest how powerful the drive system should be for this project. Depending on the drive system chosen, the power can be reverse calculated from the maximum safe torque values.

6. Radius (in)	Force (lbf)	Torque (in-lbf)
0.75	1.63	1.22
0.75	2.06	1.55
0.75	1.75	1.31
0.75	1.94	1.45
0.75	2.19	1.64
0.75	1.75	1.31
0.75	1.69	1.27
Average		1.39
Max		1.64

Table 12: Force and torque results for the small knob of the TEE probe.

Radius (in)	Force (lbf)	Torque (in-lbf)
0.94	3.50	3.28
0.94	3.50	3.28
0.94	3.50	3.28
0.94	3.50	3.28
0.94	2.69	2.52
0.94	2.88	2.70
0.94	3.50	3.28
Average		3.09
Max		3.28

Table 13 : Force and torque results for the large knob of the TEE probe.

Appendix D: Correlation between Sensor Value and Torque

Names: Dan Nahill, Ben Sancetta, Bangyan Zhang

Date: 04/22/13

Project Name: Haptic Feedback for TEE

Reason for Test: Determining the relationship between torque and sensor

Method

7. Purpose:

The test is designed to determine whether there is a relationship between the sensor value reading and the torque of the gear.

8. Background:

One of the design specifications states that the sensor needs to provide an accurate reading of the force received at the probe end, which was then transformed into the torque at the drive mechanism. When a force is applied at the probe end, the sensor reading should change accordingly. The sensor value should settle down after the force is removed. The sensor needs to be able to detect the safety threshold of the force at the probe.

9. Procedure and Equipment:

Required Equipment:

- Modified TEE
- Laptop
- Sensor

Procedure:

- a. Setup the system ; make sure everything is connected; open PLX-DAQ in excel
- b. Start recording data in excel through PLX-DAQ
- c. Wait for 5 seconds for the sensor values to settle
- d. Turn the motor clockwise by 90 degrees; monitor the sensor value at the same time
- e. Turn the motor back 180 degrees
- f. Turn the motor back to its original position
- g. Finish recording data
- h. Repeat the procedures from a to g; use hand to hold the probe end
- i. Repeat the procedures from a to g; turn on the click on the TEE

10. Results

The sensor is able to provide readings that are in relationship to the force received at the probe end. It meets all the goals mentioned in the background part of this testing strategy.

Appendix E: Sensor Calibration and Testing

Names: Dan Nahill, Ben Sancetta, Bangyan Zhang

Date: 04/22/13

Project Name: Haptic Feedback for TEE

Reason for Test: Calibrate the sensor so that it can be used to display reasonable LEDs responses

Method

11. Purpose:

The test is designed to calibrate the sensor so that the sensors can be used as an indicator for the LEDs to alert the user.

12. Background:

As stated in the project specifications, the user interface needs to be able to reflect the changes in sensor readings and alert the user about them. The LEDs should have green lights as normal sensor readings, yellow lights as warnings and red lights as alerts.

13. Procedure and Equipment:

Required Equipment:

- Modified TEE
- LEDs
- Sensor
- Laptop

Procedure:

- a. Set up the TEE correctly; Connect to the laptop
- b. Start recording data in excel through PLX-DAQ
- c. Wait for 5 seconds for the sensor values to settle
- d. Turn the motor clockwise by 90 degrees; monitor the sensor value at the same time
- e. Turn the motor back 180 degrees
- f. Turn the motor back to its original position
- g. Finish recording data
- h. Program the LEDs according to the collected data
- i. Repeat step a-g with LEDs attached to the microcontroller

14. Results

The result of the experiment is successful. The LEDs are able to show the change in the force input at the probe end and alert the user.

Appendix F: TEE Tip Displacement Testing

Names: Dan Nahill, Ben Sancetta, Bangyan Zhang

Date: 04/22/13

Project Name: Haptic Feedback for TEE

Reason for Test: TEE Tip Displacement

Method

15. Purpose:

This test is designed to ensure that the tip displacement of the modified TEE is the same as the original, unmodified TEE.

16. Background:

One of the design specifications dictates that the tip displacement must be the same in the modified TEE as it is in the original, unmodified TEE. When the knobs are turned, the tip rotates corresponding amount. When the knob reaches its limit the tip ceases to rotate. This test verifies that that point is the same.

17. Procedure and Equipment:

Required Equipment:

- Unmodified TEE Probe
- Modified
- Vise
- Protractor
- Tape

Procedure:

- g. Secure the unmodified TEE to the table using the vise
- h. Tape the protractor to the table
- i. Tape the tip of the unmodified TEE to the table so that the point of rotation is in the center of the protractor
- j. Rotate the yaw knob clockwise to the point of maximum rotation and record the result
- k. Repeat step d for the counterclockwise direction
- l. Repeat steps d and e for the pitch knob
- m. Repeat steps d, e, and f for the modified TEE



Figure 70: Displacement test of original TEE CCW yaw

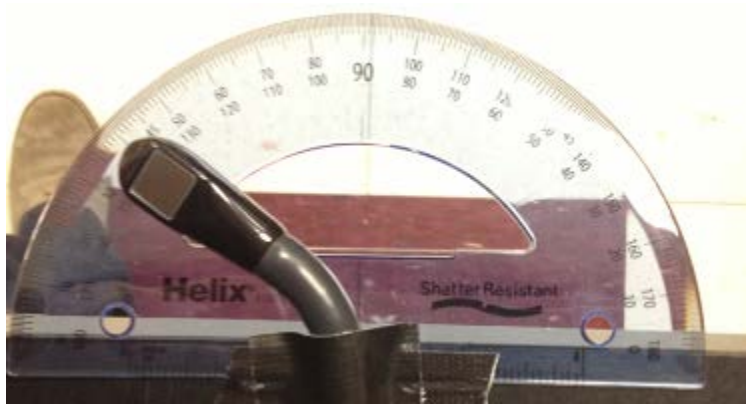

Figure 71: Displacement test of modified TEE CCW yaw



Figure 72: Displacement test of original TEE CW yaw



Figure 73: Displacement test of modified TEE CW yaw



Figure 74: Displacement test of original TEE CCW pitch



Figure 75: Second image of displacement test of original TEE CCW pitch



Figure 76: Displacement test of modified TEE CCW pitch



Figure 77: Displacement test of original TEE CW pitch



Figure 78: Displacement test of modified TEE CCW pitch

18. Results:

The conclusion that can be drawn from this test is that the modification of the TEE did not affect the tip displacement in any way. The TEE maintains its full range of motion so the specification is met.