

Worcester Polytechnic Institute Digital WPI

Major Qualifying Projects (All Years)

Major Qualifying Projects

April 2012

College Prep Teaching Modules -- A New Viewpoint

Russell Hayden Varney
Worcester Polytechnic Institute

Follow this and additional works at: <https://digitalcommons.wpi.edu/mqp-all>

Repository Citation

Varney, R. H. (2012). *College Prep Teaching Modules -- A New Viewpoint*. Retrieved from <https://digitalcommons.wpi.edu/mqp-all/1712>

This Unrestricted is brought to you for free and open access by the Major Qualifying Projects at Digital WPI. It has been accepted for inclusion in Major Qualifying Projects (All Years) by an authorized administrator of Digital WPI. For more information, please contact digitalwpi@wpi.edu.



College Prep Teaching Modules

A New Viewpoint

An Major Qualifying Project Proposal: submitted to the Faculty of
WORCESTER POLYTECHNIC INSTITUTE
In partial fulfillment of the
Degree of Bachelor of Science
by:

Russell Varney
russvarney16@wpi.edu

Date: April 26, 2012

Faculty Advisors:

Professor William Martin

Professor John Goulet

Contents

Abstract	3
Introduction	4
Selected Models.....	7
Goals	10
Imaginary Numbers.....	17
Intro to Imaginary Numbers	20
Logarithms	23
Introduction to Logarithms	26
Series.....	31
Pizza and Geometric Series.....	34
Sequences	43
Introduction to Sequences	45
Trigonometry	48
Discovering Trigonometry.....	50
Results.....	55
Bibliography	59
Appendix A.....	62
Evaluation Results.....	62
Appendix B	67
Evaluations.....	67
Appendix C	73
Trigonometry Module Tool	73

Abstract

Research shows that mathematics education in the United States is struggling to keep up with the rapid growth in Science, Technology, Engineering, and Math (STEM) career opportunities. This issue is especially apparent in secondary education. This project outlines several viewpoints on the best practices in college preparatory mathematics courses. After an extensive amount of research and analysis, examples of teaching modules have been created to enhance a high school student's experience, while better preparing him/her for college level courses. This concentration in mathematics touches on key topics such as sequences, series, and trigonometric functions. Each topic is outlined using high school and college level applications. Data summarizing classroom experiments performed on high school students justify the necessity and highlight the success of a new way of thinking in mathematics.

Introduction

In February of 2012, the President's Council of Advisors on Science and Technology (PCAST) sent a report to President Barack Obama that outlined the current state of Science, Technology, Engineering, and Mathematics (STEM) education in the United States. The shocking results of the committee's research show that STEM education in the United States is in significant need of repair, as they explain:

“Better teaching methods are needed by university faculty to make courses more inspiring, provide more help to students facing mathematical challenges, and to create an atmosphere of a community of STEM learners. Traditional teaching methods have trained many STEM professionals, including most of the current STEM workforce. But a large and growing body of research indicates that STEM education can be substantially improved through a diversification of teaching methods.” (Holdren & Lander, February, 2012)

Although bold, the statement tells the country a great deal about the current mentality in science and mathematics education. It is in need of change. The same committee conducted a study in 2011 on students taking the ACT (American College Testing) Exam. They found that eighty three percent of high school seniors are either not proficient in mathematics or not interested in STEM (Holdren & Lander, February, 2012). With a technology-reliant economy that is getting more advanced by the day, America cannot afford to only have seventeen percent of high students graduate with talent and interest in STEM. America falls short of keeping up with its economic growth in STEM careers by approximately one million people per year (Holdren & Lander, February, 2012). Yet, the issue stretches beyond secondary education. As of February, 2012, STEM majors in higher education have a retention rate below forty percent (Holdren & Lander, February, 2012).

Several organizations have been formed in direct response to research similar to that of PCAST. Their missions are simply to, “improve mathematics education in US public secondary schools” (Simons,

2012). Math for America is an example of one organization that provides support, resources, ideas, and the latest news in education. In the November 15, 2011 issue of the Huffington Post, Christopher Emdin, an urban education expert, explains to readers that the students are not at fault:

“Students are bored, don't find the topics being discussed as engaging, and opt for majors and interests in other disciplines. For those who are engaged in science classes, and are doing well in them, the nature of the instruction and the assessments often reflect more of an ability to memorize facts and sit attentively than truly actually engage in science. For these students, when they are faced with ‘true science’ further along in their academic careers, they are underprepared for the creativity, analytical skills, and curiosity necessary to truly engage and be successful.” (Emdin, 2011)

Furthermore, Emdin references the latest Department of Commerce report, which indicates that career opportunities in STEM fields are increasing at a faster rate and offer higher salaries than non-STEM careers (United States Department of Commerce, 2011).

All around the world, teachers are searching for solutions. At the University of Plymouth, Jackie Andrade believes that doodling is the solution to the STEM block. She argues that doodling increases students’ focus. Her research illustrates a twenty nine percent increase in retention with those students that doodle while contemplating a difficult problem (Andrade, 2009). In Toronto, John Mighton proved the success of his program: “Jump Math”. His data argues that approaching mathematics in small steps is successful because it builds a student’s confidence, while reinforcing concepts (Mighton, 2011-2012). In Massachusetts, the department of education has found that standardized testing is the most viable option. Currently, tenth grade high school students take the Massachusetts Comprehensive Assessment System (MCAS) Exam, which tests their basic knowledge of history, English, mathematics, and science (Massachusetts Department of Elementary & Secondary Education, 2011). All students must pass this

test in order to receive their high school diploma. Meanwhile, Faye Ruopp and Paula Poundstone argue that students lose interest in their elementary years. Their experiences gave them the motivation to create The Math with a Laugh Series. These books take lessons such as the slope of a line and make stories with funny titles such as, “What Are the Odds of Slope Being Tossed on His Head?” (Ruopp & Poundstone, 2007).

Does the mathematics revolution need help? Can professors and teachers possibly conduct too much research on the best practices in mathematics education? After months of investigation by some of the top education and engineering professionals in the United States such as Eric Lander (President, Broad Institute of Harvard and MIT), Maxine Savitz (Vice President, National Academy of Engineering), Richard C. Levin (President, Yale University), Christine Cassel (President and CEO, American Board of Internal Medicine), and Eric Schmidt (Executive Chairman, Google, Inc.), it has been concluded that, “...evidence-based teaching methods are more effective in reaching all students...” (Holdren & Lander, February, 2012).

On March 13, 2012, seventy students enrolled in Algebra II were asked, “What does a sine curve look like?” Nineteen students answered the question by drawing some sort of oscillating function. On the same test, students were asked to tell the difference between sine and cosine. Fourteen students referred to trigonometric applications to triangles, while another student stated, “I forgot, I learned last year. I know how to figure it out on my calculator.” On March 3, 2012, three Algebra II classes, totaling seventy three students, were asked to calculate the logarithm of one hundred, base ten. There was a test scheduled for the following Tuesday which would evaluate their knowledge on a previous chapter which included logarithms. Less than half of the students answered the question correctly. One student simply answered the question, “I do not have my calculator.”

Does the mathematics revolution need help?

Selected Models

There are several models that have been created with the purpose of improving mathematics education. The research for this project analyzed four different models. One model focuses on entertainment in lower level mathematics. The second utilizes a student's imagination, with several applications. The third model comprises higher level mathematics in a script format. The final model emphasizes the importance of discovery and confidence of a math student. These models have varying philosophies but each gives evidence that proves success.

Math with a Laugh Series, Fraction Stories, and Math Board Games are all examples of books that make mathematics fun. In these books, authors such as Poundstone use catchy titles and humorous stories to grasp students' attention. "Pass the Waffles, Please, Pocahontas"; "What Are the Odds of Slope Being Tossed on His Head?"; and "Divide or Be Devoured" are all examples of lesson titles from the Poundstone and Ruopp series of mathematics books (Ruopp & Poundstone, 2007). Although the lessons only apply to mathematics at or below a typical Algebra I course, the ideas are applicable to all ages. Overall, their lessons help students work through math problems while having fun. The emphasis on humor helps students forget that they are working through math problems. Poundstone describes the struggles she had and how her solution helps students like her:

"I can remember, when I was a kid, I'd get a word problem, something like: 'Mary had four apples. She shared two of them with Joe. How many does she have left.'

Although I could calculate the remaining apples, I mostly wanted to know more about Mary and Joe and would often include that curiosity in my homework. Were they just friends? How did Mary get the apples? Why couldn't Joe take care of himself? What is it with Joe? Was that even his real name?"

Math with a Laugh takes advantage of creative minds. The board games and fraction stories also have great examples of students having fun and using their natural, competitive minds.

Jackie Andrade is another woman that researched a very original technique to get students' attention. She calls this technique doodling. Although the idea is not new, the research is quite recent. After extensive research, Andrade found that there is a twenty nine percent increase in retention by doodlers (Andrade, 2009). Doodlers are those who draw their ideas in various pictures and charts at times where a concept is becoming boring or complex. Although it seems to be a way of distracting individuals, Andrade's study proves that it can also be quite the contrary. She found that doodling gives the students that may lose focus a way to refocus. The study even went beyond a general setting and found similar results in the classroom.

Perhaps the most subtle model of these four is Imre Lakatos's Proofs and Refutations. In this book, Lakatos creates a dialogue between students and their teacher. The group is continuously debating a proof that takes the reader into very complex concepts. Although the concepts exceed those taught in high school courses, the mathematical language proves to be beneficial. Even if students only make sense of one concept from a chapter of reading, the intellectual challenge remains advantageous. This dialogue can be used in a classroom for students who wish to act out different parts. This reinforces the ideas and gets students involved in the learning process. Dramatic reenactment of this dialogue may inspire some teachers to employ drama in the classroom in a new way.

The final model is John Mighton's Jump Math. Mighton believes that students are being asked to make their own discoveries in mathematics before they understand the basic concepts. This is why he created a way to teach math that exemplifies a ladder. The ladder philosophy focuses on guided discovery and confidence. Mighton provides what he calls "painstaking guidance" to students. He does this by giving students a small drop of knowledge at a time. These slow, continuous steps help students

make discoveries without realizing the significant progress that they have made. This progress leads to success and eventually helps build a student's confidence.

The statistics on John Mighton's Jump Math program speak highly of building student confidence through success. With Mighton's philosophy, Mary Jane Moreau was able to move her fifth grade class from the sixty sixth percentile to the ninety second percentile in just one year. (This percentile ranking refers to a norm-referenced Test of Mathematical Abilities.) In 2009, Ms. Moreau's class improved from the fifty fourth percentile to the ninety eighth percentile with the help of Jump Math (Bornstein, 2011).

The modules created in this project have been designed to utilize some of the best practices which proved to be successful in the four models discussed previously. The best practices were identified as entertainment, imagination, dialogue, discovery, and confidence.

Goals

The following teaching modules have been created in order to improve the experiences of high school students in their mathematics courses. There are several factors that go into a typical high school lesson plan. The factors identified in this project as positive contributors to successful math lessons are student interest, discovery, and retention. The focus of these modules is to achieve these goals while following the Massachusetts Curriculum Framework. The biggest challenge is to complete all of these requirements, while giving high school students the tools necessary to be well-prepared for college level mathematics. The desired result is to have students both confident and competent in mathematics.

This investigation focuses on three themes in maintaining student interest: applications, hands-on learning, and entertainment. Many high school students have mathematics engrained in their head as an evil subject that is no longer applicable after basic geometry and algebra. Emdin says that one of the “5 reasons that youth are unlikely to have careers in STEM fields” is because math lost the “cool factor” (Emdin, 2011). Furthermore, students do not find the subject to be useful.

The modules in this project are designed to solve this by discussing applications. Any application is not enough. It is essential that the applications relate to students through experience, current events, or general interest. Uninteresting applications are just as impractical as over-complicated applications. One must strike a careful balance to ensure that the lesson is still mainly mathematics. The underlying mathematics cannot be obscured by definitions and terminology from another subject. Over-complicated examples can frustrate students. Furthermore, these examples tend to steer away from the topic-at-hand and do not necessarily result in a better understanding.

An example of an application used in this project originates from the calculations used to define the Richter scale. This application allows students to see a practical use of logarithms while keeping the calculations fairly simple. Moreover, the data used for this module comes from recent earthquake

activity. A great resource for teachers to find more applications is the Consortium for Mathematics and Its Applications. Their goal is to “...create learning environments where mathematics is used to investigate and model real issues in our world” (COMAP, 2012).

Hands-on activity is another innovative technique that can be used to get students more involved in a lesson. Some students do not respond well to lecturing, while other students dislike interacting with their peers. The point is that students have many different methods of learning. Hands-on learning reaches a different cadre of students. Furthermore, hands-on activities force students to move around the classroom while interacting, discussing, and reasoning with each other. This is a great alternative to teacher-led lectures. As long as the learning environment is maintained, it can be advantageous to give students a time when they are in control.

Mathematics lessons can be created to reach this goal by crafting group activities. Props or devices are great ways to get students involved, which results in maintaining their attention throughout the entire lesson. In this project, one module takes full advantage of this approach. The trigonometric function module utilizes a device which draws the graph of the sine and cosine functions. For another lesson, one may create an activity that involves a student standing on a piece of plywood, while students shake it. If the intensity of the shaking increases exponentially, students will see the significant difference between two and a three on the Richter scale. This activity helps those students who struggled to understand the significance of exponential growth when only looking at the mathematics.

The final theme used to gain student interest is entertainment. There are students that are not motivated by engineering and science applications. These students’ interest may be captured by curiosity or a human’s natural desire for knowledge. Entertainment can take several forms such as stories, humor, and playfulness. A good way of choosing a topic for entertainment is by exploring current fads, TV shows, music, games, and popular interests. The lesson must be built around the typical

student lifestyle, which in turn connects to mathematics. The key to these lessons is to have fun. Ideally, students will perform mathematical processes while smiling and having fun.

For instance, a student's popularity is constantly evaluated in high school. Therefore, a lesson on logarithms has been created for this project which has students calculating popularity. The story is designed to embrace the culture of a typical high school. Another lesson created for this project involves a starving man on an island who orders a pizza from a cell phone he found. This is a great example of having fun while still teaching series and sequences (both topics that students may find peripheral to their lives). Many of the topics discussed by Lakatos are beyond high school math but he makes it sound fun as well.

The next factor in a successful math lesson is discovery. In their report to the president, the PCAST outlined some overarching recommendations. The second of these five recommendations is to advocate and support a push for discovery-based courses (Holdren & Lander, February, 2012). PCAST recognizes that it is important to not always give the formulas and processes for solving math problems. When students are given formulas, they are quick to use them without knowing their origin. This holds for science and mathematics. Imagine a student using the quadratic formula when he/she does not know what a , b , or c represent. Better yet, imagine a student being told that the discriminant gives insight into the number of real roots in a quadratic function, without him/her picturing what it means for a function to have only imaginary roots. If you give students formulas and rules without explanations, they tend to have a greater argument for not knowing the relevance of the topic. The modules in this project force students to discover meanings on their own. This way the students do not need to memorize a formula. When a student has proven the ability to derive a formula, its definition becomes trivial.

It is also important to note that discovery has no boundaries. As long as students are curious, there is no end to what they can learn. This is why it is important for the modules in this project to leave open-ended questions. Questions that have more than one answer allow students to be creative. Creativity is hard to come by in high school mathematics. There are lessons in these modules that have multiple answers, allowing students to discuss and defend their answer with their peers.

This is a great transition into discussing what could be the most important ingredient for success for a math student: confidence. In order to succeed in mathematics, students need to have confidence in their process and answer. A student who does not have the confidence to try and give an answer will continuously struggle. This directly follows from the fact that learning stems from the process, not the solution. Therefore, it is important to create lessons that boost the confidence of students while challenging them. The statistics in Jump Math program, discussed earlier, speak highly of the importance of building a student's confidence.

The logarithms module created for this project is a great example of building a student's confidence. The module starts with examples and exercises that use exponents, which students have already learned. The lesson continues by slowly introducing the logarithm as another way of expressing exponents. This way, students see logarithms as an extension of a known concept, instead of a new, intimidating function.

Possibly the most imperative part of making a lesson college preparatory is a focus on retention for future courses and evaluations. A student properly prepared for college level mathematics is prepared to start his first year in a Calculus I course, or above. Thus, students need to retain their skills for more time than just a testing period. Professor John Goulet at WPI contends that, at the end of each lesson, a student should be able to tell you the main topic. If students cannot name the topic of a day's lesson, then they did not fully grasp the concept. The teaching modules in this project accomplish this

goal by creating activities and stories that are relatable to both the students *and* the subject. It is important that both of these criteria are met. If the lesson is only relatable to the students and not the subject, the students will struggle to recall the mathematical topic of the lesson. If the lesson fails to be relatable to the students but relates perfectly to the subject, it is a poorly chosen application because students lose interest.

The standards-based testing of education in United States is another reason why retention of the overall concept is important. Especially in Massachusetts, standards-based testing is becoming more and more apparent in education. Educators want to verify that their students are completing high school with a standard set of skills in math, science, history, and English. The concepts covered in the tenth grade mathematics section of the Massachusetts Comprehensive Assessment System (MCAS) do not go beyond those taught in Algebra II (Massachusetts Department of Elementary & Secondary Education, 2011). More specifically, the Massachusetts Curriculum Framework for Mathematics ensures that students have a solid foundation in the following areas: Number and Quantity, Algebra, Functions, Modeling, Geometry, and Statistics and Probability (Massachusetts Department of Elementary & Secondary Education, 2011). Going further, although Precalculus is not included in the Massachusetts Curriculum Framework for Mathematics, it is crucial in order to be properly prepared for college level mathematics.

Almost seventy percent of high school graduates in the year 2010 continued their studies in pursuit of more advanced degrees (United States Department of Labor, 2011). Meanwhile, the completion of an associate's or bachelor's degree likely requires at least one mathematics course. The lessons created for this project are intended to prepare students like these for mathematics at the college level. Courses that mathematically-focused students should expect to see in college include, but are not limited to, Calculus I-III, Differential Equations, Linear Algebra, Discrete Mathematics, and

Advanced Calculus. Introducing asymptotes, limits, and applications of sequences and series give a student an upper hand going into these college courses.

The goals of this project are clear and concise. Lessons are created with the use of stories, applications, challenge problems, college level concepts and the Massachusetts Curriculum Framework. The use of these lessons in the classroom will pique student interest while challenging them intellectually. In turn, students will be more confident in the field of mathematics and their success in higher level mathematics will be more attainable.

Modules

Imaginary Numbers

The following module introduces complex numbers and the complex plane. By the end of this lesson, students will have the ability to algebraically manipulate complex numbers and fully understand the graphical representation of a complex number. This goal will be accomplished through an unconventional story that grasps students' imagination. More importantly, it will utilize the skills they already have without making the concept too complicated.

The imaginary unit is something that can only be introduced by its definition: the square root of negative one. A standard lesson in a Precalculus textbook continues the lesson by defining a complex number and introducing operations with complex numbers (Larson, 2012). Operations of addition and subtraction are given by formulas which are defined by the sum and the difference. Furthermore, Larson discusses the associative, commutative, and distributive properties which apply to the arithmetic of complex numbers. Final lesson notes include the conjugate and conversion to standard form of a complex number. The grand finale to any complex number lesson is the return of the quadratic formula. At this point in the lesson, students finally have the ability to find all possible zeros, imaginary or real, when solving a quadratic equation. Later in the chapter, students graph quadratic functions using graphing calculators. This helps reveal the meaning of an imaginary root. Repetition is a key tool used by standard textbooks to reinforce the concept of complex numbers.

Although repetition has a history of success, high school students want to have fun! This is why the imaginary number is introduced as a student's imaginary friend in the following original lesson. Mathematically, the definition is the same. Yet the story in this lesson allows students to picture the mysterious square root of a negative number as something more. Although it requires a little imagination, the interaction between imaginary and real numbers takes a logical turn that directly relates to the mathematics. After a fun story about imaginary friends, the lesson transitions students back into the mathematics of complex numbers.

The best part of this module is the reintroduction of basic algebra. As students in Precalculus, manipulating first degree polynomials should be in their basic skill set. For this reason, students are not given formulas or properties of complex numbers. The lesson merely asks students to treat the imaginary number as a variable. The only algebraic difference is that when you square this imaginary number, you get negative one. This is better for students because explaining the existence of the square root of negative one can be difficult on its own. There is no need to confuse the process more by teaching formulas and properties that are already engraved in their brains.

In this lesson, the final step in the introduction of complex numbers is the analysis of the discriminant. A quick study of Figure 3 describes the interaction between imaginary numbers and the zero(s) of a quadratic function. An exercise graphing complex numbers in the complex plane also helps reinforce this imaginary concept.

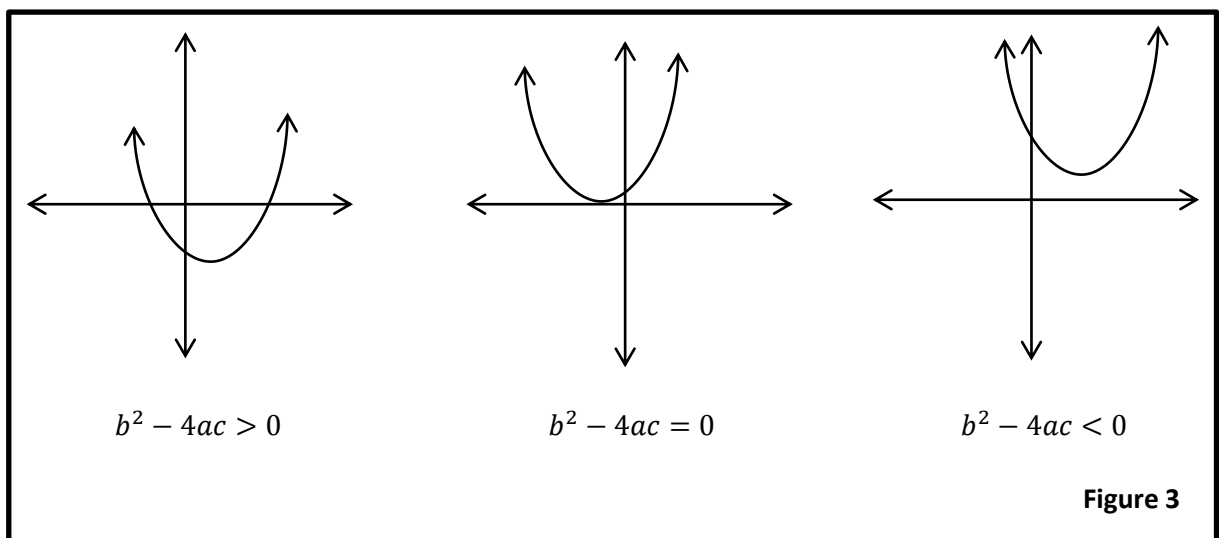

The application of complex numbers extends well beyond zero(s) of a quadratic function. This concept is an important basis for polar coordinates, which apply to both physics and mathematics. A great way to introduce polar coordinates is directly following a lesson such as this module on complex numbers. Polar coordinates can be taught as a second way of expressing complex numbers. Instead of

representing the complex number in terms of two axes, students apply their knowledge of triangles. There are logical steps that students can take to understand the relationship between the two.

Once students grasp the concept of complex numbers in polar form, their preparation for college has improved. Calculus, Linear Algebra, and Physics courses all take full advantage of the polar coordinate system. In Calculus, polar coordinates are far more efficient than rectangular coordinates when finding the area of certain regions, such as cardioids (Edwards & Penney, 2008). Regions that require polar coordinates are normally not bounded by the x-axis. These areas are centered or expanded from the origin. Of course, students must be comfortable with their trigonometric functions in order to find this approach advantageous.

The complex number system is seen in courses ranging from Linear Algebra to modern algebra (such as WPI's Rings and Fields). Whether computational or abstract, the imaginary number is everywhere in mathematics. Like any other topic, more exposure allows for more understanding. Without complex numbers, students miss out on an entire set of tools that are employed throughout their college career.

Intro to Imaginary Numbers

Mathematical Utopia

There exists a mathematical utopia where all unanswered questions have a solution. Here, the following things exist: the last digit of pi; a number greater than infinity; $5 \bullet 4=7$; and the square root of a negative number. Imagine we took one of these things back to our Real (\Re) world of math. For this exercise, we'll pretend that the square root of a negative number exists. Since the existence comes from our imaginary world, it's fitting to use the letter i .

Q. What do all square roots of negative numbers have in common? (Recall: $\sqrt{ab} = \sqrt{a} \bullet \sqrt{b}$)

$$\sqrt{-7} = \sqrt{-1} \bullet \sqrt{7}$$

$$\sqrt{-3} = \sqrt{-1} \bullet \sqrt{3}$$

A. We can deal with the square root of a negative number when we factor out $\sqrt{-1}$.

Let us define $i = \sqrt{-1}$. Since we have defined our number "i" as imaginary, we have made it clear that it is not Real (\Re). As long as we know that, we need to figure out what happens when we use i with Real numbers (\Re). How can we make more sense of this?

What is $5+i$? ... $5 \bullet i$?

What is $i+i$? ... $i \bullet i$?

What is i^2 ? ... i^3 ? ... i^4 ?

We have two questions: 1. How does i interact with itself?
 2. How does i interact with Real numbers (\Re)?

Imaginary Friend

Think of i as your imaginary friend that you had when you were a little kid. Imagine that one day you bring him to school with you to find out how he will interact with your friends. Since imaginary friends are so popular among your friends, you also want to find out how he will interact with your friends' imaginary friends. There are two types of interaction between people: verbal communication and physical contact. When one of these interactions is successful, the two successfully develop a friendship.

We will denote verbal communication as addition and physical contact as multiplication. There are six possible combinations of interactions in this exercise, which we will represent in the following table:

Interaction	Example	Type of Interaction	Friendship	Result	
Addition of real and imaginary	$2+i$	Verbal Communication	No	Neither	No simplification
Addition of real and real	$1+5$	Verbal Communication	Yes	Real	6
Addition of imaginary and imaginary	$3i+4i$	Verbal Communication	Yes	Imaginary	$7i$
Multiplication of real and imaginary	$5 \bullet 7i$	Physical Contact	No	Imaginary	$35i$
Multiplication of real and real	$6 \bullet 3$	Physical Contact	Yes	Real	18
Multiplication of imaginary and imaginary	$2i \bullet 4i$	Physical Contact	Yes	Real	-8

While this table answers most of the questions about the interaction between real and imaginary people, it also raises more questions.

Q. Why does physical contact between two imaginary people make one real person?

A. Recall the definition of an imaginary person: $i = \sqrt{-1}$. So when we multiply $i \bullet i$, we are multiplying $\sqrt{-1} \bullet \sqrt{-1}$, which is clearly equal to -1. Our conclusion is that $i^2 = -1$

Q. What is the result of verbal communication between a real person and an imaginary person yield if it's neither real nor imaginary?

A. This is called a complex number. A complex number has two parts: imaginary and real. Complex numbers are found in the form $a+bi$.

Q. Are you telling me that we can solve all results of the quadratic formula, now?!

A. YES!

Exercises Using Complex Numbers

(Hint: Treat i like any other variable)

1. $(3+4i) + (2-3i)$

2. $(1-2i) - (10+i)$

3. $(6+4i) \bullet (4-5i)$

4. $(1+3i) \bullet (1-3i)$

5. $2 \bullet (3+5i)$

6. $4i^{213} \bullet (1+2i)$

Graph the Interaction

Can you predict in what quadrant each interaction can exist?

- Real people only exist on the real line.
- Imaginary people only exist on the imaginary line.
- Complex Numbers live everywhere else.

7-12. Graph your answers to problems 1-6.

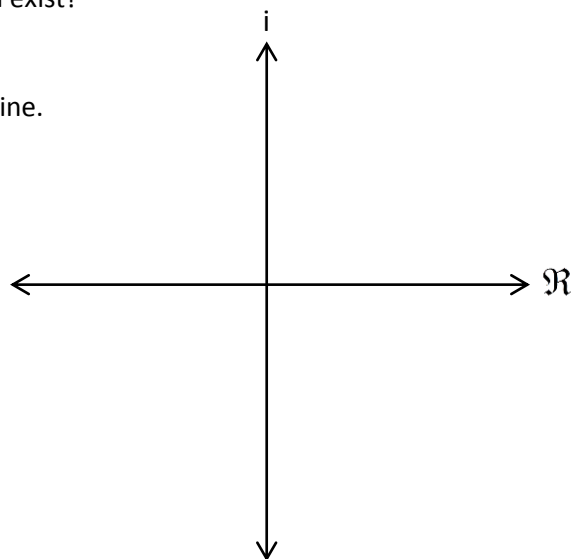

Return of the Quadratic Formula

So what is this business about solving all forms of the quadratic formula? Recall when we used the quadratic formula to solve quadratic equations. If our text or teacher was kind to us, we always seemed to get a positive number for the discriminant underneath the radical. Now we can understand all possible answers to the quadratic formula!

Quadratic Formula: For $ax^2 + bx + c = 0$, we know $x = \frac{-b \pm \sqrt{b^2 - 4ac}}{2a}$

Recall the geometric representation of the discriminant values.

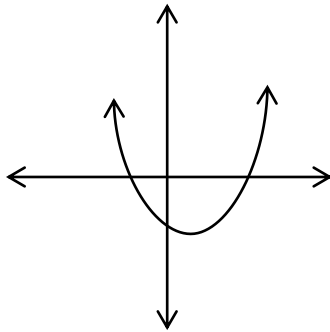

$$b^2 - 4ac > 0$$

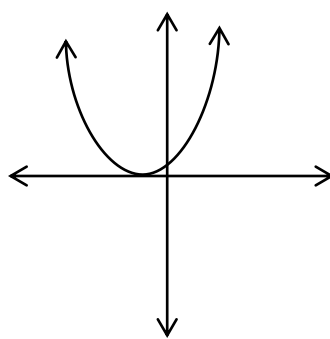

$$b^2 - 4ac = 0$$

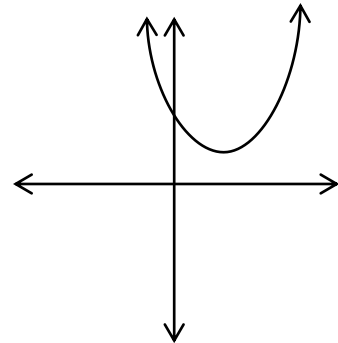

$$b^2 - 4ac < 0$$

Exercises: Find the real and/or imaginary roots using the Quadratic Formula (Solve $f(x)=0$)

1. $f(x) = x^2 + 2x + 1$
2. $f(x) = x^2 + 6x + 10$
3. $f(x) = \frac{25}{8}x^2 - 3x + 2$
4. $f(x) = 9x^2 + 1$
5. $f(x) = 3x^2 - 5x + 2$
6. $f(x) = \frac{1}{4}x^2 + \frac{3}{2}x + \frac{153}{4}$

Logarithms

A frequently underrated topic in mathematics is logarithms. This lesson is designed to reinforce the relevance of logarithms and shift away from using the “log” button on a calculator. In order to achieve this goal, students will first review exponents. The lesson builds up to an understanding of the relationship between logarithms and exponents. The final objective is for students to have mastered logarithms and understand a real life application.

Logarithms are typically introduced to high school students in Precalculus as the inverse of the exponential function (Larson, 2012). In Larson’s text, *Precalculus with Limits: A Graphing Approach*, students are asked to evaluate logarithms to different bases. After this quick introduction, students are taught how to evaluate logarithms using a calculator or by using given properties of logarithms. These properties simplify problems by eliminating the need to evaluate the logarithm. Each of the four given properties makes evaluating logarithms by calculator unnecessary.

Larson also helps students understand the graph of logarithmic functions. Since the logarithm is the inverse of the exponent, students are taught to graph the exponential function, which they have practiced before, and reflect the image about the $y=x$ diagonal. The other tool used to graph logarithms is the parent function. Following the graphical model of the logarithmic function, students learn how to evaluate the natural logarithm, using a calculator, while being taught more properties and change of base mechanics. Applications used in the text include given logarithmic functions that apply to cooking, intensity of sound, investment, ventilation, real estate, and space. Of course, the most emphasized application of logarithms is solving exponential equations.

The logarithm module in this project uses a story about popularity: one of the most important things to some high school teenagers. The story is first introduced as an exponential growth problem where a student is trying to maximize his popularity points. The students are then given different

information to solve the same popularity problem. The lesson introduces logarithms as a better method of denoting the same information. In other words, problems involving logarithms can be viewed as the same as those involving exponents but with different unknowns.

The best feature of this lesson comes from students creating their own logarithmic problem. In order to be successful in such an exercise, students need to thoroughly grasp the entire concept. This also adds an element of entertainment as students work through each other's problems. The last few exercises utilize a familiar application of logarithms: the Richter scale. With a thorough understanding of logarithms and basic algebra, students are able to work through these problems with very few issues. Although a calculator is needed for precise answers, students are encouraged to estimate the answer using what they have learned in the lesson. Estimation is a great way to prove understanding and to make sense of what the calculator outputs. A teacher can keep the student's attention by using examples of current and/or well-publicized earthquakes.

Anywhere there are functions to solve, there are logarithms. Logarithms are seen in Calculus, Differential Equations, Linear Programming, Statistics, and Discrete Mathematics, to name a few. Yet, logarithms are something that college professors expect students to understand when they arrive to class on Day One. A proper background in logarithms is one where students are able to: recognize when logarithms are necessary; picture exponential growth; and estimate a function's value. Exercises in Differential Equations constantly use the exponential function (Davis, 2009). When solving a differential equation that has an unknown in the exponent, the logarithmic function is a necessity to finding a solution. In courses that require proofs such as Combinatorics and Advanced Calculus, students are oftentimes asked to show that a function is positive or negative. Such problems are given with the known fact that the natural logarithm is negative at values between zero and one. Furthermore, students should know where a logarithm does and does not exist. One can see that when logarithms are

applied to college level mathematics, students need to know more about logarithms than the location of the “log” button on a calculator. This module aims to fill that gap.

Introduction to Logarithms

Exponents

Edwin just started his freshman year in high school. He is a smart kid but not the most popular. Since good grades come easy for Edwin, he decided that this year he is going to focus on his popularity. His goal is to maximize his popularity before sophomore year. Of course, the real reason he wants to be more well-known is because there is a really cute girl, Lauren, but she is a senior.

The more people that Edwin gets to know, the more popular he'll be. Furthermore, he is more likely to be noticed by Lauren if he knows more people her age. For this reason, he came up with a model where his popularity is judged by his number of popularity points. The more points he gets, the more popular he is and specifically:

First friend he gains in each class is worth the following points

Senior: 10 points

Junior: 8 points

Sophomore: 4 points

Freshmen: 2 points

For every friend he gains after the first in each class, the points per new friend increase as follows

Senior: x10 points

Junior: x8 points

Sophomore: x4 points

Freshmen: x2 points

Example

Q. Edwin befriends 2 seniors, 2 juniors, 5 sophomores, and 6 freshmen. How many popularity points does he have?

A. seniors: $10^2=100$; juniors: $8^2=64$; sophomores: $4^5=1024$; freshmen: $2^6=64$

$$\begin{aligned}\text{Points} &= 10^2 + 8^2 + 4^5 + 2^6 \\ &= 100 + 64 + 1024 + 64 \\ &= 1,252 \text{ popularity points}\end{aligned}$$

Exercises

1. Edwin befriends 1 senior, 3 juniors, 4 sophomores, and 8 freshmen. How many popularity points does he have?
2. Edwin befriends 4 seniors, 1 sophomore, and 5 freshmen. How many popularity points does he have?
3. Edwin befriends 10 seniors. How many popularity points does he have?
4. Edwin befriends 10 juniors. How many popularity points does he have?
5. Edwin befriends 10 freshmen. How many popularity points does he have?
6. Which class grows faster? Explain the significance.

Exponents → Logarithms

While Edwin was doing his calculations, he also noticed that it makes much more sense to just spend his time befriending seniors (so he joined the chess team, but got tired of that very quickly). He realized his model was accurate in modeling that seniors will help his popularity more than freshmen, especially if he wants Lauren to notice him. Now he is just wondering how many seniors he needs to befriend to reach enough popularity points for of Lauren's attention.

Edwin needs a new way of modeling this problem.

Example

Q. Edwin thinks that 100,000,000,000 (that's 100 billion, BTW!) popularity points will be enough to win over Lauren. How many seniors does he need to befriend?

A. $10^n = 100,000,000,000$ where n is the number of seniors Edwin needs to befriend. As you can see, the model is the same but now we have different information.

Let's see... $10^9 = 1,000,000,000$

$10^{10} = 10,000,000,000$

$10^{11} = 100,000,000,000$

Thus, $n = 11$

Edwin needs to befriend 11 seniors in order to reach 100,000,000,000 popularity points.

Exercises

7. Edwin's goal is to get 100,000 popularity points. How many seniors does he need to befriend?
8. Edwin's goal is to get 1,000,000 popularity points. How many seniors does he need to befriend?
9. Edwin's goal is to get 10,000,000 popularity points. How many seniors does he need to befriend?
10. Edwin's goal is to get 10^{20} popularity points. How many seniors does he need to befriend?
11. Explain your method in solving these problems.

Discussion

There is a way to express this process. The key tool is logarithms.

Example

Q. Edwin's goal is to get 1,000,000 popularity points. How many seniors does he need to befriend?

A. Instead of solving $10^n = 1,000,000$

We say $\log_{10} 1,000,000 = n$ "Log of 1,000,000 base 10 is equal to n "

Now we are solving for n

Exercises

12-16. Express problems 1-5 in terms of logarithms.

Logarithms to Different Bases

There were 4 seniors in Edwin's Algebra II class and they needed to get a good grade in the class in order not only to graduate but also keep their GPAs looking good. Edwin took this opportunity to help them with their homework thinking that the 5 of them could become his (valuable) friends. It worked and, next thing you know, he had 4 senior friends! After they aced Test 1 in the class, Edwin knew he had Lauren's attention. He approached her and she actually called him weird and told him to go away. With his enthusiasm towards Lauren a bit deflated at this point, he decided to reconsider his approach.

Example

Q. Edwin wants to get to know some people in his freshman class. He is looking to get 128 popularity points. How many freshmen does he need to befriend to accomplish this goal? (Recall the point system from the first problem)

A. $\log_2 128=n$

How do we use base 2? Recall the definition:

$\log_2 128=n$ is equivalent to saying $2^n=128$

Let's see... $n=5: 2^5=32$

$n=6: 2^6=64$

$n=7: 2^7=128$

So, $\log_2 128=7$

Edwin needs to befriend 7 freshmen in order to earn his goal of 128 popularity points.

Exercises

17. How many freshmen does Edwin need to befriend to earn 16 popularity points?
18. How many freshmen does Edwin need to befriend to earn 256 popularity points?
19. How many juniors does Edwin need to befriend to earn 512 popularity points?
20. With friends from multiple classes, what are 2 different options that Edwin has to reach 1,320 popularity points?
21. What are 2 different options that Edwin has to reach 2,000 popularity points?

Challenge

Add a stipulation to Edwin's model such as:

Edwin's brother is a junior and his presence takes points away from Edwin's popularity points.

Edwin gets in a fight with Isaac and loses all the friend that Isaac is friends with

...be creative!

What would this model look like? Can you come up with an example that uses your model?

Application of Logarithms in the Richter scale

Date	Location	Magnitude
4/24/2012	Carlsberg Ridge	5.3
4/24/2012	Peru	4.2
4/24/2012	Japan	3.5
4/23/2012	Tonga Islands Region	4.6
4/23/2012	Kuril Islands	4.4

Above are the recorded earthquakes in the past two days in just North America.

The Magnitude of an earthquake is calculated on a scale called the Richter scale, which is calculated using the following equation:

$M = \log_{10} (I/S)$, where I = Intensity of an earthquake determined by the amplitude of a seismograph in centimeters and S = Intensity of a standard earthquake, which is 1 micron = .0001 cm

Amplitude of a standard earthquake is

$$M = \log_{10} (S/S) = \log_{10} (1) = 0$$

So, for example, an earthquake of magnitude 2.0 is 100 times stronger than (moves a seismograph 100 times as much as) a standard earthquake.

Recall:

$$\log_{10} 1 = \log_{10} 1, \text{ which means } 10^x = 1 \rightarrow 10^0 = 1, \text{ so } x=0$$

Example

Q. How many times stronger (amplitude) was the earthquake in Tonga Islands than in Kuril Islands?

A. Let N = Amplitude of Tonga Islands Earthquake and V = Amplitude of Kuril Islands Earthquake

$$4.6 = \log_{10} (N/S)$$

$$4.4 = \log_{10} (V/S)$$

$$4.6 = \log_{10} N - \log S$$

$$4.4 = \log_{10} V - \log S$$

$$4.6 = \log_{10} N - (-4)$$

$$4.4 = \log_{10} V - (-4)$$

$$\log_{10} N = 0.6$$

$$\log_{10} V = 0.4$$

$$N = 10^{0.6}$$

$$V = 10^{0.4}$$

$$N \approx 3.98$$

$$V \approx 2.51$$

$N/V \approx 1.59$ and therefore, Tonga Earthquake was approximately 1.6 times stronger than Kuril Earthquake.

Discussion

$$\log (A/B) = \log A - \log B$$

$$\log (A*B) = \log A + \log B$$

Do these properties make sense? Why? Show Examples (test it out).

Why did we get a negative number for the answer to a logarithm?

Does that make sense?

When do you get positive/negative answers to a logarithmic problem?

Wow, the Richter scale is kind of deceiving...EXPONENTIAL GROWTH!

Exercises

1. What did the seismograph read on April 24, 2011 in Peru? Japan?
2. How many times stronger was the earthquake in Carlsberg Ridge than in Peru?
3. How many times stronger was the earthquake in the Kuril Islands than in Japan?
4. Suppose that in November, the Tonga Islands Region is expecting an earthquake 100 times stronger than the earthquake in April. What will this earthquake read on the Richter scale?

Series

The series module is primarily designed to help students master the basic concept of infinite and finite geometric series. Students will discuss the concept of convergence and divergence of a series. The study of series also opens the door to new notation such as the summation symbol. Other topics that can be discussed in a series lesson are limits and asymptotes, which become easier when given a graph to visualize the data.

Traditionally, series are introduced in a high school Precalculus course. Leading up to the lesson on series, students are first taught infinite/finite sequences, factorial and summation notation, properties of sums, which is followed by the introduction to series (Larson, 2012). In Larson's Precalculus text, the series is briefly introduced. Students are given graphing examples for their graphing calculators, as well as an application of series: population growth. Later sections introduce geometric sequences and series simultaneously, which ends the discussion on series. Exercises throughout these sections ask students to represent sums in sigma notation; calculate partial sums; find the sum of a given series, if possible; and solve annuity and interest applications. Calculators are not discouraged when computing the sum of a series.

This lesson takes a new twist on geometric series. Instead of giving students several examples to work through, students are given one story. As the story develops, so does their understanding of series. The long story of a man starving on an island lets students use their imagination and have fun with the mathematics. Before formally introducing series, students graph the pattern, which allows them to visualize a trend in the data. Students are also encouraged to interpret the graph for themselves. There are at least two graphical representations that students may use. Both answers give a different series but the result has the same interpretation. After modeling the starving man's data, a teacher-led discussion leads to the introduction of new notation and vocabulary. This is a great opportunity to

engage students in a discussion about asymptotes and limits. This is done by simply asking, “Will the starving man ever run out of food?”

A key part of the series module is discovery. The only time students are given a series is when they are asked to derive the formula for the limit of a converging geometric series. Otherwise, students are expected to make a table and understand the data before deriving a series. Not limiting a problem to one answer is another way that this module encourages discovery. Furthermore, after successful discovery, students are more confident in future math problems.

Problems that students may see in the future involving series are seen in several college level courses such as Calculus, Differential Equations, Discrete Mathematics, and Advanced Calculus. There is a great introduction and conceptual understanding of series in Discrete Mathematics (Rosen, 2007). In this section, series are introduced as if students have never seen the topic before. Students are given several summation formulas without explanation. With the proper background, students should be able to interpret the meaning of the formulas and develop the ability to recognize patterns. Rosen also introduces the harmonic series and uses a proof by induction for interpretation purposes. In lessons such as Rosen’s, it is important that students understand both the concept and the arithmetic.

A great example of the need for a conceptual understanding of series appears in Advanced Calculus. Advanced Calculus takes an in-depth look at the limit and uses series in order to accomplish the goal (Rudin, 1976). The Comparison Test compares a given series to a geometric series of greater value. If the geometric series converges, then the series of lesser value converges as well. It is important that students have been thoroughly exposed to geometric series at this point in their mathematics careers. Other topics involving series in Advanced Calculus are the Root and Ratio Tests. A graphical interpretation of these tests help students better understand the meaning. If a student was to graph the

root of a series, the test's results of convergence and divergence come with ease. Similarly, the ratio test is validated by a graphical representation.

Overall, the limit is the most important and most widely used concept in Advanced Calculus and several college level mathematics courses. It is important that students are introduced to the limit as early as its role becomes dominant in the mathematical discourse. It is most advantageous for students to see the limit applied to several examples in order for them to understand its significance and not be intimidated by its meaning. After quadratic functions, series are one of the earliest applications of limits in high school mathematics courses.

Pizza and Geometric Series

There is a starving man on an island. One day he's walking around and finds a cell phone. He tries to call 911 and it doesn't work. Since he doesn't know any of his friend's or family's numbers, he looks in the contacts of the phone and finds, "Fast Way Pizza." He hits send and the phone starts ringing. He's so excited that when the person answers he says, "Get me the largest pizza you can make!" He hangs up the phone.

One hour later, a plane is flying by, so he waves and waves but the pilot doesn't appear to see him. He then realizes that something is falling from the plane towards the other end of the island. He runs as fast as he can until finally he sees it in the distance: a 35" pizza. Overwhelmed and overexcited, he opens it and begins eating. It's been days since he has had anything to eat!

Ten minutes later, he stops because he is full. He looks down and only half of the pizza is remaining. He sees a note inside the box that reads, "The first one is on us." He closes the pizza box and falls asleep, using the pizza box as a pillow. 12 hours later, the not-so-starving man wakes up and is hungry again. This time, he only eats two pieces. He figured this would be a great way to start a day of hunting and searching for more things to eat. This way, hopefully he would have something else to eat by the time he finished the pizza. That night, he falls asleep after a long, unsuccessful day of hunting.

The following morning, he wakes up and has a slice of pizza. It is at this point that he realizes he is going through this pizza fast! He has already eaten $4+2+1=7$ slices and has but one left! He thinks to himself, "At this rate, how long is this pizza going to last?"

Here is a table to help us model this problem:

	Day 1	Day 2	Day 3
Model 1	$\frac{1}{2}$ Pizza	$\frac{1}{4}$ Pizza	$\frac{1}{8}$ Pizza
Model 2	4 Slices	2 Slices	1 Slice

So each day he is eating half as much as he did the day before. Notice there are two ways of modeling this problem. Both are correct. Is there another way we could model this problem?

Discussion

Both models assume that the pizza is cut into 8 slices. When you examine the problem (specifically day 2 and 3), you'll see that the only way this problem will work with geometric series will be for a pizza that is cut into 8 slices. It is possible to model a different problem with different parameters. Good to discuss that sometimes you need to make assumptions in problems. But it is good to question everything; that's what mathematicians do!

Here, we say he eats half of what is left each day. Continue the pattern in order to complete the table:

	Day 1	Day 2	Day 3	Day 4	Day 5	Day 6
Model 1	$\frac{1}{2}$ Pizza	$\frac{1}{4}$ Pizza	$\frac{1}{8}$ Pizza			
Model 2	4 Slices	2 Slices	1 Slice			

What if we wanted to graph the data?

Discussion

This question has two possible interpretations. Luckily, both will lead to the idea of the limit.

Option 1: We could graph the table above and as they continue the graph, they will see that with each day, the amount he eats get closer and closer to zero but never reaches zero. Therefore, he will never run out of pizza.

Option 2: We could create a new table that shows Days vs. Total Pizza Eaten. This will allow the students to see the limit approach 1 Pizza or 8 Slices. This is also a great way to introduce geometric series.

Option 1

Model 1

Table:

Day	x	1	2	3	4	5	6	7	8
Fraction of Pizza Eaten /Day	y	$\frac{1}{2}$	$\frac{1}{4}$	$\frac{1}{8}$	$\frac{1}{16}$	$\frac{1}{32}$	$\frac{1}{64}$	$\frac{1}{128}$	$\frac{1}{256}$

Graph:

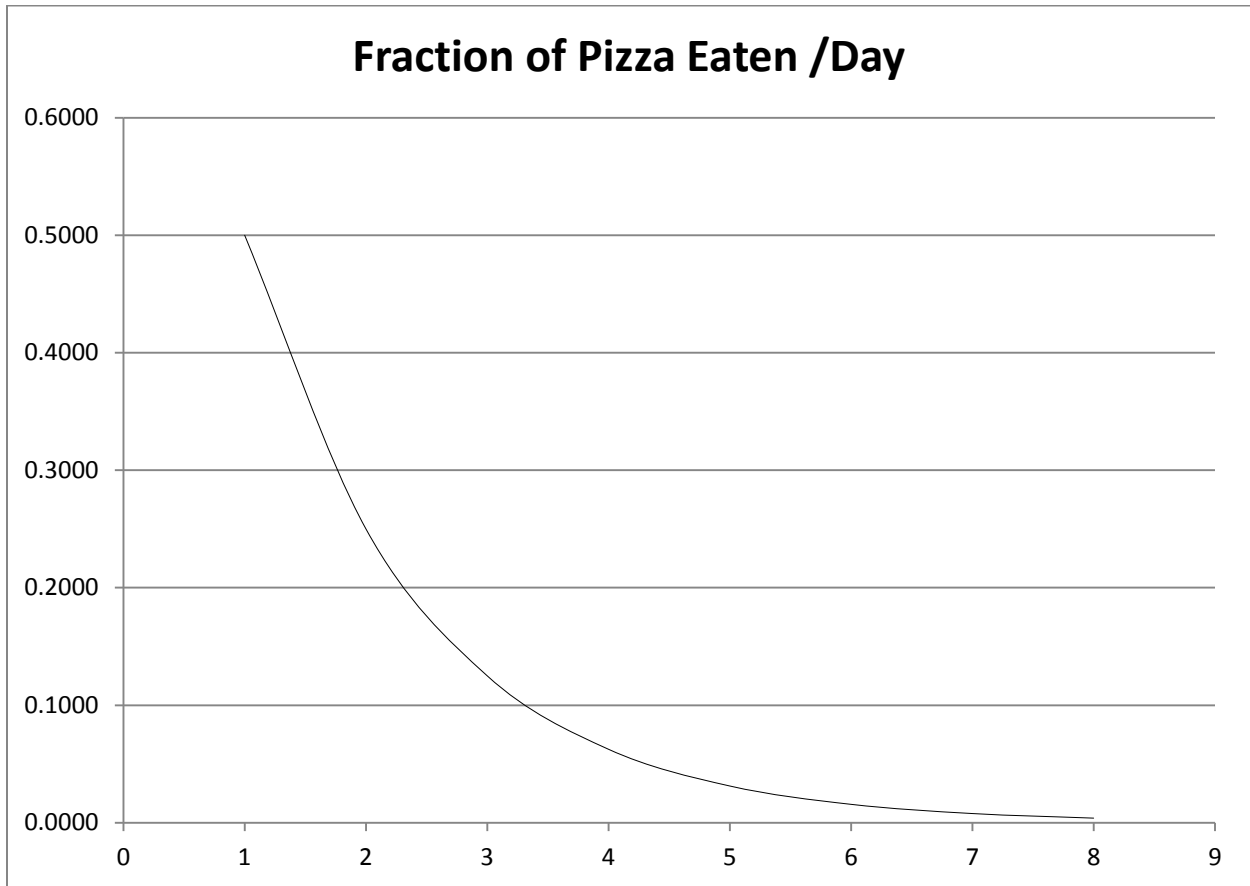

Model 2

Table:

Day	x	1	2	3	4	5	6	7	8
Slices of Pizza Eaten /Day	y	4	2	1	$\frac{1}{2}$	$\frac{1}{4}$	$\frac{1}{8}$	$\frac{1}{16}$	$\frac{1}{32}$

Graph:

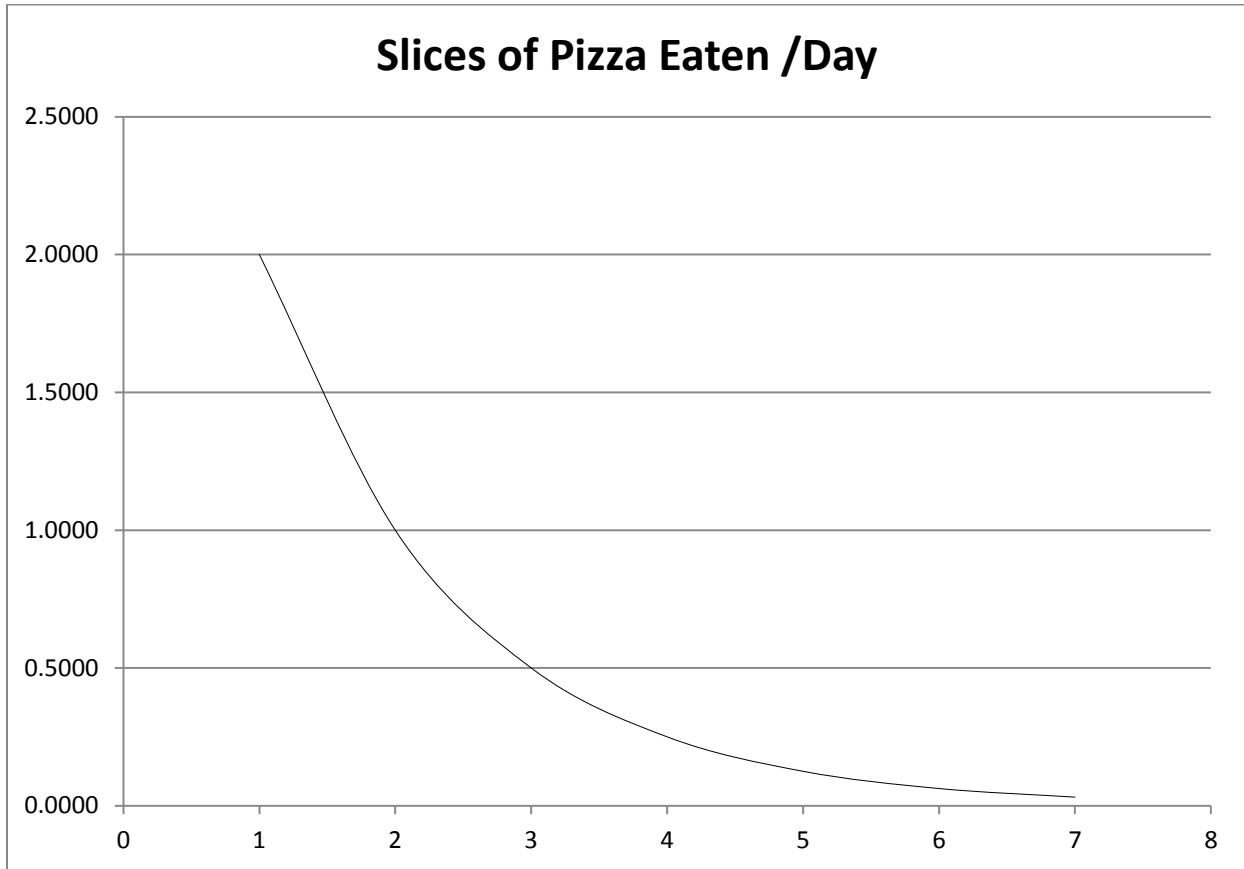

Option 2

Another way to model this data is to calculate the total amount of pizza or slices of pizza he has eaten up to and including Day n .

Model 1

$$\text{Day 1: } \frac{1}{2} = \frac{1}{2}$$

$$\text{Day 2: } \frac{1}{2} + \frac{1}{4} = \frac{3}{4}$$

$$\text{Day 3: } \frac{1}{2} + \frac{1}{4} + \frac{1}{8} = \frac{7}{8}$$

$$\text{Day 4: } \frac{1}{2} + \frac{1}{4} + \frac{1}{8} + \frac{1}{16} = \frac{15}{16}$$

Will it ever reach 1 total pizza? $\frac{1}{2} + \frac{1}{4} + \frac{1}{8} + \frac{1}{16} + \frac{1}{32} + \frac{1}{64} + \frac{1}{128} + \frac{1}{256} \dots = 1$?

Can you find a pattern?

$$\frac{1}{2^1} + \frac{1}{2^2} + \frac{1}{2^3} + \frac{1}{2^4} + \frac{1}{2^5} + \frac{1}{2^6} + \frac{1}{2^7} + \frac{1}{2^8} \dots$$

We can express the total amount of pizza eaten total in terms of Day n . In order to do this, we need to introduce the summation symbol: \sum

$$\text{For example: } \sum_{n=1}^6 \frac{1}{n} = \frac{1}{1} + \frac{1}{2} + \frac{1}{3} + \frac{1}{4} + \frac{1}{5} + \frac{1}{6}$$

$$\text{For our problem using Model 1, we get } \sum_{n=1}^{\infty} \frac{1}{2^n}$$

Model 2

$$\text{Day 1: } 4 = 4$$

$$\text{Day 2: } 4 + 2 = 6$$

$$\text{Day 3: } 4 + 2 + 1 = 7$$

$$\text{Day 4: } 4 + 2 + 1 + \frac{1}{2} = \frac{15}{2}$$

Will it ever reach 8 total slices of pizza? $4 + 2 + 1 + \frac{1}{2} + \frac{1}{4} + \frac{1}{8} + \frac{1}{16} + \frac{1}{32} \dots = 8$?

Can you find a pattern?

$$\frac{8}{2^1} + \frac{8}{2^2} + \frac{8}{2^3} + \frac{8}{2^4} + \frac{8}{2^5} + \frac{8}{2^6} + \frac{8}{2^7} + \frac{8}{2^8} \dots$$

$$\text{For Model 2, we get } \sum_{n=1}^{\infty} \frac{8}{2^n}$$

Model 1

$$\sum_{n=1}^{\infty} \frac{1}{2^n}$$

Table:

Day	x	1	2	3	4	5	6	7	8
Total Fraction of Pizza Eaten	y	$\frac{1}{2}$	$\frac{3}{4}$	$\frac{7}{8}$	$\frac{15}{16}$	$\frac{31}{32}$	$\frac{63}{64}$	$\frac{127}{128}$	$\frac{255}{256}$

Graph:



Model 2

$$\sum_{n=1}^{\infty} \frac{8}{2^n}$$

Table:

Day	x	1	2	3	4	5	6	7	8
Total Slices of Pizza Eaten	y	4	6	7	$15/2$	$31/4$	$63/8$	$127/16$	$255/32$

Graph:

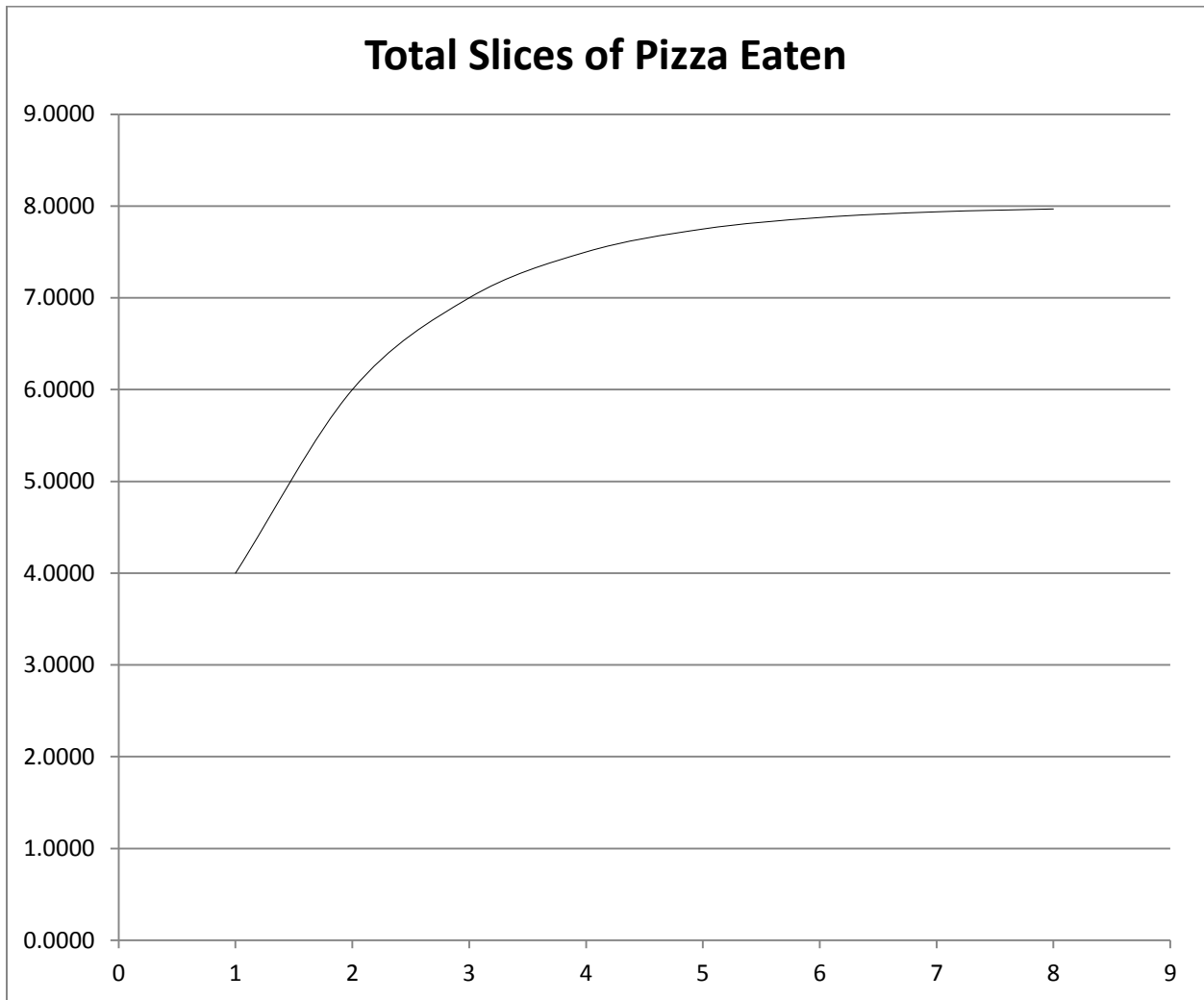

Limit Discussion

You will see in each graph that the graph is approaching a certain y-coordinate but our data tells us that that it will never reach that point. This invisible limit is called an asymptote. In this case, we call it a horizontal asymptote.

Interpretation for this problem: If the man stranded on the island continues to use this eating pattern, he will have pizza until he is saved. He will never run out of food! (Of course, he will starve because $1/256^{\text{th}}$ of a pizza will not fill a hungry stomach.)

Discussion

Most of the lesson will teach itself through discovery.

Key words to mention:

Horizontal Asymptotes

Limits

(Infinite) Geometric Series

Summation

Generalizing

Let's observe the geometric series that we have formulated.

$$\sum_{n=1}^{\infty} \frac{1}{2^n} = 1 \qquad \sum_{n=1}^{\infty} \frac{8}{2^n} = 8$$

In order to create a general formula for converging geometric series, let's adjust these to a standard form by starting with $n=0$.

$$\sum_{n=0}^{\infty} \frac{1}{2^n} = 2 \qquad \sum_{n=0}^{\infty} \frac{8}{2^n} = 16$$

Given a third example of a converging geometric series:

$$\sum_{n=0}^{\infty} \frac{3}{4^n} = 4$$

Can you come up with a general formula for the limit of a converging geometric series?

Answer

$$\sum_{n=0}^{\infty} \frac{1}{2^n} = \sum_{n=0}^{\infty} 1 \cdot \left(\frac{1}{2}\right)^n = 2 = \frac{1}{1/2} = \frac{1}{1-1/2}$$

$$\sum_{n=0}^{\infty} \frac{8}{2^n} = \sum_{n=0}^{\infty} 8 \cdot \left(\frac{1}{2}\right)^n = 16 = \frac{8}{1/2} = \frac{8}{1-1/2}$$

$$\sum_{n=0}^{\infty} \frac{3}{4^n} = \sum_{n=0}^{\infty} 3 \cdot \left(\frac{1}{4}\right)^n = 4 = \frac{3}{3/4} = \frac{3}{1-1/4}$$

For converging geometric series, we have found that, for $|r| < 1$

$$\sum_{n=0}^{\infty} ar^n = \frac{a}{1-r}$$

Geometric Series Exercises

1. A few days later, the man finds 2 rotting moose. It appears as though the moose have been dead for a few days now. After dragging both moose back to his camp, he realizes only about half of one of the moose is edible. The other moose looks perfectly fine to eat. Model the man's eating habits, using a geometric series, so that he only eats the edible parts of both moose.

Answer

Need a geometric series that converges at $1\frac{1}{2}$ (limit = $\frac{3}{2}$).

We found that $\sum_{n=0}^{\infty} ar^n = \frac{a}{1-r}$ for converging series.

So we need $\frac{a}{1-r} = \frac{3}{2} \rightarrow a = \frac{3}{2} - \frac{3}{2}r \rightarrow r = 1 - \frac{2}{3}a$

For simplicity, take $a = 1$ and you get $r = \frac{1}{3}$.

We have the series $\sum_{n=0}^{\infty} \left(\frac{1}{3}\right)^n = \frac{1}{3^n}$

Day	1	2	3	4	5	6	7
Fraction of Moose Eaten	1	1/3	1/9	1/27	1/81	1/243	1/729
Total amount of Moose Eaten	1	1 1/3	1 4/9	1 13/27	1 40/81	1 121/243	1 364/729

2. The man spends the next week capturing flying squirrels. Although they are a fast creature, he quickly realizes the correct tactics for catching them. He waits for the flying squirrel to glide from tree to tree and when they're in the air, he throws a rock at one of their "wings". The squirrels fall to the ground and the man throws them into a cage. After the long week, he has collected 50 flying squirrels. He begins to cook them and on the first day he eats one and a half flying squirrels. He really enjoys this meal, so the next day he eats two and quarter flying squirrels. As you can guess, the man needs to keep his mind fresh because there isn't much to do on the island. So he decides he will continue this eating pattern until he runs out of flying squirrels. That is, each day he will be eat 3/2 of the amount that he ate the day before. On what day will he run out of flying squirrels?

Answer

We have the geometric series: $\sum_{n=0}^{\infty} \left(\frac{3}{2}\right)^n$

Day	1	2	3	4	5	6	7	8
Amount of Fly Squirrel Eaten	1 1/2	2 1/4	3 3/8	5 1/16	7 19/32	11 25/64	17 11/128	25 161/256
Total Fly Squirrel Eaten	1 1/2	3 3/4	7 1/8	12 3/16	19 25/32	31 11/64	48 33/128	73 227/256

He will run out of flying squirrel on Day 8.

3. Create your own story describing a converging geometric series with a limit that is greater than 1.

4. Complete the Table:

Animal Type	Amount Collected on Day 1	Number Eaten on Day 1	Multiple of Prior Day Eaten (/day)	Will he run out of food?	Day of Convergence	Limit of the Series
Rhino	1	2/5	2/5			
Worm	150	5/2	5/2			
Cockroach	75	5	5			
Mouse	20	1	19/20			
Dinosaur	1/5	1/5	1/5			
Pine Cone	1,000	1	1/100			
Dandelion	225	6	6			
J.B.C.	1	11/20	11/20			
Pineapple	3	10/3	10/3			
Finger Nails	10	1	1/10			

Sequences

The goal of this module is to give students a general understanding of sequences and their association with series. This lesson is made in accordance with the series module. Unlike most texts, this model encourages sequences to be taught after series. This unique approach is used with the idea that students are less likely to get series and sequences confused with each other. Furthermore, this approach will prove to prepare students for the type of mathematical thinking that they will see in higher level mathematics courses.

The traditional approach to sequences occurs in Precalculus, directly before series. The concept is introduced as a function with a set of integers as its domain (Larson, 2012). As exercises, students are asked to give the first few terms of given sequences and find the n th term of a sequence of a given list of values. The text goes on to explain different types of sequences such as recursive sequences. Assuming students do not understand notation, Larson's lesson explains factorial and summation notation. Following properties of summations, the lesson moves on to introduce series. After a quick series lesson, the next section jumps back to sequences through arithmetic sequences and their applications. Applications include compound interest, population trends, sales trends, and other general pattern applications. Overall, the majority of examples involve recognizing a pattern and creating the sequence or vice versa. Repetition and studying examples is the focus for students' success in the sequences lesson.

The approach in this lesson is very different. Since students learn series first, they are already aware of the summation and factorial notation. To maintain separation between sequences and series, sequences are introduced as the list of terms in a given series. By doing this, the series is seen as a summation and the sequence is viewed as a list of terms with a pattern. To introduce the idea of a sequence being a set, students are given an example with animals instead of numbers. They are also given the sequence 0, 1, 0, 1..., which allows students to see that a sequence can contain more than one

of the same value. This abstract introduction prepares students for the level of thinking that is required in college level mathematics courses. Furthermore, the continuation of starving man story is designed to maintain the attention of the students.

Another advantageous feature of this sequence lesson stems from its correspondence with the series module. With the high emphasis on graphical representation, the series module helps students in picturing series graphically, as well. This continues the introduction to the limit, which is clearly a significant topic in higher level math.

The philosophy in the following module is similar to Kenneth Rosen's text on discrete mathematics. Rosen introduces sets, followed by sequences, summation notation, then series (Rosen, 2007). Calculus courses tend to use the same approach as the Precalculus course explained above. Sequences are constantly used in Advanced Calculus, Linear Programming, and Mathematical Optimization. Optimization using iterative methods relies heavily on a basic understanding of sequences. For example, Mathematical Optimization uses both Newton's Method and the Method of Steepest Descent, which both create of sequence of values (Peressini, Sullivan, & Uhl, Jr., 1988). The Method of Steepest Descent is best described graphically. In this line search method, the step between the first and second iteration is perpendicular to the step formed between the second and third iteration. This pattern continues until the method reaches the optimal solution of the objective function. Without a graphical representation of this sequence, it is more difficult to understand the inefficiency of the Method of Steepest Descent.

For more abstract mathematics courses, a set is more regularly seen than a sequence. Courses such as Graph Theory, Combinatorics, Rings and Fields, or any course that requires proofs all use the concept of a set. Understanding that a set is not just a bunch of numbers in brackets with commas

separating them is very important. Since these definitions can frustrate an algebra-driven mathematics student, it is important to start introducing this idea at an early stage.

Introduction to Sequences

Recall the starving man on the island from our series lesson. The last exercise contained several series that represented the starving man’s eating habits. He was chowing down on anything from worms to dinosaurs and from Junior Bacon Cheeseburgers (JBCs) to finger nails! The man has realized that he is going to be there for a while. For this reason, he wants to organize his eating habits. He used to observe his grandmother’s organization of pills in an organizer that had a little case for each day of the week. He took this idea and expanded it. He will be portioning out food for the next month in the following fashion.

30 JUNE	1 JULY	2	3	4	5	6
7	8	9	10	11	12	13
14	15	16	17	18	19	20
21	22	23	24	25	26	27
28	29	30	31	1 AUGUST	2	3

The chart above is a giant grid that he made out of fallen trees and branches. The entire grid sits on a big field that he found on the back side of the island. In each square, he will put that day’s meal. The current date is June 30th. The starving man will begin his eating schedule on July 1st. He has decided he’s just going to finish the pizza today and start on the odd foods tomorrow.

It is your job to help the starving man portion out the food for the first week. Every day, we will be feasting on the food that he caught the other day: rhino, worms, cockroaches, mice, dinosaur, pine cones, dandelions, JBC, pineapple, and fingernails. Recall his eating rates of each type of “food” below.

Animal Type	Amount Collected on Day 1	Number Eaten on Day 1	Multiple of Prior Day Eaten (/day)
Rhino	1	2/5	2/5
Worm	150	5/2	5/2
Cockroach	75	5	5
Mouse	20	1	19/20
Dinosaur	1/5	1/5	1/5
Pine Cone	1,000	1	1/100
Dandelion	225	6	6

J.B.C.	1	11/20	11/20
Pineapple	3	10/3	10/3
Finger Nails	10	1	1/10

Exercise

1. Create a grid, for the first week, which is similar to the starving man's on the previous page. Calculate the amount of each "food" item and place the amount in the appropriate day.

Sequences

When you originally worked with the starving man's pizza, you created what is called a geometric series. A series represents a summation of terms. By creating the grid that you have made for each day in the previous exercise, you now have a sequence for each "food" item. A sequence is an ordered set of objects. Here are some examples:

- A. 0, 1, 0, 1, 0, 1, ...
- B. 1, 2, 3, 4, ..., 10
- C. cat, razor, feather, cat, razor, feather, ...
- D. 0, 4, 8, 12, 16

As you can see, order means that the sequence follows a definable pattern. The order of example A can be defined as, "starting with the first term in this infinite sequence as an odd term, every odd term is 0 and every even term is 1". Example C shows that sequences do not need to be numbers.

Exercise

2. Can you define rule for Examples B, C, and D?

Why do we use Sequences?

Sequences are advantageous when we have an ordered set that contains several terms. Often times in such cases we want to find the "nth term". Once we define a rule, or formula, for our sequence, we then have the ability to find any term in the sequence, even if it's 1,000 terms long! Formulas for sequences are defined using n. Here are possible formulas for the previous examples:

- A. For an odd number n, the term is 0. For an even number n, the term is 1. We define this for n from 0 to infinity. We could also express this sequence algebraically: $a_n = \frac{1 + (-1)^n}{2}$
- B. We define this for n from 1 to 10. This sequence can be best described algebraically: $a_n = n$
- C. If n is a multiple of 3: feather; if (n+1) is a multiple of 3: razor; if (n+2) is a multiple of 3: cat. We make these definitions for all n from 1 to infinity.
- D. We define n from 0 to 4. This sequence is best described algebraically: $a_n = 4n$

Exercises

3. Individually define each "food" item in the starving man's diet as a sequence and find a formula to express the nth term. Also, can you find the last term of every sequence?

4. A tsunami hit the starving man's island and washed away his stock of food. It's your turn to go hunting! Search around the island for two week's supply of food. A tree fell on his head during the tsunami, so you're going to have to do the math for him.

Trigonometry

Trigonometry is one of the most revisited subjects in mathematics. Students are first introduced to trigonometry in geometry. It is here where they learn about the useful applications when finding magnitude of sides and angles of triangles. The goal of this module is to revisit sine, cosine, and tangent as functions. Students will learn the origin of trigonometric functions and their application to the unit circle. To bring everything together, geometric applications of each function will also be revisited.

As mentioned, the original introduction to trigonometry appears in standard geometry courses. There is a heavy use of each when making calculations with right triangles. Students revisit trigonometry in Precalculus and learn that it is a periodic function (Larson, 2012). Students learn how to evaluate sine and cosine, while applying these calculations to the unit circle. Following these sections, Larson's text goes on to explain applications such as current circuits, springs, and triangles. After reapplying the functions to triangles, students are taught the graphs of each trigonometric function. Later, the subject of Fourier Series shows us that many periodic functions can be expressed in terms of sine and cosine, with many important applications including signal processing.

This lesson takes an original, yet antique, approach. Students form groups and are asked to use the contraption (Figure 1), representing the unit circle (radius of the inner wheel is one inch). They are instructed to roll the contraption across a vertically standing piece of paper and follow the reflection of the rotating pin to create the following picture (Figure 2). This gets students involved and engaged.

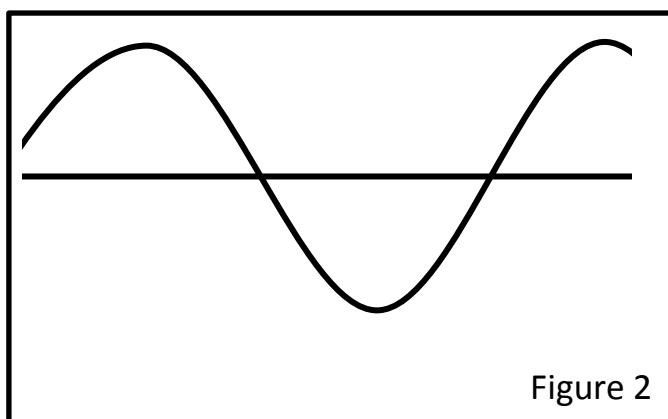
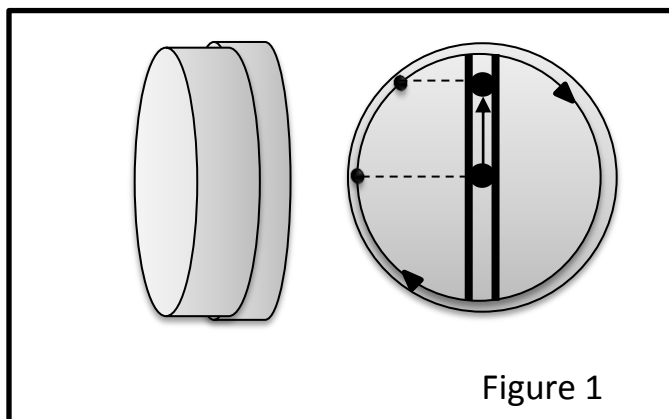

At this time, there is a teacher-led discussion that forces students to define what they have drawn by just the information they know. Students discover the period of the function; the range of the function; and the x-axis in their picture. In this method of discovery, students are creating their own graph where all that is missing is a y-axis. Questions are asked of the students and eventually they realize the connection between this picture and sine and cosine. At this point, the unit circle is an exercise that can be explained differently. No longer is it a series of boring memorizations. The numbers are meant to be the coordinates of the graph that they have created. A student's previous knowledge can also be useful when referring to the degrees on the unit circle. Students have now defined sine and cosine with very little instruction. (For a better picture of the contraption used, see Appendix C.)

An introduction of tangent as the quotient of sine and cosine allows students to create a table of values and graph the function. Similarly, the evaluation of the unit circle follows naturally. Of course, it is important to remind students of the parallels between the graphs of these functions and their applications to triangles. By introducing this in the end of the lesson, students are able to bring everything they have learned about trigonometry together. Furthermore, their understanding is not blurred by calculators. A final homework problem allows students to get creative in their thinking. Furthermore, this assignment ties the entire lesson together in a simple definition.

The motivation for this module comes from the applications of trigonometry in college level mathematics. Although there are application problems that involve triangles, trigonometry's primary application appears in functions of all forms. In calculus, students are constantly asked to calculate the derivative and integral of trigonometric functions. Students are also expected to graph and understand the meaning of their calculations. When cosine and sine are used in application problems, students must recognize that the function is periodic.

Discovering Trigonometry

Activity

Split up into groups. Roll the contraption, representing the unit circle (radius of the wheel is one inch), across a vertically standing piece of paper and follow the reflection of the rotating pin to create the following picture:

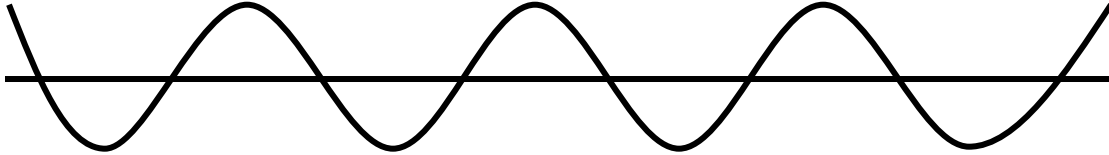

Discussion Questions

- How can we interpret this?
*The straight line is an x-axis.
 The curve is a graphical representation of something.*
- What do we know about units? Can we add numerical value?
*We know the radius of the wheel is 1 inch.
 We also know that the circumference of the wheel is 2π .*
- What are we missing for this to be a graph of a function?
*Although we have a height from -1 to 1, we are missing the y-axis.
 We need to find where $x=0$.*
- What is x representing?
To understand this, we need to go back to the wheel.

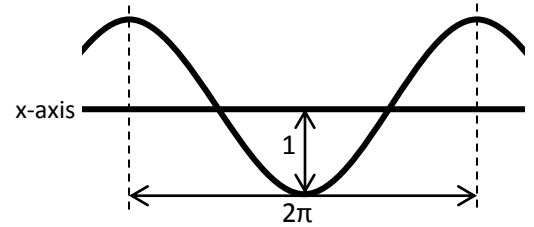

Understanding $x=0$

Observe the diagram to the right and discuss how a and b *actually* represent two different graphs. Students will discover that x is the distance from line c to the horizontal or vertical axis in the diagram.

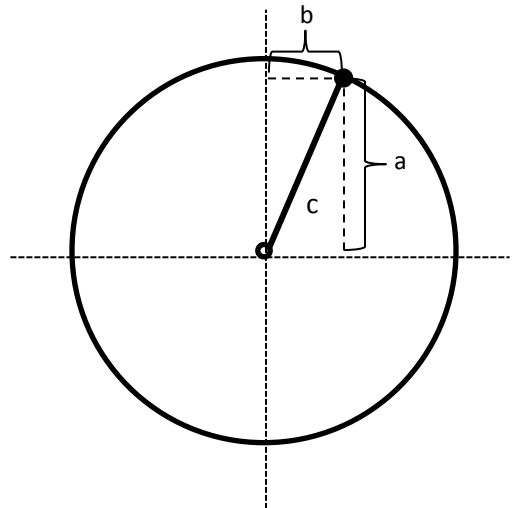

Interpret your Discoveries

- Graph the curve using a

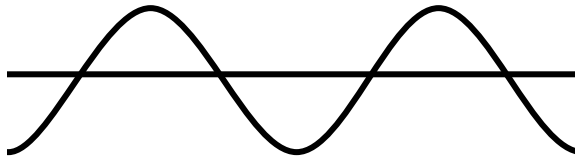

- Graph the curve using b

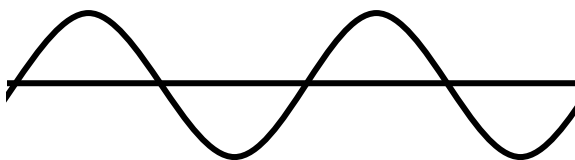

Note: Make sure to include the y-axis in your graph. Think about what it means for $x=0$.

Below, each point on the circle has three parts:

- i. The angle, in degrees, formed by the x-axis and the line connecting the point to the origin.
- ii. The angle, in radians, formed by the x-axis and the line connecting the point to the origin.
- iii. The coordinate of the point given by (b, a), where b and a are the same as the previous page.

Exercises

1. Fill in the missing information.

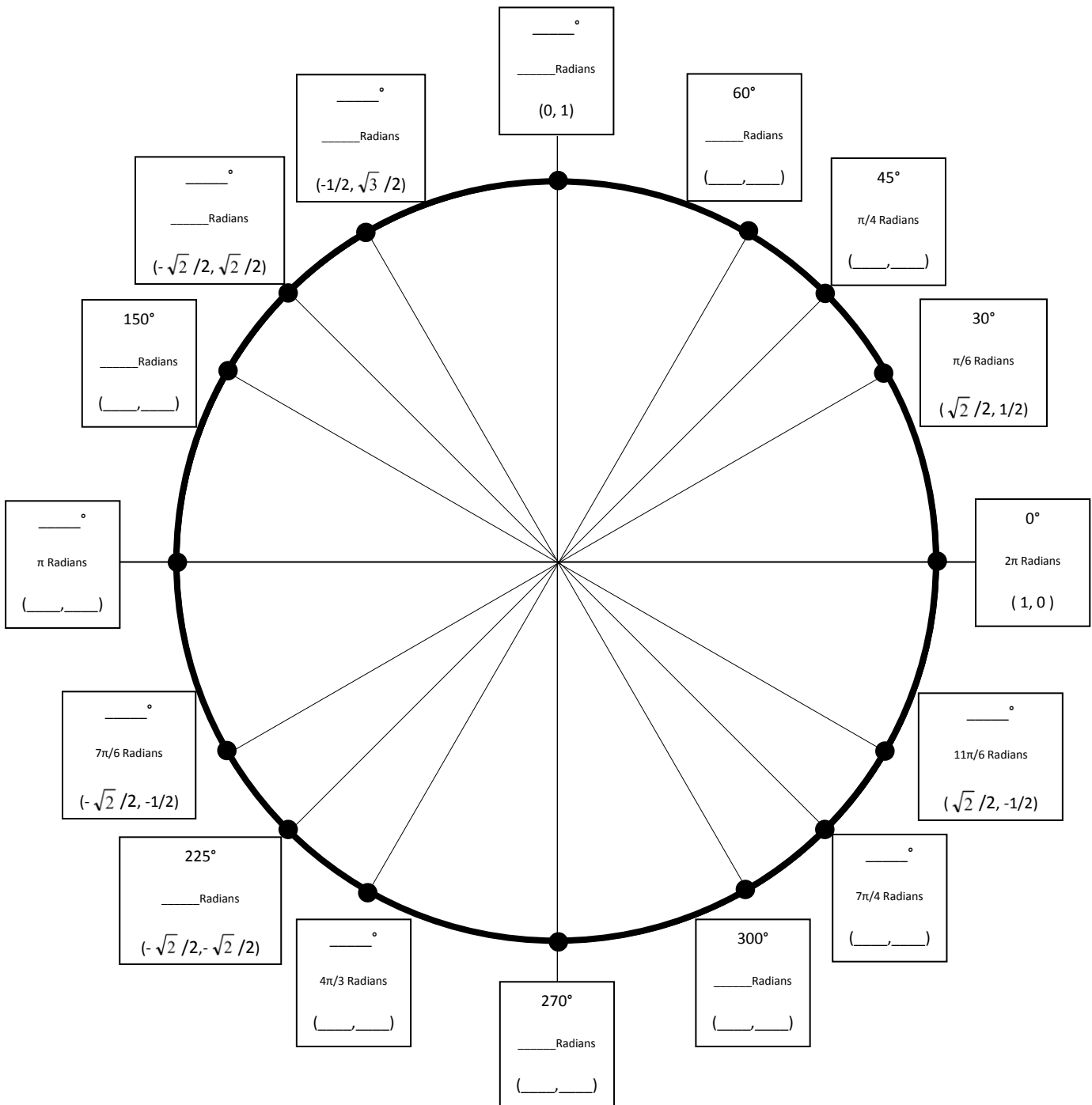

2. As this point, you have probably realized that value a is governed by the sine function and value b follows the cosine function. With that said, can you fill in the values of tangent on the unit circle, given that:

$$\tan \theta = \frac{\sin \theta}{\cos \theta}$$

3. Using what you've discovered, find the graph of the tangent function.

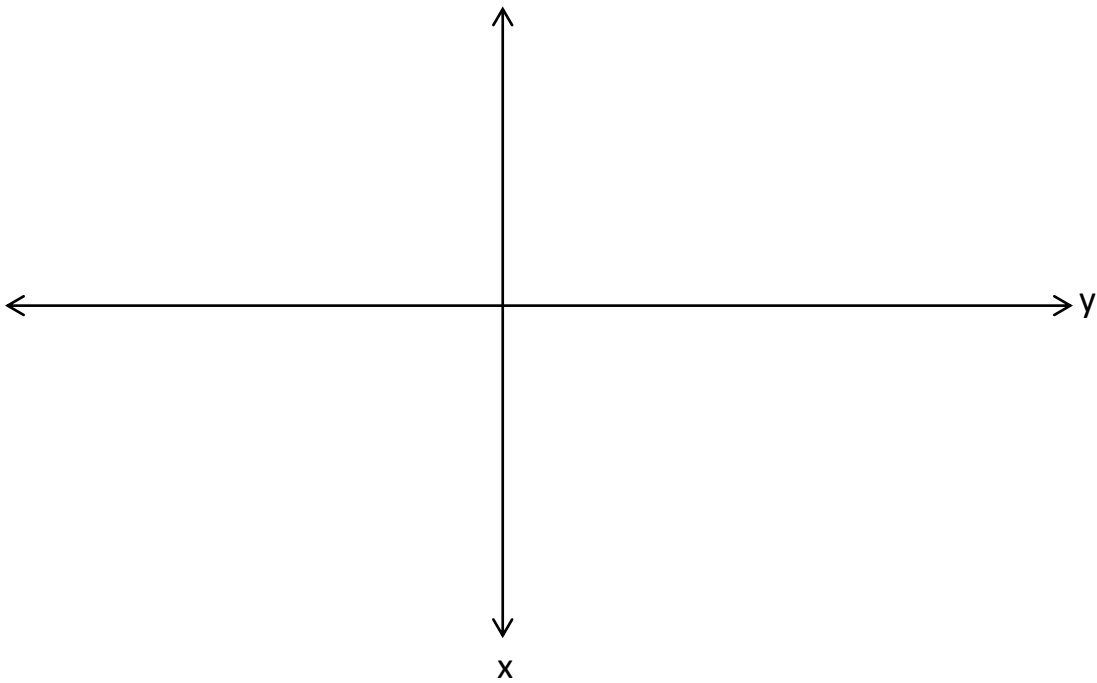

Trigonometric Functions and Triangles

It's time to answer the inevitable question: how does this unit circle and graph stuff relate to the cosine, sine, and tangent that we use for triangles? Let's go back to the wheel diagram.

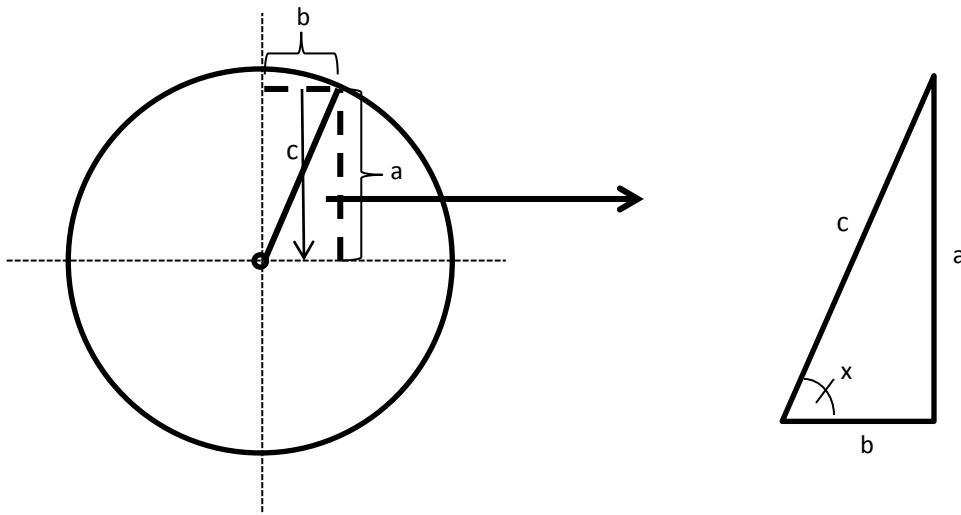

As you can see, we have been working with a triangle all along. What do we know about this triangle?

- The line formed by distance a is perpendicular to the line formed by distance b , which implies that we have a right triangle.
- From the Pythagorean Theorem, we have that

$$b^2 + a^2 = c^2, \text{ and thus}$$

$$(\cos x)^2 + (\sin x)^2 = 1^2 \rightarrow \cos^2 x + \sin^2 x = 1$$

- What about $S = \frac{O}{H}$, $C = \frac{A}{H}$, $T = \frac{O}{A}$? (O=Opposite, A=Adjacent, and H=Hypotenuse)

The length of an adjacent or opposite side is proportional to the radius of the circle, or c , the hypotenuse of the right triangle. Also, if we need to find the hypotenuse, we know this can be found from the definition of the tangent. Therefore it makes sense to represent each by the following:

$$\sin x = \frac{a}{l} = \frac{a}{1} = a ; \quad \cos x = \frac{b}{l} = \frac{b}{1} = b ; \quad \tan x = \frac{\sin x}{\cos x} = \frac{a}{b}$$

Remember why these trigonometric identities are helpful?

You can calculate all angles and sides of a right triangle when given very little information.

Exercises

Find all remaining angles and sides of the right triangle, given the following information.

4. Hypotenuse: 6 inches; $\theta=55^\circ$

5. Legs: 5 cm and 9cm

6. Angle: $\pi/6$; opposite side: 6 inches

7. Hypotenuse: 5 inches; leg: 3 inches

8. Legs of equal length: 7mm

Bonus Question

The origin of sine goes all the way back to the word jiva, meaning bowstring (Sanskrit). Can you figure out how a bowstring relates to the sine function?

Hint: Look back at the first picture of the unit circle on the first page.

Results

Extensive research by engineers, professors, teachers, mathematicians, scientists, and many more has revealed that STEM education is more important than ever at this time. Studies in colleges and high schools around the United States suggest that students need more assistance in these fields. This has been the motivation to create these innovative teaching modules. The new approach gives students a different outlook on math education. As you will see, these modules also give students a more thorough and beneficial understanding of their given topics.

The sequences, series, logarithms, and trigonometry modules were all taught at North High School. North High School has been home to thousands Worcester County students. Best known for its extracurricular activities, North High holds just over eleven hundred students. The school is viewed as very run-down and in need of some improvement. That, along with its twentieth century dynamics, is why a new building was built this past year. Statistics have shown that Worcester North struggled with attendance as the 2007-2008 school year progressed (SchoolFusion.com, 2012). The majority of kids are Hispanic or White/Caucasian, followed by African American and Asian or Pacific Islander. Although diversity is common at Worcester North, wealth is not. Just over seventy five percent of the students are eligible for free or reduced lunch. Eligibility for free or reduced lunch is based on family size and household income. Teachers at North High also encounter students who have difficulty speaking English. With around fourteen percent of the school's students having limited proficiency in English, North High School is forced to employ faculty members that can translate for students and their parents. Furthermore, more than twenty two percent of students require special education (Worcester Public Schools, 2010).

When approaching North High School students with these teaching modules, all of the preceding factors were considered. Lessons were taught in three College Algebra II courses and one Precalculus course. Before each lesson began, students were given five minutes to answer a three or

four question pretest, individually. These pretests asked for basic knowledge in the topic to be discussed. The pretests were important in determining how much students already knew about the topic. Two weeks following the day of the lesson, students were given a posttest. The posttests were identical to the pretests. All of the information needed to answer the pre/posttests was given in the lesson. The posttests were designed to test retention of a basic understanding.

Overall observations of the courses taught were positive. Each class had a few students that did not involve themselves, while a few students jumped to answer every question. The majority of students were attentive and followed along with the lesson. The lessons were teacher-led discussion but students were encouraged to work in groups for the exercises. Almost all students took advantage of the groups and involved their peers. Although the lessons are detailed with descriptions, the experience was a lesson in itself.

The logarithms module was taught to a total of seventy one students, spread over three separate Algebra II courses. The class was nearing the end of a chapter in which they had just discussed logarithms. Their knowledge was fresh in their minds and they were expecting to be tested on logarithms within the next week. Yet, pretests suggest little to no comprehension of logarithms. Only half of the students could evaluate a simple logarithm (Appendix A). Most of the students were in their third year of high school. For this reason when the lesson began, they enjoyed the story of a freshman seeking high school popularity. They were very intrigued, at the freshman's expense. Following the lesson, students were given homework which involved an application of logarithms to the Richter scale. Two weeks later, thirteen students recalled that an application of logarithms was the Richter scale (Appendix A). The posttests show that the number of students who could name an application of logarithms doubled after the lesson. As previously discussed, students maintain a higher level of interest in subjects they find applicable.

A Precalculus course was taught series and sequences using the modules created in this project. This class was small with eight to eleven students. Students ranged from juniors to seniors. Prior to the lesson, most students had never been exposed to sequences or series, as the pretests confirm (Appendix A). The students were eager to learn and several were quick to grasp the concept of geometric series. It was apparent that they had worked with patterns in previous math courses. A key factor in gaining their attention was investment in the ridiculous, entertaining story. The sequences module directly followed the series module the next day. Since sequences are introduced as a list of terms in a series, the concept was not difficult for the students. Yet, students embraced the challenge when asked to define an order for the sequence cat, razor, feather, cat, razor, feather.... The posttests show a significant improvement in students' ability to distinguish between series and sequences. There was approximately a forty percent class improvement. Furthermore, in answering the question on where series and sequences differ, this forty percent of students was able to define both correctly.

Seventy students over three Algebra II courses were taught using the trigonometry module. The previous knowledge for these students in trigonometry primarily stemmed from geometry. A thorough revisit of trigonometric functions had not yet been conducted in another course. This may explain why sixty four percent of students were unable to answer, "What does a sine curve look like?" (Appendix A) Going further, five students expressed the answer to "What is $\sin(\pi)$?":

$$\text{Sine} = \frac{\text{Opposite}}{\text{Hypotenuse}} \text{ (This is referencing triangle trigonometry, which students were taught in geometry.)}$$

The goal of the trigonometry module was to rediscover trigonometric functions as the graphs they produce. The lesson began with a model of an oscillating function designed using a unit circle, as suggested in the module. Students were quick to point out the height and period of the function, as well as the x-axis. Slowly, the lesson successfully continued, with increasing student interest. After the

majority of time spent on cosine, sine, and the unit circle, the introduction of tangent was taken very intuitively. The posttests given two weeks after the lesson show a significant increase in trigonometric knowledge. Seventy four percent of students drew an oscillating function when asked what a sine curve looked like. This was a three hundred percent increase from the pretest. The number of students to correctly evaluate the sine function at π tripled (Appendix A). After being taught this lesson, it is clear that these students have a better understanding of sine, cosine, and tangent as functions, along with their applications to triangles.

Overall, several studies suggest that research-based learning is the most successful form of educating students. This research has shown that there is room for improvement and these modules suggest a step in the positive direction. A new perspective on the teaching of mathematics is being encouraged all around the United States. The government, teachers, and even employers are pushing for America to try new things in STEM education. Stories, applications, and discovery are only a few possibilities in drafting the new STEM look. More directions can be taken; more skills can be taught.

Looking forward, there are several topics that can be made into creative lessons. All of the following are great topics to choose from:

- Proofs
- Polar Coordinates
- Limits
- Fractals
- Euler's Equation
- Fundamental Theorem of Algebra
- Golden Ratio
- Cryptology
- Vectors/Matrices

Bibliography

- Andrade, J. (2009). *What Does Doodling do?* Plymouth, England: John Wiley & Sons, Ltd.
- Arena, F. E. (2006). *Quadrant Office*. Retrieved February 20, 2011, from Worcester Public Schools Web site: <http://quadrant-office.worcesterschools.org/>
- Bornstein, D. (2011, April 18). A Better Way to Teach Math. *The New York Times*.
- Brown, S. (2011, September 2). What we learn from doodles. *CNN*.
- Brown, S. (n.d.). *Infodoodler Showcase*. Retrieved March 28, 2012, from The Doodle Revolution: <http://sunnibrown.com/doodlerevolution/showcase/>
- Chartrand, G., Lesniak, L., & Zhang, P. (2011). *Graphs & Digraphs, 5th ed.* Boca Raton: Taylor and Francis Group, LLC.
- COMAP. (2012). Retrieved March 27, 2012, from Consortium for Mathematics and Its Applications: <http://www.comap.com/index.html>
- Davis, P. (2009). *Differential Equations: Modeling with MATLAB*. Upper Saddle River: Prentice-Hall, Inc.
- Edwards, C. H., & Penney, D. E. (2008). *Calculus: Early Transcendentals, 7th ed.* Upper Saddle River: Pearson Prentice Hall.
- Egan, L. H. (1999). *25 Super Cool Math Board Games*. New York: Scholastic, Inc.
- Emdin, C. (2011, November 15). Five Reasons Why Your Child Won't Be a Scientist (and What You Can Do About It). *Huffington Post*.
- Erickson, A., & Ruskey, F. (March, 2011). *Auspicious tatami mat arrangements*. Victoria BC: University of Victoria.
- Greenberg, D. (1996). *Funny and Fabulous Fraction Stories*. New York: Scholastic, Inc.
- Holdren, J., & Lander, E. (February, 2012). *Report to the President: Enge to Excel*. Washington, D.C.: President's Council of Advisors on Science and Technology.
- Lakatos, I. (1983). *Proofs and Refutations*. New York: Press Syndicate of the University of Cambridge.
- Larson, R. (2012). *Precalculus with Limits: A Graphing Approach, 6th ed.* Belmont: Brooks/Cole, Cengage Learning.
- Lay, D. C. (2003). *Linear Algebra and its applications, 3rd ed.* College Park: Addison Wesley.
- Loy, J. (1997). *Zeno's Paradoxes*. Retrieved April 25, 2011, from Jim Loy's Home Page: <http://www.jimloy.com/physics/zeno.htm>

- Massachusetts Department of Elementary & Secondary Education. (2011, June 16). *Massachusetts Comprehensive Assessment System*. Retrieved April 26, 2012, from Mass.gov:
<http://www.doe.mass.edu/mcas/2011/release/>
- Massachusetts Department of Elementary & Secondary Education. (2011, February 22). *Massachusetts Curriculum Frameworks*. Retrieved April 26, 2012, from Mass.gov:
<http://www.doe.mass.edu/frameworks/current.html>
- Mighton, J. (2011-2012). Retrieved April 20, 2011, from Jump Math: <http://jumpmath1.org/>
- NCTM. (2012). Retrieved March 27, 2012, from National Council of Teachers of Mathematics:
<http://www.nctm.org/>
- Pennell, S. (2012, April 18). Department of Mathematical Sciences, University of Massachusetts Lowell. (R. Varney, Interviewer)
- Peressini, A. L., Sullivan, F. E., & Uhl, Jr., J. J. (1988). *The Mathematics of Nonlinear Programming*. New York: Springer.
- Rosen, K. H. (2007). *Discrete Mathematics and Its Applications, 6th ed.* New York: The McGraw-Hill Companies, Inc.
- Rudin, W. (1976). *Principles of Mathematics, 3rd ed.* Madison: McGraw-Hill, Inc.
- Ruopp, F. N., & Poundstone, P. (2007). *The Math with a Laugh Series*. Portsmouth: Heinemann.
- SchoolFusion.com. (2012). *North High School*. Retrieved September 4, 2010, from
<http://north.worcesterschools.org/>
- Simons, J. (2012). Retrieved March 27, 2012, from Math for America:
<http://www.mathforamerica.org/about-us/mission-and-vision>
- Smith, D. (Director). (2005-2010). *Numb3rs: Television Series* [Motion Picture].
- The Full Wiki. (2012, April 10). *Wikis*. Retrieved April 15, 2012, from Sine Wave: Wikis:
http://www.thefullwiki.org/Sine_wave
- United States Department of Commerce. (2011, July 14). New Commerce Department Report Shows Fast-Growing STEM Jobs Offer Higher Pay, Lower Unemployment. *Commerce.gov*.
- United States Department of Labor. (2011, April 8). College Enrollment and Work Activity of 2010 High School Graduates. *Bureau of Labor Statistics*, p. 5.
- unknown. (n.d.). *The Limit Paradox*. Retrieved April 25, 2011, from Math Pages:
<http://www.mathpages.com/home/kmath063.htm>

USGS: Earthquake Hazards Program. (2012, April 24). Retrieved April 24, 2012, from Earthquakes Worldwide in the Last 30 Days: <http://www.iris.edu/seismon/last30.html>

Vanderbei, R. J. (2008). *Linear Programming: Foundations and Extensions, 3rd ed.* New York: Springer.

Worcester Public Schools. (2010). *Worcester Public School High School Level Improvement Plan 2008-2010 North High*. Retrieved September 5, 2010, from <http://north.worcesterschools.org>

Appendix A

Evaluation Results

Logarithms

Question/Answer

Pretest Posttest

Question 1: What do you know about logarithms?

Can be used to calculate magnitude of an earthquake	0	1
Correct Example	0	1
Form of exponential function	2	1
There are two types: common and natural	4	0
The log is to find the exponent	2	5
Growth by a base of 10	4	5
Correct Definitions	17	18
Incorrect / Not clear insight / IDK / Blank	42	42
Total	71	73

Question 2: What is $\log(\text{base } 10)100$?

I do not have my calculator	1	0
Wrong / IDK / Blank	36	33
2 (correct)	34	40
Total	71	73

Question 3: Can you describe an application of logarithms?

Astronomy	1	0
Population Growth	1	0
Value of a car over time	1	0
To find force	1	0
Calculator	2	0
Example Problem (correctly done)	2	0
Measurements of lightning	2	0
Correct Definition	0	1
Popularity Points	0	1
Investing money with compound interest	1	2
Exponential	4	3
Music / Wavelengths	3	4
Richter Scale / Bacteria Growth / Earthquake	1	13
Incorrect / NO / IDK / Blank	52	49
Total	71	73

Question 4: What is the relationship between exponents and logarithms?

Correct Example	0	3
Exponents is to the raised power, log is to the base power	1	4
Correct Definition	1	6
Inverse	9	3
Opposite / logs find unknown exponent	7	8
Wrong / IDK / Blank / Not clear insight	53	49
Total	71	73

Sequences

Question/Answer

Question 1: Can you give me an application for sequences?

	<u>Pretest</u>	<u>Posttest</u>
Example of a sequence	1	2
Some sort of prediction / pattern	2	2
IDK / NO / Incorrect / Bank / Not clear insight	5	7
Total	8	11

Question 2: What is the difference between series and sequences?

Series is an ongoing pattern	1	0
Series is adding sequences	0	1
Series is definite numbers but sequence is prediction	0	1
Series adds, sequences lists (commas)	0	3
Blank / Incorrect / Not clear insight	7	6
Total	8	11

Question 3: Can you define convergence?

When $r < 1$ (referring to the geometric series formula)	0	1
The value at which a sequence appears to converge to	0	1
Something coming to a point but doesn't really touch	0	1
Combining of two things or multiple things	1	1
2 things come together	3	2
IDK / Wrong / NO / Blank	4	5
Total	8	11

Series

<u>Question/Answer</u>	<u>Pretest</u>	<u>Posttest</u>
Question 1: What is a series?		
Sequence of (related) numbers with a pattern or formula	4	1
Sum of a sequence of numbers	0	4
IDK / Wrong / NO / Blank / Not clear insight	7	6
Total	11	11
Question 2: Can you give me an application for series?		
Half-Life	1	0
Jail break an iPhone	1	0
Take inventory in a matrix	1	0
Predict the outcome of an action	1	0
Example of a Sequence	1	0
Predict a total after a certain time	0	1
Use what you got for previous n to get the next	0	1
Example of a series	0	1
Geometric Series Formula	0	2
Finding Patterns	1	2
IDK / Wrong / NO / Blank / Not clear insight	5	4
Total	11	11
Question 3: Can you define convergence?		
Approach a common center	1	0
Combining series	1	0
When $r < 1$ (referring to the geometric series formula)	0	1
When a series appears to meet a specific value	0	1
Combining of two or multiple things	5	4
IDK / Wrong / NO / Blank / Not clear insight	4	5
Total	11	11

Trigonometry

Question/Answer

	<u>Pretest</u>	<u>Posttest</u>
Question 1: What does a sine curve look like?		
Correct triangle trig	3	0
Horse Shoe / Parabola	3	0
Correct curve (starts at 0 and increases, then oscillates)	5	4
Some sort of unlabelled, oscillating representation	14	41
Incorrect / Blank	45	16
Total	70	61
Question 2: What is the difference between sine and cosine?		
Opposite	1	0
I forgot, I learned last year. I know how to figure it out on my calculator	1	0
Correct Graphical representation of both	0	1
Correct representation of unit circle	0	1
sine starts at 0, cosine starts at 1	2	3
Correct triangle trig	10	19
Blank / Incorrect	56	37
Total	70	61
Question 3: What is the sine(pi)?		
Input pi and hit sine on a calculator, it will tell you	1	0
Opposite/Hypotenuse	5	0
0 / 90 degrees	4	12
0.0548	5	14
Blank / Incorrect / Not clear insight	55	35
Total	70	61

Appendix B

Evaluations

Evaluations

For each lesson, I would first conduct a pretest. Two weeks after the conducting the lesson, I would conduct a posttest. The question(s) would depend on which lesson I am teaching.

The making and use of these evaluations were approved by the WPI Institutional Review Board (IRB).

Series

- What is a series?

- Can you give me an application for series?

- Can you define convergence?

Sequences

- Can you give me an application for sequences?

- What is the difference between series and sequences?

- Can you define convergence?

Logarithms

- What do you know about logarithms?

- What is $\log_{10}(100)$?

- Can you describe an application for logarithms?

- What is the relationship between exponents and logarithms?

Trigonometry

- What does a sine curve look like?
- What is the difference between sine and cosine?
- What is $\sin(\pi)$?

Appendix C

Trigonometry Module Tool

