

Worcester Polytechnic Institute Digital WPI

Interactive Qualifying Projects (All Years)

Interactive Qualifying Projects

April 2008

Hands-On Museum Exhibit

Tri Quang Dang
Worcester Polytechnic Institute

Follow this and additional works at: <https://digitalcommons.wpi.edu/iqp-all>

Repository Citation

Dang, T. Q. (2008). *Hands-On Museum Exhibit*. Retrieved from <https://digitalcommons.wpi.edu/iqp-all/85>

This Unrestricted is brought to you for free and open access by the Interactive Qualifying Projects at Digital WPI. It has been accepted for inclusion in Interactive Qualifying Projects (All Years) by an authorized administrator of Digital WPI. For more information, please contact digitalwpi@wpi.edu.

Hands-On Museum Exhibit

“Party developer” model

Tri Dang

2008

Abstract

Agent-Based Modeling has been known as an alternative scientific method to explain complex behaviors. This Interactive Qualifying Project investigated this theme to build a “learning-by-doing” model that can provide an understanding and a simulation of a phenomenon, how partygoers form smaller groups in a party. Provided a current gradual loss of interest among patrons, through the accomplishments of this project, the project introduces to museums another possible solution for their current problem, an interactive exhibit that uses Agent-Based Modeling.

EXECUTIVE SUMMARY

As technology improved at a striking speed in the past three hundred years, many activities, such as visiting museums and going to zoos, have been forgotten. Through research, several factors have been claimed to cause this trend. For example, information can be obtained easily through the internet and many other different sources. People's curiosity has become more demanding. With limited interactions during exhibitions, interest toward museums decreases. In addition, recreation markets have also prospered. One is now provided many options and would prefer her leisure time to be more enjoyable. On the other hand, museums, although are not considered in a golden era, prove to have their own appealing strengths. They remain one of the entertaining yet educating attractions, where families can appreciate their time together while venturing to new and interesting exhibitions. With extensive collection of rare, expensive and interesting resources, museums or similar types of attractions are also frequent destinations for many schools' field trips.

Evidently, this Interactive Qualifying Project (IQP) has ambitious goals. The main purposes of this project are to understand and to promote Agent-Based Modeling, a concept that simple rules applied on an individual agent can result in sophisticated behavior of a system. The objectives are to create an actual model that can explain complex behaviors of a phenomenon, and to determine Agent-Based Modeling's capabilities to explain difficult behaviors. The project also emphasizes the enjoyment gained from interactions with the model and important educational effects of learning-by-doing concept. With those objectives, this IQP and museums share the same goal, an educating purpose. Therefore, the project trusts that its accomplishments can also provide another solution, the concept of interactive exhibitions, to enhance museums' strengths and solve the loss of interest among visitors.

The first phase of this project is to research different factors that cause the decrease in museum's attendance. Through the research, I analyzed and concluded the main causes of this problem. Indeed, the demand for more interactive involvement plays a major role in this decline. Following the analysis, I investigated the concept of Agent-Based Modeling and applied it to

create a “learning-by-doing” example. The later phase of this project involves determining a phenomenon, applying Agent-Based Modeling to explain it, and building the model.

The output of this project is a “Party Developer” model, which is designed to simulate the behavior of partygoers in a generic party. Particularly, the model, by applying few simple rules to agents (in this case partygoers), describes the process of forming smaller groups within a party. Through simulations, one can make interesting discoveries such as what types of groups are usually formed (single-gender, well balanced-mixed, or one-sided mixed), how long it would take for certain size of party to settle into smaller groups, or how easy-going one need to be in order to form well balanced-mixed groups. These findings are not only crucial to social scientists but also beneficial to all who would like to enjoy their party. Through interactions with the model, one can learn to avoid certain factors or to improve certain aspects to make their party more entertaining.

However, “Party Developer” model has a broader ambition. Social scientists can apply the model and agent based theories as a start in eliminating discrimination missions. Indeed, one can observe that many communities have been formed based on several common aspects. For example, there are China towns where the Chinese gather. There are Christian neighborhoods where families who believe in Christian gather. Cultures and religion are certainly important assets but sometimes they are roadblocks for an open minded acceptance. Thus, defining an appropriate level to educate one’s heritages and to promote diversification becomes a sensitive problem. Social scientists can extend the model into a greater version to simulate this behavior, and, through harmless experiments with different settings and rules, they can discover a bottle neck to the solution.

Overall, the project successfully describes the behaviors of group-forming processes in a party. It proves that agent based theories have great capabilities to explain complex phenomenon such as snowflakes and vortex. In addition, interactions with the models results in better educational effects as one can understand and remember more easily with learning by doing methods. Indeed, agent based concepts should be considered a valid alternative method to explain mysteries in this world.

ACKNOWLEDGEMENT

I would like to graciously thank the following organizations and individuals for their help in this project

- Acton Discovery Museum, Massachusetts, for their involvement, including providing feedback and trial exhibition of the model.
- Dr. Michael J. Radzicki from Worcester Polytechnic Institute, my advisor for his support and guidance.
- Kim Hoang, a Vietnamese carpenter, for his time and effort building the model.
- The various individuals, organizations, and universities whose works were cited in this report and provided information essential to my understanding of the project.

Designing interactive model for museum exhibit

A Interactive Qualifying Project Report
Submitted to the Faculty of
Worcester Polytechnic Institute
in partial fulfillment of the requirements
for the Degree of Bachelor of Science

By:

Tri Dang

Date: April 21, 2008

Report Submitted To:

Prof. Michael Radzicki, WPI

Contents

| | |
|--|----|
| Abstract | 2 |
| EXECUTIVE SUMMARY | 3 |
| ACKNOWLEDGEMENT | 5 |
| Table of Figures | 8 |
| Introduction | 9 |
| Visitation trends: Decreasing visitor attendances | 10 |
| Overall View | 10 |
| Causes and Competitive market | 12 |
| A new type of exhibit | 13 |
| Agent-Based Modeling | 16 |
| Agent-Based Modeling approach | 16 |
| History of the Agent-Based model | 16 |
| Agent base model and examples | 18 |
| a. Agent-Based model | 18 |
| b. Examples | 20 |
| Party Developer model | 24 |
| How do people gather into groups in a party and party computer model | 24 |
| a. Rules | 24 |
| b. "Party" model's goals | 27 |
| Party hand on doing model | 28 |
| Game examples | 31 |
| a. Review and initial settings | 31 |
| b. Examples | 32 |
| Appendix | 34 |
| Bibliography | 37 |

Table of Figures

| | |
|--|----|
| Figure 1: Casual Loop Diagram of the attractiveness of museums and other factors..... | 10 |
| Figure 2: Entertainment trends. Courtesy to MORI and UK Council for Museum, Archives and Libraries | 11 |
| Figure 3: Survey visiting Museums and Galleries. Courtesy to MORI and UK Council for Museum, Archives and Libraries..... | 12 |
| Figure 4: Survey of museum visitor's interest. Courtesy to MORI and UK Council for Museum, Archives and Libraries..... | 14 |
| Figure 5: Coway's game called "Life". Courtesy to The Brooking Institution. "The road to agent based model" | 17 |
| Figure 6: Basic rules composed by Wolfram for fluid motion model. <i>A new kind of science</i> . Page 376 | 21 |
| Figure 7: Fluid motion around a solid object. Wolfram, <i>A new kind of Science</i> , page 378..... | 22 |
| Figure 8: Fluid motion. Wolfram, <i>A new kind of Science</i> , page 380 | 22 |
| Figure 9: Fluid motion at step 20000. Wolfram, <i>A new king of science</i> , page 380..... | 23 |
| Figure 10: Plant evolution. Wolfram, <i>A new kind of science</i> , page 400..... | 23 |
| Figure 11: Visual example of Party model | 26 |
| Figure 12: Party Model..... | 29 |
| Figure 13: Party model at different angle | 30 |
| Figure 14: Party model with Aluminum waveform highlighted..... | 30 |
| Figure 15: Front view of "Party" model | 34 |
| Figure 16: Outer frame parameter | 34 |
| Figure 17: Outer frame detailed parameter (excluding thickness)..... | 35 |
| Figure 18: Aluminum Waveform parameter..... | 36 |

Introduction

Humans can be considered the most intelligent race in this planet. They have an amazing characteristic that other species do not have, an ability to apply and to improve tools. In only the past three hundred years, our society has rapidly changed. Many incredible deeds have been achieved such as the creation of the car, invention of the aircraft, and space travel. As a result, our lives have also adapted to the changes quickly, which unfortunately causes us to overlook some well-established activities. One of them is visiting museums and enjoying going out with friends and family, while having a chance to witness what we have read or learned. For that reason, many creative solutions have been discussed, analyzed and tested to revive interest toward museums.

Currently, there are two main trends to understand a phenomenon. A traditional trend applies combination of physics, chemistry, and mathematic to create equations that represent the relationships among various factors involving in the phenomenon. The other trend, agent based theory, is an innovative idea of exploiting the complex characteristic of systems which consist of many individual agents. The principle of the theory is to explain difficult phenomenon using very simple rules applied to each agent, and, provided a sufficient number of agents in a system, these simple rules can result in extremely sophisticated problems.

As a result, the main purpose of this Interactive Qualifying Project (IQP) is researching agent based theory and applying those results to effectively create a model that can explain a phenomenon. Specifically, the project will discuss a Party model which explains the mechanisms of how small groups in a party are formed. Through this research, the project also promotes a concept of learning by doing and presents a solution to help museums to regain their patrons' enthusiasm in this current state: interactive exhibitions.

Visitation trends: Decreasing visitor attendances

Overall View

Currently, most museums all over the world have faced one common problem. There exists an increasing dramatic drop in patron attendance. According to Labor Market Review 2004, visits to the Alexander Graham Bell Museum have decreased 16% to 97900 visitors a year (Breton 2004, Hasler and Mackay 2001). This trend has worried many museums' managers for years due to disfavored outcomes. As interest toward museums declines, total avenues of these attractions meet a huge loss. In order to stay in business, they have no option but reducing employment and increasing ticket price. These methods, however, bring them to a worse position. Museums start to run down as there are is enough staff to take care of the museums' conditions. Patrons with less interest find poor maintenance to the exhibits and increasing prices as other negative factors preventing them from going to the museums. Thus, museums have to again repeat the depressing cycle.

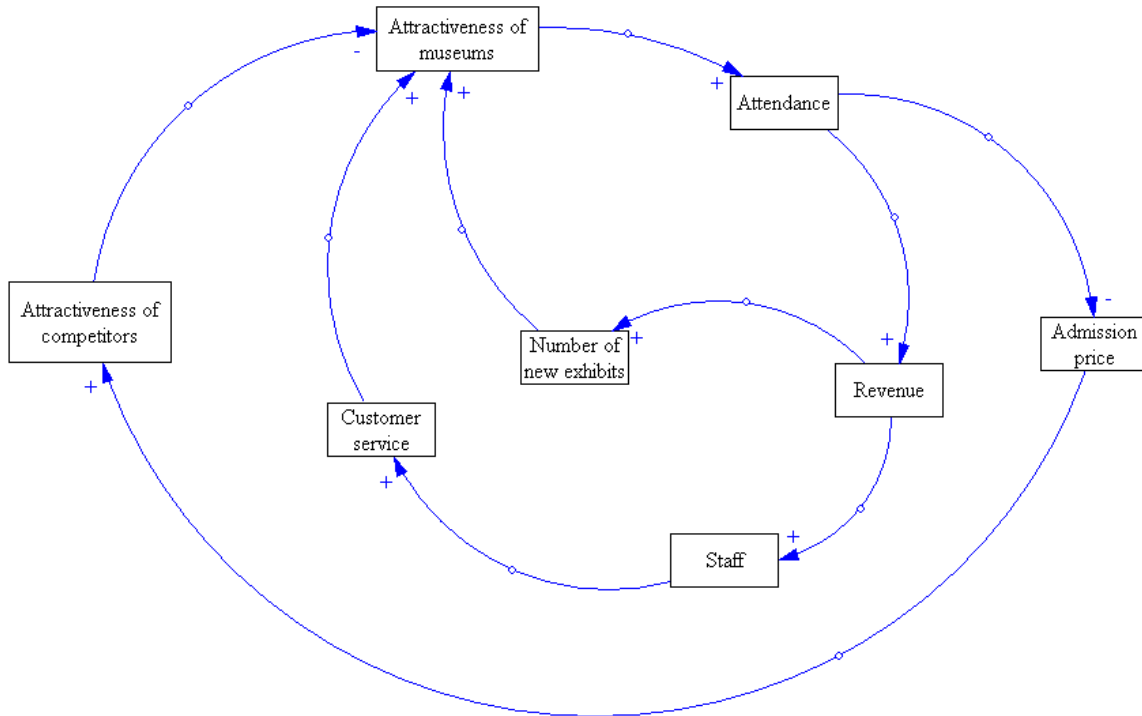

Figure 1: Casual Loop Diagram of the attractiveness of museums and other factors

Figure 1 further demonstrates the relationship between the attractiveness of museums and other factors that was discussed above. In the figure, positive arrows represent positive feedbacks which cause growths or collapse exponentially, while negative arrows represent negative feedbacks which help to stabilize the system. For example, as attractiveness of museums increase, more patrons go to museums. Thus, museums' revenue goes up. Museums then can use the extra cash flow to invest more in new exhibits and in staff. With better customer services and number of new exhibits, museums further gain more attractiveness. Meanwhile, as attendance increases, museums can decrease admission price as they can satisfy the financial needs.

In order to support this argument, several researches have been conducted. The following data was retrieved from the report which was published by the UK Council for Museums, Archives and Libraries in 2001. The data provides a better idea of the current situation of the problem. Specifically, all the traditional recreations such as museums, zoos, and theme parks have experienced decreases in visitor attendance. This fact indicates an alarming trend: people have become more focused in their world and start to avoid open social lives.

Visits to destinations in the past twelve months

| | All Nov/Dec 99 (4,461) % | All Feb 99 (2,454) % | Change +/- % |
|----------------------------|-----------------------------------|-------------------------------|--------------------|
| Base:All | | | |
| Cinema | 52 | 59 | -7 |
| Museum/art gallery | 28 | 35 | -7 |
| Well known park or gardens | 28 | 36 | -8 |
| Stately home/castle/palace | 25 | 32 | -7 |
| Theme park | 25 | 28 | -3 |
| Theatre/opera/ballet | 24 | 30 | -6 |
| Famous cathedral or church | 23 | 32 | -9 |
| Zoo/wildlife park/reserve | 23 | 33 | -10 |
| Live sporting event | 23 | 26 | -3 |
| Pop/rock concert | 16 | 16 | - |
| Classical concert | 9 | 12 | -3 |
| None of these | 20 | 16 | 39 |

Source: MORI

Figure 2: Entertainment trends. Courtesy to MORI and UK Council for Museum, Archives and Libraries

Causes and Competitive market

Unfortunately, there are no specific reasons for the loss of interest in current museums' exhibits. The decline in attendance is a result of a combination of factors. In "Visits to museums and galleries" report, Peter Hasler and Neville Mackay have discussed some of the main issues (Hasler and Mackay 2001):

- As technology improves, transportation among nations becomes easier and cheaper; people prefer spending their vacation abroad to driving 30 minutes to a nearby museum.
- There is an increase in recreation market. People have more options to spend their leisure time such as computer games, cinema, and internet.
- Modern life tends to decrease people's leisure time; thus, people want to spend their time doing more enjoyable activities.

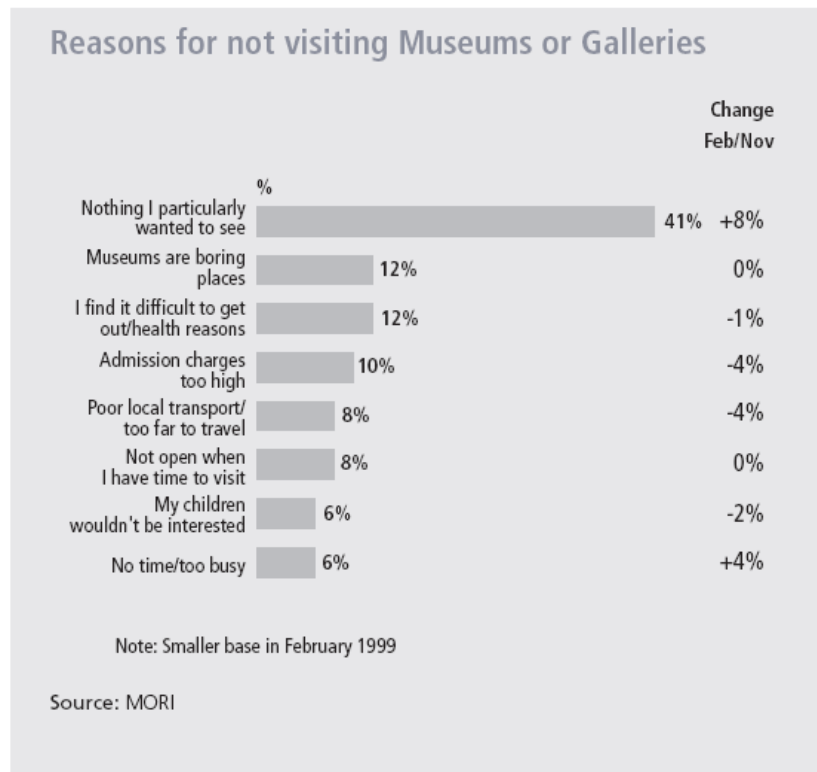

Figure 3: Survey visiting Museums and Galleries. Courtesy to MORI and UK Council for Museum, Archives and Libraries

Figure 3 summarizes the survey, which was conducted in 1999, about some of the main factors causing decreases in attendances of museums and other traditional recreations. From the table, there stands out one clear immediate reason that forms a barrier between patrons and museums. Most people believe they would not find anything particular that they want to see at museums. Patrons get tired of just looking at exhibits. As our society evolves, people become more active. They demand as much experience and interactions in activities that they participate as possible. It is common to see a teenager speeding on the road. It is because youth is desperate for real experience and real sensations. Evidently, that teenager wants to experience the sensation when traveling at a high velocity and to learn his emotional feelings when speeding. Indeed, it is obvious that the best way to learn is having an actual encounter with it. However, some museums can only provide passive interactions with exhibits through the vision sense, which patrons could achieve from staying at home and watching television or surfing through the internet. As a result, the main goal of this paper is investigating agent based theory to create an interactive model. Through the model and this study, museums are provided another possible solution to invest in to solve their current problem.

A new type of exhibit

From the analysis of previous sections, this project proposed one possible solution to museums, creating a new type of exhibit which allows patrons to interact with the models. Indeed, this solution can target a number of discussed problems.

Things that would make visits to Museums and Galleries more enjoyable

| | All responses | Which ONE would you most like |
|--|---------------|-------------------------------|
| Base: All (2,531) | % | % |
| Interactive computer games about the objects on display | 61 | 11 |
| Internet access | 58 | 9 |
| Handle the objects on display | 58 | 11 |
| Working models which young people can use | 54 | 6 |
| A shop selling the sorts of things young people want to buy | 53 | 3 |
| More places to sit and talk | 51 | 3 |
| Staff available to answer questions etc | 51 | 6 |
| Actors in the museum | 44 | 6 |
| Art and craft materials for use during your visit | 43 | 4 |
| Display objects in the setting they would have been found | 40 | 1 |
| Dance and drama programmes for young visitors | 40 | 8 |
| Other young people to guide you around the museum | 36 | 3 |
| The opportunity to be involved in organising displays/ producing labels/writing about the objects on display | 31 | 2 |
| Other | 3 | |
| Don't know/not stated | 16 | |

Source: MORI

Figure 4: Survey of museum visitor's interest. Courtesy to MORI and UK Council for Museum, Archives and Libraries

First of all, it solves the core issue of this phenomenon, reviving patrons' interest in museums. According to the website Engine for Education, learning by doing is proved to be the best way to help one to learn how to do and understand a phenomenon (Engine of Education n.d.). Indeed, in his article "Teaching introductory statistic course so that non-statistician experiences statistical reasoning" Bradstreet has proved this argument:

Learning is situated in activity. Students who use the tools of their education actively rather than just acquire them build an increasingly rich implicit understanding of the world in which they use the tools and of the tools themselves (Bradstreet 1996).

The survey in Figure 4 then further confirms the success rate of this solution. 61% of the responses replied that they would go to museums which have interactive computer games about the exhibits. In addition, 58% of the responses expressed interest in handling the objects on

display. The survey has indeed proved the importance of patron's interactions with exhibits in the mission to regain their interests.

Secondly, the new type of exhibit can be economic depending on the talents of inventors. Museum can expect a low cost but gain a high profit from this solution. In fact, there are some famous museums which already applied this learning by doing idea. Some examples are Museum of Science in Boston, Massachusetts and Discovery Museum in Acton, Massachusetts. They have been researching and building extensive samples and toys to provide patrons more interactive experiences. Lastly, new types of exhibits would have vast areas to invest in such as science, art, history, etc.

This approach also has some drawbacks. Interactive exhibits would require highly innovative ideas to develop. This issue could translate to difficulties in searching for talents and investing with extended time sacrifice to obtain a good model. Some new models can also get costly depending on materials, sizes, and safety requirements. Museums also have to expect more expense from maintenances, security and safety. However this approach remains as the most appropriate solution to our objective at this moment.

Agent-Based Modeling

Agent-Based Modeling approach

Making museums more interesting in order to attract patrons has been a main headache of many museums' managers. There are obviously creative solutions that have been and will be effectively applied. One of the ideas is creating interactive exhibits, where people can interact with the shown objects. Specifically, instead of being separated from the exhibits, patrons can approach these interesting models and, by following the procedures, learn how these models work as well as the phenomenon that is described. Most people come to museums hoping to learn something new. Thus, the exhibits that can promote interactions are proved to be the best structures that can satisfy this need.

As museums become more aware of the benefits of this type of exhibit, the next step is learning how to create an effective model. This IQP, therefore, will discuss one approach to apply this idea, the Agent-Based Modeling. This scientific concept is interesting, and several museums such as Museum of Science in Boston, Massachusetts and Discoveries Museum in Acton, Massachusetts have been successful in using the Agent-Based Model concept to explain some of their exhibits, and receive great acceptance from their patrons.

History of the Agent-Based model

In order to effectively utilize the agent-based theory, a good understanding of this field is required. Thus, this section and the next one will be devoted to a brief explanation of agent based model. The idea of agent based model started in the late 1940s, when mathematician John von Neuman introduced a theoretical machine that is capable of reproduction (The Brooking Institution n.d.). By following precisely detailed instructions, the device can fashion a copy of itself. Von Neuman's and his machines' greatest accomplishment is presenting the implication that the basis of life is information (The Brooking Institution n.d.). That concept led to a number of fascinating researches later on.

The first improvement of Von Neuman's machine was originated from his friend, Stanislaw Ulam. Ulam was an exceptional mathematician with numerous deeds which included the invention of an early model of hydrogen bomb. While von Neuman was doing research on

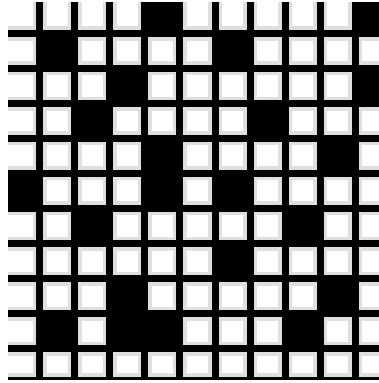

Figure 5: Conway's game called "Life". Courtesy to The Brookings Institution. "The road to agent based model"

his self-replicating machines, Ulam was studying the growth of crystals using a simple lattice network as his model. Ulam, thus, suggested that von Neuman use his model and develop the self-replicating machine around a mathematical abstraction on paper, as a collection of cells on a grid. As a result, Neuman and Ulam created a device that was later called cellular automata.

In 1970, John Horton Conway further improved this concept and created a game called "Life" which is also a cellular automaton. In the game, he introduced a few surprisingly simple rules, yet they created a complex system that is proved to generate an infinite population given any finite configuration. Figure 5 below shows one of many configurations of the game.

- 1st rule: Life occurs on a virtual check board. Each square is a cell, which is either dead or alive. Each cell has 8 possible neighbors.
- 2nd rule: A cell which is alive will live on the next step if 2 or 3 surrounding cells are alive. The cell will die if more than 3 neighbors are alive or less than 2 cells live.
- 3rd rule: A cell which is dead will become alive only when there are exactly 3 surrounding cells that are alive.

Conway's research had a profound effect on the creation of agent-based model. At a first glance of this model, many will think that it would most likely result in all dead cells. Surprisingly, Conway's game is an ever-lasting model; there are always alive cells thus, the game keeps going. It established the new idea that although life is complex model does not have to be (The Brookings Institution n.d.).

Scientists such as von Neuman, Ulam, and Coway have made big contributions to agent-based model's birth. However, from the time that von Neuman introduced his idea to the current time, agent-based models have been developed into various forms thanks to a number of researchers. Cellular automaton was no longer the only entity of agent-based model, but one of many forms of the theory. For example, John Holland, a current professor of University of Michigan and Santa Fe Institute, has developed a new concept to agent-based model, which is called Echo simulation (Holland 1994). Another notable accomplishment is the creation of agent-based models of social systems, which is often credited to the computer scientist, Craig Reynolds. Reynolds, along with other researchers, has applied the concept of agent-based model to model the reality of lively biological agents. Thanks to his work, agent-based model became one of the foundations for artificial life researches.

When mentioning agent-based model, one can not overlook the contributions of Stephen Wolfram to the field. He is the creator of a new kind of science and a powerful mathematical program called Mathematica. In his book "New kind of science", Wolfram has again proved that complex behaviors can also be explained by very simple rules instead of mathematical explanations that the traditional science pursues. In 1970s, he discovered some of principle phenomena that can validate this idea. However, due to a lack of a powerful computer program, Wolfram could not invest more into this field until 1991. The birth of Mathematica, which was created by Wolfram, has helped him enormously to develop the agent-based model into an interesting powerful field as it is recently (Wolfram, A new kind of Science 2002).

Agent base model and examples

a. Agent-Based model

Our existing science has followed a trend of describing any phenomena through mathematical equations. Unfortunately, there are a number of problems which cannot be fully explained through this trend. Such examples are the mysteries of fluid flow, the behaviors of financial systems, and the evolutions of biological world.

Fortunately, those problems can be understood easily through the idea of agent-based model. In 1991, using the powerful math program Mathematica, Stephen Wolfram increased the capabilities of agent-based model greatly to explain the natural world. The

principle concept is applying simple rules to individual agents, which together make of a system. With a large number of agents interacting with each other, a complex behavior is created. The revolutionary idea is that agent-based model has escaped the traditional intuition. Scientists usually expect a sophisticated rules and computations to understand sophisticated phenomena. Yet, while maintaining the logical reasoning, agent-based model proved the opposite concept. Evidently, a system consists of a number of smaller units. For example, a tissue is made of millions of cells. A number of partygoers gathering together form a party. A broader reasoning thus would be many systems, interacting with each other, create our world. Following this analysis, studying the behaviors of microscopic units of a system or an organization to understand the complex behavior of the system or organization is indeed a valid approach.

In addition, agent-based model also has another advantage over the traditional science. Although agent-based model can explain many difficult problems its concept is rather general. Therefore, agent-based model can be reapplied easily when researching a new issue with less initial challenges and costs at the beginning of a project than traditional approach requires. Indeed, agent base model is rather a powerful tool as Wolfram has stated in his “New kind of science.”

The new kind of science that I describe in this book introduces what are in a sense much more general abstract system ... But from the Principle of Computation Equivalence there also emerges a new kind of unity: for across a vast range of systems, from simple program to brains to our whole universe (Wolfram, A new kind of Science 2002).

As mentioned in the previous section, current agent-based model consists of various forms such as cellular automata, echo simulation, individual-based models, etc. Each form has been developed to explain different phenomena. For example, cellular automata are usually applied in computability theory, mathematics, theoretical biology, and microstructure modeling. Cellular automata consist of regular grids of cells. Each cell is always in one of finite defined states. In Conway’s game, there are two states for a cell which are dead or alive. The grid can be in any finite number of dimensions. In a

cellular automaton's simulation, time is also discrete. The state of a cell in one step is defined based on a function of the states of a finite number of cells at the previous step. All cells have the same rules for applying, based on the values in the neighborhood. All the examples, provided in this IQP, are from Stephen Wolfram's book, *a new kind of Science*, and thus are under this form, cellular automata.

Individual-based model are simulations based on the global consequences of local interactions of members of a population. Each agent in this type of simulation can represent an animal in the ecosystem, a vehicle in traffic, or a person in a crowd. Individual-based models usually consist of an environment or framework in which the agents interact with each other. The agents are defined in term of their behaviors, which are explained by procedural rules, and characteristic parameters. Individual-based models' simulations are tracked through time (Reynolds 1999).

Echo, introduced by John H. Holland, is a simulation tool developed to investigate the mechanisms which regulate diversity and information-processing in systems comprised of interacting agents or complex adaptive systems. Echo's agents who are encoded with rules interact with each other via combat, trade, and mating. They develop strategies to ensure survival in a resource-limited environment. In an echo simulation, the population of these agents is the outcome of their interacting networks which regulate the flow of resources. Scientists can apply echo simulation with varying parameters and initial conditions to determine different results of what-if experiments (Holland 1996).

b. Examples

In order to provide a better understanding and proofs of agent base model, this section presented a few examples that Wolfram explained thoroughly, yet the traditional science has encountered many difficulties in explaining them. As mentioned above, many of such striking phenomenon relate to fluid motion. It has been years since scientists tried to understand the random shapes of falling water stream or the behavior of Vortex Street. Yet, agent-based model can describe this problem as a simple matter. At a microscopic level, physical fluids consist of large numbers of small particles moving and colliding with each other. Thus, in Wolfram's fluid motion model, one can have a large number of

particles moving around and colliding on a fixed discrete grid governed by simple rules. Figure 6 below shows the patterns of the particles' next stage provided the scenario of the previous stage.

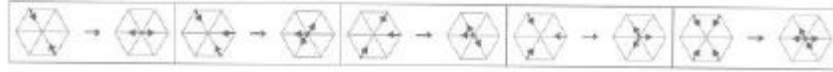

Figure 6: Basic rules composed by Wolfram for fluid motion model. *A new kind of science*. Page 376

Although these rules are made up by human reasoning, not actual natural patterns, they are logical. For example, in the first triangle, at the first stage, two opposite particles are heading to each other. Following the rules of physics, Wolfram has them meet at the center and point out at their next stage as the natural laws would have two particles bounce back after colliding each other.

Surprisingly, even with such simple rules, the results can be dramatic. Figure 7 gives an example of an outcome created by following these rules, the behavior of a fluid motion around a solid object. The pictures in the first row show four continuous steps of a simulation of the behavior. Looking at the lower left picture in Figure 7, one can see a collection of moving particles. As she zooms out more and looks at the average motion of an increasing number of particles in the lower middle and the lower right pictures, she now recognizes the smooth and continuous behavior that is usually observed in a fluid motion. If the speed of the flow is increased, the result is the vortex street as shown in Figure 8 and Figure 9.

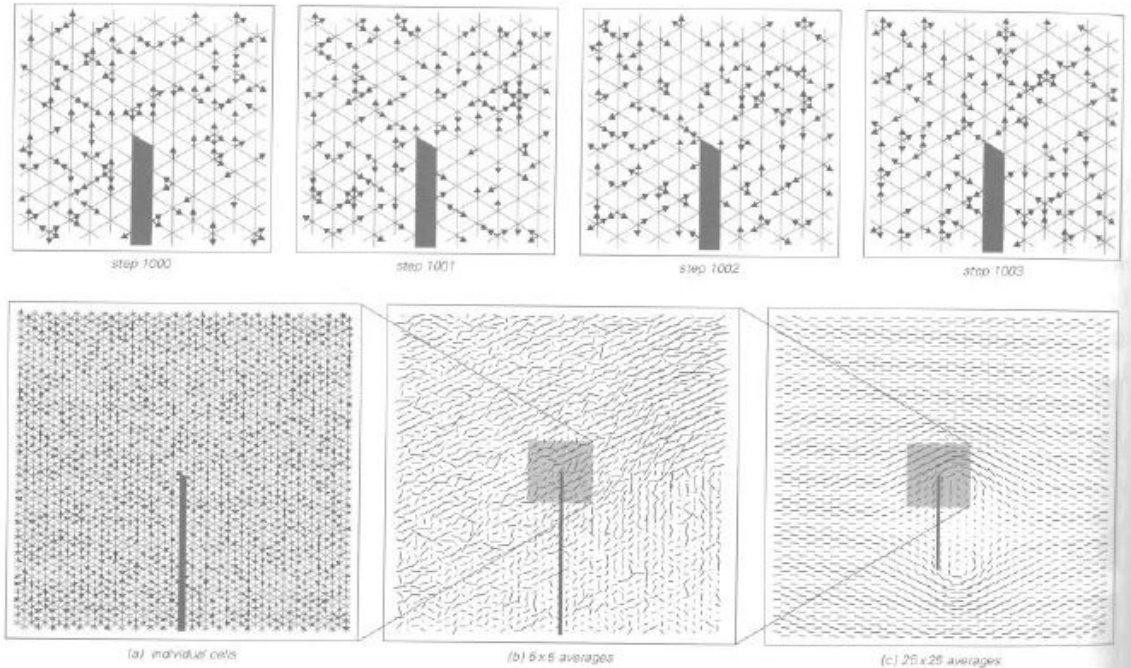

Figure 7: Fluid motion around a solid object. Wolfram, *A new kind of Science*, page 378

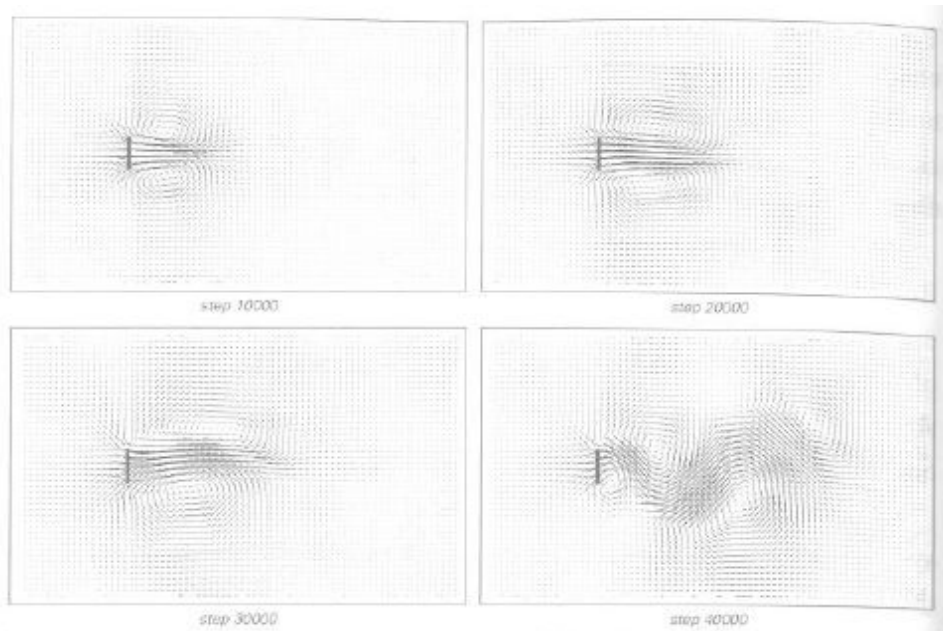

Figure 8: Fluid motion. Wolfram, *A new kind of Science*, page 380

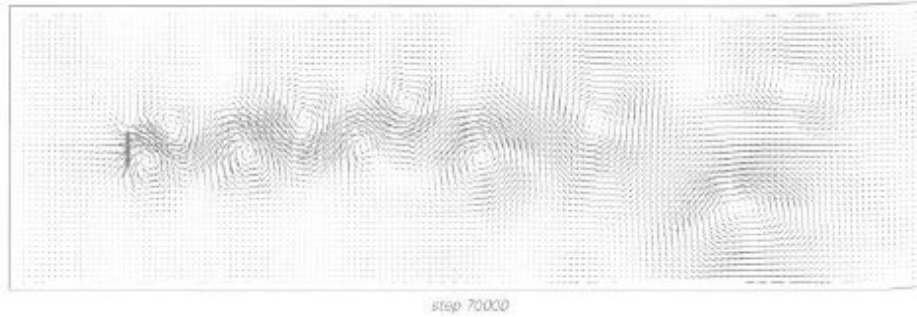

Figure 9: Fluid motion at step 20000. Wolfram, *A new kind of science*, page 380

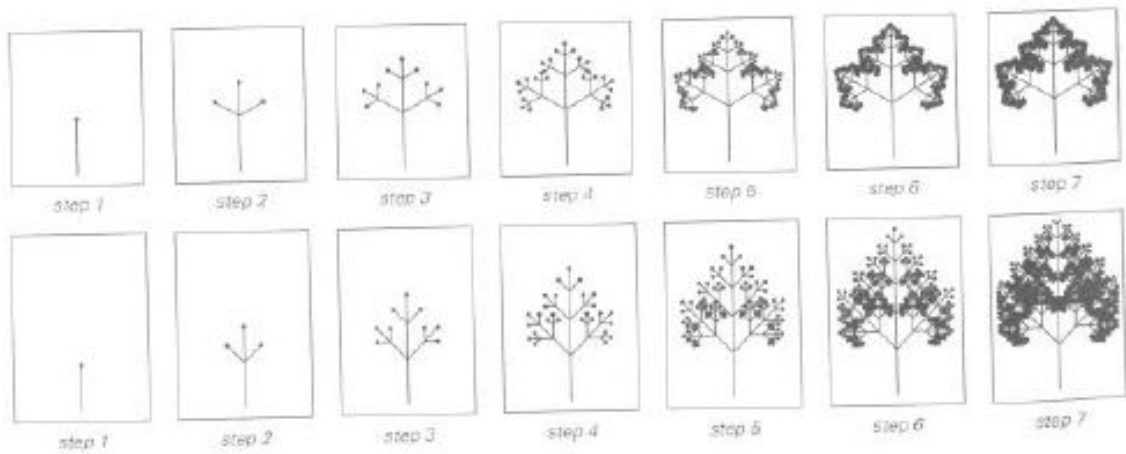

Figure 10: Plant evolution. Wolfram, *A new kind of science*, page 400

Astoundingly, agent base model does not limit its advantages around physical mysteries. The idea is also a key solution to many biology systems and behaviors. Typically, it is thought that the complexity of biological world is the consequences of unique evolving and adapting process. One example is the growth of plants. Provided various forms of plants, one might assume that explanations for their growths must be highly complex. However, Wolfram has discovered that even by following simple rules, plants can still obtain complex plant formations. The pictures below are two examples of such systems.

In both cases, the rule is that every stem in effect branches into exactly three new stems at each step. Yet, after step 7th, one can no longer see any simplicity. This again proves that despite the great simplicity of the underlying rules, agent-based model can indeed create and explain many considerably complex systems.

Party Developer model

How do people gather into groups in a party and party computer model

Up to this point, the IQP has discussed the background, explained the concept of agent-based model, as well as provided some examples that agent-based model can explain. Previous sections also introduced and analyzed the gradual loss of interest toward museums. Thus, readers are now led to the final phase of this project which is applying our research and ideas to create a model for an exhibit using Agent-Based Modeling. Due to constraints of time and fund, our choices of models were limited to simple phenomena which are easy to simulate. As a result, a process of forming smaller groups of partygoers in a party was selected as a subject to experiment the use of Agent-Based Modeling to create an interactive model for an exhibit. For the sake of clarification, this model belongs to individual-based model category.

a. Rules

The model resembles what usually happens in a party. A party is almost always made of groups of men and women, where at first they are mixed together. However, after a while, people tend to gather in smaller groups. The idea is to apply agent-based model to simulate the group-forming process in a party. For example, one can wonder what types of group will turn out or if the most common group is single-gender or well-mixed. Questions such as how long it takes for partygoers to choose their preferred groups or how people get together are also explained from this model.

The rules of this model are based on a modifier called tolerance (Netlogo Models Library 1999-2007). Similar to the reality, the partygoers who are individual agents in this model have a tolerance:

- Tolerances define the partygoers' comfort levels with a group that includes opposite gender people. Tolerance value varies from 0%, where everyone is shy and only stays with people that have the same gender, up to 100%, where everyone is happy with their current group regardless of the group's configuration (Netlogo Models Library 1999-2007). If partygoers are in a group that has more opposite sex members than their tolerances allow they will be uncomfortable, thus, decide to leave that group.

- Once a partygoer is already in a group it is easy for them to make friends with their resemble gender members first. As a result, when that partygoer feels uncomfortable and decides to leave, it is reasonable to have all of his or her friends to come along.
- As one sub group, either male or female, moves, that group become scattered. In this model, it is assumed that the agents represent open-minded people who are outgoing and eager to find new friends. Thus, it is reasonable to have the other sub group move to look for new friends when one sub group decides to leave. However, due to the shy character of female partygoers, female subgroup can stay and wait for another male subgroup to come forward. In short, if a group is breaking, the remaining boy subgroup would have to move but the remaining girl subgroup can either stay or move unless they are the ones who are uncomfortable.
- If one group in the party is not stable then not only that group has to be changed but at least one other group has to move as well. This rule is necessary in order to avoid the party ends up as a single large group in the end.

Some settings of this game can result in a deadlock. This situation is usually encountered in a big game where there are many partygoers and many greatly unbalanced groups in a simulation. In order to solve this situation, another rule is created.

- Merging two sub groups is allowable. Merging moves, like any normal moves, can only apply on two neighbor groups. In order to avoid one big group as a final result, merging is only allowed every two normal steps.
- No “jump” move is allowed.
- The simulation continues until all groups are happy with their settings.

For example, let a party consists of 32 people (16 boys and 16 girls) gathering into four groups and the tolerance is 40%. The initial set up is (4, 4); (4, 3); (6, 4) and (2, 5) as (boys, girls). An unhappy group is the one that has the number of one gender more than 40% of the number of its opposite gender. In this case, group I, II and III are considered happy while group IV is not because $2 + 2(40\%) = 4.8 < 5$. Therefore, 2 boys in group IV will leave to their next neighbor groups, either III or I, which means group I or III would have to be reconfigured. However, other boy groups, II and III, do not have to move. A simple solution would be:

1. The boys in group IV move to group III and the boys in group III move to group IV.
2. The girl subgroup of group III and IV has option to either stay or move in either direction.
3. If the girls choose to stay then the result would simply be (4, 4); (4, 3); (2, 4) and (6, 5), which is acceptable.
4. If the girls choose to move then one option is to have girls of group IV move to group I and the girl from group I move to group IV. The result now would be (4, 5); (4, 3); (2, 4) and (6, 4), which is acceptable as well.

Figure 11 shows a visual demonstration of the initial set up and the outcome when following step 1, 2 and 3 in that order.

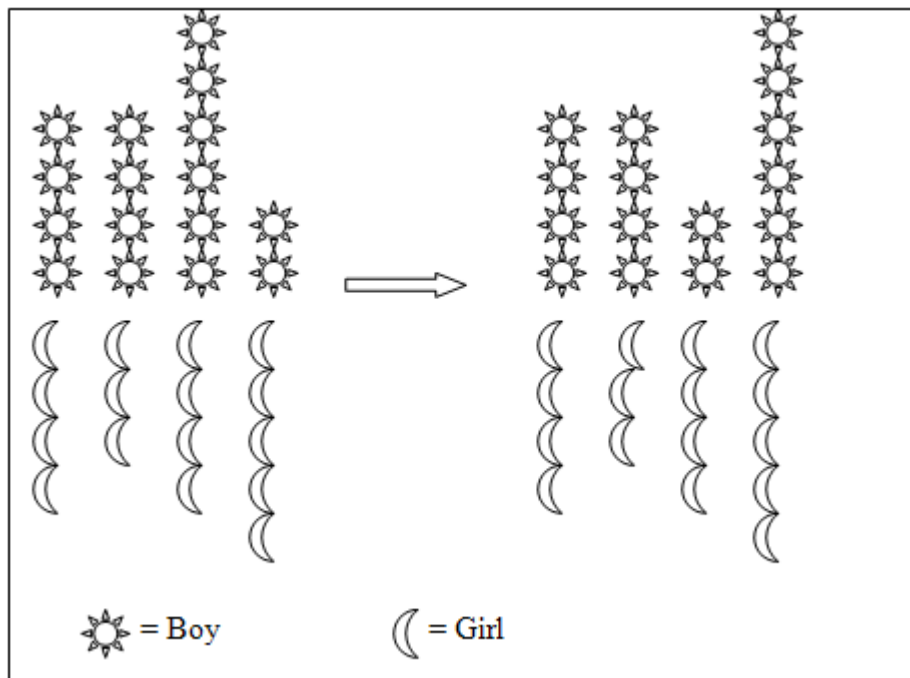

Figure 11: Visual example of Party model

b. “Party” model’s goals

Like many fun and practical models, this prototype provides an intelligence challenge to people who interact with it. However, the model has an ambitious goal. That is to explain the notion that human nature can be modeled with simple rules. Through this accomplishment, one can further help people to avoid or to improve the disfavored outcomes from various situations, in which underlying rules lead to (Resnick and Wilensky n.d.). Specifically, in many simulations, “party” models with moderate tolerance level, higher than 40%, still end up with one gender groups. Yet, it reflects true situations. Many partygoers think that others only prefer interacting with their friends or prefer resemble gender group. Thus, partygoers, with a moderate tolerance level, are unlikely to take action to change the situation. The outcome is that people who would like to enjoy the fun of a well-balanced set up, male and female, end up with a single gender group.

Social scientists can improve this model further such as to simulate the process of how one neighborhood forms. Most neighborhoods consist of many families with at least one common feature. It can be a Mexican neighborhood, where Mexican families are dominant; or it can be Christian neighborhoods, where most people believe in Christian. It is true that cultures and religion are important. They create a person’s value and his or her identity. Culture and religion, therefore, are significant factors that form distinct neighborhoods. However, extreme reactions to personal cultures or religion often lead to discrimination. Based on an improved version of this model, social scientists can find a border line that can both signify the values of culture and religion and allow diversity in a neighborhood. People with different nationalities and different cultures would soon be able to gather in a nice accepting area. Undoubtedly, this goal is one of the first steps required to an ultimate answer to discrimination.

Evidently, there are people who find this model interesting but others find it disturbing. One might argue that people are not dolls! Several reasons that lead people to such strong reactions have been considered. Firstly, people can easily get offended as the following rules conflict with their sense of free thinking. Secondly, a set of independent rules disturb people’s sense as a whole and integrated self. Lastly, they argue that everyone does not have to follow the same rules (Resnick and Wilensky n.d.). These objections are

understandable. It is true that human behaviors cannot be described by a limited set of rules. However, the goal of model is not necessary fully describe a real life phenomenon but to highlight the key ideas of the phenomenon for researches and experiments. In addition, human behaviors are not as complex as many think. In many situations, one usually acts in certain ways that they are taught or prepared. For example, in a fire, panicked victims would simply follow the person in front of them. As a result, agent-based models might not be accurate vehicles that describe human behaviors, but they're proved to be effective methods.

Party hand on doing model

In order to efficiently build the model, the following implicit requirements should be considered.

- The model should be a simple machine that is durable and easy to use since it will provide interactions with patrons of an age range from 8 to 15.
- The model has to be safe to its environment and it should not cause dangerous consequences if it were to break down.
- The model should be economic and affordable. Provided the disfavored state that most museums are in, our goal is to help them get the most return with the least expense.

Meeting those requirements, our final product which is shown in the APPENDIX section were created. Two colored marbles are required to interact with this model. One colored marbles represent female partygoers and another colored marbles represent male partygoers.

The model is basically a wooden box. The box is 68.5 centimeters long, 50 centimeter wide and 10 centimeter high. Each piece of wood is 1 centimeter thick. The box is divided into two sections by the walls in the middle. The wall has 6.5 centimeters wide including the thickness of the piece of wood. In addition to separating the model into two playfields, the space between the walls allows storage for marbles if they are not used. With this structure, two patrons can interact with this model at the same time. There are various reasons for this design. One possible use is to provide a solution of a specific scenario, while leaving the other half of the model for patrons to solve that set up. This method presents a psychological challenge to young patrons to encourage them to solve the puzzle. Another possible use is to allow fun and active

competition to attract young patrons. Two middle-school students can find the model more interesting if they can play with their friends.

Inside each half of the box, I built a waveform curve with an alloy which is a mixture of iron and aluminum to prevent oxidation. The curve is lined up to form four rows. Each row from one end of the box to the separating walls represents one group. The curve is glued fixed into the bottom platform of the box and is able to withstand minor impacts from falling marbles. The waveform shape of the curve ensures the marbles stay in either one of the four groups. Figure 12, Figure 13, and Figure 14 display the technical designs of the model.

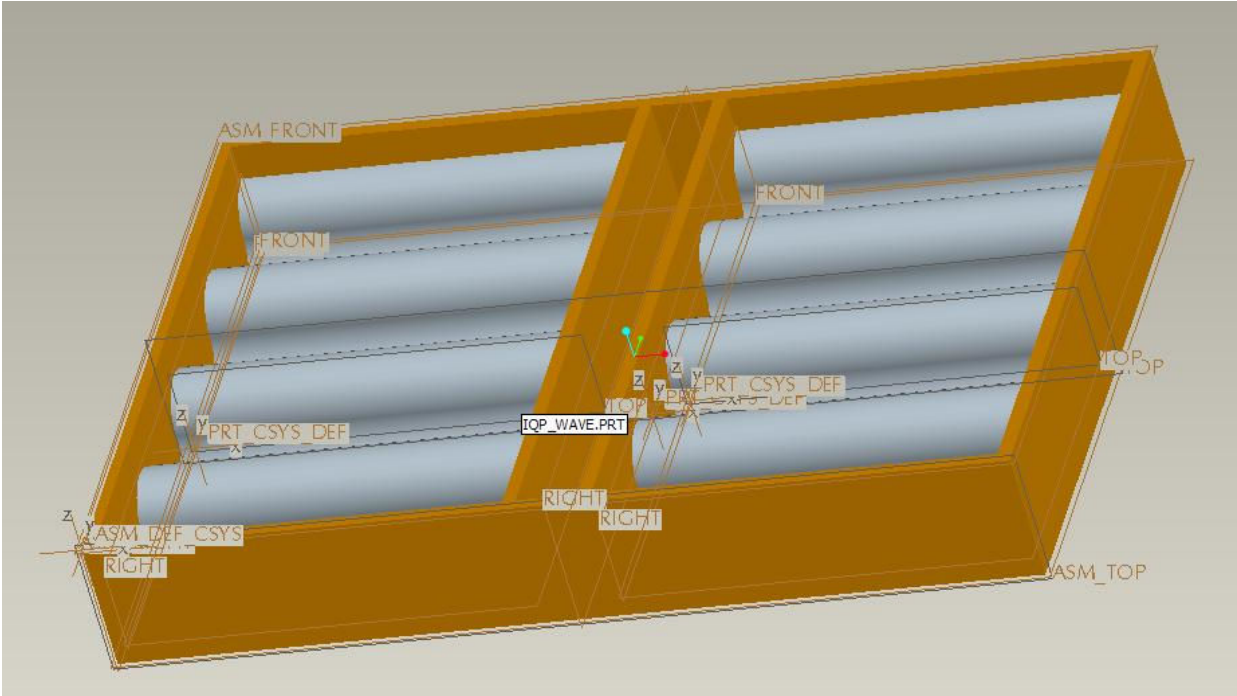

Figure 12: Party Model

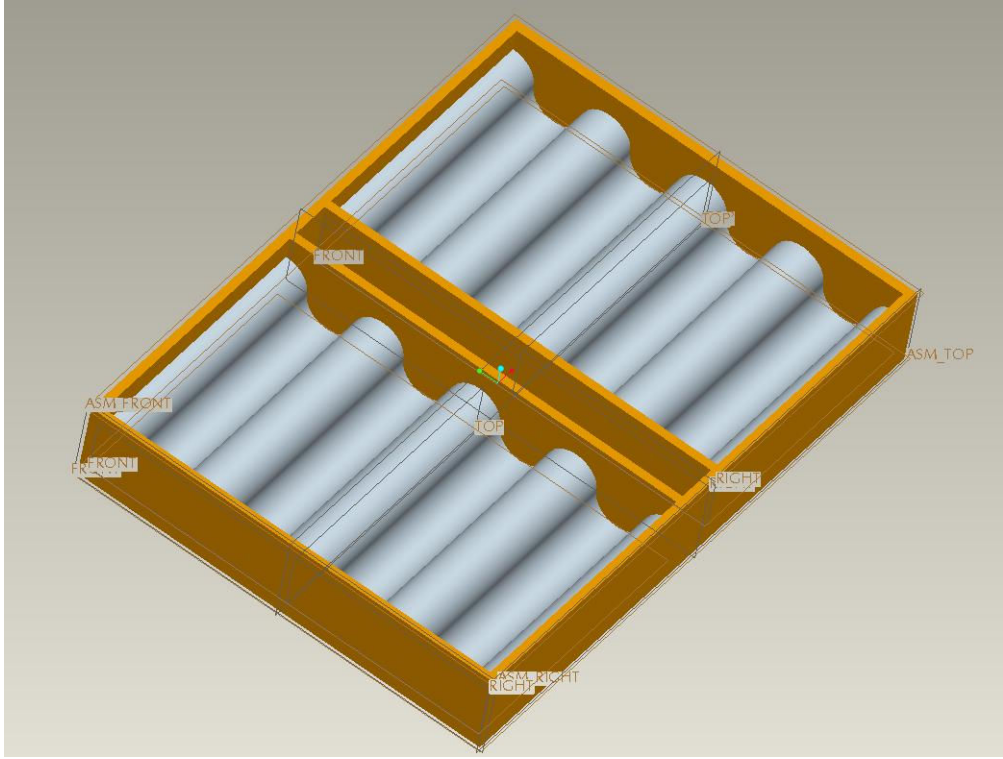

Figure 13: Party model at different angle

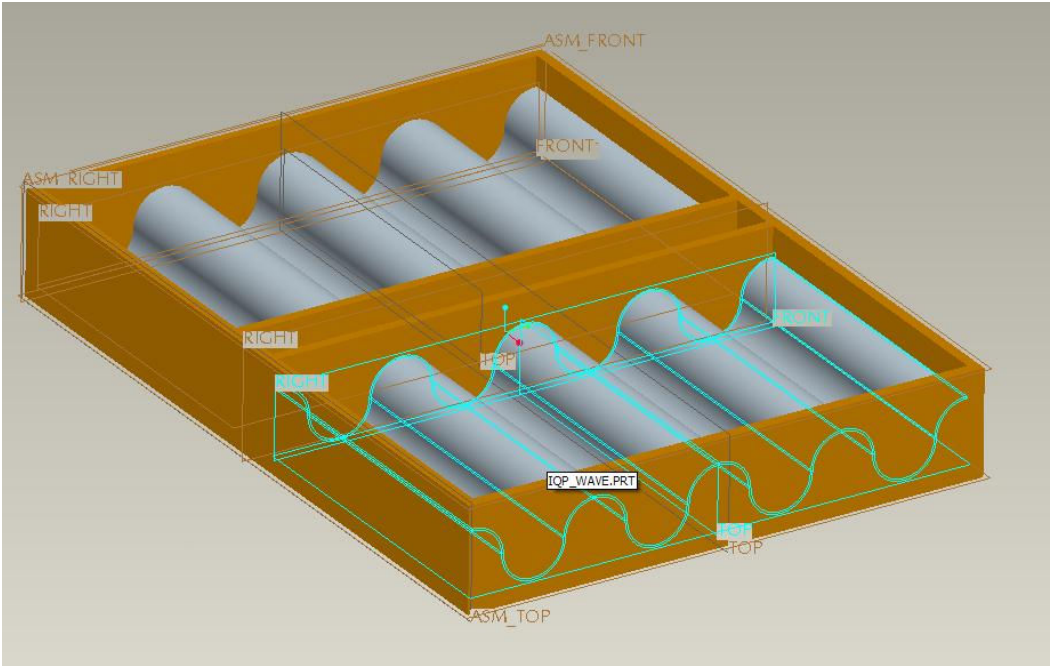

Figure 14: Party model with Aluminum waveform highlighted

Game examples

a. Review and initial settings

This section reviews the rules and provides readers a description of one of the game's settings and some examples of the simulations with this setting.

- Party model has only one modifier that is called “tolerance”. Tolerance defines agents' comfort level. We set tolerance 50% for simplicity.
- This particular model has 4 groups and is set to allow 32 partygoers. There are 16 boys and 16 girls. For easier problems, one can set smaller number of agents. In this example, the male group and the female groups are equal to each other. However, it is not necessary to set a total number of partygoers evenly or divide the number of two genders evenly.
- Four groups are divided into 8 subgroups. Each subgroup represents one gender of a group. For convenience, we will call 4 subgroups for male partygoers: B side; and 4 subgroups for female partygoers: G side.
- If a tolerance exceeds 50%, the subgroup with fewer members, either male or female, will leave the group. It is not necessary to have both subgroups move due to the shy character of the females.
- If a subgroup has to move, it can only move either to the left or to the right neighbor groups, and its corresponding subgroup evidently needs to move in the opposite direction unless it's a merging move. The first and fourth subgroup can move to each of other as if all four groups are lined up in a circle.
- Merging two groups is acceptable but is allowed after every two “normal” moves.
- No “jump” moves are allowed.

Besides these rules, it is helpful to provide customers a table to evaluate “happy” group and “unhappy” group faster. Thus, Table 1 provides the maximum number of people the other subgroup can have provided with a given number of partygoers in a subgroup. The equation to calculate the maximum number of partygoers allowed in the other sub group is:

$$Max_num = given_num + Tolerance \times given_num$$

For example, let a B subgroup have 7 boys and the tolerance is 50%. Thus, the maximum number of girls is allowed in the corresponding G subgroup would be 10.5.

$$Max\ G = 7 + 7 \times 50\% = 10.5$$

Although the result is a non whole number it is acceptable because 10.5 only represent the maximum number of agents. In order words, if the corresponding G group has 10 agents the group is happy but if the G group has 11 girls then that group needs to change. Another advantage of this table is determine how many agents a subgroup should has, on the next step, provided a given number of agents that its corresponding subgroup has. This function would save customers a lot of time from making unnecessary moves and reduce their lost of interest tendency.

| Tolerance = 50% | | | |
|-----------------|-------------|---------------|-------------|
| Number agents | Max allowed | Number agents | Max allowed |
| 1 | 1.5 | 11 | 16.5 |
| 2 | 3 | 12 | 18 |
| 3 | 4.5 | 13 | 19.5 |
| 4 | 6 | 14 | 21 |
| 5 | 7.5 | 15 | 22.5 |
| 6 | 9 | 16 | 24 |
| 7 | 10.5 | 17 | 25.5 |
| 8 | 12 | 18 | 27 |
| 9 | 13.5 | 19 | 28.5 |
| 10 | 15 | 20 | 30 |

Table 1: Agent table - Customer guide to solution

b. Examples

The initial condition of the game is the following. Total agents are 32 people. There are 16 boys and 16 girls; tolerance is 50%. There are 4 groups (8 sub groups). Groups are introduced in this form: (B, G); (B, G); (B, G) and (B, G).

Example 1: Setting is (3, 0); (7, 0); (2, 0) and (4, 8). With this setting, only group IV is unhappy. Thus, the move would be

- $(4, 0); (2, 0); (7, 0); (3, 8) \rightarrow$ Boys from group IV and group I exchange positions. Group IV is still unhappy.
- $(4, 0); (2, 0); (3, 0); (7, 8) \rightarrow$ Boys from group III and group IV exchange positions. Done.

Example 2: Setting is $(1, 6); (7, 3); (4, 2)$ and $(5, 5)$. With this setting, group I, II, and III are unhappy. Thus, the move would be

- $(7, 6); (1, 2); (5, 3); (4, 5) \rightarrow$ Boys of II move to I. Girls of II decided to move to III. Boys of III, thus, have to move to IV
- At this point, no matter how we move the sub groups, they will end up unhappy. Thus, merging move is performed. Girls from III join girls from II, therefore, boys from III move back to IV. Result: $(7, 6); (1, 5); (4, 0); (5, 5)$. However, group II is still unhappy.
- $(7, 6); (4, 5); (1, 0); (5, 5)$. Boys of II replace boys of III. Done.

Example 3: Setting is $(2, 4); (2, 3); (3, 6)$ and $(9, 3)$.

- $(9, 4); (3, 3); (2, 3); (2, 6) \rightarrow$ Girls from IV replace ones in III. Thus, Boys from IV move to I and Boys from III move to II.
- $(2, 4); (3, 3); (2, 3); (9, 6) \rightarrow$ Boys from IV replace ones in I. Group I is still unhappy.
- $(3, 4); (2, 3); (3, 3); (9, 6) \rightarrow$ Boys from I and boys from II exchange positions. Done.

Appendix

The following figures, technical drawings, are designed using ProEngineering software.

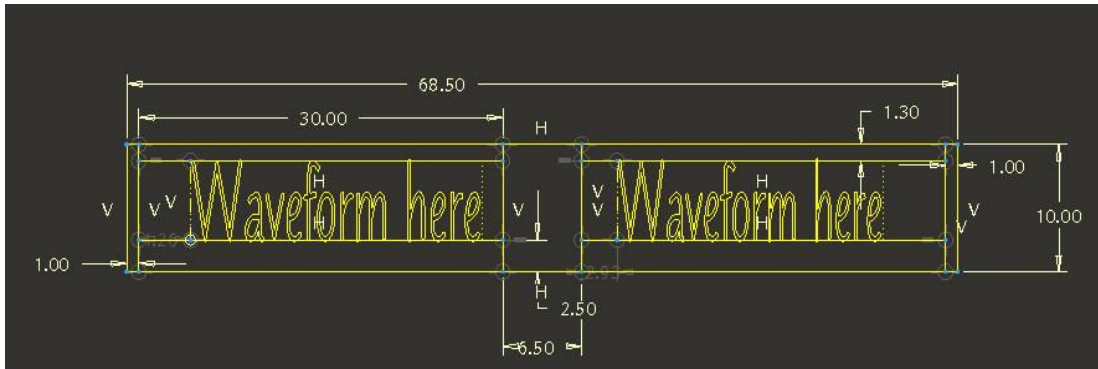

Figure 15: Front view of "Party" model

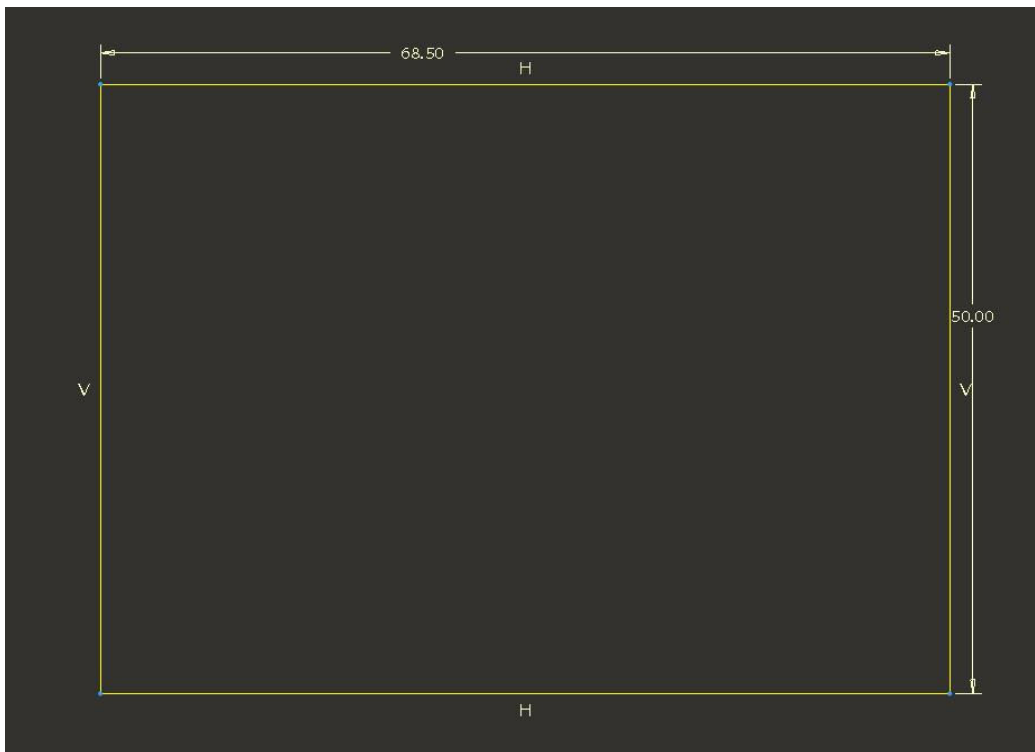

Figure 16: Outer frame parameter

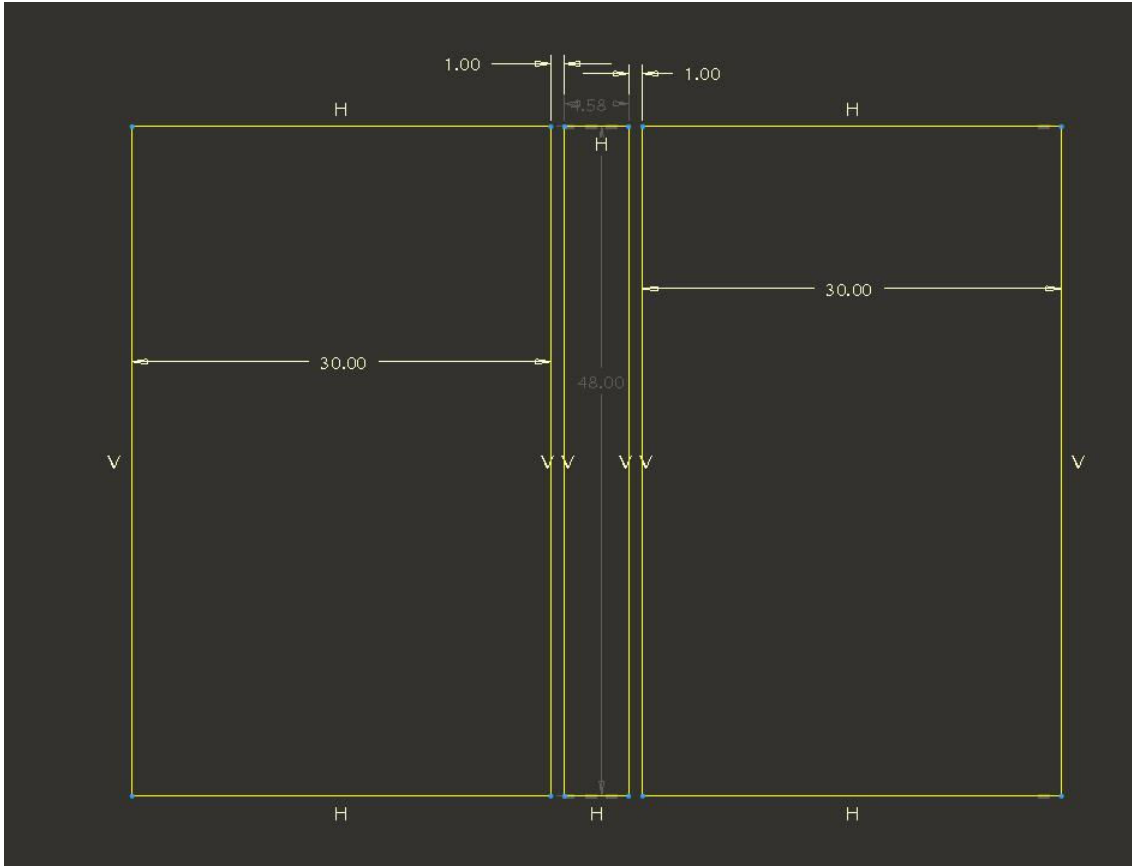

Figure 17: Outer frame detailed parameter (excluding thickness)

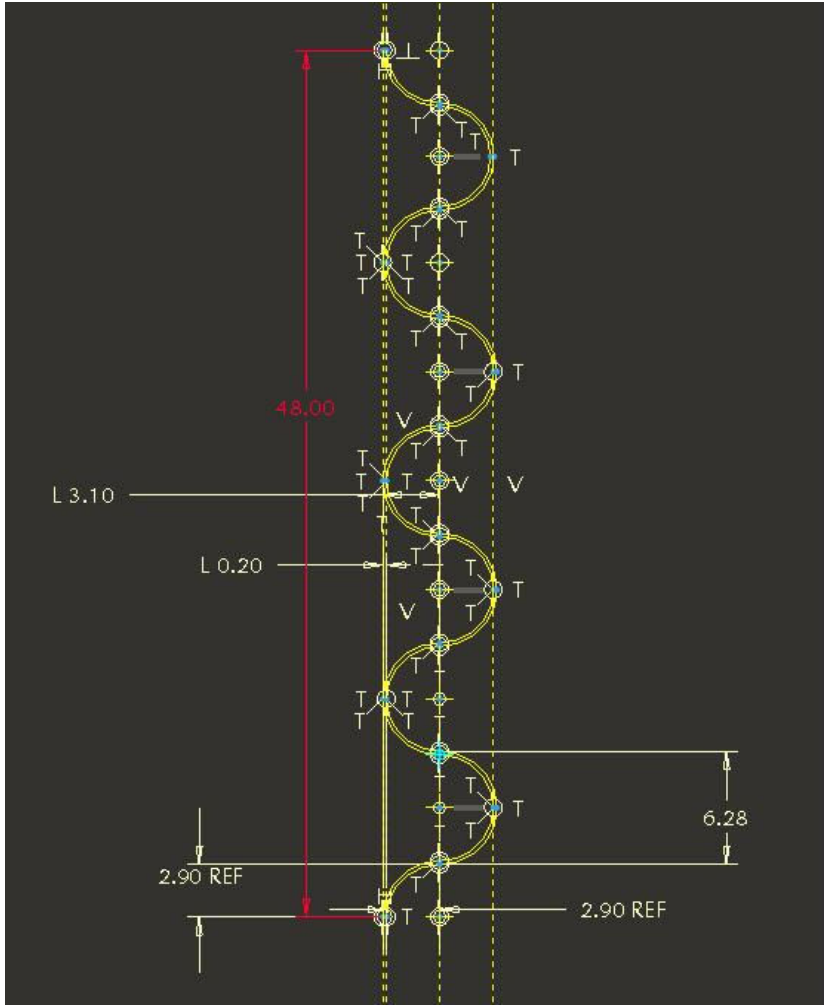

Figure 18: Aluminum Waveform parameter

Bibliography

Bradstreet, T.E. "Teaching introductory Statistics Courses so that Nonstatistician experience statistical reasoning." *The American Statistician* , 1996: 69-78.

Breton, Cape. "Labor Market Review 2004." *Information, Culture and Recreation*. 2004.
<http://www1.servicecanada.gc.ca/en/ns/lmi/Reviews2003/cb2003.shtml> (accessed May 30, 2006).

"Engine of Education." *Learning by Doing*. <http://www.engines4ed.org/hyperbook/nodes/NODE-120-pg.html> (accessed May 28, 2006).

Hasler, Peter, and Neville Mackay. "Visits to museums and galleries." *Competitive market*. 2001.
<http://www.locum-destination.com/pdf/LDR4Visits2museums.pdf> (accessed May 16, 2006).

Holland, J.H. 1996. Echoing emergence: Objectives, rough definitions, and speculations for Echo--class models. in G.A. Cowan, D. Pines and D. Meltzer, eds. *Complexity: Metaphors, Models and Reality*. Addison--Wesley, Reading, MA.

Netlogo Models Library. *Social Science - Sample models - Party*. 1999-2007.
<http://ccl.northwestern.edu/netlogo/models/Party> (accessed May 31, 2006).

Resnick, Mitchel, and Uri Wilensky. *Driving into complexity: Developing probabilistic decentralized thinking through role playing activities*. <http://ccl.northwestern.edu/papers/starpeople/> (accessed June 12, May).

Reynolds Craig. Individual-based model. Oct 1999. <http://www.red3d.com/cwr/ibm.html> (accessed Apr 18, 2008).

Snee, R. D. "What's missing in statistical education?" *The American Statistician* , 1993: 149-154.

The Brooking Institution. "Social Policy." *The Road to Agent based models*.
<http://www.brook.edu/ES/dynamics/models/history.htm> (accessed May 16, 2006).

Wolfram, Stephen. *A new kind of science*. The personal story of the science in this book, 2002.

— . *A new kind of Science*. An outline of basic ideas, 2002.