

March 2011

# A Lunar Base Exhibit Proposal

Ethan Tyler Warner  
*Worcester Polytechnic Institute*

Michael George Sack  
*Worcester Polytechnic Institute*

Paul Stephen Crosby  
*Worcester Polytechnic Institute*

Follow this and additional works at: <https://digitalcommons.wpi.edu/iqp-all>

---

## Repository Citation

Warner, E. T., Sack, M. G., & Crosby, P. S. (2011). *A Lunar Base Exhibit Proposal*. Retrieved from <https://digitalcommons.wpi.edu/iqp-all/1533>

This Unrestricted is brought to you for free and open access by the Interactive Qualifying Projects at Digital WPI. It has been accepted for inclusion in Interactive Qualifying Projects (All Years) by an authorized administrator of Digital WPI. For more information, please contact [digitalwpi@wpi.edu](mailto:digitalwpi@wpi.edu).

A LUNAR BASE EXHIBIT PROPOSAL  
An Interactive Qualifying Project Report  
submitted to the Faculty  
of the  
WORCESTER POLYTECHNIC INSTITUTE  
in partial fulfillment of the requirements for the  
Degree of Bachelor of Science  
by

Ethan Warner

Paul Crosby

Michael Sack

Date: March 15, 2011

Professor John Wilkes, Advisor

This report represents the work of one or more WPI undergraduate students submitted to the faculty as evidence of completion of a degree requirement. WPI routinely publishes these reports on its web site without editorial or peer review.

## Abstract

The goal of this project was to explore the potential in a lunar base exhibit to enhance science education. A Lunar Base (circa 2069) architectural competition sponsored by SHIFTboston provided us the opportunity to examine several promising concepts when the AIAA New England Chapter assigned us to reevaluate 89 entries based on technical feasibility and technological elegance. The results were presented to numerous audiences ranging from aerospace specialists to 5th graders. We persuaded SHIFTboston to run a second architectural competition with a lunar theme- this time focusing on a simulated lunar base as a science exhibit designed for grades 5-10.

## Acknowledgments

Dan Benoit, Architect, Member of Team Goddard

Bruce Mackenzie, Member of Team Goddard

Alessandra Anderson, Artist

Kim Poliquin, Executive Director, SHIFTboston

Dr. Fred Bortz, Author, Distinguished Lecturer

Cecelia Gray, Principal, Midland St School, Worcester MA

## Table of Contents

Abstract .....	2
Acknowledgments .....	3
Table of Contents.....	4
Table of Figures.....	6
Introduction .....	7
The Campaign .....	17
Team Goddard in the SHIFTBoston Contest.....	19
SHIFTBoston Contest Results and Moon Ball 2010 .....	25
SHIFTBoston Judging Process and Criteria .....	30
AIAA Judging Presentations .....	39
Composite Base .....	42
Exhibit Design .....	52
Tying the SHIFTBoston Judging back to the Curriculum Team .....	60
The Midland School Presentations .....	66
Future Momentum .....	69
Conclusion .....	72
Bibliography.....	75
Appendix.....	76
Our Poster Finalists for the Technical Feasibility and Elegance Award .....	76
Origins of the USAF Space Program 1945-1956 .....	87
Chapter 1 - The Beginnings .....	87
Proposal to the City of Worcester.....	91
Introduction .....	91
The Lunar Base Exhibit .....	92
The Competition .....	95
The Ideal Location .....	98
Current Support .....	105
Conclusion.....	106

References .....	109
ORIGINS OF THE USAF SPACE PROGRAM 1945-1956.....	109
Independent Study Project by David Linke .....	113
Entry Rankings & Validation.....	113
Discussion of Results.....	115
Frequency Distributions .....	115
Categories .....	115
Standard Variables .....	115
Compound Variables.....	117
Relationships.....	118
Standard Variables .....	118
Compound Variables.....	120
Technical Feasibility .....	122
Moon Capital Competition 2010.....	122

## Table of Figures

Figure 1 - Lunar sling design concept ..... 20

Figure 2 - Nuclear facility overview ..... 21

Figure 3 - Classroom facility overview ..... 23

Figure 4 - Craterville rendering ..... 24

Figure 5 - Living quarters from Moon Capital ..... 45

Figure 6 - Living quarters from Craterville ..... 45

Figure 7 - Living quarters from L.E.A.P. .... 46

Figure 8 - Moon Capital light reflector ..... 47

Figure 9 - Composite Base depictions ..... 51

Figure 10 - Moon Capital..... 77

Figure 11 - Craterville..... 78

Figure 12 - The Crater Colony ..... 79

Figure 13 - Seed of Life ..... 80

Figure 14 - Moon Capital..... 81

Figure 15 - L.E.A.P. .... 82

Figure 16 - Town Planning Mostyrando ..... 83

Figure 17 - UniverCity ..... 84

Figure 18 - Fort Rille..... 85

Figure 19 - Moonbase ..... 86

## Introduction

The prospect of human settlement of the moon has intrigued mankind since we first looked up at the night sky. For centuries, scientists have studied the moon and tried to figure out what and where it was, and how it affected the Earth. In the 19<sup>th</sup> century and early 20<sup>th</sup> century a serious search to find a way to get there began. Robert Goddard (1882-1945) was one of the three intellectual leaders in this effort along with Konstantin Tsiolkovsky (1857-1935) and Hermann Oberth (1894-1989) trying to figure out how to send a human beyond the reaches of the Earth and to this distant and elusive place, among others. (See Appendix 1)

In 1969, the dream was realized when Neil Armstrong set foot on the lunar surface and inspired a generation with his famous words. After the Apollo 11 mission, five more Apollo missions landed on the moon to make observations and take samples of the foreign terrain. The last manned mission to the moon was Apollo 17, which landed in December 1972. No human has set foot on the lunar surface since.

Recent legislation has shifted the focus of the National Air and Space Administration away from the space policy goal of revisiting the moon by 2020, and away from the opportunity for the United States to renew its reputation as a science and technology leader in this field. Meanwhile, China is seeking to demonstrate its prowess in space exploration. The next lunar landings are expected to be carried out by the China National Space Administration at about the time of the 50th anniversary of the Apollo missions in 2019. Since significant research on the moon has been conducted over the last few decades, we now have a clearer picture than ever of what this environment is like. The next step is to use this knowledge to design, and eventually construct, a semi-permanent lunar settlement. If the dream of a sustainable lunar base is to be realized, there is a need to stimulate a passion for this kind of challenging space science and technology in students at the elementary and middle school levels.



Unfortunately, science and engineering are not considered an interesting or desirable field of study to many young students. In the Massachusetts public school system, there is little emphasis placed on the lunar sciences or astronautics in general. In fact, many students struggle with the more general concepts that the Massachusetts Comprehensive Assessment System (MCAS) set out to evaluate with its new Science and Technology/Engineering section. In 2010, only 53% of students in grades 5, 8, and 10 scored “proficient” or higher on the Science and Technology/Engineering section. (MCAS Results, 2010) Opponents of the MCAS, like Marilyn Segal of Citizens for Public Schools, said the science exam risks turning students off to the subject, short-circuiting the state’s goal of trying to grow a larger workforce in the sciences. “It’s the worst way to teach science,” she said. “Memorizing facts is not learning about science. They should be doing labs. The test was set up to fail a bunch of kids.” (Vaznis, 2009) These test results and widespread disdain towards the MCAS Science and Technology/Engineering section show that students are not familiarized or interested in the subject, and the assessment process is viewed as a negative rather than a fulfilling experience.

In addition to the requirements set forth by the state, students are also limited by a lack of realistic and interactive environments in which they can learn through a hands-on approach. Adam Savage, co-host of the popular Discovery Channel television show “Mythbusters,” emphasized this need for experimentation in a recent interview with Popular Mechanics Magazine. “It’s really difficult to absorb things just by being told about them... If students could get their hands dirty in science class they’d be more likely to internalize information.” (Savage) Since this experimentation in the classroom often requires enormous amounts of resources that are often not available within the school budget, the next best option is to locate these “learning laboratories” in a central location so that classes in a large school system or a few small school systems would be able to visit it regularly on field trips.

In addition to a greater emphasis towards hands-on learning and experimentation, there is a substantial need to bolster the quality and relevance of the current science curriculum using integrated themes that tie topics together. A combination of curriculum reform and more equipment for experimentation would allow for a comprehensive science education experience to emerge. There are two missions for any well-rounded science education. One of these goals is to produce a technologically literate citizenry for a democratic yet technological society that can understand what is called for to preserve the health, safety and prosperity of the Nation. The second is to identify and nurture the next generation to scientists and technologists. Ideally one wants to encourage all students to investigate the benefits of a technical career, and gain the necessary background to pursue that route of higher education if they decide to do so at some point after secondary education. In order to motivate students to learn the sciences, educators need to find something that interests or excites them. Everyone needs to master the basic concepts that will help them relate to issues like global warming, energy production, and nutrition. In order to inspire the minority- a future generation of engineering and science students larger than the current one, an exhibit should be constructed in Worcester that represents a compelling challenge, a new emerging industry and an area in which discoveries are likely.

Worcester is a city with a tradition of technical innovation and the local pioneers later spawned new industries in several fields, most notably steel wire for fences and machines that could fold envelopes. Worcester is also the home of Robert Goddard, the father of modern rocketry. This rich history allows for a strong case to be made for the training of students to take on the challenge of building a permanent outpost in space. This challenge can and will fire the imagination and engage the technically inclined to expand our scientific prowess. This challenge has presented itself before, during the golden era of the 1960's Space Race in America. At that time, the best and brightest gravitated to the space agency and we reached for the stars in a "come from behind" victory over the technocratic Soviet Union. However, this program was halted just when the idea of constructing a lunar base was

coming into view. Instead, efforts were shifted to building several generations of Intercontinental Ballistic Missiles, and away from manned space exploration.

These missiles were sufficient to launch Earth satellites, and were adapted to reach space stations. While useful and often profitable, this kind of space program was not pioneering and not exalting or exciting. The best and brightest of an entire generation turned their attention to computers and telecommunication, and more recently biotechnology. The aerospace community began to age and now 26% of the American experts in this field will reach retirement age in the next 3-5 years.

It is now an area of great opportunity for the next generation, but it is not perceived that way since few major breakthroughs have been made in the field for decades. Young people can barely believe that America once prided itself on being the first nation to put a man on the moon.

The central mission of the science exhibit is to change this perception of space as a dead field and the moon as a desolate place. Younger generations need to learn that this area is on the verge of greatness and the moon is a resource-rich oasis in close proximity to the earth. In space context, that is exactly what it is. While the moon looks barren compared to Earth or even Mars, it offers many resources for scientific and even economic development. While it would be easier to live on Mars than the moon, it is much more difficult to get to Mars and there is nothing there that we need on Earth. Any trip to Mars will be purely for scientific purposes. The moon offers much more in economic terms. A lunar base is the key to developing and supplying stations and depots in near space. It is a strategically important site for a space-faring society.

The central science exhibit should be a place that simulates lunar living where students can explore, envision, and critique the ideas of their predecessors. Visitors would be able to learn how to operate there in an accurate and realistic test bed environment. This exhibit has a unique advantage in teaching general science since the space environment is unfamiliar and different from Earth on a

fundamental level. Visitors will see the Earth with new eyes after learning how to live and work on the moon. The exhibit would combine concepts from a wide variety of science topics with demonstrations. It turns out that a simulated lunar base would be an excellent theme around which to design an interdisciplinary science exhibit.

This exhibit will be a physical representation (visitors can walk through and touch many elements) of current lunar space colony design concepts, and a place to test theories and prototypes. Although fun and excitement are necessary to attract the students' attention, it will also include scientifically accurate depictions of the proposed location and basic layout of the lunar facilities and operations. These exhibit elements would be designed to provoke debate about why and how they work the way they do. The operations to be depicted in detail include, but are not limited to, the gas mining of both Helium-3 and oxygen, which are key elements of a self-sustaining lunar base, and an agricultural village, in which robots and humans co-exist in a new and tightly integrated way. It is a glimpse at a possible future, and not just on the moon. What is envisioned is a base that can feed itself and pay its own way as part of a larger trade system.

Currently in the Worcester public schools, there is a massive falloff of interest in science as students reach high school. About a third of Worcester 8<sup>th</sup> graders, both boys and girls, report that science, math or both are their favorite subjects. By 11<sup>th</sup> grade, when they are preparing to go to college, a career in science is of interest to only 5% of the boys and 5% of the girls. Engineering is of interest to 20% of the boys and 5% of the girls. Thirty percent of the girls and 10% of the boys express interest in a medical career.

Relatively few Worcester students get a serious chance at realizing these aspirations due to low average SAT scores, and that is with only about 60% the students taking the PSAT and SAT tests. Ninety percent of the students in many suburban school districts take these college admission tests. However,

the interest is there in the schools that can provide the foundations needed to pursue these careers. In the United States about 7% of the high school students go on to major in science or technology. The comparable figure in China is 30%. As mentioned above, that is also how many 8<sup>th</sup> graders want to pursue science before chemistry and physics classes are completed in 10<sup>th</sup> and 11<sup>th</sup> grade. These classes and other factors seem to change the image and experience of science.

The challenge is to get at least our top third of science-oriented students ready for that challenge. One has to make the study of these physical sciences as engaging as biology is in middle school and provide a solid foundation to have the average student take these “serious” courses in stride. Then the self-image of having the potential to “do” science will persist into college, where they will meet practicing members of these professions and some actual technologists. A simulated lunar base is a place where knowing physics and chemistry will be so advantageous that it will be absorbed on a “need to know” basis. It may even become the key to full membership in the insider club of “cool” people who are doing special projects (with college student coaches) at the local science center, after school or in lieu of taking certain science or engineering design courses.

It is the current 5<sup>th</sup> graders that would be the first group to experience a space enriched science curriculum. Those students who are around ten years old now will be the ideal astronaut age (about 40) when crews are being picked to go to Mars and to build a permanent lunar base.

This exhibit's main function will be as an interactive lab that ties in with a redeveloped science curriculum for the Worcester Public School system that includes a space unit of about 6 weeks each year (from Grades 5-10) in which the text book is set aside and science becomes thematic and interactive as well as cumulative, building on the activities of the year before. This unit would culminate in a field trip to the exhibit every year, though the subjects, topics, as well as the activities would be different but complementary year to year.

In order to help the students gain basic knowledge of science and engineering background needed for lunar life and work before attending the exhibit, they will learn some of the basics in the classroom. To help accomplish this goal, the exhibit will be designed in collaboration with another project group that will be working on developing a “spiral” curriculum devoted to the study of aerospace in general and living and working on the Moon in particular. This curriculum will change focus moving from a 5<sup>th</sup> grade orientation to lunar conditions that is long on geology to biosphere balance and plant biology (grade 6), basic chemistry (grade 7), physics and astronomy (grade 8), robotics (grade 9) material sciences as they relate to solar and nuclear power production (grade 10), anatomy and physiology (grade 11), systems thinking and engineering design (grade 12).

The curriculum team has been working with 5<sup>th</sup> graders from the Elm Park School in Worcester by both observing them in a classroom setting and trying science class enrichment activities involving not only experiments, but craft activities and model building as well. By documenting the current teaching practices and the response to changes, student engagement and interest in different class activities, and the typical range of academic ability in a class, the curriculum team prepared itself to produce a field trip event with a high probability of succeeding at low cost and a set of lesson plans for a month of non text-based activity leading up to this event. In effect this is a guide on how to prepare students to make the most of both a special speaker and a thematically integrated field trip designed to serve as an MCAS review and a science enrichment event. The curriculum team has come up with approximately 20 hours of lessons, all touching on the subjects contained in about 5 text chapters - but without directly reading the text. The whole unit is equivalent to about half an academic quarter in the 5<sup>th</sup> grade science curriculum. Future curriculum development teams will do something similar for grades 6-10 (at least), moving the program up to the middle and high schools. This will provide a solid background in science and technology more generally and if taken together will be the equivalent of a whole year of space oriented science, taken bit by bit over the years so that it is cumulative and all

thematically integrated. This must be done without detracting from the curriculum topics stressed in the state curriculum frameworks, though it will be to some extent at the expense of the text. Clearly the way forces, matter, energy, electricity (and even the solar system) are being handled at present is a problem. It sets the stage for the crisis in science aspirations when the students hit serious chemistry and physics in 9<sup>th</sup> and 11<sup>th</sup> grade. Maybe we can do better by covering the same topics without using the textbook approach. This is the kind of material for which the study has to be motivated in advance as well as applied at the end and which benefits from a hands-on approach. We think a theme to hang the concepts on will also be helpful.

The 3 pages in the text comparing the moon and Earth are not satisfying for two reasons. One is that it approaches the moon far more in terms of how it looks from Earth rather than what it would be like to physically be there. When it does finally describe the lunar environment it presents it as desolate and a place one could not live, much less thrive, forbidding rather than as a worthy technological challenge that can and will be overcome. The text should not be discouraging students to think big, rather it needs to be motivating children to look beyond what our technology looks like today, and strive to conquer the challenge that is the moon. With our help the curriculum team completely overturned this perception for 400 Worcester students in a single school day. We never challenged the text, especially not the facts presented. However, our lunar base design presentation was the main battering ram and completely reversed both the perspective and the message of the science text in about 30-40 minutes. Of course they did not tell us that that was our job, but in retrospect they used us for exactly that purpose. In return we got to see if a lunar base could engage the majority of the students in this critical age group, and the result of that experiment was particularly gratifying.

Over the course of the project, we worked with and met a few administrators and about 15 teachers from 7 schools in the Worcester Public school system. The head of district science curriculum

coordinator Kathy Berube, and John Monfredo, a member of the school committee also came to see our presentation and seemed impressed by the educational potential in the lunar base theme - especially as represented by the "Craterville" image of a second generation lunar base. The ultimate goal is to expose the students to an interesting and exciting interactive exhibit based on that vision and some other elements taken from the best entries to the lunar base contest. This would solidify what they learned in class with vivid images of what can be done with that information applied to this challenging problem that will be faced by their generation.

In summary, the need for new scientists and engineers will not diminish over the next fifty years. The way to ensure that the best and brightest again turn their attention to aerospace and all the other fields of science and get well prepared recruits from a strong pool of at least 25% of college bound students, is to integrate the science curriculum with an exhibit that can support field trips for every class, every year, without being repetitive. If these positions are filled, it will boost Massachusetts' reputation as a science and technology education leader, and attract high tech companies to the area. This would yield more great jobs, and a thriving local economy. A good school system also means strong property values as people want to live there and work there.

We advocate the adoption of the lunar base theme to enhance the science curriculum in Worcester, the city of Robert Goddard, and initiate the preparation of the generation that will pioneer the idea of living in space, starting with the moon. Enhancing that kind of curriculum is best done by designing and then building a lunar base exhibit that represents the worthy goal of a lunar base designed to grow into a colony and city that that can feed and pay for itself. The teachers are right that it must have an accompanying space-enhanced classroom curriculum that teaches students the basics of space as well as science, but the two in combination would be a powerhouse of stimulation for science education. The curriculum would benefit greatly from encouragement to explore those topics in a



capstone experience that they know is coming in a simulated lunar facility, which can fire the imagination and take you to another world.

Our part of this endeavor was to prove that one theme that would work in this way, and was a good fit for Worcester's history and hopes for the future, would be that of a lunar base. The virtue of this theme is that it can support a multidisciplinary science exhibit and gives one a chance to study the Earth as a biosphere in microcosm. Hence, one can review both Earth and space science concepts at the same time and oddly enough, the moon makes the study of Earth more interesting by systematic comparison. It is odd that to appreciate the Earth you need to examine the moon and Mars, but it is no less true that the destiny of the nation and mankind is in being a pioneering space faring nation.

There has not been an opportunity like this for 500 years, since Europeans found, conquered and developed the "New World" (a.k.a. the Americas) in amazingly fragile vessels as they mastered the art of sea faring. In so doing they changed the balance of wealth and power on Earth from the traditional pattern of having the most advanced civilizations being in Asia and the Middle East rather than Western Europe and North America.

## The Campaign

Over the summer of 2010, the AIAA devised a campaign to try to enhance science education in Worcester by introducing a moon-themed component to the current science curriculum.

Implementation of this plan involved recruiting two teams of WPI students to continue past work in integrating space science concepts into 5<sup>th</sup> grade Worcester education. The first team, the curriculum team, would work directly with students in the Worcester Public Schools to develop a prototype spiral space-enriched science curriculum for elementary school students. The second team, the exhibit team, would take on the ambitious task of designing a lunar base exhibit to parallel and enhance the spiral curriculum. Prior research indicated that without an integrating curriculum the science teachers would not support the exhibit as a preferred field trip for their classes as it would be a distraction rather than an enhancement to their science education. This challenge set the stage for the close collaboration between the Curriculum and Exhibit teams. These teams worked both in collaboration and independently, ultimately towards the same goal of improving science and space education in the local schools system.

The curriculum team consists of three students who visited several Worcester public schools to observe and test students from different grade levels. Their main goal was to use the challenge of living and working in the space environment and the umbrella theme of a future lunar base to exemplify all the concepts covered in the text in a new way. For example, the team developed a hands-on activity to explain what gravity is, and how the gravitational force on the moon differs from that on the Earth. The real challenge, however, is how to cover 4-5 chapters of standard science using Earth examples by providing the moon comparison, in ways that were mutually enhancing.

The exhibit team, which was our project, also set out to teach science in the context of a lunar base, although accomplishing this task was a bit less defined. In the beginning of this campaign, the idea was to design and propose a lunar base exhibit to aid in the education process that was being developed

for the school system by the curriculum team. This plan included researching and selecting a suitable location to build the exhibit. To guide this search, we looked at several different criteria, including central location and costs. Once a building was selected, the blueprints and dimensions of the building would be used to design CAD drawings and models as well as a tabletop model for display. The tabletop model would serve two purposes. Since the model would be an accurate depiction of a lunar base, it could be put on display for students to examine for educational purposes. The tabletop model could also be used to display the concept in a concrete fashion to investors and supporters of the proposal. These detailed plans would then be used to purpose the actual construction of this exhibit in the near future at the decided location, or a comparable one. While these goals seem straightforward and concrete, the direction of the project took many unpredictable, however exciting, turns.

## Team Goddard in the SHIFTBoston Contest

Soon after the AIAA campaign was presented and the student teams formed, a contest was announced during the summer sponsored by SHIFTBoston. Entitled “Moon Capital,” this competition challenged teams from all over the world to design a lunar base to be built near the year 2069. These lunar base designs were to be judged in one of two main categories: architectural and artistic (“Let’s Have Fun”), and technical feasibility and elegance (“Let’s Get Serious”). Immediately, the exhibit team took interest in this contest, for the potential it had to generate ideas for the lunar base exhibit. At the start of the academic year, our group was invited to participate on a local team named “Team Goddard.” The team consisted of several WPI community members as well as other local architects, artists, and scientists. The exhibit team immediately began to take on responsibilities within the team in order to meet the fast-approaching entry deadline. These responsibilities included designing a lunar tether to sling exports off the moon efficiently, a medical and educational facility, and a comprehensive nuclear power generation complex.

The lunar surface sling (based on the idea of a space tether) was a very creative and ingenious design, even though it was still purely theoretical. The concept behind the proposed device was the use of centripetal force from an enormous (8 km) sling that would reach escape velocity of 1.4 km/s, launch and throw moderate (5 ton) payloads off the lunar surface and into lunar orbit. This mechanism would be very valuable, because it would obsolete the need for rockets and rocket fuel to lift freight off of the lunar surface. This is elegant since the freight would be liquid oxygen, which is a critical part of any rocket fuel system. It is like avoiding the use of gasoline to deliver gasoline to Denver, a city high in the mountains. The vehicles that would complete the process of taking the fuel from lunar orbit to Earth orbit, if ever built, would be an enormous feat of engineering, but in a way that part is not needed. Just the 8 kilometer radius sling on a lunar mountaintop would outdo any Earth-based competition to refuel rocket fuel depots. Earth would not have a chance of competing with the use of a nuclear-powered sling

putting 5-ton payloads to lunar orbit. The tether/sling system would also have the ability to “catch” incoming payloads and safely slow them down and transfer them to the moon’s surface, but that has less economic significance. The Earth would have to build a space elevator to start to be competitive with the cost of bulk supplies delivered by this system. The materials used in the construction of the lunar tether were also cheap as they were scavenged from used descent engine and fuel tanks. This was no doubt an ambitious idea but also very valuable to the economics and elegant functionality of the Craterville base design.

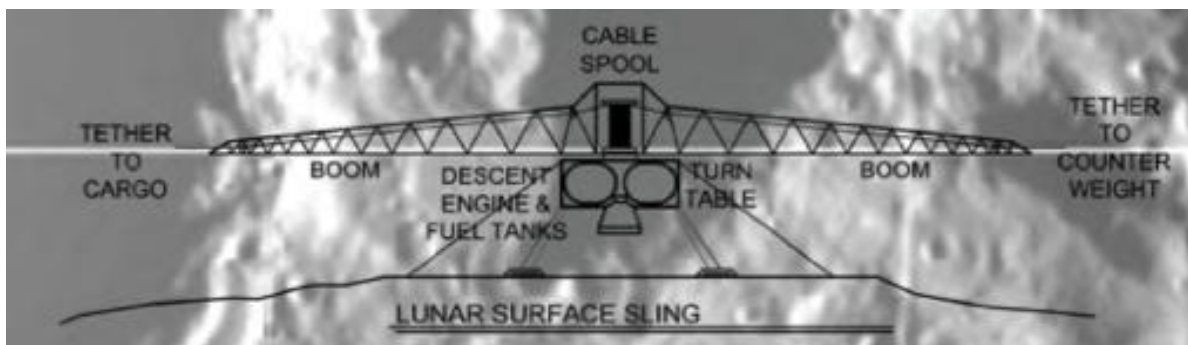

Figure 1 - Lunar sling design concept

The nuclear facility depiction, another contribution from our project to Team Goddard, consisted of a fusion reactor and two fission reactors. The first fission reactor would be used for most of the electrical energy needs, at least initially, of the lunar base. The second would be used to power the lunar surface sling. In addition, the fusion reactor research facility would be used for researching how to use helium-3 as nuclear fuel. This fusion reactor would be powered up by the first fission reactor which would co-exist with it in a facility near, but not in, the plant, removed from the human habitat of the base. This fusion reactor would prove to be useful once the system was fully developed and the fission unit would be used only to power up the fusion unit if it was ever shut down. Initially however, the plan was to use this research facility to push along the helium-3 fusion technology and to prove the concept

of using helium-3 as a fuel. Once nuclear fusion energy production becomes reality, fusion reactors were built for use on Earth would be a bonanza on the moon as a gold rush atmosphere set in to fuel the Earth's energy appetite with minimal ecological impact. At that point the lunar base would not only be able to pay for itself but would be a profitable enterprise. The valuable export from the moon would then be helium-3 going directly to Earth rather than liquid oxygen going to low Earth orbit. These facilities were designed to aid in the safety and functionality of the base as well, and in the long run a necessarily energy intensive lunar civilization would need to rely on the local fuel source rather than just solar energy. In addition to the remote nuclear reactors, a cable car system was also designed to transport the base crew members to and from work at the reactor research lab a few kilometers from the core of the base. The idea was to avoid the need to dawn a space suit and "go outside" by having this car be part of both of two separate air lock systems one was traveling between. A suit would be available in the cable car, in case of emergency, but one would not have to wear it in the pressurized cabin. During this trip, the view in and across the crater on this trip would be spectacular.

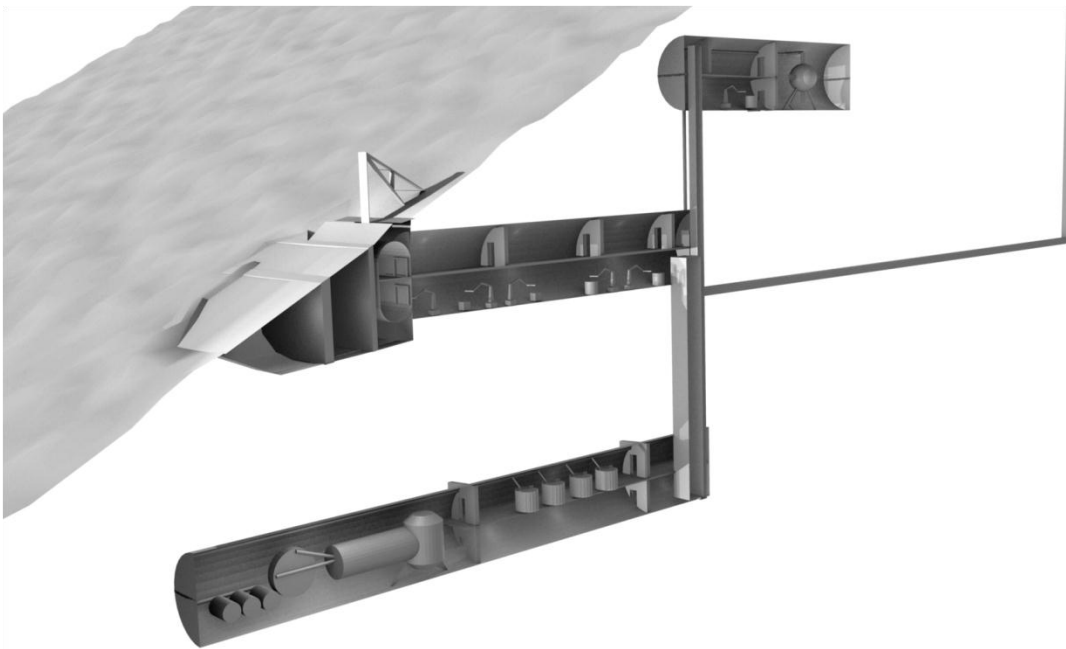

Figure 2 - Nuclear facility overview

Our project group also drew up the design of the educational and medical facilities from oral descriptions provided to us. This was our final depiction contribution to Team Goddard. This connected facility included several major components: a classroom, a zoo, a veterinary medicine section, a medical section, a lunar surface testing room, and an agricultural lab. The space was efficiently used for multiple purposes. The classroom would be built with the zoo nearly surrounding it on one side, with greenhouses for plants on the other side. Both plant and animal studies would be integrated into the curriculum and the teacher in space would double as an animal researcher researching the effects of long-term deployments on the moon and births on the moon in low gravity. Whether there would be children coming with family units would depend on the outcome of these experiments. In either case, children on Earth would have a robotic presence in the school and would use it to help out with the animals that they would treat as pets.

Within the classroom would be two-way video-enabled “desks” that could be used to allow students on Earth to virtually learn on the moon. These desks would be robot stations and the robots would be mobile, giving the students on Earth the freedom to roam around the base and lunar surface, all while being educated about lunar conditions and remote robot operation from the safety and comfort of Earth.

The medical facility is built adjacent to the classroom, zoo, and veterinary rooms. An advantage of this design is in case of emergencies, resources and rooms can be shared. The rooms in the medical part of this design were large for a lunar base, however, the area needed to stay compact to make transportation distances short during time sensitive situations. It was also clear to us that if the emergency medical facilities were contaminated or damaged with a breach of containment, the back-up plan (redundancy) would have to be to operate in the kitchen or a veterinarian hospital unit and we preferred the latter.

Lastly, the surface testing room and the agricultural labs were placed perpendicular to the other sections, running along the long hallway connecting all the facilities. This gave each a long slender room, ideal for growing plants in large experimental beds for the agricultural labs, and good for testing small vehicles and robots on a lunar surface track. All in all, the space used in setting up these facilities was utilized in a very efficient manner, something that is very important on the moon. We were proud of this contribution to the Team Goddard effort, and certainly planned to use the same ideas in our composite base concept for the proposed exhibit.

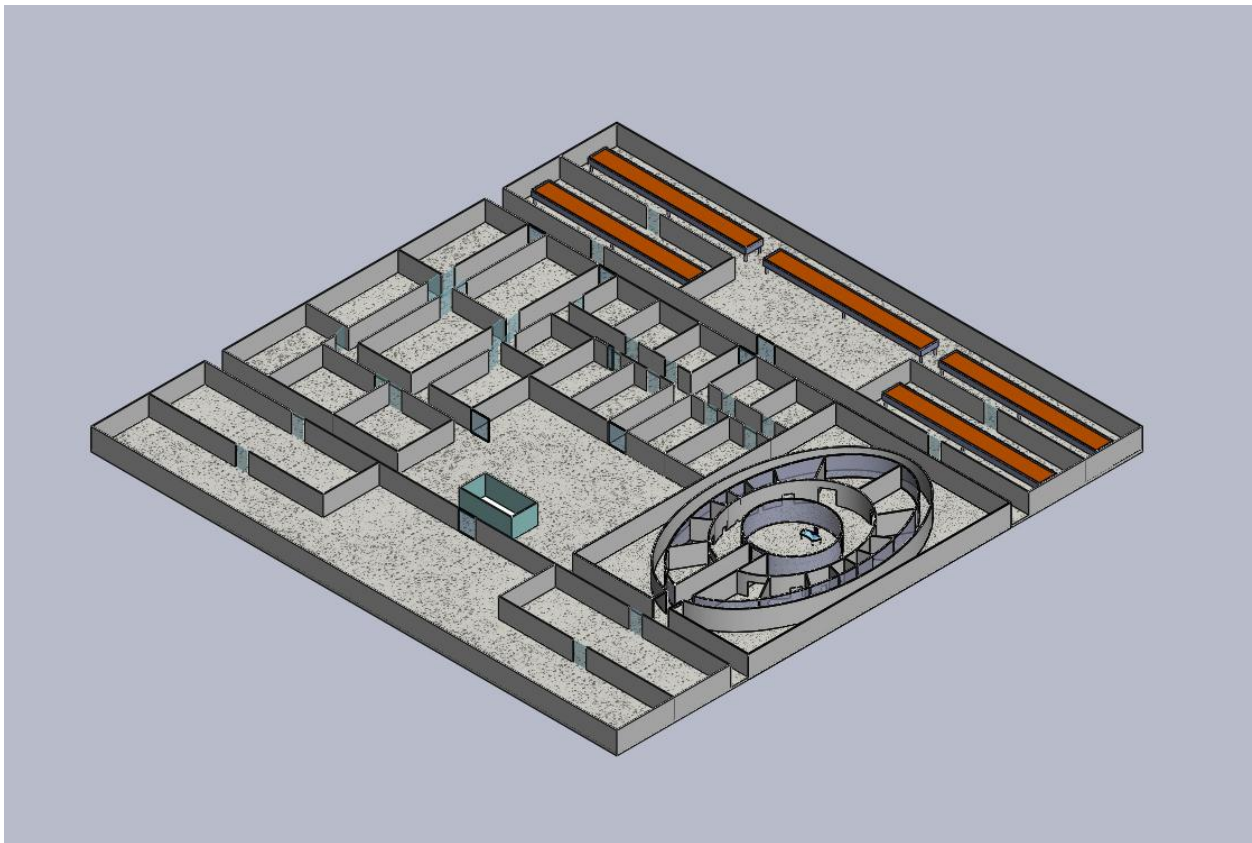

Figure 3 - Classroom facility overview

In addition to the main contributions just mentioned, it was a goal of our project to also help improve the quality of the images for the Team Goddard poster entry. Unfortunately, because of time



constraints associated with the contest, many of the planned images and renderings for Craterville never made it onto the competition poster. However, we still felt it was necessary to continue to work towards a better image of the base as seen from a few different angles to use for our own purposes, and especially to have a deeper visual impact on the viewers we cared most about. These were the 5<sup>th</sup> graders who were not going to read the fine print. They would take in a first impression with a glance and the imagery had to be arresting for that audience. Our project group worked closely with Alessandra Anderson, an Interactive Media and Game Development major at WPI. Alessandra was experienced with producing highly detailed renderings on the computer of complex scenes and buildings. She did an amazing job with helping us produce a very detailed and aesthetically pleasing image of Craterville. In order to achieve the final image, some preliminary sketches and ideas were drawn out and then Alessandra created some initial computer graphics for us to look over. Comments and edits were discussed, and after several revising processes, the final image was produced, shown below.

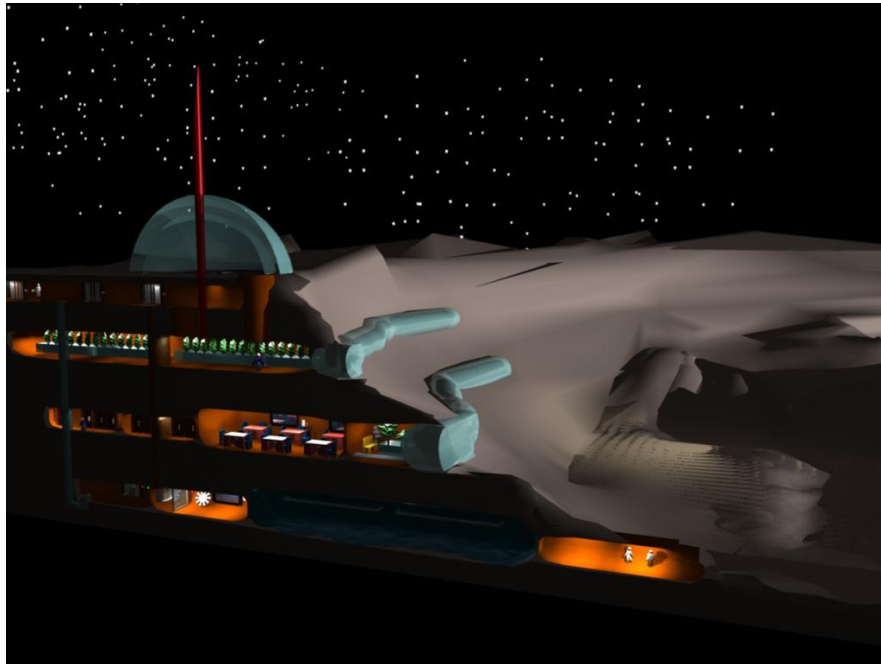

Figure 4 - Craterville rendering

## **SHIFTBoston Contest Results and Moon Ball 2010**

In the middle of October, our group traveled to Boston to see the finalists selected by the judges recruited by SHIFTBoston. This awards presentation night and the associated social event was called Moon Ball 2010, and was held at the historic Cyclorama at the Boston Center for the Arts. To this event, our group brought the Moonraker robot, as well as an informational display to accompany it. We also had a small table with information related to the AIAA New England, and literature describing our project and the role that the competition played in it.

No one was allowed to set up a table or exhibit along the walls and the room was darkened. Hence, we thought that many if not all of the entries would be displayed on the walls and one could walk around the nearly circular hall to see them. This building was constructed in the 19<sup>th</sup> century to display a massive wraparound mural of the battle of Gettysburg in the Civil War, so this is what it was designed for). To our surprise, long cloth gauzy hangings came down to light sources in the middle of the room that projected images up onto the white cloth, and Moonraker was to be in the middle of the room essentially under one set that would not have a light source. However, it was too dark to read the poster, and the information table would be 30 feet away. The cloth decorations made it difficult to get a good look at the robot as well.

Also troublesome was that images were being projected on the cloth but they were nearly impossible to see, and the images were merely decorative, themed video clips. You could not see any details. Hence, everyone had to wait for the formal program to start in a small room to the side with a standard projector supporting it. When nearly all of the guests were packed in this room we finally got to see at least some of the entries after preliminary presentations and the winner announcement. Several of the judges and special guests gave short presentations. These presenters included:

Constance Adams, a National Geographic Emerging Explorer, space architect and Human Factors Engineer at the Johnson Space Center, who explained how we can learn from spaceflight to live on the Earth as well as the Moon and Mars.

Dr. Marc Cohen, a registered architect and leader in the design of aerospace living and working environments including: space habitats, space stations, lunar and planetary bases, who explained how we will live on the moon and the necessary components of the future lunar habitat.

Dr. Jeff Hoffman, former NASA astronaut and current professor of aeronautics and astronautics at MIT, who explained why we will be living on the moon someday as well as sharing some of his experience in spaceflight.

Following these presentations, the judging panel announced their picks for the winners of the Moon Capital Competition. As part of the award ceremony, the finalists were displayed and the judges presented their comments. After seeing all the finalists and the overall winner, our group came away rather disappointed. Although the finalists had beautifully rendered graphics and some interesting concepts, it seemed peculiar to us that a finalist could have a comment from the judges such as, “an innovative idea, unfortunately it would not work on the moon”. This was particularly frustrating since they had not awarded the promised “technical feasibility and elegance award” or shown the “let’s get serious” entries separately from the “let’s have fun” entries. We knew that there was at least one entry out of the 100 or so that would work on the moon, *Craterville* from Team Goddard.

After leaving the contest dissatisfied, we learned that the AIAA New England Chapter, which had put up \$1,000 as a prize for the winner, was far unhappier with the outcome. In the following days the AIAA expressed its disappointment, as they felt their money was not used appropriately due to the lack of technical judging they had promised the regional AIAA when they requested the money. Their money had been used for the overall prize and this was not what they expected when they agreed to fund the

“technical feasibility” prize. The winning poster was not feasible or even possible from an engineering standpoint. It was inspired by a serious scientific proposal, but was not executed in a fashion that avoided internal contradictions.

In response to their complaints, the AIAA New England was told that the money for the second prize was used to fund the awards event, and so there was only one prize. They also mentioned that there were very few technically sound entries and it would not have been acceptable to disqualify 80% of the entries in the ‘let’s have fun’ category from a prize of any kind for a lack of feasibility. The architects valued creativity over technical workability, so half the judges saw this as an art competition and any reference to doing some “science homework” satisfied them. The AIAA was unhappy and a bit embarrassed by the lack of appreciation for technical realism and scientific accuracy. Up to this point, however, the press coverage and the response from the public was positive. Consequently, the AIAA New England left the issue, but asked for access to the full file of entries to see how technically literate the competition community of architects was, for future reference.

This problem was also a setback for our team which had been glad to support the competition since it would expose us to a lot of ideas about how to design a lunar base. The “let’s have fun” entries were less likely to interest us but the contenders for the technical feasibility prize had been of interest. We were hoping to learn from these entries in terms of the scientific and engineering concepts. Although there were probably some good entries in the engineering category in addition to Craterville, they had not been considered finalists by the judges. Further, we now know that there were far fewer legitimate entries than originally expected.

SHIFTBoston soon encountered problems as well, when an article about the Moon Capital Competition and the Moon Ball was published by Scientific American. Readers from across the globe criticized the results in the online forum. Many of the commenters shared the same discontents

expressed by our group and the AIAA New England chapter's council regarding the judging results. It was this negative response that prompted SHIFTBoston to rethink its judging process. SHIFTBoston was preparing a display of the contest and the winners to be exhibited at Johnson Space Center in Houston, Texas, as well as at the American Institute of Architects National Headquarters in Washington, D.C.. With this sort of exposure, SHIFTBoston was sure to receive more negative press if there was not a technical prize winner to accompany the architectural prize winner.

The AIAA New England was watching and saw the Scientific America incident as the last straw. They decided to put up another \$1,000 for a technical feasibility and elegance award, and re-judge the entries based on science and engineering criteria. The AIAA contacted Kim Poliquin, executive director of SHIFTBoston, and let them know of its decision. She was amenable and agreed to cooperate. Since two AIAA council members had been core members of Team Goddard, they knew there was at least one entry that would quiet criticism but they obviously could not appoint themselves as a judging panel.

The council turned to us as an available group of outsiders that already knew the rules and goals of contest, was interested in the technical side of the entries, and could put serious time into the effort since we were getting 3 courses of credit each for the project. One of those courses worth would be devoted to this task. It would benefit our larger project to expose all the sound technical ideas in the pool of about 100 entries. We agreed that it was a win-win situation and accepted the idea that another student was going to do a second review totally separate from ours "to keep us honest".

David Linke would do an independent study project (also a one course effort) going over the same entries, and since he was completely impartial having had nothing to do with Team Goddard, his vote would matter as much as our team vote of 3 people. We were more knowledgeable because we had been involved peripherally at the end, but that was a potential source of bias. However, we were not concerned about that. Since we had also been openly critical of the Team Goddard artwork, we had

an open mind and went into this thinking there must be a better entry. All that would be required of an entry would be a better depiction of a comparable technical idea. Now we would be reading all the details on all the entries and take the whole vision of each depiction into account, but we wanted the art and the text to be balanced and in sync. The artwork was as important to us as the text and that probably was not good news for Team Goddard which was in the bottom half of entries in terms of striking presentation. They had been hampered by not thinking of the base as just the human habitat. They had developed complementary facilities strewn over a 30 km stretch of the lunar surface around a half dozen landing sites certified by NASA near Shackleton crater. Their poster was a mosaic without a clear focal point, and some of the facilities depicted (fuel depot) were actually going to be in space, not on the ground. The vision had not jelled as a picture- but we would now see if the text, which we had not seen before, compensated for that.

The reassignment of our team from designing a simulated lunar base exhibit to developing new criteria and judging the poster entries seemed like a setback at the time. However, we were glad to help out our sponsor and maybe, just maybe, we would find a gem or learn something important.

## SHIFTBoston Judging Process and Criteria

As noted above, the course of our project was adjusted after the Moon Ball and other reactions to the first round of judging. Our group had taken on the responsibility and challenge of re-judging the entries based on a technical feasibility standard. This standard would have to be rigorous enough to restore the credibility of the competition in the eyes of Scientific American readers and hold water in the part of the scientific community that would see the exhibits headed for Johnson Space Center and in Texas and Washington DC. We were told that the Texas display would be going on tour around the state- and not just to artsy audiences. We decided that under the circumstances we would have to be ruthless and dismiss all but possibly one of the original finalists. We would be surfacing a whole new set of 6 finalists from the same pool of entries.

In making this decision we speculated as to what could possibly have been going through the minds of the technical side of the original judging panel when this first group was selected. Rumor had it that the panel had had difficulty coming to consensus. We also recalled that when we met them and heard their comments that none of them seemed enthusiastic about the idea of a lunar base. They had all seemed to want to talk about how special and precious the Earth was and how it would be difficult to live on the moon compared to Mars. There seemed to be interest in the idea of space colonization in general but not in the case that one could make for a lunar base that was economically or technically feasible.

This had seemed odd to us at the time, but now its full implications began to dawn on us. It was the space science community that had mobilized to stop the NASA plan called Constellation to return to the moon by 2020 and formed the Augustine commission to make the case that NASA could not afford to do what it wanted to do with the budget it had. This group advocated going directly to Mars and be first to get there – rejecting the NASA position that the moon as a key step stone into space. Being outsiders to the space technology community, the SHIFTBoston architects had no idea that they had

assembled an expert panel that was indifferent about the goal they had set for the contest. They were assuming that everyone in the space science community was excited by all the new evidence of water on the moon and that that made a lunar base more likely. While that is true, the technical wing of the original jury was opposed to a moon-focused space policy and thus had not stoutly defended the significance of the designs that were workable rather than creative, and specific to a particular location on the moon as opposed to being interesting means to put a base on any other planet.

We would be the first set of reviewers excited about the idea of the economic and scientific potential in a lunar base and attentive to which teams had done their homework on location, and site-specific considerations and the use of available local resources. We were less sympathetic to entries that viewed the moon as a blank slate upon which anything could be drawn. So this was going to be a radical shift compared to the previous judging, but we considered it necessary if SHIFTBoston's reputation in the technical community was to be restored. This judging process also presented a distinct advantage for our project, in that the information and conceptual ideas gained from it would be an enormous help in developing an exhibit design.

The main problem we faced in translation from the architectural designs to an exhibit was that these were second generation bases- ones that could grow into a lunar colony. They assumed a first generation base built in the period 2020-2040 that made it possible to process local materials on the moon to be used for construction. The technical community had been focused on that first generation, minimalistic base. By comparison these looked so lavish and elaborate, that we wondered if they would seem unrealistic to people familiar with the harsh economic and political realities that challenge the idea of a first generation base.

In trying to keep down the cost, the technical community had discounted the aesthetics and focused almost exclusively on what would work. As a result, they had produced nothing inspiring or



even inviting as a place to live on the moon. These designs had shock value in that context, and we decided that that was probably a good thing. It was better to design the first generation base knowing what it was supposed to support as the final goal than to try to design something that would serve many interests but do nothing well.

Over the next couple of weeks, we analyzed each of the poster entries we received from SHIFTBoston, 89 in total. We never got a clear answer as to why 13 of the 102 were not able to be sent to us. The results of our first pass of judging were 17 design concepts that had enough technical substance to be considered a finalist. From there, we reevaluated each of the 17 and narrowed it down to a top ten. At this point we would compare notes with David Linke (doing a separate and independent review) and consult with a few experts in the field that had nothing to do with AIAA New England or SHIFTBoston, totally fresh eyes from other parts of the country. The last step in the process was to rank order the top ten finalists, and to present the proposed winners to the AIAA New England and SHIFTBoston.

Since a technical feasibility and elegance award and cash prize would be presented to the winner of this review process, it was important to establish a solid set of criteria by which to grade each design. We decided upon four main concepts to look for in each base design: quality of life and safety, energy production and usage, base construction process and materials, and function or purpose of the base which could include the economic case for its construction. The yield could be scientific or profit but it had to promise to be worth doing in terms of some kind of payoff.

A grade for each category would be given for each entry, as well as recorded comments, to aid in the quantitative analysis and ranking of the entries. These core criteria, described in more detail below, cover most of the major challenges that a lunar base would encounter. We felt that successful completion of all four of the concepts was vital for each base design to be technically feasible. It is

obvious that any entry, which ignored living and safety, energy production and usage, construction, or economics, would not have a complete lunar base design.

1. *Living and Safety:* How was the quality of life and safety of the inhabitants?
  - a. How large were the living spaces?
  - b. What type of food would be provided?
  - c. What measures were taken to protect against radiation, the vacuum of space, and other safety concerns?
  - d. Was there a way for the inhabitants to gain exercise, entertainment, or education?
  - e. What work would they be doing on the moon and what would their daily schedule be?
  - f. Ultimately, what would the inhabitants be giving up while living on the moon?
  
2. *Energy Use and Production:* How will the base create and use energy?
  - a. What processes were used to produce the required power for the base?
  - b. Were the resources on the moon being used to their full extent?
  - c. Was the energy produced being used in an efficient way?
  - d. Was anything being wasted such as water or food?
  - e. How was light being used and transferred throughout the base?
  - f. How was water being produced and used?
  
3. *Base Construction:* How was the lunar base planned on being constructed?
  - a. What materials was the base made out of?
  - b. Was there a plan for the construction process?
  - c. How long would it take for the base to be constructed?
  - d. What was the modularity and expandability of the base?
  - e. Who was constructing the base? Humans? Robots?
  - f. How would the base be maintained throughout its life?
  
4. *Economics:* Is there a plan to obtain funding for the base?

- a. Where would the money to ship up materials and inhabitants come from?
- b. Does the base eventually pay for itself and become sustainable or is it a research facility paid for by grants and contracts ?
- c. Was cost taken into consideration for obtaining resources and constructing the base?
- d. Are the yields, exports and imports of the base described?
- e. Was cost mentioned at all within the base design?

After establishing the core set of criteria to judge the entries by, we worked through all the posters by deciding upon a grade, from A to F, that they would receive for each major focus concept. Receiving an “A” would mean that a complete solution to the problem was found, and it could be fully implemented without any issues. For example, Carterville was graded an A for economic feasibility because their design included a plan for economic viability through trade primarily through exporting liquid oxygen and later helium-3 assuming that the research program on fusion reactors fostered by the reactor facility was a success. On the other end of the spectrum, an “F” indicated that the poster had no mention of a solution to any of the four major challenges behind or evaluation criteria s, or that the solution(s) presented were not technically grounded.

We saw some with absolutely no technical backing. Others seemed to have a literature source but were widely optimistic about what would be possible in 60 years. For example, we were skeptical about the size and power of a force field that we were told would be generated to protect a base built on the lunar surface on the side of a small mountain in 2069. Somehow solar power hitting the mountain-based solar collectors through that same force field was going to suffice to power the whole system. We are not adverse to someone claiming that a breakthrough in technology is likely, but the whole plan relied on it, and there was no backup system. This results in a lower mark on the technical feasibility front, which places a premium on conservative and robust engineering design.

The grading process was initially used to narrow down our top entries from 89 designs to 17, and candidly, that round of review was not too difficult. The “let’s have fun” entries often had no technical substance, and we were essentially focusing on the “let’s get serious” group that tried to follow the rules laid out by Marc Cohen and had read the specifications. Many were not complete bases by the “serious” criteria and certainly were not designed for 60 people who would eat fresh produce twice a week. After these top 17 were established, the grading system was refined and the remaining entries were scrutinized in greater detail and with more demanding requirements.

We also sent out the list of 17 credible entries to three outside reviewers: Edward Kiker, General Engineer for the Office of the Chief Scientist, Operational Support Office for the US Army Space and Missile Defense Command/Army Forces Strategic Command in Colorado Springs, Colorado, Sherry Bell, Assistant Secretary of the National Space Society, and Randa Milliron, CEO/Founder Interorbital Systems and Trans Lunar Research. Kiker is of interest since he decided to train himself to be the US Army Corps of Engineers commander of the first US lunar base around 1985. He has represented the US at several space conferences trying to assess the implications of the discovery of helium-3 on the moon. Sherry Bell is one of the few space experts that thinks about a base from a psychological perspective, as a place for humans to live, thrive and procreate. Randa Millirone has been thinking about the moon from a business perspective for some time and is well grounded in the challenges of living and working there.

A top 10 ten list was determined and formatted into presentation form, so that our judging results could be shared with relevant audiences in the future. The top 10 posters each addressed all the major four elements mentioned previously, and we feel strongly that each design could be made feasible by the year 2060. A few underestimated a problem, but we could see how that design flaw could be “fixed” without overhauling the basic concept of the lunar base design. The usual lapses were in terms of providing sufficient radiation protection.

In no particular order, the top lunar base designs were:

- Moon Capital
- The Crater Colony
- Moon Capital – Seed of Life
- Moon Capital – Home is where the sun always shines
- L.E.A.P.
- Town Planning Mostyrando
- Cratersville
- UniverCity
- Fort Rille
- Moonbase

Even after this process, a technical feasibility and elegance prize and a few honorable mentions still had to be awarded. This was not as simple a task as it may seem because many of the bases included very similar ideas and often the weaknesses in one design were similar to those of another. However, there were two standouts and then a second tier of bases that were beset by similar problems. The top two were clearly Moon Capital and Cratersville. Dave Linke concurred with this decision, and he had used a totally different judging system. However, the expert reviewers were not entirely on the same page. Sherry Bell also identified Cratersville as the top choice, but did not have Moon Capital as a close second. Randa Millirone had them both identified as leaders but saw 3 other designs as roughly comparable and did not distinguish among his top 5. Ed Kiker was excited about Fort Rille, the design with the force field protection. He rated it in the top 5, something no one else did. He also had L.E.A.P. as his first choice, which was ranked 5<sup>th</sup> for us and Sherry Bell. Kiker saw Cratersville as too conservative to be in the top 5 but Moon Capital was his #2 choice. We decided that his criteria were more technically interesting than technically feasible given his comments, but that was fine. Randa Millirone was no help having rated both leaders the same.

We decided to just look at how Edward and Sherry rank ordered what were in our view the two leaders. In short, the two experts that would rank order the leaders disagreed on the order and did not break the tie. Still, this reassured us that we had found feasible designs and that the leaders were worth further analysis. It was interesting that Sherry Bell gravitated so clearly to Craterville despite the modest graphics depicting the vision of that base, and that Moon Capital did not make her top 5. However, Ed Kiker did the opposite and mentioned only Moon Capital in his top 5, so their two votes cancelled.

We were headed toward a tie for first. The major reason for this decision was that we felt they were the two posters that included the most complete base designs. Both Moon Capital and Craterville had similar designs, they were both constructed into the side of a crater, contained a gas and water mining system, the possibility of economic sustainability though Moon Capital followed the rules which suggested that it was a scientific research facility rather than a mining camp. Both had an extensive agriculture unit, as well as a very modular construction plan. Craterville, however, seemed to be the more ambitious design, with ideas such as the lunar sling launch system using tether technology and their nuclear facility containing a fusion and two fission reactors. Moon Capital proved to be the more reliable and feasible design with a complete floor plan for the entire base, a conservative approach (relatively speaking) towards construction into the side of the crater. Craterville was using the bedrock for support and putting thin fiberglass units into the excavated levels to hold the gas atmosphere. Moon Capital removed all the loose regolith dust and put up structural steel and then pulled back the overburden for cover, and did it pretty much by the numbers, meeting the minimum of 3 meters rather than going down 10 meters underground like Craterville. Being closer to the surface Moon Capital had included a unique idea for a rotating solar panel and light reflector. It occurred to us that the award should be split into two titles, the technical feasibility prize, and the technical elegance prize. Moon Capital was given the technical feasibility award, and Craterville was given the technical elegance award. It was more of a reach, but if all this stuff worked, the economics of space would be transformed and

the social implications would be huge. Above all, we knew that these designs were basically compatible and we yearned to take elements from both and reassemble them into the “perfect” feasible design. Since we commended many components of each one, it was hard to rate one better or worse than the other. Also, Moon Capital had better graphical presentation, and that had to count for something even if its economic case was not as developed.

## AIAA Judging Presentations

Following our judging process, our focus shifted to presenting the finalist results and the major concepts in each design. In effect we wanted to present the finalists to other audiences and see if they concurred with our assessment. Would they see something that we had not that would break the tie? A presentation was created that included our top ten finalists from the SHIFTboston contest, with detailed images of each poster. Since the AIAA New England had tasked us with completing the judging process, we spread the word to the chapter that new “finalists” had been selected. In addition to presenting the new judging process and results, the presentation was also intended to elicit the opinion of the audience. The members of the AIAA would provide more insight from different perspectives, and valuable feedback regarding the validity of certain design concepts could be gained from those with more experience.

Two different dates, times, and locations were selected for the initial presentations. The first event occurred at Imperial China Restaurant in Framingham, MA on December 8<sup>th</sup>. An invitation was sent out to numerous AIAA members, as well as some personnel from the SHIFTboston competition. While the turnout was less than impressive, it was a valuable practice run for the presentation the following night. A number of questions were asked, and more importantly, the vision of using the winning posters to design a composite and then eventually design and build a simulated lunar base as an exhibit was discussed. The second event occurred at WPI in Higgins Labs the following night on December 9<sup>th</sup>. This event had a larger audience of mostly WPI students, but many of them were aerospace majors, and many were involved in the WPI student chapter of the AIAA.

During both events, all of our top ten lunar base entries were shown followed by an analysis conducted by David Linke. His analysis used quantitative data from the entries to rank them in various ways, such as safety, agriculture, radiation protection, feasibility etc. By his rankings, Craterville and Moon Capital were very close in score but Craterville had a slight edge since he did not consider the



quality of the presentation at all in his system. A questionnaire was given to the contestants of the event so that they could rank and comment on the entries after they were presented. Following the analysis presented by David, the rankings done by the attendees were tallied and revealed so that everyone could discuss reasoning behind their winning poster choice. The information gained from these questionnaires was extremely valuable, as it gave us a reassurance in the superiority of our own winner selections. There were a few entries that were commonly picked as the best designs of the top ten, which was what we had hoped for. This was especially promising because they generally aligned with our selection of the winners. A key moment in this event was that the AIAA members got talking about the lunar sling in the Craterville entry and got more and more enthusiastic about it. It became clear they considered most of the entries underpowered and that nuclear reactor coupled with the use of solar energy to run the agriculture unit appealed to them. With it they thought that the sling would work and was a valuable idea. This was a surprise to us. We had been critical of that as an unnecessary reach beyond existing technology. Rockets delivering freight from the moon already had a huge advance over those lifting off from Earth. Hence, we did not see the economic payoff as being worth the risk- until that night. The implications of that system being a plus rather than a minus, as it was for us, broke the tie and Craterville was ranked higher than Moon Capital by this audience.

David Link did an analysis involving all the votes gathered thus far, including ours and came up with perceived feasibility ratings of Craterville 33, Moon Capital 28, Mostyrando 20, LEAP 12, and a tie for 5<sup>th</sup> place at 11 for Crater Colony and Home is Where the Sun Always Shines. Since it was clear that everyone was (in summation) endorsing our perception that there were two standouts, and we still felt that superior aesthetic depiction had to count for something even in a technical feasibility review, we called it a tie for first.

Another observation worth noting was once you got the WPI students together many of the questions and comments had to do with taking several parts/concepts from different lunar base designs and combining them. While there was not one single entry that touched upon and addressed every challenge, many of them had several valuable and unique ideas that could be combined together to produce a very exciting composite base design. We were not alone in coming to that conclusion either. So, the next step was to get on with developing the imagery that Craterville should have had at the time of the contest and the production of the composite base image that we could see coming out of the top 5-6 entries.

## Composite Base

The idea of a single composite base that combines the best design concepts from each finalist helped our group refocus on designing the lunar base exhibit. Plans for the exhibit would be built around this composite design and we would work to incorporate all the major components of the base into the chosen location. The judging process also helped us better understand the challenges presented in designing a facility in such a hostile environment, and how to overcome many of those challenges with innovative ideas.

For example, one of the most obvious differences between the Earth and the moon is the difference in gravitational acceleration. Because of the smaller mass of the moon, the gravitational force there is only  $1/6$  that on Earth. This presents a formidable obstacle for permanent human habitation because the human body is highly optimized for Earth's gravity. The result is what is known as muscle atrophy, or the degradation of muscle tissue over time due to inactivity. While this adaptation is acceptable in the low-gravity environment, those who return to Earth are faced with severe weakness and often cannot even stand on their own.

Several of the lunar base design concepts acknowledged this problem and invented a plan to overcome it. The L.E.A.P. design employed modified stairs that were specially designed for the moon's gravity. On Earth, stairs are typically longer than they are taller, to make it easier to walk across them. L.E.A.P.'s stairs are designed with the opposite dimensions – with steps that are taller than they are longer. This design requires someone who is walking up them to exert more upward force, to simulate the walking experience on Earth. This innovative design also requires more effort be expended while walking, which helps prevent muscle atrophy.

similar idea taken from the UniverCity entry was to make the ceiling clearance up to 30ft in high traffic areas of the base. This would allow extra clearance for the increased vertical component of the walking/running cycle in  $1/6$  gravity. This would not only help to ease and increase the speed of

travel to and from locations in the base, but would allow the astronauts to get Earth-equivalent exercise on a regular basis.

Clearly, the SHIFTBoston competition gave these concepts great exposure. While the difference in gravitational force is an obvious challenge, there are several other important hurdles that require just as much innovation and creative thinking to overcome. The collective finalists provided numerous solutions to problems such as economic sustainability, transportation methods, housing and other structures, radiation protection, energy needs, and location, to name a few.

To help identify the components that a composite base will have to address, we broke the major challenges down into groups, and looked for solutions in each of these categories in each of the finalists.

#### **Major Focus Concepts**

- *Core Habitat* – This includes how the people live on the base, what their daily lives will entail, what their living quarters are like, what entertainment there is on the base. The core habitat is very important because the morale (and ultimately survival) of the inhabitants will all depend on their way of life.
- *Energy Production* – How the composite base is going to generate and use energy for light, electricity, heating, air pressurization, and so on. This is vital to the composite base, because there were many different approaches to this problem from the various entries.
- *Agricultural Unit* – Agriculture is an absolute necessity for any permanent facility in space. This is because it is too inefficient and expensive to ship up food to the moon, so everything eaten on the moon must be grown there from seeds that produce more seeds. The agriculture unit is therefore a core component of the composite base.
- *Radiation and Space Debris Protection* – Clearly, any successful base can be rendered useless without protection from solar radiation and space debris. Even though the solution to radiation exposure may be as simple as a layer of regolith between the core habitat and the surface, it is still an important consideration. A permanent base on the moon is simply not possible without complete radiation and space debris protection.

To ensure that the base inhabitants are properly protected, the concept of building the base into the side of a medium sized crater was adopted. This idea was used by multiple entries and it proves to be the best way to use a natural resource to defend against the sun. The crater would need to be large enough that the curvature of the side did not make it difficult to construct. It was agreed that Shackleton crater is the best location, because the diameter is about 20km and it receives almost constant light on its edges. At the top of the crater, robotics would be used to excavate deep into the side of the crater at several elevations. It is important to keep layers of regolith in between each level of the base for structural integrity. A thin layer of concave windows would be installed at the end of each level looking out into the center of the crater. The concave feature was adopted from the Team Goddard entry and is used to scatter the light in the base as well as keeping the pressure inside the base from bursting the windows, as the pressure is pushing out rather than in, which is uncommon on earth.

The core habitat essentially has to be designed around the more vital systems of the composite base, such as the agricultural unit and energy producing facilities. The living spaces and socializing spaces of the composite base need to be modular to make it easier and more efficient to construct. Many of the designs in the SHIFTBoston contest contained this modularity. The rooms for individuals and families need to be square and compact which will keep the amount of material needed for the core habitat low. These rooms need to be consistent, and not custom made, so that the manufacturing process on the moon is not complicated. We liked the room designs from Moon Capital, Cratersville, and L.E.A.P. L.E.A.P had a more unique way of keeping the modularity of the base. This base used a honeycomb pattern for each "room" within their main core habitat. This increases modularity by eliminating space between each room, but is a more interesting design, increases structural integrity, as well as allows for vertical stacking of each module. Below is an image from the L.E.A.P poster showing this unique design, as well as room images from Cratersville and Moon Capital. It would be useful to use the square design for individual living quarters for the inhabitants, and for the dining rooms and other

more open spaces, use the honeycomb design. This is because the honeycomb design allows for a larger area inside the room, and is more efficient when in use for a larger room.



Figure 5 - Living quarters from Moon Capital



Figure 6 - Living quarters from Craterville



Figure 7 - Living quarters from L.E.A.P.

It is very important, as mentioned previously, that the people living on the base keep up with exercise and fitness. This is even more important as the process of colonizing the moon gets advanced, because the shifts for being up on the base will most likely be longer over time. The goal for all the inhabitants will be to ultimately return to earth, so they need to physically be able to function back on our home planet. In addition to the more challenging stairs and higher ceilings for leaping to and from locations, adequate exercise facilities need to be available on the composite base. Cratersville, the Team Goddard entry, introduced a unique and more serene facility for exercising and specifically running on the moon. Around the outside of base along the crater edge on certain levels, there will be a “park” with “trails” where people can ride bikes, run, rollerblade, and perform other recreational activities all while taking in the fresh O<sub>2</sub> from the plants around them. This will provide not only a physical but emotional boost for the astronauts on the moon. That is something that we felt would be important to include in a composite base, even though many entries ignored the emotional toll that this isolating experience in a very small town with a lot of robots doing most of the work would have on a human. Of course, with 60 people isolated in a small base for several months would create some

controversy. So controlling the emotional strain on the humans to as little as possible would be ideal to prevent a psychological disaster.

The agricultural unit of the composite base is what provides most of the oxygen and all the food for the men and women on the moon. Without it, even a simple permanent base would not be feasible. In our composite base, this unit would be located in the back deeper in the side of the crater. There is a strong agricultural presence throughout the base outside of the agriculture unit. This is mainly for emotional purposes and aesthetics but also for oxygen circulation. This is evident in the “park” that would wrap around the front of the base along the crater side, which was mentioned above. The main agriculture facility is large and rectangular with many long slender beds of plants for food, oxygen, medicinal applications and other purposes. A critically important plant that will be grown here are cattails. Every part of the cattail can be used for applications such as water filtration and food. They are a very valuable resource and it would be easy and cheap to transport the seeds to the moon. Clearly, to grow the plants in the agricultural unit, light is needed, however natural light would provide better energy for the plants than electricity consuming gro-lights. . In order for the plants to gain natural light, while filtering out most of the radiation there needs to be some way to reflect the sunlight into the unit. A solution adopted from the Moon Capital base can be seen below.

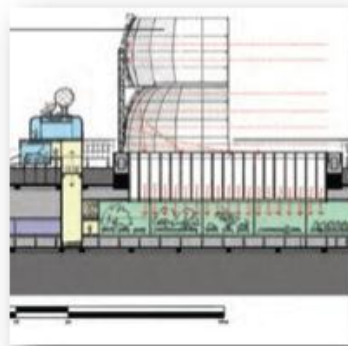

Figure 8 - Moon Capital light reflector



The bottom half of the reflector directs incoming light rays down and into the agricultural unit. The “tubes” in the picture, which act as a ceiling for the agricultural unit, actually help to filter out the radiation, while allowing the light to pass through and grow the plants. The top portion actually has solar panels mounted on the surface, collecting energy for the base. This whole component is mounted on a track that can rotate the reflector around to the optimal position to collect as much light and energy. Moon capital used magnetic levitation to do this, however, we feel that this is unnecessarily complicated and would probably cost too much. It also will draw continuous energy to support the structure, and a simple solution is better for this first robust lunar base. It can get fancy later when there are many units doing the same thing and thus there is some built in redundancy.

Unfortunately, the energy needs for the lunar base will exceed the amount collected by the light reflector. Because of this, other energy harvesting methods need to be implemented. A nuclear facility, composing of a fission and fusion reactor is a valuable tool for the lunar base. Helium-3, a resource readily available on the moon can be used for the fusion reactor, however even after fusion technology has been mastered to this degree, a fission reactor will be used to power up the fusion reactor when it has to be started up after shut down. The fusion reactor requires a magnetic field to operate and that field can't exist without a prior energy source. These nuclear reactor processes will do two things for the base. First, they supply a substantial part of its power, especially electric power, and also represent the day when that Helium-3 is both a valuable export from the moon that can be used back on Earth for fusion reactors and the day when lunar living can be based on a relatively cheap available local energy source other than the sun. That will clear the way to move production facilities to the equator where the temperature extreme are great and half the time one is in darkness during nights that are 14 Earth days long. We think that the only other way this region could be fully developed would be if space based solar power were being beamed down to a base on the equator during the long lunar night. It is also

possible that one could collect enough energy in the 14 Earth day period of daylight to last through the equally long period of darkness if one had superior energy storage and battery charging systems.

In addition to Helium-3, ice will also be mined from the lunar regolith. It is known to be in abundance at the bottom of many craters towards the north and south poles of the moon, another good reason for locating the first base on the rim of Shackleton crater. The ice is there but perpetually frozen, because the bottom of the crater sees no light. This is a good thing, because if the ice were to thaw while exposed to the vacuum of space, it would merely dissipate away instantly, leaving the moon bone dry. Fortunately, this is not the case, and the bottom of Shackleton crater can be harvested to supply the base with water.

There is a debate going on between the Japanese and Americans about the kind and amount of water to be found in Shackleton Crater. The Selene mission of JAXA imaged the crater and it looked “dry” no water ice. A joint ISRO/NASA (Indian space craft and American instrument) mission called Chandrayaan-1 later revised the estimate that 80% of the water was at the south pole to 40% at the south pole and about 60% at the north pole. About 40 mostly northern craters were demonstrated to have ice in the bottom. However, then a phenomenon called “dry” water that is 95% water but looks like a powder was documented on Earth. If small silica particles surround a droplet of water it can't form into a larger pool and form a visible ice, though the hydrogen signature is still there for sensors to pick up on. Thus it is quite possible that the Shackleton water supply is in the “dry” granular form and will have to be extracted rather than just melted.

However it is done, after the water is mined from the bottom of the crater it will be transported up to the bottom level of the base using a closed tramway system. The water has to be enclosed at the point when it hits the sunlight. This system will then deposit the (probably salty) water in a distilling tank within the lunar base. Using solar power, the water will be boiled and purified where it will then be ready for circulation throughout the lunar base. During the purification process, other impurities will

have been filtered out, however these impurities are by no means useless. This slag will contain silica, oxygen, iron, helium, aluminum, and titanium. The silica can be used for glass production, the oxygen for breathing and rocket fuel, the iron for support structures in construction, the helium for inflation of temporary surface structures as well as exported, and the aluminum and titanium are used for freight containers and other construction materials. Almost anything needed can be manufactured or produced from the materials extracted by the mining operation. This capability for ISRU (in situ resource utilization) is fundamental to this lunar base concept, and it must be realized and understood that this base is fully sustainable once these capabilities are added to its extensive greenhouse based production system and fish tanks.

Following the completion of our composite base conceptualization, an exterior CAD model was made as well as interior renderings to try and illustrate the design. Below are various external and internal images of our composite base.



Figure 9 - Composite Base depictions

## Exhibit Design

It is our hope that a future SHIFTBoston contest will take place, similar to the past lunar base contest, but this time to design the best simulated lunar base education exhibit that will fit in a chosen building. This idea will be described in more detail in the proposal section. It is important to note that before this contest idea was probable, we were the team with the objective to design the exhibit. During that time, a great deal of thought was put into nature and goals for the actual lunar base exhibit which can now be turned into contest guidelines. These are described below, and it is important to note that a description of how this architectural challenge should be tackled (much like what Marc Cohen provided for the last contest) is necessary to structure the next SHIFTBoston contest if it is to take place. The challenge in this case is to evoke an arresting image of an exalted goal in the dank cellar of an old dilapidated public building.

The correct look and feel of the final exhibit built is one of the most crucial concepts that must be achieved by the architects. One of the best ways that children learn is through visual and hands on methods. It is important that the exhibit displays an accurate depiction of what a base on the moon could look like in the future, while also being visually appealing and interactive. While designing the exhibit, the ultimate goal of this project needs to be kept in mind. It maybe tempting to create a museum of sorts that describes in high detail the future lunar base, it may also be tempting to design a “playground” for the exhibit visitors with less detail. In order to educate about the base while simultaneously sparking a great interest in the fields of science and engineering, a balance must be achieved. It can’t constrain the imagination with too much detail or be too open-ended, given the actual constraints of the lunar environment. It has to work there, though not necessarily be the only or best possible way to solve a problem.

The design of the lunar base exhibit will consist of architectural drawings and conceptual drawings in addition to a table top model portraying the exhibit built from a three dimensional CAD

model. This amount of detail will ensure that the important details will be preserved toward the completion of the project, including specific ideas learned from the SHIFTBoston contest. It is crucial to maintain these ideas to continue the momentum and knowledge built up by the lunar base contest, and prevent starting from scratch when construction actually begins. There are several computer-generated images and models from Team Goddard's design, as well as the other contest entries that will aid in developing a conceptual exhibit entry, but in the end it is an illusion and depends on the imagination of the viewer to make it educational. As more is learned from the contest results, detailed drawings can be produced from these ideas for an actual exhibit. It is from detailed drawing that one can get a reasonable price estimate. After deciding what the optimal design is for the lunar base that will be depicted to the visitors of the exhibit, certain objectives must be met to ensure that the design is educationally successful and affordable enough to eventually be constructed. Below is a list of the major objectives to accomplish:

- Design and create a tabletop model of the lunar base exhibit depicted within a suitable building. The model will be displayed inside a transparent housing in which the final exhibit will be constructed, to show how it fits within the structure.
- Along with the tabletop model, a conceptual plan of how the base will look and how it will function needs to be written up. This could take the form of a CAD model, artistic drawings, architectural drawings, and/or functional drawings.
- Develop local contacts for advancement of this project in the future. This would include political figures in the city of Worcester (especially those concerned with public education), the colleges of Worcester, area architects, artists, interior decorators, and transportation companies. The affected neighborhood organizations and homeowners and contractors, and/or construction companies that could help work out the neighborhood role and cost of the proposed construction project should also be

consulted. Vested interest groups hoping to profit from the effort and that do not care about its purpose or success must be approached with caution.

- We need to work with the educators in local school systems especially closely since NASA has never made a case to the public for a lunar base. Much of the vision we have to offer will seem startling and the exhibit will be making claims that are factually based but not a matter of wide consensus at least at first. This creates a problem since we rarely include in texts for school children in anything still considered debatable. This is unfortunate since science in inquiry, debate and a process of sorting through the evidence and then grounding public policy- which involves yet another debate.
- As a potentially profitable exhibit one wants to say something shocking as well as enlightening. The public audiences coming to learn about how a sustainable, profitable and functionally self-sufficient lunar base is possible will add to the exhibit cash flow over the summer when the schools are closed and in the evening when school is not in session.

It is important to identify specific topics that will be focused on at the future lunar base exhibit. The transportation system, light and power production, food and water production, and the overall structural feel are the major topics that go beyond the exhibit confines yet need to be depicted suggestively in the exhibit.

The transportation system includes the methods for people traveling to and from Earth, transporting freight (both exports and imports), as well as robotic and human transportation on the moon, sometimes involving special handling requirements as for ice and LOX. This topic will be entertaining for kids of all ages to learn about, specifically the robotic and rocket powered elements of the system.

Team Goddard has also come up with a unique and exciting way of launching exports into orbit from the moon, crudely described as a very large slingshot which can reach escape velocity of 1.4 km/

sec. Other concepts, such as robots that build other robots and assist humans in everything from construction to mining to operating in space to run a rocket fuel depot in LEO will be very interesting to students, while also incorporating a very good way of educating them. Education in all types of science and engineering would be covered, such as mechanical, electrical, robotics, aeronautics, astronautics, and many others. The transportation system is also essential to the bases economic sustainability and functionality, so it is important to understand. The LOX from the moon rocks is not headed for Earth, it is going to the orbiting fuel depots in LEO so that rockets can be refueled after climbing out of the Earth's gravity. The implications of refueling in terms of the range of our current chemical rocket technology are astounding. Once in LEO one is halfway to anywhere in the solar system.

Depicting how the base will generate its power and maintain light in all places that it is needed on the moon is also essential. This is not just a solar powered base, though it is sophisticated and takes full advantage of the near continuous solar energy available at the lunar poles. It is also a nuclear fusion reactor research facility and has a reliable existing design for a fission reactor as well. Along with assisting in understanding the complete functionality of the base, learning about atomic energy is timely given the impending end of the oil era. Thus the base will be very educational at many levels and introduce many subjects such as physics and thermodynamics to students who can handle them. At the moment, fission and fusion nuclear reactors are not going to be described in detail to the younger visitors to the exhibit, but the more advanced topics will be very interesting for high school and above age groups.

Transporting light to places where it is needed as opposed to using electricity to generate it is possible on the moon in ways that would not be as feasible on Earth. One can track the sun and reflect it or bend it using fiber optics, which may also be part of the actual solution used on the moon. Radiation protection can be solved by using layers of water, air, and glass to "protect" the visitors inside the exhibit, which will also give the guests a good idea of how it would feel to be inside a lunar complex.



Many of these ideas were also taken from the Team Goddard entry, as it was the winner of the technical elegance award. However other solutions from the contest results have also impressed us and the architectural interior will involve features that are exciting to depict in the exhibit, though using them in Earth gravity will not be that easy.

Part of the exhibit that the visitors will be able to relate to the most will be the food and water production. How the astronauts will obtain enough water and food to survive will be something that we all need to do on a daily basis, the task is of course much easier here on Earth. Again it is useful to go to our local Team Goddard's strategy, to obtain a basis for how this will look. A major part of the habitat portion of the base (40-50%) will be an agricultural unit, so it will be essential to show how the survival of the plants growing in the base is vital to the base's success. This can be done by including plants extensively in the exhibit, and having an agricultural unit completely devoted to them with an atmosphere optimized for plant rather than animal health. That will mean almost doubling the amount of carbon dioxide in the plant unit's atmosphere and under those conditions potatoes will grow twice as fast and yams twice as big in the same period of time.

This is clearly a new era of space travel- not a few highly concentrated foods carried along but a new civilization which at \$10,000 per pound for anything delivered from Earth. One has to produce what one needs locally, especially consumables like food and water. The exhibit has to make it clear that if someone on the base is hungry, they will probably fill themselves with something made of plants grown right on the moon. Another interesting concept for the students will be the oxygen and water mining on the moon, and how the success of the base is extremely reliant on that endeavor. Team Goddard decided to build their lunar base at the edge of Shackleton Crater, which is very likely to have an abundance of water in some form at the bottom of it. Hopefully, it will be familiar ice, but it might be so-called "dry water". Mining this water will provide the base with oxygen and water both to sustain life on the moon and be used as rocket fuel. The trick of course is not to deplete this limited supply, so the

Team Goddard plan is complex. You get the initial water by going down the 30 degree slope of the crater into the zone of perpetual darkness. In the exhibit there will be a camera scene angle looking down toward a lit up complex mining operation with cable cars and robots. Then some of the water is filtered and enters the base biosphere but most of it is split in Hydrogen and oxygen. The oxygen is liquefied and sent to the launch site to be exported and the hydrogen is used to extract more oxygen from the regolith sand which is mostly iron and titanium oxide and hence 40% oxygen. About half of the oxygen will come off easily to form more water, and the hydrogen can be reused and reused to extract lots of Oxygen, which is abundant and can be exported. The hydrogen is precious and can be burned only to produce rocket fuel to launch a human into lunar orbit. All the freight can withstand high G forces is simply thrown into lunar orbit using the lunar "sling" powered by a nuclear reactor. This whole concept of how to mine lunar wealth and conserve resources at the same time is sure to spark interest in the visitors and educate them about many things important to the success of the base.

The last major element of the exhibit will be the objective to capture the look and feel of the moon in the vicinity of the base and contrast that to other lunar locations. This is extremely important to get correct as it explains why the base is where it is and "getting" that could be the deciding factor on whether a child or adult walks away from the exhibit inspired with the possibilities and wanting to be part of the development of a new world, or merely satisfied with knowing that something like this is possible. It is a major goal to leave 10% of the visitors awestruck and another 15% of the visitors ready to visualize in their imaginations the possibilities as if they were there. If 1 in 4, about the number that arrived with science as their favorite subject, feel that they were transported to a new world of possibilities and can envision being rocketed from Earth, coasting down to the lunar surface, and are ready to walk around in their own heads learning the rules of a different heavenly body the aerospace industry will never lack for technical person power, and some of them will be the best and brightest of a generation of engineers and scientists.

Engineers are unusually likely to be drawn from the pool of Introverted and Intuitive Thinkers in the general population. For example, 3-5% of the general population is INTP in terms of the Myers-Briggs Personality Typology but the WPI student body is 15% of this type (Martin, 2001). About 30% of the general population is Intuitive, but 55% of WPI students are. The goal of the exhibit will be to give the 70% majority of Sensing students something tangible that they can see, touch and feel hands-on to fully get it what life in their alien place would be like so that they understand the science and logically master the underlying concepts. For the others, who “get it” from reading and easily visualize abstract possibilities, the idea is to “transport” them to a new starting place and overwhelm them with possibilities that get their minds racing and let them build beyond what they saw racing each other to the next level of comprehension and conceptual integration. That is what we mean by “blown away” awestruck- and we think that is possible for 10% of the student views based on their reactions to just pictures of proposed lunar bases that were not fully developed with interior views and interesting details. We had 5<sup>th</sup> graders who were already lifting features from one image in their mind and putting them together around their favorite base concept, elaborating what we were showing them before we could finish describing them. These are our kind of people who do that instantly, intuitively, solving problems they have not fully articulated yet.

A location such as the Worcester Auditorium would provide us with a large mostly underground series of chambers in which to create an alternative reality. It is both a series of sets and a stage on which to enact a play that is less about a tour of the moon than a tour of the future through the lens of a telescope, narrow, but deep and evocative. When the visitors to the exhibit have traveled from the entrance of the auditorium, also known as Earth Shuttle, to the Little Theater where they see a movie that moves them from Earth orbit to lunar orbit the next step is to move into the stage which is also an elevator and will be set up to look like a shuttle craft designed to carry one class at a time to the lunar surface and into the base. As they drop down into the base exhibit underneath the stage they are

moving to not just the lunar surface but are being lowered those last few feet into an enclosed lunar habitat. In effect, their spacecraft is quite realistically being moved inside, before being opened. This interesting effect can be achieved at this location because the stage at the Worcester Auditorium is a relic of an aircraft carrier de-commissioned in the 1930's. Hence the whole stage can be lowered down into the basement of the building.

This is where the excitement would really begin, with the modest illustrative agricultural unit in one area but imagery that is much more impressive due to film foot age made at Tower Hill, a massive greenhouse facility that would look like it was right next door. Cameras, a classroom, multipurpose meeting room, medical facility, gymnasium, observation deck, dining hall, resident private living areas, all in their respective locations would be fragments of what the visitors were shown as the overall image on arrival. The most eye-catching scene will probably be the observation deck looking out towards Earth, and the windows filled with water looking toward the steep slope of the crater. Information for every age and scientific interest will be in the background and can be called up on computer screens but the core audience of 5<sup>th</sup>-8<sup>th</sup> graders will be catered to in the permanent display. If the exhibit is to spark interest in many fields of science they are going to have to feel like they can operate robots outside of the base that are doing something important and check in on an expedition exploring the equatorial region of the moon and build on to the base or send LOX to LEO or handle incoming freight and monitor the plants and change the atmosphere so that they can go have lunch in an agricultural unit or communicate with people back on Earth and go rescue a robotic truck that went off the road and got stuck due to an error by an operator back on Earth. In short, they have to feel like they were on the lunar base crew for a day. What they see through the eyes of the robots they operate and monitors has to be a really alien environment that does not operate by the rules they take for granted so that they learn about science concepts that were once abstract as they navigate in this new place and space.

## Tying the SHIFTBoston Judging back to the Curriculum Team

Our proposal for a lunar base exhibit is part of a much larger space education plan for the city in which it is to be built. It is important the final product be incorporated very closely with the local school system, or multiple school systems that would be able to have their students visit the exhibit on an annual basis. That is because this exhibit would be built in conjunction with a public school curriculum that uses space themes, or more specifically, the Moon, to teach students about the various science concepts currently taught in their schools. After some preliminary research, it became immediately evident that many of the concepts covered, including biology, physics and chemistry can all be taught and illustrated quite well in the context of a lunar base.

Our team worked closely with another whose goal was to design and test a space-based science curriculum unit. This 6 week space enhanced unit is different from what is currently being used in school systems across the country because it was designed to be part of a “spiral” curriculum. That means that year after year, students are taught new subjects, but cumulatively, all in the same thematic context. In our case, this would be the lunar base exhibit. For example, in 5<sup>th</sup> grade, students would learn about the location of the moon relative to the Earth, along with the rest of the solar system and get the lighting difference are different parts of the moon down and locate the lunar base so as to maximize its solar energy resources while getting down the Earth moon conditions comparison and finding out with natural resources are available. There would be some attention to landing craft differences with and without an atmosphere to contend with. These lessons would serve mainly as an orientation.

The following year, they might learn about the chemistry involved in the extraction of everything from oxygen and helium-3, to aluminum and titanium from the lunar regolith. In a subsequent year, they would learn about robotics and why surface activities are dangerous for humans. After that they would spend a year on plant biology and after that go through a unit about the physics of

orbital swings, and fission and fusion reactors. The goal of the spiral curriculum is to incorporate each lesson into a common theme. At the end of those lessons, students will have a fairly profound and integrated understanding of the workings of a lunar base and the technology and scientific challenges associated with its construction. The lunar base is of course, a microcosm of the Earth, with people trying hard to fit into that system, recycle everything and doing without things that can't be locally produced to minimize transfer costs. There is much to recommend this kind of thinking on the part of the next generation of planet Earth.

The lunar base exhibit would function as a central hub for this learning. While students spend most of the time in the classroom learning about the various concepts and background needed to understand the logic of a lunar base, they need a way to be able to touch something that isn't there yet. The lunar base exhibit would serve as an annual (at least) field trip for the students using the space-based spiral curriculum. One of the challenges of designing and constructing this lunar base is that it would need to be fairly detailed in many aspects in order to properly educate its visitors. It would also need to be attractive both to visitors coming in fairly cold at age 10 and 16 year old veterans of 5 prior trips coming to get down the details of the power plant, rocket fuels and freight transfer system. In some ways the returning veterans will be a more demanding audience than adults with engineering degrees coming in off the street, yet it is critical that the annual trips do not become stale over time. The tour guide must be well versed in the details, a biology major one year, a robotics majors the next and a physics major when the orbital mechanics and power plant come up. Each time students will visit the exhibit will be a chance to see and learn something that they were only vaguely aware of in the previous visit. They will also get introduced to a different technical field and meet someone studying it.

With this large-scale plan in mind, it became quickly evident that we needed to get the schools involved in the process of designing both the curriculum and exhibit. At the least we needed to try this

thematic and style of education out on the students, parents, and teachers to get an idea of whether our idea for a lunar themed exhibit and curriculum would be engaging. The best way to do this was to host a field trip to WPI in order to learn about various science concepts from robotics, to the idea of a lunar base itself.

In order to justify having various Worcester schools send all of their 5<sup>th</sup> grade classes to WPI for the day the experience was tied into preparation for the Massachusetts Comprehensive Assessment System, or MCAS test. Recently, the MCAS test started including required science sections, to test students' knowledge on basic science concepts. Since this is a new addition to the test, the science education goals in the classroom had to be adjusted and the Worcester Public Schools invested in new textbooks specifically to prepare for the test. In order to get students excited about science, the curriculum IQP team hosted an "MCAS Review Day" at WPI. At this event, students and teachers would visit various stations and learn about science concepts and their relation to space. There were robotics demonstrations, physics demonstrations, and our contribution, the lunar base design review presentation.

The organizers keyed stations for the students to visit that covered concepts that appeared in portions of 5-6 chapters of the new text for the proposed event. These chapters covered space (especially the moon-Earth comparison), materials, forces, energy, electricity and light (adding in some plant biology which should be a review from 4<sup>th</sup> grade). Our station was a bit different from the rest, both a justification of the theme and an integrative review as we were the ones to show how all the other materials fit together. Thus, an effort was made to schedule all the classes to come to our session.

By this point, we had analyzed the 89 entries we had received from SHIFTboston in great detail and chosen 10 of the best posters based on technical feasibility and elegance. The goal of the design review presentation was to explain to the students some of the important concepts displayed in each

design, and discuss why some things would work, while others would not. After a quick overview of five or six of the best base designs, we called for a vote among the student “design review teams” to pick the best lunar base- just as if they were working for NASA. On the other hand, given their age we let them know this was really about where they would prefer to spend a year at age 40, if they went to the moon in 30 years. It was our hope that they would gain a greater understanding of the challenges involved in building a lunar base, and the great excitement that comes with the exploration and colonization of space. What we didn’t expect was the unbelievably positive response we would get from the students and teachers alike as they got the idea that this was really possible- and in their lifetimes.

At the beginning of the presentation, we told the students that they were selected for a very important mission. That mission was to help design the very first lunar base. At this, many of the students’ eyes lit up at the prospect of having a real impact on what goes on in such a large-scale project such as this. As we presented each concept and the reasoning behind it, as well as the feasibility of it, we could tell that they understood the challenges involved in designing a lunar base, from local resource utilization, to radiation protection, to quality of life. After each of the designs was presented, we asked the students to vote as a group which concept was the best, in their opinion.

The results of this voting were very consistent with our own ranking. When looking at the overall results of the vote, it was essentially a tie between Moon Capital and Craterville (our two top-scoring designs). This shows that many of the students saw great potential in the completeness and feasibility of these designs. One student actually told us that he liked the “tether” (lunar sling) idea, but would like us to find a way to incorporate it into the L.E.A.P. design concept. That showed that they really put thought into which base they voted for.

In addition to the voting results, we also paid very close attention to the reactions from the students to the idea of building and living in a lunar base. The first group was very excited and had a lot



of energy. We ran through the presentation, and loved to see the reactions to some of the designs (especially the lunar sling concept). The not-so-great bases definitely got some laughs and smiles, especially the one with oil derricks and happy meal boxes. We finished the presentation with about 10 minutes to spare, during which we opened up the floor. For the whole time, we had about five hands raised, and all with good questions too, about getting to the moon, and how glass and concrete could be made from regolith, and even got a comment about how wormholes could be used to make space travel more efficient.

The second group had just about the same enthusiasm, but with one distinct difference. One student posed the question, "are you going to build a model of it?" We replied with the answer that we are actually planning on building a full-scale model that they'd be able to visit and walk around and interact with. Then we posed the question, if we were to build such a place, who would be interested in visiting it on a field trip or otherwise? Every hand in the room went up, along with smiles. That was one of the best things about the design review presentation, was seeing the support and interest we would get from the students to build this exhibit. As this group was leaving, one of the teachers approached us and said that they were from the Goddard School. She said that they never really teach much about the moon, but after seeing this presentation and the other stations, its' obvious educational potential encouraged her to incorporate the moon into her teaching.

The third group had less energy, but was definitely still interested based on their voting and numerous questions. Every group had no shortage of questions.

After lunch, we started the next group (Clark Street) at about 12:15. Despite being a small group, they were all engaged and actively discussed the advantages of some of the base designs.

We missed our last group as they went to the wrong room, and that was unfortunate, but from what we hear they had a fine discussion about college life with their guides.

The MCAS Review day was a great opportunity for us to gauge what sort of response we can expect from the students for whom this lunar base exhibit will be designed. It was truly remarkable to see how enthusiastically the students reacted to the idea of a lunar base, and the sheer enthusiasm they had for the idea of actually being able to take part in a project like this in the future. It was also astonishing to see the level of knowledge these students already have about modern technology and research as it relates to the space industry. Educators should take advantage of this excitement and teach these students their science lessons in a way that relates directly to their interests, instead of just showing equations and past experiments. Learning is certainly easier when you are interested in the subject, and there is no reason to “swim upstream” when it comes to teaching students, especially at an early age.

In addition to the great responses we received from students and teachers, we also received positive feedback from Dr. “Fred” Bortz, who presented to the students as well. Dr. Bortz is a professional public speaker and author who encourages young students to get interested in the space field. The focus of his presentation at this event was to show the students that they stand a great chance of being the first generation of people to help support or actually live in the first permanent space colony. We had the pleasure of presenting alongside Dr. Bortz the following night in a presentation to teachers, parents, and administrators about the idea of constructing a lunar base exhibit.

As one of the goals of both the curriculum team and our own, we had often discussed how valuable it would be for the project if a book were to be written for 5<sup>th</sup> graders in narrative style about living and working in a lunar base. It would not feel like a text, but would support the students who would be participating in the classroom and visiting the exhibit. Since Dr. Bortz has written many books on the subject of space specifically for this audience, we thought him a perfect fit for the task. Working

with the curriculum team, Dr. Bortz would be able to compile chapters based on the various subjects included in the learning outcomes.

Our exhibit team would be involved with incorporating each of those learning subjects into a lunar base exhibit design, and depicting it in detail and illustrations of bases and parts of bases could be used in the textbook. We met with Dr. Bortz during his visit to go over our choices for the best lunar base designs based on technical feasibility and elegance. He had a lot to say about each one, and he was astonished to see the sheer amount of diverse ideas that were presented in only the top 5 posters. Dr. Bortz seemed receptive to this idea, of writing a book about lunar base living.

There is a real hope of including him the future of the project. We are told that by the time our advisor dropped him off at the airport he was discussing he need for a book series editor to coordinate all the books to go with each grade step of the spiral curriculum. By then he was talking about how he wanted to write the first one for 5<sup>th</sup> graders and maybe one of the other that dealt with the physics side of the lunar base. He did not feel qualified to do the plant biology side of it- but had some ideas as to who might be. We clearly got his attention.

### **The Midland School Presentations**

Following the success of the presentation to the students during their field trip to WPI, we wanted to continue to present as few more times, the way Dr. Bortz said he like to do it. What he liked to do was go to the school and present right in the classroom of the students. It would be a different experience, because the students would not be at WPI and instead in their own classroom, we could see if a different reaction occurred. The presentation at WPI also included multiple other presentations, feeding knowledge to the students before our design review presentation. These previous talks undoubtedly gave the kids a better perspective on what a technically feasible lunar base would look like. It also may have given the kids more excitement and enthusiasm in the subject.

By presenting to a new set of students without these presentations before, we would be able to judge whether the great interaction and reaction from the kids at WPI was only really coming from the stimulation of the lunar base design concepts or more generally due to the fact that they were “in the mood” for the moon. We would also be able to tell if the students were as educated and knowledgeable about the moon, and able to pick similar top bases as the WPI field trip students did.

The presentation began at the Midland school on Tuesday February 15<sup>th</sup>, with a few technical problems. The presentation would not load through the schools wireless network, due to security issues. This however, did not discourage the children at all. We improvised our presentation to include a brief talk about the moon and what the students already knew about space and science. This talk was by no means a one-way lecture, and the students were already well engaged with the speaker, asking multiple questions and making interesting comments. Some notable remarks include one student asking if a dome would be a good structure for a lunar base, another asked if there would be a classroom on the moon, and one other mentioned that trees could be used to help the astronauts breathe. It seemed that with just a little excitement and motivation, the children were all of a sudden future astronauts, begging to contribute to this endeavor.

It was truly remarkable, watching hand after hand go up in excitement, before the official presentation had even begun! One last task that was given to the students before the design review was for them to draw what they thought a future lunar base would look like. They were very excited to share their innovative ideas to their peers, teachers, and presenters, and the designs were impressive for the little knowledge given to them on the subject. Many of the designs were underground to protect against radiation, had multiple agricultural facilities for food and oxygen, light reflectors and solar arrays, and other scientific and interesting ideas. Next, the design official presentation was given and the student’s interest did not fade in slightest. In fact, it took longer than normal, because of the multiple

hands raised over and over again. The motivation and enthusiasm was clearly there, however, when the students were asked to decide upon what they thought was the best design, the results swayed a bit from the WPI field trip students. Craterville and Moon Capital were not the top choices; instead it was spread around more, with the top entry being L.E.A.P. It is interesting to note however, that the new image created for Craterville was not displayed on this presentation so it was not a graphically appealing and of course the students did not know what the contest rules were and which ones LEAP had ignored.

This experience at the Midland school showed that the students' creativity and interest in the subject of the lunar base was not dependent on the previous knowledge given to them on the subject. It also revealed that it is important to educate these children in the scientific fields relevant to a lunar base, because the safest and most well fed lunar base was clearly not chosen when graphics and large scale were allowed to overwhelm secure and balanced base concepts. This experience led us to wonder whether a traveling presentation day would be feasible, where multiple talks and demonstrations are given throughout the course of the day by teams coming in one right after the other? These would all happen at one school and be similar to the information given on the WPI field trip day in January. The final presentation would be the design review, and with the knowledge and know how given earlier in the day, the students would be able to make grounded judgments on what lunar base they thought was best on various grounds. It is important to realize though, that no matter how much the students know before the presentation, there is no shortage of motivation, creativity, and enthusiasm for this theme. Our advisor's reaction to the idea of the traveling road show rather than setting up all the stations at WPI, was that the elementary school principals seemed to greatly value the idea of having their students see a college and get a tour to go with the exhibit, but it was nice to know that both models were workable.

## Future Momentum

Based on the success of our work with the curriculum teams' MCAS event, we decided we were gaining momentum. Also helping us was Kim Poliquin, from SHIFTboston, who wanted to know if the AIAA New England would be willing to be a co-sponsor for next year's space oriented competition? Our group discussed this for a while and decided it would be beneficial for the AIAA New England to once again sponsor a SHIFTboston event if certain rules and regulations could be made so that everyone in the competition was on a level playing field and had to take the technical constraints into account.

Originally we wanted to limit the entries to using a few pre-selected buildings (preferably in Worcester) we thought it might be best to make the contest more general. Hence, we proposed the idea of a simulated lunar base built in an abandoned or underused building in a city with a population of at least 250,000. In addition, because the main purpose of the lunar base science exhibit is to enhance the learning of young students, we also proposed that the city used by the entrants in their design, must have at least 20 elementary and middle schools. By confining the entrants to using a certain type of building in size, it is our belief that there will be a much larger selection of serious entries that will produce great amount of ideas for a city to use. Also, by restricting the building type one can level the playing field. What one could do an a new specially built building designed for the purpose is in a way less challenging than retrofitting an existing cavernous cellar to be an underground base.

One of the greatest benefits to using a building in Worcester, is that we have obtained the dimensions of a building in which we deem ideal for this type of exhibit. To further entice entrants to use a building in Worcester, our group is trying to work with the City so that the winner(s) of this contest can be considered for an actual contract for the design of this exhibit as part of refurbishing part of the building. By offering this incentive we believe the level of excitement as well as the quality of the entries will increase dramatically. More and better designs entered will in turn give the city of Worcester better options while deciding the best use for the abandoned building that we have in mind, which is the

Worcester Auditorium. Our formal Proposal to the City of Worcester to work with SHIFTBoston and let the Auditorium be a site architects are encouraged to use in this competition is appended to this report.

In addition to the formal proposal to the City of Worcester, many presentations are also planned for the next several months to educate the public about the goals of this project, and to continue the public support and momentum that has helped us through this project so far. Some of the professional events we plan on attending include:

- The New England Undergraduate Research and Sociology Conference on April 15, 2011. This event provides a unique opportunity to present the sociological impact associated with a future lunar base. Also at this event, the results of David Linke's analysis of the competitions entries as a whole can be presented, along with his conclusions about what these results say about the public perception of the moon.
- The AIA National Convention in Washington D.C. on May 17-19. SHIFTBoston, having strong ties to the architectural professional community, is presenting the results of the Moon Capital competition, including our technical feasibility and elegance awards.
- The International Space Development Conference 2011 in Huntsville, AL on May 18-22. This event, sponsored by the National Space Society (NSS) will be a great opportunity to present to those interested in the future development of space infrastructure.
- The AIAA Space 2011 Conference and Exposition in Long Beach, CA on September 26-29. This event will be a chance to present our collaborative efforts with the AIAA New England chapter at a national conference.

Oral presentations at these events will undoubtedly serve to spread the word of our efforts to a wide range of audiences, and continue the momentum we have gained so far. The strongly interdisciplinary nature of the proposed lunar base exhibit and actual design means that professionals from all walks of life can get involved in order to support our cause and continue our efforts.



## Conclusion

America is struggling to re-establish its place at the top of the science and technology world, and our dominance in the space industry is waning. In less than 10 years, just in time for the 50 year anniversary of the first Apollo lunar landing, China may have already established themselves in a permanent settlement on the moon's surface. The United States is at a critical juncture to act, and focus our goals for the future of space exploration. Throughout this project we have seen the enthusiasm, interest, and excitement as well as the knowledge and know-how to construct a lunar base in the near future.

During the initial campaign of this project, the Craterville design, which we helped solidify, proved to us that a lunar base was a very feasibly and realistic concept for construction in the near future. A base on the moon is without a doubt technologically possible with today's technology, and this entry to the SHIFTboston contest included all the details needed. The poster provided a sound explanation for how energy and resources would be used through the extraction of water and materials from the regolith. They showed a base could be constructed and protected from harm in the side of a crater with nearly non-stop sunlight. A transportation system from the moon's surface to orbit as well as from orbit back to the surface was also ironed out in a space tether design. However, the most critical element we felt was that the base was designed to ultimately be completely sustainable and self-sufficient in terms of not only resource, but economics as well. The solutions to many fundamental problems proved that the concept of going to the moon and staying in less than 60 years is entirely possible, and that was great to take-away from our initial experience.

The SHIFTboston event became the focus of our attention shortly after the Moon Ball event in Boston. It is clear from this event that the interest to go to the moon for a lunar base is widespread in

location and industry. Many of the entries to the competition were submitted by architects and artists, not technologists. In addition, even after initially focusing our efforts solely on one base design (Craterville), we found a multitude of new ideas and unique solutions within the poster entries. The work of others was very important and valuable to us because numerous base designs provided concepts that we had never heard of or even considered. Clearly, for the task of designing the optimal lunar base, it would be extremely wise to combine ideas and the efforts of others. It also occurred to us that the technology included in nearly every feasible and technically elegant poster was created with technology that is already currently available. It is exciting to think that, if given the chance, today's society has the ability to build such bases as seen in this competition.

This immense interest in returning to the moon has driven the minds of many to come up with creative and innovative ideas never thought of before. The potential is enormous for future projects and competitions to design and construct a lunar base. The public reaction to these concepts that have been included in our presentations was very positive. Over the course of the project, we presented our findings and designs to diverse audiences, from elementary school students to architects to science and engineering students at the college level. The unanimously positive reaction from this wide range of students and professionals solidifies our determination that there is widespread interest in returning to the moon. The 5<sup>th</sup> graders, even after entering our talks with the previous knowledge that the moon was a dry, barren and uninhabitable place, seemed enthused to accept this challenge of constructing a base there. In only a short presentation showing what could be done, we were able to completely change their perception of the moon. They walked away knowing that one day we would inhabit the moon and were inspired to be educated on the subject matter. Ultimately, our goal is to improve science education while motivating students, teachers, as well as professionals to work towards a common focused goal of getting back to the moon.

It is evident that economics play a significant role in the scientific and technological goals of our country, and the world for that matter. Like any space exploration project, up-front costs are colossal. Unfortunately, past programs such as NASA's proposed and planned Constellation program, made no promises for a return on investment. The program almost seemed to be attempting to kill two birds with one stone, going back to the moon and reaching Mars. Due to the fact that the moon was thought of as a "stepping stone" or "practice" for going to Mars, and that there was no point in landing on the lunar surface, the importance and significance of the project was lost. The plan to go to Mars was lost, and so the Moon fell along with it. However, there are significant reasons to go the Moon to build a base, not just to go to Mars. We feel the goal needs to be refocused on two separate endeavors, and this time, the mission to the Moon will be different, because a sustainable base on the moon has the possibility of creating revenue. With a proven return on investment, the whole picture changes, and all of a sudden a lunar base in the next 60 years is not only technically feasible and valuable asset to our education system, but it is also economically and politically feasible.

## Bibliography

Martin, C. (2001). *Looking at Type: The Fundamentals Using Psychological Type To Understand and Appreciate Ourselves and Others*. Gainesville: Center for Applications of Psychological Type.

*MCAS Results, 2010*. (n.d.). Retrieved from <http://www.doe.mass.edu/mcas/2010/results/summary.pdf>

Savage, A. (n.d.). *MythBuster Adam Savage: 3 Ways to Fix U.S. Science Education*. Retrieved from <http://www.popularmechanics.com/science/mythbusters/articles/4279828>

Vaznis, J. (2009, September 3). *Science MCAS Stymies Many*. Retrieved from The Boston Globe: [http://www.boston.com/news/education/k\\_12/mcas/articles/2009/09/03/science\\_mcas\\_stymies\\_many/](http://www.boston.com/news/education/k_12/mcas/articles/2009/09/03/science_mcas_stymies_many/)

## **Appendix**

### **Our Poster Finalists for the Technical Feasibility and Elegance Award**

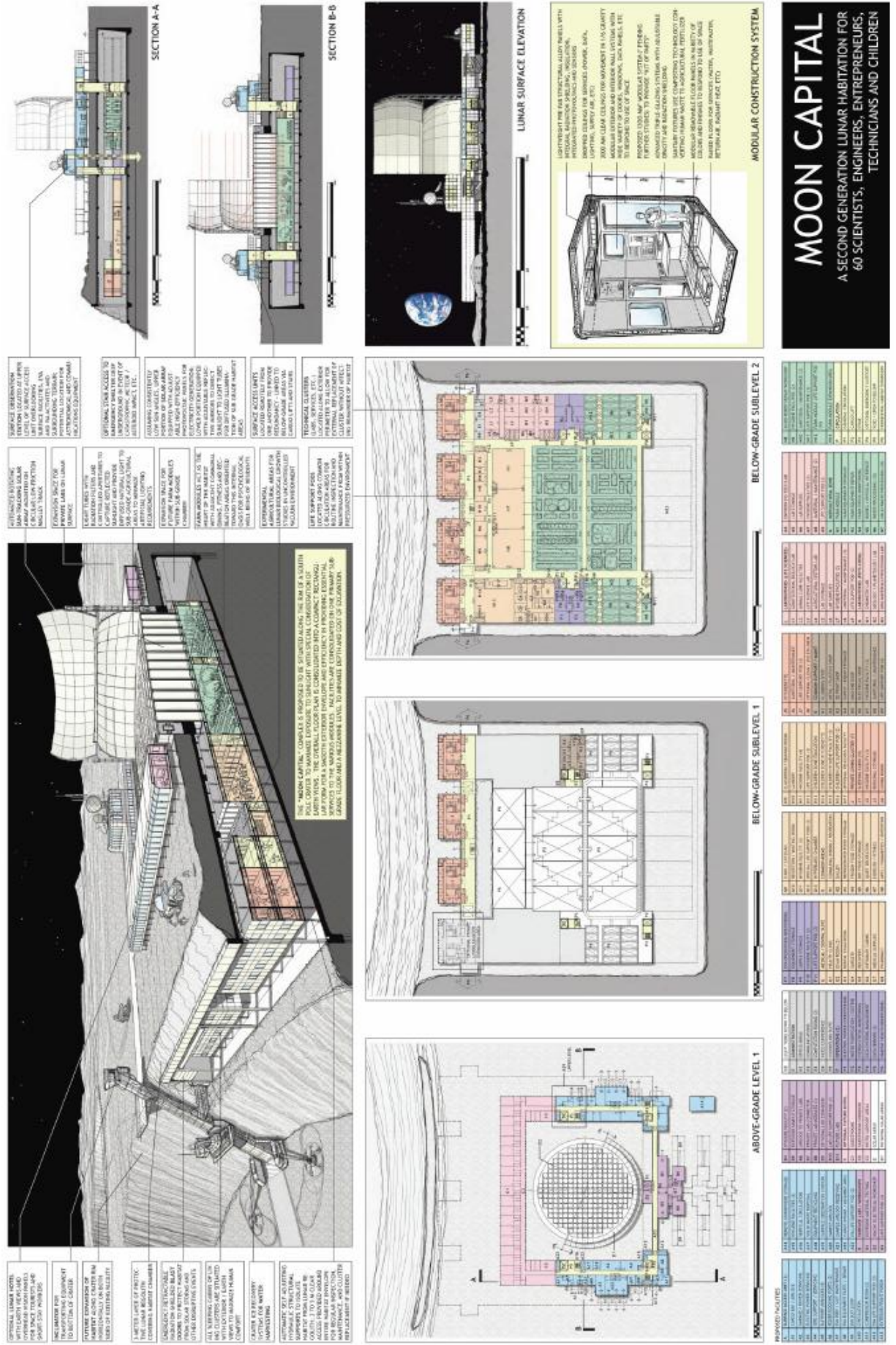

Figure 10 - Moon Capital

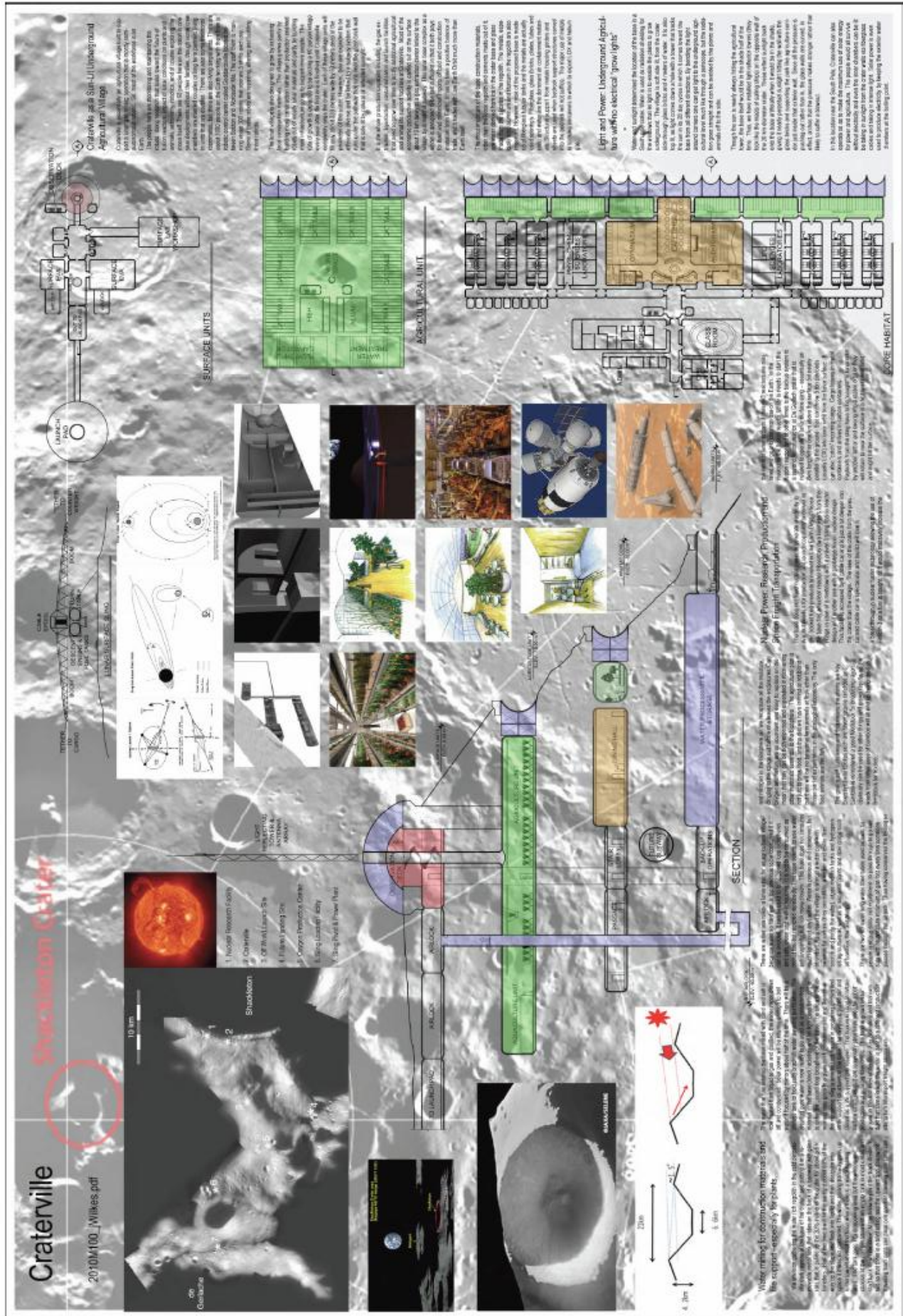

Figure 11 - Craterville

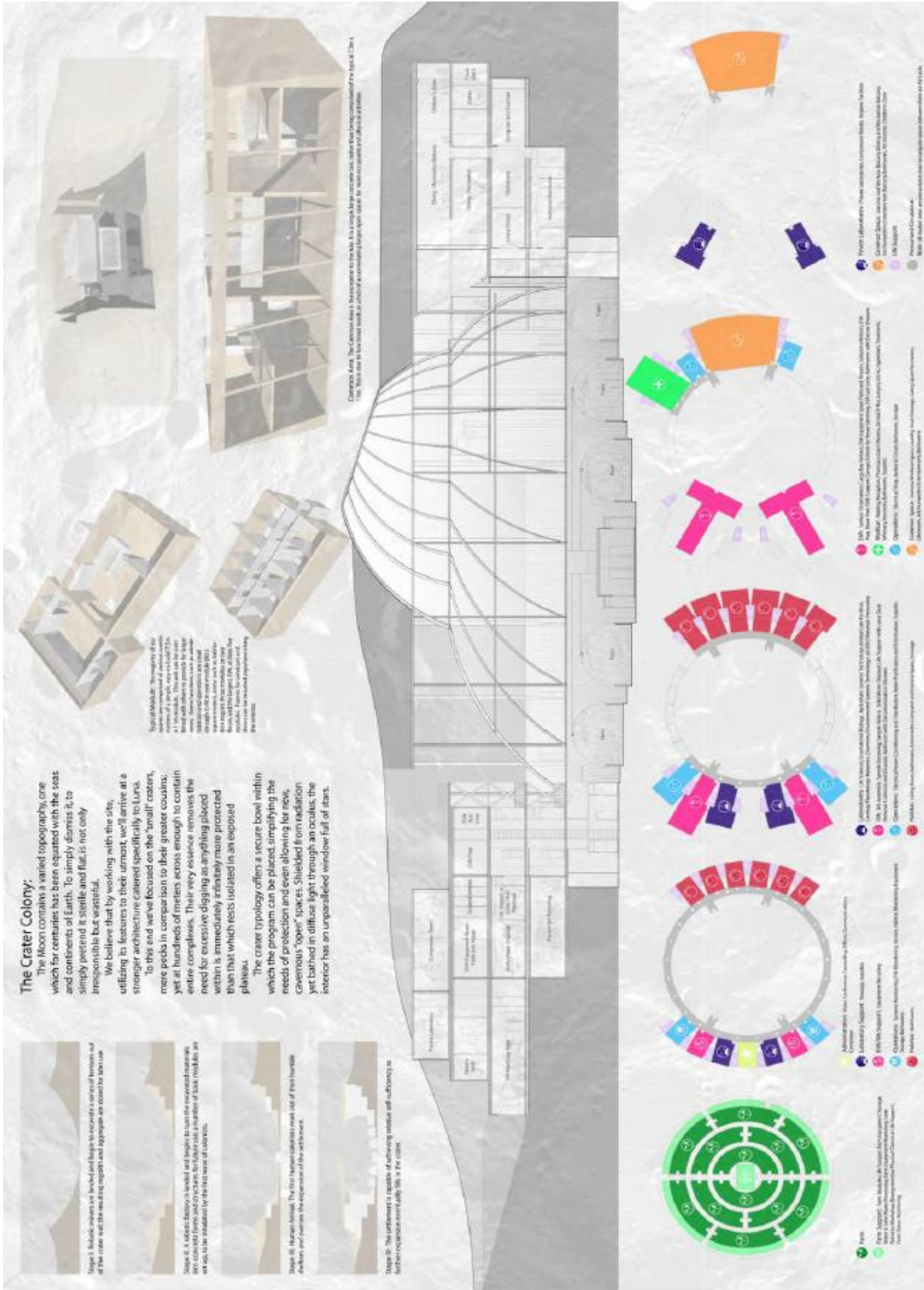

Figure 12 – The Crater Colony





# MoonCapital

home is where the sun always shines

### DESCRIPTION

Some people have specific career objectives, others like to live in the shade of a tree, and some want to be in the center of the world. The Moon Capital is a futuristic city designed to meet the needs of all these people. It is a place where you can find everything you need to live a happy and healthy life. The city is built on the Moon, and it is a place where you can find everything you need to live a happy and healthy life. The city is built on the Moon, and it is a place where you can find everything you need to live a happy and healthy life.

### IDEA

The idea of Moon Capital is to create a futuristic city on the Moon. The city is built on the Moon, and it is a place where you can find everything you need to live a happy and healthy life. The city is built on the Moon, and it is a place where you can find everything you need to live a happy and healthy life.

### FUNCTIONS

The functions of Moon Capital are to provide a place where you can live, work, and play. The city is built on the Moon, and it is a place where you can find everything you need to live a happy and healthy life. The city is built on the Moon, and it is a place where you can find everything you need to live a happy and healthy life.

### MAIN VIEWS

The main views of Moon Capital are the city from the ground, the city from space, and the city from the Moon. The city is built on the Moon, and it is a place where you can find everything you need to live a happy and healthy life. The city is built on the Moon, and it is a place where you can find everything you need to live a happy and healthy life.

### RENDERINGS

The renderings of Moon Capital show the city from different perspectives. The city is built on the Moon, and it is a place where you can find everything you need to live a happy and healthy life. The city is built on the Moon, and it is a place where you can find everything you need to live a happy and healthy life.

Figure 14 – Moon Capital

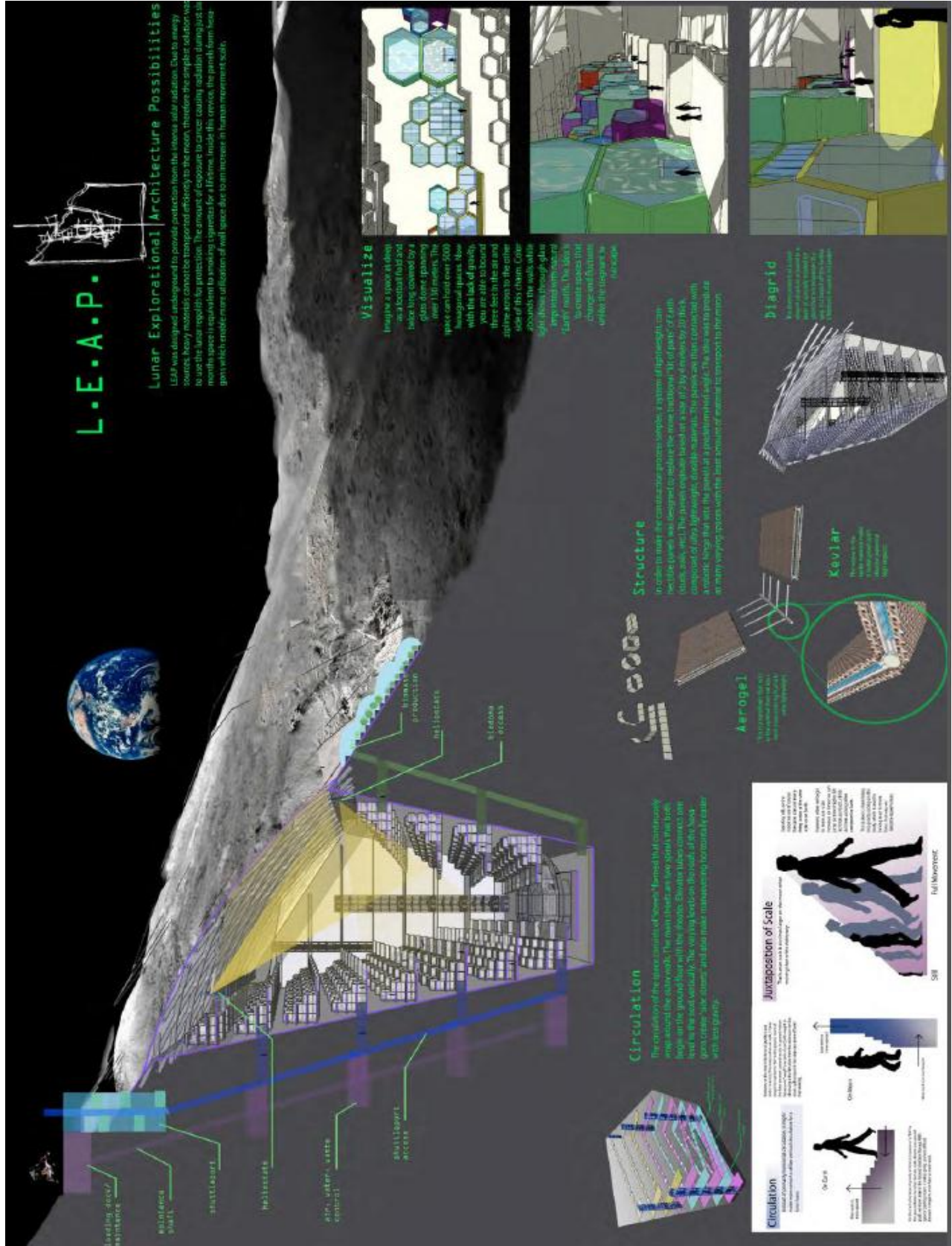

Figure 15 - LEAP



Figure 16 – Town Planning Mostyrando

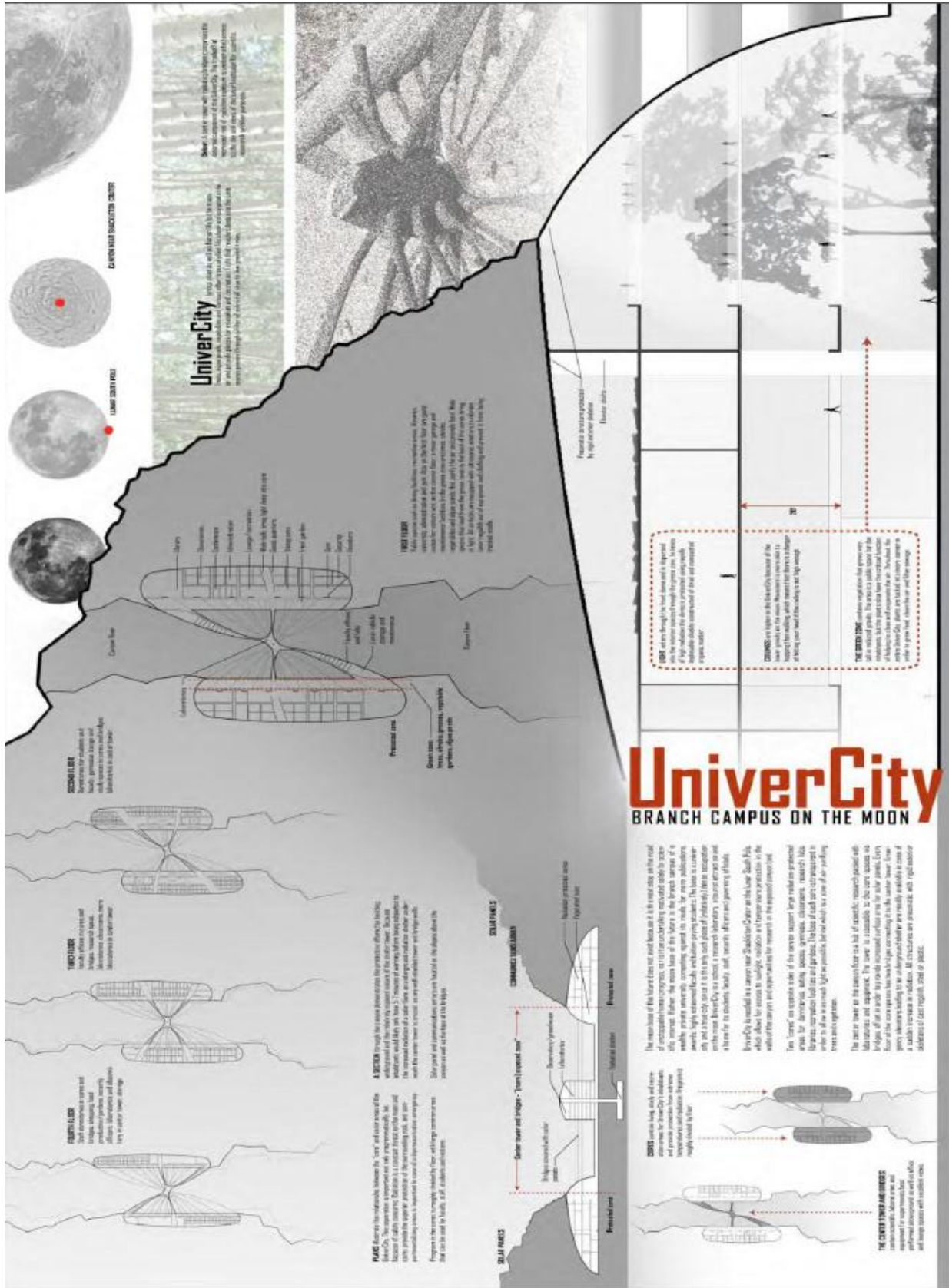

Figure 17 - UniverCity

# FORT RILLE: A VISION OF 2069

MOON CAPITAL Competition 2010

## STORAGE / LUNAR HOTELS



Nothing goes to waste on the Moon. From an lunar spent rocket stage to a piece of metal debris, all are preserved with dual risks. Some serve as the basis for long-term, pressurized supply storage, and others become self-contained lunar hotels. Attracting wealthy adventures, these "Dodge Iron" offer sleeping and dining quarters, entertainment, and security systems, and private abodes.

## POWER GENERATION



With the sun as an ever-present energy source, high-efficiency solar panels are used with great frequency at FORT RILLE. Also, as was the case with fire during industrialization, fear of radioactive elements as power sources is a thing of the past. This is a gas-powered bioelectric batteries are common. Due to their light weight, multichannel lithium, and meet conditions when "used up."

## SPIRIT OF DISCOVERY



From ridge-top telescopes like the one depicted at left, able to take lunar and inter-planetary photos, to the use of lunar geology and exploration performed on foot or by rover, the spirit of discovery permeates FORT RILLE. Nearly every day a resident or visiting scientist returns from the field to tell others about their newest discoveries.

## LUNAR OCCUPATIONS



In addition to infrastructure positions like communications and repair, and largely like-robotic one-earth-remote mining operations, FORT RILLE manufactures and exports a culture of its own. Well-off photographers, poets, musicians, and artists have all traveled to the Moon to push the envelope of their creative passion, share it, and deliver it back to Earth. Designers on Earth have even begun to copy the look of lunar utilization, incorporating the ubiquitous solar panel and pressure suit motifs into the latest trends.

## RADIATION PROTECTION



Surrounding the settlement is an array of large, spherical domes. Each generates a protective magnetic field, which neutralizes incoming particles from hazards and launch zones. Just like staying warm in winter on Earth, radiation-shielding is a way of life on the Moon.

## A LIFE ON THE EDGE

The above view is a depiction of FORT RILLE, a hypothetical 2069 lunar outpost in a crater near the Moon's southern pole, as it would be seen or approach and descent from three miles away. Owing much to the spirit of Werner Von Braun's Project Horizon, the concept of FORT RILLE is one of a growing number of lunar colonies that are being planned and equipped to the Moon well in advance of the first permanent lunar settlements. Consequently, the life-orbits men and women who occupy the first permanently occupied lunar settlements will have to deal with haste and alien realities and the very edge of our understanding and experience.

What sort of culture would emerge in such an environment?

The promise of a hard, killing life on a new world does the same thing: self-sufficient spirits that settled the world in the first place. For the first few years after their arrival, each would be a self-reliance in a sense of purpose. They are talking to the future.

### LUNAR FRONTIERSMAN

Backpacks and a radio, including the world's first lunar roving vehicle, are used to explore the lunar surface.



A sleek, lighter-duty "Mule" is used as a transport vehicle. It is a modified lunar rover that provides a means of transport for the FORT RILLE. The Mule is used to transport supplies and equipment to the lunar surface.

### REMOTE TELEROBOTS



The robot's human form allows workers to perform tasks that are too dangerous for humans. It is used to explore the lunar surface and to transport supplies. The robot is controlled from Earth via a radio link.

### TRUSTY STEED



Similar to the lunar "Mule," the Steed is a modified lunar rover that provides a means of transport for the FORT RILLE. It is used to transport supplies and equipment to the lunar surface.

## COMMUNITY CENTERS



Soft, heated, lined habitats provide the core community centers for FORT RILLE. Including advanced, a general store, club, school, and equipment shop, most structures stand their time here. Warm tones contrast the grayish lunar landscape. Much like the arctic ships and expeditions of centuries past, life is borne out of necessity. In the face of what would otherwise be the psychologically-prone reality of distance and physical isolation, work hours are maintained for one reason, allowing time to be spent with family and friends as frequent, and any chance is taken for celebration.

On the Lunar Frontier, Work hard, play hard.

## ROVING LIFEBOATS



Risks, increased, and consequently life-support from Earth, making "Mules" across the poles at the same time. FORT RILLE. Should an accident occur, these sturdy vehicles offer pressurized living space and supplies in the event of an accident, if someone becomes lost or overexposed, or if someone pushes their air supply a little too far before heading back.

Figure 18 – Fort Rille

# MOONBASE



FARM MODULE

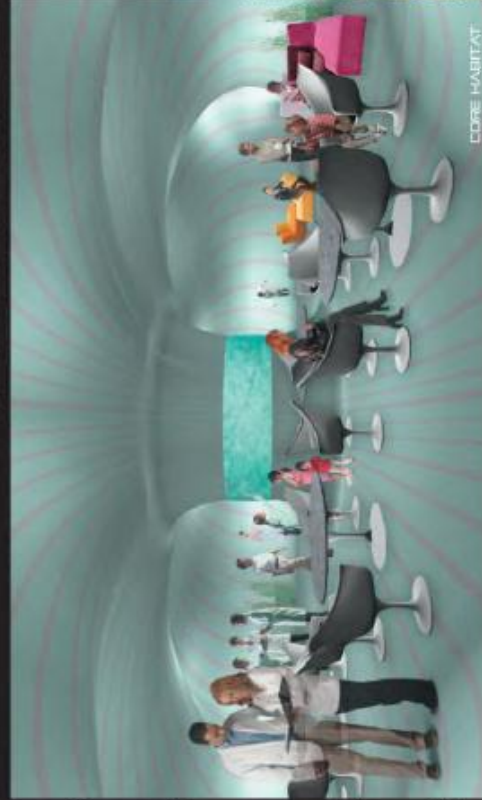

CORE HABITAT

**Energy** - Coming to a fully closed system. The Moonbase will have solar panels that generate power for the base. The solar panels will be mounted on the exterior of the base and will be connected to a power distribution system. The power distribution system will be a closed system that will store energy in batteries. The batteries will be used to power the base during the night. The solar panels will also be used to power the base during the day. The solar panels will be connected to a power distribution system that will store energy in batteries. The batteries will be used to power the base during the night. The solar panels will also be used to power the base during the day.

**Climate** - The Moonbase will have a climate control system that will keep the temperature at a constant level. The climate control system will be a closed system that will use a combination of solar panels and batteries to power the base. The climate control system will be used to keep the temperature at a constant level. The climate control system will be used to keep the temperature at a constant level. The climate control system will be used to keep the temperature at a constant level.

**Living Quarters and Recreation** - The Moonbase will have living quarters and recreation areas. The living quarters will be a closed system that will use a combination of solar panels and batteries to power the base. The recreation areas will be a closed system that will use a combination of solar panels and batteries to power the base. The living quarters will be used to keep the temperature at a constant level. The recreation areas will be used to keep the temperature at a constant level.



Figure 19 - Moonbase

## Origins of the USAF Space Program 1945-1956

### Chapter 1 - The Beginnings

...Konstantin Tsiolkovski (also Ziolkovsky) was a Russian, a teacher largely self-educated in physics and mathematics, who first mentioned the possibility of space flight in an 1895 article which, somewhat to his surprise, was accepted and published. By 1898 he had carefully refined his ideas on the subject-- which had fascinated him for perhaps 20 years-- and had arrived at a workable rocket theory involving liquid fuels based on kerosene, the only then-apparent means of producing the exhaust velocities he knew to be essential. He devoted another 25 years to further studies, with little or no experimentation, before receiving any general recognition. Even then, that recognition came because the Soviet state was interested in demonstrating that a native Russian had been the first to propound mathematical formulae for rocketry.

Tsiolkovski knew nothing of Ganswindt, and neither of the two pioneers who followed Tsiolkovski heard of him before their own work became rather well advanced. The creation of useful interest in rocketry-- and in space flight-- was the achievement of a German-- Hermann Oberth-- and an American-- Robert H. Goddard-- whose work was for practical purposes entirely independent of outside influences. Oberth was a theoretician, and Goddard, an experimenter. Oberth had space flight in mind from the start; Goddard was interested in rocketry almost as an end in itself. Oberth never succeeded in transforming his entirely sound concepts into a functioning rocket engine; Goddard did virtually no public theorizing until he had proven the validity of his concepts by demonstration. Goddard was a proponent and practitioner of pure research; with Oberth, the object of space flight far overbore considerations of science in the abstract. Goddard published only two significant items, and one of these was a 1919 paper which evoked enough public ridicule (because it gently suggested the theoretical feasibility of hitting the moon with a payload of flash powder) to cause its author deliberately to seek obscurity for 16



years. Oberth was more interested in obtaining support for his ideas than in proving or trying them, and he was entirely willing to employ such unprofessional media as pseudo-science motion pictures in the process. Goddard was the first man to build and successfully test a liquid-fuel rocket (November 1923), and by May 1935 had succeeded in sending a gyroscope-stabilized rocket to an altitude of 7,000 feet.

(The best of the pre-Peenemunde rockets created by the German research group that eventually developed the V-2 was much heavier but attained an altitude of only 6,500 feet in about the same time period.) Oberth's efforts resulted in the formation, in July 1927, of a German Society for Space Flight which promptly set about recruiting enthusiasts, seeking publicity, and collecting funds to support experimental work. Goddard carried his objections to publicity so far as to refuse to answer letters from such groups. In 1929 Oberth reworked his 1923 book, which had started the enthusiasm in Germany, and produced as a result the most authoritative of the early treatises on experimental rocketry. Goddard made no effort to circulate the results of his work until 1936, when it was largely complete (at least he carried it little further).

Indirectly, Goddard's work led to the formation of the Aerojet Engineering Company through the Guggenheim Foundation (Jet Propulsion Laboratory of the Guggenheim Aeronautical Laboratory at California Institute of Technology), the interest of Dr. Theodore von Karman, and Army Ordnance Department desires to use high altitude rockets to prove-out missile designs. Very much the same thing came from Oberth's efforts, which led with similar indirection to German Army sponsorship of the experimental work being conducted by the "Society for Space Flight." The Wehrmacht, of course, was not interested in space flight but was very much interested in long range artillery that did not come under the ban of the Treaty of Versailles. As it happened, that treaty became inconsequential shortly after the German Society for Space Flight did the same; Hitler's seizure of power in January 1933 coincided with the start of Army-funded rocket research, and the indifferently concealed rearmament of

Germany thereafter obviated the need for any particular disguise. By that time, however, the well financed experiments had been transferred to Peenemunde, on the Baltic coast, and had produced results which encouraged the Wehrmacht to continue research toward the objective of a long range bombardment rocket. Wernher von Braun, a boyish latecomer to the Society for Space Flight, became the principal civilian manager of the Peenemunde work and converted to his way of thinking--that missiles were a step toward space flight, not an end in themselves--the unlikely figure of the military chief, Captain (later Lieutenant General) Walter Dornberger. With resources that at one time accounted for at least one third of Germany's entire aerodynamic and technological research establishment, they moved with relative rapidity from the primitive rockets of 1933 to the operationally ready V-2 bombardment missiles of 1943. Development of the V-2, or properly the A-4, began during the winter of 1938-1939 as the climax of five years of applied research. The first successful operational prototype, and the third test vehicle in the series, completed a field trial on 2 October 1942; more than 100 production versions were tested in Poland in the early months of 1943. The first combat firing at London came on 8 September 1944, and by March of the following year more than 1,300 V-2's had followed the first to England.

Unfortunately, from the standpoint of the scientist and the space flight enthusiast, concentration of attention on bombardment missiles neatly eliminated serious work on space research. At least four people (Tsiolkovski, Oberth, Goddard, and Dr. Walter Hohmann of Hamburg) had worked out perfectly valid data on exhaust velocities, mass ratios, and trajectories before 1930. The decade of the 30's was spent in carrying rocket technology to the point of practical application, and during the first half of the 40's, rocket technology was applied to the art of war. There were some few exceptions, concentrated largely in Germany, where the only propulsion systems with sufficiently high thrust to promise eventual space applications were being perfected. Walter Dornberger recalled several years after the fact that "our aim from the beginning was to reach infinite space, and for this we needed speeds hitherto

undreamed of. Range and velocity were the great landmarks that guided our thoughts and actions." In another context he remarked, "With our big rocket motors and step rockets we could build space ships which would circle the earth like moons. Space stations . . . could be put into orbit around the earth. An expedition to the moon was a popular topic too."

## Proposal to the City of Worcester

### Introduction

One of the buildings currently included in the North Main Economic Development Strategy is the Worcester Auditorium. In its prime, this magnificent building was used as a multi-purpose hall. It is also a World War I Memorial. Its large floor and stage are surrounded by numerous balconies, which can seat thousands. Now, however, the building is mostly unoccupied and serves only to house Massachusetts State Trial Court records. The acoustics are not good enough for stage or music and there are other better places for these arts in the city, such as Mechanics Hall and the Hanover Theater. It is not going to be renovated if it is a potential competitor to the Centrum or the struggling Train Station renovation projects.

In addition to the large first floor, the Auditorium also has an expansive basement, which is also underutilized. Since the basement area was used by the Juvenile Court, most of this space is finished as office offices, with long corridors and drop ceilings and is in reasonably good condition. While it may seem counterintuitive, it is this basement that would be the best location for a special educational exhibit. Hence, we propose that the Auditorium be devoted to the cause of celebrating science and technology, past and future, but not as a museum.

This should be the site of a forward looking exhibit of immediate and high interest to both the public schools and many colleges of Worcester. As we enter a new Age of Discovery involving the emerging technology of space flight and try to envision what life in the moon colony in this century and another one on Mars in the next century might be like there as a wonderful opportunity to foster science education in the city that was home to Robert Goddard.

Further, a special opportunity to take part in an architectural competition has arisen that will allow Worcester to try this idea on for size at little to no cost. Tours for the architects entering the

competition over the coming summer are really all that will be needed and the AIAA New England will provide the workshops on the lunar environment that they will need at no cost to the City. Others will even put up the prize money. A noted local architect wants to enter the competition and will specifically work up designs for the Worcester Auditorium if used in this way.

We strongly urge the City to co-sponsor this upcoming architectural competition with SHIFTBoston and AIAA NE to design a simulated lunar base to be built in the basement of an underutilized public building. Its role would be to offer the specifications for this building to any architect who wants to use them to enter this contest to be held August –December 2011 and have a specified time each week that people associated with the contest can have a tour of the building.

The city of Worcester should also participate in judging the resulting designs and set up to do its own independent review of them. The ideal time to announce the contest would be April 12, 2011- which is the 50<sup>th</sup> Anniversary of Yuri Gagarin's first human space flight into space. This was the event that galvanized the USA into action to go on to win the space race to the moon. So, with a glance back 50 years we will look 50 years to the future when a lunar base will exist, and try to envision today what it will look like to inspire our youth to be the ones the design and build a lunar base than can feed itself and pay for itself. That will make a major milestone in the emergence of a new industry that would be a very nice thing to have grow up honoring the visionaries and pioneers from Worcester, Mass who made it possible.

### **The Lunar Base Exhibit**

We propose that the basement space of the Worcester Auditorium be redeveloped to serve as the location of a semi-permanent educational lunar base exhibit. By this we mean that the area would not be structurally altered so that it could not later be vacated for another use. This exhibit would be constructed to accurately depict living conditions on the Moon, in which visitors could explore the

possibility of living on the Moon, see and hopefully interact with the latest space technology that would make such a feat possible. This technology might include: water recycling, hydroponics, robotics, and the processing of regolith to produce glass, metal, and liquid oxygen. The learning experience that could be offered at such a place would be astounding, as indicated by reactions to a recent event at WPI for 5<sup>th</sup> graders. They were thrilled just to see architectural drawings of a lunar base that was a fully functioning biosphere. We are confident that no exhibits in the northeast U.S. are designed to do what this one plans. Most of the potential planned competitors are in Florida or California and deal with a Mars base.

The proposed exhibit would be designed and constructed as part of a larger project to introduce a space-enriched science and technology unit into the Worcester Public School System science curriculum. Students would spend about a month learning about space in the classroom through a “spiral” curriculum that covered all the same concepts in their text, but in a different way. Then there would be a capstone experience to put all that information to use as, they would also be able to visit the lunar base exhibit. The visits should be scheduled on an annual basis to help them visualize the possibilities. Each year the thematic subjects would change and thus the activities would be utterly different for a 5<sup>th</sup>, 6<sup>th</sup> or 7<sup>th</sup> grader. From a focus on the greenhouse one year, to running robots that extract oxygen and metal from the rocks the next year, to going on a surface geology expedition the next each trip will encourage learning as well as inspire young 5<sup>th</sup> grade to 10<sup>th</sup> grade students to learn. By comparing the moon and Earth, they will come to understand why these two bodies are so complimentary. These differences will be the basis for the first trade system in space, and that will create the wealth to move out into the rest of the solar system for the first space faring societies. A New Age of Discovery is upon us. The next generation of space visionaries needs to be trained to lead us into it, and it seems right and proper that Worcester should be the place to build on the legacy of Robert Goddard.

It is critically important to encourage this type of learning in younger students, starting with 5<sup>th</sup> graders. This is the group that will be 39-40 (astronaut age) in 30 years when lunar and Martian exploration projects will be in full swing. As the space industry progresses, there will be a demand for young people to take on the challenge of developing space technologies, and working on projects related to the economic development and eventual colonization of space. If these children can be exposed at such a young age to the excitement and challenge that comes with science applied to living and working in space, and economic initiatives, Worcester would be able to provide the country (and the world) with top entrepreneurs, scientists, and engineers in this emerging field for generations to come.

As previously mentioned, this “spiral” curriculum would allow students to learn new concepts in a wide range of fields in a setting that would constantly relate back to a single integrating theme: a permanent lunar base initially designed for 60 people, but able to expand to over 6000 in the next 100 years. Upon further consideration, it is clear that a lunar base theme is amazingly versatile and fully interdisciplinary. Nearly every field of science, from basic astronomy, physics, geology, chemistry, and biology, ecology, physiology, civil and chemical engineering, robotics, and agriculture has a role to play. Extensive research and groundwork needs to be done in each of these fields in order to produce a successful lunar base and later economically viable colony. Each year, students would begin by studying a new topic as it relates to constructing and operating a lunar gas mining facility and nearby agricultural village habitat. As the students progress in their education, they continue to learn new science topics in a way that also teaches them about the challenges of living and working in space. Many of these lessons can translate to a better life on Earth, including cultivating deserts and recycling everything seamlessly.

The idea of a spiral curriculum meshes very well with the concept of a lunar base exhibit. During their visit, the students would be able to explore specially-designed hands- on interactive stations that

would solidify their classroom learning. Since this exhibit would be designed in conjunction with the curriculum, the bridge between classroom learning and the exhibit would be easy to navigate. The advantage of the spiral curriculum is that the subjects taught would change each year. Current science enrichment activities are too scattered in theme and topic to build toward anything memorable or justify repeated visits to a single facility. This combination of exhibit and thematic curriculum provides a method of learning that covers a large spectrum of topics and far surpasses the likely learning outcomes of traditional science education programs. Further, the AIAA- New England a professional society chapter with 850 profession members 150 college student members and 50 K-12 educators is fully prepared to support an effort to put Aerospace back in to the science curriculum, and will take a special interest in both the exhibit and the science curriculum that amplifies its value. About half of that membership is in the Boston, Worcester, Lowell (Metrowest) triangle and is really right in commuting distance and able to make a difference for the local science education effort.

### **The Competition**

While designing and construction this lunar base exhibit may seem like a daunting task at first, there are many forms of support that will combine to produce a properly designed, funded, and maintained lunar base exhibit.

In the summer of 2010, an organization from Boston, MA called SHIFTBoston hosted a design competition. The goal of the competition was to design a “second generation” lunar base, circa 2069. In response, SHIFTBoston received 102 entries from architects and a few scientists from all over the world. This tremendous interest in the Moon came as a surprise consequence of the recent discovery of water ice on the moon. This wave of interest can be leveraged to help support the lunar base exhibit concept. AIAA New England co-sponsored the event and asked us to evaluate the entries on the basis of technological feasibility and elegance to honor the designs that could “work” with a special prize separate from the one the architects bestowed for dramatic artistic vision .



As part of our research, we have worked closely with Kim Poliquin, executive director of SHIFTBoston, to discuss the results and potential future of collaboration of AIAA NE with SHIFTBoston. Since there was such a deep interest in the moon for the last competition, Kim is working on designing another lunar-based competition. Instead of designing a lunar base for construction on the Moon we proposed to her that the goal of this competition would be to design a lunar base “science” exhibit for construction an abandoned and underdeveloped building in a city. She has accepted this proposal and endorsed it. Hence, the search is on for a suitable site to use so that the architects are all working with the same or similar space constraints as they try to evoke an exalting image of life in an alien environment in a dank cavernous basement of a public building. If the Worcester Auditorium were offered up as a possible location, the results of this competition could be directly converted into a contract to work up the details to actually construct a lunar base exhibit in Worcester. This would aid greatly in letting people visualize the possibilities, as well as save the city the need to pay for an architect to work up a concept drawing. Worcester would likely have 50 or more good ones to choose from on a first cut evaluation. The only question is whether the renovation of the first floor to be used as a multipurpose area should be part of the competition? Kim of SHIFTBoston seems to think that they would have the whole building to work with but the city can specify what range of uses it has in mind for each area.

A very important part of hosting this competition is going to be setting forth the rules and guidelines in order to ensure that nearly all entries are viable candidates for an actual exhibit. In order to make sure that the winner of the contest will be educationally accurate and able to be built, the designer needs to be presented with three main components: 1) a detailed description of the minimum contents of the lunar base exhibit, 2) a fully-developed depiction of what an actual base on the moon will look like, and 3) a location for which the exhibit could be designed for. The first requirement is one of the most critical portions of the requirements, since a valid design must include detailed, accurate,

and complete descriptions of all the topics in the curriculum in a way that can be demonstrated in the context of a lunar base. To this end, extensive research has been done into the desirable features of a lunar base design based on the entries of the first Moon Capital Competition. Additionally, various WPI student teams have been working on the idea of a lunar base for the last 5 years. WE can handle that part in time for a competition to be run August to December of 2011.

As part of our WPI Interactive Qualifying Project, we have been able to obtain access to 89 of the entries to the original SHIFTBoston competition. We then analyzed these architectural posters with a very important, but originally neglected set of criteria that evaluated how technically feasible the design was. The result of this analysis was about 15-17 poster entries that employed concepts that are scientifically accurate and feasible (considering the 2070 technology timeframe). The best ten of these posters and our accompanying analyses were presented to a wide range of audiences to obtain feedback regarding what concepts will work. The audiences ranged from AIAA NE professional chapter members, to the AIAA student chapter at WPI gathered at a Pugwash organization event at WPI. Interestingly, we also presented to an audience of 5<sup>th</sup> grade students and teachers that numbered just under 400. The combined results of our analysis and this feedback resulted in a design concept for a lunar base that incorporated all of the best concepts from each of the top Moon Capital entries. This design concept has been present to SHIFTBoston and will serve as a guide for the upcoming competition.

The next critical piece required to host this lunar base exhibit design competition is a location. Several options on how to present a location have been considered. One of these options is to develop a list of criteria that any lunar base exhibit location would need to have. For example, the exhibit would need to be located in a city of at least 100,000 in order to justify the costs, as well as to ensure that there would be a sizable audience of students that would be visiting the exhibit on a regular basis. In

order to justify the costs associated with building and maintaining the exhibit, there would have to be enough students nearby to generate positive net income based on \$100/ class of 20 students to visit the exhibit on a field trip. Based on the criteria set forth in the contest guidelines, entrants would be able to design the exhibit for any location that fits the description.

While this surely would result in a feasible lunar base exhibit design, it would not be ideal. While many cities have abandoned or underutilized buildings, the looming question remains as to whether or not the city planning organizations would be willing to offer up the building to be used for an educational purpose. The ideal situation would be to provide the entrants with detailed specifications of a building that is currently underutilized in which they could design their exhibit, and most importantly, where the education committees and administrators would seriously consider the case for having a local lunar base exhibit. After the competition is over, the entrants would be analyzed for educational completeness and economic feasibility, and the winner would be presented with a contract to design detailed construction plans for the exhibit, if the decision is to go ahead with the project.

### **The Ideal Location**

After much consideration and research, we determined that Worcester would be the ideal location for such an educational exhibit. There are several factors that make this an ideal location, including the size of the public school system, the proximity to several colleges, and central location in New England relative to Boston as well as Springfield, Hartford, Lawrence, Lowell, Nashua, Concord, Manchester, Providence and Framingham all of which could send field trip students this far on a day trip. In the case of Framingham, Concord and Hartford (actually Windsor, Ct) there are aerospace exhibit of some interest to Worcester students and a fee trade or cancelling arrangement and bus sharing could be considered. However, only the Airplane museum in Connecticut will equal what we have in mind for Worcester.

Worcester's extensive public school system would provide thousands of students with a unique opportunity to explore space and study science. In the 2010-11 academic year, over 6,650 students attended Worcester public schools. While this number encompasses all grades, the spiral curriculum would reach a large number of these students right from the start. Currently, science field trips are rare, due to the substantial costs associated with travel and admission. For example, a field trip sponsored by the AIAA New England for 42 fifth grade students to the New England Air Museum in Windsor Locks, CT costs about \$1200, not including lunch. This breaks down to \$800 for admission and \$400 for the bus transportation. This lunar base exhibit would provide an affordable, local, learning solution outside the classroom for thousands of Worcester students for years to come.

Another important aspect of Worcester's attraction is the number of colleges and universities in the area. The Colleges of Worcester Consortium includes thirteen member schools, including Worcester Polytechnic Institute, one of the premier science and technology schools in the northeast. While this lunar base exhibit would not directly serve the students of all of these schools, their students could play a very important role in supporting the exhibit. The largely interdisciplinary nature of the exhibit would provide students from any of the area colleges an opportunity to participate in the design, maintenance, and operation of the exhibit. Through volunteer work, for-credit course work, or possibly even work-study, students would be able to visit the exhibit and work to design the exhibit (in the initial stage of the project, and later in keeping the exhibit accurate and up to date), maintain the exhibit through construction projects, artistic work, or media creation, and operate the exhibit by means of student tours and staffing. The involvement of students from any and all of these schools would be encouraged as a unique opportunity to learn about space colonization in a way that encourages younger generations to do the same. With a new interdisciplinary minor in space studies, offered through the COWC students would be able to distinguish themselves and increase their chances of employment in the aerospace industry. Especially exciting would the potential to give students studying to be elementary and middle

school teachers a chance to see how science education really should be done and develop a strength in this area that will serve them well where ever they go. The WPS will of course get first crack at them to do internships and recruit those with a gift for this kind of beyond the textbook science education.

In addition to each of those great benefits, the lunar base exhibit would also allow students from outside of Worcester to reap the benefits of a standard educational field trip. Currently, many space science-based field trips necessitate a long trip to the New England Air Museum in Windsor Locks, CT (1.25 hours from Worcester, 2 hours from Boston) or the McAuliffe-Shepard Discovery Center in Concord, NH (1.3 hours from Boston, 1.6 hours from Worcester). Clearly, Worcester and Boston school are disadvantaged in their access to space science education centers, even though the Boston Science Museum provides a more comprehensive science education experience. There is also the McAuliffe Center in Framingham, MA, which costs \$400 for 24-36 students to go on a simulated trip to Mars which lasts three hours. Transportation costs and food add more than \$250 in additional costs. They want you to stay to see the Planetarium show too and jacks the price up to \$600. The proposed Worcester Auditorium exhibit would give Boston schools access to the exhibit with only an hour's bus ride, and a trade balance between Worcester (space base ) and Boston ( science museum) field trips would be established allowing many more students to do both.

This close access to a great number of schools nearby would also provide the exhibit (and Worcester) a unique opportunity to generate revenue for the renovations required for the main floor of the Auditorium. It has been estimated that the required renovations would cost the city about \$30 million, which the city cannot currently justify. While the schools would be charged a nominal fee (about \$100/class or \$5/student) for their attendance, the cost is small compared to current options for a field trip. Since the transportation costs would be lower, thanks to the central location, these school districts would be able to afford more trips to send more of their students for the day. If the exhibit is as popular

as expected, the funds necessary to renovate the building and maintain the attractiveness of the exhibit would be generated. Further, once there is a revenue stream, financing the other upgrades to take full advantage of the stream of visitors is possible. Exhibits typically offer supporting services and souvenirs, hence, letting business set up booths and rent space on the main floor would be a reasonable development that would justify a modest investment to prepare the main floor space for this use.

In addition to the geographic benefits of the lunar base being situated in Worcester, there are other benefits to locating the exhibit in the Auditorium specifically. One, the public schools are interested in improving science education, want to partner with WPI and other colleges to do it, and the recent event at WPI offers a reasonable model for doing so. A curriculum integration strategy makes sense and if the colleges are willing to conceive of and operate a science exhibit for the public schools a lot of student can meet their need for public service projects to justify their federally funded educational grants and work study jobs.

### Availability of the Proposed Site

Charrette is a term often used to describe a meeting of developers, planners, and residents to decide on a course of action for urban redevelopment. These meetings often include the proposal of several ideas for new construction projects, or the redesign of existing structures for a new purpose. Worcester has held several Charrettes over the years about Lincoln Square and especially the Worcester Auditorium. Charrettes can provide innovative and successful ideas for the good of the city and its residents- however, this building has stumped the architect planners and citizens who have come to the Charrettes like. It is just no suitable for private redevelopment and the city wants to get out of the cost of maintaining it. Currently, the city of Worcester, Massachusetts is looking to develop and revitalize the underutilized Lincoln Square/North Main Street area. The city has assembled an Economic Development Strategy team to conduct research and host a forum for potential development plans for the area. The

Worcester Auditorium is considered the “White Elephant” in this area, the gem that is very difficult to figure out how to reuse. Part of the problem is a lack of parking as it clearly is designed to handle public gatherings. We think that a core audience that arrived by bus, leaves by bus and the busses do not all have to hang around and wait for their travelers is ideal for this space.

To serve the students of the Worcester Public Schools about 400 at a time involves about 18-20 classes coming from about 8 schools. We test drove such an event at WPI on Jan 26<sup>th</sup> and found that none of the buses wanted a place to park. They just dropped off at 9:00AM and picked up at 1:30PM. This is ideal for the Auditorium, though about 5 buses could be handled near the building if they came from another city and wanted to stay parked for the day. Framingham State gets by with 1- 2 bus parking spaces but they can handle only 36 at a time, and only have two when they overlap as one group is coming and the other is going. Given nearby Gateway Park Worcester could handle many more busses as long as they left the pickup area for most of the day. On a day that was open to the public people could park their cars a few blocks away and be shuttle bussed to the Auditorium for a modest fee that was part of the cost of parking for the event.

The North Main Economic Development Strategy includes the Worcester Auditorium but we think the plan is flawed because it considers each building a separate site to be redeveloped. Instead we think the strategy should be to develop them all around the theme created by the most magnificent buildings in the mix. These are the Auditorium, the Courthouse and maybe the Boys Club buildings- all tightly packed on Lincoln Square. Once in a century will the opportunity to rethink an area like this might come up. In its prime, the auditorium building ( which is at base in the public trust) was used as a multi-purpose hall, as well as being a World War I Memorial. Its large floor and stage are surrounded by numerous balconies, which can seat thousands. Now, however, the building is mostly unoccupied and serves only to house Massachusetts State Trial Court records.

In addition to the large first floor, the Auditorium also has an expansive basement, which is also underutilized. Since the basement area was used by the Juvenile Court, most of this space is finished as office offices, with long corridors and drop ceilings and is in reasonably good condition. While it may seem counterintuitive, it is this basement that would be the best location for a special educational exhibit. The main floor would work better as either a museum or a multipurpose hall. The room upstairs with the wonderful mural probably should become a classy meeting space where food can be served. We would love to see a memorial to Robert Goddard somewhere in the building- possibly with a World War 1 vintage Airplane to indicate what he could see as existing technology as he imaging a way to get to the moon and beyond.

The Courthouse seems to be easily convertible into academic space, classes, library and offices. The Boys club is more flexible, but it too could be academic with a few good class spaces and mostly cubicles or laboratories, possible of the kind a startup business would want- possible part of a college program based in the old court house or conceivably a business incubator.

If there were a world class space exhibit in the Auditorium and exhibition space on the first floor, and a major stage in multiuse space the college that would want to be next door would be the New England Space University or the American branch campus of the International Space University. ISU is in France, and its specialty is the training of the future administrators of national space agencies. It currently has no permanent campus, and is opening a branch in Australia. A major advantage of its being in Worcester would be the opportunity to piggyback on other existing college programs and cross list existing classes. Of course, the Court house building belongs to the State of Mass which would have to issue ISU the invitation to come with the understanding that it would have to renovate the building that it would get for free. Whether a nearby building would become the associated Space Law school is



a question that would have to be addressed. The School of Space Medicine would probably end up at the U Mass. campus with a shuttle bus to get people back and forth. The management majors at ISU could walk to WPI to get their technical courses and they would do their own space literacy program that would be open to majors of all the other colleges in Worcester, probably as a minor they could take if interested. This would be a unique draw for students to attend Worcester colleges from all over the World. It is likely that the ISU and WPI students would be able to run the exhibit between them, but there is no reason to exclude the students in other colleges if all it takes is a few regularly scheduled bus routes so that they can get there from any college in Worcester on the hour.

This is really a fine opportunity for Worcester to position itself for the future and improve public education as well as get a potentially very interesting tourist draw open in the summers when the public schools students are not coming to the exhibit and it is open for use as part of summer camp, youth club events, special trade show expositions and professional meetings in the field of Aerospace.

It is very likely that the architectural community would be inspired by the possibilities not only in the Auditorium itself, but what you could do with the space theme and the Goddard legacy to make this part of the city a special place indeed. The Worcester Auditorium is located in the North Main Street area called Lincoln Square, an entire region that is currently under review for redevelopment. In this square, there are 3-4 abandoned buildings and some 8-10 buildings in this area that are currently underutilized and looking to be restored to use. This provides a unique opportunity for the lunar base exhibit to anchor a redevelopment project that is not just an educational center, but a business incubator and an opportunity for many kinds of support and craft companies. Support offices and adjoining exhibits, classrooms, artistic exhibits and an annual festival could transform the North Main Street Square into a science education destination for the entire New England Region, and attract other national business and educational conferences to the city as well.

## Current Support

Throughout our development of this project, we have garnered support of several influential people. Notable figures include architect Dan Benoit, who has worked with the City of Worcester in the past, on the City Center redesign project. Dan was involved from the start of our project. He participated on one of the winning teams (for technical elegance) in the original Moon Capital Competition sponsored by SHIFTBoston over the summer. Dan has been busy moving his office this last term, but was a great asset to the project through his encouragement of us to work through this idea of a case for a lunar base exhibit. Given his knowledge of city politics and previous experience with executing large-scale construction projects, if he did not consider the idea crazy, there was hope for us.

We have also reached out to, and gained support from, Worcester Public School teachers and students as well as a membersof the current Worcester School Committee. In January, we presented at an MCAS review day, hosted at the WPI campus. While this event was hosted by another IQP team ( the one developing the 5<sup>th</sup> grade curriculum unit) , our exhibit design team was asked to present the results of the SHIFTBoston competition and the idea of a lunar base exhibit to hundreds of students and teachers. During the event, we were approached by School Committee Member John Monfredo, who commended our efforts and agreed that a lunar base exhibit would be an exciting opportunity for Worcester. After the event, we received numerous compliments and accolades. Here is a selection of the responses:

**Thank you so much! The program yesterday was great - kids and teachers loved it and really enjoyed being on a college campus. It gives them so much to talk about now. Your WPI students were wonderful. Please let me know if you would consider doing this next year and we can form a planning committee.**

**Kathy Berube, Science Coordinator, Worcester Public Schools**

---

***My children were thrilled. Herlin came to me at dismissal saying, "I went to the moon, Miss, I went to the moon!" Hasel could not believe the school [WPI] and wants to know if college is really like that because NOW she is interested in working hard to attend. Linette and Miranda also were so excited about what they saw and how WPI connects to our school-wide theme of wonder. I could go on and on but the proof is from the students. It was a success.***

***Marion Guerra, Principal, Goddard School***

---

The very positive feedback from nearly every school principal and teacher involved is proof of the enormous impact that an exhibit like this could have on the students and teachers involved. During the lunar base Design Review presentation, one student asked if we were going to build a model of one of the designs. We then told him and the rest of the class that we wanted to see an entire exhibit of one built. When prompted with the question, "If there was an exhibit like this, who would be interested in going on a field trip there?" every student and teacher answered with a resounding "yes." If a semi-permanent lunar base exhibit were to be built, opportunities for students to go "to the moon" could happen on a daily basis during the school year for one or another class in Worcester.

## **Conclusion**

In conclusion, this project has truly opened our eyes to the possibilities and it is our goal to open the eyes of others with this report. Although idea of a lunar base seems something of a futuristic possibility, we learned that within ten years that this could be a true happening. We came to this amazing realization after looking at the SHIFTBoston entries and narrowing down the finalist. Being able to look at the finalists we noticed that the technology they used in their moon bases was technology readily available today. This is shown in all of the finalists and honorable mentions discussed in this

paper. This always helps make the case for returning to the moon before China does, which is believed to occur in approximately ten years. Seeing how these entries were technologically feasible today is a huge reason to push for more aerospace subjects being taught in elementary and middle school levels, along with an exhibit to enhance their learning. It also will help to narrow the disadvantage we have here in America in the education system compared that of a country like China.

We also noted that an investment in a lunar base while although costly in the beginning, will in fact, if done correctly, pay for itself after years. This is a much better thing than say the canceled NASA project Constellation, which was to build a lunar base, but this was to be non-permanent, as it was a 'stepping stone' for a Mars project. A project like this would cost millions in dollars, all for a project that would be used for only a couple of decades. However, a project like the one discussed here would be beneficial in that a permanent base would be able to be turned into a self-sustaining base by using naturally occurring sources on the moon such as  $H_2$  or using the moon's regolith to form a cement structure or using plants to filter both the air and water. This was seen possible in a few of the entries that we saw. The key for being self-sustaining is to use the resources on the moon that has been mentioned in the above paper.

With the acceptance of this proposal, the City of Worcester will get a chance to transform the most magnificent and building in the Lincoln Square area into an engine of progressive change for the whole North Main Street area. This could and should be the site of a cutting edge space science educational facility to benefit students for generations to come. This is a great opportunity to continue Worcester's claim to fame as the home of the pioneer of modern rocketry, Robert Goddard, whose legacy is so important to South High, Worcester Polytechnic Institute, and Clark University among others.



## References

Wikipedia contributors. "Charrette." Wikipedia, The Free Encyclopedia. Wikipedia, The Free Encyclopedia, 20 Dec. 2010. Web. 16 Feb. 2011.

<http://www.vhb.com/northmain/>

Wikipedia contributors. "Worcester Memorial Auditorium." Wikipedia, The Free Encyclopedia. Wikipedia, The Free Encyclopedia, 17 Sep. 2010. Web. 16 Feb. 2011.

[http://www.worcesterk12.com/media/2011\\_Basic\\_Facts.pdf](http://www.worcesterk12.com/media/2011_Basic_Facts.pdf)

## ORIGINS OF THE USAF SPACE PROGRAM 1945-1956

### CHAPTER 1 - THE BEGINNINGS

...Konstantin Tsiolkovski (also Ziolkovsky) was a Russian, a teacher largely self-educated in physics and mathematics, who first mentioned the possibility of space flight in an 1895 article which, somewhat to his surprise, was accepted and published. By 1898 he had carefully refined his ideas on the subject-- which had fascinated him for perhaps 20 years-- and had arrived at a workable rocket theory involving liquid fuels based on kerosene, the only then-apparent means of producing the exhaust velocities he knew to be essential. He devoted another 25 years to further studies, with little or no experimentation, before receiving any general recognition. Even then, that recognition came because the Soviet state was interested in demonstrating that a native Russian had been the first to propound mathematical formulae for rocketry.

Tsiolkovski knew nothing of Ganswindt, and neither of the two pioneers who followed Tsiolkovski heard of him before their own work became rather well advanced. The creation of useful interest in rocketry-- and in space flight-- was the achievement of a German-- Hermann Oberth-- and an American-- Robert H. Goddard-- whose work was for practical purposes entirely independent of outside influences. Oberth

was a theoretician, and Goddard, an experimenter. Oberth had space flight in mind from the start; Goddard was interested in rocketry almost as an end in itself. Oberth never succeeded in transforming his entirely sound concepts into a functioning rocket engine; Goddard did virtually no public theorizing until he had proven the validity of his concepts by demonstration. Goddard was a proponent and practitioner of pure research; with Oberth, the object of space flight far overbore considerations of science in the abstract. Goddard published only two significant items, and one of these was a 1919 paper which evoked enough public ridicule (because it gently suggested the theoretical feasibility of hitting the moon with a payload of flash powder) to cause its author deliberately to seek obscurity for 16 years. Oberth was more interested in obtaining support for his ideas than in proving or trying them, and he was entirely willing to employ such unprofessional media as pseudo-science motion pictures in the process. Goddard was the first man to build and successfully test a liquid-fuel rocket (November 1923), and by May 1935 had succeeded in sending a gyroscope-stabilized rocket to an altitude of 7,000 feet.

(The best of the pre-Peenemunde rockets created by the German research group that eventually developed the V-2 was much heavier but attained an altitude of only 6,500 feet in about the same time period.) Oberth's efforts resulted in the formation, in July 1927, of a German Society for Space Flight which promptly set about recruiting enthusiasts, seeking publicity, and collecting funds to support experimental work. Goddard carried his objections to publicity so far as to refuse to answer letters from such groups. In 1929 Oberth reworked his 1923 book, which had started the enthusiasm in Germany, and produced as a result the most authoritative of the early treatises on experimental rocketry. Goddard made no effort to circulate the results of his work until 1936, when it was largely complete (at least he carried it little further).

Indirectly, Goddard's work led to the formation of the Aerojet Engineering Company through the Guggenheim Foundation (Jet Propulsion Laboratory of the Guggenheim Aeronautical Laboratory at

California Institute of Technology), the interest of Dr. Theodore von Karman, and Army Ordnance Department desires to use high altitude rockets to prove-out missile designs. Very much the same thing came from Oberth's efforts, which led with similar indirection to German Army sponsorship of the experimental work being conducted by the "Society for Space Flight." The Wehrmacht, of course, was not interested in space flight but was very much interested in long range artillery that did not come under the ban of the Treaty of Versailles. As it happened, that treaty became inconsequential shortly after the German Society for Space Flight did the same; Hitler's seizure of power in January 1933 coincided with the start of Army-funded rocket research, and the indifferently concealed rearmament of Germany thereafter obviated the need for any particular disguise. By that time, however, the well financed experiments had been transferred to Peenemunde, on the Baltic coast, and had produced results which encouraged the Wehrmacht to continue research toward the objective of a long range bombardment rocket. Wernher von Braun, a boyish latecomer to the Society for Space Flight, became the principal civilian manager of the Peenemunde work and converted to his way of thinking--that missiles were a step toward space flight, not an end in themselves--the unlikely figure of the military chief, Captain (later Lieutenant General) Walter Dornberger. With resources that at one time accounted for at least one third of Germany's entire aerodynamic and technological research establishment, they moved with relative rapidity from the primitive rockets of 1933 to the operationally ready V-2 bombardment missiles of 1943. Development of the V-2, or properly the A-4, began during the winter of 1938-1939 as the climax of five years of applied research. The first successful operational prototype, and the third test vehicle in the series, completed a field trial on 2 October 1942; more than 100 production versions were tested in Poland in the early months of 1943. The first combat firing at London came on 8 September 1944, and by March of the following year more than 1,300 V-2's had followed the first to England.



Unfortunately, from the standpoint of the scientist and the space flight enthusiast, concentration of attention on bombardment missiles neatly eliminated serious work on space research. At least four people (Tsiolkovski, Oberth, Goddard, and Dr. Walter Hohmann of Hamburg) had worked out perfectly valid data on exhaust velocities, mass ratios, and trajectories before 1930. The decade of the 30's was spent in carrying rocket technology to the point of practical application, and during the first half of the 40's, rocket technology was applied to the art of war. There were some few exceptions, concentrated largely in Germany, where the only propulsion systems with sufficiently high thrust to promise eventual space applications were being perfected. Walter Dornberger recalled several years after the fact that "our aim from the beginning was to reach infinite space, and for this we needed speeds hitherto undreamed of. Range and velocity were the great landmarks that guided our thoughts and actions." In another context he remarked, "With our big rocket motors and step rockets we could build space ships which would circle the earth like moons. Space stations . . . could be put into orbit around the earth. An expedition to the moon was a popular topic too."

## Independent Study Project by David Linke

### Entry Rankings & Validation

In addition to coding each of the entries for a number of variables, an opportunity arose to choose the top entries based on technical feasibility. The New England chapter of the American Institute of Aeronautics and Astronautics (AIAA) had decided to offer an award to the top entry as well as honor other top entries based on technical feasibility. In order to find the top entries, a group of students working on an interactive qualifying project at WPI as well as myself went through each of the entries and picked our favorites. We collaborated in discussing our top choices until we decided on the ten best entries. On December 8, 2010 we co-presented these ten entries to members of the AIAA, highlighting the positive and negative aspects of each. The attendees ranked each of the entries in terms of technical feasibility from 1 to 5, 1 being the least and 5 being the most feasible. At the end of the presentation the attendees were asked to choose their top three entries. I also presented some of the findings of my research based on the frequency distributions described in the discussion of results section of this report.

On December 9, 2010 we presented the same top entries to student members of the AIAA, members of the Student Pugwash organization, and other students interested on the WPI campus. They were asked to rank each of the entries in the same manner as the AIAA presentation and also were asked to choose their top three entries. Once we had the rankings from both presentations they were totaled in order to rank the top entries.

In addition to having the top entries by ranking from the presentation attendees, the top entries we chose were sent to three experts on the moon. These experts ranked them in order of their favorites, which produced more data for use in choosing the top entries. Comparing the expert's rankings and the rankings from the presentation attendees, the top entry as well as some honorable mentions became clear.

Of more notable interest for this study than the selection of the top entries is the value of the technical feasibility rankings from the attendees of the two presentations. These rankings can be compared against the rankings of the group I collaborated with as well as my rankings for the likelihood that the lunar base entries would work. By analyzing the relationships between the rankings of the attendees and the group I collaborated with we can observe how correlated the knowledgeable attendees rankings were against our own. Of more importance is analyzing the relationships between

the rankings of the attendees and my rankings for the likelihood that the lunar base entries would work. If they were highly correlated it would suggest my rankings for all the entries in the work category are the same as those that any knowledgeable person would give, and thus validate my rankings. The results from analyzing these relationships can be seen in the discussion of results section.

## Discussion of Results

### Frequency Distributions

#### Categories

Each of the analyzed competition entries was assigned a category that best described them. A category distribution chart can be seen in **Error! Reference source not found.** of the appendix. Habitat concept was the most populous category with about 1/3 of the entries, 30 out of 89, falling under it. Lunar base, the category for entries that went beyond simply creating a habitat to form a complete lunar base, encompassed 16 of the 89 entries. The category for entries that focused on a single use of technology on the moon, technological concept, best described 12 out of the 89 entries. Agricultural concept category entries were the least common, with only 6 entries out of 89 focusing on agriculture on the moon. Entries that focused primarily on the commercial uses of the moon, commercial concepts, comprised 10 of the 89 entries. Artistic depiction, a category for entries that did not fit into the others, contained about 1/6 of the entries, or 15 out of 89. The categories are fairly evenly distributed, with half depicting habitats for humans (lunar bases and habitat concepts) and half focusing on other aspects of potential uses for the moon.

#### Standard Variables

Each of the analyzed competition entries was coded for a number of variables. The frequency distributions for these can be seen **Error! Reference source not found.** of the appendix with additional frequency distributions for lunar base category entries only in **Error! Reference source not found.**. The distributions are broken up by category in order to explore them further and compare them to those of variables in other categories. Frequency distribution bar graphs for all categories and just lunar base category entries can be seen in **Error! Reference source not found.** and **Error! Reference source not found.**, respectively. In addition to the frequency distributions, descriptive statistics are provided in **Error! Reference source not found.**.

In the agricultural concept category, the quality of life was average, slightly leaning towards the higher side. 1/3 of these entries made efforts to sustainably use lunar resources while none of the entries had any planned exports back to Earth. 2/3 of the entries would not work at all, with 1/6 having the potential to work and 1/6 likely to work. Only 1/6 of the entries made heavy use of in situ resources, with the rest using none at all. None of the entries were specific about their location on the moon.

In the artistic depiction category, the quality of life is average but leaning towards the lower side. None of the entries made efforts to sustainably use lunar resources. ~13% had planned exports of

resources back to earth. About 1/4 of the entries would likely work, with 1/3 possibly working. Only ~7% of the entries used some in situ resources in the construction of the design, with the rest using neither full use of local resources or none at all. ~7% of the entries specified a general location while the rest specified none.

In the commercial concept category, half of the entries had a high quality of life, with 1/3 being average and 1/5 being low. 20% of the entries made sustainable use of lunar resources and 30% had planned exports of resources back to earth. 20% of the entries were in between possibly working and likely working with another 10% possibly working. 30% of the entries made some efforts to use in situ resources however 70% made none at all. 10% were highly specific of location, with another 10% specifying a general location and the rest not specifying a location at all.

In the habitat concept category, quality of life was very high with nearly 2/3 being high, 30% being average, and ~7% being low. 1/6 of the entries made efforts to sustainably use lunar resources while only ~3% had planned exports back to earth. ~1/3 of the entries would possibly work on the moon while the rest wouldn't work at all. ~3% of the entries made heavy use of in situ resources in the construction of the design, with 1/6 using some local resources and the rest using none. ~7% were highly specific in their location with ~3% having a general location and 90% having no specific location.

In the lunar base concept category, quality of life was high, with 50% of entries being high and 50% being average. 1/8 of the entries made sustainable use of lunar resources as well as 1/8 having planned exports of resources back to earth. In terms of if the entries would work this category performed the highest. ~19% would probably work, ~38% were in between possibly working and probably working, and ~31% would possibly work. 1/6 of the entries made heavy use of in situ resources in the construction of the base, with ~38% using some local resources, ~6% being in between none and some use of local resources, and the rest using none at all. This category had the highest specificity of location with ~38% being highly specific, 12.5% having a general location and 50% having no specified location. In addition to these variables used for all category entries, lunar base category entries were coded for 5 additional variables. In terms of how well the bases satisfied their energy requirements, ~31% had enough energy for the base, ~19% specified an energy source but that source would not likely satisfy the energy requirements of the base, and ~50% specified no energy source at all. 50% of the entries had planned a feasible method food production, with ~31% having specified a source of food production but not placed it as a priority and ~19% had no apparent food production. Only ~19% of entries had radiation protection that would likely meet all radiation protection needs, with 75% not

having sufficient protection and ~13% having little protection at all. In terms of if the bases had a clear purpose for being on the moon, ~19% had a specific purpose, ~69% were general-purpose scientific facilities, and ~13% had no apparent purpose other than to support human life. Only ~13% of the bases had multiple air locks for effectively getting in and out of the bases, with 75% having a single air lock and ~13% having none.

In the technological concept category, quality of life was quite low with only ~8% of entries having a high quality of life, 1/3 being average, and ~58% being low. Only ~8% of entries made sustainable use of lunar resources as well as ~8% having any planned exports of resources back to earth. None of the entries were likely to work, with 1/3 having the possibility of working and the rest not working at all. 1/3 of entries made some efforts at using in situ resources in the construction of the design with 2/3 using none at all. Location was quite non-specific with ~8% specifying a general location and the rest no location at all.

When observing all of the entries, quality of life was fairly high with ~44% of entries being high, ~37% being average and ~19% being low. ~13% of entries made efforts to sustainably use lunar resources while only ~10% had any planned exports of resources back to earth. The likelihood that entries would work was rather low, with ~9% probably working, ~9% being in between possibly working and probably working, ~30% possibly working and nearly ~52% not working at all. In situ resource utilization was also low, with only ~4% making heavy use of local materials in the construction of the design, ~21% making some use of local materials, 1% making in between none and some use of local materials, and ~73% making no use of local materials at all. Location was also fairly non-specific, with ~10% being highly specific, ~7% specifying a general location and ~83% specifying no location at all.

### Compound Variables

Due to the nature of the compound variables not being evenly rounded or grouped, frequency distributions were not useful in examining them. However, descriptive statistics are useful in describing their characteristics. These can be seen in **Error! Reference source not found.** of the appendix. The compound variable “value” was created from variables sustainability, in situ resource utilization, and planned exports of resources as these variables can indicate the perceived value of the moon. The minimum score for “value” is 1 while the maximum is 2.33. The average is 1.182, which suggest a very low perceived value of the moon for its resources. The compound variable “knowledge” was created for just the lunar base category entries and consists of would the base work, location specificity, meeting energy requirements, food and agriculture efforts, radiation protection, and the use of air locks. The

scores of these values are all indicative of how well thought out the base design and how knowledgeable the designer was on the moon. The minimum score for “knowledge” is a 1.5 while the maximum score is a 3.0. The average is 2.063, which suggests a slightly above average knowledge of the moon considering that the base variables used to compute knowledge ranged from 1 to 3.

### Relationships

In the research methodology section of this report I theorized potential relationships between variables and their outcomes. These relationships were explored by computing cross-tabulations with Gamma and Chi-Square values since this is ordinal data using IBM SPSS Statistics 19. Spearman correlation values were also computed for relationships involving compound variables. However, they offered no new information or insights that the gamma variable hadn’t already provided and were omitted. Attempts at performing regression analyses to study the dependence of variables on others failed because SPSS does not allow this analysis with ordinal data. The cutoff value for the significance of the correlation values was set at .1 or 10%.

### Standard Variables

The first relationship theorized was between the quality of life and the likelihood the entries would work. I believed that the more likely the entry would work, the lower the quality of life would be. The table of results for this can be seen in **Error! Reference source not found..** For lunar base category entries my theory was almost false, as it was barely significant for the standard work values and not significant when rounding the work values to 1, 2, or 3. My prediction was proved correct for entries not in either lunar base or habitat concept categories, with significance values of .45 and a gamma value of -.388. The same held true for when work values were rounded, with a significance of .44 and gamma value of -.396. In the case of when work values were rounded, the chi-square value was also significant with a significance of .07 and a value of 8.671. When observing habitat concepts and lunar bases together or all the entries combined there were no significant relationships.

The second relationship theorized was between the quality of life and the in situ resource utilization in the construction of the bases. I believed that the more in situ resource utilization, the lower the quality of life would be. The table of results for this can be seen in **Error! Reference source not found..** For lunar base category entries I was proved wrong with a significance value of .015 and a gamma value of .739. When observing in situ resource utilization as either some or none, it was less significant with a significance value of .102 and gamma value of .667. For categories other than lunar bases or habitat concepts, there was a negative relationship a significance of .056 and a gamma value of

-.481, holding true for my theory. The same holds true when in situ resource utilization was reduced to either some or none, with a significance of .06 and a gamma value of -.469. In this case the chi-square value was also slightly significant, with a significance of .105 and value of 4.504. When observing habitat concepts and lunar bases together or all the entries combined there were no significant relationships.

The third relationship theorized was between the quality of life and the specificity of location. I was not sure what to expect of this analyses and did not predict the potential outcome. The table of results for this can be seen in **Error! Reference source not found.**. When looking at all the entries, there was a positive relationship with a significance value of .01 and a gamma value of .564. The chi-square value was also significant, with a significance of .081 and value of 8.296. This shows that in general, the higher the quality of life the more likely the entry was specific in its choice of location. Breaking down the analysis into any group of categories resulted in no significant relationships.

The fourth relationship theorized was for lunar base category entries only between the quality of life and the energy requirements of the base. I predicted that the higher the energy requirements of the base was satisfied, the more likely that the quality of life would be high. The table of results for this can be seen in **Error! Reference source not found.**. No significant relationships resulted from this analysis.

The fifth relationship theorized was for lunar base category entries only between the quality of life and the focus on providing food for the base. I believed that the more effort put into having an adequate food supply would result in a higher quality of life depicted. The table of results for this can be seen in **Error! Reference source not found.**. This proved to be highly significant in my favor, with a significance of .003 and gamma value of .826. The chi-square value was also significant, with a significance of .074 and a value of 5.2.

The sixth relationship theorized was for lunar base category entries only between the quality of life and specificity of purpose. I believed the higher the specificity of purpose the lower the quality of life would be. The table of results for this can be seen in **Error! Reference source not found.**. No significant relationships resulted from this analysis.

The seventh relationship theorized was between the likelihood that the entries would work and the in situ resource utilization in the construction of the entries. I believed that for lunar base category entries, the greater the use of local materials the more likely it would work. The table of results for this can be seen in **Error! Reference source not found.**. There was no significant relationship when looking at



just lunar base category entries, however the gamma value is significant for habitat concepts combined with lunar bases and the chi-square value is significant for entries other than lunar bases and habitats. There is sufficient unexplained variance here to warrant further studies if time permitted.

The eighth relationship theorized was between the likelihood that the entries would work and the specificity of location. I believed that for lunar base category entries, the more specific the location the more likely it would work. The table of results for this can be seen in **Error! Reference source not found.** This proved to be slightly significant with the chi-square value, with a significance of .097 and a value of 10.733. However, this was highly significant when looking at both the habitat concepts and lunar bases combined. In this case, the gamma value had a significance of .039 and a value of .493 where the chi-square value had a significance of .001 and a value of 22.919. When looking at categories other than lunar bases or habitat concepts, a negative relationship was seen with a significance of .03 and a gamma value of -1.

The ninth relationship theorized was for lunar base category entries only between the likelihood that the entries would work and the specificity of purpose. I believed that the more specific the purpose the more likely it would work. The table of results for this can be seen in **Error! Reference source not found.** No significant relationships resulted from this analysis.

### Compound Variables

I theorized that two compound variables could be created from the variables I had coded for, one for the perceived value of the moon and one for the knowledge of the moon. These can be used to explore relationships that could not be explored properly using the standard base variables coded for.

The tenth relationship theorized was between the quality of life depicted and the perceived value of the moon. I believed the higher the quality of life the higher the perceived value of the moon. The table of results for this can be seen in **Error! Reference source not found.** This proved to be significant for lunar base category entries only, with a significance of .037 and a gamma value of .66. When using the value compound variable rounded to either 1, 2, or 3 the results were similar, with a significance of .018 and gamma value of .733 for lunar base category entries. While this proved my theory, it did not apply to any of the other groups.

The eleventh relationship theorized was for lunar base category entries only between the quality of life depicted and the knowledge of the entries creators of the moon. I believed the higher the quality of life the less knowledgeable the entries designer of the moon would be. The table of results for

this can be seen in **Error! Reference source not found.** This proved to be significant with a significance of .068 and gamma value of .492. This disproved my theory completely, demonstrating that the higher the quality of life depicted the higher the knowledge of the moon.

The twelfth relationship theorized was between the likelihood that the entries would work on the moon and the perceived value of the moon. I believed the more likely an entry would work the higher the perceived value of the moon would be. The table of results for this can be seen in **Error! Reference source not found.** This has some strange results, as it is shown to be significant for habitats and lunar bases with the gamma value and significant for other categories and all categories with the chi-square value when value is rounded to 1, 2, or 3. When value is in its continuous form, it is significant for habitats and lunar bases with both the gamma and chi-square values. The gamma value is .362 with a significance of .095 and the chi-square value is 21.643 with a significance of .042. This is also significant for other categories and all categories with the chi-square value. My theory seemed to hold true in this case, however there is sufficient unexplained variance here to warrant further studies if time permitted.

The thirteenth relationship theorized was for lunar base category entries only between the likelihood that the entries would work on the moon and the knowledge of the entries creators of the moon. I believed the more likely an entry would work on the moon the more knowledgeable the entries creators would be on the moon. The table of results for this can be seen in **Error! Reference source not found.** No significant relationships resulted from this analysis.

The fourteenth relationship theorized was between the specificity of location and the perceived value of the moon. I was not sure what to expect of this analyses and did not predict the potential outcome. The table of results for this can be seen in **Error! Reference source not found.** No significant relationships were uncovered when looking at the gamma values, however the chi-square values were significant for habitat concepts and lunar bases combined as well as looking at all categories. This suggests a non-linear relationship between the two that is not approximated by the gamma variable well. There is sufficient unexplained variance here to warrant further studies if time permitted.

The fifteenth relationship theorized was for lunar base category entries only between the specificity of location and the knowledge of the entries creators of the moon. I believed the more specific the location the more knowledgeable the entries creators would be on the moon. The table of results for this can be seen in **Error! Reference source not found.** This was a bit tricky to explore as the

knowledge compound variable contains location as a factor. This was highly significant with location included in the knowledge variable, with a gamma value of .583 and a significance of .006. However, after removing location from the knowledgeable variable there was no relationship. It is safe to say there is no strong relationship between these entries caused by a variable other than location.

The sixteenth relationship theorized was for lunar base category entries only between the perceived value of the moon and the knowledge of the entries creators of the moon. I believed the higher the perceived value of the moon the more knowledgeable the entries creators would be on the moon. The table of results for this can be seen in **Error! Reference source not found.** No significant relationships resulted from this analysis.

### Technical Feasibility

After presenting the top 10 entries to members of the New England chapter of the AIAA and members of Student Pugwash organization, technical feasibility rankings for each entry were collected from each of the attendees. This presented an opportunity to cross-validate my rankings for the work variable as well as the technical feasibility rankings given by myself and a group of students conducting an interactive qualifying project at WPI. The table of results for this can be seen in **Error! Reference source not found.** When looking at how the collective technical feasibility rankings of myself and the group of students I worked with compared to my rankings for the work variable, it is clear there is a highly significant relationship. This resulted in a gamma value of .813 and a significance of 0. This shows that my rankings for the work variable were highly correlated to technical feasibility, allowing the comparison to be made between the technical feasibility rankings of the presentation attendees and my work variable. These also proved to be significant, with a gamma value of .548 and a significance of .077. This demonstrates the likelihood that the attendees would have ranked the entries very similar as I did for the work variable. When looking at the relationship between the technical feasibility rankings of myself and the group of students I worked with and the presentation attendees, there is a highly significant relationship. This had a gamma value of .744 and a significance of 0. This further reinforces the relationships between the work variable and technical feasibility rankings from both parties.

### Moon Capital Competition 2010

The Moon Capital Competition set out to find the best of participant's lunar base designs. When the competition was announced, two prizes were to be given; one for "Let's Get Serious" entries that followed the rules for creating a lunar base and one for "Let's Have Fun" entries that could depict anything from lunar foods to fashions and sports to technologies. Due to lack of funding, the

competition only had enough money for one prize and decided to combine the two categories into one. While this may have been the best option given the situation, the criteria for selecting the winner and finalists should have been equally weighted between both types of entries. Instead, of the 4 finalists, only 1 was a serious lunar base entry.

After hearing the jurors of the competition speak at the Moon Ball 2010 event, it became apparent that they did not see the moon as a desirable place. They seemed to have a harsh perspective on the moon despite it being a lunar competition. The two finalist entries that depicted habitats are completely modular designs that are not tailored for specific use on the moon; they can be used on other planets such as Mars. While the judges may not have been entirely on the Mars side of the moon vs. Mars debate, they certainly weren't enthusiastic about the moon. The other finalist and the winner were innovative designs that, while rendered beautifully, were highly impractical. The merging of the two prizes and the choice of finalists was a disappointment to those who had worked hard making the most feasible and technologically elegant lunar bases possible. Had the perceptions of the jurors been more positive of the moon, it is likely they would have expressed more interest in the entries that designed bases truly meant for the moon.